

L-765

NATIONAL ADVISORY COMMITTEE FOR AERONAUTICS

# WARTIME REPORT

ORIGINALLY ISSUED  
November 1944 as  
Advance Confidential Report L4J25

CASCADE INVESTIGATION OF BUCKETS FOR A  
MODERN AIRCRAFT TURBOSUPERCHARGER

By Arthur Kantrowitz and John R. Erwin

Langley Memorial Aeronautical Laboratory  
Langley Field, Va.



WASHINGTON

NACA WARTIME REPORTS are reprints of papers originally issued to provide rapid distribution of advance research results to an authorized group requiring them for the war effort. They were previously held under a security status but are now unclassified. Some of these reports were not technically edited. All have been reproduced without change in order to expedite general distribution.

NATIONAL ADVISORY COMMITTEE FOR AERONAUTICS

---

ADVANCE CONFIDENTIAL REPORT

---

CASCADE INVESTIGATION OF BUCKETS FOR A  
MODERN AIRCRAFT TURBOSUPERCHARGER

By Arthur Kantrowitz and John R. Erwin

SUMMARY

A cascade investigation in two-dimensional flow was carried out in the Langley 5-inch cascade tunnel and the Langley 1-inch turbine-element testing apparatus to obtain a satisfactory bucket design for use in a modern aircraft turbosupercharger. This investigation included tests of the original bucket sections of conventional design and tests of bucket sections designed by the NACA.

Velocity-distribution and turning-angle data were obtained in the Langley 5-inch cascade tunnel for the operating range of velocity ratio and are presented in graphical form for all of the sections tested with the exception of the original bucket tip section, over which the flow separated to such an extent that turning-angle data could not be obtained. Schlieren photographs of high-speed air flow about all the buckets tested are presented with measurements of the maximum Mach number attainable ahead of the cascade.

The NACA turbine bucket sections showed promise of significant improvements. Rotating-machine tests are needed to make the improvements measurable directly in terms of lowered back pressure on the engine or increased turbosupercharger performance.

INTRODUCTION

One phase of research undertaken by the NACA in an attempt to improve supercharger performance has been the cascade investigation of the original turbine buckets of a modern aircraft turbosupercharger, the development of buckets by the NACA, and the cascade investigation of the NACA buckets.

The investigation comprised tests of models in two-dimensional flow at low speeds in the Langley 5-inch cascade tunnel and at high speeds in the Langley 1-inch turbine-element testing apparatus, referred to as the "1-inch jet." The tests in the Langley 5-inch cascade tunnel consisted of a study of the static pressures on the bucket surfaces, the turning angles, and the separated regions. The tests in the 1-inch jet consisted of flow and static-pressure measurements ahead of the buckets and schlieren photographs of the flow.

#### APPARATUS AND TESTING METHODS

The low-speed tests were made in the Langley 5-inch cascade tunnel, described in reference 1 and schematically diagrammed in figure 1. In the original turbosupercharger, the sections tested are located at the following diameters: root section, 11.03 inches; pitch section, 12.28 inches (pitch diam.); tip section, 13.53 inches. The radial width of the passage is 1.500 inches. The models of the bucket sections had the following chords (measured perpendicular to the stagger line):

Type	Root chord (in.)	Pitch chord (in.)	Tip chord (in.)
Original	9.01	6.42	4.31
NACA	9.00	6.64	4.83

In each case, the spacing of the bucket section was 5 inches measured parallel to the stagger line, and all models had a span of 5 inches. The cascade consisted of five blades set relative to the stagger line as shown in figure 1. A study was made of the pressure distribution and the air flow about the central blade, which was equipped with static-pressure orifices. The flow was examined with a tuft to locate regions of separated flow. When separated regions were found, the extent of separation was determined by explorations with an impact tube. The direction of the flow before entering was assumed parallel to the tunnel axis and after leaving was determined with a yaw head. The airspeed in these tests,

which was measured by static-pressure orifices 1 chord ahead of the models, was about 110 feet per second.

The high-speed tests were made in the Langley 1-inch turbine-element testing apparatus, which is schematically diagrammed in figure 2. The models of the bucket sections had the following chords (measured perpendicular to the stagger line):

Type	Root chord (in.)	Pitch chord (in.)	Tip chord (in.)
Original	2.34	1.75	1.10
NACA	2.43	1.73	1.27

The spacing of all of the sections (measured parallel to the stagger line) was 1.30 inches, except that the NACA root section and the original pitch section were built to a 1.35-inch spacing. All models had a span of 1 inch. Orifices in the guide blocks 1 chord ahead of the four-blade cascade were used to measure the static pressure and hence the Mach number at the entrance to the buckets.

## RESULTS AND DISCUSSION

Two-dimensional tests at best cannot completely reproduce operating conditions that exist in turbosuperchargers. The tests in the 1-inch jet were conducted at Mach numbers from zero through the choking Mach number, the range over which the turbine operates. The Reynolds numbers for the tests in the 1-inch jet and the Langley 5-inch cascade tunnel were considerably larger than the turbine Reynolds number. Three-dimensional flows and rotational effects were not reproduced. For these reasons, rotating-machine tests are the only means of quantitatively evaluating bucket designs.

Conditions relative to the rotating buckets were simulated in the tests. The relation between the angle at which air enters the cascade and the corresponding velocity ratio in the turbine is

$$\xi = \frac{\cos(\kappa + \beta)}{\cos \beta}$$

where

$\xi$  ratio of velocity of turbine to theoretical velocity of gas leaving nozzles

$\kappa$  angle between tangential direction and direction at which gas leaves turbine nozzles, relative to nozzles; for original turbosupercharger,

$$\kappa = 20\frac{1}{2}^{\circ}$$

$\beta$  stagger angle, that is, angle between incoming air and a perpendicular to cascade, relative to cascade (fig. 1)

It was reported to NACA that the design pitch velocity ratio  $\xi_p$  was 0.450, which corresponds to a stagger angle  $\beta$  of  $54^{\circ}$ . By the geometry of the turbine, if a uniform velocity and angle at the nozzle exit are assumed, the design root velocity ratio  $\xi_r$  is then 0.404, which corresponds to a stagger angle  $\beta$  of  $56.5^{\circ}$ , and the design tip velocity ratio  $\xi_t$  is 0.496, which corresponds to a stagger angle  $\beta$  of  $52^{\circ}$ . The low-speed tests were therefore run at stagger angles that would simulate the velocity ratios over a range centered about the design conditions.

The buckets developed by the NACA were designed to have the same section areas as the original sections, on the assumption that the rotation stresses in the NACA bucket would be no higher than the stresses in the original bucket. The NACA sections were designed to turn the flow the same amount as corresponding original sections. For all flow velocities, an attempt is made in the original designs to maintain the flow leaving the buckets parallel to the trailing-edge direction by means of guidance, that is, by having the passage walls parallel to each other at the trailing edge.

In the experiments in the 1-inch jet, an attempt was made to evaluate the relative merits of the original and NACA sections by measuring the Mach number ahead of the blades at which choking occurred in the blade passages. The choking Mach number is defined as the highest Mach number attainable ahead of the blades. It is evident that, other things being equal, a higher choking Mach number for the same turning angle indicates a more efficient passage.

Schlieren photographs were taken of high-speed flow about each bucket section set at the design velocity ratio for a series of pressure ratios. These photographs indicate separated regions quite clearly and show good correlation with the results of the tuft and impact-tube explorations in the Langley 5-inch cascade tunnel, particularly in the case of the original tip section. Local high-velocity regions, as measured in the low-speed cascade tests, lower the choking Mach number. This effect is demonstrated by comparison of the data presented on velocity distribution and choking Mach number.

#### Root Sections

The NACA root section is similar to the original root section shown in figure 3 except that the convex surface has an arc of larger radius preceding the straight trailing edge (fig. 4). A comparison of the velocity distributions of the original root section (fig. 5) and the NACA root section (fig. 6) indicates that both sections are satisfactory. The NACA blade has a more uniform flow pattern; figure 6 shows no peaks and the high-velocity region is maintained well back along the convex surface. Both root sections exhibited thickened boundary layers on their convex surfaces, but the flow did not separate over either section. The turning angle of the NACA section varies only slightly from that of the original section.

In the 1-inch jet, the maximum Mach number of the flow entering the cascade was equal to 0.67 for both cascades. The two sections thus operate much the same at high speeds. The schlieren photographs of the original root section (fig. 7) and the NACA root section (fig. 8) indicate that the flow over both models simultaneously becomes supersonic over a large part of the chord.

#### Pitch Sections

Guidance is incorporated in the original pitch section (fig. 9) but not in the NACA pitch section (fig. 10). In the design of the NACA section, an attempt was made to prevent separation and to allow operation at high Mach numbers by using increased radii in the convex surfaces.

The velocity distribution over the original pitch section (fig. 11) shows relatively high velocities over the leading half of the chord, which suggests that sonic velocities would be reached in the flow over this bucket before the entrance Mach number becomes high. Figure 11 also indicates a rapid pressure recovery between 50 and 60 percent chord. The velocity distribution over the NACA pitch section (fig. 12) shows lower local velocities with a less steep pressure recovery. Both buckets turn the air similarly and exhibit thickened boundary layers with little separation.

Schlieren photographs for the tests in the 1-inch jet give evidence that the separation and turbulence in the flow through the original pitch section (fig. 13) has been reduced in the NACA design (fig. 14). For the original blade, choking occurred at an entrance Mach number of 0.58. The NACA bucket did not choke until an entrance Mach number of 0.72 was reached. The NACA pitch bucket section is considered to be a definite improvement.

#### Tip Sections

As may be seen from figure 15, the original tip section does not represent modern aerodynamic design. The flow over this section was found by impact-tube survey to be badly separated. The velocity distribution was typical of separated flow. Because of the limited area allowed for the tip section to comply with the stress requirements, the NACA tip section (fig. 16) could not be designed to eliminate completely the flow separation found in the original tip section (fig. 17). Hollow buckets might, however, make such design possible. The compromise section selected (fig. 16) does prevent separation over the leading 60 percent of the convex surface and does keep to a minimum separation on the concave surface. This section has no guidance. The velocity distribution (fig. 18) is fairly good, although a tendency to peak at 60 percent chord is evident for velocity ratios greater than 0.57. The flow turning angles approximate those intended for the original tip section.

The schlieren photographs of the original tip section (fig. 19) show separation occurring in the same manner as was found in the low-speed tests (fig. 17). The photographs of the NACA tip section (fig. 20) indicate

that the separation has been greatly diminished over the convex surface and has become invisible over the concave surface. The entrance Mach number at which choking occurred was 0.48 in the original design but was increased to 0.63 in the NACA design, an important improvement.

#### CONCLUSIONS

A cascade investigation in two-dimensional flow of the original buckets and of buckets designed by the NACA for a modern aircraft turbosupercharger has been carried out at LMAL. The bucket sections were tested at low speeds in the Langley 5-inch cascade tunnel and at high speeds in the Langley 1-inch turbine-element testing apparatus. The results of this investigation indicated the following conclusions:

1. Both the original and NACA root bucket sections were satisfactory.
2. The NACA pitch section was a definite improvement over the original pitch section.
3. The NACA tip section was satisfactory, whereas the original tip section had badly separated flow.
4. Rotating-machine tests are needed to make the improvements measurable directly in terms of lowered back pressures on the engine or increased turbosupercharger performance.

Langley Memorial Aeronautical Laboratory  
National Advisory Committee for Aeronautics  
Langley Field, Va.

#### REFERENCE

1. Kantrowitz, Arthur, and Daum, Fred L.: Preliminary Experimental Investigation of Airfoils in Cascade. NACA CB, July 1942.

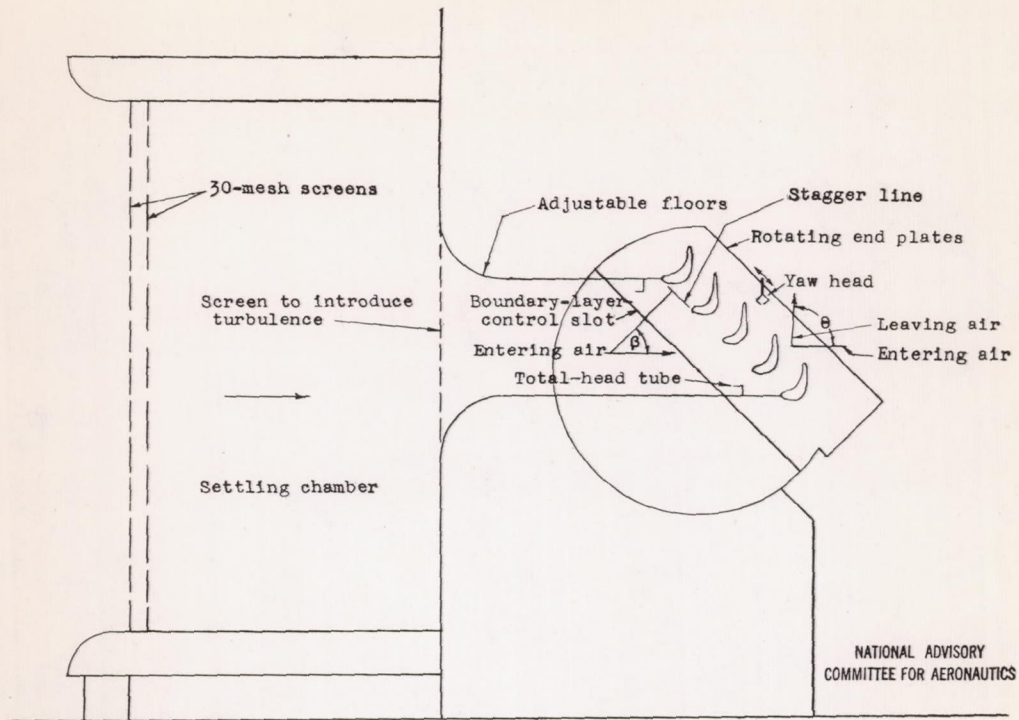

Figure 1.- Langley 5-inch cascade tunnel.

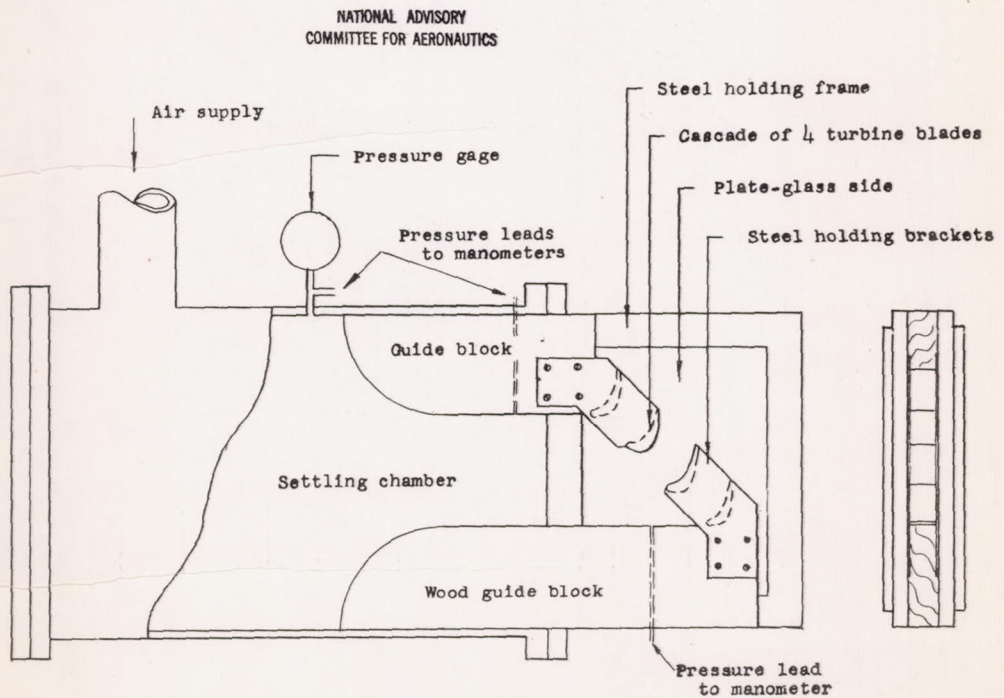
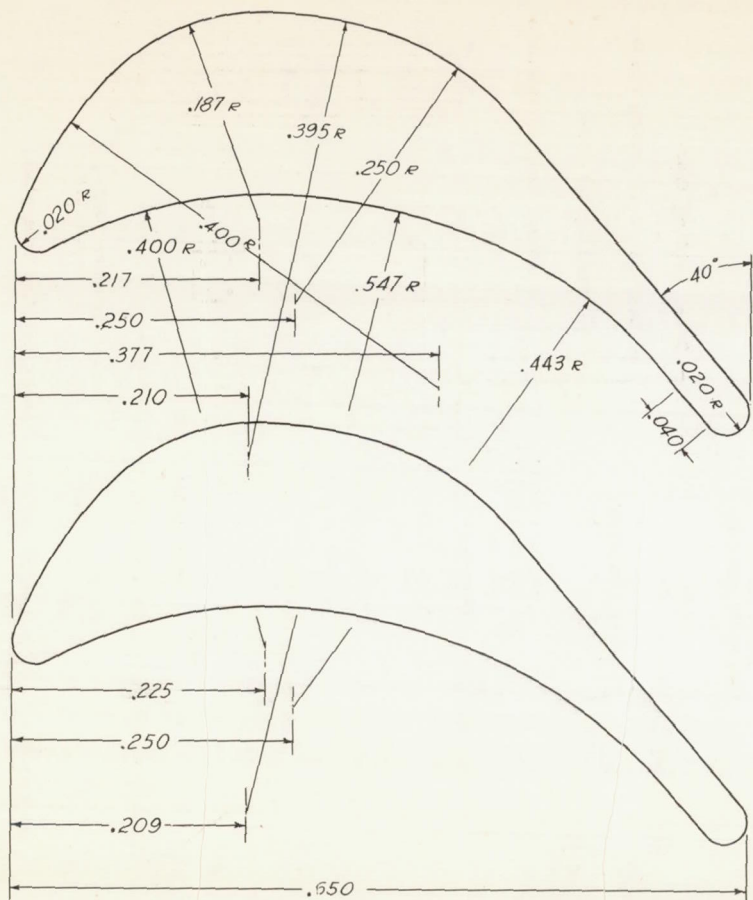
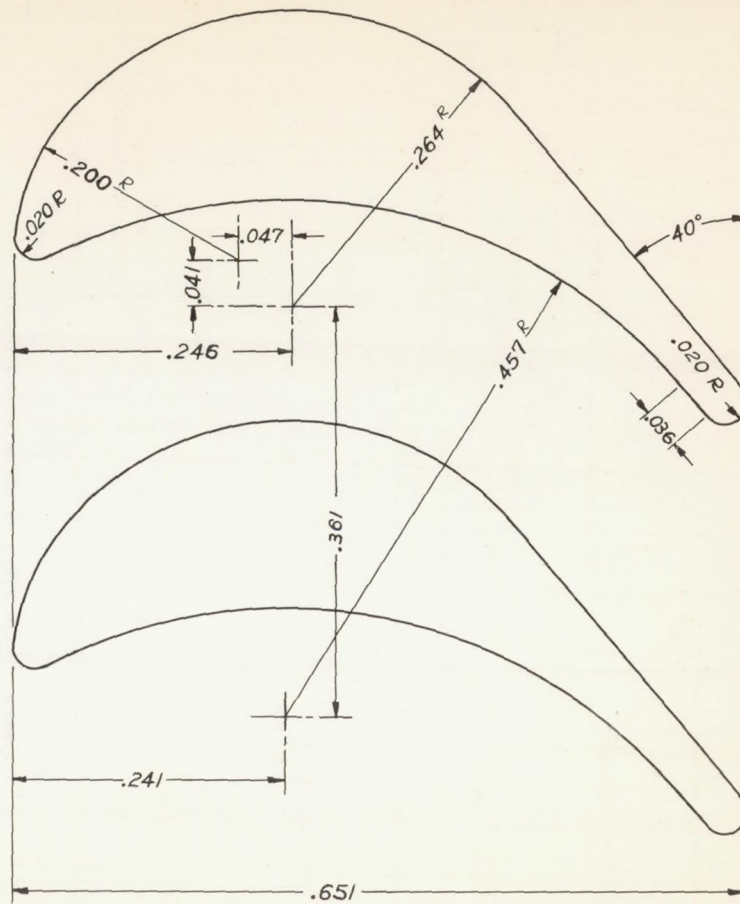

Figure 2.- Langley 1-inch turbine-element testing apparatus.



NATIONAL ADVISORY  
COMMITTEE FOR AERONAUTICS

Figure 3.- Original bucket root section designed for a modern aircraft turbosupercharger. All dimensions are in inches.



NATIONAL ADVISORY  
COMMITTEE FOR AERONAUTICS

Figure 4.- Bucket root section designed by NACA. All dimensions are in inches.

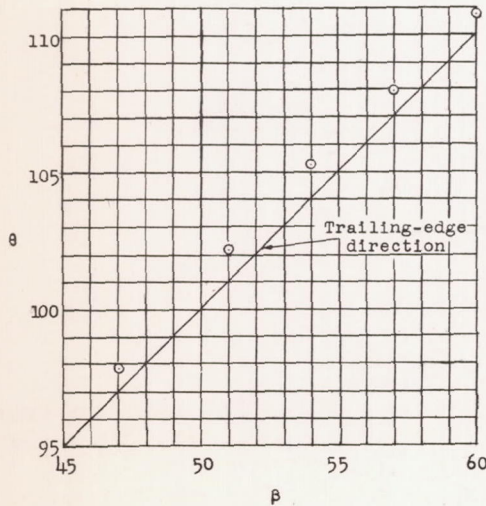
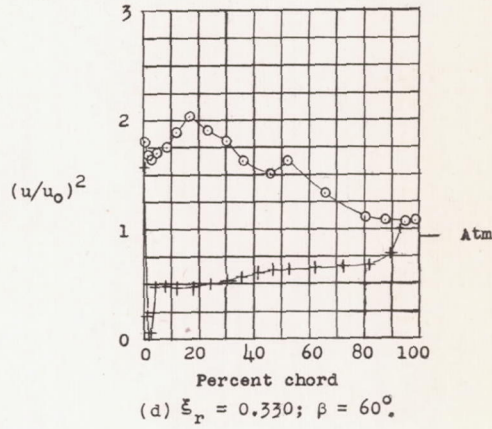
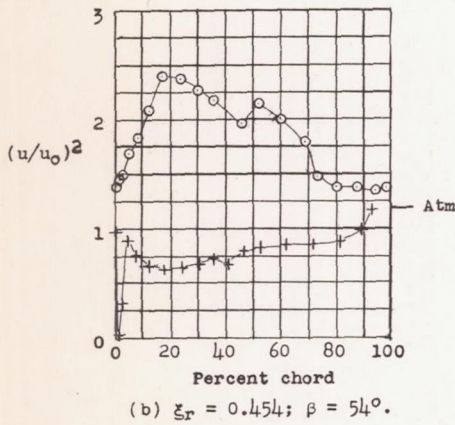
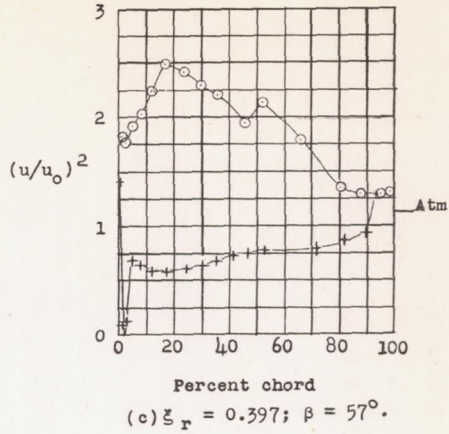
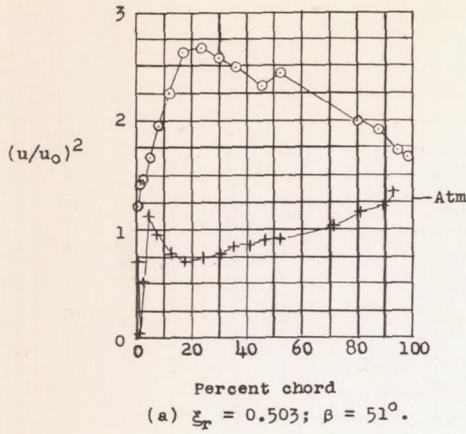

NATIONAL ADVISORY  
COMMITTEE FOR AERONAUTICS

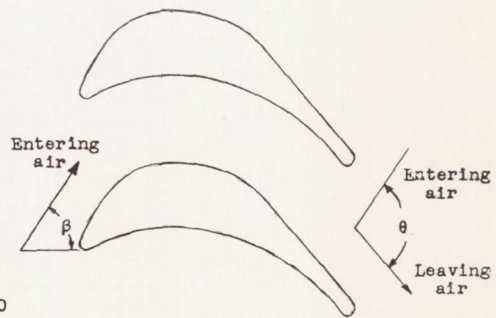
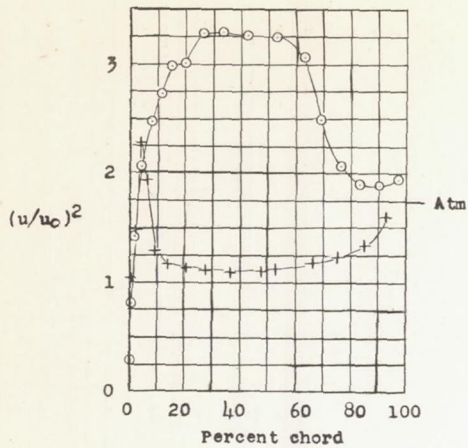
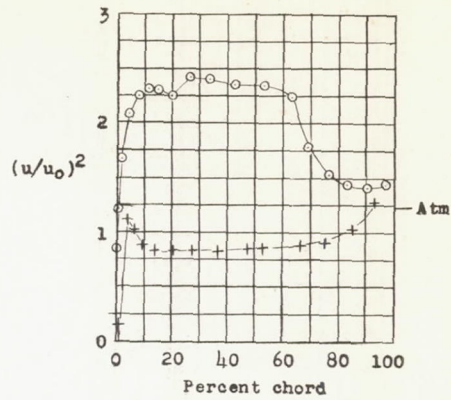

Figure 5.- Velocity distribution and turning angle of original root section. Atm indicates velocity that would result if air were expanded to atmospheric pressure;  $u$ , local air velocity;  $u_0$ , air velocity ahead of cascade.



(a)  $\xi_r = 0.582$ ;  $\beta = 45^\circ$ .



(c)  $\xi_r = 0.470$ ;  $\beta = 53^\circ$ .

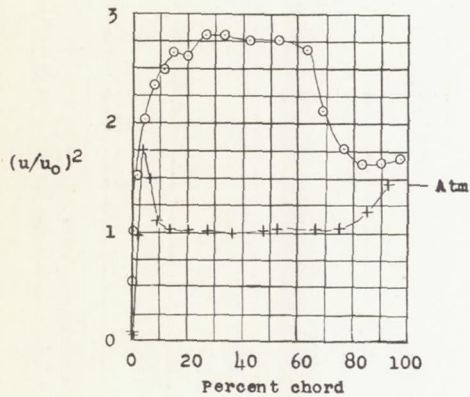

(b)  $\xi_r = 0.535$ ;  $\beta = 49^\circ$ .

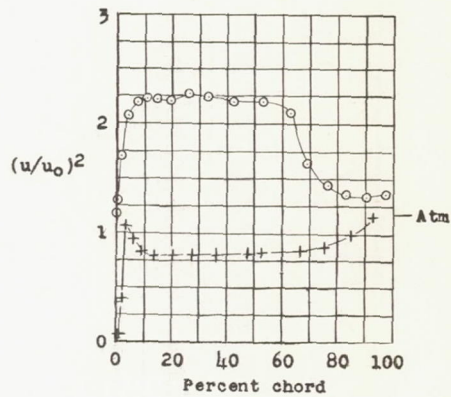

(d)  $\xi_r = 0.397$ ;  $\beta = 57^\circ$ .

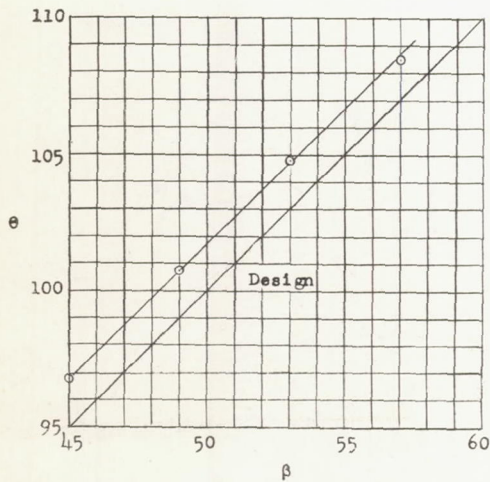

NATIONAL ADVISORY  
COMMITTEE FOR AERONAUTICS

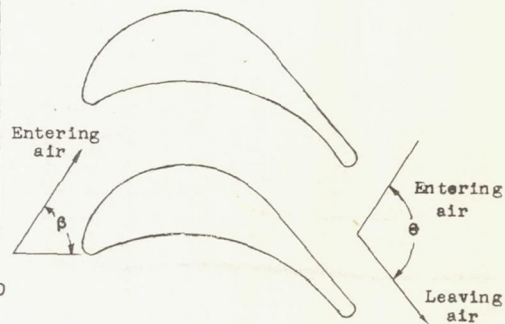

Figure 6.- Velocity distribution and turning angle of NACA root section.

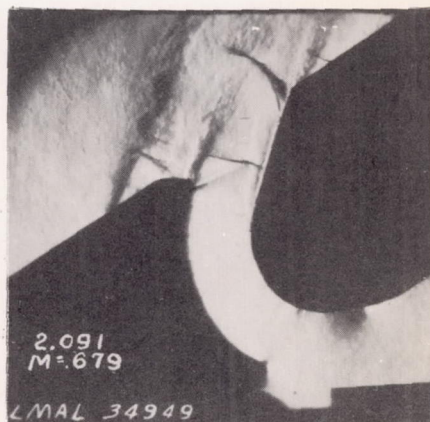
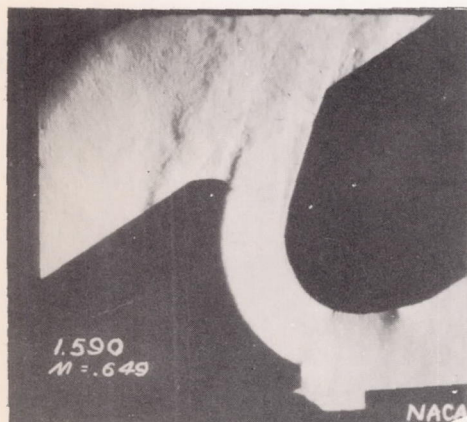
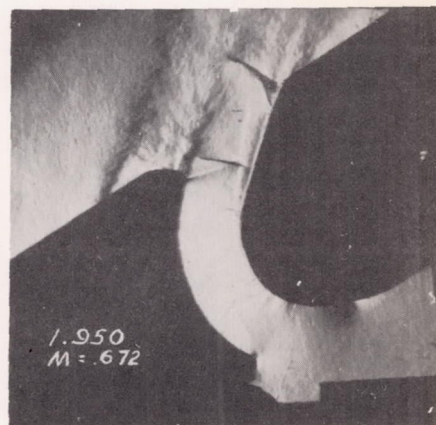
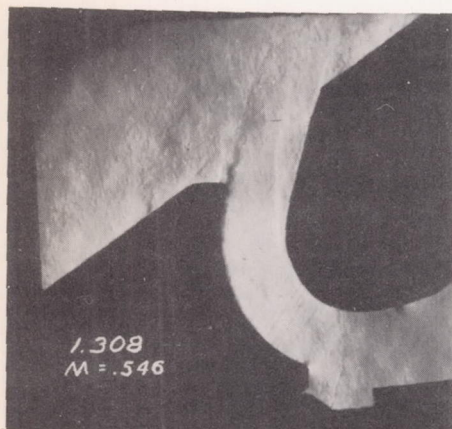
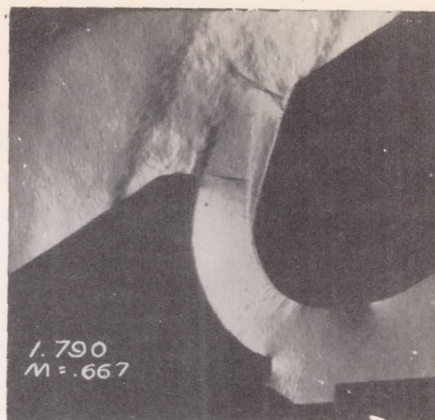
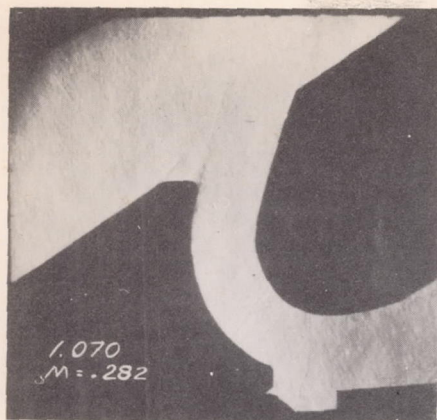

Figure 7.- Schlieren photographs of flow through original root section.  $\xi_r = 0.404$ ;  $\beta = 56.5^\circ$ . Upper numbers indicate chamber pressures in atmospheres; lower numbers, entrance Mach numbers. Choking occurred at an entrance Mach number of 0.67.

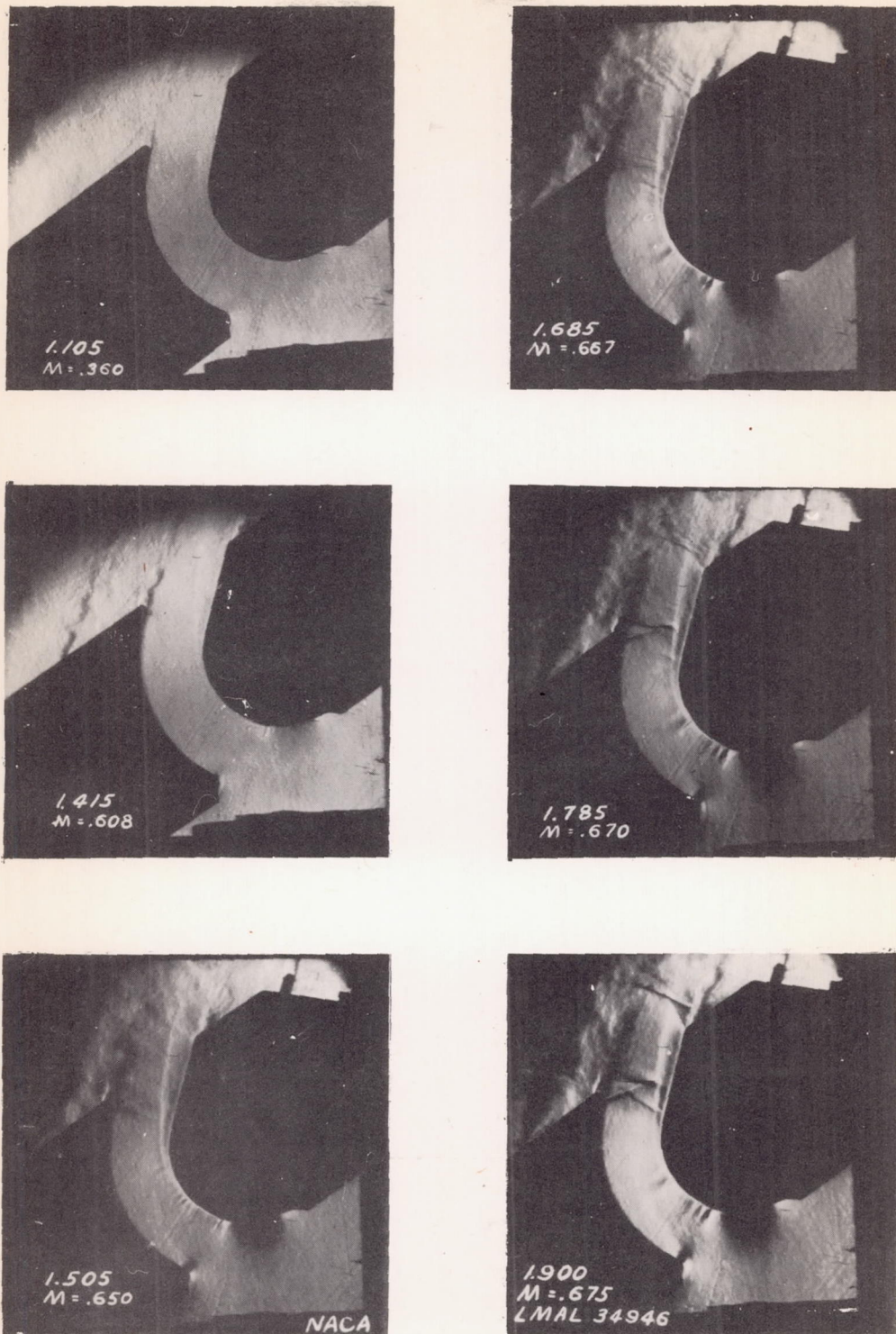
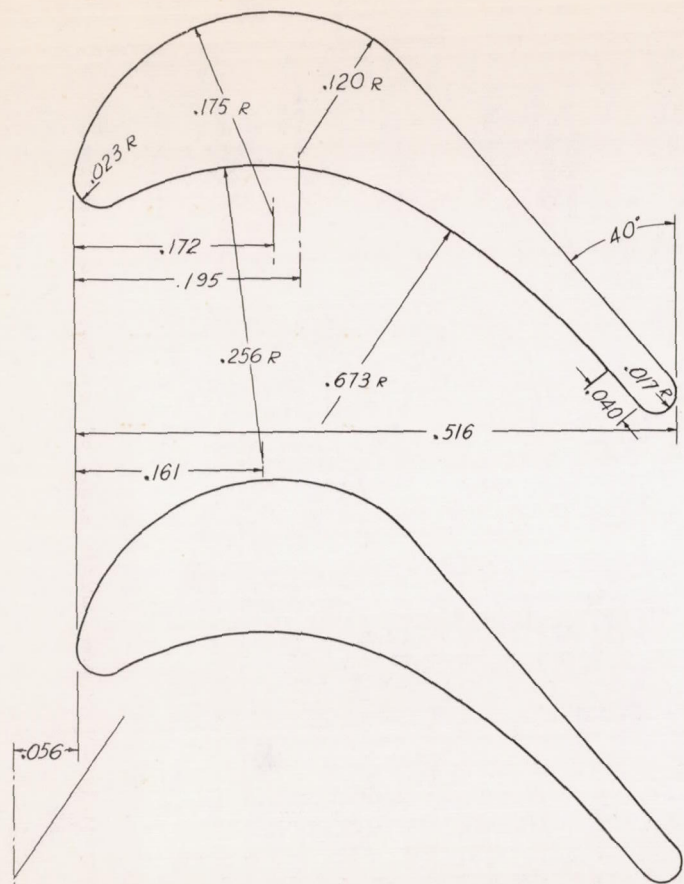
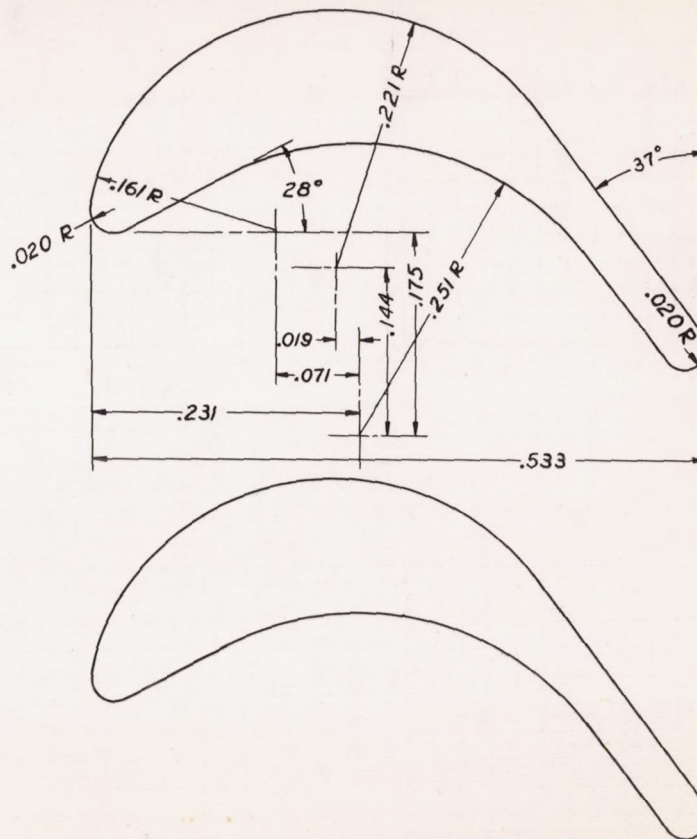

Figure 8.- Schlieren photographs of flow through NACA root section.  $\xi_r = 0.404$ ;  $\beta = 56.5^\circ$ . Upper numbers indicate chamber pressures in atmospheres; lower numbers, entrance Mach numbers. Choking occurred at an entrance Mach number of 0.67.



NATIONAL ADVISORY  
COMMITTEE FOR AERONAUTICS

Figure 9.- Original bucket pitch section.  
All dimensions are in inches.



NATIONAL ADVISORY  
COMMITTEE FOR AERONAUTICS

Figure 10.- Bucket pitch section designed by NACA.  
All dimensions are in inches.

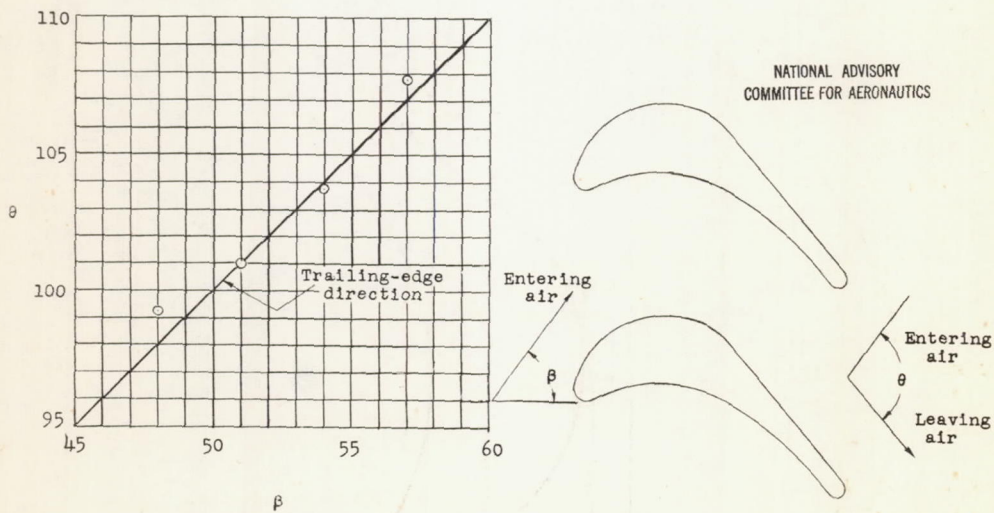
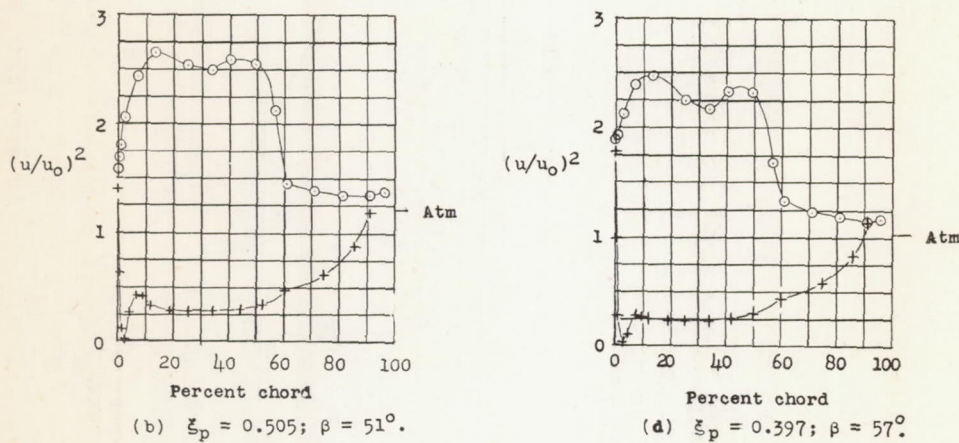
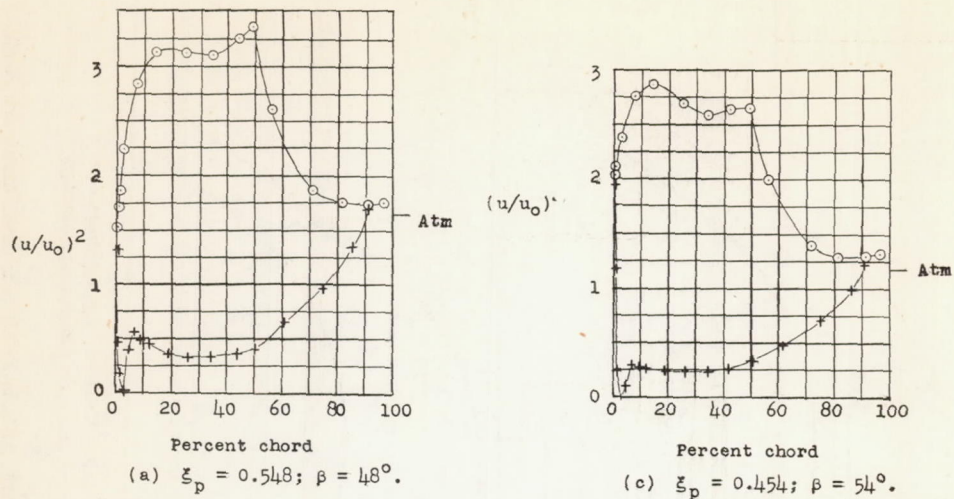
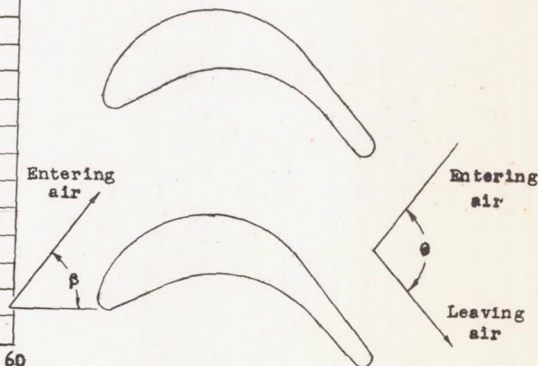
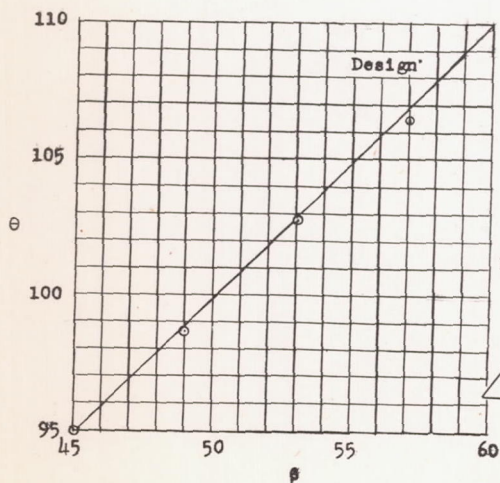
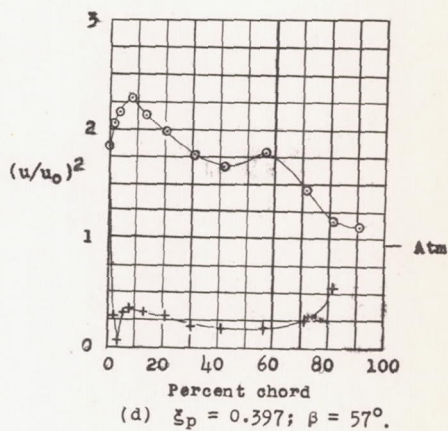
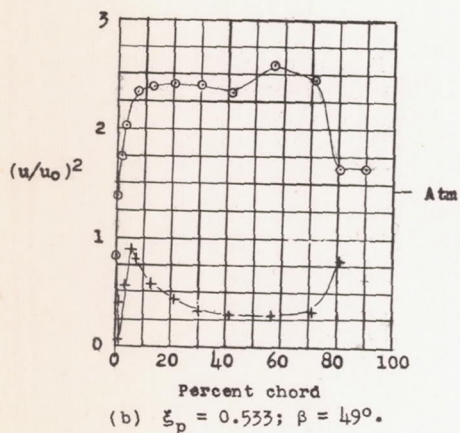
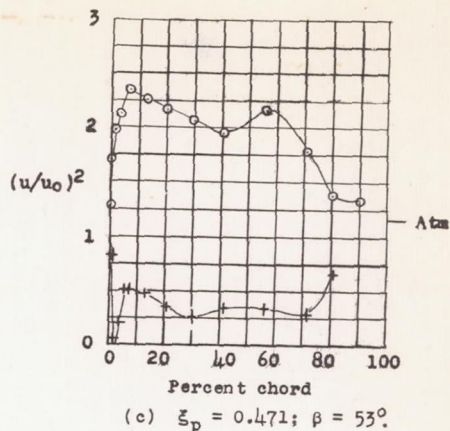
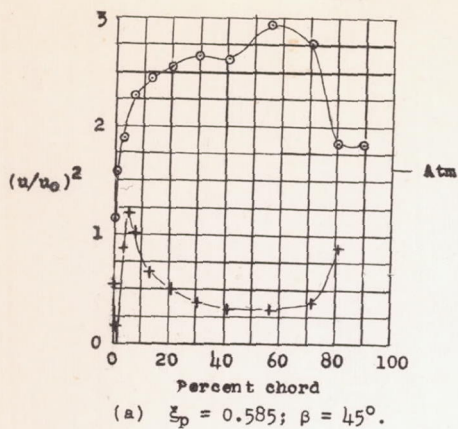

Figure 11.- Velocity distribution and turning angle of original pitch section.



NATIONAL ADVISORY  
COMMITTEE FOR AERONAUTICS

Figure 12.- Velocity distribution and turning angle of NACA pitch section.

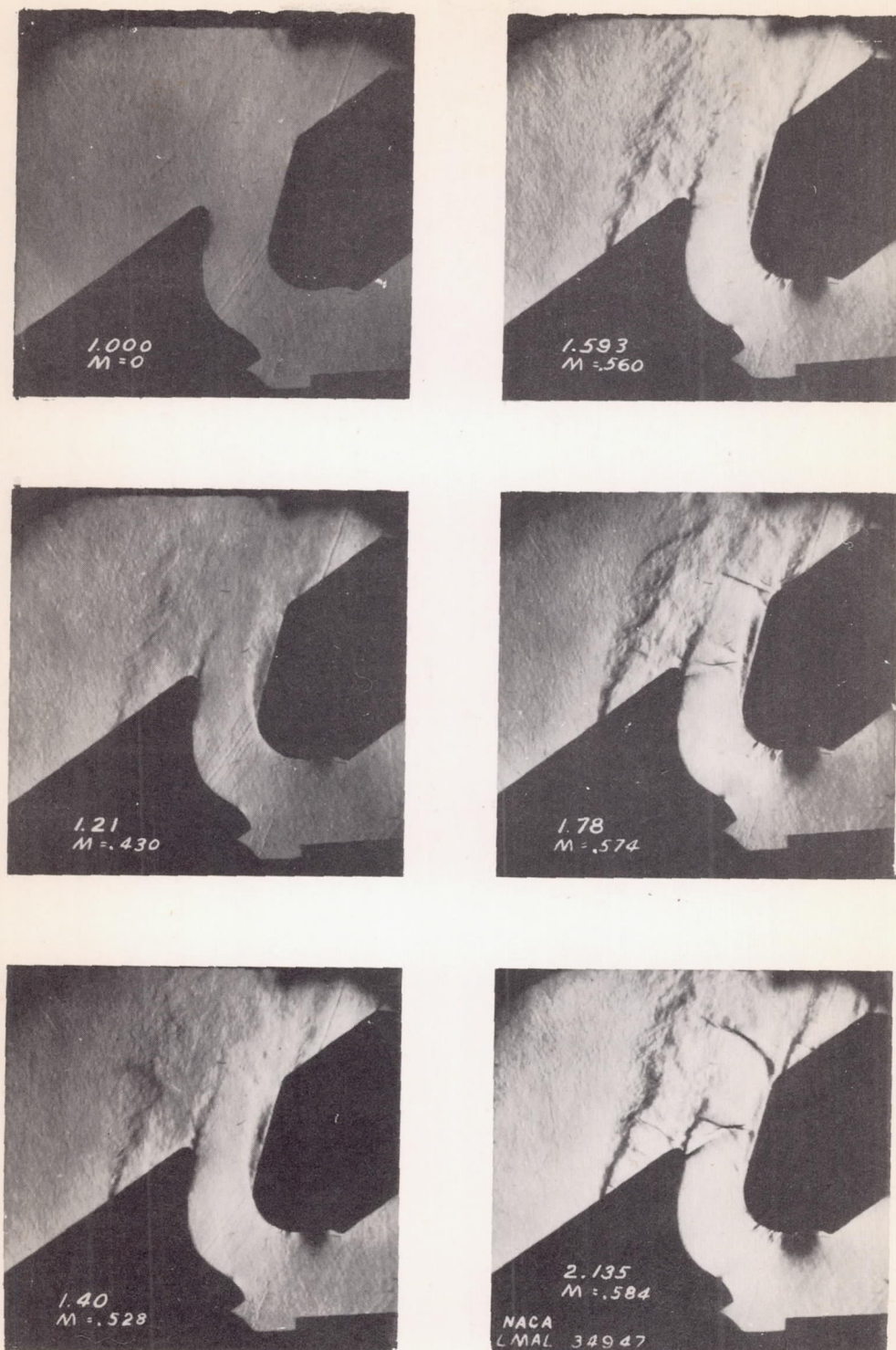

Figure 13.- Schlieren photographs of flow through original pitch section.  $\xi_p = 0.450$ ;  $\beta = 54^\circ$ . Upper numbers indicate chamber pressures in atmospheres; lower numbers, entrance Mach numbers. Choking occurred at an entrance Mach number of 0.58.

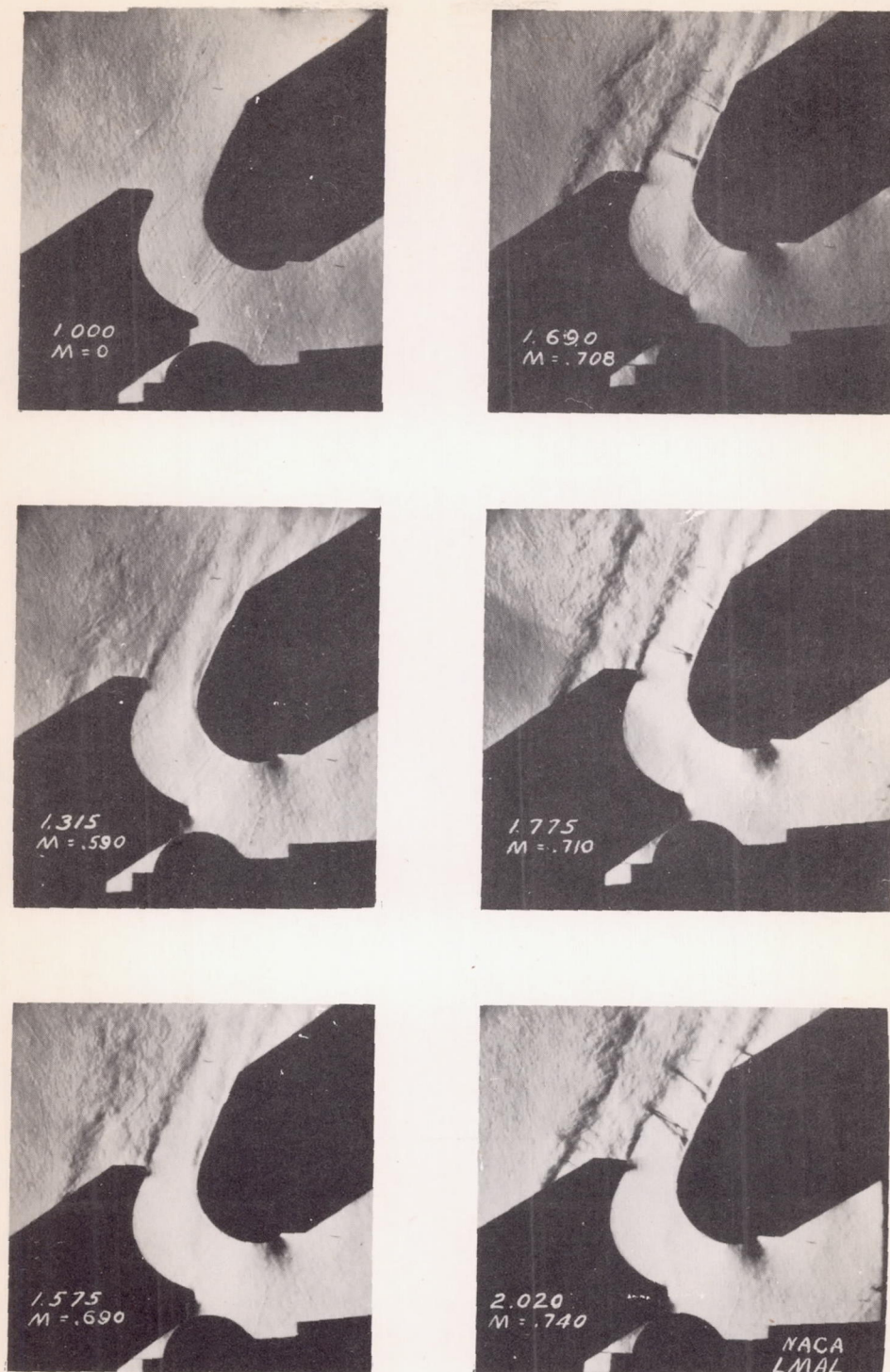

Figure 14.- Schlieren photographs of flow through NACA pitch section.  $\xi_p = 0.450$ ;  $\beta = 54^\circ$ . Upper numbers indicate chamber pressures in atmospheres; lower numbers, entrance Mach numbers. Choking occurred at an entrance Mach number of 0.72.

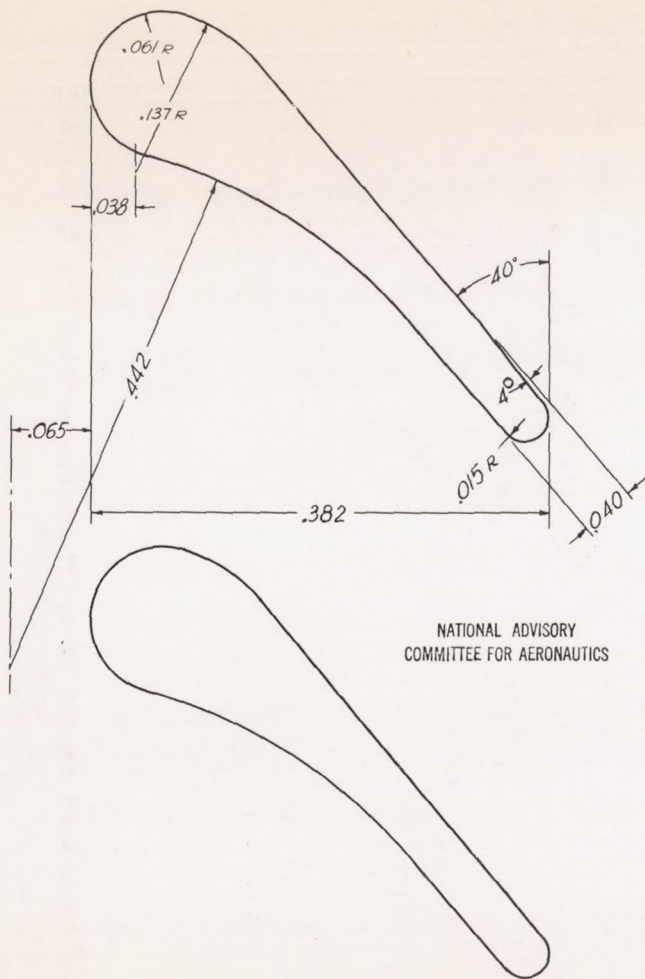

Figure 15.- Original bucket tip section.  
All dimensions are in inches.

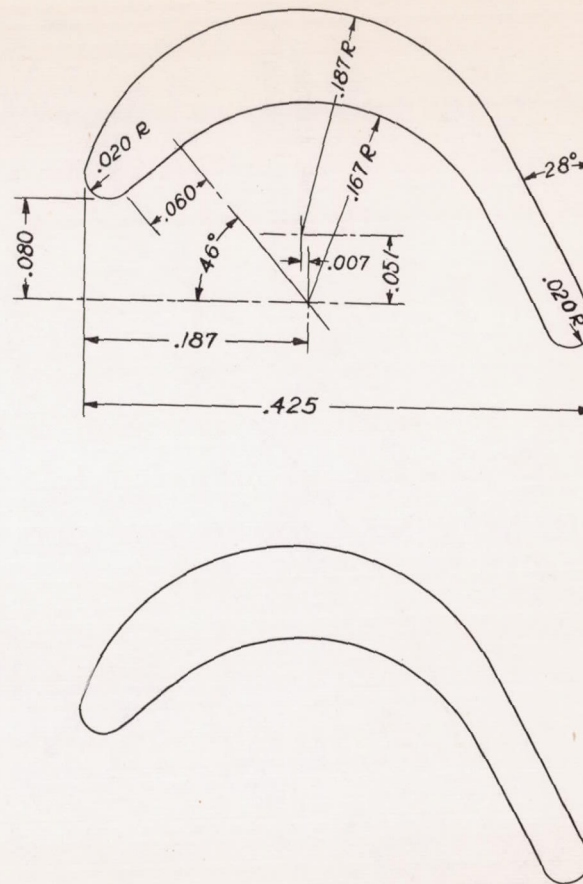

Figure 16.- Bucket tip section designed by NACA.  
All dimensions are in inches.

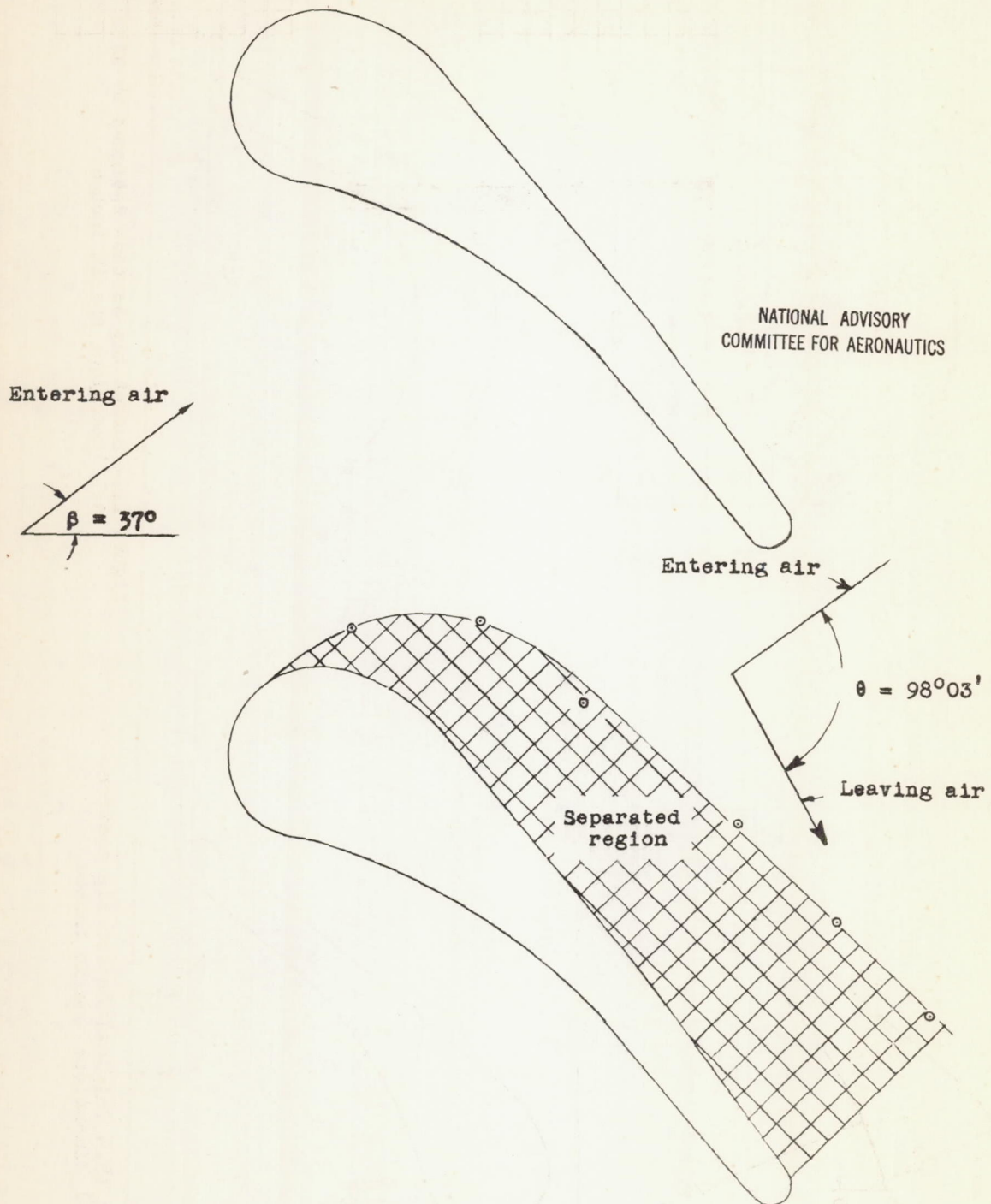

Figure 17.- Separated region of original tip section for  $\xi_t = 0.672$ .

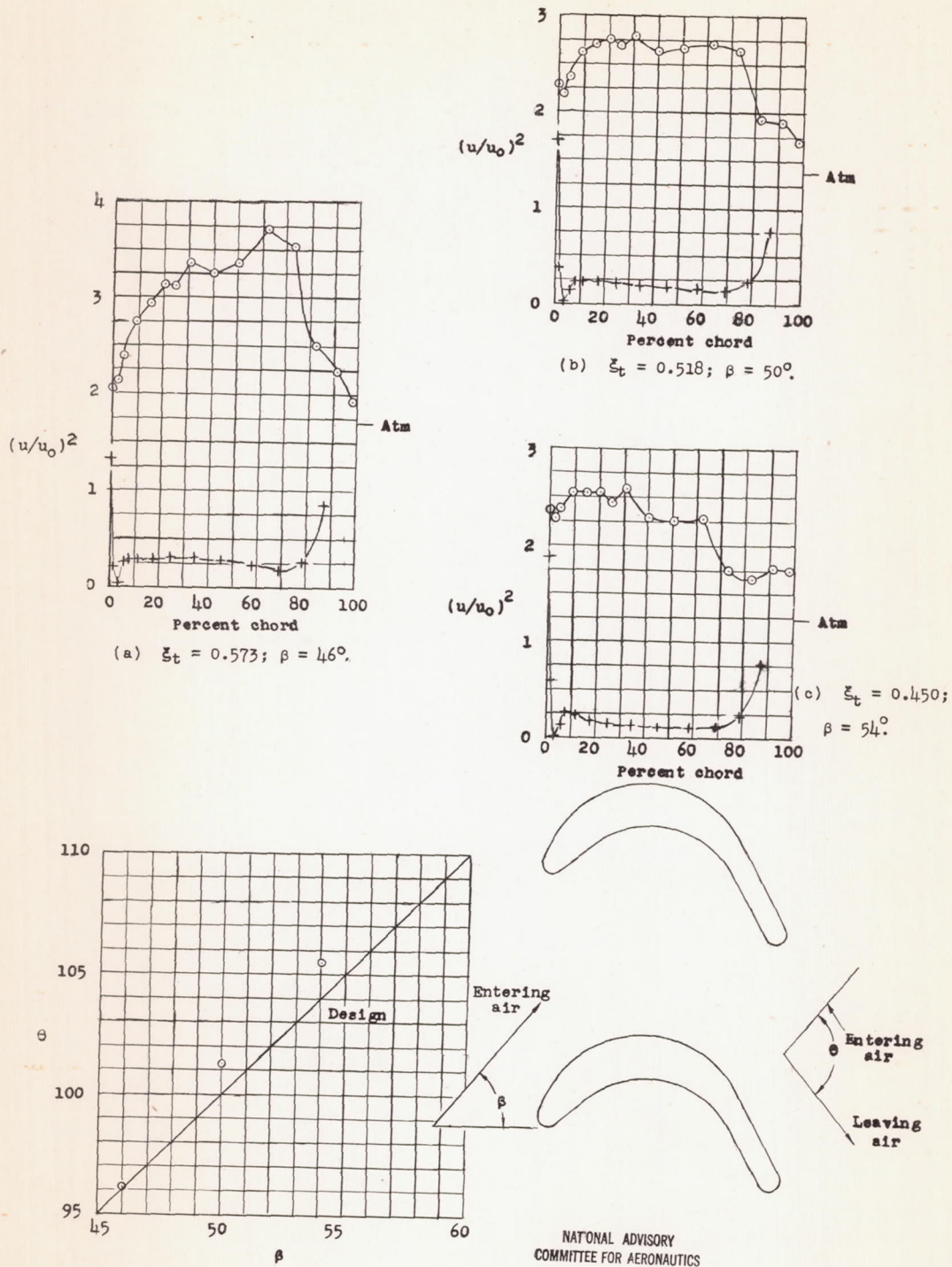

Figure 18.- Velocity distribution and turning angle of NACA tip section.

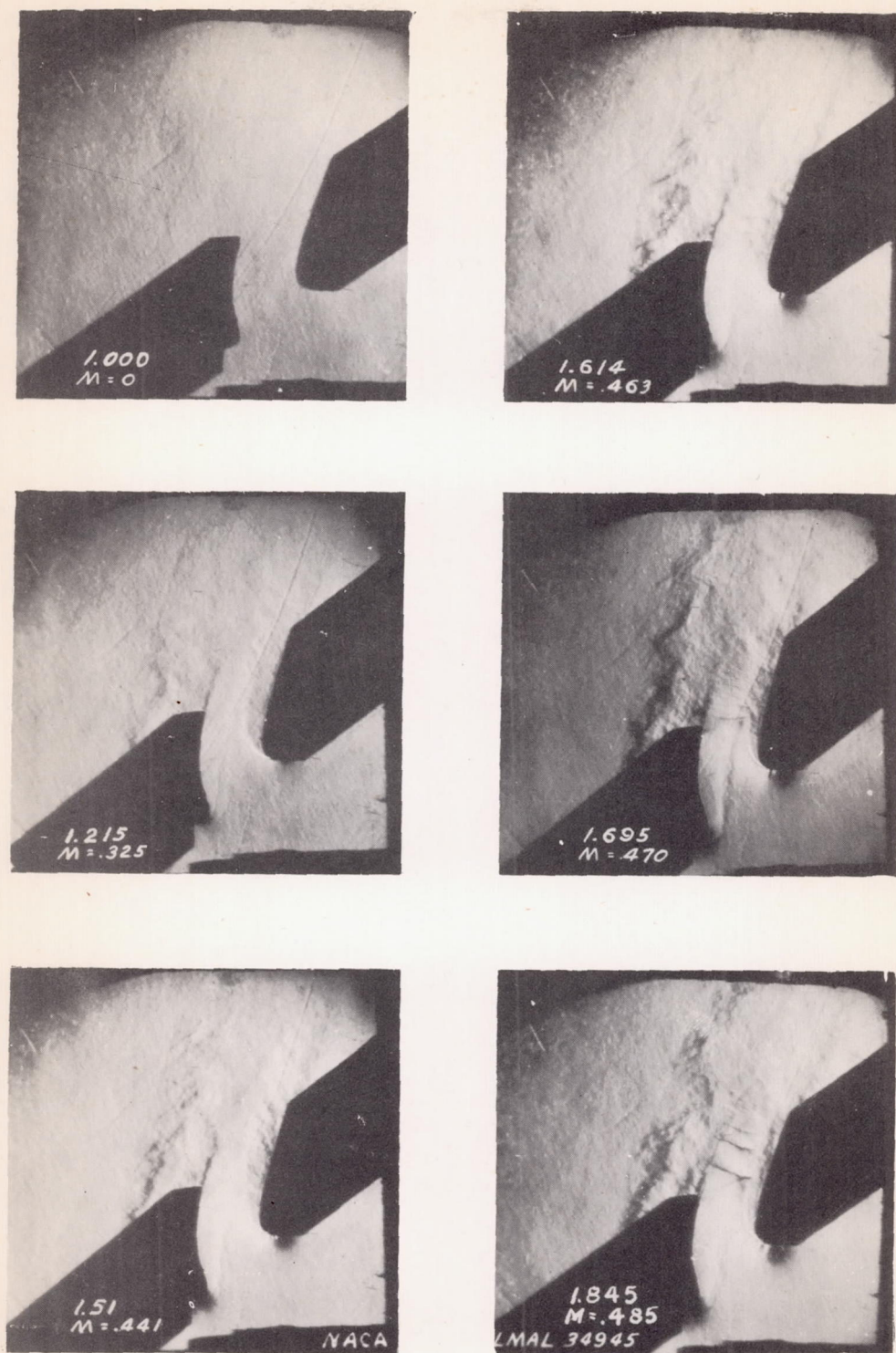

Figure 19.-- Schlieren photographs of flow through original tip section.  $\xi_t = 0.496$ ;  $\beta = 52^\circ$ . Upper numbers indicate chamber pressures in atmospheres; lower numbers, entrance Mach numbers. Choking occurred at an entrance Mach number of 0.48.

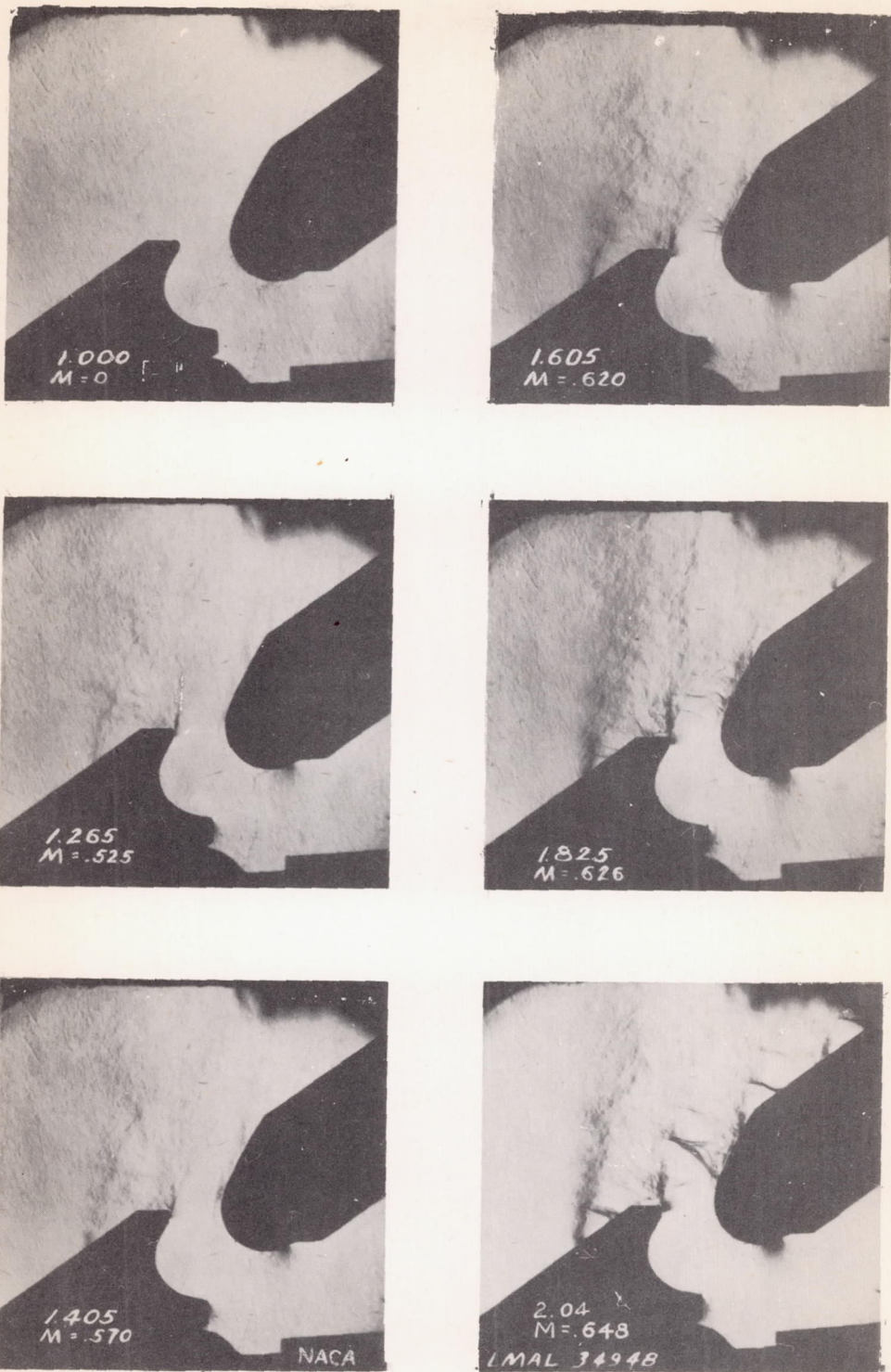

Figure 20.- Schlieren photographs of flow through NACA tip section.  $\xi_t = 0.496$ ;  $\beta = 52^\circ$ . Upper numbers indicate chamber pressures in atmospheres; lower numbers, entrance Mach numbers. Choking occurred at an entrance number of 0.63.

TDIC FORM 69 (13 FEB 47)

Kantrovitz, A  
Erwin, John R.

DIVISION: Power Plants, Reciprocating (6)  
SECTION: Induction and Supercharging (2)  
CROSS REFERENCES: Turbo superchargere (95550); Turbine  
blades - Aerodynamics (95302).

ATI-13414

ORIG. AGENCY NUMBER  
ACR-14J25

REVISION

AUTHOR(S)

AMER. TITLE: Cascade investigation of buckets for a modern aircraft turbosupercharger

FORG'N. TITLE:

ORIGINATING AGENCY: National Advisory Committee for Aeronautics, Washington, D. C.

TRANSLATION:

COUNTRY	LANGUAGE	FORG'N CLASS	U. S. CLASS.	DATE	PAGES	ILLUS.	FEATURES
U.S.	Eng.		Unclass.	Nov '44	25	20	photos, diagrs, graphs

ABSTRACT

Original bucket sections of conventional and NACA designs for turbosupercharger were tested. Velocity distribution and turning angle were obtained for operating range of velocity ratio. Schlieren photographs of high-speed flow about all buckets tested are presented with measurements of maximum Mach number attainable ahead of cascade. NACA turbine bucket sections showed promise of significant improvements. Rotating machine tests are needed to make improvements measurable directly in terms of lowered back pressure on engine or increased turbosupercharger performance

NOTE: Request for copies of this report must be addressed to N.A.C.A., Washington, D.C.

T-2, HQ., AIR MATERIEL COMMAND

AIR TECHNICAL INDEX

WRIGHT FIELD, OHIO, USAF

17-0-21 MAR 47