



3 1176 00103 7424

U 112 P 3
65 (112) A111/1

NATIONAL ADVISORY COMMITTEE FOR AERONAUTICS

9 OCT 1947

TECHNICAL NOTE

No. 1463

INVESTIGATION OF NACA 65⁽¹¹²⁾A111 (APPROX.)
AIRFOIL WITH 0.35-CHORD SLOTTED FLAP AT
REYNOLDS NUMBERS UP TO 25 MILLION

By Stanley F. Racisz

Langley Memorial Aeronautical Laboratory
Langley Field, Va.



Washington

October 1947

FOR REFERENCE

NOT TO BE TAKEN FROM THIS ROOM

NACA LIBRARY
LANGLEY MEMORIAL AERONAUTICAL
LABORATORY
Langley Field, Va.

NATIONAL ADVISORY COMMITTEE FOR AERONAUTICS

TECHNICAL NOTE NO. 1463

INVESTIGATION OF NACA 65(112)A111 (APPROX.)

AIRFOIL WITH 0.35-CHORD SLOTTED FLAP AT

REYNOLDS NUMBERS UP TO 25 MILLION

By Stanley F. Racisz

SUMMARY

An investigation has been made in the Langley two-dimensional low-turbulence tunnel and the Langley two-dimensional low-turbulence pressure tunnel to determine the highest maximum lift configurations (ideal configurations) of a 0.35-chord slotted flap on an NACA 65(112)A111 (approx.) airfoil section. The scale effects on the aerodynamic characteristics were determined for Reynolds numbers ranging from 2.4×10^6 to approximately 25.0×10^6 .

Increasing the Reynolds number from 2.4×10^6 to 9.0×10^6 decreased the flap deflection for highest maximum lift from 45° to 40° and 35° (deflections of 40° and 35° gave same maximum lift). Increasing the Reynolds number caused the flap position for highest maximum lift to move upward approximately 1 percent of the airfoil chord for flap deflections of 35° and 40° and also rearward for a flap deflection of 35° . The flap configuration with the center of the flap leading-edge radius located 1.98 percent chord behind and 3.21 percent chord below the slot lip at a flap deflection of 35° was the optimum configuration. A maximum increase of only 0.1 in the value of the maximum section lift coefficient was obtained at a Reynolds number of 9.0×10^6 by shifting the flap from the position giving the highest maximum lift at a Reynolds number of 2.4×10^6 . In general, increasing the Reynolds number delayed the stall to higher section angles of attack and also caused a more gradual stall for both the flap-retracted and the flap-deflected configurations. The maximum section lift coefficients for the flap-retracted configuration increased as Reynolds number increased to 18.0×10^6 and then decreased slightly with further increase in Reynolds number; the coefficients for the flap-deflected configuration increased as the Reynolds number increased to a value of 13.0×10^6 and then decreased slightly. The increment of maximum section lift coefficient due to the slotted flap increased from 1.24 to 1.36 as the Reynolds number was increased from 3.0×10^6 to about 12.0×10^6 and then decreased to 1.31 as

the Reynolds number increased up to about 25.0×10^6 . At section lift coefficients outside the low-drag range, the section drag coefficient decreased as the Reynolds number increased throughout the test range of Reynolds number.

INTRODUCTION

The use of thin wing sections to increase the critical speeds of high-speed airplanes has led to the need for high-lift flaps in take-off and landing. Large wing chords and the trend toward higher take-off and landing speeds have increased the Reynolds number for which the airfoil section with the flap must provide the required high lift up to values approaching 25.0×10^6 . At high Reynolds numbers, the ideal flap configuration (flap configuration for highest maximum lift) may be considerably different from that at low Reynolds numbers because of changes in the boundary-layer characteristics and the flow conditions through the slot. The range of Reynolds number covered in experimental investigations such as those reported in reference 1 has generally been limited to about 9.0×10^6 . Although a limited amount of data for Reynolds numbers higher than 9.0×10^6 are available for thin airfoils equipped with slotted flaps, the large scale effects on maximum lift coefficient at Reynolds numbers below 9.0×10^6 , illustrated in reference 1, indicate that the maximum lift coefficient may continue to vary considerably with Reynolds number as the Reynolds number is increased to values above 9.0×10^6 .

An NACA 65(112)A111 (approx.) airfoil section equipped with a 0.35-chord slotted flap has been tested in the Langley two-dimensional low-turbulence tunnels to determine whether the ideal flap configuration is dependent upon the Reynolds number and to determine the scale effects on the aerodynamic characteristics for Reynolds numbers up to 25.0×10^6 .

SYMBOLS

- α_0 section angle of attack, degrees
- c airfoil chord (flap retracted)
- c_d section drag coefficient

$c_{d_{min}}$	minimum section drag coefficient
c_l	section lift coefficient
$c_{l_{max}}$	maximum section lift coefficient
$\Delta c_{l_{max}}$	increment of maximum section lift coefficient
$c_{m_c/4}$	section pitching-moment coefficient about airfoil quarter-chord point
x, y	horizontal and vertical positions, respectively, of center of flap leading-edge radius with respect to upper lip of slot. in percent c (x positive forward of slot lip and y positive below slot lip (fig. 1))
δ_f	flap deflection, degrees
R	Reynolds number

MODEL

The 2-foot-chord model tested in the present investigation was approximately an NACA 65(112)All1 airfoil section with a 0.35 c slotted flap. The NACA 6A-series airfoils, which may be derived by the method discussed in reference 2, were designed to eliminate the trailing-edge cusp of the NACA 6-series airfoils. The NACA 65(112)All1 airfoil was derived by a different method, but the resulting section is approximately the same as would be obtained from reference 2. Ordinates for the airfoil section and the flap are given in tables I and II, respectively. A sketch of the model showing the essential dimensions and the reference points defining the flap position is presented as figure 1. The model, constructed of aluminum alloy, completely spanned the 3-foot-wide test section. Photographs of the model with the flap deflected are presented as figure 2. The method of attaching the flap to the main part of the model, as shown in figure 2(a), permitted an extensive variation of the flap position for each flap deflection. Although the slot was closed when the flap was retracted, a plasteline seal was inserted in the slot to prevent any leakage of air which could result from small changes in the model surfaces during tests with the flap retracted. The seal was removed for tests of the model with the flap deflected. For most of the tests the model surfaces were aerodynamically smooth. For the condition with leading-edge roughness the surfaces were the same as those for the smooth

condition except that 0.011-inch carborundum grains had been applied over a surface length of 0.08c at the airfoil leading edge on both surfaces. The roughness configuration corresponded to the standard roughness described in reference 3.

TESTS

Tests of the model were made in the Langley two-dimensional low-turbulence tunnel (LTT) to determine the ideal flap configuration (flap configuration for highest $c_{l_{max}}$) at a Reynolds number of 2.4×10^6 . These tests consisted of measurements of the maximum section lift coefficients for an extensive range of flap position at several flap deflections. The section lift characteristics for an extensive range of angle of attack were determined for the ideal flap positions. Similar tests were made in the Langley two-dimensional low-turbulence pressure tunnel (TDT) to find the ideal configuration at a Reynolds number of 9.0×10^6 and to obtain an indication of the effects of Reynolds number on the ideal configuration. The highest tunnel pressure at which alterations of the flap configuration could be made within the tunnel was 4 atmospheres absolute. The tests of the flap-deflected configurations were therefore limited to a Reynolds number of 9.0×10^6 which was the highest obtainable at that pressure without exceeding a tunnel Mach number of approximately 0.2. The scale effects on the aerodynamic characteristics for Reynolds numbers ranging from 2.4×10^6 to approximately 25.0×10^6 were then determined for the flap configuration selected as the optimum. The section lift characteristics for intermediate flap deflections were determined at a Reynolds number of 9.0×10^6 . The scale effects on the section lift and drag characteristics of the airfoil section with the flap retracted were determined at Reynolds numbers ranging from 3.0×10^6 to approximately 25.0×10^6 . The section pitching-moment characteristics and the effects of leading-edge roughness on the section lift and drag characteristics were determined at Reynolds numbers ranging from 3.0×10^6 to 9.0×10^6 .

A discussion of the test methods used in the LTT and the TDT and of the methods used in correcting the test data to free-air conditions is given in reference 3. The maximum free-stream Mach

numbers attained during tests in the LTT and TDT are given in the following table:

Reynolds number	Mach number
2.4×10^6	0.16
3.0	.10
6.0	.14
9.0	.16
12.0	.14
18.0	.14
25.0	.18

RESULTS AND DISCUSSION

The terms "ideal deflection" and "ideal position" are used herein to designate the flap deflection and flap position, respectively, for the highest value of $c_{l_{max}}$ at a particular Reynolds number. The term "ideal configuration" is used to designate the flap configuration described by the flap deflection and position for the highest value of $c_{l_{max}}$.

Flap Configurations

Ideal configuration at $R = 2.4 \times 10^6$.—Contours for constant values of $c_{l_{max}}$ for various positions of the center of the flap leading-edge radius at flap deflections of 35° , 40° , and 45° are presented in figure 3. The ideal position for each of the flap deflections tested is also shown. The tests were limited to a flap deflection of 45° because at that deflection the flow over the flap was stalled throughout most of the range of angle of attack and the increase in the value of $c_{l_{max}}$ resulting from increasing the deflection from 40° to 45° was only 0.05. That any significant increase in the value of $c_{l_{max}}$ would have been obtained by increasing the flap deflection beyond 45° is therefore unlikely because more severe stalling of the flap could be expected to occur at higher flap deflections. The ideal configuration at a Reynolds number of 2.4×10^6 as shown in figure 3 was a flap deflection of 45° with the center of the flap leading-edge radius located 0.73 percent chord behind and 4.46 percent chord below the slot lip. The ideal

deflection was the same as that found to be the ideal for the 0.25c slotted flap, designated as slotted flap 1 in reference 1, on the NACA 65-210 airfoil section. The ideal position varied only about 1 percent chord as the flap deflection increased from 35° to 45° .

The section lift characteristics of the model with the flap located in the positions found to be the ideal at a Reynolds number of 2.4×10^6 for the three flap deflections tested are presented in figure 4. At flap deflections of 40° and 45° , the slopes of the lift curves at section angles of attack slightly below the stall are considerably higher than the slopes of the curves at low section angles of attack. Tuft studies of the air flow over the flap at a deflection of 40° indicated that the flow over the flap was stalled throughout most of the angle-of-attack range but unstalled at angles of attack slightly below the angle of attack for maximum lift. A less pronounced change in lift at high angles of attack was obtained at a flap deflection of 40° by shifting the flap position forward of and upward from the ideal position with a consequent reduction in the value of $c_{l,max}$.

Ideal configuration at $R = 9.0 \times 10^6$. - The values of $c_{l,max}$ measured at a Reynolds number of approximately 9.0×10^6 for several flap configurations including those found to be the ideal at a Reynolds number of 2.4×10^6 are presented in figure 5. The highest maximum section lift coefficients measured at flap deflections of 35° and 40° at a Reynolds number of 9.0×10^6 were almost the same and therefore either one of the two flap deflections could be selected as the ideal. A flap deflection of 35° , however, would be more suitable than a flap deflection of 40° inasmuch as a lower drag could be expected for that flap deflection. A comparison of the data presented in figures 3 and 5 indicates that increasing the Reynolds number from 2.4×10^6 to approximately 9.0×10^6 decreased the ideal deflection by at least 5° . Increasing the Reynolds number from 2.4×10^6 to 9.0×10^6 caused the ideal position to move upward for flap deflections of 35° and 40° and also rearward for a flap deflection of 35° . These changes in the ideal position resulting from the increase in Reynolds number were slightly less than 1 percent chord as indicated by the data presented in figure 5. The largest increase in the value of $c_{l,max}$ at a Reynolds number of 9.0×10^6 obtained by shifting the flap position from that found to be the ideal at a Reynolds number of 2.4×10^6 was only 0.1.

The section lift characteristics at a Reynolds number of 9.0×10^6 for several positions of the flap including those found

to be the ideal at a Reynolds number of 2.4×10^6 are presented in figure 6. A comparison of the lift curves obtained for flap deflections of 35° and 40° indicates that variations in flap position have less effect on the section lift coefficient at low angles of attack for a flap deflection of 35° than for a flap deflection of 40° . For example, at a flap deflection of 40° , shifting the position changed the section lift coefficient at an angle of attack of 0° by 0.5; whereas, for a flap deflection of 35° , the change in the section lift coefficient at low angles of attack was about 0.1.

Optimum configuration.— The ideal configuration at high Reynolds numbers would probably be more closely approximated by that found to be the ideal at a Reynolds number of 9.0×10^6 than the ideal configuration determined at a Reynolds number of 2.4×10^6 . An estimate of an optimum configuration at high Reynolds numbers was therefore made from the results obtained at a Reynolds number of 9.0×10^6 . Although the highest maximum section lift coefficients for flap deflections of 35° and 40° were almost the same at a Reynolds number of 9.0×10^6 , the flap deflection of 35° would probably be more suitable because of lower drag, smaller change in lift at low angles of attack with flap position, and less complicated structure resulting from the smaller flap deflection along with the smaller variation of lift coefficient with Reynolds number at low angles of attack (fig. 6). For a flap deflection of 40° , increasing the Reynolds number from 2.4×10^6 to 9.0×10^6 caused a change of 0.25 in the section lift coefficient at a section angle of attack of 0° ; whereas, for a flap deflection of 35° , the change was only 0.05. The flap deflection of 35° was therefore selected as the optimum deflection. Inasmuch as increasing the Reynolds number caused a rearward and upward shift in the ideal position of the flap for a deflection of 35° (fig. 5), the position with the center of the flap leading-edge radius located 1.98 percent c behind and 3.21 percent c below the slot lip would probably be a sufficiently accurate approximation of the ideal position at high Reynolds numbers. The resulting flap configuration $\delta_f = 35^\circ$, $x = -1.98$ percent c , and $y = 3.21$ percent c , which will hereinafter be referred to as the "optimum configuration," was the configuration tested at Reynolds numbers up to 25.0×10^6 .

Lift Characteristics

Scale effects on maximum lift.— The section lift characteristics of the airfoil with the flap-retracted configuration and with the optimum configuration are presented in figures 7 and 8 for several Reynolds numbers ranging from 3.0×10^6 to 25.3×10^6 . The variation

of maximum section lift coefficient and increment of maximum section lift coefficient due to the 0.35c slotted flap with Reynolds number are presented in figure 9. The maximum section lift coefficient of the model with the flap retracted increased from 1.17 to 1.35 as the Reynolds number increased from 3.0×10^6 to 18.0×10^6 and then decreased to 1.30 as the Reynolds number increased up to 24.9×10^6 . The maximum section lift coefficient of the model with the optimum configuration increased from 2.15 to 2.71 as the Reynolds number increased from 2.4×10^6 to 13.0×10^6 and then decreased to 2.62 as the Reynolds number increased up to 25.3×10^6 . The increment of maximum section lift coefficient, shown in figure 9, increased from 1.24 to 1.36 as the Reynolds number was increased from 3.0×10^6 to about 12.0×10^6 and then decreased to 1.31 as the Reynolds number was increased to about 25.0×10^6 .

Some of the data obtained at the lower Reynolds numbers may be compared with data given for the NACA 65-210 airfoil with the 0.25c slotted flap designated as slotted flap 1 in reference 1 and data obtained for the NACA 23012 airfoil section with the 0.40c slotted flap designated as flap 1-a in reference 4. The data for the NACA 65-210 and NACA 23012 airfoil sections with slotted flaps have been included with the data presented in figure 9. The differences in the values of $\Delta c_{l_{max}}$ for the three airfoil sections can be ascribed to differences in the flap chord.

Angle of attack for maximum lift.- The data presented in figures 7 and 8 indicate that for the flap-retracted configuration increasing the Reynolds number from 3.0×10^6 to approximately 12.0×10^6 increased the section angle of attack for $c_{l_{max}}$ by about 2° ; whereas for the optimum configuration with the flap deflected, the angle of attack for $c_{l_{max}}$ was increased by as much as 5° . The increase in the angle of attack for maximum section lift coefficient with increase in Reynolds number was accompanied by a more gradual stall. Increasing the Reynolds number beyond approximately 12.0×10^6 had smaller effects on the angle of attack for maximum lift and on the stall than those obtained at low Reynolds numbers.

Lift at low angles of attack.- The variation of section lift coefficient with Reynolds number at a constant section angle of attack is shown in figure 10. Slight reductions in the section lift coefficient at a section angle of attack of -8.1° , or positive increases in the angle of attack for zero lift, were obtained for the optimum flap configuration as the Reynolds number was increased beyond approximately 12.0×10^6 . The variation of the angle of attack for zero lift with Reynolds number may be ascribed to changes

in the flow through the slot. These flow changes probably result in a variation of the ideal configuration with Reynolds number. For the flap-retracted condition, however, the section lift coefficient at a section angle of attack of 0° remained substantially independent of the Reynolds number.

Intermediate flap deflections.- The flap was deflected along a circular-arc path so that the configuration resulting at a flap deflection of 35° corresponded to the optimum configuration. A line connecting the pivot point and station 0.780c on the airfoil chord line was always perpendicular to the airfoil chord line and therefore the flap position was determined by the flap deflection. The location of the pivot point about which the flap was deflected and sketches of the flap configurations for several flap deflections are shown in figure 11.

The section lift characteristics at a Reynolds number of 9.0×10^6 for flap deflections up to a deflection of 35° are presented in figure 12. At a flap deflection of 20° and at section angles of attack higher than about -4° , two values of the section lift coefficient were obtained at each angle of attack although the maximum section lift coefficient remained nearly the same. Repeat tests indicated that the condition giving the lower lift coefficients was the more stable of the two. Tuft studies at a flap deflection of 20° indicated that the irregular behavior of the lift coefficients was associated with partial stalling of the flap caused by the relatively poor slot shape for this flap deflection. Increasing the flap deflection to 30° unstalled the flow over the flap and the flow remained unstalled throughout most of the angle-of-attack range although unsteady flow conditions existed near the trailing edge at low angles of attack. The data presented in figure 12 indicate that the increase in maximum section lift coefficient and the decrease in the angle of attack for maximum lift caused by deflecting the flap was approximately a linear function of the flap deflection within the range of flap deflection investigated. Although tests were not made for the configuration corresponding to a flap deflection of 40° with the flap position as determined by the flap path, the maximum section lift coefficient would probably not be so high as that obtained for a flap deflection of 35° because the flap would be an appreciable distance behind the slot lip.

Pitching-Moment Characteristics

The section pitching-moment characteristics of the airfoil section with the flap retracted for Reynolds numbers ranging from

3.0×10^6 to 9.1×10^6 are presented in figure 13. Increasing the Reynolds number from 3.0×10^6 to 9.1×10^6 caused only small changes in the section pitching-moment coefficient at section angles of attack below the stall.

The section pitching-moment characteristics at a Reynolds number of 6.0×10^6 for the airfoil section with the optimum configuration are presented in figure 14. The slope of the pitching-moment curve was positive at angles of attack from about 2° to slightly above the stall. From this point, increases in the section angle of attack caused the slope of the pitching-moment curve to become negative. The value of the section pitching-moment coefficient throughout most of the range of angle of attack was approximately 0.1 more negative than that measured for the NACA 65-210 airfoil section with the 0.25c slotted flap designated as slotted flap 1 in reference 1 and approximately 0.04 or 0.05 less negative than that obtained for the NACA 65-210 airfoil section with a 0.31c double slotted flap (reference 1).

Drag Characteristics

The section drag characteristics of the airfoil section with the flap retracted for Reynolds numbers ranging from 3.0×10^6 to 24.7×10^6 are presented in figure 15. The minimum section drag coefficient decreased as the Reynolds number increased between Reynolds numbers of 3.0×10^6 and 13.0×10^6 , and increased between Reynolds numbers of 13.0×10^6 and 24.7×10^6 . At section lift coefficients outside the low-drag range, however, the section drag coefficient decreased as the Reynolds number increased throughout the test range of Reynolds number. The range of section lift coefficient for low drag continuously decreased with increase in Reynolds number until at a Reynolds number between 18.0×10^6 and 24.7×10^6 the range of section lift coefficient for low drag was no longer defined by a "bucket."

Effects of Leading-Edge Roughness

The section lift and drag characteristics of the airfoil for the smooth condition and for the condition with standard leading-edge roughness are presented for a Reynolds number of 6.0×10^6 in figure 16. The decrease in the maximum section lift coefficient for the optimum configuration caused by the addition of roughness to the leading edge of the airfoil was approximately the same as that obtained for the airfoil with the flap retracted.

Approximately the same decrement in the maximum section lift coefficient was obtained for the NACA 65-210 airfoil with slotted flap 1 at deflections of 30° and 40° (reference 1). The minimum section drag coefficient for the condition with leading-edge roughness is approximately the same as that estimated from data presented in reference 3 for airfoil sections similar to the NACA 65(112)All1 airfoil.

CONCLUSIONS

The results of tests of an NACA 65(112)All1 (approx.) airfoil section with a 0.35-chord slotted flap in the Langley two-dimensional low-turbulence tunnels at Reynolds numbers ranging from 2.4×10^6 to approximately 25.0×10^6 indicated the following conclusions:

1. Increasing the Reynolds number from 2.4×10^6 to 9.0×10^6 decreased the flap deflection for highest maximum lift from 45° to 40° and 35° (deflections of 40° and 35° gave same maximum lift). Increasing the Reynolds number caused the flap position for highest maximum lift to move upward approximately 1 percent of the airfoil chord for flap deflections of 35° and 40° and also rearward for a flap deflection of 35° . The flap configuration with the center of the flap leading-edge radius located 1.98 percent chord behind and 3.21 percent chord below the slot lip at a flap deflection of 35° was the optimum configuration.
2. A maximum increase of only 0.1 in the value of the maximum section lift coefficient was obtained at a Reynolds number of 9.0×10^6 by shifting the flap from the position giving the highest maximum lift at a Reynolds number of 2.4×10^6 .
3. In general, increasing the Reynolds number delayed the stall to higher section angles of attack and also caused a more gradual stall for both the flap-retracted and the flap-deflected configurations.
4. The maximum section lift coefficients for the flap-retracted configuration increased as Reynolds number increased to 18.0×10^6 and then decreased slightly with further increase in Reynolds number; the coefficients for the flap-deflected configuration increased as the Reynolds number increased to a value of 13.0×10^6 and then decreased slightly.

5. The increment of maximum section lift coefficient due to the slotted flap increased from 1.24 to 1.36 as the Reynolds number was increased from 3.0×10^6 to about 12.0×10^6 and then decreased to 1.31 as the Reynolds number increased up to about 25.0×10^6 .

6. At section lift coefficients outside the low-drag range, the section drag coefficient decreased as the Reynolds number increased throughout the test range of Reynolds number.

Langley Memorial Aeronautical Laboratory
National Advisory Committee for Aeronautics
Langley Field, Va., August 4, 1947

REFERENCES

1. Cahill, Jones F.: Two-Dimensional Wind-Tunnel Investigation of Four Types of High-Lift Flaps on an NACA 65-210 Airfoil Section. NACA TN No. 1191, 1947.
2. Loftin, Laurence K., Jr.: Theoretical and Experimental Data for a Number of NACA 6A-Series Airfoil Sections. NACA TN No. 1368, 1947.
3. Abbott, Ira H., von Doenhoff, Albert E., and Stivers, Louis S., Jr.: Summary of Airfoil Data. NACA ACR No. L5C05, 1945.
4. Harris, Thomas A.: Wind-Tunnel Investigation of an N.A.C.A. 23012 Airfoil with Two Arrangements of a Wide-Chord Slotted Flap. NACA TN No. 715, 1939.

TABLE I
ORDINATES FOR THE
NACA 65(112)A111 (APPROX.) AIRFOIL SECTION

[Stations and ordinates in
percent airfoil chord]

Upper surface		Lower surface	
Station	Ordinate	Station	Ordinate
0	0	0	0
.463	.871	.538	-.821
.708	1.050	.792	-.979
1.204	1.325	1.292	-1.217
2.450	1.813	2.550	-1.625
4.942	2.546	5.054	-2.229
7.442	3.117	7.558	-2.696
9.942	3.600	10.058	-3.083
14.942	4.371	15.054	-3.700
19.950	4.958	20.050	-4.163
24.958	5.404	25.042	-4.508
29.967	5.725	30.033	-4.754
34.975	5.933	35.025	-4.904
39.983	6.033	40.017	-4.965
44.992	6.000	45.008	-4.904
50.000	5.829	50.000	-4.725
55.008	5.508	54.992	-4.413
60.017	5.087	59.983	-4.017
65.021	4.575	64.979	-3.546
70.025	4.029	69.975	-3.054
75.025	3.429	74.975	-2.533
80.025	2.792	79.975	-1.996
85.025	2.146	84.975	-1.471
90.021	1.483	89.979	-.967
95.017	.796	94.983	-.479
100.004	.054	99.996	-.054

L.E. radius: 0.842

NATIONAL ADVISORY
COMMITTEE FOR AERONAUTICS

TABLE II
ORDINATES FOR 0.35-CHORD FLAP

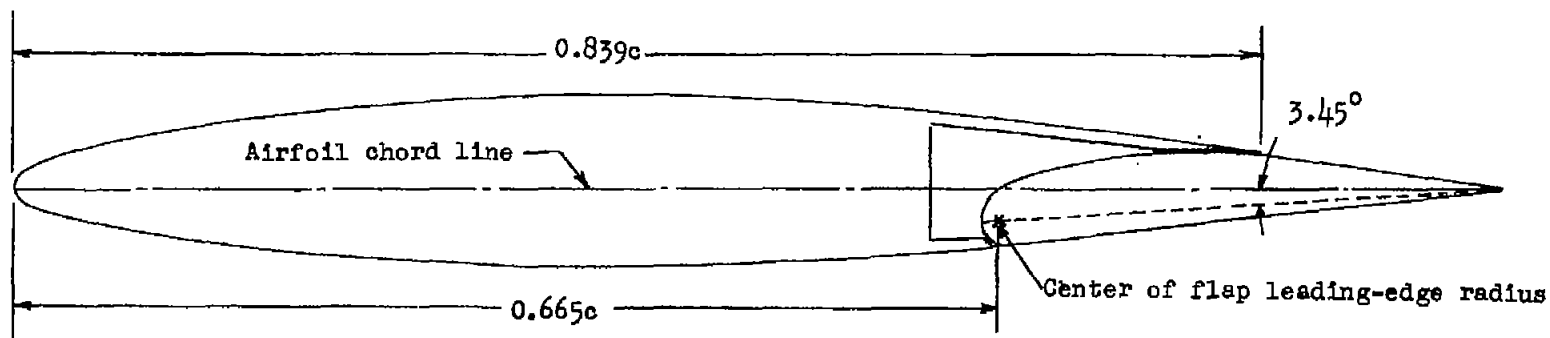
[Stations and ordinates in percent
airfoil chord; lower surface of flap
formed by lower surface of plain
airfoil]

Station	Ordinate
65.50	-0.863
66.00	-.367
67.00	.308
68.00	.792
70.00	1.442
72.00	1.846
74.00	2.104
76.00	2.267
78.00	2.346
80.00	2.354
82.00	2.300
84.00	2.183
86.00	2.000

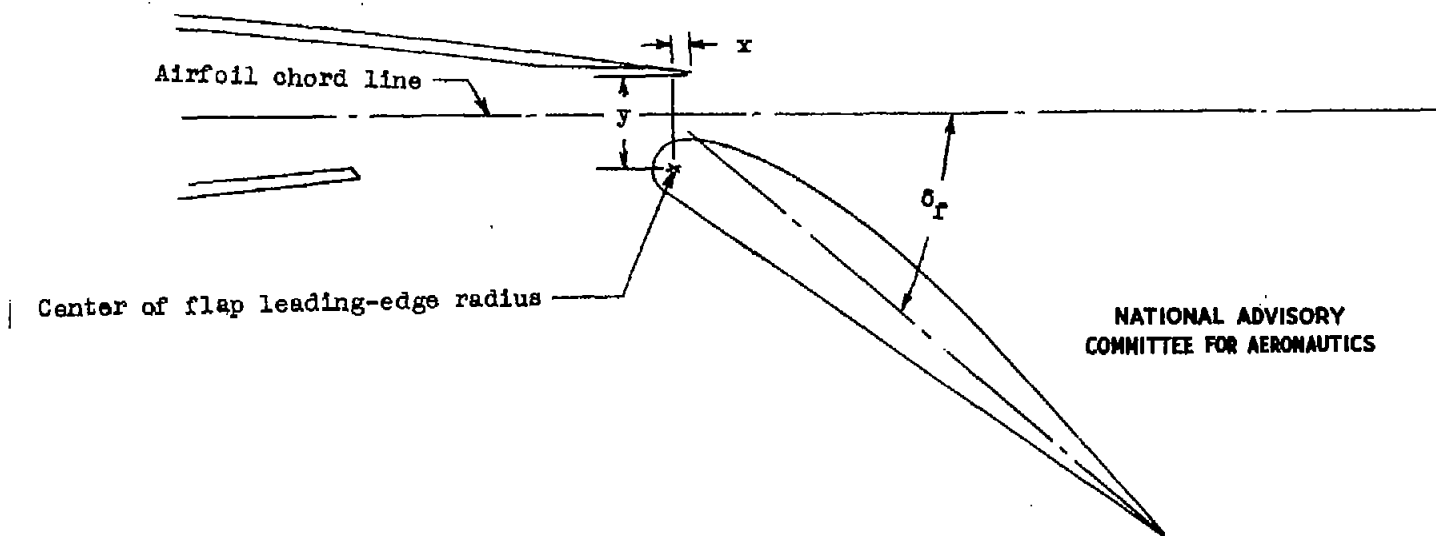
Upper surface fairs into
plain airfoil section
at station 88.00

L.E. radius: 1.404
L.E. radius center at
station 66.50 and
ordinate -1.971

NATIONAL ADVISORY
COMMITTEE FOR AERONAUTICS



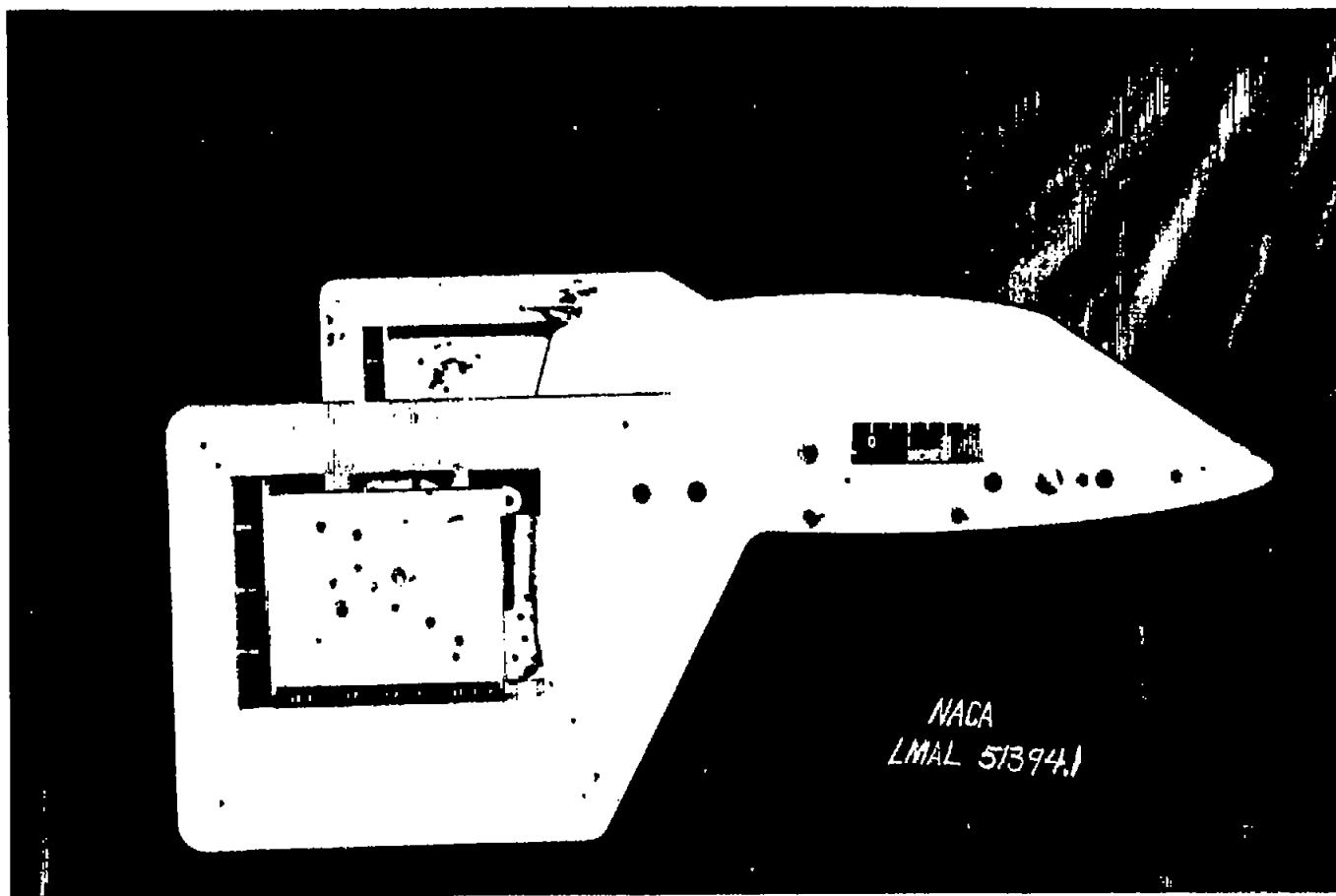
(a) Airfoil with 0.35c slotted flap.



NATIONAL ADVISORY
COMMITTEE FOR AERONAUTICS

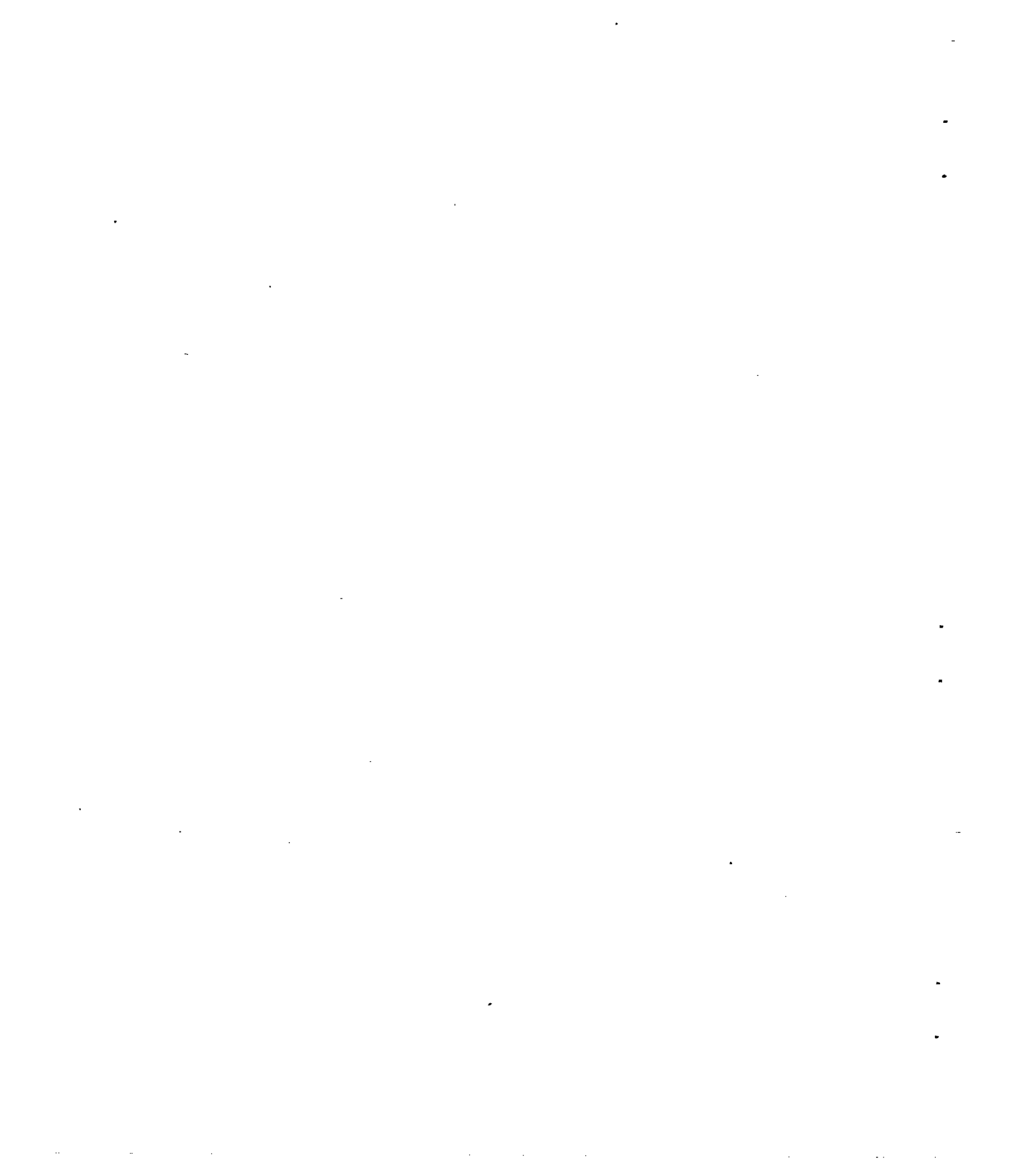
(b) Variables used to define flap configuration.

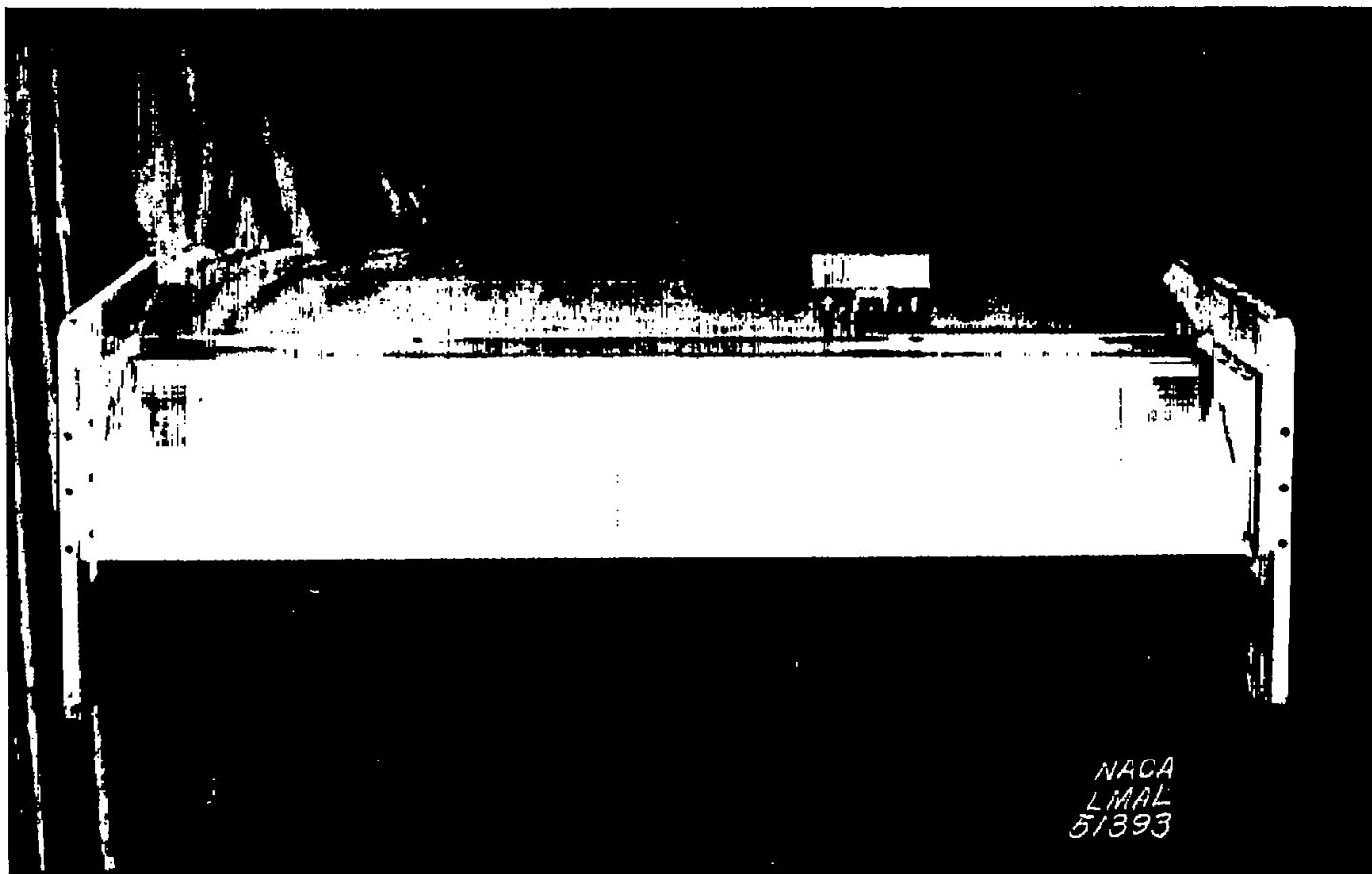
Figure 1.- Profile of the NACA 65(112)A111 (approx.) airfoil section with a 0.35c slotted flap.



(a) Side view.

Figure 2.- Photographs of model with 0.35c slotted flap.

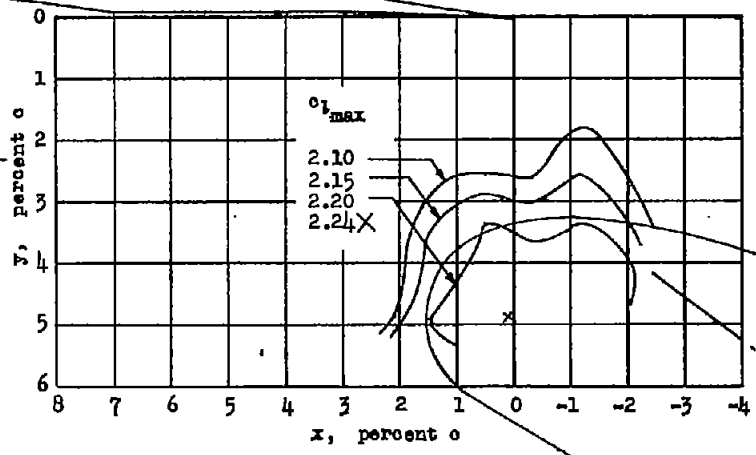




(b) Rear view.

Figure 2.- Concluded.

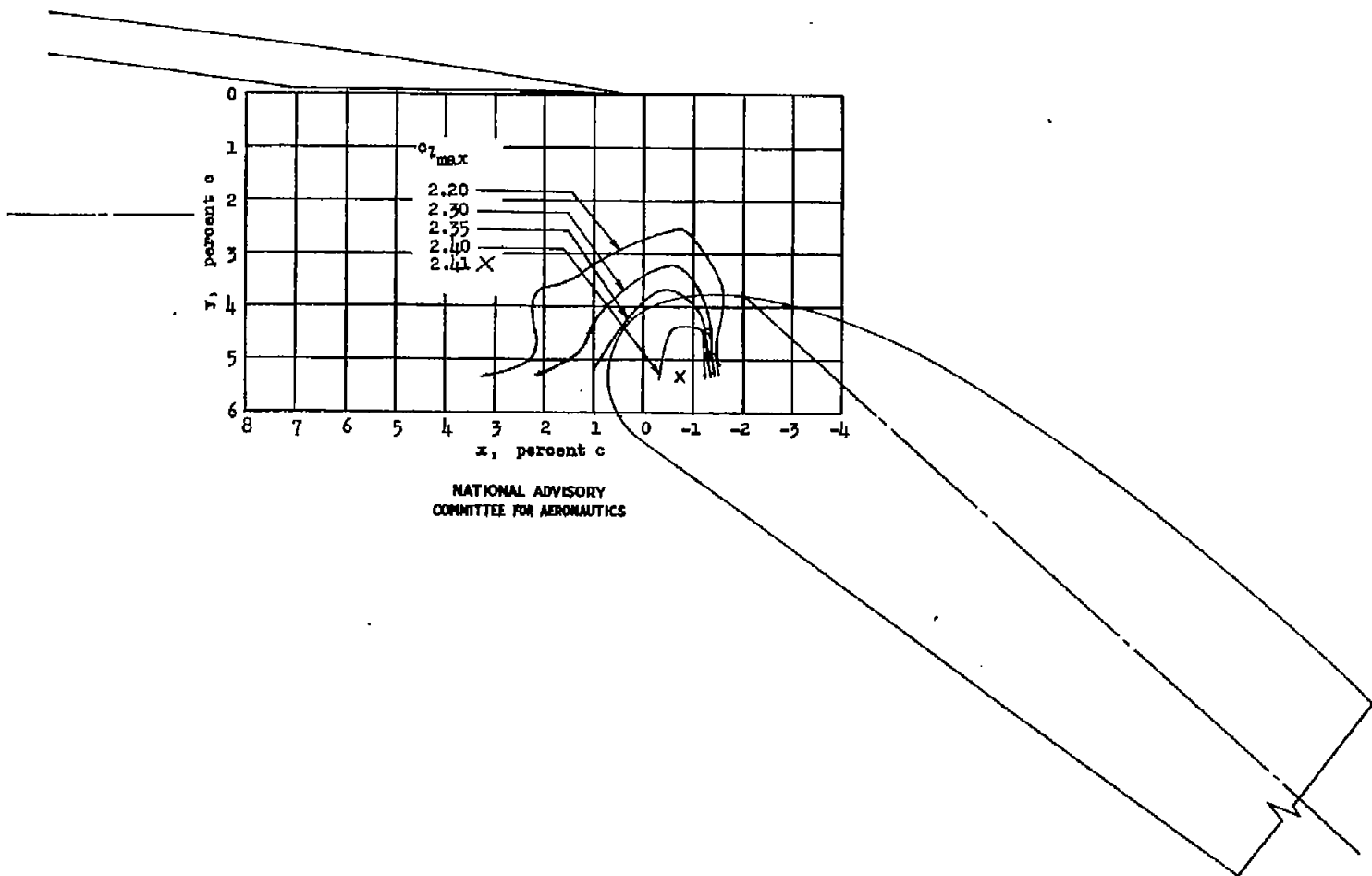




NATIONAL ADVISORY
COMMITTEE FOR AERONAUTICS

(a) $\delta_f = 35^\circ$.

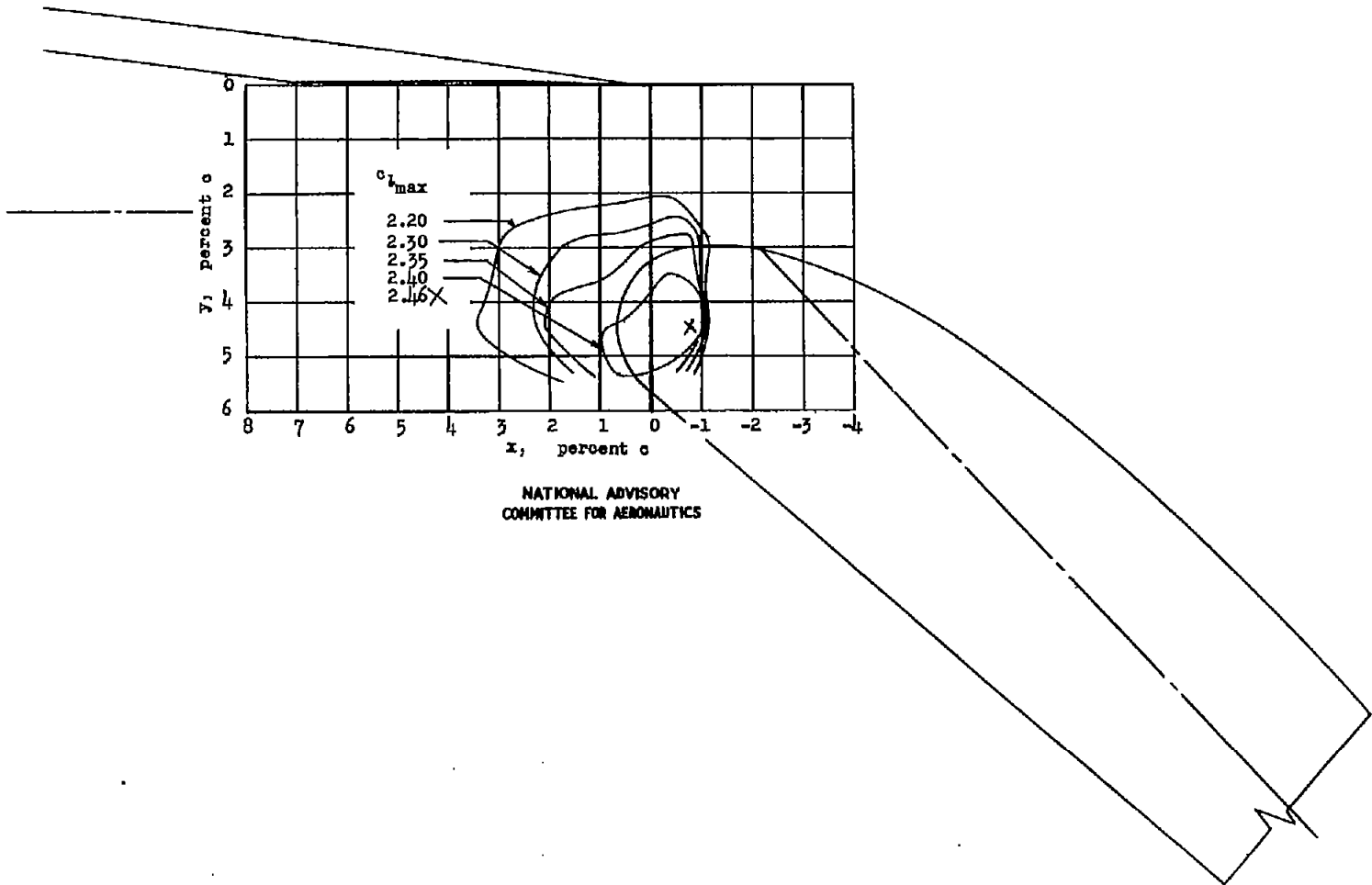
Figure 3.- Contours of values of maximum section lift coefficient for positions of the center of the flap leading-edge radius with respect to slot lip for NACA 65(112)All1 (approx.) airfoil with a 0.35c slotted flap. $R = 2.4 \times 10^6$ (approx.).



NATIONAL ADVISORY
COMMITTEE FOR AERONAUTICS

(b) $\delta_T = 40^\circ$.

Figure 3.- Continued.



(a) $\delta_f = 45^\circ$.

Figure 3.- Concluded.

δ_f (deg)	x (percent c)	y (percent c)	
○	35	0.10	4.87
□	40	-.73	5.29
△	45	-.73	4.46
◇	40	-.32	4.46

} Ideal flap positions

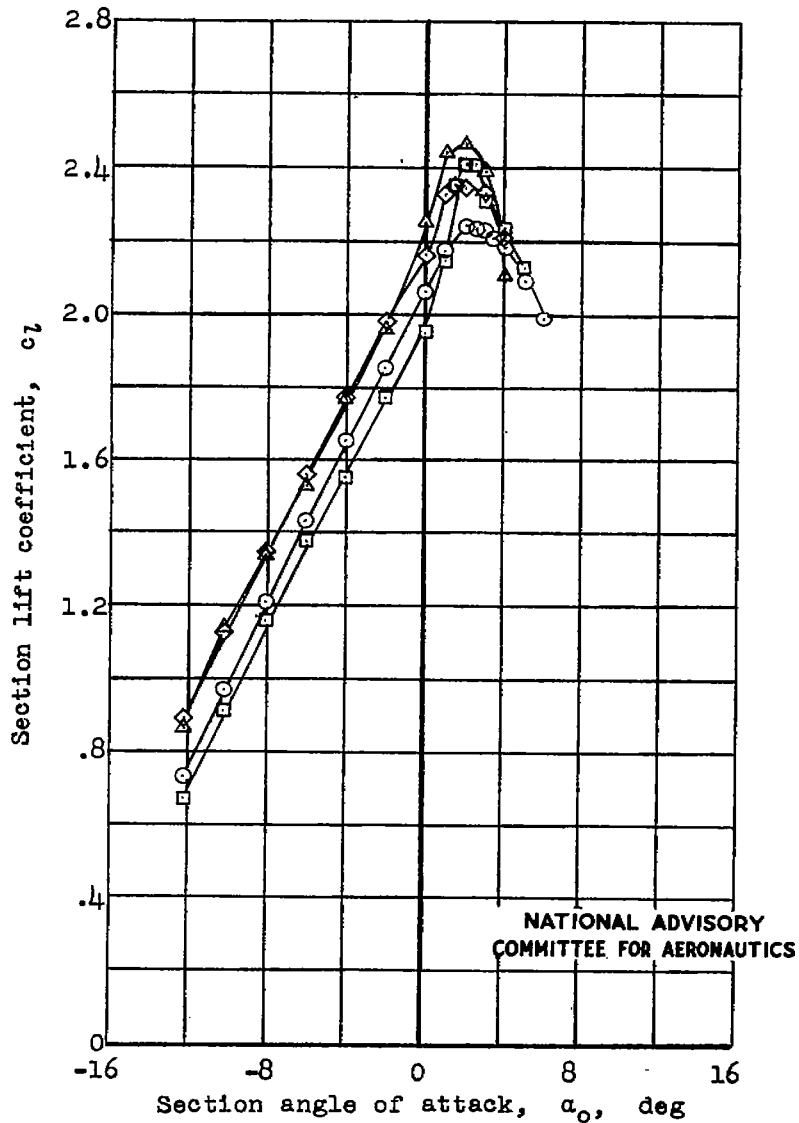
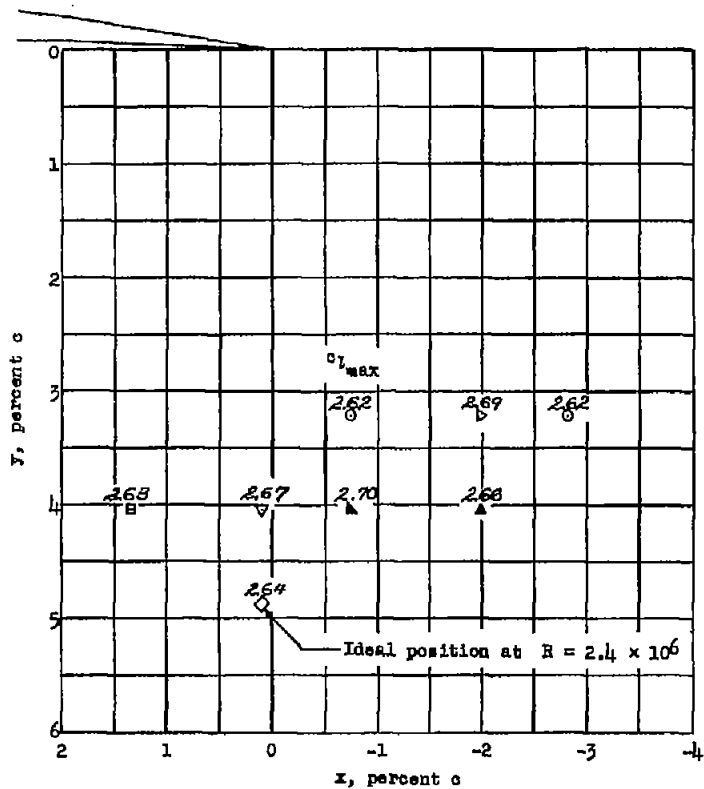
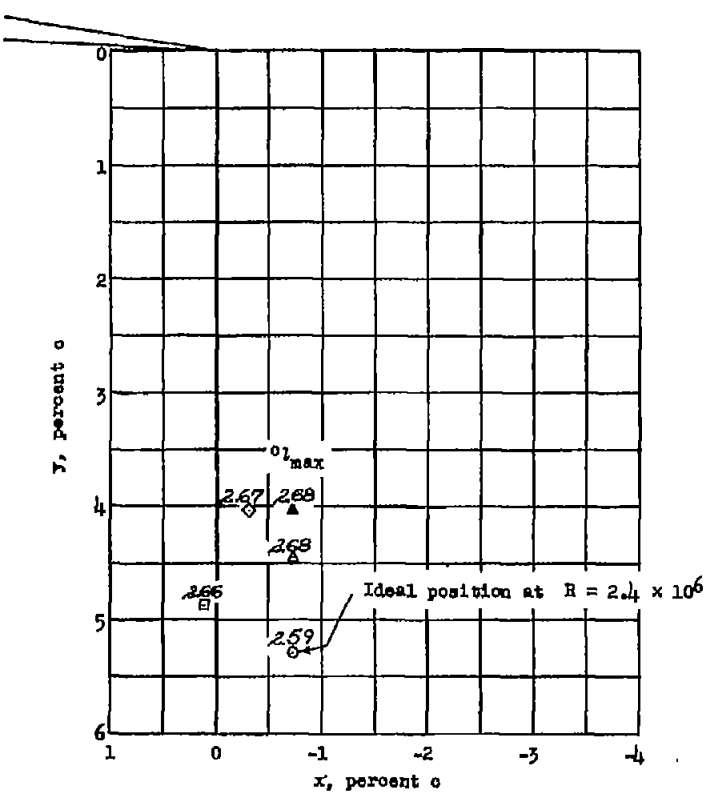


Figure 4.- Section lift characteristics of the NACA 65(112)A111 (approx.) airfoil section with a 0.35c slotted flap. $R = 2.4 \times 10^6$.



(a) $\delta_f = 35^\circ$.



(b) $\delta_f = 40^\circ$.

Figure 5.- Values of maximum section lift coefficient for various positions of the center of the flap leading-edge radius with respect to slot lip of the NACA 65(112) All (approx.) airfoil section with a 0.35% slotted flap. $R = 9.0 \times 10^5$ (approx.).

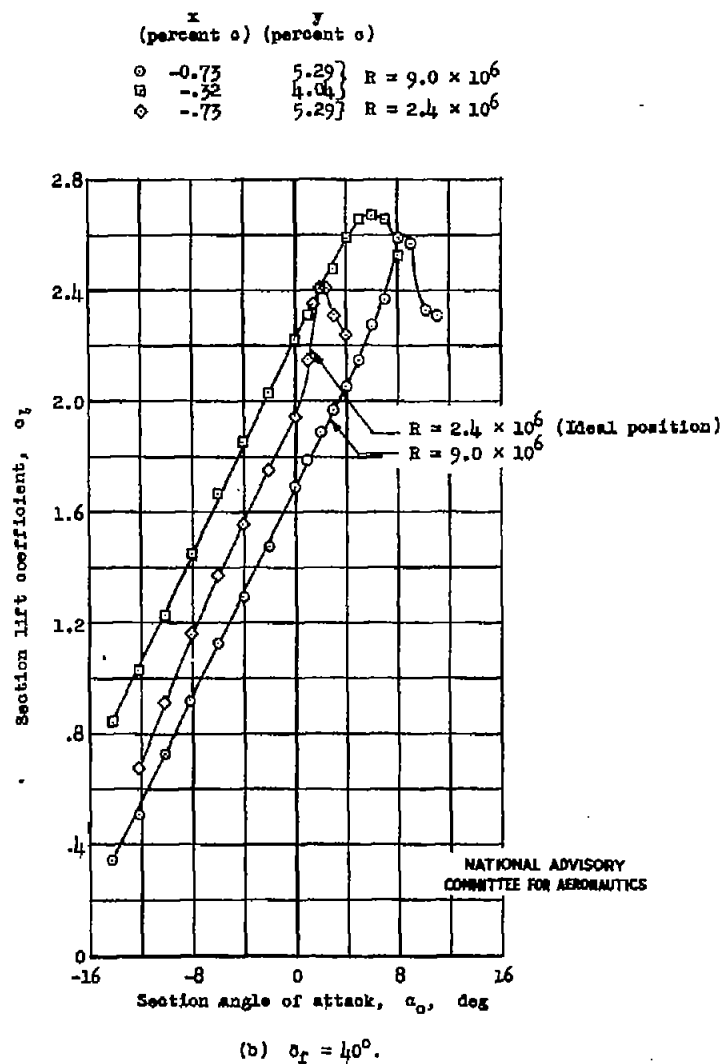
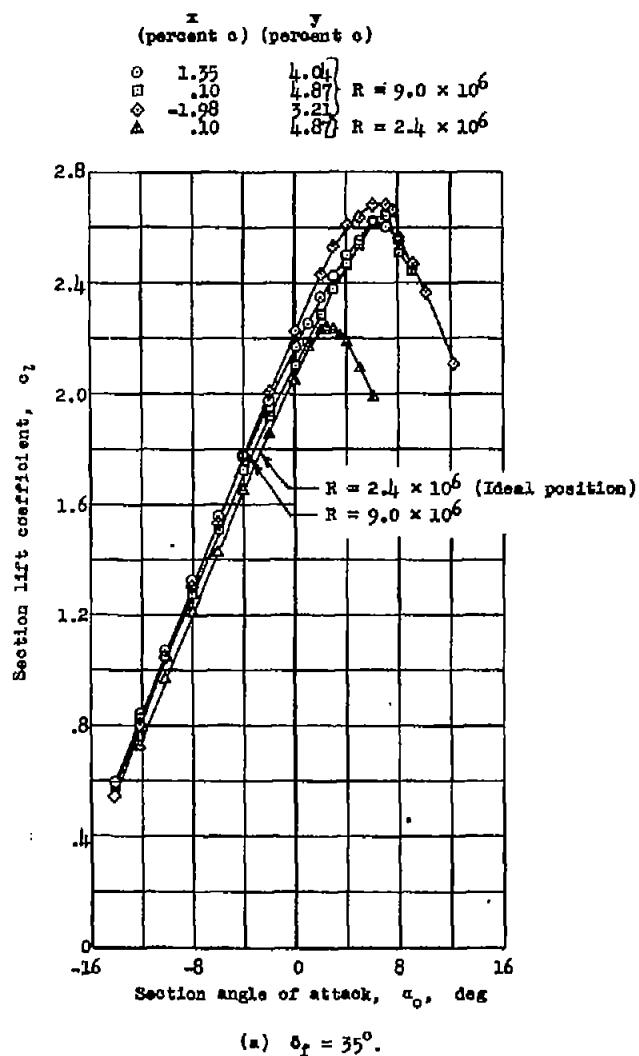


Figure 6.- Variation of section lift coefficient with section angle of attack for several positions of the center of the flap leading-edge radius with respect to slot lip of the NACA 65(112)All (approx.) airfoil section with a 0.35c slotted flap. $R = 9.0 \times 10^6$ (approx.) and 2.4×10^6 .

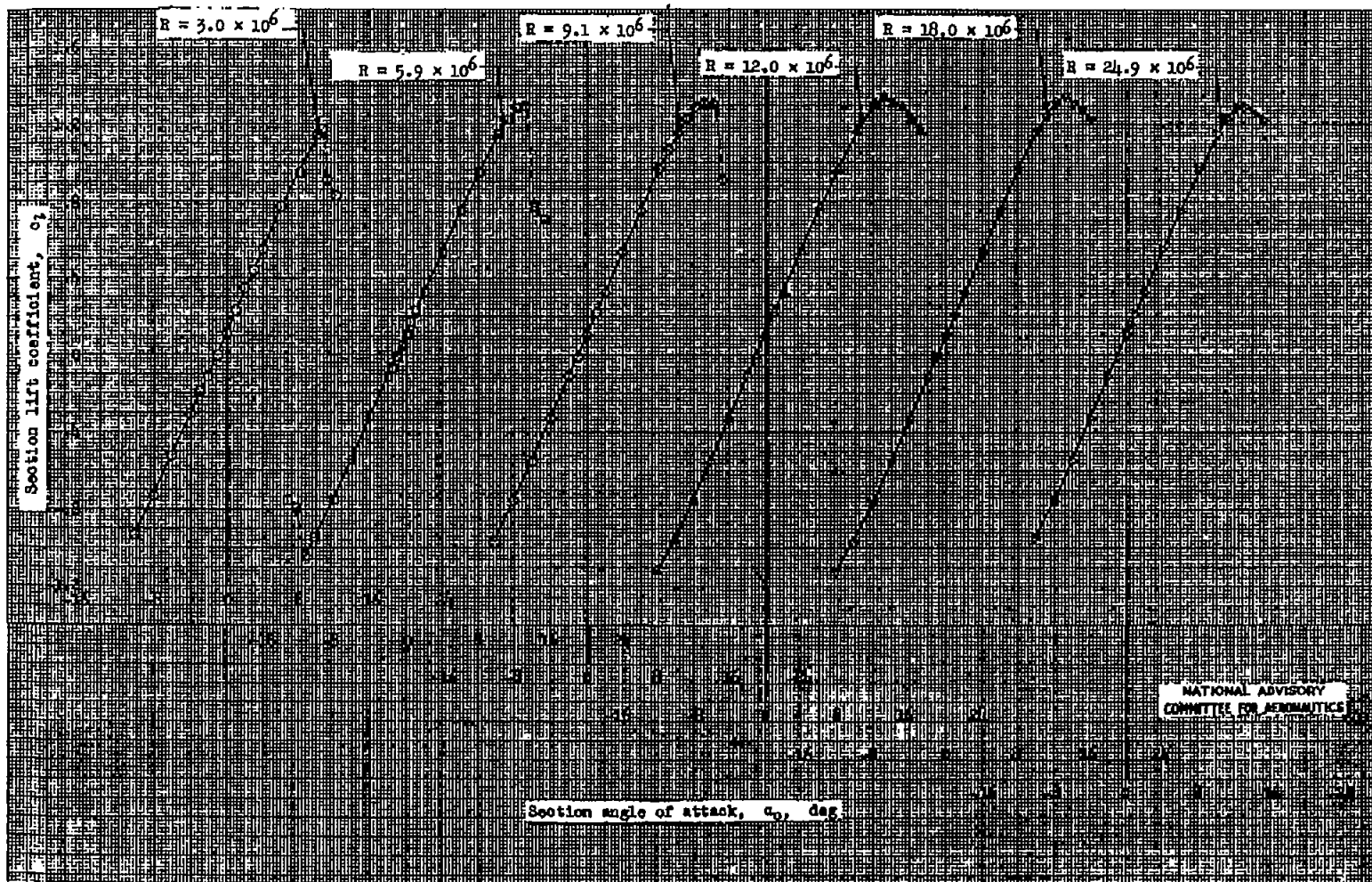


Figure 7.- Section lift characteristics of the NACA 65₍₁₁₂₎All (approx.) airfoil section with flap retracted and slot sealed for several Reynolds numbers.

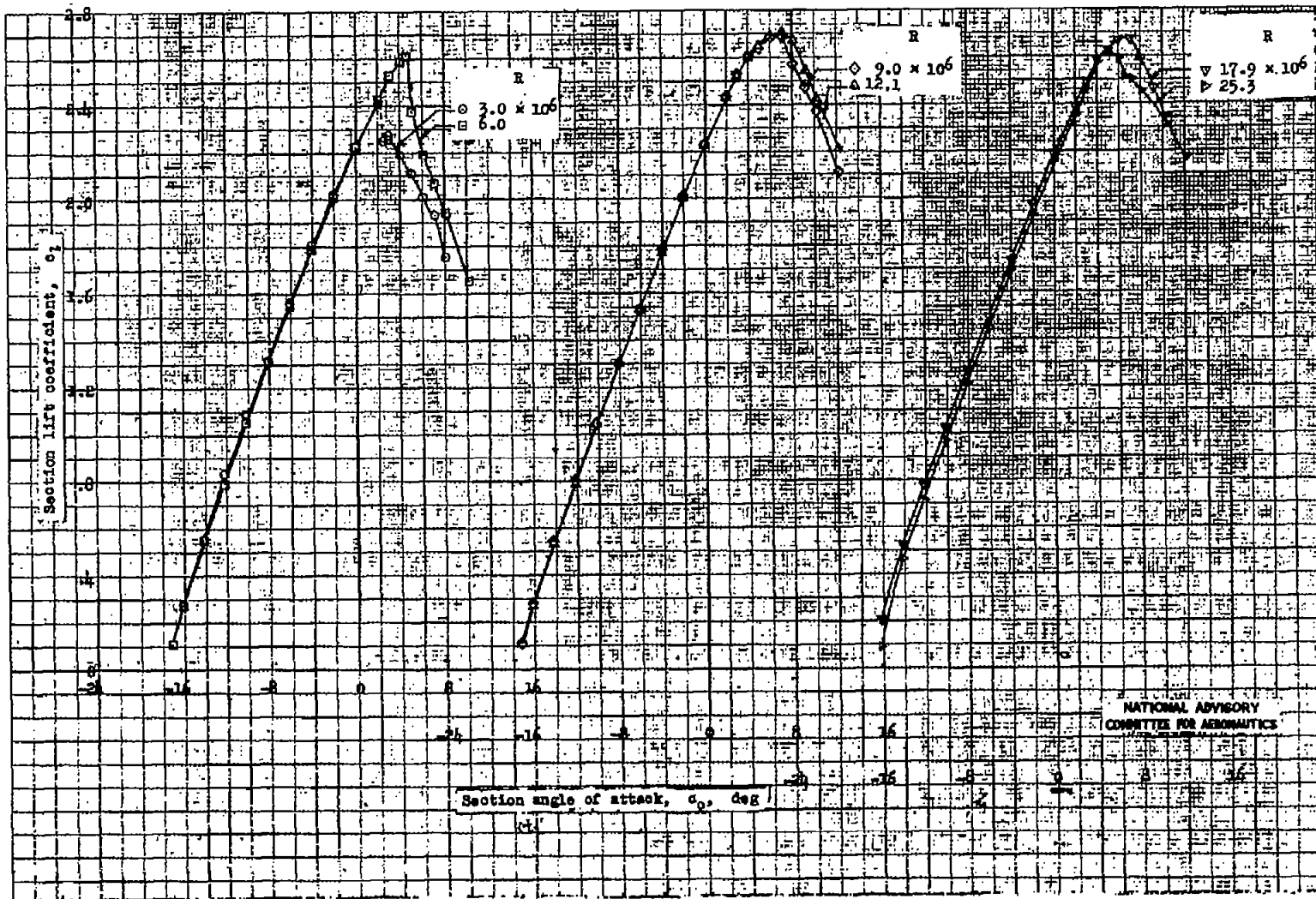


Figure 8.- Section lift characteristics of the NACA 65₍₁₁₂₎ All (approx.) airfoil section with a 0.35c slotted flap at several Reynolds numbers. $\delta_f = 35^\circ$; $x = -1.98$ percent c ; $y = 3.21$ percent c .

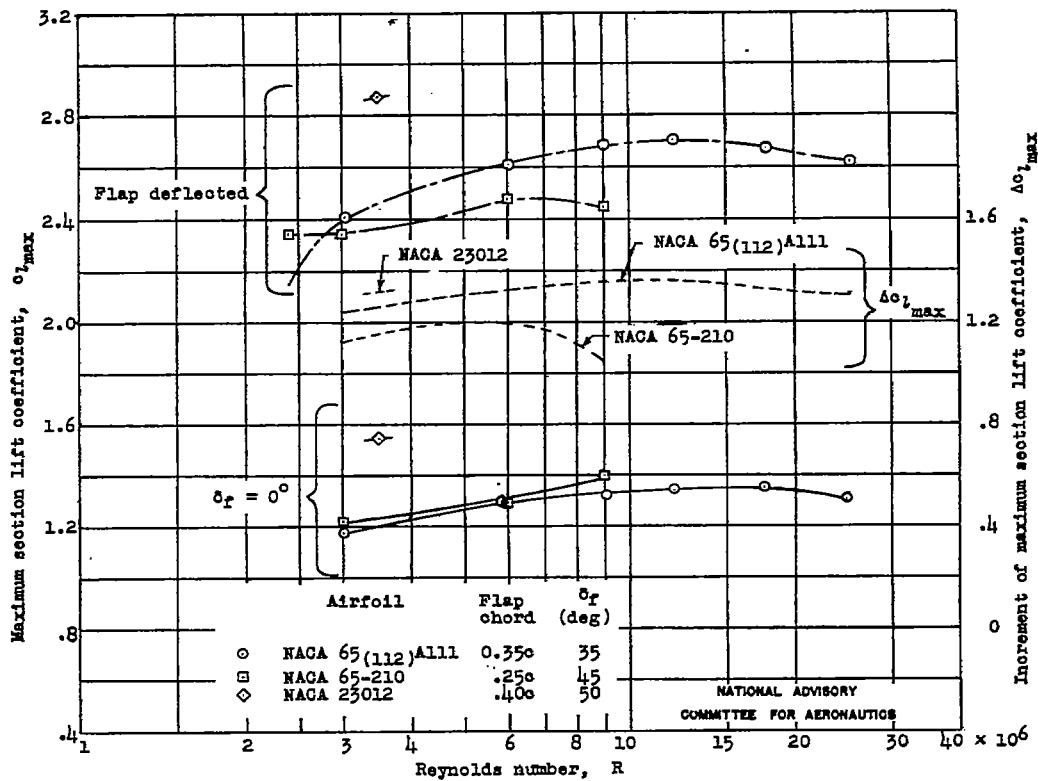


Figure 9.- Variation of maximum section lift coefficient and increment of maximum section lift coefficient with Reynolds number for the NACA 65(112)A111 (approx.) airfoil section with a 0.35c slotted flap.

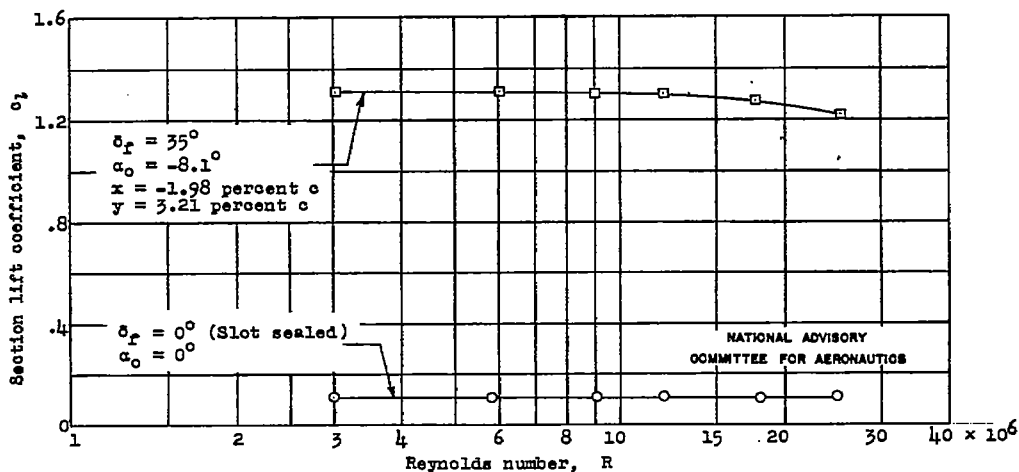


Figure 10.- Variation of section lift coefficient with Reynolds number for the NACA 65(112)A111 (approx.) airfoil section with a 0.35c slotted flap.

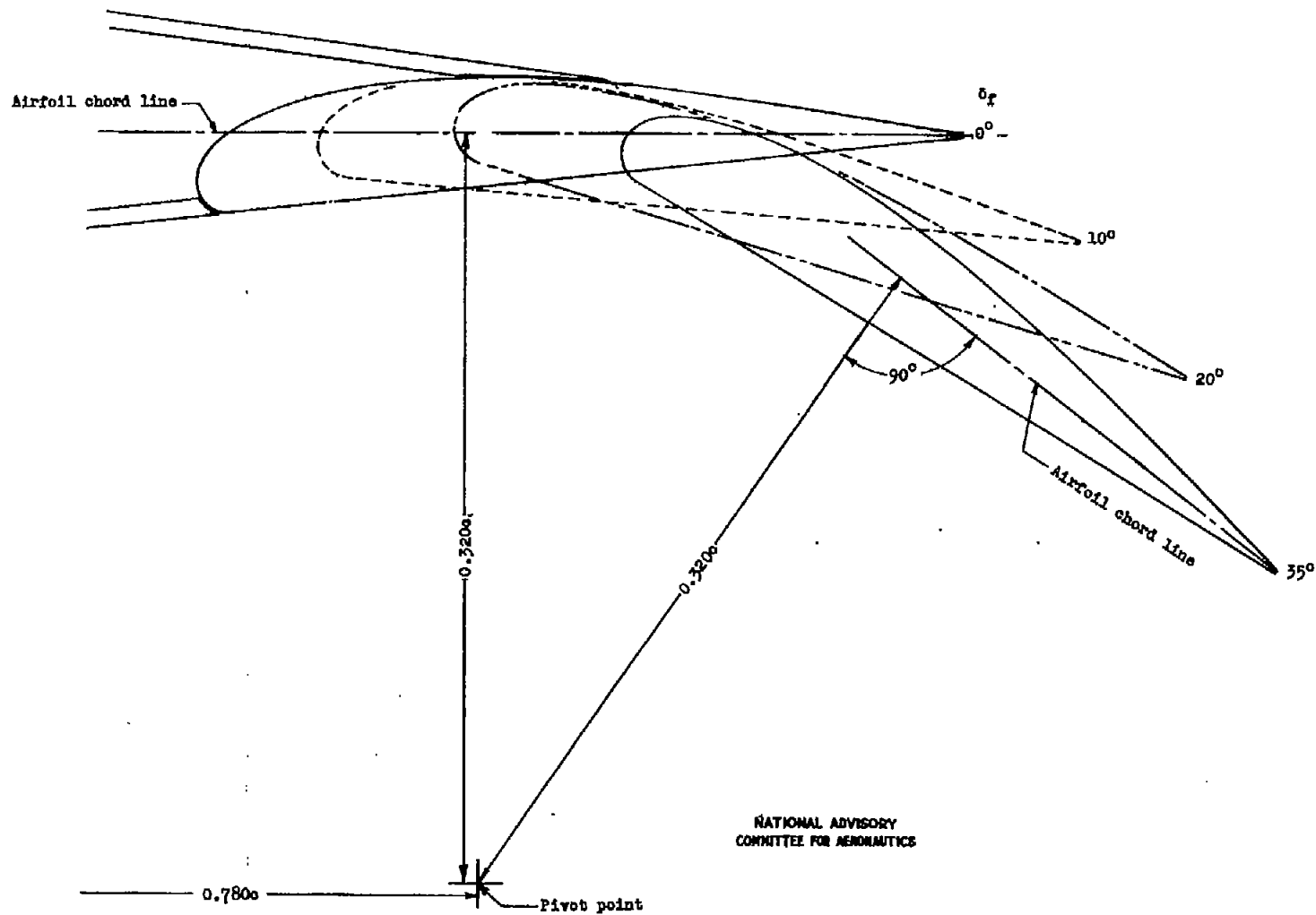


Figure 11.- Slotted flap configurations for intermediate flap deflections. Perpendicular distance from station 0.780c on airfoil chord line to pivot point is 0.520c for all flap deflections.

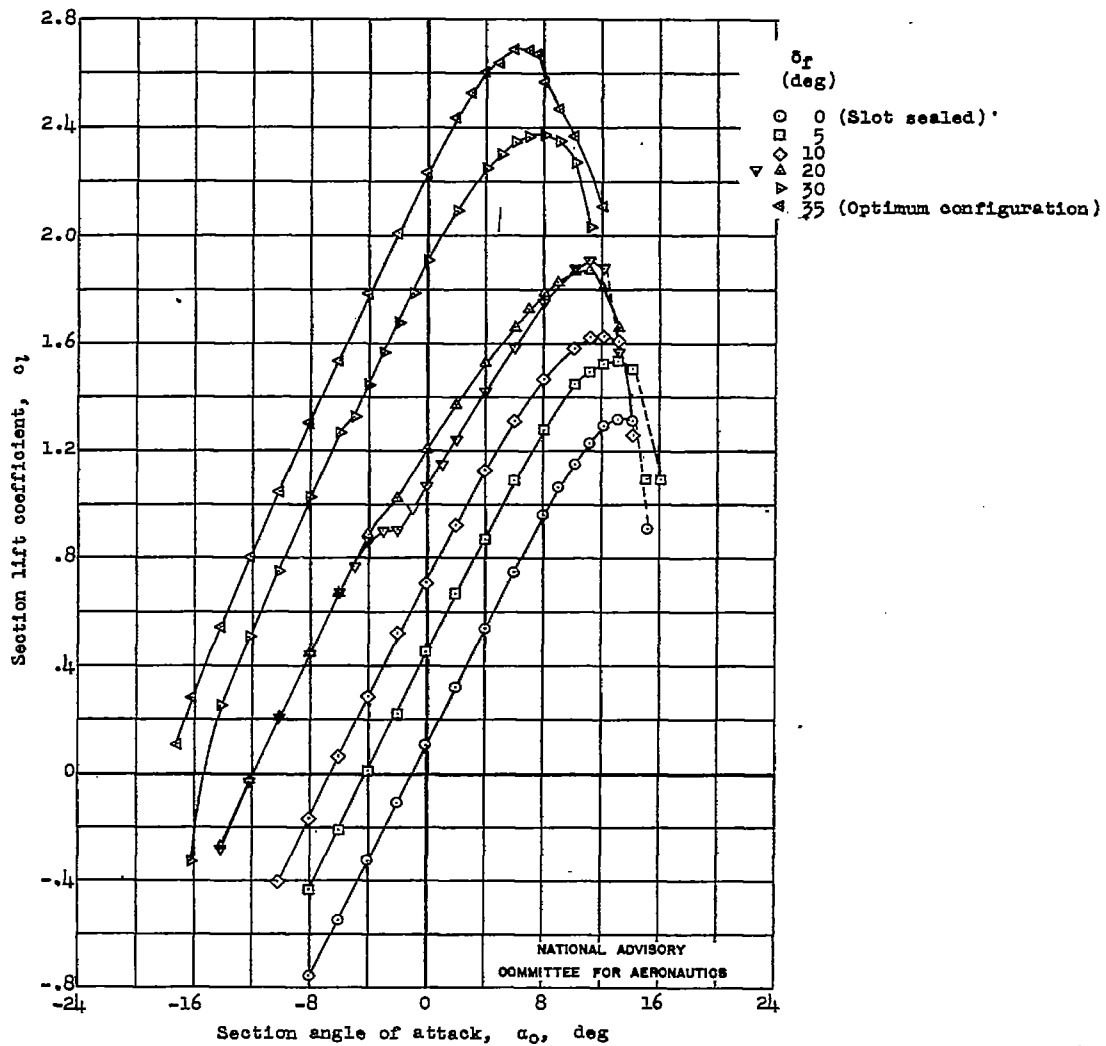


Figure 12.- Section lift characteristics of the NACA 65(112)A111 (approx.) airfoil section at several flap deflections with the 0.35c slotted flap following a circular-arc path. $R = 9.0 \times 10^6$.

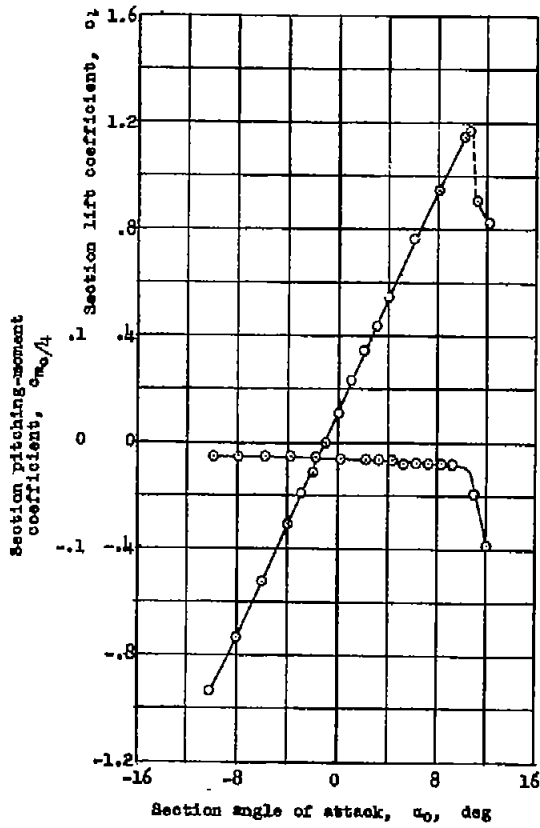
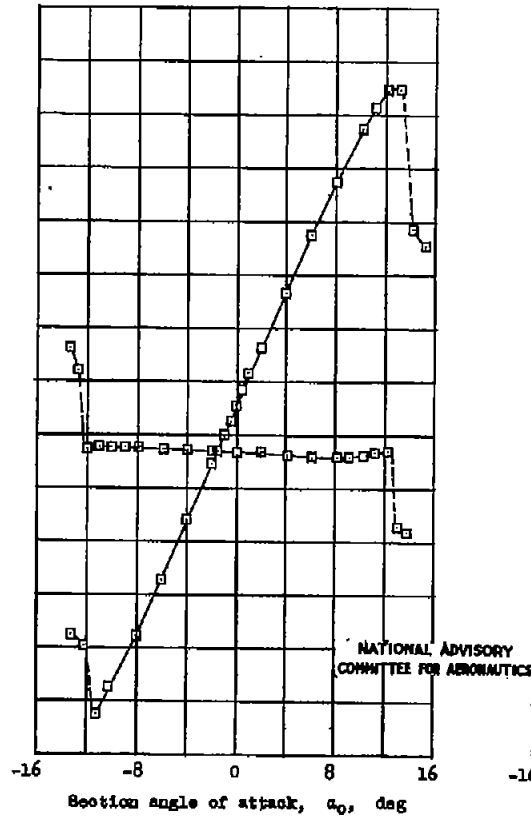
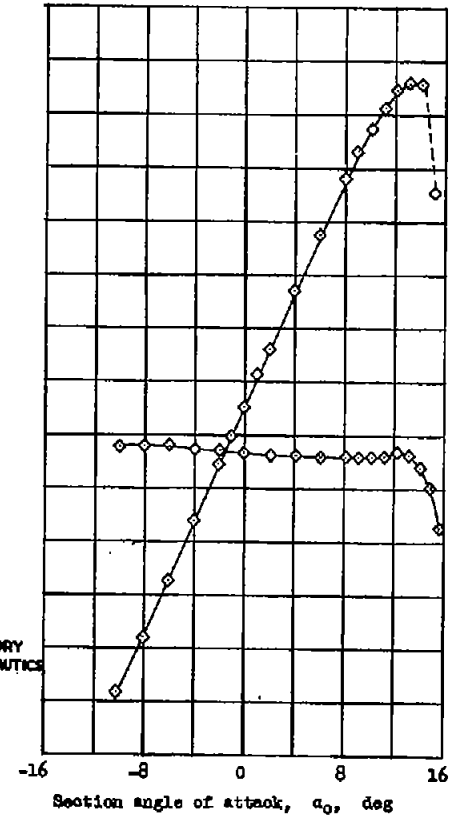
(a) $R = 3.0 \times 10^6$.(b) $R = 5.9 \times 10^6$.(c) $R = 9.1 \times 10^6$.

Figure 13.- Section lift and pitching-moment characteristics of the NACA 65(112) All (approx.) airfoil section with flap retracted and slot sealed.

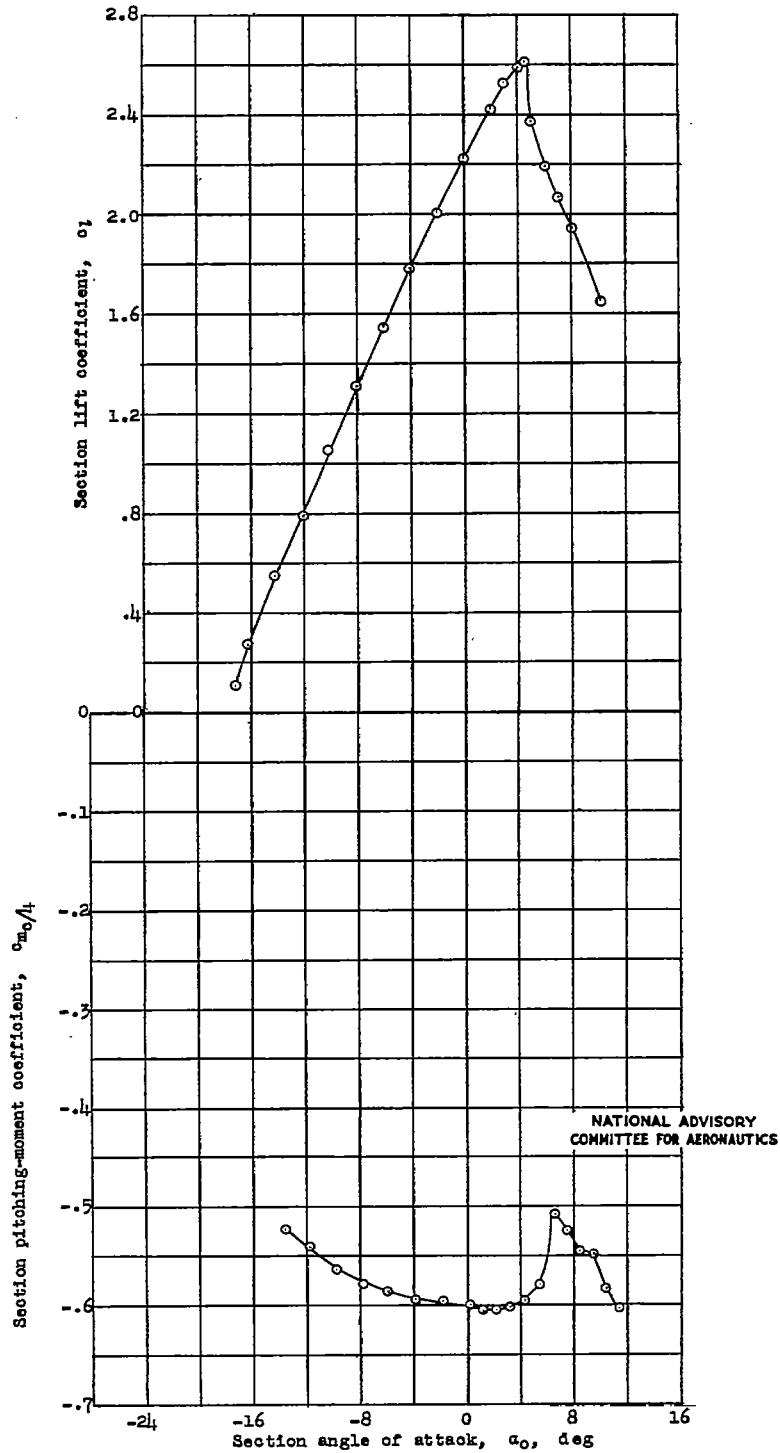


Figure 14.- Section lift and pitching-moment characteristics of the NACA 65(112) all (approx.) airfoil section with a 0.35c slotted flap. $\delta_f = 35^\circ$; $x = -1.98$ percent c ; $y = 3.21$ percent c ; $R = 6.0 \times 10^6$.

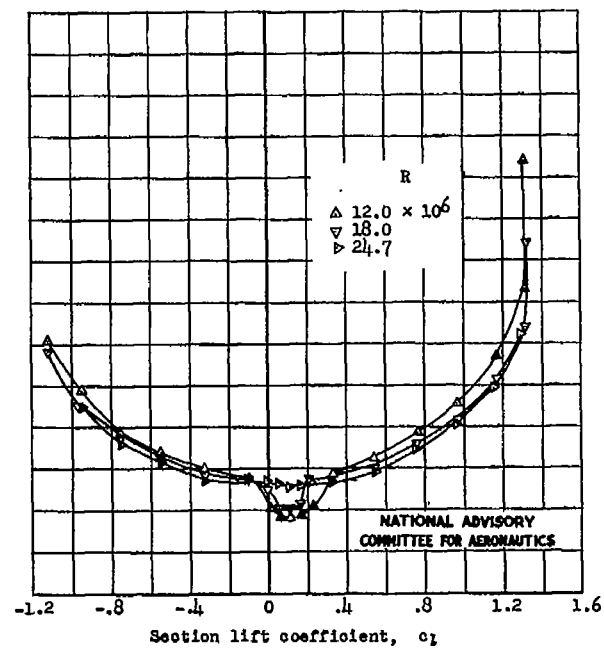
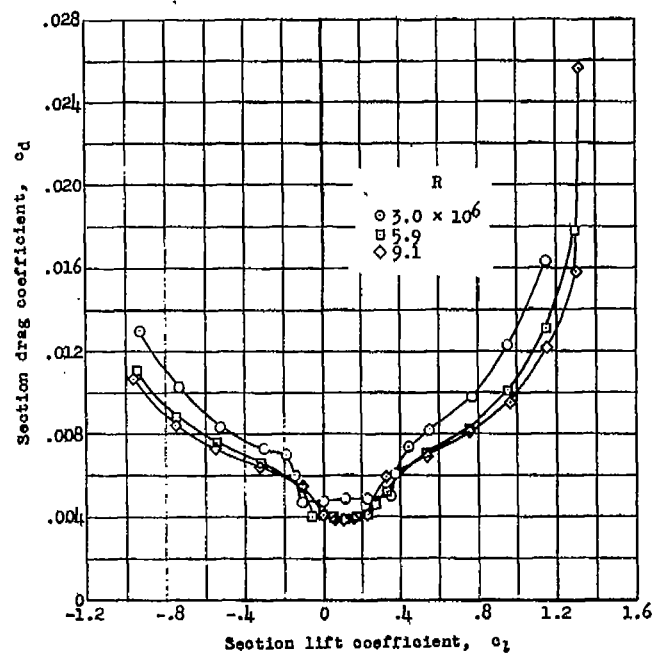
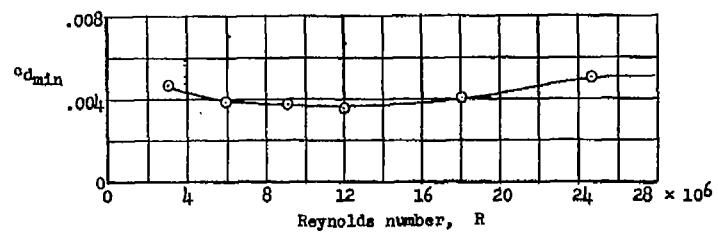
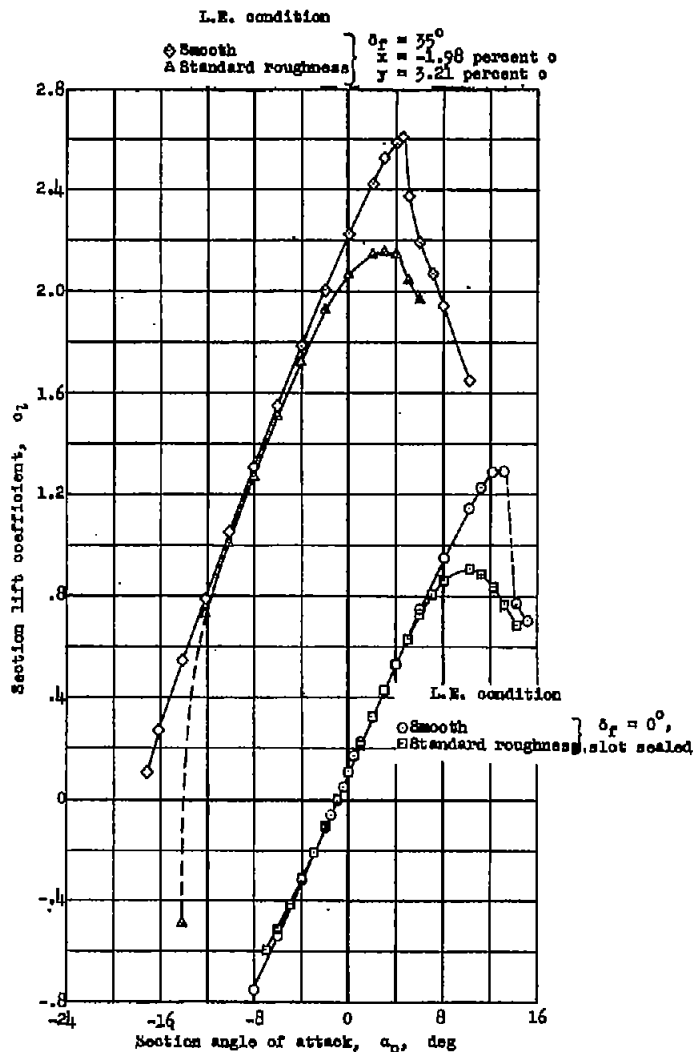
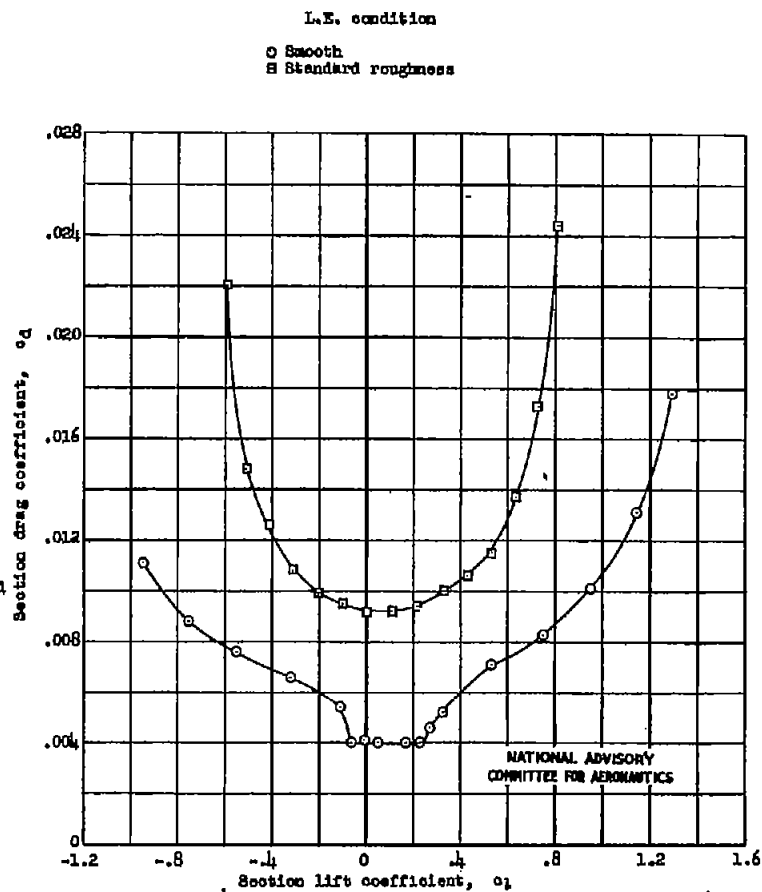


Figure 15.- Section drag characteristics of the NACA 65₍₁₁₂₎A111 (approx.) airfoil section with flap retracted and slot sealed.



(a) Lift characteristics.



(b) Drag characteristics, $\delta_F = 0^\circ$, slot sealed.

Figure 16.- Section lift and drag characteristics of the NACA 65(112)All1 (approx.) airfoil section with a 0.3% slotted flap for smooth condition and condition with standard leading-edge roughness. $R = 6.0 \times 10^6$.

need for compliance with security regulations pertaining to classified

TITLE: Investigation of NACA 65⁽¹¹²⁾ A111 (Approx.) Airfoil with 0.35-Chord Slotted Flap at Reynolds Numbers up to 25 Million

AUTHOR(S): Racisz, Stanley F.

ORIGINATING AGENCY: Langley Memorial Aeronautical Lab., Langley Field, Va.

PUBLISHED BY: National Advisory Committee for Aeronautics, Washington, D. C.

ATI- 34110

REVISION
(None)

ORIG. AGENCY NO.

TN-1463

PUBLISHING AGENCY NO.
(Same)

DATE	DOC. CLASS.	COUNTRY	LANGUAGE	PAGES	ILLUSTRATIONS
Oct '47	Unclass.	U.S.	Eng.	31	photos, tables, graphs, drwgs

ABSTRACT:

Wind-tunnel investigation of the NACA 65⁽¹¹²⁾A111 airfoil with 0.35-chord slotted flap was made at Reynolds Numbers ranging from 2.4×10^6 to 25.0×10^6 . Results indicated that for this airfoil and flap, the flap deflection for highest maximum section lift coefficient decreased, and the flap position for highest c_{max} moved rearward and upward as Reynolds Number increased from 2.4×10^6 to 9.0×10^6 . Maximum lift coefficient for this airfoil with flap retracted and with flap deflected generally increased with Reynolds Number up to about 15.0×10^6 and then decreased slightly.

DISTRIBUTION: Request copies of th' report only from Publishing Agency

DIVISION: Aerodynamics (2)

SECTION: Wings and Airfoils (6)

SUBJECT HEADINGS: Airfoils - Aerodynamics (07710);
Flaps - Effect on wing characteristics (37451.1); Wings -
Reynolds Number effect (99176.5)

ATI SHEET NO.: R-2-6-77

Air Documents Division, Intelligence Department
Air Materiel Command

AIR TECHNICAL INDEX

Wright-Patterson Air Force Base
Dayton, Ohio

DECEMBER 1948

RF 5