

AD A950017



Japan
①
⑫ 708

⑥ JAPANESE STUDIES ON MANCHURIA
Volume V
INFANTRY OPERATIONS

⑪ 14 Dec 56

US ARMY INFANTRY HUMAN RESEARCH UNIT
P. O. Box 2086
Fort Benning, Georgia
PREPARED BY
HEADQUARTERS, USAFFE
AND EIGHTH U.S. ARMY (REAR)

DTIC
SELECTED
AUG 27 1980
S C

DISTRIBUTED BY
OFFICE OF THE CHIEF OF MILITARY HISTORY
DEPARTMENT OF THE ARMY

This document has been approved
for public release and sale; its
distribution is unlimited

DDC FILE COPY

Jan

038250

EDITOR'S PREFACE

Volume V of the Japanese Studies on Manchuria surveys infantry operations: organization, equipment, training, tactics, and logistics. The original manuscript was prepared by former-Major General Matsushiro Ugaki, an infantry expert who had long experience in Manchuria as well as at the Chiba Infantry School. The end of World War II found General Ugaki serving as Deputy Chief of Staff, Formosa Army.

Data contained in the original manuscript were uneven in quality and emphasis, and were accompanied by incompleteness and gaps. Throughout the study the editor has attempted to retain the literary flavor of the Japanese author, within a more coherent and understandable whole. Subjective value judgments are retained from the original, since the entire present series are Japanese studies under American historical editorship. Footnotes and documentation have been provided, where necessary, to explain, amplify, or correct statements made in the text.

Former-Colonel Muraji Iano, now senior consultant to the Japanese Research Division, has provided valuable assistance throughout the editing of this study.

14 December 1956

Accession For	
NTIS GRA&I	
DDC TAB	
Unannounced	
Justification <i>Per [initials]</i>	
BY <i>[signature]</i>	
Distribution/	
Availability Codes	
Dist	Availand/or special
A	

UNANNOUNCED

Japanese Studies on Manchuria

Volume V

TABLE OF CONTENTS

<u>Chapter</u>	<u>Page</u>
Editor's Preface	3
I. Organization and Equipment.	11
Introduction	11
Individual Equipment	12
Infantry Company	14
Antitank Defense.	17
Armament	19
Rifle	19
Light Machine Gun	19
Grenade Discharger.	20
Personnel Strength.	21
Infantry Battalion	25
Antitank Weapons.	26
Liaison and Supply.	29
Heavy Machine Gun Company	29
Battalion Gun Company.	30
Army Dogs	31
Chemical Warfare.	31

<u>Chapter</u>	<u>Page</u>
1. Organization and Equipment (contd.)	
Infantry Regiment	35
Regimental Gun Units	35
Signal Company	36
Infantry Engineers	39
Infantry Brigade and Infantry Group	41
Fundamentals.	45
2. Tactics.	47
General	47
Combat Frontages and Depths	49
Attack Operations	52
Antitank Tactics	54
Antiaircraft Operations.	54
Gas and Smoke.	55
Attacks on Positions	55
Combat Approach.	56
Dawn or Night Attacks.	57
Combined Operations.	57
Night Attacks.	58
Fire Discipline at Night	60
Dawn Attacks	62
Dawn Attacks by Combined Arms.	64
Dusk Attacks	66

<u>Chapter</u>	<u>Page</u>
2. Tactics (contd.)	
Defensive Operations.	67
Field Positions.	67
Zones of Resistance.	67
Fire Network.	68
Observations	69
Border Defenses.	69
Forest Fighting	71
Swamp Fighting.	73
Winter Fighting	74
Special Considerations	75
3. Training and Materiel.	77
Psychological Factors	78
Combat Training	81
Firing Techniques	84
Materiel.	85
Rifle.	86
Pistol	87
Light Machine Gun.	87
Grenade Discharger	87
Heavy Machine Gun.	88
Antitank Defense	88

<u>Chapter</u>	<u>Page</u>
3. Materiel (contd.)	
Regimental Gun	89
Armored Tractors	89
4. Fortifications and Logistics	91
Fortifications.	91
Fundamentals	91
Offensive Fortifications	92
Defensive Fortifications	92
Developments	93
Logistics	95
Ammunition Supply.	95
Rear Supply.	98
Rations and Forage	99
Ordnance	100

Appendices

A. Japanese Army Defensive Concepts.	103
B. <u>Field Service Code</u> (<u>Senjinkun</u>)	107
 Index	 121

TABLES, FIGURES, AND PHOTOGRAPHS

TABLES

<u>No.</u>	<u>Title</u>	<u>Page</u>
1.	Standard Infantry Combat Frontages and Depths.	51
2.	Ammunition Loads.	97
3.	Allocations of Provisions.	101

FIGURES

<u>No.</u>	<u>Title</u>	<u>Page</u>
1.	Rifle Company (Standard)	15
2.	Rifle Company (Reinforced)	23
3.	Infantry Battalion (Standard).	27
4.	Infantry Regiment (Standard)	37
5.	Infantry Division (Square Type).	43
6.	Infantry Division (Triangular Type).	43

PHOTOGRAPHS

<u>No.</u>	<u>Caption</u>	<u>Page</u>
1.	Presentation of Imperial Colors to 1st Infantry Regiment, Guard Division, Hibiya Parade Ground, 23 January 1874	33
2.	"Emperor Meiji was pleased to conduct personal inspection of clan soldiers in training." Etchujima Parade Ground, 8 September 1870	79

CHAPTER 1
ORGANIZATION AND EQUIPMENT

Introduction

The focus of attention in a discussion of Japanese Army infantry problems should be the combat unit, rather than garrison, special, or depot units. Employed primarily in field operations, the combatant unit constituted the bulk of the Army's strength and the basic element of the individual field armies.

The organization and equipment of combatant units underwent constant study and a certain amount of improvement following World War I. Weapons and tactics, in particular, were modified and developed. Nevertheless there were many obstacles to progress, and the China Incident of 1937 broke out in the midst of reorganization. Four years later came the Pacific War. On the whole, infantry organization and equipment remained in an extremely unsatisfactory status.

With the deterioration of the war situation in 1944 and 1945, not only were military preparations delayed in Manchuria, but weapons, supplies, and troops were pulled out of the Kwantung Army, or diverted before assignment to that army. Under the circumstances, an improvement in weapons was out of the question.

PRECEDING PAGE BLANK-NOT FILMED

Until the outbreak of the Pacific War, Japanese manpower had been sufficient to meet the requirements of the then-anticipated operations against the Soviet Union, but weapons and supplies (especially ammunition for new weapons) were limited. As a consequence, there arose tactical concepts which cheapened human life and valued horses and weapons more than men. After World War II, this notion of making up for shortages of weapons and of ammunition with human lives was bitterly criticized in Japan. It is undeniable that "human bullet," suicide concepts proved to be a fatal error for the Japanese Army, particularly where infantry tactics were concerned.

In devising countermeasures for dealing with improved aircraft and mechanized units (especially armor), the Japanese Army failed to achieve satisfactory results; it lacked experience and could not keep up with the rapid progress of new technology. Concerning communications and signal equipment, constant research and experimentation were undertaken in order to remain abreast of scientific advances. Few user units, however, were actually supplied with the latest communication equipment developed in the laboratories.

Individual Equipment

Since a soldier possesses only limited carrying capacity, the Japanese Army restricted the individual's load to approximately 30

kilograms (66.14 pounds), including minimum amounts of weapons, tools, supplies, and clothing required in battle. Combat loads somewhat varied with the assignment of the individual, depending upon whether he was a rifleman, light machine-gunner, grenade discharger, crewman or ammunition carrier for a heavy machine gun or an infantry gun, signaller, etc. In the case of soldiers manning infantry guns, machine guns, or grenade dischargers, the gunner is particularly active physically, and his combat load had to be reduced.

Historically speaking, the individual Japanese soldier's combat load increased greatly since the days of the Russo-Japanese War of 1904-05. For example, such items as anti-gas equipment, camouflage materials, and body armor had to be added.

A standard load of 30 kilograms is considered to be excessive. Laden down by such a weight, troops can manage to fight only under the most favorable conditions. Combat loads should be limited to approximately one-third of individual body weight.

1/4

Infantry Company

The company was the smallest infantry element trained and equipped to carry out combat missions independently. The strength of this type of infantry unit was fixed in troop strength, weapons, and supplies, so that the company commander could always exercise personal control.

Within the company, the three-platoon system was adopted in order to facilitate combat and command. For the company commander to handle his force directly, total personnel strength was maintained within a ceiling of 200, a practice in effect since the days of the Russo-Japanese War. Before the Pacific War, company strength was increased to 250 only during the period of wartime organization in 1914. (See Figure 1).

Despite fixity in unit strength, the advent of modern ground and aerial bombardment and the extensive adoption of extended-formation tactics rendered personal command of an infantry company increasingly difficult. Changes inevitably became necessary in the methods of maintaining command over, and liaison between, the individual platoons.

Although radio communication between company commanders and platoon leaders was considered essential, difficulties arose because of equipment shortages and technical difficulties, especially the assignment of frequencies. As a consequence, the Infantry

FIGURE 1

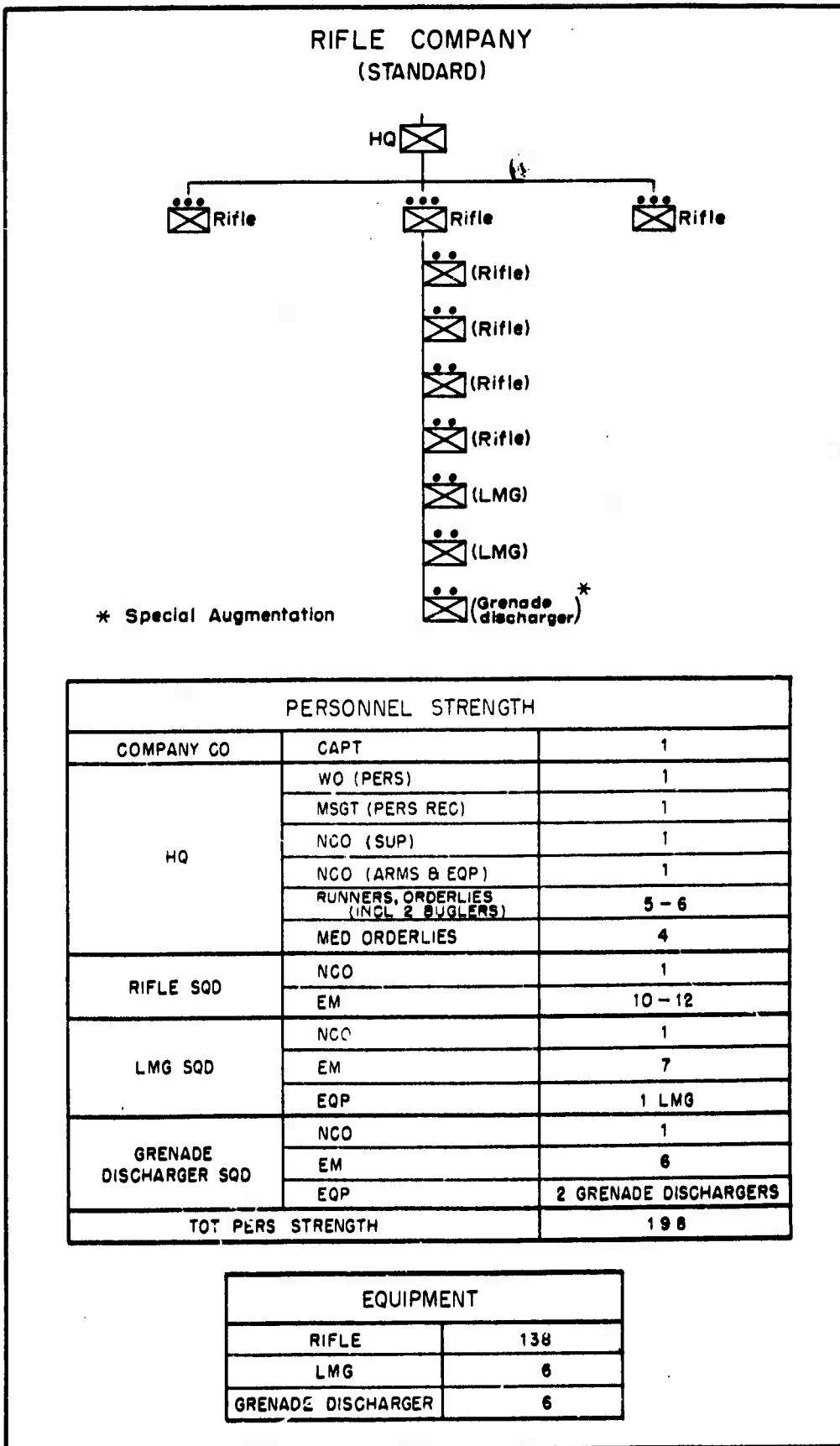

Training Manual was obliged to prescribe the organization of a so-called "command section," led by a warrant officer and made up of headquarters company personnel, serving under the direct control of the company commander. The command section employed various means of communication to effect liaison between the company commander and his platoon leaders; e.g., runners, semaphore flagmen, and messenger-dogs.

Antitank Defense

With the development of modern mechanized forces, it was decided to include light and effective antitank weapons within the tables of equipment of the infantry company. Although in production, these weapons could not be supplied to all user units, but¹ to only a few battalion heavy weapons outfits.

Gas-operated weapons were designed for use against enemy armor, primarily light tanks and armored cars, but weight had to be restricted in order to allow man-portability in combat. Calibers could not therefore exceed 20-mm., and as a result the penetrative power was comparatively low, even at short ranges, against modern armor shielded by more than 6-mm. plate. During the Pacific War, this type of AT weapon became obsolescent; in the future, it should

1. The author is referring to the Model 97 (1937) 20-mm. AT rifle. See following text. - Ed.

be replaced by rocket launchers.

In addition to antitank weapons, the Japanese infantry company was trained in suicidal close-quarter combat tactics. Two- or three-man combat teams were organized within the company. From a stock of about 30 mines per company, one or two mines were supplied each team for use against enemy armor. Closing in upon or ambushing vehicles, the teams were to hurl their mines at vulnerable parts, or plant explosives under treads. In the confusion attendant upon the immobilization of the vehicles, enemy tank crews were to be wiped out.

Close-in suicide attack tactics were employed extensively throughout the Japanese Army. Although mines are still of use today for infantry company antitank defense, the previous mode of suicidal Japanese antitank tactics is no longer suitable as the principal element of modern combat against armor.

Armament

Rifle

At the time of the Russo-Japanese War, rifles were the only firearms of the infantry company. With the subsequent adoption of tactics involving extended formations, it became necessary to introduce a rifle equipped with telescopic sights, in order to spot and fire at small, well-camouflaged targets moving in and out of view. The new type of equipment was supposed to be issued to rifle squad snipers, but there was never enough to go around.² To achieve rapid-fire action, an automatic rifle was designed, but user units never received this weapon.

Light Machine Gun

Sustained rapid-fire guns developed remarkably after the end of the Russo-Japanese War. Light weapons which could be handled and fired by the individual soldier were adopted as major weapons of the infantry squad. When fitted with an artillery-type sight, the light machine gun became a precision weapon, used widely by the Japanese Army. The Model 11 light machine gun³ frequently broke

2. Problems of ammunition were paramount. The standard infantry rifle, Model 38 (1905), fired 6.5-mm. ammunition, but the short-barrel Model 99 (1939) sniper rifle fired 7.7-mm. cartridges. A 6.5-mm. sniper rifle (Model 97, 1937) proved unsatisfactory in performance. - Ed.

3. The basic Japanese light machine gun was the "Nambu" Model 11 (1922), 6.5-mm., a modification of the French Hotchkiss weapon. The Model 96 (1936) 6.5-mm. light machine gun later replaced the Nambu in large part, but the Model 99 (1939) 7.7-mm. version never went into mass production. - Ed.

down, however, and was especially susceptible to dust stoppages.

Grenade Discharger

After the Manchurian Incident, the infantry felt a keen need for high-angle weapons. Mortars, for example, had dead space within ranges of less than 600 meters.⁴ To eliminate this weakness, the grenade discharger--light and extremely effective--appeared ideal.⁵ Within the infantry platoon, a grenade discharger squad was accordingly organized and equipped with four launchers, designed to neutralize the heavy weapons of the enemy infantry and to pave the way for ground assaults. The grenade dischargers were regarded as exceedingly effective. From the point of view of ammunition, the dischargers were particularly valuable, inasmuch as they could fire hand grenades available to the individual infantryman.

4. The author is referring to the 70-mm. Model 11 mortar (1922).
- Ed.

5. Among the first efforts to provide Japanese infantry with heavy weapons, the 50-mm. Model 10 grenade discharger was introduced in 1921. This launcher was subsequently replaced by the Model 89 (1929) 50-mm. grenade discharger. In Japanese Army terminology, the Model 10 discharger was called "light"; the Model 89, "heavy". The author is alluding to the so-called "heavy" model in all of his references to the grenade discharger. - Ed.

Personnel Strength

At the time of the Russo-Japanese War, the 200-man infantry company was equipped with 180 rifles. When company strength was hiked to 250 during the wartime organization of 1914, all personnel were issued rifles, except officers and master sergeants. In 1922 the infantry was reorganized, and the standard three-platoon company was assigned a strength of 198 (see Figure 1). Each combat platoon consisted of four rifle squads and two light machine gun squads. Two grenade dischargers, not a part of the table of equipment of the company, were issued to each platoon. About 1937 some platoons belonging to units stationed in Manchuria were reorganized into four light machine gun squads and one grenade squad. Then, around 1940, a new table of organization was issued, prescribing an infantry company composed of three new-style platoons, one heavy machine gun platoon, one antitank gun platoon, and a supporting ammunition platoon (see Figure 2).

Since the days of the Russo-Japanese War, the rifle squad consisted of twelve soldiers. Two of these men were later assigned to be snipers and were supposed to be equipped with the appropriate telescopic devices but, as we have seen, the sniper rifle was never

6. Officers, warrant officers, and master sergeants carried the pistol and saber; some noncoms and enlisted men (in light machine gun squads, etc.) bore only pistols. - Ed.

7

universally distributed to user units.

The light machine gun squad, built around one piece, comprised twelve men. Ammunition carriers bore rifles (sometimes sniper rifles).

There were usually four launchers (but sometimes two) per grenade discharger squad of twelve men, the ammunition carriers being equipped with rifles.

With the increasing difficulty and intricacy of the company commander's front-line responsibilities, and the extensive introduction of tactics of extended-formation deployment, it was sometimes suggested that a deputy company commander should be provided. The question will doubtless arise in the future, whenever infantry company functions are re-evaluated.

7. The creation by the Soviets of a formidable tochka (pillbox) system of fortifications around Manchuria in the early 1930's exerted great effects upon Japanese Army doctrine and materiel. Emphasis upon snipers to cope with "invisible" targets was one of the many consequences. - Ed.

FIGURE 2

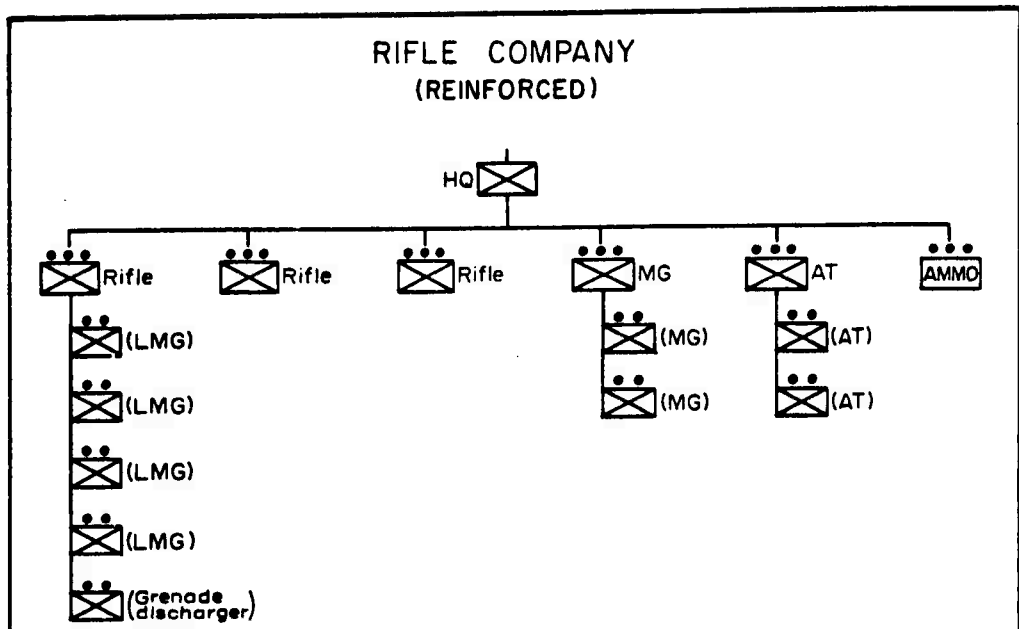

PERSONNEL STRENGTH		
COMPANY CO	CAPT	1
HQ	(SEE FIG. 1)	
LMG SQD	NCO	1
	EM	12
	EQP	1 LMG
GRENADE DISCHARGER SQD	NCO	1
	EM	12
	EQP	4 GRENADE DISCHARGERS
MG SQD	NCO	1
	EM	10
	EQP	1 HMG
AT SQD	NCO	1
	EM	10
	EQP	1 AT RIFLE (20-MM)
AMMO PLAT	NCO	1
	EM	10
TOT PERS STRENGTH		APRX 260 OFFICERS & EM

EQUIPMENT	
RIFLE	156
LMG	12
HMG	2
AT RIFLE (20-MM)	2
GRENADE DISCHARGER	12

Infantry Battalion

The Japanese Army's smallest single tactical unit capable of conducting combat operations was the infantry battalion. With a personnel strength of approximately 1,000 men, the formation was equipped with sufficient weapons, horses, vehicles, and material to facilitate the battalion commander's tactical control. Since, in general, the Japanese Army was geared to horse traction, the infantry battalion had a comparatively large table of organization, which made the exercise of command difficult. The new demands of modern warfare, however, required a reduced organization and an enhanced mobility, through mechanization. Tentative plans for an appropriate reorganization along these lines were worked out by the Japanese but never implemented.

Heated debates centered about the optimum number of companies which should comprise an infantry battalion; e.g., three or four companies. It was eventually decided that the four-company system would be advisable in order to maintain troop combat strength when breaking through enemy defenses established in great depth (as in the case of the Soviet Army). The standard infantry battalion consequently included a headquarters, four infantry companies, one heavy machine gun company, one infantry gun company, one battalion ammunition platoon (the "combat train"), and one platoon-size supply train. (See Figure 3).

Although the Japanese Army, as stated above, finally adopted a four-company system, the future organization of the infantry battalion should preferably be built around only three infantry companies. At the same time, the number of heavy machine guns should be increased; antitank guns should be incorporated into the battalion's table of equipment; and signal and intelligence platoons should be set up. Systems intended to achieve superiority by means of increased troop strength should be rejected, for it is essential that command and reconnaissance organs, as well as the quantity and quality of weapons, should be in complete harmony with the nature of modern warfare. Every effort should be devoted to achieve mechanization; battalion vehicles patterned after the light armored car are desirable.

Antitank Weapons

The exigencies of modern warfare increased the importance of antitank weapons. It was therefore thought best to provide the infantry battalion with an antitank combat unit, a concept which materialized throughout the Japanese Army as a whole and the Kwantung Army in particular.

8. Relevant materiel included Model 94 (1934) 37-mm. "infantry rapid fire gun;" and Model 1 (1941) 47-mm. "mobile gun". - Ed.

FIGURE 3

INFANTRY BATTALION
(STANDARD)

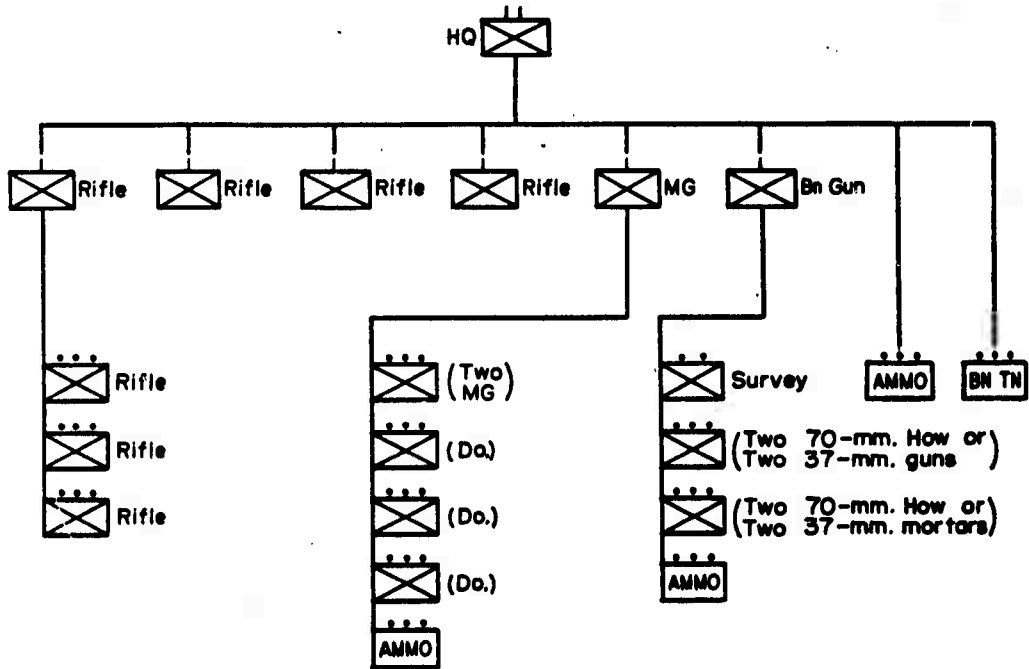

Total Pers Strength — aprx 1,000 officers & EM

EQUIPMENT	
RIFLE	552
LMG	25
HMG	8
HOW (70-mm.)	4
OR	
GUN (37-mm.)	2
a	
MORTAR (70-mm.)	2
GRENADE DISCHARGER	24

Liaison and Supply

Battalion headquarters was a command post controlling the activities of arms assigned or in direct support during combat. A liaison section was accordingly set up within the headquarters to facilitate command and liaison, using wire and radio communications as well as messenger dog teams.

Making use of pack horses, the battalion ammunition platoon (combat train) functioned to replenish munitions, chemical warfare materiel, medical supplies, and entrenching tools. The horse-drawn supply train hauled provisions, baggage, tentage, and mess gear. The combat train's pack horses numbered about 40; the supply train's draft horses, approximately 20. Any increase in supply capabilities was rendered difficult because of limitations in the availability of organic horse traction. In addition, the animals presented high silhouettes and easy targets. For these and other reasons, it was deemed best to utilize motor transport, with light armored vehicles replacing horses—a plan which never materialized.

Heavy Machine Gun Company

The heavy machine gun appeared in production shortly after the Russo-Japanese War.⁹ Subsequent to World War I, the infantry batta-

9. The 6.5-mm. Model 38 (1905) heavy machine gun appeared slightly too late to be used in the Russo-Japanese War. The 6.5-mm. Model 3 (1914) version was not replaced until the 7.7-mm. Model 92 was introduced in 1932. - Ed.

lion was issued four to eight of the heavy machine guns. In operations against the hypothetical Soviet Army foe, however, the necessity for providing front-line companies with machine guns was keenly felt, and eventually (in mid-1940) these weapons were issued to the infantry companies. It was determined that each battalion ought to possess a minimum of 8-12 machine guns, but this intention was never realized.

Machine gun companies consisted of a headquarters, four platoons equipped with two machine guns each, and one ammunition supply platoon.

Battalion Gun Company

The most important mission of an infantry battalion is the destruction of enemy heavy weapons. After World War I, the problem was assiduously studied. Two types of gun were adopted: the flat-trajectory infantry gun¹⁰ and the high-angle mortar¹¹. Appropriate unit reorganization which ensued was put to the test during the Manchurian Incident. Afterwards, a double-purpose infantry gun (capable of either flat-trajectory or high-angle fire)¹² was designed. It was decided to issue this type of artillery to the standard Japanese infantry division, built around its horse traction. In practice, the dual-purpose battalion gun left much to be desired regarding effectiveness and mobility; the mortar was considered to be su-

10. Model 11 (1922) 37-mm. gun. - Ed.

11. Model 11 (1922) 70-mm. mortar. - Ed.

12. Model 92 (1932) 70-mm. howitzer (battalion gun). - Ed.

perior in these respects.

The battalion gun company consisted of two platoons (with two field pieces each), a headquarters observation section, and an ammunition platoon.

Army Dogs

Within the battalion liaison section, a team of about a half-dozen German shepherd dogs was organized for military purposes. After the outbreak of the China Incident the Army established dog training centers at key points in the overseas theaters, where canines were bred. Private breeders were also stocked and counseled, and the Japanese public in general was encouraged to breed Army dogs.

Chemical Warfare

The Japanese Army perfected chemical warfare measures after gas was used by the belligerents in World War I. It also appeared increasingly likely that the Soviet Union, a hypothetical enemy of Japan, would employ poison gas in war. Individual soldiers were therefore provided with gas masks, light-weight protective clothing, and decontamination pouches for personal sterilization. For purposes of collective protection against chemical warfare, it was decided that the battalion ammunition train should carry materials necessary to decontaminate affected areas.

Great importance was attached to the use of non-toxic smoke for screening purposes. The battalion possessed smoke pots, shells, grenades, and candles.

PHOTOGRAPH NO. 1

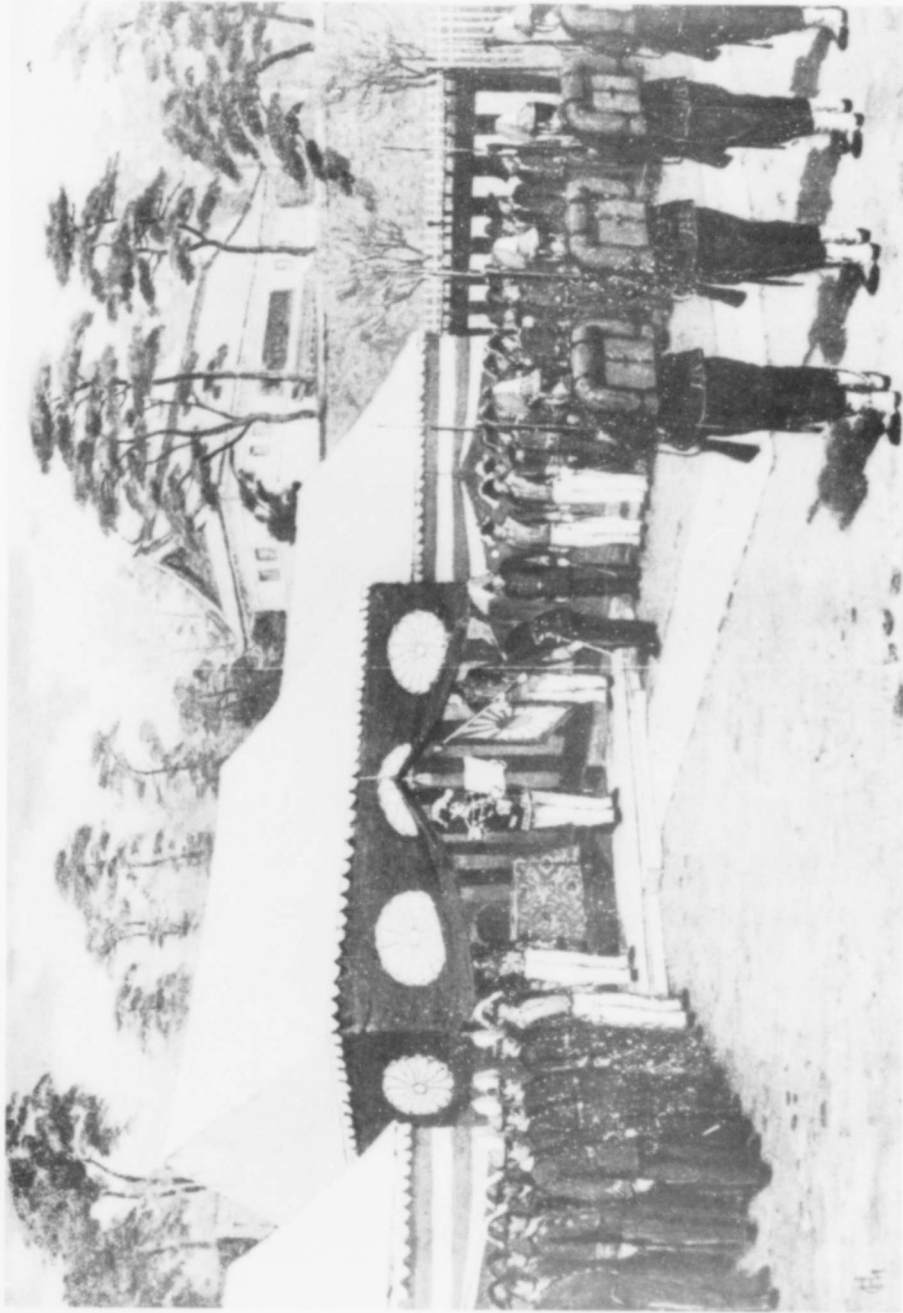

PRESENTATION OF IMPERIAL COLORS TO 1ST INFANTRY REGIMENT,
GUARD DIVISION HIBIYA PARADE GROUND, 23 JANUARY 1874.

REPRODUCTION OF PAINTING BY HORYU GOSEIDA

Infantry Regiment

The infantry regiment is characterized by its ability to execute separate and independent combat operations. Centered upon the unit colors, the regiment fights gloriously in battle, upholding and fostering the history of the regimental officer corps and the spirit of moral unity inherent in the regiment. Above all else, the regimental colors represent the officers' and men's core of unity and morale. These colors, passed down since the founding of the individual regiments, are revered by all ranks. (See Photograph No. 1).¹³

Since the days of the Russo-Japanese War, the infantry regiment was organized along triangular lines: Regimental headquarters, three infantry battalions, one regimental infantry gun company (or battalion), one signal company, one engineer unit, one regimental ammunition platoon, and one supply platoon. (See Figure 4).

Regimental Gun Units

It appeared highly advisable to provide the infantry with its own heavy weapons to knock out enemy counterparts. Regimental guns

13. The Emperor personally bestowed colors only upon each new infantry or cavalry regiment. As early as January 1874 the 1st and 2d Regiments of the Imperial Guard Division received their flags. During the Satsuma Rebellion of 1877 occurred the famous "disgrace" when Maj. (later General) Nogi lost his regimental colors to the insurgents (an episode which plagued him until his eventual suicide). During the Russo-Japanese War of 1904-05, every infantry and cavalry regiment in the Japanese Army participated in the fighting, which meant that 72 infantry and eight cavalry regimental colors acquired combat luster. - Ed.

were therefore included within the tables of equipment of the infantry regiment, shortly before the outbreak of the China Incident in 1937. Originally a 75-mm. mountain gun was adopted, but this weapon was later modified for specific infantry use, especially where ¹⁴disassembly was concerned. The decision was made to organize regimental gun battalions consisting of two batteries (four pieces each), but due to equipment shortages many units had to settle for one battery. A regimental infantry gun battery comprised a headquarters (with small command and liaison sections), two gun platoons, and an ammunition platoon. One gun platoon was made up of an observation section and two squads (one piece each). Regimental gun units of this type usually operated in close support of the foot troops and displayed great effectiveness in action.

Signal Company

A signal company handled wire and radio communications between regimental headquarters and higher echelons (infantry brigade or infantry group), as well as with the subordinate infantry battalions. The signal unit usually consisted of one wire platoon and one radio platoon, the former being equipped with some sixteen kilometers of wire strung by seven teams. The radio platoon, comprising six

14. For its regimental gun, the infantry was provided with the 75-mm. Model 41 (1908) mountain piece. - Ed.

FIGURE 4

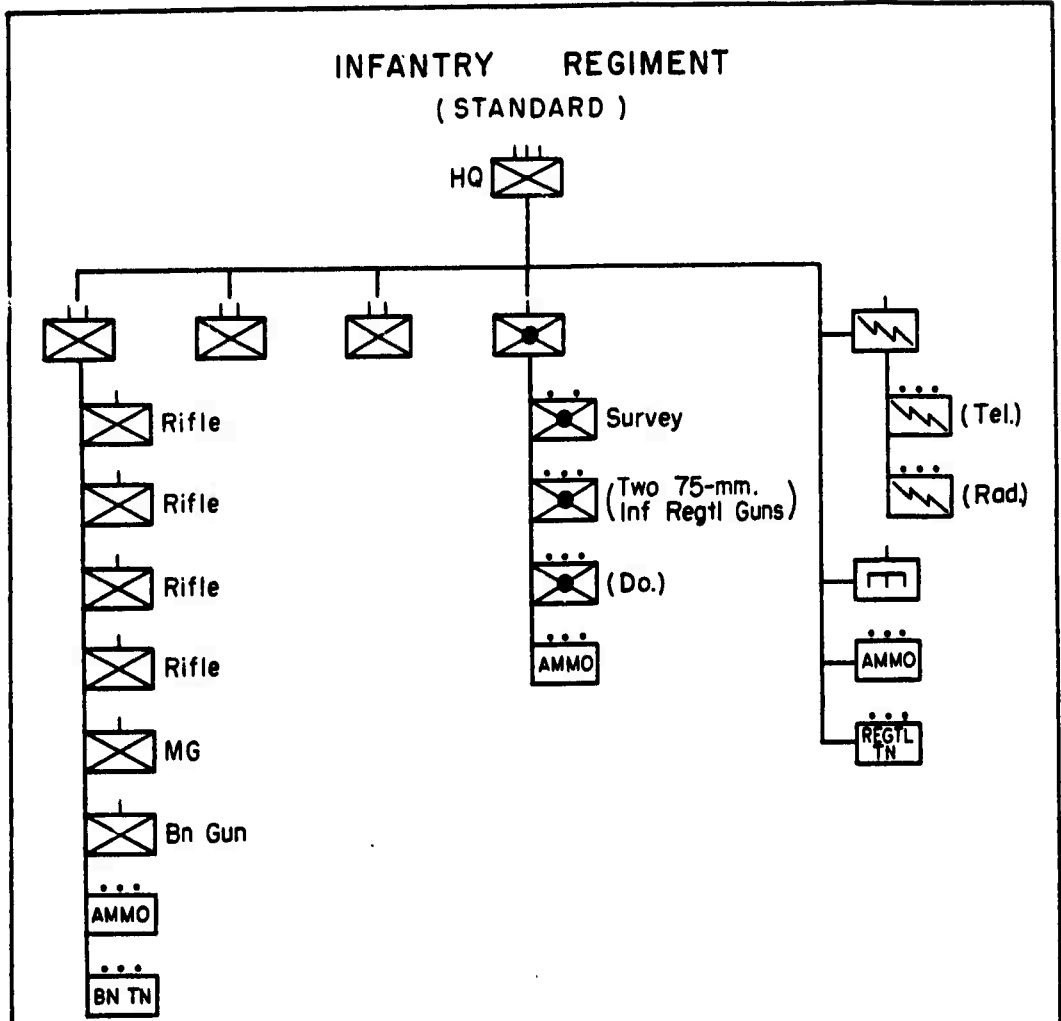

EQUIPMENT	
RIFLE	1,656
LMG	75
HMG	24
HOW (70-mm.) OR GUN (37-mm.) & MORTAR (70-mm.)	12 6 6
GUN (75-mm.)	4
GRENADE DISCHARGER	72

teams, was responsible for setting up a wireless network (range 6 kms.) between the headquarters. For auxiliary communication, flags and blinkers were employed on occasion.

Although, in general, the communications system at the regimental level progressed remarkably after World War I, the specific field of radio never kept pace with technological advances elsewhere.

Infantry Engineers

Divisional engineers supported regimental infantry operations entailing technical requirements (see itemized description, below). With the latest developments in modern warfare, however, engineering burdens fell more heavily upon the infantry units themselves. It was therefore decided, immediately prior to the outbreak of the Pacific War, that an organic engineer unit should be established within the infantry regiment.

15. In any general discussion of Japanese Army signal communications, the author feels that mention should be made of the fact that high-frequency and cryptographic systems proved drastically unsatisfactory in the prewar years—defects which were eventually unmasked in the course of the Pacific War.

16. In the text, a differentiation is made between the sagyo-tai (infantry engineer units) and the men of the kohei rentai (divisional engineer regiment). - Ed.

As their name implies, infantry engineers must function as combat infantrymen as well as front-line engineers. Optimum engineer strength built into the infantry regiment might consist of one three-platoon infantry engineer company, equipped and trained to handle all of the tasks facing it. Due to problems of training and organization, however, only one platoon-size infantry engineer unit was generally incorporated into the Japanese infantry regiment. It goes without saying that such a small unit could not handle all of the following infantry engineering missions.

1. Assault preparations: Destruction of wire entanglements by use of Bangalore torpedoes. Cutting of barbed wire. Mine clearance. Flame thrower assaults on pillboxes.
2. Antitank combat: Close-in attack against armored vehicles.
3. Fortification construction: Erection of shielded structures, tunneled works, and obstacles, Camouflage of main defenses. Storage and maintenance of fortification materiel.
4. Expedition of tactical penetrations: Construction, under fire, of trench works within enemy positions; destruction of hostile counterparts; elimination of obstacles; erection of emergency bridges; repair of passages.
5. Chemical warfare: Use of smoke. Anti-gas protective measures.

Infantry Brigade and Infantry Group

The commander of an orthodox "square" division directly controlled two infantry brigades, made up of a headquarters and two regiments each. A new-style triangular division comprised one infantry group consisting of a headquarters and three line regiments. (See Figures 5 and 6).

Controversy long centered around the optimum regimental strength of an infantry division; i.e., three or four regiments. At the time of the Russo-Japanese War, there were no doubts that two infantry brigades were best, but after World War I, when it became necessary to reorganize the Japanese Army setup, the triangular system was studied. Shortly after the outbreak of the China Incident, the triangular division gained favor, and three-regiment infantry groups were accordingly established.

In combat involving key areas, brigade or group commanders coordinate and execute the operations of the infantry regiments and supporting units. In practice, however, the group headquarters was set up with only a minimum capability of exercising command over subordinate echelons. Lacking a signal unit, for example, the group headquarters had to depend upon the division and the regiments for communication linkage. Under the circumstances, the opinion prevailed that it would be advisable to create the post of Assistant Division Commander at divisional headquarters, rather than to retain

a largely impotent infantry group headquarters.

In the event of hypothetical operations in Manchuria, it is believed that the tables of organization and equipment of the infantry brigade should be modified. A powerful mechanized reconnaissance regiment ought to be incorporated, in order to cope with guerrilla warfare and airborne operations conducted by Red armies on an extremely large scale. Infantry group headquarters must be strengthened with units required for intelligence, communications, and command functions.

FIGURE 5

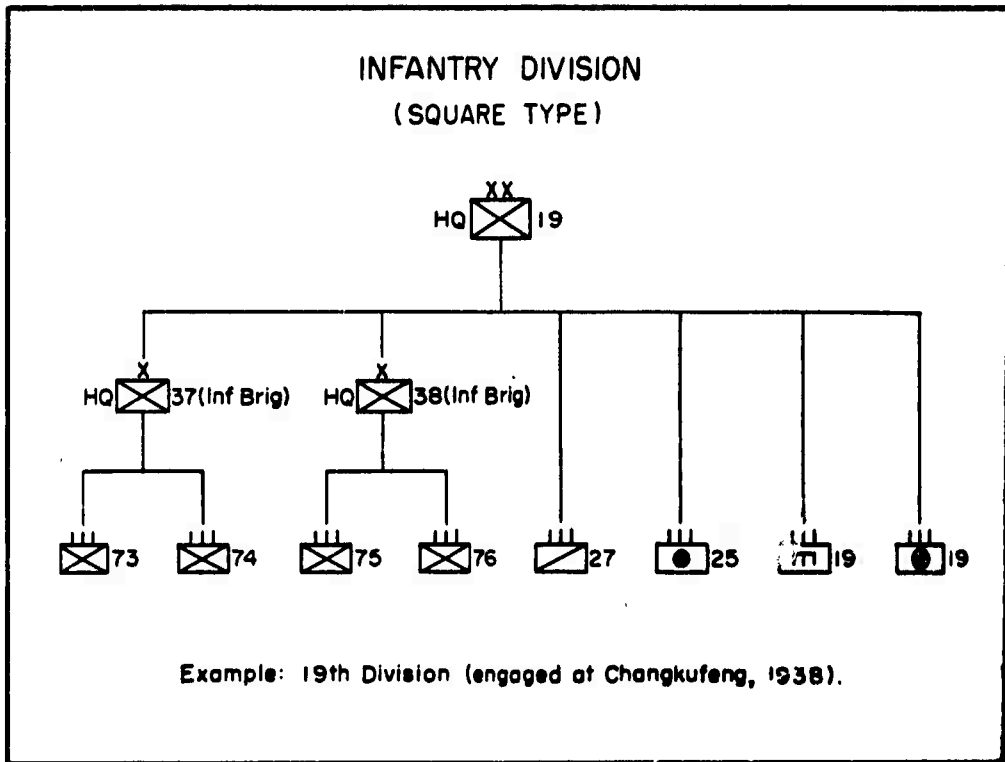
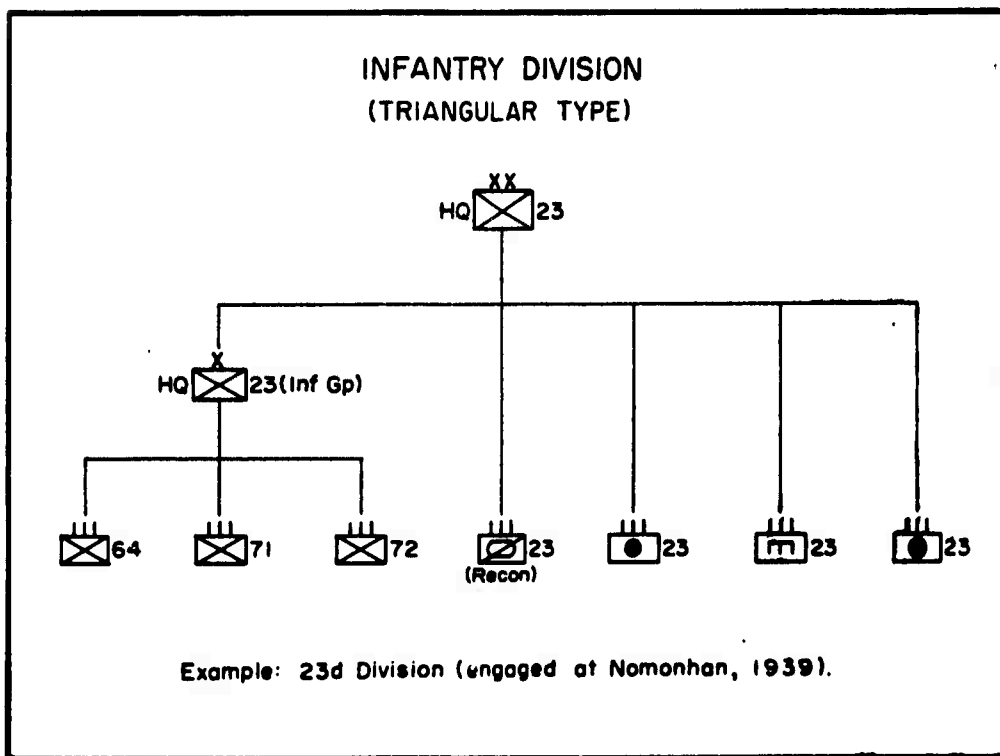

FIGURE 6



Fundamentals

Forces committed to Manchuria require certain specialized types of organization. The following discussion, although it is aimed primarily at the infantry, is not limited exclusively to that combat arm.

Infantry regiment and battalion headquarters must possess a company and platoon, respectively, to handle quartering, security, fortification, etc. In the prewar Japanese Army, troops had to be pulled out from the line companies for temporary duty of the type previously described. The companies inevitably were plagued by personnel shortages, and the headquarters were hampered and inconvenienced accordingly.

A medical and water supply system must be perfected. Water--especially potable water--is hard to get in Manchuria. The inhabitants are germ-ridden and their lack of hygienic sanitation is widespread. In addition, if the Communists are the enemy, it can be expected that they would resort to diabolical bacteriological warfare. It follows that regimental and battalion headquarters (plus the division, of course) must organize comprehensive medical and water supply facilities.

Psychological warfare countermeasures would pose another extremely critical problem for armies operating in Manchuria against potential foes in the Red bloc. The danger appeared far less urgent at the time of the Manchurian Incident (1931) but, as the years

went by, the Japanese gradually recognized the remarkable importance of psywar activities. Countermeasures against psychological warfare must be systematized in the future. At division and regimental headquarters, staff officers must be assigned with the primary mission of devising defenses against ideological warfare. This effort must also be carried out by trained personnel at the battalion and company level.

To maintain the nutritional health of troops in Manchuria, rations must be drastically improved over prewar standards. In the Japanese Army, many suffered from malnutrition due to excessive consumption of starchy foods. Albuminous and fatty substances must be included in rations, especially during seasons of extreme cold.

Infantry units must possess, at any cost, flexibility in command and maneuver--to embrace mechanization, intelligence, and communications, as well as control. These requirements are dictated by the terrain of Manchuria and the peculiarities of Communist tactics. Although the Japanese Army always stressed maneuverability in Manchuria, almost no progress was ever made; weaknesses frequently came to light during campaigns to subjugate bandits. Modern Red forces, on the other hand, are noted for extensive use of air, ground, and guerrilla warfare, without respect to any particular areas of attachment. They display daring in attack or retreat operations.

CHAPTER 2

TACTICS

General

The tactics formulated and prescribed in the Field Service Regulations and the Infantry Training Manual derived from two precepts: (1) All-out warfare would be fought on Manchurian terrain (especially on the major battle fronts there); (2) the enemy would be organized, equipped, and trained like the Soviet Army, Japan's hypothetical foe. Japanese tactics, organization and materiel nevertheless could not keep pace with the latest developments in modern warfare, because of insufficient natural resources and inefficient production of munitions. As a consequence, tactical precepts unfortunately could not be exploited to the full.

The infantry's mission was to fulfill a major combat role as the main element of the Army, while forming the core of combined operations involving various arms, in order to deal a decisive blow to the enemy. Regardless of terrain or weather, the infantry was to assault the foe and destroy him, even when support was not available.

Intensive artillery bombardment and massive use of armor characterized Soviet combat action. For these and other reasons, including the nature of the Manchurian terrain, it proved especially imperative to stress extended-formation tactics of dis-

persion in the training of individuals and units. In the execution of such tactics, it is always necessary to consider the abilities of the soldiers and the level of their training; otherwise, control would be lost and the achievement of fighting effectiveness would be rendered difficult. As the record of the Pacific War indicates, Japanese training in dispersed tactics proved far from satisfactory.

Although great attention was devoted to the problems of air defense and antitank combat, the requisite equipment could never be supplied on a large-scale basis as planned, due to shortages. It therefore became necessary to devise special tactics to make up for deficiencies in materiel.

The neutralization of the Soviets' mighty firepower was the Japanese Army's primary concern. Special emphasis was accordingly attached to the technique of night attacks. On occasion, when projected assaults were to be conducted in daylight hours, dawn or dusk operations were stressed, in order to exploit the effects of surprise. On the vast flatlands of Manchuria, the maintenance of direction during night operations poses a problem, and appropriate training had to be conducted, especially in the use of the compass.

It is a truism that intelligence is a key to victory in battle. In the case of the prewar Japanese Army, however, it cannot

be denied that intelligence planning was ignored throughout all phases of peacetime organization, equipment, combat, and training. As a consequence, weaknesses in the intelligence setup became clearly apparent during the Nomonhan Incident and the Pacific War.

In the case of the China Incident, the inefficient intelligence system of the Japanese Army was masked by the fact that it was easy to obtain intelligence about the Chinese, who were, in general, weak and demoralized. By deciphering the enemy's codes, the Japanese could secure the accurate data desired. Later, however, during the Kanchatzu (1937), Changkufeng (1938), and Nomonhan (1939) incidents, Japanese Army field commanders experienced extreme difficulties because of the lack of intelligence concerning the Soviet Army. Despite this bitter experience, the overall situation was never improved during the Pacific War, and the consequences are obvious. In view of the excellent intelligence network of present-day Communist forces—a hypothetical enemy—the organization and training of intelligence units which are to operate in Manchuria must be thoroughly reorganized in the future.

Combat Frontages and Depths

Appropriate deployment in hypothetical combat against the Soviet Army was imperative. Frontages and depths were determined in conformity with Japanese Army unit organization, as well

as with the nature of the fighting itself. Standard reference figures envisaging combat on major battle fronts are presented in Table 1; the rules are not hard and fast, however.

If the old standards are viewed in the light of the experience acquired in World War II, the desirability of further dispersion becomes evident. In practice, this goal may prove difficult since vast numbers of personnel will have to be mobilized in the event of total war, and their versatility may not be satisfactory in effecting difficult tactics of dispersion.

Table 1

**Standard Infantry Combat Frontages and Depths
(Distances in Meters)**

	Offensive*		Defensive	
	Frontage	Depth	Frontage	Depth
Platoon	130	150	200	150
Company	300	500	600	500
Battalion	800	1,500	2,000	1,500
Regiment	1,800- 2,000	3,000	3,000	2,000

* Offensive operations involving attacks against prepared positions.

Attack Operations

Whether in battles of encounter or in attacks against enemy positions, offensive tactics have nowadays undergone change, to deal with the advent of air power and armor, and with technological advances in armaments and chemical warfare. Modern ground tactics therefore differ tremendously from the old line-formations employed in the Russo-Japanese War.

Dispersion has likewise become more pronounced. For example, in the early 20th Century the interval between individual skirmishers was two paces, but after World War I the distance was increased to 5-6 paces. Then again, within the squads, individual infantrymen now advance by bounds, instead of deploying in group formation. For the actual displacement forward, the soldier was taught to crawl, taking skillful advantage of the terrain.

Experiments were made with squad teams made up of two or three men each, using tactics of mutual support. Although never developed sufficiently to be included formally in the Japanese Army's Infantry Training Manual, team tactics were strongly supported in many quarters.

1. Following quotations based upon JRD monograph entitled Japanese Night Combat, Part 1, pp. 163-64. - Ed.

The concept of fighting team formation was developed about 1936 when the new organization which equipped each infantry squad with a light machine gun was conceived and adopted. A team method, designed to seize enemy positions by infiltration, was developed by Lt. Gen. Kanji Ishihara, commanding general of the 16th Division.

As one of the principal features of this tactic an infantry squad was divided into a support team (two or three soldiers with a light machine gun), a sniper team (two or three good marksmen), and two assault teams (about three men to each team). Assault teams approached the enemy pillbox by crawling and attacked it from its side or rear, under the covering fire of the support and sniper teams. The basic consideration underlying this tactic was the belief that a Russian pillbox could be captured by an assault conducted by seven to nine men, instead of requiring an entire infantry squad, previously considered necessary. ...

The method of fighting teams was adopted by the 16th Division, and other units followed suit. ...In the Night Attack manual,² published in 1944, the 16th Division method was recommended as the most common attack formation of the infantry squad. The supplement also recommended that the supporting and sniper teams be made into assault teams under certain circumstances.

2. A supplement to the classified training series on Anti-Soviet Army Combat Tactics (Taisogun Sentoho)—the so-called "Red Books", prepared between 1933 and 1935. - Ed.

In devising plans of fire, the sniper method was fully applied, using light machine guns or individual snipers within the infantry squads. When close-range, massed fire was required, the rest of the unit would open up, or would be used as assault troops for a charge. These tactics, of course, economized on ammunition, but their basic purpose was to save manpower in the face of superior Soviet fire, until the time was ripe for an assault.

Antitank Tactics

On the assumption that armor would always be encountered during any hypothetical war with the Soviet Union, the Japanese Army designed antitank weapons and devised antitank assault tactics. Great stress was laid upon suicide measures, such as close-quarter antitank combat. These tactics were further developed, especially during the last phases of the Pacific War, because of the following factors: shortages of antitank weapons; difficulties in ammunition supply; and combat lessons acquired in the course of the fighting in the Pacific. Training in the skills and the esprit required for close-in antitank warfare was demanded of every branch and service of the ground forces.

Antiaircraft Operations

Whether on the march or in combat, infantry units were to shoot down low-flying aircraft. This tactic is largely ineffective, however, against the latest types of modern planes, and may indeed prove

disadvantageous to ground troops.

To reduce losses and to mask intentions on the ground, the Japanese conducted ground movements and supply by night, as a rule. Extreme dispersion and the construction of defensive shelters were also stressed.

Gas and Smoke

Individual soldiers were taught to use gas masks, while contaminated areas were neutralized by infantry engineers. It is probable, however, that scientific advances in techniques and equipment will offset merely passive measures of defense against chemical warfare.

Smoke screens were utilized to blind the enemy; to reduce friendly losses; to render enemy gunfire ineffective; and, simultaneously, to shield friendly intentions. These tactics were originally employed on a small scale, by providing the regiments and lower units with smoke candles. Later, specialized infantry engineer outfits were organized to provide large-scale smoke screening for divisional-size units. Climate and weather became extremely important when smoke was used on a large military scale.

Attacks on Positions

During the Russo-Japanese War, the depth of a defender's entrenched positions or of his unit deployment was shallow; decisive

combat could therefore be expected near the front lines. Recent Soviet Army tactics, however, indicated a marked tendency to adopt deep positional warfare. Deployed in great depth, the Soviets would wear down and weaken the attackers within a defensive zone, after which they would seize the opportunity to launch counterattacks.³ The Japanese Army therefore decided to adopt tactics involving deployment in depth, to cope with the Soviet defensive concept. Regulations and manuals were accordingly revised in conformity with this principle, to ensure intensive training.

Combat Approach

When on the defensive, the Soviet Army could be expected to make use of long-range artillery, tank sorties, and aerial bombings. The Japanese felt obliged to resort to very greatly extended formation at a considerable distance from the battlefield. This method of approaching the enemy was intended to reduce personnel casualties and equipment losses. All the while, combat measures had to be readied against the threat of enemy armor, aircraft, and chemical warfare. When necessary, units approach-marched by stages rather than by the most direct axis.

3. For a graphic presentation of Soviet Army concepts of defense in depth, see Figures 1-5, Japanese Night Combat, Part 1, p. 19ff. - Ed.

Dawn or Night Attacks

Due to the Soviet Army's tactics and massive fire power, daylight attacks against main positions became increasingly difficult, and the employment of dawn or night attacks was accordingly encouraged. This change appeared inevitable, if the Japanese Army's pronounced quantitative inferiority in planes, guns, and tanks were to be offset. Ideally, open-daylight attacks against enemy positions were considered best, but this would have presupposed a build-up and enhancement of the Japanese Army's over-all material potential.

Combined Operations

Basic to infantry operations was the fundamental concept that supporting arms should render fire support without time lags. Avoiding casualties, the infantry companies should fully exploit this support and carry out immediate assaults after heavy weapons fire had had its effect. It therefore became ever more important to co-ordinate the operations of infantry, armor, artillery, and air power during attacks against positions. This teamwork was highly stressed in training.

The Field Service Regulations clearly stipulated that the co-ordination of the various arms was to be effected "in order to enable the infantry to attain its objectives." This principle was not altered after World War I. Judging from further experience in the China Incident, the Japanese felt that brilliant results were

achieved by those units which manifested confidence, gratitude, and consideration toward supporting arms. Supplements and revisions of the Field Service Regulations derived from this belief.

Night Attacks⁴

The Japanese Army devoted very great attention to night combat, a characteristic of Japanese warfare in general. Tactics of night combat proved highly effective in the Russo-Japanese War, and were widely used during the Manchurian Incident, the Changkufeng Incident, and the China campaigns.

Because of Japan's limited natural resources, the Army's organization and equipment could never keep pace with world-wide military progress. Night combat was an inevitable recourse, under the circumstances. The tactic was not only a source of terror to the enemy, but it exploited the characteristic abilities and bravery of the Japanese race. Encouragement for the adoption of night combat was lent by the Russian and Chinese fear of employing this tactic, and their lack of training against it.

Night attacks reduce losses and mask intentions. Despite inferiorities in weapons, ammunition, equipment, and (presumably)

4. The present discussion is necessarily of a generalized nature. Specific details and battle experience are comprehensively described in JRD study entitled Japanese Night Combat (Part 1: Principles; Part 2: Excerpts from Training Manuals; Part 3: Examples), May 1955. - Et.

manpower, the Japanese felt that night combat would enable them to apply their unique strengths and thereby destroy superior enemy forces. Regardless of size, infantry combat units were always to be ready to launch night attacks. Division-size elements were to launch this type of operation in order to exploit combat successes achieved during daylight hours (continuous attack) or to set up further offensive operations. The two most important factors upon which success in night fighting depended--careful preparation and high morale--were constantly stressed and nurtured in Japanese Army training.

Infantry troops serve as the core in a night attack. Recent advances in warfare, however, have rendered the defender's means of security and reconnaissance more thorough and systematic. There has consequently been a growing tendency for the attacker to lose the element of surprise and to have his intentions unmasked. Hence, there has been a trend toward assault tactics by strong forces co-ordinated with artillery, armor, and engineers.

During the Pacific War, in particular, there were many occasions when defending forces systematically detected the attack plans of the Japanese, and proceeded to change night into day by generating brilliant illumination. Massive fire power could then be concentrated upon assaulting Japanese troops, whose attacks

were bound to fail.

With the modern development of command organization, intelligence systems, illumination capabilities, and fire power on the part of the defense, more deliberate study and preparations will be required for the attacker to carry out future large-scale night combat. During the Nomonhan Incident and the Pacific War, there were a number of cases when Japanese forces could not completely penetrate enemy positions during a night attack, and then suffered crushing blows from systematic enemy bombings and armor counterattacks launched at daybreak. Under such circumstances the Japanese had no choice but to give up enemy positions seized at heavy cost. We can only conclude that large-scale night combat tactics will prove even more difficult in the future.

Fire Discipline at Night

During the Russo-Japanese War, night attacks which penetrated enemy positions brought about immediately decisive combat, inasmuch as the defenses comprised the front line itself. Objectives were consequently limited and close-in. More recently, positions have been established in depth, and decisive combat cannot be expected at the periphery. Attack objectives have to be selected within the deep defensive zone.

In the days when defenses were comparatively shallow, it was found that surprise could be best effected (and the danger of mis-

takes in recognition eliminated) if the use of fire was prohibited. The Japanese Army therefore absolutely forbade the loading of weapons by troops participating in night attacks. With increases in positional depth, however, the attackers' plans would inevitably be exposed after an initial penetration had been accomplished. The enemy would certainly open fire upon the attackers, who would in turn be forced to return the fire. Taking these new developments into consideration, Japanese Army tacticians were obliged to make certain changes in the doctrine of night combat.

It should be noted that increases in depth were not an exclusive function of the defense but characterized the offense as well. Night attack formations usually had to strike in considerable depth, with units held in rear to exploit first-line penetrations, by leap-frogging to attack the next objectives.

Night attacks employing firearms were only launched under two circumstances. When it was desired to commence with a surprise attack followed by the use of weapons; or when firearms and tank support were to be used from the very beginning. Night onslaughts of this type were carried out on comparatively numerous occasions from the time of the China Incident.

Dawn Attacks

During the Russo-Japanese War, the Japanese Army acquired valuable experience in methods of approaching the enemy under cover of darkness, of preparing to attack in front of hostile positions before dawn, and of penetrating defenses in force at daybreak. Such tactics were deemed most advantageous in terrain such as Manchuria.

The "Red Books" laid stress on special attack methods utilizing meteorological characteristics of high latitude districts (about 50 degree north latitude) in northern Manchuria /where/ the Japanese Army discovered that the half-light of the early morning continued for a comparatively long period. The early morning light normally permitted visibility up to several hundred meters but did not afford that of several thousand meters, the distance required to permit the artillery to open fire. To the infantry of both sides the morning light was practically daytime, but as far as the artillery was concerned, night conditions prevailed. ...How long the early dawn would last depended on the latitude, the season, and weather conditions. It usually lasted from 30 to 60 minutes, although it frequently lasted more than an hour.⁵

The orthodox concept of dawn attacks (Futsugyo Kogeki) called for the assault units to approach and deploy in front of the enemy positions during the night, and to complete attack preparations before dawn. Jump-off positions were necessarily close to the enemy lines (sometimes 200 or 300 meters away), but they could not be ex-

5. Ibid., Part 1, pp. 35-36. - Ed.

cessively close, because at the break of day ~~Friendly~~ artillery would unleash a preparatory bombardment lasting an hour or more. When the concentrated barrage finally lifted, the infantry would immediately rush the enemy positions. These tactics possessed certain inherent drawbacks:

If the infantry attack was to be preceded by artillery preparation, the period during which the infantry stands by under enemy infantry fire would have to be extended until the end of the early dawn period. On the other hand, the earliest period of early dawn, a brief period of about ten minutes when visibility is limited to forty of fifty meters, was recognized to be a time of greatest advantage to the attacking infantry. This period meant night time visibility for distances over 100 meters for the defense, but it was possible for attacking infantry troops to advance, since they required a shorter range of visibility. It was considered possible for infantry advantageously to employ night combat tactics in the early dawn.

A variant dawn attack tactic, the Reimei Kogeki, was accordingly devised. During the hours of darkness, assault troops were to occupy jump-off positions very close to the enemy lines. At the first signs of dawn, the infantry would attack without artillery preparation or support, and would seize the enemy's front-line defenses. After daybreak, artillery and armor would lend support to deep penetrations made by the infantry. This type of dawn attack was well-adapted to latitudes such as Manchuria, where the

6. Ibid., pp. 36-37. - Ed.

protracted half-light of early morning greatly restricts visibility, especially in summer. Under these circumstances, attacking forces derive considerable freedom of movement, whereas the defenders cannot exploit their full firepower.

7

Dawn Attacks by Combined Arms

Prior to the usual dawn attack (Futsugyo Kogeki), advance elements seized hostile outposts or forward positions, then probed for the location of the main line of resistance. The senior commander (of higher than division commander rank) drew up plans for attack and issued orders, whereupon the attack units deployed during the night preceding the dawn assault. All preparations were completed before daylight. The staging of a dawn attack took at least two nights for units of army size. On the first night, the army would complete its deployment; on the second, the attack forces would take position as close to the enemy lines as possible.

After daybreak, the artillery was to neutralize enemy positions, destroy obstacles, and unleash a short barrage in support of the infantry's attack. Deployed to the rear, armor was now to exploit the artillery preparation. Overtaking the assault troops, the tanks would breach a path for the foot soldiers by knocking out obstacles in front of the enemy positions, which would then be overrun.

7. Also see ibid., Part 1, pp. 70-71; and Part 2, pp. 194-97 (excerpts from Japanese Training Manuals). - Ed.

The infantry assault waves pushed forward in order to be able to jump off as soon as the friendly artillery bombardment had lifted, whereupon they could storm hostile positions with armor and artillery support, and exploit local successes.

Tactics of Futsugyo Kogeki were conducted when the time for the attack was fixed beforehand. The infantry assault was set in motion by the artillery barrage, and these two arms plus the armor had to function in close concert "as one body." Commanders must exercise this tight co-ordination at the battalion level; by direct, mutual co-operation, they can thoroughly familiarize themselves with existing battlefield conditions.

Unfortunately, Japanese artillery units had a bad habit of firing only from the rear, without moving up to the dangerous advanced positions. The manuals had to be revised to correct this fault, and the artillery was accordingly required to follow the infantry closely and to maintain close co-ordination with them.

The concept of Reimei Kogeki operations (sometimes called "early dawn attacks") involved no artillery support for the infantry assaults. Infantry attack positions were to be set up as close to the foe's main line of resistance as possible without being hampered by hostile fire; say, 200 meters or less. Co-ordination of infantry, tank, and artillery units would be effected during the combat inside enemy positions, after daybreak. This co-operation was to be governed by the degree

of success obtained by the forward waves of infantry, and both the artillery and armor commanders had to work together with them very closely at the battalion level.

Tanks sometimes supported the infantry's action from the very beginning of Reimei Kogeki operations. When the artillery was able to carry out accurate night bombardments, and when their action seemed advantageous, they too might render direct support prior to the actual ground assault (as in the case of the Futsugyo Kogeki, described above).

Maneuvers and training performed by Japanese Army units stationed in Manchuria after the China Incident supported the belief that Reimei Kogeki tactics were particularly well-adapted to the peculiarities of northern latitudes on the Continent.

8

Dusk Attacks

In northern Manchuria the period of dusk is comparatively long, and a dusk attack was another application of night combat tactics. The infantry committed in a dusk attack starts action after sunset as visibility becomes progressively less, and penetrates the enemy position under the concealment of full dusk. It was considered possible for attacking infantry troops to approach enemy defense positions without observation.

The dusk attack method could be used advantageously in continuing an attack to exploit successes gained in daylight attacks or in assaulting enemy outposts. It could also be utilized as the initial phase of a night attack which would require most of the night to complete.

8. Based upon ibid., Part 1, p. 37. - Ed.

Defensive Operations

Field Positions

The Japanese Army was always averse to defensive action. Regulations and manuals therefore stipulated that defensive operations should be executed only when there was no alternative. A maximum degree of initiative was to be displayed, and the defender was to go over to the offensive at the very first opportunity. Aggressive measures were to be used to crush enemy attacks in the forwardmost parts of the main defensive positions.

Active defense was formerly stressed as the prime objective of defensive training. Later, however, when the regulations and manuals were revised, extremely difficult combat situations (in which the minimal objectives of the defense are barely secured in the face of overwhelming enemy superiority) were treated as "standard."⁹

Zones of Resistance

To cope with the enemy's superior artillery, aviation, and mechanized forces, the Japanese Army exploited terrain advantages, which would prevent the foe from developing his full power.

In establishing a zone of resistance, the infantry division would divide its frontage into sectors, each held by a half or full regiment. Individual sector units, with one infantry battalion as their core, would secure key positions, maintain contact with vital

9. See Appendix A. - Ed.

adjacent defenses, and establish deep positional zones for the reserve units to the rear of the key positions. A single "key position" would comprise two or three infantry companies at the front, with reserve units behind, in order to provide autonomous defense.

Progress in modern warfare made it inevitable to expect hostile armor to effect penetrations of friendly positions. Manuals were accordingly revised so that firepower and counterattacks would be properly employed to cope with enemy irruptions and assaults.

Infantry companies were to handle individual defensive missions within the key position system, and were to be able to defend themselves independently. Subsectors, built around a platoon, were to be set up within the company defensive zones, each separate position being capable of rendering mutual support to its neighbors. Squads, in turn, were to be deployed in depth within the platoon subsectors, in order to secure their positions and maintain close contact with adjacent squads, thereby delivering flank or oblique fire.

Fire Network

The establishment of a fire network must necessarily be tied in with the zone of fire of the artillery. In addition, however, the infantry should exploit its own organic firepower against attacks, and secure its positions by the use of both fire and counterattacks.

Platoon subsectors and key company defenses should utilize oblique, flank, and reverse fire, based upon the fire plan of the senior commander. In order to deliver concentrated and destructive fire from all directions against massed enemy forces, a number of "sudden fire" points should be established in the forward zone of the main defensive positions, making use of various types of guns.

Observations

It is inevitable that defenses will eventually be destroyed by an enemy. To the very end, however, Japanese Army defensive operations remained unsatisfactory in many respects, vs. attacks by superior enemy mechanized forces. Aggressive defense against armor and aviation was particularly inadequate.

10

Border Defenses

The fundamentals governing the setup of infantry positions belonging to border garrison units closely resemble those of field forces. Frontier defenses, however, adjoin the enemy front, and the foe's attack deployment must therefore be considered to be both complete and ready for action. Strong defensive cover must accordingly be provided, even for individual soldiers. Fire positions of

10. For comprehensive treatment of the subject of garrisons and fortifications, see Vol. XI, Part 2, Japanese Studies on Manchuria (Small Wars and Border Problems). - Ed.

garrisons must be plotted and shelters constructed to facilitate combat execution. Weapons and ammunition must be constantly ready, concealed in underground shelters which take advantage of the terrain. Defensive work must be especially strengthened.

Forest Fighting

The Japanese Army sought to derive maximum advantage from the terrain characteristics of the Manchurian forests, although the degree of tactical value depended upon local conditions, such as the density of tree growth. Especially in the case of penetrations through border defenses, the Japanese intended to surprise the enemy by traversing and attacking through forest land, regardless of the extent of wooded cover. The infantry devoted major attention to study and training for breaching various types of forest country.

In the dry air of Manchuria, forests are comparatively inflammable, even in spring and summer. This feature can be exploited when napalm weapons are to be used.

The actual military tactic of penetrating forests depends upon the degree of tree growth to be encountered. Most often the infantry organizes demolition squads, including engineers, to breach a path. "Trimming" teams lop off the lower branches of trees, whereupon "clearing" teams dispose of the deadwood strewn on both sides of the gap, in addition to removing fallen timber. On occasion, tanks have to be used to uproot thick underbrush and trees, which must then be cleared away. The width of the pathway should, in general, be sufficient to afford passage for vehicular traffic.

11. For detailed regional analyses, see Vol. III, Japanese Studies on Manchuria, Military Topography and Geography, Parts 1-3, passim. - Ed.

Penetration of lightly wooded areas poses an easier problem. Where the trees are small and the ground is masked with hedge growth, armored cars can be used from the outset to clear those portions which obstruct troop movement.

Swamp Fighting

Combat in Manchurian swampland varies greatly with the type and extent of affected terrain, as well as with seasonal characteristics. In general, however, enemy defense of marsh country can be expected to be perfunctory. Surprise--and victory--become easy if only the swamps can be traversed. The Kwantung Army was not unaware of this fact, and attached great importance to swamp-crossing tactics.

In the case of small marshes, crossings were effected by providing the individual soldiers with simple equipment such as ski-shaped footwear. Pathways were also made by covering swamp surfaces with available straw, shrubs, twigs, and branches. To get across a large swamp it was necessary to use bridging materiel; e.g., light boats, rafts, etc. In peacetime, special units were trained in the techniques and methods of breaching Manchurian swamp country.

12. See ibid., Parts 1-3, passim. - Ed.

Winter Fighting

During winter in Manchuria, temperatures vary considerably with the geographical latitude. When the temperature drops below -40 degrees C., large-scale military operations become extremely difficult. The Kwantung Army conducted various winter exercises to overcome the adverse effects of winter upon operations (especially where mobility was concerned).

The requirements for winter-weather operations greatly impede the actions of individual soldiers. Difficulties in operating fire control equipment slow down the combat employment of weapons. The tasks of transportation units are vastly increased by special needs for quartering facilities and logistics. Heating and water supply pose acute problems, which in turn hamper movement and fighting. Even slight delays in treating frostbite cases can cause more personnel casualties than combat itself.

Apart from low temperatures, as previously stated, the pronounced effects of wind upon body heat must be given especial attention in Manchuria. There is a rule of thumb that a wind velocity of one meter per second approximates one degree of temperature. For example, when the temperature reads -33 degrees C., and the wind velocity is 7 m.p.s., the effect upon body temperature is the equivalent of -40 degrees C.

13. For detailed consideration of winter operations and weather conditions, see Vol. IX, Japanese Studies on Manchuria. - Ed.

Manchurian winters are characterized by three days of cold, generally followed by four mild days. In planning military operations and movements, this climatological characteristic should be exploited. The worst times of the year for the execution of ground operations in Manchuria occur for approximately two weeks in November, when the freezing season begins; and a similar period in March, when the thaws set in.

Special Considerations

The experience of the Japanese Army in Manchuria suggested the following characteristics of combat during severe winter weather:

1. Distances to be crossed at a bound by skirmishers must be cut in half.
2. Gloves may be removed only when a man is actually firing a weapon, but must be replaced immediately thereafter.
3. To conserve physical strength as well as morale, distances involved in assault operations should be shortened as much as possible.
4. Attacks over icy terrain require precautions against slips and falls.
5. The duration of sentry duty should be reduced by one-half or more.
6. Since normal cover is difficult to construct because of the frozen ground, sandbags and heaped snow should be skillfully utilized.

7. Weapons and equipment which are to be employed during intense cold must be serviced with anti-freeze recoil fluid and lubricants.

CHAPTER 3

TRAINING AND MATERIEL

The training of infantry units stationed in Manchuria was primarily conducted according to the Military Training Manual of the Japanese Army. Because of its particular mission and operational planning, however, the Kwantung Army was obliged to issue supplementary instructions to the armies and other units under its command. This guidance dealt with especially important training requirements. Each army commander, in turn, instructed his divisions and border garrison units in accordance with the operational plans of the individual armies.

Within the Japanese Army, training could be classified as follows:



Company-grade officers were generally trained intensively and carefully, both in headquarters and in units, but field-grade officers (especially those above the rank of regimental commander) received comparatively brief training. Although training for battalion commanders was conducted prior to the China Incident, regimental commanders were not trained until thereafter. Despite the keenly appreciated necessity to train division commanders, such a program was

never instituted. During the campaigns in China, in fact, a number of division commanders merely parroted the tactical views of their staff officers. All in all, during the China Incident, a relatively large incidence of weakness in Japanese Army officer training was revealed.

The old system of military conscription called for three years' service by the individual enlisted man. This term was subsequently reduced by a year, and later by another two or three months, for a net period of service of only one year and nine or ten months.¹ Curtailment in the length of service was attended by a diminution in cadre training capabilities. As a result, the levels of training for enlisted men declined markedly, in contrast with the period when three years' service was required. These defects were brought to light during the China Incident.

Psychological Factors

Since the period of the Russo-Japanese War, the tradition of the Japanese Army was to lay great stress upon the fostering of spiritual factors in training; e.g., certainty of victory, and moral unity, in

1. Until 1907, all Japanese conscripts served three years. (See Photograph No.2). A term of two years was set for the infantry in 1907; for all arms except the cavalry in 1921; for the cavalry in 1922. Two to three months were lopped from the two-year term in 1926, with the establishment of thousands of Youth Training Centers (Seinen Kunrensho). - Ed.

PHOTOGRAPH NO. 2

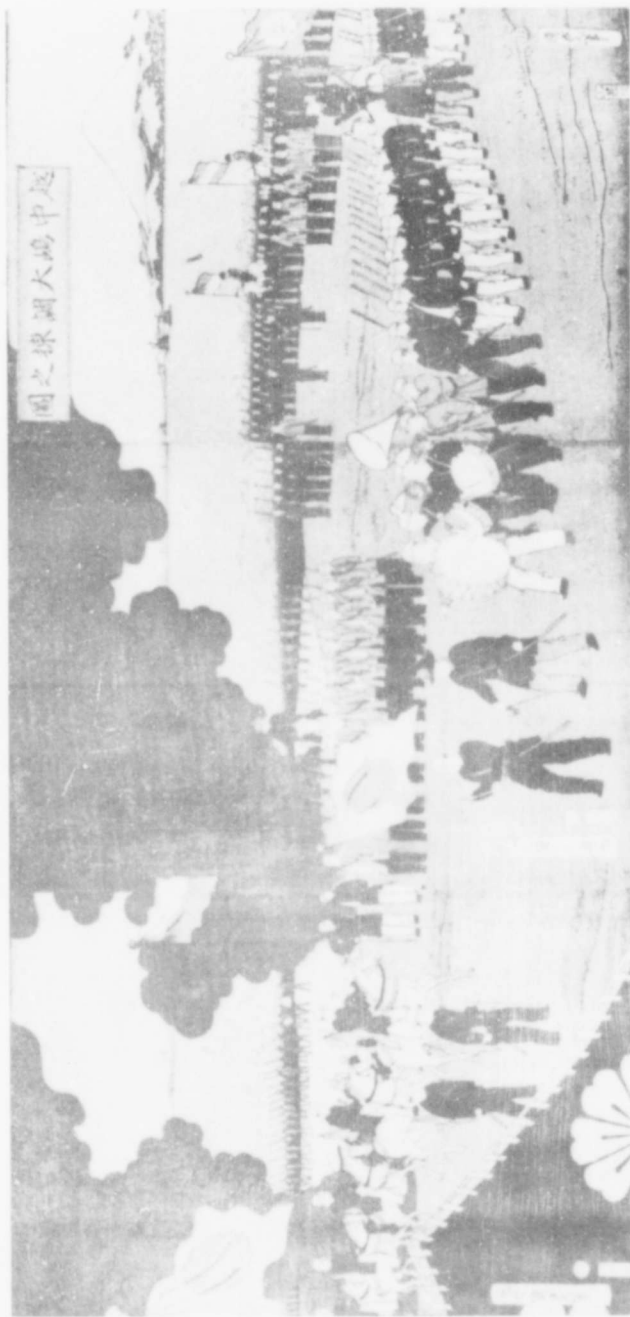

REPRODUCTION OF WOOD BLOCK

"EMPEROR MEIJI WAS PLEASED TO CONDUCT PERSONAL INSPECTION OF CLAN SOLDIERS IN TRAINING." ETCHUJIMA PARADE GROUND, 8 SEPTEMBER 1870. CLANSMEN TRAIN WITH MILITARY BAND; (FOREIGN, I. E. FRENCH ?) INSTRUCTOR GROUP CAN BE SEEN ON HORSEBACK.

particular. Infantry manuals stressed the need for thorough preparations, resolute execution of operations, firm conviction of success, doughty aggressive spirit, and firm cohesiveness. The precepts of the Japanese Army's Field Service Code (Senjinkun) are reproduced in Appendix B of the present study.²

Some of the young noncommissioned officers often misunderstood the demands of spiritual discipline, however, with the result that abuses ensued. For example, bodily punishments were meted out for the sake of so-called discipline—a practice which became the object of widespread fear and aversion on the part of the general public.

With the advent of the China Incident, new emphasis had to be devoted to training in the field, especially the prompt adaptation of combat lessons, and preliminary training for the succession of operations in the China theater.³

Combat Training

The Japanese Army's training year, which commenced in December and ended the following November, was divided into three phases:

- I: December-March
- II: April-July
- III: August-November

2. Also see Vol. XI, Japanese Studies on Manchuria, Book C, The Nomonhan Incident, Ch. 11, "Conflicting Philosophies." - Ed.

3. Training during the 1920's and 1930's had always stressed the hypothetical Soviet enemy, rather than the Chinese. After 1937, the nature of the actual Chinese enemy had to be taken into account to a greater extent. - Ed.

The training system was based upon General Staff mobilization planning, which was prepared in terms of the fiscal year (1 April-31 March). Recruits who completed Phase I of the training cycle, in March, were designated in the annual mobilization plan as "combat-ready" ⁴ soldiers.

When extended-formation tactics were adopted, the objective of the basic training system became the development of proficiency in individual combat techniques during Phase I, a goal which was largely met by the field units. In Manchuria, however, certain obstacles arose, such as time lags in conscription, and various weather problems (especially during the winter). As a consequence, Kwantung Army units were generally obliged to curtail the duration of their training cycles.

Company commanders in charge of recruit training drew up programs for each phase, in accordance with military training regulations. Squad, platoon, and company exercises were conducted mainly during Phase II, a four-month period commencing in the new recruit's fifth month of military service. These new men as well as the second-year soldiers participated in the Phase II exercises. Regulations required that company training be completed during this phase of the training cycle.

4. For detailed discussion of training programs, see Japanese Night Combat, Part 1, Chapter IV, p. 79ff. - Ed.

Exercises for units of battalion-size and above were scheduled for Phase III, the last third of the training year. Special instruction for artificers (such as blacksmiths, cobblers, and masons) was conducted concurrently, however, and this caused many complications and obstacles to combat training.

In the last weeks of Phase III, annual autumn maneuvers were conducted, involving infantry and supporting arms. Primarily centered upon the division level, these maneuvers were ordinarily preceded by exercises held by the regiments and brigades. Each individual training exercise lasted for several consecutive days. Since the days of the Russo-Japanese War, this entire period of Phase III was considered to be the most important annual training function of the Japanese Army.

The autumn maneuvers should have been a good time to test physical endurance and to provide field experience for commanders of all ranks. In practice, however, the exercises usually overemphasized mobile maneuver on the part of both the simulated attacker and defender. "Victory for victory's sake" was stressed throughout, at the expense of the practical exigencies of field combat tactics. This disregard for fundamentals tended to nullify the training inculcated during the successive phases of the basic cycle. Many weaknesses consequently resulted for both the line troops and the command.

Firing Techniques

From the standpoint of training, weapons fire was assigned top priority in planning and practice. The Infantry Firing Manual provided specific guidance, but "ideal" conditions were difficult to achieve because of expense as well as restrictions imposed by safety requirements. Terrain in the Japanese home islands was not suitable, in type or extent, for realistic, large-scale field firing by the infantry and supporting arms. Because of limitations imposed by the topographical features and constricted terrain in the Japanese home islands, it was almost impossible to conduct realistic, large-scale field firing which involved the infantry and its supporting arms. In Manchuria, however, many sites were well adapted to large-scale firing practice, which could therefore be carried out with great success for training purposes.

Weapons training was divided between basic range firing and field firing, the latter being further subdivided into individual, unit, and combined-arms field firing. After the term of compulsory military service was further reduced (from two years to only one year and nine or ten months), the Infantry Training Manual and the Infantry Firing Manual were drastically revised. The usual budgetary problems, however, prevented achievement of the desired training objectives. Thus, adequate training could not be conducted due to delay in the modification of firing ranges, while limits were simultaneously imposed on the number of rounds of training ammunition which could be expended.

5
Materiel

At the time of the Russo-Japanese War, the primary weapons of the infantry were the rifle and the bayonet but, by the end of that war, machine guns were beginning to make their appearance. During the following decades, weapons became more complex and diversified. When the China Incident broke out in 1937, the infantry was already equipped with a multiplicity of arms.

It is absolutely imperative that infantry be able to overcome any terrain encountered on the battlefield; minimize casualties even under the most severe bombardment; and expedite the combat movement of individual weapons. Limitations consequently have to be imposed upon the weight of man-portable arms, which must be dismantled for movement. The Japanese Army conducted extensive research into the problem and came up with numerous modifications and innovations in weapons design.

Since infantry always comprised the bulk of the Japanese ground forces, vast numbers of weapons had to be produced, at great cost to the national economy. Although, of course, the infantry would have wanted to be equipped throughout with latest-type materiel, problems inevitably arose in the manufacture and issue of new-model weapons

5. For preliminary discussion of infantry weapons, see Chapter 1 of the present study. - Ed.

6. The heavy machine gun, 70-mm. mortar, and 37-mm. gun (Model 11, 1922) were each normally borne by four men, but in an emergency could be carried by two. - Ed.

on such a large scale. The output of equipment could not therefore keep up with the latest advances in military technology, from the standpoint of national finances.

Rifle

Until World War II, most Japanese infantrymen were equipped with the Model 38, 6.5-mm. rifle, which dated back to the original basic version of 1905. In 1911 a short-barrel 6.5-mm. cavalry carbine (Model 44) was introduced. Neither weapon proved entirely satisfactory, in terms of range and killing power.⁷ A requirement was accordingly prescribed for a more effective ballistic projectile (7.7-mm.). The need for accuracy in aimed fire led to the design⁸ and issue of sniper rifles equipped with telescopic sights.

Coupled with the requirement for enhanced ballistic effectiveness was the need for an automatic rifle with a high cyclical rate of fire. In 1939 a ten-clip, 7.7-mm. Model 99 automatic rifle was designed and manufactured by the Army Ordnance Department. Ordnance tests were supplemented by winter trials of prototypes conducted by the Kwantung Army in Manchuria. It was intended eventually to furnish each infantry platoon with eight automatic rifles, and each company with 24; but Kwantung Army user units were never so equipped.

7. As indicated in Chapter 1, a 6.5-mm. sniper rifle, Model 97 (1937), also proved unsatisfactory in performance. - Ed.

8. A short-barrel 7.7-mm. sniper rifle, Model 99, was introduced in 1939. The author is referring to this weapon and to the 6.5-mm. Model 97, mentioned in the preceding footnote. - Ed.

The weapon had a maximum effective range of 600 meters, but Ordnance experts felt that the recoil was excessive for the average Japanese physique.⁹

Pistol

Pistol fire must be delivered rapidly, accurately, and trouble-free. Japanese Army service pistols underwent a considerable number of modifications and improvements in the years before World War II.¹⁰

Light Machine Gun

In order to simplify the ammunition problem, a light machine gun (Model 11, 1922) was designed which could use the same cartridge clip as the standard 6.5-mm. infantry rifle. The Model 11 suffered from inaccuracy and jamming, however, and was slated to be superseded by an improved version (Model 96, 1936).

Grenade Discharger

The Japanese Army successfully devised a light and simple grenade discharger to deliver high-angle fire at intermediate ranges. After the introduction of the original 50-mm. Model 10 (light) grenade discharger in 1921, a heavier version was designed, in order

9. Supplementary data provided by former-Maj. Gen. Matsushiro Ugaki in communication to editor, under date of 14 Nov 56, Okayama City. - Ed.

10. The old 9-mm. revolver of 1893 (Model 26) was followed by the Nambu series of 8-mm. pistols; e.g., the popular Model 14 (1925) and the Model 94 (1934). - Ed.

to provide increased range and effectiveness. Distributed to all user units, the new 50-mm. weapon (Model 89, 1929) displayed great ballistic versatility and performed excellently in the field.

Heavy Machine Gun

Based upon the lessons of the Russo-Japanese war, the 6.5-mm. Model 38 (1905) heavy machine gun was introduced. It became necessary to improve the precision, range, and effectiveness of this old weapon, however, and the 7.7-mm. Model 92 was eventually introduced in 1932. Air-cooled like its predecessors, the Model 92 was furnished with artillery-type sights and was an accurate weapon.

Antitank Defense

11.

An antitank rifle was designed for use by combat infantry, but it never proved effective during the Pacific War since its 20-mm. projectile was insufficient to penetrate the latest types of armor. A
12
47-mm. mobile gun was accordingly introduced, but although it represented a considerable improvement, it soon was rendered obsolescent by the advent of heavier armor and improvements in the metallurgical quality of steel plate. The decision was eventually reached to introduce a 70-mm. artillery-type antitank gun, but World War II ended before this weapon could be adopted.

11. Model 97 (1937) 20-mm. antitank rifle. - Ed.

12. Model 1 (1941) 47-mm. mobile gun. - Ed.

Regimental Gun

To meet the combat requirements of the infantry regiment, the 75-mm. mountain gun¹⁴ was initially adopted, but was subsequently re-modeled for specific field use. Studies were made of the possibilities of introducing tractors as prime movers, in order to facilitate mobile deployment of the gun batteries in combat, but the Pacific War ended before concrete results could be achieved.

Armored Tractors

The infantry faced acute difficulties in moving its heavy weapons and in hauling its ammunition and supplies under fire. It was therefore decided to design a light armored tractor which afforded protection against small-arms fire and which could be used by combat infantry. Plans were made to form company-sized independent tractor units within the infantry divisions, but World War II ended before these outfits could be organized.

13. The battalion gun is discussed in Chapter 1. - Ed.

14. Model 41 (1908) 75-mm. mountain gun. - Ed.

CHAPTER 4

FORTIFICATIONS AND LOGISTICS

Fortification Fundamentals

Mention has previously been made of the aversion of the Japanese Army to defensive operations in general and to fortification work in particular. Weaknesses in fortification capabilities were exposed in both the Russo-Japanese War and the China Incident. Fortification work seemed distasteful to the infantry, and they generally tended to consider it the duty of the engineers. In order to correct this slighting of fortifications, the Fortification Manual was revised, and a reference handbook entitled Infantry Fortifications was published as an expedient.

Developments in modern warfare--especially in terms of fire power, mechanization, and aviation--caused a transformation in modes of improved fortification. Appropriate training accordingly had to be stressed in the infantry program. Especially during peacetime, training in fortification work designed for offensive application had tended to be largely neglected, and was characterized by apathy when it was conducted at all. For example, when fortifications had to be dismantled or undone after training maneuvers, all ranks seemed to evince a great distaste for the work. Training authorities exerted great efforts in an attempt to rectify these weaknesses.

Offensive Fortifications

The Japanese Army distinguished between offensive fortifications (Kogeki Chikujo) and defensive fortifications (Bogyo Chikujo). The former were designed to cover preparations for offensive operations; to expedite attacks by keeping losses down; and to secure captured ground. There was always the danger, however, that fortifications of any kind might tend to discourage the attack spirit of the infantry or hamper their exploitation of opportunities by constricting the men in defensive works.

More detailed examination of the Kogeki Chikujo indicates that this type of fortification could serve a variety of combat and pre-combat defensive functions; e.g., when troops were: (1) assembling and concentrating for an attack; (2) manning forward security positions prior to an engagement; (3) moving forward during offensive combat (in which case construction work would be under the tactical command of the battalion); (4) securing captured positions in the course of attack operations; (5) gradually pushing forward during position warfare; or (6) readying positions for dawn attacks.

Defensive Fortifications

The concept and equipment of defensively fortified positions (Bogyo Chikujo) have undergone considerable change since the early 20th Century. Cover against armor and aviation have had to be stressed, as well as the development of defensive fire power and

of antitank protection. Elements which entered into the design and construction of defensive fortifications included concealment of works; provision for self-containment; minimization of damage; and protection against gas warfare and air attacks.

In the days of the Russo-Japanese War, defensive positions generally consisted of lateral fire trenches, connected in depth by communication trenches which led to the rear. The lessons of World War I and the changes in Soviet Army tactics eventually led to the introduction of a degree of tactical autarchy within the defensive fortification system. Individual defensive units were to be so equipped as to ensure self-containment within their positions, with emphasis devoted to the concealment of key sites by means of camouflage, cover, and dummy works.

Developments

During the Russo-Japanese War, individual soldiers took shelter within continuous lines of fire trenches, which also served as connecting trenches. With the transition to tactics involving extended formations and individual combat, foxhole-type construction came into use in order to afford cover to single foot soldiers. The exigencies of modern fire power and dispersed tactics also resulted in the use of covered trenches by groups of two or three soldiers; protection against chemical warfare might also be provided by such works. The old communication trenches now received more emphasis upon camouflage, concealment, and zigzagging, in order to cut down damage from

diversified and intense enemy fire. Many developments similarly took place in regard to the construction of shelters for signal and observation facilities.

Logistics

Unlike the situation in the days of the Russo-Japanese War, the infantry's growing organizational complexity and increase in the numbers and types of weapons and vehicles have rendered ground supply both complicated and difficult. At the turn of the century, logistical matters were considered to be the sole responsibility of the Transportation Corps, not of the infantry. Supply problems were consequently neglected, even during training. When the wartime organization of the entire Japanese Army was revamped after World War I, the problem of supplying the infantry was made the responsibility of that arm itself.

Ammunition Supply

The structure of Japan's national economy—natural resources, industries, and transportation capacity—forced the Army to conserve ammunition. Quantities of ammunition which could be expended during one ¹ engagement were generally fixed, and the amounts used as basic factors in resupply planning. To simplify computation, ammunition supplies for the various artillery pieces were described in terms of basic loads per

1. One "engagement" (a Japanese Army planning factor) denoted a period of about four months, to include movement, concentration, deployment, battle, and pursuit. Ammunition supply factors sufficient for one engagement were derived from calculations of national munitions capacity, in the light of lessons gained in the decades since the Russo-Japanese War.

2

engagement. The infantry setup was so complicated, however, that "basic loads" were impractical; rounds alone were designated instead, per single engagement. The relevant data for the principal infantry weapons follow: Rifle--350 rounds; light machine gun--7,000 rounds; heavy machine gun--15,000 rounds. A breakdown of the ammunition supplies carried by various units, in terms of one engagement's duration, is given in Table 2.

More of the ammunition for small-caliber weapons was up front than at the rear. In the case of artillery, ammunition field supply was rendered difficult by the fact that most of the shells were carried by rear echelon units, regardless of the quantities available.

Mention was previously made that ammunition loads for individuals and field units varied with the weapon, and that Army supplies were generally limited. As a consequence, rationing frequently had to be imposed and the elimination of wasteful expenditures was stringently emphasized. For example, in order to conserve ammunition, the regimental commander would set up a utilization plan and disseminate it among the battalion commanders. Based upon this schedule, the individual battalion commanders issued appropriate instructions to the

2. In Japanese Army usage, basic loads for artillery pieces comprised the following: 75-mm. gun--100 rounds; 10-cm. gun--50; 15-cm. gun or howitzer--30. - ibid.

Table 2
Ammunition Loads
(Percentages per Engagement)

	Unit*	Ammo Flat	Div Trans Unit	Fld Ord Dump
Rifle	32	20	15	33
IMG	15	30	55	
Bn Gun	15		50	35
AT Gun	50		30	20
* Refers to individual soldier in case of rifle only.				

company commanders who, in turn, established allocations for the component platoons. Platoon and squad leaders were to conduct operations with economy of ammunition consumption strictly in mind. Not only was the stock of shells rationed on occasion, but unit commanders sometimes went so far as to designate specific gunners known to exercise economy of fire.

As a rule, the ammunition bearers took their places behind the gunners as members of relay teams responsible for ammunition resupply of the individual guns. The end-man in the relay system picked up his supplies from the dumps established by the ammunition platoons. Dumps were ordinarily located at a considerable distance to the rear of the firing positions. Reserve troops or ammunition platoon pack horses therefore had to be used to haul the ammunition to the front. Considerable time was inevitably consumed in the process; very often ammunition could not be delivered to the combat units in the desired quantity or time. It eventually became necessary to resort to the use of motor vehicles, whose speed facilitated prompt and large-scale transportation, even under fire.

Rear Supply

The flow of ammunition to units behind the front lines (e.g., regiments and below) was the responsibility of divisional transport regiments and field ordnance dumps. A division commander would move up his transport regiment's infantry ammunition company to a pre-selected

point where an ammunition dump would be set up for the front-line units. Conditions permitting, the ammunition company would advance even further to a site immediately behind the front and establish distribution points for resupply. In such cases, nearness to the front is important, although distances to the rear must simultaneously be taken into consideration.

Rations and Forage

Provisions for the sustenance of men and animals could be classified into three categories: individual, unit, and rear echelon. These supplies were ordinarily adequate to sustain men or horses for five days. Specific allocation factors are summarized in Table 3, in terms of the number of days. The individual soldier's provisions were meant to be consumed only in case of emergency, the usual procedure being the utilization of unit rations and forage supplies. Required provisions were usually sent forward from the rear on a constant basis.

Large parts of Manchuria are barren, and local procurement of food or forage is nearly impossible. In the eventuality that operations were to be launched deeply into enemy-held territory, provisions would have to be stockpiled in sufficient quantities prior to the action. This necessity would become especially acute when the combat units involved must be supplied far from the roads.

Ordnance

The repair and maintenance of infantry weapons, and the supply of lubricants, etc., are of great importance in the field. Repair work and the replacement of unserviceable parts must be carried out quickly and expeditiously. Japanese Army units carried spare parts for every infantry weapon, but the regulations called for the dispatch of all ordnance equipment to field depots for repairs, whether major or minor. Experience in the Manchurian Incident and the China Incident frequently indicated, however, that this procedure was both time-consuming and inconvenient. The infantry companies therefore adopted the practice of providing ordnance repair teams, consisting of several artificers each, to effect simple repairs even during battle.

Table 3
Allocations of Provisions
(in days)

Type	Soldier's Rations	Horse's Forage
Individual	2	1
Unit Train	1	2
Transportation Regiment	2	2
TOTAL	5	5

Appendix A

JAPANESE ARMY DEFENSIVE CONCEPTS*

"Japanese attitude. The defensive form of combat generally has been distasteful to the Japanese, and they have been very reluctant to admit that the Imperial Army would ever be forced to engage in this form of combat. So pronounced has been their dislike for the defensive that tactical problems illustrating this type of combat are extremely rare.

"Object. The object of the defensive is to inflict on the superior hostile forces such losses by fire power, disposed appropriately on the terrain and behind man-made defensive works, that the initial disparity of forces becomes equalized to the point of authorizing a passage eventually to the offensive.

"Doctrine. The old Combat Regulations (Sento Koyo), superseded in November 1938, based discussion of the defensive on the active defense. The newer regulation (Sakusen Yomurei) takes the passive defense, assumed in the presence of overwhelmingly superior forces, as the typical case, of which the active defense is a variant calling for special discussion. This latter viewpoint is definitely contrary to former practice where a return to the offensive is always present in the plans for the defense, even though the initial disposi-

* Based upon excerpts from Handbook on Japanese Military Forces, U.S. War Department Technical Manual TM-E 30-480 (15 Sep 44), Unclassified, p. 99ff. - Ed.

tions are not those of an active defense in the true tactical sense of the word. This indicates a change in official emphasis, but probably means no real change in the practice of the defense, since in actual combat and in illustrative problems there is always present the characteristics of active defense. ...

"Conduct of the defense. The counterattack or counteroffensive.

The division commander is constantly on the alert to determine the proper time for the division counterattack or counteroffensive. The favorable moment will generally be at the time the hostile attack has been stalled; when the enemy has blundered into an unfavorable position; when a favorable opportunity has been created by a successful local counterattack; and when the enemy pauses to reorganize or consolidate his position. The plan for a return to the offensive will be made tentatively, well in advance of the occurrence of the opportunity. The direction of the counterattack generally will be aimed at an envelopment; however, at times, the situation may compel a purely frontal attack. The mass of artillery, and tanks if present, will support the counterattack or counteroffensive. The division commander may directly control the counteroffensive, or he may delegate control to a sector commander.

"Comments. Aggressive character. Since the defensive in Japanese regulations and military writings is branded as a negative form of combat, un-Japanese in essence and spirit, it has been very difficult to write a tactical problem for which officers were willing

to advocate a defensive solution. In problems studied, the basic decision to defend already had been made by the division commander, a school device to control the offensive plan of the student officers. Even when thus forced on the defensive, Japanese officers have the return to the offensive always uppermost in their minds and are quick to launch counterattacks, large and small, coordinated and uncoordinated, on the slightest provocation. On the maneuver ground, troops are always ready to abandon their prearranged system of infantry fires to meet the attacker with the bayonet in front of their trenches. The defects of a defense so conducted are glaring to the occidental student of tactics, but its positive and aggressive character has virtues which will, on occasions, upset a careless or overconfident attacker."

Appendix B

FIELD SERVICE CODE (SENJINKUN)*

INTRODUCTION

The battlefield is where the Imperial Army, acting under the Imperial command, displays its true character, conquering whenever it attacks, winning whenever it engages in combat, in order to spread KODO far and wide so that the enemy may look up in awe to the august virtues of His Majesty. Those who march to the battlefield, therefore, should endeavour to exalt throughout the world the glories of the Empire by fully realizing what the country stands for and firmly upholding the moral tenets of the Imperial Army.

The Imperial Rescript to the armed forces is explicit, while the regulations and manuals clearly define conduct in combat and methods of training. Conditions in the zone of combat, however, tend to cause soldiers to be swayed by immediate events and become forgetful of their duties. Indeed, they should be wary there lest they run counter to their duties as soldiers. The purpose of this code lies in providing concrete rules of conduct, in the light of past experience, so that those in zones of combat may wholly abide by the Imperial Rescript to enhance the moral virtues of the Imperial Army.

* Adopted by the Japanese Ministry of War, 8 Jan 41.

CHAPTER I

1. The Empire

Japan is the KOKOKU. The TENNO rules over it everlastingly in a line unbroken through the ages as the successor in the high and broad cause established by the Imperial ancestor at the time of the founding of the Empire. Imperial benevolence is extended to all without favor, while the Imperial virtues enlighten the world. The people, too, handing down the traditions of loyalty, filial piety and valour from generation to generation, and enhancing thereby the morality peculiar to the Empire, have assisted the Throne, a perfect national unity under the Throne, which has brought about the present national prosperity.

Soldiers on the field should seek to achieve, with unshakable determination, their mission of defending the Empire by laying to heart the essential character of the national policy.

2. The Imperial Way

The Army, under command of the Emperor, assists in furthering the Imperial fortunes by enhancing the glories of the Empire through the embodiment of the lofty spirit of valour. This spirit is the basic factor in realizing universal peace; for it is the spirit of justice combined with valour and of valour tempered by benevolence, in conformity with the Imperial wishes. Valour requires strictness, while benevolence must be universal. Should there be an enemy who dares to oppose the Imperial Army, the army must resolutely resort

to force of arms and deal him a crushing blow. However, even though force may compel the enemy to submit, should a lapse in virtue occur by striking those who do not resist or by failure to show kindness to those who surrender, it cannot be said that such an army is perfect.

Modest in its strength, unostentatious in its kindness, the Imperial Army becomes an object of admiration when it quietly displays its valour and benevolence.

The mission of the Imperial Army lies in making the Imperial virtues the object of admiration through the exercise of justice tempered with mercy.

3. Discipline

The essence of discipline in the Imperial Army lies in the lofty spirit of obedience to His Majesty, the Generalissimo. High and low must have deeply engraved in their minds the solemnity of the right of command; those above should exercise the right in all seriousness while those below should obey the commands in the utmost sincerity. Essential to victory and requisite for maintaining peace is the condition wherein the entire Army, united in the bonds of absolute loyalty, moves as one in response to a command.

Especially on the battlefield is the utmost observance of the spirit of obedience necessary. The spirit of the soldier is best exemplified by those who silently do their duty, joyfully braving death

in obedience to a command given at a time when they are undergoing great hardships.

4. Unity

The Army looks up in awe to His Majesty as its august head; it must be united in compliance with the Imperial Will, as one in spirit and in body and in single-hearted loyalty.

In keeping with the basic principles of command, an army unit should form a solid yet genial group with its commander as its centre.

It is essential that each man, high and low, dutifully observing his place, should be determined always to sacrifice himself for the whole, in accordance with the intention of the commander, by reposing every confidence in his comrades, and without giving even the slightest thought to personal interest and to life or death.

5. Cooperation

Soldiers should not only be united in mind in carrying out their tasks, but should display the spirit of cooperation by forgetting themselves for the sake of victory.

Every unit should carry out its mission with responsibility, upholding its honour, placing confidence in others and assisting one another, volunteering to face hardships, exerting all its strength in cooperation, and fighting valiantly to achieve its objective.

6. Aggressiveness

Aggressiveness should constantly prevail in combat, which must be carried out with bravery and determination. When attacking be determined and positive, always taking the initiative, fighting vigorously and stubbornly vowing not to cease until the enemy is crushed. In defense, always retain the spirit of attack and always maintain freedom of action; never give up a position but rather die. In pursuit, be thorough and inexorable.

Act boldly intent upon victory; be fearless and calm, meeting the situation courageously, undergoing hardships with indomitable perseverance so as to overcome all obstacles.

7. The Conviction to Win

Faith is strength. He who has faith in combat is always the victor.

The conviction to win grows from constant and rigorous training. Develop the strength to conquer the enemy by every possible effort and by improving every moment.

The destiny of the Empire rests upon victory or defeat in battle.

Do not give up under any circumstances, keeping in mind your responsibility to keep untarnished the glorious history of the Imperial Army with its tradition of invincibility.

CHAPTER II

1. Piety

The Gods look upon us from above.

Be worthy of divine protection by being pure in heart, just in action, profound and sincere in your piety, constantly mindful of the loyalty you owe to the Emperor and of your duty to your parents.

2. Filial Piety

Loyalty and filial piety, as one, form the essence of our morality; a loyal subject is always a dutiful son.

Endeavor to manifest the best traditions of our forefathers by bearing in mind the wishes of your parents, thereby fulfilling the sacred duty of a loyal subject on the battlefield.

3. Salutes and Manners

The salute is the expression of a sincere feeling of obedience and is also a symbol of unity between those above and those below.

Salutes must be strictly executed on the field. If a soldier is filled with the sense of decorum and is strict in practising good manners, it shows that he is a strong warrior.

4. The Way of Comrades in Arms

Comrades in arms, united in life and death for the Imperial cause, should display full mutual trust, should always endeavor to improve each other; assist each other in distress, and restrain

each other in excess, in order that they may jointly fulfill their duty as soldiers.

5. Initiative in Exemplary Conduct

Leaders should be zealous in giving a worthy example in everything. If there is disorder above, those below will be unruly.

Action is prized on the field. Leaders should provide an example by acting more courageously than others.

6. Responsibility

Duty is sacred. One's responsibility is extremely heavy. Each and every task must be performed with utmost care, until all available means are exhausted. Those who have a strong sense of responsibility are the bravest of the brave on the field.

7. View of Life and Death

The lofty spirit of self-sacrificing service to the State must prevail in life and in death.

Do your duty with heart and soul, regardless of life or death. After exerting all your powers, spiritually and physically, calmly face death, rejoicing in the hope of living in the eternal cause for which you serve.

8. Honour

Strong are those who have a keen sense of honour.

Meet the expectations of your family and home community by making effort upon effort, always mindful of the honour of your name. If alive, do not suffer the disgrace of becoming a prisoner; in death, do not leave behind a name soiled by misdeeds.

9. Simplicity and Fortitude

Let simplicity guide your daily life on the battlefield; promote habits of fortitude and a high morale.

Life on the field must be plain; consider privation your daily lot and endeavour to be thrifty; luxury saps valour.

10. Integrity

Integrity is the foundation of the spirit of the warrior. How can a man who cannot conquer desire to devote his life to his country?

Be austere in your daily behaviour; deal with matters justly so that you will not be ashamed of your conduct in the sight of God or man.

1. Counsel Concerning Field Service

(1) A moment's negligence may result in an unexpected catastrophe. Be constantly on your guard. Do not despise your enemy or the natives. Do not be negligent after a small success. Know that carelessness brings disaster.

(2) Sentry duty is important. Upon the sentry rests the safety of an army; he also represents the discipline of an army. Those on sentry duty must devote their person to their tasks which must be sternly carried out. Accord the sentry high respect.

(3) Ideological warfare is an important phase in modern conflict. Destroy propaganda and fabrications of the enemy by your unshakable faith in the cause for which your Empire stands, and endeavour to spread KODO.

(4) Rumours arise from a lack of confidence. Do not be misled; do not be agitated by them. Firmly believe in the strength of the Imperial Army and deeply trust your superiors.

(5) Be mindful to protect enemy property and resources. Requisitions, seizures, and the destruction of goods and similar actions must be executed in keeping with the regulations and always under the order of your commanding officer.

(6) Be gentle to and protect innocent inhabitants in a spirit of benevolence, in accordance with the true ideals of the Imperial Army.

(7) Those in the field must not indulge in wine and women or allow desire to becloud their conscience thereby damaging the prestige of the Imperial Army and causing the dissipation of a body dedicated to service. They should exercise self-control lest they besmirch the pure character of warriors.

(8) Control your anger and suppress your grudges. The ancients said, "Consider anger your enemy." A moment's violence often leaves cause for a long regret.

The severity of military law is designed especially to uphold the good name of soldiers and to preserve the dignity of the Imperial Army. Always remember the oath that you made and the deep emotion that you felt when you left home; call to mind how your parents, your wife and your children think of you, and avoid exposing yourself to crime.

2. Achievements of Soldiers in Service

(1) Foster the tradition of respecting martial attainments; cultivate and train the warrior's virtue and arts. Remember that "Do not allow yourself to become bored" is the saying of an ancient general.

(2) Do not allow yourself to worry about the fate of those at home in the event of your death, but devote yourself wholly to service. Be always ready to meet death without regret by settling your affairs beforehand.

A soldier is always prepared to expose his corpse in the field. Let his family know that, at times, even his ashes may not reach them.

(3) There is nothing more to be regretted than to fall a victim to disease in the field. Be particularly mindful of your health so that you may not be unable to serve because of excesses.

(4) Lay to heart the saying of an ancient warrior: "My sword is my soul; my horse is my fortune." Always take good care of your arms and supplies and give humane attention to animals in the field.

(5) Virtue in the battle zone is the source of strength in combat. Always consider the interest of other units and do not monopolize billets and materials. Remember the saying "A bird taking flight does not muddy the water." Let the good reputation of the valorous Imperial Army long remain in the cause of good recollections in an alien land.

(6) Not to boast of one's achievements but to give others credit is one of the most respected traditions among warriors. Do not begrudge others their promotion or cherish resentment because your services are not recognized, but instead reflect upon your own shortcomings.

(7) Be honest always; consider exaggerations and lies as dishonourable.

(8) Always bear yourself as a member of a great nation, treading the path of righteousness and seeking justice, so that you may enhance the prestige of the Empire. Also do not show a lack of consideration for international courtesies.

(9) Should you receive the order to return home alive after braving ten thousand deaths, think of those brave souls who will not return. Be determined to become an example to the people by being careful in word and deed, renewing your vows to serve the country.

Conclusion

All of the above originate from, and end in, the Imperial Rescript. Let them serve as a guide in putting into practice this battlefield morality so that all may be perfect in obeying the Imperial commands.

Soldiers and officers in the field: lay to heart the import of the above by fully realizing the significance of real service to the State, in order that you may carry out your duty as soldiers, thus responding to the boundless Imperial benevolence.

* * * * *

KODO—Literally, "The Imperial Way," whereby the Japanese people, achieving a unity of mind, with the Emperor as Master and serving Him with loyalty and devotion, endeavour to establish a highly moral nation through whose moral influence they hope to contribute to the peace and welfare of the world.

KOKOKU—Empire or the land of TENNO.

TENNO—The Emperor of Japan.

INDEX

- Anti-Soviet Army Combat Tactics
("Red Books"): 53n, 62
- Armies, Japanese Army
Formosa: 3
Kwantung: 11, 26, 77, 82, 86
- Army Ordnance Department, Japanese Army: 86
- Bangalore torpedo: 40
- Changkufeng Incident: 49, 58
- Chiba Infantry School: 3
- China Incident: 11, 32, 36, 41, 49, 57-58, 61, 66, 77-78, 81, 85, 91, 100
- Continent, Asiatic: 66
- Division, Japanese Army
16th: 53
- Dogs: 31
- Engagement (Japanese Army planning factor): 95n-96n. See also Table 2.
- Field Service Code (Senjinkun): 81, 107-19
- Field Service Regulations, Japanese Army: 47, 51-58
- Hotchkiss weapons: 17n
- Imperial Rescript: 107
- Infantry Firing Manual, Japanese Army: 84
- Infantry Fortification Manual, Japanese Army: 91
- Infantry Training Manual, Japanese Army: 47, 52, 64n, 84
- Ishihara, Lt. Gen. Kanji: 53
- Kanchatzu Incident: 49
- Manchurian Incident: 20, 30, 45, 58
- Military Training Manual, Japanese Army: 77
- Mobilization planning, Japanese Army: 82
- Nambu: 19n, 87n
- Napalm: 71
- Nogi, Gen.: 35n
- Nomonhan Incident: 49, 60
- Okayama City: 87n
- Pacific War: 11-12, 14, 17, 39, 39n, 40, 49, 54, 59-60, 88
- Regiments, Japanese Army
1st Inf, Guard Division: 35n
2d Inf, Guard Division: 35n
- Russo-Japanese War: 13-14, 19, 21, 29, 29n, 35, 35n, 41, 52, 55, 58, 60, 62, 78, 83, 85, 88, 91, 93, 95, 95n
- Sakusen Yomurei: 103
- Satsuma Rebellion: 35n
- Senjinkun. See Field Service Code.
- Sento Koyo: 103
- Term of service, Japanese Army: 78n
- Tochka (pillbox): 22n, 53
- Ugaki, Maj. Gen. Matsushiro: 3, 87n
- Weapons, Japanese infantry
Model 26 (1893) 9-mm. revolver: 87n
Model 38 (1905) 6.5-mm. HMG: 29n, 88
Model 38 (1905) 6.5-mm. rifle: 19n, 86
Model 41 (1908) 75-mm. mountain gun: 36n, 89n
Model 44 (1911) 6.5-mm. cavalry carbine: 86
Model 3 (1914) 6.5-mm. HMG: 29n
Model 10 (1921) 50-mm. grenade discharger: 20n, 87
Model 11 (1922) 37-mm. gun: 30n, 85n
Model 11 (1922) 6.5-mm. LMG (Nambu): 19n, 87
Model 11 (1922) 70-mm. mortar: 20n, 30, 85n
Model 14 (1925) 8-mm. pistol: 87n
Model 89 (1929) 50-mm. grenade discharger: 20n, 88
Model 92 (1932) 7.7-mm. HMG: 29n, 88

Weapons, Japanese infantry (contd.)

Model 92 (1932) 70-mm. howitzer:

30n

Model 94 (1934) 8-mm. pistol:

87n

Model 94 (1934) 37-mm. rapid

fire gun: 26n

Model 96 (1936) 6.5-mm. LMG:

19n, 87

Model 97 (1937) 20-mm. AT rifle:

17n, 86n

Model 97 (1937) 6.5mm. sniper

rifle: 19n, 86n

Model 99 (1939) 7.7-mm. automatic
rifle: 86

Model 99 (1939) 7.7-mm. LMG: 19n

Model 99 (1939) 7.7-mm. sniper
rifle: 19n, 86n

Model 1 (1941) 47-mm. mobile gun:
26n, 88n

World War I: 11, 29-31, 39, 41, 52,
57, 93, 95

World War II: 3, 12, 50, 86-89

Yano, Col. Muraji: 3

Youth Training Centers, Japanese:
8n