

PHOTOGRAPH THIS SHEET

7

INVENTORY

LEVEL

AD-A953 888

DTIC ACCESSION NUMBER

WAL-642/113

DOCUMENT IDENTIFICATION

DISTRIBUTION STATEMENT A

Approved for public release; Distribution Unlimited

DISTRIBUTION STATEMENT

ACCESSION FOR

NTIS GRA&I

DTIC TAB

UNANNOUNCED

JUSTIFICATION

BY

DISTRIBUTION /

AVAILABILITY CODES

DIST

AVAIL AND/OR SPECIAL

A-1



AT-39463

DTIC ELECTED  
OCT 19 1984  
S D

DATE ACCESSIONED

DISTRIBUTION STAMP

UNANNOUNCED

DATE RETURNED

84 10 12 075

DATE RECEIVED IN DTIC

REGISTERED OR CERTIFIED NO.

PHOTOGRAPH THIS SHEET AND RETURN TO DTIC-DDAC

RESTRICTED

# UNCLASSIFIED LABORATORY



INDEXED

AD-A953 888

Report No. 642/113

### ARC WELDING OF ARMOR

Test of Five H Plates - 1 Inch Thick Rolled Homogeneous Armor  
Welded with Plain Carbon, Low Alloy, and Medium Alloy  
Ferritic Electrodes at Watertown Arsenal

by

S. A. Herres  
1st Lt., Ordnance Department

and

W. L. Warner  
Senior Welding Engineer

March 20, 1943

WATERTOWN ARSENAL  
WATERTOWN, MASS.

# UNCLASSIFIED

RESTRICTED

642/113

# DISCLAIMER NOTICE

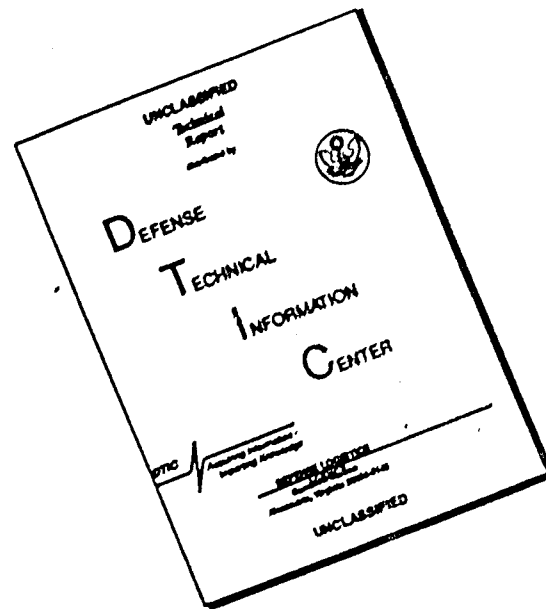

THIS DOCUMENT IS BEST QUALITY AVAILABLE. THE COPY FURNISHED TO DTIC CONTAINED A SIGNIFICANT NUMBER OF PAGES WHICH DO NOT REPRODUCE LEGIBLY.

Warner/ahk

April 7, 1943

W.A. 470.5/3814  
 Laboratory (LV)

*Miss Morgan  
 Robert File*

Subject: Watertown Arsenal Report No. 642/113

To: Chief of Ordnance, U. S. Army  
 Washington, D. C.

Attn: Technical Division - Service Branch

1. Inclosed herewith are six (6) copies of Report No. 642/113, entitled "Arc Welding of Armor - Test of Five H Plates - 1 inch Thick Rolled Homogeneous Armor Welded with Plain Carbon, Low Alloy, and Medium Alloy Ferritic Electrodes at Watertown Arsenal."

2. These reports are for distribution as follows:

- 1 copy - SPOIR
- 1 " - SPOTR
- 3 copies - SPOEB, Technical Reports.

One copy is to be filed in the Ordnance Technical Library, and index cards are inclosed for that purpose.

3. Copies of this report have been sent to Rock Island Arsenal, Aberdeen Proving Ground, Tank-Automotive Center, and National Research Council (Welding Supervisor).

4. This investigation covers a ballistic check test of five welded H plates, of substandard size, to obtain data on performance of butt joints in 1 inch rolled homogeneous armor welded with plain carbon and low alloy ferritic electrodes. The low hardness and inferior physical properties (with respect to those of the plate) of the plain low carbon weld deposits result in inferior ballistic performance which is not materially improved by post heat treatment below the critical (1000° F. for 3 hours, air cool). The addition of small amounts of alloy (.25% Mn, .35% Ni) results in improved ballistic performance under check.

For the Commanding Officer:

**E. E. Koenig**  
 Colonel, Ordnance Dept.  
 Director of Laboratory

2 Incls.  
 Report No. 642/113 (6 copies)  
 Index cards

*W.A. 470.5/6438 (2)*

DISTRIBUTION OF REPORTS

REPORT NO. 112

DATE DISTRIBUTED \_\_\_\_\_

NO. OF COPIES 6

Author

Lab. File

Main Office File

Chief of Ordnance

Springfield Armory

Watervliet Arsenal

Rock Island Arsenal

Frankford Arsenal

Picatinny Arsenal

Aberdeen Proving Ground

Extra Copies - 1

Other establishments requesting work.

1 - *see red ink*  
 1 - *SPS 118*  
 1 - *SPS 118*  
 3 - *Dept Sect*  
 1 - *SPS 118*  
 2 *copies to [unclear] - 11/11*  
 1 *copy to [unclear]*  
 1 - *copy to [unclear] - 3/25/44*

*[Handwritten signature and notes]*  
 [unclear]  
 [unclear]

# UNCLASSIFIED

ARC WELDING OF ARMOR

March 20, 1943

Test of Five H Plates - 1 Inch Thick Rolled Homogeneous Armor  
Welded with Plain Carbon, Low Alloy, and Medium Alloy  
Ferritic Electrodes at Watertown Arsenal

## OBJECT

To carry out ballistic shock test and metallurgical examination of subject plates in order to compare the shock resistance of joints welded with the three electrodes and to determine whether a post heat treatment of the plate results in any improvement of shock resistance of the welded joints.

## SUMMARY OF RESULTS

1. The low hardness and inferior physical properties of weld deposits made with plain low carbon electrode result in inferior ballistic performance which is not materially improved by post heat treatment below the critical (1000° F. for 3 hours, air cool).

2. The improved weld metal properties of joint made with low alloy (.40% Mn, .38% Mo) electrode result in somewhat improved ballistic performance. Post heat treatment of welded plate (1000° F. for 3 hours, air cool) which tempers excessively hardened structure of plate metal adjacent to root and crown beads and which may to some extent relieve residual stress across welded joint, improves resistance of this type joint to ballistic shock .

3. It is indicated that a joint made with medium alloy (2.17% Mn, .85% Si, .13% Cr, .30% Mo) and welded with suitable technique to avoid excessive weld hardening of plate metal may result in a satisfactory type of ferritic joint.

*S. A. Herres*  
S. A. Herres  
1st Lt., Ordnance Dept.

*W. L. Warner*  
W. L. Warner  
Sr. Welding Engineer

APPROVED:

*[Signature]*  
H. H. Zornig  
Colonel, Ordnance Dept.  
Director of Laboratory

# UNCLASSIFIED

## INTRODUCTION

The tests described in this report represent an attempt to obtain data in answer to the following questions:

1. Do joints welded in armor with commercial types of covered plain low carbon ferritic electrodes have satisfactory resistance to ballistic shock?
2. What benefit may be obtained by adding small and medium amounts of alloy to low carbon weld metal?
3. Does a draw treatment after welding have any effect on the ballistic shock performance of low alloy ferritic weld metals?

The size of the H plates used for the test was substandard because of limitations of test range facilities. The results, however, are believed to be comparable. The number of H plates was limited by the quantity of armor plate of the same type composition and processing available for these tests.

## TEST MATERIALS

The armor used in making up the H plates for these tests was 1 inch thick rolled homogeneous, made by the Great Lakes Steel Corporation, and heat treated by Simonds Saw and Steel Company. Chemical composition of the plate was approximately:

<u>C</u>	<u>Mn</u>	<u>Si</u>	<u>Cr</u>	<u>Mo</u>	<u>S</u>	<u>P</u>	<u>Zr</u>
.28%	.85%	.55%	.70%	.21%	.026%	.028%	.06%

Plate was quenched and drawn to an approximate hardness of 310 Brinell.

The welding electrodes used were: Chemical Composition of Weld Deposit\*

<u>Type</u>	<u>Trade Name</u>	<u>C</u>	<u>Mn</u>	<u>Si</u>	<u>Cr</u>	<u>Mo</u>	<u>Ni</u>	<u>Ti</u>
Covered Plain								
C Ferritic	Murex Fillex	.06	.55	.17	---	---	---	---
Covered Low	Lincoln Shield							
Alloy Ferritic	Arc. No. 85	.08	.40	.15	.04	.38	Nil	Nil
Covered Medium	Arcos Manganend							
Alloy Ferritic	2 MS	.13	2.17	.85	.13	.30	Nil	Nil

\* Chemical analyses made on pads of weld metal deposited on mild steel plate according to American Welding Society A.S.T.M. Specification A233-42T, to give a weld deposit unadulterated by plate metal.

## TEST PROCEDURE

### Welding and Heat Treatment

H plates were welded as follows:

<u>Plate</u>	<u>Electrode</u>	<u>Post Heat Treatment</u>
HF-1	Plain low carbon	None
HF-2	" " "	Crossbar cracked - rejected without ballistic test
HF-3	" " "	1000° F. for 3 hours, air cool
H85-1	Low alloy	None
H85-2	" "	1000° F. for 3 hours, air cool
HM-1	Medium alloy	None

The parts for the H plates were flame cut with a 30° bevel after pre-heating to 400° F. by heating torch operated manually (temperature checked by Tempil pellets), and the cut surfaces were lightly ground to remove any excess scale and irregularities due to cutting.

Details of welding are given in Appendix A which includes a table of all welding data and two sketches showing sequence and deposition technique of welding.

Each plate was assembled by strapping to a cast iron platen. A root opening of 1/4 inch with the 60° single V joint backed up by a carbon steel strip 1/4 x 1-1/4 inch (see Fig. A, Appendix A) was used. All welding was carried on with the armor preheated to a temperature of 125° to 175° F. The two leg welds of each H plate were completed before starting to weld the crossbar. The plate was allowed to cool to approximately the 125° to 175° F. range between passes on all welds.

Post heat treatment was carried out on two plates by furnace heating for 3 hours at 1000° F. followed by an air cool.

### Radiographic Examination

Following welding, the crossbar weld of each H plate, together with a 9-inch portion of each leg weld adjacent to the junction, was radiographed to determine whether any cracks and lack of fusion or incomplete penetration were present. The welds examined were found to be free from these defects.

It should be pointed out here that the second H plate welded with the low carbon electrode (HF-2), developed a crack in the crossbar weld upon completion. There is no apparent reason which can be suggested for this occurrence since both HF-1 and HF-3 were welded similarly and no cracks developed after welding.

### Ballistic Shock Tests

The plates were tested at the Watertown Arsenal 100-yard range with plates normal to the line of fire. T.P. M51 37 mm. projectiles were used.

642/113

Hits were aimed for the leg welds 3 inches above and below the crossbar intersection.

### Metallurgical Examination

Following ballistic testing, plates were photographed for visual examination and a section was taken through each crossbar weld by abrasive wheel cuts for macro, hardness, and microexamination as detailed below.

## DATA AND DISCUSSION

### Ballistic Test Results

The results of ballistic shock tests are given in Table I. These tests were made on substandard (18 x 18 x 1 inch) H plates with a 37 mm. test projectile. Since the velocities and locations of projectile impacts varied somewhat from plate to plate, it is necessary to make allowance for the severity of shock test in drawing comparisons among the five plates tested.

No data are available for comparison of these results with similar plates welded with austenitic electrodes. However, the higher velocity of testing, 2000 f/s, represents a fair test for virgin armor of this thickness and would be expected to differentiate between satisfactory and poor welding procedures with austenitic electrodes. The scope of these tests was limited to a comparison of ferritic electrodes in order to indicate the most promising avenues for future tests and comparison with austenitic electrodes on standard H plates,

### Visual Examination

Figures 1 through 10 are photographs of front and rear of each plate after ballistic testing.

### Macroexamination

Figure 11 is a photograph of cross section of welded joint from each of the five H plates as prepared for macroexamination and hardness survey. These specimens were taken through center of horizontal crossbar of each H plate.

Macrophotographs illustrate degree of elimination of heat-affected structures in the two specimens which were subjected to the post heat treatment of 1000° F. and air cool. Specimen welded with Arcos Manganend electrode is seen to have a relatively narrow root opening and rather sharp definition of heat-affected zones in plate metal bordering the weld.

### Hardness Surveys

Vickers-Brinell hardness readings across top, center, and bottom of weld cross sections are plotted in Figs. 12 through 16.

Figure 12 represents hardness survey of joint welded with plain low carbon ~~Murax~~ Fillex electrode. Maximum hardness in heat-affected zone of plate was approximately 355 Vickers-Brinell, as compared with a plate metal hardness of approximately 310 and weld metal hardness ranging from 145 to 210.

Figure 13 represents hardness survey of joint similar to the above, except that it was subjected to a post heat treatment at 1000° F. for 3 hours with an air cool. The hardness of the heat-affected zone of plate has been lowered only slightly by this treatment, and the hardness range of the weld and plate metals are apparently unaffected.

Figure 14 represents hardness survey of joint welded with low alloy Lincoln Shield Arc No. 85 electrode. Maximum hardness of heat-affected zone of plate was approximately 470 Vickers-Brinell at root, 310 at center, and 440 near the crown of weld as compared with plate metal hardness of about 310 and weld metal hardness ranging from 190 to 240. The maximum hardness is considered to be excessive and might be expected to have an adverse effect on resistance to ballistic shock.

Figure 15 represents hardness survey of joint similar to that of Fig. 14, except that it was subjected to a post heat treatment at 1000° F. for 3 hours with an air cool. The maximum hardness of the heat-affected zone of plate metal was reduced, to approximately 350 Vickers-Brinell, by this treatment. Weld metal and plate metal hardness ranges are apparently unaffected by this heat treatment.

Figure 16 represents hardness survey of joint welded with medium alloy Arcos Manganend electrode. Maximum hardness in heat-affected plate is approximately 450 Vickers-Brinell near the root, 375 at the center, and 510 near the crown as compared with plate metal hardness of 340 and weld metal hardness ranging from 250 - 430. The high weld metal hardness near the relatively narrow root is explained by greater carbon pick-up from the plate. There is a very pronounced hardness gradient in the plate metal (about 200 Vickers-Brinell) between the weld quenched zone immediately adjacent to the weld deposit and the weld annealed zone at a slightly greater distance from the weld. The excessive maximum hardness and the sharp hardness gradient in the plate metal would be expected to result in a ballistically inferior joint under shock test. On the other hand, the higher alloy content of the weld metal might result in greater resistance to penetration of the projectile or tearing due to the shock of impact.

#### Microexamination

Figures 18 through 23 show typical microstructures of armor plate and welded joints of each of the five E plates. Photomicrographs were taken on the same specimens used for hardness surveys and macroexamination. Locations of the photomicrographs are indicated in Fig. 17.

Figure 18 shows structure of both the "as welded" armor plate and the armor plate after a post heat treatment of 1000° F. for 3 hours with air cool, at 100 and 1000 magnifications in regions unaffected by welding heat.

Structures are acicular tempered martensite, typical of quenched and drawn armor plate of the type composition used. There is very slight, if any, evidence of additional tempering in the post heat treated structures. The brilliant white rectangular areas visible in the lower right hand figure are zirconium nitride, nonmetallic inclusions, occasionally seen in Great Lakes' armor compositions.

Figures 19 and 20 include views at 100 magnification of weld metal near the crown, near the root of weld and at junction of weld and plate metal for the joints made with plain carbon Murex-Fillix electrode. In all weld metal pictures, dark areas are precipitated, generally spheroidized, carbides in a white ferritic background. The amount of carbide in the weld metal depends upon the amount of carbon picked up from the plate by the weld metal, a function of the volume of weld deposit, and the welding technique. The form and distribution of the carbide depends upon the alloy content and the cooling rate of the weld deposit, carbides being finer and more uniformly dispersed with more alloy and/or faster cooling rates. A comparison of Figs. 19 and 20 indicates that heat treating at 1000° F. for 3 hours with an air cool did not significantly alter the weld metal structure.

Figure 21, representing microstructures of the low alloy Lincoln Shield Arc No. 85 electrode joint, includes an additional view of weld metal at center of weld deposit, and a view of the hardened zone of plate metal immediately adjacent to the crown of the weld. This latter area is seen to be martensitic, a structure of high hardness and strength, but low ductility and high stress, which is often responsible for the initial failure under ballistic shock.

Figure 22 represents a joint, similar to the above, which has been subjected to a post heat treatment at 1000° F. for 3 hours with an air cool. In this weld the martensitic structure adjacent to the plate has been tempered by the heat treatment, eliminating the objectionable hard structure. Structure of weld metal itself has not been significantly altered by the heat treatment.

Figure 23 represents microstructures of a medium alloy Arco Mangan-end electrode joint. The weld metal pictures indicate a much higher carbon pick-up from the plate. There is again a hardened, martensitic area in plate metal adjacent to crown of weld which might have adverse effect on resistance of joint to ballistic shock.

#### GENERAL CONSIDERATIONS

The plates welded with plain carbon, Fillix, electrode are shown by ballistic tests to be inferior with a tendency to fail through the relatively soft weld metal deposits. Heat treating for 3 hours at 1000° F. and air cooling does not change the structure nor improve the physical properties of the weld metal and consequently does not improve to any appreciable extent its resistance to ballistic shock.

The plates welded with low alloy (.40% Mn, .38% Mo) Shield Arc No. 85 electrode have a weld metal with slightly improved hardness and strength. The "as welded" plate has, adjacent to the weld deposit, a brittle heat-affected zone which was a cause of fusion zone cracking during ballistic test. Stress relieving tempers the hardened zone and improves the behavior of this joint under ballistic test.

The plate welded with ~~Arcos Manganend~~ electrode (2.17% Mn, .85% Si, .13% Cr, and .30% Mo) had a weld metal deposit more nearly approaching the unwelded plate in hardness and physical properties. In spite of excessive hardness of weld-affected plate adjacent to root and crown beads of weld deposit, the plate stood up very well under ballistic test, which unfortunately, because of placing and velocity of shots, was somewhat less severe than for some of the other plates.

It is indicated that a weld deposit of approximately the same alloy composition as the armor plate may result in a satisfactory type of ferritic weld. Through use of proper welding technique, with attention to suitable preheat for laying of root beads, maintenance of reasonably high interpass temperature and suitable placing of annealing beads, the hardening of weld-affected plate metal, with attendant tendency toward formation of hard cracks, may be reduced. Where maximum hardness of weld-affected plate is excessive, stress relieving or other post heat treatment for the purpose of tempering this structure must be considered.

642/113

TABLE I

BALLISTIC SHOCK TEST DATA

(Projectile - 37 mm. M51 T.P. - 100 yards - Normal Impact)

<u>Plate</u>	<u>Hit</u>	<u>Str. Vel.</u>	<u>Remarks</u>
HF-1	1	1999 f/s	Hit left leg about 3" above crossbar. Knocked out triangular piece of weld and plate. Weld cracked.
	2	1798 f/s	Hit left leg about 6" below crossbar. Entire left leg weld broke. (See Figs. 1 and 2.) <u>Plate in two pieces.</u>
HF-3	1	1801 f/s	Hit 1" left of left leg and 2" above crossbar. Slight bulge on back.
	2	1800 f/s	Hit right leg about 5" below crossbar. Complete penetration with crack in weld. (See Figs. 3 and 4.)
H85-1	1	1800 f/s	Hit 1-1/2" left of left leg opposite crossbar. Slight bulge.
	2	1795 f/s	Hit right leg about 4" below crossbar. Complete penetration with crack in weld.
	3	1995 f/s	Hit 2" left of leg weld about 3-1/2" below crossbar. Slight bulge.
	4	1992 f/s	Hit right leg about 2" above crossbar. Knocked out triangular piece of weld and plate. Weld cracked. (See Figs. 5 and 6.)
H85-2	1	1805 f/s	Hit 2" left of left leg opposite crossbar. Slight bulge.
	2	1801 f/s	Hit 2" left of right leg about 7" below crossbar. Slight bulge.
	3	1798 f/s	Hit on crossbar 2" left of right leg. Complete penetration. Short cracks in weld and plate.
	4	2000 f/s	Hit edge of left leg about 1-1/2" from edge of plate. Crack in fusion zone of weld. (See Figs. 7 and 8.)
H4-1	1	1796 f/s	Hit at junction of crossbar and left leg. Slight bulge. Few transverse cracks in weld.
	2	1801 f/s	Hit 3" left of right leg and 5" below crossbar. Slight bulge.
	3	1800 f/s	Hit on right leg about 1" above crossbar. Slight bulge. Crack in weld and plate on back.
	4	1802 f/s	Hit 1" right of left leg and 5" below crossbar. Transverse crack in weld. (See Figs. 9 and 10.)



WATERTOWN ARSENAL

FIGURE 1 - FRONT VIEW OF 18 X 18 X 1 INCH M PLATE ARC WELDED WITH <sup>"B"</sup> ELECTRODE, AFTER BALLISTIC TESTING. DECEMBER 4 1942 WTN.710-1967



WATERTOWN ARSENAL

"B"

FIGURE 2 - REAR VIEW OF 18 X 18 X 1 INCH M PLATE ARC WELDED WITH ~~ROPER~~ ELECTRODE, AFTER BALLISTIC TESTING. DECEMBER 4 1942 WTN.710-1968

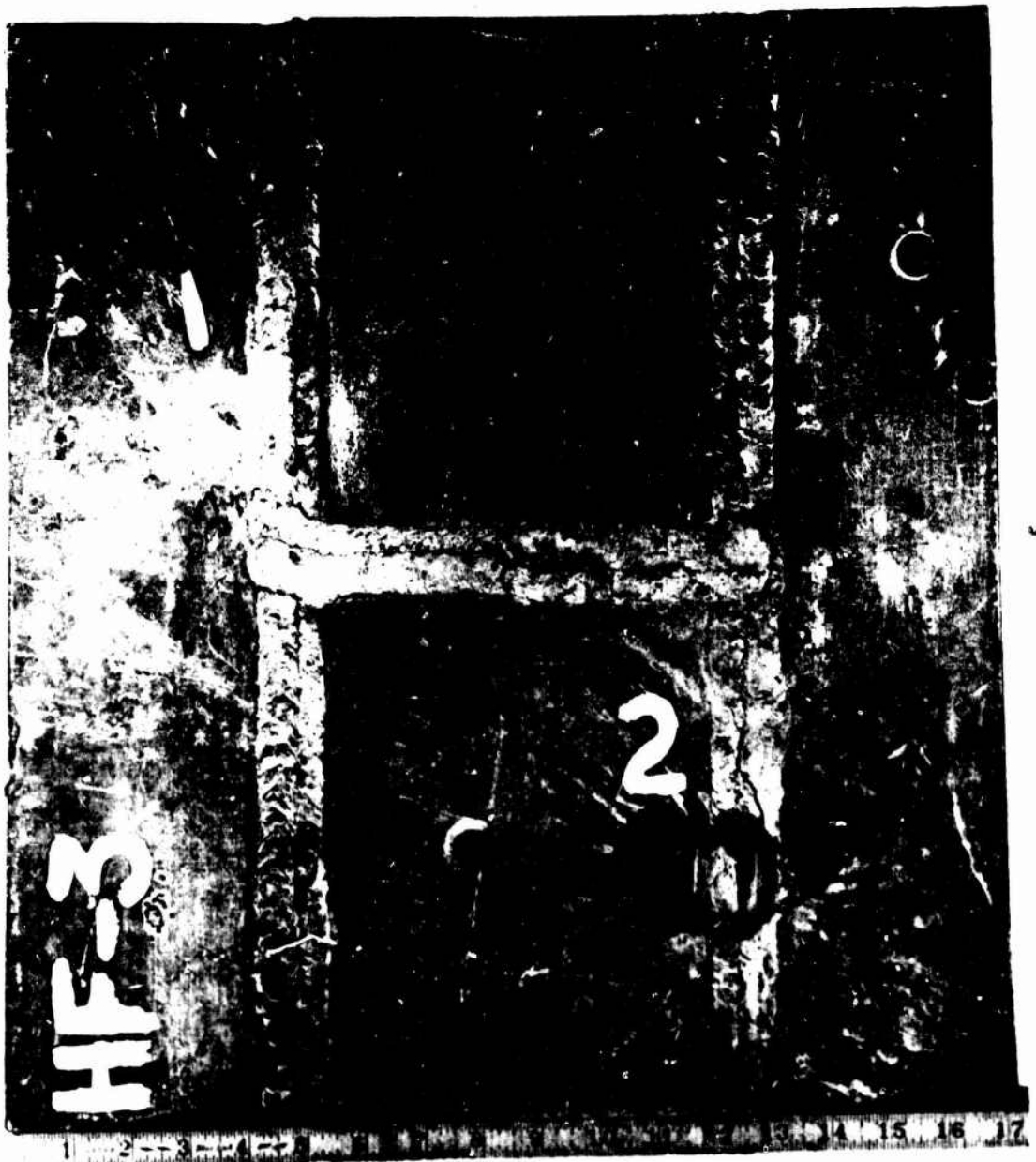

WATERTOWN ARSENAL

"B"

FIGURE 3 - FRONT VIEW OF 18 X 18 X 1 INCH M PLATE ARC WELDED WITH ~~Electrode~~  
 ELECTRODE, STRESS RELIEVED AT 1000°F FOR 3 HOURS (AIR COOL) AFTER BALLIS-  
 TIC TESTING. DECEMBER 4 1942 WTN.710-1969



WATERTOWN ARSENAL

"B"

FIGURE 4 - REAR VIEW OF 18 X 16 X 1/8 INCH PLATE ARC WELDED WITH ~~ROCKWELL~~  
ELECTRODE, STRESS RELIEVED AT 1000°F FOR 3 HOURS (AIR COOL) AFTER BALL -  
ISTIC TESTING. DECEMBER 4 1942 WTN.710-1970



WATERTOWN ARSENAL

"C"

FIGURE 5 - FRONT VIEW OF 16 X 16 X 1 INCH M PLATE ARC WELDED WITH ~~STANDARD~~  
~~STANDARD~~ ELECTRODE, AFTER BALLISTIC TESTING, DEC 4 1942 WTN.710 -1971



WATERTOWN ARSENAL

"C"

FIGURE 6 - REAR VIEW OF 16 X 16 X 1/2 INCH M PLATE ARC WELDED WITH ~~XXXXXXXXXX~~ ELECTRODE, AFTER BALLISTIC TESTING, DEC 4 '42 WTN.710-1972



WATERTOWN ARSENAL

"C"

FIGURE 7 - FRONT VIEW OF 18 X 18 X 1 INCH PLATE ARC WELDED WITH ELECTRODE, STRESS RELIEVED AT 1000°F FOR 3 HOURS (AIR COOL) AFTER BALLISTIC TESTING. DECEMBER 4 1942 WTN.710-1973

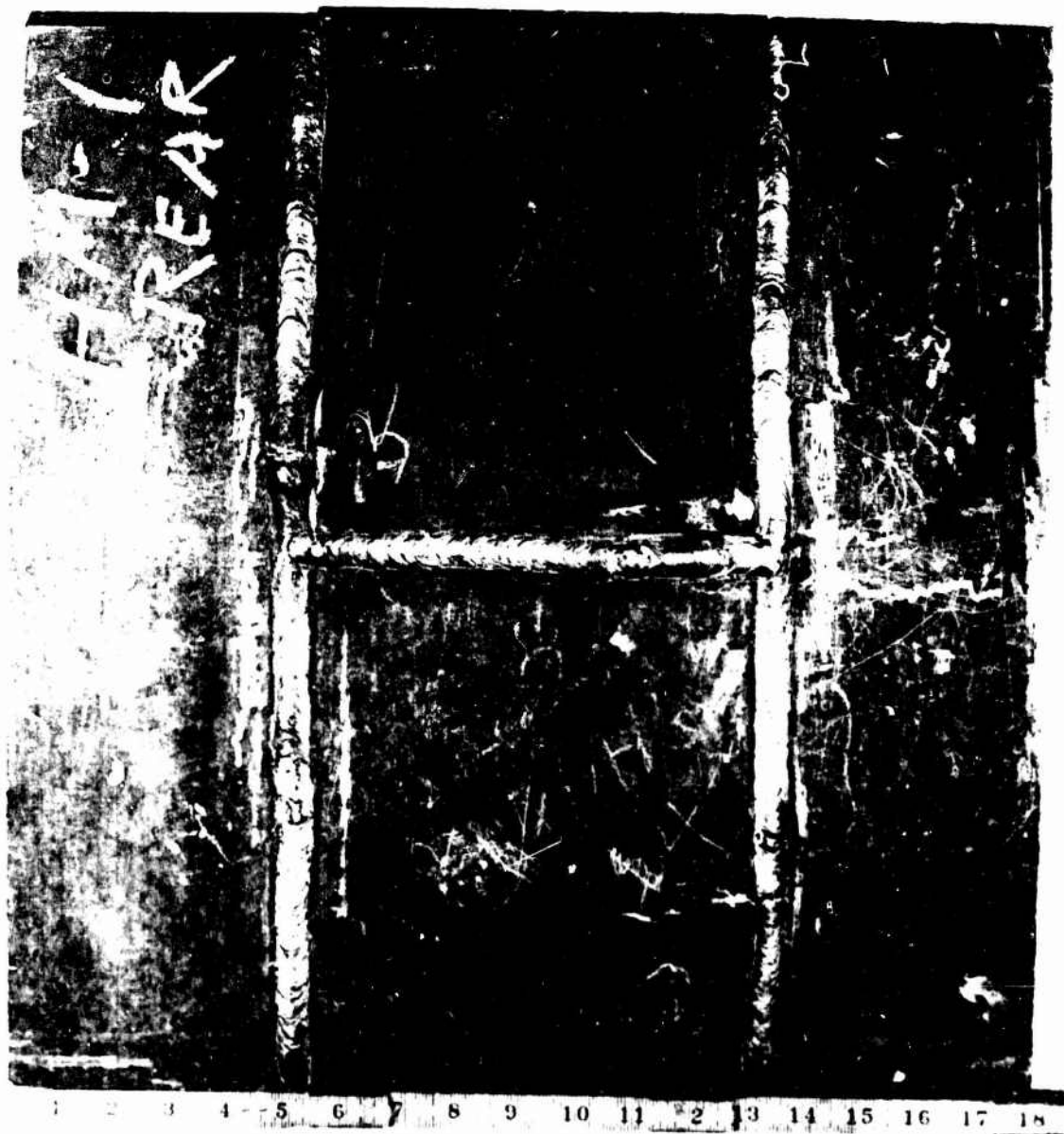

WATERTOWN ARSENAL

"A"

FIGURE 10 - REAR VIEW OF 18 X 16 X 1 INCH M PLATE ARC WELDED WITH ~~ARC~~ ELECTRODE, AFTER BALLISTIC TESTING, DEC 4 '42 WTN. 710-1976



SINGLE V JOINT WELDED WITH PLAIN CARBON ~~MUREX~~ ELECTRODE. AS WELDED ✓

"B"



SINGLE V JOINT WELDED WITH PLAIN CARBON ~~MUREX~~ ELECTRODE. STRESS RELIEVED AT 1000°F FOR 3 HRS. AND AIR COOLED

"B"



SINGLE V JOINT WELDED WITH LOW ALLOY ~~LOW ALLOY~~ ELECTRODE. AS WELDED

"C"



SINGLE V JOINT WELDED WITH LOW ALLOY ~~LOW ALLOY~~ ELECTRODE. STRESS RELIEVED AT 1000°F FOR 3 HRS. AND AIR COOLED

"C"



SINGLE V JOINT WELDED WITH ~~MUREX~~ ELECTRODE. AS WELDED

"A"



ORDNANCE DEPT U.S.A.  
WATERLOO ARSENAL

CROSS SECTIONS FROM CROSS BAR OF 16" X 16" X 1" WELDED "M" PLATES  
AS PREPARED FOR MACROEXAMINATION - MGF IX, NITAL - PICRAL ETCH  
JANUARY 4 1943 WTN.121-513

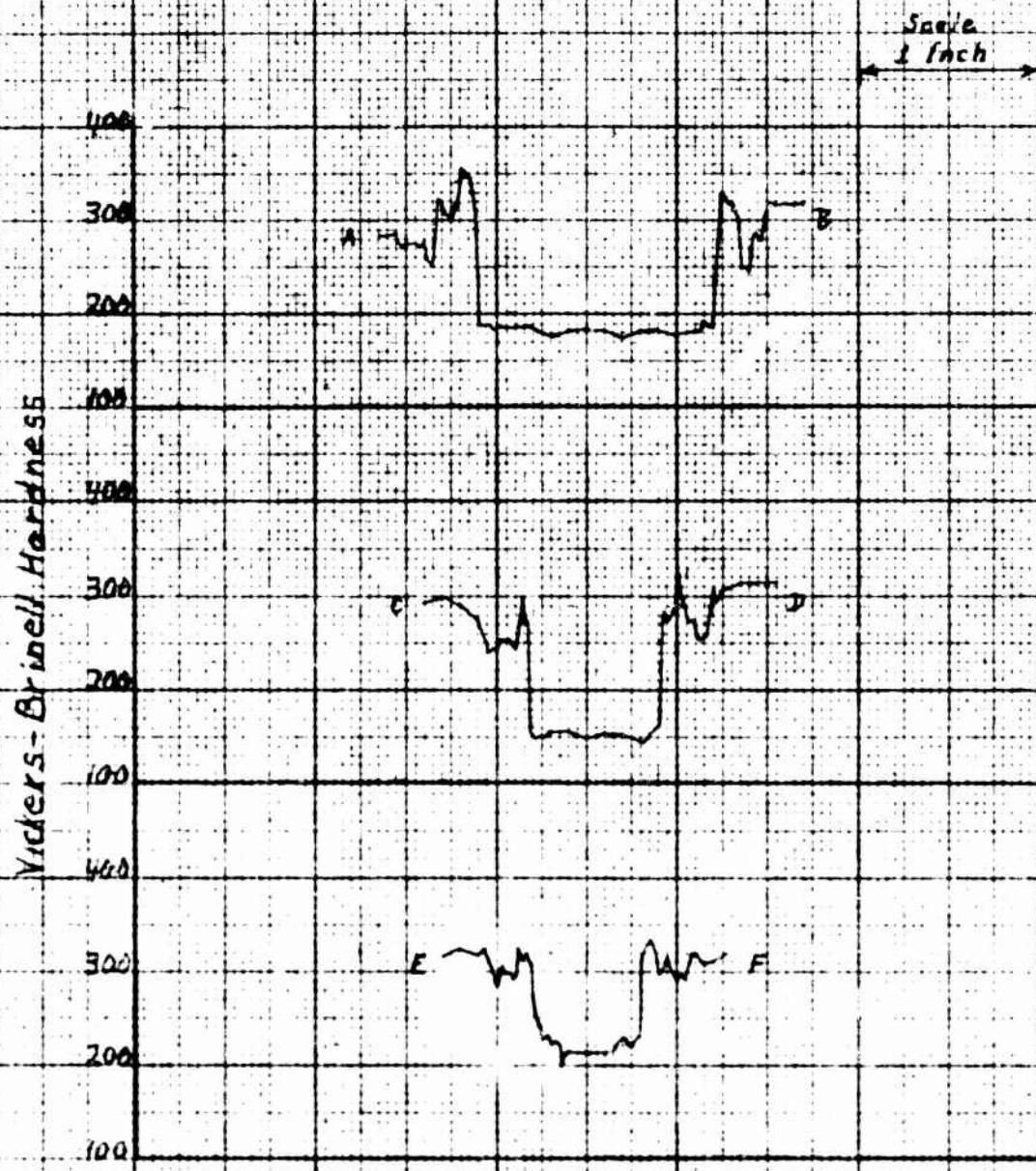
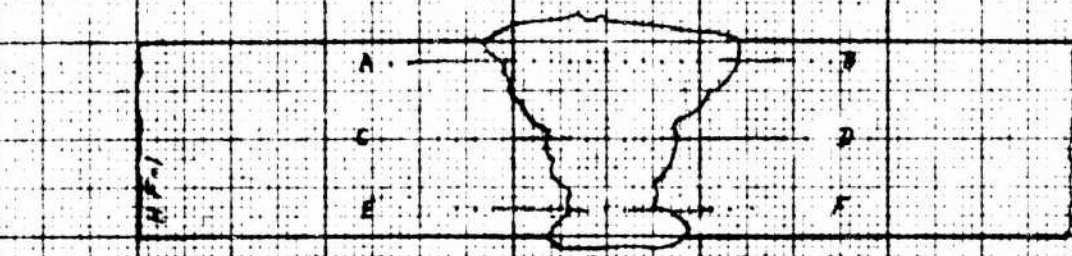
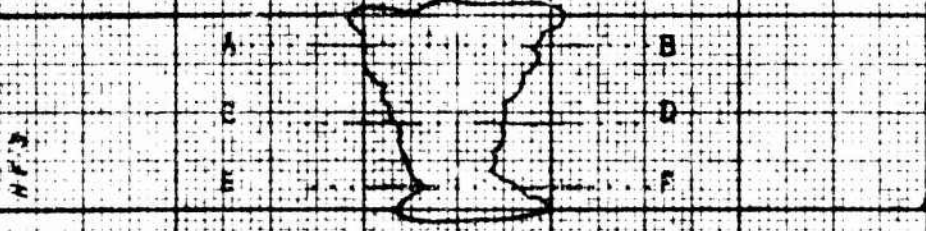

FIGURE 13. SINGLE V JOINT WELDED WITH PLAIN CARBON MIMEX-FILDED ELECTRODE. AS WELDED.

642/113



Scale  
1 Inch

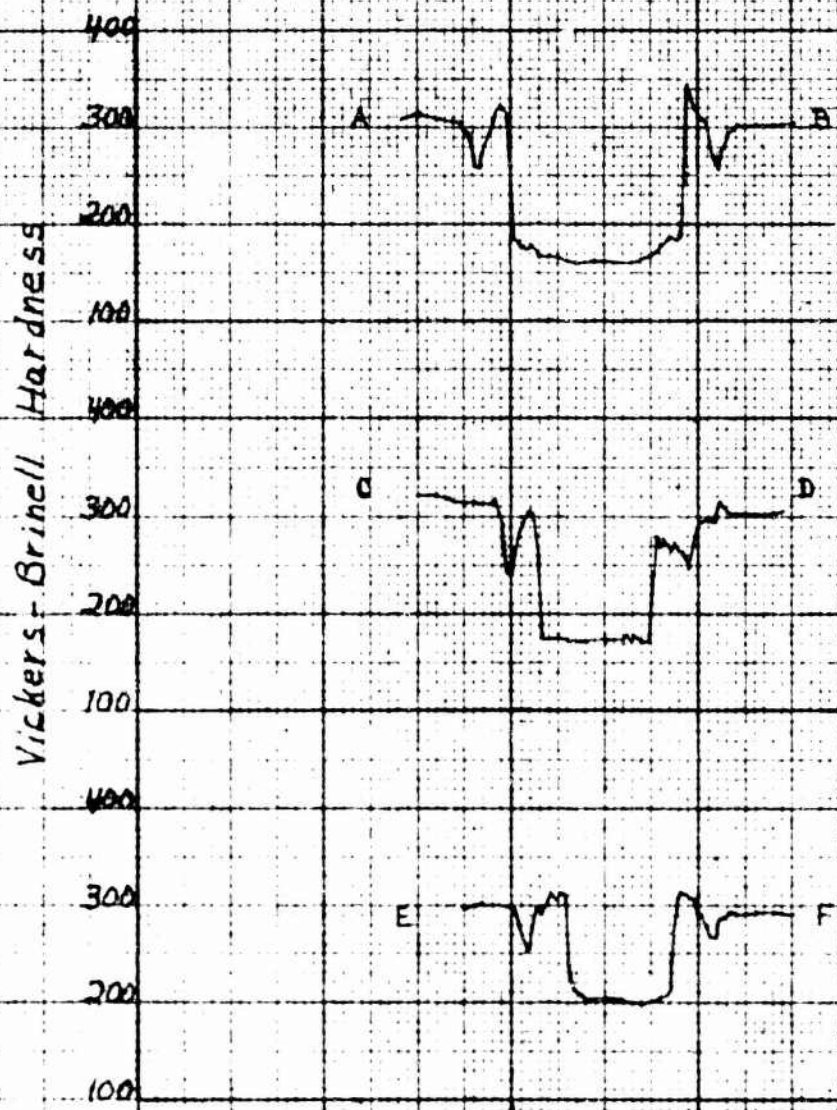

FIGURE 13. SINGLE V JOINT WELDED WITH PLAIN CARBON MUREX FILLET ELECTRODE. STRESS RELIEVED AT 1000°F FOR 3 HRS. AND AIR COOLED.

642/113

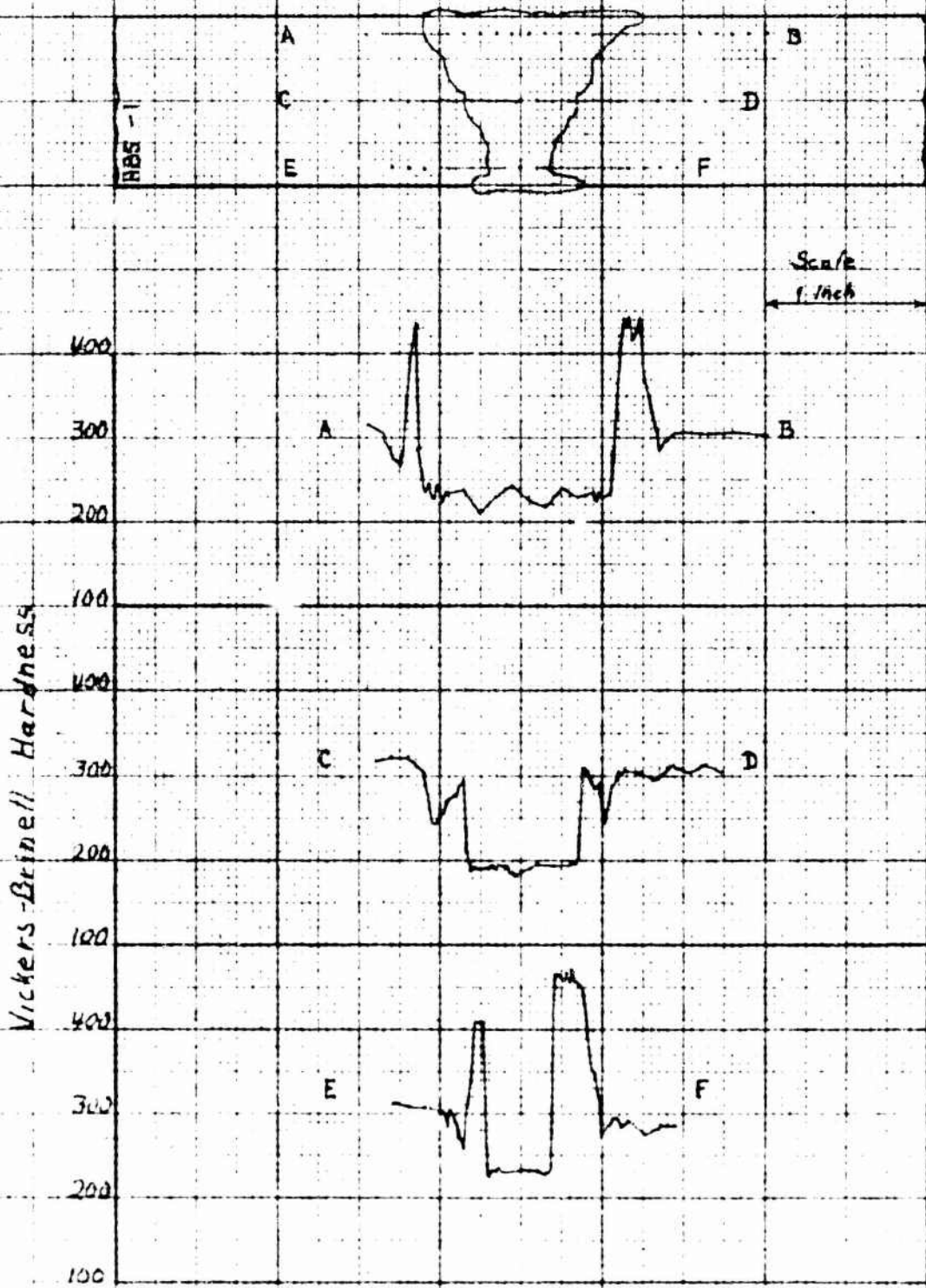

FIGURE 14. SINGLE V JOINT WELDED WITH LOW ALLOY  
~~LITCOLE SHIELD AND 405~~ ELECTRODE. AS  
 WELDED

642/113

642/113

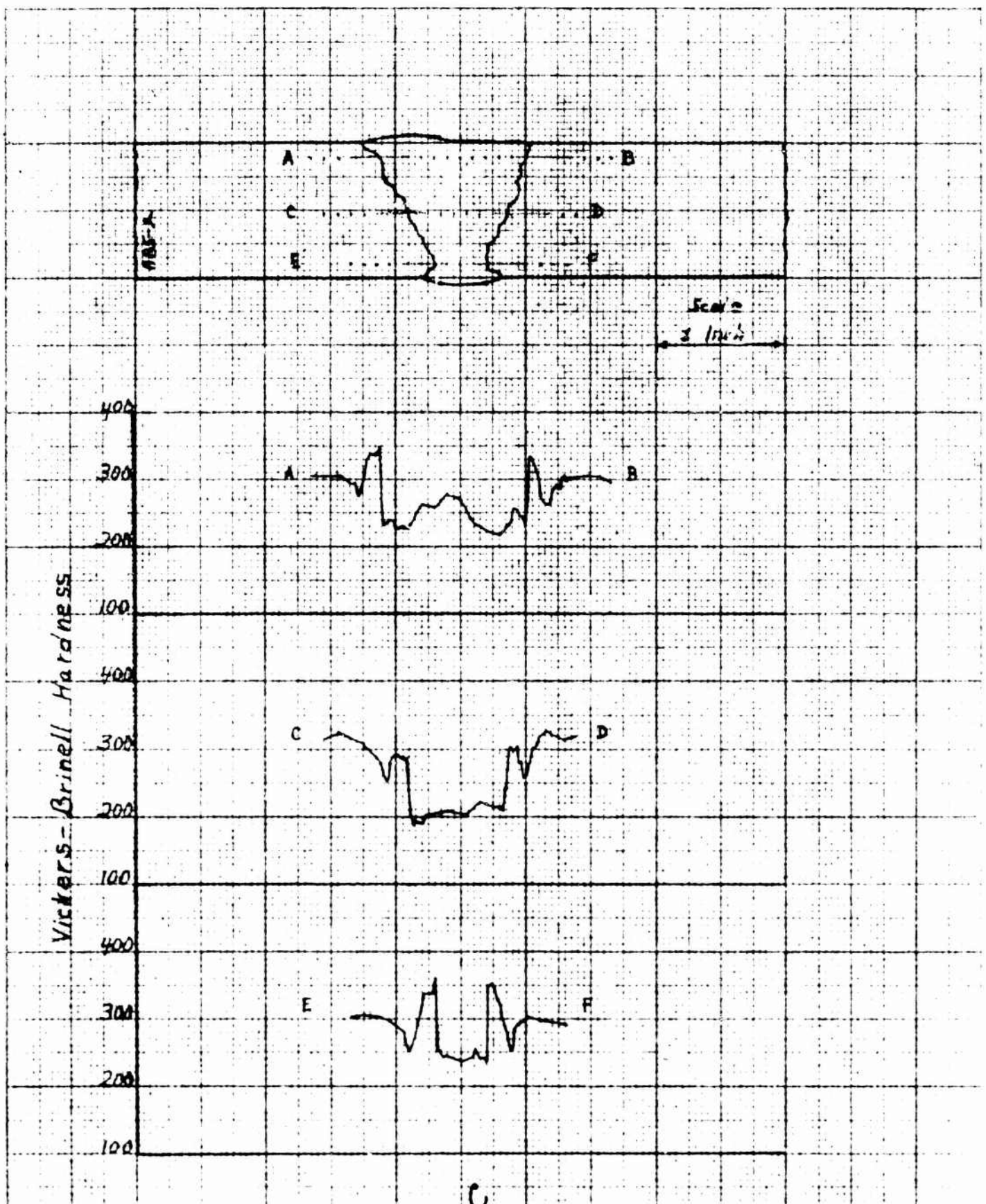

FIGURE 15. SINGLE V JOINT WELDED WITH LOW ALLOY  
LINCOLN SHIELD METAL ARC ELECT. GDE.  
STRESS RELIEVED AT 1000°F FOR 3 HRS.  
AND AIR COOLED.

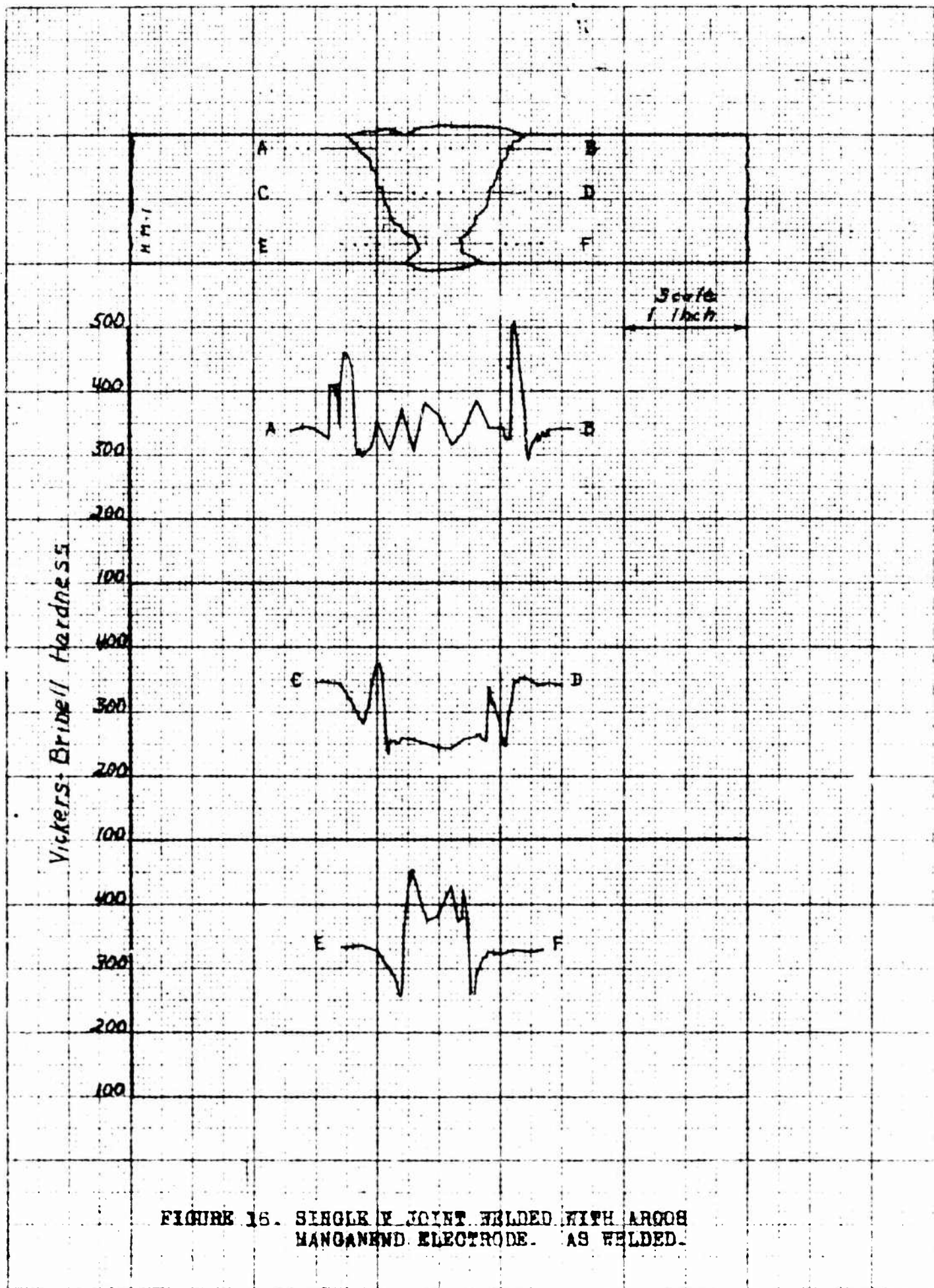
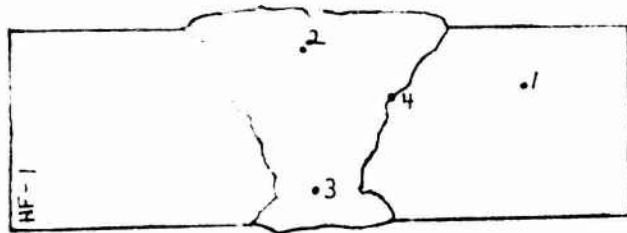
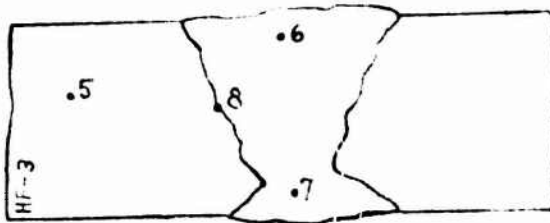

FIGURE 16. SINGLE V JOINT WELDED WITH ARC-ON MANGANESE ELECTRODE. AS WELDED.



SINGLE V JOINT WELDED WITH  
PLAIN CARBON MUREX-FILLEX  
ELECTRODE. AS WELDED



SINGLE V JOINT WELDED WITH  
PLAIN CARBON MUREX-FILLEX  
ELECTRODE. STRESS RELIEVED  
AT 1000°F FOR 3 HRS. AND  
AIR COOLED

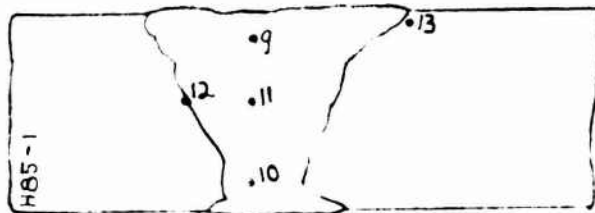

SINGLE V JOINT WELDED WITH  
LOW ALLOY LINCOLN SHIELD ARC  
E85 ELECTRODE. AS WELDED

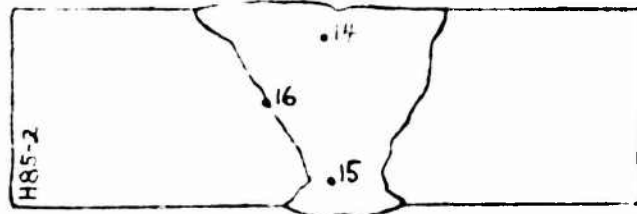

SINGLE V JOINT WELDED WITH  
LOW ALLOY LINCOLN SHIELD ARC  
E85 ELECTRODE. STRESS RELIEVED  
AT 1000°F FOR 3 HRS. AND  
AIR COOLED

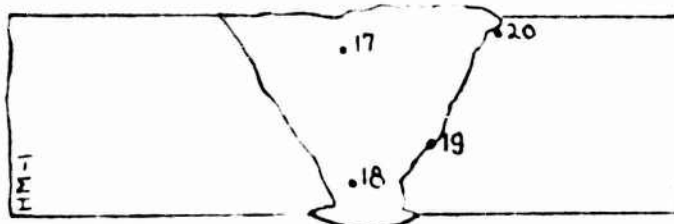

SINGLE V JOINT WELDED WITH  
ARCOS MANGANEND ELECTRODE.  
AS WELDED

FIGURE 17. LOCATIONS OF PHOTOMICROGRAPHS

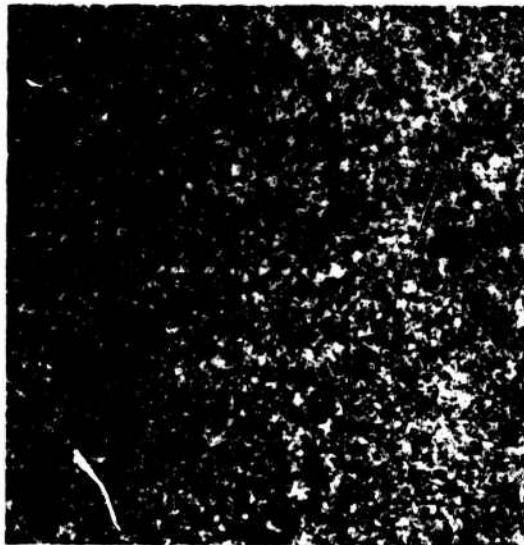

X100



X1000

1/8 NITAL

1/8 NITAL

PLATE NOT STRESS RELIEVED  
(LOCATION 1)

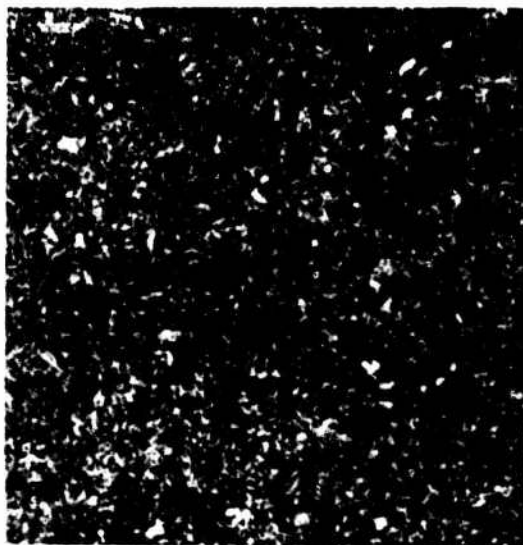

X100

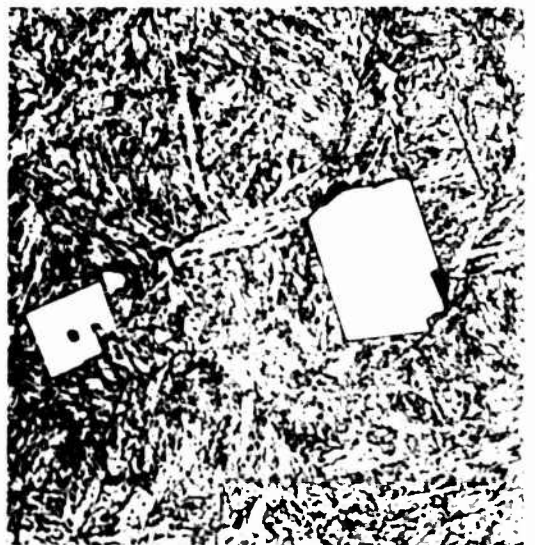

X1000

1/8 NITAL

1/8 NITAL

MTN.639-4901

PLATE STRESS RELIEVED AT 1000°F FOR 3 HOURS AND AIR COOLED (LOCATION 5)

FIGURE 1B. MICROSTRUCTURE OF UNAFFECTED PLATE METAL

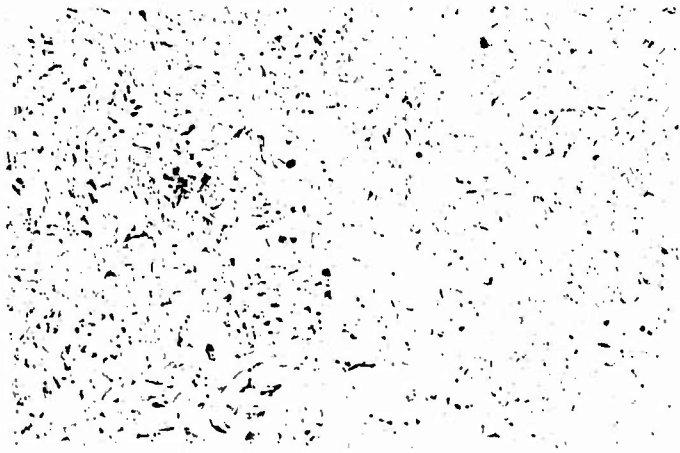

X100 1% NITAL  
 MICROSTRUCTURE OF WELD METAL NEAR CROWN (LOCATION 2)

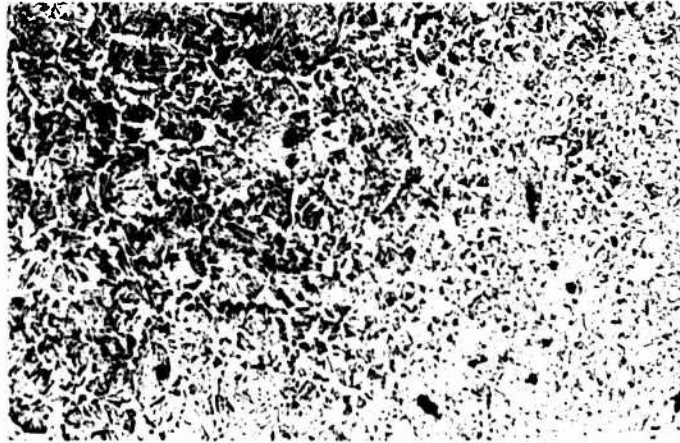

X100 1% NITAL  
 MICROSTRUCTURE OF WELD METAL NEAR ROOT (LOCATION 3)

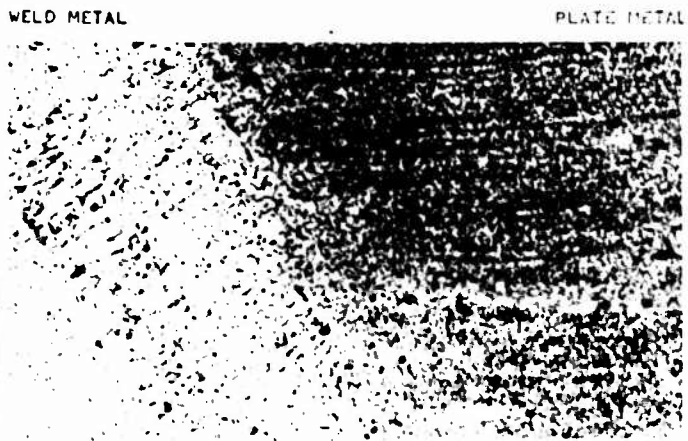

X100 1% NITAL  
 MICROSTRUCTURE AT BOUNDARY BETWEEN PLATE AND WELD METAL  
 (LOCATION 4)

FIGURE 19. SINGLE V JOINT WELDED WITH PLAIN CARBON ~~WELDING~~ ELECTRODE AND WELDED.

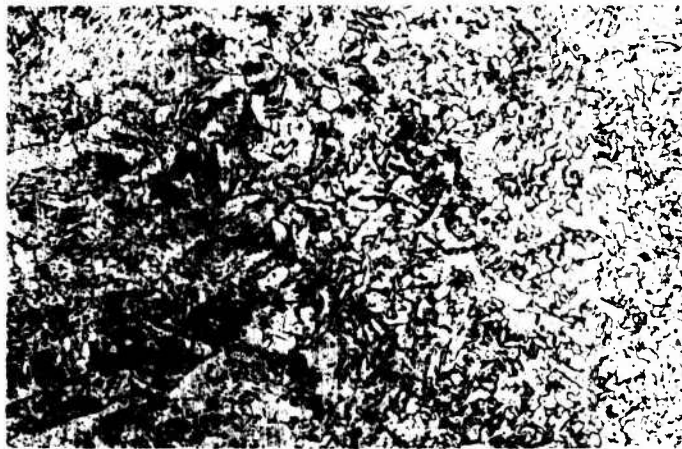

X100 1% NITAL  
 MICROSTRUCTURE OF WELD METAL NEAR CROWN (LOCATION 6)

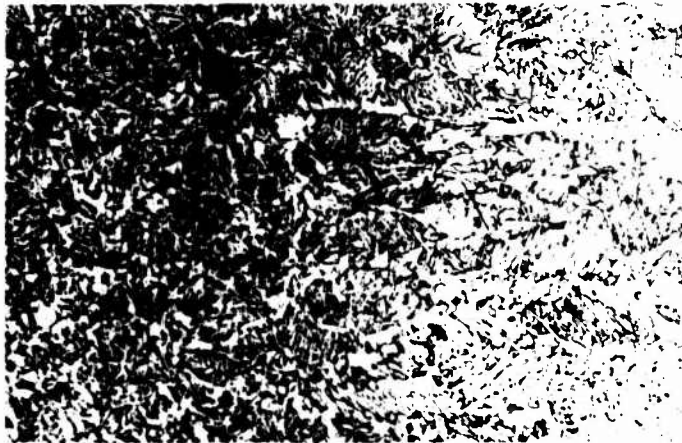

X100 1% NITAL  
 MICROSTRUCTURE OF WELD METAL NEAR ROOT. (LOCATION 7)

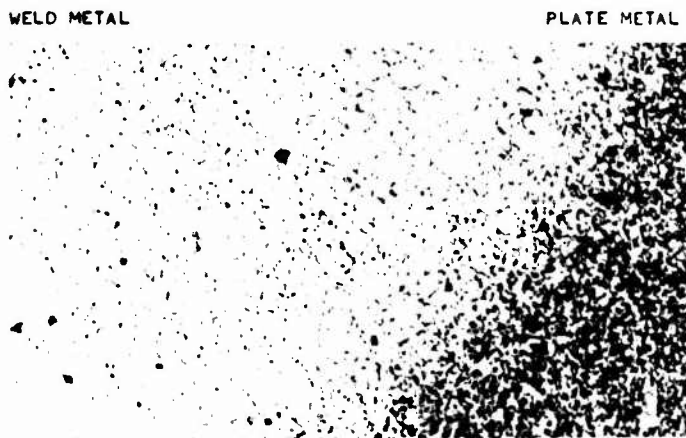

X100 1% NITAL  
 MICROSTRUCTURE AT BOUNDARY BETWEEN PLATE AND WELD METAL  
 (LOCATION 8)

WTN.630-4962

FIGURE 20. SINGLE V JOINT WELDED WITH PLAIN CARBON ~~WELDING~~ <sup>"E"</sup> ELECTRODE. 115E  
 RELIEVED AT 1000°F FOR 3 HRS. AND AIR COOLED.

X100

1% NITAL



MICROSTRUCTURE OF WELD METAL NEAR CROWN (LOCATION 9)

X100

1% NITAL



MICROSTRUCTURE OF WELD METAL NEAR ROOT (LOCATION 10)

X100

1% NITAL



MICROSTRUCTURE OF WELD METAL NEAR CENTER OF WELD (LOCATION 11)

X100

1% NITAL

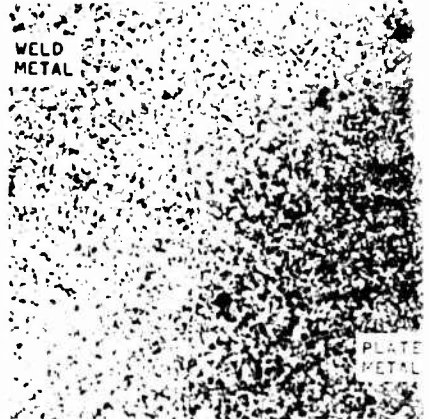

MICROSTRUCTURE AT BOUNDARY BETWEEN PLATE AND WELD METAL (LOCATION 12)

X100

1% NITAL

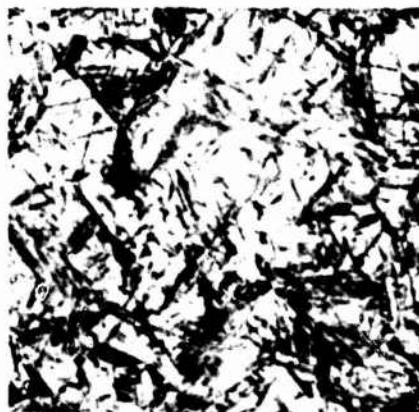

MICROSTRUCTURE OF HEAT AFFECTED PLATE IMMEDIATELY ADJACENT TO WELD NEAR EDGE (LOCATION 13)

X1000

1% NITAL

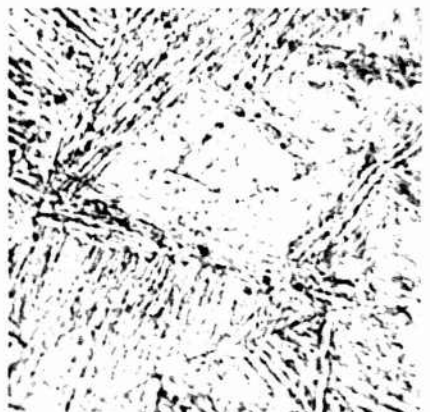

MTN.C39-4981



X100 1% NITAL  
 MICROSTRUCTURE OF WELD METAL NEAR ROOT (LOCATION 14)



X100 1% NITAL  
 MICROSTRUCTURE OF WELD METAL NEAR CROWN (LOCATION 15)



X100 1% NITAL  
 MICROSTRUCTURE AT BOUNDARY BETWEEN PLATE AND WELD METAL (LOCATION 16)

MTN-630-4904

FIGURE 22. SINGLE V JOINT WELDED WITH LOW ALLOY ELECTRODE. STRESS RELIEVED AT 1000°F FOR 3 HOURS AND AIR COOLED.





WATERTOWN ARSENAL

"C"

FIGURE 5 - REAR VIEW OF 18 X 18 X 1 INCH PLATE ARC WELDED WITH ~~XXXXXXXXXX~~ ELECTRODE, STRESS RECEIVED AT 1000°F FOR 3 HOURS (AIR COOL) AFTER BALLISTIC TESTING. DECEMBER 4 1942 WTN.710-1974

APPENDIX A

WELDING DATA

642/113

APPENDIX A

WELDING DATA

<u>Weld</u>	<u>Layer</u>	<u>Electrode Dia.</u>	<u>Amp.</u>	<u>Volts</u>	<u>Remarks</u>
<u>PLATE HF-1, Electrode Fillex (Straight Polarity)</u>					
Legs	1st	5/32"	165	27	Single deposit
	2nd	5/32	165	27	" "
	3rd	3/16	230	26	" "
	4th	3/16	230	26	" "
	5th	3/16	230	26	" "
	6th	3/16	230	26	" "
	7th	3/16	230	26	Two beads, side by side
	8th	3/16	230	26	" " " " "
	9th	3/16	230	26	" " " " "
Crossbar	1st	5/32"	170	26	Single deposit
	2nd	5/32	170	26	" "
	3rd	3/16	230	27	" "
	4th	3/16	230	27	" "
	5th	3/16	230	27	" "
	6th	3/16	230	27	Two beads, side by side
	7th	3/16	230	27	" " " " "
	8th	3/16	230	27	" " " " "
	9th	3/16	230	27	" " " " "

Back strip (Figure B) chipped off and light cut taken out of root to sound metal. Two beads deposited with 3/16" Fillex at 225 Amps. 26 Volts to form the Seal Bead.

PLATE HF-2, Electrode Fillex (Straight Polarity)

Legs	1st	5/32"	165	25	Single deposit
	2nd	5/32	165	25	" "
	3rd	3/16	220	28	" "
	4th	3/16	220	28	" "
	5th	3/16	220	28	" "
	6th	3/16	220	28	Two beads, side by side
	7th	3/16	220	28	" " " " "
	8th	3/16	220	28	" " " " "
	9th	3/16	220	28	" " " " "
Crossbar	1st	5/32"	160	25	Single deposit
	2nd	5/32	160	25	" "
	3rd	3/16	220	28	" "
	4th	3/16	220	28	" "
	5th	3/16	220	28	" "
	6th	3/16	225	27	" "
	7th	3/16	225	27	Two beads, side by side
	8th	3/16	225	27	" " " " "
	9th	3/16	225	27	" " " " "

Back strip (Figure B) chipped off. Weld in crossbar found to be cracked too deep to repair by seal bead. Plate laid aside.

642/113

<u>Weld</u>	<u>Layer</u>	<u>Electrode Dia.</u>	<u>Amp.</u>	<u>Volts</u>	<u>Remarks</u>
<u>PLATE H2-3, Electrode <del>Filler</del> (Straight Polarity)</u>					
Legs	1st	1/8"	120	22	Single deposit
	2nd	5/32	175	24	" "
	3rd	3/16	230	27	" "
	4th	3/16	230	27	" "
	5th	3/16	230	27	" "
	6th	3/16	230	27	Two beads, side by side
	7th	3/16	230	27	" " " " "
	8th	3/16	230	27	" " " " "
	9th	3/16	230	27	" " " " "
Crossbar	1st	1/8"	130	18	Single deposit
	2nd	5/32	170	29	" "
	3rd	3/16	220	29	" "
	4th	3/16	220	29	" "
	5th	3/16	220	29	" "
	6th	3/16	220	29	Two beads, side by side
	7th	3/16	220	29	" " " " "
	8th	3/16	225	28	" " " " "
	9th	3/16	225	28	" " " " "

Backing strip (Figure B) chipped off and light cut taken out of root to sound metal. Two beads deposited with 3/16" ~~Filler~~ at 225 Amps. 25 Volts to form the Seal Bead.

PLATE H25-1, Electrode ~~Shield-Arc #85~~ (Reversed Polarity)

Legs	1st	5/32"	145	26	Single deposit
	2nd	5/32	145	26	" "
	3rd	5/32	145	26	Two beads, side by side
	4th	5/32	145	26	" " " " "
	5th	5/32	145	26	" " " " "
	6th	5/32	145	26	Three " " " "
	7th	5/32	145	26	" " " " "
	8th	5/32	140	27	" " " " "
Crossbar	1st	5/32"	140	27	Single deposit
	2nd	5/32	140	27	" "
	3rd	5/32	140	27	" "
	4th	5/32	145	26	Two beads, side by side
	5th	5/32	145	26	" " " " "
	6th	5/32	145	26	" " " " "
	7th	5/32	140	27	Three " " " "
	8th	5/32	140	27	" " " " "

Backing strip (Figure B) chipped off and light cut taken out of root to sound metal. One bead deposited with 5/32" ~~Shield-Arc #85~~ 150 Amps. 26 Volts to form the Seal Bead.

<u>Weld</u>	<u>Layer</u>	<u>Electrode Dia.</u>	<u>Amp.</u>	<u>Volts</u>	<u>Remarks</u>
<u>PLATE HS-2, Electrode <del>Shield Arc #85</del> (Reversed Polarity)</u>					
Legs	1st	5/32"	145	26	Single deposit
	2nd	5/32	145	26	" "
	3rd	5/32	145	26	Two beads, side by side
	4th	5/32	145	26	" " " "
	5th	5/32	140	27	" " " "
	6th	5/32	140	27	Three " " " "
	7th	5/32	140	27	" " " "
	8th	5/32	135	28	" " " "
Crossbar	1st	5/32"	150	24	Single deposit
	2nd	5/32	150	24	" "
	3rd	5/32	145	25	" "
	4th	5/32	145	25	Two beads, side by side
	5th	5/32	145	25	" " " "
	6th	5/32	145	25	" " " "
	7th	5/32	135	27	Three " " " "
	8th	5/32	135	27	" " " "

Backing strip (Figure B) chipped off and light cut taken out of root to sound metal. One bead deposited with 5/32" ~~Shield Arc #85~~ 150 Amps. 26 Volts to form the Seal Bead.

<u>Weld</u>	<u>Layer</u>	<u>Electrode Dia.</u>	<u>Amp.</u>	<u>Volts</u>	<u>Remarks</u>
<u>PLATE HM-1, Electrode <del>Manganend-2M6</del> (Reversed Polarity)</u>					
Legs	1st	5/32"	190	22	Single deposit
	2nd	5/32	190	22	" "
	3rd	3/16	245	22	" "
	4th	3/16	245	22	Two beads, side by side
	5th	3/16	230	22	Three " " " "
	6th	3/16	230	22	" " " "
	7th	3/16	230	22	" " " "
	8th	5/32	190	21	Four " " " "
Crossbar	1st	5/32"	190	22	Single deposit
	2nd	5/32	190	22	" "
	3rd	5/32	190	22	" "
	4th	3/16	240	22	Two beads, side by side
	5th	3/16	240	22	" " " "
	6th	3/16	240	22	" " " "
	7th	5/32	190	21	Four " " " "
	8th	5/32	190	21	" " " "

Backing strip (Figure B) chipped off and light cut taken out of root to sound metal. One bead deposited with 5/32" ~~Manganend~~ 185 Amps. 22 Volts to form the Seal Bead.

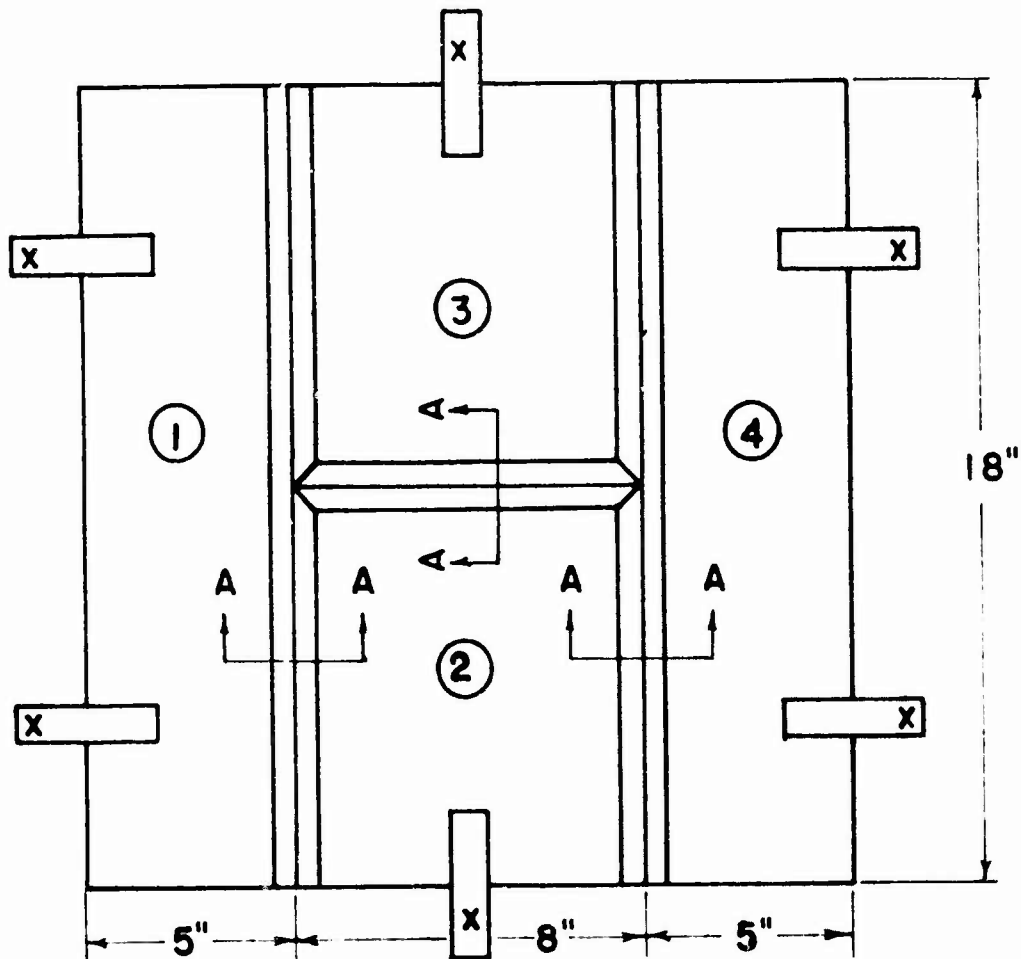

X-HOLD DOWN STRAPS.

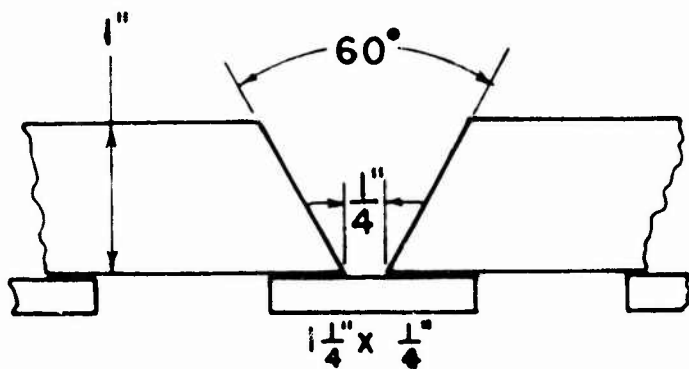

SECTION A-A

ASSEMBLY OF H-PLATES FOR WELDING

FIGURE A

642/113

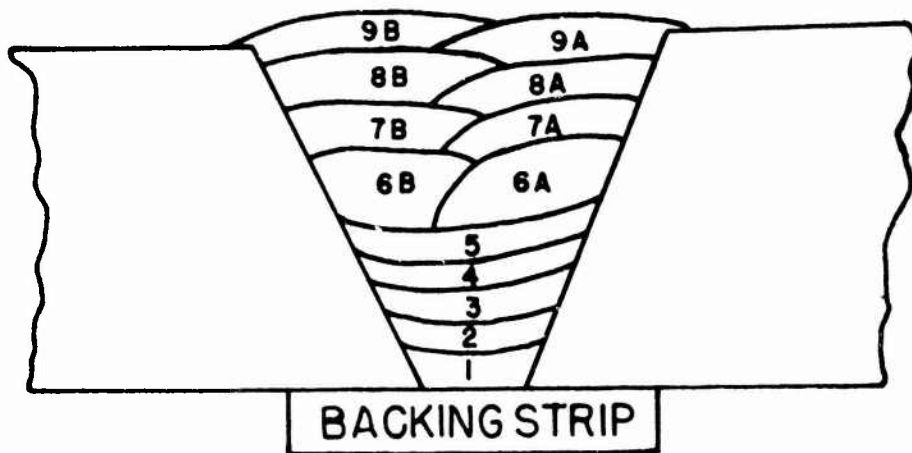

A

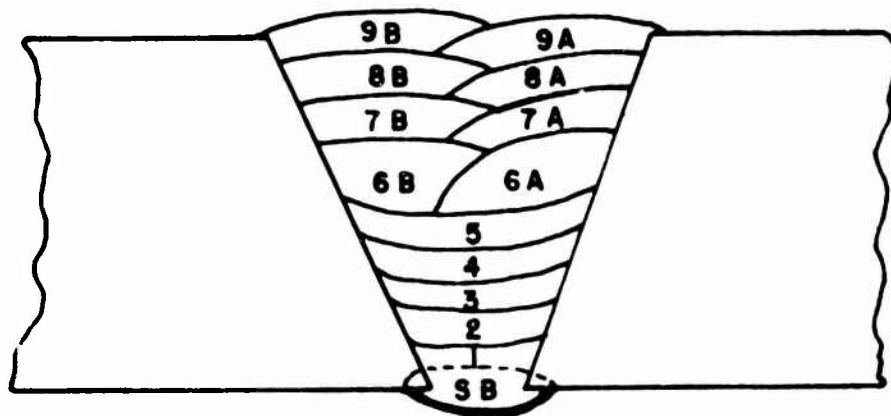

B

TYPICAL  
WELD METAL DEPOSITION

FIGURE B

642/113

RESTRICTED

TITLE: H-Plates in 1" Rolled Homogeneous Armor Welded with Ferritic Electrodes

ATI- 39463

AUTHOR(S): Zorning, H. H.

ORIGINATING AGENCY: Watertown Arsenal, Watertown, Mass.

PUBLISHED BY: (Same)

DIVISION

(None)

ORIG. AGENCY NO.

TB-W-8

PUBLISHING AGENCY NO.

(Same)

DATE	DOC. CLASS.	COUNTRY	LANGUAGE	PAGES	ILLUSTRATIONS
April '43	Restr.	U.S.	Eng.	8	tables, drwgs

ABSTRACT:

Five H plates in 1" rolled homogeneous armor welded with plain carbon, low alloy and medium alloy ferritic electrodes were tested. The following approximate composition was used: .28 C, .85 Mo, .55 St, .70 Cr, .21 Mn, .028 S, .06 Zr and .028 P. The plate was quenched and drawn to approximately 310 Brinell. The parts were flame cut after preheating to 400°F and the cut surfaces were lightly ground to remove excess scale and irregularities. All welding was carried out with the armor heated to a temperature of 125° to 175°F. The plates were tested at the 100-yd range with T.P. M51 37 mm projectiles. Results of the ballistic tests are given in tabular form. The plain carbon welds did not stand up at 1800 ft/sec. The medium alloy plate hit four times at 1800 ft/sec did not show complete penetration and did not crack.

DISTRIBUTION: Copies of this report obtainable from Air Documents Division; Attn: MCIDXD

DIVISION: Ordnance armament (22)

SECTION: Armor (5)

SUBJECT HEADINGS: Armor plate, Welded - Stresses (11530); Armor plate - Penetration (11503)

ATI SHEET NO.: R-22-5-33

Air Documents Division, Intelligence Department  
Air Materiel Command

AIR TECHNICAL INDEX  
RESTRICTED

Wright-Patterson Air Force Base  
Dayton, Ohio