

AD-A956 500



Information is estimated to average 1 hour per response, including the time for reviewing instructions, searching existing data sources, completing and reviewing the collection of information. Send comments regarding this burden estimate or any other aspect of this or reducing this burden, to Washington Headquarters Services, Directorate for Information Operations and Reports, 1215 Jefferson 4302, and to the Office of Management and Budget, Paperwork Reduction Project (0704-0188), Washington, DC 20503.

2. REPORT DATE 06/00/77		3. REPORT TYPE AND DATES COVERED	
4. TITLE AND SUBTITLE INVESTIGATIONS OF THE ENVIRONMENTAL FATE AND PHYTOTOXICITY OF DIMP AND DCPD		5. FUNDING NUMBERS DAMD 17 75 C 5069	
6. AUTHOR(S) O'DONOVAN, P., WOODWARD, J.		8. PERFORMING ORGANIZATION REPORT NUMBER 81335R08	
7. PERFORMING ORGANIZATION NAME(S) AND ADDRESS(ES) ROCKET ORDNANCE AND MANUFACTURING CO. DOWNEY, CA		10. SPONSORING / MONITORING AGENCY REPORT NUMBER	
9. SPONSORING / MONITORING AGENCY NAME(S) AND ADDRESS(ES) ARMY MEDICAL RESEARCH AND DEVELOPMENT COMMAND WASHINGTON, DC		11. SUPPLEMENTARY NOTES	
12a. DISTRIBUTION / AVAILABILITY STATEMENT APPROVED FOR PUBLIC RELEASE; DISTRIBUTION IS UNLIMITED		12b. DISTRIBUTION CODE	
13. ABSTRACT (Maximum 200 words) THE OBJECTIVE WAS TO STUDY THREE ASPECTS OF THE PROBLEM OF CONTAMINANT CHEMICALS IN THE SOIL OF ROCKY MOUNTAIN ARSENAL, COLORADO IN PARTICULAR AND OTHER SOILS IN GENERAL: (1) THE DETERMINATION OF CONCENTRATION LEVELS OF THE CONTAMINANTS THAT WOULD PRODUCE PHYTOTOXIC SYMPTOMS IN PLANTS, (2) ESTABLISHING THE EXISTENCE AND DEGREE OF THE BIOCONCENTRATION OF THESE CHEMICALS IN THE PLANTS, AND (3) A STUDY OF THE STABILITY OR MOVEMENT OF THESE CHEMICALS IN VARIOUS TYPES OF SOILS WITH TWO METHODS OF APPLICATION. THE SPECIFIC CHEMICALS OF INTEREST IN THIS STUDY WERE DIMP AND DCPD.			
14. SUBJECT TERMS CONTAMINANTS, SOIL, CHEMICALS, PLANTS, DICYCLOPENTADIENE		15. NUMBER OF PAGES	
		16. PRICE CODE	
17. SECURITY CLASSIFICATION OF REPORT UNCLASSIFIED	18. SECURITY CLASSIFICATION OF THIS PAGE	19. SECURITY CLASSIFICATION OF ABSTRACT	20. LIMITATION OF ABSTRACT

SDTIC
ELECTE
NOV 16 1993
S E D

DISCLAIMER NOTICE

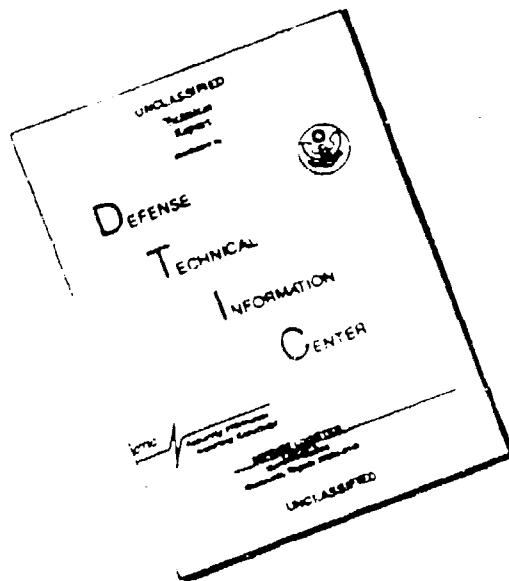

THIS DOCUMENT IS BEST QUALITY AVAILABLE. THE COPY FURNISHED TO DTIC CONTAINED A SIGNIFICANT NUMBER OF PAGES WHICH DO NOT REPRODUCE LEGIBLY.

1953-01(01)FP

FILE COPY

INVESTIGATIONS OF THE ENVIRONMENTAL FATE
AND PHYTOTOXICITY OF DIMP AND DCPD

FINAL REPORT

by

P. A. O'DONOVAN
J. E. WOODWARD

*Rocky Mountain Arsenal
Information Center
Commerce City, Colorado*

JUNE 1977

Supported by

U. S. ARMY MEDICAL RESEARCH AND DEVELOPMENT COMMAND
Washington, D. C. 20314

PROJECT OFFICER: Captain John P. Glennon

Contract No. DAMD-17-75-C-5069

Aerojet Ordnance and Manufacturing Company
Downey, California 90241

APPROVED FOR PUBLIC RELEASE;
DISTRIBUTION UNLIMITED

The findings in this report are not to be construed as an
official Department of the Army position unless so designated
by other authorized documents

Accession For	
NTIS CRA&I	<input checked="" type="checkbox"/>
DTIC TAB	<input checked="" type="checkbox"/>
Unannounced	<input type="checkbox"/>
Justification	
By	
Distribution/	
Availability Codes	
Dist	Avail and/or Special
A-1	

DTIC QUALITY INSPECTED 5

93-27138



154/198

CC 1 2 201

SUMMARY

Contract No. DAMD-17-75-C-5069 had as its objective a study of three aspects of the problem of contaminant chemicals in the soil of Rocky Mountain Arsenal (RMA), Colorado in particular and other soils in general. The three aspects of the problem studied were (1) the determination of concentration levels of the contaminants that would produce phytotoxic symptoms in plants, (2) establishing the existence and degree of the bioconcentration of these chemicals in the plants and (3) a study of the stability or movement of these chemicals in various types of soil with two methods of application.

The specific chemicals of interest in this study were DIMP (diisopropyl methyl phosphonate) and DCPD (dicyclopentadiene). These two chemicals have been identified as contaminants in RMA soil and are waste products of, in the case of DIMP, former war gas manufacturing; and in the case of DCPD, of pesticide manufacturing by a commercial user of the RMA facility.

The methods selected for studying the behavior of plants treated with the subject chemicals were hydroponic culture for the broad survey-range finding approach and soil culture for the more specific determination of effect levels. The hydroponic studies used ten species of plants: corn, beans,

radish, wheat, tomato, carrot, sugar beet, meadow fescue, rose, and juniper.

The soil studies included carrot, wheat, alfalfa, sugar beet, and bean.

The hydroponic studies were conducted in two greenhouses in perforated plastic tubs in which the plant roots were supported in loosely packed gravel and the nutrient solutions, which bathed the roots constantly, were aerated by bubbling air from an aquarium pump. One 5-gal container of nutrient solution supplied each five test plants. The plants were grown from seed to maturity and observed for symptoms of phytotoxicity at 0, 1, 10, 100, and 1000 ppm levels of either DIMP or DCPD.

One of the soil studies was conducted in three greenhouse rooms in which the seeds were planted in 3-gal, high-density polyethylene, black growth containers in Fullerton sandy loam using DIMP or DCPD as the contaminant. The concentrations of contaminant in the irrigation water used in these tests were 0, 1, 8 and 20 ppm. Another series of toxic range finding tests was conducted in soil in a separate greenhouse in which concentration levels of 0, 50, 100, 300, 500, 700, and 1000 ppm of the contaminants in the irrigation water were used.

The observation of phytotoxic symptoms including stunting of plants, leaf tip burn, and leaf necrosis in the hydroponic bath tests indicated that a phytotoxic

1 effect could be seen, in the case of DIMP, at a level between 10 and 100 ppm 1
 2 of DIMP. Severe tissue damage occurred in most plants above the 100-ppm 2
 3 level. In the DCPD series of plants only the 1000-ppm treatment produced 3
 4 substantial stunting of some plants. 4

5
 6 The weight of the plant tissues produced in the soil growth experiments was 5
 7 determined. The variation between plant weights was such that no unique 6
 8 symptoms of phytotoxic effect could be assigned to any given contaminant 7
 9 level or type indicating that 20 ppm was somewhat below an effect level for 8
 10 either chemical. 9
 11 10

12 Results of the second soil culture range-finding series of tests were compatible 11
 13 with the above conclusion in that at maturity the plants treated with 50 ppm 12
 14 DIMP were just beginning to show marginal symptoms of phytotoxicity and the 13
 15 DCPD plants showed no such symptoms at any of the test concentrations. 14
 16 15

17 The ability of the same plants used above to take up contaminants and con- 16
 18 centrate them in the plant tissues was measured by harvesting and analyzing 17
 19 the various tissues of the treated plants. In the case of DIMP contamination 18
 20 bioconcentration was demonstrated in all varieties of plant tested except for 19
 21 the juniper. The bioconcentration was centered chiefly in the leaves of the 20
 22 plants. Bioconcentration factor was defined as the concentration of contaminant 21
 22 in the living plant tissue divided by the concentration in the nutrient or irri- 22

23 gation liquid. With the exception of corn leaves, which are several times 23
 24 higher, these factors have a distribution for DIMP in the plants tested around 24
 25 20X and below. 25
 26 26

27
 28 The stems and roots generally show considerably less concentration than do 27
 29 the leaves. The DIMP in solution thus following the general water movement 28
 30 in the plant is somehow trapped in the leaves and accumulates there as the 29
 31 water is lost through the various transpiration mechanisms. The biocon- 30
 32 centration is in evidence in plants grown in both the hydroponic culture and 31
 33 the soil culture. 32
 34 33

35 No bioconcentration was demonstrated in the case of plants treated with DCPD. 34
 36 35

37 Another group of seeds of sugar beet, bean, wheat, alfalfa, and carrot was 36
 38 placed in contaminated soil and irrigated with water contaminated with 37
 39 various levels of DIMP and DCPD up to 1000 ppm. No reduction in the number 38
 40 of germinated seeds over a control group was noted. At 7 to 10 days post 39
 41 emergence the phytotoxic effect of the DIMP was noted in that leaf curl and 40
 42 necrosis were beginning to occur. The plants grown in the DCPD contaminant 41
 43 did not show these symptoms. 42
 44 43

1 The analytical method used for both contaminants was essentially the same
 2 and consisted of harvesting selected plant tissues, extraction by homogenizing
 3 them in a solvent, clarifying the solvent, and subjecting an aliquot of the
 4 extract to gas liquid chromatography. In the case of DIMP samples the
 5 chromatographic column eluate was directed to an alkaline flame ionization
 6 detector (AFID) which is extremely sensitive to phosphorus containing com-
 7 pounds. In the case of DCPD samples the column eluate was directed to a
 8 flame ionization detector (FID), which is a very sensitive detector for hydro-
 9 carbon compounds.

10
 11 Quantitative determinations were made by integrating the chromatographic
 12 peaks obtained and comparing peak areas from sample solutions with peak
 13 areas from standard solutions of DIMP and DCPD.

14
 15 Simultaneously with the phytotoxicity and bioconcentration studies on living
 16 plants the third area of interest under this contract was investigated. This
 17 study used 5-ft deep soil lysimeters as vehicles for determining the move-
 18 ment of DIMP through various types of soil as a function of the volume of
 19 irrigation water applied to their surfaces. The soils used in this study were
 20 obtained from various agricultural locations in California. These locations
 21 and the soil types obtained are as follows:

- | | | |
|----|--------------------------|----|
| 23 | Chino -- sandy clay loam | 23 |
| 24 | Brawley -- silty clay | 24 |
| 25 | Ventura -- clay loam | 25 |
| 26 | Fullerton -- sandy loam | 26 |
| 27 | Walnut -- clay loam | 27 |
| 28 | | 28 |
| 29 | | 29 |
| 30 | | 30 |

31 The lysimeters were fitted at various depths with ground water sampling
 32 tubes and were designed so that soil core samples could be taken through
 33 the entire depth of the soil column.

34
 35 The DIMP was applied to the lysimeter soil by two methods. The first con-
 36 sisted of placing a 2-in. deep layer of a solution of 20 ppm DIMP in distilled
 37 water on the surface of the lysimeter at regular intervals (weekly or biweekly)
 38 and allowing it to percolate down through the soil. Samples of this water
 39 were taken and analyzed on a weekly basis. Samples of the soil column
 40 were taken and analyzed on a monthly basis.

41
 42 The second type of application of DIMP consisted of mixing the DIMP to a
 43 level of 20 ppm with the top 1-ft depth of soil and then irrigating the soil
 44 with a 2-in. deep layer of distilled water on a regular basis (weekly or biweekly).

1 Sampling and analysis of the soil column followed in the same manner as in
2 the first group of lysimeters.

3
4 The analyses on the water samples were performed by direct injection of
5 an aliquot into a gas-liquid chromatograph fitted with an AFID detector
6 as in the case of the DIMP plants. The analysis of the soil samples consisted
7 of extracting DIMP from the soil by agitation with methanol solvent, clarify-
8 ing the solvent by settling or centrifugation and injection of an aliquot into
9 the same chromatographic system described above.

10
11 The total amount of water that drained through the lysimeter was collected,
12 measured, and analyzed for DIMP. The ratio of water drained off to water
13 applied was designated as drainage ratio. In the first type of test, chronic
14 application, this drainage ratio after 426 days averaged 55%. In the second
15 type, single contamination followed by distilled water leaching, after 322 days
16 the drainage ratio averaged 28%.

17
18 Calculating an average mass balance from the results of analyses of both the
19 soil and water fractions of the first and second types of lysimeters yielded
20 values for DIMP recovery of 48% and 36% respectively. These values are in
21 keeping with the recovery values for water.

22
23 The distribution of the DIMP recovered from the lysimeter samples depended
24 on its manner of application. The first group of lysimeters, chronic applica-
25 tion of contaminant, resulted in an accumulation of a thin layer on the surface
26 of the soil that was relatively concentrated in DIMP and a more dilute dis-
27 tribution throughout the remaining soil profile. The second group, distilled
28 water leaching of a mixture of DIMP in soil, resulted in the passage of a
29 slightly broadened band of DIMP downward through the soil column. From
30 an initial condition of a 0-12 in. depth of contamination in all cases, the
31 irrigation resulted in the following bands of contamination: Ventura cl -
32 24 - 60 in.; Chino scl - 24 - 60 in.; Fullerton sl - 36 - 60 in.; Walnut cl -
33 42 - 60 in.; Brawley, sc - 30 - 60 in. These results demonstrate, within
34 the sensitivity of the analytical system, the ability of the irrigation water to
35 wash a single DIMP contamination from a given soil matrix within the time
36 and volume parameters of the experiment.

37
38 A series of radioactive tracer experiments was performed to provide esti-
39 mates as to the vaporizability of DIMP and DCPD from soil mixtures. Radio-
40 active DIMP and DCPD, at 20 ppm levels, were intimately mixed with 4-in.
41 deep columns of dry and moist soil. These contaminated soil columns were
42 subjected to air flow across their surface for extended periods at the com-
43 pletion of which the entire soil columns were recovered and analyzed for
44 radioactivity content. Both the DIMP and DCPD dry soil retained over 95%

of the initial radioactivity after approximately 250 hr treatment. The moist soil samples lost somewhat more of their activity. In this case the DIMP recovery figure was 78% and the DCPD 62%. These figures indicate that evaporation of DIMP and DCPD from dry soil is not a significant mechanism of loss. The greater loss of material from the moist soil may be caused by weaker binding to wet soil or an enhanced rate of decomposition. Further experimentation will be needed to determine this mechanism.

1
2
3
4
5
6
7
8
9
10
11
12
13
14
15
16
17
18
19
20
21
22
23
24
25
26
27
28
29
30
31
32
33
34
35
36
37
38
39
40
41
42
43
44

1
2
3
4
5
6
7
8
9
10
11
12
13
14
15
16
17
18
19
20
21
22
23
24
25
26
27
28
29
30
31
32
33
34
35
36
37
38
39
40
41
42
43
44

REPORT DOCUMENTATION PAGE		READ INSTRUCTIONS BEFORE COMPLETING FORM
1. REPORT NUMBER 1953-01(01)FP	2. GOVT ACCESSION NO.	3. RECIPIENT'S CATALOG NUMBER
4. TITLE (and Subtitle) Investigations of the Environmental Fate and Phytotoxicity of DIMP and DCPD		5. TYPE OF REPORT & PERIOD COVERED Final Report
		6. PERFORMING ORG. REPORT NUMBER
7. AUTHOR(s) P. A. O'Donovan, J. E. Woodward		8. CONTRACT OR GRANT NUMBER(s) DAMD-17-75-C-5069
9. PERFORMING ORGANIZATION NAME AND ADDRESS Aerojet Ordnance and Manufacturing Company 9236 East Hall Road Downey, California 90241		10. PROGRAM ELEMENT, PROJECT, TASK AREA & WORK UNIT NUMBERS
11. CONTROLLING OFFICE NAME AND ADDRESS		12. REPORT DATE June 1977
		13. NUMBER OF PAGES 154
14. MONITORING AGENCY NAME & ADDRESS (if different from Controlling Office) USA Medical Research and Development Command Washington, D. C. 20314		15. SECURITY CLASS. (of this report) Unclassified
		15a. DECLASSIFICATION/DOWNGRADING SCHEDULE
16. DISTRIBUTION STATEMENT (of this Report) Approved for Public Release; Distribution Unlimited		
17. DISTRIBUTION STATEMENT (of the abstract entered in Block 20, if different from Report)		
18. SUPPLEMENTARY NOTES		
19. KEY WORDS (Continue on reverse side if necessary and identify by block number) Diisopropyl methyl phosphonate, dicyclopentadiene, phytotoxicity, plant contamination, bioconcentration of chemicals in plants and soil.		
20. ABSTRACT (Continue on reverse side if necessary and identify by block number) The objective was to study three aspects of the problem of contaminant chemicals in the soil of Rocky Mountain Arsenal, Colorado in particular and other soils in general: (1) the determination of concentration levels of the contaminants that would produce phytotoxic symptoms in plants, (2) establishing the existence and degree of the bioconcentration of these chemicals in the plants, and (3) a study of the stability or movement of these chemicals in various types of soil with two methods of application.		

1
2
3
4
5
6
7
8
9
10
11
12
13
14
15
16
17
18
19
20
21
22
23
24
25
26
27
28
29
30
31
32
33
34
35
36
37
38
39
40
41
42
43
44

1
2
3
4
5
6
7
8
9
10
11
12
13
14
15
16
17
18
19
20
21
22
23
24
25
26
27
28
29
30
31
32
33
34
35
36
37
38
39
40
41
42
43
44

FOREWORD

Aerojet Ordnance and Manufacturing Company (AOMC) submits this final report in partial fulfillment of Contract DAMD-17-75C-5069, Determination of Decontamination Criteria, DIMP and DCPD. This contract is performed under the sponsorship of the United States Army Medical Research and Development Command.

The authors wish to express their gratitude to Mr. David W. Huber for his invaluable assistance in all of the experimental operations of this project.

TABLE OF CONTENTS

Section		Page
1	INTRODUCTION	1
2	PLANT STUDIES	4
2.1	Objectives	4
2.2	Materials and Methods	4
2.3	Results	29
2.4	Discussion	72
3	SOIL STUDIES	76
3.1	Objectives	76
3.2	Materials and Methods	76
3.3	Results	91
3.4	Discussion	103
4.	CONCLUSIONS	110
4.1	DIMP	110
4.2	DCPD	112
	APPENDIX A -- DIMP and DCPD Concentrations in Plants	115
	APPENDIX B -- DIMP and DCPD Concentrations in Soil and Water	125

LIST OF ILLUSTRATIONS

Figure		Page
1	Program Schedule	3
2	Setup of Hydroponic Baths for Range Finding Experiments . . .	6
3	Polyethylene Container Arrangement	7
4	Assembled Container Apparatus	7
5	AOMC Chino Hills Facility	9
6	Active Plant Containers -- DCPD Room	10
7	Soil Culture Greenhouses	13
8	Greenhouse Evaporative Coolers	14
9	Greenhouse Space Heaters	15
10	Arrangement of Plants for Soil Culture Experiments	16
11	Coring Tool	19
12	Varian Model 1840-1 Gas-Liquid Chromatograph Used for Trace Analyses	22
13	Chromatogram of DIMP in Methanol	23
13	Chromatogram of DIMP in Methanol	24
14	Chromatogram of DCPD in Chloroform, Dilute	25
15	Chromatogram of DCPD in Chloroform	26
16	DCPD Sample in Carbon Disulfide	28
17	Examples of Variable Effects of DIMP Concentrations on Plant Tissue	30
18	Comparison of Tomato Plants: Not Exposed to DIMP Nutrient Bath (L); Exposed to DIMP Nutrient Bath (R)	31
19	Effects of DIMP on Juniper Plant	33
20	Effects of DIMP on Corn Seedling After 2 Weeks	35
21	Effects of DCPD on Corn Seedling After 2 Months	35
22	Effects of DIMP on Sugar Beets	36
23	Effects of DCPD on Sugar Beets	36
24	Effects of DIMP-Contaminated Soil on Plants	38
25	Portion of Greenhouse Plants in 0-1000 ppm Range Finding Experiments	39
26	Yield of Radish Plants from Various Levels of DCPD Contamination	40
27	Yield of Radish Plants from Various Nutrient Levels of DIMP Contamination	41
28	Effect of Dose Level of DCPD on Yield of Various Plants . . .	44
29	Effect of Dose Level of DIMP on Yield of Various Plants . . .	45
30	Average Yield of Sugar Beets Irrigated with DIMP or DCPD Contaminated Water	51
31	Average Yield of Alfalfa Irrigated with DIMP or DCPD Contaminated Water	52

LIST OF ILLUSTRATIONS (Continued)

Figure		Page
32	Average Yield of Carrots Irrigated with DIMF or DCPD Contaminated Water	53
33	Average Yield of Beans Irrigated with DIMF or DCPD Contaminated Water	54
34	Bioconcentration of DIMF in Tomato Leaves	57
35	Bioconcentration of DIMF in Hydroponically Grown Plant Tissues (1)	58
36	Bioconcentration of DIMF in Hydroponically Grown Plant Tissues (2)	59
37	AOMC Lysimeter Setup	77
38	Lysimeter Cover	78
39	Lysimeter Stand	79
40	Tensiometer Tubing	81
41	Geographic Location of AOMC Lysimeter Samples	82
42	Textural Classification of Soils	85
43	Laboratory Arrangement for Determining Evaporative Loss of Chemicals from Soil	88
44	Laboratory Test Setup	89
45	Drainage Ratios of Various Soils in Full-Scale Lysimeter Tests, Group 1	93
46	Drainage Ratios of Various Soils in Full-Scale Lysimeter Tests, Group 2	101

LIST OF TABLES

Table		Page
1	Physical Properties of Contaminant Chemicals	1
2	Hoagland's Nutrient Solution No. 2	5
3	Plant Appearance After 44 Days, Exposure to DIMP	32
4	Yield of Radish Plants from Various Nutrient Levels of Contamination	42
5	Yield of Tomato Plants From Various Nutrient Levels of Contamination -- 150 Days	42
6	Yield of Harvestable Portion of Plants	46
7	Average Weight of Plant Parts in Soil Culture at 201 Days	47
8	Soil Analysis for DIMP From Sugar Beet Test Pots (After 210-Day Irrigation)	55
9	Hydroponic Tomato Leaf Bioconcentration Factors (DIMP) -- Fresh-Cut Basis	56
10	DIMP Content of Plant Parts from 1000 ppm Nutrient -- 22 to 25 Day Exposure	60
11	DIMP Content of Radish Parts After 28-Day Exposure	62
12	DIMP Uptake in Bean Plants after 48-Day Exposure Bioconcentration Factor	63
13	Percent Moisture of Harvested Plant Leaves on Day 96	63
14	Bioconcentration of DIMP in Harvested Tomato Plant Parts -- 149 Days from Original Inoculation	64
15	Bioconcentration of DIMP by Plant Parts in 20ppm Irrigation -- 37 days from Original Inoculation	65
16	Bioconcentration of DIMP in Plant Parts -- 65 Days from 20-ppm Initial Inoculation	66
17	Bioconcentration of DIMP in Plant Parts -- 65 Days from 8-ppm Initial Inoculation	67
18	Bioconcentration of DIMP in Plant Parts -- 65 Days from 1-ppm Initial Inoculation	68
19	Bioconcentration of DIMP by Plant Parts (Terminal)	69
20	Characterization of Lysimeter Sample Soils	83
21	Spectrographic Analyses of Top Soil Samples	84
22	Lysimeter Drainage Ratios, Group 1	92
23	DIMP Content of Tensiometer Water Samples (Group 1) at 405 Days (ppm)	94
24	Average DIMP Content of Soil Samples (ppm) After 426 Days, Group 1	95

LIST OF TABLES (Continued)

1 2 3 4 5 6 7 8 9 10 11 12 13 14 15 16 17 18 19 20 21 22 23 24 25 26 27 28 29 30 31 32 33 34 35 36 37 38 39 40 41 42 43 44	Table	Page	1 2 3 4 5 6 7 8 9 10 11 12 13 14 15 16 17 18 19 20 21 22 23 24 25 26 27 28 29 30 31 32 33 34 35 36 37 38 39 40 41 42 43 44	
	25	Material Balance, Lysimeter Group -- 426 Days	96	
	26	DIMP Concentration in 60-in. Drain Samples, Group 1	97	
	27	Percent Loss on Drying of Soil from East Lysimeters, Group 1 -- 207 Days from Original Inoculation	98	
	28	DIMP Content of Ground Water Samples at 315 Days (ppm), Group 2	99	
	29	Drainage Ratios, Group 2	100	
	30	Average DIMP Content of Soil Samples (ppm) After 322 Days, Group 2	102	
	31	Material Balance, Lysimeter Group 2, 322 Days	103	
	32	Percent Moisture in Soil of Group 2 Lysimeters 84 Days from Original Inoculation	104	
	33	Recovery of Radioactive Tracers from DIMP Experi- ments in Fullerton Soil (Dry)	105	
	34	Recovery of Radioactive Tracers from DCPD Experi- ments in Fullerton Soil (Dry)	106	
	35	Recovery of Radioactive Tracers from DIMP Experiments in Fullerton Soil (Wet)	107	
	36	Recovery of Radioactive Tracers from DCPD Experiments in Fullerton Soil (Wet)	108	

Section 1

INTRODUCTION

Approximately 2 years ago AOMC, under the sponsorship of the U.S. Army Medical Research and Development Command, began investigations of certain growing plants and their ability to absorb and concentrate certain soil contaminants. The two contaminants of interest are those shown to have been present in environmental samples taken at Rocky Mountain Arsenal (RMA), Colorado. These compounds are diisopropylmethyl phosphonate (DIMP) and dicyclopentadiene (DCPD). The structural formulas for these compounds are as follows:

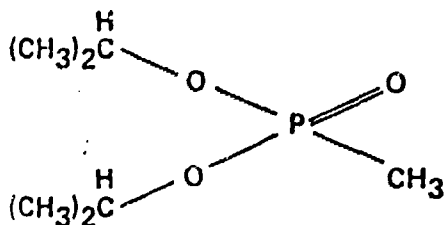

DIMP

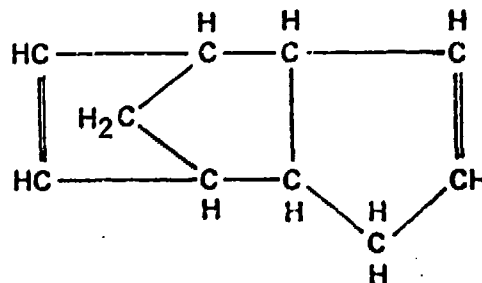

DCPD

Physical properties of the two contaminant compounds used in this study were provided by USAMBRDL and are shown in Table 1.

Table 1. Physical Properties of Contaminant Chemicals

Item	DIMP	DCPD
Density, g/cc	0.976 ²⁰	0.982 ²⁰
Melting point, °C	-	32
Solubility in H ₂ O	11g/liter at 80°C 1-2g/liter at 25°C	Insoluble
Temperature °C for cited vapor pressure mm Hg		
10	-77	47.6
100	-122	105
760	174	166.6

1 DIMP is present as a contaminant from the nerve agent production which was 1
2 formerly conducted at this site. The DCPD is used in the production of pes- 2
3 ticides by a commercial firm which uses plant facilities at RMA. USAMBRDL 3
4 project management provided the information that these two compounds are 4
5 documented contaminants in RMA soils and ground water presumably because 5
6 of past, unsatisfactory, waste disposal practices. 6

7
8 AOMC showed that DIMP could be detected in naturally occurring plants and 8
9 soil that were known to have been contaminated as long as 6 years before 9
10 analysis. Some of the soil areas used in the study had been subjected to 10
11 standard decontamination procedures at the time of the contamination (clas- 11
12 sified study). 12

13
14 The work on this contract was designed to investigate three aspects of the 14
15 problem: (1) Determine the bioconcentration of the compounds in the plants, 15
16 (2) observe phytotoxicity symptoms caused by the compounds, and (3) deter- 16
17 mine the environmental fate (accumulation, translocation, or transformation 17
18 of the compounds) in soils. 18

19
20 The schedule for this program is shown in Figure 1. 20
21
22

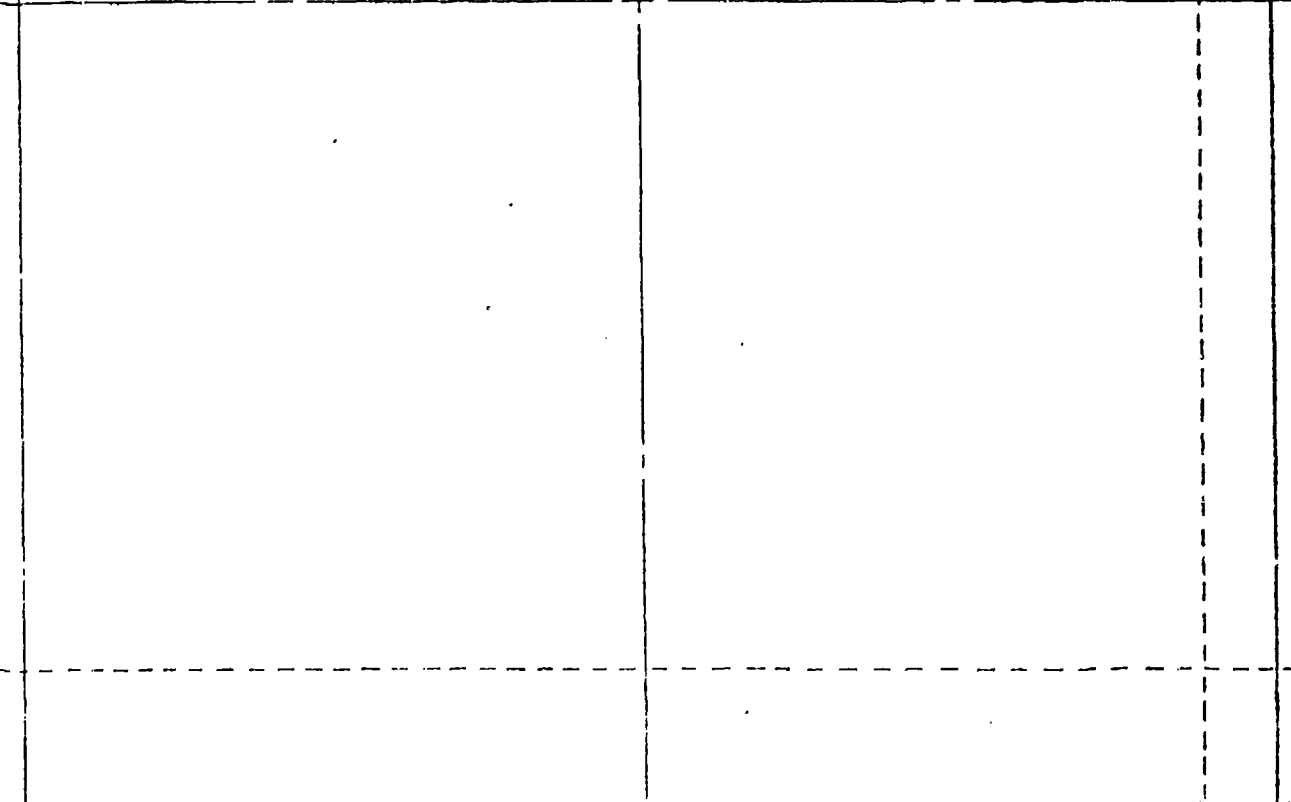

1
2
3
4
5
6
7
8
9
10
11
12
13
14
15
16
17
18
19
20
21
22
23
24
25
26
27
28
29
30
31
32
33
34
35
36
37
38
39
40
41
42
43
44

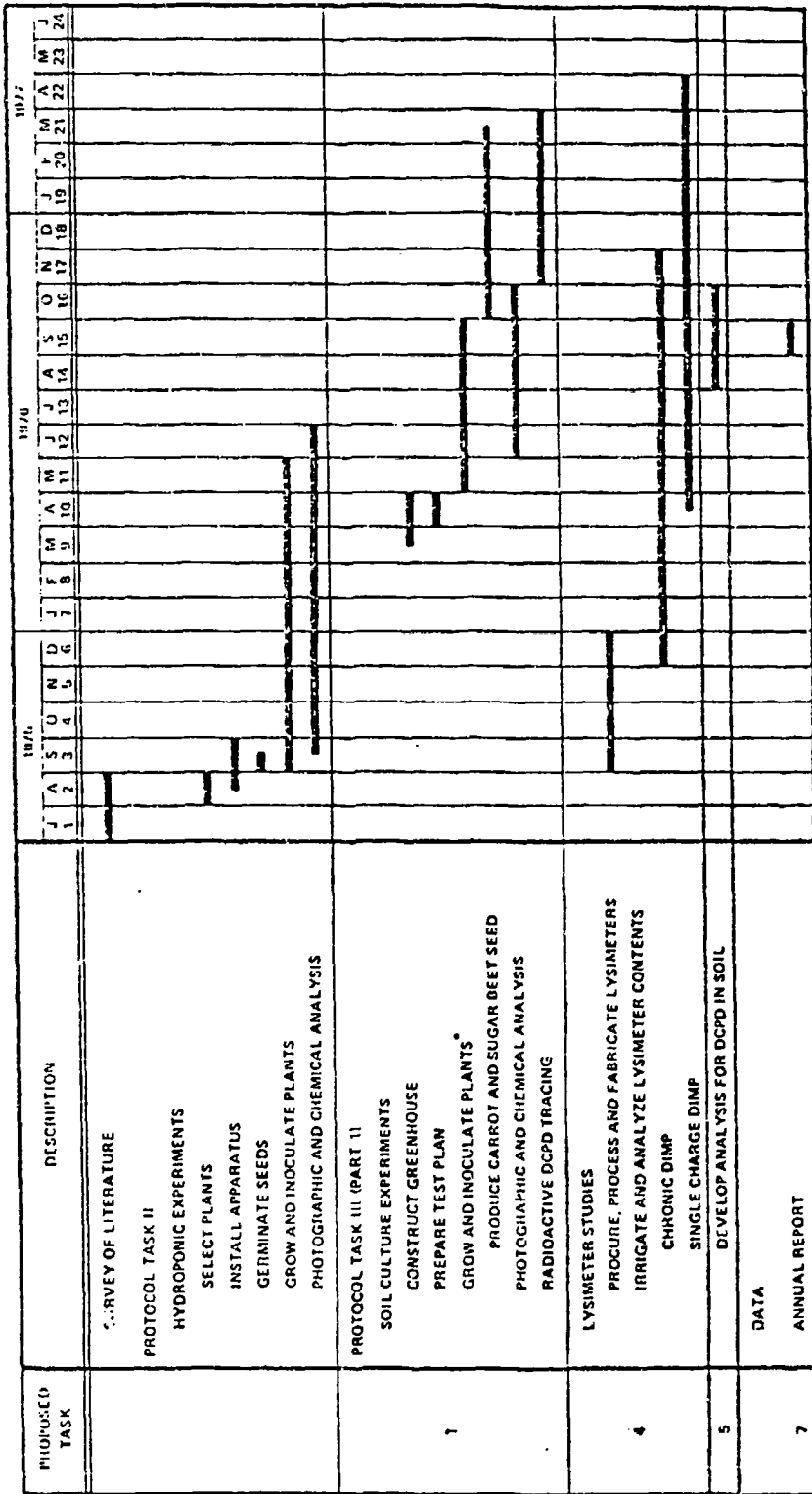

POSSIBLE SLIPPAGE POINT. ADJUSTMENT OF CONTAMINANT AT THIS POINT SHIFTS ALL FOLLOWING PLANT WORK TO THE RIGHT.

Figure 1. Program Schedule.

1
2
3
4
5
6
7
8
9
10
11
12
13
14
15
16
17
18
19
20
21
22
23
24
25
26
27
28
29
30
31
32
33
34
35
36
37
38
39
40
41
42
43
44

Section 2

PLANT STUDIES

2.1 OBJECTIVES

The objectives of the plant studies were to screen a relatively large series of plants in hydroponic culture to determine if plant uptake and phytotoxicity symptoms result from exposure to DIMP or DCPD at a relatively broad series of concentrations. This was to be accomplished by chemical analysis of the roots and foliage of the plants and observations of signs of phytotoxicity that appeared.

Positive results in the hydroponic plant studies dictated that more precise data should be obtained for the establishment of dose-response curves (phytotoxicity) and bioconcentration ratios for the contaminants with selected plant species.

2.2 MATERIALS AND METHODS

2.2.1 Task 1: Compound Screening for Phytotoxicity (Hydroponics)

2.2.1.1 Test System and Experimental Design

In previous AOMC investigations a series of water culture plant growth experiments was conducted successfully in which the hydroponic baths served as a convenient method for inoculating the plants with contaminants. One advantage of this type of experiment is that the plants can be exposed to a known and relatively constant concentration of contaminant compound dissolved in the nutrient solution. For all of these experiments the nutrient solution used was Hoagland's No. 2, the formula for which is given in Table 2.

In these current experiments the plants were supported on a gravel base that was suspended in the nutrient solution in perforated polyethylene containers, which permitted the nutrient solution access to the plant roots. Figure 2 shows container arrangement in the nutrient tubs, and Figure 3 shows the perforated bottoms of the square cross-section polyethylene containers. Figure 4 shows the assembled apparatus. The support for the containers in which the nutrient solution was held consisted of a 10-gal rectangular

Table 2. Hoagland's Nutrient Solution No. 2.

Concentration of Stock (gm/liter)	Macronutrients		Final Nutrient Solution (ml/liter)
115	$\text{NH}_4\text{H}_2\text{PO}_4$	-- Ammonium Acid Phosphate	1
101	KNO_3	-- Potassium Nitrate	6
236	$\text{Ca}(\text{NO}_3)_2$	-- Calcium Nitrate	4
246	MgSO_2	-- Magnesium Sulfate	2
	Trace Elements (1 Liter Stock Solution)		
	H_3BO_3	-- Boric Acid	2.86 g
	$\text{MnCl}_2 \cdot 4\text{H}_2\text{O}$	-- Manganese Chloride	1.81
	$\text{ZnSO}_4 \cdot 7\text{H}_2\text{O}$	-- Zinc Sulfate	0.22
	$\text{CuSO}_4 \cdot 5\text{H}_2\text{O}$	-- Copper Sulfate	0.08
	$\text{H}_2\text{MOO}_4 \cdot \text{H}_2\text{O}$	-- Molybdic Acid	0.02
5	$\text{FeC}_6\text{H}_5\text{O}_7 \cdot \text{XH}_2\text{O}$	-- Iron Citrate	1

Note: The iron solution was added to the nutrient solution about twice a week to replace the iron that tended to precipitate out of solution.

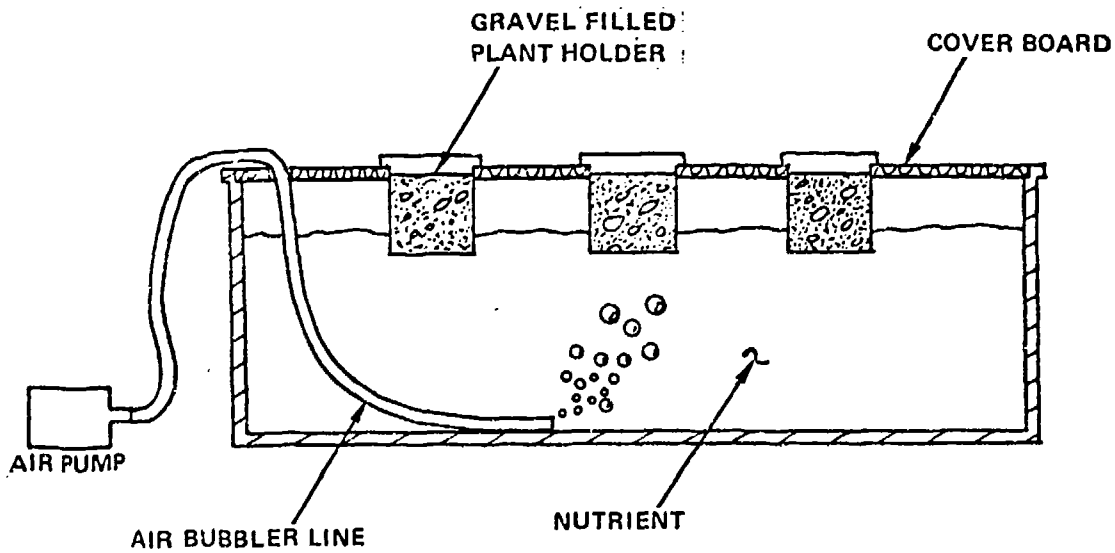
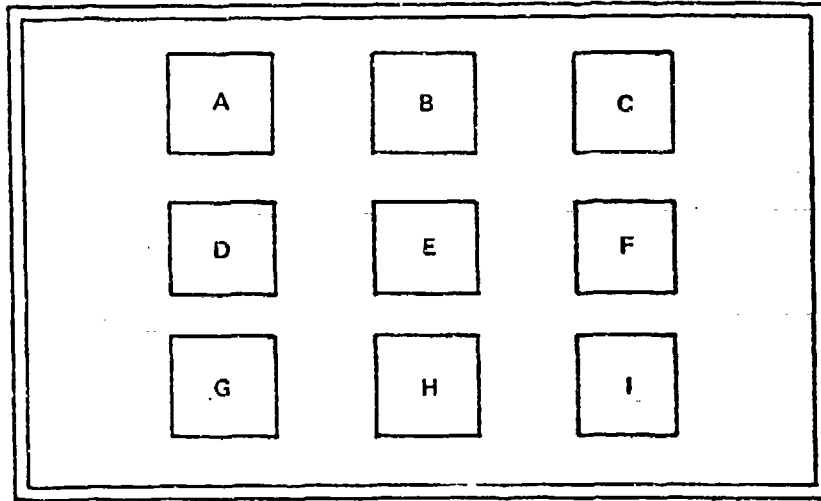

Figure 2. Setup of Hydroponic Baths for Range Finding Experiments.



Figure 3. Polyethylene Container Arrangement.

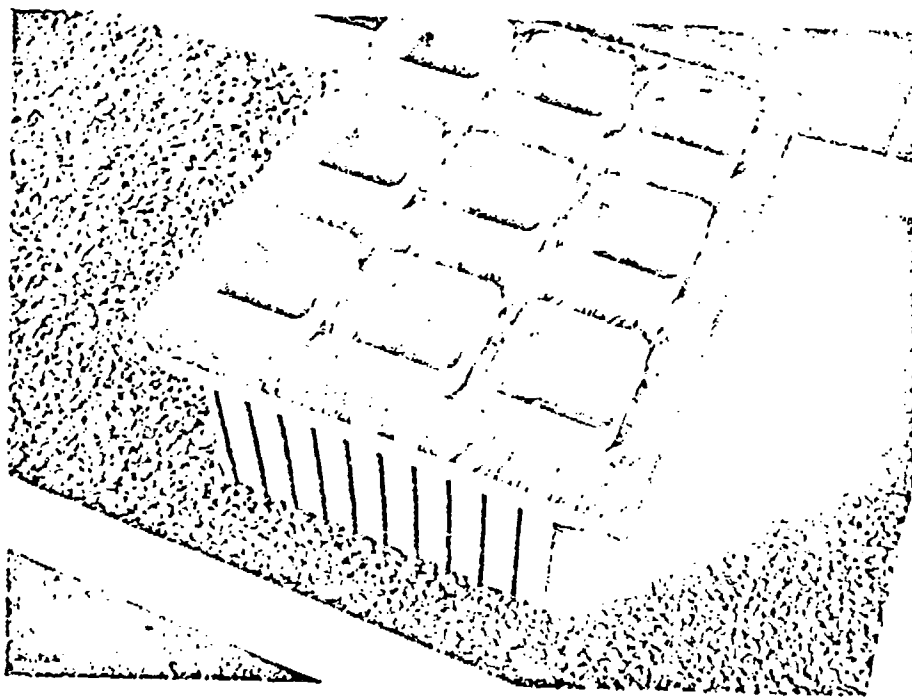

Figure 4. Assembled Container Apparatus.

1 polyethylene tub. The bath was aerated and agitated by a small aquarium
 2 pump that was run continuously; this forced air through a sparger suspended
 3 in the nutrient bath. 4

5 A series of 20 baths was assembled in a greenhouse, and various concentra-
 6 tions of the contaminant chemicals were added to the appropriate nutrient
 7 baths. Loss of agent chemicals, generally, was corrected for by analyzing
 8 the baths and bringing the concentration levels back to par on a 2-week cycle.
 9 As an extreme example of material loss, the baths that contained the mature
 10 tomato plants lost about 1 gal of nutrient solution per day. Lost volumes of
 11 liquid of this magnitude were replaced daily. 12

13 The DIMP and DCPD were maintained in separate greenhouse rooms to pre-
 14 vent cross-contamination by vapor. The greenhouses are located on the some-
 15 what remote test site near Chino, California. Figure 5 shows the green-
 16 house locations; the small community nearest the camera is Los Serranos,
 17 and the city at the base of the mountains is Pomona. A row of the active
 18 tubs in the DCPD room is shown in Figure 6. 19

20
 21 2.2.1.2 Plants 22

23 The first experiments were designed to discover the range of contaminant
 24 concentrations that would produce a phytotoxic effect in the plants. As such,
 25 an order of magnitude series of concentrations was chosen to bridge the
 26 effect/no effect level. These concentrations were 0, 1, 10, 100, and 1000
 27 parts per million (ppm) DIMP or DCPD in nutrient solution. 28

29 After germination tests showed that the plants would all be viable in the
 30 hydroponic system, samples of the following ten species were planted: 31

- 32 a. Corn -- improved golden bantam
- 33 b. Beans -- stringless green pod, bush
- 34 c. Radish -- early scarlet globe
- 35 d. Wheat -- Inia
- 36 e. Tomato -- red cherry
- 37 f. Carrot -- Danvers half long
- 38 g. Sugar beet -- Beta vulgaris
- 39 h. Meadow fescue -- Festuca elatior
- 40 i. Rose
- 41 j. Juniper -- Tamarix

7
10
11
12
13
14
15
16
17
18
19
20
21
22
23
24
25
26
27
28
29
30
31
32
33
34
35
36
37
38
39
40
41
42

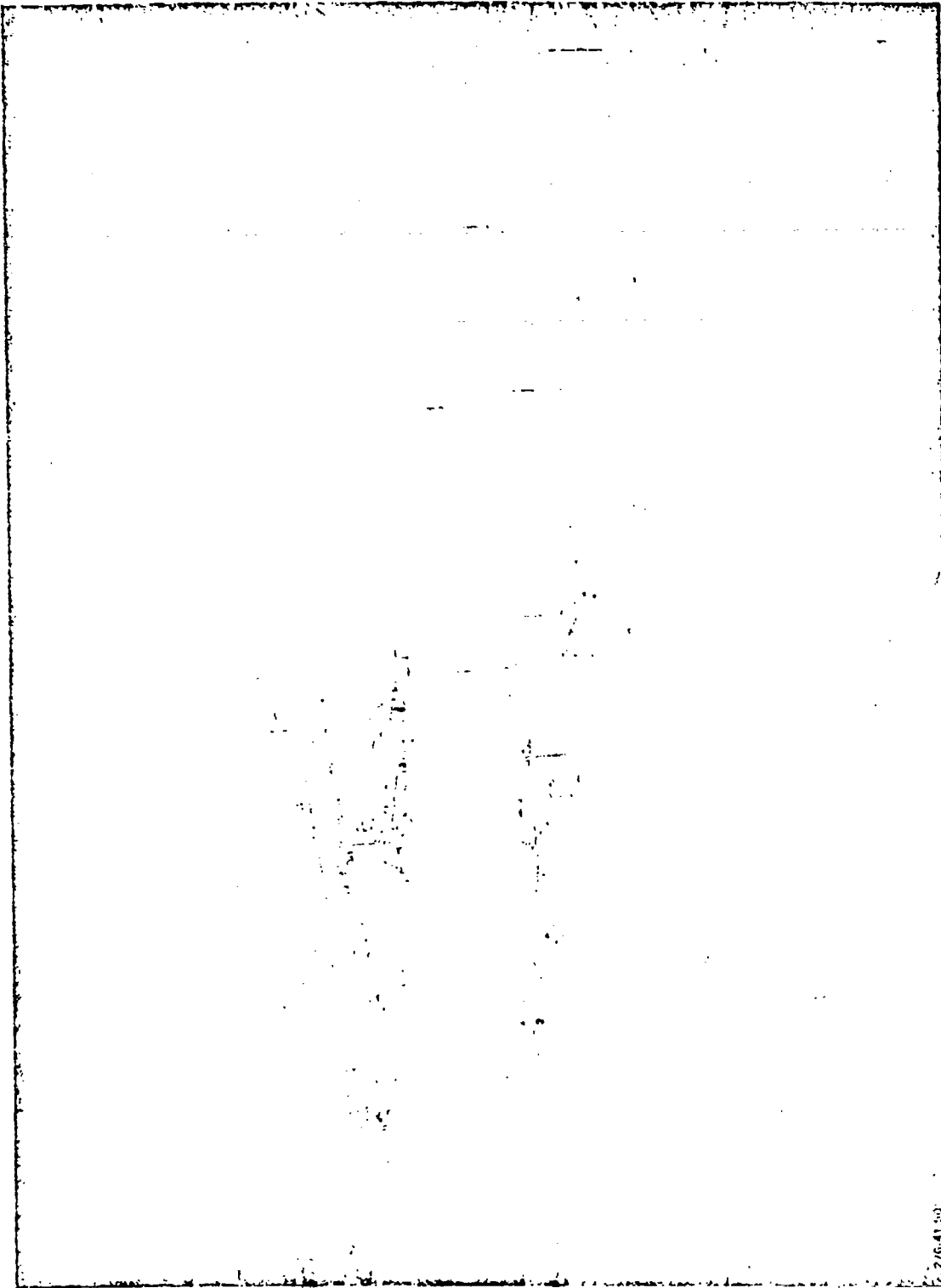

2
3
4
5
6
7
8
9
10
11
12
13
14
15
16
17
18
19
20
21
22
23
24
25
26
27
28
29
30
31
32
33
34
35
36
37
38

Figure 5. AOMC Chino Hills Facility.

- 7
- 8
- 9
- 10
- 11
- 12
- 13
- 14
- 15
- 16
- 17
- 18
- 19
- 20
- 21
- 22
- 23
- 24
- 25
- 26
- 27
- 28
- 29
- 30
- 31
- 32
- 33
- 34
- 35
- 36
- 37
- 38
- 9

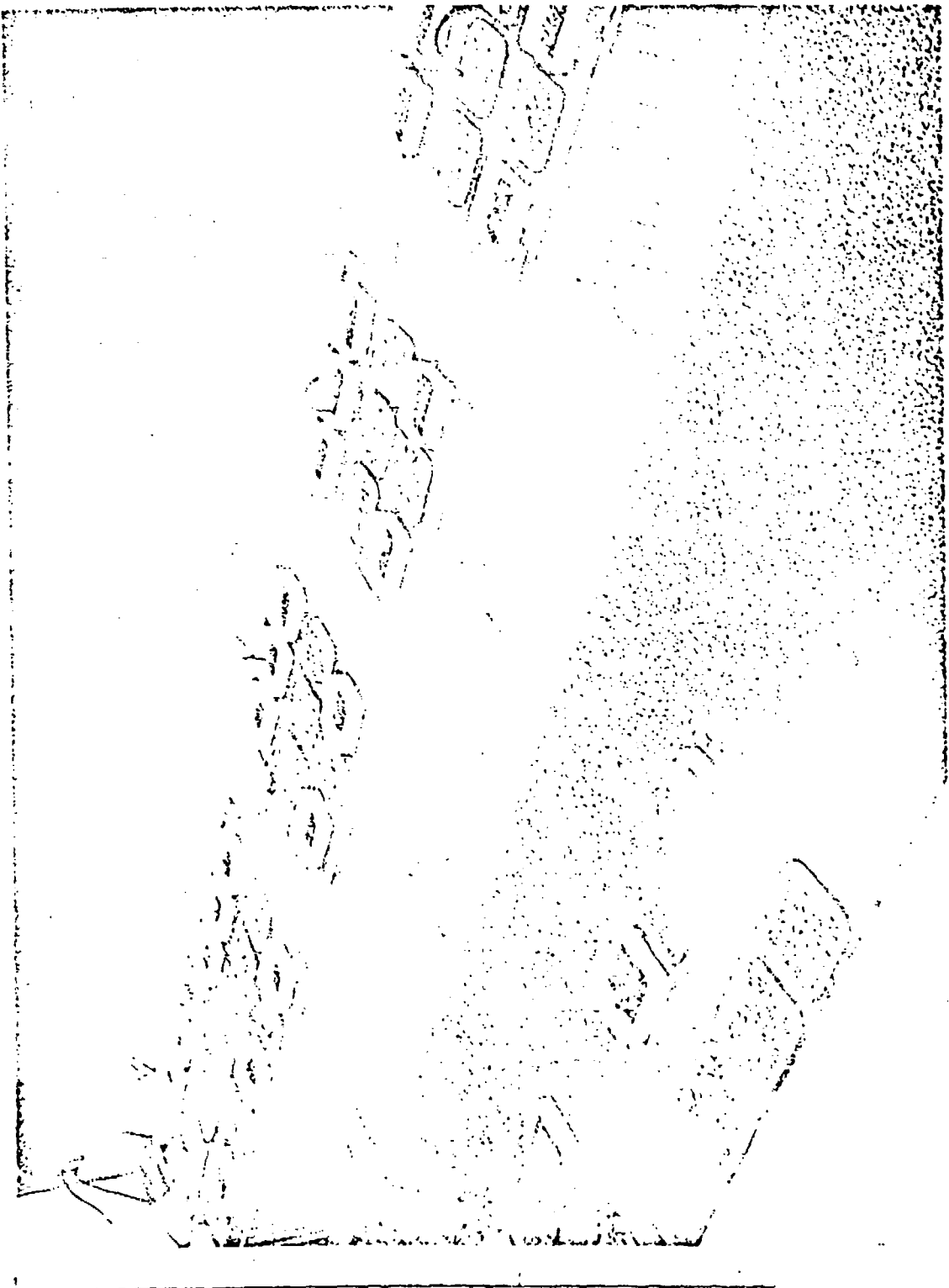

Figure 6. Active Plant Containers -- DCPD Room.

- 1
- 2
- 3
- 4
- 5
- 6
- 7
- 8
- 9
- 10
- 11
- 12
- 13
- 14
- 15
- 16
- 17
- 18
- 19
- 20
- 21
- 22
- 23
- 24
- 25
- 26
- 27
- 28
- 29
- 30
- 31
- 32
- 33
- 34
- 35
- 36
- 37
- 38
- 39
- 40
- 41
- 42
- 43
- 44

1	2.2.1.3 Sampling	1
2		2
3	During the first 2 to 3 week period following inoculation of the hydroponic	3
4	baths the plants in the 1000 ppm (part-per-million) DIMP baths, with the	4
5	exception of the juniper, were in poor condition; these entire plants were	5
6	harvested; separated into leaf, root, and stem; and subjected to analysis.	6
7	Those plants in the lesser concentrations of DIMP were large enough that	7
8	small portions (< 1gm) of leaf tissue were taken, blended and subjected to	8
9	analysis at various durations of exposure. At the conclusion of the experi-	9
10	ment for each plant type the entire plant was harvested, dissected into its	10
11	parts, and analyzed for the contaminant compound.	11
12		12
13	The tissues to be analyzed were cut by scissors from the main portion of	13
14	the plant, rinsed with distilled water to remove surface contamination, cut	14
15	into small pieces (typical 0.1 gm) and homogenized with solvent in a tissue	15
16	grinder (Pyrex No. 7725) fitted to a 1/4 in. electric drill motor. The homo-	16
17	genized solvent/tissue mix was then brought to volume, transferred to a	17
18	centrifuge tube, and centrifuged if necessary before injection into the chroma-	18
19	tograph.	19
20		20
21	The hydroponic nutrient solution containing DIMP was sampled by pipetting	21
22	from the nutrient bath which was kept homogenized by the constant bubbling	22
23	of the air spargers. This sample was then diluted if necessary with dis-	23
24	tilled water and injected directly into the chromatograph.	24
25		25
26		26
27	2.2.1.4 Observations and Measurements	27
28		28
29	The plants grown in the hydroponic screening experiments were observed for	29
30	changes in morphology as evidenced in particular by discoloration of foliage	30
31	and stunting or enhancement of growth compared to control plants, the latter	31
32	effect being evaluated both by visual observation of all the plants and deter-	32
33	mination of total mass of selected mature plants. The visual observations	33
34	of plant condition were supplemented by intermittent color photography of the	34
35	plants.	35
36		36
37		37
38	2.2.1.5 Data Analysis	38
39		39
40	Data from the hydroponic phytotoxicity study takes two forms. The first is	40
41	a visual comparison of treated and untreated plants as to their growth patterns	41
42	and tissue condition as a function of contaminant concentration. These obser-	42
43	vations by definition are somewhat subjective and treated as such. The	43
44	second is to select plants from the hydroponic baths and harvest, dissect,	44

and weigh them. These weights were tabulated and plotted as functions of contaminant concentration. Empirical relationships were noted.

2.2.2 Task II: Definite Compound Testing for Phytotoxicity (Soil)

2.2.2.1 Test System and Experimental Design

The purpose of these experiments was to determine if various plant species, when grown from seeds in soil culture, would take up known contaminants and show symptoms of phytotoxicity. A select group of plant species from among those run in the hydroponic system were used. Figure 7 shows the greenhouse in which these experiments were performed. It consists of three isolated rooms, each with its own air conditioning system of evaporative coolers (Figure 8) and space heaters (Figure 9) with associated individual thermostatic controls. This greenhouse is located adjacent to the greenhouse used in the hydroponic experiments (Section 2.2.1.1).

The experimental method used consisted of growing the plants from seeds in 3-gal high density, black polyethylene flower pots, irrigating them with contaminated water, chemically measuring the uptake of contaminants in the various portions of the plant, and making visual and photographic observations of the plant parts as they matured.

The soil used for these growth tests was Fullerton sandy loam, characteristics of which are as follows:

pH	Organic Matter (%)	Sand (%)	Silt (%)	Clay (%)	Moisture Capacity (%)	Exchange Capacity (me/100 gm) (pH 7)
6.9	2.2	60	22	18	44.5	16.6

The irrigating solutions consisted of distilled water with 1 ppm, 8 ppm, and 20 ppm of the contaminant respectively. Several seeds were planted in each pot for reliability of germination and to provide excess samples for photographic study. One room in the greenhouse was used for DIMP exposures, one for DCPD exposures, and one for controls. The general layout of the experiment using four replicates of five plants and three concentrations is shown in Figure 10.

8
9
10
11
12
13
14
15
16
17
18
19
20
21
22
23
24
25
26
27
28
29
30
31
32
33
34
35
36
37
38
39
40

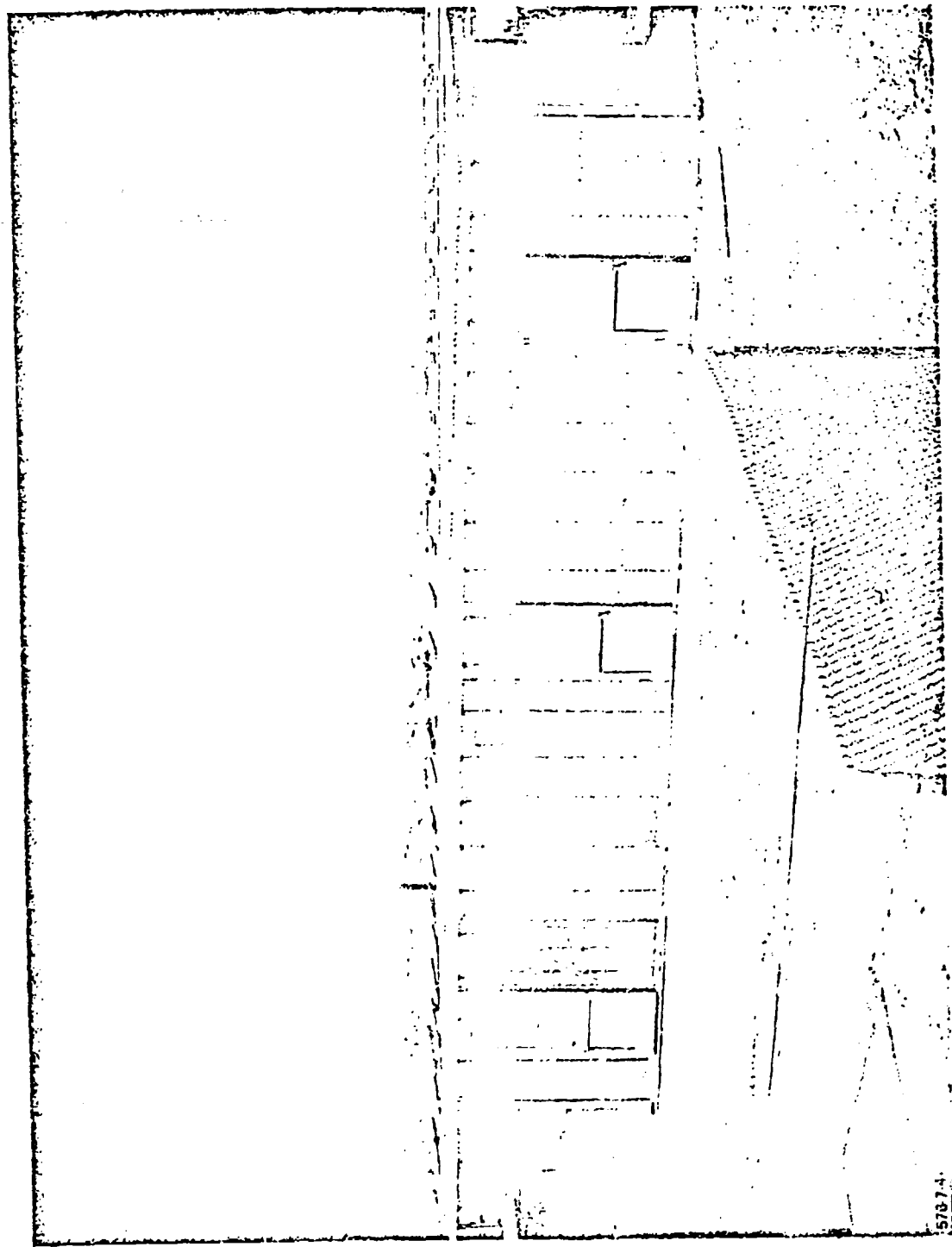

Figure 7. Soil Culture Greenhouses.

1
2
3
4
5
6
7
8
9
10
11
12
13
14
15
16
17
18
19
20
21
22
23
24
25
26
27
28
29
30
31
32
33
34
35
36
37
38
39
40
41
42
43
44

7
8
9
10
11
12
13
14
15
16
17
18
19
20
21
22
23
24
25
26
27
28
29
30
31
32
33
34
35
36
37
38

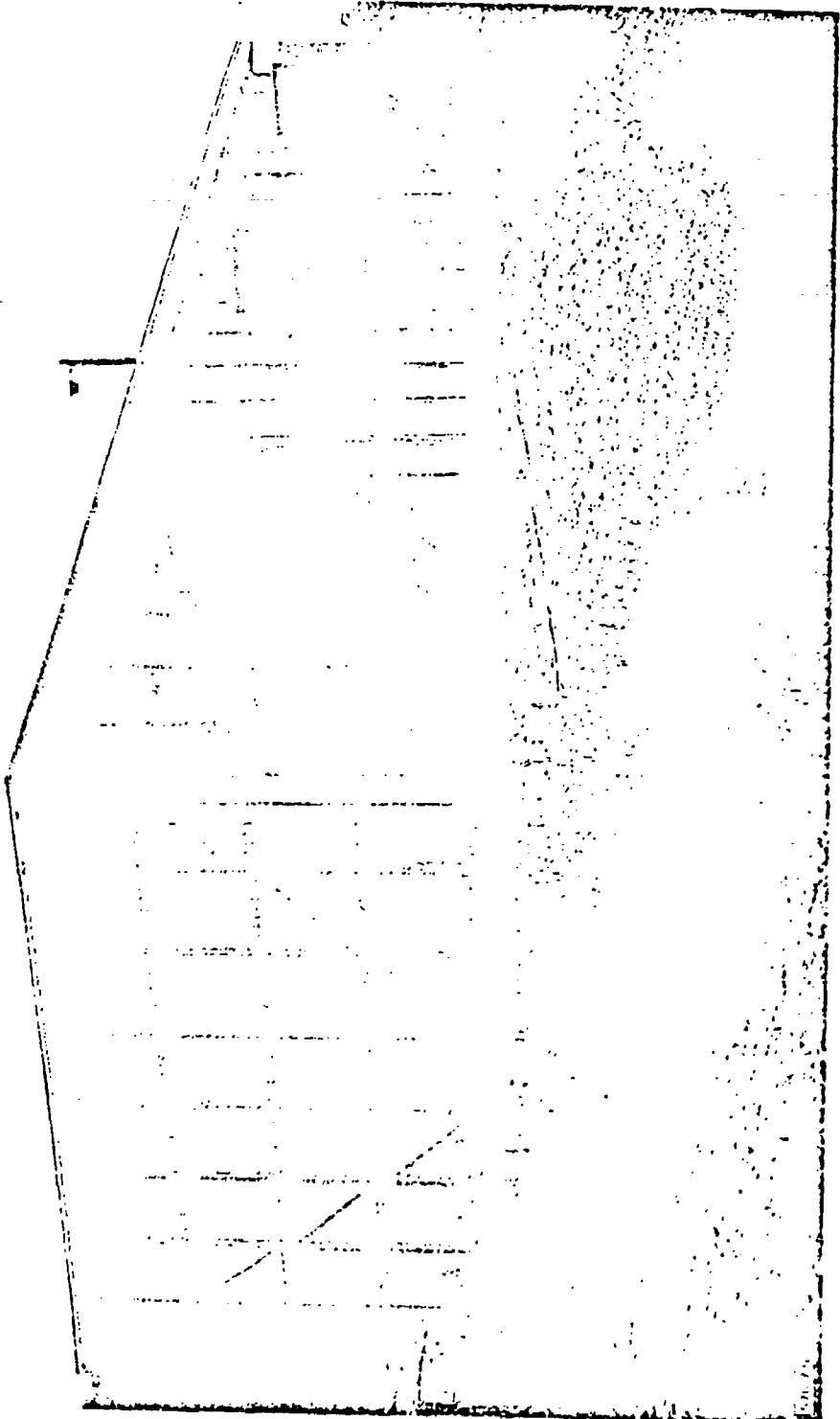

Figure 8. Greenhouse Evaporative Coolers.

1
2
3
4
5
6
7
8
9
10
11
12
13
14
15
16
17
18
19
20
21
22
23
24
25
26
27
28
29
30
31
32
33
34
35
36
37
38
39
40
41
42
43
44

1
2
3
4
5
6

9
10
11
12
13
14
15
16
17
18
19
20
21
22
23
24
25
26
27
28
29
30
31
32
33
34
35
36
37
38
39
40
41
42
43
44

1
2
3
4
5
6
7
8
9
10
11
12
13
14
15
16
17
18
19
20
21
22
23
24
25
26
27
28
29
30
31
32
33
34
35
36
37
38
39
40
41
42
43
44

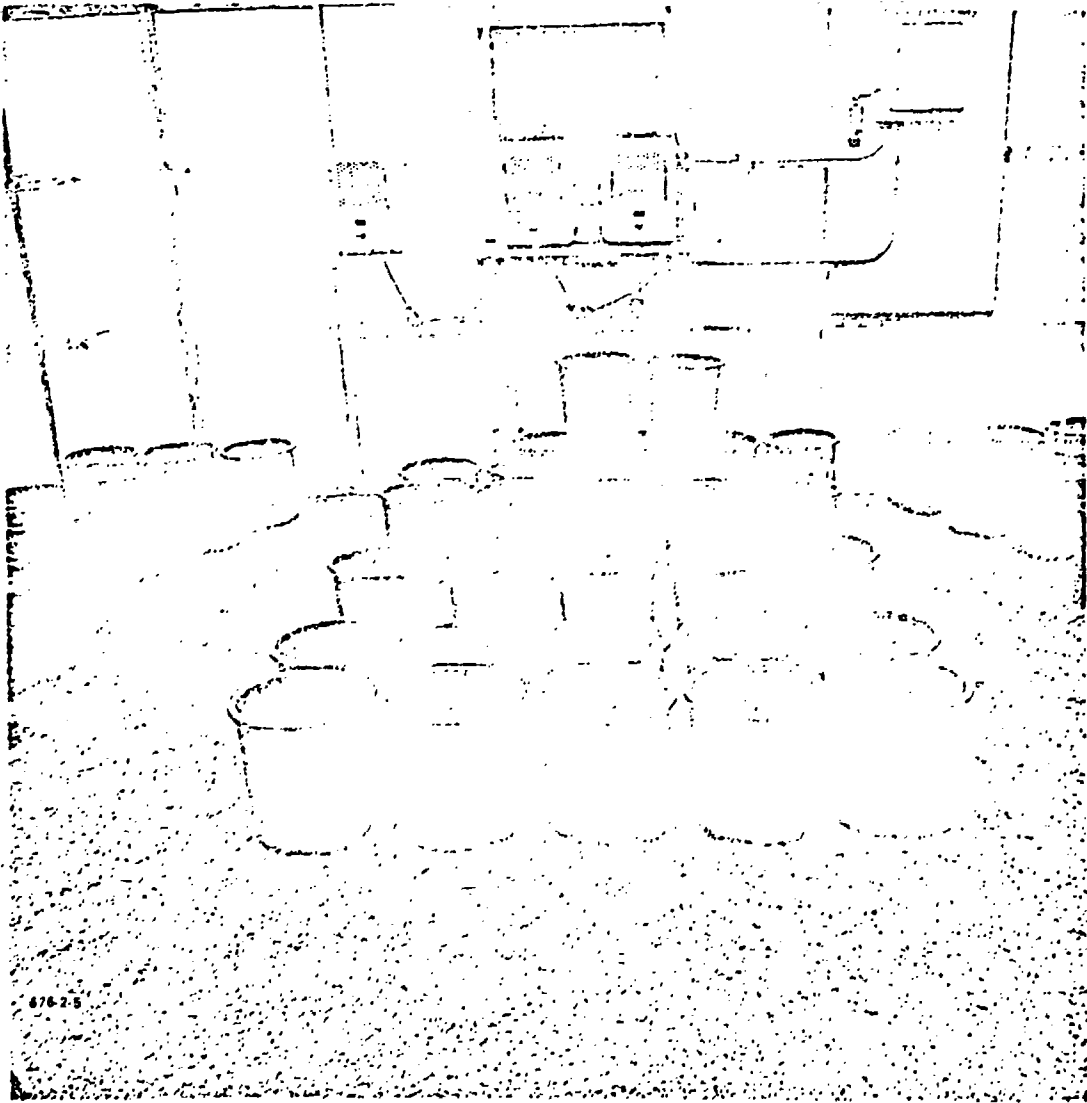
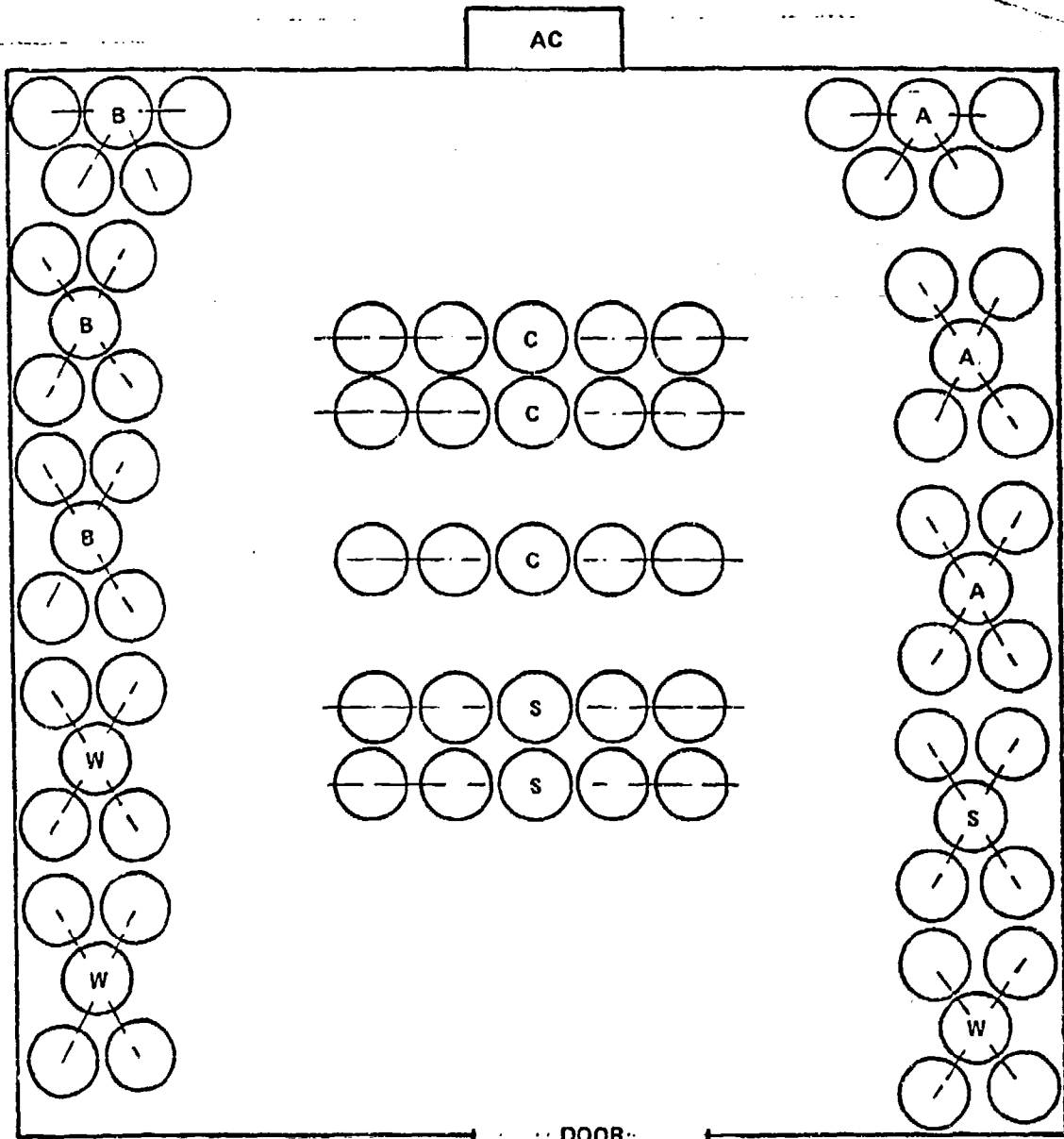

Figure 9. Greenhouse Space Heaters.

1
2
3
4
5
6
7
8
9
10
11
12
13
14
15
16
17
18
19
20
21
22
23
24
25
26
27
28
29
30
31
32
33
34
35
36
37
38
39
40
41
42
43
44

1
2
3
4
5
6
7
8
9
10
11
12
13
14
15
16
17
18
19
20
21
22
23
24
25
26
27
28
29
30
31
32
33
34
35
36
37
38
39
40
41
42
43
44



- A - ALFALFA
- B - BEAN
- C - CARROT
- S - SUGAR BEET
- W - WHEAT

Figure 10. Arrangement of Plants for Soil Culture Experiments.

1 Initially four seeds or groups of seeds were planted in each pot to provide
 2 redundancy for germination as well as immature subjects for photographic
 3 study. 4

5 There are three categories of plants in these experiments. The terminology
 6 used here refers to negative controls, positive controls, and active plants.
 7 Negative controls are the plants grown in "isolation" in the central room of
 8 the greenhouse where no contaminant is ever introduced. Positive controls
 9 are plants grown adjacent to and in the same room as the plants receiving
 10 contaminated irrigation water but are irrigated with only distilled water.
 11 Active plants have irrigation water contaminated with the appropriate chem-
 12 ical (DIMP or DCPD). 13

14 Simultaneously with the 1, 8, and 20 ppm soil media study a series of range
 15 finding tests was run in an adjoining greenhouse encompassing concentrations
 16 of 0, 50, 100, 300, 500, 700, and 1000 ppm DIMP and DCPD. One added
 17 objective of these tests was to have a backup study underway in the event
 18 that the 1, 8, and 20 ppm contaminant concentrations were less effective
 19 in the soil than in the hydroponic media. 20

21 Using the same experimental apparatus and procedures another series of tests
 22 was undertaken in which seeds were planted in soil which had previously been
 23 moistened with the same concentrations of contaminant as above and were
 24 irrigated with those contaminants during and after the germination period. 25

26
 27 2.2.2.2 Plant Species 28

29 The plants used in this study included 30

- 31 a. Wheat -- Inia 31
- 32 b. Sugar beet -- beta vulgaris 32
- 33 c. Alfalfa -- medicago sativa 33
- 34 d. Bean -- stringless green pod, bush 34
- 35 e. Carrot -- Danvers half long. 35

36
 37 The criteria for selecting these plants included (1) economic interest in the
 38 Rocky Mountain area in wheat and sugar beets, (2) alfalfa being a nearly
 39 universal forage crop, (3) the importance of the bean as an economic crop
 40 that can be readily grown to maturity to measure product yield, and (4) the
 41 carrot showing good uptake of DIMP from soil in preliminary tests. 42

2.2.2.3 Sampling

Sampling of the growing plants in this series was accomplished by removing entire plants from the soil, rinsing with distilled water to remove any adhering particles or contaminant, followed by dissection into their various parts. These parts were then subjected to appropriate analysis (chemical, gravimetric, or photographic). Tissue samples were taken at various times to assure fresh samples for analysis.

The soil in a selected group of the pots was sampled by means of the coring tool shown in Figure 11. In practice this tool is inserted at right angles to the soil surface and rotated while downward pressure is applied to the handle. After it has penetrated the soil to a depth of 6 in., the tool is lifted out of the soil and the entrapped core deposited in a clean glass sample jar that is immediately capped. The tool is then returned to the same sampling hole and the next 6-in. increment of depth sampled in like manner. The process is repeated for the number of required depth increments.

2.2.2.4 Observations and Measurements

Chemical evaluation analyses were run on the plant leaves during the growing period. On termination of the growing period the plants were harvested and those showing phytotoxicity symptoms were photographed in color to demonstrate differences between control plants and treated plants as to size, root development, coloration. The total quantity of plant material produced was measured by weighing freshly harvested plants.

2.2.2.5 Data Analyses

The data output from this group of soil culture experiments consists of visual evidence of phytotoxicity similar to that described in Section 2.2.1.5. In addition the weights of the various plant parts were determined. These weights and plant histories were subjected to statistical scrutiny preparatory to applying a regression analysis to the weight data. The regression analysis was ultimately considered to be not warranted due to the lack of growth effect shown with the concentrations selected.

5
6
7
8
9
10
11
12
13
14
15
16
17
18
19
20
21
22
23
24
25
26
27
28
29
30
31
32
33
34
35
36
37
38
39
40
41
42
43
44

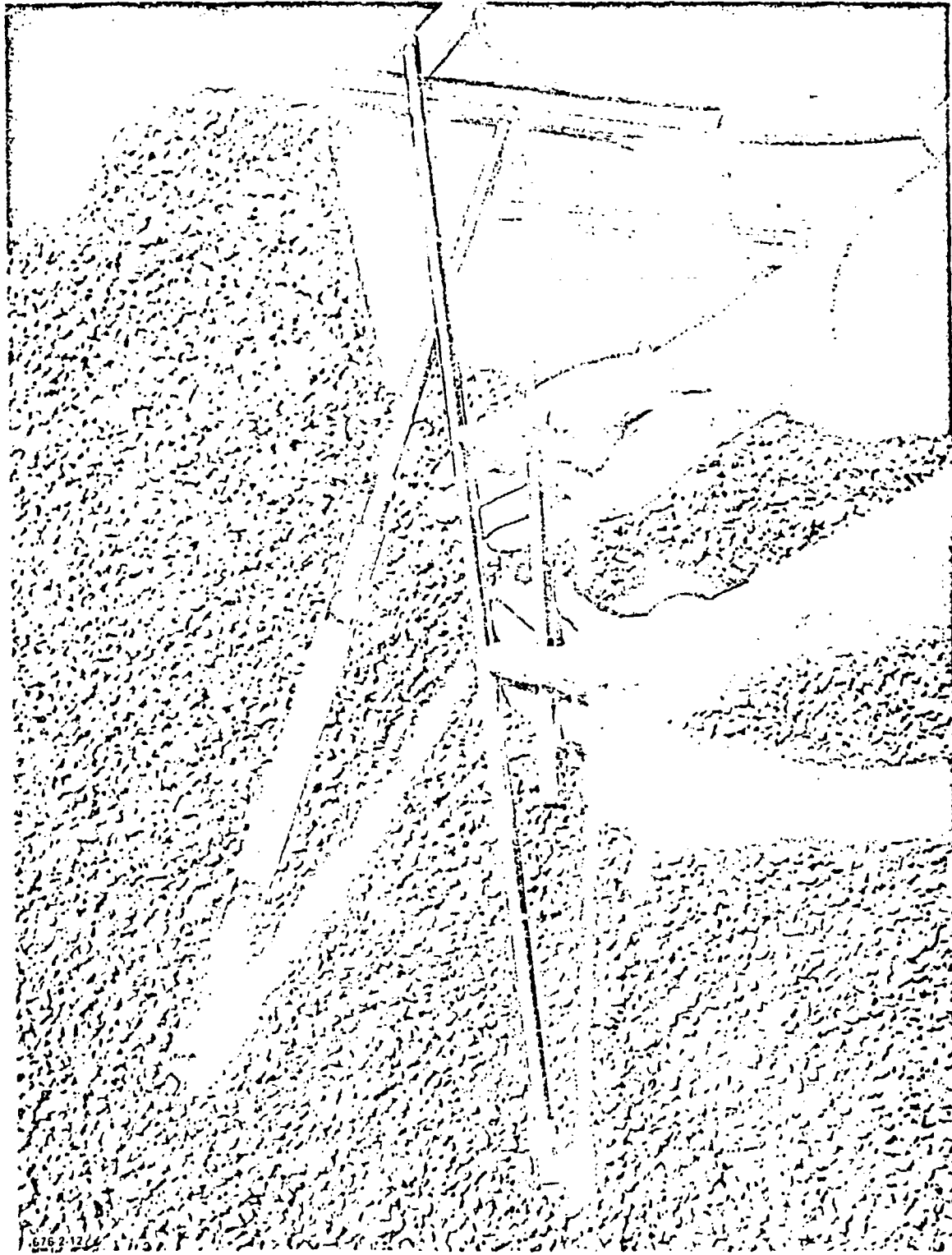

7
8
9
10
11
12
13
14
15
16
17
18
19
20
21
22
23
24
25
26
27
28
29
30
31
32
33
34
35
36
37
38
39
40

Figure 11. Coring Tool.

2.2.3 Bioconcentration Studies

2.2.3.1 Task I

Task I under this phase of the study was designed to determine the existence of the bioconcentration phenomenon in a group of hydroponically grown plants. This is defined in this case as an increase in concentration of a subject chemical in growing plant tissues over the concentration present in the hydroponic nutrient medium. It has been suggested in a previous classified study that phosphorous containing compounds, similar in basic structure to DIMP, have been found concentrated in the leaves of various commercially important plants. A portion of this work was done using radioactive ³²P tracer techniques and the remainder done using extraction and chromatographic procedures similar to those used in this study.

The plants from the hydroponic growth phytotoxicity tests were also harvested and analyzed for contaminant concentration. This was dictated by the relatively small number of plants grown at each concentration level and the relatively long period required for the plants to reach maturity. This dual utilization of plants fitted the broad survey scope of these experiments.

2.2.3.2 Task II

The object of this task was to grow enough select plants in a soil medium (described in Section 2.2.2.1) to permit the production of quantitative data relating to bioconcentration ratios of DIMP and DCPD. The concentrations of 1, 8, and 20 ppm were based chiefly upon visual observation of phytotoxicity symptoms in the hydroponic greenhouse experiments. It was felt that this range would give a definite no-effect level and a definite effect level in the test subjects. The output from this task is a demonstration that compound uptake does occur.

2.2.4 Chemical Analysis

2.2.4.1 General

Because many samples were generated in these types of experiments, it became expedient to devise analyses that permit relatively rapid separation and determination of the compounds of interest. Once the compound is dissolved in an appropriate solvent, gas-liquid chromatography is a convenient way to both separate and quantitate; thus, this was the method used in these evaluations.

Gas-liquid chromatography (GLC), is a technique that involves the physical separation of two or more compounds based on their differential distribution between two phases, one a stationary liquid, the other a moving gas. The moving gas strips the compound of interest (DIMP or DCPD) from the liquid phase separated in time from the solvent and other interfering molecular species and presents it to the chosen detector for quantitation.

A Varian Model 1840 chromatograph (Figure 12) fitted with a flame ionization detector and an alkaline flame phosphorous detector was used in these experiments. The alkaline flame detector is used with DIMP samples because of its selectivity and sensitivity for phosphorus; the flame ionization detector is used for DCPD samples because of their hydrocarbon nature.

Figure 13 is a typical output curve for DIMP. In this case the DIMP concentration is 100 ppb in methanol. The shaded area of the curve is the DIMP response from 170 picograms at the detector.

Generally the sensitivity for phosphorous containing compounds is up to several orders of magnitude greater for the alkaline flame detector than those of a nonphosphorous compound using a flame ionization detector. This difference can be illustrated by comparing Figures 13 and 14.

Determination of the amount of contaminant chemical present in a given solution was made by comparing the area of the compound's chromatographic peak with the peak areas of a series of chromatograms of a standard lot of the same compound. The standard solutions were run so as to bracket both in concentration and in time the test solutions. Several sets of standard solutions were run every day that test solutions were run.

Figure 14 is a chromatogram for DCPD at 100 ppm in chloroform or 60 nanograms of DCPD at the detector. Figure 15 shows how this peak can be improved by concentration of the DCPD solution. Although it makes a reasonable curve the evaporative concentration in this case results in an absolute measurement of approximately one half of the DCPD found in the first, more dilute, case. This loss is assumed to be mostly due to the vaporization of the relatively volatile DCPD. These data point to the necessity of using a solvent for the DCPD analysis which is more easily separated from the DCPD than the common alcohols and halogenated hydrocarbons.

The size of the sample introduced into the chromatograph in most cases consisted of between 0.5 and 1.0 μ l of liquid solution. Reproducing sample volumes smaller than 0.5 μ l routinely became a problem and sample volumes greater than 1 μ l frequently disturb the detector flame characteristics and could lead to nonoptimum sample injections. Analysis of the hydroponic bath

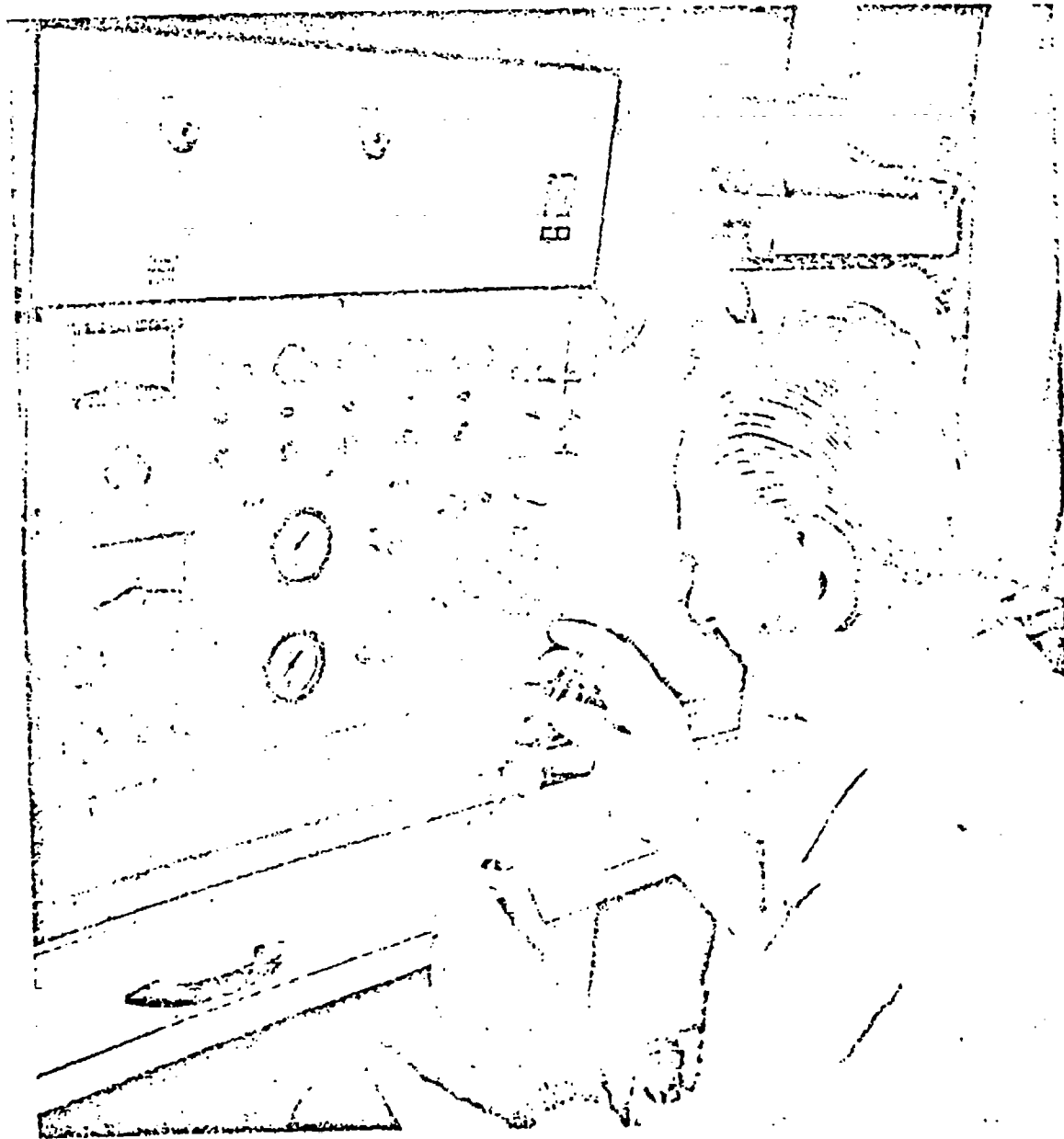

Figure 12. Varian Model 1840-1 Gas-Liquid Chromatograph Used for Trace Analyses.

1
2
3
4
5
6
7
8
9
10
11
12
13
14
15
16
17
18
19
20
21
22
23
24
25
26
27
28
29
30
31
32
33
34
35
36
37
38
39
40
41
42
43
44

1
2
3
4
5
6
7
8
9
10
11
12
13
14
15
16
17
18
19
20
21
22
23
24
25
26
27
28
29
30
31
32
33
34
35
36
37
38
39
40
41
42
43
44

Operator <u>POD</u>	Date <u>10-10-75</u>
Column <u>4'</u>	Detector <u>AELD</u>
Length <u>48"</u>	Voltage
Dia <u>1/8"</u>	Sens. <u>1 x 10⁻¹²</u>
Liquid Phase <u>QF-1</u>	Flow Rate ml/min
Wt. % <u>10</u>	Hydrogen <u>BAR</u> Air <u>AAB</u>
Support GAS: <u>Chrom. Q</u>	Scavenger
Mash <u>60-80</u>	Split
Carrier Gas <u>He</u>	Temperature °C
Room Temp	Det. <u>220</u> Inj. <u>200</u>
Inlet Press. <u>12.5</u> psi	Column Inlet <u>115</u>
Rate	Exit <u>115</u>
CHART SPEED <u>1/25</u> cm/min	Rate
SAMPLE <u>DIMP</u>	Solvent <u>MeOH</u>
Size <u>1.72</u>	Concn. <u>0.1 ppm</u>

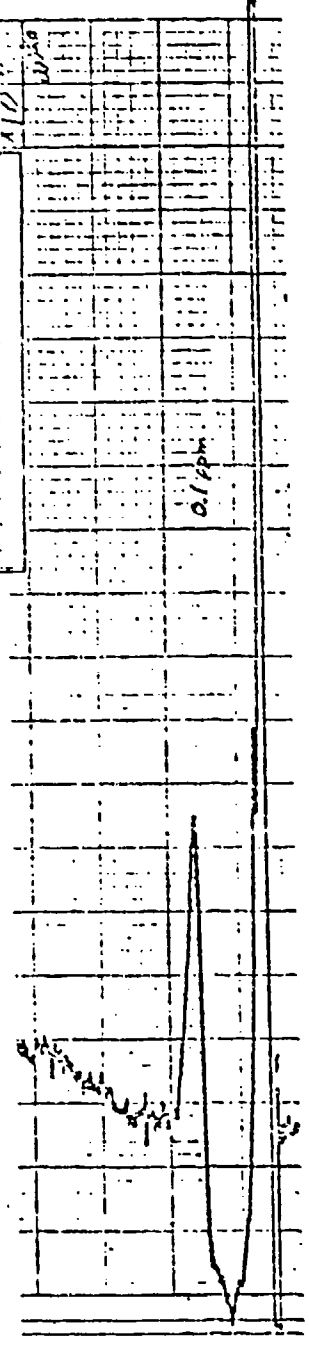

Figure 13. Chromatogram of DIMP in Methanol.

1
2
3
4
5
6
7
8
9
10
11
12
13
14
15
16
17
18
19
20
21
22
23
24
25
26
27
28
29
30
31
32
33
34
35
36
37
38
39
40
41
42
43
44

1
2
3
4
5
6
7
8
9
10
11
12
13
14
15
16
17
18
19
20
21
22
23
24
25
26
27
28
29
30
31
32
33
34
35
36
37
38
39
40
41
42
43
44

Operator <u>POD</u>	Date <u>10-10-75</u>
Column <u>4'</u>	Detector <u>AFID</u>
Length <u>1/8"</u>	Voltage _____
Dia _____	Sensit. <u>1 x 10⁻²</u>
Liquid Phase <u>QF-1</u>	Flow Rate, ml/min _____
Wt. % <u>10</u>	Hydrogen <u>AAB</u> , Air <u>AAB</u>
Support <u>Gas-Chrom-Q</u>	Scavenger _____
Mesh <u>60-80</u>	Split _____
Carrier Gas <u>He</u>	Temperature, °C _____
Rotameter _____	Det. <u>220</u> , Inj. <u>200</u>
Inlet Press. <u>12.5</u> psi	Column Initial <u>115</u>
Rate _____ ml/min	Final <u>115</u>
CHART SPEED <u>1 1/2</u> MIN.	Rate _____
SAMPLE <u>DIMP</u>	Solvent <u>MeOH</u>
Conc. <u>1.77</u>	Concn. <u>0.1 ppm</u>

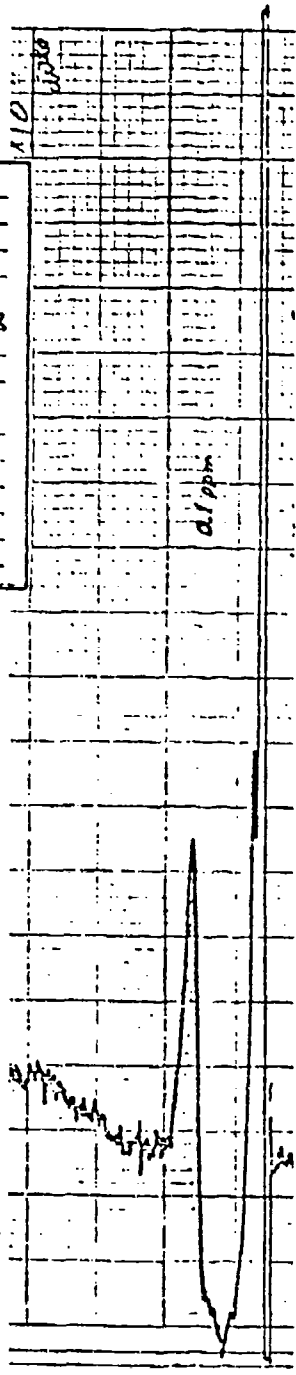
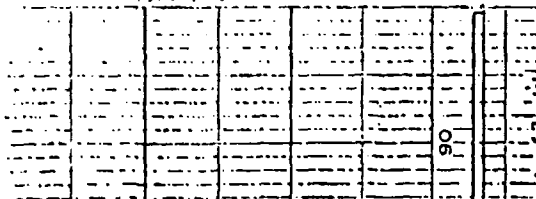

Figure 13. Chromatogram of DIMP in Methanol.

1
2
3
4
5
6
7
8
9
10
11
12
13
14
15
16
17
18
19
20
21
22
23
24
25
26
27
28
29
30
31
32
33
34
35
36
37
38
39
40
41
42
43
44

1
2
3
4
5
6
7
8
9
10
11
12
13
14
15
16
17
18
19
20
21
22
23
24
25
26
27
28
29
30
31
32
33
34
35
36
37
38
39
40
41
42
43
44



Operator	POD	Date	9-19-75
Column	4'	Detector	FID
Length	1/8"	Voltage	
Di.	1/8"	Seals	1x10"
Liquid Phase	QE-1	Flow Rates, ml/min	
Wt. %	10	Hydrogen	25
Support	GBS-CHROM-Q	Air	300
Meth	60-80	Scavenge	
Carrier Gas	11.8	Split	
Rotameter		Temperature, °C	
Inlet Press.	8 psig	Det.	220
Rate		Inj.	200
CHART SPEED	1"=5 min	Column Initial	75
SAMPLE		Final	
Size	0.62	Rate	
		Solvent	CHCl ₃
		Concn.	0.01%

Figure 14. Chromatogram of DCPD in Chloroform, Dilute.

1 water for DCPD was run in essentially the same manner except that the
 2 flame ionization detector was substituted for the alkaline flame ionization
 3 detector. An additional step was added to the DCPD procedure when exper-
 4 imentation showed that it would be chromatographically desirable to have
 5 the DCPD in carbon disulfide so a step is added in the analytical procedure
 6 in which the alcohol extract is partitioned between methanol-water and
 7 carbon disulfide, resulting in a typical sample shown in Figure 16 from
 8 which the lower carbon disulfide layer is chromatographed.

9
 10
 11 2.2.4.2 Water

12
 13 Chemical analysis of the hydroponic baths for determining the quantity of
 14 DIMP present consisted of agitation of the bath with a stream of air as
 15 described in Section 2.2.1.3 followed by sampling an aliquot of the bath with
 16 a sampling pipette. This in turn was followed by injection of an aliquot
 17 (<1.0µl) of the sample directly into the gas-liquid chromatograph fitted with
 18 the alkaline flame ionization detector. The quantity of DIMP indicated by the
 19 chromatogram was calculated through the aliquot factors back to the amount
 20 present in the original sample.

21
 22
 23 2.2.4.3 Soil

24
 25 During the course of the growing period the soil from a select group of pots
 26 was sampled in 6 in. increments with a coring tool (Section 3.2.1.4). These
 27 soil samples were weighed, placed into closed, clean glass jars with mea-
 28 sured volumes of methyl alcohol, agitated on a shaking machine for 15 min
 29 and let stand. When the supernatant liquid over the soil in the jar appeared
 30 clear, an aliquot was removed with a microsyringe and injected directly
 31 into the chromatograph having the proper instrument parameter settings.
 32 Integration of the ensuing chromatograms yielded quantitative data on the
 33 amount of chemical in the soil.

34
 35
 36 2.2.4.4 Plant Tissue

37
 38 The major emphasis in the chemical analysis system was placed on the mea-
 39 surement of contaminant chemical content of the various plant tissues. These
 40 tissues were divided into leaves, stems, roots (fibrous or fleshy), and fruit.
 41 Some relatively minor variations in the analytical procedure were dictated
 42 by the physical state of the sample but basically the same procedure was
 43 followed in each case. This consisted of (1) selection of the tissue to be
 44 analyzed, (2) homogenization of the selected tissue in a suitable solvent.

6
7
8
9
10
11
12
13
14
15
16
17
18
19
20
21
22
23
24
25
26
27
28
29
30
31
32
33
34
35
3
3
3
3

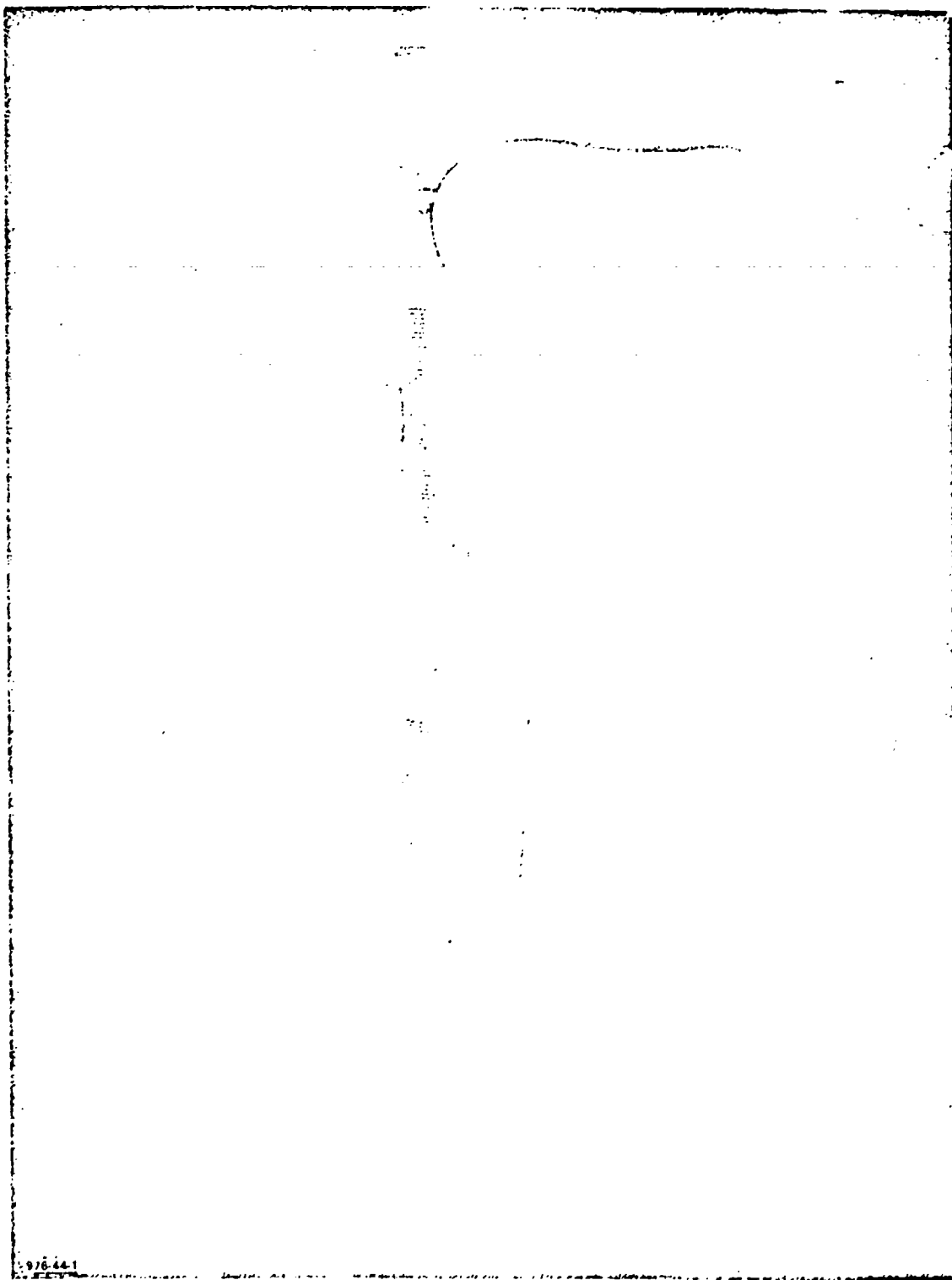

5
6
7
8
9
10
11
12
13
14
15
16
17
18
19
20
21
22
23
24
25
26
27
28
29
30
31
32
33
34
35
36
37
38
39
40
41
42
43
44

Figure 16. DCPD Sample in Carbon Disulfide.

(H₂O, methanol), (3) clarification of the homogenate (settling, centrifuging), (4) dilution with appropriate solvent if necessary, and (5) injection into the chromatograph.

2.3 RESULTS

2.3.1 Phytotoxicity Studies

2.3.1.1 Visual Symptoms of Phytotoxicity

Hydroponics. Data from the original hydroponic series, in the case of DIMP, indicate that there is a variable effect for most plants. Low concentrations showed enhanced growth of some plants and high concentrations resulted in varying degrees of tissue damage. This damage varied from leaf burn to severe necrosis (Figure 17). The phytotoxic effects of the contaminants were observed throughout the growing period.

After 25 days exposure to 1000 ppm DIMP in their nutrient baths all of the plants except the juniper died. Figure 18 shows the comparative effect of 2 weeks exposure of tomatoes to 1000 ppm DIMP in the nutrient bath. Visual examination of the remaining plants after 44 days exposure to DIMP yielded the observations listed in Table 3. These were subjective observations of the growing plants.

After 39 days of exposure to DCPD the following observations were made: In the 1000 ppm DCPD nutrient all remaining plants except the juniper were somewhat stunted. In addition, the corn and rose had browning of the leaves. In the 100 ppm DCPD nutrient the corn and roses also demonstrated chlorosis of the leaves. All plants except the juniper were larger than the control; the juniper was similar to the control. In the 1 ppm DCPD nutrient all plants were similar to the control.

Generally speaking the trend to larger plants in the lower DIMP contamination levels and smaller plants in the higher levels was observed for all plants except the "woody" plant that we used, namely the juniper. During the experiments very little effect was seen on the juniper plant. Figure 19 shows the effect at 2 weeks, 2 months, and 3 months of 1000 ppm DIMP in the juniper nutrient bath. These plants just began to have leaf-tip browning at 2 months

At the conclusion of the experiment, 5 months, the juniper was not essentially different from the condition shown in the bottom photo of Figure 19. The junipers exposed to DCPD at all levels appeared healthy throughout the experiment.

1
2
3
4
5
6
7
8
9
10
11
12
13
14
15
16
17
18
19
20
21
22
23
24
25
26
27
28
29
30
31
32
33
34
35
36
37
38
39
40
41
42
43
44

1
2
3
4
5
6
7
8
9
10
11
12
13
14
15
16
17
18
19
20
21
22
23
24
25
26
27
28
29
30
31
32
33
34
35
36
37
38
39
40
41
42
43
44



CARROT LEAVES - MINOR BURNS

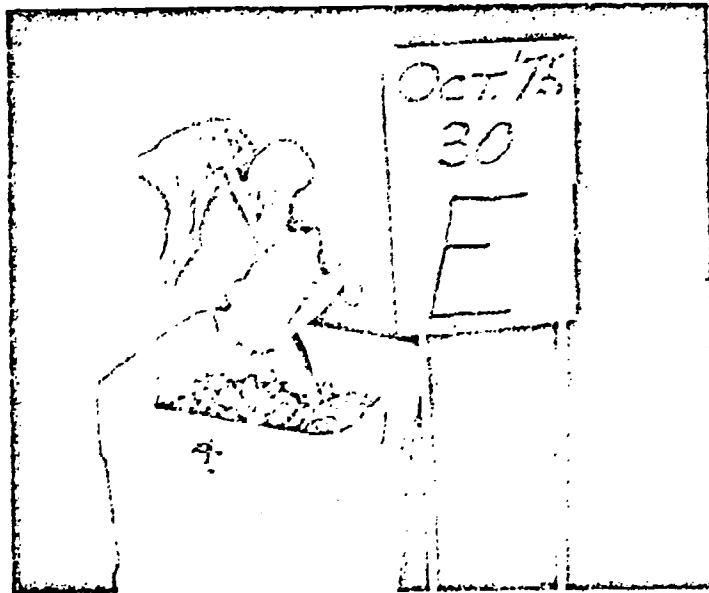

BEAN PLANT - SEVERE NECROSIS

Figure 17. Examples of Variable Effects of DIMP Concentrations on Plant Tissue.

1
2
3
4
5
6
7
8
9
10
11
12
13
14
15
16
17
18
19
20
21
22
23
24
25
26
27
28
29
30
31
32
33
34
35
36
37
38
39
40
41
42
43
44

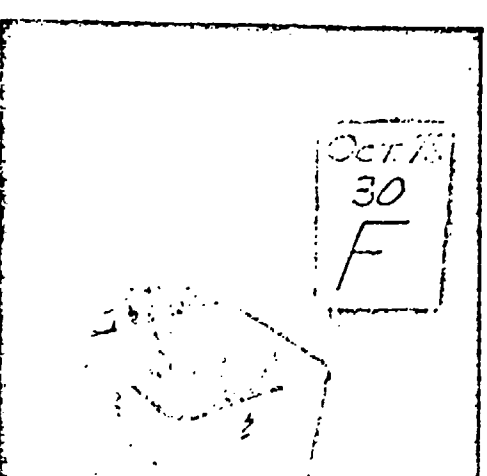
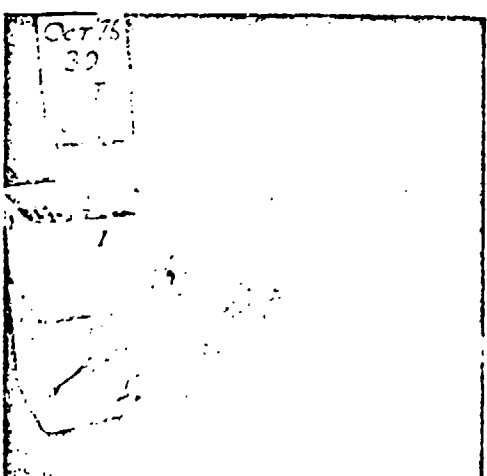
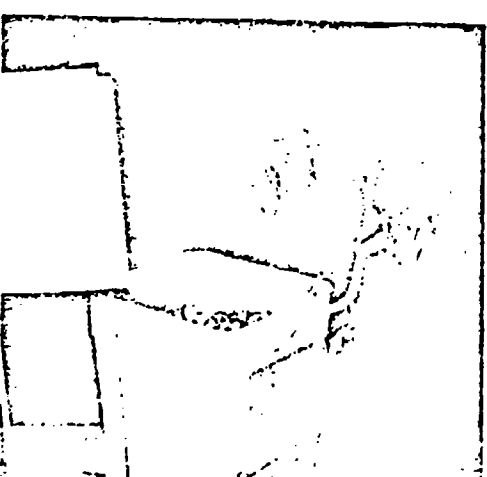
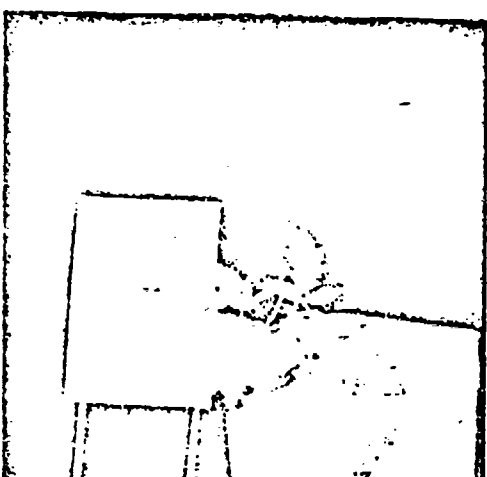
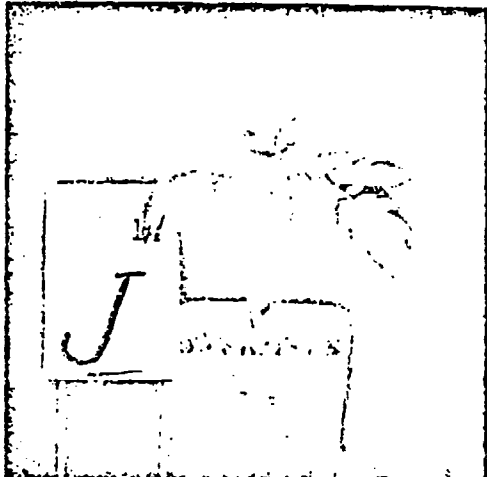

1
2
3
4
5
6
7
8
9
10
11
12
13
14
15
16
17
18
19
20
21
22
23
24
25
26
27
28
29
30
31
32
33
34
35
36
37
38
39
40
41
42
43
44

Figure 18. Comparison of Tomato Plants: Not Exposed to DIMP Nutrient Bath (L); Exposed to DIMP Nutrient Bath (R).

Table 3. Plant Appearance After 44 Days.
Exposure to DIMP.

Plant	Concentration (ppm)	State
Tomato	100	Advanced necrosis
Corn	100	Larger than control, healthy
Bean	100	Stunted with some necrosis
Fescue	100	Stunted
Sugar beet	100	Stunted
Carrot	100	Healthy
Rose	100	Extreme necrosis
Wheat	100	Larger than control, limited leaf burn
Juniper	100	Healthy
Tomato	10	Larger than control, healthy
Corn	10	Larger than control, healthy
Bean	10	Healthy, individual plants larger than control
Fescue	10	Healthy
Sugar beet	10	Larger than control, some leaf burn
Carrot	10	Larger than control
Rose	10	Leaf chlorosis
Wheat	10	Larger than control
Juniper	10	Healthy
All plants except juniper	1	Slightly larger than control, healthy
Juniper	1	Healthy

3
4
5
6
7
8
9
10
11
12
13
14
15
16
17
18
19
20
21
22
23
24
25
26
27
28
29
30
31
32
33
34
35
36
37
38
39
40
41
42
43
44

1
2
3
4
5
6
7
8
9
10
11
12
13
14
15
16
17
18
19
20
21
22
23
24
25
26
27
28
29
30
31
32
33
34
35
36
37
38
39
40
41
42
43
44

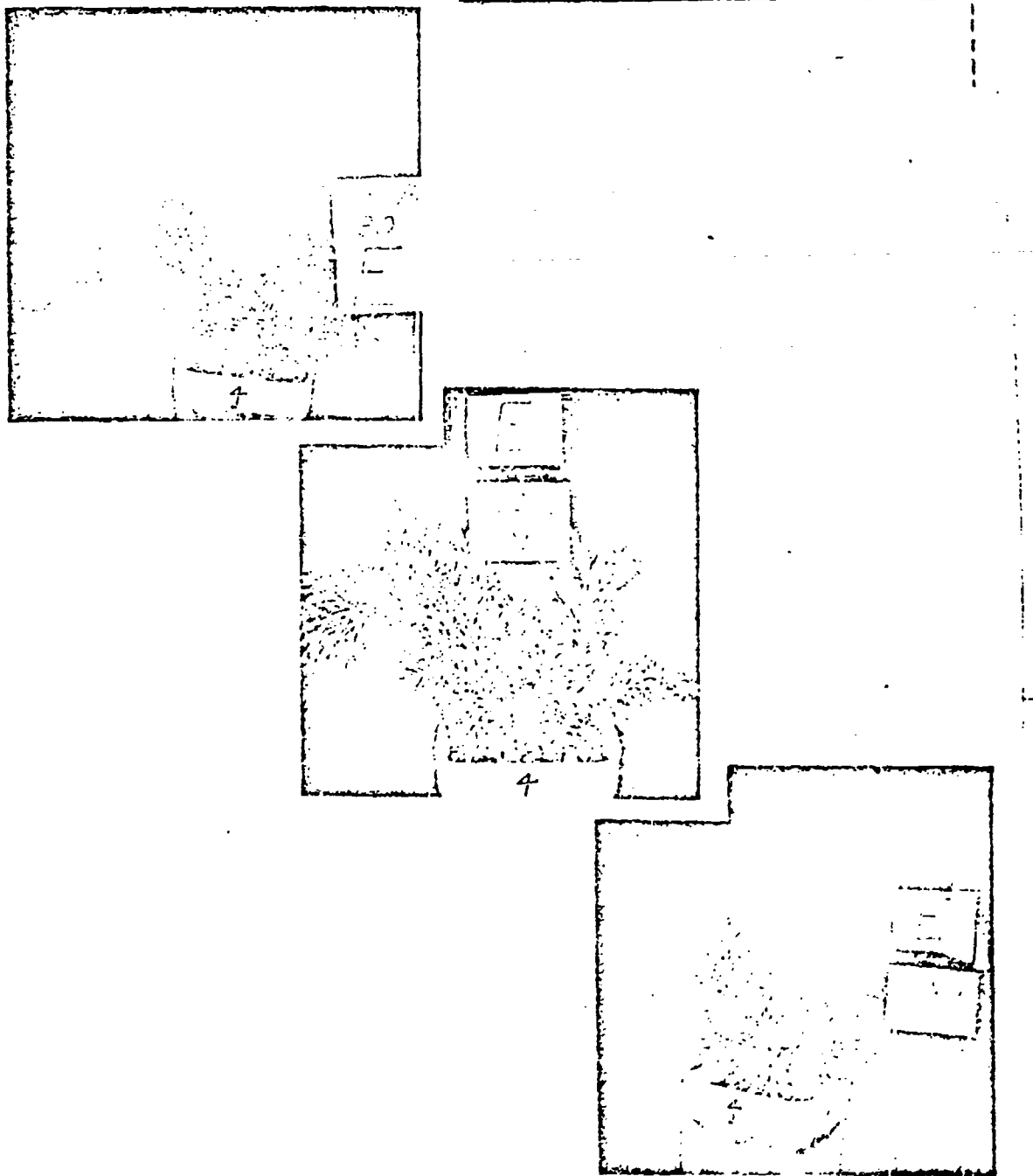

Figure 19. Effects of DIMP on Juniper Plant.

Figures 20 and 21 are examples of the effect of different contaminants. The former is a 1000 ppm DIMP exposure for 2 weeks of a corn seedling. The latter is a corn plant started on the same day as the previous one and exposed to 1000 ppm DCPD for 2 months. The first (DIMP) plant died shortly after this photograph was taken; the second (DCPD) plant survived the experiment but never achieved much more growth than shown here. It did, however, produce one malformed ear of corn. No relationship was determined between the malformed ear and the presence of DCPD.

In general the phytotoxicity of these compounds was demonstrated in two ways: In the case of DIMP the outstanding symptom was the leaf necrosis or burned appearance of the leaf as in the case of the corn in Figure 20. The DCPD on the other hand rarely showed this effect, but instead evidenced a stunting of growth at a given contaminant level. The DCPD plants appeared to have the ability to adapt to the presence of the chemical and ultimately produced what appeared to be reasonably healthy looking plants even in a condition of chronic exposure, except in extreme cases. The plants in the DIMP exposure did not seem to have this recuperative ability.

Soils. The second phase of the plant investigations was concerned with using the successful techniques of analysis from the hydroponic study and applying them to the case of plants growing in soil culture. In these tests we grew greater numbers of fewer species of plants. Specifically these are alfalfa, sugar beet, bean, carrot, and wheat.

In a series containing 150 plants of each species actively exposed to each of DIMP or DCPD, in irrigation water in sandy loam, the plants showed no significant visible symptoms of phytotoxicity that can be ascribed to the 1, 8, or 20 ppm of contaminant.

An example of these plants is shown in Figure 22. These sugar beets were grown from seed; the active plant on the right was irrigated with distilled water containing 20 ppm DIMP starting 12 days after planting and 6 days after the shoots appeared. The plants on the left of the picture are negative controls, the center is positive control, and on the right the active or treated plant. The equivalent DCPD plants are shown in Figure 23.

A third condition was also investigated: planting the seeds in soil that had been contaminated before seeding. A number of seeds of the same five plants were sown in contaminated soil and irrigated with distilled water containing 0, 50, 100, 300, 500, 700, and 1000 ppm DIMP or DCPD. The early condition of these plants indicated that even the highest concentration did not prohibit germination but as the plants aged, around 1 week to 10 days, the effects of the agent were seen. In the case of DIMP there was leaf curl and browning

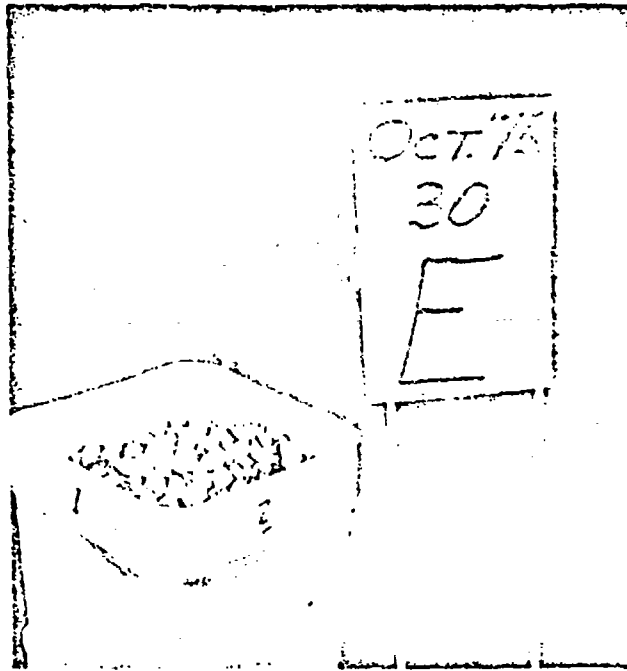

Figure 20. Effects of DIMP on Corn Seedling After 2 Weeks.

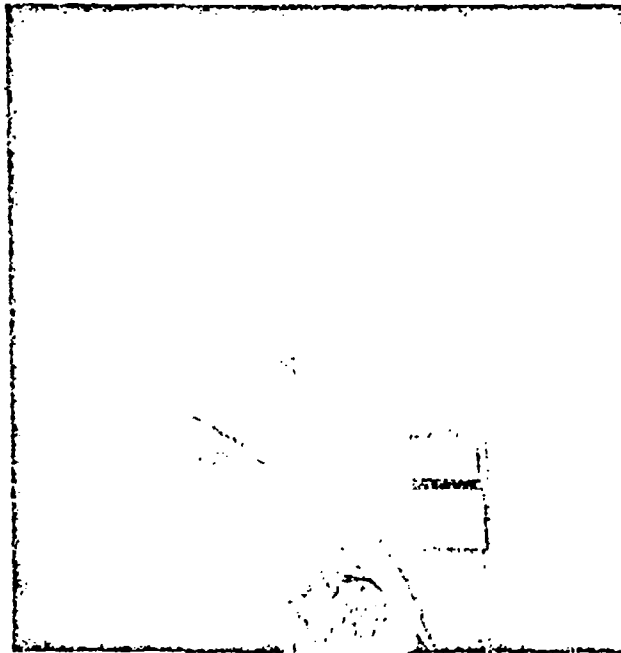
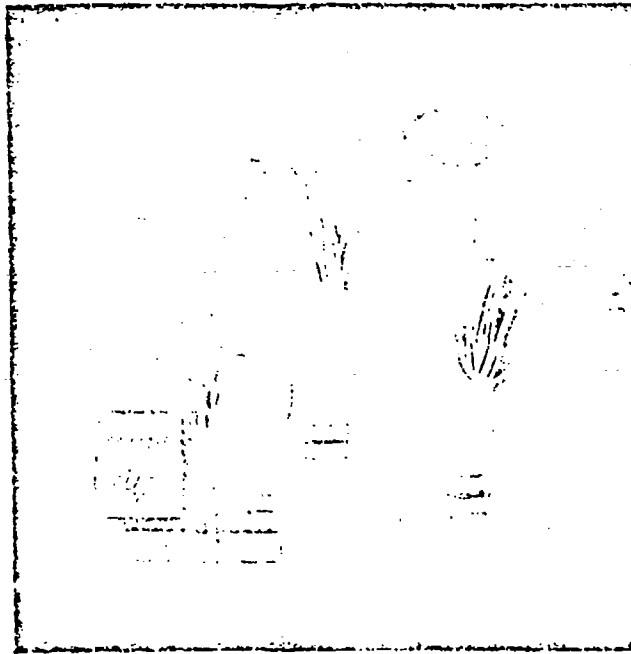

Figure 21. Effects of DCPD on Corn Seedling After 2 Months.

1
2
3
4
5
6
7
8
9
10
11
12
13
14
15
16
17
18
19
20
21
22



1
2
3
4
5
6
7
8
9
10
11
12
13
14
15
16
17
18
19
20
21

Figure 22. Effects of DIMP on Sugar Beets.

23
24
25
26
27
28
29
30
31
32
33
34
35
36
37
38
39
40
41
42
43
44

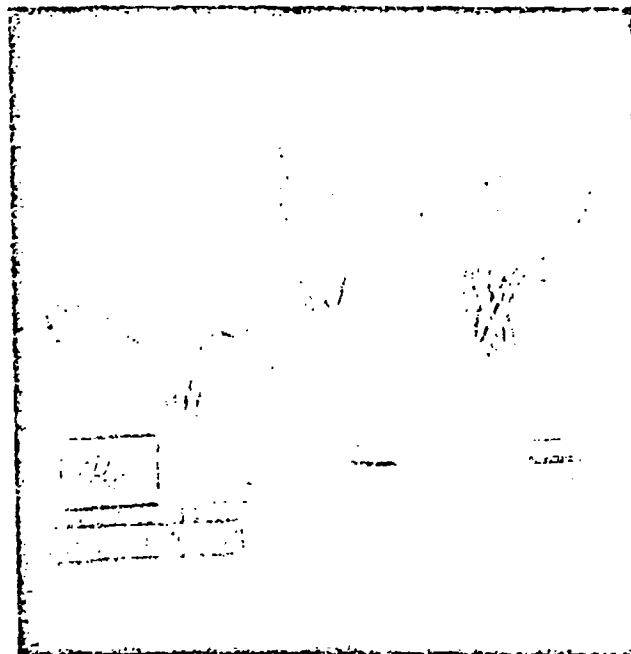

22
23
24
25
26
27
28
29
30
31
32
33
34
35
36
37
38
39
40
41
42
43
44

Figure 23. Effects of DCPD on Sugar Beets.

from approximately the 100 ppm group and up. The photographs in Figure 24 show the relatively healthy plants in the 50 ppm DIMP exposure, those with minimal symptoms in the 100 ppm case, and the definitely damaged plants at 300 ppm after 33 days exposure. The center pot in each case is the control and the side pots are replicate active ones. The effective concentration level appears to be lower as the age of the plant increases. The 700 and 1000 ppm plants were stunted and showed leaf curl at 2 to 3 weeks. Those below that concentration appeared to be very similar to the controls. At 33 days it would be difficult to ascribe any phytotoxicity to the DCPD at any level. To that time 5.5 liters of irrigation solution had been added to each pot. There is no browning evidenced in the DCPD plants. In the first week after breaking the surface most of the DCPD plants appeared healthy. Figure 25 shows a portion of the greenhouse where these experiments were conducted shortly before harvesting. The concentrations were arranged so that the highest level was at the north end in alternate rows and at the south end in the intervening rows.

At harvest time essentially the same conditions of health existed in the plants as at 33 days, except that all of the plants were beginning to show minimal signs of leaf burning at the low concentration of 50 ppm DIMP.

2.3.1.2 Measurements of Phytotoxicity

The determination of total mass of the growing plant is another means of evaluating phytotoxicity, the general assumption being that the toxic condition results in a smaller mass. A series of determinations on the radish plants harvested at the same age demonstrates this concept. The results are given in Table 4 and Figures 26 and 27.

The greater the amount of DCPD added to the radish nutrient bath, the less biomass is recovered. This is not true in the case of DIMP where 1 and 10 ppm result in larger plants while greater concentrations result in much smaller plants. The same type of information for mature tomato plants is given in Table 5. The DIMP and DCPD experiments were conducted in different rooms, which may account for differences in control weight.

The plants shown previously in Figure 22 from the soil culture tests show a difference in total mass with DIMP contamination.

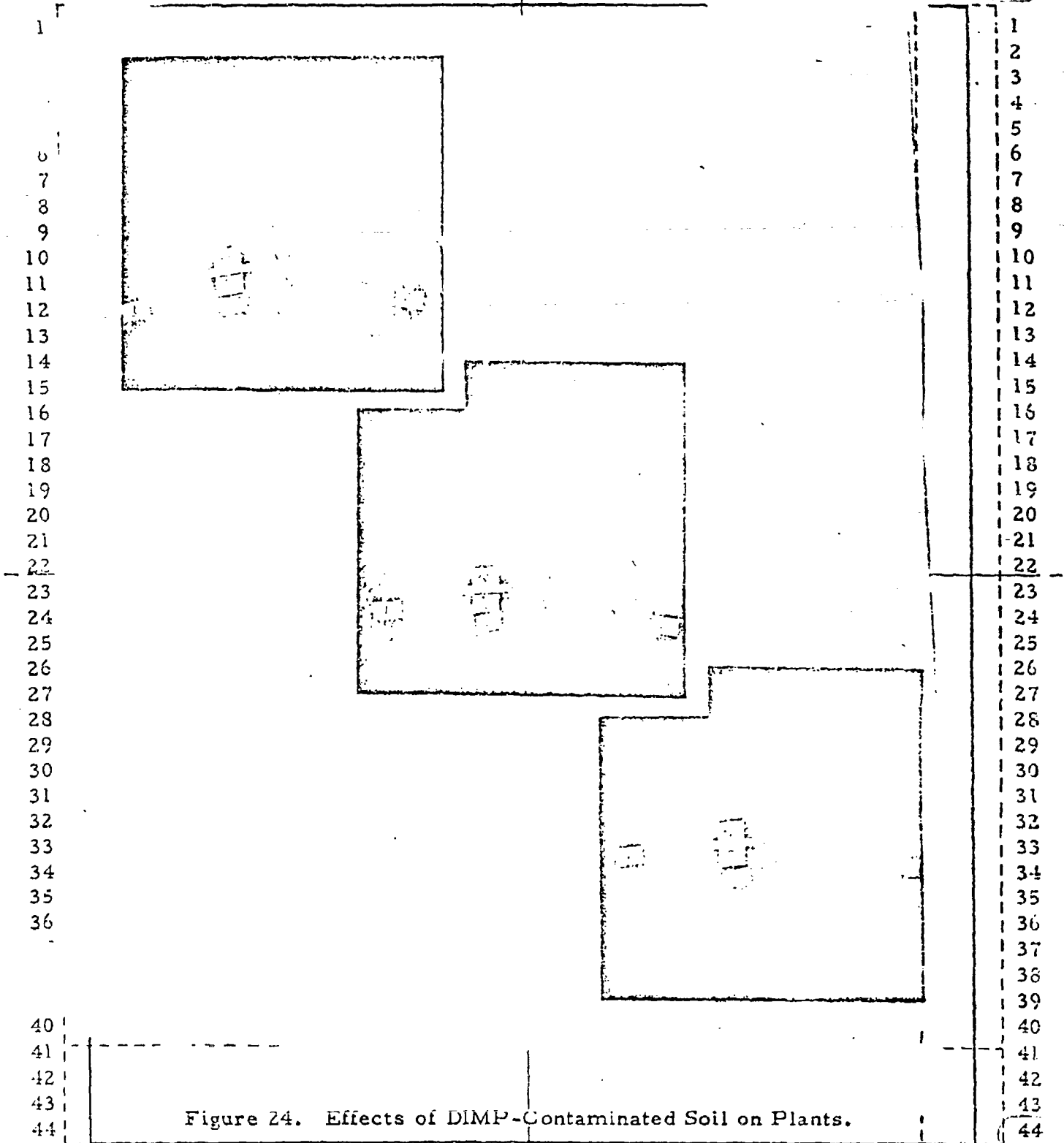

1
2
3
4
5
6
7
8
9
10
11
12
13
14
15
16
17
18
19
20
21
22
23
24
25
26
27
28
29
30
31
32
33
34
35
36
37
38
39
40
41
42
43
44

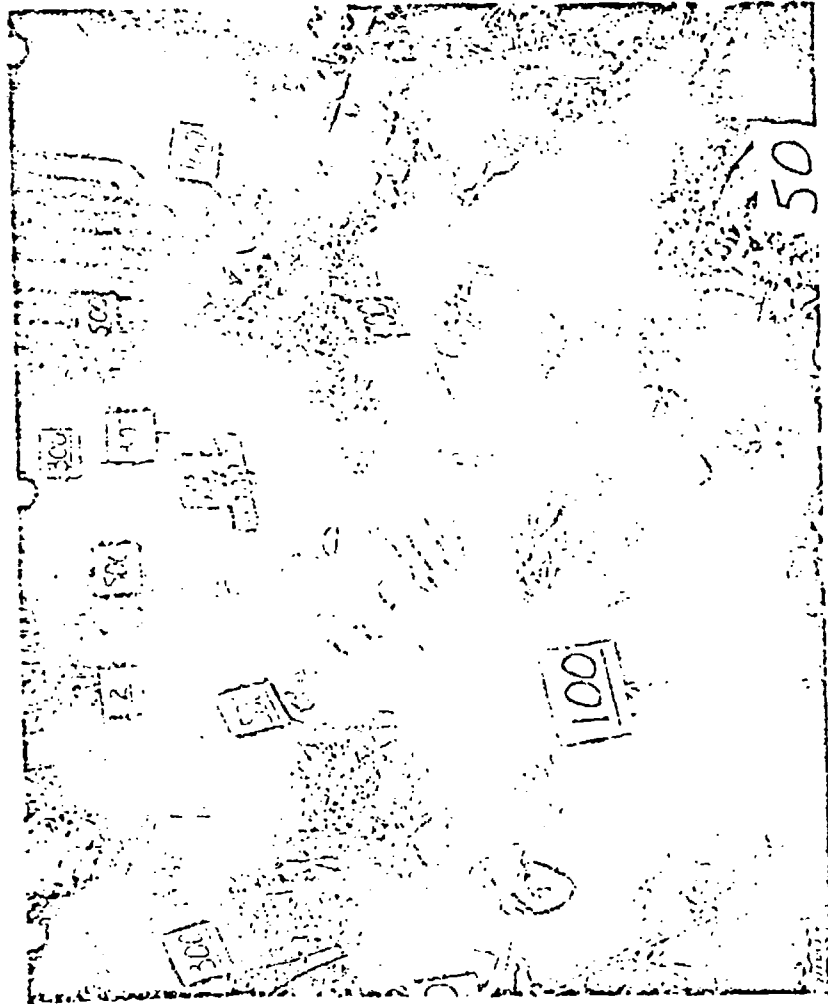

Figure 25. Portion of Greenhouse Plants in
0-1000 ppm Range Finding Experiments.

1
2
3
4
5
6
7
8
9
10
11
12
13
14
15
16
17
18
19
20
21
22
23
24
25
26
27
28
29
30
31
32
33
34
35
36
37
38
39
40
41
42
43
44

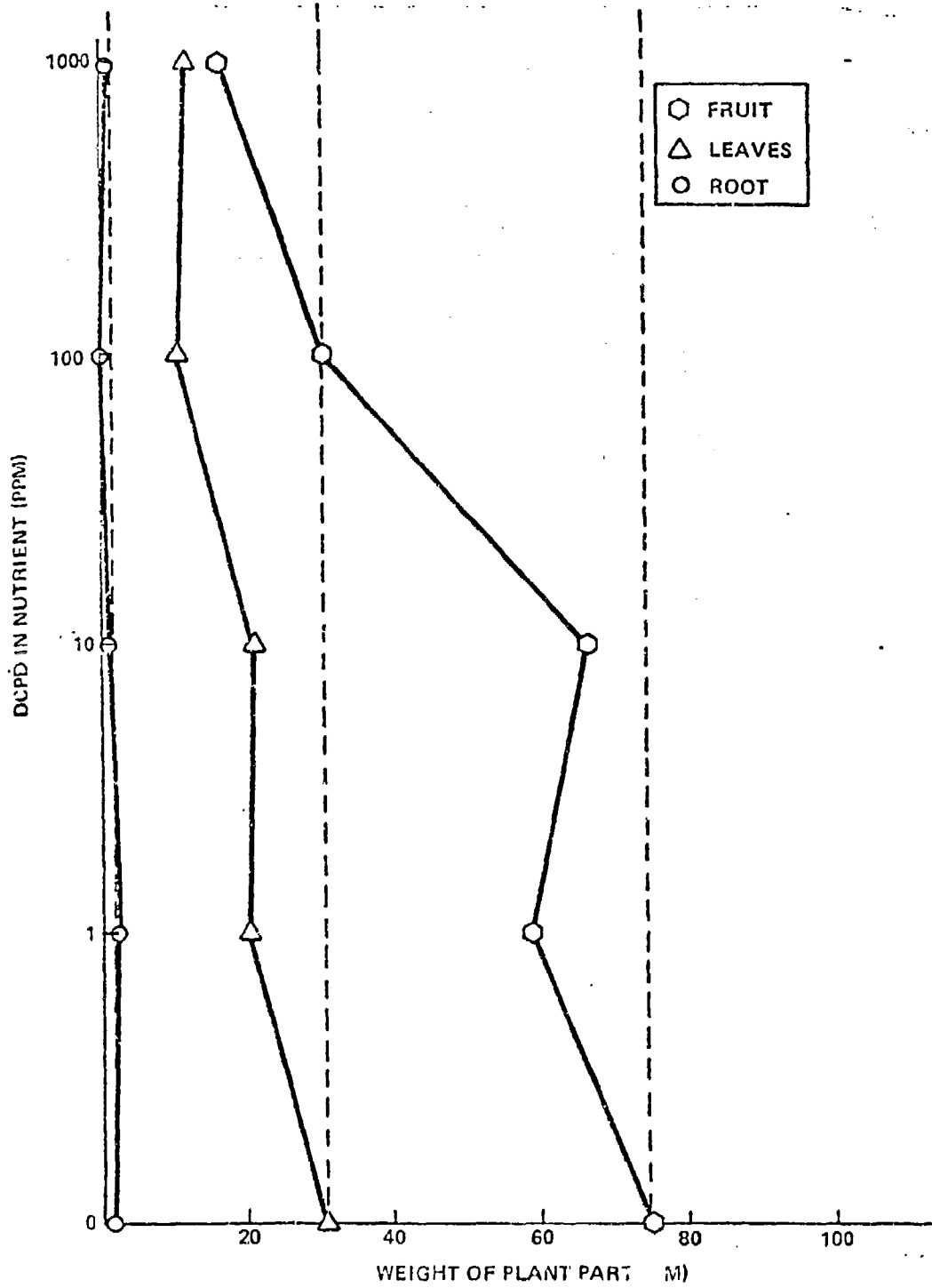

Figure 26. Yield of Radish Plants from Various Levels of DCPD Contamination.

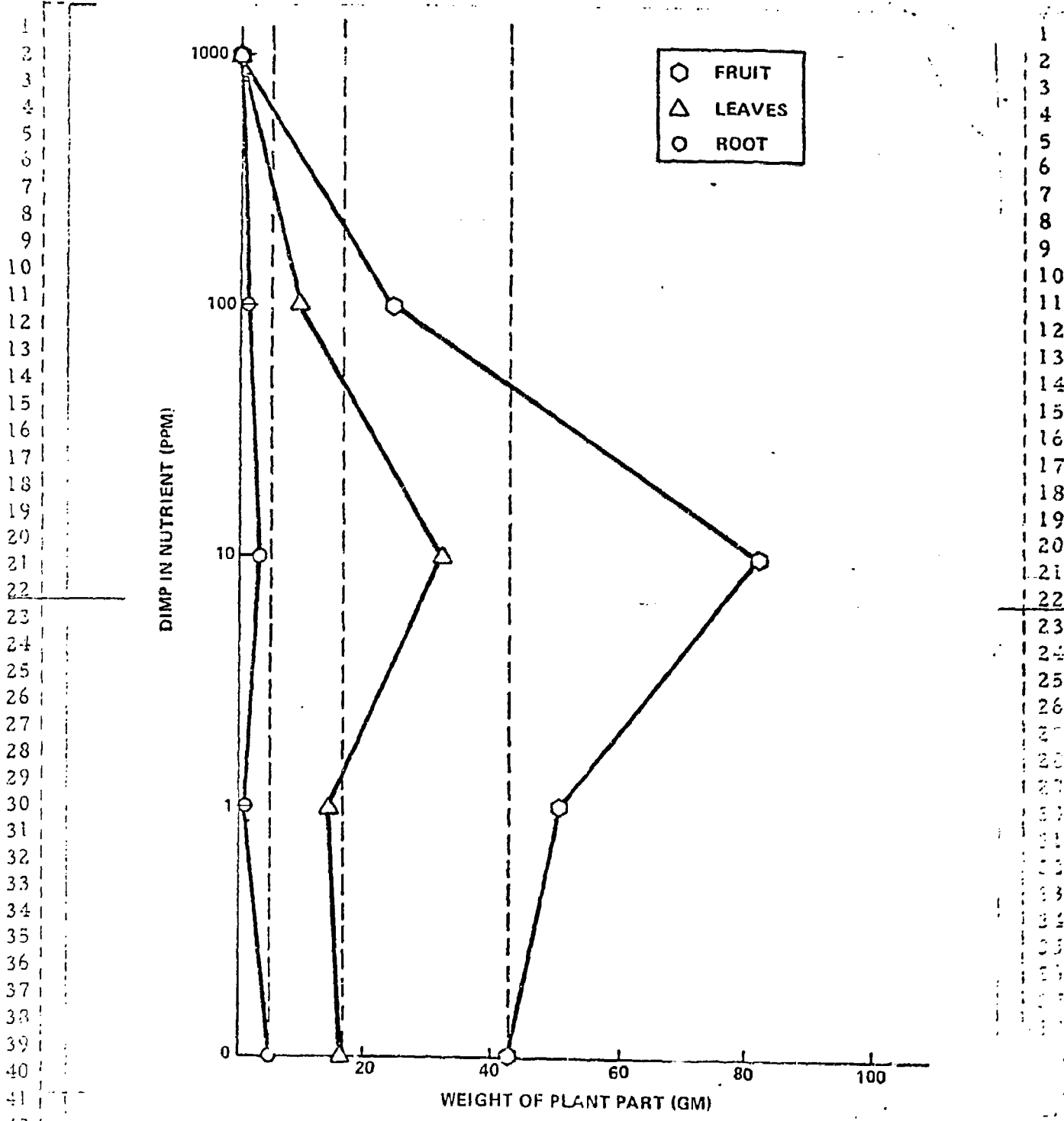

Figure 27. Yield of Radish Plants from Various Nutrient Levels of DIMP Contamination.

Table 4. Yield of Radish Plants from Various Nutrient Levels of Contamination.

Type and Level of Contamination	Weight of Plant Part (gm)			Total Plant Weight (gm)
	Fibrous Root	Fleshy Root	Leaves	
DIMP Control (ppm)	5.2	43.1	16.7	65.0
1.0	0.8	51.2	14.4	66.4
10.0	3.2	82.2	32.8	118.2
100.0	1.7	24.3	9.9	35.9
1000.0	0.05	0.13	0.29	0.5
DCPD Control (ppm)	2.0	74.6	30.8	107.4
1.0	2.3	58.8	20.5	81.6
10.0	1.2	66.4	21.2	88.8
100.0	0.6	30.7	11.0	42.3
1000.0	1.2	17.6	12.5	31.3

Table 5. Yield of Tomato Plants From Various Nutrient Levels of Contamination--150 Days.

Contamination Level (ppm)	Total Plant Weight (gm)	
	With DIMP	With DCPD
Control	6254	8122
1.0	3590	2757
10.0	9202	8246
100.0	4610	7606
1000.0	2	1045

The weights of the three plants from left to right are 39.5, 66.7, and 48.6 gm respectively. The active plant container at the time this photograph was taken had received 15 liters of 20 ppm irrigation water containing a total of 300 mg of DLMP spread out over 64 days. Superficially one might assume that the trend seen in the hydroponic data is being followed, that is, a small amount of DLMP enhancing the growth. The mass of subparts of these three plants is: leaves -- 14, 15, and 17 gm from left to right; stems -- 5.9, 20.0, and 12.0 gm; and root -- 19.0, 19.8, and 31.2 gm respectively. Here again the economic portion of the plant is about 35% larger in the contaminated case.

A somewhat different ratio of masses is seen in the DCPD plants shown in Figure 23. The plant on the left is the same negative control as in Figure 22: the positive control weighs 48.3 gm total, and the two active plants on the right weigh 28.5 and 29.3 gm respectively. The comparison of root sizes is possibly more significant since negative control is 19.0 gm, positive control is 20.4 gm, and the active plants 9.1 and 9.6 gm respectively. The trend to stunting indicated in this single sampling of beets does not continue in the mature plants. A limited amount of statistical manipulation has been done on the ultimate mature yield data from these experiments. These data are summarized in Table 6 and Figures 28 and 29. Data from individual plant parts are given in Appendix A, Table A-1.

Table 6 presents the yield of harvestable portion of various plants as a function of the concentration of contaminants. The average of the yield of the three positive control plants was used as the zero concentration yield. Also in Table 6 is the average yield at each concentration as a percentage of the maximum average.

With five plant types and two contaminants there are ten situations to evaluate. In four of these situations the maximum average yield occurred with zero contaminant. In the other six cases the maximum yield was obtained at some higher concentrations. Figures 28 and 29 illustrate the situation.

After harvesting, the plants from the soil range finding experiment were fractionated into their major parts and weighed.

Data on the biomass of the sugar beet, alfalfa, carrot, and bean are given in Table 7. Plotting the mass data for the normally edible portion of the plants gives the graphs shown in Figures 30 through 33.

1
2
3
4
5
6
7
8
9
10
11
12
13
14
15
16
17
18
19
20
21
22
23
24
25
26
27
28
29
30
31
32
33
34
35
36
37
38
39
40
41
42
43
44

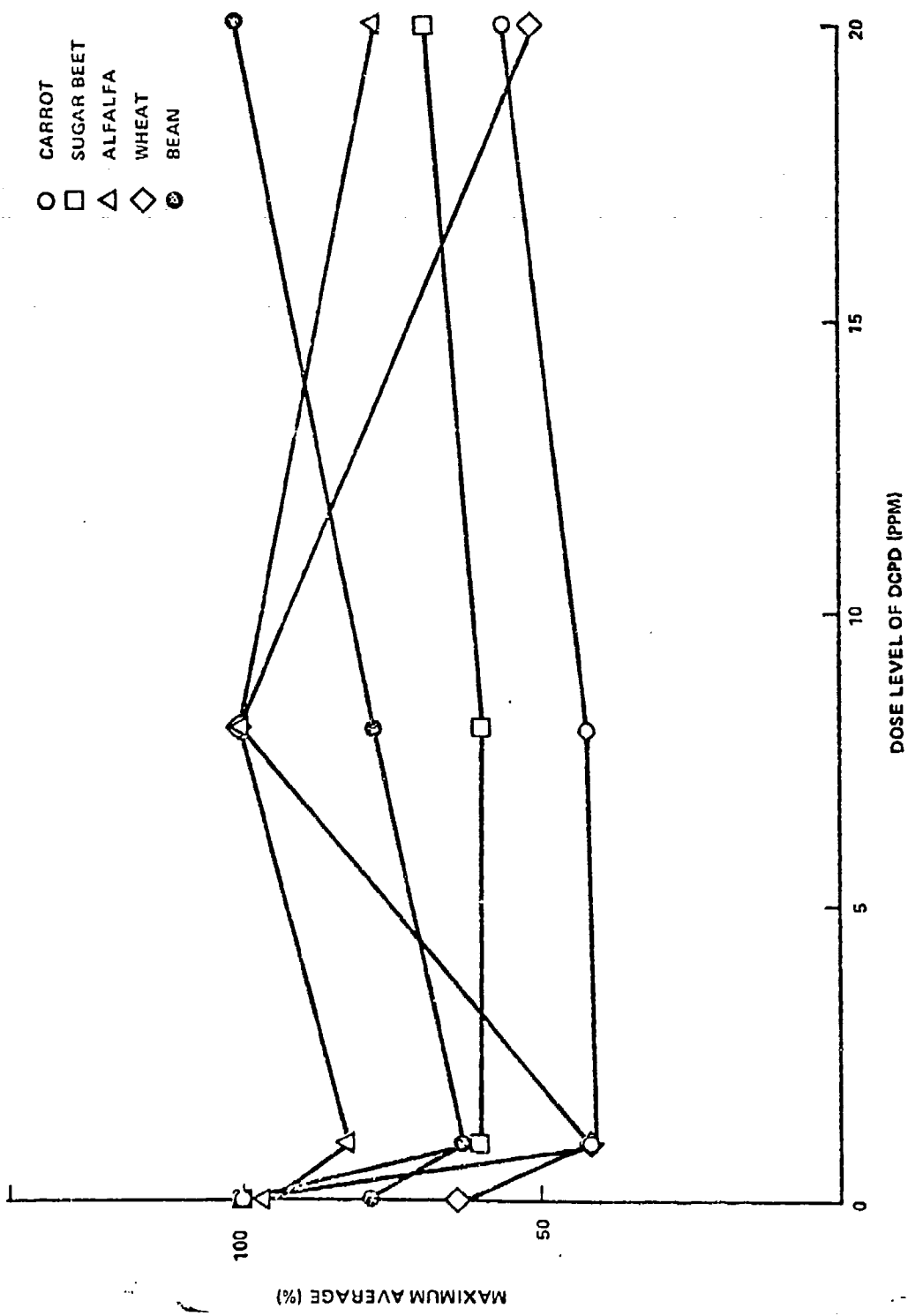

Figure 28. Effect of Dose Level of DCPD on Yield of Various Plants.

1
2
3
4
5
6
7
8
9
10
11
12
13
14
15
16
17
18
19
20
21
22
23
24
25
26
27
28
29
30
31
32
33
34
35
36
37
38
39
40
41
42
43
44

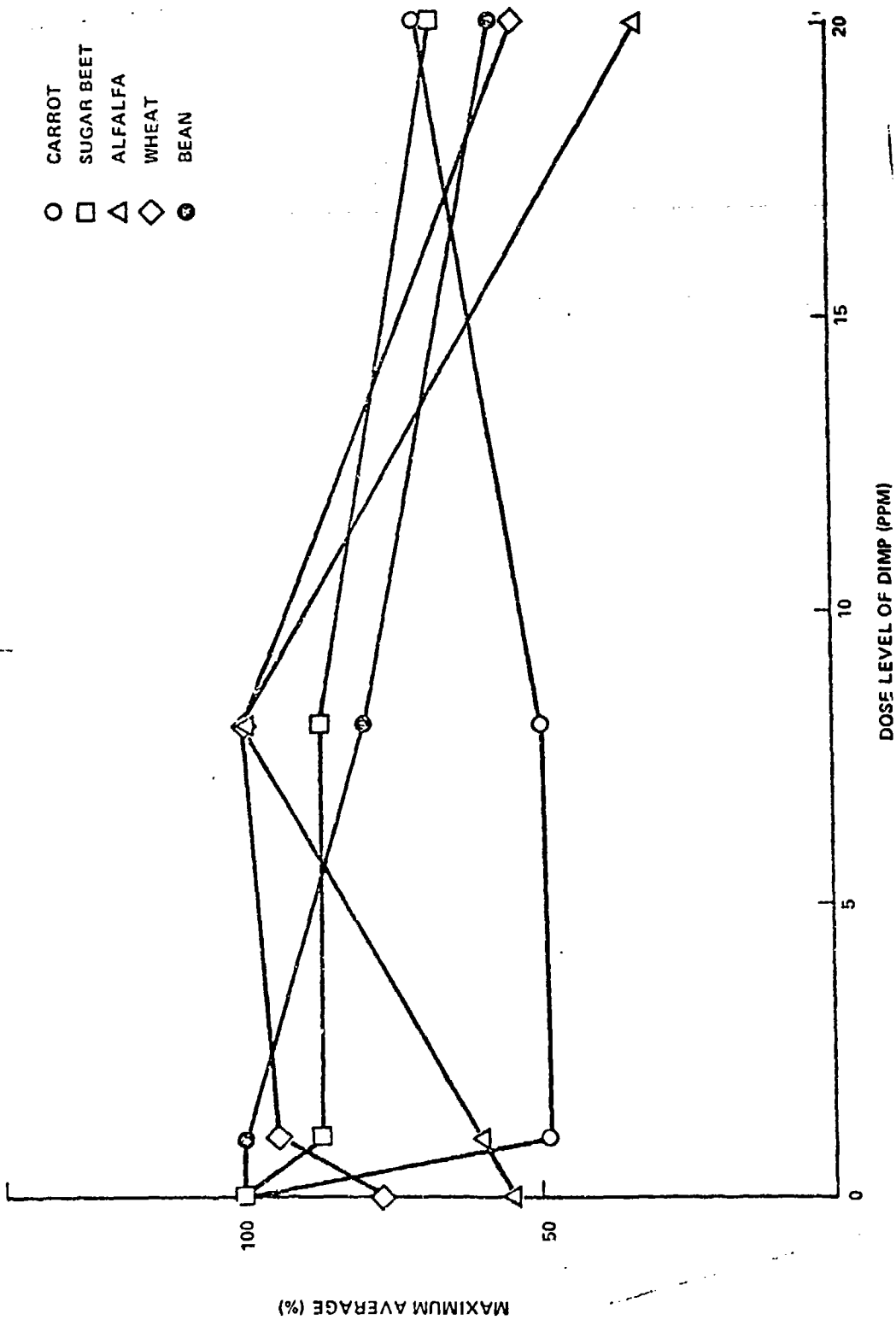

Figure 29. Effect of Dose Level of DIMP on Yield of Various Plants.

Table 6. Yield of Harvestable Portion of Plants.

Plant Type	Contaminant	ppm	Average Weight (gm)	% of Max Average
Carrot	DIMP	0	119.21	100.00
		1	57.9	48.57
		8	58.6	49.16
		20	83.4	69.96
	DCPD	0	246.73	100.00
		1	101.0	40.94
		8	102.9	41.71
		20	137.8	55.85
Beet	DIMP	0	45.45	100.00
		1	39.8	87.57
		8	39.6	87.13
		20	30.5	67.11
	DCPD	0	74.3	100.00
		1	44.7	60.16
		8	44.5	59.89
		20	50.7	68.24
Alfalfa	DIMP	0	3.90	54.93
		1	4.19	59.01
		8	7.10	100.00
		20	2.32	32.58
	DCPD	0	3.70	96.61
		1	3.16	82.51
		8	3.83	100.00
		20	2.97	77.55
Wheat	DIMP	0	2.22	77.08
		1	2.73	94.79
		8	2.88	100.00
		20	1.53	53.13
	DCPD	0	1.76	64.00
		1	1.15	41.82
		8	2.75	100.00
		20	1.39	50.55
Bean	DIMP	0	12.09	100.00
		1	12.06	99.75
		8	9.62	79.57
		20	6.85	56.66
	DCPD	0	10.34	78.39
		1	8.24	62.47
		8	10.28	77.94
		20	13.19	100.00

Table 7. Average Weight of Plant Parts in Soil Culture at 201 Days. (Sheet 1 of 4)

Leaf	Average Weight (gm)				Number of Plants in Average	Contam- inant Type	Concentration of Contam- inant in H ₂ O (ppm)
	Stem	Root	Edible Root/ Plant	Total Plant			
SUGAR BEET							
166.93	-	-	187.35	354.28	4	DIMP	Control
16.68	-	-	12.00	28.68	5	DIMP	50
34.08	-	-	29.50	63.58	4	DIMP	100
20.74	-	-	6.38	27.12	5	DIMP	300
1.05	-	-	1.51	2.56	1	DIMP	500
94.30	-	-	46.60	140.90	5	DCPD	Control
115.13	-	-	112.38	227.51	4	DCPD	50
163.07	-	-	146.37	309.44	3	DCPD	100
151.93	-	-	188.37	350.30	3	DCPD	300
102.43	-	-	78.25	180.68	4	DCPD	500
85.45	-	-	91.50	176.95	2	DCPD	700
133.05	-	-	135.7	268.75	2	DCPD	1000

1
2
3
4
5
6
7
8
9
10
11
12
13
14
15
16
17
18
19
20
21
22
23
24
25
26
27
28
29
30
31
32
33
34
35
36
37
38
39
40
41
42
43
44

Table 7. Average Weight of Plant Parts in Soil Culture at 20 Days. (Sheet 2 of 4)

Average Weight (gm)					Number of Plants in Average	Contaminant Type	Concentration of Contaminant in H ₂ O (ppm)
Leaf	Stem	Root	Edible Root/Plant	Total Plant			
ALFALFA							
4.89	8.68	4.25	-	17.82	15	DIMP	Control
2.72	5.19	2.24	-	10.15	14	DIMP	50
0.92	4.20	1.19	-	6.31	11	DIMP	100
0.60	1.03	0.12	-	1.75	3	DIMP	300
1.48	3.39	0.22	-	5.09	2	DIMP	500
4.20	4.74	3.24	-	12.18	12	DCPD	Control
6.35	10.58	4.45	-	21.38	12	DCPD	50
8.84	12.44	6.04	-	27.32	7	DCPD	100
4.94	9.72	3.92	-	18.58	5	DCPD	300
6.36	14.09	4.37	-	24.82	2	DCPD	500 ^a

1
2
3
4
5
6
7
8
9
10
11
12
13
14
15
16
17
18
19
20
21
22
23
24
25
26
27
28
29
30
31
32
33
34
35
36
37
38
39
40
41
42
43
44

Table 7. Average Weight of Plant Parts in Soil Culture at 201 Days. (Sheet 3 of 4)

Average Weight (gm)				Number of Plants in Average	Contam- inant Type	Concentration of Contam- inant in H ₂ O (ppm)
Leaf	Stem	Root	Edible Root/ Plant			
CARROT						
1.29	1.54	-	17.01	19.84	DIMP	Control
0.75	1.33	-	19.65	21.73	DIMP	50
0.17	0.50	-	0.05	0.72	DIMP	300
2.15	0.84	-	0.40	3.39	DIMP	500
2.49	3.18	-	17.49	23.16	DCPD	Control
7.80	11.40	-	39.40	58.60	DCPD	100
5.37	10.03	-	50.57	65.97	DCPD	300
3.87	9.58	-	63.23	76.68	DCPD	500
4.30	7.35	-	36.65	48.30	DCPD	700
4.42	6.40	-	50.70	61.52	DCPD	1000

1
2
3
4
5
6
7
8
9
10
11
12
13
14
15
16
17
18
19
20
21
22
23
24
25
26
27
28
29
30
31
32
33
34
35
36
37
38
39
40
41
42
43
44

Table 7. Average Weight of Plant Parts in Soil Culture at 201 Days. (Sheet 4 of 4)

Leaf	Average Weight (gm)				Number of Plants in Average	Contaminant Type	Concentration of Contaminant in H ₂ O (ppm)
	Stem	Root	Edible Fruit Plant	Total Plant			
BEAN							
2.13	9.83	1.17	9.67	22.80	3	DIMP	Control
3.00	34.50	7.30	22.30	67.10	1	DIMP	50
9.10	15.00	1.85	4.95	30.90	2	DIMP	100
25.30	29.80	14.90	21.50	91.50	1	DCPD	100
51.20	35.70	30.5	17.40	134.80	1	DCPD	300
4.50	4.85	2.40	14.00	25.75	2	DCPD	500
7.95	17.55	13.60	13.25	52.35	2	DCPD	700
4.85	13.00	8.05	13.65	39.55	2	DCPD	1000

^aThe 700 and 1000 ppm alfalfa plants did not survive the experiment.

10 11 12 13 14 15 16 17 18 19 20 21 22 23 24 25 26 27 28 29 30 31 32 33 34 35 36 37 38 39 40 41 42 43 44 45 46 47 48 49 50 51 52 53 54 55 56 57 58 59 60 61 62 63 64 65 66 67 68 69 70 71 72 73 74 75 76 77 78 79 80 81 82 83 84 85 86 87 88 89 90 91 92 93 94 95 96 97 98 99 100

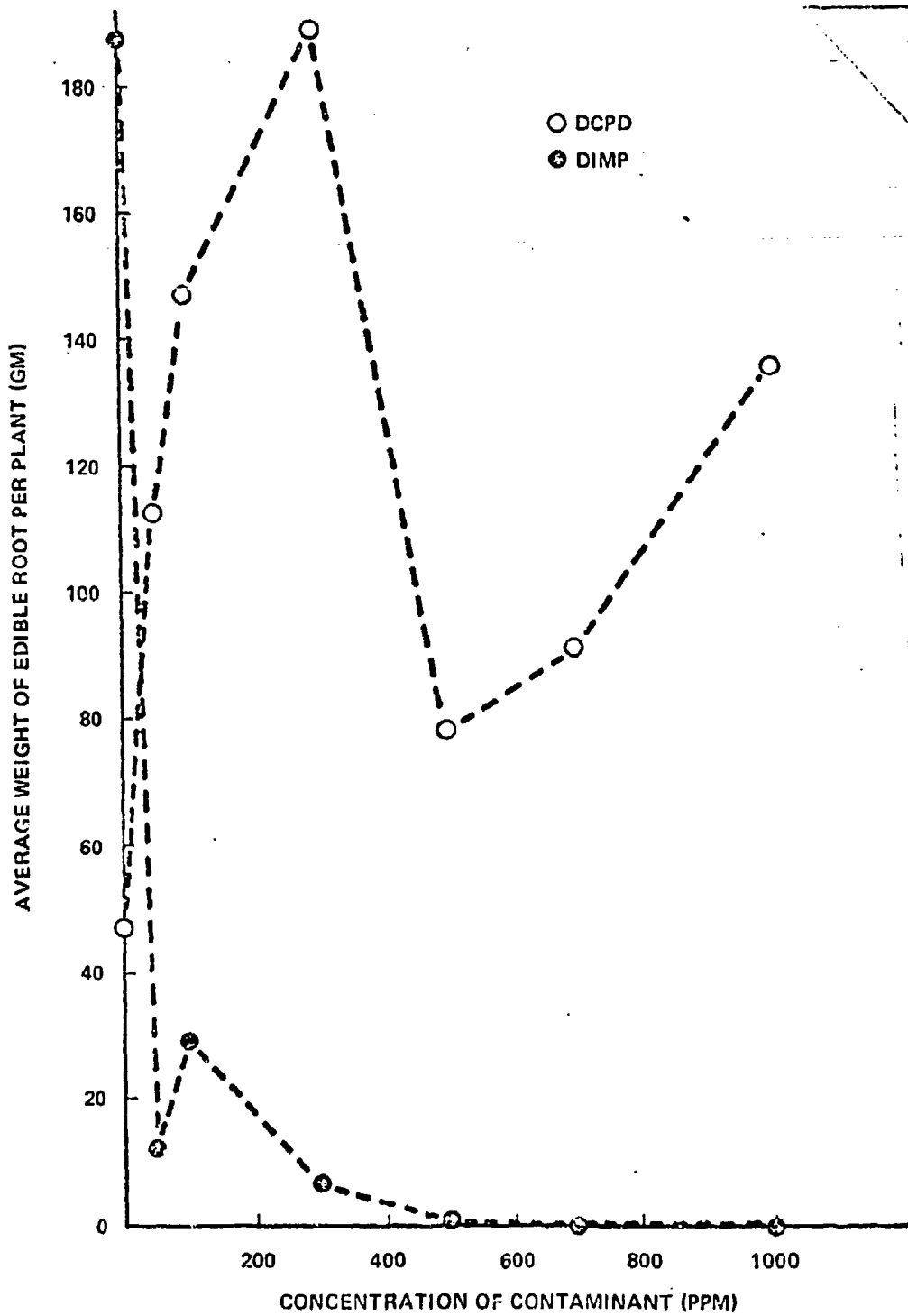

Figure 30. Average Yield of Sugar Beets Irrigated with DIMP or DCPD Contaminated Water.

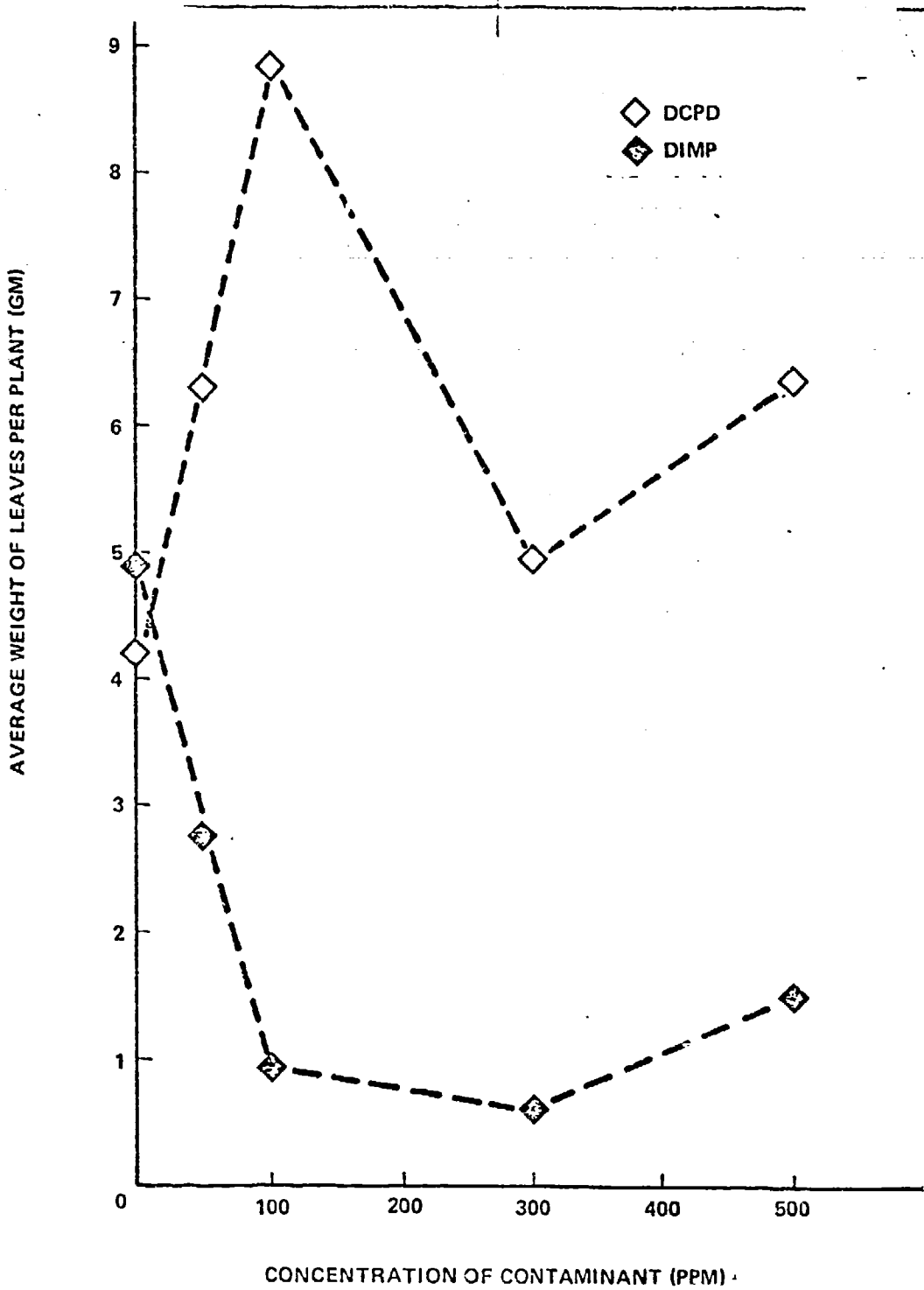

Figure 31. Average Yield of Alfalfa Irrigated with DIMP or DCPD Contaminated Water.

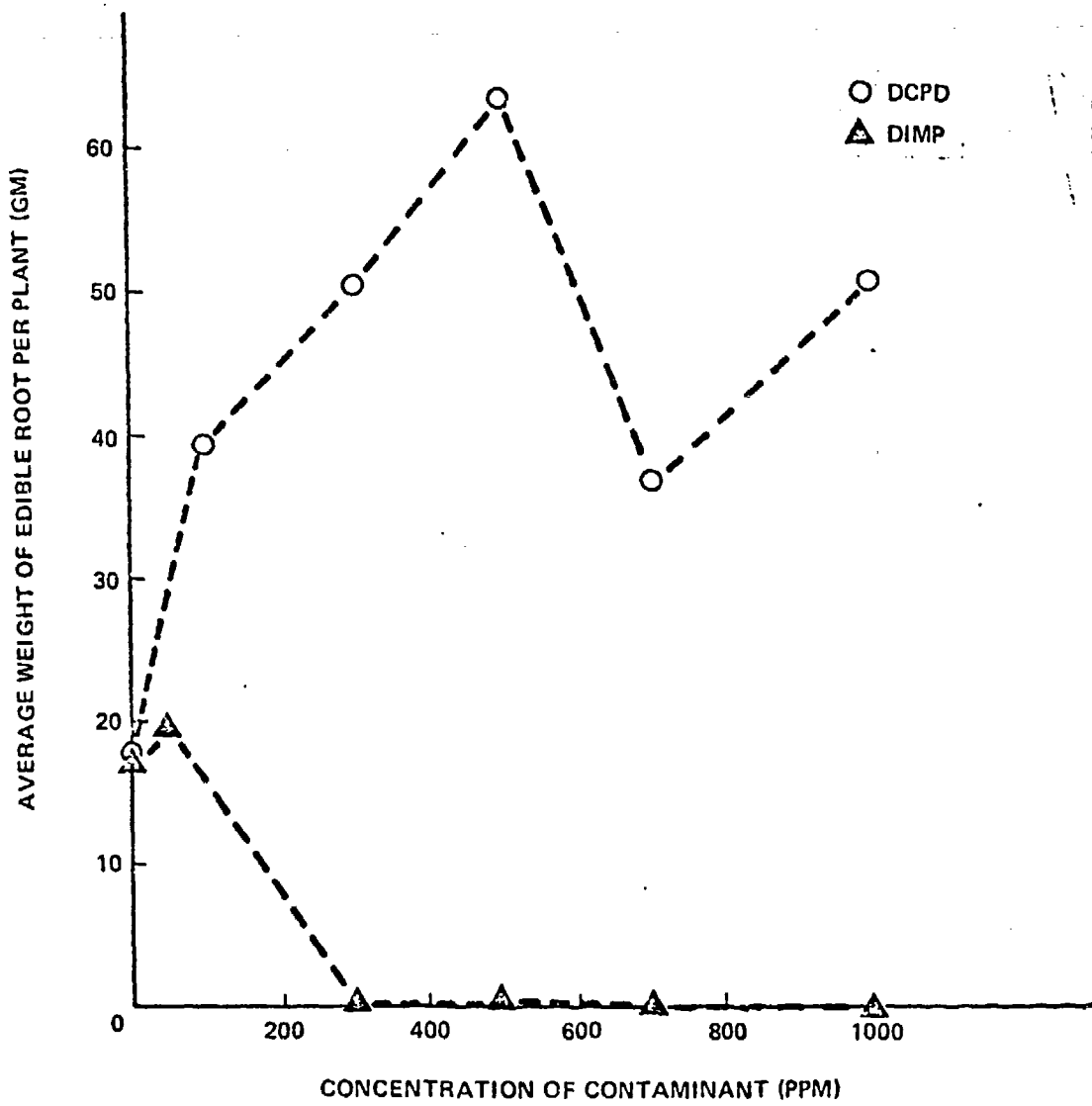

Figure 32. Average Yield of Carrots Irrigated with DIMP or DCPD Contaminated Water.

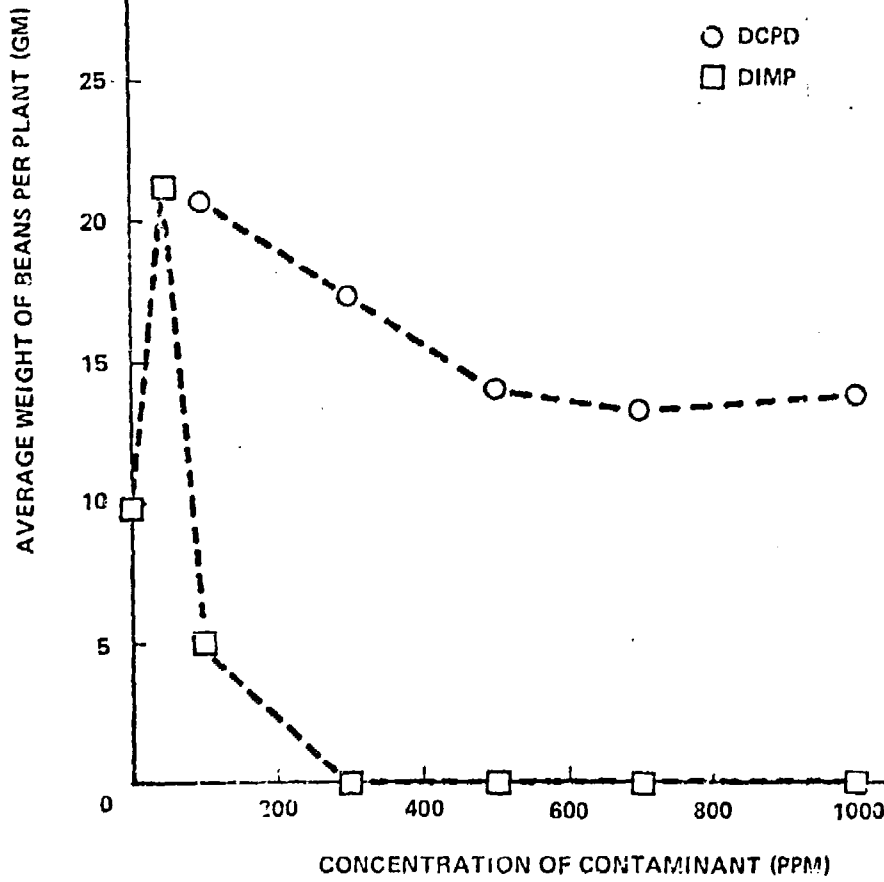

Figure 33. Average Yield of Beans Irrigated with DIMP or DCPD Contaminated Water.

As a check on the efficiency of irrigation in the soil pots, soil samples from four different locations in each of the sugar beet pots at surface 1/8 in., 1/8 to 6 in., and 6 to 12 in. were taken and analyzed for DIMP content. The data from these analyses are shown in Table 8.

2.3.2 Bioconcentration Studies

Bioconcentration, or the takeup by a growing plant of a contaminant from its environment and increasing its concentration in the tissues of the plant, has been demonstrated in the case of DIMP, which is relatively water soluble (Table 1).

The term used here to indicate the relative intensity of this phenomenon is bioconcentration factor defined as the ratio between the concentration of contaminant in harvested plant tissues to the concentration in the nutrient solution or irrigation water. This is demonstrated in Table 9, which lists the bioconcentration factors for fresh-cut tomato leaves at various stages in their growing cycles. These data are plotted in Figure 34.

Table 8. Soil Analysis for DIMP From Sugar Beet Test Pots (After 210-Day Irrigation).

Sample Depth (in.)	Concentration of DIMP From Sugar Beet (ppm)		
	From 1 ppm	From 8 ppm	From 20 ppm
Surface - 1/8	a	2.9	19.2
Surface - 1/8	a	3.3	18.6
Surface - 1/8	a	1.4	15.9
Surface - 1/8	a	2.2	11.0
1/8 - 6	a	1.8	4.9
1/8 - 6	a	2.4	4.8
1/8 - 6	a	1.6	6.1
1/8 - 6	a	1.9	5.1
6 - 12	a	3.0	6.1
6 - 12	a	a	6.2
6 - 12	a	a	7.1
6 - 12	a	a	8.0
a < 0.1 ppm			

Table 9. Hydroponic Tomato Leaf Bioconcentration Factors (DIMP)--Fresh-Cut Basis.

Time from Inoculation (Days)	Plant Bioconcentration Factors			
	Nutrient Bath (ppm)			
	1	10	100	1000
13	10.4	5.5	5.0	15.1
15				
41	10.1	3.9	4.8	
54			2.5	
61		1.2		
88	0.3	0.7	8.3	
149	0	3.9	3.6	

A trend appears in all the plants that showed bioconcentration; that is, the accumulation is rapid at first and then falls off as the plant matures. Continuing the experiment to a point where the plants begin to wither frequently gives increasing values, again probably because of the withering plants drying out. The peak of accumulation for most plants occurs in the first month or so of life; however, wheat leaves and corn leaves showed maxima at about 3 months, as shown in Figure 35.

In previous classified work with radioactive tracers, the tips of corn leaves showed concentration of certain organic phosphorous compounds to a much greater extent than did other plant parts. The data in Figure 35 are consistent with this observation.

Figure 36 shows the same sort of information for carrot and meadow fescue leaves. Data for leaves are emphasized here because generally the leaves showed the greatest concentration of chemical agents while the other plant parts typically did not concentrate or did so in a very limited manner. This phenomenon is demonstrated in Table 10 for 1000 ppm exposures. These data are shown graphically in Figure A-1 and A-2 of Appendix A.

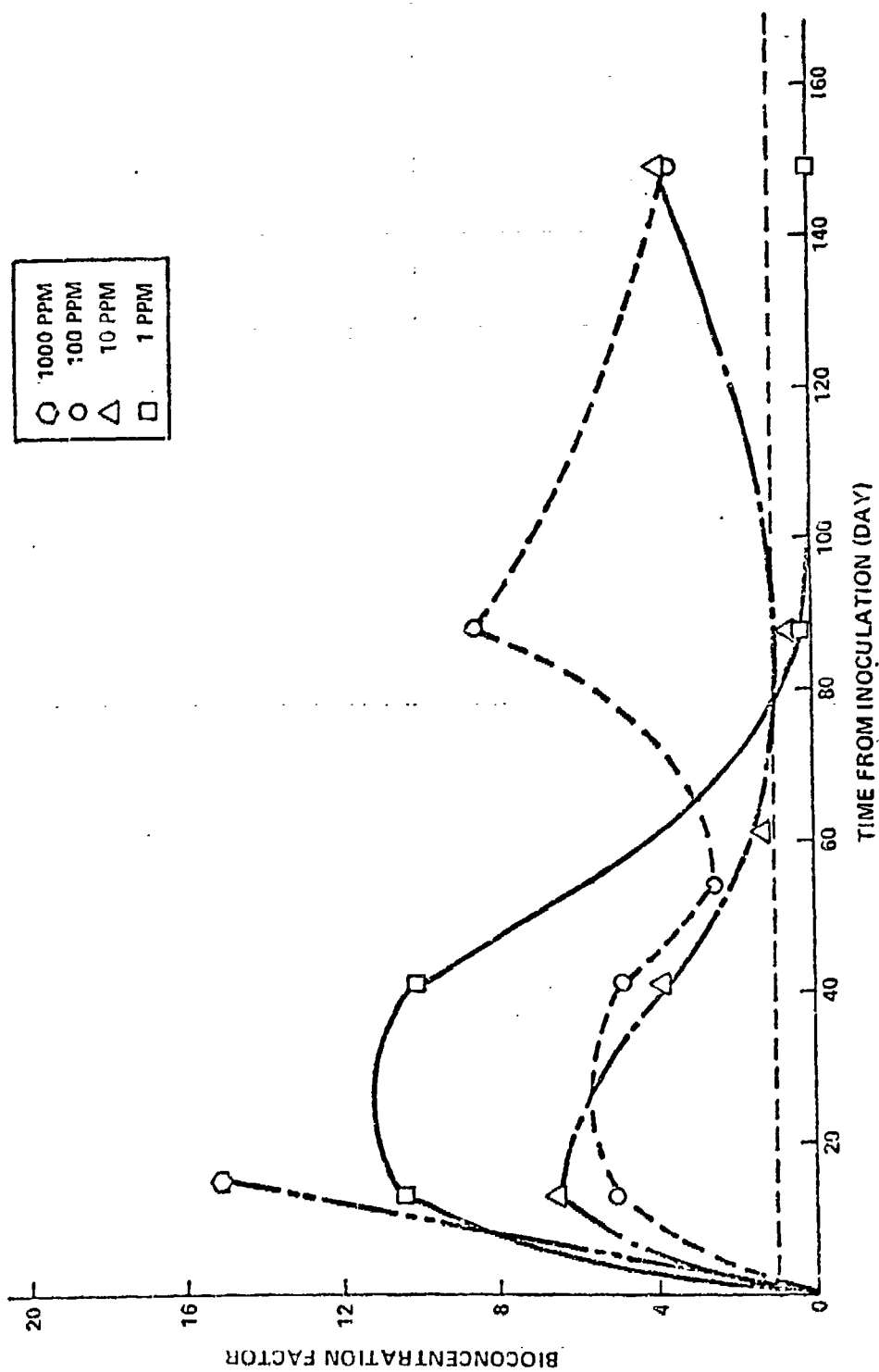

Figure 34. Bioconcentration of DIMP in Tomato Leaves.

1
2
3
4
5
6
7
8
9
10
11
12
13
14
15
16
17
18
19
20
21
22
23
24
25
26
27
28
29
30
31
32
33
34
35
36
37
38
39
40
41
42
43
44

1
2
3
4
5
6
7
8
9
10
11
12
13
14
15
16
17
18
19
20
21
22
23
24
25
26
27
28
29
30
31
32
33
34
35
36
37
38
39
40
41
42
43
44

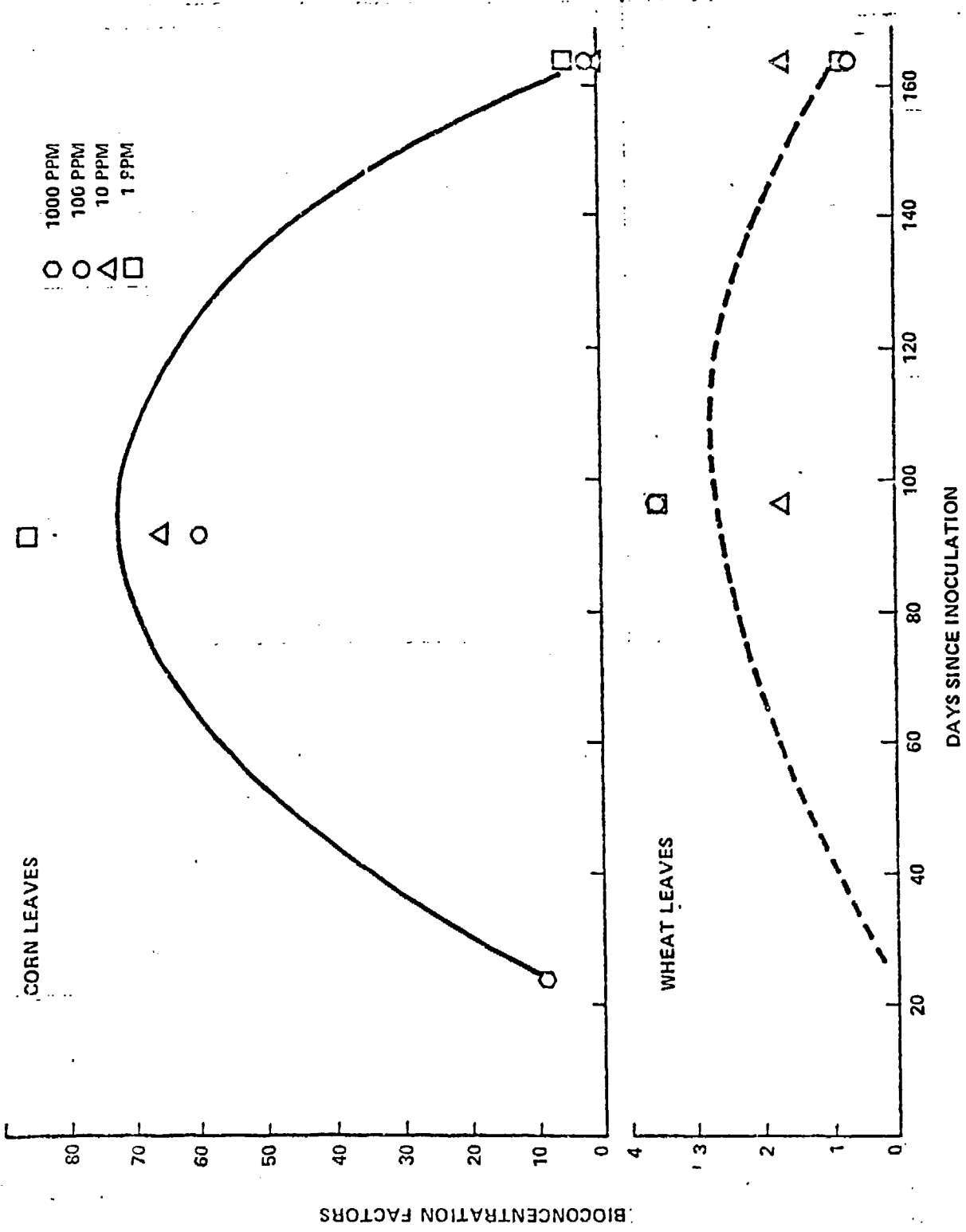

Figure 35. Bioconcentration of DIMP in Hydroponically Grown Plant Tissues (I)

- 1
- 2
- 3
- 4
- 5
- 6
- 7
- 8
- 9
- 10
- 11
- 12
- 13
- 14
- 15
- 16
- 17
- 18
- 19
- 20
- 21
- 22
- 23
- 24
- 25
- 26
- 27
- 28
- 29
- 30
- 31
- 32
- 33
- 34
- 35
- 36
- 37
- 38
- 39
- 40
- 41
- 42
- 43
- 44

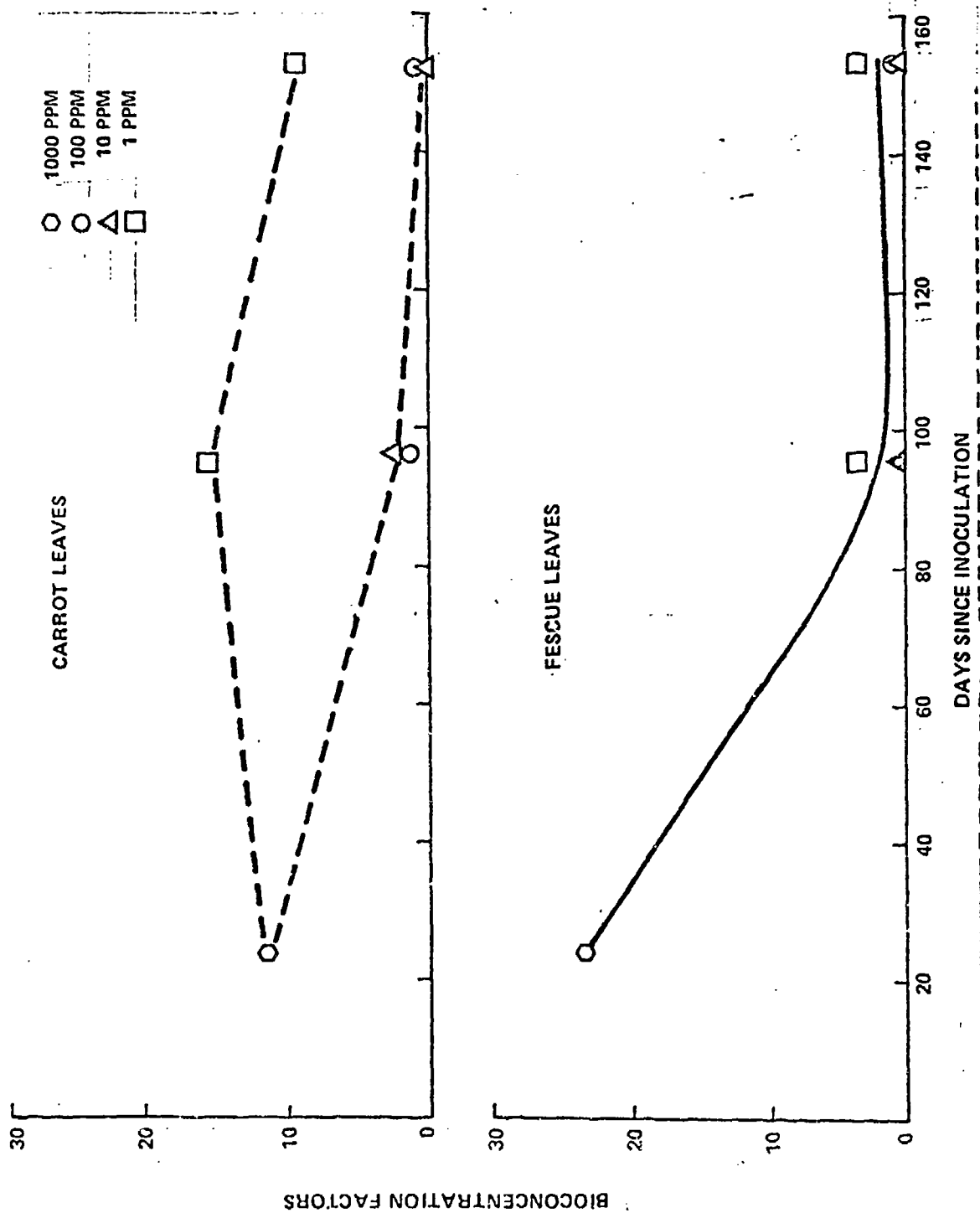

Figure 36. Bioconcentration of DIMP in Hydroponically Grown Plant Tissues (2)

Table 10. DIMP Content of Plant Parts from
1000 ppm Nutrient -- 22 to 25 Day Exposure.

Plant Type	DIMP Concentration (ppm)		
	Leaf	Stem	Root
Tomato*	15,213	3040	4674
Corn	8,918	8993	1703
Bean*	8,000	2018	729
Radish	5,231	1000	2935
Fescue	2,329	134	208
Sugar beet	1,851	208	30
Carrot	1,137	541	52
Rose	613	42	136
Wheat	192	**	3
Juniper	53	**	**
* 15 Days			
** Not processed			

1 An overall view of the various concentrations and plant parts of the hydro- 1
2 ponically grown radish is shown in Table 11. Here again the leaf is shown 2
3 to have greater concentration than the rest of the plant. The same type of 3
4 data for beans is shown in Table 12. Information from these tables is shown 4
5 graphically in Figures A-3 and A-4 of Appendix A. 5
6

7 The values reported for DIMP content have been calculated on a fresh-cut 7
8 sample weight basis. It is possible that some data could be biased if there 8
9 were significant variation in the amount of water in the plant tissues. To 9
10 examine this possibility, a per cent dry weight analysis of chopped leaf 10
11 tissue from the various plants was run at 96 days. Table 13 is a summary of 11
12 the data from this analysis. There is not a significant variation in moisture 12
13 content within a species although there is some difference between species. 13
14

15 Calculating the DIMP content of the plants on a dry-weight basis would 15
16 increase the measured bioconcentration factors by some degree. A summary 16
17 of bioconcentration factors on a dry-weight basis compared to a fresh-cut 17
18 basis is shown in Table 14 for various parts of the tomato plant. 18
19

20 Chemical analysis of the plants from this series has been performed at 20
21 several time intervals. Data on sugar beet, carrot, bean, and wheat after 21
22 37 days exposure are shown in Table 15. This shows the bioconcentration 22
23 factor for DIMP as defined before, ranging from 7.5 to just under 2 in the 23
24 leaves. These data are plotted in Figure A-5, Appendix A. These numbers 24
25 may not be as dramatic as some of those in the hydroponic tests, perhaps 25
26 because the hydroponic system presented essentially a constant and available 26
27 supply of DIMP while the soil restricted the availability of the chemical to 27
28 the roots. Further measurements of yield and bioconcentration were made 28
29 as these plants matured. Tables 16, 17, and 18 show their condition at 29
30 65 days. These data are plotted in Figures A-6, A-7, and A-8 of Appendix A. 30
31

32 Terminal analyses of plant bioconcentration at the time of plant harvest were 32
33 made. Results from these analyses are shown in Table 19 and graphically 33
34 plotted in Figures A-9, A-10, and A-11 of Appendix A. 34
35

36 For practical analytical purposes, analyzing the fresh cut tissue is more 36
37 realistic because of the loss of DIMP in the drying process. The data in 37
38 Table 13 were obtained by finely chopping the leaf tissue and drying to constant 38
39 weight in a 105°C forced air oven. The loss of DIMP can be illustrated by 39
40 an experiment run on mixed sections of the same tomato leaves treated in 40
41 two different ways. The fresh sample from the 10 ppm bath gave a tissue 41
42 concentration of 258.3 ppm DIMP. The dried sample gave a concentration of 42
43 774.3 ppm. Since the 10 ppm tomato leaf had a water content of 89.4% the 43
44 dry leaf DIMP concentration should have been 2438.7 ppm if no DIMP was 44

Table 11. DIMP Content of Radish Parts after 28-Day Exposure.

Plant Part	Concentration of DIMP in Nutrient (ppm)	Concentration of DIMP in Plant (ppm)	Bioconcentration Factor
Leaf	1.0	12.05	12.0X
Leaf	10.0	48.3	4.8X
Leaf	100.0	957.6	9.6X
Leaf*	1000.0	5231.0	5.2X
Fleshy root	1.0	0.3	0.3X
Fleshy root	10.0	7.3	0.7X
Fleshy root	100.0	175.0	1.8X
Fleshy root	1000.0	1000.0	1.0X
Fibrous root	1.0	2.3	2.3X
Fibrous root	10.0	9.7	1.0X
Fibrous root	100.0	109.0	1.1X
Fibrous root*	1000.0	2935.0	2.9X

*22-day exposure.

Table 12. DIMP Uptake in Bean Plants after 48-Day Exposure Bioconcentration Factor.

Nutrient DIMP Concentration (ppm)	Leaf	Fruit*	Stem	Root
1	4.79	0.5	1.32	0.74
10	1.85	0.2	0.51	0.29
100	2.10	0.6	0.65	0.44

*Fruit = filled bean pod.

Table 13. Percent Moisture of Harvested Plant Leaves on Day 96.

NDC (ppm) / Plant Type	Percent Moisture				
	Control	1	10	100	1000
Carrot	84.1	85.3	87.3	80.4	**
Corn	82.1	80.4	84.1	78.7	**
Sugar beet	90.0	90.6	89.9	83.0	**
Fescue	85.5	85.4	86.3	86.9	**
Wheat	80.0	81.6	76.2	77.1	**
Tomato	88.5	89.5	89.4	87.6	**
Rose	74.1	75.9	76.8	70.5	**
Juniper	58.5	60.3	59.1	56.3	55.6

*Nutrient DIMP Concentration
 **Plants did not survive.

Table 14. Bioconcentration of DIMP in Harvested Tomato Plant Parts -- 149 Days from Original Inoculation.

Plant Part	DIMP Concentration In Bath (ppm)	Net DIMP Concentration in Tissue (ppm)		Bioconcentration Factor	
		Wet Basis	Dry Basis	Wet	Dry
Fruit	1.0	0	0	0	0
Fruit	10.0	17.4	167.3	1.7	17.0
Fruit	100.0	*	*	*	*
Leaf	1.0	0	0	0	0
Leaf	10.0	38.5	350.0	3.9	35.0
Leaf	100.0	363.2	2124.0	3.6	21.0
Root	1.0	0	0	0	0
Root	10.0	70.5	870.0	7.1	87.0
Root	100.0	70.9	834.0	0.7	8.3
Stem	1.0	0	0	0	0
Stem	10.0	6.0	55.0	0.6	5.5
Stem	100.0	70.3	717.0	0.7	7.2
* No fruit produced					

1953-01(01)FP

Table 15. Bioconcentration of DIMP by Plant Parts in 20 ppm Irrigation -- 37 days from Original Inoculation.

Plant Part	Total DIMP added to Pot		DIMP Concentration in Tissue (ppm)	Bioconcentration Factor
	Volume of 20 ppm Irrigation (cc)	Weight of DIMP (mg)		
Sugar beet	9500	190		
Root			45.6	2.28
Stem			37.1	1.86
Leaf			129.2	6.46
Carrot	9200	184		
Root			12.4	0.62
Stem			6.6	0.33
Leaf			36.9	1.85
Bean	9200	184		
Root			45.4	2.27
Stem			28.9	1.45
Leaf			150.0	7.50
Wheat	9200	184		
Root			31.5	1.58
Stem			14.2	0.71
Leaf			105.5	5.28

Table 16. Bioconcentration of DIMP in Plant Parts -- 65 Days from 20-ppm Initial Inoculation.

Plant Part	Volume of Irrigation Solution (ml)	Weight of DIMP Added (mgm)	Total DIMP Added		DIMP Concentration in Fresh Tissue (ppm)	Bioconcentration Factor (x)
			38	39		
Sugar beet Root Stem Leaf	15,000	300	38	39	17.8	0.9
			40	41	26.9	1.3
			42	43	56.9	2.8
Carrot Root Stem Leaf	15,000	300	38	39	7.6	0.4
			40	41	8.4	0.4
			42	43	111.4	5.6
Bean Root Stem Leaf	15,000	300	38	39	81.0	4.1
			40	41	65.1	3.2
			42	43	120.5	6.0
Wheat Root Stem Leaf	15,000	300	38	39	22.0	1.1
			40	41	9.6	0.5
			42	43	106.3	5.3
A.falfa Root Stem Leaf	15,000	300	38	39	6.9	0.3
			40	41	6.7	0.3
			42	43	43.6	2.2

Table 17. Bioconcentration of DIMP in Plant Parts -- 65 Days from 8-ppm Initial Inoculation.

Plant Part	Total DIMP Added to Container		DIMP Concentration in Fresh Tissue (ppm)	Bioconcentration Factor (x)
	Volume of Irrigation Solution (ml)	Weight of DIMP Added (mgm)		
Sugar beet Root Stem Leaf	15,000	120	4.0	0.5
			6.0	0.8
			10.6	1.3
Carrot Root Stem Leaf	15,000	120	7.2	0.9
			10.2	1.3
			17.5	2.2
Ebean Root Stem Leaf	15,000	120	46.1	5.8
			28.8	3.6
			41.3	5.2
Wheat Root Stem Leaf	15,000	120	*	*
			*	*
			85.5	10.7
Alfalfa Root Stem Leaf	15,000	120	4.9	0.6
			9.6	1.2
			30.6	3.8

* = 0.1 ppm

Table 18. Bioconcentration of DIMP in Plant Parts -- 65 Days from 1-ppm Initial Inoculation

Plant Part	Total DIMP Added to Container		DIMP Concentration in Fresh Tissue (ppm)	Bioconcentration Factor (x)
	Volume of Irrigation Solution (ml)	Weight of DIMP Added (mgm)		
Sugar beet Root Stem Leaf	15,000	15	*	*
			*	*
			*	*
Carrot Root Stem Leaf	15,000	15	2.1	2.0
			3.0	3.0
			2.9	2.9
Bean Root Stem Leaf	15,000	15	8.5	8.5
			0.9	0.9
			2.9	11.0
Wheat Root Stem Leaf	15,000	15	4.4	4.4
			3.9	3.9
			*	*
Alfalfa Root Stem Leaf	15,000	15	1.3	1.3
			5.1	5.1
			4.0	4.0

* < 0.1 ppm

Table 19. Bioconcentration of DIMP by Plant Parts (Terminal). (Sheet 1 of 3)

Plant Part	Total DIMP Added to Pot		Days From Original Inoculation	DIMP Concentration in Tissue (ppm)	Bioconcentration Factor
	Volume of 20 ppm Irrigation (cc)	Weight of DIMP (mg)			
20 PPM IRRIGATION					
Sugar Beet	49,300	986	196		
Root				11	0.6
Stem				a	a
Leaf				65	3.3
Carrot	52,700	1054	225		
Root				13	0.7
Stem				27	1.4
Leaf				69	3.5
Bean	17,100	342	65		
Root				81	4.1
Stem				63	3.2
Leaf				121	6.0
Wheat	17,100	342	65		
Root				22	1.1
Stem				10	0.5
Leaf				106	5.3
Alfalfa	23,400	468	115		
Root				5	0.3
Stem				b	a
Leaf				24	1.2
8 PPM IRRIGATION					
Sugar Beet	49,300	394	196		
Foot				b	0.6
Stem				a	a
Leaf				24	3.0

Table 19. Bioconcentration of DIMP by Plant Parts (Terminal). (Sheet 2 of 3)

Plant Part	Total DIMP Added to Pot		Days From Original Inoculation	DIMP Concentration in Tissue (ppm)	Bioconcentration Factor
	Volume of 20 ppm Irrigation (cc)	Weight of DIMP (mg)			
Carrot	52,700	422	225	1	0.3
Root					
Stem					
Leaf	17,100	137		17	2.1
Bean					
Root					
Stem	17,100	137		29	3.6
Leaf					
Leaf					
Wheat	23,400	184	115	c	a
Root					
Stem					
Leaf	11	6	21	86	10.7
Alfalfa					
Root					
Stem	11	6	21	11	1.4
Leaf					
Leaf					
1 PPM IRRIGATION					
Sugar Beet	49,300	49	196	c	a
Root					
Stem					
Leaf	52,700	53	225	1	1
Carrot					
Root					
Stem	1	10		1	10
Leaf					
Leaf					

Table 19. Bioconcentration of DIMP by Plant Parts
(Terminal). (Sheet 3 of 3)

Plant Part	Total DIMP Added to Pot		Days From Original Inoculation	DIMP Concentration in Tissue (ppm)	Bioconcentration Factor		
	Volume of 20 ppm Irrigation (cc)	Weight of DIMP (mg)					
Bean	17,000	17					
Root						9	9
Stem						1	1
Leaf				3	3		
Wheat	17,100	17					
Root						4	4
Stem						4	4
Leaf				c	a		
Alfalfa	23,400	23	115				
Root						c	a
Stem						c	a
Leaf				c	a		
a No sample							
b None detected							
c <0.1 ppm							

1 lost in the drying process. This calculation indicates that approximately 75%
2 of the DIMP was not extracted from the dried tissue either because of vaporization,
3 fixation, or chemical conversion.

4 This same characteristic has been noted before for DCPD, in which approximately
5 50% of the DCPD was lost in a concentrating step in the analysis of a
6 standard solution.

7
8 Analyses of the plants exposed to DCPD revealed no traces of the material in
9 these samples. One of the difficulties in administering this contaminant to
10 the plants was the lack of solubility of DCPD in water. The 10 ppm solution
11 appeared to be homogeneous but all of the other concentrations resulted in
12 a waxy film of DCPD of varying thickness on the surface of the solution.
13 This film appeared to vanish with time and was replenished upon subsequent
14 additions of DCPD to the nutrient baths as described earlier. Addition of
15 solubilizing agents to the DCPD baths was avoided in these experiments to
16 preclude additional unknown factors that would not be present in any naturally
17 occurring contamination.

18
19 The analytical system (extraction/chromatography) has been shown capable
20 of recovering standard additions of DCPD to plant material at 100 ppm.
21 The conclusion then as to absorption of DCPD in the plants is that probably
22 it is at too low a level to be detected by our presently used techniques. This
23 effectively eliminates consideration of bioconcentration of DCPD in the hydro-
24 ponic system and without solubility aids.

25 26 27 28 2.4 DISCUSSION

29 30 31 2.4.1 DIMP

32 The data generated by this study have shown that there is a phytotoxic effect
33 on the plants treated with DIMP. Those plants receiving relatively high
34 concentrations of DIMP in their nutrient solution or irrigation water show
35 definite signs of plant tissue damage. As the concentration of DIMP approach-
36 es zero the symptoms of phytotoxicity become less pronounced until they
37 became indistinguishable from those caused by normally encountered envi-
38 ronmental stresses on the plants.

39
40 Such symptoms as leaf curl and tip burn could also be indicative of deficiencies
41 in trace elements in the plant irrigation medium but controlled solution
42
43
44

1 preparation, thermostatted greenhouses, and uniformity of irrigation should
2 eliminate enough variations in plant to plant treatment to produce these
3 symptoms. A certain amount of plant to plant variation exists because of plant
4 position in the greenhouse. Proximity of walls, heaters, coolers, shade, or
5 sun can cause variations within species.

6
7 The phenomenon noted with some plants in which a small dose of DIMP pro-
8 duced enhanced growth whereas a larger dose produced phytotoxic symptoms
9 also creates a certain amount of ambiguity in the evaluation of symptoms.

10
11 Taking all of the above into consideration, estimates were made of the phyto-
12 toxic effect/no effect level in the hydroponic system. Based upon these
13 estimates contamination levels were chosen for the soil culture tests which
14 it was felt should have resulted in an effect level, a no-effect level, and one
15 somewhere in between.

16
17 As the soil growth experiments matured it appeared that the contamination
18 levels chosen for the demonstration of effect level were not high enough to
19 show such an effect.

20
21 The data from the initial soil growth experiments were examined to establish
22 some relationship between dose level and phytotoxicity. From the purely
23 visual evaluation no symptoms were evident which could be tied directly to
24 dose level. As for harvestable plant weights we may conclude that in some
25 cases the nominal contaminants are actually growth promoters. The only
26 evidence available from the strictly statistical point of view are the yields
27 of the positive control plants. These vary so widely one from another that
28 it can only be concluded that plant-to-plant variation is so great as to com-
29 pletely mask the results of the treatment. In other words, the signal-to-
30 noise ratio is very low.

31
32 A much more extensive series of experiments, from the point of numbers of
33 plants and contaminant concentration levels, would be required to enable
34 mathematical statements of the effects of DIMP on plant growth.

35
36 From the supplemental, broad range soil growth experiments, we can con-
37 clude from visual evaluation of symptoms, mainly browning of the leaves
38 and stunting of the plants, that a level of DIMP in the irrigation water between
39 100 and 300 ppm during the early stages of development and down to approx-
40 imately 50 ppm as the plants approach maturity causes such symptoms to
41 appear.

42
43 It has also been shown that the bioconcentration of DIMP occurs at all levels
44 of DIMP application mainly in the leaf tissue. This concentration is not

so evident in the portions of the plants normally directly consumed by human beings, e.g., carrot and beet root, bean pods and seeds.

Portions of the plants which have use as animal fodder, most especially the leaves, show concentration factors which indicate that such material could enter the food chain by way of animal feed.

The significance of the absolute quantities of DIMP ingested in terms of human or animal health must be ascertained by further investigations into the actual human and animal toxicity of this compound. Included in such investigations should be a study of the possible synergistic effect of the possible food matrixes involved and the deposition and concentration of the toxic material in the human or animal organism. One of the observations noted in the broad range soil tests was that the effect level of DIMP became lower as the plant matured. This was probably due in part to the absorption of DIMP from the irrigation water by the soil particles near the surface. Data from the lysimeter tests indicated that DIMP would be accumulated in a concentrated band at the surface of a soil column with the rest of the column, such as the area occupied by the plant roots, receiving a more dilute solution than originally applied. This type of phenomenon may also partially explain the observation that bioconcentration also appears less intense in the soil than in the hydroponic case, in which the plant roots are subject to a higher, more readily available concentration of DIMP.

2.4.2 DCPD

The parallel experiments to those discussed above which substituted DCPD for DIMP led to somewhat different results. As in the case of DIMP, certain visual evidence of phytotoxicity was observed. The overwhelming symptom in this case was stunting of the affected plants rather than the browning reaction so evident with DIMP.

Sensitivity limits in the DCPD analytical scheme coupled with the insolubility of the DCPD in irrigation and nutrient solutions resulted in no quantitative data on plant uptake. An evaluation of the yield of plant material from the soil grown plants in the DCPD case also showed no discernable tissue damage which could be assigned to DCPD uptake. At the irrigation contamination levels used in these tests, <1000 ppm DCPD, no visual symptoms of phytotoxicity were definitely attributable to the contaminant.

Since, in the analytical technique used here, the presence of 100 ppm DCPD was readily detectable we can conclude that in all cases less than that amount

1 was present in all the tissues analyzed. The problem of human or animal
2 toxicity can have that concentration as one of its limiting parameters.

3
4
5
6
7
8
9
10
11
12
13
14
15
16
17
18
19
20
21
22
23
24
25
26
27
28
29
30
31
32
33
34
35
36
37
38
39
40
41
42
43
44

1
2
3
4
5
6
7
8
9
10
11
12
13
14
15
16
17
18
19
20
21
22
23
24
25
26
27
28
29
30
31
32
33
34
35
36
37
38
39
40
41
42
43
44

Section 3

SOIL STUDIES

3.1 OBJECTIVES

Another general area of study under this contract is the determination of mobility or stability characteristics of the contaminant chemicals in soil. Contamination of soil at given installations can be determined and appropriate action taken with one degree of urgency if contaminant migration can be demonstrated to be insignificant. Significant rates of migration, on the other hand, indicate need for a more expeditious approach to prevent problems of contamination of adjoining property.

Measurable migration of contamination through the soil also bears upon the subsequent agricultural use of the area. Removal of a contaminant from the local soil by irrigation could be, in some cases, a preliminary to returning the area to agricultural production of edible foodstuffs.

Preliminary analytical experiments indicated that there was a greater chance of successful analysis in the case of DIMP and therefore the bulk of the lysimeter migration studies was run with this compound.

An additional series of bench top experiments was performed, the objective of which was to determine the significance of volatility of DIMP or DCPD from soil. These tests used radioactive tracer techniques in their execution.

3.2 MATERIALS AND METHODS

3.2.1 Lysimeter Studies

3.2.1.1 Lysimeter Design and Construction

The lysimeters used in these experiments are shown in Figure 37. They consist of cylindrical steel containers, epoxy coated on the inside. The containers are 22 3/8 in. inside diameter by 70 in. high and were placed in two groups of five each on wooden stands constructed in accordance with the drawing in Figure 38. Each of the lysimeters had a screened cover (Figure 39) to afford protection from rainfall and local wildlife while leaving free air circulation over the surface.

1953-01(01)FP

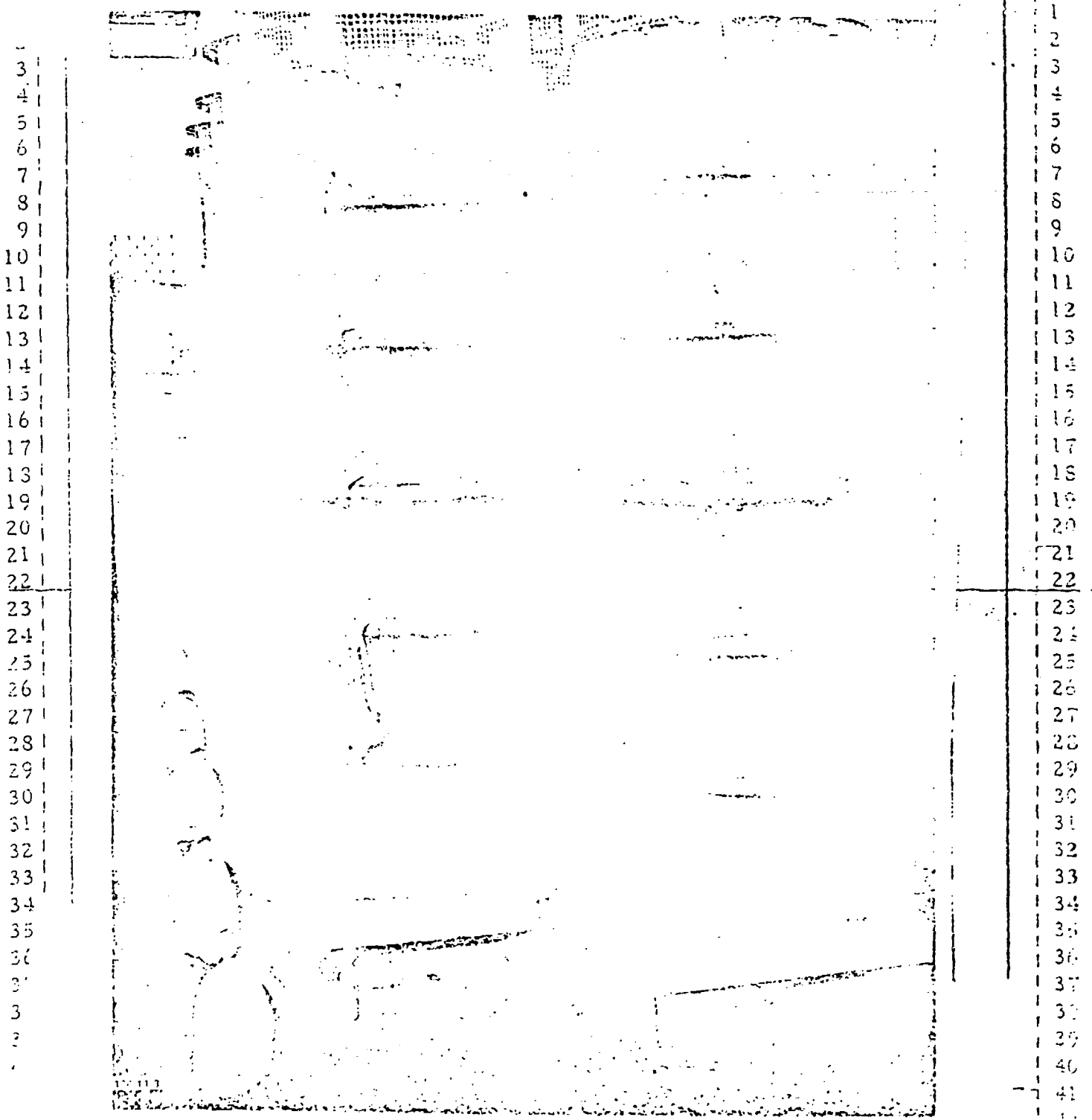

Figure 37. AOMC Lysimeter Setup.

10
11
12
13
14
15
16
17
18
19
20
21
22
23
24
25
26
27
28
29
30
31
32
33
34
35
36
37
38

1
2
3
4
5
6
7
8
9
10
11
12
13
14
15
16
17
18
19
20
21
22
23
24
25
26
27
28
29
30
31
32
33
34
35
36
37
38
39
40
41
42
43
44

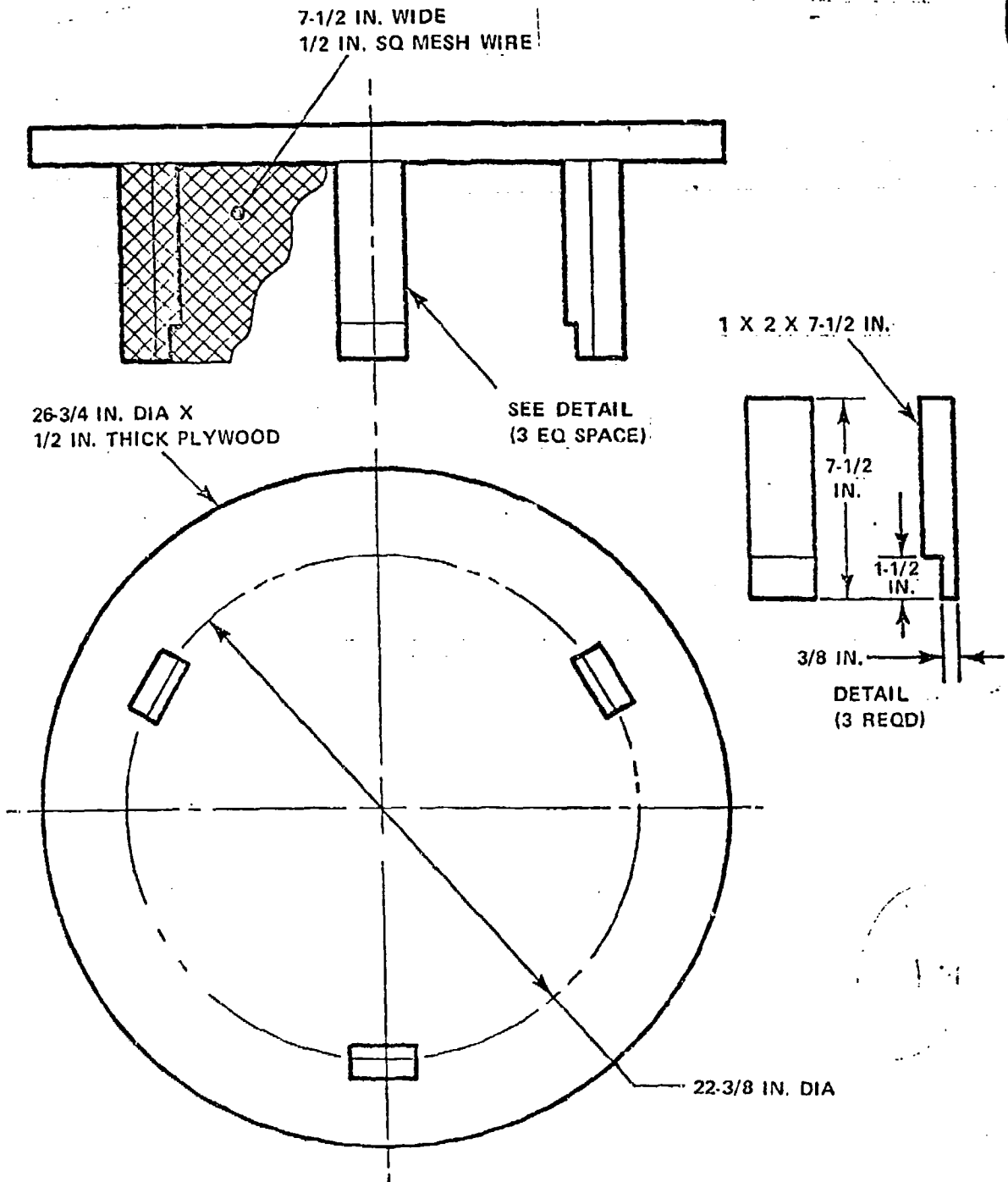

Figure 38. Lysimeter Cover.

1
2
3
4
5
6
7
8
9
10
11
12
13
14
15
16
17
18
19
20
21
22
23
24
25
26
27
28
29
30
31
32
33
34
35
36
37
38
39
40
41
42
43
44

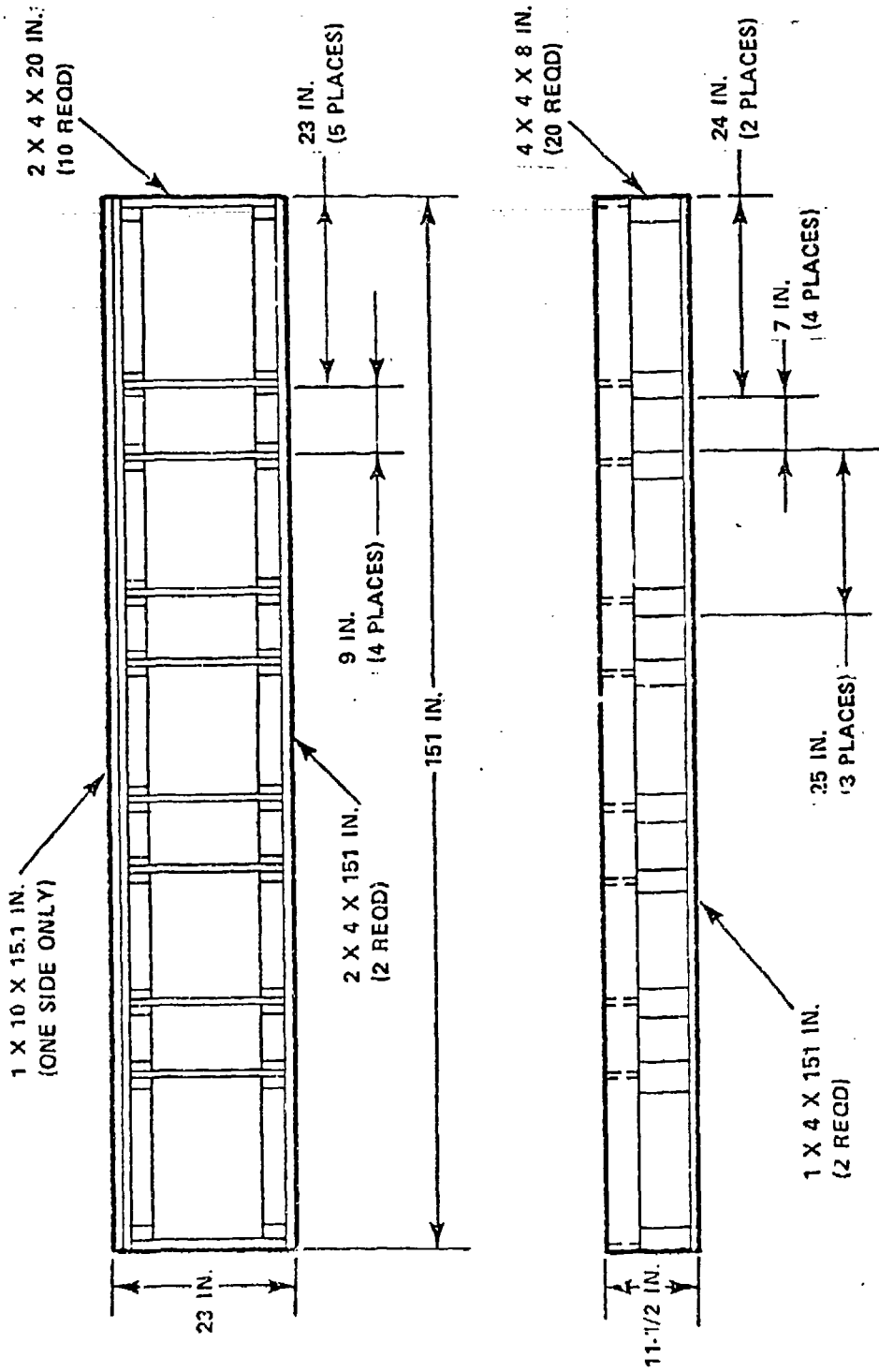

Figure 39. Lysimeter Stand.

1
2
3
4
5
6
7
8
9
10
11
12
13
14
15
16
17
18
19
20
21
22
23
24
25
26
27
28
29
30
31
32
33
34
35
36
37
38
39
40
41
42
43
44

1	Soil solution access tubes (The Irrometer Company, Riverside, California)	1
2	normally used in tensiometer applications were inserted approximately	2
3	1 ft into the soil bed at Points 6, 18, 30, 42, and 54 in. below the surface	3
4	level. These tubes (Figure 40) consisted of porous ceramic cups attached	4
5	coaxially to 1/2 in. diameter polyvinyl tubing. Ground water which collected	5
6	in these tubes was drained out into sample jars on a weekly basis and subjected	6
7	to chromatographic analysis. The soil columns inside the lysimeters were	7
8	supported by a 6 in. deep layer of washed pea gravel which rested on the	8
9	inside bottom of the apparatus. A drain valve at the center bottom allowed	9
10	ground water which had traversed the 60 in. soil depth to be subsequently	10
11	sampled and analyzed.	11
12		12
13	Soil core samples were taken with the tool shown in Figure 11. This is an	13
14	Oakfield, Wisconsin pattern soil sampler Model No. 1238N-DB with extensions	14
15	and replaceable tips purchased from Nasco Agricultural Sciences, Modesto,	15
16	California.	16
17		17
18		18
19	3.2.1.2 Soils	19
20		20
21	The two sets of five lysimeters each were packed to a depth of 5 ft with	21
22	reconstructed soil taken from various locations. The technique for pre-	22
23	paring the lysimeter contents consisted of excavating field soils in 1-ft depth	23
24	increments. These increments were held in isolated containers until each	24
25	was separately air dried and ground to pass through a 1/4-in. sieve. These	25
26	dried and sieved portions of soil were then packed into the lysimeter so that	26
27	their final spatial relationships were the same as they held in their natural	27
28	state.	28
29		29
30	The test soils were obtained from various rural locations in Southern Cali-	30
31	fornia (Figure 41). The top 1 ft of each soil sample was analyzed to deter-	31
32	mine the soil types and those used in this study include: (1) Chino -- sandy	32
33	clay loam, (2) Brawley -- clay, (3) Ventura -- clay loam, (4) Fullerton --	33
34	sandy loam, and (5) Walnut -- clay loam. Tables 18 and 21 list the test	34
35	soil characteristics determined in the laboratory, and Figure 42 illustrates	35
36	the position of these soils on a textural classification chart.	36
37		37
38		38
39	The most recent use of the areas sampled for these particular soils were:	39
40	Chino, scl -- rangeland, Brawley c -- unused portion of a USDA Agricultural	40
41	Research Service farm, Ventura cl -- abandoned lemon ranch, Fullerton	41
42	sd -- orange ranch and Walnut cl -- abandoned general agricultural area.	42
43		43
44		44

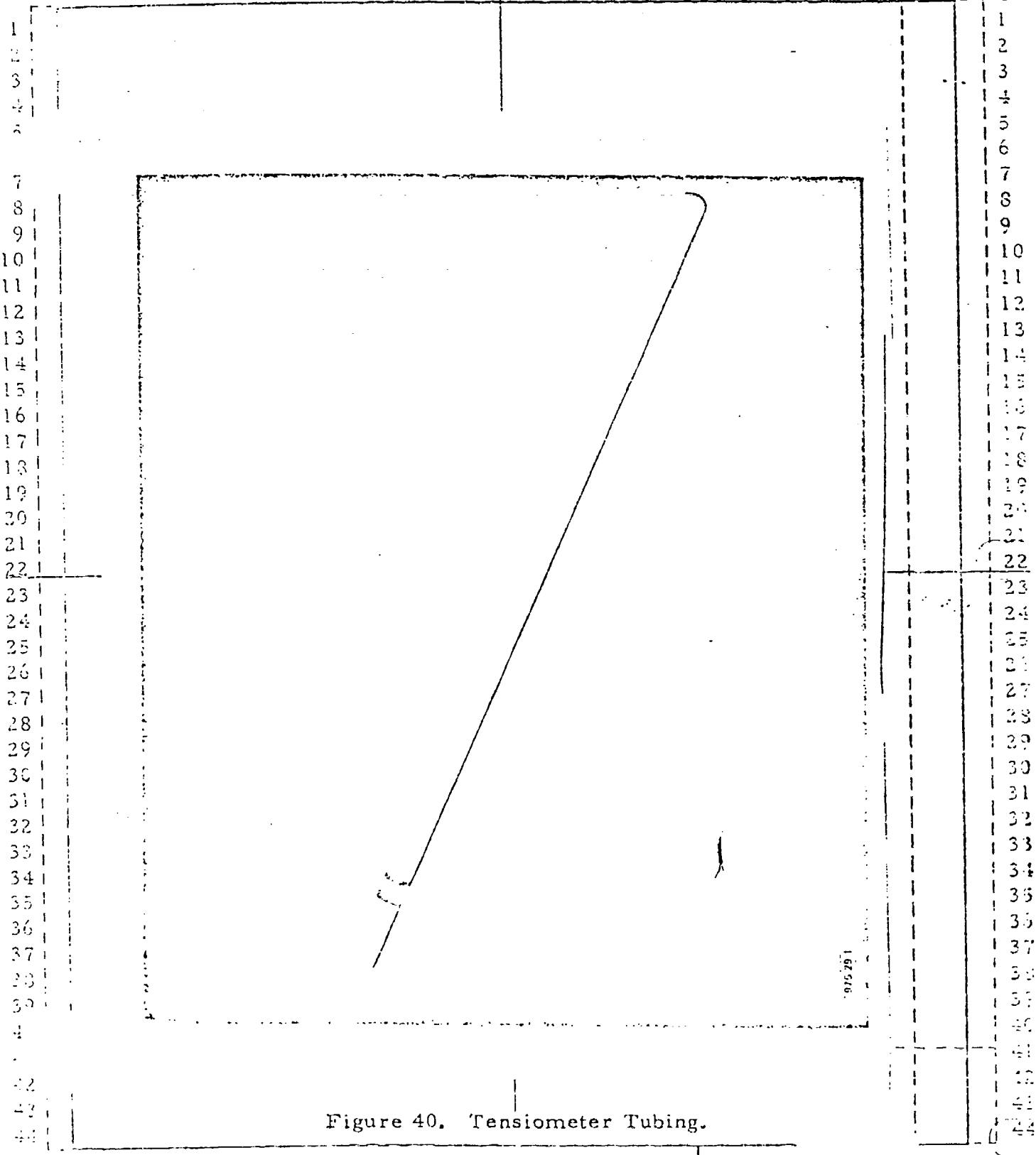

Figure 40. Tensiometer Tubing.

Table 20. Characterization of Lysimeter Sample Soils.

Soil Type	pH	Organic Matter (%)	Sand (%)	Silt (%)	Clay (%)	Moisture Capacity (%)	Exchange Capacity (pH 7) (me/100 gm)
Chino	5.6	3.7	49	26	25	45.4	18.5
Brawley	7.9	0.9	16	25	59	49.8	28.9
Ventura	7.1	1.9	31	42	28	45.1	18.2
Fullerton	6.9	2.2	60	22	18	44.5	16.6
Walnut	6.9	4.1	32	33	34	56.5	37.8

Table 21. Spectrographic Analyses of Top Soil Samples.

Element	Semiquantitative Analysis (%)				
	Brawley	Chino	Fullerton	Ventura	Walnut
Si	23.0	30.0	33.0	28.0	28.0
Al-	11.0	8.5	5.5	8.8	8.7
Fe-	3.3	2.5	2.0	2.4	3.6
Ca-	5.3	2.0	2.4	1.4	2.8
Mg	1.6	0.85	0.69	1.2	1.5
Na-	3.2	4.5	4.5	7.4	5.2
K-	3.7	1.7	2.5	2.9	1.9
Ba-	TR<0.05	0.052	0.054	0.053	0.079
B-	0.0042	ND<0.003	ND<0.003	TR<0.003	ND<0.003
Ti-	0.50	0.42	0.27	0.53	0.57
Pb-	TR<0.01	TR<0.01	TR<0.01	TR<0.01	TR<0.01
Ga-	0.0068	0.0039	0.0032	0.0048	0.0061
Mn-	0.050	0.059	0.055	0.040	0.063
V-	0.0094	0.0084	0.0076	0.0092	0.0087
Cu-	0.0042	0.0030	0.0049	0.0067	0.0059
Ag-	ND<0.0001	ND<0.0001	TR<0.0001	ND<0.0001	ND<0.0001
Ni-	0.0034	0.0032	0.0031	0.0044	0.0046
Zr-	0.021	0.025	0.025	0.039	0.028
Co-	0.0028	0.0023	0.0021	0.0024	0.0040
Cr-	0.035	0.013	0.027	0.054	0.032
Sr-	0.0020	0.0023	0.0021	0.0022	0.0019
Other	Nil	Nil	Nil	Nil	Nil

TR = Trace
ND = Not detectable

1
2
3

1
2
3

- (1) CHINO
- (2) BRAWLEY
- (3) VENTURA
- (4) FULLERTON
- (5) WALNUT

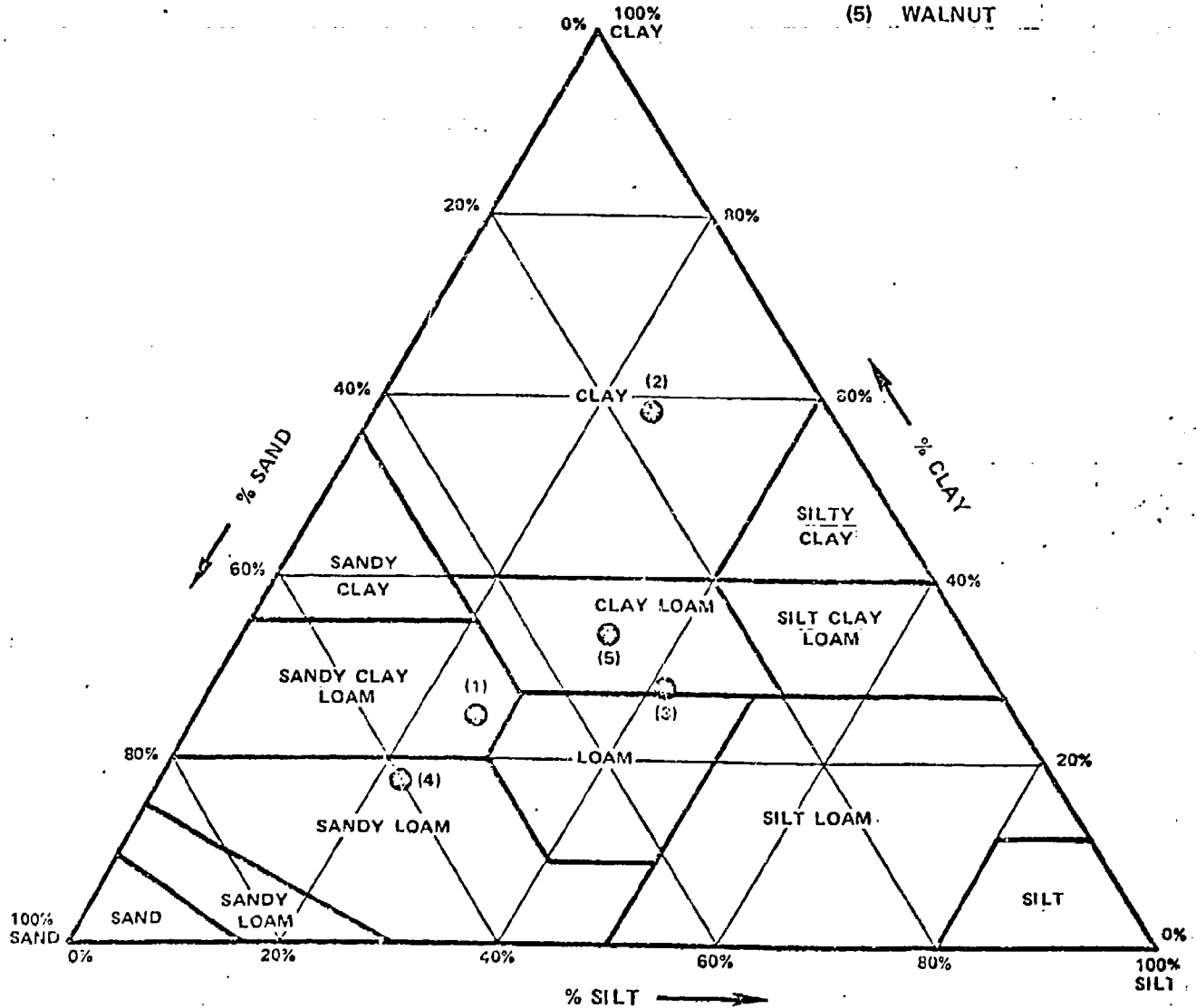

42
43
44

Figure 42. Textural Classification of Soils.

3.2.1.3 Experimental Design

There were two general methods of application of contamination to lysimeter soil to be investigated. The first, designated Group 1, consisted of applying a standard solution of DIMP in distilled water (20 ppm) to the surface of the soil and allowing it to percolate through the unit. Samples were taken of the ground water, drainage water, and soil at regular intervals for chemical analysis. The lysimeters were premoistened before the addition of the contaminant solution by adding distilled water at the top and allowing it to drain through the system until water appeared in the drainage pipe. This water was then allowed to drain out until flow ceased before beginning addition of the contaminated water.

The second method, Group 2, consisted of intimately mixing 20 ppm DIMP into the top 1 ft deep layer of test soils in a second group of five lysimeters and applying a 2-in. deep layer of distilled water to the soil surface at regular intervals. Samples of the ground water, drainage water, and soil were taken and treated as in Group 1. The chemical analysis for DIMP permitted observation of the progress of the chemical through the soil.

3.2.1.4 Sampling

Sampling of the lysimeter materials consisted of two general types: liquid and solid. The liquid (H_2O) samples were taken by draining the soil solution access tubes of their contents on a weekly basis. The tubes were stoppered in place by small (1/4 in. diameter) polyvinyl valves which, when opened, allowed the collected liquid to run into a 20cc screw capped scintillation vial (Kimble No. 74500). The sample tubes were positioned at an estimated 10° slope to allow liquid which collected in the ceramic cup to flow to the sampling valve. Samples from these tubes were small in volume, usually less than 10cc.

Concurrent with these access tube samples a sample of the drainage at the 60-in. depth was also taken. This was accomplished through a valve at the bottom center of the lysimeter. Drainage volumes of several liters were available and aliquots of these were taken for analysis.

The soil in the lysimeters was also sampled on a monthly basis by means of the coring tool described in Section 3.2.1.1. In practice the tool was inserted so as to retrieve a 6-in. deep core then retrieved and the approximately 6 in. by 1/2 in. core placed in a 4 oz glass jar and sealed. The tool was then returned to the same sampling hole and the next 6 in. increment of depth retrieved in like manner. This process was repeated until the entire

depth (60 in.) of the soil column had been sampled. One core sample, consisting of ten 6-in. increments plus one 1/8-in. surface sample, was taken from each lysimeter during each 1-month sampling period.

On completion of the sampling in a given location the sample hole was plugged by inserting into the full length of the hole a tight fitting 1/2 in. by 6 ft section of rigid polyvinyl pipe sealed on both ends.

3.2.2 Volatilization Studies (Radioactive).

3.2.2.1 Experimental System

The experimental arrangement used to determine volatilization loss took advantage of one available method for physically locating the subject chemicals in the test matrix, namely the use of radioactive tracer techniques with carbon-14 as the source of radioactivity. Samples of DIMP (Me - ^{14}C) and DCPD (X - ^{14}C) were synthesized by New England Nuclear Corporation for use with this technique.

The test procedure consisted of diluting the appropriate test chemical with nonradioactive DIMP and DCPD respectively and adding these solutions to samples of dry soil to a level of 20 ppm. This was accomplished by adding a weighed amount of radioactive liquid in a sealed, thin-walled analytical ampoule to a glass mixing jar containing the proper amount of dry soil, sealing the jar, and tumbling it for 7 to 10 hr. The ampoule is crushed by the initial rotation of the jar, and subsequent radioactivity measurements on different portions of the soil sample indicate that thorough mixing was achieved.

In the first experiment in this series the mixed samples were placed in 4 in. deep layers in a series of 25mm Pyrex test tubes. The tubes were set into gas trains as shown schematically in Figure 43. The actual apparatus is shown in the photographs in Figure 44. Dry air passed through Drierite columns and a 0.45 μ diameter Millipore filter was passed over the surface of the soil at 100 ml per min followed by bubbling into two methanol traps in series held in a dry ice/alcohol bath. At the completion of each of the various test periods samples of the soil were taken for analysis of remaining radioactivity.

The second set of experiments using these tracers was set up identically with the first with the following exception: The dry soil sample was moistened

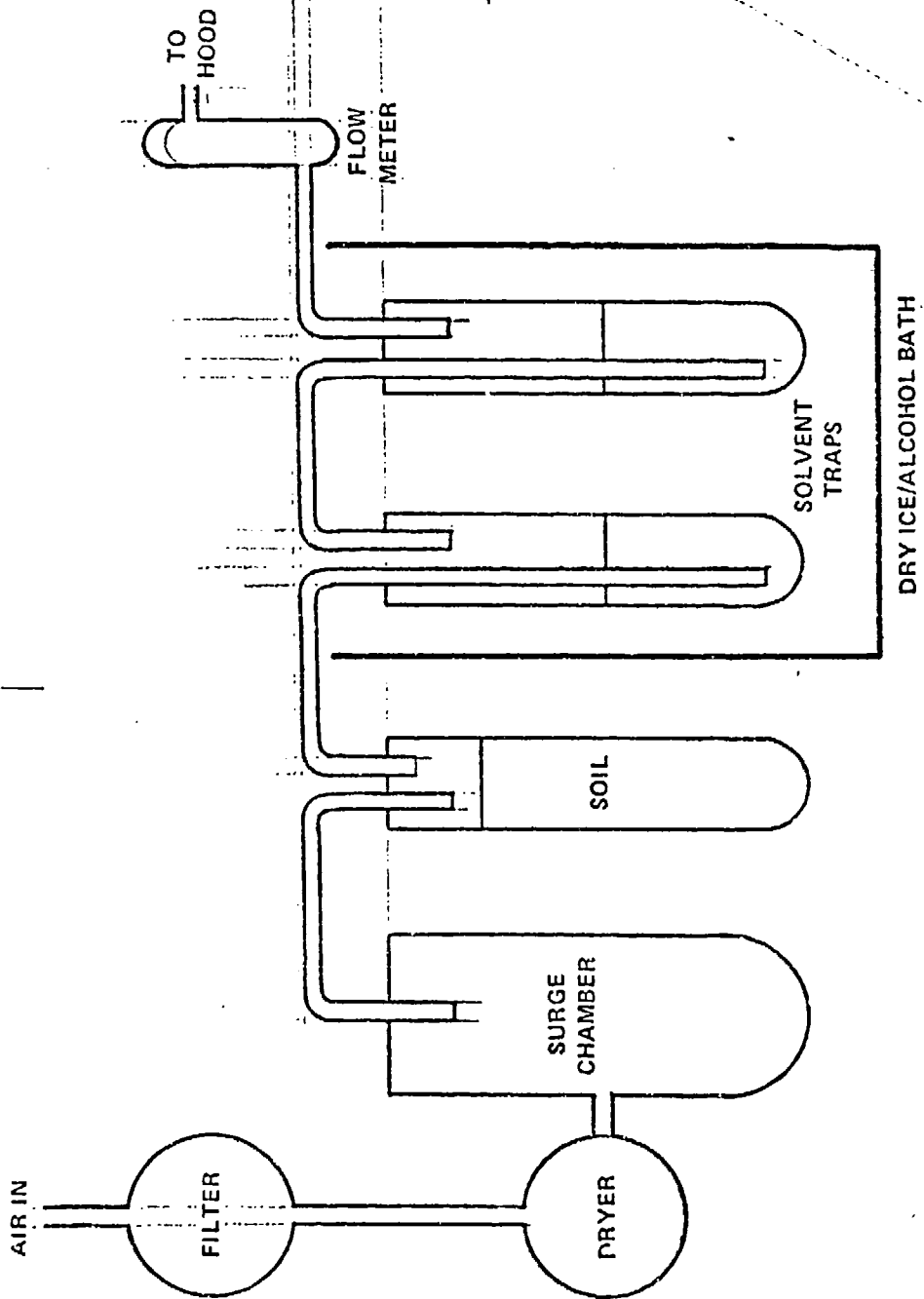

Figure 43. Laboratory Arrangement for Determining
Evaporative Loss of Chemicals from Soil.

1
2
3
4
5
6
7
8
9
10
11
12
13
14
15
16
17
18
19
20
21
22
23
24
25
26
27
28
29
30
31
32
33
34
35
36
37
38
39
40
41
42
43
44

1
2
3
4
5
6
7
8
9
10
11
12
13
14
15
16
17
18
19
20
21
22
23
24
25
26
27
28
29
30
31
32
33
34
35
36
37
38
39
40
41
42
43
44

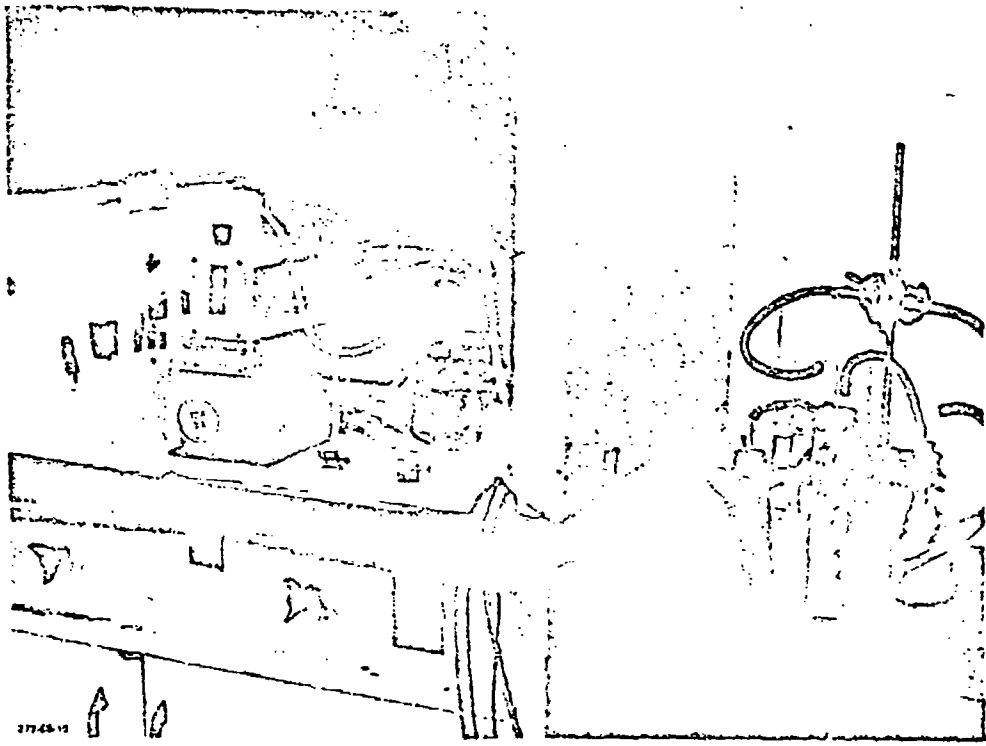

Figure 44. Laboratory Test Setup.

by the admixture of 20% of its weight of distilled water, and the test chambers were changed from 25mm Pyrex test tubes to 55mm Pyrex gas impinger bottles filled to a depth of 6 in. with the soil. All other operations were the same as with the first set.

3.2.2.2 Soil

The soil used in all of the radioactive tests consisted of Fullerton sandy loam topsoil that had been screened through a 1/4-in. mesh sieve and air-dried before use.

3.2.2.3 Sampling

At the completion of a given exposure period for the soil in the test tubes a tube was sacrificed and the soil contained therein divided into 1-in. increments of depth. These increments were kept in separate sample jars for submission to the radiation laboratory. The entire 1-in. increment was taken in each case. The effluent air downstream from the soil tubes was bubbled through solvent traps which contained methanol, in the DIMP train, and hexane, in the DCPD train. The total liquid contents of the bubble traps were also submitted for analysis.

3.2.3 Chemical Analysis

3.2.3.1 Soil and Water Samples.

The chemical analysis of the lysimeter soil and water samples followed the same general procedure as the analyses discussed in Section 2.2.4. Since DIMP was the only contaminant used in the lysimeter tests the direct introduction of sample solutions into the chromatograph was used. The sample solutions consisted of methanolic extracts of soil samples and ground water samples either used directly or diluted with distilled water if necessary.

3.2.3.2 Analysis of Radioactivity

The analysis of the radioactive samples consisted of determining the quantity of ¹⁴C present in a given sample. This was performed by New England

1	Nuclear Corporation, Boston, Massachusetts using the technique of sample	1
2	combustion, trapping, and scintillation counting of the released ¹⁴ C. The	2
3	quantity of radioactivity found was then calculated as percentage of radio-	3
4	activity initially placed in the sample.	4
5		5
6		6
7	3.3 RESULTS	7
8		8
9		9
10	3.3.1 Lysimeter Studies	10
11		11
12		12
13	3.3.1.1 Group 1	13
14		14
15	In the Group 1 experiments the contaminated irrigation water was added	15
16	weekly to the soil lysimeter by covering the surface with a 2-in. deep layer	16
17	of water (12,887cc) containing 20 ppm DIMP in solution. This rate of addi-	17
18	tion of material to the lysimeters was continued for 14 weeks at which time	18
19	the drainage had slowed considerably and the same addition was made on a	19
20	2-week cycle.	20
21		21
22	A set of analyses was run on the ground water samples from the lysimeters	22
23	just before each addition of a new charge of liquid. The soil core samples	23
24	were taken once during each monthly period and analyzed.	24
25		25
26	The amount of water collected at the bottom drainage port has been monitored	26
27	and related to the amount of water added to the top of the lysimeter. The	27
28	ratio of water added to water recovered is designated drainage ratio. Table 22	28
29	and Figure 45 illustrate the drainage ratios determined as a function of time	29
30	for the Group 1 lysimeters. Table 23 shows the DIMP content of the ground	30
31	water samples at the final sampling time.	31
32		32
33	Analysis of the soil core samples at the conclusion of the experiment was	33
34	run on four cores from each lysimeter.	34
35		35
36	Because of possible inhomogeneities and such phenomena as channeling	36
37	existing in the soil beds it was deemed advisable to collect multiple core	37
38	samples from the lysimeters for the terminal sampling run. Averaging the	38
39	values for each increment of depth, which should be representative of the	39
40	real DIMP content, yielded the values in Table 24.	40
41		41
42	The individual values from which the averages in Table 24 were derived can	42
43	be seen in Table B-1 and Figures B-1 through B-5 of Appendix B.	43
44		44

Table 22. Lysimeter Drainage Ratios, Group 1, a

Lysimeter Age (days)	Chino	Brawley	Ventura	Fullerton	Walnut	Average
10.5	1.04	0.93	0.91	1.00	0.88	0.95
26	0.59	0.62	0.57	0.49	0.64	0.58
38.5	0.58	0.57	0.54	0.55	0.58	0.57
52.5	0.47	0.60	0.60	0.60	0.60	0.58
66.5	0.73	0.86	0.90	c	0.83	0.79
80.5	0.75	0.81	0.74	c	0.73	0.78
93.5	0.57	0.78	0.61	c	0.66	0.67
112	0.64	0.65	0.62	0.43	0.54	0.58
140	0.52	0.75	0.62	0.42	0.41	0.55
168	0.54	0.42	0.55	0.40	0.40	0.46
195	0.41	0.57	0.63	0.51	0.49	0.52
216 ^b	0.26 ^b	0.07 ^b	0.43 ^b	0.28 ^b	0.33 ^b	0.27
237	0.44	0.44	0.55	0.31	0.51	0.45
265	0.47	0.21	0.59	0.26	0.52	0.41
293	0.66	0.59	0.75	0.41	0.58	0.60
321	0.37	0.35	0.61	0.29	0.58	0.44
349	0.47	0.34	0.64	0.24	0.45	0.43
377	0.59	0.41	0.69	0.24	0.43	0.47
419	0.45	0.39	0.70	0.21	0.39	0.43

^a Averages of successive pairs of data points.

^b Single value, not average.

^c Do not fit sampling sequence.

1
2
3
4
5
6
7
8
9
10
11
12
13
14
15
16
17
18
19
20
21
22
23
24
25
26
27
28
29
30
31
32
33
34
35
36
37
38
39
40
41
42
43
44
45
46
47
48
49
50
51
52
53
54
55
56
57
58
59
60
61
62
63
64
65
66
67
68
69
70
71
72
73
74
75
76
77
78
79
80
81
82
83
84
85
86
87
88
89
90
91
92
93
94
95
96
97
98
99
100

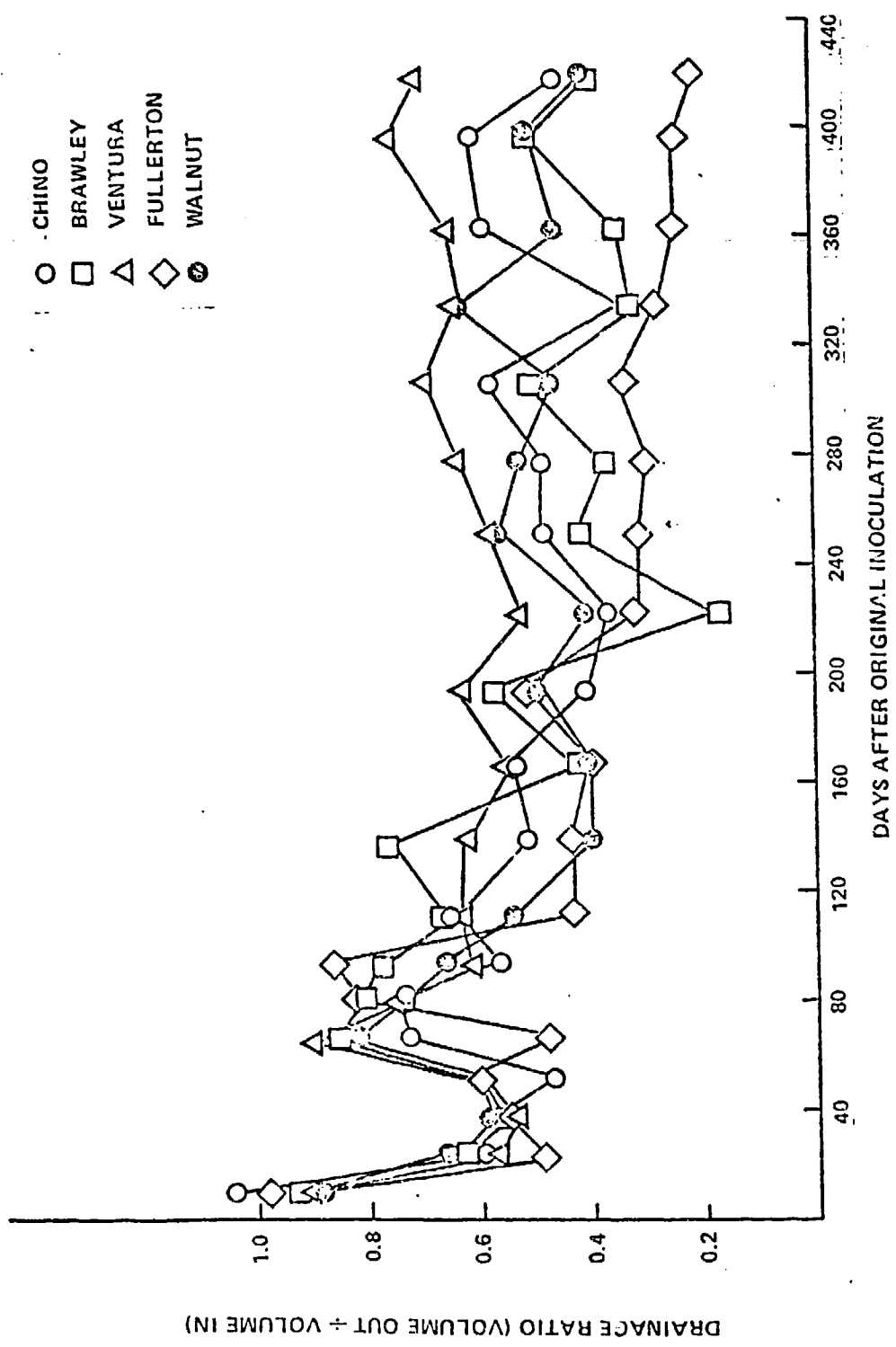

Figure 45. Drainage Ratios of Various Soils in Full-Scale Lysimeter Tests, Group 1.

Table 23. DIMP Content of Tensiometer Water Samples
 (Group 1) at 405 Days (ppm)

Depth (in.)	Ventura	Chino	Fullerton	Walnut	Brawley
6	*	17.1	28.3	26.9	27.7
18	6.7	16.5	18.0	7.5	26.0
30	4.9	23.2	26.4	20.1	16.7
42	8.6	17.5	25.3	14.5	17.1
54	18.1	17.7	18.7	12.3	13.7
60	14.3	18.4	15.6	18.7	15.5
* No sample					

The total DIMP content was calculated assuming that the 6-in. core for each sampling period was representative of the corresponding lysimeter cross section. The ratio between lysimeter cross section volume and sample core volume is $\frac{38.2298 \text{ liter}}{0.03878 \text{ liter}} = 985.81$. This means that the lysimeter cross section should contain 985.81 times the DIMP quantity determined in the entire core sample.

During the course of the 426 day experiment for Group 1, 9.5349 gm of DIMP was added to the surface of each lysimeter. Calculation of the DIMP content of the lysimeters at the conclusion of the experiment resulted in the data shown in Table B-2 of Appendix B.

The weight of DIMP in drain water was calculated by determining chromatographically the concentration of DIMP in the drain water and multiplying it by the volume thereof for each drainage increment. Summing the drain recovery and the soil recovery gives the total DIMP recovery shown in Table 25. These data are illustrated in Figure B-6 of Appendix B.

Table 24. Average DIMP Content of Soil Samples (ppm)
After 426 Days, Group 1.

Depth (in.)	Ventura	Chino	Fullerton	Walnut	Brawley
0 (surface)	28.4	28.9	23.6	33.3	18.4
0 - 6	6.5	7.4	8.7	9.0	6.5 ^a
6 - 12	4.8	7.1	7.1	8.2	8.6 ^a
12 - 18	2.5	5.3	6.1	7.2	7.0
18 - 24	3.3	5.2	5.9	6.0	7.6
24 - 30	2.4	4.9	5.7	6.5	6.9
30 - 36	2.7	3.5	8.3	7.5	6.6
36 - 42	4.5	4.1	5.8	6.6	5.7
42 - 48	2.9	3.0	6.1	8.8	6.0
48 - 54	2.8	3.5	6.4	7.8	5.0
54 - 60	3.1	6.8 ^a	4.9	6.3	5.8

^a Group contains some samples with no detectable DIMP; i. e., < 0.1 ppm.

Table 25. Material Balance, Lysimeter
Group -- 426 Days.*

Sample	DIMP in Drain Water (gm)	Weight of DIMP in Soil (gm)	Total Weight of DIMP Recovered (gm)	DIMP Recovered (%)
Chino	1.66	2.88	4.54	47.6
Brawley	3.06	2.02	5.08	53.3
Ventura	2.42	1.67	4.09	42.9
Fullerton	0.84	2.62	3.46	36.3
Walnut	2.54	3.04	5.58	58.5
Average	2.10	2.45	4.55	47.7

*9.5349 gm DIMP added

The drainage solutions appeared to have reached an equilibrium concentration by the end of the study. The average DIMP concentrations for the pairs of drainage increments in Group 1 are shown in Table 26.

The amount of water present in the soil at sampling time was determined by taking one half of the weight of the core sample and drying it to constant weight in a 110°C forced air oven. Representative data from this type of analysis for Group 1 are shown in Table 27.

A comparison of these data with other similar data from Group 1 and Group 2 can be seen in Appendix B, Figure B-7.

3.3.1.2 Group 2

Similar types of data were generated in the Group 2 lysimeter experiments in which DIMP (20 ppm) was intimately mixed with the top 1-ft layer of soil and subsequently subjected to regular irrigation with 2-in. deep layers of distilled water which were allowed to percolate down through the soil.

Table 26. DIMP Concentration in 60-in. Drain Samples, Group 1.

Duration of Irrigation (days)	Soil Designation				
	Walnut	Fullerton	Ventura	Brawley	Chino
30	a	0.6	2.2	0.3	a
51	a	a	2.0	0.8	a
58	a	0.4	1.9	0.5	a
66	0.2	0.5	2.0	0.4	a
73	0.2	0.7	3.3	0.1	0.2
86	0.5	0.7	5.6	0.5	0.8
93	0.3	0.9	3.2	0.2	0.6
100	0.5	0.8	1.9	0.5	0.5
107	0.7	0.6	3.1	1.0	0.7
112	1.1	0.7	3.2	1.4	1.3
119	1.4	0.6	3.3	1.6	1.3
128	2.5	1.2	3.3	4.5	2.7
142	1.9	1.1	3.8	2.2	2.4
156	3.1	2.3	3.7	3.9	5.7
185	1.9	1.6	4.6	5.6	4.5
199	4.2	3.7	6.8	4.2	4.3
213	5.3	6.9	9.6	8.4	3.4
227	8.4	7.9	21.5	18.3	15.1
240	11.3	7.7	14.1	12.0	11.5
254	33.9	11.0	23.4	18.0	12.3
282	11.7	10.4	15.2	17.0	12.3
312	15.4	10.1	15.4	10.5	14.1
335	23.9	17.1	19.9	21.4	20.2
365	21.1	15.0	18.9	15.8	20.2
405	18.7	15.6	14.3	15.5	18.4
419	32.1	24.8	13.9	16.9	19.6
^a Less than 0.1 ppm					

Table 27. Percent Loss on Drying of Soil from East Lysimeters, Group 1 -- 207 Days from Original Inoculation.*

Sample Depth (in.)	Ventura	Chino	Fullerton	Walnut	Brawley	Mean
1/8 - 6	10.25	9.63	10.31	11.75	12.18	10.82
6 - 12	12.04	14.45	11.72	13.58	16.49	13.66
12 - 18	5.47**	14.84	12.89	15.12	17.56	15.10
18 - 24	2.68**	14.21	11.52	17.04	18.79	15.39
24 - 30	13.07	14.73	11.17	17.79	17.82	14.92
30 - 36	14.32	15.16	12.42	16.50	12.88	14.26
36 - 42	15.52	15.73	15.96	14.43	19.70	16.27
42 - 48	17.01	15.47	16.97	13.01	14.08	15.31
48 - 54	16.23	15.37	17.99	17.17	21.97	17.75
54 - 60	15.24	17.88	19.97	19.32	22.98	19.08

* After 2-week drainage.

** Sample jar left open before determination.

The quantity of DIMP varied slightly for the different types of soil because of the slight variation in their apparent density. These quantities are as follows:

Soil Type	Quantity of DIMP Added (gm)
Chino, scl	5.60
Brawley, sc	5.22
Ventura, cl	5.98
Fullerton, sl	5.22
Walnut, cl	5.35

1 The irrigation was carried out at the rate of one time per week for the first
 2 six weeks and due to changes in the drainage rate was changed to one time
 3 per two weeks for the remainder of the experiment.

4 Analysis of the ground water samples showed the presence of DIMP ultimately
 5 at every level in the lysimeters in two cases and at almost every level in
 6 the other three. The terminal data after 315 days of irrigation are shown
 7 in Table 28.

8 Multipoint soil samples were taken as in Group 1 (Section 3.3.1.1) at the
 9 final sampling period. Analytical results for these samples and the individual
 10 data points from which they are derived are in Table B-3, Appendix B.

11
 12
 13
 14
 15 Table 28. DIMP Content of Ground Water Samples
 16 at 315 Days (ppm), Group 2.

Depth (in.)	Ventura	Chino	Fullerton	Walnut	Brawley
6	*	*	*	*	*
13	*	13.0	*	*	2.9
30	9.3	46.2	21.8	12.2	58.6
42	72.2	**	33.7	15.9	18.2
54	39.5	24.6	31.1	61.5	*
60	*	2.2	45.4	*	*
* < 0.1 ppm					
** No sample					

17
 18
 19
 20
 21
 22
 23
 24
 25
 26
 27
 28
 29
 30
 31
 32
 33
 34
 35
 36 Drainage ratios were determined on the Group 2 lysimeters in the same
 37 manner as described previously. Table 29 and Figure 46 present the data
 38 from these determinations.

39
 40
 41
 42
 43
 44 Material balance figures for DIMP recovery in the Group 2 experiments are
 shown in Tables 30 and 31 and are based upon the amount of DIMP determined
 in the soil core samples since essentially none was lost through drainage.

Table 29. Drainage Ratios, Group 2.

Lysimeter Age (Days)	Chino	Brawley	Ventura	Fullerton	Walnut	Average
7	0.03	0.12	0.13	0.07	0.09	0.09
14	0.01	0.04	0.11	0.03	0.00	0.04
21	0.02	0.00	0.00	0.13	0.08	0.05
28	0.20	0.02	0.11	0.35	0.47	0.23
35	0.30	0.18	0.32	0.44	0.48	0.34
42	0.31	0.33	0.41	0.41	0.56	0.40
56	0.72	0.70	1.03	0.90	0.91	0.85
70	0.35	0.34	0.47	0.63	0.44	0.45
84	0.10	0.05	0.21	0.30	0.24	0.18
98	0.11	0.10	0.23	0.34	0.35	0.23
112	0.15	0.13	0.22	0.37	0.35	0.24
126	0.13	0.24	0.23	0.33	0.26	0.24
140	0.07	0.15	0.17	0.30	0.22	0.18
154	0.18	0.09	0.17	0.24	0.28	0.19
168	0.28	0.26	0.41	0.85	0.64	0.49
182	0.28	0.20	0.34	0.32	0.46	0.32
196	0.14	0.12	0.23	0.32	0.45	0.25
210	0.18	0.11	0.40	0.27	0.37	0.27
224	0.24	0.08	0.16	0.23	0.41	0.22
238	0.24	0.15	0.29	0.32	0.47	0.29
252	0.15	0.09	0.22	0.24	0.36	0.21
280	0.37	0.35	0.50	0.51	0.81	0.51
294	0.14	0.15	0.22	0.29	0.55	0.27
308	0.20	0.16	0.29	0.36	0.38	0.28
322	0.14	0.09	0.25	0.35	0.38	0.24

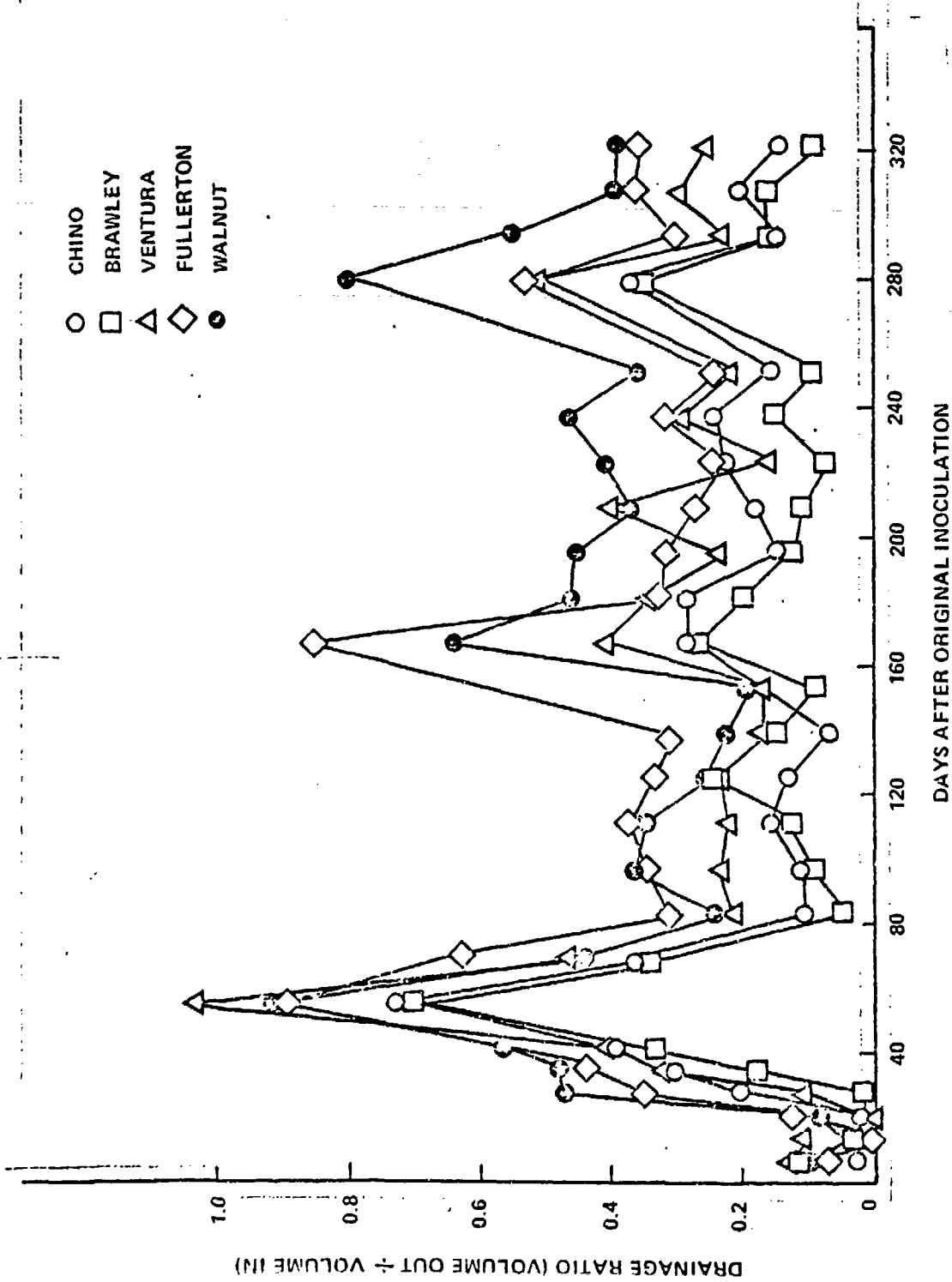

Figure 46. Drainage Ratios of Various Soils in Full-Scale Lysimeter Tests, Group 2.

Table 30. Average DIMP Content of Soil Samples (ppm)
After 322 Days, Group 2.

Depth (in.)	Ventura	Chino	Fullerton	Walnut	Brawley
0 (surface)	b	b	b	b	b
0 - 6	b	b	b	b	b
6 - 12	b	b	b	b	b
12 - 18	b	b	b	b	b
18 - 24	b	b	b	b	b
24 - 30	0.9 ^a	2.3 ^a	b	b	1.6 ^a
30 - 36	3.5 ^a	4.0 ^a	b	b	14.4 ^a
36 - 42	9.4	9.5	9.7	b	17.0
42 - 48	10.7	11.1	12.8	3.0 ^a	9.1
48 - 54	11.7	7.4	11.0	6.8	4.5
54 - 60	7.1	3.0 ^a	14.0	9.8	2.8 ^a

^aGroup contains some samples with no detectable DIMP;
i. e. < 0.1 ppm.

^b 0.1 ppm.

Table 31. Material Balance, Lysimeter
 Group 2, 322 Days.

Soil Type	Weight of DIMP Recovered (gm)	DIMP Recovered (%)
Chino	2.10	37.5
Brawley	2.41	46.2
Ventura	2.53	42.3
Fullerton	2.00	38.3
Walnut	0.79	14.8

Data from the individual core samples used in this material balance determination are shown in Table B-4, Appendix B.

The amount of water present in the soil samples was determined on Group 2 samples. Table 32 shows data derived in the same manner as that for Group 1.

Figure B-7 in Appendix B compares these data with other similar data.

3.3.2 Volatilization Studies (Radioactive Studies (Radioactive)).

Results of analyses of the soil and solvent samples removed from the radioactive tracer experiments described in Section 3.2.2 are presented in Tables 33 through 36. The total 1-in. deep sections of soil were analyzed individually. The figures labeled "total" are summations of all of the component fractions for a given sample.

3.4 DISCUSSION

3.4.1 DIMP

The ¹⁴C tracer experiments indicated that DIMP mixed with wet or dry Fullerton sandy loam was not lost to the atmosphere by volatilization in

Table 32. Percent Moisture in Soil of Group 2 Lysimeters
 34 Days from Original Inoculation.*

Sample Depth (in.)	Ventura	Chino	Fullerton	Walnut	Brawley	Mean
1/8 - 6	5.95	13.05	11.93	14.00	14.51	11.89
6 - 12	7.28	15.30	14.02	15.88	17.99	14.09
12 - 18	16.40	17.00	12.53	17.30	19.96	16.64
18 - 24	16.52	16.79	14.28	19.30	19.01	17.18
24 - 30	17.36	16.79	15.68	17.42	20.55	17.56
30 - 36	17.84	17.17	17.03	20.76	22.36	19.03
36 - 42	18.70	17.77	18.59	21.76	21.97	19.76
42 - 48	20.09	18.35	20.10	24.64	21.97	21.03
48 - 54	21.24	19.15	19.80	25.60	21.60	21.48
54 - 60	19.12	19.87	20.75	20.70	21.41	20.37
* After 2-week drainage.						

significant quantities. This finding will influence conclusions based on the data from the lysimeter experiments. In the case of the Group 1 tests in which an average of 55% of the irrigation solution added was recovered, the average recovery of DIMP was approximately 48%. In the case of Group 2 tests in which the average recovery of the irrigation water was 28% the average recovery of DIMP was approximately 36%.

Since the lysimeter soils in both Groups 1 and 2 were saturated with water before the first addition of DIMP it can be assumed that the most probable mechanism of surface water loss is vaporization. This conclusion is compatible with literature values* for rate of evaporation of water from soil surfaces.

* Audus, L. J. The Physiology and Biochemistry of Herbicides. New York: Academic Press (1964), 1. 133.

Table 33. Recovery of Radioactive Tracers from DIMP Experiments in Fullerton Soil (Dry)

Sample No.	Description	Sample Weight (gm)	Radioactivity		Stock Radio-activity Found (%)	Airflow Time at 100 ml/min at 75°F (hr)
			Calculated (μCi)	Found (μCi/gm)		
1	Working DIMP soil	4.0786	17.39	3.35×10^{-1}	100	14
2	0-1-in. soil DIMP	12.0783	17.39	2.57×10^{-1}		
3	1-2-in. soil DIMP	9.8508	17.39	3.01		
4	2-3-in. soil DIMP	14.5075	17.39	3.05×10^{-1}		
5	3-4-in. soil DIMP	15.4770	17.39	5.03		
6	14-hr DIMP trap (1)	15.8061	17.39	7.89×10^{-2}		
7	14-hr DIMP trap (2)	18.8929	17.39	4.32×10^{-4}		
	14-hr total		17.39	15.64	89.9	
8	0-1-in. soil DIMP	13.9275	16.99	4.14		
9	1-2 in. soil DIMP	15.3755	16.99	5.00	95.3	231
10	2-3-in. soil DIMP	10.3126	16.99	3.20		
11	3-4-in. soil DIMP	11.0975	16.99	3.82		
12	231-hr DIMP trap	7.5540	16.99	0.03		
	231-hr total		16.99	16.19		

1
2
3
4
5
6
7
8
9
10
11
12
13
14
15
16
17
18
19
20
21
22
23
24
25
26
27
28
29
30
31
32
33
34
35
36
37
38
39
40
41
42
43
44
45
46
47
48
49
50

Table 34. Recovery of Radioactive Tracers from DCPD Experiments in Fullerton Soil (Dry).

Sample No.	Description	Sample Weight (gm)	Radioactivity		Stock Radioactivity Found (%)	Airflow Time at 100 ml/min at 75°F (hr)
			Calculated (μCi)	Found ($\mu\text{Ci/gm}$)		
1	Working DCPD soil (1)	2.7980	0.64	1.27×10^{-2}	100	8
2	0-1-in. soil DCPD	13.6043	0.64	1.47×10^{-2}		
3	1-2-in. soil DCPD	12.6218	0.64	1.19×10^{-2}		
4	2-3-in. soil DCPD	13.1804	0.64	1.06×10^{-2}		
5	3-4-in. soil DCPD	11.1260	0.64	9.89×10^{-3}		
6	8 hr DCPD trap (1)	13.6172	0.64	7.34×10^{-4}		
7	8 hr DCPD trap (2)	11.6143	0.64	8.61×10^{-6}		
	8-hr total		0.64	0.61	95.3	
8	0-1-in. soil DCPD	13.3916	0.67	1.49×10^{-2}		
9	1-2-in. soil DCPD	9.3248	0.67	1.50×10^{-2}	50	
10	2-3-in. soil DCPD	13.5947	0.67	1.18×10^{-2}		
11	3-4-in. soil DCPD	16.5598	0.67	1.03×10^{-2}		
12	50 hr DCPD trap	1.3390	0.67	7.47×10^{-3}		
	50-hr total		0.67	0.68		
13	0-1-in. soil DCPD	11.9831	0.68	0.18	101.5	267
14	1-2-in. soil DCPD	13.1534	0.68	0.18		
15	2-3-in. soil DCPD	12.3646	0.68	0.14		
16	3-4-in. soil DCPD	16.2240	0.68	0.14		
17	267-hr DCPD trap	12.4104	0.68	0.01		
	267-hr total		0.68	0.65		

Table 35. Recovery of Radioactive Tracers from DIMP Experiments in Fullerton Soil (Wet).

Sample No.	Description	Sample Weight (gm)	Radioactivity		Stock Radio-activity Found (%)	Airflow Time at 100 ml/min at 75°F (hr)	
			Calculated (μCi)	Found			
				(μCi/gm)			(μCi)
1	Working DIMP soil		126	2.79×10^{-1}		154	
2	0-1-in. soil DIMP	41.3	126	1.95×10^{-1}	8.05		
3	1-2-in. soil DIMP	70.9	126	2.14×10^{-1}	15.17		
4	2-3-in. soil DIMP	81.6	126	2.21×10^{-1}	18.03		
6	3-4-in. soil DIMP	80.4	126	2.18×10^{-1}	17.53		
7	4-5-in. soil DIMP	80.9	126	2.24×10^{-1}	18.12		
	5-6-in. soil DIMP	96.6	126	2.25×10^{-1}	21.74		
	154-hr total		126		98.64	78.3	

1
2
3
4
5
6
7
8
9
10
11
12
13
14
15
16
17
18
19
20
21
22
23
24
25
26
27
28
29
30
31
32
33
34
35
36
37
38
39
40
41
42
43
44

Table 36. Recovery of Radioactive Tracers from DCPD Experiments in Full-ton Soil (Wet).

Sample No.	Description	Sample Weight (gm)	Radioactivity		Stock Radio-activity Found (%)	Airflow Time at 100 ml/min at 75°F (hr)
			Calculated (μCi)	Found (μCi/gm)		
1	Working DCPD soil			9.90×10^{-3}		154
2	0-1-in. soil DCPD	33.3	3.62	5.54×10^{-3}	0.18	
3	1-2-in. soil DCPD	65.8	3.62	6.03×10^{-3}	0.40	
4	2-3-in. soil DCPD	51.8	3.62	5.94×10^{-3}	0.31	
5	3-4-in. soil DCPD	63.5	3.62	6.65×10^{-3}	0.42	
6	4-5-in. soil DCPD	54.2	3.62	5.93×10^{-3}	0.32	
7	5-6-in. soil DCPD	96.7	3.62	6.24×10^{-3}	0.60	
	154-hr total		3.62		2.23	61.6

1
2
3
4
5
6
7
8
9
10
11
12
13
14
15
16
17
18
19
20
21
22
23
24
25
26
27
28
29
30
31
32
33
34
35
36
37
38
39
40
41
42
43
44

In Group 1 it appeared that the surface layers of the soils accumulated the DIMP in a concentrated band and allowed it to be stripped off and distributed throughout the soil profile in a more dilute condition. In Group 2 it appeared that the DIMP which was dispersed through the top 1-ft layer of soil never achieved a narrow concentrated band but, in all cases, moved down through the lysimeter with the added water in a broadening band condition.

The soils used in this study were selected to give a range of particle sizes and physical and chemical characteristics which might be encountered in typical agricultural areas. For instance Brawley clay has the greatest quantity of small particles. It would be expected that, all else being equal, a surface area dependent absorption phenomenon would lead to a greater holdup of the DIMP in the Brawley soil and the least amount in the Fullerton soil which was highest in coarse particles. Such a direct implication does not hold for this phenomenon and a much greater study in depth of the soil characteristics and their interactions with the characteristics of the contaminant compounds would be needed before definitive relationships could be generated.

Binding of DIMP to dry soil versus wet soil appears to have some difference in effect. Group 1 tests applied a solution of DIMP in water to a previously moistened soil column. Group 2 mixed DIMP with a layer of dry soil which was then leached into a previously moistened soil column. The DIMP from the Group 1 lysimeters emerged from the drain in detectable quantities in less than 30 days while the Group 2 DIMP emergence required approximately 150 days.

5.4.2 DCPD

Lack of a suitable sensitive chemical analysis procedure for DCPD in the types of samples generated in this program led to its exclusion from the lysimeter study. As in the case of DIMP, however, the ¹⁴C tracer study indicated that the major portion of DCPD incorporated into dry or wet soil matrixes was not volatilized into air passing over the soil surface.

This type of experiment does not confirm the existence of the original compound (i. e., DCPD) in the soil but only the ¹⁴C. It is possible then that the original compound is stable in the soil, that it has decomposed or polymerized to other non-vaporizable species, or that it has become relatively irreversibly bound to the soil.

Simple vaporization of the compound or significant decomposition into volatile products (e. g., CO₂) does not appear to be the case.

Section 4

CONCLUSIONS

4.1 DIMP

4.1.1 Phytotoxicity

High concentrations of DIMP (100 ppm and greater) in hydroponic nutrient media cause tissue damage to various types of agricultural plants. Tissue damage includes foliar necrosis evidenced by browning and curling reactions and dwarfing. Low concentrations in the same system (10 ppm or less) have no visible effect or in some cases cause an enhancement of growth.

Under conditions of irrigation with DIMP contaminated water in soil culture of sugar beets, carrots, beans, wheat, and alfalfa the effect level for foliar damage in mature plants was placed at approximately 50 ppm.

4.1.2 Bioconcentration

Bioconcentration of DIMP within the living plants was demonstrated by chemical analyses of plant tissues from both soil and hydroponic culture. For most plants the concentration appeared to be centered in the leaves. The edible portion of the plants normally consumed by humans, such as radish, carrot and beet root, bean pods, and tomato fruit, display little tendency to accumulate the DIMP and thus would not function as concentrators in the human food chain. Other portions, such as wheat, fescue, beet and corn leaves, as well as other leaves which appear to concentrate the DIMP in their tissues if used for animal fodder, could be a route of entry into the food chain. The significance to the human food chain of this intrusion is dependent upon the ultimate fate or location of the compound in the animal organism.

The mechanism by which the plant leaves accomplish their concentration of DIMP is not explained. The DIMP in solution appears to follow the general water movement in the plants; i. e., the roots and stem being transport media and the added transpiration of water by the leaves having an effect on the deposition of contaminant compound in their tissues.

4.1.3 Environmental Fate in Soil

Radioactive tracer experiments have shown that DIMP, when mixed with wet or dry soils, is not lost to the atmosphere by vaporization to an appreciable degree. Little of the radioactivity in DIMP (Me - ¹⁴C) is lost to moving airstreams in soil retention experiments.

Soil lysimeter studies have shown that for a range of soil types DIMP chronically applied in irrigation water accumulates in the soil surface and is ultimately distributed throughout the soil profile in a dilute condition. Approximately one half of the DIMP applied under these conditions was recovered as was approximately one half of the added irrigation water.

Although it was indicated by the radioactive tracer experiments that DIMP mixed with soil does not have a significant evaporation rate, that does not rule out the possible relatively small amounts of evaporation of DIMP which are dissolved in water standing on the soil surface. Experimental data on the vaporization characteristics of dilute solutions of DIMP in water are required before definitive statements concerning mass balance in the lysimeter tests are possible, but if one can assume the validity of the vaporization phenomenon proposed above, the mass recovery data from these tests are reasonable.

On the other hand, of the DIMP which was intimately mixed with soil before leaching with water, less than one half was recovered (36%). The amount of water recovered also was comparable (28%). Without additional experimental data it would be premature to propose mechanisms to explain these material balance figures. Data relating to DIMP solubility rates in water, chemical decomposition, and characteristics of binding to soil would all affect such proposals.

Downward movement of the DIMP applied to the soil surface layer and leached with distilled water has been demonstrated. DIMP, originally at 20 ppm in a 1-ft surface layer, was not detectable upon termination of the irrigation experiments nearer to the surface than 2 ft in several cases. In the remaining cases the DIMP was undetectable to greater depths. These results indicate that DIMP contaminant applied to soil definitely moves through the soil with irrigation water flow.

The procedures used in the analysis of the DIMP samples appear to be reasonably effective. Soil and plant extracts and direct water samples subjected to gas-liquid chromatography and alkaline flame ionization detection can routinely detect > 0.1 ppm added DIMP in the sample matrix. Repetitive reextraction of samples produces no detectable added DIMP. The chief

1 advantage of this analytical technique is its sensitivity to phosphorous com- 1
2 pounds. One conceivable disadvantage is that without much more elaborate 2
3 apparatus (i. e., mass spectrometry) it can only be used for the specific 3
4 compounds whose chromatographic characteristics are known. In terms 4
5 of this study it is useful for determining DIMP only as the DIMP molecule 5
6 and not its unknown or low concentration decomposition products. 6

7
8
9 4.2 DCPD 9

10
11
12 4.2.1 Phytotoxicity 12

13
14 Sufficiently large applications of DCPD (1000 ppm) to hydroponic nutrient 14
15 baths produced stunting in most plants. DCPD-water mixtures applied to the 15
16 soil surface in soil growth tests demonstrated no significant phytotoxic effect. 16
17 The lack of transport of the DCPD throughout the system especially to the 17
18 plant roots, because of its low solubility in water, is probably a major reason 18
19 for this. 19

20
21 The hydroponically grown plants survived the DCPD in a relatively unscathed 21
22 condition because of the experimental arrangement in which the plant roots 22
23 were continually submerged in the nutrient solution and air was supplied by 23
24 bubbling it into the solution. The roots were never lifted through the film 24
25 of DCPD which covered the surface of the baths. 25

26
27 Tests of DCPD were run without solution aids in an attempt to duplicate 27
28 simple, natural conditions. If the phytotoxic effect of DCPD per se is to be 28
29 examined, topical application, injection, or the use of innocuous surfactants 29
30 should be considered. 30

31
32
33 4.2.2 Bioconcentration 33

34
35
36 Since 100 ppm DCPD was the limiting concentration for the analytical system 36
37 without subjecting the samples to a concentration step, and since no DCPD 37
38 was detected in any of the tissue samples tested it must be concluded that 38
39 there was no bioconcentration, as defined above, of DCPD in the 100 and 39
40 1000 ppm hydroponic plants. This may not be a totally valid conclusion in 40
41 this case because there is no information available as to the actual contami- 41
42 nation application level seen by the plant roots. 42

DCPD when applied to plant soil environments in the manner used in these experiments will have no discernable phytotoxic effect.

4.2.3 Environmental Fate in Soil

The data from this study regarding the environmental fate of DCPD in soil are restricted to that from the radioactive (^{14}C) tracer study. These data indicate that the major portion of DCPD radioactivity from test samples of 20 ppm DCPD from dry or moist soil appears to remain fixed in the soil under the experimental conditions. This experiment was designed to observe the stability of the compound in soil under a moving airstream. To generate data as to movement of the DCPD under a condition of irrigation will require additional experimental activity.

1
2
3
4
5
6
7
8
9
10
11
12
13
14
15
16
17
18
19
20
21
22
23
24
25
26
27
28
29
30
31
32
33
34
35
36
37
38
39
40
41
42
43
44

1
2
3
4
5
6
7
8
9
10
11
12
13
14
15
16
17
18
19
20
21
22
23
24
25
26
27
28
29
30
31
32
33
34
35
36
37
38
39
40
41
42
43
44

1
2
3
4
5
6
7
8
9
10
11
12
13
14
15
16
17
18
19
20
21
22
23
24
25
26
27
28
29
30
31
32
33
34
35
36
37
38
39
40
41
42
43
44

Appendix A

DIMP AND DCPD CONCENTRATIONS IN PLANTS

Table A-1. Yield of Various Plants Exposed to DIMP or DCPD During Growth Period. (Sheet 1 of 5)

Average Weight (gm)					Number of Plants in Average	Contaminant Type	Concentration of Contaminant in H ₂ O (ppm)
Leaf	Stem	Root	Edible Fruit	Total Plant			
BEAN ^a							
2.59	5.84	0.40	5.33	14.64	8	Negative control	0
7.24	9.97	0.58	8.24	20.14	6	DCPD	1
3.75	6.08	0.35	10.28	21.59	10	DCPD	8
10.85	16.90	0.83	13.19	43.87	5	DCPD	20
6.13	7.99	0.51	14.00	29.88	2	Positive control	1
17.49	16.73	0.69	12.39	49.50	1	Positive control	8
14.44	19.77	1.08	0.96	36.83	1	Positive control	20
3.34	11.11	0.64	12.06	27.56	7	DIMP	1
3.83	12.65	0.58	9.62	26.94	5	DIMP	8
12.85	20.13	0.98	6.85	41.99	5	DIMP	20
7.74	27.66	1.67	16.68	54.28	1	Positive control	1
10.89	20.06	1.18	9.24	42.19	1	Positive control	8
5.81	12.15	0.71	11.21	30.19	2	Positive control	20

1
2
3
4
5
6
7
8
9
10
11
12
13
14
15
16
17
18
19
20
21
22
23
24
25
26
27
28
29
30
31
32
33
34
35
36
37
38
39
40
41
42
43
44

Table A-1. Yield of Various Plants Exposed to DIMP or DCPD During Growth Period. (Sheet 2 of 5)

Average Weight (gm)				Number of Plants in Average	Contaminant Type	Concentration of Contaminant in H ₂ O (ppm)	
Leaf	Stem	Root	Edible Fruit				Total Plant
WHEAT ^a							
0.68	1.00	0.49	1.27	4.37	18	Negative control	0
0.68	1.40	0.48	1.15	5.45	24	DCPD	1
1.41	2.07	1.67	2.75	10.73	12	DCPD	8
1.01	1.52	0.83	1.39	6.72	16	DCPD	20
0.67	0.67	0.52	1.40	5.25	3	Positive control	1
1.10	1.29	0.91	2.65	7.50	3	Positive control	8
0.84	1.43	0.65	1.37	5.71	4	Positive control	20
0.88	1.68	0.75	2.73	7.98	16	DIMP	1
1.10	2.05	0.68	2.88	8.98	16	DIMP	8
0.62	1.30	0.30	1.53	5.32	15	DIMP	20
1.01	1.67	0.98	2.75	7.75	3	Positive control	1
1.24	2.06	0.59	2.52	7.89	2	Positive control	8
0.83	1.41	0.34	1.49	5.82	3	Positive control	20

1
2
3
4
5
6
7
8
9
10
11
12
13
14
15
16
17
18
19
20
21
22
23
24
25
26
27
28
29
30
31
32
33
34
35
36
37
38
39
40
41
42
43
44

Table A-1. Yield of Various Plants Exposed to DIMP or DCPD During Growth Period. (Sheet 3 of 5)

Leaf	Average Weight (gm)			Number of Plants in Average	Contaminant Type	Concentration of Contaminant in H ₂ O (ppm)
	Stem	Root	Edible Fruit			
ALFALFA ^b						
1.10	1.55	1.22		81	Negative control	0
1.94	2.15	1.47		65	DIMP	1
3.14	3.96	2.36		41	DIMP	1
1.13	1.19	0.94		84	DIMP	8
2.62	2.82	1.59		13	Positive control	1
1.56	1.88	1.15		16	Positive control	8
1.33	1.79	1.16		16	Positive control	20
1.42	1.74	2.25		57	DCPD	1
1.88	1.95	1.88		53	DCPD	8
1.51	1.46	1.97		55	DCPD	20
1.05	1.03	1.01		22	Positive control	1
4.68	2.14	5.06		5	Positive control	8
3.13	3.08	1.07		8	Positive control	20

1
2
3
4
5
6
7
8
9
10
11
12
13
14
15
16
17
18
19
20
21
22
23
24
25
26
27
28
29
30
31
32
33
34
35
36
37
38
39
40
41
42
43
44

1
2
3
4
5
6
7
8
9
10
11
12
13
14
15
16
17
18
19
20
21
22
23
24
25
26
27
28
29
30
31
32
33
34
35
36
37
38
39
40
41
42
43
44

Table A-1. Yield of Various Plants Exposed to DIMP or DCPD During Growth Period. (Sheet 4 of 5)

Average Weight (gm)				Number of Plants in Average	Contaminant Type	Concentration of Contaminant in H ₂ O (ppm)
Leaf	Stem	Root	Edible Fruit			
SUGAR BEET ^c						
23.9	N/A	40.9	See root	27	Negative control	0
13.8	N/A	39.8	See root	16	DIMP	1
7.3	N/A	39.6	See root	18	DIMP	8
7.9	N/A	30.5	See root	17	DIMP	20
9.8	N/A	30.7	See root	5	Positive control	1
18.3	N/A	55.5	See root	5	Positive control	8
7.7	N/A	53.3	See root	3	Positive control	20
21.5	N/A	44.7	See root	22	DCPD	1
14.1	N/A	44.5	See root	16	DCPD	8
21.1	N/A	50.7	See root	16	DCPD	20
15.1	N/A	66.5	See root	4	Positive control	1
26.1	N/A	84.4	See root	2	Positive control	8
49.1	N/A	79.8	See root	2	Positive control	20

1
2
3
4
5
6
7
8
9
10
11
12
13
14
15
16
17
18
19
20
21
22
23
24
25
26
27
28
29
30
31
32
33
34
35
36
37
38
39
40
41
42
43
44

Table A-1. Yield of Various Plants Exposed to DIMP-or-DCPD During Growth Period. (Sheet 5 of 5)

Leaf	Average Weight (gm)			Edible Fruit	Total Plant	Number of Plants in Average	Contaminant Type	Concentration of Contaminant in H ₂ O (ppm)
	Stem	Root	See root					
CARROTS								
13.7	19.6	126.6	See root	71.2	21	Negative control	0	
5.2	8.1	57.9	See root	74.4	33	DIMP	1	
5.6	10.2	58.6	See root	106.2	46	DIMP	8	
9.2	13.6	83.4	See root	51.4	16	DIMP	20	
4.5	4.6	42.3	See root	380.6	12	Positive control	1	
26.7	35.6	318.3	See root	449.5	2	Positive control	8	
34.8	33.1	381.6	See root	122.1	2	Positive control	20	
12.2	8.9	101.0	See root	135.6	26	DCPD	1	
13.6	19.1	102.9	See root	185.1	16	DCPD	8	
18.7	28.6	137.8	See root	739.2	9	DCPD	20	
48.0	43.8	647.4	See root	98.9	1	Positive control	1	
23.8	25.5	49.6	See root	772.3	4	Positive control	8	
76.9	60.8	634.6	See root		1	Positive control	20	
<p>a Average weight of plant parts at 87 days.</p> <p>b Average weight of plant parts at 116 days.</p> <p>c Average weight of plant parts at 211 days.</p> <p>d Average weight of plant parts of 229 days.</p>								

1
2
3
4
5
6
7
8
9
10
11
12
13
14
15
16
17
18
19
20
21
22
23
24
25
26
27
28
29
30
31
32
33
34
35
36
37
38
39
40
41
42
43
44

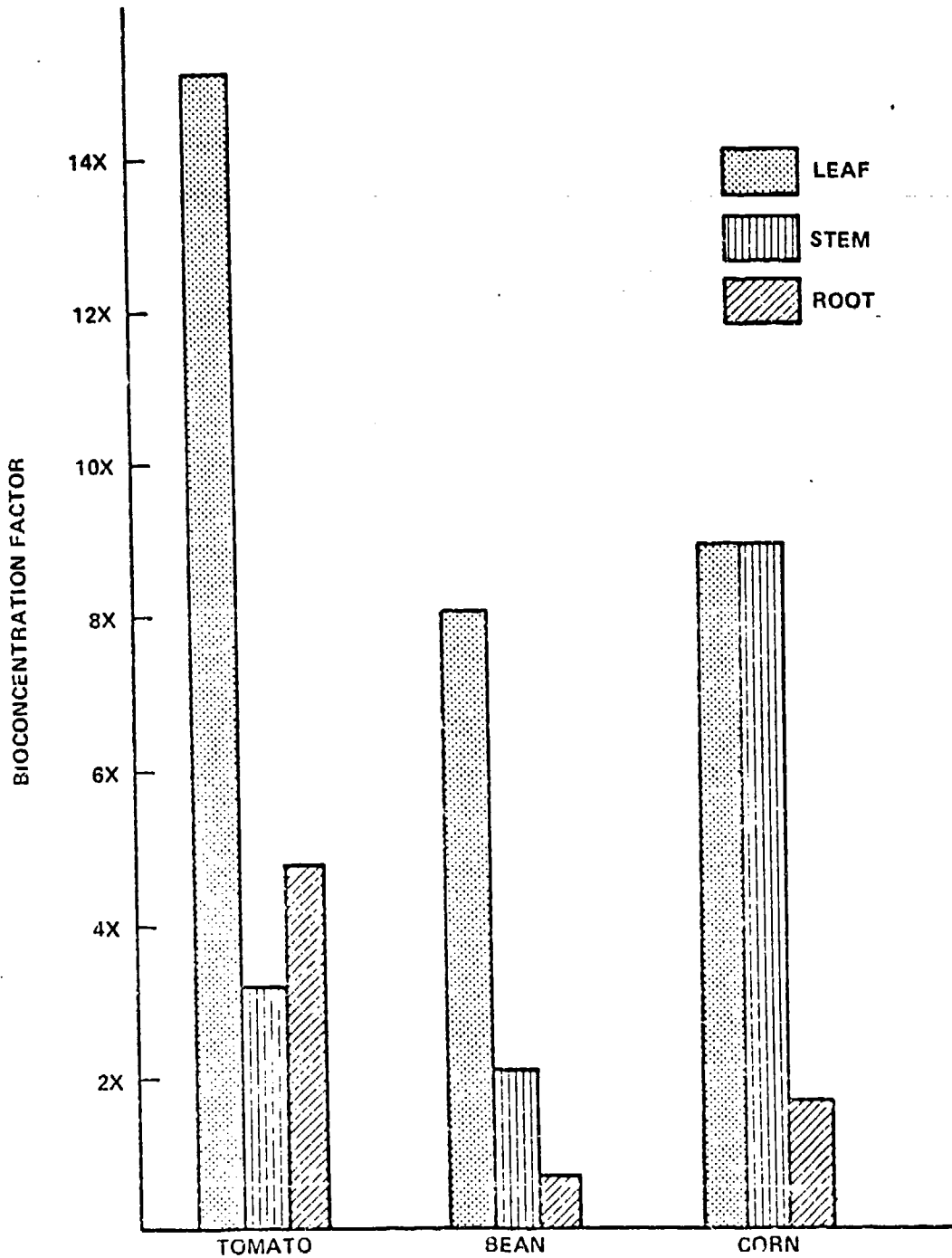

Figure A-1. Bioconcentration of DIMP in Plant Parts from 1000 ppm Contaminated Nutrient. (Sheet 1 of 3)

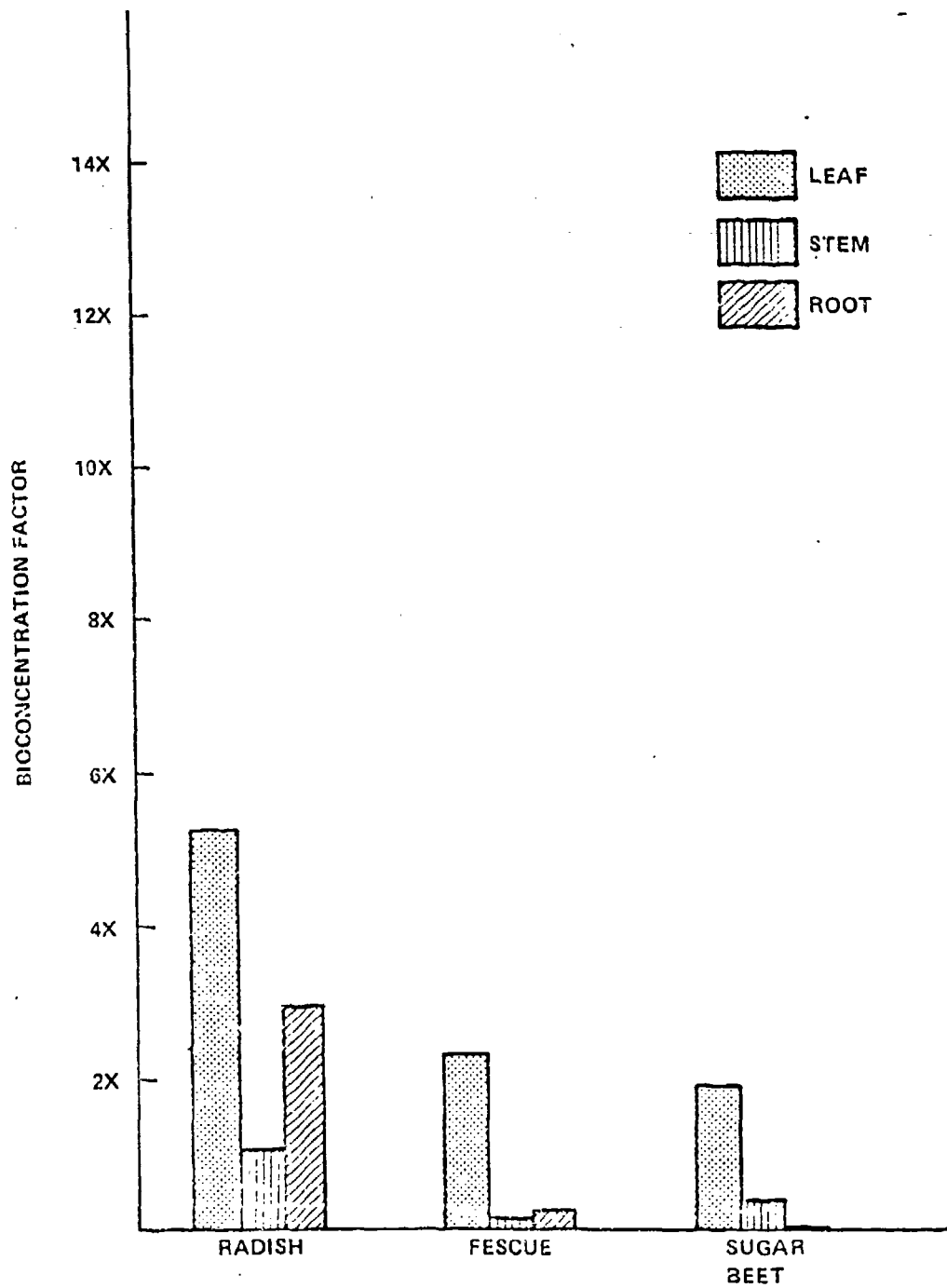

Figure A-1. Bioconcentration of DIMP in Plant Parts from 1000 ppm Contaminated Nutrient. (Sheet 2 of 3)

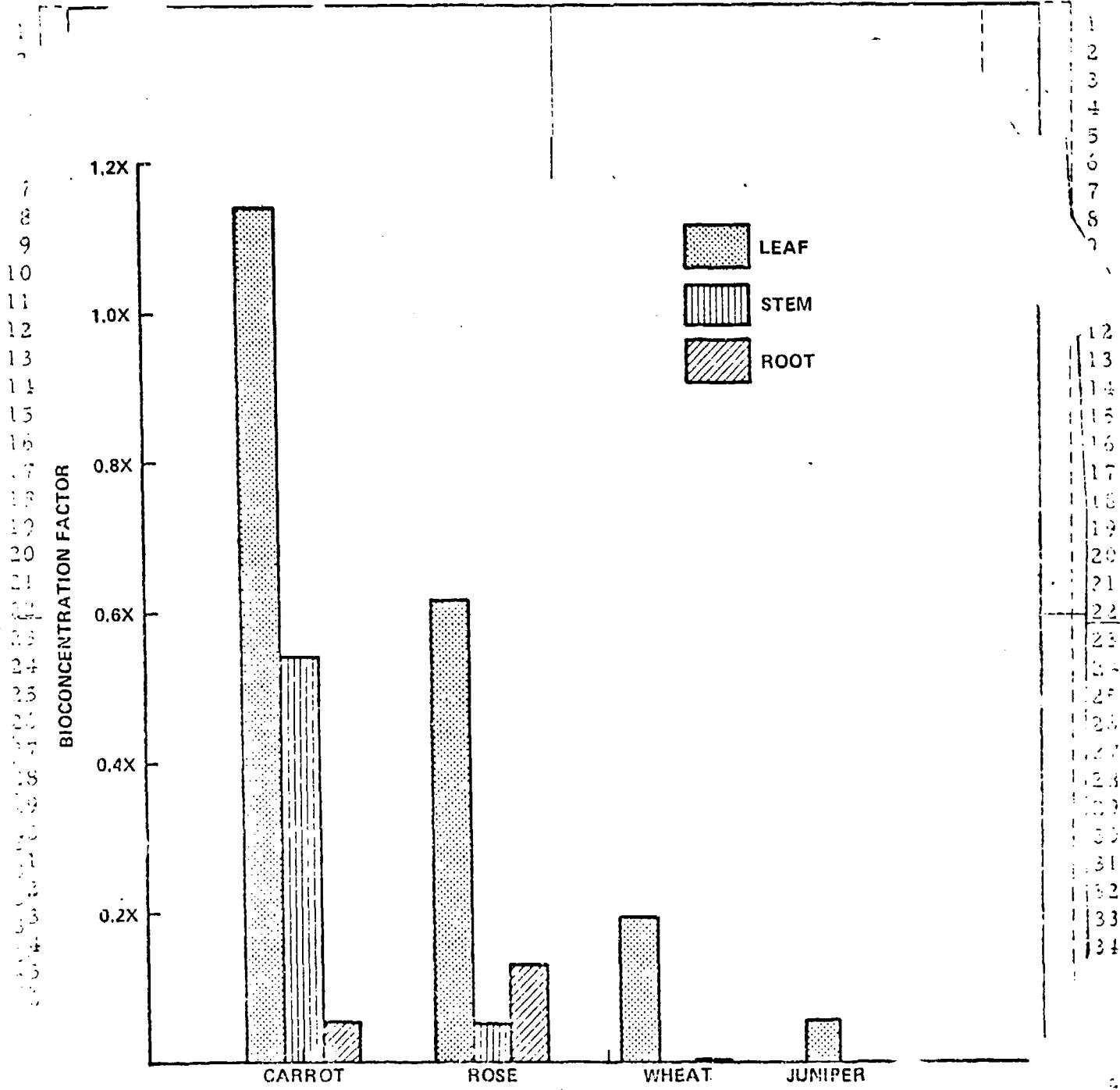

Figure A-1. Bioconcentration of DIMP in Plant Parts from 1000 ppm Contaminated Nutrient. (Sheet 3 of 3)

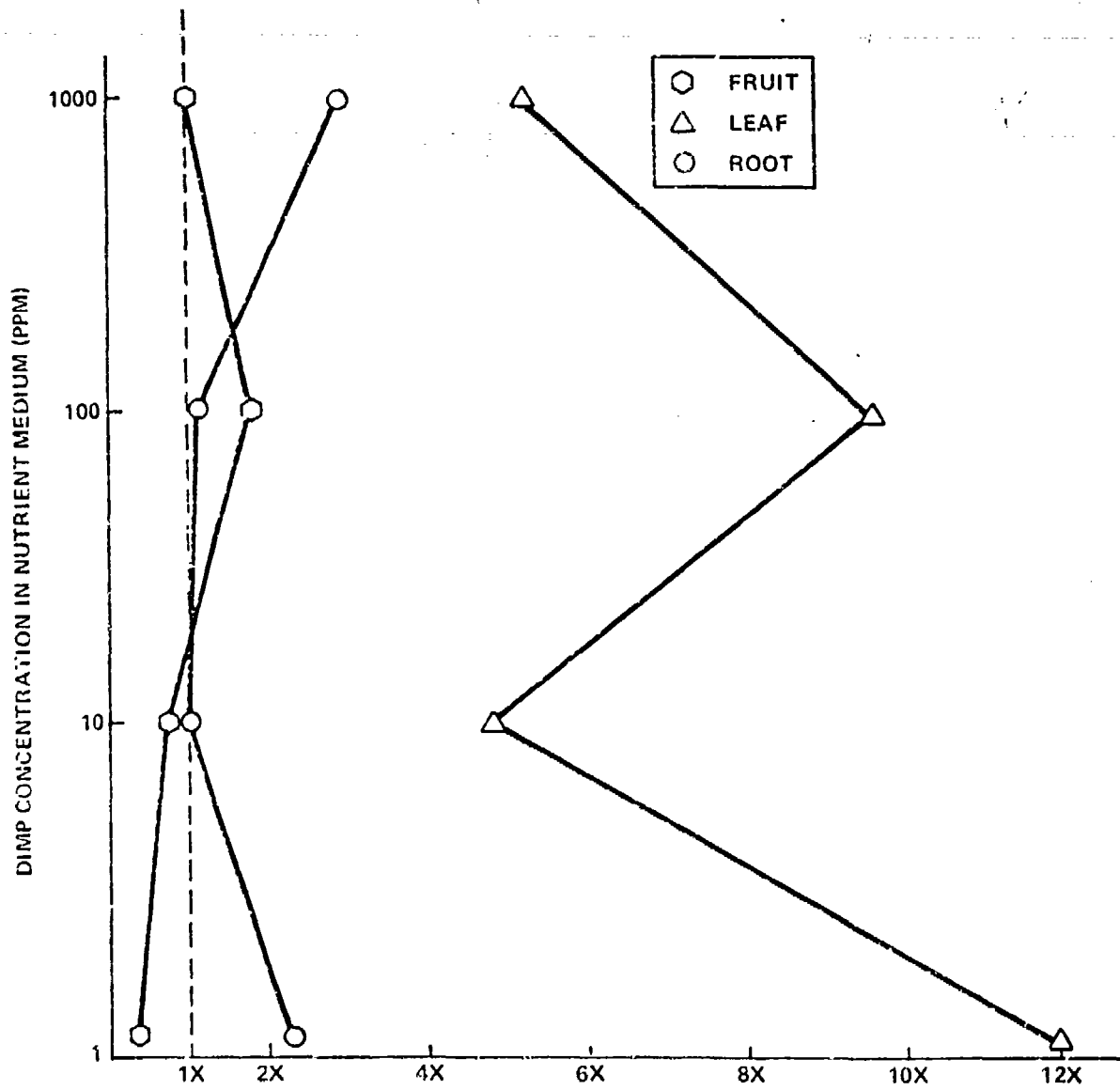

Figure A-2. Bioconcentration of DIMP in Radish Parts at Maturity.

1
2
3
4
5
6
7
8
9
10
11
12
13
14
15
16
17
18
19
20
21
22
23
24
25
26
27
28
29
30
31
32
33
34
35
36
37
38
39
40
41
42
43
44

1
2
3
4
5
6
7
8
9
10
11
12
13
14
15
16
17
18
19
20
21
22
23
24
25
26
27
28
29
30
31
32
33
34
35
36
37
38
39
40
41
42
43
44

Appendix B

DIMP AND DDPD CONCENTRATIONS
IN SOIL AND WATER

Table B-1. DIMP Content of Soil Samples (ppm)
After 426 Days, Group 1.

Depth (in.)	Avenue		Cano		Lubrication		Walnut			Brawley							
	1	2	1	2	1	2	1	2	3	1	2	3					
0 (surface)	22.9	24.7	30.3	27.4	10.0	10.0	21.3	15.7	14.3	31.0	39.0	40.3	17.5	14.8	8.1	15.8	34.4
0-6	5.0	3.1	11.3	7.4	5.0	7.7	1.5	3.9	13.2	10.9	10.4	4.0	4.1	a	5.7	7.8	5.7
6-12	3.6	3.0	8.5	7.1	1.0	8.3	1.5	3.4	5.0	12.0	1.9	5.2	11.1	a	a	5.0	11.0
12-18	1.1	1.5	3.0	0.1	5.5	5.3	1.3	3.1	7.1	7.1	6.2	3.8	5.4	12.7	6.4	9.1	5.7
18-24	3.0	2.1	4.7	3.6	4.7	7.7	4.0	3.1	5.0	10.4	4.5	3.8	7.4	8.1	4.5	8.0	8.1
24-30	1.3	2.1	3.4	1.4	5.4	4.4	4.1	3.3	6.0	9.1	5.4	5.1	5.3	10.2	6.4	8.8	5.0
30-36	0.1	2.2	3.0	1.2	5.3	4.5	0.2	2.9	13.0	10.5	5.5	5.1	7.5	12.0	6.2	4.8	7.2
36-42	1.1	2.3	2.5	1.7	5.4	4.4	0.0	2.0	7.9	7.3	6.7	4.1	6.3	9.2	5.0	5.2	7.3
42-48	1.7	2.0	2.6	1.0	4.3	3.4	5.1	2.4	9.1	7.3	5.5	4.4	11.5	13.0	5.7	3.7	6.4
48-54	1.7	2.3	2.0	2.0	6.1	6.2	3.1	3.4	12.3	6.8	5.2	4.2	7.5	14.3	4.3	4.2	5.9
54-60	2.0	3.7	1.5	10.0	5.4	4.3	5.1	2.5	6.4	5.1	4.1	7.4	4.9	8.6	4.3	4.2	7.5
a soil good																	

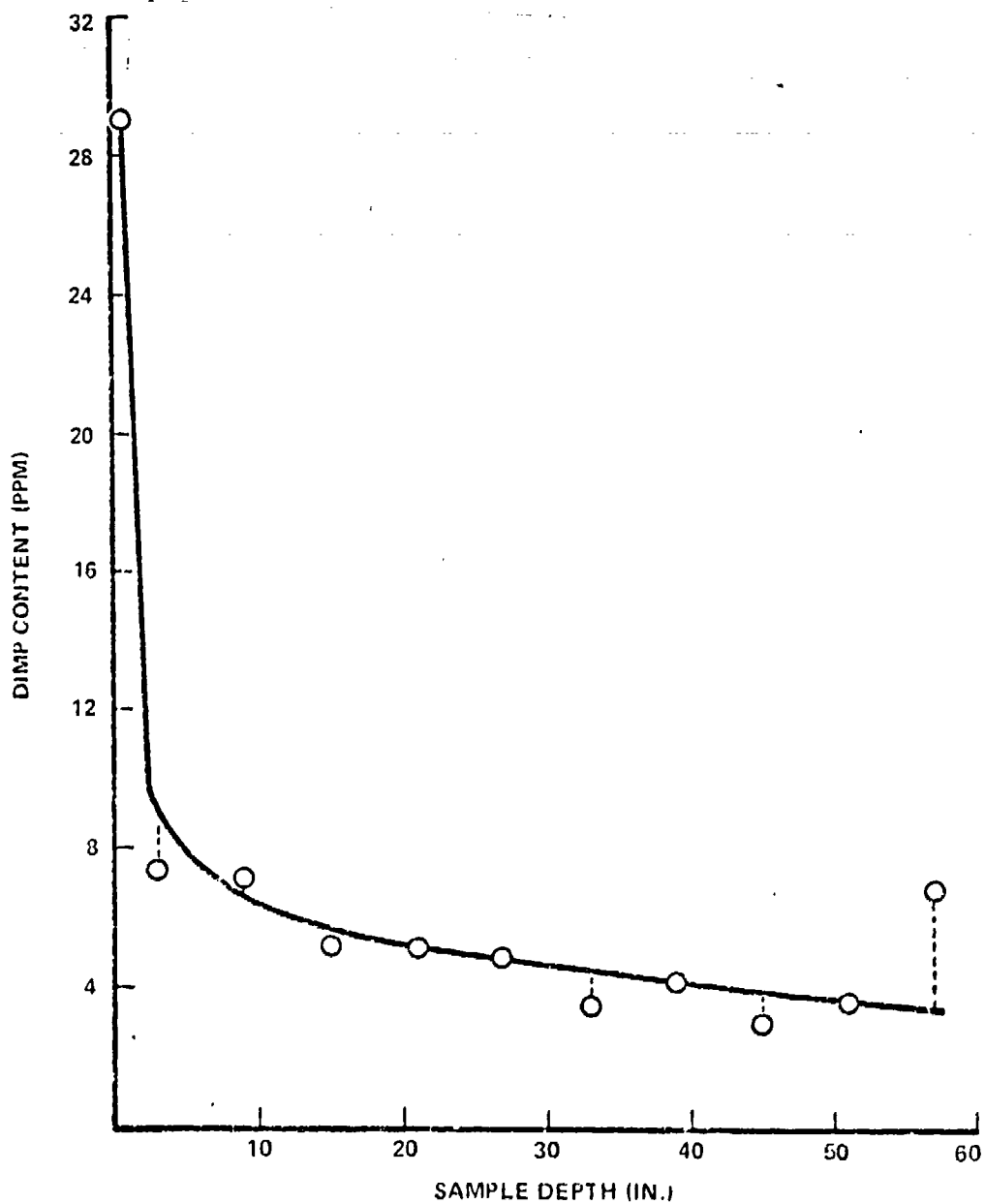

Figure B-1. DIMP Content of Chino Soil Samples, 426 Days, Group 1.

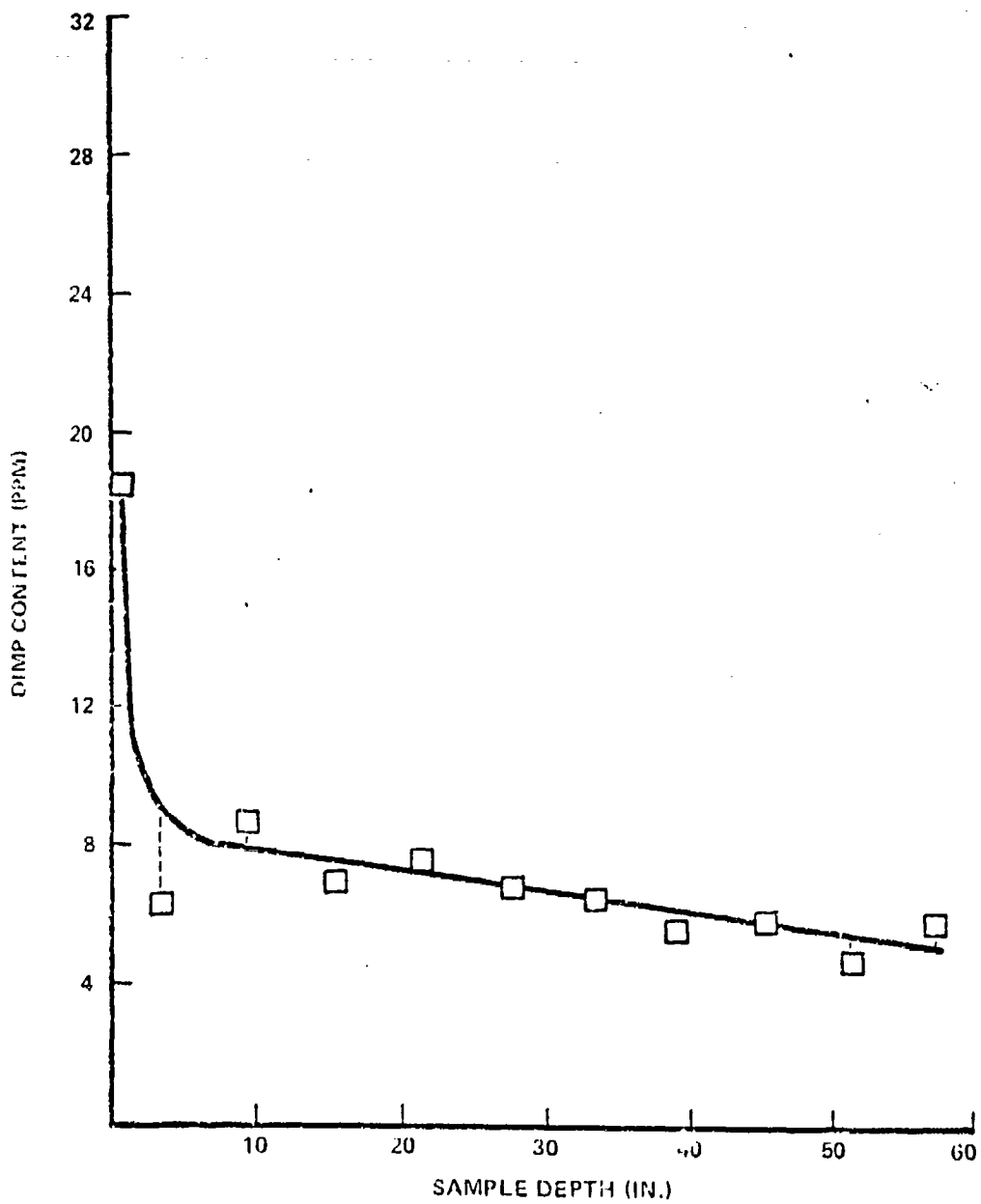

Figure B-2. DIMP Content of Brawley Soil Samples, 426 Days, Group 1.

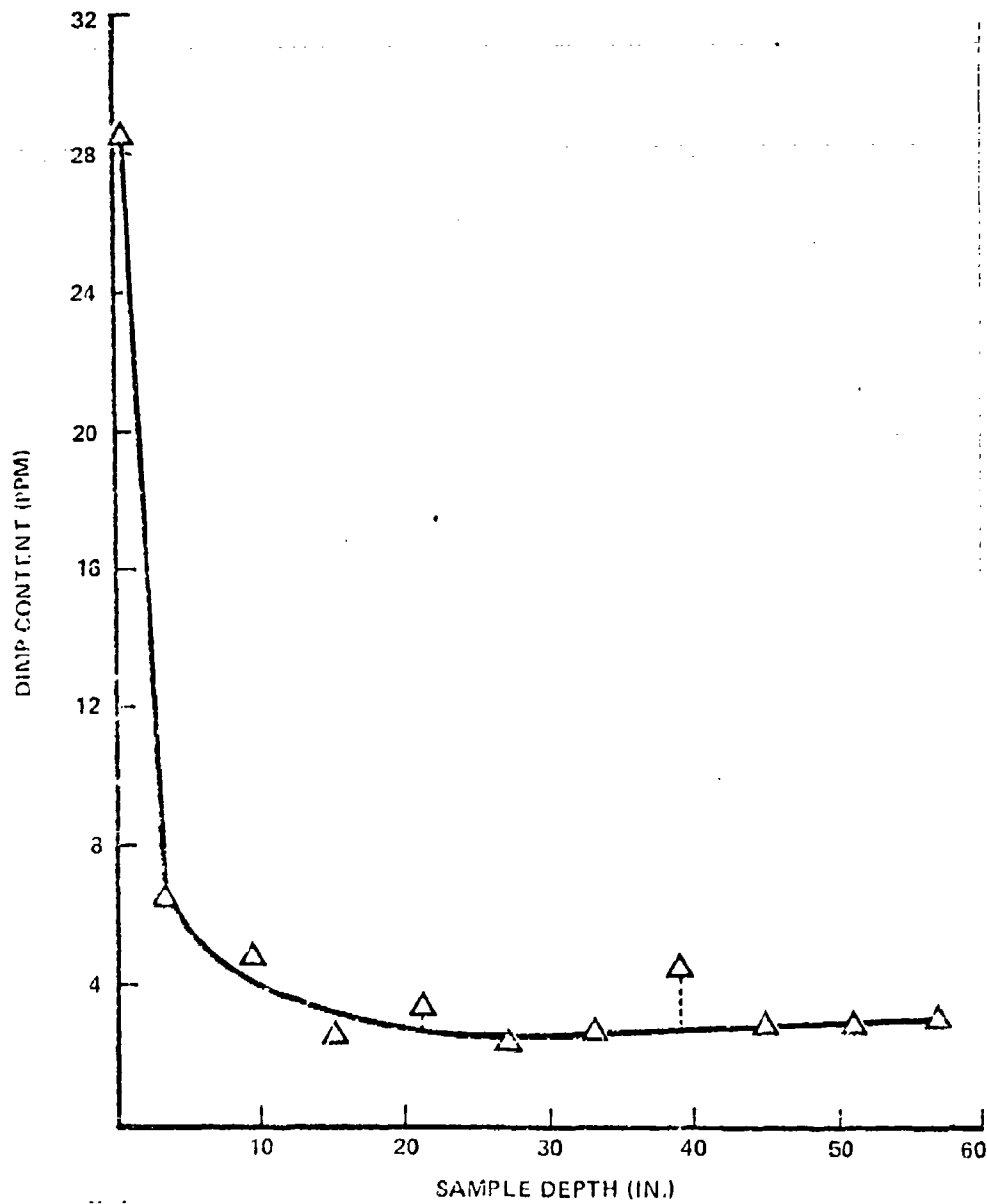

Figure B-3. DIMP Content of Ventura Soil Samples, 426 Days, Group 1.

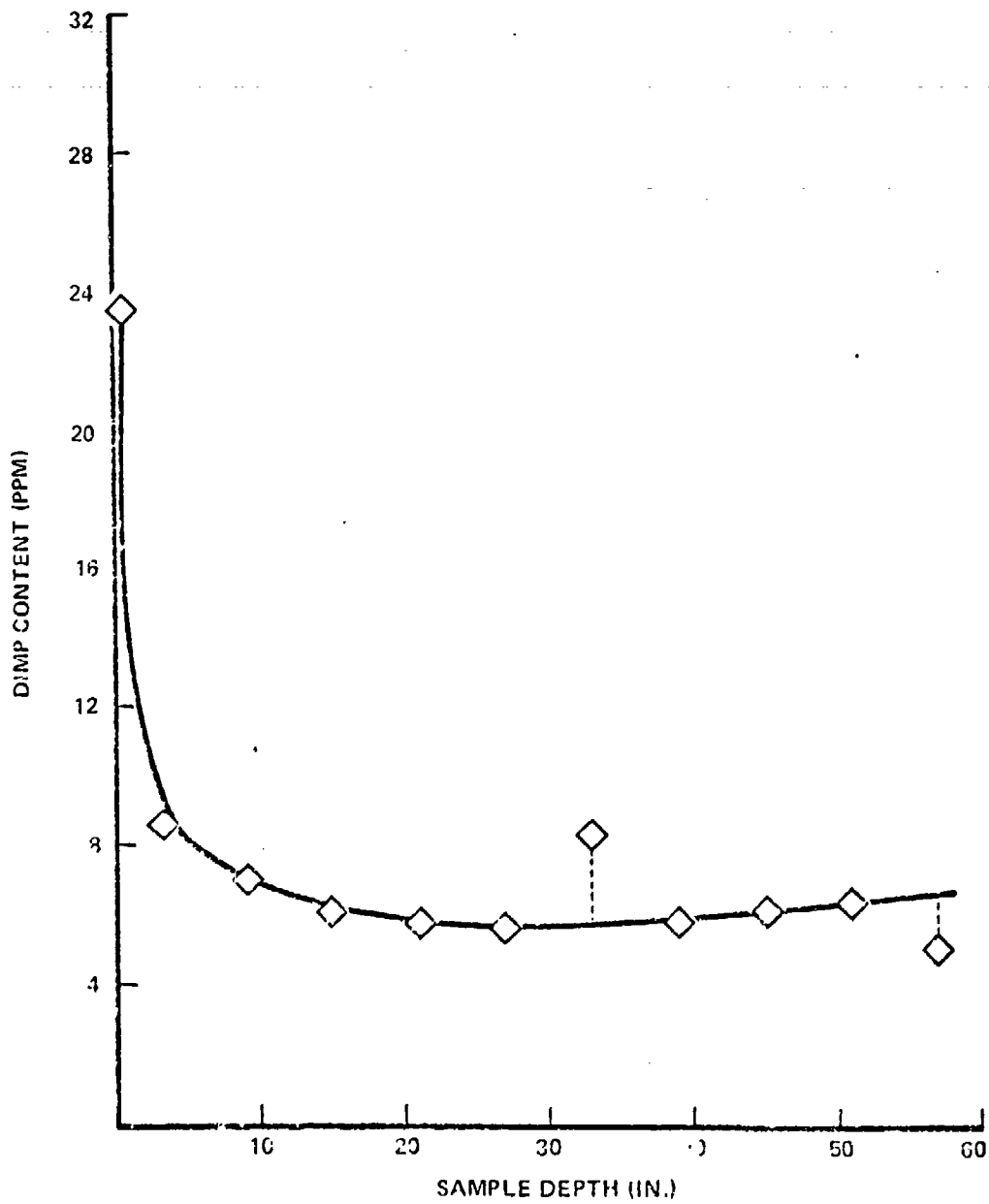

Figure B-4. DIMP Content of Fullerton Soil Samples, 426 Days. Group I.

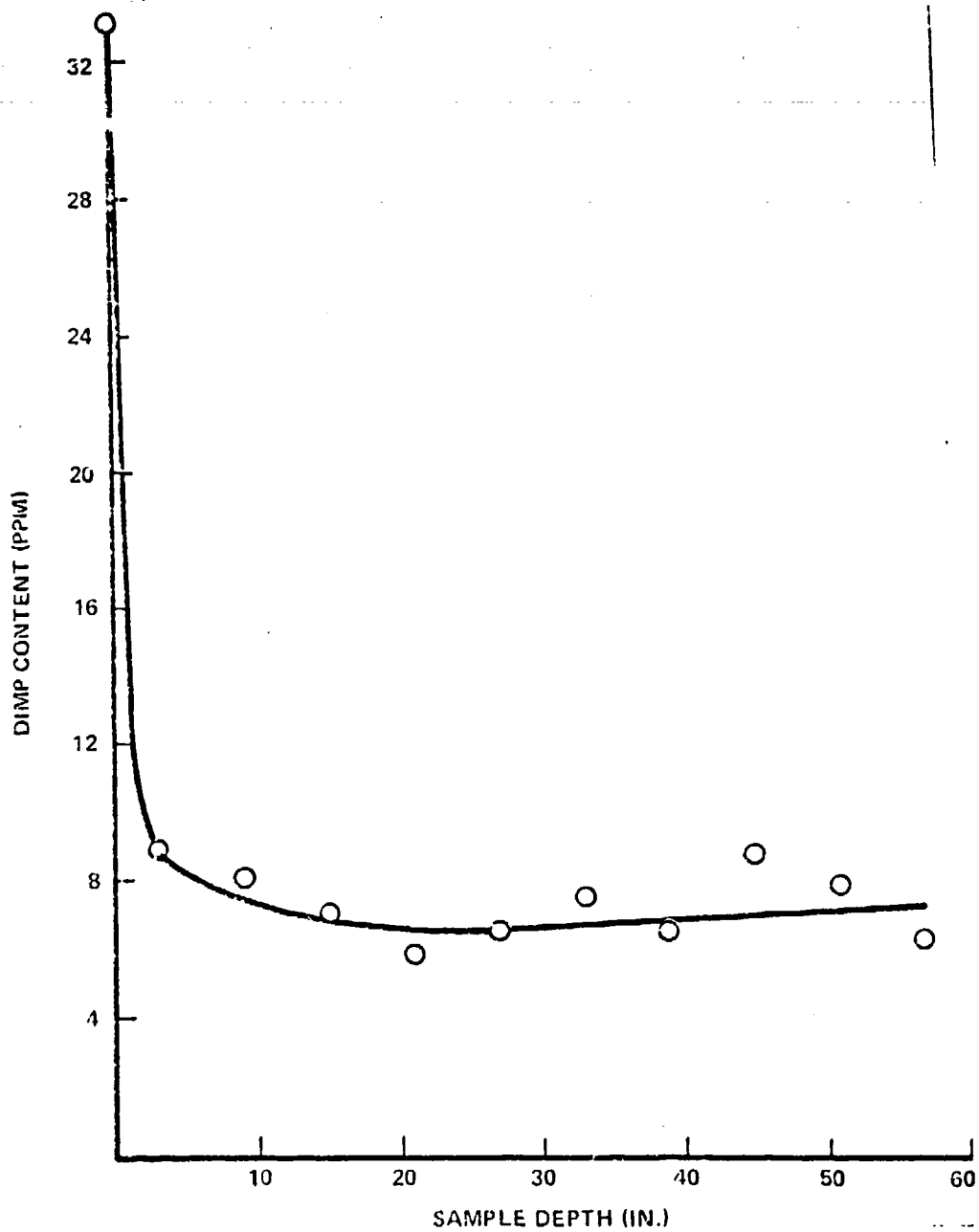

Figure B-5 . DIMP Content of Walnut Soil Samples, 426 Days, Group 1.

Table B-2. DIMP Content of Group 1 Lysimeter Soil,
 426 Days. (Sheet 1 of 3)

Sample Depth (in.)	Sample Weight (gm)	Section Weight (gm)	Concentration of DIMP in Section (ppm)	Weight of DIMP in Section (gm)	DIMP Recovered (%)
WALNUT					
0 (surface)	2.6	2,563	33.3	0.09	
0 - 6	25.8	25,434	9.0	0.23	
6 - 12	44.8	44,164	8.2	0.36	
12 - 18	38.9	38,348	7.2	0.28	
18 - 24	51.9	51,164	6.0	0.31	
24 - 30	47.6	46,925	6.5	0.31	
30 - 36	45.9	45,249	7.5	0.34	
36 - 42	37.0	36,475	6.6	0.24	
42 - 48	28.5	28,096	8.8	0.25	
48 - 54	26.8	26,420	7.8	0.21	
54 - 60	67.4	66,444	6.3	0.42	
Total				3.04	31.8
VENTURA					
0 (surface)	2.3	2,267	28.4	0.06	
0 - 6	27.3	26,913	6.5	0.17	
6 - 12	48.4	47,713	4.8	0.23	
12 - 18	44.4	43,770	2.5	0.11	
18 - 24	44.6	43,967	3.3	0.15	
24 - 30	30.8	30,363	2.4	0.07	
30 - 36	40.5	39,925	2.7	0.11	

Table B-2. DIMP Content of Group 1 Lysimeter Soil,
426 Days. (Sheet 2 of 3)

Sample Depth (in.)	Sample Weight (gm)	Section Weight (gm)	Concentration of DIMP in Section (ppm)	Weight of DIMP in Section (gm)	DIMP Recovered (%)
36 - 42	32.8	32,335	4.5	0.15	
42 - 48	59.6	58,754	2.9	0.17	
48 - 54	68.9	67,922	2.8	0.19	
54 - 60	86.3	85,075	3.1	0.26	
				1.67	17.5
FULLERTON					
0 (surface)	3.3	3,253	23.6	0.08	
0 - 6	23.0	22,674	8.7	0.20	
6 - 12	48.3	47,615	7.1	0.34	
12 - 18	44.3	43,671	6.1	0.27	
18 - 24	47.5	46,826	5.9	0.28	
24 - 30	41.6	41,010	5.7	0.23	
30 - 36	24.6	24,251	8.3	0.20	
36 - 42	34.3	33,813	5.8	0.20	
42 - 48	37.2	36,672	6.1	0.22	
48 - 54	35.4	34,898	6.4	0.22	
54 - 60	77.9	76,795	4.9	0.38	
				2.62	27.5
BRAWLEY					
0 (surface)	4.8	4,732	18.4	0.09	
0 - 6	31.3	30,856	6.5	0.20	
6 - 12	17.2	16,956	8.6	0.15	

Table B-2. DIMP Content of Group I Lysimeter Soil,
426 Days. (Sheet 3 of 3)

Sample Depth (in.)	Sample Weight (gm)	Section Weight (gm)	Concentration of DIMP in Section (ppm)	Weight of DIMP in Section (gm)	DIMP Recovered (%)
12 - 18	14.4	14,196	7.0	0.10	
18 - 24	12.1	11,928	7.6	0.09	
24 - 30	14.3	14,097	6.9	0.10	
30 - 36	21.7	21,392	6.6	0.14	
36 - 42	31.7	31,250	5.7	0.18	
42 - 48	52.9	52,149	6.0	0.31	
48 - 54	48.8	48,108	5.0	0.24	
54 - 60	73.4	72,358	5.8	0.42	
				<u>2.02</u>	<u>21.2</u>
CHINO					
0 (surface)	2.2	2,169	28.9	0.06	
0 - 6	46.2	45,544	7.4	0.34	
6 - 12	53.6	52,839	7.1	0.38	
12 - 18	55.3	54,515	5.3	0.29	
18 - 24	60.7	59,839	5.2	0.31	
24 - 30	62.4	61,515	4.9	0.30	
30 - 36	59.3	58,459	3.5	0.20	
36 - 42	59.2	58,360	4.1	0.24	
42 - 48	54.0	53,234	3.0	0.16	
48 - 54	52.2	51,459	3.5	0.18	
54 - 60	62.9	62,007	6.8	0.42	30.2
				<u>2.88</u>	<u>30.2</u>

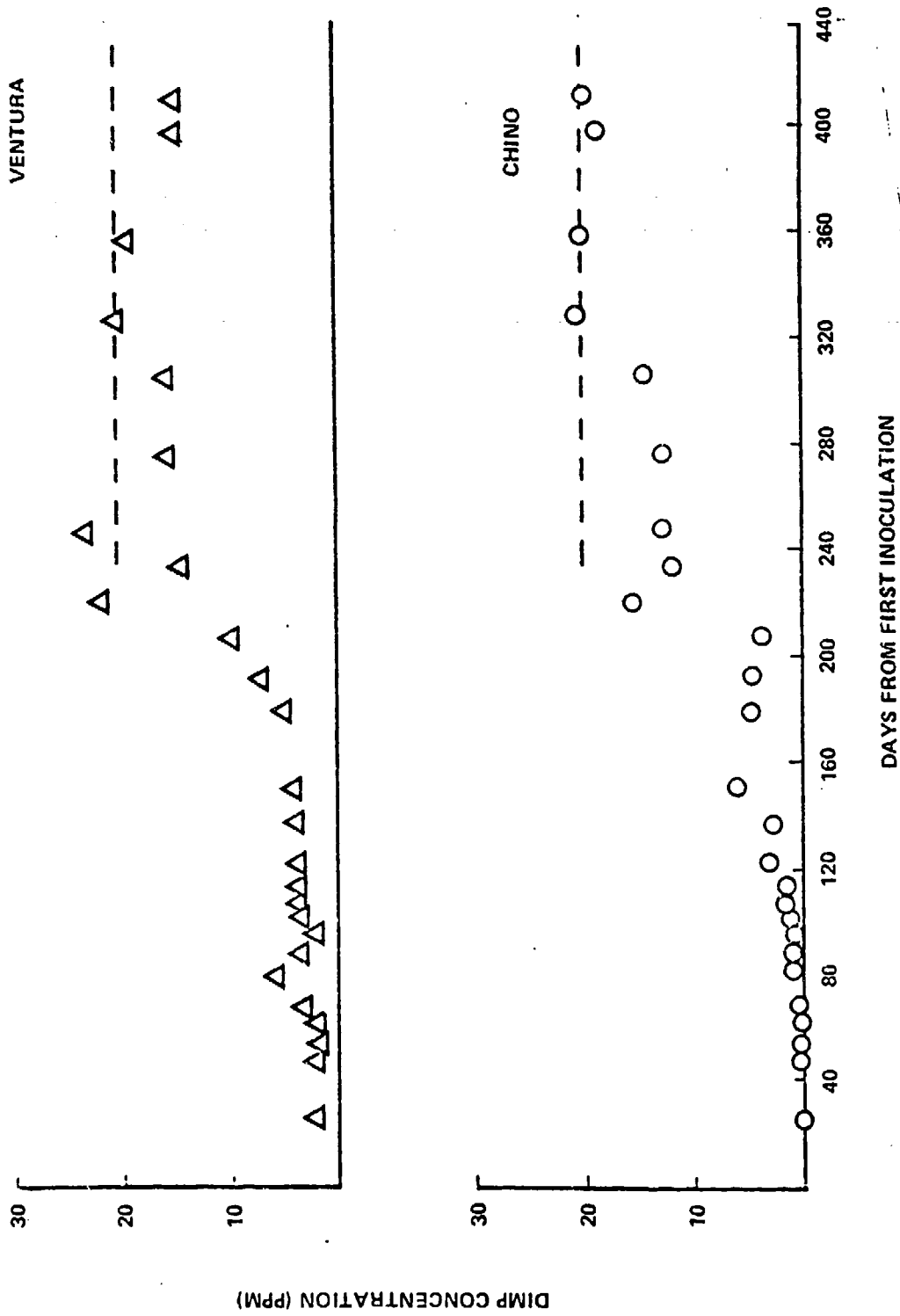

Figure B-6. Concentration of DIMP in 60-in. Sample of Lysimeter Water (Sheet 1 of 3).



Figure B-6. Concentration of DIMP in 60-in. Sample of Lysimeter Water (Sheet 2 of 3).

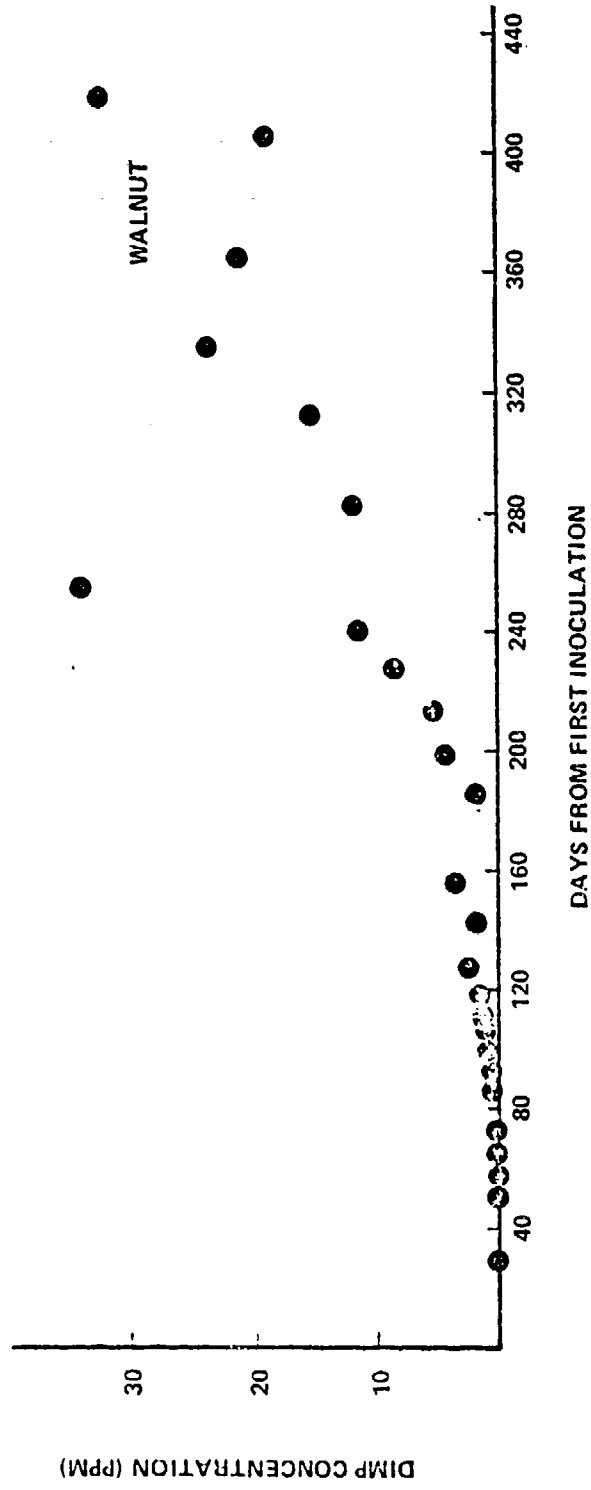

Figure B-6. Concentration of DIMP in 60-in. Sample of Lysimeter Water (Sheet 3 of 3).

Table B-3 . DIMP Content of Soil Samples (ppm)
After 322 Days, Group 2.

Depth (in.)	Ventura			China			Fullerton			Walnut			Brawley			
0 (surface)	3	3	3	3	3	3	3	3	3	3	3	3	3	3	3	3
0 - 6	4	4	4	4	4	4	4	4	4	4	4	4	4	4	4	4
6 - 12	4	4	4	4	4	4	4	4	4	4	4	4	4	4	4	4
12 - 18	2	2	2	2	2	2	2	2	2	2	2	2	2	2	2	2
18 - 24	2	2	2	2	2	2	2	2	2	2	2	2	2	2	2	2
24 - 30	0.6	3.1	2.9	6.2	2.9	6.2	2.9	6.2	2.9	6.2	2.9	6.2	2.9	6.2	2.9	6.2
30 - 36	1.7	6.6	4.8	8.6	4.8	8.6	4.8	8.6	4.8	8.6	4.8	8.6	4.8	8.6	4.8	8.6
36 - 42	3.4	7.3	6.2	11.7	6.2	11.7	6.2	11.7	6.2	11.7	6.2	11.7	6.2	11.7	6.2	11.7
42 - 48	7.7	11.2	9.1	10.6	9.1	10.6	9.1	10.6	9.1	10.6	9.1	10.6	9.1	10.6	9.1	10.6
48 - 54	14.5	15.3	9.3	7.8	5.0	7.9	10.1	6.4	10.3	15.0	10.1	8.6	4.1	4.6	9.0	9.5
54 - 60	12.3	8.8	5.1	2.1	2.3	3.7	1.1	1.1	4.3	22.8	7.7	8.5	6.2	7.6	14.9	10.5
a < 0.1																

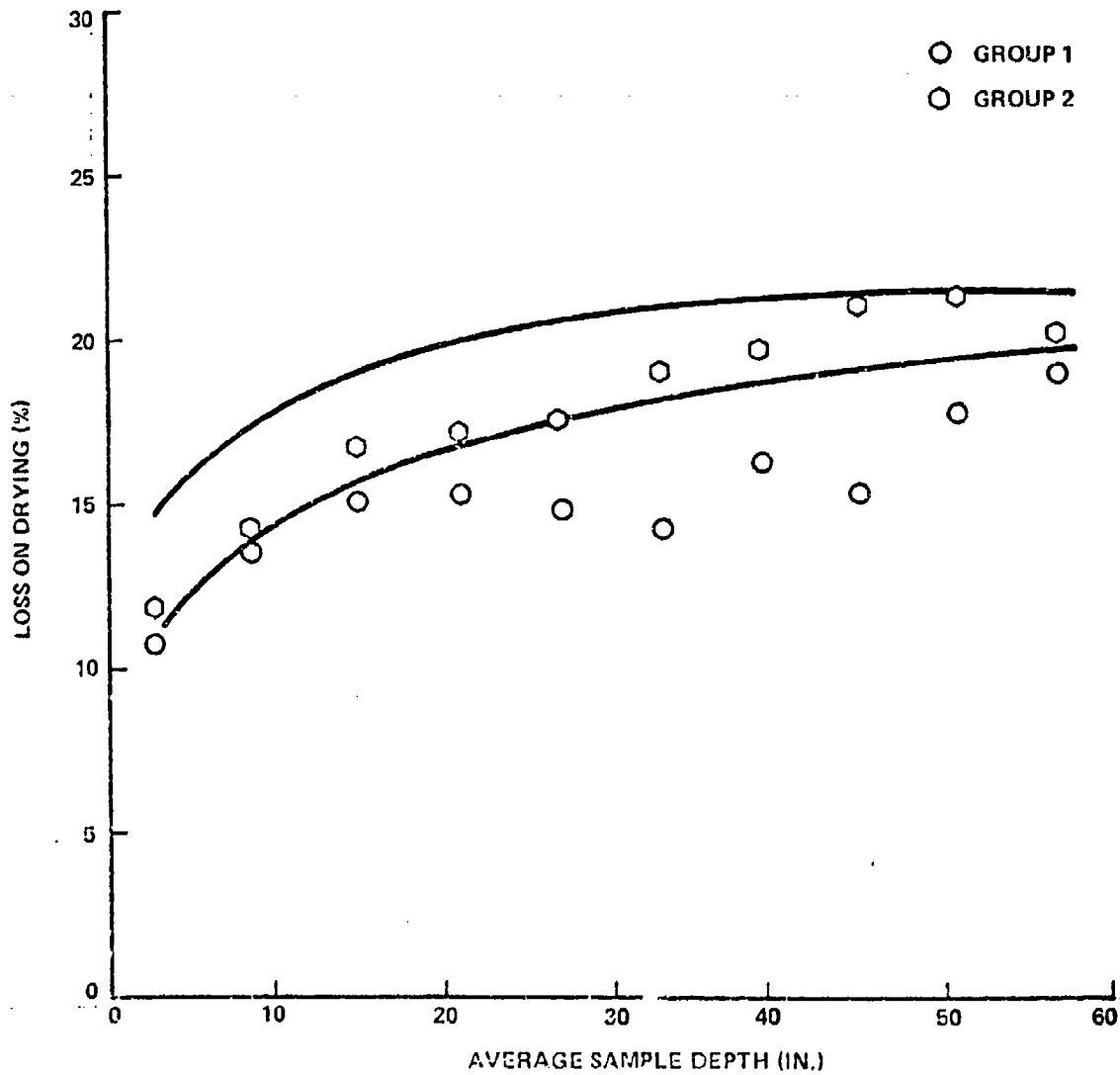

Figure B-7. Average Moisture Content of Lysimeters (After 2 Week Drainage).

Table B-4. DIMP Content of Group 2 Lysimeter Soil
After 322 Days. (Sheet 1 of 3)

Sample Depth (in.)	Sample Weight (gm)	Section Weight (gm)	Concentration of DIMP in Section (ppm)	Weight of DIMP in Section (gm)	DIMP Recovered (%)
CHINO					
0 (surface)	3.6	3,549	a	a	
0 - 6	32.4	31,940	a	a	
6 - 12	57.3	56,462	a	a	
12 - 18	49.6	48,921	a	a	
18 - 24	67.6	66,641	a	a	
24 - 30	69.9	68,908	2.3	0.16	
30 - 36	65.0	64,078	4.0	0.26	
36 - 42	60.5	59,642	9.5	0.57	
42 - 48	56.1	55,255	11.1	0.61	
48 - 54	46.5	45,865	7.4	0.34	
54 - 60	55.4	54,565	3.0	0.16	
				2.1	37.5
BRAWLEY					
0 (surface)	6.1	5,991	a	a	
0 - 6	25.2	24,793	a	a	
6 - 12	27.0	26,592	a	a	
12 - 18	27.6	27,208	a	a	
18 - 24	20.4	20,110	a	a	
24 - 30	21.0	20,677	1.6	0.03	
30 - 36	34.1	33,641	14.5	0.49	
36 - 42	47.0	46,333	17.0	0.79	

Table B-4. DIMP Content of Group 2 Lysimeter Soil
 After 322 Days. (Sheet 2 of 3)

Sample Depth (in.)	Sample Weight (gm)	Section Weight (gm)	Concentration of DIMP in Section (ppm)	Weight of DIMP in Section (gm)	DIMP Recovered (%)
42 - 48	60.7	59,789	9.1	0.54	
48 - 54	72.4	71,422	4.5	0.32	
54 - 60	85.3	84,040	2.9	0.24	
				2.41	46.2
VENTURA					
0 (surface)	5.6	5,521	a	0	
0 - 6	39.4	38,841	a	0	
6 - 12	42.3	41,675	a	0	
12 - 18	25.9	25,533	a	0	
18 - 24	32.5	32,039	a	0	
24 - 30	31.4	31,004	0.9	0.03	
30 - 36	29.4	28,983	3.5	0.10	
36 - 42	39.3	38,767	9.4	0.36	
42 - 48	59.3	58,483	10.7	0.63	
48 - 54	69.4	68,415	11.7	0.80	
54 - 60	86.9	85,642	7.1	0.61	
				2.53	42.3
FULLERTON					
0 (surface)	4.0	3,943	a	a	
0 - 6	32.0	31,546	a	a	
6 - 12	50.5	49,783	a	a	
12 - 18	42.2	41,601	a	a	

Table B-4. DIMP Content of Group 2 Lysimeter Soil
After 322 Days. (Sheet 3 of 3)

Sample Depth (in.)	Sample Weight (gm)	Section Weight (gm)	Concentration of DIMP in Section (ppm)	Weight of DIMP in Section (gm)	DIMP Recovered (%)
18 - 24	39.7	39,137	a	a	
24 - 30	31.5	31,053	a	a	
30 - 36	39.7	39,137	a	a	
36 - 42	36.2	35,686	9.7	0.35	
42 - 48	35.3	34,799	12.8	0.45	
48 - 54	37.9	37,362	8.5	0.32	
54 - 60	79.4	78,273	11.3	0.88	
				<u>2.0</u>	<u>38.3</u>
WALNUT					
0 (surface)	4.1	4,042	a	a	
0 - 6	33.1	32,630	a	a	
6 - 12	51.6	50,868	a	a	
12 - 18	37.8	37,264	a	a	
18 - 24	45.3	44,657	a	a	
24 - 30	31.9	31,447	a	a	
30 - 36	36.3	35,785	a	a	
36 - 42	40.4	39,827	a	a	
42 - 48	26.8	26,420	3.0	0.08	
48 - 54	30.0	29,574	6.8	0.20	
54 - 60	52.7	51,952	9.8	0.51	
				<u>0.79</u>	<u>14.8</u>
^a Less than 0.1 ppm.					