

AD A 995229

DTIC ACCESSION NUMBER

LEVEL

INVENTORY

WT-784  
NOLR-1181

Feb '55

DOCUMENT IDENTIFICATION

DISTRIBUTION STATEMENT A

Approved for public release;  
Distribution Unlimited

DISTRIBUTION STATEMENT

ACCESSION FOR

NTIS GRA&I

DTIC TAB

UNANNOUNCED

JUSTIFICATION

BY

DISTRIBUTION /

AVAILABILITY CODES

DIST

AVAIL AND/OR SPECIAL

A/1

Released



DTIC  
ELECTE  
S AUG 27 1984 D  
D

DATE ACCESSIONED

\* Per: telecon w/Betty Fox, Chief, DNA Tech Libr'y.  
Div.: the Classified References contained herein  
may remain. 5 Sept. '79  
Vic LaChance  
DDA-2

\*\*Verified for Extracted Versions.  
9 July '80  
pfcooper, DTIC/DDA-2

DISTRIBUTION STAMP

UNANNOUNCED

84 08 21 148

DATE RECEIVED IN DTIC

REGISTERED OR CERTIFIED NO.

PHOTOGRAPH THIS SHEET AND RETURN TO DTIC-DDAC

AD A995229

# Operation UPSHOT-KNOTHOLE

NEVADA PROVING GROUNDS

March - June 1953

Project 1.1a-1

EVALUATION OF WIANCKO AND VIBROTRON  
GAGES AND DEVELOPMENT OF NEW CIRCUITRY  
FOR ATOMIC BLAST MEASUREMENTS

12056  
TECHNICAL LIBRARY  
of the  
ARMED FORCES  
SPECIAL WEAPONS PROJECT  
11 Apr 53



Classification (Cancelled) (changed to UNCLASSIFIED)  
Authority of Memorandum for Sec 2  
By: [Signature]

100A

*CO. Mantie  
for Chief ISEM/DNA*

HEADQUARTERS FIELD COMMAND, ARMED FORCES SPECIAL WEAPONS PROJECT  
SANDIA BASE, ALBUQUERQUE, NEW MEXICO

P 3819

UNCLASSIFIED

Reproduced Direct from Manuscript Copy by  
AEC Technical Information Service  
Oak Ridge, Tennessee

Inquiries relative to this report may be made to  
Chief, Armed Forces Special Weapons Project  
Washington, D. C.

If this report is no longer needed, return to  
AEC Technical Information Service  
P. O. Box 401  
Oak Ridge, Tennessee

**OFFICIAL USE ONLY**

**UNCLASSIFIED**

WT-784

OPERATION UPSHOT-KNOTHOLE

Project 1.1a-1

**EVALUATION OF WIANCKO AND VIBROTRON  
GAGES AND DEVELOPMENT OF NEW CIRCUITRY  
FOR ATOMIC BLAST MEASUREMENTS**

*REPORT TO THE TEST DIRECTOR*

by

Joseph Petes  
C. C. Little  
J. L. Dossey, Lt., USAF

February 1955

*CG Montee  
for Chief 15cm Data*



Naval Ordnance Laboratory Report NOLR-1181  
U. S. Naval Ordnance Laboratory  
White Oak, Silver Spring, Maryland

**OFFICIAL USE ONLY**

**UNCLASSIFIED**

## ABSTRACT

A program to test experimental instrumentation was undertaken by the Naval Ordnance Laboratory on Operation UPSHOT-KNOTHOLE in an endeavor to improve existing blast phenomena measuring equipment and techniques. Four experimental designs were tested: (1) a field unit oscillator-amplifier using transistor circuit elements, (2) a sub-miniature two-wire field unit, (3) a commercially developed Vibrotron gage and amplifier unit, and (4) a frequency deviation multiplier circuit for obtaining increased signal to noise ratios. The operation also provided the opportunity to evaluate more fully the performance of the Wiancko gage. It was found that transistor circuitry is little, if at all, affected by atomic blast phenomena and holds much promise for further development. The sub-miniature two-wire system was successful and offers many advantages in economy and adaptability in field use over the present NOL system. The deviation multiplier scheme was completely successful; however, its complexity must be weighed against the freedom from noise required on any particular operation. The Vibrotron gage and oscillator was unstable, not rugged, and in general gave poor results; it requires a good deal of redesign and development before it can be used in atomic effects measuring programs. The NOL modified Wiancko pressure gage proved to be an acceptable gage, giving results superior to those obtained on previous operations with other inductance type gages. In certain applications, the acceleration sensitivity of the gage is excessive and confuses the pressure-time record. Also the damping characteristics of the gage could be improved.

**UNCLASSIFIED**

3

~~OFFICIAL USE ONLY~~

## FOREWORD

This report is one of the reports presenting the results of the 78 projects participating in the Military Effects Tests Program of Operation UPSHOT-KNOTHOLE, which included 11 test detonations. For readers interested in other pertinent test information, reference is made to WP-782, Summary Report of the Technical Director, Military Effects Program. This summary report includes the following information of possible general interest.

- a. An over-all description of each detonation, including yield, height of burst, ground zero location, time of detonation, ambient atmospheric conditions at detonation, etc., for the 11 shots.
- b. Compilation and correlation of all project results on the basic measurements of blast and shock, thermal radiation, and nuclear radiation.
- c. Compilation and correlation of the various project results on weapons effects.
- d. A summary of each project, including objectives and results.
- e. A complete listing of all reports covering the Military Effects Tests Program.

**UNCLASSIFIED**

~~OFFICIAL USE ONLY~~

ACKNOWLEDGMENTS

Grateful acknowledgment is tendered to E. J. Culling for his advice and help in overall planning of this program and to P. S. Bengston who designed the transistor oscillator-amplifier and the deviation multiplier circuits.

Appreciation is also expressed to all personnel participating in Project 1.1a of Operation UPSHOT-KNOTHOLE for assistance in the laboratory and in the field.

**UNCLASSIFIED**  
7

~~OFFICIAL USE ONLY~~

CONTENTS

ABSTRACT . . . . . 3

FOREWORD . . . . . 5

ACKNOWLEDGMENTS . . . . . 7

ILLUSTRATIONS . . . . . 11

TABLES . . . . . 11

CHAPTER 1 INTRODUCTION AND OBJECTIVES . . . . . 13

    1.1 Introduction . . . . . 13

    1.2 Objectives . . . . . 14

CHAPTER 2 TRANSISTOR OSCILLATOR-AMPLIFIER . . . . . 15

    2.1 Design . . . . . 15

    2.2 Performance . . . . . 15

    2.3 Conclusions and Recommendations . . . . . 19

CHAPTER 3 SUB-MINIATURE TWO-WIRE FIELD UNIT . . . . . 20

    3.1 Design . . . . . 20

    3.2 Performance . . . . . 21

    3.3 Conclusions and Recommendations . . . . . 23

CHAPTER 4 VIBROTRON GAGE AND AMPLIFIER . . . . . 24

    4.1 Design . . . . . 24

    4.2 Performance . . . . . 27

    4.3 Conclusions and Recommendations . . . . . 28

CHAPTER 5 DEVIATION MULTIPLIER . . . . . 29

    5.1 Introduction . . . . . 29

    5.2 Design . . . . . 29

        5.2.1 General . . . . . 30

**UNCLASSIFIED**  
9

~~OFFICIAL USE ONLY~~

5.2.2	Circuit . . . . .	30
5.3	Performance . . . . .	33
5.4	Conclusions and Recommendations . . . . .	35
CHAPTER 6 THE WIANCKO PRESSURE GAGE . . . . .		36
6.1	Introduction . . . . .	36
6.1.1	General . . . . .	36
6.1.2	Gage Requirements . . . . .	36
6.2	The Wiancko Pressure Gage . . . . .	36
6.2.1	General Description . . . . .	36
6.2.2	Design Specifications . . . . .	38
6.3	Electrical Characteristics . . . . .	39
6.3.1	Q of Coil . . . . .	39
6.3.2	Frequency Deviation . . . . .	40
6.4	Mechanical Characteristics . . . . .	42
6.4.1	Frequency Response . . . . .	42
6.4.2	Damping . . . . .	43
6.4.3	Acceleration Sensitivity . . . . .	45
6.4.4	Temperature Dependence . . . . .	50
6.5	Calibration Technique . . . . .	50
6.6	Accuracy . . . . .	50
6.7	Field Performance . . . . .	51
6.8	Conclusions and Recommendations . . . . .	52
BIBLIOGRAPHY . . . . .		53

~~OFFICIAL USE ONLY~~  
**UNCLASSIFIED**

ILLUSTRATIONS

2.1	Circuit Diagram of the Transistor Oscillator Amplifier . . .	16
2.2	Vacuum Tube Equivalent of the Transistor Oscillator-Amplifier	17
2.3	Comparison of a Transistor Circuitry Produced Pressure-Time Record with a Standard Record . . . . .	18
3.1	Circuit Diagram of Sub-Miniature Two-wire Oscillator-Amplifier . . . . .	20
3.2	Sub-Miniature Two-wire Oscillator-Amplifier and Gage Field Unit . . . . .	22
4.1	Circuit Diagram of the Vibrotron Gage and Oscillator . . .	25
4.2	Circuit Diagram of the Vibrotron Line Amplifier . . . . .	26
4.3	Vibrotron Gage and Amplifier Pressure-Time Record . . . . .	27
5.1	Block Diagram of the Deviation Multiplier . . . . .	31
5.2	Circuit Diagram of the Deviation Multiplier . . . . .	32
5.3	Deviation Multiplier Unit . . . . .	34
5.4	Pressure-Time Record Produced by the Deviation Multiplier System . . . . .	35
6.1	Wiancko Pressure Gage . . . . .	37
6.2	Wiancko Pressure Gage Sensing Element . . . . .	38
6.3	Q of Coil vs Frequency of Oscillator - Wiancko Gage . . . . .	40
6.4	Q of Coil vs Pressure - Wiancko Gage . . . . .	41
6.5	Modes of Vibration in the Wiancko Gage . . . . .	43
6.6	Dynamic Response of the Wiancko Gage Showing Creep . . . . .	44
6.7	Dynamic Response of the Wiancko Gage with Optimum Damping . . . . .	44
6.8	Acceleration Effect vs Frequency of Vibration - Wiancko Gage	47
6.9	Acceleration Effect vs Acceleration Due to Drop Impact . . .	48
6.10	Dynamic Response of Wiancko Gage to Transient Pulses in Shock Tube . . . . .	49
6.11	Typical Calibration Curve - Wiancko Gage . . . . .	51
6.12	Q of Coil vs Frequency of Oscillator for Wiancko Gages Failing in Field . . . . .	52

TABLES

6.1	Electrical Characteristics of Several Wiancko Gages . . . . .	40
6.2	Over-Range Protection for Various Range Wiancko Gages . . . . .	41
6.3	Natural and Damped Resonant Frequencies for Various Range Wiancko Gages . . . . .	43

~~OFFICIAL USE ONLY~~  
**UNCLASSIFIED**

~~OFFICIAL USE ONLY~~

# UNCLASSIFIED

## CHAPTER 1

### INTRODUCTION AND OBJECTIVES

#### 1.1 INTRODUCTION

The Naval Ordnance Laboratory (NOL) has a long-range program to develop new atomic blast measuring equipment and to improve existing equipment. This development is directed toward improving (a) accuracy of results, (b) simplicity of fabrication, (c) versatility of field units, and (d) economy of time and money.

In conjunction with the participation of the NOL in Operation UPSHOT-KNOTHOLE, an experimental instrumentation program was undertaken by the Laboratory for the purpose of testing and evaluating new circuits, circuit components, and pressure transducers under field conditions of atomic weapons tests.

The instrumentation system used by the NOL for carrying out the primary objectives of obtaining blast data on Operation UPSHOT-KNOTHOLE, (1) consisted basically of a frequency modulating intelligence generating source, a wired transmission line, a magnetic tape recording and storage unit, and a postshot record playback and reduction set-up\*. This system was similar, though modified and improved, to the instrumentation used on Operations TUMBLER, (2) JANGLE, (3) and GREENHOUSE. (4) Throughout these various atomic weapon operations, the overall basic system had proved itself advantageous in many respects including relative freedom from extraneous electromagnetic signals, large data handling capacity, great distance allowable between measuring and recording stations, relative simplicity in field set-up and operation, reliability in remote operation, and accuracy of results.

However, room for further improvements in many of the details of the system was evident. It would be desirable, for instance, to improve: (a) the pressure gage response characteristics to obtain high frequency response (at least 2000 cps), proper damping (no "creep"

---

\*This system will be referred to in this report as the standard NOL system. Records obtained by this system will be called standard or control records.

# UNCLASSIFIED

~~OFFICIAL USE ONLY~~

or ringing) and linear transfer characteristics; (b) the compactness of the field gage-oscillator unit packaging to permit use of the same unit in different types of mounts - ground, aboveground, in structures, etc.; (c) the field installation procedure by decreasing the total quantity of transmission wire necessary; (d) the flutter characteristics of the recording and playback machines by using wider frequency deviation signals and/or flutter bucking or canceling schemes; (e) the record reduction procedure by using electromechanical or electronic data handling equipment.

## 1.2 OBJECTIVES

The scope of the program undertaken was limited to the design, development, and testing of new equipment for only those desirable improvements which required full-scale field testing before complete and final evaluation could be made. On this basis, the following four experimental instrumentation problems were undertaken: (1) the development of a transistor oscillator-amplifier circuit to function with the Wiancko gage in a field unit, (2) the modification and adaption of the commercially developed Vibrotron pressure gage and oscillator circuit, (3) the development of a sub-miniature oscillator and two wire transmission line, and (4) the design and development of a deviation multiplier circuit for flutter compensation. A fifth problem, that of determining the response characteristics of the Wiancko pressure gage, used so extensively on UPSHOT-KNOTHOLE, and evaluating its field performance, was added to this program and is reported herein.

All the experimental instrumentation tasks had a laboratory phase and a field testing phase. In the laboratory, the desired circuitry was designed, produced, and tested within the limitations imposed by the need for compatibility with the basic instrumentation system and by a stringent time schedule. In the field, the test units were disposed to provide a direct performance correlation with the main instrumentation. These experimental units, their design, performance, and evaluation are described in the following chapters.

**UNCLASSIFIED**

~~OFFICIAL USE ONLY~~

## CHAPTER 2

### TRANSISTOR OSCILLATOR-AMPLIFIER

#### 2.1 DESIGN

The transistor oscillator-amplifier field unit was designed to test the performance of transistors in circuits subject to high transient thermal and nuclear radiations, and high pressures and accelerations. Two Raytheon CK 721 p-n-p junction type transistors were used (Fig. 2.1). In the oscillator stage, transistor T1 (or tube, T1 in the vacuum tube equivalent circuit shown in Fig. 2.2) was operated essentially as a positive feedback current amplifier to produce series resonance. The variable inductance coil of the Wiancko gage served as the frequency determining element of the oscillator tank circuit. The output of the oscillator was fed to transistor T2 which operated as a grounded emitter power amplifier and buffer stage. An impedance-matching transformer coupled the output signal of this stage to a low impedance 3 mile long transmission line. The complete unit was powered from a 22-1/2 volt Minimax battery. With the oscillator operating at a center frequency of 10.7 kc, the total current requirement for the unit was 1.5 ma, and approximately 1.0 volt rms was developed across the 270 ohm load. No attempt was made to miniaturize the packaging of this experimental field unit since the transistor operational performance was the main point of investigation in this experiment.

#### 2.2 PERFORMANCE

Only one transistor unit was built. The unit was used on two shots of UPSHOT-KNOTHOLE, and in both instances this unit was within a few feet of the standard vacuum tube field unit so that direct comparison could be made of the results. On the first shot a good record was obtained from the transistor unit. This record compared very well with the adjacent standard control record as to gross qualitative and quantitative features (Fig. 2.3). However, the transistor oscillator-amplifier record showed an extraneous "hash" superimposed on the trace which was not present on the control record. The origin of this noise is not known. It appeared approximately 15-20 msec

**UNCLASSIFIED**

~~OFFICIAL USE ONLY~~

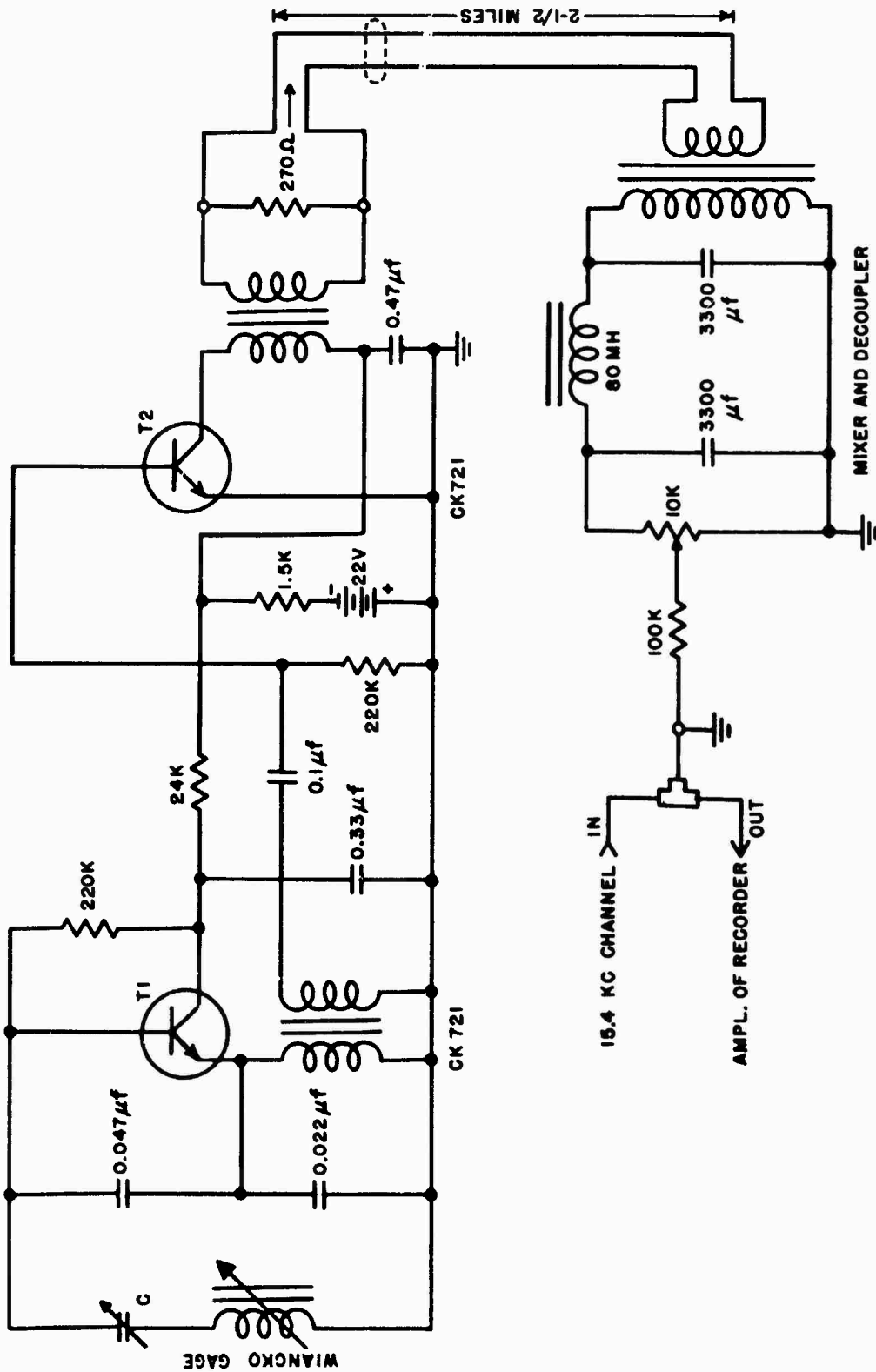

Fig 2.1 Circuit Diagram of the Transistor Oscillator-Amplifier

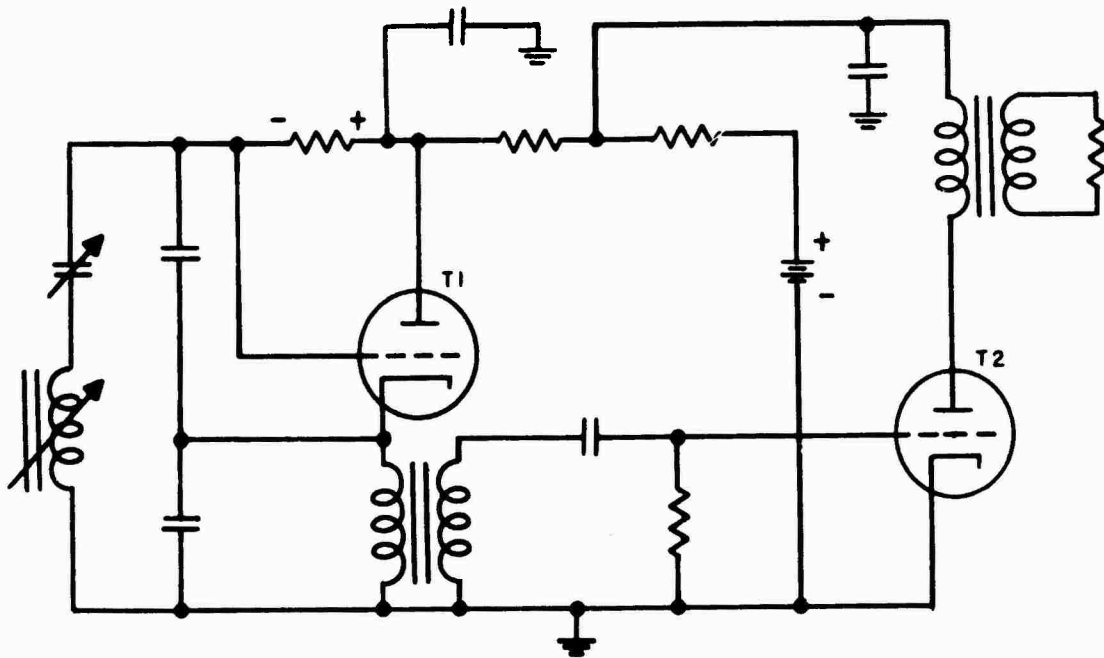
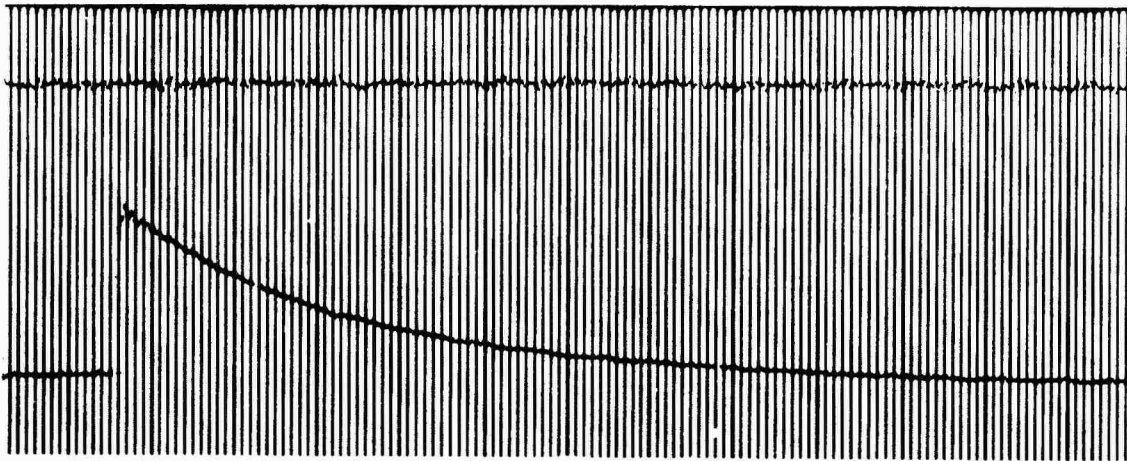

Fig. 2.2 Vacuum Tube Equivalent of The Transistor Oscillator-Amplifier

after zero time and lasted throughout the duration of the record. Its time of initial appearance coincided with an observed thermally induced shift in the gage. It may be that the transistor, although shielded by the oscillator housing, became overly hot (normal maximum operating temperature of transistors is 40°C) and thus produced noisy characteristics. However no change in transfer characteristics or excessive noise was evident in the transistor circuitry on a postshot survey. It is encouraging to note that the initial intense ionization pulse at zero time had no more effect on the transistor circuit than on the standard vacuum tube circuits. Unfortunately, the transistor unit was destroyed by the second shot and no further operational data were available.

Although no great effort was made toward optimum overall design of the experimental unit, many advantages over conventional vacuum tube circuitry were realized. The single, small, locally contained battery power source provided stable, unattended and continuous 24 hr per day operation of the unit for 14 days. This is a decided advantage over transmitting AC and DC power to the field units from large, battery driven generators over long lengths of wire. Since this power was locally supplied in the field unit, only two wires were required between the field unit and the recording unit, these wires being used exclusively for signal transmission. Thus a savings of 50 per cent was realized in wire economy over the standard conventional system where four wires were used, one pair for AC power and the other pair for the simultaneous transmission of DC power and the oscillator signal. Fewer circuit components were required by the transistor circuit than the vacuum tube circuits in general use, thus again resulting in a substantial savings in parts and ease of fabrication.



*STANDARD OSCILLATOR RECORD*

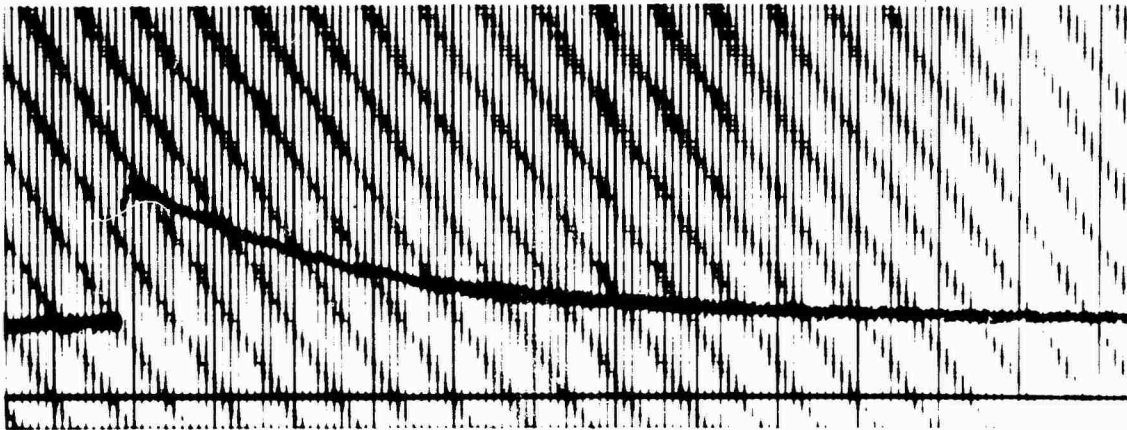

*TRANSISTOR OSCILLATOR RECORD*

Fig. 2.3 Comparison of a Transistor-Circuitry-Produced Pressure-Time Record with a Standard Record

### 2.3 CONCLUSIONS AND RECOMMENDATIONS

Based on the results of the one test, the transistor element is considered promising for atomic test instrumentation, although further development and testing should be undertaken before a complete measurement program is committed to transistor circuitry. The source of the extraneous noise should be determined and if possible, this source should be eliminated. Laboratory investigation may provide the solution to this problem; full-scale atomic testing should confirm it. Development work should be undertaken to realize the full potentialities of the advantages inherent in transistor circuitry, particularly with regard to miniaturization. A small field unit would be adaptable to a variety of mounting conditions. By proper attention to these and other details, even further over-all savings should be realized.

With the encouraging transistor circuitry performance realized and the potential advantages so readily obtainable, further investigation and development of transistor circuits should continue with high hopes of producing a serviceable field unit for atomic weapon blast measurements instrumentation.

~~OFFICIAL USE ONLY~~  
**UNCLASSIFIED**



Sylvania type 5904 triode in the Hartley oscillator stage. As in the standard unit, the Wiancko gage inductance was the frequency-determining element of the tuned circuit. Because of the low Q of the gage inductance (approximately 5-6) resistor R was inserted into the cathode circuit of the 5904 tube to improve the stability of the oscillator. The oscillator output was coupled to the grid of a pentode power amplifier tube, Sylvania type 5906. Since the plate resistance,  $r_p$ , of the pentode is large, the output circuits of several field units could be put in parallel without reduced output or excessive distortion resulting from feedback. The amplifier as used developed 50 volts rms across the 220 ohm line with a total harmonic distortion of less than 3 per cent. (The distortion figure can be reduced to 1 per cent with a slight reduction in output voltage by adding a 1 megohm resistor between the plate and grid of the pentode to provide a small amount of negative feedback.)

The 26 volt filaments of the two tubes were put in series, and this series arrangement was placed in parallel with the plate of the oscillator tube which required 55 volts DC. By thus utilizing the DC plate source for the filament power source also, the need for AC power at the field unit was circumvented and it became a simple task to simultaneously transmit the required DC power and the oscillator-amplifier signal over the same pair of leads. The total DC current drawn from the unit was approximately 60 milliamperes at 300V DC.

The sub-miniature size of the tubes and the elimination of the need for a filament transformer, materially helped in producing a small, compact field unit. A further saving in space and components was realized in the elimination of the bridge network required when signals from several standard low  $r_p$  triode output units were mixed. By careful design, the complete field unit - gage and oscillator-amplifier - was housed in an aluminum cylinder 3 in. in diameter and 6 in. long (Fig. 3.2), making the unit easily adaptable for installation in structures, aboveground baffles, and ground mounts. The unit was made relatively free from detrimental environmental conditions such as dust, temperature variations, and water by the use of "O" ring seals. An attempt was made to dissipate heat uniformly within the unit so as to obtain stable oscillator performance independent of ambient field temperatures. This was done by wrapping each tube in crinkled aluminum foil so that an uninterrupted thermal conductive (rather than convective) path was provided from the tube to the metal housing.

### 3.2 PERFORMANCE

Two experimental sub-miniature field units were built for testing on this operation. Each was used on two shots. The outputs of the two units, operating at center frequencies of 15.4 kc and 10.7 kc respectively, were dplexed and transmitted back to the recording units over approximately 2-1/2 miles of unshielded telephone wire (Signal Corps wire WD-1/TT).

Both units functioned properly on both shots. The records obtained from these units were indistinguishable from the control records

~~OFFICIAL USE ONLY~~  
**UNCLASSIFIED**



Fig. 3.2 Sub-Miniature Two-Wire Oscillator-Amplifier  
and Gage Field Unit

produced by the standard field units. A minor deficiency was observed in preshot operation of the oscillator: the center frequency of the experimental units varied with changes in ambient temperature to a greater extent than the standard oscillator unit center frequency. A relocation of parts or the selection of temperature compensating electronic components should ease this problem.

### 3.3 CONCLUSIONS AND RECOMMENDATIONS

The sub-miniature two-wire oscillator-amplifier field unit proved successful. Except for the slightly excessive temperature sensitivity, the desired goals were reached - a small sealed package adaptable to many field installations, a reduction in the number of electronic components, and the use of only two wires between the field unit and the power and recording station. The design of this experimental unit will certainly serve as the basis for new oscillators for the NOL FM system when new oscillators are warranted; however, for the present at least this unit will be limited in its field application to those situations where signals are at most diplexed because of the limited power supply capacity of the present NOL instrumentation trailers.

## CHAPTER 4

### VIBROTRON GAGE AND AMPLIFIER

#### 4.1 DESIGN

The Vibrotron gage and amplifier, a commercially available product of the Byron Jackson Co., derives its principal potential advantages from the gage design itself. The gage offers high frequency response, linear transfer characteristics, and wide frequency deviation for application in an FM system. The sensing element of the gage consists of a vibrating wire, 0.4 mil tungsten, held in tension between a fixed tie point and a pressure sensitive diaphragm. The length and tension of the wire determine its vibrating frequency, and its mode of vibration is controlled by a magnetic field directed perpendicular to the wire. The gage is part of a bridge circuit which derives its energy from the 6BA6-12AT7 positive feedback voltage amplifier (Fig. 4.1). Pressure on the diaphragm changes the length and tension of the wire, altering its vibration frequency accordingly, and thus providing a frequency modulated signal. This signal from the Bridge amplifier is then fed to the remaining half of the 12AT7 output amplifier. A portion of the output is rectified and used as the bias for the bridge amplifier thus making the circuit stability practically independent of plate supply variations.

In order to use the Vibrotron gage and amplifier unit with the NOL system, slight modifications to the unit were required as shown in Fig. 4.2. The power amplifier stage was added to match the high impedance output of the 12AT7 to the 270 ohm line, and this stage served in the additional capacity of a buffer amplifier permitting the paralleling of two signals into a common load without undue intermodulation between these signals.

Three Vibrotron units were purchased and adapted for the testing program. Two units were operated at a center frequency of approximately 15.4 kc; the third unit was operated at 7.7 kc. The frequency response of the gage and amplifier was approximately 3 kc. A design figure of  $\pm 20$  per cent frequency deviation at nominal pressure range was realized on two units; the third unit was operated at  $\pm 30$  per cent frequency deviation at nominal pressure range.

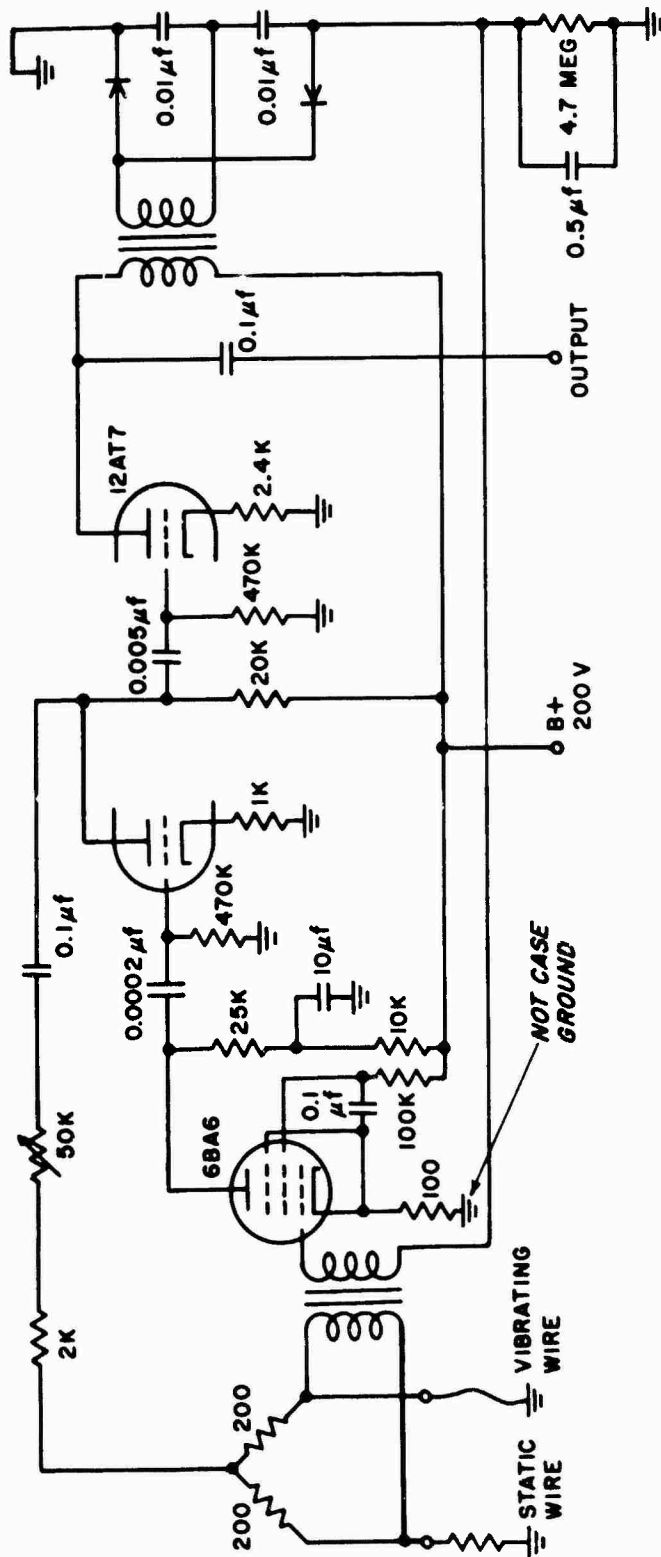
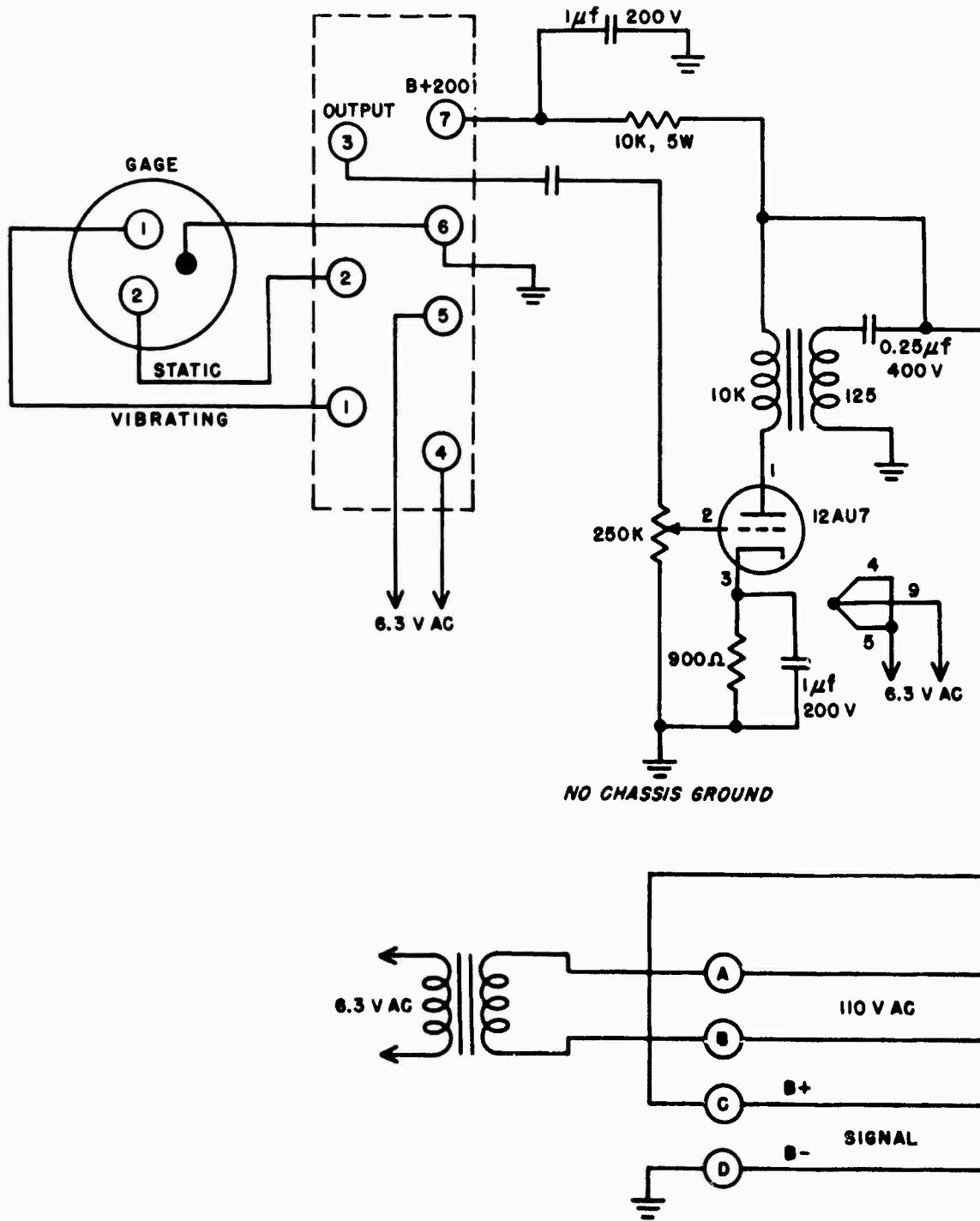

Fig. 4.1 Circuit Diagram of the Vibrotron Gage and Oscillator

**UNCLASSIFIED**



- Fig. 4.2 Circuit Diagram of the Vibrotron Line Amplifier

~~OFFICIAL USE ONLY~~  
**UNCLASSIFIED**

## 4.2 PERFORMANCE

Three units were tested on two shots; however, only one record was obtained. This record (Fig. 4.3) shows excessive hash and transient signals superimposed on the carrier. The source of these transient pulses and hash is not definitely known. However, preshot operation of the Vibrotron units indicated that circuit stability was a marked function of the level of positive feedback to the gage, and the feedback adjustment was a delicate one. Too much feedback resulted in spurious oscillations and distorted waveforms. Further, it was later established that the electronics of the Vibrotron unit would not respond satisfactorily to an excitation pulse with frequency components greater than 3 kc; i.e., the unit would block.

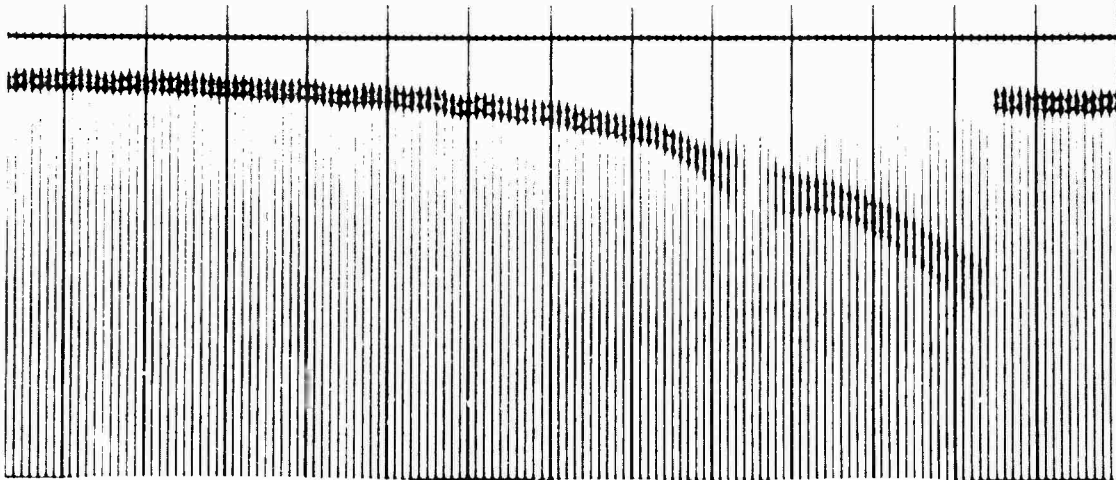

Fig. 4.3 Vibrotron Gage and Amplifier Pressure-Time Record

Although the one record follows, in general, the control record pressure-time history, the ease and accuracy of determining such features of the shock waves as peak pressure and duration of pulse is poor.

Records were not obtained from the other two units because of gage failure. A postshot examination of these gages showed the vibrating wires to be broken at the tie point. Since the signals from both these units stopped at zero time, it is possible that the gage tension wires broke at this time. The intense thermal flux at zero time may have expanded the diaphragm sufficiently to strain the wire beyond the limit of the tie point. The accuracy of this hypothesis is questionable, however, since it could be expected that some small time would be required for the diaphragm to react to the thermal energy and no such delay is evidenced between zero time and gage failure. Thus, although the exact cause of gage failure is not determined, it definitely is associated with some phase of the explosion.

#### 4.3 CONCLUSIONS AND RECOMMENDATIONS

On the basis of the field operational tests performed on the Vibrotron units, it is concluded that the Vibrotron gages and amplifiers as used on UPSHOT-KNOTHOLE are unsuitable for use in applications of this type. They are unstable in operation, insufficiently rugged for field operation, and require excessive care in adjustment. Further development work may overcome the existing deficiencies of the units and make available the full potentialities of the basically sound principle of the vibrating wire gage.

## CHAPTER 5

### DEVIATION MULTIPLIER

#### 5.1 INTRODUCTION

The dynamic range of a measuring system is determined, to a large extent, by the inherent noise level of the system. In general, it is desirable to have a low noise level and a large signal; i.e., a large signal-to-noise ratio. The deviation multiplier unit is a circuit designed to increase the signal-to-noise ratio by increasing the signal frequency deviation obtained from a transducer.

In the NOL FM system using magnetic tape recorders and reproducers, the inherent system noise is introduced principally by the tape handling machines in the form of a frequency modulating flutter. This flutter noise is of a fixed value equal to 0.15 per cent of the frequency recorded on the tape. For a full scale (nominal) pressure signal a frequency deviation of 7.5 per cent of the oscillator center frequency is realized for the signal. The signal to noise ratio is then  $\frac{7.5}{0.15}$

or 50:1. However, if a signal deviation of only 1.0 per cent is realized, the signal-to-noise ratio becomes  $\frac{1.0}{0.15}$  or approximately 7:1,

which value becomes marginal for required accuracies and desired ease of reading records. The deviation multiplier receives this low level signal (or any signal) and effectively increases the frequency deviation by a factor of approximately 3, and thus increases the signal-to-noise ratio by the same factor, which makes it an acceptable value. (In the above example, the deviation multiplier would increase the 1 per cent frequency deviation to 3 per cent and the signal-to-noise ratio would be  $\frac{3}{0.15} = 20:1$ .) It is obvious that since it is the tape handling

machines that introduce the flutter noise, the signal deviation should be large on the tape; therefore, the deviation multiplier unit is inserted into the system between the gage produced FM signal and the recording amplifiers.

#### 5.2 DESIGN

### 5.2.1 General

The deviation multiplier unit contained two channels, one for use with a 15.4 kc input signal, and the other for use with a 10.7 kc input signal. Slightly different methods were used in each channel to provide the increase in deviation. This was required in order to prevent intermodulation between the frequencies of the two channels and to allow the diplexing of recorded signals.

In the 15.4 kc channel (Fig. 5.1) the input signal with its modulation was quadrupled. For example, a 15.4 kc signal with a  $\pm 4$  per cent frequency deviation modulation (15,400 cps  $\pm$  616 cps) is converted into 61.6 kc  $\pm 4$  per cent (61,600 cps  $\pm$  2464 cps). This signal is then heterodyned with the output of a fixed 43 kc local oscillator. By suitable filtering, the difference frequencies only are fed to the tape recorder. These frequencies are 18,600  $\pm$  2464 cps or 18.6 kc  $\pm$  13.2 per cent. Thus the unit has effectively multiplied the original signal deviation of 616 cps or  $\frac{4}{100}$  per cent to 2464 cps or 13.2 per cent; the signal deviation has been increased by a factor of  $\frac{13.2}{4} = 3.3$ . Since the flutter value for the tape machine is a constant

0.15 per cent, the signal-to-noise ratio is increased by a factor of 3.3.

In the 10.7 kc channel, the input signal with its modulation signal is mixed directly with the signal from a 7.6 kc heterodyning oscillator. A low pass filter following the mixer removes all but the difference frequencies and passes them on to the amplifier of the tape recorder. As an example, a 10.7 kc input signal with a  $\pm 4$  per cent modulation (10,700  $\pm$  428 cps) is mixed with the fixed 7.6 kc frequency of the local oscillator. The difference frequencies are 3.1 kc  $\pm$  428 cps or 3.1 kc  $\pm$  13.8 per cent. Thus the signal frequency deviation being recorded on the tape has been increased from  $\frac{4}{100}$  per cent to 13.8 per cent, or by a factor of  $\frac{13.8}{4} = 3.45$ . With the noise

remaining constant at 0.15 per cent, the effective signal-to-noise ratio has been increased by the same factor: 3.45.

Thus, for both input signals, wide frequency deviation is obtained. It is to be noted that the 15.4 kc input signal with its modulation is recorded as an 18.6 kc signal with increased modulation deviation, and the 10.7 kc plus modulation input signal is recorded as a 3.1 kc signal also with increased modulation deviation. This separation of recorded signal frequencies was sufficient to permit diplexing on a common recorder head without undue intermodulation between signals.

### 5.2.2 Circuit

A brief description of the deviation multiplier circuit (Fig. 5.2) follows: The diplexed signal frequencies, 15.4 and 10.7 kc, from the field units enter the input cathode follower stages, T<sub>1</sub> and T<sub>2</sub>, of the two channels. These low impedance output stages provide adequate signal to the channel band pass filters. The filtered 15.4 kc signal

~~CONFIDENTIAL~~  
**UNCLASSIFIED**

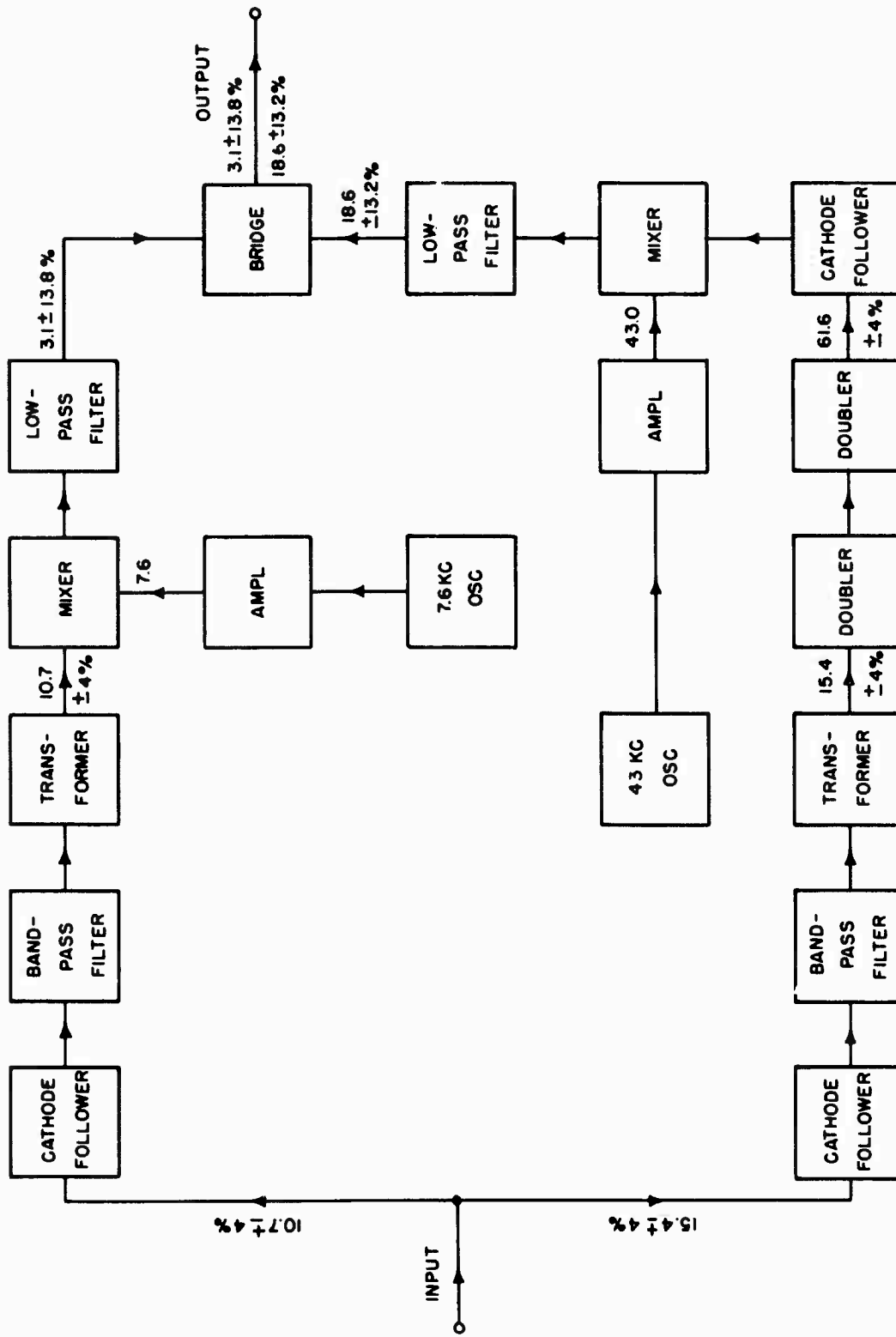

Fig. 5.1 Block Diagram of the Deviation Multiplier

~~OFFICIAL USE ONLY~~  
**UNCLASSIFIED**

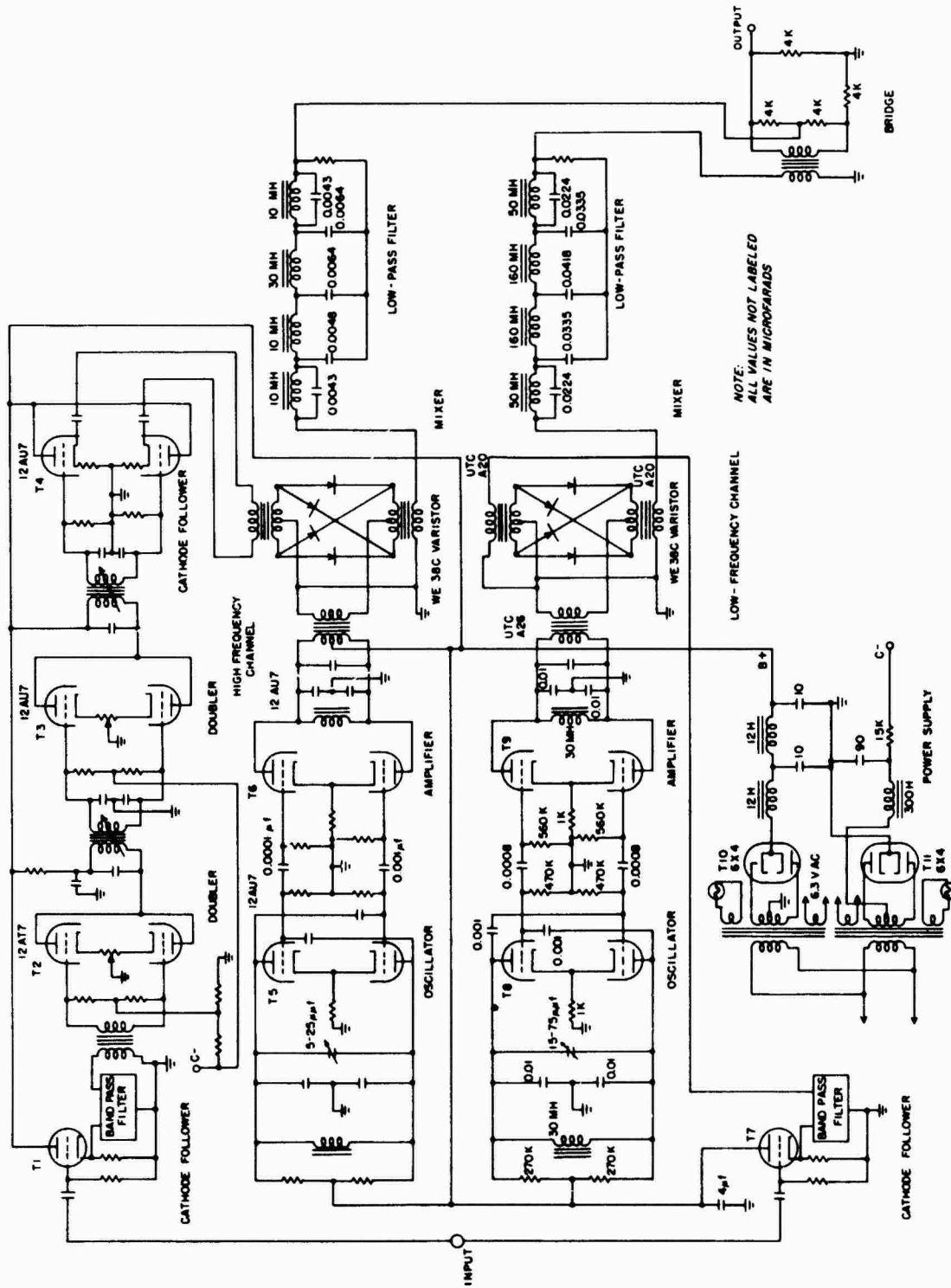

Fig. 5.2 Circuit Diagram of the Deviation Multiplier

OFFICIAL USE ONLY  
UNCLASSIFIED

is then transformer matched to a broad tuned frequency doubler, T<sub>2</sub>. The output is then doubled again in T<sub>3</sub>. The two doublers increase the input 15.4 kc signal frequency to 61.6 kc and are operated push-push Class B to minimize harmonic distortion. An output cathode follower stage, T<sub>4</sub>, matches the high impedance output to a 2000 ohm balanced modulator type varistor mixer. The heterodyning 43 kc oscillator T<sub>5</sub>, is followed by a tuned amplifier, T<sub>6</sub>, operated Class A. This push-pull amplifier was designed to reduce harmonic distortion and to provide sufficient output voltage at a low impedance to effect efficient mixing. A high ratio of oscillator voltage to signal voltage is necessary for efficient mixing. The output of the amplifier is transformer coupled to the non-linear varistor mixing stage where sum and difference frequencies are produced. The difference frequencies (18.6 kc + modulation) are passed on through the low pass filter following the mixer and are linearly combined with the output of the 10.7 kc channel in the resistance bridge circuit.

The 10.7 kc signal input after filtering is fed directly to another varistor mixer. The signal from the local heterodyning oscillator, T<sub>8</sub>, operating at 7.6 kc is amplified by T<sub>1</sub> and fed to this same mixer stage. The difference frequencies produced (3.1 kc + modulation) pass through the low pass filter to the resistance bridge and combine with the 18.1 kc signal from the high frequency channel. The output of the bridge is fed directly to the recording amplifiers.

A total input signal of 1 volt rms results in an output of approximately 0.5 volts rms - quite adequate to drive the recording amplifiers.

### 5.3 PERFORMANCE

One deviation multiplier unit (Fig. 5.3) was constructed and used on two shots. Excellent results were obtained, (Fig. 5.4), and the designed increase of signal-to-noise ratio was realized in the field. The records are noise-free (the width of the trace is limited by the spot size of the galvanometers) and follow in detail the pressure variations of the control records. Without question, the records obtained by use of the deviation multiplier are superior to the standard records, and they can be read with greater ease and accuracy.

The one disadvantage of the unit is its complexity. Extreme care was taken to minimize the production of extraneous frequencies within the unit and to properly channel the desired frequencies through the various stages. This resulted in the inclusion of many filter circuits and optimally designed linear amplifiers. (It was found in the deviation multiplier units used on GREENHOUSE (4) that where insufficient signal level and poor filtering occurred simultaneously, the deviation multiplier introduced more "noise" into the system than was compensated for by the wide signal deviation obtained.) The further requirement for diplexing resulted in the additional complexity of frequency doublers and still more filters.

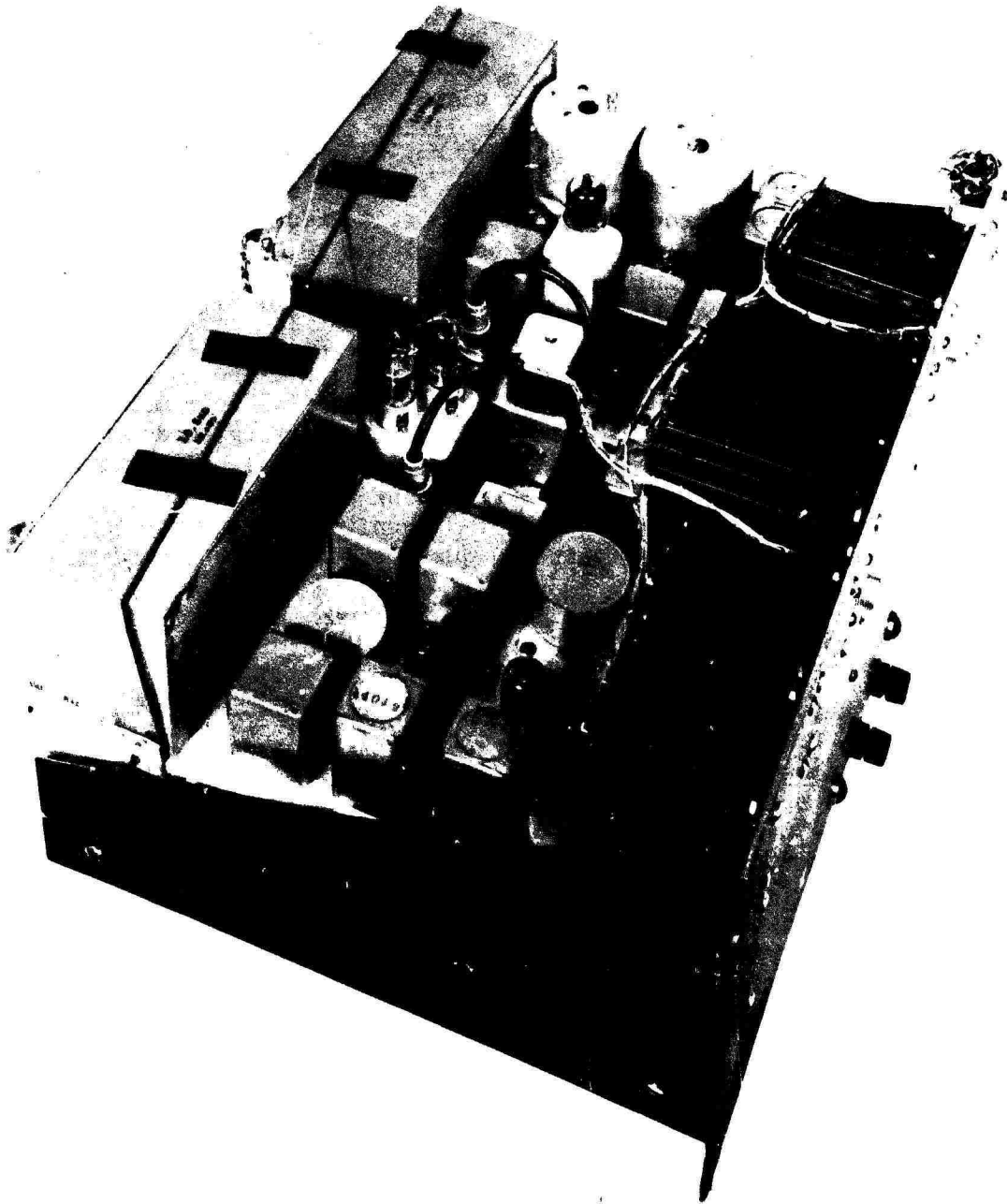

Fig. 5.3 Deviation Multiplier Unit



Fig. 5.4 Pressure-Time Record Produced by the Deviation-Multiplier System

#### 5.4 CONCLUSIONS AND RECOMMENDATIONS

It is believed that more developmental work on the unit will produce a simpler unit, particularly if single channel operation is adequate. The complexity of the unit, however, must be weighed against the results obtained. In situations that may arise where extremely low noise is a prime requirement, the deviation multiplier would provide the means for realizing this requirement.

## CHAPTER 6

### THE WIANCKO PRESSURE GAGE

#### 6.1 INTRODUCTION

##### 6.1.1 General

In the selection of a transducer for measuring pressure phenomena there are two important questions which must be considered; namely, what type of pressure phenomenon is to be measured, and what recording system is to be used to transform the pressure-induced signals into a usable record. In the present application, the pressure phenomenon to be measured was that of shock pressure-time histories resulting from large-scale explosions, and the recording was to be accomplished by an FM signal generation system. (1) Thus the transducer had to have the ability to change a pressure signal from an atomic blast into an electrical output which could in turn be used to modulate the FM carrier frequency.

##### 6.1.2 Gage Requirements

The above requirements for a transducer could be met by the use of a variable reluctance type transducer whose variation in inductance modulates the center frequency of a Hartley oscillator, thus giving a frequency variation which is a function of the applied pressure. For a nominal 20 KT bomb, a frequency response of 1000 cps would give results of 1 per cent accuracy for a critically damped system. Thus the transducer should have a frequency response of this order.

#### 6.2 THE WIANCKO PRESSURE GAGE

##### 6.2.1 General Description

The preceding electrical and mechanical characteristics along with temperature stability, accuracy, simplicity of operation, ruggedness, and compactness led to the selection of a transducer (Fig. 6.1) of the PAD type (now the 1400 series) manufactured by the Wiancko Engineering Co. and modified by the manufacturer to fit the specific



(a) WIANCKO PRESSURE GAGE

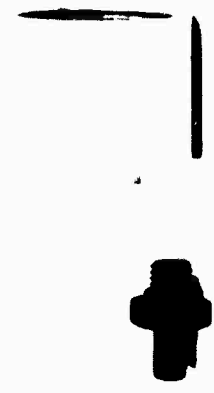
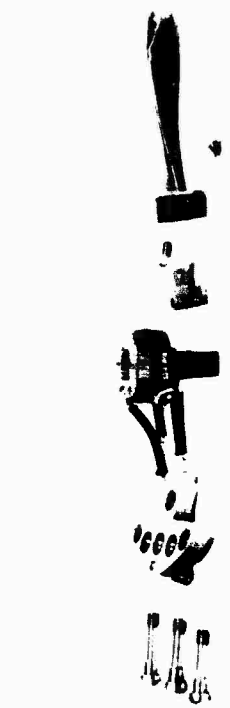

(b) WIANCKO PRESSURE GAGE - EXPLODED VIEW

Fig. 6.1 Wiancko Pressure Gage

requirements of NOL.

The sensing element (Fig. 6.2), in the Wiancko pressure pickup consists of a flat twisted tube which, when excited by an internal pressure, moves in torsion causing the armature (Mu-metal pad) above the E core to rotate and change the inductance of the gage. The rotation is directly analogous to the straightening out of a bourdon tube. The rotation of the armature is approximately 1 degree for the normal rated range of the gage and the desired electrical sensitivity is obtained by changing the initial spacing between the armature and the E core.

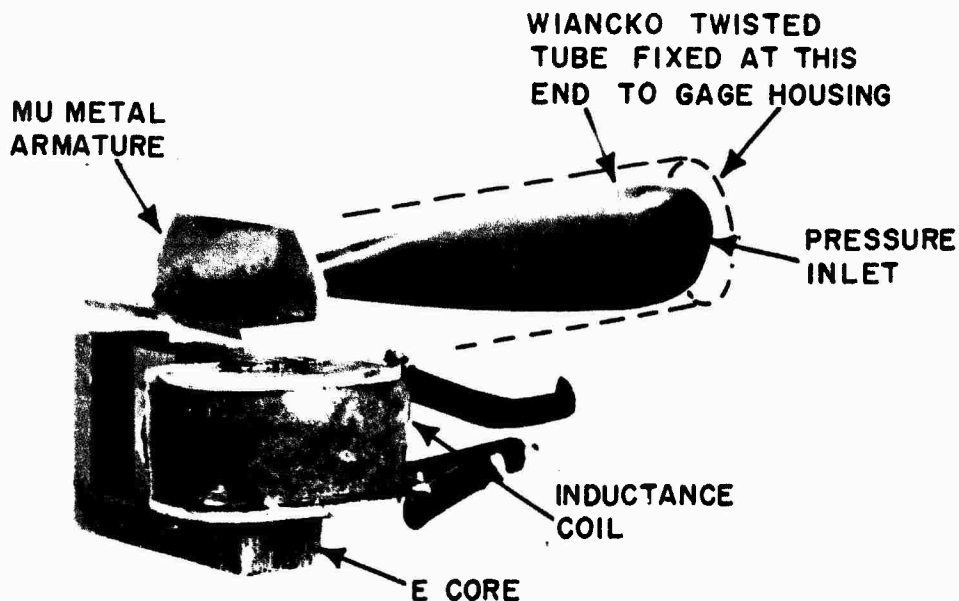

Fig. 6.2 Wiancko Pressure Gage Sensing Element

The gages were equipped with an adjustable "bleed plug" to equalize the pressure in the instrument case as the ambient temperature and barometric pressure changed. These gages also could be used as a differential pressure gage if the need arose.

#### 6.2.2 Design Specifications

As the electrical coil configuration in the majority of Wiancko pickups had been designed for use as the two active arms of an inductance bridge, a slight modification had to be made so that the gage could be used in a Hartley oscillator circuit. One coil was removed and a single coil was used with the following electrical specifications:

Inductance:            Approximately 120 millihenries, with  
                                 a 40 per cent tap, turnwise.

Resistance: Approximately 100 ohms (DC).

Q Minimum 4.5 at 14.5 kc.

It was felt that the desired mechanical properties of the gage should be those listed below:

Deviation 8 to 9 per cent of rated range on 10 psi gage and higher with a minimum of 160 per cent over-range protection. Minimum of 7.5 per cent of rated range on 5 psi gage with minimum of 135 per cent over-range protection.

Rise Time Less than 0.3 msec.

Damping 0.6 to 0.7 critical at 75°F.

Hysteresis 0.8 per cent of bandwidth.

Linearity Not greater than 10 per cent non-linearity over indicated usable range.

Acceleration Effect 0.01 to 0.05 per cent per G.

Temperature Effect 0.02 per cent of pressure per degree Fahrenheit (-25°F to 180°F).

Because of the close time schedule involved and the dependence of mechanical properties on electrical qualities, a compromise discussed subsequently had to be reached with the manufacturer.

### 6.3 ELECTRICAL CHARACTERISTICS

#### 6.3.1 Q of Coil

The frequency stability of the modified Hartley oscillator (1) used with this gage is dependent on having a gage coil with as large a Q as possible. The frequency stability of the oscillator approached 30 parts per million per volt at a frequency of 14.5 kc when the Q was greater than 5; however, the oscillator failed to function if the Q of the coil were below 2. The low Q of the coils in the standard pickups was one of the most serious problems which the manufacturer had to overcome.

As the lack of time prohibited the extensive redesign of the E-core, the Q was improved slightly by using thinner laminations and by increasing the size of the Mu-metal armature. Figure 6.3 shows a plot of Q vs frequency for a typical 5 psi gage and a typical 10 psi gage. It was noted that the Q's of the 5 psi gages were lower than the Q's of the 10 psi and above range gages. This was due to the fact that the spacing between the E-core and Mu-metal armature was less in

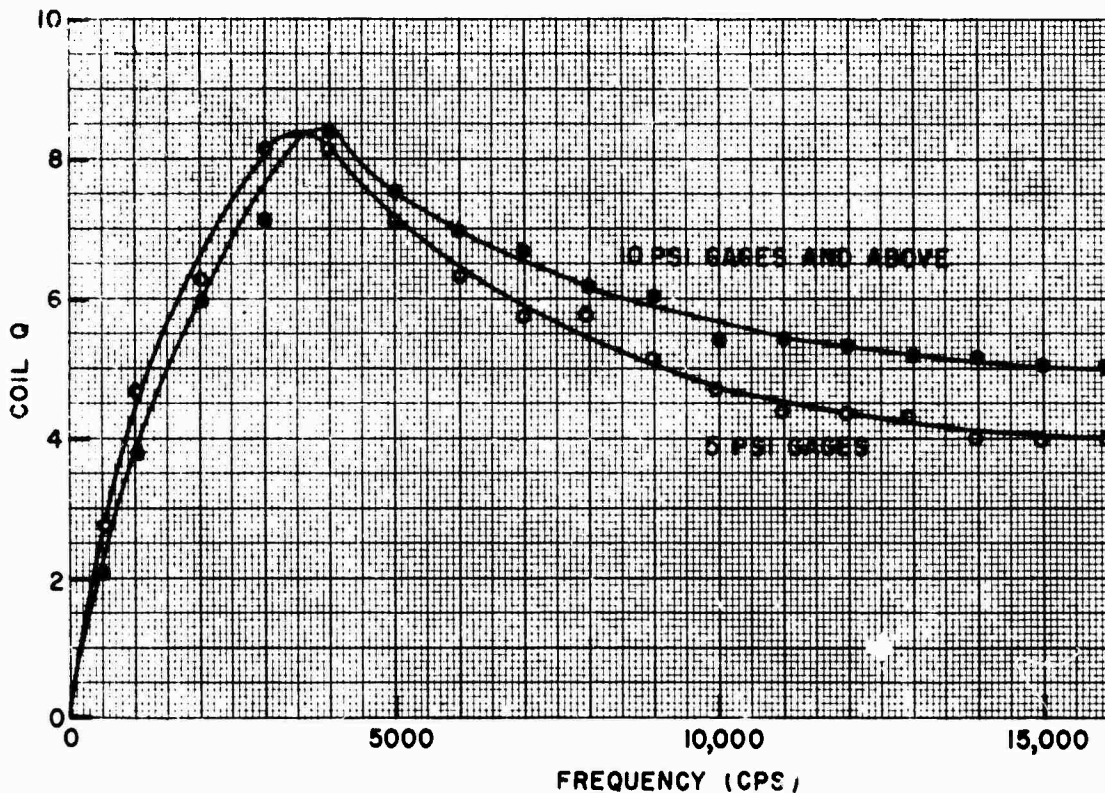

Fig. 6.3 Q of Coil vs Frequency of Oscillator - Wiancko Gage

the case of the 5 psi gages. As the 5 psi gages have the same size twisted tube, it was necessary to close the gap to 5 mils to get the 7.5 per cent minimum deviation required. Figure 6.4 shows that as the gap between the E-core and Mu-metal becomes smaller by the application of pressure to the gage, the Q changes slightly.

In Table 6.1 are listed the various electrical characteristics of a few typical gages.

TABLE 6.1 Electrical Characteristics of Several Wiancko Gages

Gage No.	Range psi	DC Resistance ohms	Inductance mh	Q at 14.5 kc
9887	+ 5 to -2	140	105	4.0
9979	+ 5 to -2	141	107	4.1
11533	+ 10 to -4	136	85	4.9
11549	+ 15 to -6	146	85	5.1

### 6.3.2 Frequency Deviation

It has been pointed out (1) that larger signals in a magnetic tape recording system would produce an increased signal to "wow-and-

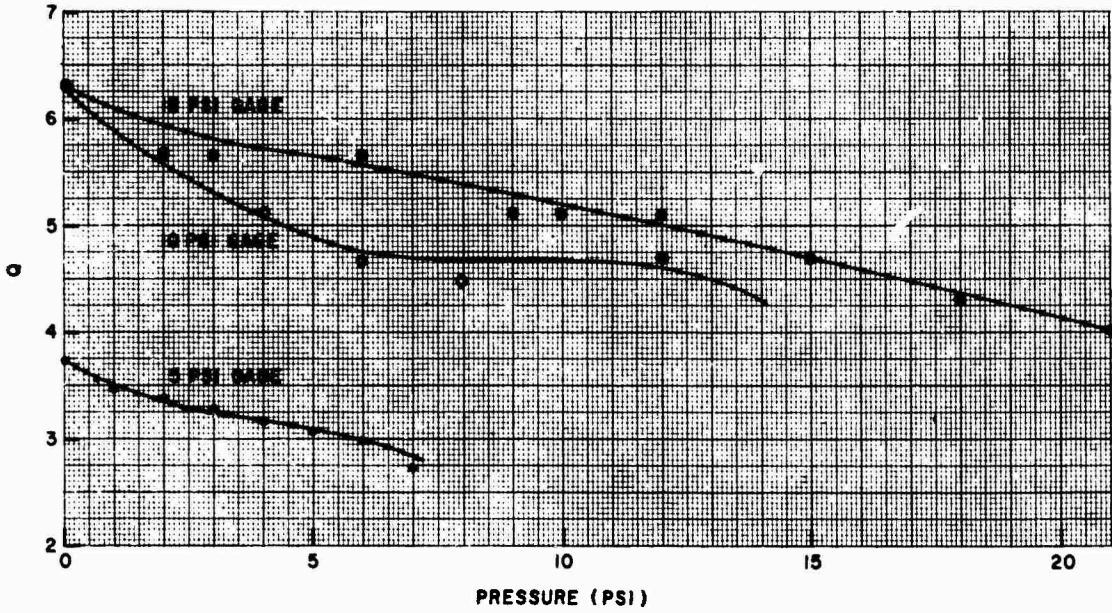

Fig. 6.4 Q of Coil vs Pressure - Wiancko Gage

flutter" induced noise ratio. Therefore, greater deviation was sought with this gage than had been previously obtained with the Bendix gage used on TUMBLER. (2) To produce greater deviation the gap between the E-core and Mu-metal armature was decreased to about 12 mils on 10 psi range gages and above. However, as the spacing is decreased, the over-range protection of the gage is lost. As the predicted values of the pressures to be measured were accurate to + 20 per cent, a 160 per cent over-range protection was more than sufficient. For a gage having a frequency deviation between 8 and 9 per cent for its rated range, the over-range protection pressure would result in a frequency deviation between 14 and 16 per cent. Table 6.2 shows the range of gages used and their average over-range protection.

TABLE 6.2 Over-Range Protection for Various Range Wiancko Gages

Nominal Gage Range (psi)	Actual Gage Range (psi)	Nominal Gage Range (psi)	Actual Gage Range (psi)
5	-2 to + 7	30	-10 to + 48
10	-4 to +16	60	-14 to + 96
15	-6 to +24	100	-14 to +160
20	-8 to +32	300	-14 to +480

As the gap spacing on the 5 psi gages was 5 mils, its over-range protection was slightly less (140 per cent) than that of the other gages.

## 6.4 MECHANICAL CHARACTERISTICS

### 6.4.1 Frequency Response

The maximum frequency response that can be obtained from any spring-mass system depends on the natural undamped frequency of the system. Assuming that the gage has a natural frequency of 1000 cps, the minimum rise time that can be expected is 0.5 msec. If we consider the motion of the Wiancko twisted tube and armature as having only a torsional rotation, the motion approaches that of a simple torsional pendulum whose frequency is given by the following equation:

$$f = \frac{1}{2\pi} \sqrt{\frac{k}{I}}$$

where k is the spring constant of the twisted tube and I is the moment of inertia of the armature about the center of rotation of the tube. (The mass of the armature is accounted for, in part, by the k factor.) As k is inversely proportional to the length of the tube and I directly proportional to the mass of the armature, higher natural frequencies can be obtained by using a shorter twisted tube and an armature of less mass.

A variable frequency audio oscillator was applied to the coil of the gage and the frequency varied until the audio signal induced a vibration in the undamped armature. Four modes of oscillation (Fig. 6.5) were observed at different resonant frequencies. A strobotac was used to check the mode of oscillation, and in most cases it was observed that the armature was oscillating at the second harmonic of the driving frequency.

The most easily excited mode of vibration, a rotational oscillation of the armature, was considered the natural mode of oscillation of the gage (Fig. 6.5a). This torsional mode was excited in all gages selected and was considered the mode of oscillation produced when a damped gage was subjected to a step-pressure function. As the twisted tube is joined to the main gage frame only at one end, the armature and tube can behave as a loaded cantilever beam. The three cantilever vibrations which were most predominant were oscillations in the plane of the armature (Fig. 6.5b), oscillations at right angles to the plane formed by the armature and twisted tube (Fig. 6.5c), and oscillations in a plane rotated 45° from the armature plane (Fig. 6.5d).

The three different cantilever modes were not excited in all gages selected. Table 6.3 lists the natural undamped cantilever and torsional frequencies for various range gages. It also lists the ring frequency of the gages that have been damped for use in the field. As expected, this frequency is slightly less than the natural undamped torsional frequency. These natural undamped frequencies are considerably lower than those reported by Vulgan (6) for a similar gage. It is believed that this difference in frequency is due to the increased mass of the armature used in the gage modified for the NOL.

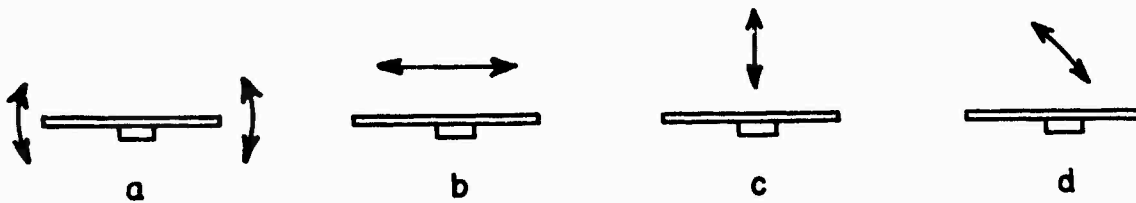

Fig. 6.5 Modes of Vibration in the Wiancko Gage

TABLE 6.3 Natural and Damped Resonant Frequencies  
For Various Range Wiancko Gages

Nominal Gage Range (psi)	Frequency (cps)				
	Undamped				Damped
	Mode B*	Mode C*	Mode D*	(Mode A)* Torsional	Torsional
5 and 10	248	789	347	821	790
15	-	880	-	950	866
20	-	885	-	1076	1048
30	-	388	652	1148	1130
60	680	1265	-	1650	1621
100	930	650	-	1859	1840

\* See Fig. 6.5 for definitions of various modes.

#### 6.4.2 Damping

The gages which were originally received from the manufacturer were damped 0.6 to 0.7 of critical at a temperature of 75°F. It was found that this type of damping produced a considerable amount of drag-out or "creep" when the gage was excited by a step pressure function. Creep is defined as the failure of the gage to reach its steady-state value in the time that it takes the transient response oscillations to die out. Figure 6.6 is the transient response of a 10 psi gage to a step pressure from the NOL pressure pot. (7) The creep effect is quite apparent as the gage does not reach the steady-state pressure for more than 10 msec.

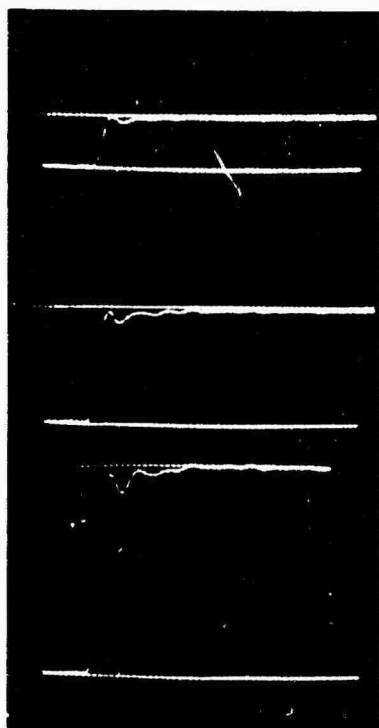

5 PSI STEP PRESSURE

10 PSI STEP PRESSURE

14 PSI STEP PRESSURE  
(2 Kc TIMING FREQUENCY)

Fig. 6.6 Dynamic Response of the Wiancko Gage Showing Creep

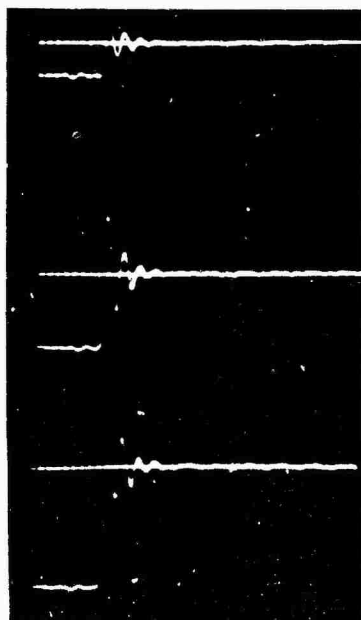

5 PSI STEP PRESSURE

10 PSI STEP PRESSURE

14 PSI STEP PRESSURE  
(2 Kc TIMING FREQUENCY)

Fig. 6.7 Dynamic Response of the Wiancko Gage with  
Optimum Damping

44  
~~SECRET~~  
**UNCLASSIFIED**

Various parameters of the damping mechanism were changed in an effort to overcome this drag-out. Normally, a drop of silicone grease was placed between a fixed damping bar and the armature to provide damping. Several damping greases and mixtures were tried. The length and width of the damping-bar were changed. The spacing between the damping bar and armature was varied, as well as bending the bar so that the spacing was not uniform. Grease was even placed between the armature (Fig. 6.2) and the center section of the E-core.

On the basis of later investigations on the acceleration sensitivity of the Wiancko gage (see sect 6.4.3), and with the observation of cantilever modes of vibration for the twisted tube, a probable explanation for creep occurs. The 0.6 to 0.7 of critical damping that is desired for the high frequency torsional motion of the armature results in a greatly overdamped condition for the low frequency cantilever motion. When the gage is pressure excited, not only does torsional motion of the armature result, but also a cantilever action. The overdamped cantilever mode thus gives the creep effect. However, because time did not permit a detailed study of the effects of damping on the complex modes of vibration of the armature prior to the operation, a compromise had to be reached. By letting the gage ring for 3 to 5 msec with 0.2 and 0.3 of critical damping, the creep effect was overcome and still the ringing or "overshoot" of the gage did not hinder unduly the reading of the record. It was felt that records with a little ring were better for reading peak pressures from a shock wave than records where the gage had been critically damped and creep appeared.

Each gage received from the manufacturer was redamped using Dow Corning No. 33 "fluid type" low temperature grease and the damping bar spacing adjusted by trial and error to obtain the desired result. This spacing varied between 0.005 in. and 0.015 in. and in some cases the damping bar was bent up slightly at its ends. Transient responses of a properly damped gage are shown in Fig. 6.7. It was also observed that with 0.2 of critical damping the hysteresis or failure of the gage to return to zero promptly was considerably reduced.

#### 6.4.3 Acceleration Sensitivity

Upon the conclusion of UPSHOT-KNOTHOLE, it was felt that some of the pressure-time records exhibited an undue amount of ring for a properly damped gage.\* As this gage had been modified by increasing the size of the Mu-metal armature and using it in a single ended magnetic circuit, perhaps an acceleration effect was being observed on the pressure-time record. Previously, Shreve (6) had likewise noted acceleration-like effects with the standard light armature balanced Wiancko gage. An extensive investigation was undertaken to see what the acceleration effects were for this NOL modified gage.

Two methods were used to observe this effect. First the gage was placed on a variable frequency shake table of the acceleration

\* For a more complete discussion of the acceleration sensitivity of the gage and its effect on UPSHOT-KNOTHOLE records see References (1) and (8).

**UNCLASSIFIED**

~~CONFIDENTIAL~~

type. The plane formed by the Mu-metal pad and the twisted tube was perpendicular to the mode of vibration. This is the most sensitive position for producing a change in the reluctance of the coil. By varying the frequency and the magnitude of the acceleration, any noticeable effect in the output of the oscillator circuit was recorded. The second method used subjected the gage to a drop test. Here the gage was subjected to an average acceleration upon impact varying from 7G to 30G for a duration of 10 msec.

The results from the vibration test were reduced to a common base and the acceleration effect in per cent of nominal gage range per G was plotted against the frequency of vibration (Fig. 6.8). A considerable acceleration effect was noticed when the frequencies of vibration were those of the resonant undamped cantilever frequencies (see Table 6.3). The results of the drop test are shown in Fig. 6.9. No effect was noticed at 1G acceleration and it was assumed that over the ranges of acceleration investigated that the effect was linear.

From the above results, it is apparent that the gages are acceleration sensitive. However, it appears that accelerations of short duration and low magnitude do not excite the gages. Therefore, caution must be used in saying that extraneous variations on pressure-time records are the results of acceleration effects.

To help clarify this situation, a gage, oscillator, and cover plate were subjected to a shock wave from the NOL shock tube by placing the combination, face on, at the end of the tube. The lower response picture in Fig. 6.10 represents the output of the gage for a step pressure function from the shock tube of approximately 10 psi. In an attempt to isolate the step pressure pulse from a step acceleration pulse, the step pressure pulse was changed to a slow-rise pressure pulse by means of a long-time constant orifice to the gage. The upper wave form is the gage response to this slow rising pressure function of about 5 msec rise time. The periodic oscillation superimposed on the slowly rising pressure function has the same frequency as the damped ring frequency of the gage. (This same ring frequency was reproduced when the oscillator-gage assembly was given a sharp blow with a hammer.) As the pressure forcing function has too slow a rise time to excite the natural damped frequency of the gage, it is felt that this oscillation is the result of a shock-induced acceleration.

In a further effort to produce this high frequency ring which appeared superimposed on what was normally felt to be a smooth pressure function, the gage was subjected to sand blasting from a commercial type sand blaster. No apparent change in the output of the gage was observed.

Although it was impossible to produce pressure-time records in the laboratory with superimposed acceleration pulses of many cycle durations, it is believed that the majority of sustained oscillations on the pressure-time records of UPSHOT-KNOTHOLE are acceleration induced. In all records, the frequency of the oscillation superimposed on the pressure records is equal to one of the cantilever mode frequencies or the torsional ring frequency of the gages.

**UNCLASSIFIED**

~~OFFICIAL USE ONLY~~

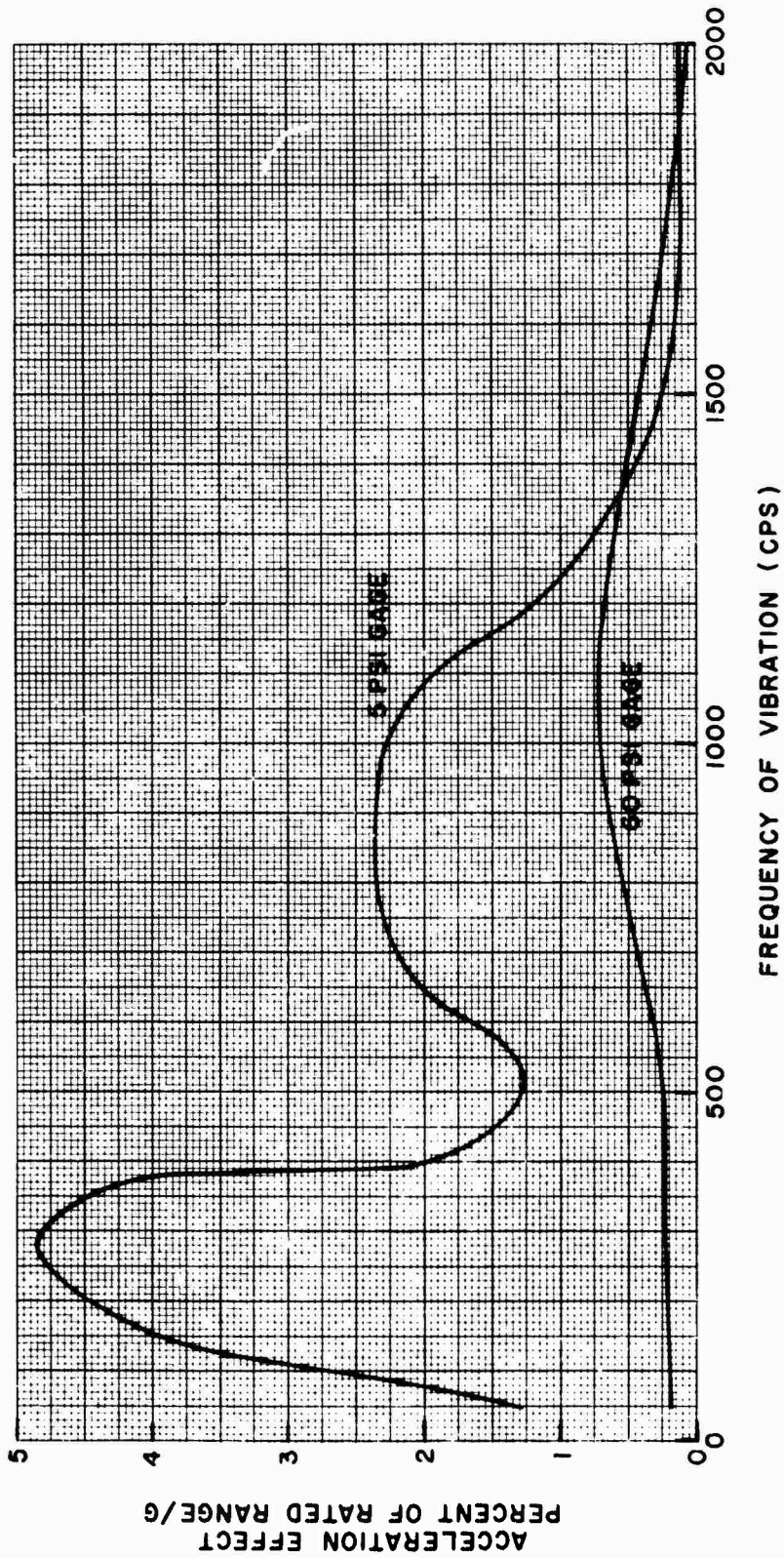

Fig. 6.8 Acceleration Effect vs Frequency of Vibration  
- Wiancko Gage

**UNCLASSIFIED**

~~RESTRICTED USE ONLY~~

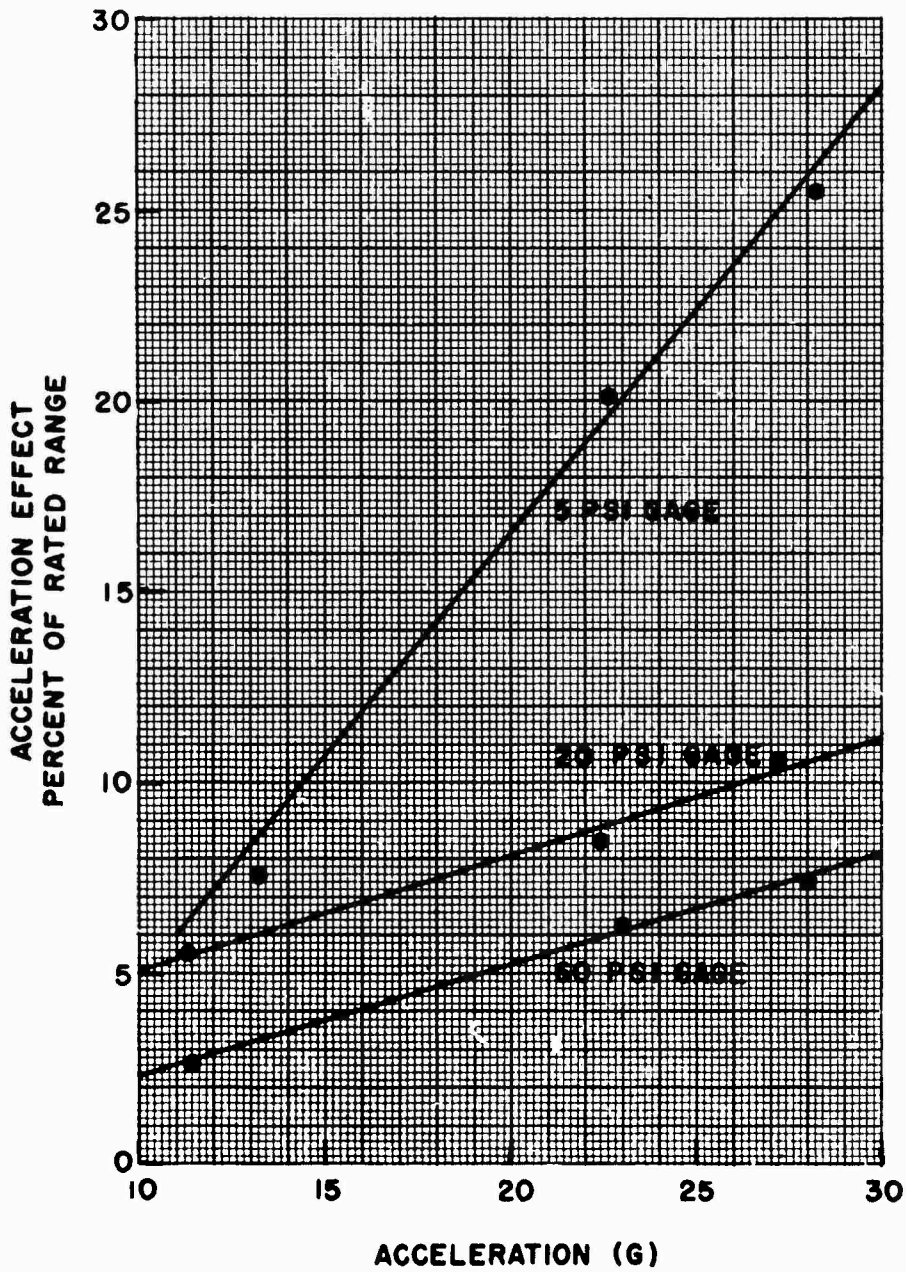

Fig. 6.9 Acceleration Effect vs Acceleration Due to Drop Impact

**UNCLASSIFIED**

~~OFFICIAL USE ONLY~~

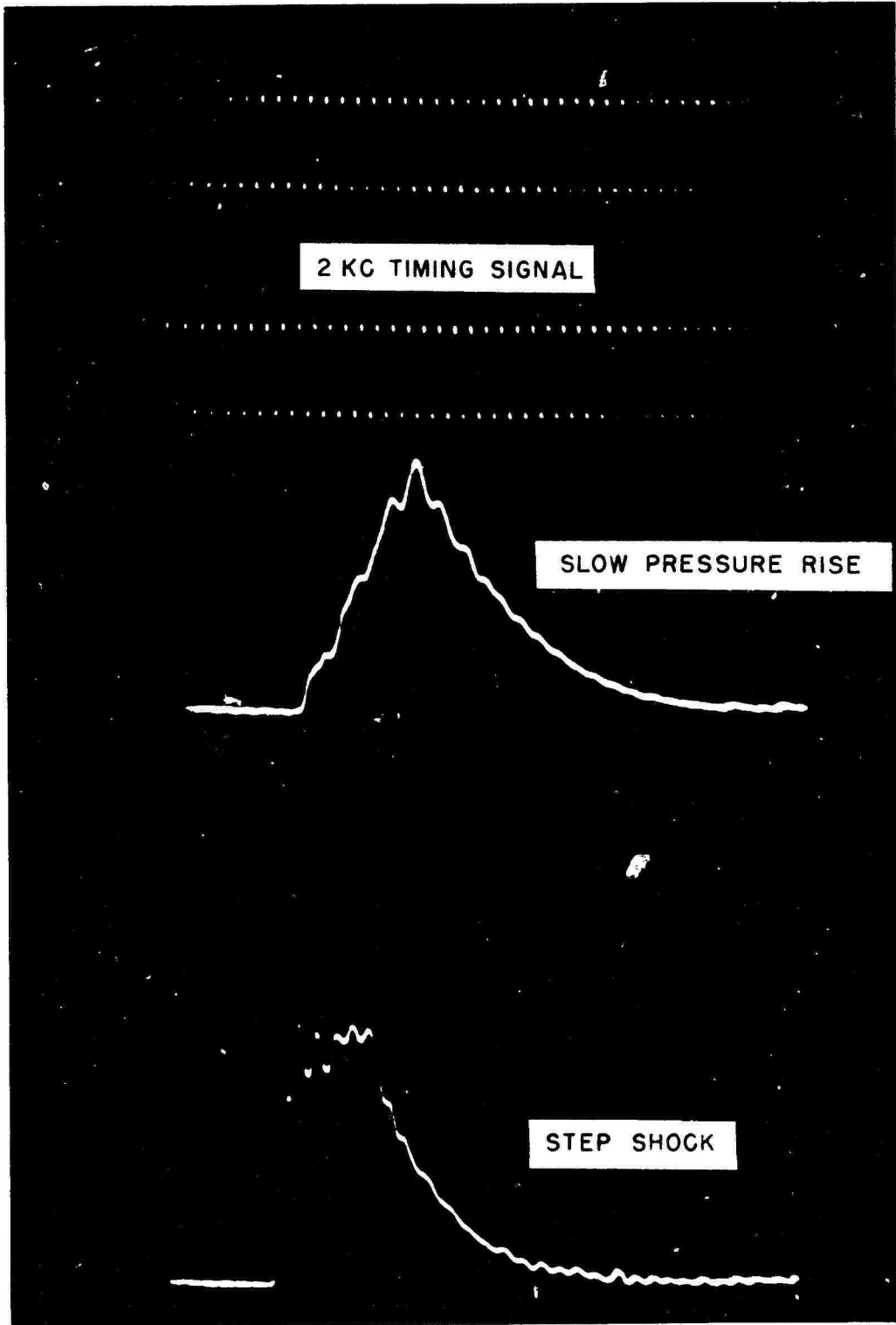

Fig. 6.10 Dynamic Response of Wiancko Gage to Transient Pulses in Shock Tube

**UNCLASSIFIED**  
~~OFFICIAL USE ONLY~~

#### 6.4.4 Temperature Dependence

The gages were equipped with an adjustable "bleed plug" to equalize the pressure in the instrument case as the ambient temperature conditions changed. Changes in temperature produced an 0.02 per cent/ $^{\circ}$ F change in the center frequency of the oscillator; however, the sensitivity change with temperature was so small that this shift can be neglected in determining measured pressures.

In the field it was found that the center frequency of the oscillator shifted at zero time on gages where the thermal radiation could enter the twisted tube. From experimentation with the sun's rays focused through a magnifying glass in the laboratory, it was found that by letting the radiation strike one side of the twisted tube a sizable frequency shift could be produced. By letting the radiation hit the opposite side of the tube, a frequency shift in the other direction was produced. No change was produced when the incident radiation was normal to the gage. In some cases in the field the oscillator had returned to its zero position frequency before the arrival of the shock wave. In cases where it did not, a correction had to be made to the peak pressure measurements, as the gage was not operating over the calibration section of the Inductance-Frequency curve.

#### 6.5 CALIBRATION TECHNIQUE

The gage, with its coil connected as part of the tuning circuit of the Hartley oscillator, was statically calibrated by applying a known pressure to the gage and observing the change in frequency of the oscillator. When the majority of the gages used were calibrated to a pressure of 60 per cent above nominal ratings, a non-linearity of less than 10 per cent was observed. For nominal range or less, the non-linearity became less than 5 per cent. As the gages were to be used to measure negative pressures as well, they were calibrated in the negative direction by the use of a vacuum pump. Fig. 6.11 is a typical calibration curve with the frequency output of the oscillator plotted against pressure.

A slight amount of hysteresis was observed if the gage was not cycled in the negative direction. By subjecting the gage to a number of successive positive excursions, this failure to return to zero seemed to approach a minimum value and became reproducible. However, if the gage were cycled through a negative phase, the calibration was reproducible within 1 per cent. This method was used in the field.

Dynamic response of the gage to a step function is shown in Fig. 6.7. It was found that the dynamic pressure produced the same frequency deviation as an applied static pressure. A dynamic photo was used with each calibration curve to help interpret the pressure-time record.

#### 6.6 ACCURACY

Since the rise time of a damped gage is between 0.4 and 0.6 msec positive pressure spikes of less than a millisecond in duration, such as might occur when the gage is used to measure reflected shock from

**UNCLASSIFIED**

~~CONFIDENTIAL USE ONLY~~

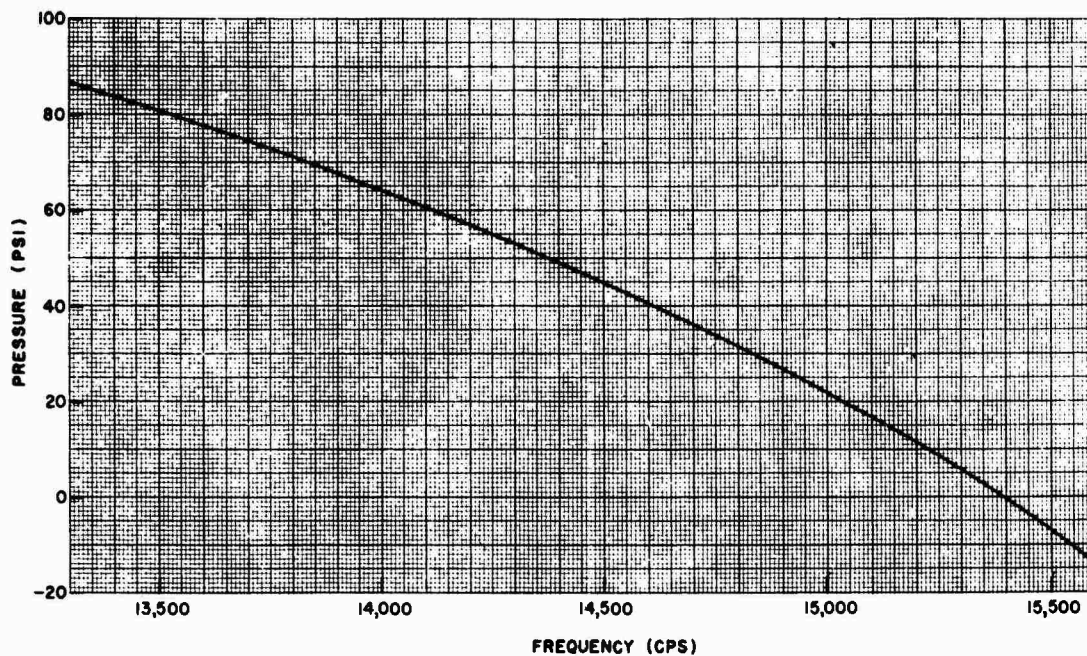

Fig. 6.11 Typical Calibration Curve - Wiancko Gage

small walls or posts, cannot be read to a greater accuracy than 20 per cent. Step functions which have an exponential decay can be read to 2 per cent accuracy; however, because of the hysteresis in the decaying phase, accuracies in this portion are about 5 per cent.

#### 6.7 FIELD PERFORMANCE

The use of this gage on UPSHOT-KNOTHOLE gave excellent results. The signal-to-noise ratios were large and the signal deviations were greater than 8 per cent except where pressures of 5 psi or less were measured. Reproductions of actual pressure-time records are shown in Fig. 2.3. On some records a high frequency oscillation was superimposed on the pressure signals. Since this frequency was close to the ring frequency and/or the cantilever vibrational frequency of the gage, it was felt that this induced oscillation was the result of shock-induced acceleration effects.

A second and more disturbing behavior of some gages was that 14 oscillators failed to operate after zero time, having oscillated normally up to that point. Upon inspection of the gages it was found that the Q of the coils had changed considerably. Fig. 6.12 shows a plot of Q vs frequency for these gages. By replacing the coil of the gage and using the same E-core, the gage and oscillator functioned properly. As the DC characteristics of coils had not noticeably changed, it was assumed that a few turns of the coil had become shorted. The mechanism required to short a small number of turns is not known at present. However, as this effect happened to random gages on the surface as well as those located underground and at distances up to 5000 ft from ground zero, it is felt that this effect must be due to an electro-

**UNCLASSIFIED**

~~OFFICIAL USE ONLY~~

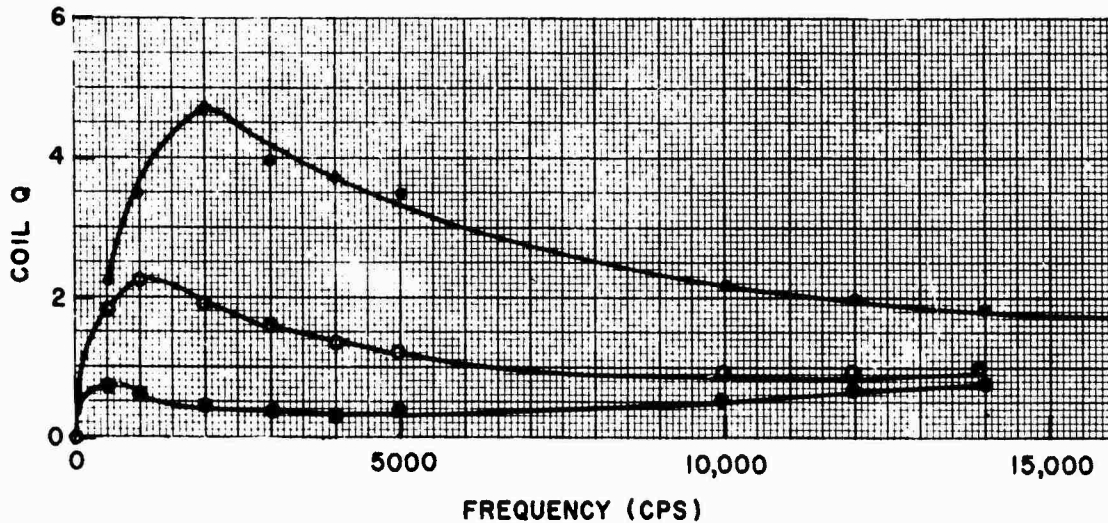

Fig. 6.12 Q of Coil vs Frequency of Oscillator for Wiancko Gages Failing in Field

magnetic-induced current in the coil.

#### 6.8 CONCLUSIONS AND RECOMMENDATIONS

For its present application, the Wiancko gage gave better records than had been previously obtained with the Bendix gage. However, in the event of further research and modification of this gage, there are several directions for improvement that should be investigated as follows:

- a. Limit the motion of the armature to purely torsional rotation.
- b. Explore the possibilities of new core material to obtain higher Q's.
- c. Reduce the mass of the armature to lower the acceleration sensitivity.
- d. Design a magnetic circuit such that the inductance of the E-coil varies inversely as the square of the gap spacing over the region of operation, thus giving linear transfer characteristics.

**UNCLASSIFIED**

~~OFFICIAL USE ONLY~~

## BIBLIOGRAPHY

1. Morris et al, Project 1.1a and 1.2, Operation UPSHOT-KNOTHOLE, Pressure Measurements in the Air and on the Ground, AFSWP, WT-710 (Secret Restricted Data)
2. Aronson et al, Project 1.3 and 1.5, Operation TUMBLER, Free-Air and Ground-Level Pressure Measurements, AFSWP, WT-513 (Secret Restricted Data).
3. Petes, Frequency Modulated Magnetic Tape Recording and Playback Instrumentation System, NAVORD 2713, 24 Feb 1953 (Unclassified).
4. Price, Sokol and Anastasion, Measurement with Variable Inductance Diaphragm Gage Sec. 1 of AFSWP, WT-53 (Secret Restricted Data).
5. Price and Anastasion, Approximate High-Frequency Response Requirement for Air Blast Pressure-Time Measuring Systems, NAVORD 1747. 3 Jan 1951 (Unclassified).
6. J. D. Shreve, Jr., Project 1.10, Operation TUMBLER, Appendix B of Pressure-Distance-Height Study of 250 lb. Spheres, AFSWP, WT-520 (Secret Restricted Data).
7. Vader and Walthall, Annex 1.6, Part IV, Section 2 of Scientific Director's Report, Operation GREENHOUSE, AFSWP, WT-53 (Secret Restricted Data).
8. Morris and Petes, Project 3.28.2, Pressure Measurements for Various Projects of Program Three, AFSWP, WT-739 (Secret Restricted Data).

**UNCLASSIFIED**

~~OFFICIAL USE ONLY~~

## DISTRIBUTION

### Military Distribution Categories 5 -21

	<b>ARMY ACTIVITIES</b>		
1	Asst. Chief of Staff, G-3, D/A, Washington 25, D.C ATTN: Dep. CoFS, G-3 (RR&SW)	49	Commanding Officer, Transportation R&D Station, Ft. Eustis, Va.
2	Deputy Chief of Staff for Logistics, D/A, Washington 25, D.C. ATTN: Director of Research & Development	50	Director, Technical Documents Center, Evans Signal Laboratory, Belmar, N.J.
3	Chief of Ordnance, D/A, Washington 25, D.C. ATTN: ORDTX-AR	51	Director, Waterways Experiment Station, PO Box 631, Vicksburg, Miss. ATTN: Library
4- 6	Chief Signal Officer, D/A, P&O Division, Washington 25, D.C. ATTN: SIGOP	52	Director, Armed Forces Institute of Pathology, 7th and Independence Avenue, S.W., Washington 25, D.C.
7	The Surgeon General, D/A, Washington 25, D.C. ATTN: Chief, R&D Division	53	Director, Operations Research Office, Johns Hopkins University, 7100 Connecticut Ave., Chevy Chase, Md. ATTN: Library
8- 9	Chief Chemical Officer, D/A, Washington 25, D.C.	54- 50	Technical Information Service, Osk Ridge, Tenn. (Surplus)
10	The Quartermaster General, CBR, Liaison Officer, Research and Development Div., D/A, Washington 25, D.C.		
11- 15	Chief of Engineers, D/A, Washington 25, D.C. ATTN: KNGNB		
16	Chief of Transportation, Military Planning and Intelligence Div., Washington 25, D.C.		
17- 19	Commanding General, Continental Army Command, Ft. Monroe, Va.		<b>NAVY ACTIVITIES</b>
20	President, Board #1, Headquarters, Continental Army Command, Ft. Bregg, N.C.	61- 62	Chief of Naval Operations, D/N, Washington 25, D.C. ATTN: OP-36
21	President, Board #2, Headquarters, Continental Army Command, Ft. Knox, Ky.	63	Chief of Naval Operations, D/N, Washington 25, D.C. ATTN: OP-03EG
22	President, Board #3, Headquarters, Continental Army Command, Ft. Benning, Ga.	64	Director of Naval Intelligence, D/N, Washington 25, D.C. ATTN: OP-92ZV
23	President, Board #4, Headquarters, Continental Army Command, Ft. Bliss, Tex.	65	Chief, Bureau of Medicine and Surgery, D/N, Washington 25, D.C. ATTN: Special Weapons Defense Div.
24	Commanding General, U.S. Army Caribbean, Ft. Amador, C.Z. ATTN: Cml. Off.	66	Chief, Bureau of Ordnance, D/N, Washington 25, D.C.
25- 26	Commander-in-Chief, Far East Command, APO 500, c/o FM, San Francisco, Calif. ATTN: ACofS, J-3	67	Chief, Bureau of Ships, D/N, Washington 25, D.C. ATTN: Code 348
27- 28	Commanding General, U.S. Army Europe, APO 403, c/o FM, New York, N.Y. ATTN: OPOT Div., Combat Dev. Br.	68	Chief, Bureau of Yards and Docks, D/N, Washington 25, D.C. ATTN: D-440
29- 30	Commandant, Command and General Staff College, Ft. Leavenworth, Kan. ATTN: ALLS(AS)	69	Chief, Bureau of Supplies and Accounts, D/N, Washington 25, D.C.
31	Commandant, The Artillery School, Ft. Sill, Okla.	70- 71	Chief, Bureau of Aeronautics, D/N, Washington 25, D.C.
32	Secretary, The A&M Branch, The Artillery School, Ft. Bliss, Tex. ATTN: Lt. Col. Albert D. Epley, Dept. of Tactics and Combined Arms	72	Chief of Naval Research, Department of the Navy Washington 25, D.C. ATTN: LT(jg) F. McKee, USN
33	Commanding General, Medical Field Service School, Brooke Army Medical Center, Ft. Sam Houston, Tex.	73	Commander-in-Chief, U.S. Pacific Fleet, Fleet Post Office, San Francisco, Calif.
34	Director, Special Weapons Development Office, Ft. Bliss, Tex. ATTN: Lt. Arthur Jeskierny	74	Commander-in-Chief, U.S. Atlantic Fleet, U.S. Naval Base, Norfolk 11, Va.
35	Commandant, Army Medical Service Graduate School, Welter Reed Army Medical Center, Washington 25, D.C.	75- 78	Commandant, U.S. Marine Corps, Washington 25, D.C. ATTN: Code AO3H
36	Superintendent, U.S. Military Academy, West Point, N.Y. ATTN: Prof. of Ordnance	79	President, U.S. Naval War College, Newport, R.I.
37	Commandant, Chemical Corps School, Chemical Corps Training Command, Ft. McClellan, Ala.	80	Superintendent, U.S. Naval Postgraduate School, Monterey, Calif.
38	Commanding General, Research and Engineering Command, Army Chemical Center, Md. ATTN: Deputy for RW and Non-Toxic Material	81	Commanding Officer, U.S. Naval Schools Command, U.S. Naval Station, Treasure Island, San Francisco, Calif.
39- 40	Commanding General, Aberdeen Proving Grounds, Md. (inner envelope) ATTN: RD Control Officer (for Director, Ballistics Research Laboratory)	82	Commanding Officer, U.S. Fleet Training Center, Naval Base, Norfolk 11, Va. ATTN: Special Weapons School
41- 43	Commanding General, The Engineer Center, Ft. Belvoir, Va. ATTN: Asst. Commandant, Engineer School	83- 84	Commanding Officer, U.S. Fleet Training Center, Naval Station, San Diego 36, Calif. ATTN: (SPWP School)
44	Commanding Officer, Engineer Research and Development Laboratory, Ft. Belvoir, Va. ATTN: Chief, Technical Intelligence Branch	85	Commanding Officer, Air Development Squadron 5, VX-5, U.S. Naval Air Station, Moffett Field, Calif.
45	Commanding Officer, Picatinny Arsenal, Dover, N.J. ATTN: ORDBB-TK	86	Commanding Officer, U.S. Naval Damage Control Training Center, Naval Base, Philadelphia 12, Pa. ATTN: ABC Defense Course
46	Commanding Officer, Army Medical Research Laboratory, Ft. Knox, Ky.	87	Commanding Officer, U.S. Naval Unit, Chemical Corps School, Army Chemical Training Center, Ft. McClellan, Ala.
47- 48	Commanding Officer, Chemical Corps Chemical and Radiological Laboratory, Army Chemical Center, Md. ATTN: Tech. Library	88	Commander, U.S. Naval Ordnance Laboratory, Silver Spring 19, Md. ATTN: EE
		89	Commander, U.S. Naval Ordnance Laboratory, Silver Spring 19, Md. ATTN: EH
		90	Commander, U.S. Naval Ordnance Laboratory, Silver Spring 19, Md. ATTN: R

**UNCLASSIFIED**  
~~OFFICIAL USE ONLY~~

UNCLASSIFIED

OFFICIAL USE ONLY

- 91 Commander, U.S. Naval Ordnance Test Station, Azusa, Calif. 138
- 92 Officer-in-Charge, U.S. Naval Civil Engineering Research and Evaluation Lab., U.S. Naval Construction Battalion Center, Port Hueneeme, Calif. ATTN: Code 753 139
- 93 Commanding Officer, U.S. Naval Medical Research Inst., National Naval Medical Center, Bethesda 14, Md. 140-141
- 94 Director, U.S. Naval Research Laboratory, Washington 25, D.C. ATTN: Code 2029 142-147
- 95 Commanding Officer and Director, U.S. Navy Electronics Laboratory, San Diego 52, Calif. ATTN: Code 4223 148-149
- 96-97 Commanding Officer, U.S. Naval Radiological Defense Laboratory, San Francisco 24, Calif. ATTN: Technical Information Division 150-152
- 98 Director, Naval Air Experimental Station, Air Materiel Center, U. S. Naval Base, Philadelphia, Penn. 153
- 99-100 Commanding Officer and Director, David W. Taylor Model Basin, Washington 7, D.C. ATTN: Library 154
- 101 Commander, U.S. Naval Air Development Center, Johnsville, Pa. 155
- 102 Director, Office of Naval Research Branch Office, 1000 Geary St., San Francisco, Calif. 156-157
- 103-109 Technical Information Service, Oak Ridge, Tenn. (Surplus) 158-164

AIR FORCE ACTIVITIES

- 110 Asst. for Atomic Energy, Headquarters, USAF, Washington 25, D.C. ATTN: DCS/O 165
- 111 Director of Operations, Headquarters, USAF, Washington 25, D.C. ATTN: Operations Analysis 166
- 112 Director of Plans, Headquarters, USAF, Washington 25, D.C. ATTN: War Plans Div. 167
- 113 Director of Research and Development, Headquarters, USAF, Washington 25, D.C. ATTN: Combat Components Div. 168
- 114-115 Director of Intelligence, Headquarters, USAF, Washington 25, D.C. ATTN: APOIN-IB2 169
- 116 The Surgeon General, Headquarters, USAF, Washington 25, D.C. ATTN: Rio. Def. Br., Pre. Med. Div. 170-175
- 117 Deputy Chief of Staff, Intelligence, Headquarters, U.S. Air Forces Europe, APO 633, c/o FM, New York, N.Y. ATTN: Directorate of Air Targets 176-177
- 118 Commander, 497th Reconnaissance Technical Squadron (Augmented), APO 623, c/o FM, New York, N.Y. 178-186
- 119 Commander, Far East Air Forces, APO 925, c/o FM, San Francisco, Calif. 187
- 120 Commander, Strategic Air Command, Offutt Air Force Base, Omaha, Nebraska. ATTN: Special Weapons Branch, Inspection Div., Inspector General 188-194
- 121 Commander, Tactical Air Command, Langley AFB, Va. ATTN: Documents Security Branch 195-197
- 122 Commander, Air Defense Command, Ent AFB, Colo. 198-200
- 123-124 Commander, Wright Air Development Center, Wright-Patterson AFB, Dayton, O. ATTN: WCRRN, Blast Effects Research 201-204
- 125 Commander, Air Training Command, Scott AFB, Belleville, Ill. ATTN: DCS/O GTP 205-206
- 126 Commander, Air Research and Development Command, PO Box 1395, Baltimore, Md. ATTN: RDDW 207
- 127 Commander, Air Proving Ground Command, Eglin AFB, Fla. ATTN: AG/TRB 208-220
- 128-129 Director, Air University Library, Maxwell AFB, Ala.
- 130-137 Commander, Flying Training Air Force, Waco, Tex. ATTN: Director of Observer Training

- Commander, Crew Training Air Force, Randolph Field, Tex. ATTN: 202S, DCS/O
- Commander, Headquarters, Technical Training Air Force, Gulfport, Miss. ATTN: TA&D
- Commandant, Air Force School of Aviation Medicine, Randolph AFB, Tex.
- Commander, Wright Air Development Center, Wright-Patterson AFB, Dayton, O. ATTN: WCOSI
- Commander, Air Force Cambridge Research Center, 230 Albany Street, Cambridge 39, Mass. ATTN: CRQST-2
- Commander, Air Force Special Weapons Center, Kirtland AFB, N. Mex. ATTN: Library
- Commandant, USAF Institute of Technology, Wright-Patterson AFB, Dayton, O. ATTN: Resident College
- Commander, Lowry AFB, Denver, Colo. ATTN: Department of Armament Training
- Commander, 1009th Special Weapons Squadron, Headquarters, USAF, Washington 25, D.C.
- The RAND Corporation, 1700 Main Street, Santa Monica, Calif. ATTN: Nuclear Energy Division Technical Information Service, Oak Ridge, Tenn. (Surplus)

OTHER DEPARTMENT OF DEFENSE ACTIVITIES

- 165 Asst. Secretary of Defense, Research and Development, D/T, Washington 25, D.C.
- 166 U.S. National Military Representative, Headquarters, SHAPE, APO 55, c/o FM, New York, N.Y. ATTN: Col. J. P. Healy
- 167 Director, Weapons Systems Evaluation Group, OSD, Rm 2E1006, Pentagon, Washington 25, D.C.
- 168 Armed Services Explosives Safety Board, D/D, Building T-7, Gravelly Point, Washington 25, D.C.
- 169 Commandant, Armed Forces Staff College, Norfolk 11, Va. ATTN: Secretary
- 170-175 Commanding General, Field Command, Armed Forces Special Weapons Project, PO Box 5100, Albuquerque, N. Mex.
- 176-177 Commanding General, Field Command, Armed Forces, Special Weapons Project, PO Box 5100, Albuquerque, N. Mex. ATTN: Technical Training Group
- 178-186 Chief, Armed Forces Special Weapons Project, Washington 25, D.C.
- 187 Office of the Technical Director, Directorate of Effects Tests, Field Command, AFSWP, PO Box 577, Menlo Park, Calif. ATTN: Dr. E. B. Doll
- 188-194 Technical Information Service, Oak Ridge, Tenn. (Surplus)

ATOMIC ENERGY COMMISSION ACTIVITIES

- 195-197 U.S. Atomic Energy Commission, Classified Technical Library, 1901 Constitution Ave., Washington 25, D.C. ATTN: Mrs. J. M. O'Leary (For DMA)
- 198-200 Los Alamos Scientific Laboratory, Report Library, PO Box 1663, Los Alamos, N. Mex. ATTN: Helen Redman
- 201-204 Sandia Corporation, Classified Document Division, Sandia Base, Albuquerque, N. Mex. ATTN: Martin Lucero
- 205-206 University of California Radiation Laboratory, PO Box 808, Livermore, Calif. ATTN: Margaret Edlund
- 207 Weapon Data Section, Technical Information Service, Oak Ridge, Tenn.
- 208-220 Technical Information Service, Oak Ridge, Tenn. (Surplus)

OFFICIAL USE ONLY

UNCLASSIFIED

AK-148 (Rev. 7-59)