

UNCLASSIFIED

AD NUMBER

ADB001109

LIMITATION CHANGES

TO:

Approved for public release; distribution is unlimited.

FROM:

Distribution authorized to U.S. Gov't. agencies only; Test and Evaluation; MAR 1974. Other requests shall be referred to Air Force Avionics Lab., Wright-Patterson AFB, OH 45433.

AUTHORITY

AFAL ltr 17 Sep 1979

THIS PAGE IS UNCLASSIFIED

THIS REPORT HAS BEEN DELIMITED
AND CLEARED FOR PUBLIC RELEASE
UNDER DOD DIRECTIVE 5200.20 AND
NO RESTRICTIONS ARE IMPOSED UPON
ITS USE AND DISCLOSURE.

DISTRIBUTION STATEMENT A

APPROVED FOR PUBLIC RELEASE;
DISTRIBUTION UNLIMITED.

AFAL-TR-74-66

L

AD B 001 109

INTERAND TARGET ANNOTATION SYSTEM

INTERAND CORPORATION
450 EAST OHIO STREET
CHICAGO, ILLINOIS 60611

TECHNICAL REPORT AFAL-TR-74-66

FINAL REPORT FOR PERIOD 16 APRIL 1973 - 17 AUGUST 1973

NOVEMBER 1974

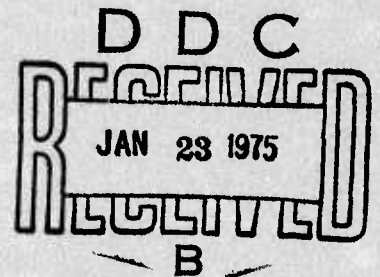

Distribution limited to U.S. Government agencies only because test and evaluation data is included. March 1974. Other requests for this document must be referred to AFAL/TSR Stinfo.

AIR FORCE AVIONICS LABORATORY
AIR FORCE SYSTEMS COMMAND
WRIGHT-PATTERSON AIR FORCE BASE, OHIO 45433

NOTICE

When Government drawings, specifications, or other data are used for any purpose other than in connection with a definitely related Government procurement operation, the United States Government thereby incurs no responsibility nor any obligation whatsoever; and the fact that the government may have formulated, furnished, or in any way supplied the said drawings, specifications, or other data, is not to be regarded by implication or otherwise as in any manner licensing the holder or any other person or corporation, or conveying any rights or permission to manufacture, use or sell any patented invention that may in any way be related thereto.

Copies of this report should not be returned unless return is required by security consideration, contractual obligations, or notice on a specific document.

This technical report has been reviewed and is approved for publication.

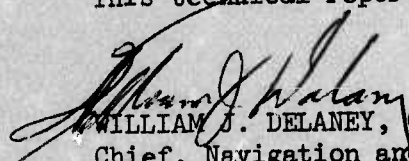
WILLIAM J. DELANEY, Colonel, USAF
Chief, Navigation and
Weapon Delivery Division

UNCLASSIFIED

SECURITY CLASSIFICATION OF THIS PAGE (When Date Entered)

REPORT DOCUMENTATION PAGE		READ INSTRUCTIONS BEFORE COMPLETING FORM
1. REPORT NUMBER AFAL-TR-74-66	2. GOVT ACCESSION NO.	3. RECIPIENT'S CATALOG NUMBER
4. TITLE (and Subtitle) Target Information Annotation Method		5. TYPE OF REPORT & PERIOD COVERED Final - 16 April 1973
		6. PERFORMING ORG. REPORT NUMBER GS-7301
7. AUTHOR(s) James Baker Carl Groom		8. CONTRACT OR GRANT NUMBER(s) F33615-73-C-1249
		10. PROGRAM ELEMENT, PROJECT, TASK AREA & WORK UNIT NUMBERS 76220115
9. PERFORMING ORGANIZATION NAME AND ADDRESS Interand Corporation 450 East Ohio Street Chicago, Ill. 60611		12. REPORT DATE November 1974
11. CONTROLLING OFFICE NAME AND ADDRESS AFAL/NVT-3 Wright-Patterson AFB, Ohio 45433		13. NUMBER OF PAGES 93
		15. SECURITY CLASS. (of this report) Unclassified
14. MONITORING AGENCY NAME & ADDRESS (if different from Controlling Office)		15a. DECLASSIFICATION/DOWNGRADING SCHEDULE
16. DISTRIBUTION STATEMENT (of this Report) Distribution limited to U.S. Government agencies only because test and evaluation data is included. March 1974. Other requests for this document must be referred to AFAL/TSR Stinfo.		
17. DISTRIBUTION STATEMENT (of the abstract entered in Block 20, if different from Report)		
18. SUPPLEMENTARY NOTES		
19. KEY WORDS (Continue on reverse side if necessary and identify by block number) Video Annotation, Target Annotation, Graphics Distribution		
20. ABSTRACT (Continue on reverse side if necessary and identify by block number) System provides facilities to record notes, transfer visual information to sensor operators, record graphic annotation in synchronism with the sensor video recording. Functional descriptions are given of subassemblies including the position decoder, graphics distribution unit, recorder/reproducer, scan converter and video keyer.		

DD FORM 1 JAN 73 1473

EDITION OF 1 NOV 65 IS OBSOLETE

UNCLASSIFIED

SECURITY CLASSIFICATION OF THIS PAGE (When Date Entered)

UNCLASSIFIED

SECURITY CLASSIFICATION OF THIS PAGE(When Data Entered)

Target annotation system
Audio recorder/reproducer
Graphics transceiver
Position decoder
Converter control
Scan converter
Stainless steel overlay
Gunship video system
Processing amplifier
Distribution amplifier
Graphics distribution unit
Cartridge tape deck
Target Annotation Signal Processor (TASP)
Video processing system
Graphical processing system
Audio taping system

UNCLASSIFIED

SECURITY CLASSIFICATION OF THIS PAGE(When Data Entered)

FOREWORD

This report describes a target annotation system which allows an operator to make handwritten notes in electronic form appear directly upon television imagery such as might be obtained in aerial reconnaissance or other military operations using TV sensors. The graphical annotations can be recorded either in direct format on a suitable video tape recorder or may be stored on the audio track of a video tape recorder and displayed optionally upon replay of the basic imagery.

TABLE OF CONTENTS

INTRODUCTION	1
SYSTEM FUNCTIONAL DESCRIPTION	2
COMPONENT FUNCTIONAL DESCRIPTION	4
504 Position Decoder	4
FCO Push Button Control	4
TV and IR Control Units	6
Graphics Distribution Unit	7
Recorder/Reproducer	7
Converter Control	8
Scan Converter	9
Video Keyer	9
Genlock	10
Processing Amplifier	11
Distribution Amplifier	11
Tape Deck	12
Cables	14
OPERATIONAL INSTRUCTIONS	15
Pre-Flight Set Up	16
Operational Instructions	17
Adjustments	18
CIRCUIT DESCRIPTION, 504 POSITION DECODER	20
Power Supply	20
Slate Driver	21
Position Decoding Circuits	22
CARD DESCRIPTIONS, RECORDER/REPRODUCER	27
Graphics Input Card	27
Voltage Controlled Oscillator (VCO) Card	27
Transmit Logic Card	29
Transmit Output Card	29
Power Supply Card	30
Audio Input Card	31
Filter Card	31
Phase Locked Loop (PLL) Card	32
PLL Buffer Card	33
PLL Logic Card	34
Lock Logic Card	35
Error Compensation Card	37
Record Logic Card	38
TROUBLESHOOTING GUIDE	40
APPENDIX A -- DRAWINGS, SCHEMATICS, AND DIAGRAMS	54

LIST OF ILLUSTRATIONS

FIGURE		PAGE
1	Functional Diagram, TASP System	55
2	TASP Electronic Packages	56
3	FCO Control Panel	57
4	Schematic Push Button Logic	58
5	Graphics Playback Switch F.C.O. Push Button Control	59
6	Wiring Diagram, Sensor Control Unit	60
7	Distribution Unit	61
8	Wiring Diagram, Graphics Dist'n Unit	62
9	Converter Control Schematic	63
10	Video Keyer Schematic	64
11	TASP System Cabling Diagram	65
12	Wiring Diagram for 6 Conductor Cable	66
13	Wiring Diagram for 10 Conductor Cable	67
14	Wiring Diagram for 35 Conductor Cable	68
15	Wiring Diagram for 37 Conductor Cable	69
16	Schematic Diagram TASP, Position Decoder Model 504	70
17	Graphics Input Schematic TASP	71
18	VCO Schematic TASP	72
19	Transmit Logic (Type 1) TASP	73
20	Transmit Output Schematic TASP	74
21	Power Supply Schematic TASP	75
22	Audio Input Schematic TASP	76
23	Filter Schematic TASP	77
24	PLL Schematic TASP	78
25	PLL Buffer Schematic TASP	79
26	PLL Logic Schematic TASP	80
27	Lock-Logic Schematic TASP	81
28	Error Compensation Schematic	82

FIGURE		PAGE
29	Record Logic Schematic TASP	83
30	Primary Power Wiring, TASP	84
31	Connectors J2 & J4	85

INTRODUCTION

The INTERAND Target Annotation System operates in conjunction with the video distribution and recording system in the AC-130 aircraft. Its primary purpose is to increase the effectiveness of aircraft personnel during flight. This is accomplished by providing the Fire Control Officer (FCO) with a means of making written notations without ever diverting his attention from the video scene that he is monitoring.

Notations he makes are electronically "written" into the video display and the composite video is available for viewing on any monitor in the aircraft. Thus, a means of instantaneous written communication, with or without reference to the background video, is provided to crew members.

At the FCO's option, the composite video may be recorded on video tape for later playback. Where this is impractical or undesirable, the FCO may choose to record only his notations, divorced from the video displayed when they were written, using the audio recorder/reproducer furnished with the system.

This final report describes the functions of each of the major components of the system and indicates the interrelationship of these components. It provides a set of operating instructions so that the operation of the system may be better visualized. Detailed, in-depth descriptions of each circuit are included to document the technology incorporated within the system. A set of troubleshooting procedures summarizes the steps that allow quick diagnosis of a wide variety of symptoms. Finally, a complete set of system drawings is included in Appendix A.

SYSTEM FUNCTIONAL DESCRIPTION

This section provides a brief functional description of the INTERAND Target Annotation System. A functional diagram of the entire package is given on drawing SK-GS-09, Figure A-1. This drawing indicates signal and information flow only, and is not to be confused with cabling or wiring diagrams.

The electronic packages associated with the system are installed in five locations, indicated upon drawing SK-GS-01, Figure A-2. At the Fire Control Officer's (FCO) console, there is installed one Push Button Control and one Model 504 Position Decoder. The latter provides drive signals to extract positional data from a perforated stainless steel mesh installed over the FCO viewing monitor. The former remotely controls the Position Decoder, a portion of the Graphics Distribution Unit (GDU) and several functions of the Target Annotation Signal Processor (TASP) package.

At both the TV and IR Sensor Operator positions, there are installed identical control units which control incoming video to the corresponding monitors. These remotely control corresponding portions of the GDU.

Installed immediately adjacent to the on-board Video Switching Unit (VSU) is the GDU, which routes all video information associated with the Target Annotation System. This unit is remotely controlled by the FCO Push Button Control and TV and IR Sensor control units.

The largest package of the INTERAND Target Annotation System is the TASP package, installed to the rear of the unused Radar Operator position. This consists of three subsystems: a Video Processing system, a Graphical Processing system, and an Audio Taping system.

The Video Processing system consists of an 875 line Genlock,

a Processing Amplifier, a Distribution Amplifier, and a Video Keyer. The Graphical Processing system consists of a Recorder/Reproducer, a Converter Control, and a Scan Converter. The Audio Taping system consists of a broadcast-quality cartridge tape deck and a 28V d.c. /110V a.c. 60 Hz inverter of superior frequency stability.

In operation, a video source (NTV, WTV, IR) is selected at the VSU by the FCO. This video signal is routed through the GDU to the TASP package. In the TASP package, it passes through the Video Keyer, Processing Amplifier, and Distribution Amplifier before appearing upon the FCO TV monitor. A position-sensitive overlay, driven by the Position Decoder, is placed over the FCO monitor. When the FCO marks upon the overlay with his pen, his markings are detected by the Position Decoder, written out by the Scan Converter, and keyed into the FCO video display by the Video Keyer. If either the TV or IR operator activates his remote controls, he may view the same display upon his own monitor.

If the tape deck is turned on, a record of the markings is simultaneously made upon the audio track of the deck. This record may be easily played back at any time. In addition, graphical data from another location may be received, or locally generated graphics may be transmitted through an RF link by simple interconnections.

Graphical data is continuously recorded upon one audio channel of the on-board VTR. Also, the FCO may choose to record the graphical information in the video data on the video track of the VTR. The FCO controls this option, as well as graphics playback, by use of the FCO Push Button Control.

COMPONENT FUNCTIONAL DESCRIPTION

The following sections provide a functional description of all major components of the INTERAND Target Annotation System. An overview of each of the major electronic packages sufficient to provide a conceptual appreciation of the system is given. A more comprehensive break-down and understanding of each component may be obtained by examining the more detailed circuit descriptions and/or troubleshooting guides that follow the functional descriptions.

Devices utilized directly by the operators will be described first, then the GDU, and finally the TASP package components.

504 Position Decoder

The 504 Position Decoder is mounted on the rear portion of the high resolution 14" monitor used by the FCO. Through cables, it provides power for the Graphics Control Panels at both the FCO and the Sensor position.

In addition, the 504 Position Decoder provides drive signals to the stainless steel mesh overlay mounted directly over the monitor. These signals establish a voltage gradient across the mesh alternately in X and Y axes at a rate of 10 kHz. The pen, when pressed against the overlay, is used as a voltage sensor. Electronics provided within the Position Decoder convert the sensed 10 kHz signal into d. c. voltages, corresponding to X and Y positions, and a pen up/down signal.

FCO Push Button Control

These three signals (i. e. , X position, Y position, and pen up/down), together with the options selected at the FCO Push Button Control, are conveyed to the Recorder/Reproducer in the TASP package through a 37 pin cable. The FCO Push Button Control is installed in the FCO console, to the lower right of the monitor.

The FCO Push Button Control contains nine push buttons and two potentiometers. Five of the push buttons—the four white push buttons and the one labeled "ERASE"—are used while writing with the pen upon the monitor to select or modify the graphical signal produced. Depressing the button with the unbroken line engraved upon it will cause an unbroken line to be written by the pen. Pressing a button labeled with a dotted or dashed line will produce a corresponding type of line when writing. The fourth white button is marked with a circle; pushing it will yield a circle or cursor which moves with the pen, but does not write a permanent line. All of these buttons light when depressed and "latch" electronically, so they need not be held down to use the desired line type. See drawing D7212-39, Figure A-3. The "ERASE" push button erases recorded graphics only from the screen. The wiring diagram corresponding to these five controls is shown on drawing SK-GS-14, Figure A-4.

The other four FCO push buttons remotely control functions that are less often used. The "GRAPHICS ON" push button is an alternate action switch which remotely turns on the GDU. If this switch is off, no graphics are generated, and all three positions (i. e., FCO, IR Sensor, and TV Sensor) operate as they would without the TASP system installed. The FCO "GRAPHICS ON" push button enables the entire TASP system.

The "GRAPHICS PLAYBACK" push button must be turned on when it is desired (1) to play back recorded graphics from the cartridge tape deck provided, (2) to playback from the VTR audio track, or (3) to operate through a radio voice-grade channel as a graphics transceiver.

The "TAPE STOP" push button contains an indicating light which warns that the cartridge tape deck has stopped. This occurs when either the cartridge is full or the tape deck has been manually stopped.

Depressing the push button energizes a remote start for the cartridge tape deck. If the tape cartridge is full, this will not effect a restart and the light will continue to burn.

The "VIDEO RECORD GRAPHICS" push button controls the option of recording video signal graphics in the video track of the VTR. If the switch is on, graphics are added to the recorded video. If the switch is off, the VTR records the signal without the graphics, independent of the picture viewed by the FCO. The wiring diagram for these four controls is shown on drawing SK-GS-08, Figure A-5.

The two screwdriver-adjustable potentiometers set the X and Y positions, respectively, for the graphical display. These are used to exactly align the dot drawn with the tip of the pen used by the FCO. These adjustments need rarely be made after initial installation; therefore, these potentiometers have locking nuts to secure them after they have been initially set.

TV and IR Control Units

The TV operator and IR operator controls are identical in appearance and function. Each control consists of a single alternate action push button switch, labeled "GRAPHICS ON." If the switch is on, it is illuminated, and the operator can view the same display that the FCO sees. The FCO display will normally contain graphical annotations and data. If the "GRAPHICS ON" switch is off, the video display viewed at the sensor positions is selected by the on-board Video Switching Unit in the conventional manner. Both "GRAPHICS ON" switches are inoperative unless the GDU has been powered up at the FCO console. The electrical details of these units are shown on drawing SK-GS-11, Figure A-6.

Graphics Distribution Unit

The GDU is located in a 7-1/4 in. x 4-3/4 in. x 2-1/4 in. cast aluminum enclosure, and controls all routing of video signals used in the Target Annotation system. It is remotely controlled by the push button controls located at the FCO, TV operator, and IR operator consoles. The GDU is installed immediately adjacent to the on-board VSU. This permits relatively short runs of triax and easy installation. The GDU is provided with three round MS type connectors, through which it is controlled, and thirteen triax connectors, through which the video signals are passed.

Within the GDU, the video routing is accomplished by means of five Form C reed relays. These provide a fail-safe power-down state. If power is not provided to the GDU, the relays will disconnect the TASP video feeds, and connect the FCO, sensor monitors, and VTR video sources directly back to the corresponding outputs of the VSU. All relay coils are shunted with diodes to eliminate transient spikes. A complete schematic of the GDU is shown on drawing SK-GS-06, Figure A-7.

The FCO remotely controls application of power to the GDU with the "GRAPHICS ON" push button at his console. In addition, the FCO may select to direct normal (non-annotated) or annotated graphics to the Video Tape Recorder on board. The TV and IR operators may also select either normal or annotated video sources at each of their consoles. The FCO remote control is connected through J2; the IR and TV operators connect through J1 and J3, respectively, as shown on drawing SK-GS-12, Figure A-8.

Recorder/Reproducer

The Recorder/Reproducer converts the graphical data (X position, Y position, erase, and pen up/down signals) to narrow-band FM channels

in a single audio channel. These are recorded on an audio cartridge tape deck. When the cartridge is played back, the Recorder/Reproducer performs the inverse function, reproducing the graphical data from the recorded FM channels. The Recorder/Reproducer contains compensating circuits which eliminate the effects of wow and flutter in the tape deck.

The Recorder/Reproducer is remotely controlled by the FCO Push Button Control. Normally, the Recorder/Reproducer will be set in "RECORD" mode. In this mode it produces audio tones from its graphical inputs for recording upon the cartridge tape deck or for transmitting through an appropriate RF link. If the FCO turns on the "GRAPHICS PLAYBACK" push button, the Recorder/Reproducer is now converted to the "REPRODUCE" mode, in which it will convert audio data to graphical information. If the pen is put down when the unit is in "REPRODUCE" mode, however, the Recorder/Reproducer instantly switches to "RECORD" mode, and will display the live data in preference to the recorded data. Lifting the pen will allow the unit to switch back to "REPRODUCE" mode.

The Recorder/Reproducer is arranged in such a way that live graphics from the FCO pass through a conversion from graphics to audio tones in the transmitter portion of the Recorder/Reproducer, and are reconverted to graphics in the receiver portion. This eliminates effects of d. c. offset and drift in the unit.

Converter Control

The Converter Control is physically housed in the same unit as the Video Keyer to reduce package size. The Converter Control receives graphical information from the Recorder/Reproducer and processes that information before conveying it to the Scan Converter. The circle generator which generates the cursor circles and level

shifters for changing line intensity while writing circles are contained in the Converter Control. The output of the Converter Control is fed to the Scan Converter. The schematic diagram for the Converter Control is drawing D-E209-11, Figure A-9.

Scan Converter

The Scan Converter consists of a Tektronix R4501 Scan Converter, modified to INTERAND TELESTRATOR standards, and converted to 875 line operation. The Scan Converter receives the graphical data from the Converter Control and writes the data into an internal memory. The memory is then read out at video rates. Appropriate blanking and synching signals are added to the information, yielding a composite black-and-white video signal in which white levels correspond to written areas and black levels to unwritten areas. The memory itself is a direct-view storage tube; thus, the graphics image is continuously presented upon the face of the Scan Converter. The Scan Converter video is synchronized externally to incoming video by means of composite synching and blanking signals from the Genlock.

The output of the Scan Converter is a video signal with a one-bit grey scale black-white graphics picture. To superimpose this picture upon the background, a video insert keyer is used, which performs a real-time switch between the background video and a selected level.

The Vertical Drive signal from the Scan Converter consists of pulses which occur at a 60 Hz rate and are crystal controlled. These pulses are utilized for synchronization of the 28V d.c. /110V a.c. 60 Hz inverter.

Video Keyer

The Video Keyer is housed in the same enclosure as the Converter Control. This package performs the function of actually inserting

the graphical information on the video feed from the Scan Converter onto the background video from the Graphics Distribution Unit. This is accomplished by a real-time switch of the video from background feed to a preset level.

Internally, as may be seen on drawing C7212-38, Figure A-10, the video from the Scan Converter is compared in level against a reference in a fast comparator. This reference, called the Clip Level, is set by a potentiometer on the front panel of the TASP package. Written areas in the Scan Converter video cause the output of the comparator to change states. An internal FET switch in the Video Keyer is controlled by this output, switching from background video to a second reference, called the White Level, which sets the grey scale point for graphics. This control is also remoted to the front panel of the TASP package. Thus the output of the Video Keyer consists of the background video upon which graphical data of a desired grey level is written.

Genlock

The Genlock is a Grass Valley Group, Inc. synch locked generator which receives video from the GDU and derives synch and blanking pulses for the Scan Converter. These pulses are time-advanced from the synch and blanking intervals of the incoming video, but synchronized in frequency and phase. The advancement in time is easily adjustable. It allows compensation for cable lengths and group delay in the equipment in the TASP package through which background and keyed video must pass. The synch and blanking pulses are also routed to the Processing Amplifier for use in that section of the Video Processing System.

Without a video input, the Genlock will act as a high stability free-running source of synch and blanking signals for the Scan Converter. The system will therefore continue to function without an 875

line video source and may be checked out independently.

Processing Amplifier

The Processing Amplifier receives the video from the Video Keyer and processes that video before distribution. The Processing Amplifier strips synch and blanking from the video and reinserts those same pulses regenerated from Genlock outputs. The pulse regeneration is performed because, in general, it is the synch and blanking pulses which suffer the greatest deterioration in a video system and adversely affect the stability of the output signals.

In addition, the Processing Amplifier contains many options which may be used to improve the subjective quality of the outgoing video. These controls, adjustable at the front panel of the Processing Amplifier, control stretching, white clip, synch level, and gain. They may be used to optimize the intelligibility of the outgoing video. All are easily adjusted, since front panel controls allow convenient switching between processed and non-processed video out.

Distribution Amplifier

The Distribution Amplifier is a video buffer amplifier, with a single input and four outputs. Video data originating in the Processing Amplifier provides the input. The outputs of the Distribution Amplifier are wired to triaxial connectors at the rear of the TASP package. These video feeds are connected to the Graphics Distribution Unit for routing to the on-board monitors and VTR as required. The only controls provided within the Distribution Amplifier are d. c. level and Video Gain.

It should be noted that although many controls are provided in the Video Processing Unit of the TASP package, these controls are rarely in need of adjustment beyond initial set-up. These controls are intended to be "set-and-forget" and in general should not be adjusted once the Target Annotation System has successfully been set up and

put into service.

Tape Deck

The audio tones transmitted by the Recorder/Reproducer are routed to the input of a Spotmaster Model 500 BR/S broadcast quality cartridge tape deck. When the Target Annotation System is operating, and the tape deck is switched to "RECORD" mode and started, the graphical annotations of the FCO are recorded upon the cartridge as FM audio tones. These tones may be played back (and the graphical information recovered) by switching the tape deck to "PLAY" mode, pushing "GRAPHICS PLAYBACK" at the FCO Push Button Control, and starting the tape deck.

The tape deck utilized is a cartridge type to facilitate tape storage and handling, at the loss of quick edit capability. In-flight editing, however, is not operationally useful, and transfer to reel-type conventional machines for editing may be accomplished later if desired.

The cue track of the tape deck has been modified so that a cuing tone is continuously written upon the cue channel when data is recorded upon the cartridge. (Conventionally, only a burst upon start-up is written). In addition, the cue channel sense amplifiers and trip circuits have been altered to operate in "RECORD" position and are prevented from operating in "PLAY" mode. Furthermore, the positions of the read and write cue heads have been interchanged, positioning the cue playback head in front of the cue track record head in tape travel. Thus, the entire cuing circuit has been converted from a playback to a record aid. In "RECORD" mode, the cue channel is actively sensed for previously recorded data. When such data is sensed (e.g., cartridge is full) the cue track will stop the tape. It cannot be restarted as long as the unit is left in that mode. In playback, however, the tape can be continuously played back for an indefinite length of time.

The cue track insures that data is not written over tape in a cartridge which contains previously recorded information. It automatically notifies the FCO when a cartridge is fully written by means of a "TAPE STOP" alarm light which is provided at the FCO Push Button Control.

Levels of audio tones entering the Spotmaster when recording should be adjusted at the front panel to read zero db with the pen down. At this setting, the playback levels will automatically be of the proper value. It should not be necessary to adjust this control after the unit is once installed and operational.

Since the Spotmaster tape drive motors are line-locked in frequency, a high stability inverter from 28V d. c. to 100V a. c. /60 Hz is provided. This unit, a Nova type 1260-24SP, is capable of delivering 125V a. c. of output power. In addition to the Spotmaster tape deck, the Position Decoder and all Grass Valley gear (Genlock, Processing Amplifier, and Distribution Amplifier) are supplied by the output of this inverter.

The input +28V d. c. supply to this unit passes through a labeled 10 amp circuit breaker mounted upon the front panel of the TASP package and supplies output power to a plug-in strip. The stability of the 60 Hz frequency is assured by means of externally synchronizing the inverter. A 60 Hz signal from the Scan Converter internal crystal clock is connected to the synch input terminals of the inverter.

The 400 Hz 110V a. c. source for all components of the TASP package not supplied by the output of the 28V d. c. /110V a. c. inverter is also routed through a 10 amp breaker, appropriately labeled and installed at the front panel. At any time that it is desired to disconnect the INTERAND TASP (e. g. , before making cable connections or disconnections) both breakers should be turned off.

Cables

The cabling diagram for the TASP System is provided on drawing SK-GS-10, Figure A-11. As indicated, cables utilized are either tri-axial video cables or multiconductor control cables. The control cables contain 6, 10, 35, or 37 conductors. Six conductor cables run from jack J1 of #1 and #2 Sensor Control panels to jacks J1 and J3 respectively of the GDU. The wiring of these six conductor cables is shown on drawing SK-GS-02, Figure A-12.

Ten conductor cables run between jack J3 of the FCO Push Button Control and jack J2 of the GDU and from jack J4 of the TASP to the VTR. These ten conductor cables are wired as shown on drawing SK-GS-03, Figure A-13.

The 35 conductor cable between jack J2 of the Position Decoder and jack J3 of the TASP package is wired as shown on drawing SK-GS-04, Figure A-14. The 37 conductor cable running from jack J2 of the FCO Push Button Control to jack J2 of the TASP package is wired as indicated upon drawing SK-GS-05, Figure A-15. All triaxial cables are wired as conventional double male types, with the outer shield tied to frame ground.

OPERATIONAL INSTRUCTIONS

The INTERAND Target Annotation System is a comprehensive graphics system designed as an auxiliary package to the AN/ASQ-145 Gunship Video System. It offers at least three significant improvements upon the AN/ASQ-145 system:

1) The ease and precision with which the FCO can point out potential or selected targets to either the IR or LLL TV operator is greatly increased, as the FCO need only circle or indicate the object(s) with his pen to instantly identify them. The INTERAND Target Annotation System inserts the annotations made with the pen directly into the video picture on the FCO monitor; a control provided at each of the sensor positions allows it to display the same annotated picture.

2) Flight notes may be made by the FCO without removing his attention from the video monitor before him. The TASP contains a Graphics Recorder/Reproducer that can store graphical data, such as flight notes, as they are written. It can regenerate the data when recovery is desired. Handwritten notes may therefore be made directly upon the monitor, allowing uninterrupted inspection of the video display. Information closely coupled to the video display may also be recorded upon the video track of the VTR, if desired, independent of its inclusion on the audio tape.

3) The Target Annotation System may be utilized as a graphics transceiver, if an appropriate RF link is provided. Graphics transmission provides three functional advantages over voice transmission. First, communication in poor signal-to-noise conditions is enhanced: INTERAND graphical equipment holds a demonstrable 9 to 15 db edge over SSB and AM voice systems. Second, graphical systems excel in conveying information describing shapes or outlines of objects, reproducing maps, or solving any number of similar communication problems.

Graphics add a certain degree of flexibility that improves the operational efficiency of any communications system. Third, a graphics transmission system provides the advantage of not requiring continual operator attention to successfully receive information. Since the graphics receiver contains a storage device, the receiver may be operated unattended or with minimal attention, unlike a conventional voice link.

Operation of the INTERAND Target Annotation System is sufficiently straightforward that training classes for operators are quite unnecessary. The instructions consist of pre-flight Set-Up Instructions and in-flight Operational Instructions.

Pre-Flight Set Up

Thirty minutes or more prior to flight, +28V d. c. and 110V a. c. /400 Hz should be provided to TASP. Then the following procedure must be followed:

- 1) Turn on both breakers on the front of the TASP package.
- 2) Open the door of the TASP package and verify that the pilot lights on the Scan Converter and Video Processor Rack are illuminated. (Turn on the Scan Converter if necessary.)
- 3) Insert a blank cartridge into the Spotmaster cartridge tape deck. Turn the "RECORD-PLAY" knob clockwise to the "PLAY" position. Move the "READY-RELEASE" knob up to the "READY" position. The left push button, labeled "READY," should illuminate. Turn the "RECORD-PLAY" knob counterclockwise to the "RECORD" position. Put the pen down upon the FCO monitor and adjust the "A" channel level control for a reading of zero db.
- 4) Push the "GRAPHICS ON" switch in the FCO Push Button Control to the off (non-illuminated) position. Verify that the LLL and IR TV displays are functioning normally and properly.

Pre-Flight Set Up is now complete. It is necessary to maintain

power (+28V d.c. and 110V a.c.) to the TASP until flight time.

Operational Instructions

In flight, it is not necessary to make adjustments or handle gear in the TASP package, except to replace tape cartridges when required. All other functions are remotely controlled at the TV, IR, and FCO consoles.

The FCO indicates targets or areas to either of the sensor operators by selecting a line style (solid, dotted, or dashed) or sliding circle with the Push Button Control and writing upon his monitor. The sensor operator, when so instructed by intercom, pushes the "GRAPHICS ON" switch to "on." He will then see the same display as the FCO. Positions and outlines are therefore much more quickly relayed than by mere verbal description. The FCO may store the graphics upon the video track of the VTR, if he desires, by pushing the "VIDEO RECORD GRAPHICS" switch.

He may store flight notes on the audio cartridge tape deck by pushing the "TAPE STOP" button. This button is illuminated when the cartridge has stopped running and functions as an on-off switch as well as an indicator. The graphical information is stored on the audio tape, ready for later extraction. If the "TAPE STOP" button lights and pushing it does not restart the cartridge, the cartridge has been fully recorded. It should be replaced with a new, blank cartridge.

To replace a cartridge:

- 1) Move the "READY-RELEASE" knob in the Spotmaster in the TASP down to "RELEASE."
- 2) Pull out the cartridge, label and store it.
- 3) Insert the new cartridge.
- 4) Move the "READY-RELEASE" knob back up to the "READY" position.

While playing back graphical data when airborne is not generally useful, it can be done. The procedure is the same as that used when data recovery is accomplished on the ground.

- 1) Push the "solid line" button and "GRAPHICS PLAYBACK" button in the FCO Push Button Control.
- 2) Insert the appropriate cartridge into the tape deck.
- 3) Switch the "RECORD-PLAY" knob clockwise to "PLAY."
- 4) Start the tape. The graphical information is displayed upon the FCO monitor.

Graphics Transceiver operation is accomplished by inserting the cable from the RF link into the 10 pin connector (J4) at the rear of the TASP package and pushing the "GRAPHICS PLAYBACK" button. When the pen is not touching the front of the FCO monitor, the Target Annotation System may receive data from the RF link. Transfer to transmit mode occurs automatically when the pen touches the monitor; the graphical data is then transmitted from the FCO through the RF link to the remote graphics transceiver. Both received and transmitted graphics are displayed upon the FCO monitor.

Adjustments

The INTERAND Target Annotation System has been designed to operate without requiring that the user set any controls other than push buttons. However, some controls are provided to allow convenient adjustment for individual preference or to optimize clarity of the graphics presentation. Two of these—the "CLIP LEVEL" and the "WHITE LEVEL"—are located on the top panel of the TASP package. Both of these remotely control the Video Keyer within the TASP unit. The "CLIP LEVEL" is set to optimize the clarity of the graphical data, and once set, requires adjustment only at intervals of 3 to 6 months. The "WHITE LEVEL" controls the shade—from dark black to bright

white—of the written graphics. This setting is dictated only by clarity and user preference. Both the "CLIP LEVEL" and "WHITE LEVEL" controls contain locking nuts.

The FCO Push Button Control contains two position controls for alignment of the written graphics with the tip of the pen. The "X POSITION" control translates the drawn graphics left or right from the pen position; the "Y POSITION" control translates the drawn graphics vertically with respect to the pen tip. These controls are adjusted as required to suit individual taste and to compensate for drift, if any, within the Model 504 Position Decoder. Like the other controls, the "X POSITION" and "Y POSITION" controls contain locking nuts to insure that settings are maintained.

CIRCUIT DESCRIPTION, 504 POSITION DECODER

The Model 504 Position Decoder is a compact, self-contained module, designed for use with low-impedance slate materials, such as perforated or solid stainless steel. The cabling and connector configuration of the Model 504 are arranged so that it may be used interchangeably with any other standard TELESTRATOR components associated with a low-impedance type slate.

Internally, the Model 504 Position Decoder is constructed using two printed circuit boards. Most of its circuitry is installed on the Main Board, with a Control Panel Board just behind the front panel performing the trace alignment functions of those front panel controls. Functionally, the package may be conveniently subdivided into three major groups: the Power Supply circuits, the Slate Driver circuits, and the Position Decoding circuits. Each of these groups will be discussed in turn, referring to numbered components on drawing C7212-26 Figure A-16.

Power Supply

Alternating current power is supplied to transformer T1 through fuse F1. T1 is provided with a split primary, allowing either 110V a. c. or 220V a. c. input and is designed to be operable with sources from 50 to 400 Hz. The output of T1 is a center-tapped 24V a. c. winding, which is connected to rectifying diode bridge B1. Smoothing filter capacitors C31 and C34 are connected to the respective positive and negative 12 volt outputs of B1.

Raw +12V d. c. is supplied to pin 30 of connector J1, providing a power source for auxiliary equipment. Also, the +12V d. c. is provided to IC J11, a 723 type integrated circuit voltage regulator. The 723 regulator is a first-order feedback amplifier which drives the output voltage, at pins 3 and 4 to that voltage provided at pin 5. The

voltage at pin 5 is set to be +5 volts. Q12 is a series pass transistor which boosts the current capability of IC J11. R45, a current sense resistor, is selected to provide an over-current shutdown at 1.2 amps. The +5V d.c. output of the regulator supplies all electronics in the Model 504 and is also supplied to pin 31 of connector J1 for auxiliary equipment.

The negative supply is regulated in a similar manner by IC J12 and associated components. The circuit differs since the 723-type voltage regulator is now operated as a negative regulator, requiring an exchange of regulated output and ground terminals. The voltage at pin 7 is controlled by two voltage dividers, R46 with R47 and R48 with R49, to be -5V d.c. Series pass transistor Q13 buffers the current output capability of IC J12 and R51 provides short-circuit limiting. The regulated -5V d.c. output is distributed to all linear circuits in the Position Decoder.

Slate Driver

Slate drive pulses originate with IC J3, an NE565 integrated phase-locked loop. This PLL may, if desired, be externally synchronized through a synch circuit consisting of the components between the "EXT SYNCH" jack and pin 2 of IC J3. Since IC J3 is a phase-locked loop, it locks itself to the frequency of the incoming signal. This feature may be used to eliminate low beat-frequency effects between the Position Decoder and external electronic devices. Pulses coupled through C1 are divided by two by a J-K flip flop (half of IC J1) and coupled into IC J3, which locks itself in frequency to 4 times the frequency of the signal applied to the "EXT SYNCH" jack.

If no inputs are connected to this jack, the PLL will free run as an oscillator, the frequency of which is controlled by R5. This is the usual mode of operation; rarely is it necessary or useful to externally

synchronize the slate drive frequency.

The square waves from the PLL, IC J3, pass through transistor Q1, which performs the role of buffer and level shifter. The output of Q1 is used to generate fast pulses for pen up/down determination and is also applied to the input of three cascaded divide-by-two J-K flip flops. The outputs of the last two of these J-K flip flops (IC's J1A and J2B) are applied to 4 two-input NAND gates (IC J4A-D) to generate 4 non-overlapping time intervals. The outputs of each of the gates consists of a 25% duty cycle pulse train, arranged so that the pulses appear sequentially at pins 3, 6, 11, and 8 of IC J4.

Each of these pulses pass through a 2N3638 current booster and 2N1711 transformer driver. The 2N1711 transformer drivers are turned on and current passes from the +5V supply through corresponding halves of the slate transformers in sequence. Since current in the transformer primary flows, for example, in one direction when Q5 is on and in the opposite direction when Q3 is on, the transformer output is a symmetric square wave. The non-overlapping nature of the four drive pulses results in a system which alternatively generates a square wave in the X axis transformer (driven by Q3 and Q5) and in the Y axis transformer (driven by Q7 and Q9). The secondaries of these transformers are multiple single turn windings attached directly to the slate so that the output square waves are applied alternately across the slate X and Y axes.

Position Decoding Circuits

These circuits perform the function of converting those signals appearing on the pen as it touches the slate to d. c. X and Y coordinate levels. This is achieved by measurement of the difference between the signal amplitude appearing at the pen and that at a reference point. This reference may take the form of a tab soldered to a corner of the slate or may be artificially generated from resistor networks. Both pen

and reference signals pass from the input jack through a 68 pf capacitor and 100K resistor to a high-impedance operational amplifier.

The pen lead also contains a pen up/down pulse coupling network. Square waves from the transistor buffer, Q1, are differentiated by C35 and R20. The resulting pulses are coupled into the pen by variable capacitor C19. When the pen is down, the pen will short-circuit the pulses from C19 by virtue of the extremely low slate impedance. When the pen is up, fast pulses of considerable amplitude (adjustable by C19) appear upon the pen lead. These fast pulses do not appear on the reference line, however.

The reference and pen signals are both passed through high-impedance operational amplifiers connected as voltage followers, IC's J5A and J5B respectively. The outputs of these in turn are applied differentially to IC J6, a 733 type wideband differential input-differential output video amplifier. The gain of IC J6 may be adjusted by R59.

The output of IC J6 consists of square waves of alternating amplitude when the pen is down. When the pen is up, the output is a square wave upon which high-amplitude fast pulses are superimposed. The existence or absence of these pulses is utilized to determine pen up/down status. The device that makes this determination is IC J7, a dual retriggerable one-shot. The high-pass filters constructed of C21-R23 and C22-R24 effectively block all signals except the pulses. As long as the pulses occur, both one-shots in IC J7 continue to remain in a triggered condition and the outputs at both pins 4 and 12 remain held at a logical zero. When the pulses no longer appear, the pen has been pressed against the slate. The output at pin 4 will rise to a logical one approximately one millisecond after the pulses are absent. This output is called "Z PROMPT" and is connected to pin 20 of connector J2. The output at pin 12 of IC J7 will rise to a logical one approximately 100 milliseconds later, and is called "Z DELAYED." This delayed

signal is applied to pin 2 of IC J8, where it is ANDed with \bar{Z} control signals on pin 1 of IC J8. The \bar{Z} control signals are continuously held to a logical one, except in dash mode or dot mode, in which case a symmetric or non-symmetric square wave appears. The resultant signal—delayed \bar{Z} with dot/dash/line information—is called + \bar{Z} out and is wired to pin 4 of connector J2.

The differential outputs of IC J6 are also conducted into two synchronous rectifiers constructed of JFET's Q10 and Q11. Q10 is turned on for 75% of the slate drive cycle, and turned off for that remaining portion in which the +X wire (connector J7, pin 3) is energized. Thus the output of C14 is shorted to ground except during one half of the X drive cycle. The result is that Q10 acts as a synchronous half-wave rectifier for decoding the X portion of the data picked up by the pen when pressed against the slate. Similarly, Q11 is turned on except for that portion of the drive cycle in which the +Y wire (connector J7, pin 17) is energized. Thus Q11 acts as a synchronous half-wave rectifier for decoding the Y portion of the data sensed by the pen. Therefore, the inputs to IC's J9A and J9B are half-wave rectified signals for the X and Y axes, respectively.

IC's J9A and J9B achieve the required smoothing of the outputs of the synchronous rectifiers to d.c. X and Y positional signals. Each of these amplifiers acts as a low pass filter with a bandwidth of approximately 35 Hz. The voltage gain at d.c. of these amplifiers is approximately 10. The voltages appearing at pins 12 and 10 of IC J9 swing between zero and about 1.0 volts as the pen is moved from extreme left to extreme right or from top to bottom.

The outputs of IC J9A and J9B, which correspond to X and Y positions, are now brought to the small Control Panel Board mounted immediately behind the front panel. It is on this board that trace

alignment is accomplished. Trace alignment controls consist of those components used to align the written graphics with the pen position at every point on the screen. These are the only controls in the 504 Position Decoder that are accessible from the front panel. There are three controls associated with each axis. For X axis alignment, the "Horizontal Position", "Horizontal Gain", and "Lean" controls are utilized. One uses first the "Horizontal Position" to align the dot position horizontally until the drawn dot is vertically aligned with the pen, positioned at the center of the slate. Then the "Horizontal Gain" is adjusted until vertical alignment is achieved at both right and left extremes of the pen position. With these accomplished, the "Lean" control is adjusted until no horizontal dot movement occurs as the pen is moved from top to bottom of the right or left slate edge.

For Y axis alignment, the "Vertical Position", "Vertical Gain", and "Tilt" controls are adjusted. One first uses the "Vertical Position" to move the drawn dot at the center of the slate until it is aligned with the pen's horizontal position. "Vertical Gain" then is adjusted, with the pen at either the extreme top or bottom of the slate, until the dot is again aligned with the horizontal position of the pen. Now the "Tilt" control is adjusted until no vertical motion in the dot position is seen as the pen is moved from left to right along either the top or bottom of the slate.

All six of these controls are associated with two operational amplifiers, IC J1-A and J1-B on the Control Panel Board. The "Horizontal Gain" and "Horizontal Position" are simply gain and offset controls of the X-axis amplifier, IC J1-A. The "Lean" control sums a small amount of Y position correction into the X axis; similarly the "Tilt" control sums a small amount of X position correction into the Y axis. The outputs of these amplifiers are the corrected, and final, X and Y positional data signals. The "X OUT", as the X positional data is called, is wired

to pin 1 of connector J2. The "Y OUT" signal is wired to pin 15 of connector J2. These signals are usually adjusted to provide a signal swinging from -0.5 volt to +0.5 volt as the pen is moved from extreme to extreme in each of the respective axes.

CARD DESCRIPTIONS, RECORDER/REPRODUCER

Graphics Input Card

The Graphics Input Card is positioned to the extreme left in the Recorder/Reproducer. Its schematic diagram is drawing C7212-24, Figure A-17. Functionally, it consists of filters, differential line receivers, and track-and-hold amplifiers. The filters are formed by two 8.2K resistors and three 0.1 μ f capacitors in each of the X and Y position signal paths. The X position signal enters the card on pins P and S; the Y position signal enters on pins H and L.

From here, each signal passes through a differential line receiver, consisting of IC's 2A and 1A respectively. The net gain, from the input of the card to the output of these amplifiers is unity in each channel.

A track-and-hold amplifier in each channel follows, fabricated from a 2N5458 junction FET and an additional operational amplifier. When a pen-down signal (logical TTL 1) appears at pin M, the JFET's are turned on and IC's 2B and 1B operate as tracking amplifiers. A pen-up signal occurring at pin M causes the JFET's to be turned off and the amplifiers switch into holding until a new pen-down signal occurs. The benefit of the track-and-hold amplifiers is that a certain amount of instantaneous skipping in the pen may be tolerated without adversely affecting graphics quality. The output signals from the track-and-hold amplifiers appear respectively on card pins T and F for X and Y axes.

Voltage Controlled Oscillator (VCO) Card

The VCO card, schematically shown on drawing C7212-25, Figure A-18, produces the narrow-band FM audio tones that are modulated by X and Y positional data from the Graphics Input card. The VCO card is located to the immediate right of the Graphics Input

card. Functionally, the VCO card consists of two d. c. level shifters, two VCO's, a power supply, and a thermal stabilizer.

The level shifters consist of IC's U1A and U2A for X and Y axes, respectively. The level shifting that these operational amplifiers perform is used only to shift the X and Y input signals to the VCO's by an amount equal to the shift in the output d. c. level of the on-card power supply due to component value drift (if any). The signals out of these level shifters then are conducted to the VCO IC's.

The VCO IC's are two SE566T IC's which are installed on a brass thermal sink in the center of the card. These high-linearity voltage-to-frequency converters are mounted on the thermal sink to eliminate drift. Their gains and frequencies are adjusted such that at pin 14 (the X output channel) the frequencies generated are $2300 \text{ Hz} \pm 6\%$. This yields 2438 Hz and 2162 Hz as frequencies corresponding to extreme left and right pen positions. For the Y axis, the VCO is adjusted for $1700 \text{ Hz} \pm 6\%$, producing 1802 Hz and 1598 Hz at the extreme bottom and top pen positions.

In order to simplify testing, the VCO's are operated with a d. c. supply of +2 and -10 volts, instead of symmetric supplies. This allows one to obtain center-channel frequencies at the output of the VCO's when a ground is placed at the controlling pin of the VCO. The +2V supply is generated on the card with a 723 voltage regulator IC and output buffer transistor Q5. The +2V supply is also conveyed to the level shifters which precede the VCO's.

The VCO's used display a marked drift in frequency with temperature, which is eliminated by locating them on the brass thermal sink previously mentioned. The temperature of this sink is fixed by means of a thermal stabilizer, composed of a thermistor, amplifier, and a heater transistor. The stabilizer works as a high-gain first-order

feedback system, which holds the temperature constant to within 0.1°C .

Transmit Logic Card

The Transmit Logic card, drawing C7212-27, Figure A-19, consists of a reference tone generator, TTL level shifters, and an Erase tone generator. Also provided, but not utilized in the TASP Recorder/Reproducer, are a Σ tone generator and electronic capability for division by two of all frequencies.

The reference tone generator consists of a crystal-controlled oscillator (IC 6A & B) and two divide-by-sixteen TTL counters which are cascaded to produce a total division by 256. The reference tone thus generated is a highly stable 1300 Hz tone. This tone is used in the compensating circuits when reconstructing graphical information from audio tape recordings. This tone eliminates the effects of tape deck wow and flutter.

TTL level shifting is performed by 2N3904 transistors Q1 and Q2, which convert the output of the VCO to levels more suitable for TTL logic. The Erase tone generator, a 2N4870 unijunction oscillator Q6, generates pulses at a 2200 Hz rate, when a ground on card pin J releases hold-down transistor Q4. These fast pulses are then passed through a divide-by-two J-K flip flop to obtain a square wave, which appears as a 1100 Hz signal at pin P.

Transmit Output Card

The Transmit Output card is located to the immediate right of the Transmit Logic card and is the final card in the signal flow path. The schematic for the Transmit Output card is C7212-28, Figure A-20. Its principal sections are a mixer, filter, power amplifier, and transmit control. All tones to be transmitted are prefiltered and then summed in IC 1. The prefiltering circuitry consists of a single-pole simple RC roll-off in each of the four channels to prevent nonlinearities in the

summing amplifier, IC 1. The output of IC 1 is passed through a passive low pass filter of relatively high quality with a break frequency of 3 kHz. From this filter the composite tones are conveyed to an audio power driver, an NE540L with an a. c. gain of 100. The output of this driver is routed through isolating transformers (for phone line operation) and a level control (for tape recording).

The control circuits in the Transmit Output card control connection to and disconnection from the phone lines for telephone links and provide keying lines for radio transmitter control. These circuits consist of relays K1 and K2, driver IC's 3B and 4A, an R-S flip flop, and a UJT time delay generator. When the pen is down, a logical 1 appears at pin F of the card, which sets the flip-flop so that K1 is energized, and K2 is de-energized. When the pen is lifted, the hold-down on 2N4870 UJT Q1 effected by IC 3A is released and the UJT begins to time out. When it times out, it generates a pulse that resets the R-S flip-flop. This causes K1 to de-energize and K2 to energize. The transfer occurs immediately upon pen-down; only when the pen is raised does the delay occur.

Power Supply Card

Identical Power Supply cards are used in both the transmitter and receiver sections of the Recorder/Reproducers. Schematics are shown on drawing C7212-29, Figure A-21. Three 723 IC voltage regulators and three crowbar overvoltage protection circuits are included on this card. The IC regulators regulate -12 volts, +12 volts, and +5 volts. Small on-card transistors (Q2, Q5, & Q8) and high-power transistors external to the card boost the capacity of these IC regulators.

To protect the rest of the electronics package in the Recorder/Reproducer, SCR overvoltage crowbars are utilized. These consist of SCR's with zener diodes between the output voltage and the SCR gate. Zener diodes (D1, D2, and D3) with breakdown voltages of approximately

130% of the corresponding nominal supply voltages are used. In event of regulator failure or shorted series pass transistors, the output voltage will begin to rise to the unregulated raw d. c. level. When 130% of nominal supply level is reached, however, the zeners will conduct, firing the SCR's, and the power supply will be shut down. Without the SCR crowbar protection, a single regulator failure might easily destroy 40% of the integrated circuits in the electronics package.

Audio Input Card

The Audio Input card lies to the extreme left of the Graphics Receiver portion of the Recorder/Reproducer. This, the first card in processing audio tones from a tape recorder or radio into graphical data, is schematically shown on drawing C7212-30, Figure A-22. Functionally, it consists of an amplifier, two filters and two tone decoders. IC 1A is the amplifier, capable of receiving a single-ended or balanced (through transformer T1) audio tone, with a voltage gain of 5. Two active filters follow this stage, one of which is tuned for 1100 Hz (\mathbb{Z} -axis); the other is tuned for 800 Hz (Erase). Each filter consists of a cascaded pair of constant-Q adjustable frequency two-pole active filters, stagger-tuned to reduce ringing. The outputs of these filters are connected to 1100 Hz and 800 Hz tone decoders. These \mathbb{Z} and Erase tone decoders (IC's 4 and 5 respectively) consist of phase-locked loops with quadrature lock detectors. They generate a logical zero when tones of the proper frequency and phase stability appear at their inputs.

The logic-level outputs of the tone decoders are connected to pins U and W for \mathbb{Z} and Erase commands respectively. In addition, the buffered composite audio tones are brought out on pin H.

Filter Card

The Filter card, drawing C7212-31, Figure A-23, is positioned immediately right of the Audio Input card. It provides a driver, passive

filter, and clipper for FM data carried in X axis, Y axis, and the reference channel. The driver consists simply of an a. c. amplifier with a voltage gain of 5 and a 1K source resistor for the filter. Each channel is provided with its own driver. The passive filters are 1K input, 1K output, 3 pole pair Butterworth bandpass types which have center frequencies of 1300 Hz, 1700 Hz, and 2300 Hz for reference, X axis, and Y axis channels respectively. These correspond to IRIG data channels 5, 6, and 7; 3 db bandwidths of $\pm 7.5\%$ are used in accordance with IRIG standards.

Following the filters, a clipper is used in each channel, formed by placing side-by-side diodes in the feedback path of the operational amplifier. The output from the clipper is a 1.4 volt peak-to-peak square wave. Outputs from the clippers leave the card on pins V, W, and X for X and Y axes and reference, respectively.

Phase Locked Loop (PLL) Card

The PLL card, schematic C7212-33, Figure A-24, is the card in which the frequency-to-voltage conversion is actually performed. It contains three IC PLL's, three differential amplifiers, a voltage regulator, and a thermal stabilizer. The IC PLL's (SE 565K type) are mounted on a brass thermal sink in the center of the card. The incoming data from the Filter Card is a. c. coupled into pin 2 of the PLL's (IC's 1, 2, & 3). The VCO's within the PLL's are set to free run at twice the incoming data frequency. The VCO output is routed to the PLL Logic card, where its frequency is digitally divided by two, and returned to the phase detector input of the PLL IC. The VCO output is on pin 4 of the PLL IC and the phase detector input is pin 5 of the same IC (IC's 1, 2, & 3). The reason for the division by two is that a quadrature lock detector is utilized in the Lock Logic card, and quadrature rotation requires a double frequency input, if it is accomplished digitally.

The detected output of the PLL IC appears at pin 7, but contains

a large d. c. offset. This offset is eliminated by passing the output through a differential amplifier, the other input of which is connected to pin 6 of the PLL IC, an internally generated reference voltage. The differential amplifiers are IC's 4A, 4B, and 5B for the X axis, Y axis, and reference channels respectively. In addition, an independently adjustable offset control for these differential amplifiers is provided by R7, R20, and R29 respectively. These controls are adjusted such that at center frequency, the d. c. output voltage is zero volts. The d. c. output voltages appear upon pins 18, 17 and 16 for X and Y axes and reference respectively.

To provide a VCO output voltage swing that is readily convertible to -6 TTL voltage levels, an on-board voltage regulator is provided, generating an 8 volt d. c. supply. This is accomplished by IC 6B and pass transistor Q1. IC 6B is simply a buffered operational amplifier with a voltage gain of $-2/3$. This guarantees that the negative supply tracks the positive supply. The -8 volt supply is also connected to the differential amplifiers, minimizing drift.

The thermal regulator consists of a thermistor, amplifier, and a transistor (Q2) heater, connected to the same brass thermal sink that the PLL IC's are mounted on. This regulator operates as a first-order feedback control system with very high gain, giving thermal regulation to better than 0.1°C . (The amplifier portion of the regulator is located on the PLL Logic card.)

PLL Buffer Card

Immediately right of the PLL card lies the PLL Buffer card. This card, schematically shown on drawing C7212-32, Figure A-25, is quite simple. It consists of a track-and-hold amplifier with independent d. c. gain and a. c. roll off frequencies and the required switching electronics, for each channel. The d. c. outputs of the PLL card

appear at pins T, H, and F for the X axis, Y axis, and reference channels respectively. The X and Y axes channels are provided with gain-setting potentiometers. They then pass to the track-and-hold amplifiers, constructed of 2N5458 JFET's and operational amplifiers. These are controlled by a lock signal from the Lock Logic card. If the system is in lock, the JFET's are turned on and the outputs of amplifiers 2A and 2B follow the input voltages. When an unlocked signal appears, the JFET's are turned off and the outputs are held at a fixed level until the unlocked condition ceases. In addition, R28 and R29 adjust a.c. roll-off break frequencies of the tracking amplifiers when tracking.

The reference channel behaves slightly differently; instead of holding its output at a previous value, as is done for X and Y axes, Q3 switches it to zero volts in an unlocked condition (Q3 is turned on when unlock occurs). The reference channel is known to have a most probable value of zero volts.

The level switching for JFET's Q1, Q2, and Q3 is provided by IC's 1A and 1B. The output signals of the PLL Buffer card appear at pins N, M, and L.

PLL Logic Card

The PLL Logic card, schematically shown on drawing C7212-34, Figure A-26, provides several functions: low-level to TTL signal conversion, Z axis and Erase logic control, and digital division by two. The low-level to TTL conversion is accomplished by amplifiers 1B, 4A, and 4B. Each of these is fed the corresponding output of the filter card (X axis, Y axis, and reference respectively). These amplifiers convert the 1.4 volt peak-to-peak square wave into a low rise time square wave, swinging from zero volts to five volts, suitable for TTL logic. The output of these level converters appears upon pins 13, P, and 14

respectively.

Z and Erase logic control functions further process the logic-level outputs of the Audio Input card. Both functions are inhibited by the lack of a lock signal upon pin L. (IC's 3A and 3D provide a negative to positive logic conversion for Z and Erase signals.) For the Z axis, a logical zero received at pin 6 of IC 3 triggers an SN74122N (IC6) one shot and the output is inhibited for the duration of the timing interval. At the end of this interval (approximately 50 milliseconds), the Z output is enabled. The delayed response allows the graphical data channels to settle before writing commences. The erase signal is also enabled by the lock signal, but a timing interval is not involved.

Digital division by two of the VCO output frequencies is performed by J-K flip flops IC's 2A, 2B, and 5. The VCO output signal from the PLL card is passed through a 2N3904 transistor to buffer and convert to TTL levels. The output is routed to the clock terminal of the corresponding flip-flop, which is connected to toggle. The signals (both buffered VCO outputs and those outputs after division) are required by the Lock Logic card for quadrature signal generation.

The remaining function performed by the PLL Logic card involves IC 1A. This operational amplifier is the heater amplifier for the thermal stabilizer located on the PLL card. The other components of the heater assembly are located on the PLL card and have already been discussed.

Lock Logic Card

The Lock Logic card determines if the PLL's in the receiver are actually in or out of lock. Being in lock requires that a signal of proper frequency and phase stability is present at the inputs of all three phase-locked loops. The Lock Logic card makes the determination

by a measurement of the phase error signal in real time. This is accomplished by quadrature signal generation.

The quadrature signals are generated by J-K flip flops. These are IC's 4A, 4B and 5A on drawing C7212-35, Figure A-27, for X axis, Y axis, and reference signals. The VCO center frequency (twice data channel frequency) is inverted and connected to the clock input. The VCO frequency, divided by two, is applied to the K input of the J-K flip flop. Finally, the J input of the flip flop is connected to its own \bar{Q} output. Since the square wave at the VCO frequency, applied to the clock input, has been inverted, its negative-going transitions occur in the middle of the high and low portions of the square wave applied to the K input. The \bar{Q} and J signals are therefore toggled at a point in time translated by one-fourth period from the K input signal. The output of the J-K flip flop is therefore a square wave, of a frequency identical to, but removed in phase by 90° from the signal generated by digitally dividing the VCO output frequency by two.

If the phase-locked loop is in phase, this quadrature signal and the incoming data signal will differ in phase only by an amount dictated by phase offset and normal tracking phase error, the sum of which is quite small. Out of lock, the phase error is in general much larger and can be utilized to obtain out-of-lock detection.

The phase error is determined by means of an exclusive OR gate, which generates a logical one only if its inputs differ. Thus the output of the exclusive OR gate is "one" during a real time interval proportional to the phase difference between the VCO and incoming data. The exclusive OR output is compared against a time interval generated by a one-shot (IC's 7A, 7B, and 8A) in a NAND gate. The output of this gate (6A, 6B, and 3A) is normally high, but negative-going pulses will be produced if the phase error time interval exceeds the time interval

produced by the one shot. All of these pulses are then passed through three-input NAND gate IC 6C, the output of which will rise to a logical one if any of the inputs falls to zero.

The output of IC 6C is thus a series of positive-going pulses if any of the channels is out of lock. A retriggerable one-shot (IC 8B) is triggered into a timing state upon receiving positive-going pulses. If this one-shot is timing, the system is unlocked. When it times out, IC 3B generates a low condition, producing a high condition at pin 8 of IC3. This output is the lock line, which indicates an in-lock condition with a TTL one and an out-of-lock state with a logical zero.

Error Compensation Card

The Error Compensation card is the last card in the signal flow of positional data. The schematic for the Error Compensation card is drawing C7212-36, Figure A-28. It is used to compensate for wow and flutter in tape decks. This is accomplished by subtraction and division. First-order correction is achieved by subtraction of the reference data from positional data in IC's 1A and 2B. These amplifiers are connected as summing amplifiers, but the reference data is inverted in IC 1B before summing. At the output of these amplifiers (IC's 1A and 2B) the X and Y data are completely corrected at center positions and partially compensated at off-center positions.

Complete compensation is realized by the analog dividers which follow, IC's SO-1 and SO-2. The X and Y positional data is divided by a divisor composed of the reference voltage and a d. c. offset. The divisor is generated in IC 2A. After division, both X and Y positional data are completely compensated for wow and flutter.

Alignment of the Error Compensation card is quite difficult and in general should not be attempted in the field. The general sequence is (1) calibrate the multipliers, (2) set subtractors for complete center-

position compensation, and (3) adjust offsets and gains at IC 2A for corner compensation after division.

To insure independence of calibration from the power supply levels, on-board regulators are used. An IC regulator, IC5, regulates incoming +15V to +10V. An operational amplifier (IC 4A) provides a tracking negative supply derived from the output of IC5.

Record Logic Card

The Record Logic card, drawing C7212-37, Figure A-29, is the only card which is common to both transmitting and receiving portions of the Recorder/Reproducer. This card provides all analog switches to route audio tones into and out of the Recorder/Reproducer.

Audio tones for the receiver may arrive from three sources. First, an analog summing amplifier (IC 1A) generates a composite signal from the raw X, Y, Reference and Erase tones. This feature is used when multispeed recording is desired. If multispeed recording is not used, card edge pins 18 and 6 are tied together, and the output of IC 1A consists of the transmitted composite audio. The two other audio sources are local audio playback and a remote source. The local audio playback is connected to pins 10 and 11 of the card and usually conveys audio tones played back from a tape deck located near the Recorder/Reproducer. The remote jack, brought to pins 12 and 13 of the card, may receive audio from any external source.

The options of selecting an audio source are controlled by logic signals on pins 15, 16, and 17 respectively. A TTL "1" on pin 16 will cause the receiver to receive only tones which are being transmitted by the transmitter portion. A "0" on this pin allows reception of either local or remote external sources, selected in turn by controls at pin 15. If the pen is down, however, transmitted tones will have priority. The local audio is buffered by IC 1B and remote audio by IC 2A. All

receiver tone routing is accomplished by COSMOS transmission gates IC's 5A, B, C, and D.

The transmitted output tone is simply gated by IC 6B and buffered by amplifier IC 2B before being transmitted. Gain controls on IC 2B allow setting of line output levels.

Problem	Procedure
1. All TASP package pilot lights are out; system non-functional.	1. Check power supply to TASP package. 2. Check TASP package connections. 3. Check TASP package status.
2. Scan Converter operates; FCC push button control, tape deck and video processing rack not operating.	1. Check power supply to Scan Converter. 2. Check Scan Converter connections. 3. Check Scan Converter status.
3. Scan Converter operates; FCC push button control, video processing rack not operating.	1. Check power supply to Scan Converter. 2. Check Scan Converter connections. 3. Check Scan Converter status.
4. Scan Converter operates; FCC push button control, video processing rack not operating.	1. Check power supply to Scan Converter. 2. Check Scan Converter connections. 3. Check Scan Converter status.

TROUBLESHOOTING GUIDE

This Troubleshooting Guide is designed as useful assistance to qualified technicians performing corrective maintenance on the INTERAND Target Annotation System. Causes of failure are listed in order of decreasing probability.

<u>Problem</u>	<u>Probable Cause of Failure</u>
All TASP package pilot lights are out; system non-functional.	<ol style="list-style-type: none">1. Front panel breakers of TASP package off.2. +28V d. c. and 110V a. c. not supplied to TASP package. See SK-GS-13, Figure A-30.3. Connector J1 of TASP package not connected.
Scan Converter operates; FCO push button control, tape deck, and video processing rack not operating.	<ol style="list-style-type: none">1. +28V d. c. breaker on front panel of TASP package off.2. +28V d. c. not supplied to TASP package.3. 110V a. c. /60 Hz power strip in TASP package turned off. See SK-GS-13, Figure A-30.4. 110V a. c. /60 Hz power strip in TASP package not connected to output of 28V d. c. /100V a. c. inverter.5. 28V d. c. not connected to input of 28V d. c. /110A a. c. inverter.6. Failure of 28V d. c. /100V a. c. inverter.
FCO push button control, tape deck, video processing rack lights are on, Scan Converter will not come on.	<ol style="list-style-type: none">1. 110V a. c. breaker on front panel of TASP package off.2. 110V a. c. /400 Hz not supplied to TASP package.3. 110V a. c. /400 Hz power strip in TASP package turned off. See SK-GS-13, Figure A-30.4. 110V a. c. /400 Hz power strip in TASP package not connected to front breaker.

Scan Converter and tape deck both on; FCO push button control will not light, except for "TAPE STOP."

1. 35 pin cable not plugged into J3 of TASP package. See SK-GS-10, Figure A-11.
2. 35 pin cable not plugged into J2 of 504 Position Decoder.
3. Pins "d", "e", and "f" of J2 not plugged into 110V a.c./60 Hz distribution strip in TASP package. See SK-GS-07, Figure A-31.
4. 35 pin cable from 504 Position Decoder not plugged into FCO Push Button Control. See SK-GS-10, Figure A-11.
5. Fuse blown in 504 Position Decoder.

All pilot lights in system come up, no graphics are visible on any monitor, graphics are visible on front of Scan Converter. FCO Push Button Control lights illuminate.

1. Triax cable from J6 of GDU to J5 of TASP package not connected.
2. Scan Converter switched to "WRITE ONLY" mode. Scan Converter should be in "READ AND WRITE" mode.
3. "CLIP LEVEL" control on front of TASP package improperly set.
4. Processing Amplifier in Video Processing rack badly maladjusted.
5. Scan Converter output not cabled to Video Keyer.
6. Processing Amplifier and Distribution Amplifier improperly cabled.
7. Processing Amplifier or Distribution Amplifier failure.
8. Cable within TASP package from front panel TASP package to "REMOTE" jack of Converter Control/Keyer not plugged into "REMOTE" jack.

All pilot lights in system come up, no graphics are visible on any monitor or on front of Scan Converter. FCO Push Button Control lights illuminate.

1. "X POS" and "Y POS" controls on FCO Push Button Control misadjusted.
2. Scan Converter switched to "READ ONLY" mode. Scan Converter mode switch should be set to "READ AND WRITE" mode.

3. Crowbarred power supplies in the Recorder/Reproducer. One should remove the Recorder/Reproducer front panel, pull out power supply cards, wait 2 minutes, reinsert cards. Do not exchange cards.
 4. Scan Converter X and Y positioning controls misadjusted. These front panel Scan Converter controls must be set at 12 o'clock.
 5. 10 pin connector from Position Decoder not plugged into back of FCO Monitor.
 6. Faulty pen and/or fault in pen wire.
 7. Scan Converter "INTENSITY" front panel control set too low. Normal setting is approximately 3 o'clock.
 8. Cable within TASP package from J3 on rear panel to J3 of Converter Control/Keyer module not connected.
 9. Cable within TASP package from J4 of Converter Control/Keyer to J1302 of Scan Converter not connected.
 10. Fuse(s) in Recorder/Reproducer blown.
 11. Cables to and from Recorder/Reproducer in TASP package not connected.
 12. One or more defective slate drive transistors in Position Decoder.
- Pen position not aligned with drawn dot over entire screen.
1. Misadjustment of Trace Alignment controls. "X POS" and "Y POS" are mounted upon FCO Push Button Control. "X GAIN," "Y GAIN," "LEAN," and "TILT" are mounted upon front panel of Position Decoder.
 2. One or more open secondary windings on slate drive transformers. See C7212-26, Figure A-16.

Some switches in FCO Push Button Control do not illuminate.

1. Burned out bulbs.
2. Failure of Push Button Logic board within Push Button Control.

TV and/or IR Sensor positions "GRAPHICS ON" switches do not light.

1. 10 pin cable from J3 of FCO Push Button Control to J2 of GDU not connected.
2. Corresponding cable(s) from Sensor Control Unit(s) not connected.
3. Missing or burned out bulbs in switch(es).
4. Wiring fault within GDU.
5. Wiring fault within sensor control unit(s)

TV and/or IR Sensor positions do not view annotated display when local "GRAPHICS ON" switch is on. Video seen is conventional display; switch(es) illuminate.

1. Faulty cable between Sensor Control Unit and GDU.
2. Reed relay failure within GDU.
3. Faulty wiring within GDU.

TV and/or IR Sensor positions go blank when "GRAPHICS ON" switch is on.

1. GDU triaxial cables improperly connected.
2. Open coaxial cable within TASP package between output of Distribution Amplifier and J5, J6, J7, or J8.
3. Open wiring within GDU. See SK-GS-12, Figure A-8.

Turning off "GRAPHICS ON" switch on FCO Push Button Control does not restore AN/ASQ-145 to conventional operation (without graphics).

1. Triaxial cables to GDU improperly connected.
2. Reed relay failure within GDU.
3. Wiring shorted within FCO Push Button Control. Turn off 28V d.c. breaker on front panel of TASP package. If system now is restored, wiring is faulty. See SK-GS-13, Figure A-30.

Dotted or dashed lines do not function.

1. Faulty IC6 within Push Button Logic card of FCO Push Button

Sliding (cursor) circle appears as dot.

- Control. See C7212-26, Figure A-16.
2. Open pin "D" in cable between J2 of Position Decoder and J3 of TASP package. See SK-GS-04, Figure A-14.
3. Open wire between pin 4 of J3A of Recorder/Reproducer and PLL Logic card of receive section of Recorder/Reproducer.

1. Faulty gate in IC 13 of Push Button Logic card of FCO Push Button Control. See D7212-39, Figure A-3.
2. Open conductor in 35 pin cable between Push Button Control and Position Decoder.
3. Open conductor in J2-J3 cable between Position Decoder and TASP package. See SK-GS-04, Figure A-14.
4. Relay failure within Converter Control/Keyer module.
5. Circle size controls in Converter Control open or badly misadjusted.

Erase is continually tripped while writing.

1. Improper settings of active filter in Audio Input Card of Graphics Recorder/Reproducer.
2. A tripping of Erase only occurs on playback of graphics; the playback level controls are set too high.

Erase does not function.

1. Erase tone oscillator on Transmit Logic card of Recorder/Reproducer improperly set.
2. Open conductor in Erase line wiring, from FCO Push Button Control through the Position Decoder to the Recorder/Reproducer in TASP package.
3. Improper settings of active filters in Audio Input card of Recorder/Reproducer.

No pen-up command (a line is written whether or not pen is pressed against slate).

No pen-down command (X and Y deflections are seen, but only at very high Scan Converter intensity settings; no intensity shift upon pen down).

4. 567 tone decoder in Audio Input card of Recorder/Reproducer is improperly set.
5. Open conductor in cable within TASP package between Recorder/Reproducer and Converter Control/Keyer.
6. Open conductor in cable between J5 of Converter Control/Keyer and J1304 of Scan Converter.
7. Failure of erase function within Scan Converter.

1. Intensity control on Scan Converter set much too high.
2. Misadjustment of R24 within Position Decoder.
3. Failure of IC J4 within Position Decoder. See C7212-26, Figure A-16.
4. R59 in Position Decoder set for too much gain of IC J6. See Circuit Description, 504 Position Decoder.
5. Failure of IC3 or relay K1 in Transmit Output card of Recorder/Reproducer.
6. Open "LOCK" line between Lock Logic card and PLL Logic card of Recorder/Reproducer.
7. "LIMIT-LINEAR" switch within Scan Converter switched to "LINEAR." See Scan Converter Manual.

1. Misadjustment of R24 within Position Decoder. See Circuit Description.
2. C19 within Position Decoder improperly set.
3. Failure of IC J7 within Position Decoder.
4. Center frequencies of either VCO card or PLL card of Recorder/Reproducer improperly set.

Graphics do not play back from cartridge tape deck.

Graphics roll or flip with respect to background video.

5. X and Y position(s) on Scan Converter improperly set; correct control positions are at 12 o'clock.
 6. Failure of any IC on Lock Logic card of Recorder/Reproducer.
 7. Failure of IC3 or relay K1 in Transmit Output card of Recorder/Reproducer.
 8. Shorted "LOCK" line between Lock Logic card and PLL Logic card of Recorder/Reproducer.
-
1. Controls improperly set; see appropriate section of Operations Instructions.
 2. Playback level much too low on tape deck.
 3. Audio lines between Recorder/Reproducer and tape deck not connected or exchanged.
 4. Failure of IC 1, 4, or 5 of Record Logic card of Recorder/Reproducer.
 5. Wiring to "GRAPHICS PLAYBACK" switch of FCO Push Button Control faulty. See SK-GS-08, Figure A-5.
 6. Faulty tape cartridge.
 7. Failure of playback head or playback amplifier within tape deck. See Tape Deck Manual.
 8. Playback or record head wiring disconnected within tape deck.
-
1. Genlock not connected to Scan Converter.
 2. Open cable between J9 of TASP package back panel and input to Genlock.
 3. Triaxial cable from J6 of GDU to J9 of TASP package not connected or cable open.
 4. Genlock failure. See 940-H Video Processing Manual.

Pen-down tails appear.

1. Improper adjustment of Z-axis delay on PLL Logic card.

Cursor circles write a broad line.

1. Non-store level in Scan Converter improperly adjusted.
2. Cursor line from Push Button Control through Position Decoder open.

Background video quality deteriorates when graphics is turned on.

1. Processing Amplifier badly misadjusted.
2. D. c. restorer(s) in Video Keyer not functioning.
3. Short between inner and outer shield of triaxial cable(s).
4. No termination at input of Processing Amplifier or Distribution Amplifier.
5. Faulty reed relay(s) in Graphics Distribution Unit. See SK-GS-06, Figure A-7.

Bulbs in switch(es) at sensor on FCO consoles experience extremely short life.

1. One or more relay-shunting diodes in GDU open. See SK-GS-06, Figure A-7.
2. Open center tap on secondary of power transformer of Position Decoder.

Target Annotation System cannot receive graphics from RF link.

1. Controls improperly set; see appropriate sections of Operations Instructions.
2. Cable used to connect RF link to TASP package at connector J1 improperly assembled; short between pins B & D must be provided to use RF link. See SK-GS-07, Figure A-31.
3. Audio levels from RF transceiver set much too low.
4. AGC failure in RF receiver portion of link.
5. Faulty wiring between J4 of rear panel TASP package and J1 of Recorder/Reproducer

Remote Graphics transceiver or receiver cannot receive graphics from Target Annotation System through RF link.

Graphics do not write over entire screen.

6. Faulty IC 2, 3, 4, or 5 in Record Logic card of Recorder/Reproducer.
7. Misadjustment of remote Graphics Transceiver X and Y VCO center frequencies.
8. Modulation levels at remote end of RF link set much too low.
9. Open transformer T1 on Record Logic card of Recorder/Reproducer.
10. Remote graphics transmitter not set to provide reference tone.

1. Faulty cable from J4 of rear panel TASP package to J1, Recorder/Reproducer.
2. Faulty IC2 in Record Logic card of Recorder/Reproducer.
3. Cable used to connect RF link with TASP package improperly assembled; see SK-GS-07, Figure A-31.
4. IC3 or relay K1 on Transmit Output card of Recorder/Reproducer failed. K1 provides keying line for transmitter.
5. Modulation levels on RF link either much too high or much too low.
6. Misadjustment of X and Y PLL center frequencies in remote graphics receiver.
7. Failure of Audio Input card or Lock Logic card in remote graphics receiver.
8. Intensity on display unit at remote receiver set too low.

1. "X POS" and "Y POS" controls on FCO Push Button Control misadjusted. Reset X and Y controls on FCO Push Button Control and on Scan Converter.

Jitter in written line on playback of graphics.

2. Misadjustment of X and Y VCO center frequencies.
3. Misadjustment of X and Y PLL center frequencies.
4. Wrong value of timing resistors or capacitors associated with IC's 7A, 7B, or 8A on Lock Logic card of Recorder/Reproducer.
5. PLL(s) in receiver portion of Recorder/Reproducer set to run on third harmonic of incoming data.
6. Misadjustment of "X RAMP POS" and "Y RAMP POS" controls within Scan Converter.

Skipping in written line.

1. Misalignment of cartridge or pinch roller in cartridge tape deck.
 2. Bent capstan in cartridge tape deck. See Tape Deck Manual.
 3. Misadjustment of a. c. roll-off controls in PLL Buffer Card of Recorder/Reproducer.
 4. Misadjustment of Error Compensation card in Recorder/Reproducer. It is not recommended that field adjustments be attempted upon the Error Compensation card.
-
1. Dirty screen on FCO monitor.
 2. Intermittant contact within pen or pen cable.
 3. Stainless steel impressed too deeply into portions of plastic backing of screen.
 4. Misadjustment of C19, R59, or R24 in Positon Decoder.
 5. Intermittant contact in "REF" wire from slate to Position Decoder.
 6. Front panel "INTENSITY" control on Scan Converter set slightly low.

Graphics drift badly.

1. Failure of Transmit Logic card reference tone oscillator and count-down IC's.
2. Chip thermal regulator in either VCO or PLL card failure in Recorder/Reproducer.
3. Failure of reference PLL on PLL card of Recorder/Reproducer.
4. Offset control (R29) for reference channel on PLL card of Recorder/Reproducer misadjusted.

Jitter in written line of live graphics.

1. Gain controls on Transmit Output card of Recorder/Reproducer set too high.
2. Loose tie-down straps on slate drive transformers (installed in FCO monitor behind overlay).
3. Faulty wiring between "X POS," "Y POS," "X GAIN," "Y GAIN," "LEAN, or "TILT" controls and Control Panel Board of Position Decoder.
4. Ripple in +5V d. c. or -5V d. c. supplies in Position Decoder, from failure of any IC within Position Decoder, thereby drawing excessive current.
5. FCO monitor not securely installed.

Excessive "howl" from slate drivers.

1. Frequency of NE565 (J3) in Position Decoder too low. Increase frequency with R5, and readjust "X POS," "Y POS," "X GAIN," "Y GAIN," "LEAN," and "TILT" as required.

Irregular white areas (other than written graphics) appear in output display.

1. Clip level on front of TASP package improperly adjusted.
2. Collimation of Scan Converter improperly adjusted.
3. Background offset, H or V shading in Scan Converter misadjusted. See Scan Converter Manual.

"X POS" and "Y POS" control(s) in FCO Push Button Control have no effect.

1. Failure in 35 pin cable from Position Decoder to J1 of FCO Push Button Control See SK-GS-04, Figure A-14.
2. Faulty wiring within Position Decoder between J1 and Control Board.
3. Potentiometer failure in FCO Push Button Control.

A single vertical line is drawn as pen is moved.

1. Failure of JFET Q10 in Position Decoder.
2. Failure of IC J9A or J1B in Position Decoder. See C7212-26, Figure A-16.
3. Short between X-axis data line and ground in PLL Buffer or Error Compensation card of Recorder/Reproducer.
4. Faulty cable from Position Decoder to connector J3 of TASP package or from Recorder/Reproducer to Converter Control/Keyer within TASP package.
5. Failure of transistors Q2, Q3, or Q5 in Position Decoder.

A single horizontal line is drawn as pen is moved.

1. Failure of JFET Q11 in Position Decoder. See C7212-26, Figure A-16.
2. Failure of IC J9B or J1A in Position Decoder.
3. Short between Y-axis data line and ground in PLL Buffer or Error Compensation card of Recorder/Reproducer.
4. Faulty cable from Position Decoder to connector J3 of TASP package, or from Recorder/Reproducer to Converter Control/Keyer within TASP package.
5. Failure of transistors Q6, Q7, Q8, or Q9 in Position Decoder.

A single non-moving dot is drawn as the pen is moved. Pen up/down signals work.

1. Short within pen lead.
2. Failure of IC J5B or IC J6 within Position Decoder.
3. Failure of IC3 in Graphics Input card of Recorder/Reproducer.
4. Failure of IC1 in PLL Buffer card of Recorder/Reproducer.
5. Failure of IC's 3, 4, or 5 in Error Compensation card of Recorder/Reproducer.

A single moving dot appears as pen is moved.

1. Short between cursor line and ground within Position Decoder, Recorder/Reproducer, or Converter Control/Keyer.
2. Failure of IC 13 on Push Button Logic card of FCO Push Button Control.
3. Improper setting of "STORE LEVEL S. T. B." control within Scan Converter.
4. Scan Converter "STORE-NON-STORE" front panel switch moved to "NONSTORE" position.

Cursor circle appears as an ellipse.

1. Misadjusted circle size controls on Converter Control.
2. "X WRITE SENSITIVITY" or "Y WRITE SENSITIVITY" controls within Scan Converter misadjusted.

Written lines are too wide.

1. "INTENSITY" control on front panel of Scan Converter set too high.
2. "CLIP LEVEL" control on front panel of TASP package incorrectly set.
3. Write beam size (FOCUS and ASTIGMATISM) controls within Scan Converter out of adjustment. Readjust for smallest writing beam size.

4. "X GAIN" and/or "Y GAIN" controls in Scan Converter set too low. Read raster area (illuminated area on front of Scan Converter tube) should cover all of engraved graticule. Adjust controls for full area, reset "X" and "Y WRITE SENSITIVITIES" for fully written area.

APPENDIX A

DRAWINGS, SCHEMATICS, AND DIAGRAMS

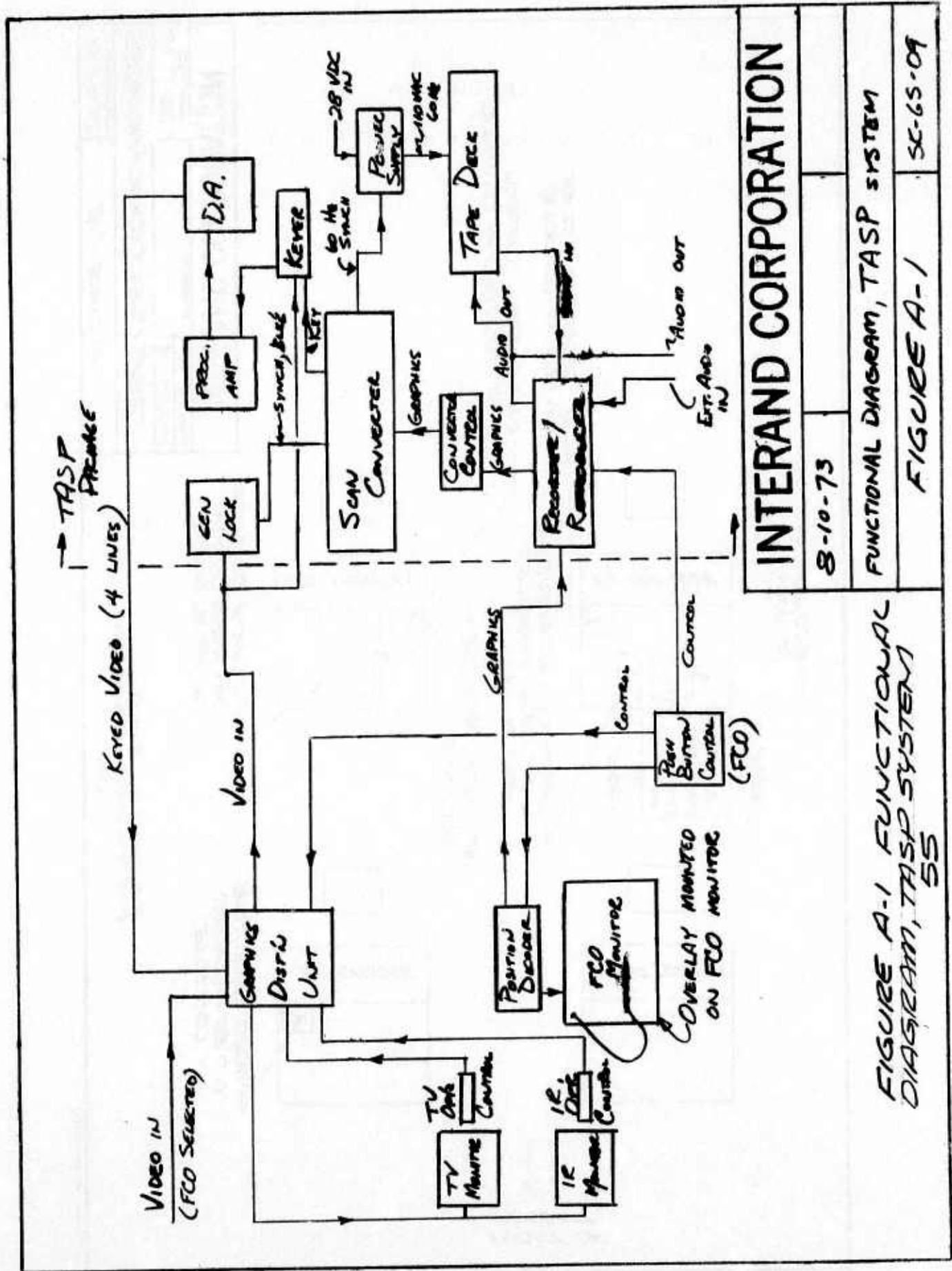

INTERAND CORPORATION

8-10-73

FUNCTIONAL DIAGRAM, TASP SYSTEM

FIGURE A-1

SC-65-09

FIGURE A-1 FUNCTIONAL DIAGRAM, TASP SYSTEM

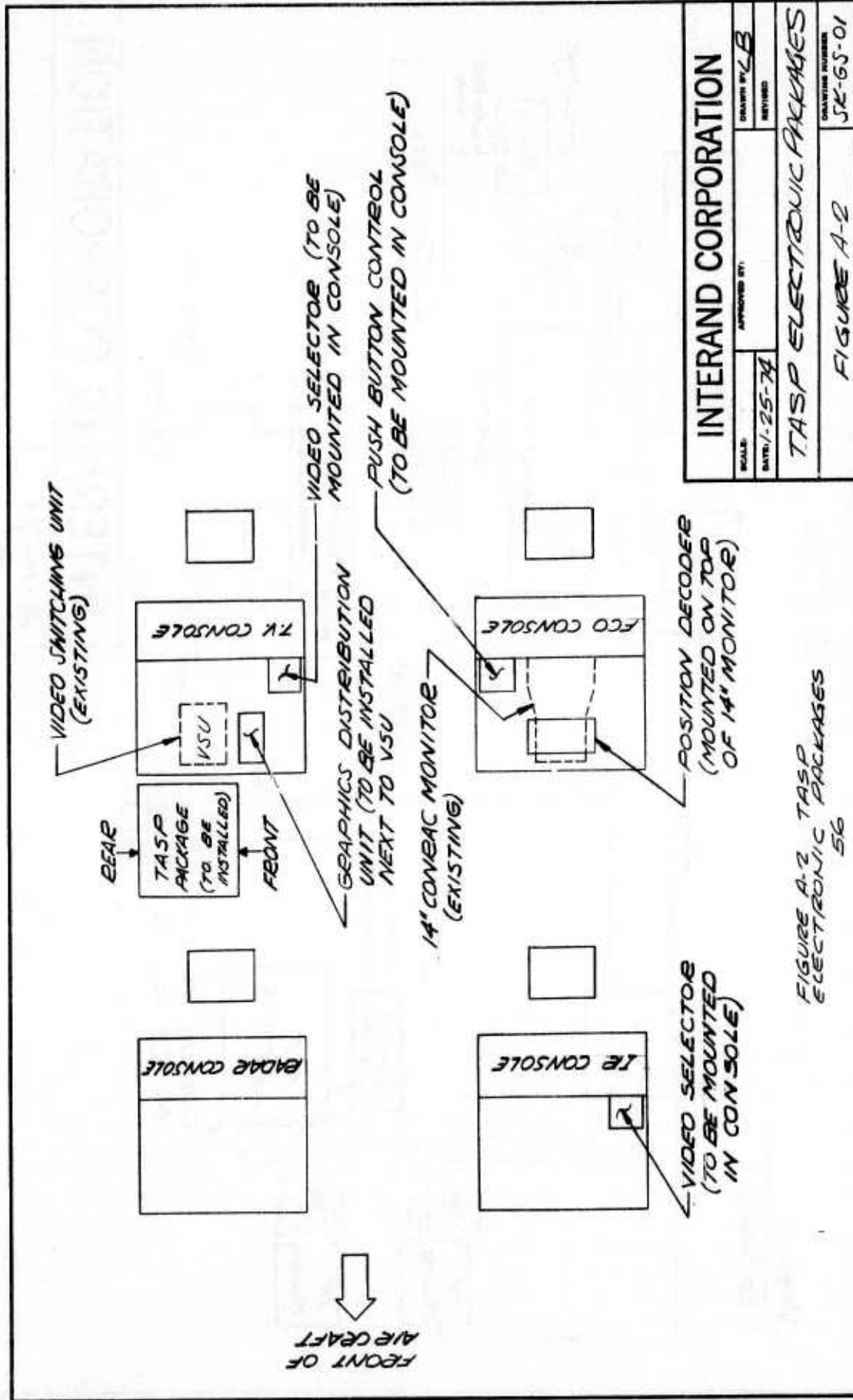

INTERAND CORPORATION	
SCALE	APPROVED BY:
DATE: 1-25-74	DRAWN BY: L.B.
REVISED	
TASP ELECTRONIC PACKAGES	
DRAWING NUMBER	
JK-65-01	
FIGURE A-2	

FIGURE A-2 TASP ELECTRONIC PACKAGES 56

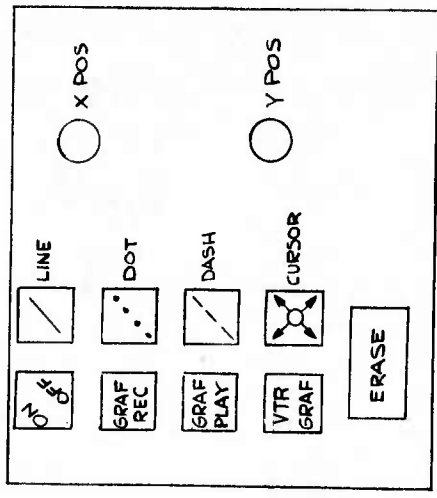
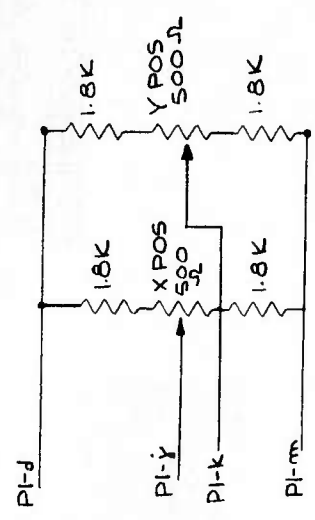
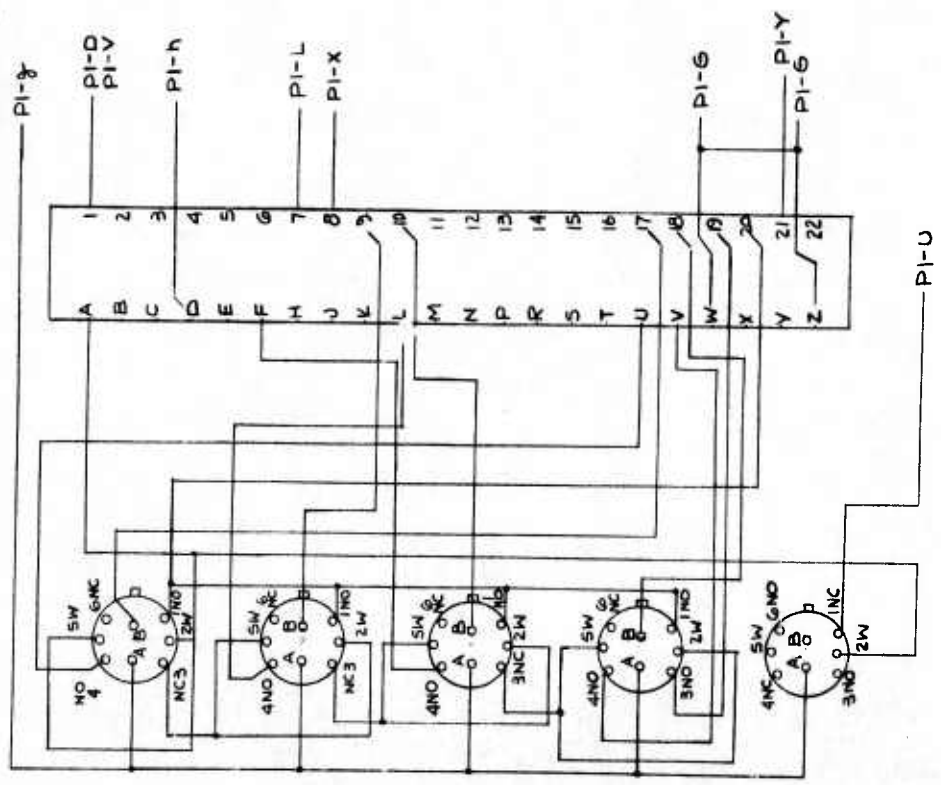

INTERAND CORPORATION

SCALE:	APPROVED BY:	DRAWN BY: LEB	
DATE: 2-18-74		REVISED:	
FCO CONTROL PANEL			DRAWING NUMBER
FIGURE A-3			B7212-40

*FIGURE A-3
FCO CONTROL PANEL
57*

P1-MS3102A-28-15P (35P)
 P2-MS3102A-28-21P (37P)
 P3-MS3102A-18-1P (10P)

GEAF/CS
ON/OFF

GEAF/CS
PLAYBACK

TAPE
STOP

GEAF/CS
RECORD
VTE

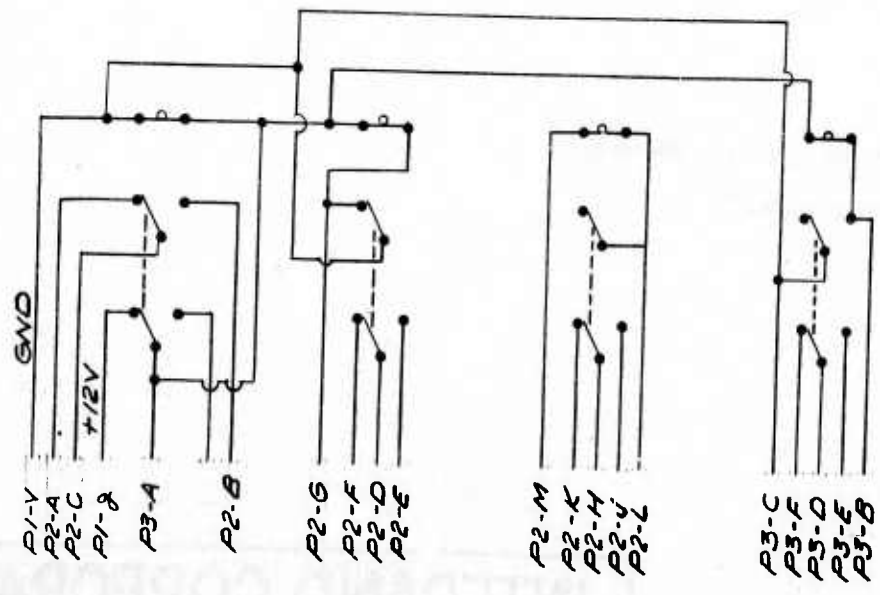
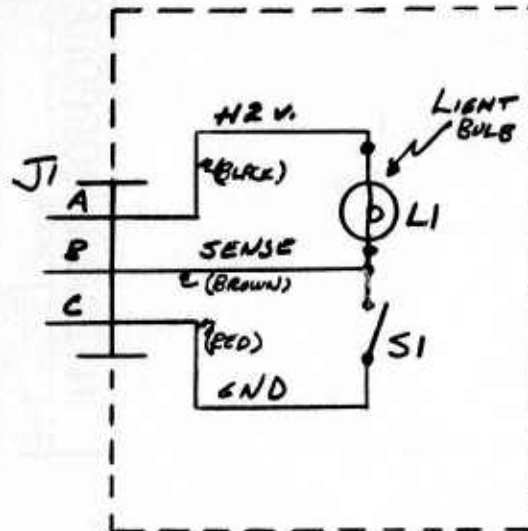

FIGURE A-5 GEAF/CS PLAYBACK
SWITCH F.C.D. PUSHBUTTON CONTROL

INTERAND CORPORATION	
SCALE: —	APPROVED BY: <i>LB</i>
DATE: 1-25-74	REVISED:
GEAF/CS PLAYBACK SWITCH F.C.D. PUSHBUTTON CONTROL	
FIGURE A-5	
DRAWING NUMBER JK-65-08	

E



J1 - MS3102A-14S-6P (6PIN)

SI - CUTLER-HAMMER TYPE SBIDEX491-2 ALTERNATE
ACTION PUSH BUTTON SWITCH

NOTES:

- 1) LENS CAP TO BE ENGRAVED
"GRAPHICS ON"

FIGURE A-6 WIRING
DIAGRAM, SENSOR
CONTROL UNIT

60

INTERAND CORPORATION

B-10-73

WIRING DIAGRAM, SENSOR CONTROL UNIT

FIGURE A-6

SK-6S-11

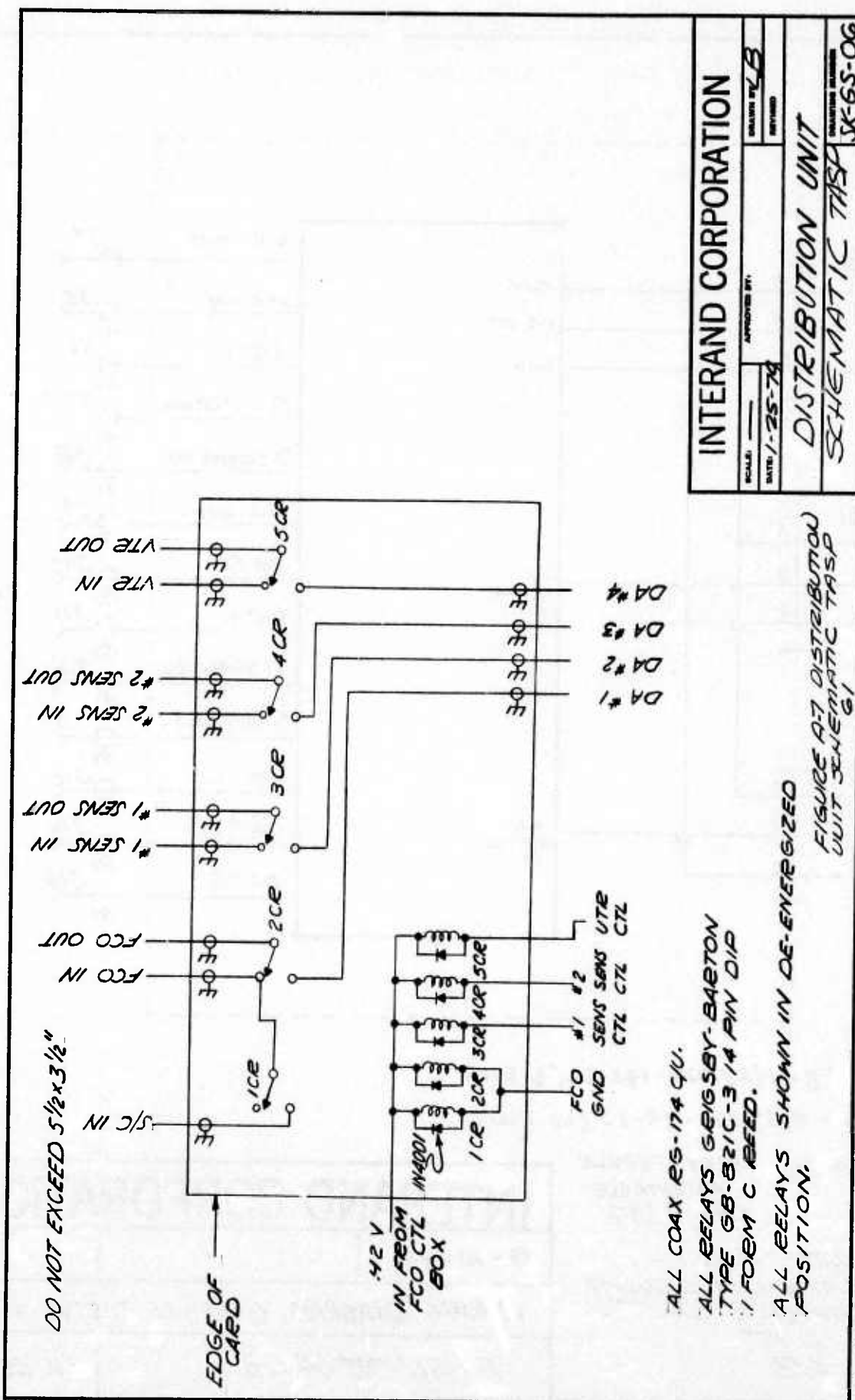

INTERAND CORPORATION	
SCALE: _____	APPROVED BY: _____
DATE: 1-25-74	DRAWN BY: T.L.B.
REVIEWED: _____	
DISTRIBUTION UNIT	
SCHEMATIC TRASP	
INTERAND NUMBER:	JK-6S-06

FIGURE A-7

FIGURE A-7 DISTRIBUTION UNIT SCHEMATIC TRASP

ALL COAX RS-174 Q/U.
 ALL RELAYS GRIGSBY-BARON
 TYPE GB-821C-3 14 PIN DIP
 FOEM C BEED.
 ALL RELAYS SHOWN IN DE-ENERGIZED
 POSITION.

11 CITY PRINTED ON NO. 10000 QUALITY

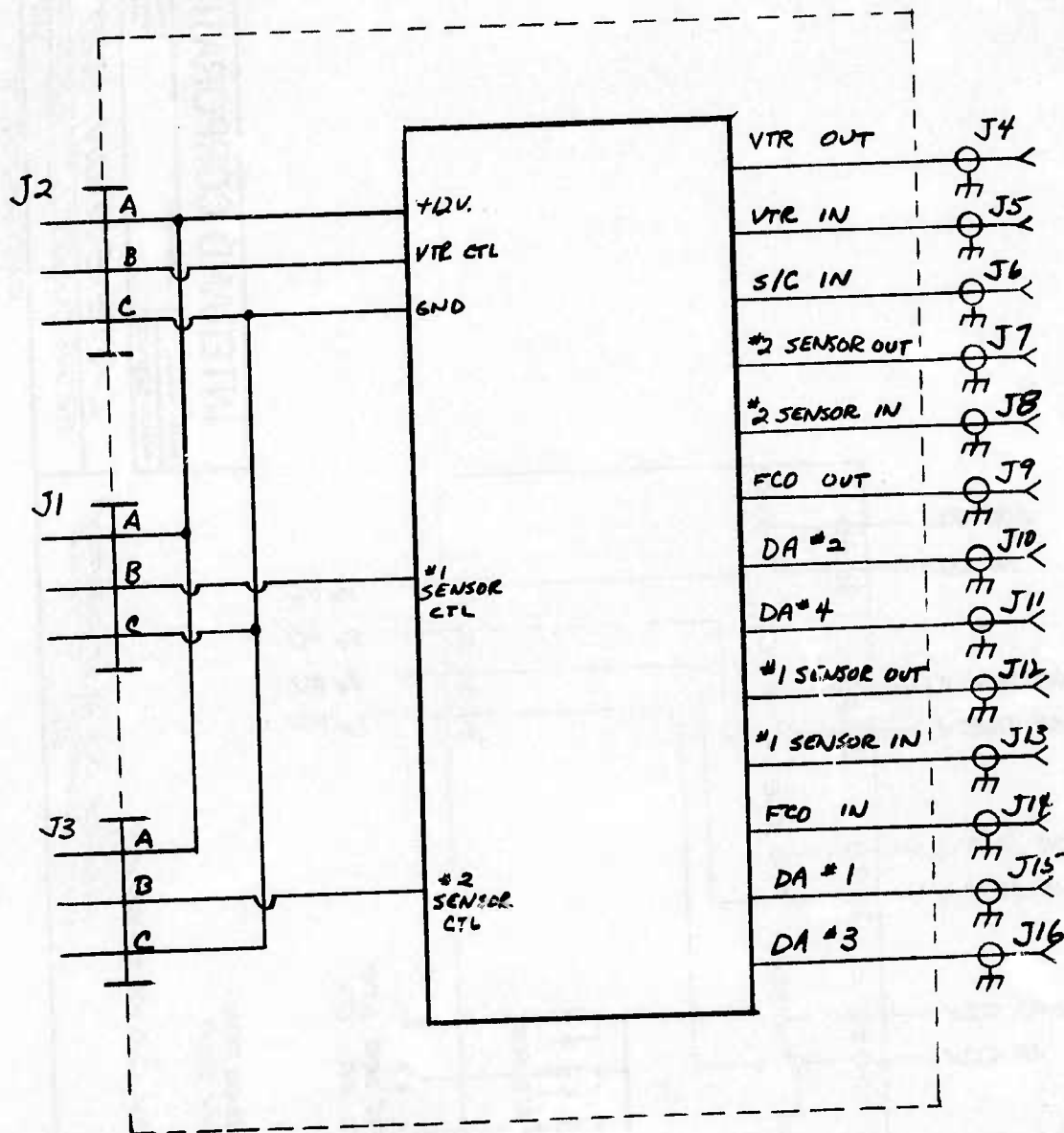

J1, J3 - MS3102A-14S-6S (6 PIN)

J2 - MS3102A-18-1S (10 PIN)

J4 → J16 TRIAX FEMALE
RECEPTACLE
TYPE BJ77

FIGURE A-8
WIRING DIAGRAM
GRAPHICS DISTN
UNIT
62

INTERAND CORPORATION	
B-10-73	
WIRING DIAGRAM, GRAPHICS DISTN UNIT	
FIGURE A-8	SK-6S-12

REV.	REVISIONS	DATE
1	INITIAL DESIGN	11/27/64
2	ADDED C81, C82, C83	12/1/64
3	ADDED C84	12/1/64
4	SEE 209-12, P. 4	12/1/64
5	WAS 39K	12/1/64
6	WAS 100MMHS	12/1/64
7	R1 WAS 47K	12/1/64
8	R4 WAS 47K	12/1/64

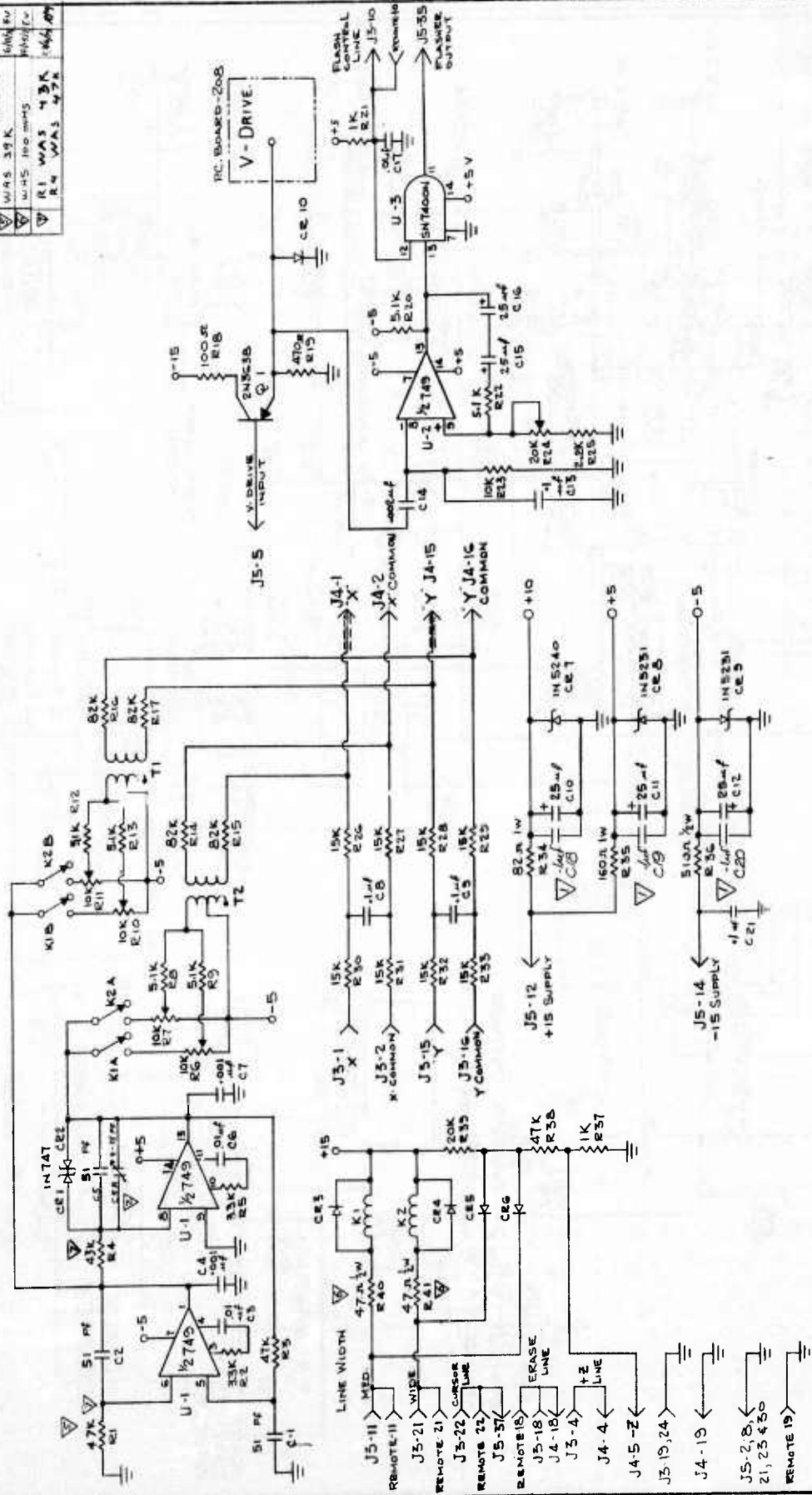

NOTE:
 1. ALL RESISTORS ARE 1/4 W. UNLESS OTHERWISE SPECIFIED.
 2. ALL DIODES ARE 1N5214 UNLESS OTHERWISE SPECIFIED.

FIGURE A-9
 CONVERTER CONTROL SCHEMATIC

U/O MODEL 209 # 9/5

TELESTRATOR INDUSTRIES INC.
 Subsidiary of Instructional Dynamics Inc.
 Chicago, Illinois.

REV.	DATE	BY	CHKD
1	11-10-64		

C-209-11

FIGURE A-9

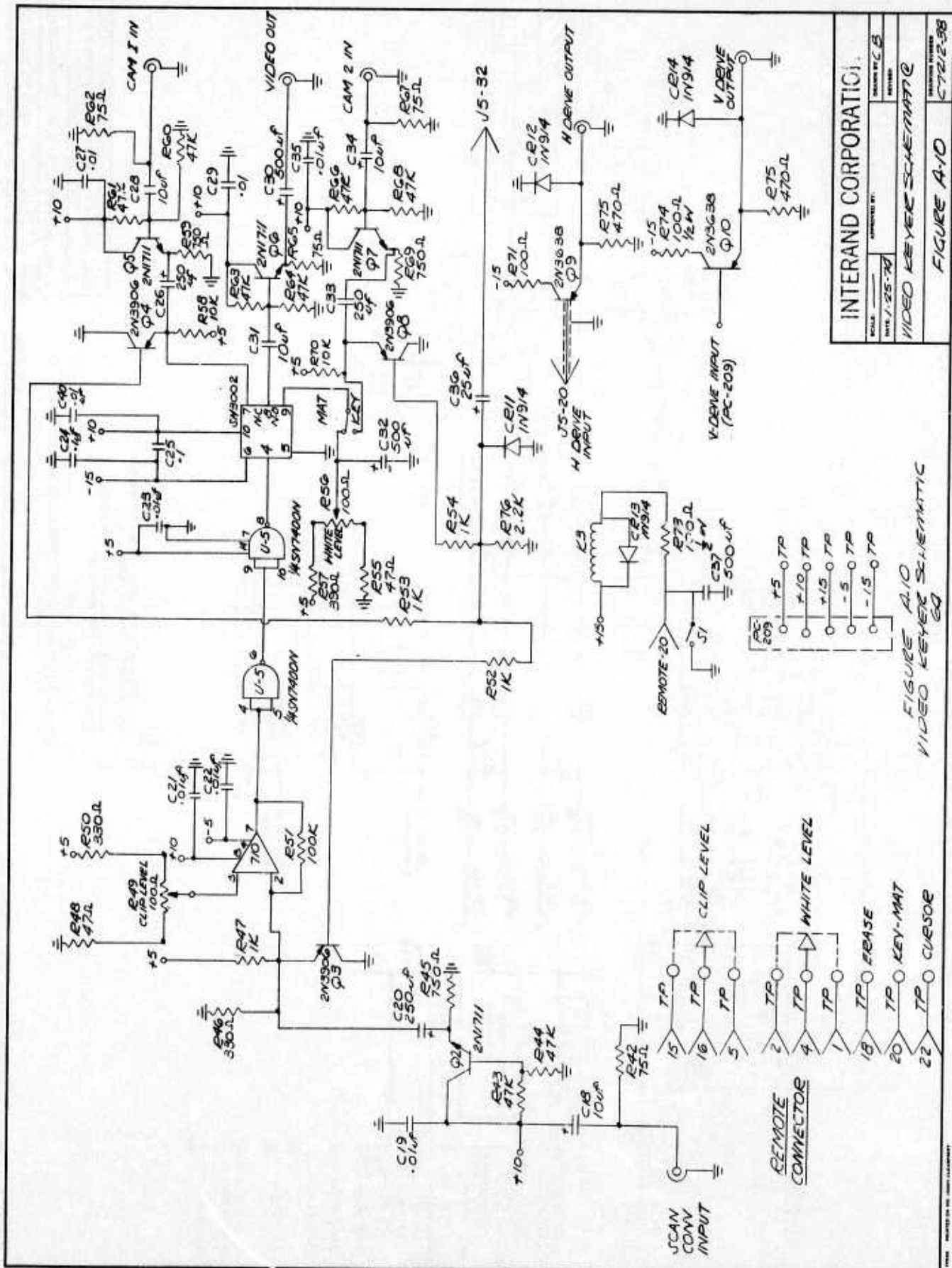
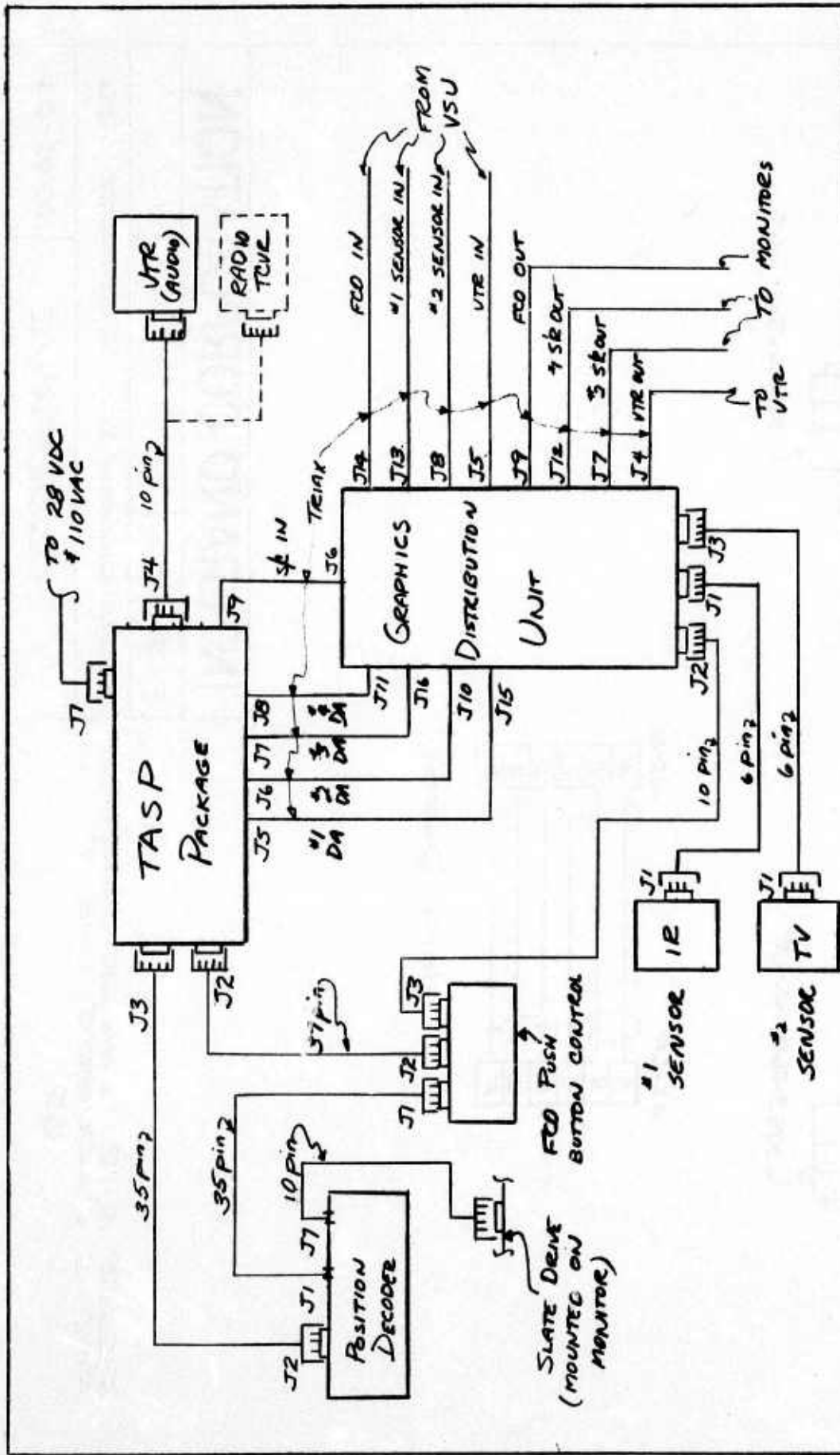

FIGURE A-10
VIDEO KEYSER SCHEMATIC

INTERAND CORPORATION	
DATE: 1/25/70	APPROVED BY: [Signature]
DRAWN BY: C.B.	
REVISION NUMBER: 1702/E-98	

REF: 08700A-2



INTERAND CORPORATION	
7-25-73	
TASP SYSTEM CABLING DIAGRAM	
FIGURE A-11.	SK-65-10

FIGURE A-11 TASP SYSTEM CABLING DIAGRAM
65

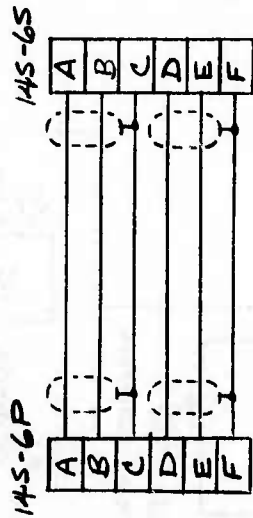
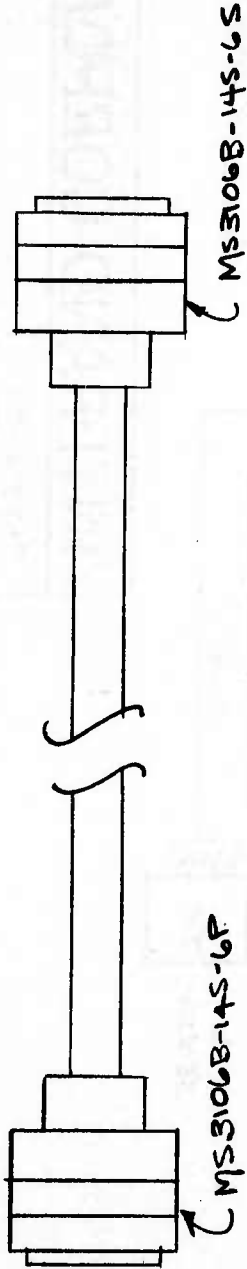

WIRING DIAGRAM

INTERAND CORPORATION	
B-28-73	
WIRING DIAGRAM FOR 6 CONDUCTOR CABLE	
FIGURE A-12	SK-65-02

FIGURE A-12 WIRING DIAGRAM FOR 6 CONDUCTOR CABLE

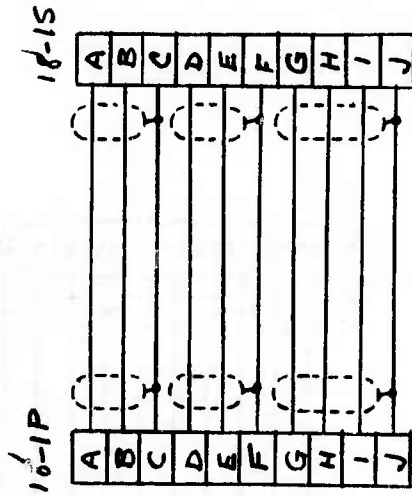
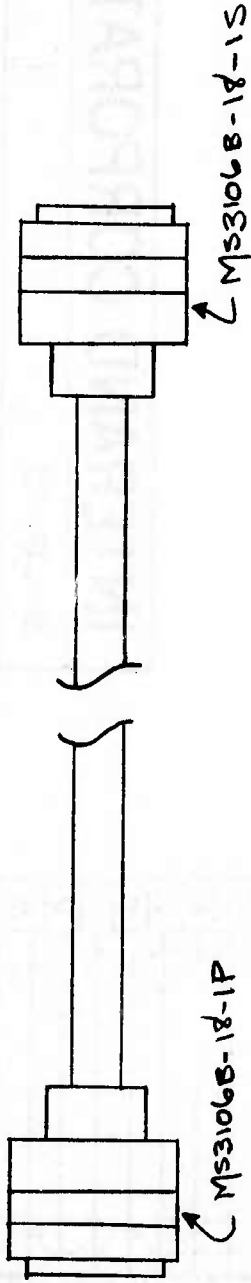

WIRING DIAGRAM

INTERAND CORPORATION	
8-28-73	
WIRING DIAGRAM FOR 10 CONDUCTOR CABLE	
FIGURE A-13	SK-65-03

FIGURE A-13 WIRING DIAGRAM FOR 10 CONDUCTOR CABLE

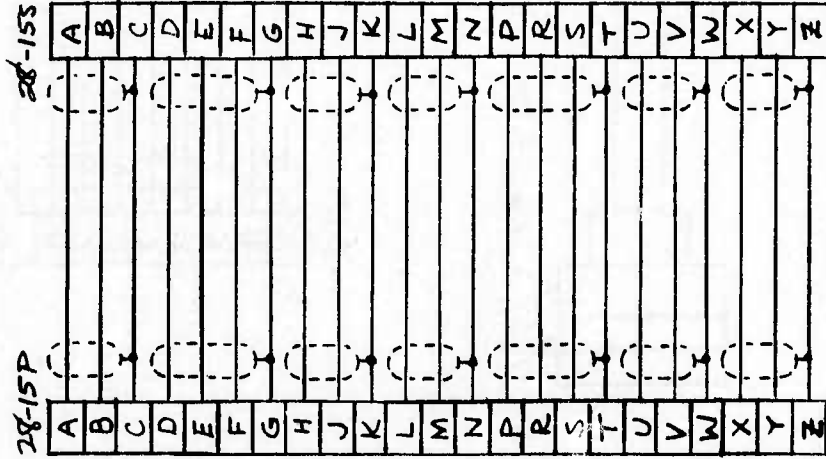
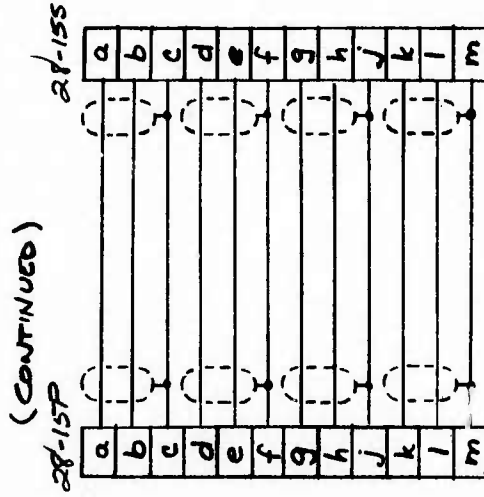
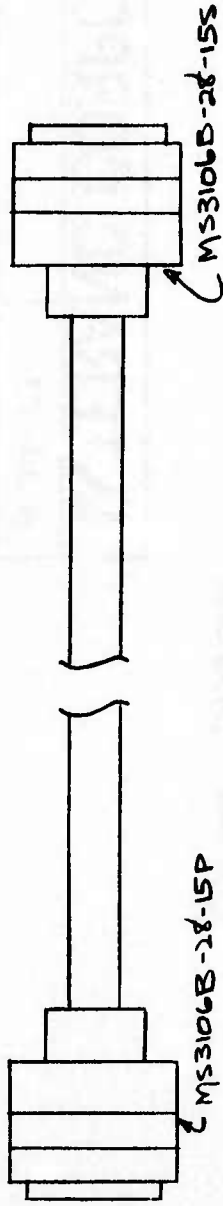

INTERAND CORPORATION

8-28-73

WIRING DIAGRAM FOR 35 CONDUCTOR CABLE

FIGURE A-14

SK-65-04

FIGURE A-14 WIRING DIAGRAM FOR 35 CONDUCTOR CABLE

68

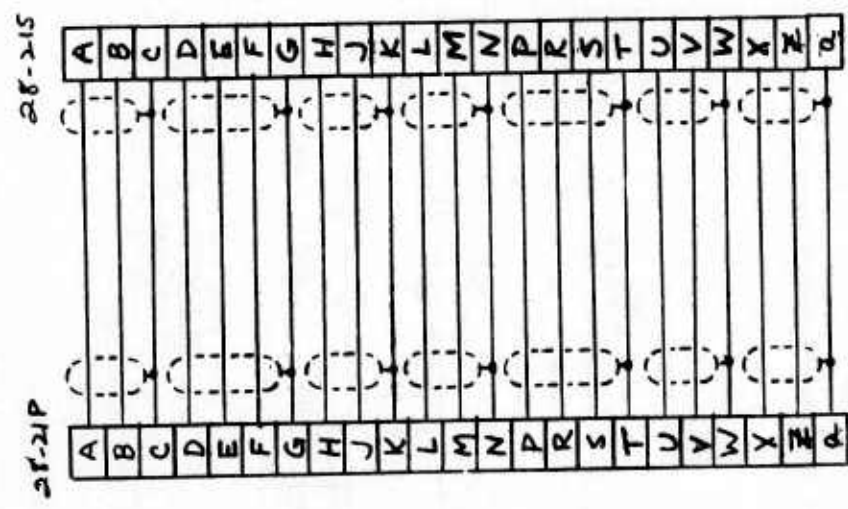
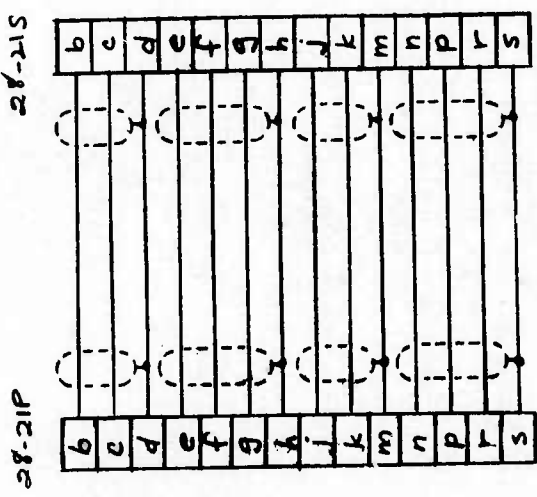
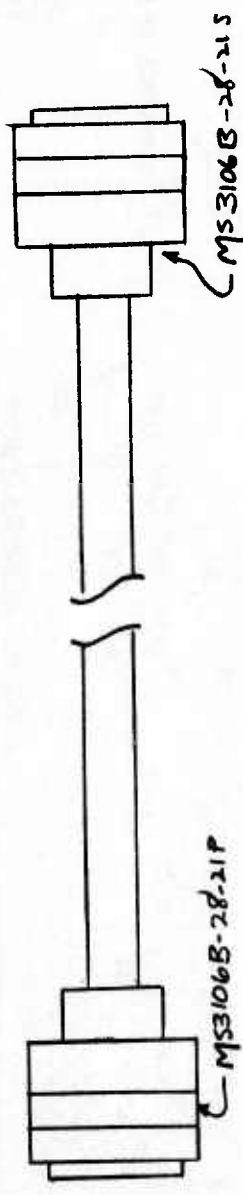

INTERAND CORPORATION

8-28-73	
WIRING DIAGRAM FOR 37 CONDUCTOR CABLE	
FIGURE A-15	SK-GS-05

FIGURE A-15 WIRING DIAGRAM FOR 37 CONDUCTOR CABLE

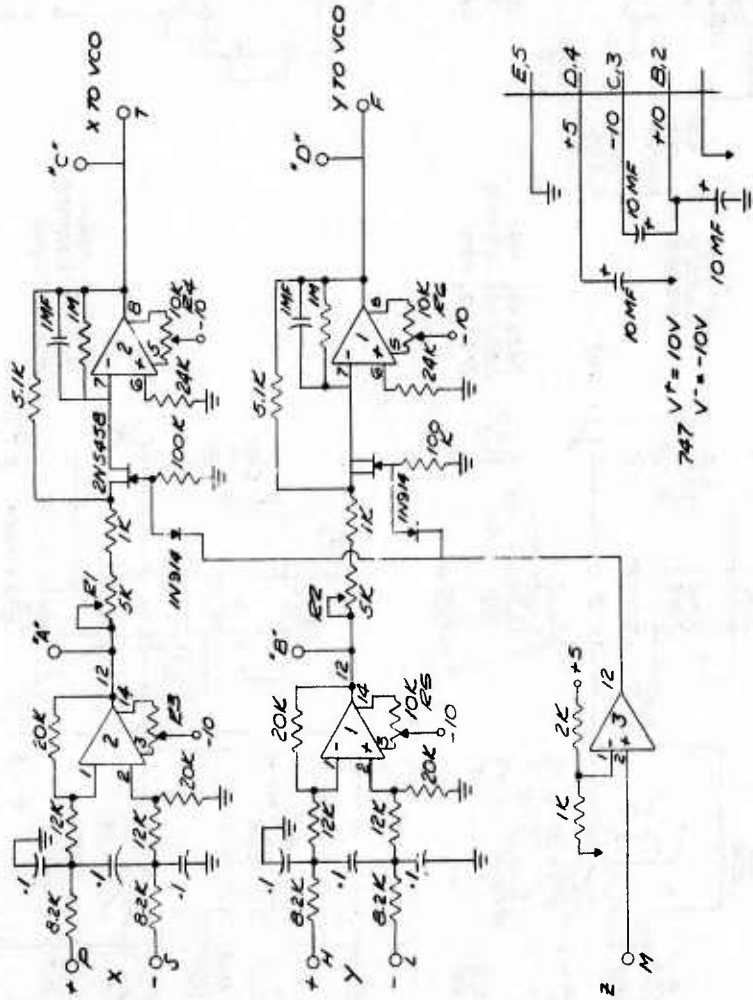

FIGURE A-17
GRAPHICS INPUT SCHEMATIC TRSP
71

INTERAND CORPORATION

SCALE: DRAWN BY: KCB
DATE: 7-25-78 REVISED:

GRAPHICS INPUT SCHEMATIC TRSP
DRAWING NUMBER: C7B12-24

REF 900-501

71

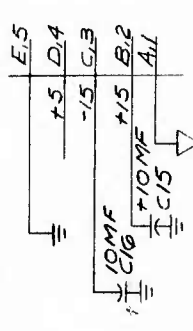
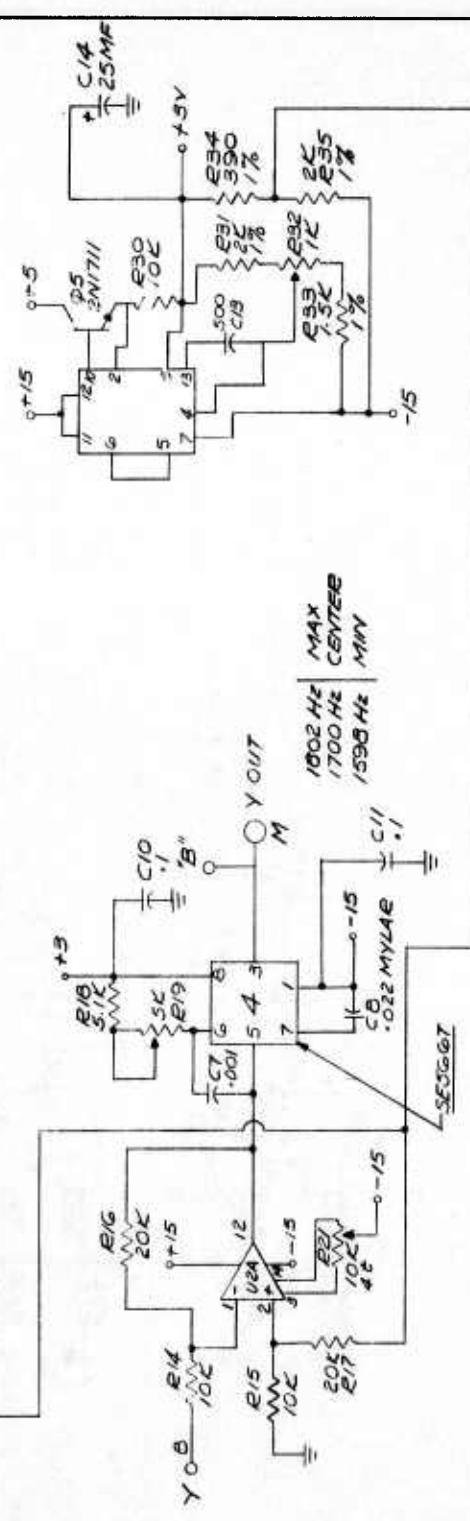
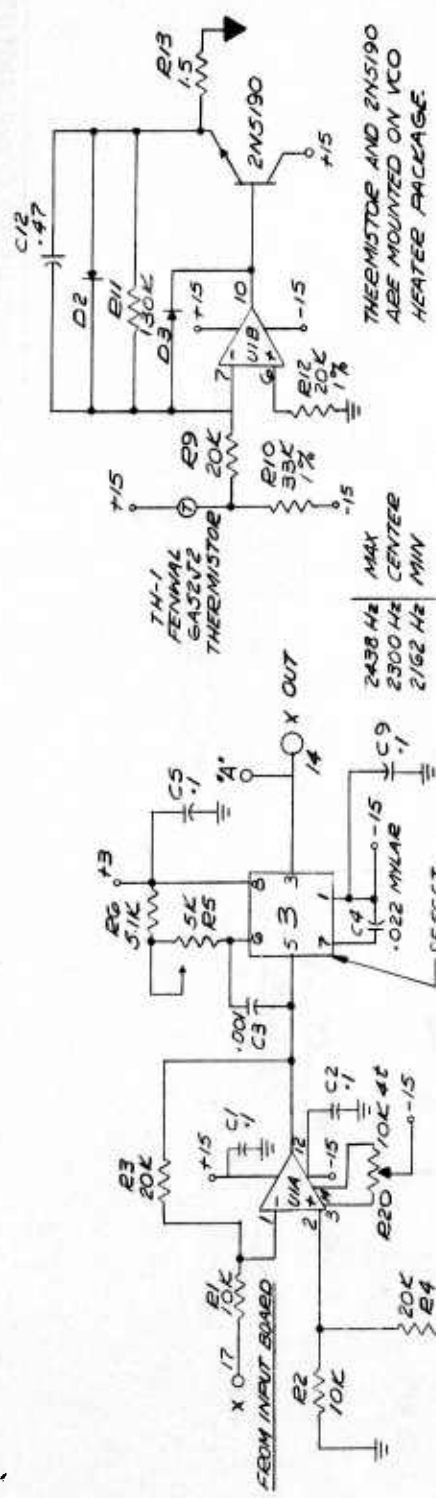

INTERAND CORPORATION

SCALE: 1/25"=1"

DATE: 1-25-78

APPROVED BY: [Signature]

DRAWN BY: [Signature]

VCO SCHEMATIC TASP

FIGURE A-1B

DRAWING NUMBER: K7212-25

FIGURE A-1B
VCO SCHEMATIC TASP
72

INTERNAL COMPANY USE ONLY

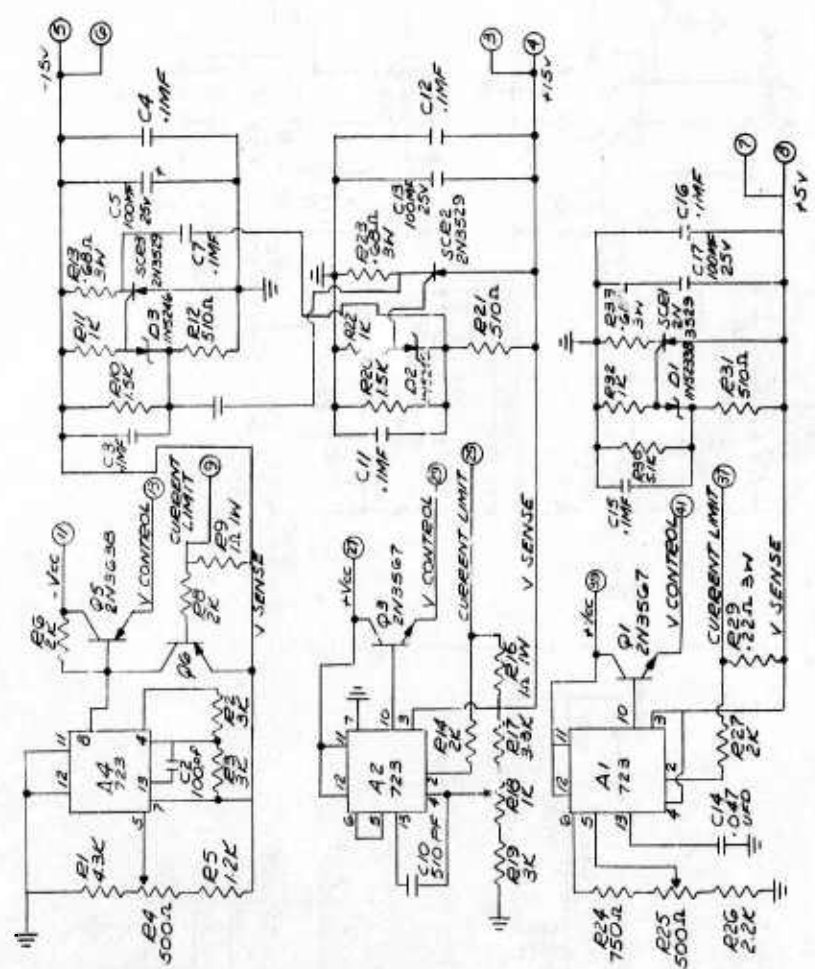
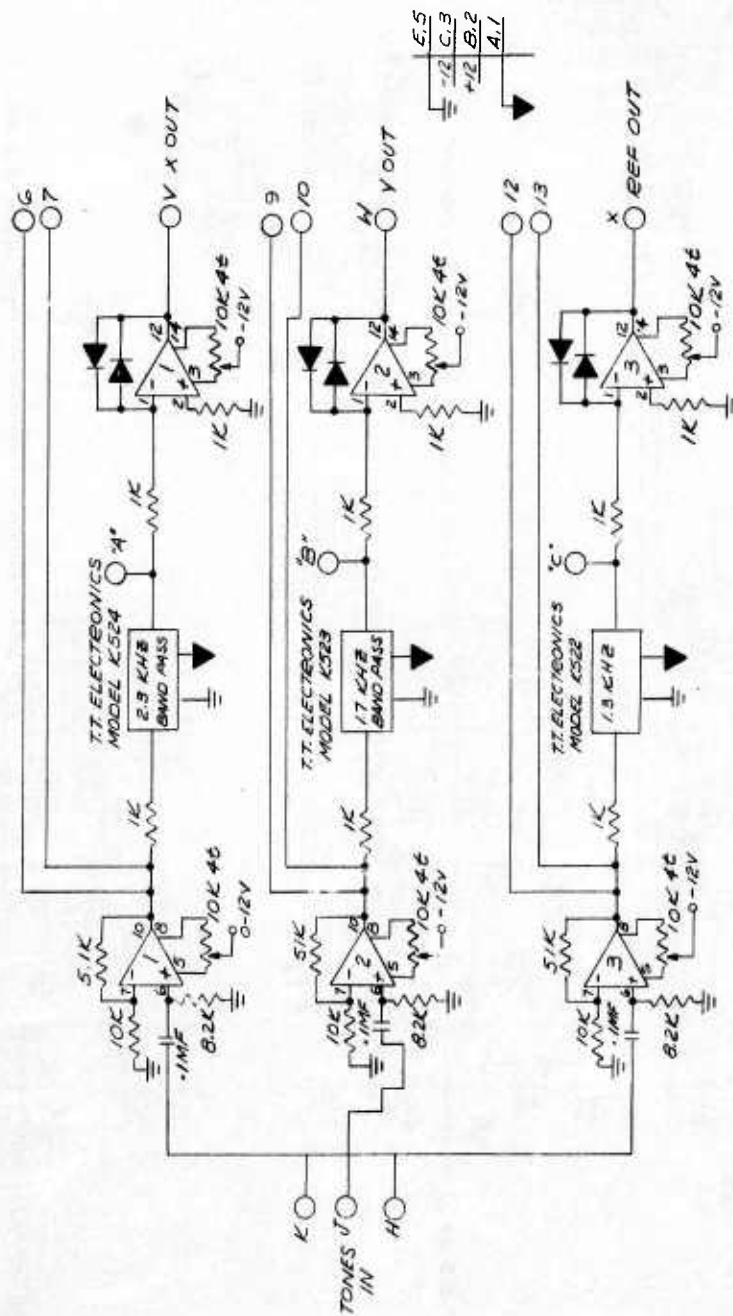

FIGURE A-21
POWER SUPPLY SCHEMATIC TAB.P
75

INTERRAND CORPORATION	
SCALE: _____	APPROVED BY: _____
DATE: 1-25-74	DESIGNED BY: C.B.
POWER SUPPLY SCHEMATIC TAB.P	
FIGURE A-21	DRAWING NUMBER: CTR12-29

REF SK 600-50



INTERAND CORPORATION	
SCALE: 1:25-74	APPROVED BY: [Signature]
DATE: 1-25-74	DRAWN BY: C.L.B.
REVISION:	
FILTER SCHEMATIC TASP	
FIGURE A-23	DRAWING NUMBER: C7812.3/1

FIGURE A-23
FILTER SCHEMATIC TASP
77

REF 900-525

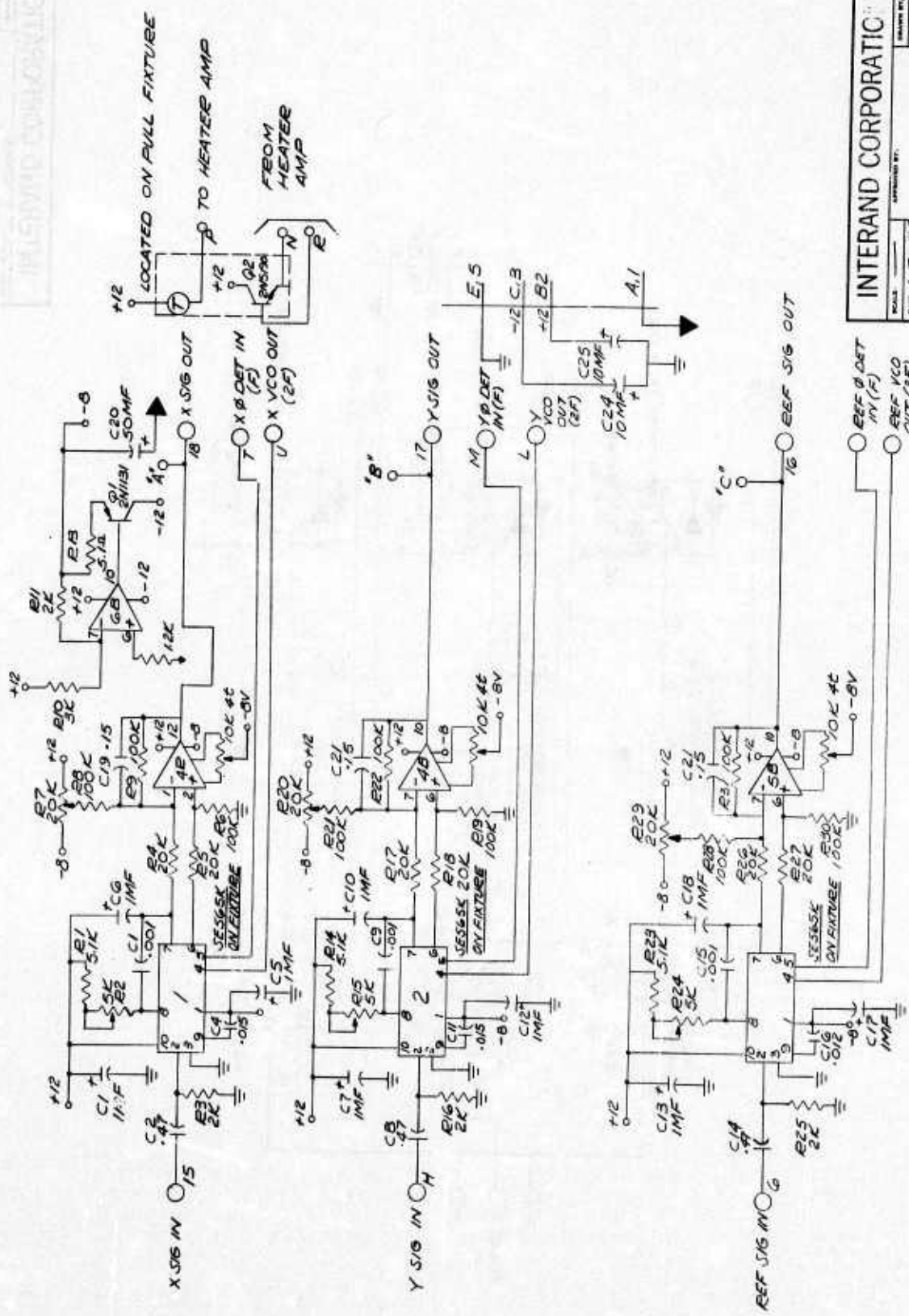

INTERRAND CORPORATION	
SCALE	APPROVED BY:
DATE: 1-25-78	DESIGN: P.C.B.
ALL SCHEMATIC TASP	
FIGURE A-24	REVISION NUMBER
	CT212-33

FIGURE A-20
RLZ SCHEMATIC TASP
78

REF 200-578

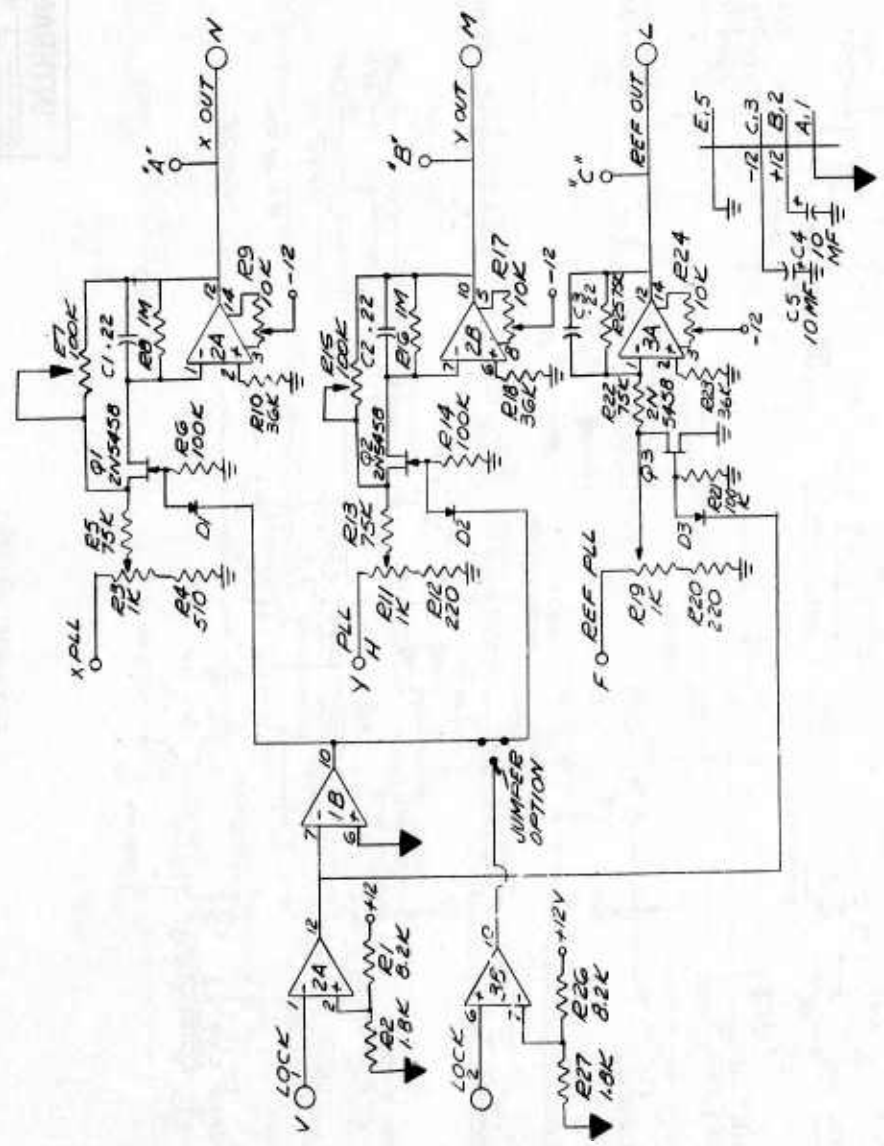
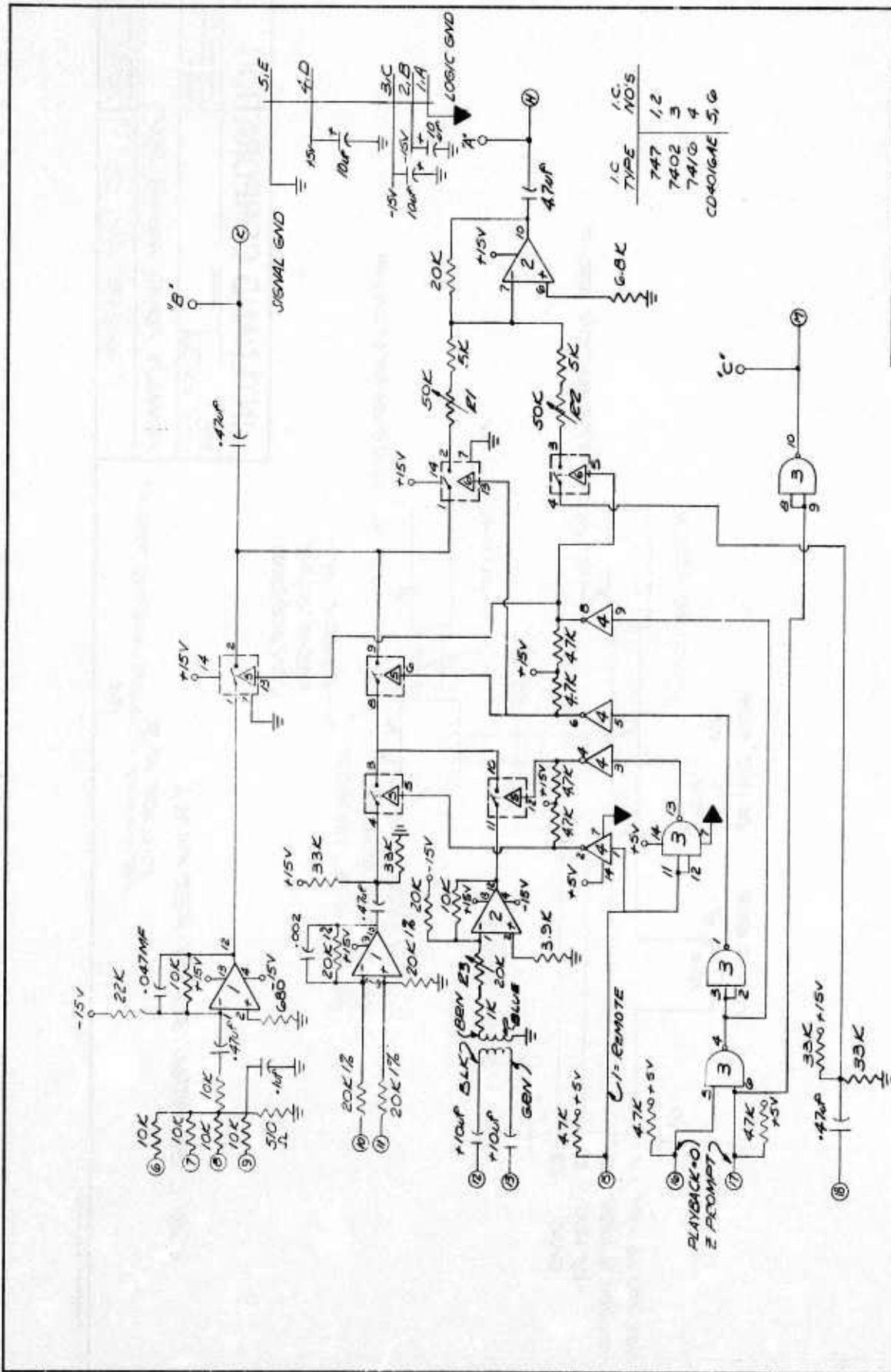

FIGURE A-25
PLL BUFFER SCHEMATIC TASP
79

INTERAND CORPORATION	
SCALE: _____	APPROVED BY: C.B.
DATE: 7-25-74	DRAWN BY: _____
PLL BUFFER SCHEMATIC TASP	
FIGURE A-25	
DRAWING NUMBER: CTR12-32	

REF 200-531

PRINTED ON 60 LB. WEIGHT PAPER



IC TYPE	IC NOS
7407	1, 2
7402	3
7410	4
CD4016A	5, 6

INTERAND CORPORATION	
DATE: 1-25-70	APPROVED BY: [Signature]
RECORD LOGIC SCHEMATIC TRASP	
FIGURE A-29	REVISION NUMBER: CTR12-37

FIGURE A-29
RECORD LOGIC SCHEMATIC TRASP
83

REF: 900-547

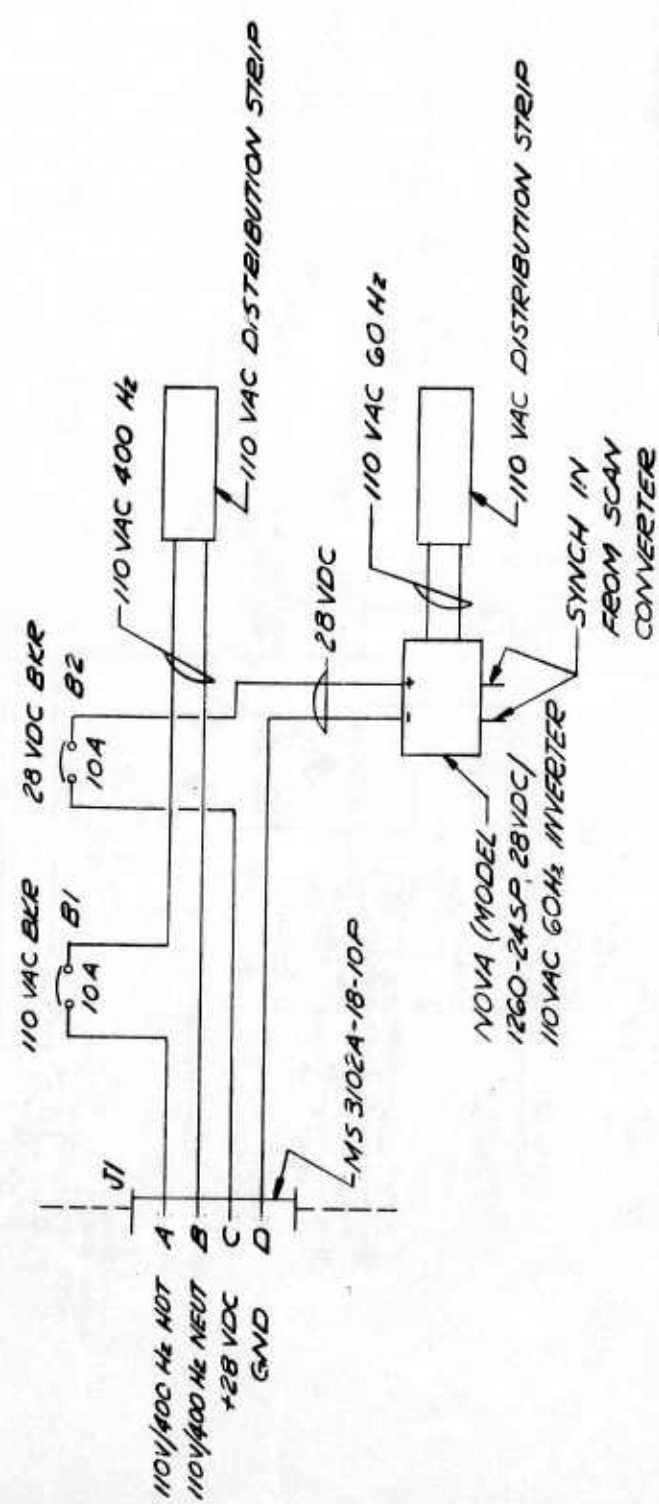

INTERAND CORPORATION	
SCALE: _____	APPROVED BY: CLB
DATE: 1-25-74	REVISED: _____
PRIMARY POWER WIRING, TASP	
FIGURE A-30	DRAWING NUMBER: SK65-13

1. B1 & B2 MOUNTED ON FET PANEL.
FIGURE A-30
PRIMARY POWER WIRING TASP
89

37 PIN CONNECTOR TASP PKG - J2

PIN	FUNCTION	DESTINATION
D	PLAYBACK COMMAND	PIN 3, VI RR P. 16 RL CARD
F	GND	PIN 2, VI RR P. 5 RL CARD
L	TAPE STOP LAMP DR.	PIN 4, SPOTMASTER REMOTE
M	TAPE STOP LAMP RET.	PIN 5
K	TAPE START REMOTE	PIN 2
H	TAPE START REMOTE	PIN 3

10 PIN CONNECTOR TASP PKG - J4

PIN	FUNCTION	DESTINATION
A	AUDIO IN	PIN 1, VI RR P. 12 RL CARD
B	GND	PIN 5, 37 PIN CONN.
C	AUDIO OUT	PIN 8, VI RR P. 4 RL CARD
D	REMOTE	PIN 9, VI RR P. 15 RL CARD
E	KEY	PIN 15, VI RR P. 20, TO CARD

FIGURE A-31
CONNECTORS J2 & J4
BS

INTERAND CORPORATION

SCALE: _____ DATE: 1-25-74 APPROVED BY: _____ DRAWN BY: LB
REVISED: _____

CONNECTORS J2 & J4

FIGURE A-31
DRAWING NUMBER
SK-65-07