

UNCLASSIFIED

AD NUMBER

ADB002186

LIMITATION CHANGES

TO:

Approved for public release; distribution is unlimited.

FROM:

Distribution authorized to U.S. Gov't. agencies only; Test and Evaluation; FEB 1975. Other requests shall be referred to Air Force Flight Dynamics Laboratory, FEE, Wright-Patterson AFB, OH 45433.

AUTHORITY

affdl ltr, 27 dec 1977

THIS PAGE IS UNCLASSIFIED

THIS REPORT HAS BEEN DELIMITED
AND CLEARED FOR PUBLIC RELEASE
UNDER DOD DIRECTIVE 5200.20 AND
NO RESTRICTIONS ARE IMPOSED UPON
ITS USE AND DISCLOSURE.

DISTRIBUTION STATEMENT A

APPROVED FOR PUBLIC RELEASE;
DISTRIBUTION UNLIMITED.

AFFDL-TR-75-7

AD B 002186

VARIABLE INDUCTIVE REACTANCE
TEMPERATURE CONTROLLER

M. Owen Bennett
Cryogenic Technology Division
Kinergetics Incorporated

TECHNICAL REPORT AFFDL-TR-75-7

February 1975



Distribution limited to U. S. Government Agencies only; test and evaluation; (February 1975). Other requests for this document must be referred to AF Flight Dynamics Laboratory (FEE), Wright-Patterson AFB, Ohio 45433.

Air Force Flight Dynamics Laboratory
Air Force Systems Command
Wright-Patterson Air Force Base, Ohio

NOTICE

When Government drawings, specifications, or other data are used for any purpose other than in connection with a definitely related Government procurement operation, the United States Government thereby incurs no responsibility nor any obligation whatsoever; the fact that the Government may have formulated, furnished, or in any way supplied the said drawings, specifications, or other data is not to be regarded by implication or otherwise as in any manner licensing the holder or any other person or corporation, or conveying any rights or permission to manufacture, use, or sell any patented invention that may in any way be related thereto.

This document pertains to the test and evaluation of hardware offering significant military advantages. In addition to Government recipients, the document is intended to preferentially communicate results to those individuals and organizations outside of the U. S. Government that are actively engaged in the national defense effort. A currently valid DOD security clearance for access to material classified Confidential or higher is more than sufficient evidence of required involvement in defense activities, and this document may be released to individuals and organizations possessing such clearance without the previous approval of AFFDL/FEE. Any others must request release on an individual basis. After a period of four years from the date shown in the distribution statement, it is anticipated that distribution of this document will be unlimited and its public release authorized.

This technical report has been reviewed and is approved for publication.

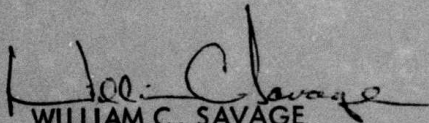
WILLIAM C. SAVAGE
Chief, Environmental Control Branch
Vehicle Equipment Division
Air Force Flight Dynamics Laboratory

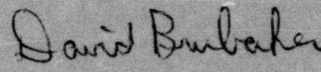
DAVID BRUBAKER
Project Engineer

Copies of this report should not be returned unless return is required by security considerations, contractual obligations, or notice on a specific document.

UNCLASSIFIED

SECURITY CLASSIFICATION OF THIS PAGE (When Data Entered)

REPORT DOCUMENTATION PAGE		READ INSTRUCTIONS BEFORE COMPLETING FORM
1. REPORT NUMBER AFFDL-TR-75-7	2. GOVT ACCESSION NO.	3. RECIPIENT'S CATALOG NUMBER
4. TITLE (and Subtitle) VARIABLE INDUCTIVE REACTANCE TEMPERATURE CONTROLLER		5. TYPE OF REPORT & PERIOD COVERED Final Report covering period of August 1971 thru February 1975
7. AUTHOR(s) M. Owen Bennett		6. PERFORMING ORG. REPORT NUMBER
9. PERFORMING ORGANIZATION NAME AND ADDRESS Kinergetics Incorporated 6029 Reseda Boulevard, Tarzana, CA 91356		8. CONTRACT OR GRANT NUMBER(s) F33615-72-C-1031
11. CONTROLLING OFFICE NAME AND ADDRESS Air Force Flight Dynamics Laboratory Air Force Systems Command Wright-Patterson AFB, Ohio 45433		10. PROGRAM ELEMENT, PROJECT, TASK AREA & WORK UNIT NUMBERS Project 6146, Task 61460310
14. MONITORING AGENCY NAME & ADDRESS (if different from Controlling Office)		12. REPORT DATE February 1975
		13. NUMBER OF PAGES 98
		15. SECURITY CLASS. (of this report) Unclassified
		15a. DECLASSIFICATION/DOWNGRADING SCHEDULE
16. DISTRIBUTION STATEMENT (of this Report) Distribution limited to U. S. Government Agencies only; test and evaluation; (February 1975). Other requests for this document must be referred to AF Flight Dynamics Laboratory (FEE), Wright-Patterson AFB, Ohio 45433.		
17. DISTRIBUTION STATEMENT (of the abstract entered in Block 20, if different from Report)		
18. SUPPLEMENTARY NOTES		
19. KEY WORDS (Continue on reverse side if necessary and identify by block number) Temperature Controller Cryogenic Refrigerator Vuilleumier Refrigerator Inductor		
20. ABSTRACT (Continue on reverse side if necessary and identify by block number) This final report describes the research and development performed on a variable inductive reactance temperature controller. The objective was to develop a device to control the hot end temperature of the hot cylinder of a Vuilleumier cryogenic refrigerator in the range from 1200° F to 1300° F. The concept was proved viable on a component basis; the toluene fluid temperature sensor, bellows motion transmitter, variable air gap control inductor and cylinder brazing processes were proved. However, a complete system was never successfully tested. Techniques for sizing a variable inductive		

DD FORM 1 JAN 73 1473

EDITION OF 1 NOV 65 IS OBSOLETE

UNCLASSIFIED

SECURITY CLASSIFICATION OF THIS PAGE (When Data Entered)

UNCLASSIFIED

SECURITY CLASSIFICATION OF THIS PAGE(When Data Entered)

20) Abstract (continued)

reactance temperature controller are presented so that extrapolations can be made on other applications.

UNCLASSIFIED

SECURITY CLASSIFICATION OF THIS PAGE(When Data Entered)

FOREWORD

This report, prepared by personnel of Kinergetics Incorporated, 6029 Reseda Blvd., Tarzana, California is on the exploratory development program to develop a Variable Inductive Reactance Temperature Controller. It covers work performed between August 1971 and January 1975. The work was done at Kinergetics Incorporated, under Project 6146, Task 6146 0310, contract F33615-72-C-1031 through sponsorship extended by the Air Force Flight Dynamics Laboratory. The project monitor was David Brubaker (AFFDL/FEE). Mr. M. Owen Bennett, Director, Cryogenics Technology Division, Kinergetics Incorporated was the Program Manager. This report was submitted by the author in February 1975.

TABLE OF CONTENTS

	<u>Page</u>
I. INTRODUCTION AND SUMMARY	1
II. DESIGN PHILOSOPHY	3
1. Objectives	3
2. Basic Description	3
III. EARLY PARAMETRIC STUDIES	7
1. Damping	7
2. Fluid Selection	8
3. Mechanism Mass Minimization	8
4. Dead Volume Minimization	10
5. Pressure Selection	10
6. Ambient Temperature Compensation	10
7. Activating Volume Design	13
8. Manual Adjustment Design	13
IV. EARLY EMPERICAL STUDIES	15
1. Government Furnished Vuilleumier Refrigerator Tests	15
2. Tests With Variable Inductances	15
3. Inductor Construction Technique	23
V. SYSTEM CONFIGURATION	25
1. Bellows and Plunger	25
2. Inductor	27

TABLE OF CONTENTS (continued)

	<u>Page</u>
3. Hot Cylinder Assembly	27
4. Safety Switch Assembly	33
vi. DEVELOPMENT OF THE INDUCTOR ASSEMBLY	39
vii. DEVELOPMENT OF THE BELLOWS ASSEMBLY	47
viii. DEVELOPMENT OF THE HOT CYLINDER ASSEMBLY	53
ix. DESIGN OF VARIABLE INDUCTORS FOR USE IN TEMPERATURE CONTROLLERS	59
x. EXTRAPOLATIONS TO OTHER APPLICATIONS	65
xi. CONCLUSIONS AND RECOMMENDATIONS	67
 APPENDIXES	
I. STATEMENT OF WORK	69
II. AMBIENT TEMPERATURE COMPENSATING BELLOWS DESIGN EQUATIONS	73
III. TOLUENE SENSING CIRCUIT CHARGING PROCEDURE	79
IV. LINEAR POWER INDUCTOR DESIGN EQUATIONS	83
V. DESIGN OF AN ELECTRONIC TEMPERATURE CONTROLLER	85

LIST OF ILLUSTRATIONS

<u>Figure</u>		<u>Page</u>
1	Temperature Controller Block Diagram	4
2	Temperature Controller System Schematic	5
3	Simplified Schematic of a Gas Bulb/Bellows System	11
4	Simplified Schematic of a Compensated Gas Bulb/Bellows System	12
5	Refrigerator Test Results	17
6	A Possible Control Inductor Configuration	18
7	Dimensions of a Modified Transformer for Use as a Control Inductor	19
8	Current vs. Voltage Data for a 50 Turn and a 100 Turn Inductor	22
9	Design Layout of Bellows and Plunger	26
10	Design Layout of Inductor Assembly	29
11	Simplified Schematic of Inductor Assembly	31
12	Design Layout of Hot Cylinder Assembly	32
13	Design Layout of Safety Switch Assembly	35
14	Schematic of Control Inductor Test Setup	40
15	Schematic of Flexure Joint/Inductor Assembly	43
16	Design Layout of Modified Bellows Assembly	49
17	Design Layout of Further Modified Bellows Assembly	51
18	Failed Hot Cylinder Assembly	55
19	Successfully Brazed Hot Cylinder Assembly	57
20	Circuit Schematic of Controller Circuit Model	60

LIST OF ILLUSTRATIONS (continued)

<u>Figure</u>		<u>Page</u>
21	Schematic Diagram of Single Bellows Temperature Regulator	74
22	Schematic Diagram of Compensated Bellows Temperature Regulator	75
23	Pneumatic Schematic of Toluene Charging Setup	80
24	Electrical Schematic of Toluene Charging Setup	81
25	Block Diagram of Controller	86
26	Schematic of Hysteresis Type Comparator	87
27	Schematic of Ramp Generator and Series Switch	88
28	Schematic of Voltage Regulator	89

LIST OF TABLES

<u>Table</u>		<u>Page</u>
1	Candidate Fluids and Their Characteristics	9
2	Refrigerator Test Results	16
3	Current vs. Voltage Data for a 50 Turn Inductor	20
4	Current vs. Voltage Data for a 100 Turn Inductor	21
5	Current vs. Voltage Data for Modified Core Inductor	24
6	Current vs. Voltage Data for Control Inductor With Zero Air Gap	41
7	Current vs. Air Gap Length Data for Control Inductor	42
8	Control Inductor Current vs. Fluid Circuit Pressure Data	45
9	Control Inductor Air Gap Length vs. Fluid Circuit Pressure Data	48

SECTION I

INTRODUCTION AND SUMMARY

A significant problem associated with Vuilleumier refrigerators is temperature control at the hot end of the hot cylinder. For reasons of machine efficiency and cylinder stress capability, the hot end temperature must be regulated within about $\pm 50^\circ$ F of the nominal design point. In the past, electronic control systems have been developed to perform the temperature control of the hot cylinder through the use of various types of sensors. However, the high electrical energies and rapid switching rates of certain types of these devices can introduce electromagnetic interference into the infrared detector. For this reason, it is advantageous to examine the feasibility of alternative hot end temperature control systems. One such candidate system is a variable inductive reactance device controlled mechanically by a fluid bulb thermal sensor located on the hot cylinder of the Vuilleumier refrigerator.

The purpose of this program was to design, develop and demonstrate the feasibility of the variable inductive reactance temperature controller and to extrapolate its use to various refrigerator sizes and operating conditions. Results of the program indicate that such a concept is indeed feasible, even though a complete system was not assembled and tested in its final configuration. Due to difficulties encountered during the development phase, this program was not pursued to completion.

This report is a description of the design, fabrication, development and testing which was accomplished and a prediction of controller requirements for a family of Vuilleumier refrigerators. The detailed design of the temperature controller components is contained in a separate Engineering drawing package. The temperature controller components have been delivered to the United States Air Force, Flight Dynamics Laboratory, at the Wright-Patterson Air Force Base.

A summary of the system performance parameters is listed as follows:

System input	110 to 118 volts, 400 Hz, one phase
Heater input power range	90 to 160 watts
Refrigerator operating conditions:	
Motor speed	0 to 10 rps
Ambient temperature	0 to 120° F
Cooling load	0 to 2 watts
Hot end temperature range	1200 to 1300° F

SECTION II

DESIGN PHILOSOPHY

1. OBJECTIVES

The program objective was to develop a practical and reliable inductive reactance temperature controller and to demonstrate the feasibility of its application to Vuilleumier refrigerators.

In addition to performing the basic thermal control function, the controller was required to be:

- 1) of simple construction;
- 2) small (volume less than 8 in³);
- 3) lightweight (weigh less than 2 lb);
- 4) reliable.

The use of a variable inductive reactance for heater input power modulation and a fluid temperature sensor system was specified in the contractual Statement of Work (contained herein as Appendix I). The system was also required to have a redundant safety switch. For demonstration purposes, the actual controller was to be adapted and retrofitted into a Hughes Aircraft Company 77° K Vuilleumier refrigerator (P/N X447525-100).

In its design function, Kinergetics Incorporated was to:

- 1) select the inductor configuration;
- 2) select the sensor fluid type and operating pressure,
- 3) design the inductor actuating mechanism;
- 4) design a safety switch mechanism;
- 5) integrate the above components into a system with the hot cylinder of an operating refrigerator.

2. BASIC DESCRIPTION

Basic controller system design is presented in the block diagram and system schematic of Figures 1 and 2. As shown, an inductor is placed in series with the hot cylinder heater. The voltage drop across the hot cylinder heater is regulated by varying the AC voltage drop across the inductor. The AC voltage drop is varied by modulating the length of an air gap which makes the inductance of the inductor variable.

The temperature at the hot end of the hot cylinder is sensed by a fluid filled sensor bulb. The fluid pressure developed in the bulb then acts to vary the force transmitted by a bellows. The force developed in the bellows acts through a transfer mechanism to modulate the air gap length in the inductor.

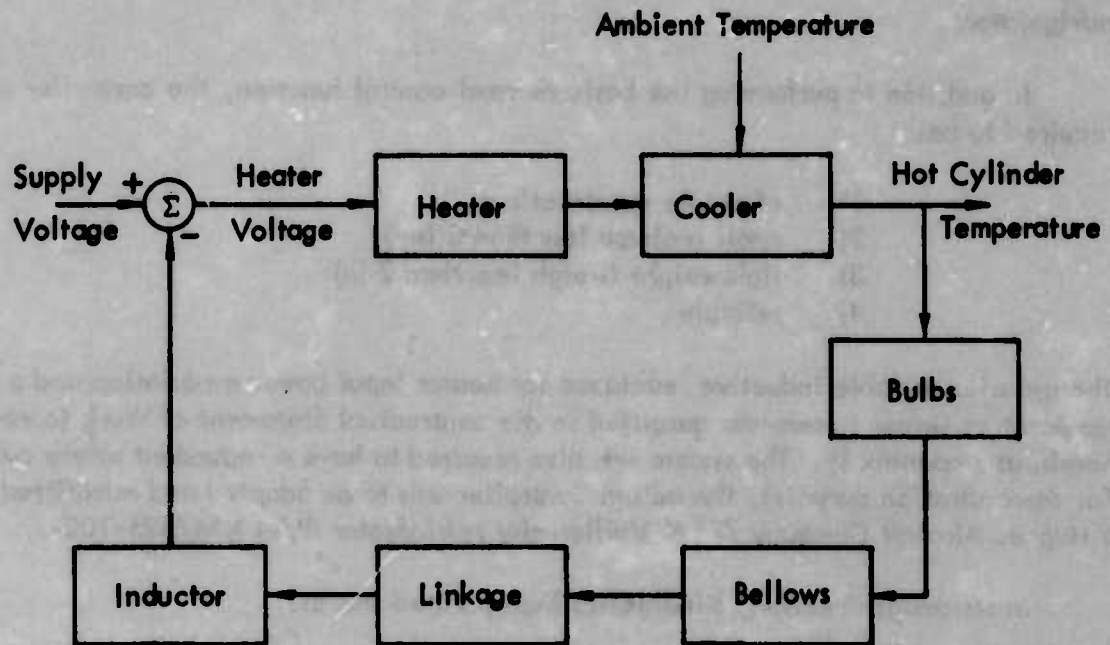

Figure 1 - Temperature Controller Block Diagram

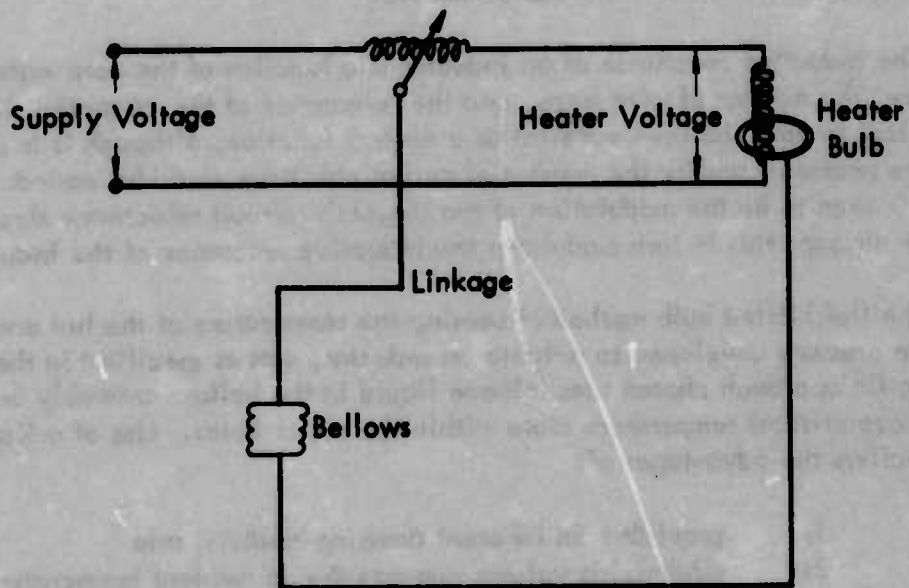

Figure 2 - Temperature Controller System Schematic

Upon initial operation of the system, the pressure in the fluid sensor circuit is low and the air gap length is at its maximum. This puts the inductor reactance at its minimum and allows maximum current flow through the heater resistance. As the hot end approaches its normal operating temperature, the sensor circuit fluid pressure increases. The pressure increase exerts force on the mechanism to decrease the inductor air gap length, increase the reactance, and decrease the heater current.

The hot end temperature is, of course, a function of the output of the heater and is proportional to the heater voltage and to the heat removed from the hot cylinder by the refrigerator operation. The heat removed is dependent on the ambient temperature of the refrigerator and on possible deviations from normal operation of several internal refrigerator parameters (i.e., motor speed, gas pressure, regenerator contamination, rider wear, etc.). The required voltage drop across the inductor with all of the above conditions remaining constant is also a function of the system input voltage which can vary from 110 volts to 118 volts AC at 400 Hz.

The inductive reactance of an inductor is a function of the core material and geometry, the number of wire turns, and the reluctance of the magnetic circuit. It is impractical to vary the core material as a control function, although it is conceivable that core geometry and/or the number of active coil turns could be varied. The simplest method is seen to be the modulation of the magnetic circuit reluctance through a variable air gap; this in turn modulates the inductive reactance of the inductor.

The fluid filled bulb method of sensing the temperature of the hot end, and thus using the pressure developed to actuate an inductor, was as specified in the contract. The specific approach chosen uses toluene liquid in the bellows assembly and toluene at its above critical temperature state within the sensor bulbs. Use of a liquid in the bellows offers the advantages of:

- 1) providing an inherent damping medium, and
- 2) minimizing volume changes due to ambient temperature effects.

Toluene was chosen as the working fluid since it has a critical temperature of 320° C, which is well below the cooler operating temperature of 650° C, thus insuring that no phase changes in the fluid would occur at the hot end of the machine. The toluene remains liquid at the ambient bellows temperature extremes for any reasonable pressure and is a simple compound minimizing the molecular changes which could occur at high temperatures in other more complex compounds.

The hot cylinder assembly design incorporated several new approaches to heater and sensor attachments and ambient cooling methods. To create a large thermal capacitance, and thereby minimize transients in the bulb pressure, the heater and bulbs were cast in a large copper block at the top of the cylinder. It was also decided to use the same procedure to integrally cast the ambient air cooling fins to the cylinder base, rather than utilize the separate fin structure which was supplied with the government furnished refrigerator.

SECTION III

EARLY PARAMETRIC STUDIES

A study of the system in basic terms indicates that several factors are closely inter-related. Thus, any parametric selection criteria must be based on an overall system study rather than an investigation of individual parameters. The inter-related parameters which have been chosen for the system design study are listed as follows:

- 1) Damping of the mechanism;
- 2) Fluid selection;
- 3) Mechanism mass minimization;
- 4) Dead volume minimization;
- 5) Pressure selection;
- 6) Ambient temperature compensation;
- 7) Actuating volume design;
- 8) Manual adjustment design.

1. DAMPING

The choice of damping parameters could only be made after a knowledge of the reactance had been obtained. Since this knowledge was directly dependent on the initial test results, it was necessary to express the damping relationship in parametric terms that could be applied after the quantitative relations became known.

The damping problem was studied from two viewpoints:

- 1) damping of the mechanism to protect it from externally induced vibration, and
- 2) damping of the vibration induced by the 400 Hz power form.

The first problem was thought to be best met by a dashpot or other positive device. In the original proposal, a separate dashpot filled with silicone oil was proposed. However, it was decided that the most appropriate fluid to use in the controller is a liquid at ambient temperature rather than a gas. Thus, it became possible to also use basic control as the dashpot. The fluid in the bellows communicates with the sensor line through a small orifice. Since, by design, the fluid was to be at high pressure under all conditions of use, there was no problem with cavitation. Therefore, essentially any degree of fundamental damping could be provided. The vibration induced by the basic power in the inductor could best be combatted with liberal application of a high hysteresis rubber (e.g. RTV), which could also be used at each pin joint. Although the entire mechanical system was preloaded against the magnetic force of the inductance, the fact that the force pulsates at 800 Hz means that a high degree of vibration was present. Each pin joint was liberally coated with RTV to minimize the effect of this vibration.

2. FLUID SELECTION

Preliminary studies indicated that a noble gas (e.g. Argon) was the best choice for a gas if a gas was chosen. The fact that noble gases do not diffuse through metal lattices meant that storage problems would be minimal. Other fluids that could be used included liquids with a relatively low critical temperature and pressure. These would be in a sub-cooled liquid state in the bellows and in a gaseous state in the sensor. The system would be biased so that the pressure would always be above critical pressure. However, in this case, pressure in the sensor was not easily predictable. Additional work was devoted to this area to see if adequate predictability could be achieved. The use of this type of fluid would eliminate the necessity to incorporate ambient temperature compensation mechanisms and would also greatly simplify the damping of the mechanism. Fluids which were under consideration are listed in Table 1.

Because of the simplifications provided, the prime candidate for the fluid choice was a liquid. The liquid would be maintained at a pressure over its critical value to minimize any phase change effects, such as oscillatory boiling and condensing phenomena. Upon consideration of the advantages of this liquid/super critical approach, it was decided that it was the most promising choice for the following reasons:

- 1) Because the volume of the liquid would change very slowly with temperature, a simple device could be used to compensate for changes in ambient temperature.
- 2) The liquids being complex, relatively heavy molecules, would be easy to seal hermetically.
- 3) The elimination of a counteracting bellows system would allow a simpler and lighter moving device for the mechanism.

The liquid chosen early in the program was toluene (C_7H_8). Toluene is a simple compound with a relatively low critical temperature ($320^\circ C$). A simple compound was considered very desirable since better molecular stability at high temperatures could be expected. Preliminary computations indicated that the system would be most sensitive with a fluid having a low critical temperature.

The predictability of the system using toluene was considered a problem. There is little readily available high temperature thermodynamic data on this material. Accordingly, the mechanism was designed to allow for a rather large range of adjustment.

3. MECHANISM MASS MINIMIZATION

A choice of a liquid as the fluid in the sensor eliminated the necessity for both the counteracting bellows system and the separate dashpot. This choice, thus, greatly minimized the overall moving mass in the system.

FLUID	CRITICAL TEMPERATURE (°C)	CRITICAL PRESSURE (Atm)	CRITICAL DENSITY (gm cm ⁻³)
Butane C ₄ H ₁₀	153	37	.26
Ethyl Alcohol C ₂ H ₅ OH	243	63	.28
Ethyl Ether (C ₂ H ₅) ₂ O	194	36	.26
Toluene C ₇ H ₈	320	42	.29

Table 1 - Candidate Fluids and Their Characteristics

4. DEAD VOLUME MINIMIZATION

The selection of liquid toluene as the fluid in the sensor reduced the demand for a high sensor volume to dead volume ratio. This is normally done to lessen the impact of ambient temperature on the liquid volume. However, an approximate ratio between sensor volume and dead volume of 20:1 was maintained to enhance controller sensitivity.

5. PRESSURE SELECTION

Pressure selection was a relatively complicated problem. If a gas had been chosen, the highest pressure allowable would have been used, limited only by mechanical stress consideration. However, since a hybrid fluid was chosen, a detailed examination of the fluid had to be made in order to predict the pressure which would give the best overall sensitivity. To begin with, the system was designed so that the sensor would be at approximately critical density when the unit was at operating temperature. The pressure in the system at that time would be at approximately 67 atmospheres. This was determined to be less than half the safe operating pressure of the bellows chosen for the application. At this pressure, a force of 80 lb was achievable for basic drive and the force change of about 3 lb would result from the allowable temperature shift of 50° F.

6. AMBIENT TEMPERATURE COMPENSATION

The basic sensor, as suggested in the original proposal, was a gas bulb coupled to a bellows movement to drive a mechanical device, as shown schematically in Figure 3. Operation of this device is quite straightforward. As the temperature of the gas bulb increases, the pressure of the gas in the system also increases, which causes the bellows to move slightly. This movement would operate a compensating temperature regulator.

The simple bellows gas bulb system has one drawback. The amount of gas in the bellows cannot be made small enough with respect to the amount of gas in the bulb. Therefore, the system will be somewhat responsive to the temperature that surrounds the bellows as well as that surrounding the bulb. To compensate for this, an opposing bellows system must be used, as shown in Figure 4. The sizing of the two bellows is chosen so that the change in ambient temperature has a negligible effect over the total loading of the system. The design equations for sizing this double bellows system are included as Appendix II to this report.

The selection of a liquid as the operating fluid made the installation of a compensating bellows unnecessary. This is because there is negligible volume change as a function of ambient temperature of a liquid in the bellows. The total shift of ambient temperature from -65° F to 160° F would represent a volume change of about 10% or less in the fluid relative to the bellows enclosure. Since the bellows contains about .010 cubic inch of fluid, this represents a change of .001 cubic inch or less. With an effective bellows area of .081 square inch, this would result in a linear shift of approximately .012 inch in the controls, changing the temperature set point approximately 28° F.

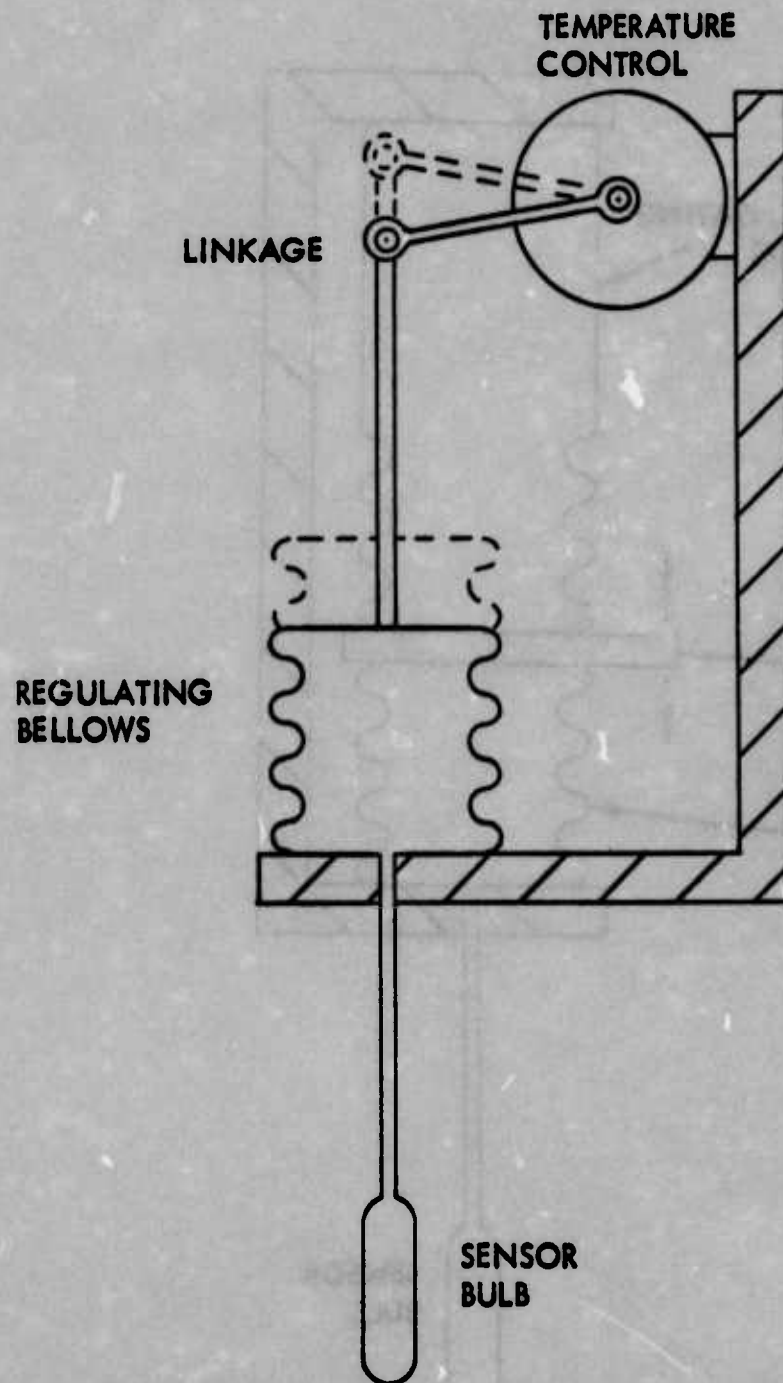

Figure 3 - Simplified Schematic of a Gas Bulb/Bellows System

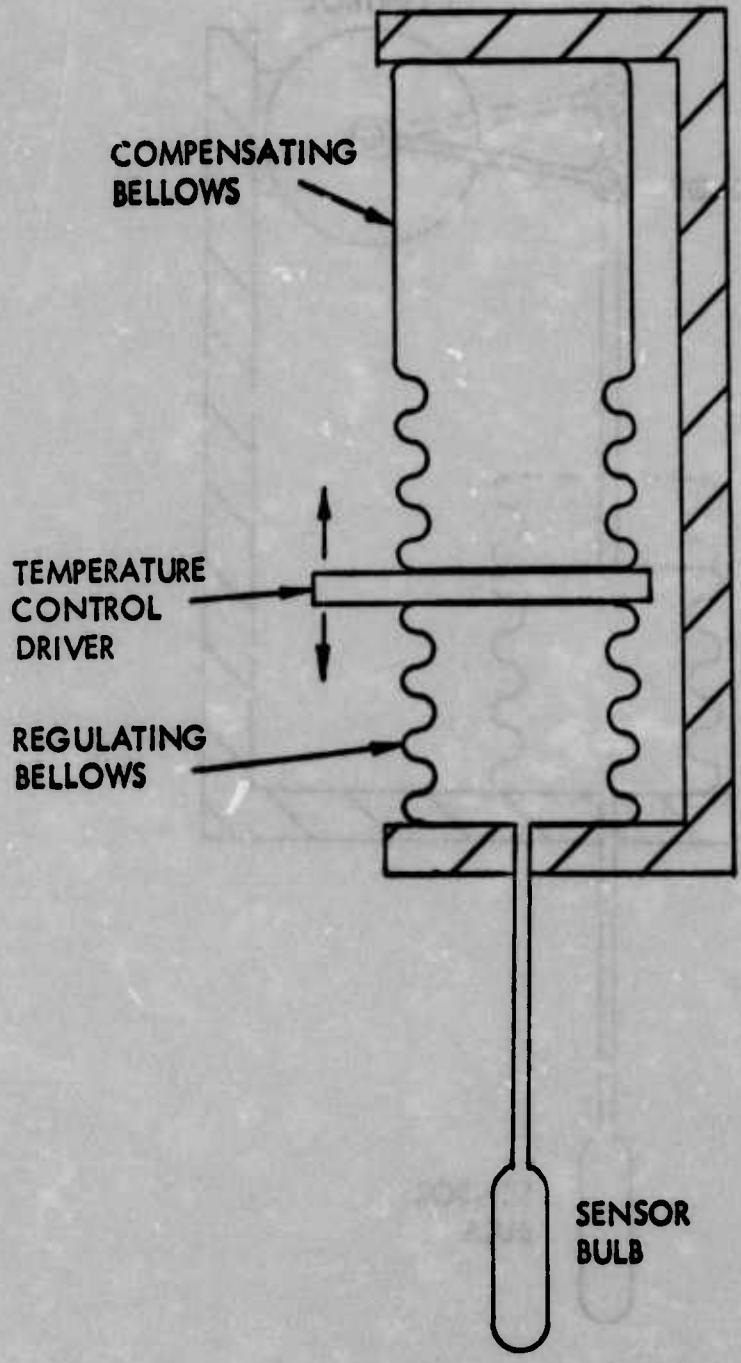

Figure 4 - Simplified Schematic of a Compensated Gas Bulb/Bellows System

7. ACTUATING VOLUME DESIGN

Consideration was given to the choice of either a bellows or a diaphragm. It appeared that neither type of mechanism is inherently superior, as each derives motion from the bending of a thin metal sheet. Thus, the energy per unit volume enclosed is a function of the number of convolutions. Therefore, it was decided to use bellows since they are readily available in nearly any desired size.

8. MANUAL ADJUSTMENT DESIGN

It was decided that the total adjustment mechanism train would be spring loaded so that no random movement would be possible. The adjustment range was designed to be relatively large -- on the order of .200 inch -- to allow for the possible uncertainty of fluid behavior in the sensor bulb.

SECTION IV

EARLY EMPIRICAL STUDIES

During the early portion of the program, several empirical studies were performed on various subcomponents which were anticipated for use in this system. These studies were performed in two areas:

- 1) tests of the repaired government furnished Vuilleumier refrigerator, and
- 2) tests of various inductor configurations.

1. GOVERNMENT FURNISHED VUILLEUMIER REFRIGERATOR TESTS

Upon receipt of the GFE refrigerator, the condition of the equipment was such that it could not be operated due to a damaged hot cylinder. This hot cylinder was subsequently redesigned and refabricated in order to render the refrigerator whole and operable.

The repaired cooler was placed in a test setup such that the ambient temperature around the unit could be varied from 0° to 120° F. The results of this test are given in Table 2 and in Figure 5. The test showed that the power varied only slightly with changes in either ambient temperature or cold cylinder temperature. It appears that the major variable in determining the amount of power which the hot cylinder requires is the rotational speed at which the machine operates. The data substantiates this fact; the power required to operate the machine drops from approximately 160 watts to approximately 92 watts when the drive motor is turned off. It thus appears that the controller must be designed to regulate heater current in the range between 3 and 4.1 amperes.

2. TESTS WITH VARIABLE INDUCTANCES

It was found that conventional audio output transformers in the 5 to 25 watt range have a geometry that is quite suitable for use as a variable inductance in this system. These are composed of laminations in the shapes of "E" and "I". Figure 6 shows how the laminations could be employed in the controller. After some preliminary tests, the transformer was obtained and modified to the dimensions shown in Figure 7. The laminations were modified since the initial tests indicated that the window in the laminations was larger than that needed for use in this system. This is due to the fact that the basic transformer requires at least two windings, each of which carries full power. For the application in this system, only a single winding is required. Thus, for a given allowable resistance in the winding, less space is needed. The modified laminations were wound with 50 turns and 100 turns for the two evaluations of the impedance. The data are shown in Tables 3 and 4 and Figure 8. It appears from these tests that the correct number of turns for this application lies between 50 and 100. Further testing with the actual heater resistance resulted in an initial selection of 75 turns.

Ambient Temp °F	Cold Cylinder Load Watts (IE)	Hot Cylinder Power Watts $\frac{E}{R}$	Temperature Cold °F Hot °F
1. 4	None	156	1252
2. 0	1.03	156	1229
3. -4	2.06	164	1284
4. 37	none	154	1234
5. 37	1.08	162	1265
6. 36	2.08	152	1230
7. 79	none	167	1245
8. 80	1.03	161	1256
9. 81	2.04	161	1258
10. 120	none	164	1222
11. 120	.996	161	1254
12. 120	1.95	164	1267
13. 80	none	91	1239
14. 120	none	93	1282

14 Sept
VM Off
fan on

Table 2 - Refrigerator Test Results

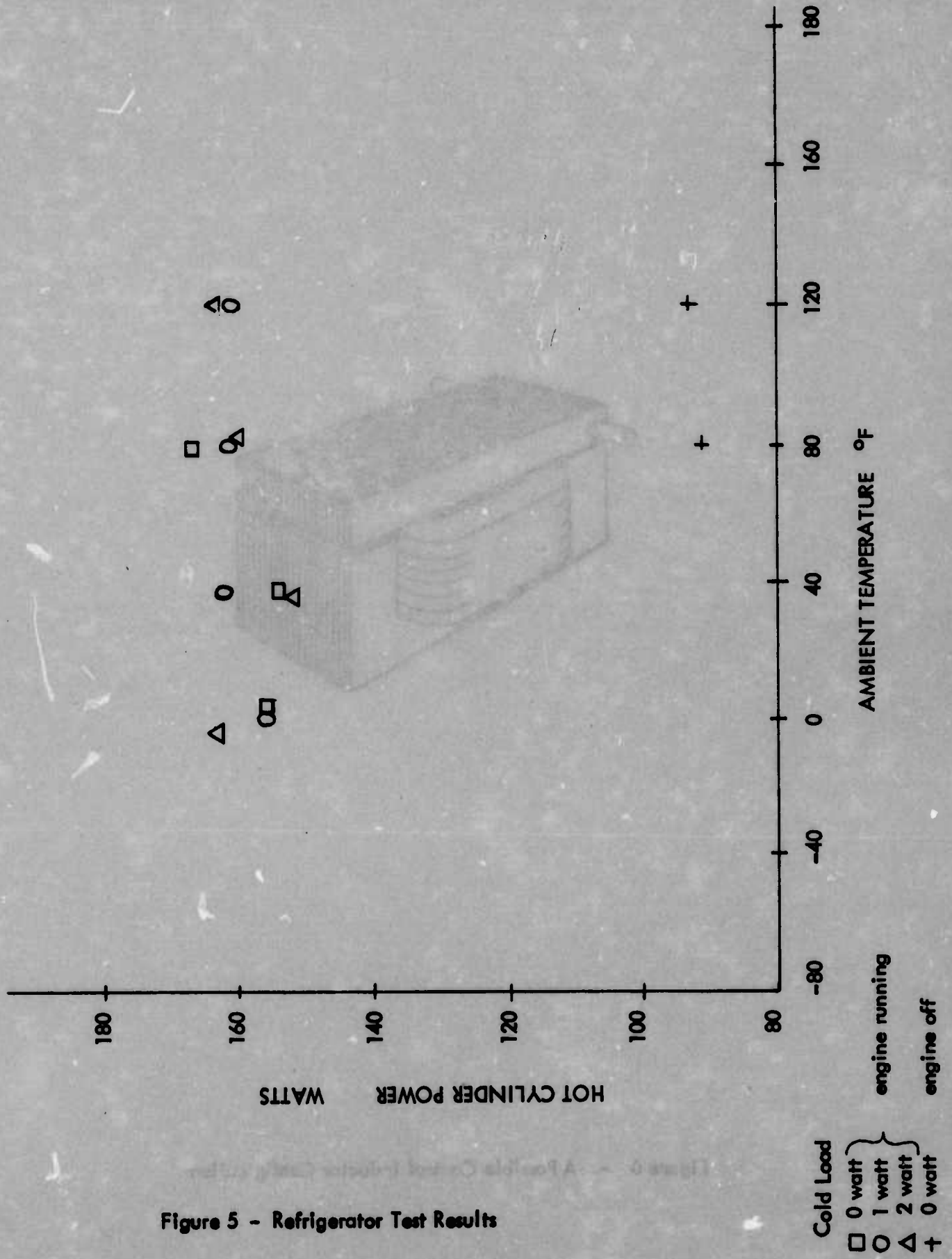

Figure 5 - Refrigerator Test Results

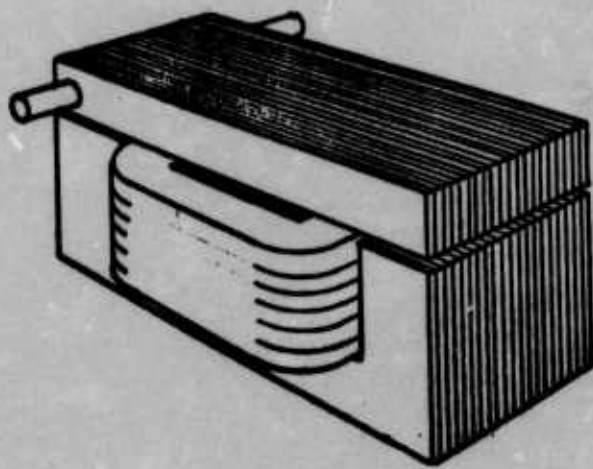

Figure 6 - A Possible Control Inductor Configuration

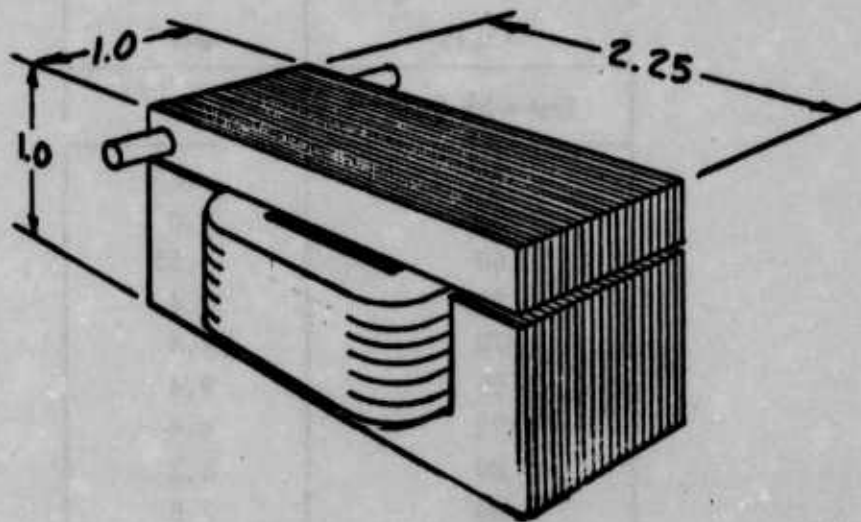

Figure 7 - Dimensions of a Modified Transformer
for Use as a Control Inductor

VOLTS	AMPS
Test with 50 turns	
25	.65
50	1.0
60	1.55
70	3.4
70	2.4
80	9.4
75	4.4
80	8.2
80	7.8
80	7.8
85	10.0
85	10.0

Table 3 - Current vs. Voltage Data for a 50-Turn Inductor

VOLTS	AMPS
Test with 100 turns	
35	.2
50	.28
75	.4
100	.59
125	1.0
125	1.2
140	2.1

Table 4 - Current vs. Voltage Data for a 100-Turn Indicator

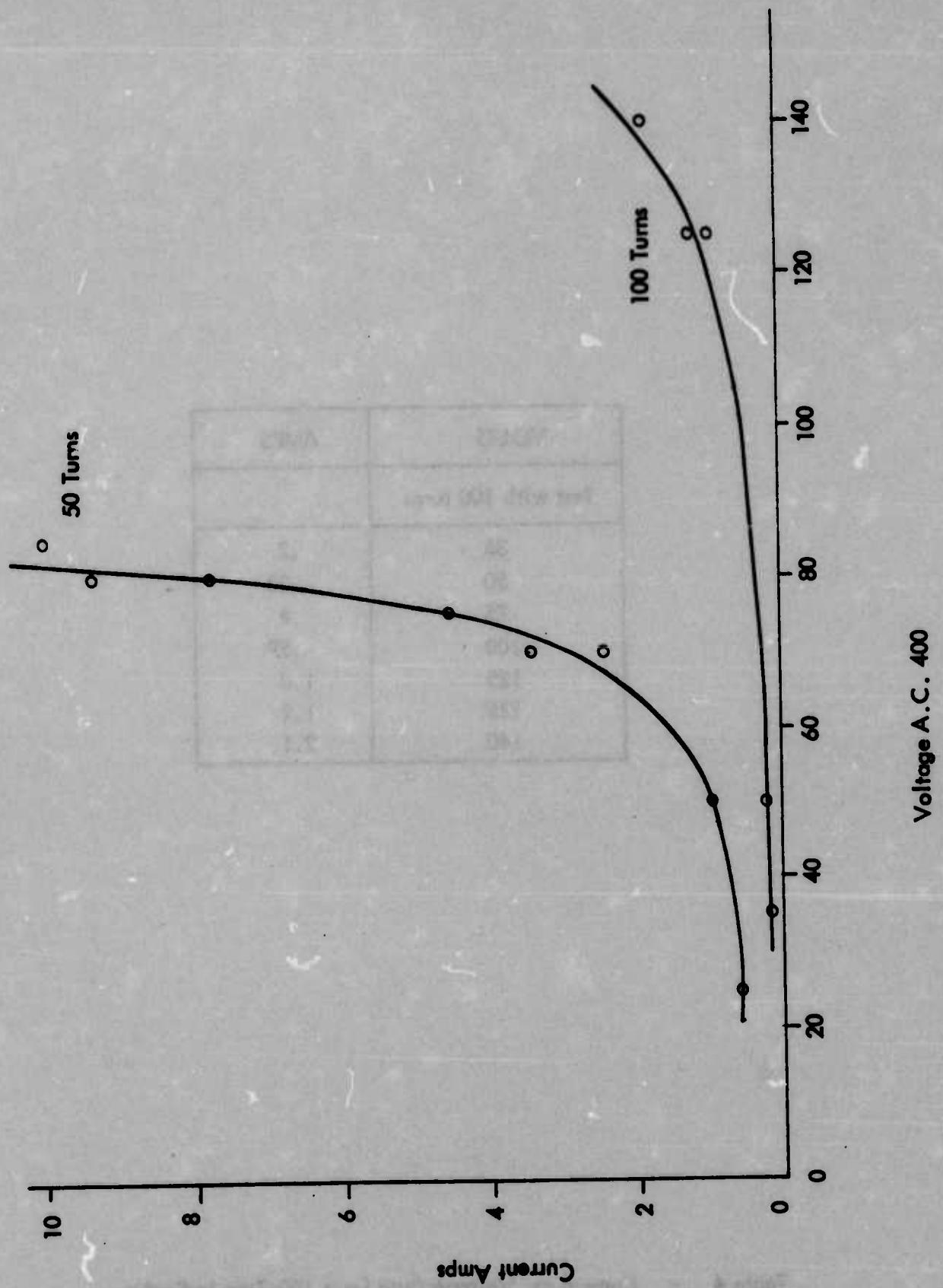

Figure 8 - Current vs. Voltage Data for a 50-Turn and a 100-Turn Inductor

3. INDUCTOR CONSTRUCTION TECHNIQUE

During the early inductor testing, it was found that the inductor verged on instability when it approached its saturation region. Consultation with the inductor manufacturer indicated that this effect was possibly due to the manner in which the core material had been cut in order to alter the size of the final inductor assembly to a more optimum size. The consultation with the manufacturer of the lamination material indicated that a source of the problem could have been stresses induced by the cutting of the core laminations. Any shearing or other machining operations severely stresses magnetic material such that subsequent heat treat processing is required. This heat processing is required in order to restore the magnetic performance at the saturation levels. Subsequent cores were prepared using a different fabrication method.

The technique employed uses an abrasive cutting wheel to cut the laminations. A copious flow of cooling fluid is required during this process to insure that the core material does not reach an excessive temperature. Additionally, after the laminations are cut, a deburring etch solution of H_3PO_4 (50% solution) for 30 minutes at room temperature is recommended. The laminations are then neutralized in tap water and dried. After this process, the core was assembled and tested for sensitivity. The final core dimensions (of the "E" section) are 1.10 inch in width, .85 inch in height, and 2.25 inches in length.

Data from a core which was assembled and tested by this process is presented in Table 5. It was found that cores prepared using this technique were very stable over the linear as well as the saturation range of operation.

UNIT	AMPS
94	1.00
97	1.5
101	2.0
104	2.5
107	3.0
109	3.5
111	4.0
112	4.5
114	5.0
116	5.5
117	6.0
118	6.5
120	7.0
121	7.5
122	8.0
123	8.5
124	9.0
124.5	9.5
125	10.0

Table 5 - Current vs. Voltage Data for Modified Core Inductor

SECTION V

SYSTEM CONFIGURATION

By the time that design studies and empirical studies were completed, the detailed design was finalized. This detailed design is presented herein along with the detailed explanations of the various subassemblies.

1. BELLOWS AND PLUNGER

The bellows and plunger assembly is shown in layout form in Figure 9. As can be seen from the layout, the bellows assembly (Item 3125) connects into the plunger (Item 3122). The plunger then is connected into the inductor assembly (shown in a subsequent figure).

The bellows assembly (Item 3125) consists of a housing, a plunger, and the bellows. Note that the fluid is contained in the annulus between the housing (Item 3107) and the bellows. Note also that the volume within this annulus is very small to maintain the desired 20:1 ratio between the sensor bulb volume and the bellows assembly volume. The connecting rod (Item 3109) is configured such that the bellows cannot be overstretched. This connecting rod bottoms out at the end cap of the bellows assembly. Note further that there is a capillary tube which exits from the housing of the bellows assembly (Item 3107) to facilitate the filling of the assembly with toluene fluid.

The connecting rod of the bellows assembly mates into the plunger at a slip-fit joint. The plunger is configured to slip freely within its assembly by the use of a teflon rider attached at the outside diameter of the plunger. The plunger is biased with a spring so that it tends to be retracted in its rest position. The primary purpose of this spring is to overcome the forces which exist in the inductor, once the inductor is energized with 400 Hz power. The action of the plunger being in its retracted position is to decrease the inductance in the control inductor. This allows the maximum amount of power to be applied to the heater during initial warmup phase. The manual adjustment for setting up the initial gap in the inductor is made by adjusting a nut (Item 3113) at the base of the plunger. The function of this nut is simply to bias the spring into an either more or less contracted position.

In normal operation of this device, as the operating temperature is achieved in the hot cylinder, the pressure within the bellows assembly increases and there is a force transmitted down the connecting rod into the plunger which acts against the spring and tends to close the inductor gap, thereby increasing the inductance of the inductor and decreasing the amount of current which flows into the heater. As the heater begins to cool, the pressure within the bellows assembly is decreased, thereby lessening the force acting against the spring and allowing the inductor gap to open up again. This, in turn, decreases the inductive reactance and allows more current to flow into the heater.

Damping for this mechanism is incorporated in the bellows assembly. The damping is effected by having the fluid flow through the small orifice in the capillary tube.

The bellows assembly is assembled by having the bellows first installed into Item 3119. The next step is to place small split washers (Item 3124) between each of the convolutions over the full length of the bellows. This fills in a good portion of the dead volume in the convolutions of the bellows to enhance the sensor sensitivity.

2. INDUCTOR

The inductor assembly is shown in detail in Figure 10. This particular layout drawing shows the inductor with its "E" lamination section and its "I" lamination section, a lever assembly, and the plunger and spring assembly. This layout is shown in simplified schematic form in Figure 11. In the simplified schematic, again is shown the two portions of the inductor, the lever assembly, and the plunger and spring assembly. As shown in the schematic, the inductor is formed by placing a winding around the center post and one of the outer posts of the "E" section and the "I" section on top. The motion between the plunger and spring is transmitted into the moving "I" lamination section through a lever assembly.

As can be imagined, the electromagnetic forces which exist between the "E" lamination section and the "I" lamination section when the inductor is energized can be very high. The primary purpose for including a lever in this mechanism is to decouple this tremendous amount of force from the plunger, spring and bellows train. In the actual hardware, the distance between pivot number 2 and pivot number 3 is roughly one-sixth of the distance between pivot number 1 and pivot number 3. This decreases the intensity of the forces seen at pivot number 1 by a factor of one-sixth. Note also that capability of moving the pivot point number 2 is included. This was done to allow flexibility in setting up the final mechanism train. Thus, if more motion were found to be necessary out of the bellows plunger portion of the mechanism, the pivot point number 2 could be moved further to the left. This, of course, would only be done if it were found that the bellows plunger train could survive under the intensified forces which would emanate from the air gap in the inductor. Not included in the schematic diagram is the joining structure which exists between the plunger spring housing and the inductor housing. These, of course, are fixed with respect to one another.

3. HOT CYLINDER ASSEMBLY

The hot cylinder, as fabricated, is shown in Figure 12. This assembly consists of the hot cylinder (Item 5), which is fabricated of Inconel, and the heater (Item 8), along with the associated sensor bulbs (Items 7 and 10). This item was designed, fabricated, and assembled to fit the Hughes Aircraft Company Vuilleumier refrigerator, part number X447525-100. The Inconel cylinder was fabricated to non-finished dimensions before its final assembly. When in this unfinished condition, several items were attached to the cylinder, namely a mold form at the base of the cylinder in order to cast the heat sink fins and also a mold at the top of the hot cylinder in order to form the copper block which would act as a thermal capacitance. Prior to the copper brazing or casting

PRECEDING PAGE BLANK-NOT FILLED

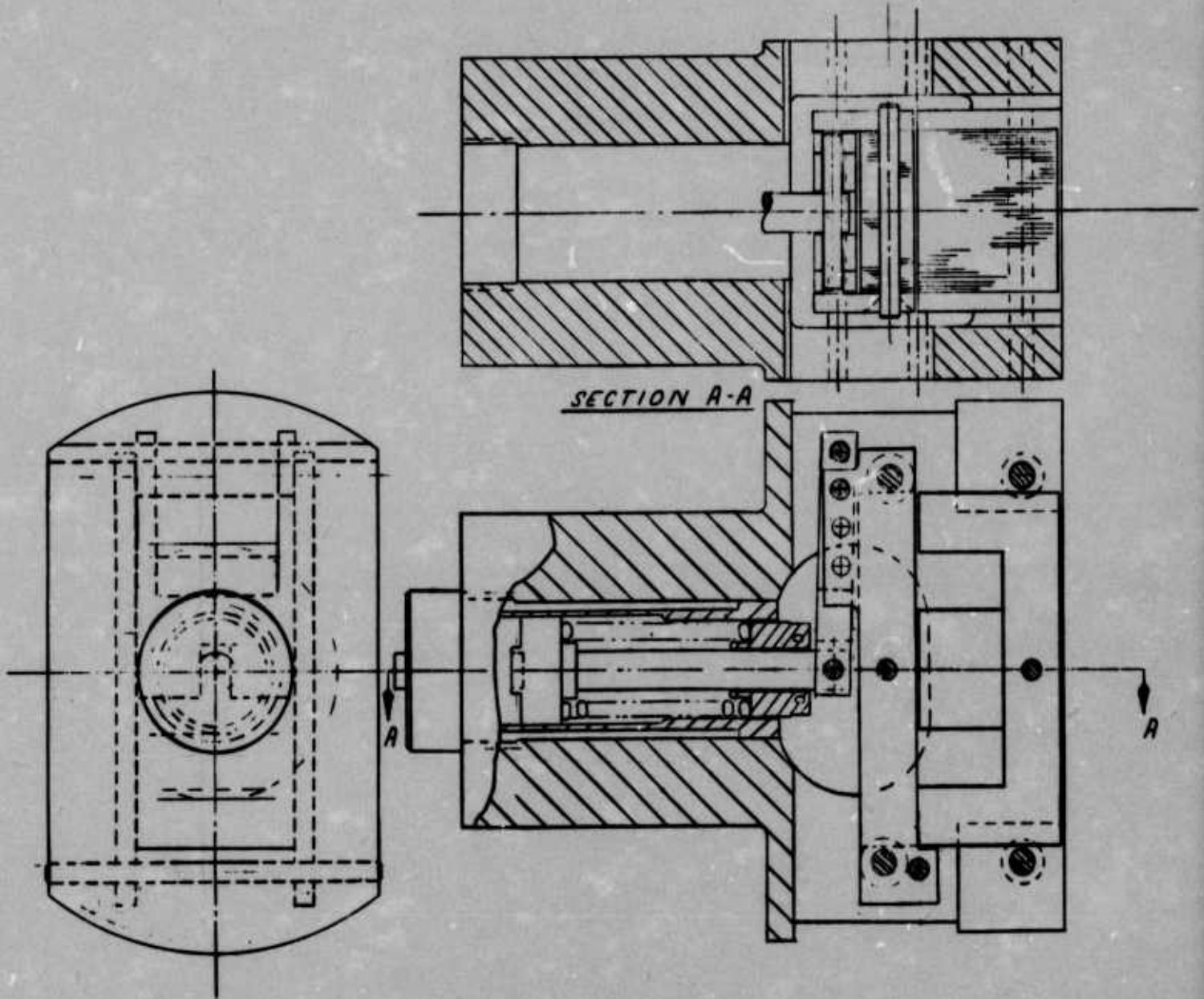

2

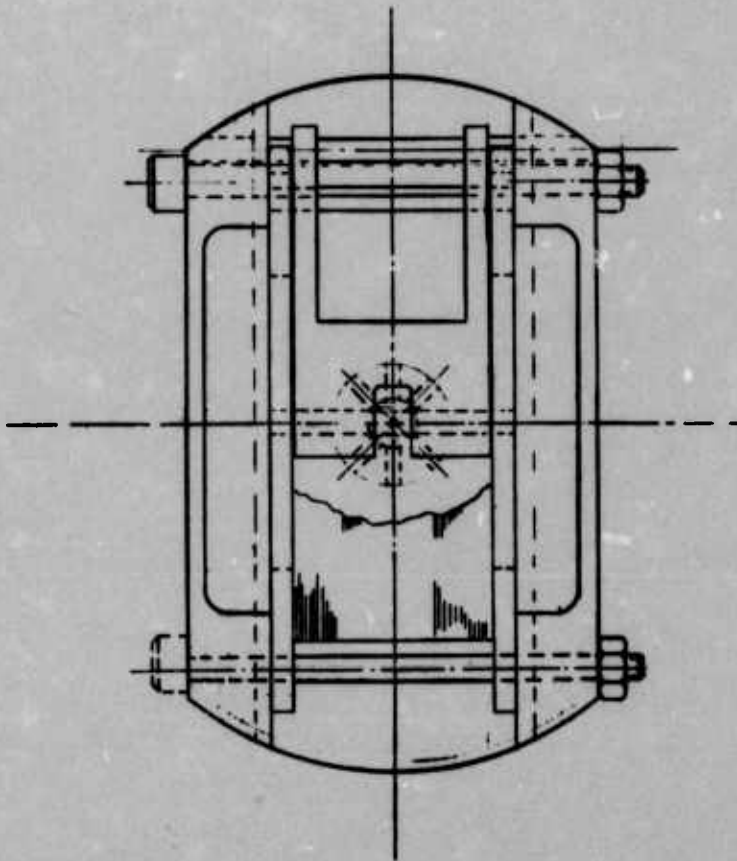

Figure 10 - Design Layout of Inductor Assembly

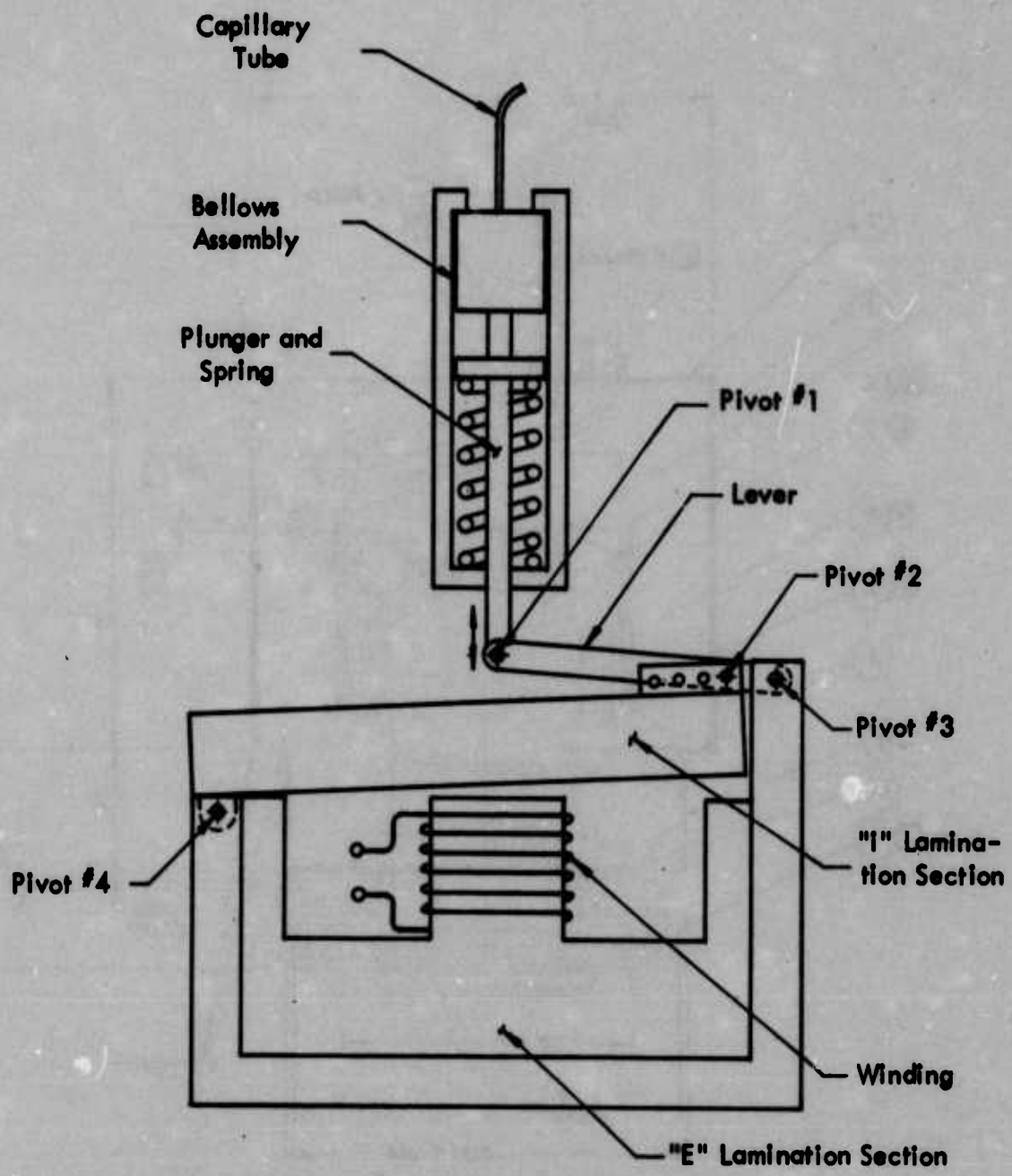
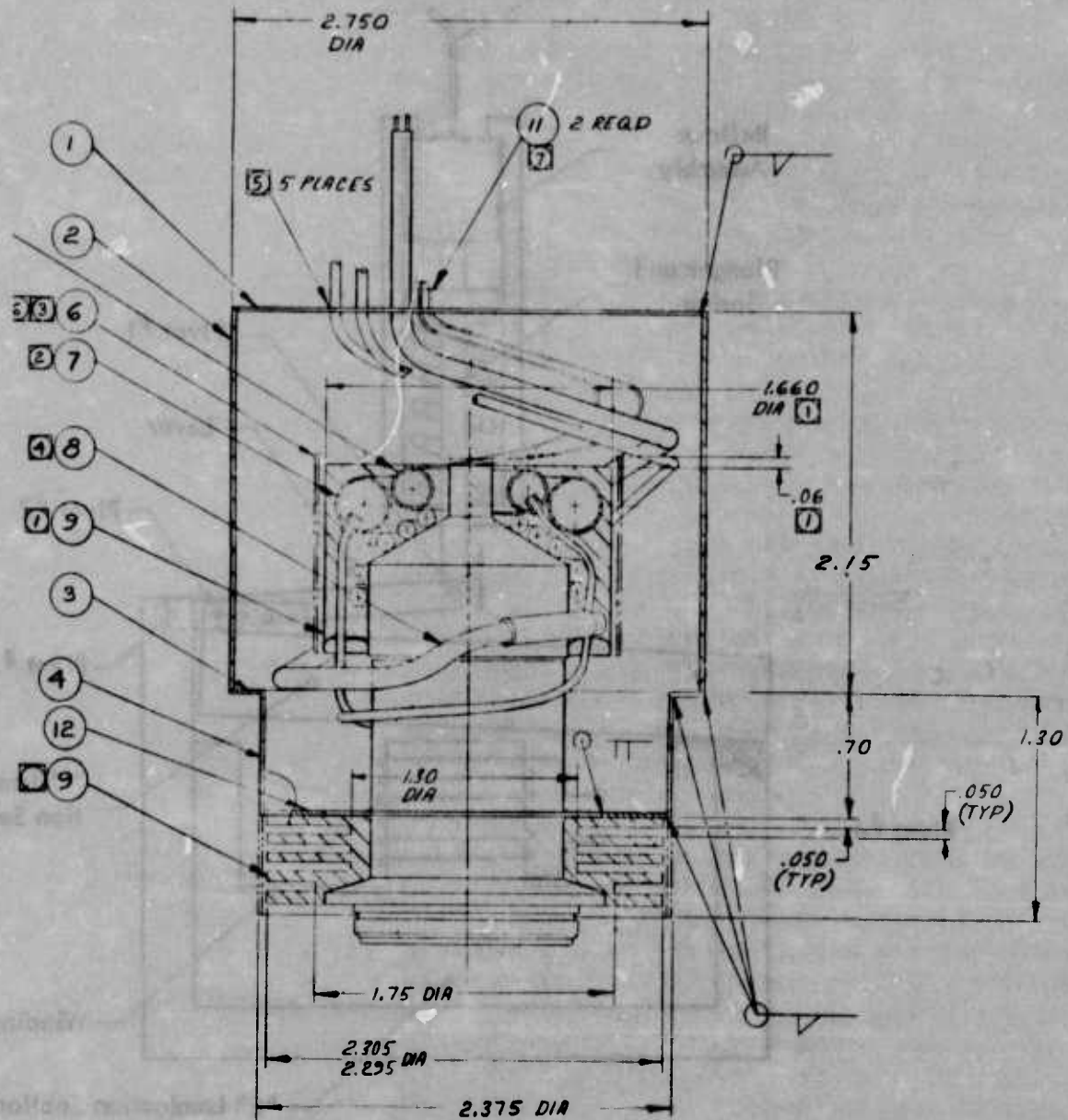

Figure 11 - Simplified Schematic of Inductor Assembly



operation, the various components at the hot end of the hot cylinder were tack-welded into place. These items include the heater (Item 8), two sensor bulbs (Items 7 and 10) and two thermocouples (Item 11).

The purpose of the copper fins at the base of the hot cylinder is to extract the last remaining portion of heat in the helium gas as it flows past the base of the cylinder and the associated base of the hot displacer. This, in effect, assures that the gas is as close to the ambient crankcase temperature as is possible. The purpose of the copper block at the top of the hot cylinder is many fold. It serves to integrate any variations which might occur in temperature due to cycling, if any, of the power into the hot cylinder heater. The copper block also assures uniform heat transfer from the heater into the two sensor bulbs (Items 7 and 10). The block also acts to integrate out any variations in temperature associated with the basic cycle frequency in the refrigerator. The basic cycle frequency in this refrigerator is at approximately 10 Hertz.

As is discussed later in this report, the brazing process which is used to cast the copper around the base of the hot cylinder and at the upper portion of the hot cylinder is very critical. A great deal of care must be exercised in this brazing process as copper is prone to go into solution with the hot cylinder material, Inconel 718.

After the brazing process has been accomplished to cast in the fin material at the lower portion of the cylinder, and the heat integrating portion at the top of the hot cylinder, there is a certain amount of final machining which is done. This final machining includes the adding of the fins at the base and the final finishing of the inside diameter of the hot cylinder itself. The finishing of the inside diameter of the hot cylinder is done after the brazing to take into account any distortion which might result from the brazing process. After the machining is done, the outer shell is welded into place around the cylinder. This outer shell is then filled with an insulating material, namely Refrasil. After this is accomplished, the upper lid (Item 1) is placed onto the can and is finally welded into place.

4. SAFETY SWITCH ASSEMBLY

The detail layout of the safety switch assembly is shown in Figure 13. As can be seen from the layout, the safety switch assembly is somewhat similar to the mechanism which is contained in the main controller. It consists, primarily, of a bellows assembly (Item 16), a motion transmitting shaft (Item 5), a bias spring (Item 12), and a microswitch (Item 9).

The safety switch assembly operates much in the same way that the main controller operates. The temperature sensing circuit consists of a sensor bulb connected through capillary tubing into the bellows assembly. This temperature sensing circuit contains toluene, as does the primary controller. The pressure within the temperature sensing circuit is again the function of the temperature at the hot end of the hot cylinder. As the temperature increases, the pressure within the sensing circuit increases. This pressure is transmitted down the main shaft of the safety switch assembly and operates against a bias spring. The pressure within the sensing circuit is converted into motion and as a maximum

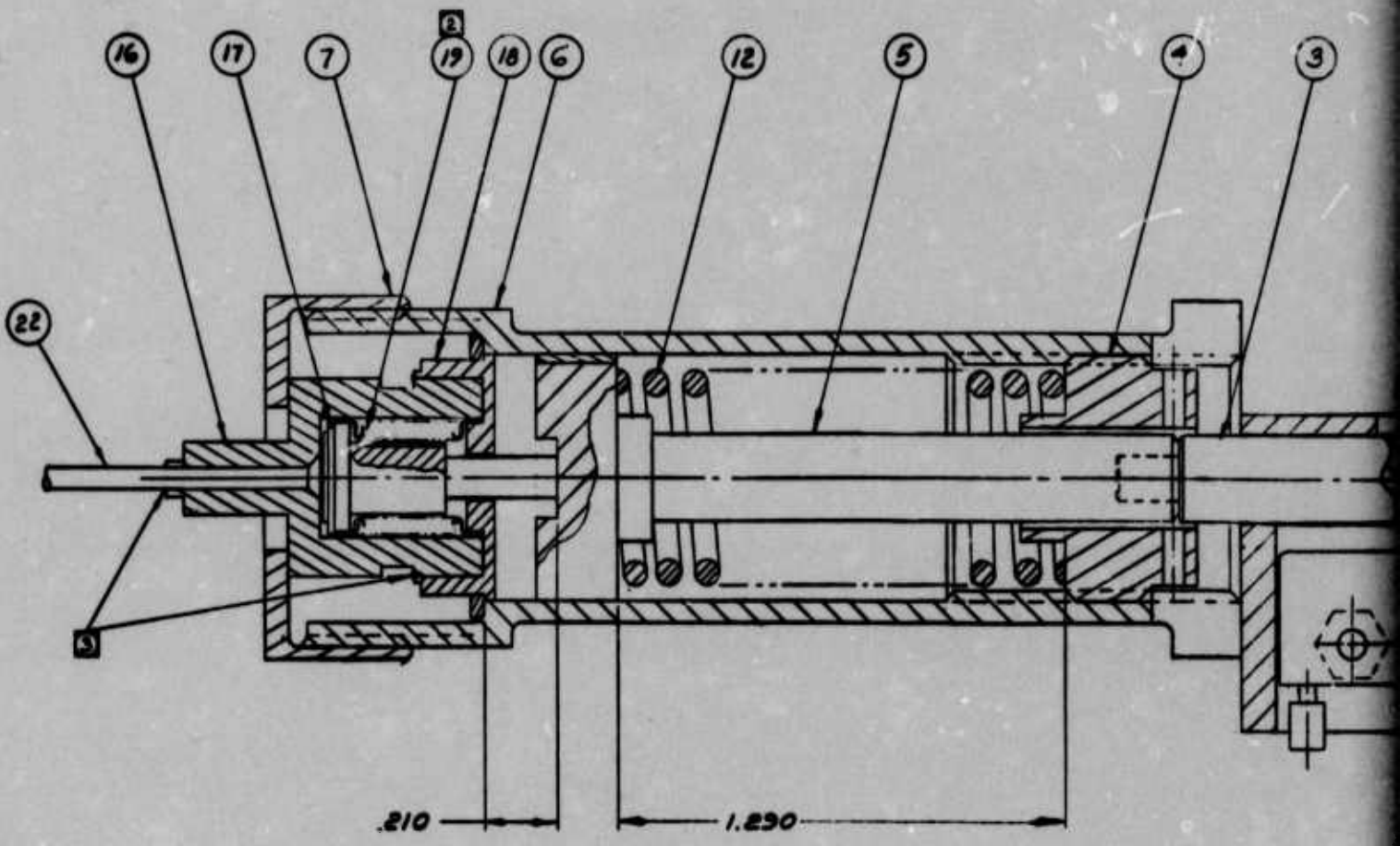

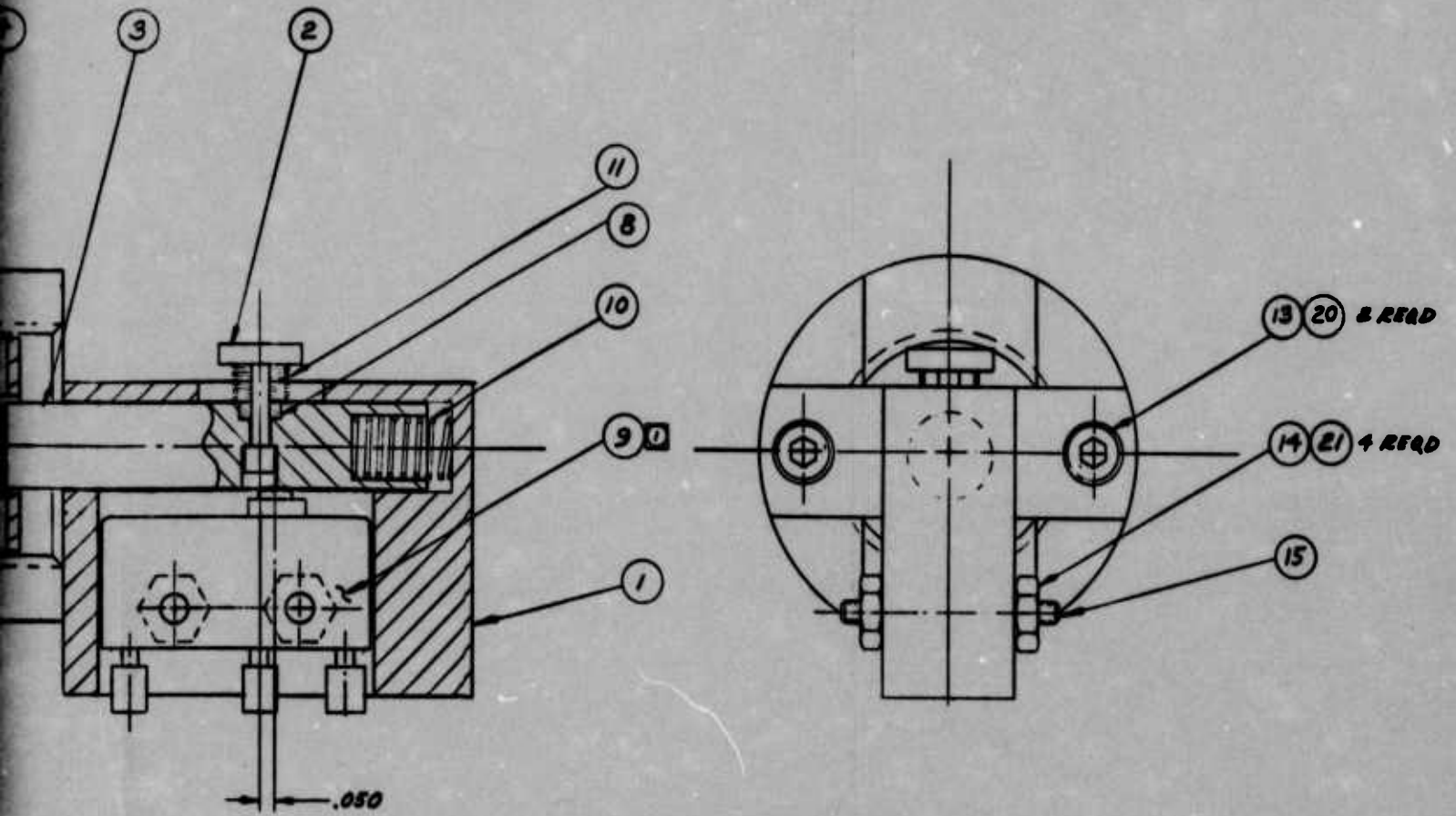

Figure 13 - Design Layout of Safety Switch Assembly

temperature is reached, the shaft actuates the microswitch. When this occurs, power is then removed from the hot cylinder heater circuit as this switch is electrically in series with the heater.

As seen in the drawing, the bellows assembly is very similar to the assembly which is contained in the primary controller. Liquid toluene is contained in the annulus between the bellows (Item 19) and the housing (Item 16). Force generated in the bellows assembly is transmitted down the bellows assembly shaft to the main driver shaft (Item 5). The force in the bellows assembly is counteracted by a spring (Item 12) which biases the main driver shaft towards its retracted position. The amount of force applied by the bias spring is adjustable by an adjustment nut (Item 4). The motion developed by the bellows/driver shaft is transmitted to a separate shaft (Item 3). This shaft contains a recessed hole into which a button on the microswitch can fall should that recess line up with the button. In normal operation, the shaft with the recess is forced to move with the main driver shaft (Item 5). However, should the main driver shaft position the recessed hole in the shaft (Item 3) such that the button on the microswitch falls into the recessed hole, then the actuator shaft is independent of the main driver shaft. This provides a lockout feature so that an overt action must be made to reset the system once it has been actuated due to an overtemperature condition. The reset operation is accomplished by depressing the actuator (Item 2) so as to allow the actuator shaft to be forced back into contact with the main driver shaft.

SECTION VI

DEVELOPMENT OF THE INDUCTOR ASSEMBLY

Developmental testing of the inductor assembly began with the hardware as described in Section IV. The test setup for performing the developmental testing on the inductor component to the temperature controller assembly is as shown in Figure 14. The primary objective of this testing was to determine the operating characteristics of the as-assembled inductor with respect to input voltage, load current, and the length of the air gap.

The inductor, as mounted in the assembly, contained 70 turns, #20 gauge wire, wrapped in approximately five layers. Using the test setup described above, the inductor was clamped in its fully closed position. In this condition, the inductor yielded the following voltage vs. current data, as shown in Table 6. After data were obtained with the gap in its fully closed position, shims were placed in the air gap to adjust the air gap length. These shims were selected in five milli-inch increments. The data from this test is shown in Table 7. Note that the data taken is with the inductor in its operating load condition, in that a 10.5 ohm load resistance is connected in series with the inductor. The data would indicate that adequate control range is obtained in the region from zero gap to between five and ten milli-inch gap. This is deduced from the fact that at zero gap the power in the load resistance is at approximately 90 watts, and at a gap length of between five and ten milli-inches, the power into the load resistance is at or above 160 watts. This power control range satisfied the requirements for the hot cylinder heater, as determined in the early empirical tests on the fully assembled refrigerator under the full ambient control range and set of operating conditions.

The next series of tests were performed by varying the air gap in the inductor by use of the bellows and motion transfer mechanism. The motion of the air gap was obtained by applying gas pressure into the bellows. The data obtained from these tests indicated that there was almost no control of the current into the load resistance by adjustment to the bellows pressure. The suspected problem was that the air gap was being modulated by the basic 400 Hertz excitation. In order to combat this, the bellows was filled with toluene to obtain a dashpot effect. The next series of tests again indicated that there was no control of the load current with a variation in the pressure applied into the bellows assembly. It was then found that the inherent compliance in the inductor assembly appeared to be a problem.

The compliance in the basic assembly was traced to the arm between the "I" laminations and the "E" laminations of the inductor. In order to correct this situation, a new pivot joint and a pivot arm were designed for this assembly. The flexure joint (Drawing #3148) is shown attached to the inductor assembly in schematic form in Figure 15. The purpose of this flexure joint is to incorporate a pivot point which is inherently free of compliance. In this particular case, the flexure joint is bonded to both the "E" section and the "I" section of the control inductor. The whole inductor assembly is then subsequently clamped into the final assembly. The lever arm (Drawing #3129, Rev. A) was

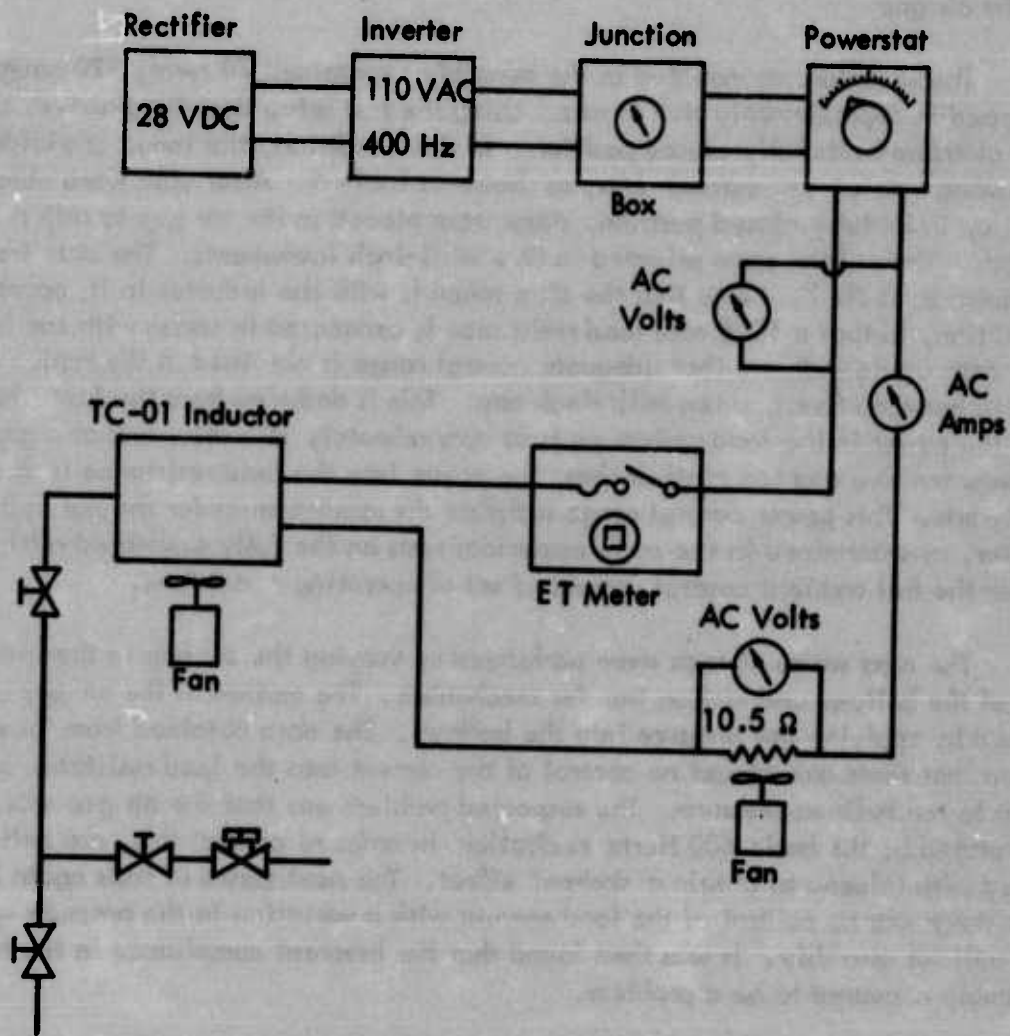

Figure 14 - Schematic of Control Inductor Test Setup

VOLTS	AMPS
120	3
100	1
109	2
120	3
131	4
140	4.7

Note: Air Gap = 0.0 inch
10.5 ohms load in series

**Table 6 - Current vs. Voltage Data for Control Inductor
With Zero Air Gap**

GAP LENGTH	VOLTS	AMPS
0.005	120	4
0.010	120	5
0.015	120	5.8
0.020	120	6.3

Note: 10.5 ohms load resistor in series

Table 7 - Current vs. Air Gap Length Data for Control Inductor

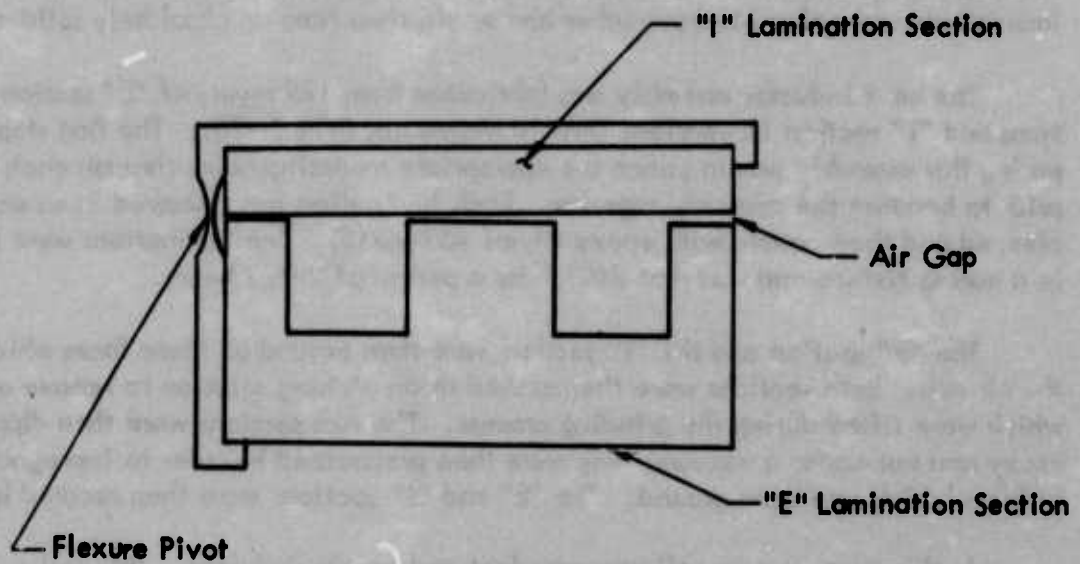

Figure 15 - Schematic of Flexure Joint/Inductor Assembly

refabricated in order to remove that portion of the compliance which was located in that element. This was done primarily by holding the pivot hole tolerances tighter.

The inductor was then reassembled into the temperature controller assembly and tested with pressure in the bellows to simulate actual operating conditions. This further testing again yielded unsatisfactory results. Again the current to the load was not controlled by introducing pressure into the bellows to adjust the length of the inductor air gap. Further inspection of the assembly indicated that compliance not only existed in the pivots (which was corrected by use of the flexure joint and the new lever arm) but also that the laminations themselves were loose. Upon finding this, it was decided that the next action should be to remanufacture the inductor in such a fashion that the laminations were glued to each other and would then form an absolutely solid assembly.

The next inductor assembly was fabricated from 175 layers of "E" section laminations and "I" section laminations (Arnold Magnetics P/N EI-75). The first step in preparing this assembly was to punch the appropriate mounting holes through each lamination prior to bonding the assembly together. Each lamination was deburred in an acid etch, cleaned and then coated with epoxy (Hysol A57-4315). The laminations were then stacked in a curing fixture and cured at 340° F for a period of 2-1/2 hours.

The "E" section and the "I" section were then ground on those faces which formed the air gap. Both sections were then soaked in an etching solution to remove any burrs which were lifted during the grinding process. The two sections were then dipped in the epoxy and put under a vacuum; they were then pressurized in order to impregnate those surfaces which had been ground. The "E" and "I" sections were then recured in the oven.

At this time, a new coil was manufactured for the inductor. This coil contained 75 turns of #20 AWG wire. These were stacked with 11 to 12 turns per layer, with approximately 6-1/2 layers. The inductor was then reassembled into the temperature controller and the performance measured with pressure in the bellows. The data in this test indicated that success had been achieved and that in the test setup, the inductor was able to vary the current over the range of 2.7 amps to 4.1 amps rms, well within the desired controllability range. The data is summarized in Table 8.

The inductor assembly, as previously described, was used throughout the remainder of the program. The only remaining change which was made in this assembly was to drill and tap several mounting holes in the "E" section and the "I" section. This was done in order to mount the flexure pivot to the inductor assembly with screws as opposed to using only epoxy (Armstrong A5). The epoxy which had been used to accomplish this bond joint was shown in the later stages of the program to weaken and fail under high temperature conditions. This failure would cause the control gap to close independent of bellows pressure.

AMPS	VOLTS	LOAD VOLTS	BELLOWS PRESSURE (psi)
4.1	120	68	-0-
3.85	120	64	120
3.6	120	62	140
3.4	120	60	156
3.2	120	58	170
3.0	120	56	184
2.7	120	54	200

Table 8 - Control Inductor Current vs. Fluid Circuit Pressure Data

SECTION VII

DEVELOPMENT OF THE BELLOWS ASSEMBLY

The initial testing done on the bellows assembly was done on the unit as described in Section V. Initial testing was performed with no power applied to the inductor. The primary purpose of performing these tests was to determine the non-operating air gap length which could be achieved by applying pressure into the bellows assembly. As noted previously, the design operating pressure point for the bellows assembly was at approximately 67 atmospheres, or roughly 1,000 psig. A representative set of data to indicate air gap length vs. pressure is indicated in Table 9. Note that the control pressure range occurs over approximately 240 psi.

Subsequent testing was accomplished with the bellows assembly attached to the inductor assembly, such that the bellows could vary the gap length of the inductor. It was during these series of tests that many leakage failures due to cracks were noted in the bellows assembly. It was determined that the bellows in the assembly was failing due to the high level of 800 Hertz vibration that was transmitted into the bellows from the air gap in the inductor assembly. The initial bellows (Miniflex Corp. P/N SS-250-40-71) used in the bellows assembly was made of stainless steel with a .004 inch wall thickness.

The bellows assembly was rebuilt after several failures with the .004 inch wall thickness bellows. A new bellows with .005 inch wall thickness (Miniflex Corp. P/N SS-250-50-164) was procured and put into this assembly. The spring rate on this new bellows was 164 lbs per inch as opposed to 71 lbs per inch for the previous bellows. The operating pressure range of the bellows assembly with this bellows was somewhat lower than that with the previous bellows. This is explained, primarily, due to the fact that the spring rate in this later bellows is higher. However, testing of this bellows assembly with the inductor also proved to be less than satisfactory as the bellows again leaked fluid due to cracks in the convolutions.

The bellows assembly was then reworked to include a new bellows (Mechanized Science Seals P/N 180019). This new bellows had a much lower spring rate and a very thin wall. The spring rate was on the order of 9 lbs per inch with a wall thickness of 1.2 milli-inch. In order to use this much thinner walled bellows, the system operating pressure was reduced to approximately 200 psi. However, again the tests which were conducted on this unit when connected to the inductor assembly were unsatisfactory. The bellows again leaked due to a crack in the convolutions. After several more bellows failures due to cracks in the convolutions, it was decided that a new bellows assembly had to be designed which would eliminate the excessive bellows flexing due to vibration. It was decided that the new bellows assembly must include an overt dashpot within the assembly. The layout of the newly designed assembly is shown in Figure 16. The bellows in this assembly (Mechanized Science Seal P/N 31.30-10.10) is also a thin wall bellows with a wall thickness of .0012 inch and a very low spring rate of 4.5 lbs per inch. The material from which these thin wall bellows were made is nickel, with a gold plating

DEVELOPMENT OF THE BELLOWS ASSEMBLY

The initial set of data on the bellows assembly was obtained from the tests described in Section II. Initial testing was performed with no control air gap length applied to the bellows. The results of this testing are shown in Table 9. It is noted that the pressure required to operate the bellows assembly with no control air gap length is approximately 700 psi.

GAP (inches)	PRESSURE (psi)
-0-	700
.002	550
.004	520
.006	490
.008	460

Subsequent testing was performed with the control air gap length applied to the bellows. The results of this testing are shown in Table 9. It is noted that the pressure required to operate the bellows assembly with a control air gap length of .002 inches is approximately 550 psi. The pressure required to operate the bellows assembly with a control air gap length of .004 inches is approximately 520 psi. The pressure required to operate the bellows assembly with a control air gap length of .006 inches is approximately 490 psi. The pressure required to operate the bellows assembly with a control air gap length of .008 inches is approximately 460 psi.

The bellows assembly was then tested with a control air gap length of .010 inches. The results of this testing are shown in Table 9. It is noted that the pressure required to operate the bellows assembly with a control air gap length of .010 inches is approximately 430 psi. The pressure required to operate the bellows assembly with a control air gap length of .012 inches is approximately 400 psi. The pressure required to operate the bellows assembly with a control air gap length of .014 inches is approximately 370 psi. The pressure required to operate the bellows assembly with a control air gap length of .016 inches is approximately 340 psi. The pressure required to operate the bellows assembly with a control air gap length of .018 inches is approximately 310 psi. The pressure required to operate the bellows assembly with a control air gap length of .020 inches is approximately 280 psi.

Table 9 - Control Inductor Air Gap Length vs. Fluid Circuit Pressure Data

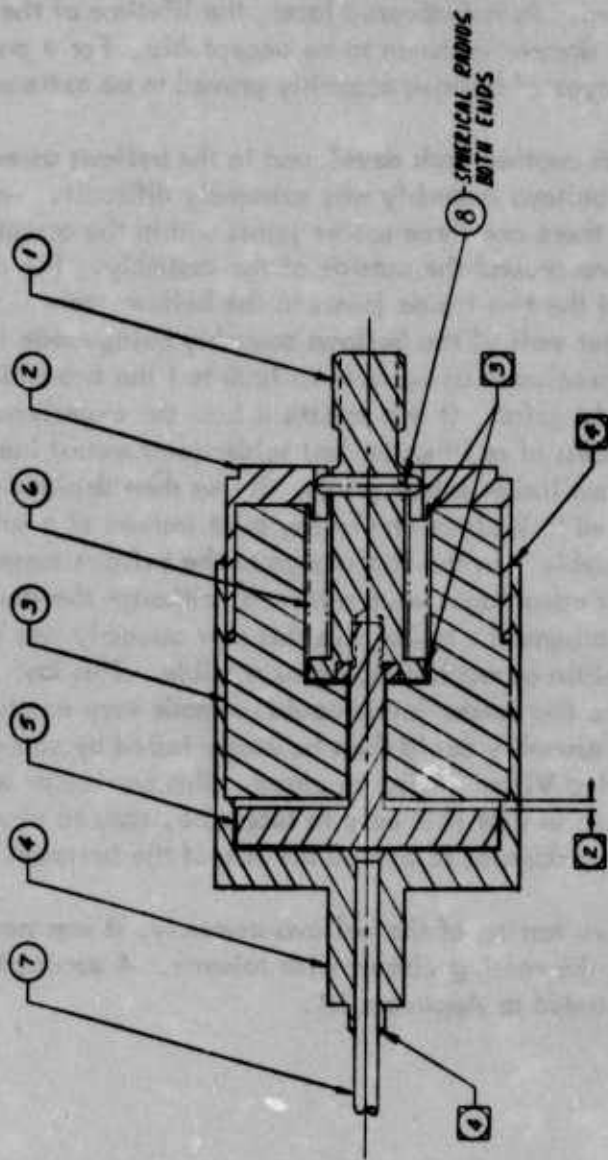

Figure 16 Design Layout of Modified Bellows Assembly

on the inner and outer surfaces. The method of attachment of these bellows into the assembly is with 60-40 lead-tin solder at a temperature not greater than 390° F.

As can be seen from the layout, the assembly specifically includes a dashpot. The clearance around the outer surface of the dashpot is on the order of .0005 inch. Because of the large surface area of the bellows and the large circumference, a great deal of damping is derived. As is indicated later, the lifetime of the thin wall bellows in this assembly with the damper is shown to be acceptable. For a great portion of the program, this particular type of bellows assembly proved to be extremely reliable.

Late in the program another leak developed in the bellows assembly. It was determined that repair of the bellows assembly was extremely difficult. As can be seen from the layout of Figure 16, there are three solder joints within the assembly, one at each end of the bellows and one around the outside of the assembly. The primary problem with this arrangement was that the two inside joints to the bellows were made in sequence, with the final joint on the outer wall of the bellows assembly being made last. The fact that this joint was made last precluded being able to leak test the two inside joints prior to having made the last solder joint. It was apparent from the experience of several soldering attempts that the process of making the last solder joint would inevitably open up a leak path in one of the two inside solder joints. It was then decided that this assembly should be again redesigned to include an O-ring joint instead of a solder joint as the last operation in the assembly. In the last design of the bellows assembly, as shown in Figure 17, the dashpot advantages were retained, although the dashpot itself is slightly smaller. The clearance around the bellows in this new assembly was reduced to less than 1/2 milli-inch to retain as much damping as possible. This last design proved to be simple to assembly; the two solder joints could be made very easily without upsetting any previous work. The assembly could then be easily tested by screwing on the cap of the bellows assembly with a Viton O-ring in place. This particular assembly is considered to be optimized in that it is easy to fabricate, easy to assemble, and retains the advantages of having a dashpot to extend the life of the bellows.

During the extensive testing of the bellows assembly, it was necessary to develop a procedure for charging the sensing circuit with toluene. A successful procedure for accomplishing this is included as Appendix III.

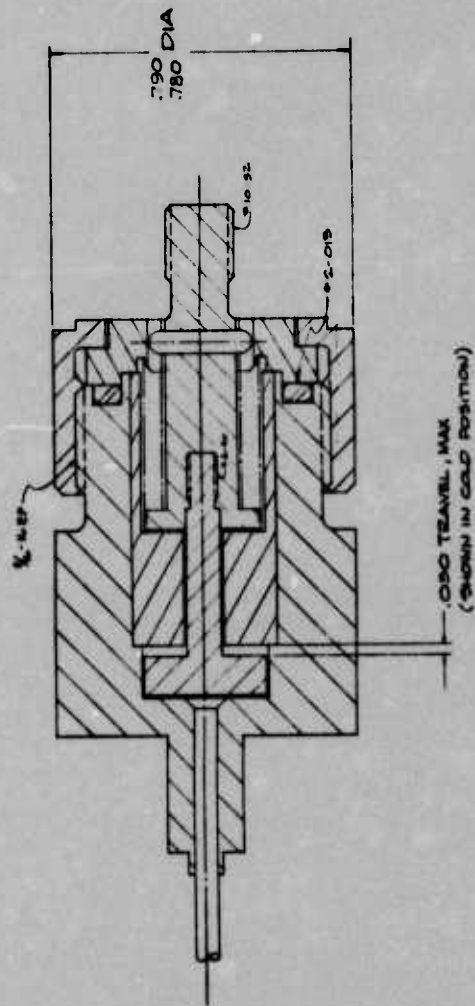

Figure 17 Design Layout of Further Modified Bellows Assembly

SECTION VIII

DEVELOPMENT OF THE HOT CYLINDER ASSEMBLY

As required in the contractual Statement of Work, the new hot cylinder was fabricated for the government furnished refrigerator early in the program. This cylinder was fabricated according to the configuration as described in Section V, Part 3. The configuration of this hot cylinder assembly remained fairly constant throughout the course of the program. The main deviations with respect to this cylinder occurred in the procedure followed in the brazing operations.

The first attempt at performing the brazing operation on a hot cylinder assembly was successful. In this procedure, the Inconel hot cylinder was plated using the Watts nickel plating process. The brazing molds were then welded to the hot cylinder. The heater and sensor bulbs were then attached by a spot welding technique involving the use of small stainless steel straps.

The brazing process used on this first cylinder was relatively uncontrolled. The mold was filled with common copper braze powder and placed in a hydrogen furnace. It was found that after this first brazing process, the copper powder had melted and only partially filled the mold. Subsequently, more braze powder was added and the assembly was placed in the furnace for further brazing. With each succeeding brazing operation, more braze metal was added into the mold. This first brazing operation required a total of four cycles through the braze furnace. This process, however, yielded an acceptable hot cylinder assembly which was used throughout the first several months of the program. However, during a test in which the hot cylinder was installed on the Vuilleumier refrigerator, the heater shorted to approximately 0.5 ohms.

The hot cylinder assembly was disassembled in order to examine the copper brazing at the heater end of the hot cylinder. It was found that the copper mass contained several large voids.

This failure, of course, necessitated the fabrication of a new hot cylinder. In the previous hot cylinder the heater resistance had been chosen at a value of 10.5 ohms. In the next assembly a more optimum heater resistance of 40 ohms was chosen.

The only deviation between the assembly for the second cylinder as compared to the first cylinder was that the stainless steel mold was increased in size so that more braze metal could be added initially. Thus, the brazing operation could be accomplished in one step, as opposed to the previous four-step operation. Again, the hot cylinder was Watts nickel plated to a thickness of .0007 to .001 inch. The assembly was then placed in a brazing furnace with the appropriate amount of brazing powder added to the mold. However, during the brazing process, the copper apparently went into solution with the Inconel, causing a failure to occur in the brazing process. The resultant assembly was useless as the solution process caused holes to appear in the Inconel hot cylinder.

The failed hot cylinder from this brazing process is shown in the photograph of Figure 18. The assembly was forwarded to the Air Force Flight Dynamics Laboratory where it was examined in detail. As a result of the study performed by Air Force personnel, one of the recommendations was a slight change in the configuration of the stainless steel mold which is welded to the hot cylinder. A change in the brazing process was also recommended.

The newly recommended brazing process included performing the brazing in a vacuum furnace. The procedure, as recommended by the Air Force Materials Laboratory, is as follows:

- 1) Clean the hot cylinder by pickling in an acid solution followed by thorough rinsing with water and drying with clean gas.
- 2) Fill both the upper and lower molds with copper welding rod (AWS A5.7, Class RCu) of 1/16 to 1/8 inch diameter, cut into lengths of about 1/4 inch.
- 3) Place a porous fire brick on top of the top mold.
- 4) Heat in a vacuum furnace as rapidly as possible to 2050° F. Hold at temperature for 10 minutes, then cool; the vacuum shall be 10^{-4} Torr or less until the temperature of 1950° F is reached. At that point, the pressure shall be increased to 10^{-3} Torr and held until the temperature is again cooled to 1950° F. The pressure shall be then decreased to 10^{-4} Torr or less during the remainder of the cooldown to room ambient.
- 5) Remove excess copper by machining.
- 6) Inspect the as-cast assembly using X-ray techniques to determine whether or not shrinkage voids have occurred.
- 7) Solution heat treat and age the assembly per AMS 5662B.

All steps of the recommended procedure were followed except that the hot cylinder was Watts nickel plated as recommended by the local vendor who performed the brazing process. The brazing process, however, was again a failure in that the copper again dissolved the Inconel, causing the molten copper to leave the mold.

Another hot cylinder assembly was fabricated and subsequently submitted to the Air Force Materials Laboratory to have the brazing process performed under direct Government cognizance. Preparation of the assembly was as described previously. The subsequent steps followed in performing this successful brazing process are as follows:

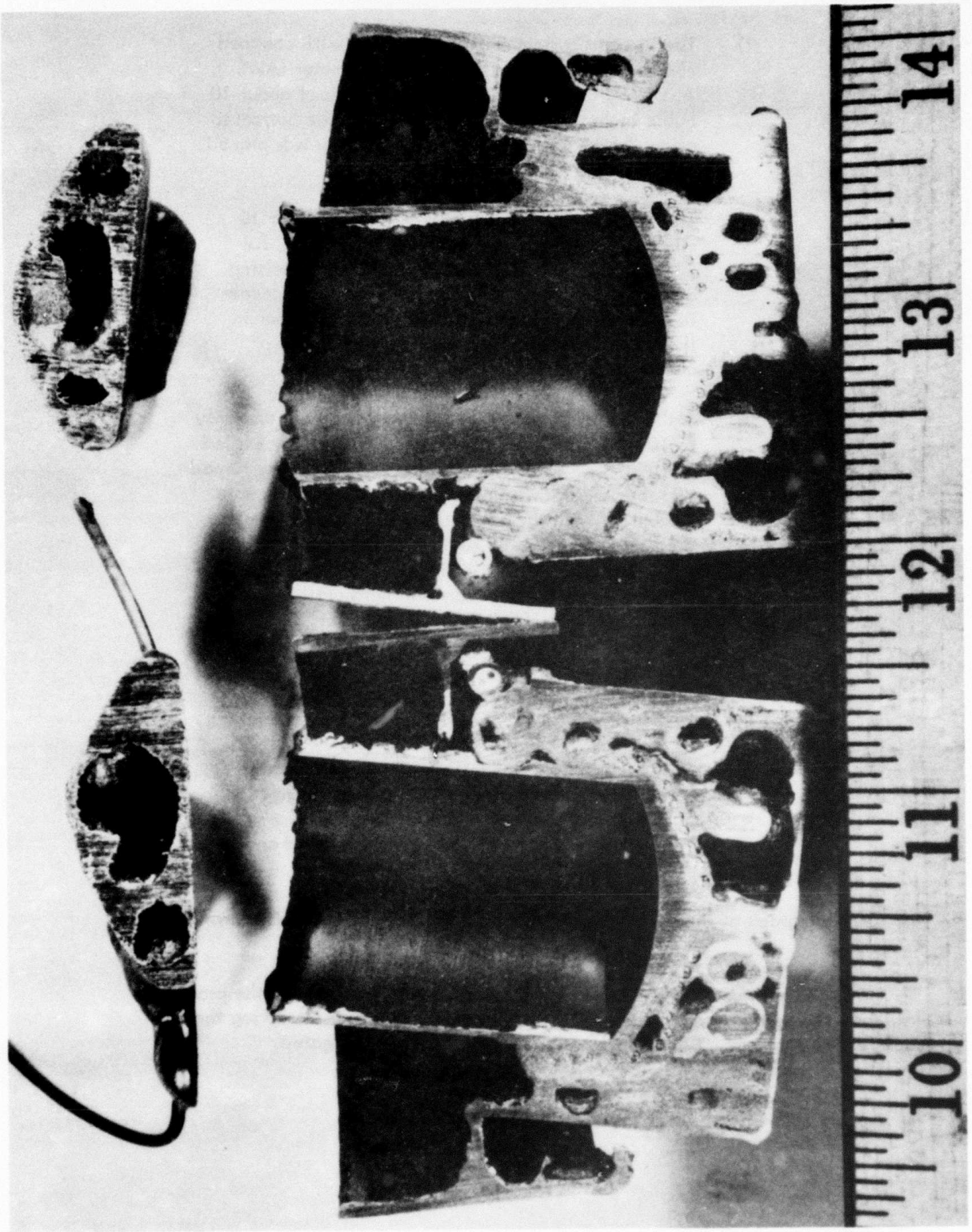

Figure 18 - Failed Hot Cylinder Assembly

- 1) The top and bottom molds were filled with chopped copper welding rod, 1/16 inch in diameter (AWS A5.7-69, Class RCu). Dense fire brick of about 10 cubic inches volume with a groove on the bottom to allow the escape of gases during heating was placed on top of the mold.
- 2) The first furnace run was made at 1090° C for 10 minutes. A second run was made at 1090° C for 20 minutes. After the first run, incipient melting of copper was found. After the second run, copper in the bottom mold had melted, but the copper in the top mold had experienced only incipient melting.
- 3) A third run was made by rapidly heating the assembly to 1095° C, held for 15 minutes, then slowly cooled to 1080° C. At that point, furnace power was turned off; temperature was measured with a thermocouple in contact with the hot cylinder near the copper in the bottom mold. The furnace pressure was held at 10^{-4} Torr until the hot cylinder cooled to 1065° C, then increased to 10^{-3} Torr and held until the temperature reached 1050° C. At that point, the pressure was then decreased to less than 10^{-4} Torr for the remainder of the cooldown.
- 4) Excess copper was removed from molds by machining.
- 5) The assembly was radiographed to inspect for the possibility of void volumes within the casting.
- 6) The assembly was then solution heat treated and aged per AMS 5662B.

A photograph of the successfully brazed hot cylinder assembly is shown in Figure 19.

This hot cylinder assembly was used throughout the remainder of the program. However, the heater again developed a low resistance short circuit during the final weeks of the program. The cause of this failure was not investigated.

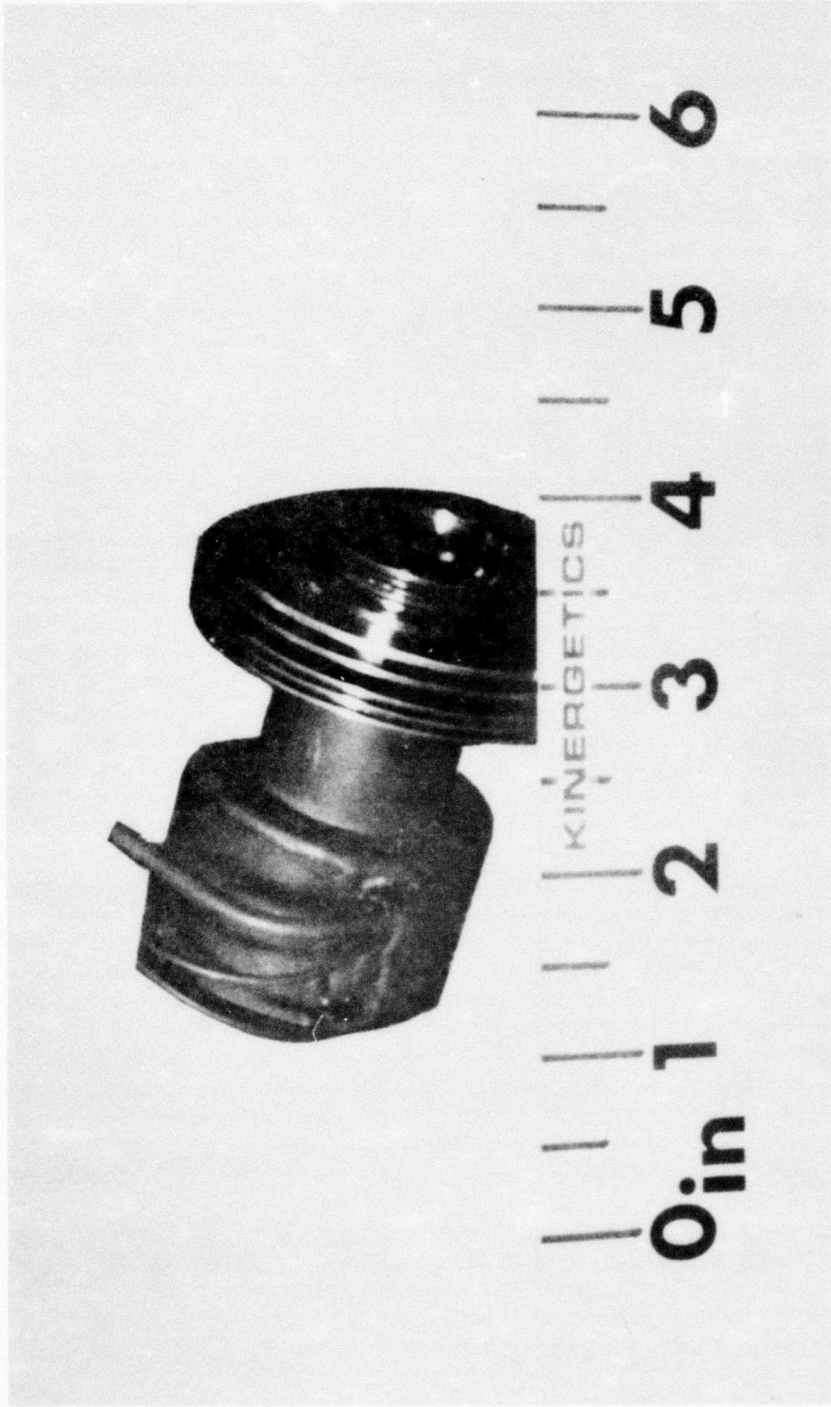

Figure 19 - Successfully Brazed Hot Cylinder Assembly

SECTION IX

DESIGN OF VARIABLE INDUCTORS FOR USE IN TEMPERATURE CONTROLLERS

As a result of performing the research and development of a variable inductive reactance temperature, several design aspects of the problem have become obvious. One of these aspects is the sizing of the variable inductor for use in the heater current control circuit.

The circuit schematic for this purpose is shown in Figure 20.

In this schematic, the load resistance R is the heater resistance of the hot end of a refrigerator hot cylinder. Of interest is the real power dissipated in the load resistor R. This is given by the basic relationship

$$P = I^2 R \tag{1}$$

where: P is power in watts,
I is current in amperes,
R is load resistance in ohms.

This is further expanded in terms of the circuit of Figure 20 as:

$$P = \frac{E^2}{R^2 + X_L^2} R \tag{2}$$

where: E is input voltage in rms volts,
 $X_L = 2\pi fL$,
f is frequency of source voltage in Hertz,
L is inductance of variable inductor in Henries.

The next parameter of interest in the inductor design is the range over which the power to the hot cylinder heater must be varied. As in the case of the government furnished refrigerator on this program, the power range was from 90 to 160 watts, or a range ratio of about two. In other, more efficient refrigerator designs where the hot cylinder dead load (that load when the refrigerator motor is not operating) is fairly low, the power range can vary by a factor of five (i.e., 25 watts to 125 watts).

The next parameter which enters into the design is the range over which the effective inductive reactance of the control inductor can be varied. In this program, the effective inductance used could be varied over a range ratio of about 1.5.

The remaining parameter of interest is the value of the heater resistance. In the case of the government furnished refrigerator, the heater resistance was 10.5 ohms. This

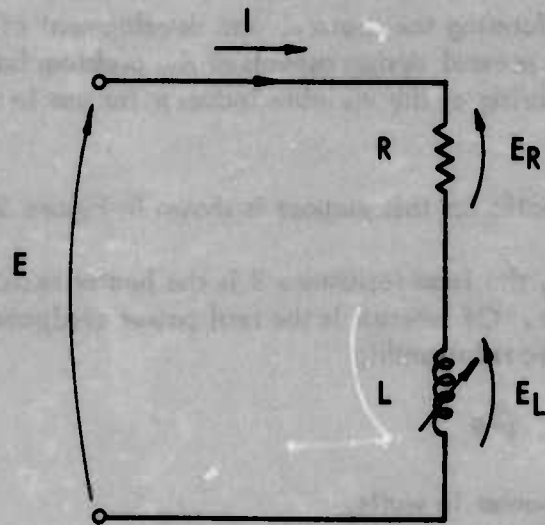

E is rms input voltage source

I is rms current

R is load resistance

L is variable inductance

E_R is rms load voltage

E_L is rms inductor voltage

Figure 20 - Circuit Schematic of Controller Circuit Model

value was preserved in the first hot cylinder which was fabricated. It was then changed to a more optimum value of 30 to 40 ohms.

These parameters can be combined in a relationship which will allow the value of the control inductance to be expressed in terms of the load resistance. To begin with, the power range ratio P_R can be expressed by

$$P_R = \frac{\frac{E^2}{R^2 + (X_L/k)^2} R}{\frac{E^2}{R^2 + X_L^2} R} \quad 3)$$

$$= \frac{R^2 + X_L^2}{R^2 + (X_L/k)^2}$$

where: P_{max} is the maximum heater power in watts,
 P_{min} is the minimum heater power in watts,
 k is the inductive reactance range ratio of X_L .

By solving this equation for X_L , one finds

$$X_L = \left[\frac{P_R - 1}{(1 - \frac{P_R}{k^2})} \right]^{1/2} R \quad 4)$$

$$= C_1 R$$

The significance of this equation becomes more apparent when one examines the variation of X_L in terms of P_R and k . The value of X_L increases with P_R and is minimized to a limiting value with increasing values of k . The inductive reactance X_L must be small in order to keep the overall system size small because most of the weight of the controller is concentrated in the inductor. Once values for P_R and k are established, X_L can be determined in terms of R . One can then return to the basic equation for power dissipation to find the actual circuit values for X_L and R :

$$P_{min} = \frac{E^2}{R^2 (1 + C_1^2)} R \quad 5)$$

or

$$R = \frac{E^2}{P_{\min} (1 + C_1^2)}$$

Once the optimum value for R and X_L have been found, one can then proceed with the inductor design. The value of the required inductance can be found from the basic equation

$$L_{\max} = \frac{X_L}{2\pi f} \quad 6)$$

Thus,

$$L_{\min} = \frac{L_{\max}}{k} \quad 7)$$

Up to this point, it has been assumed that the circuit elements under consideration are linear. However, in the controller system optimized for small size, it is advantageous to operate the control inductor well into saturation when in its maximum inductance condition. One can use the standard design equations for the design of power inductors (see Appendix IV) as an initial guide for sizing of the actual hardware. However, in most cases these equations assume linearity and will yield a design which in some cases is two to three times heavier than necessary.

A good material for use in power inductors is a grain oriented silicon steel (such as Arnold Magnetics M-6X). This is the material used in the inductor component for this program. The inductor was formed of modified "E" and "I" section laminations of .006 inch thickness (Arnold Magnetics P/N E1-75, .006 inch thickness). This particular type of material saturates at a flux density of about 15,000 Gauss. Also, in its useful linear range, the relative permeability μ_R is 20,000 or greater. However, in the inductor used on this program, it was found that one could push the inductor core into saturation to the point where μ_R was at or slightly less than 1,000. This number is useful in the design of other inductors for similar applications.

As indicated previously, initially the heater resistance R on this program was set at 10.5 ohms and E was set to be 115 volts rms at 400 Hertz. This particular set of conditions is optimum for small range of control inductor variation; the current range was to be 3 amps rms to 4 amps rms. This required an average inductive reactance charge of from 37 ohms to 27 ohms, a range ratio of 1.37. However, this set of conditions does not yield the smallest inductor given the condition that R is also a variable. This means that the inductor was handling from about 333 to 432 voltamperes reactive. In a more optimum design, the load resistor would be 49 ohms. The inductive reactance would range from 35 ohms to 69 ohms (this assumes $P_R = 2$ and $k = 2$); the inductor

would then be handling from about 112 to 126 voltamperes reactive . As inductor volume is roughly proportional to the reactive power handled, the inductor could have been smaller if a more optimum heater resistance option had been available .

SECTION X

EXTRAPOLATIONS TO OTHER APPLICATIONS

As required by the contractual Statement of Work, a design analysis is presented relating the affects of variations in heater power, hot cylinder diameter and source voltage on the design of a variable inductive reactance temperature controller. The ranges over which the noted parameters are of interest are

- Heater Power Dissipation - 200 to 1,000 watts
- Hot Cylinder Diameter - 1.0 to 5.0 inches
- Source Voltage - 28 to 115 volts rms at 400 Hertz

In presenting the analysis on these various parameters, constant reference is made to the equations presented in Section IX on inductor sizing. As will be seen, the primary first order effect on the controller design as a result of varying the noted parameters is in the size of control inductance. As the inductor is the largest single component in the controller, its size and weight dominate in the total assembly.

The primary effect of varying the maximum amount of power required in the hot cylinder heater is to linearly increase the volume of the controller as the power demand increases. Assuming that the source voltage remains constant, then the heater resistance would be resized according to equation 4) in Section IX. The current demand would, of course, increase, thus increasing the reactive power handled in the control inductor. As mentioned previously, the volume of the inductor is proportional to the amount of reactive power in the inductor.

Note that it has been implicitly assumed above that the power control range ratio stays constant as the maximum power demand increases. If this is not the case, the size variation may not be directly proportional to the power increases. If the range ratio decreases or increases, the effect can be evaluated in the sizing equation. If the range ratio decreases, the required control inductance value will likewise decrease, and vice versa. This will then vary the reactive power handled in the inductor at a rate which is either greater or less than the linear increase required in real heater power.

A dramatic effect on controller size is seen if the power range ratio is large (on the order of five or more). This requires that inductor performance remain linear over a greater range as the inductor air gap is varied to achieve control. This linearity requirement affects size, especially if the air gap is limited to a certain range. This is the case primarily in controllers using bellows mechanisms (in this program, a .006 inch gap variation was reasonable without overstressing the bellows).

The effect on the controller of variations in hot cylinder diameter are not directly obvious. If the increased diameter correlates to a larger refrigeration capacity machine,

the effect is directly relatable to increased power demand. This effect can be evaluated as in the previous discussion above.

However, if the diameter variation is in a machine in which refrigeration capacity is held constant, then the observations can be made that only cylinder losses will be affected.

The conduction loss in the hot cylinder is directly proportional to the diameter. However, if the cylinder is optimally designed, the cylinder thickness is such that the stresses are near maximum. Thus, if the diameter of the cylinder is increased, the wall thickness must be increased by the same factor to accommodate the additional stress. In this case, the cylinder conduction loss varies as the square of the cylinder diameter.

Under the assumption of constant refrigeration, the increase in hot cylinder diameter results in a shorter hot displacer stroke (displacement remains constant). Shortening of the displacer stroke reduces the shuttle loss down the hot cylinder. The shuttle loss is thus reduced inversely proportional to the cube of the cylinder diameter.

As can be seen, variation of cylinder diameter in this case represents an optimization of live and dead losses in the hot cylinder. The overall effect depends on the initial value of these losses in a given machine prior to the change in cylinder diameter. If all of these parameters are known, then one can make analytical judgments as to the effect made on heater power required at the hot end.

The effect on the controller of variation in the source voltage is nil to the first order if all other parameters remain constant. The effect is that the heater resistance and control inductance values must be decreased as indicated in the design equations. However, the size of the unit should remain essentially unchanged as the real power, reactive power, and power range ratio have remained constant.

SECTION XI

CONCLUSIONS AND RECOMMENDATIONS

It is concluded from the research and development performed on this program that the concept of controlling alternating current (AC) to a hot cylinder heater with a variable inductive reactance is indeed viable on a component basis. The viability is qualified since, on this program, a complete controller was never tested. Several recurring problems prevented these tests from being performed.

The program did result in the development of successful techniques for:

- copper brazing sheathed heaters to Inconel hot cylinders,
- fabrication of control inductors,
- design and fabrication of bellows actuators,
- charging of toluene fluid temperature sensing circuits.

It is recommended that if such a temperature controller system is considered for design and development in the future, several areas be given particular attention:

- Any bellows actuator should be well isolated from the vibration originating at the inductor air gap.
- All pivot joints associated with the control inductor should be designed to have minimum compliance and wear.
- The bellows assembly should be designed for ease of assembly and assurance of leak tightness.

It is further recommended that electronic controllers be given due consideration in this application. Several component developments in the recent past now make them acceptable for use in systems employing sensitive infrared detectors. These developments include

- cost effective precision solid state operational amplifiers,

- solid state AC switches (which will switch at zero current crossing).

The design of an electronic controller which operates from 24 volts DC is presented in Appendix V. It is estimated that an electronic controller could be designed to be lighter, more efficient, and as EMI free as a corresponding variable inductive reactance temperature controller.

A very useful follow-up effort to this program would be to develop temperature sensors with large signal outputs which could couple into electronic controllers. At present, the most economical sensor available is a simple thermocouple junction. The drawback to using thermocouples is their relatively low signal output; this requires precision amplifiers and references to adequately control the temperature.

An ideal candidate would be a device which utilizes a basic physical parameter change which occurs at the desired control temperature. Such a device might, for instance, use the Curie point in a magnetic material or a liquid to gas phase change in a liquid.

APPENDIX I

STATEMENT OF WORK

1. GENERAL

The contractor shall supply the required personnel, facilities, materials, and supplies to conduct the exploratory development program described in this attachment.

2. OBJECTIVE

The objective of this program is to design and fabricate a variable inductive reactance temperature controller for control of and retrofit with the power cylinder of a 77° K Vuilleumier cycle cryogenic refrigerator. The assembly shall be tested after retrofit to demonstrate feasibility and functional performance of the controller in regulating VM hot cylinder temperature. Technology necessary for designing a reliable, small, inexpensive controller will be developed and reported.

3. BACKGROUND

The VM refrigerator produces cryogenic temperatures using heat as the primary input power. For aircraft usage the heat is produced by electrical heaters. The refrigerator hot end is normally designed to operate between 1200° F and 1300° F for maximum efficiency consistent with metallurgical limits of the power cylinder materials. Changes in heat rejection temperature, refrigerative load, displacer motor speed, and input voltage affect the amount of input power required by the heater. If the power input is not regulated, the hot end temperature will not stay within design limits. Various electronic controlling methods have been used to regulate input power. On-off electronic controllers produce high EMI and large heater temperature cycles that adversely affect heater life. High frequency pulse width modulating proportional controllers are large, expensive, inefficient (consumes 10 to 15% of the power they control), produce relatively large amounts of EMI and have large numbers of components that lead to reliability limitations.

A need exists for a hot cylinder temperature controller that does not have the unfavorable characteristics of the electronic controllers. This effort is to develop a flight weight, inexpensive, efficient, EMI-free and reliable temperature controller to regulate VM cooler hot cylinder temperature under aircraft environmental and voltage varying conditions.

4. WORK TO BE PERFORMED

4.1 The contractor shall conduct analytical and/or experimental studies of the following considerations to provide information for the design of the temperature controller described in paragraph 4.3 of this attachment.

- 4.1.1 Use of RTV rubber, other similar materials and dashpots as damping devices.
- 4.1.2 Use of gas or liquid (no phase change) as the controller fluid.
- 4.1.3 Method of minimizing the controller moving mass.
- 4.1.4 Method of minimizing capillary and bellows volume while maximizing area on which the gas pressure acts.
- 4.1.5 Selection of appropriate controller fluid pressure.
- 4.1.6 Use of two bellows in opposition to eliminate the affect of ambient temperature changes on plunger core travel.
- 4.1.7 Use of diaphragms or bellows.
- 4.1.8 Manual adjustment to assure repeatability of control temperature.

4.2 The contractor shall fabricate a new hot cylinder with attached heater which shall be fitted to the GFP 77° K VM cooler. The heater resistance shall be selected to provide an estimated maximum 200 watts to the hot cylinder when powered through the controller described in paragraph 4.3 of this attachment using prime power type specified in paragraph 4.3.1.5 of this attachment. The cooler shall then be tested while power input to the hot cylinder is controlled manually. The high and low power input required to regulate the hot cylinder temperature at a point between 1200° F and 1300° F to within $\pm 50^\circ$ F shall be measured while the cooler is operating in the environments specified in paragraph 4.5 of this attachment. These tests will be conducted with the temperature controller gas bulb and capillary tube attached to the hot cylinder. Required power input to maintain this temperature shall, by extrapolation, be estimated when the cooler is operated in ambients to -65° F and 160° F.

4.3 Using the analysis specified in paragraph 4.1 of this attachment, the contractor shall design, fabricate, assemble, and test a variable inductive reactance temperature controller. The temperature controller shall basically consist of a gas bulb, capillary tube, bellows, Belleville return spring, ferromagnetic plunger core, redundant safety switch, dashpot, and coil winding. The temperature controller shall meet the specifications of paragraph 4.3.1 of this attachment.

4.3.1 Temperature Controller Specifications

4.3.1.1 Temperature - The temperature controller shall control hot cylinder temperature at a point between 1200° F and 1300° F to within $\pm 50^\circ$ F by regulating power to the hot cylinder heater.

4.3.1.2 Envelope - The temperature controller volume shall not exceed 8 in³.

4.3.1.3 Weight - The temperature controller weight shall not exceed 2 pounds.

4.3.1.4 Efficiency - The temperature controller shall dissipate less than 12% of the power it controls at any power input control level.

4.3.1.5 Power - The temperature controller shall use 400 Hz, 115 +3/-5 volts.

4.3.1.6 EMI - The temperature controller shall be designed to meet the electromagnetic interference requirements defined by applicable parts of MIL-STD-461A (incorporated by reference) and shall be designed to meet the following additional EMI control specifications: (1) No signals in the bandwidth about the center frequency of 45 Hz shall be generated; (2) The temperature controller shall be inherently linear and free of repetitive transients; (3) A one inch diameter single loop connected to a low noise pre-amplifier optimized for a 20 ohm source shall be passed along all outside surfaces and appendages at a distance not greater than three inches from the surfaces and appendages. The noise figure of the amplifier shall not exceed 3 DB. Measurable interference levels between 10 Hz and 160 Hz shall not exceed 0.06 μ V rms and peak-to-peak spikes shall be less than 0.2 μ V more than 90% of the time.

4.3.1.7 Fluid Retention - The temperature controller shall meet the temperature specification without adding fluid to the controller for a period of time not less than 600 hours.

4.3.1.8 Safety Switch - The temperature controller shall be designed such that any controller failure will result in power termination or prohibit powering of the refrigerator in such a manner that power cannot be restored to the refrigerator without manual reactivation. Reactivation shall not involve the replacement of any parts or components of the controller assembly.

4.3.1.9 Environment - The temperature controller shall be designed to perform as specified in this attachment when subjected to the following environmental conditions as described in MIL-STD-810B (incorporated by reference):

Temperature - Altitude	Class 1	Procedure 1
Vibration	Aircraft, except helicopters	Procedure 1 Parts 1, 2 and 3 Fig 514-1, Curve C
Acceleration	Aircraft and helicopters	Procedure 1 and 2 Paragraphs 3.2.4 and 3.3.4

4.3.2 Temperature Controller Performance Test

The temperature controller shall be tested at ambient temperatures of -65° F, 14° F, 86° F, 122° F and 160° F. The temperature controller shall be vibration tested in accordance with MIL-STD-810B, equipment category (b), procedure 1, parts 1, 2 and 3, Figure 514-1, Curve C, time schedule 514-11, schedule 1. The temperature

controller shall also be acceleration tested in accordance with MIL-STD-810B, procedure 1, paragraphs 3.2.4 and 3.2.5 and procedure 2, paragraphs 3.3.4 and 3.3.5. These tests shall be performed with the controller regulating power to the hot cylinder heater (not attached to cooler). The controller shall provide power input to the heater at the rates determined in accordance with paragraph 4.2 of this attachment.

4.4 Instrumentation

The contractor shall instrument the hot cylinder described in paragraph 4.2 of this attachment with temperature detectors capable of repeatedly measuring the hot cylinder temperature change to within $\pm 5^\circ$ F and the hot cylinder absolute temperature to within $\pm 25^\circ$ F. The hot cylinder shall be instrumented with two temperature detectors located on the heater sheath.

4.5 Temperature Controller and Cooler Assembly Test

The assembly shall be tested every 40° F between 0° F and 120° F and simultaneously, prime voltage shall be varied between 110 volts AC and 118 volts AC and cold tip load shall be varied between no load and two watts with the cooler operating, the temperature of the hot cylinder shall be controlled in accordance with paragraph 4.3.1.1 of this exhibit. In addition, the assembly shall be subjected to cursory EMI tests (MIL-STD-461A, Class A1, emission only).

4.6 Design Data

The contractor shall analyze the affects on the controller design of varying the following parameters:

- a) Maximum power input - 200 watts to 1000 watts
- b) Hot cylinder diameter - 1" to 5"
- c) Voltage - 28 VAC to 115 VAC

4.7 Data Delivery

The contractor shall deliver all data in accordance with the requirements, quantity and schedules set forth in the contract data requirements list.

APPENDIX II

AMBIENT TEMPERATURE COMPENSATING BELLOWS DESIGN EQUATIONS

The basic sensor which was suggested in this proposal was a gas bulb coupled to a bellows movement to drive a mechanical device as shown schemotically in Figure 21. Operation of this type of device is quite straightforward. As the temperature of the gas bulb increases, the pressure of the gas in the system also increases which causes the bellows to undergo a slight movement.

However, the simple bellows gas bulb system has one drawback; the amount of gas in the bellows cannot be made small enough in respect to the amount of gas in the bulb, therefore, the system will be somewhat responsive to the temperature that surrounds the bellows as well as that of the bulb. To compensate for this, an opposing bellows system is used, as shown in Figure 22. The sizing of the two bellows is chosen so that the change in ambient temperature has a negligible effect over the total loading of the system.

If one considers that the bulb/bellows assembly can be represented by two volumes, V_1 and V_2 , at temperatures T_1 and T_2 respectively, the pressure in the system can be shown to be:

$$P = \frac{\frac{MRT_2}{V_2}}{1 + \frac{T_2}{T_1} \frac{V_1}{V_2}} \quad 8)$$

where: subscript 1 refers to the bellows,
 subscript 2 refers to the bulb,
 R is the universal gas constant,
 M is the total mass in the system.

Therefore, the force on the system is:

$$F_1 = PS = \frac{\frac{MRT_2}{V_2} S}{1 + \frac{T_2}{V_2} \frac{V_1}{T_1}} \quad 9)$$

where: S is the effective bellows area.

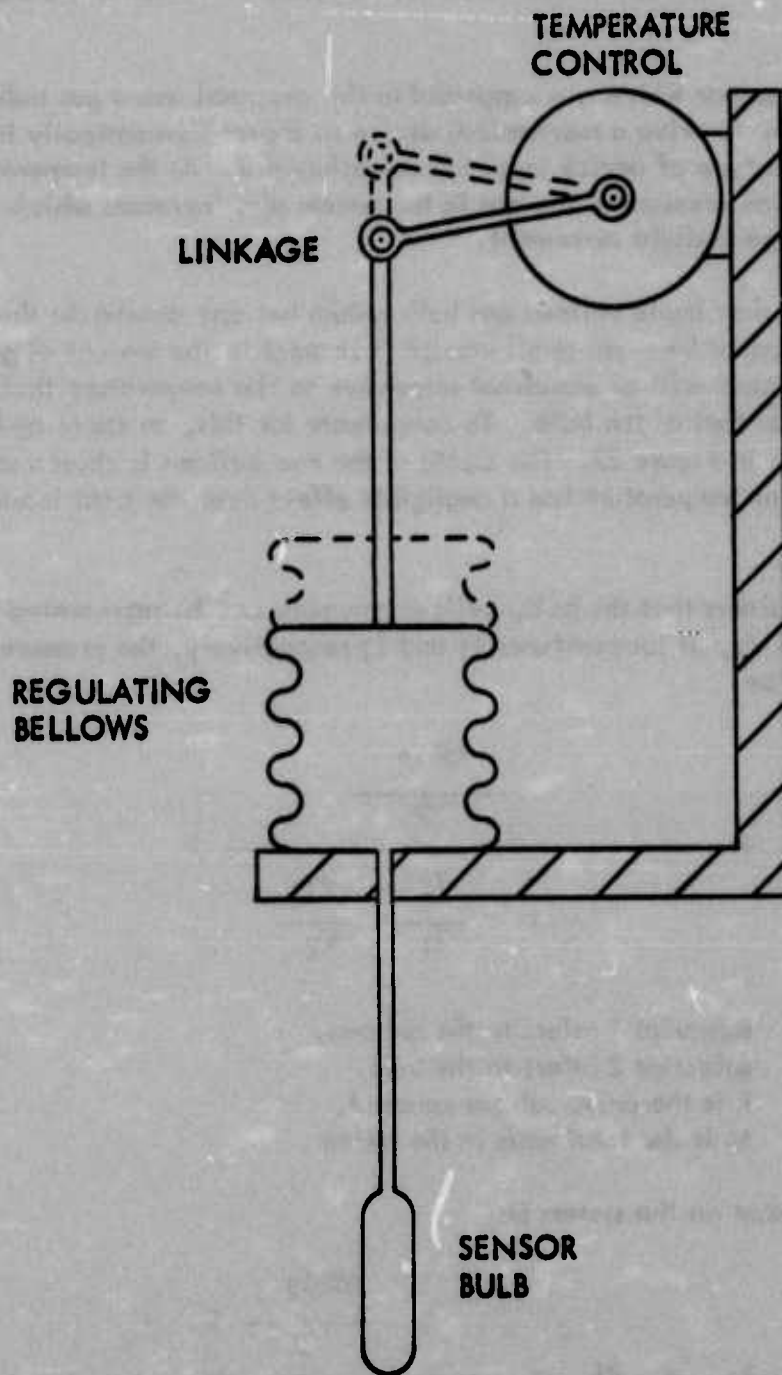

Figure 21 - Schematic Diagram of Single Bellows Temperature Regulator

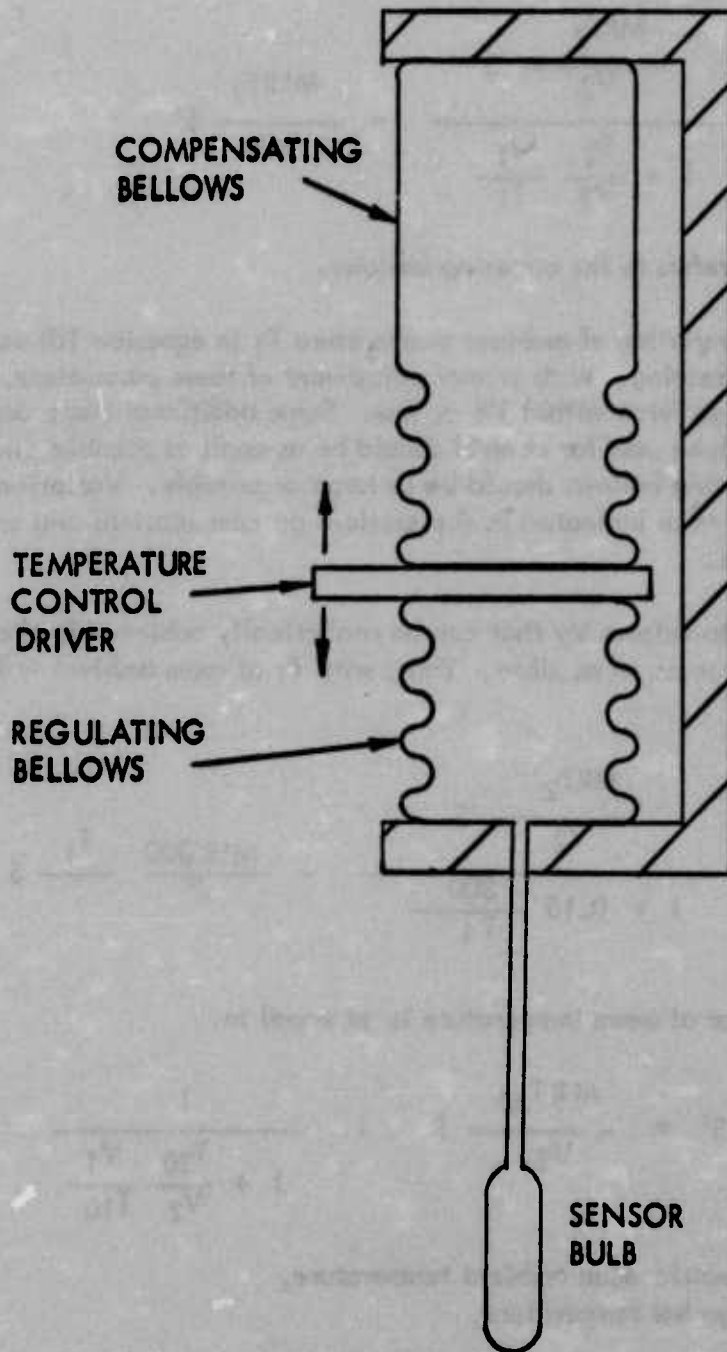

Figure 22 - Schematic Diagram of Compensated Bellows Temperature Regulator

If this assembly is opposed with a bellows at ambient temperature, the total force on the system is:

$$\begin{aligned}
 F &= F_1 - F_2 \\
 &= \frac{\frac{MRT_2}{V_2} S}{1 + \frac{T_2}{V_2} \frac{V_1}{T_1}} - \frac{M'RT_1}{V'} S' \quad 10)
 \end{aligned}$$

where: V', M', S' refers to the opposing bellows.

It may be seen that the variation of ambient temperature T_1 in equation 10) varies each term of ten in opposite direction. With proper adjustment of these parameters, it is possible to maintain the design force within 1% or less. Some additional basic design considerations are that the bellows used for control should be as small as possible and the gas chamber used for compensating bellows should be as large as possible. Variation design compromises are employed as indicated in the sections on computations and an overall convergence is feasible.

The ratio of Volume V_1 to volume V_2 that can be realistically achieved is about 1:20 if the bellows at T_1 is filled as much as possible. Thus, with T_1 at room ambient $\approx 300^\circ \text{K}$ and $T_2 = 925^\circ \text{K}$,

$$F = \frac{\frac{MRT_2}{V_2} S}{1 + 0.15 \frac{300}{T_1}} - \frac{M'R 300}{V'} \frac{T_1}{S}$$

If the design compensating force at mean temperature is set equal to:

$$\frac{MRT_{10}}{V'} S' = \frac{MRT_{20}}{V_2} S \quad 1 - \frac{1}{1 + \frac{T_{20}}{V_2} \frac{V_1}{T_{10}}}$$

with T_{10} = geometric mean ambient temperature,
 T_{20} = design hot temperature,

then the total force is:

$$F = \frac{\frac{MRT_2}{V_2} S}{1 + \frac{T_2 V_1}{V_2 T_{10}} \frac{T_{10}}{T_1}} - \frac{\frac{MRT_2}{V_2} S \frac{T_1}{T_{10}}}{1 + \frac{T_2 V_1}{V_2 T_{10}}}$$

If it is assumed that the control is perfect, T_2 is constant, then the variation of force at the control as the ambient temperature shifts from 165° F (347° K) to -65° F (220° K)

$$F_{280} = \frac{MRT_2}{V_2} S \frac{1}{1 + .165} - .14 =$$

$$\frac{MRT_2}{V_2} S \times (0.716)$$

$$F_{347} = \frac{MRT_2}{V_2} S \frac{1}{1 + .133} - .18 =$$

$$\frac{MRT_2}{V_2} S \times (0.703)$$

$$F_{220} = \frac{MRT_2}{V_2} S \frac{1}{1 + .21} - .112 =$$

$$\frac{MRT_2}{V_2} S \times (0.714)$$

Thus, one finds that this variation is less than 2%, or $\pm 1\%$.

APPENDIX III

PROCEDURE FOR CHARGING OF THE TOLUENE SENSING CIRCUIT

The following procedure was developed to fill the sensing circuit of both the primary and safety controllers with toluene fluid. Figure 23 shows the pneumatic schematic for the procedure. Figure 24 shows the electrical schematic for applying power to the hot cylinder. The step-by-step procedure is as follows:

- 1) Clean all tubing which will contact toluene with acetone. Blow these elements dry with clean, dry nitrogen.
- 2) Connect the circuits, both electrical and pneumatic, as shown. The tubing in the crimp zone of the toluene circuit is to be .125 inch diameter by .020 wall stainless steel. The toluene reservoir is 1/4 inch stainless steel tubing, approximately 24 inches long.
- 3) Clean the crimp zone with sandpaper and tin the zone with solder.
- 4) The pneumatic circuit should then be tested for leaks.
- 5) Remove the toluene reservoir from the circuit, keeping mount #1 attached to the reservoir.
- 6) Fill the toluene reservoir and partially drain through valve #1 to remove all trapped gases. Refill reservoir with valve #1 closed.
- 7) Reconnect the toluene reservoir and valve #1 into the circuit, being sure to tighten all fittings to prevent leaks.
- 8) Activate the roughing pump and open valve #2. Allow the pump to operate on the system for at least two hours, with the hot cylinder at a temperature of at least 1000° F.
- 9) Adjust the helium gas regulator on the helium bottle to 100 psi. Note that the toluene reservoir must always be positioned such that the helium is above the liquid toluene.

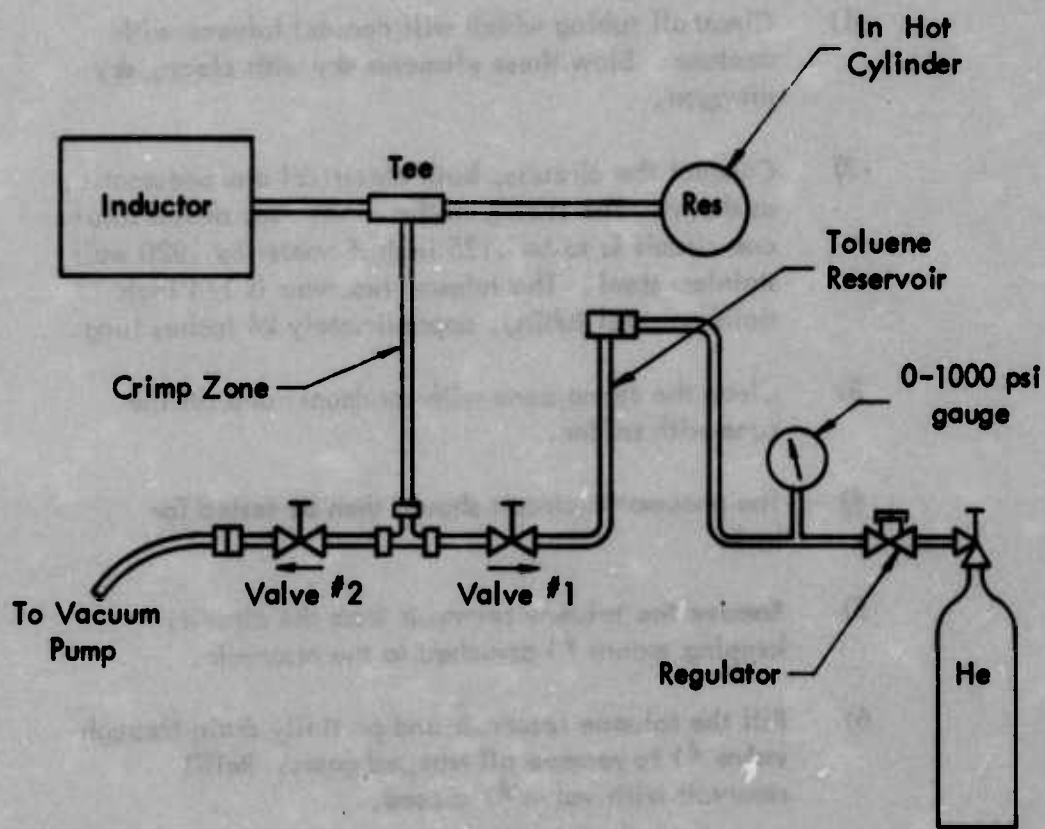

Figure 23 - Pneumatic Schematic of Toluene Charging Setup

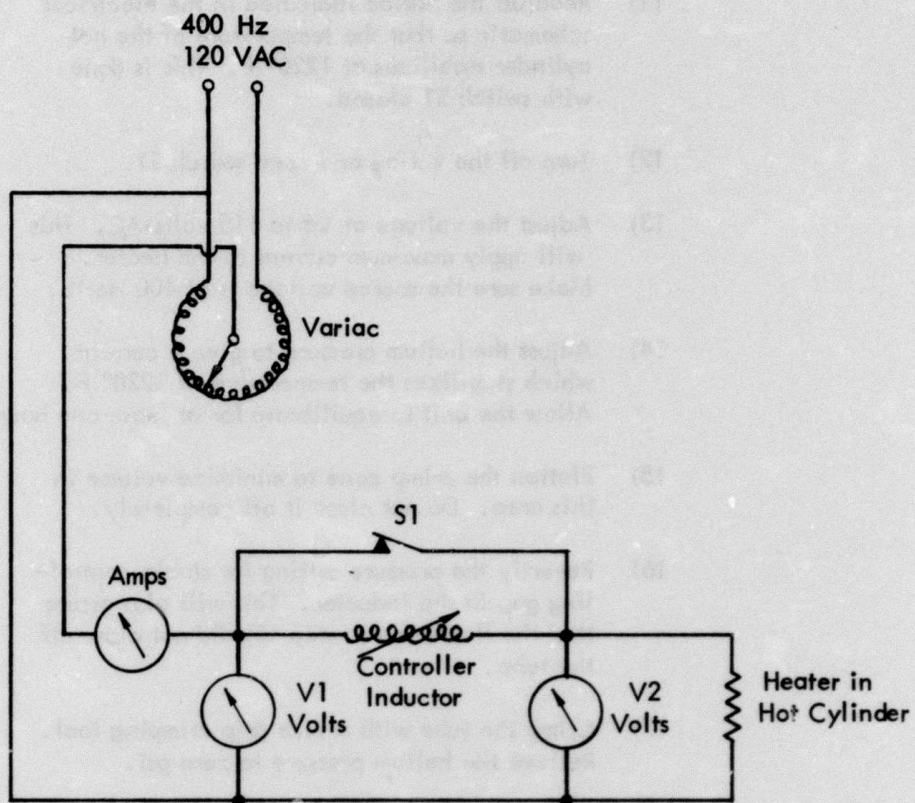

Figure 24 - Electrical Schematic of Toluene Charging Setup

- 10) Close valve #2 to the vacuum pump and slowly open valve #1.
- 11) Readjust the variac indicated in the electrical schematic so that the temperature of the hot cylinder stabilizes at 1220° F. This is done with switch S1 closed.
- 12) Turn off the variac and open switch S1.
- 13) Adjust the voltage at V1 to 115 volts AC. This will apply maximum current to the heater. Make sure the source voltage is at 400 Hertz.
- 14) Adjust the helium pressure to give a current which stabilizes the temperature at 1220° F. Allow the unit to equilibrate for at least one hour.
- 15) Flatten the crimp zone to minimize volume in this area. Do not close it off completely.
- 16) Reverify the pressure setting for stable controlling gap in the inductor. This will also assure that the flattening in step 15) did not close off the tube.
- 17) Crimp the tube with a vice grip crimping tool. Relieve the helium pressure to zero psi.
- 18) Cut off the crimped tube in the flattened portion.
- 19) Heat the flattened end of the crimp-off tube to boil out the remaining toluene and solder closed, using a non-acid flux.
- 20) Check to see that the controller is operating properly.

APPENDIX IV

LINEAR POWER INDUCTOR DESIGN EQUATIONS

As indicated, the following equations assume linearity of circuit operation. Sinusoidal circuit excitation is also assumed.

The inductance of an inductor configuration is given by

$$L = 0.4\pi N^2 \mu_R \frac{A_e}{L_e} \times 10^{-8} \quad (11)$$

where: L is inductance in Henries,
 N is the number of turns of wire on the core,
 μ_R is the core relative permeability ($\mu_R = 1$ for air),
 A_e is the effective core cross-sectional area in cm^2 ,
 L_e is the effective core magnetic path length in cm.

The flux density achieved in the core is given by

$$B = \frac{E \times 10^8}{4.44 f N A_e} \quad (12)$$

where: B is magnetic flux density in Gauss,
 E is sinusoidal voltage excitation in volts rms,
 f is excitation frequency in Hertz.

These two equations can be combined to give a relationship between flux density B and core volume V_e

$$B = \frac{2500 E}{f L V_e} \mu_R \quad (13)$$

where: $V_e = A_e L_e$, the effective core volume in cm^3 .

This equation can be used to determine the size of the core which is required for a given inductance L and a voltage drop E . The parameters which are bounded by the core material itself are the flux density B and relative permeability μ_R . The core material will accept a maximum value of flux density B_{max} beyond which will put the core into the saturation region of operation.

If an air gap is introduced in the magnetic circuit, then the effective magnetic path length L_e is affected very strongly. The effective path length for small gaps ($L_g \ll A_e$) is given by

$$L_e = L_c + \mu_R L_g \quad 14)$$

where: L_c is magnetic path length of the core,
 L_g is length of the air gap,
 μ_R is relative permeability.

The above equations apply for inductor designs in which there is only AC excitation. If AC plus DC current is expected to flow in the inductor, this must be taken into account in the design. In this case

$$B = \frac{0.4\pi N I_{max} \mu_R}{L_e} \quad 15)$$

where: B is flux density in Gauss,
 I_{max} is peak current flow in amps (AC + DC),
 N is turns of wire,
 μ_R is relative permeability,
 L_e is effective magnetic path length in cm.

APPENDIX V

DESIGN OF AN ELECTRONIC TEMPERATURE CONTROLLER

The block diagram for an electronic temperature controller is shown in Figure 25. The controller accepts thermocouple junction inputs from the hot cylinder. Since the control of the hot cylinder is important from a safety standpoint, this portion of the circuit is parallel-redundant. The circuits are powered from a voltage regulator which conditions the primary 24 ± 4 volts DC down to a very constant and noise-free 18 volts DC.

Because of the safety hazard involved, the hot end heater controller circuitry is redundant. In most cases, a circuit failure will cause the controller to cut off power to the heater. To guard against those circuit failures which will allow power to the heater to be continued, there are two parallel channels which can independently cut off power to the heater by opening up series switches.

Circuit schematic details for the blocks in Figure 25 are shown in Figures 26 through 28.

The schematic of one of the hysteresis type comparators, set up for a thermocouple input, is shown in Figure 26. The input of this circuit is devised to provide a precision reference voltage which is compared to the thermocouple voltage. A potentiometer adjustment is provided to set the reference voltage to correspond to the desired control temperature.

The A1 amplifier circuit provides amplification and filtering prior to the main comparator. Comparator A2 is configured to have hysteresis by positive feedback through resistor R14. This is done to insure that the controller operates in a true "on-off" (as opposed to proportional) manner.

The schematic of Figure 27 is for the ramp generator and series switch. The purpose of this circuit is to slow the change in voltage applied to the heater. Thus, the heater current is "ramped" on and off at a rate of about 5 amperes per second. This is done to prevent the current change from interfering with any EMI-sensitive devices which may be located near the refrigerator.

The ramp circuit is made up of integrated circuit A1, level shifter Q1 and current amplifier Q2. Feedback to effect the ramp change in output is provided through capacitor C2.

The series switch is the heat sink mounted transistor Q3.

The diagram of Figure 28 is of the voltage regulator. It is based on the use of an integrated circuit which contains all necessary components except stability adjusting capacitors and output-voltage adjusting resistors.

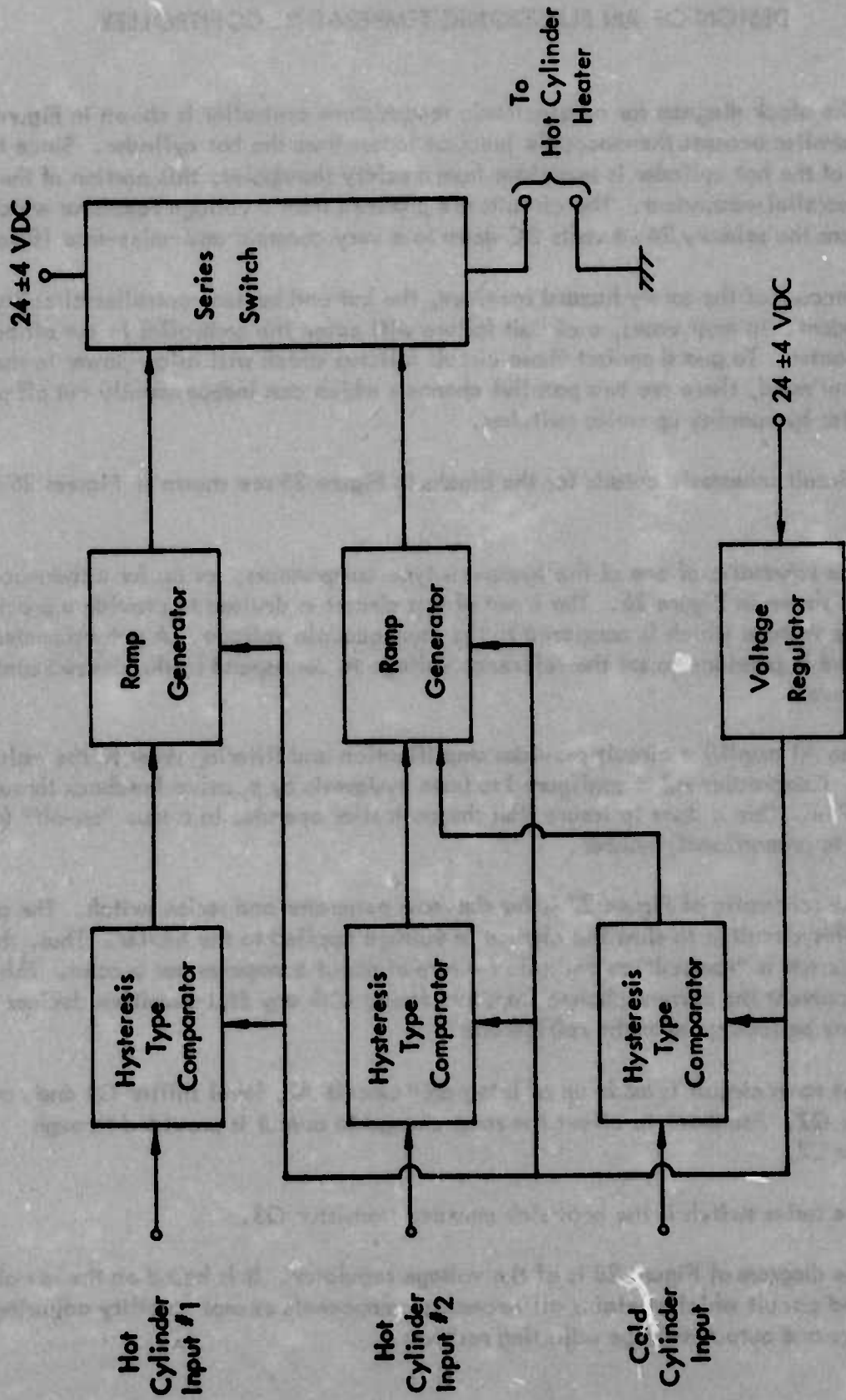
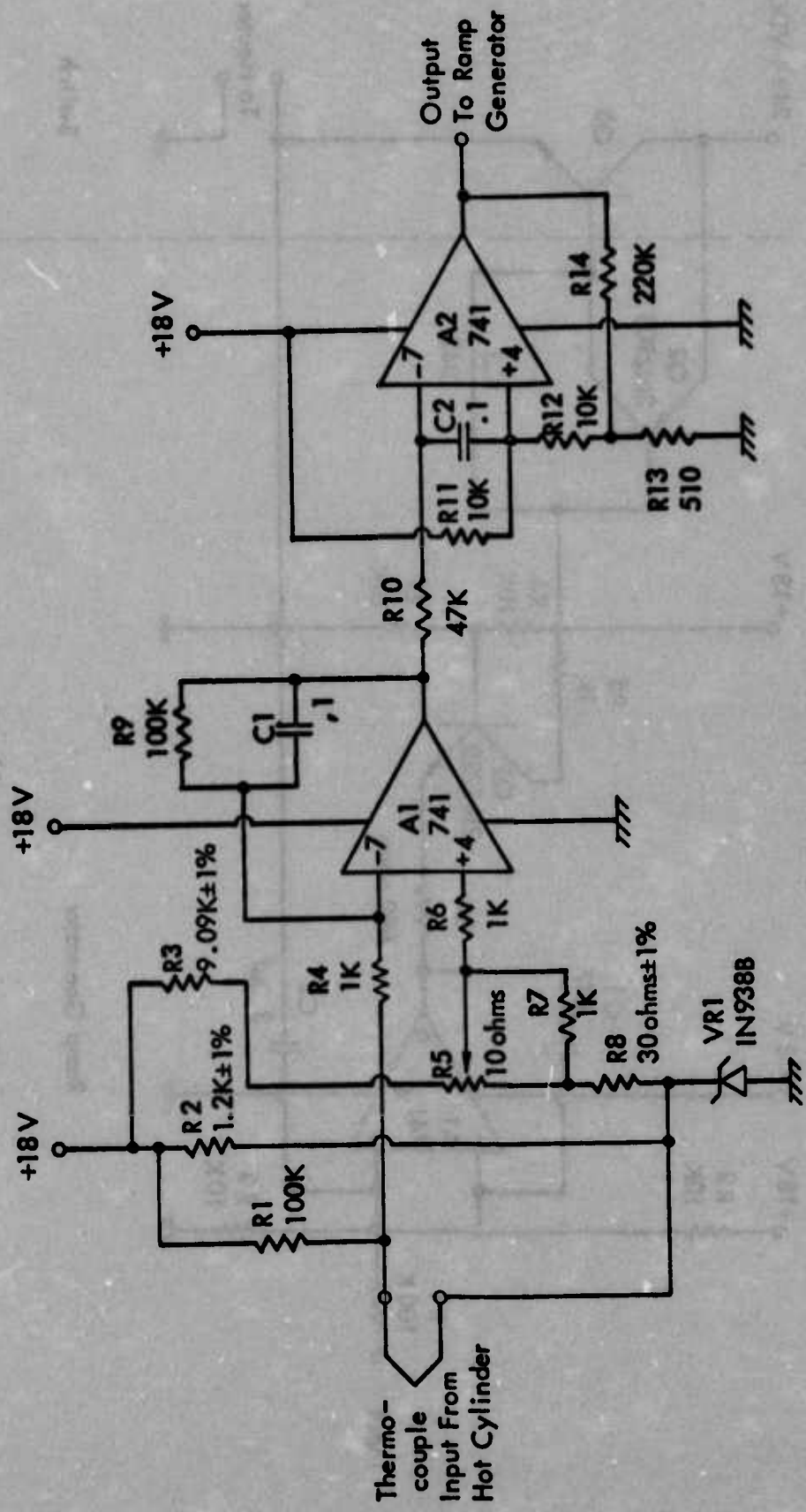

Figure 25 - Block Diagram of Controller



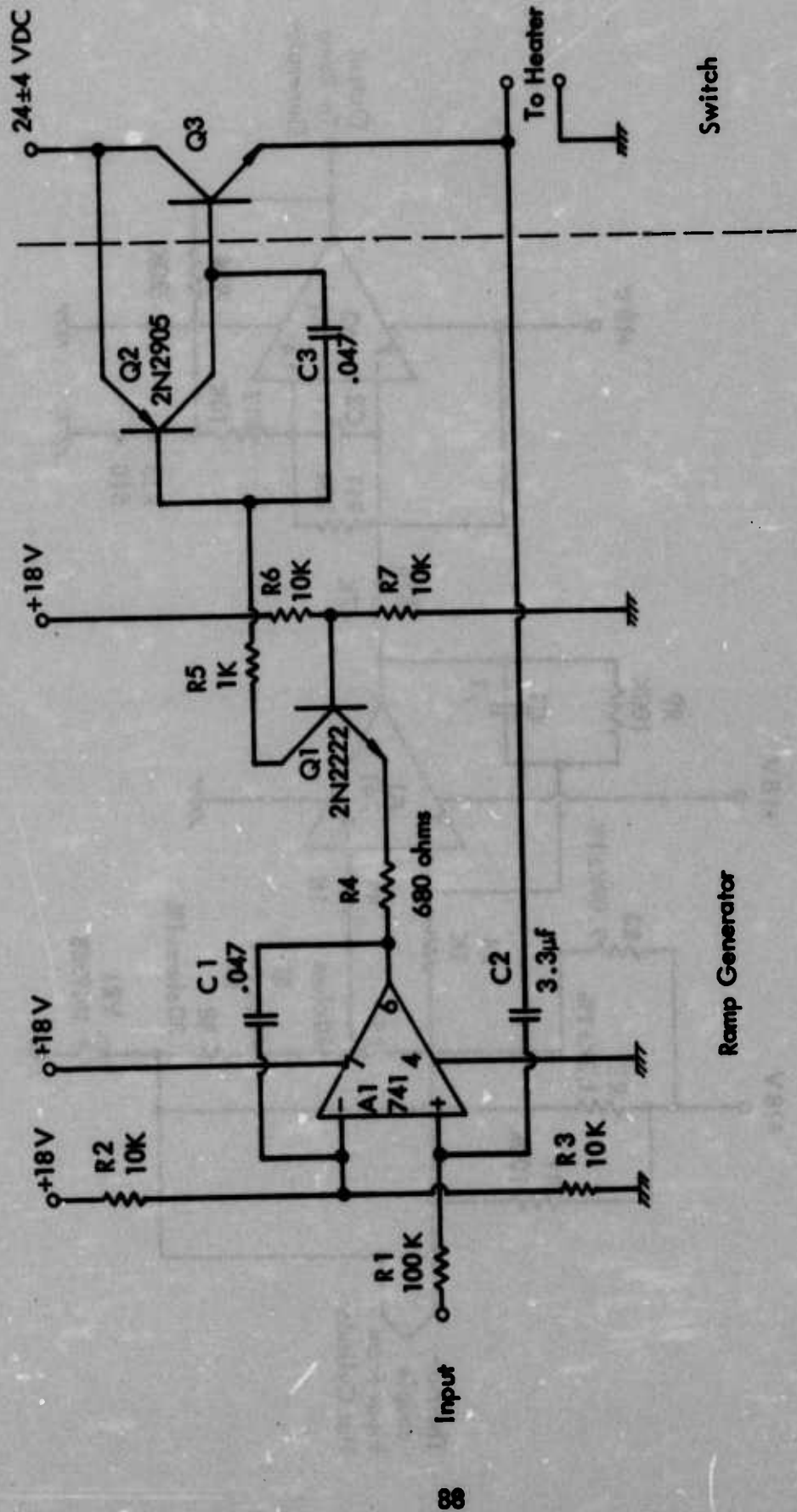

Figure 27 - Schematic of Ramp Generator and Series Switch

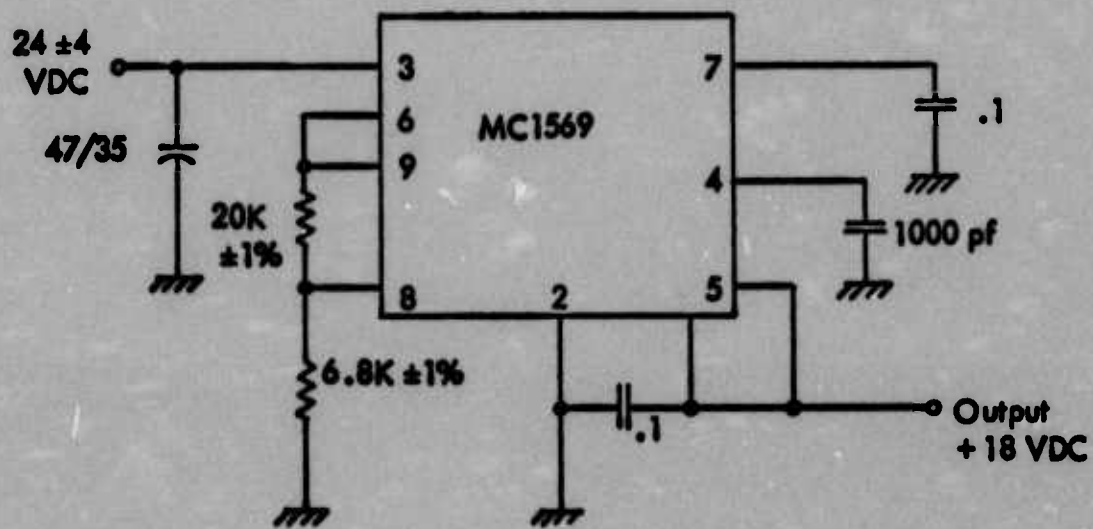

Figure 28 - Schematic of Voltage Regulator

The power dissipated in this circuit is minimal. The bias power for the signal processing electronics is less than two watts. The power dissipated in the series switches is, of course, proportional to the load current (the voltage drop across the switches is a constant two volts in the conducting mode). For a 125 watt heater, this controller dissipates only 10% of the power it controls.

