

UNCLASSIFIED

AD NUMBER

ADB004561

LIMITATION CHANGES

TO:

Approved for public release; distribution is unlimited.

FROM:

Distribution authorized to U.S. Gov't. agencies only; Proprietary Information; MAY 1975. Other requests shall be referred to Office of the Director of Defense Research and Engineering, Washington, DC 20301.

AUTHORITY

ODDR&E ltr 9 Sep 1975

THIS PAGE IS UNCLASSIFIED

THIS REPORT HAS BEEN DELIMITED
AND CLEARED FOR PUBLIC RELEASE
UNDER DOD DIRECTIVE 5200.20 AND
NO RESTRICTIONS ARE IMPOSED UPON
ITS USE AND DISCLOSURE.

DISTRIBUTION STATEMENT A

APPROVED FOR PUBLIC RELEASE;
DISTRIBUTION UNLIMITED.

✓

AFSWC-TR-74-29, Vol. I

AFSWC-TR-
74-29
Vol. I

ADB004561

HITVAL SYSTEM SCORING TEST REPORT

Volume I

Test Results and Analysis

May 1975

Final Report for Period October 1973 - November 1974



Distribution limited to US Government agencies and contractors directly involved in the HITVAL Program because the report contains data and information concerning a Joint Operational Test and Evaluation Program involving Soviet anti-aircraft weapons (May 75). Other requests for this document must be referred to ODDR&E (TSTE), Wash, DC, 20301.

**JOINT ARMY/AIR FORCE PROJECT HITVAL and
OFFICE OF THE DIRECTOR OF DEFENSE, RESEARCH, AND ENGINEERING
Washington, DC 20301**

**AIR FORCE SPECIAL WEAPONS CENTER
Air Force Systems Command
Kirtland Air Force Base, NM 87117**

This final report was prepared by the Air Force Special Weapons Center and was a joint Army-Air Force effort. Colonel Philip J. White was the Air Force Deputy Test Director. Colonel Edgar F. Todd, Hq TRADOC, was the Army Test Director-in-Charge.

When US Government drawings, specifications, or other data are used for any purpose other than a definitely related Government procurement operation, the Government thereby incurs no responsibility nor any obligation whatsoever, and the fact that the Government may have formulated, furnished, or in any way supplied the said drawings, specifications, or other data is not to be regarded by implication or otherwise as in any manner licensing the holder or any other person or corporation or conveying any rights or permission to manufacture, use, or sell any patented invention that may in any way be related thereto.

This technical report has been reviewed and is approved for publication.

FOR THE COMMANDER

FOR THE COMMANDER

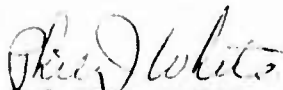
PHILIP J. WHITE

Colonel, USAF
Deputy Test Director
4900th Test Group (Flt Test)

EDGAR F. TODD

Colonel, USA
Test Director-in-Charge
Hq TRADOC

UNCLASSIFIED

SECURITY CLASSIFICATION OF THIS PAGE (When Data Entered)

REPORT DOCUMENTATION PAGE		READ INSTRUCTIONS BEFORE COMPLETING FORM
1. REPORT NUMBER AFSWC-TR-74-29, Vol I	2. GOVT ACCESSION NO.	3. RECIPIENT'S CATALOG NUMBER
4. TITLE (and Subtitle) HITVAL SYSTEM SCORING TEST REPORT, Vol I, Test Results and Analysis		5. TYPE OF REPORT & PERIOD COVERED Final Report; October 1973 - November 1974
7. AUTHOR(s)		6. PERFORMING ORG. REPORT NUMBER
9. PERFORMING ORGANIZATION NAME AND ADDRESS Air Force Special Weapons Center (FTH) Kirtland AFB, NM 87117		8. CONTRACT OR GRANT NUMBER(s)
11. CONTROLLING OFFICE NAME AND ADDRESS ODDR&E (T&E) Washington, DC 21305		10. PROGRAM ELEMENT, PROJECT, TASK AREA & WORK UNIT NUMBERS 921H0300; DDR&E Joint Test HITVAL (Charter, 12 Feb 73)
14. MONITORING AGENCY NAME & ADDRESS (if different from Controlling Office)		12. REPORT DATE May 1975
		13. NUMBER OF PAGES 134
		15. SECURITY CLASS. (of this report) UNCLASSIFIED
		15a. DECLASSIFICATION/DOWNGRADING SCHEDULE
16. DISTRIBUTION STATEMENT (of this Report) Distribution limited to US Government agencies and contractors directly involved in the HITVAL Program because the report contains data and information concerning a Joint Operational Test and Evaluation Program involving Soviet anti-aircraft weapons (May 75). Other requests for this document must be referred to ODDR&E (T&E), Wash, DC, 20301.		
17. DISTRIBUTION STATEMENT (of the abstract entered in Block 20, if different from Report)		
18. SUPPLEMENTARY NOTES		
19. KEY WORDS (Continue on reverse side if necessary and identify by block number) HITVAL mathematical attrition models; Soviet anti-aircraft guns; FRG 5PFZ-B Flakpanzer; Break-up ammunition; S-60 systems; ZU-23-2; Anti-aircraft gun instrumentation; attrition model empirical data		
20. ABSTRACT (Continue on reverse side if necessary and identify by block number) HITVAL is a joint Army/Air Force test program to acquire an empirical data base to determine hit probability of selected Soviet anti-aircraft guns against US fixed and rotary wing aircraft. The data base will be used to determine the degree of validity of three DOD aircraft attrition models. A preliminary system scoring test was conducted to determine the accuracy of the gun instrumentation mounted on an S-60 gun, the 23-mm twin-barrel gun, and the XM-42A weapon system. The gun instrumentation system measured the azimuth and elevation of the gun		

DD FORM 1 JAN 73 1473

EDITION OF 1 NOV 65 IS OBSOLETE

UNCLASSIFIED

SECURITY CLASSIFICATION OF THIS PAGE (When Data Entered)

UNCLASSIFIED

SECURITY CLASSIFICATION OF THIS PAGE(When Data Entered)

breech relative to the gun base, the tilt of the gun base and tracking errors of the gun crew. The target position was measured by cinetheodolites. A comparison of the cinetheodolite and gun instrumentation position information was performed to quantify the errors in gun instrumentation systems and thus determine the accuracy of the hit scoring system.

UNCLASSIFIED

SECURITY CLASSIFICATION OF THIS PAGE(When Data Entered)

PREFACE

The requirement for this report was established by the Director, Defense Research and Engineering, Test and Evaluation (DDR&E/T&E) and the Weapon System Evaluation Group/Institute for Defense Analysis. This report documents the results of the static and dynamic system scoring tests. It also contains the necessary data to identify the accuracy levels achieved by the gun instrumentation system mounted on the S-60 gun, ZU-23, and the XM-42A. This report should be of interest to the Department of Defense planners as well as analysts and instrumentation personnel concerned with the instrumentation and testing of anti-aircraft gun systems.

Acknowledgment is given to James Sweeney and Major John W. Ulmer, Jr., of the Air Force Special Weapons Center for their work in the data gathering, analysis, and preparation of the system scoring test report.

Acknowledgment is also given to Charles N. Alston and Michael R. Chernick of the US Army Material Systems Analysis Activity for their analytical support and especially for the analysis of variance and related material contained in appendix 4.

CONTENTS

<u>Section</u>		<u>Page</u>
I	INTRODUCTION	11
II	STATIC TESTS	17
	Methodology	17
	Data Error Summaries	17
	Analysis	23
III	DYNAMIC TESTS	24
	Test Requirements	24
	Data Acquired	24
	Data Summaries	39
	Analysis	47
	Problems and Limitations Encountered	55
	REFERENCES	61
	APPENDIXES	
	1. Description of Test Equipment	63
	2. Test Approach and Procedures	78
	3. Data Processing	101
	4. Mathematical Reviews, Calculations, and Analysis	115
	DISTRIBUTION	133

ILLUSTRATIONS

<u>Figure</u>		<u>Page</u>
III-1	Minimum Flight Paths for the Dynamic Scoring System Test	26
III-2	Data Collection Areas (S-60 Gun)	28
1-1	Elevation Optical Encoder on S-60 Gun	71
1-2	Typical Resolver on S-60 Gun	71
1-3	Pressure Transducer (S-60 Gun)	72
1-4	Drawing of Tilt Measurement System	72
1-5	Optical Mounted Autocollimators	73
1-6	LOCAM Mounted on S-60 Gun	73
1-7	Muzzle Deflection System Diagram	74
1-8	Gun Interface Unit (GIU)	74
1-9	Computer Interface Unit (CIU)	75
1-10	Hewlett Packard HP-2100A Computer (center cabinet)	75
1-11	ASR-33 Teletype Unit	76
1-12	Recording and Processing Van	76
1-13	HITVAL Instrumentation Van (Recording and Processing Van)	77
2-1	Surveyed Targets and Gun Positions	94
2-2	Angles Measured on the Gun System ZU-23	95
2-3	Physical Measurements on the ZU-23 Gun System	96
2-4	Physical Measurements on the S-60 Gun	97
2-5	Breech and Tracking Sight Pointing Errors	98
2-6	Sample Computer Printout of the Static Engineering Unit Program	99
2-7	Alignment Concept	100
2-8	Test Site Communications	100

ILLUSTRATIONS (cont'd)

<u>Figure</u>		<u>Page</u>
3-1	WSMR Tracking Data Format	112
3-2	WSMR Header Data Format	113
3-3	Data Flow Chart	114
4-1	Azimuth Measurement Error versus Azimuth	131
4-2	Transformation from Tilted to Untilted	132

TABLES

<u>Table</u>		<u>Page</u>
I-1	Accuracy Requirements of Hit Scoring System	13
I-2	Total Combined Error of Hit Scoring System (Using Aircraft Positional Error of 1.5 meters)	14
I-3	Error Data Summary (Dynamic Scoring System Test)	15
II-1	Summary of Static Scoring System Results (Breech Pointing Angle Errors)	18
II-2	Summary of Breech and Tracking Sight Point Errors (ZU-23)	19
II-3	Summary of Breech and Tracking Sight Point Errors (S-60 Gun)	20
II-4	Summary of Breech Pointing Angle Errors (XM-42A)	21
II-5	Summary of Error Dispersion (Breech Pointing Angle Errors)	22
II-6	Static Scoring System Test Results (Tracking Sight Pointing Errors)	22
III-1	Minimum Trials for HITVAL I	25
III-2	Minimum Trials for HITVAL II	25
III-3	Summary of Trials	29
III-4	HITVAL I Statistical Summary	38
III-5	HITVAL II Statistical Summary	41
III-6	Dynamic Scoring System Test Results	44
III-7	Raw Position Precision	46
III-8	Smoothing Residuals for Cinetheodolite Positions	46
III-9	Error Data (Azimuth)	48
III-10	Error Data (Elevation)	51
2-1	Target and Gun Positions in the Reference Coordinate System	79
2-2	Resolution of Angle Measurement Transducers (ZU-23)	86

TABLES (cont'd)

<u>Table</u>		<u>Page</u>
2-3	Fire Control Input Errors (ZU-23)	87
2-4	Fire Control Inputs and Reflex Sight Errors Relative to Target (ZU-23)	89
2-5	Fire Control Inputs and Reflex Sight Errors Relative to Target (S-60 Gun)	89
3-1	Data Elements, ZU-23	104
3-2	Data Elements, S-60	105
3-3	Data Elements, HITVAL II Gun System	106
3-4	Tabular Output	111
4-1	Breech Azimuth	119
4-2	Analysis of Variance	119
4-3	Breech Elevation	120
4-4	Analysis of Variance	120
4-5	Resolution of Angle Measurement Transducers	123
4-6	Assumed Actual Angles	124
4-7	Resolution Distribution Summary	125

ABBREVIATIONS AND SYMBOLS

AZ	azimuth
AFWL	Air Force Weapons Laboratory
AGL	above ground level
Analog-to-Digital Converters (A-D Converters)	electrical device that converts electrical analog signals to electrical digital signals; see Encoder (optical)
A-4	US Navy Tactical Fighter
BCD	binary coded decimal
BPI	bits per inch
BVT	ballistic verification test
BIT	computer term that denotes 1 or 0 on tape or computer logic
CDC	Control Data Corporation
Cinetheodolites	photo-optical tracking instrumentation that provides target position as a function of IRIG time
CIU	computer interface unit
CRT	cathode ray tube
DCO	data coordinator officer
DCU	data communication unit
DDR&E (T&E)	Director of Defense Research and Engineering (Test and Evaluation)
EG&G	Egerton, Germishausen, and Grier, prime contractor for development and maintenance of instrumentation on the gun systems and collection of field test data
FPS-16	fixed position radar to determine target position as a function of IRIG time
GIU	gun interface unit
HeNe	helium neon, gases used in laser system
HITVAL	code name for joint test to determine probability of hit by anti-aircraft guns against low-flying fixed and rotary wing aircraft

ABBREVIATIONS AND SYMBOLS (cont'd)

HITVAL I	joint test involving the ZU-23-2, S-60 gun, S-60 system, and 5PFZ-B antiaircraft guns
HITVAL II	joint test involving the XM-42A antiaircraft gun
HP-2100A	Hewlett Packard computer
IDA	Institute for Defense Analysis
IPS	inches per second
IRIG	Interrange Instrumentation Group
JTD	Joint Test Director
JTF	Joint Test Force
LOCAM	motion picture camera
MPS-36	mobile radar to determine target position as a function of IRIG time
RCS	reference coordinate system
R&P van	recording and processing van
TAU-56B	flares mounted on TDU-25B for acquisition of target
TDU-25B	tow target
TOF	time of fire
TSPI	time, space, position information
SST	system scoring test
S-60	Soviet single 57-mm towed antiaircraft gun
WSEG	Weapons Systems Evaluation Group
WSMR	White Sands Missile Range
XM-42A	experimental antiaircraft system
ZU-23	Soviet 23-mm towed antiaircraft gun
5PFZ-B	Federal Republic of Germany twin 35-mm self-propelled anti-aircraft gun

ABBREVIATIONS AND SYMBOLS (cont'd)

θ azimuth, subscripts denote base

ϕ, ϕ elevation, subscripts denote base

SECTION I
INTRODUCTION

1. BACKGROUND

HITVAL is an acronym for the DOD-directed Army/Air Force Joint Test to determine the hit probability of selected foreign antiaircraft guns firing break-up ammunition at maneuvering fixed and rotary wing US aircraft. The objective of the program was to provide a data base to evaluate and/or modify selected DOD aircraft attrition models. Director, Defense Research and Engineering, Test and Evaluation (DDR&E/T&E) directed the program, the Army Materiel Command acted as the executive agent, and the Air Force Systems Command (AFSC) provided the Air Force Deputy Test Director.

The test equipment in HITVAL I consisted of four thoroughly instrumented gun systems: Russian ZU-23 (twin 23-mm optical sight), Russian S-60 gun (57-mm optical sight), Russian S-60 system (57-mm with SON-9 radar and PUAZO fire director), and a Federal Republic of Germany FPZ-5 (twin 35-mm track-mounted tank). The HITVAL II test utilized the XM-42A weapon system. The aircraft to be engaged by the guns were Air Force F-4s and A-37s (simulating A-10s) and Army AH-1G and OH-58 aircraft. The weapons systems were instrumented to measure very precisely the azimuth and elevation pointing angles of the gun breech, fire director, and radars. Gun sights and fire-control inputs were also accurately measured. Ballistic trajectories of lethal ammunition are to be projected by computer and compared with aircraft position to determine hit probability.

The requirement for preliminary tests to demonstrate the accuracy of the gun instrumentation system is contained in reference 1. The preliminary tests consisted of a tilt test, system scoring test (SST), and a ballistic verification test. This report documents the results of both the static and dynamic SSTs for HITVAL I and HITVAL II. The HITVAL I SSTs were conducted at White Sands Missile Range (WSMR) from October 1973 to March 1974. For HITVAL II the SSTs were performed during November 1974 at WSMR.

2. OBJECTIVE AND SCOPE

The objective of the system scoring tests was to determine the accuracy of the gun instrumentation system to be used in the field test. The total combined error budget of the instrumentation systems, as specified in reference 2, was 0.8 milliradians. Possible instrumentation errors consist of the following: errors of the target tracking system; survey errors of the tracking system relative to the gun; and gun barrel pointing angle errors, including gun tilt. These include azimuth, elevation, and range errors.

The instrumentation system scoring test was a comprehensive test composed of two basic parts, a static test and a dynamic test. Static scoring system tests were conducted and analyzed by the instrumentation contractor, EG&G. The contractor compared fixed target positions as determined by gun pointing angles with the surveyed position of the targets. The static tests are discussed in section II of this report.

The dynamic scoring system test was conducted as follows:

a. The ZU-23, S-60 gun (optical), and the XM-42A guns tracked a TDU-25B tow target or aircraft at approximately 300 knots TAS.

b. WSMR FPS-16/MPS-36 radar and cinetheodolites provided accurate target position.

c. The target position measured by the pointing angles of the guns was compared with the target position measured by the cinetheodolites to determine the errors of the gun pointing instrumentation system.

d. The tracking errors of the gun crews were obtained by a camera mounted on the gun breech.

e. The tests included trials at from 0.5- to 3-km range, elevations of from 5 to 70 degrees, and azimuth angles of from 0 to 360 degrees.

f. Both firing and nonfiring trials were conducted during HITVAL I against the tow target. Only nonfiring trials were conducted in HITVAL II. Service ammunition was used in the firing trials to determine the firing effects on angle measurements.

The error budget for the tests is shown in table I-1. The recommended total combined error budget was 0.8 mrad. This was obtained by the root sum square of the individual specified accuracies. The stated aircraft positional

Table I-1
ACCURACY REQUIREMENTS OF HIT SCORING SYSTEM*

<u>Errors</u>	<u>Azimuth elevation (mrad)</u>	<u>Range (meters)</u>
Aircraft positional error as measured by tracker	0.2	2
Surveyed positional error of laser tracker relative to gun (based on survey accuracy of 1/25,000)	0.04	0.2
Angular error of tracker relative to reference direction	0.1	---
Pointing angle errors of gun barrel including gun-mount tilt	0.7	---
Angular error of gun mount relative to reference direction	0.1	---
Total combined error of instrumentation system	0.8	2

*Source: WSEG/IDA Report 197.

error budget of 0.2 mrad angular error and 2 meters range was based on precision capability of a Laser Tracking System (LTS). However, technical difficulties prevented the LTS from becoming fully operational, and cinetheodolites were used as the primary source of TSPI data for targets. WSMR quoted the positional precision of the cinetheodolite system as ± 1.5 meters and no angular position was provided. Table I-2 presents the total combined error budget of the instrumentation system for 1-km intervals by substituting the quoted precision of ± 1.5 meters for aircraft position error. At slant ranges from the gun out to 4.0 km, this uncertainty in aircraft position will result in a combined hit scoring system error budget greater than 0.80 mrad. The total combined error budget of the instrumentation system of 0.8 mrad is applicable as presented in table I-1 only with the LTS. Since the LTS was not utilized and the cinetheodolites were the primary TSPI data source, the error budget should be a sliding scale as presented in table I-2 and larger than the specified 0.8 mrad within 4.0 km of the guns.

Table I-2

TOTAL COMBINED ERROR BUDGET OF HIT SCORING SYSTEM
(USING AIRCRAFT POSITIONAL ERROR OF 1.5 METERS)

Target to gun slant range <u>(km)</u>	Combined error budgets (using cinetheodolites) (mrad)
1	1.66
2	1.03
3	0.87
4	0.80
5	0.77

3. SUMMARY OF ANALYSIS

The results of the static scoring system tests of the ZU-23, S-60 gun, and XM-42A reveal that the accuracy of the breech pointing measurement system is within the required accuracy of 0.8 mrad. Since the instrumentation contractor was responsible for the static tests, the detailed test results are contained in references 3, 4, and 5.

A summary of the results of the dynamic scoring system tests, for all three guns, is presented in table I-3. The errors are grouped into intervals centered at zero, with percentages under the number of data points to assist the reader in making comparisons. The data are presented in the following manner:

- a. Azimuth errors for each gun
- b. Elevation errors for each gun
- c. Combined azimuth and elevation errors for each gun
- d. Total azimuth and elevation errors for all three guns

Table I-3 shows that of 21,954 data points collected in both elevation and azimuth, 6412 data samples were from the ZU-23, 5872 were from the S-60 gun, and 9670 were from the XM-42A weapon system. WSEG/IDA has indicated that the total combined error budget of 0.8 mrad pertains to one standard deviation (68 percent). If the assumption of normality is made, then one can see from table I-3 that azimuth errors for the ZU-23 at 69.6 percent, elevation errors

Table I-3
 ERROR DATA SUMMARY (DYNAMIC SCORING SYSTEM TEST)

Summary condition	Total data points	Number of data points in each data interval and percentage									
		<u>±0.2</u>	<u>±0.6</u>	<u>±0.8</u>	<u>±1.0</u>	milliradians		<u>±2.2</u>	<u>±2.6</u>	<u>±3.0</u>	<u>±5.0</u>
Azimuth (ZU-23)	3,206	834 26.0%	1721 53.7%	2232 69.6%	2564 80.0%	2930 91.4%	3018 94.1%	3085 96.2%	3152 98.3%	3189 99.5%	3199 99.8%
Elevation (ZU-23)	3,206	547 17.1%	1305 40.7%	1591 49.6%	1954 61.0%	2551 79.6%	2974 92.8%	3144 98.1%	3173 99.0%	3184 99.3%	3200 99.8%
Azimuth (S-60)	2,936	265 9.0%	879 29.9%	1293 44.0%	1745 59.4%	2350 80.0%	2737 93.2%	2893 98.5%	2932 99.9%	2933 99.9%	2934 99.9%
Elevation (S-60)	2,936	1077 36.7%	2198 74.9%	2537 86.4%	2746 93.5%	2916 99.3%	2929 99.8%	2929 99.8%	2931 99.8%	2931 99.8%	2935 99.9%
Azimuth (XM-42A)	4,835	1002 20.7%	2420 50.1%	3132 64.8%	3755 77.7%	4307 89.1%	4619 95.5%	4763 98.5%	4794 99.2%	4803 99.3%	4817 99.6%
Elevation (XM-42A)	4,835	2533 52.4%	4061 84.0%	4352 90.0%	4639 95.9%	4740 98.0%	4771 98.7%	4730 98.9%	4784 98.9%	4785 99.0%	4800 99.3%
Azimuth (all 3 guns)	10,977	2101 19.1%	5020 45.7%	6657 60.6%	8064 73.5%	9587 87.3%	10374 94.5%	10741 97.9%	10878 99.1%	10925 99.5%	10950 99.8%
Elevation (all 3 guns)	10,977	4157 37.9%	7564 68.9%	8480 77.3%	9339 85.1%	10207 93.0%	10674 97.2%	10853 98.9%	10888 99.2%	10900 99.3%	10935 99.6%
Az and E1 (ZU-23)	6,412	1381 21.5%	3026 47.2%	3823 59.6%	4518 70.5%	5481 85.5%	5992 93.5%	6229 97.2%	6325 98.6%	6373 99.4%	6399 99.8%
Az and E1 (S-60)	5,872	1342 22.9%	3077 52.4%	3830 65.2%	4491 76.5%	5266 89.7%	5666 96.5%	5822 99.2%	5863 99.8%	5864 99.8%	5869 99.9%
Az and E1 (XM-42A)	9,670	3535 36.6%	6481 67.0%	7484 77.4%	8394 86.8%	9047 93.6%	9390 97.1%	9543 98.7%	9578 99.0%	9588 99.2%	9617 99.5%
Total Az & E1 (all 3 guns)	21,954	6258 28.5%	12584 57.3%	15137 68.9%	17403 79.3%	19794 90.2%	21048 95.9%	21594 98.4%	21766 99.1%	21825 99.4%	21885 99.7%

for the S-60 gun at 86.4 percent, elevation errors for the XM-42A at 90.0 percent, elevation errors for all three guns at 77.3 percent, azimuth and elevation errors for the XM-42A at 77.4 percent, and the combined azimuth and elevation errors for all three guns at 68.9 percent are within the specified error budget. The data also indicate that the XM-42A gun instrumentation system demonstrated better performance with 77.4 percent of the combined azimuth and elevation data points falling within ± 0.3 mrad, in contrast to the S-60 gun and ZU-23 where the percentages were 65.2 and 59.6 percent, respectively. The XM-42A and S-60 instrumentation systems were more accurate in elevation and the ZU-23 was more accurate in azimuth.

SECTION II

STATIC TESTS

1. METHODOLOGY

The methodology and test procedures used by EG&G to verify the accuracy of the gun instrumentation system is contained in references 3, 4, and 5 for the ZU-23, S-60 gun, and XM-42A, respectively. An extensive discussion of the test approach and procedures are contained in appendix 2, paragraph A. The HITVAL I tests were accomplished on the twin 23-mm and the 57-mm on-carriage systems, and the XM-42A system was used for HITVAL II. Differences in procedures between HITVAL I and HITVAL II will be identified in appendix 2. In general, the two static tests were handled identically.

All gun encoders/resolvers were calibrated and aligned using the procedures identified in appendix 2, paragraph A.2. The static gun pointing angles were determined by the breech azimuth and elevation encoders which measured the breech pointing angles relative to the gun base, and by the autocollimators, which measured the roll, pitch, and yaw angles of the base relative to the ground. The breech was pointed at six surveyed targets, positioned in a circle of approximately 2-km radius. A 5-power rifle telescope attached to the gunner's quad plate and aligned parallel to the muzzle bore was used to lay the breech "on target." The vector from the gun position to the target was rotated and translated to the alignment scope's position on the tilted gun frame by using the measured roll, pitch, and yaw angles and the physical dimensions of the gun. The azimuth and elevation angles between the alignment scope on the tilted gun frame and the surveyed targets were computed and compared to the encoder-measured azimuth and elevation angles. Thus, the errors in azimuth and elevation of the "gun-pointing measurement system" were determined.

2. DATA ERROR SUMMARIES

Table II-1 shows the means and standard deviations of the breech azimuth and elevation errors for the three gun systems used in HITVAL I and HITVAL II. The results of the static tests reveal that means and standard deviations of the

Table II-1

SUMMARY OF STATIC SCORING SYSTEM TEST RESULTS
(BREECH POINTING ANGLE ERRORS) (mrad)

	<u>ZU-23 (Gun 1)</u>		<u>S-60 (Gun 2)</u>		<u>XM-42A (Gun 5)</u>	
	<u>AZ</u>	<u>EL</u>	<u>AZ</u>	<u>EL</u>	<u>AZ</u>	<u>EL</u>
Mean	0.05	0.02	-0.04	0.14	0.04	0.07
Standard deviation	0.29	0.60	0.44	0.59	0.40	0.34
Number of trials	36		36		36	

breech alignment errors for the three guns are within the WSEG/IDA specified ± 0.8 mrad accuracy requirements. A tabulation of the breech and tracking sight pointing errors for the ZU-23, S-60 gun, and XM-42A gun are presented in tables II-2 through II-4.

The mean error provides an estimate of the alignment of the gun instrumentation to the reference coordinate system (RCS). The mean errors shown in table II-1 were all less than 0.1 mrad, except for the elevation error on the S-60 gun, which was 0.14 mrad. The breech elevation static scoring measurement on Gun 5 shows better repeatability than the breech elevation measurements on Guns 1 and 2. The standard deviation of the breech elevation error on Gun 5 was 0.34 mrad, while on Guns 1 and 2 it was 0.6 mrad. It is believed that the elevation error on Gun 5 was more repeatable because of a more stable (electro-optical) tilt system used on that gun. Gun 1 showed better repeatability in azimuth than Guns 2 and 5. The reason is unknown.

If the assumption is made that the total population of errors are normally distributed, then we can estimate the dispersion of errors in azimuth and elevation at the 68 percent (± 1 standard deviation) and 95 percent (± 2 standard deviations) levels for the three guns as shown in table II-5. Under the assumption of normality, 68 percent of the data in both azimuth and elevation, for all three guns, are within the required accuracy of ± 0.8 mrad. At the 95 percent level, azimuth for the ZU-23 and both azimuth and elevation for the XM-42A are within the required accuracy. This indicates that the precision of the XM-42A gun pointing angle measurement system is superior to the S-60 gun, in both azimuth and elevation, and better than the ZU-23 in elevation. The variance is more pronounced in elevation for both the ZU-23 and S-60 gun; however, in the case of the XM-42A the variance is greater in azimuth.

Table II-2

SUMMARY OF BREECH AND TRACKING SIGHT POINT ERRORS (ZU-23)
(milliradians)

<u>Target</u>	<u>Roll</u>	<u>Pitch</u>	<u>Breech azimuth</u>	<u>Breech elevation</u>
1	1.01	1.30	0.05	0.50
2	0.68	1.30	0.20	0.58
3	0.68	0.97	0.71	0.14
4	1.01	0.64	-0.03	0.19
5	1.34	0.97	0.40	-0.41
7	1.68	0.97	0.57	-0.45
7	1.95	0.72	-0.09	-0.37
5	1.60	0.71	0.11	0.08
4	0.94	0.37	-0.31	0.69
3	0.94	0.71	0.43	-0.02
2	0.94	1.04	-0.09	0.51
1	1.60	1.04	0.01	0.67
1	13.06	11.69	0.22	1.07
2	13.40	11.69	-0.03	-0.91
3	12.73	11.36	0.23	-1.36
4	13.06	11.02	-0.27	-1.15
5	13.40	11.02	-0.03	-0.26
7	14.06	11.69	0.31	0.73
7	12.74	10.83	0.30	-0.34
5	12.74	10.49	-0.02	-0.17
4	12.08	10.61	-0.31	0.11
3	12.08	10.49	0.56	-0.19
2	12.41	10.83	-0.41	0.15
1	12.41	10.83	-0.56	0.81
1	-7.59	-8.36	-0.09	0.15
2	-7.92	-8.36	0.12	-0.80
3	-7.92	-8.36	0.25	-0.62
4	-6.92	-8.69	-0.10	-0.66
5	-7.25	-8.69	-0.27	0.59
7	-7.25	-8.36	-0.21	-0.37
7	-8.21	-8.27	0.29	-0.71
5	-8.21	-8.61	0.23	0.19
4	-7.87	-8.61	-0.31	0.54
3	-8.87	-8.61	0.03	0.74
2	-8.87	-8.27	-0.10	0.46
1	-8.54	-8.27	0.01	0.48
Mean error			0.05	0.02
Standard deviation			0.29	0.60

Table II-3

SUMMARY OF BREECH AND TRACKING SIGHT POINT ERRORS (S-60 GUN)
(milliradians)

<u>Target</u>	<u>Roll</u>	<u>Pitch</u>	<u>Breech azimuth</u>	<u>Breech elevation</u>
1	0.39	0.31	-0.27	0.70
2	-0.27	-0.02	0.45	0.29
3	-0.61	-0.02	0.16	0.53
4	0.39	-0.02	-0.40	0.07
5	0.39	-0.36	-0.09	0.86
7	0.06	-0.02	0.08	-0.69
5	0.24	0.14	-0.29	-0.02
4	0.09	0.14	-0.58	-0.26
3	-1.09	0.14	-0.03	0.53
2	-1.09	0.14	0.26	1.06
1	-0.09	0.48	-0.46	0.75
7	-0.42	0.14	-0.17	-1.06
1	9.53	9.35	-0.53	-0.09
2	9.30	9.35	0.35	0.52
3	8.97	9.35	0.20	0.94
4	9.30	9.02	-0.43	1.24
5	9.97	9.02	0.54	0.53
7	9.64	9.35	0.42	-0.65
5	10.34	9.70	0.29	0.03
4	9.67	9.70	-0.68	-0.23
3	9.34	10.03	-0.03	-0.28
2	9.67	10.03	0.21	0.15
1	9.67	10.03	-0.77	0.67
7	10.01	10.03	0.17	-0.29
1	-12.21	-12.54	-0.60	-0.31
2	-12.88	-12.54	0.23	0.54
3	-12.88	-12.88	0.31	0.67
4	-12.88	-12.88	-0.58	1.11
5	-12.21	-12.88	-0.15	8.09
7	-11.51	-12.51	0.63	-0.46
5	-11.54	-12.31	-0.18	-0.08
4	-11.54	-12.31	-0.62	-0.33
3	-12.20	-12.31	0.28	-0.79
2	-11.45	-12.10	0.21	-0.86
1	-11.54	-11.98	-0.62	0.07
7	-10.87	-11.98	0.60	0.12
Mean error			-0.0383	0.1408
Standard deviation			0.4353	0.5942

Table II-4

SUMMARY OF BREECH POINTING ANGLE ERRORS (XM-42A)
(milliradians)

<u>Target</u>	<u>Roll</u>	<u>Pitch</u>	<u>Yaw</u>	<u>Breech azimuth error</u>	<u>Breech elevation error</u>
71	6.90	7.23	0.00	-0.46	0.07
24	6.87	6.82	0.00	-0.19	-0.15
41	7.69	6.41	-0.32	-0.09	-0.13
52	8.10	6.41	-0.33	0.25	-0.13
5	8.10	6.82	0.00	-0.15	0.24
6	7.69	7.23	-0.33	-0.23	-0.02
6	7.72	7.46	-0.33	-0.01	-0.27
5	8.13	7.05	-0.67	0.74	0.03
52	8.13	6.64	0.00	0.16	0.20
41	7.72	6.64	-0.33	0.14	-0.02
24	6.90	6.64	-0.33	-0.02	-0.29
71	6.90	7.05	0.00	0.15	-0.27
71	-4.40	-4.79	-0.01	0.17	0.68
24	-3.99	-5.61	-0.16	0.32	-0.16
41	-2.76	-6.43	-0.67	0.93	-0.55
52	0.08	-5.17	-0.33	0.64	-0.43
5	1.34	-3.15	-0.44	0.62	0.10
6	1.34	-2.74	-0.33	0.59	0.77
6	0.48	-1.09	0.67	-0.27	0.32
5	1.30	-1.50	0.67	-0.15	0.07
52	1.71	-1.50	0.87	-0.38	0.17
41	1.30	-1.91	1.00	-0.78	0.16
24	0.48	-1.91	0.67	-0.55	-0.08
71	1.30	-1.50	0.67	-0.47	0.34
71	-2.40	0.30	0.67	0.16	0.45
24	-1.99	-0.52	0.33	0.57	0.71
41	-0.76	-0.93	0.08	0.58	-0.44
52	0.89	-0.52	0.67	0.32	0.45
5	1.70	0.30	0.67	-0.08	-0.15
6	1.70	0.71	0.67	-0.03	-0.10
6	1.12	0.60	0.67	-0.27	-0.06
5	1.12	0.60	0.68	-0.33	-0.10
52	1.12	0.19	0.68	0.12	0.86
41	1.79	0.04	0.67	-0.24	0.08
24	0.71	-0.22	0.67	-0.37	-0.04
71	1.10	0.58	0.67	-0.11	0.13
Mean error				0.036	0.067
Standard deviation				0.403	0.337

Table II-5

SUMMARY OF ERROR DISPERSION
(BREECH POINTING ANGLE ERRORS) (mrad)

	<u>68 percent of errors</u>		<u>95 percent of errors</u>	
	<u>AZ</u>	<u>EL</u>	<u>AZ</u>	<u>EL</u>
ZU-23	0.34 to -0.24	0.60 to -0.58	0.63 to -0.53	1.22 to -1.18
S-60 gun	0.40 to -0.48	0.73 to -0.45	0.84 to -0.92	1.32 to -1.04
XM-42A	0.44 to -0.36	0.41 to -0.27	0.84 to -0.76	0.75 to -0.61

The tracking sight pointing errors for the ZU-23 and S-60 gun are summarized in tables 2-4 and 2-5 in appendix 2. The tracking sight pointing errors were tested with the fire control system zeroed. The mean errors and standard deviation in sight azimuth and elevation, for Guns 1, 2, and 5, are shown in table II-6. The standard deviation for both Guns 1 and 2 showed a large variance from a maximum of 1.92 mrad to a minimum of 0.92 mrad. However, the sight pointing errors are not believed to be as critical as the breech pointing errors and a greater deviation of errors can be accepted. The tracking sight was further tested by inputting conditions into the fire control system that provided maximum lead angles between the tracking sight and the breech, by laying the tracking sight on target, and by computing the azimuth and elevation errors of the sight. Eight lead angle conditions representing 45° intervals around the field of view of the tracking sight were examined. The sight pointing angle test data showed a large error due to improper alignment of the sight mechanism. A special fixture, designed to adapt an inclinometer to the traverse lead axis (pin) of the reflex sight was used to check the alignment of the sight mechanism.

Table II-6

STATIC SCORING SYSTEM TEST RESULTS
(TRACKING SIGHT POINTING ERRORS) (mrad)

	<u>ZU-23 (Gun 1)</u>		<u>S-60 (Gun 2)</u>		<u>XM-42A (Gun 5)</u>	
	<u>AZ</u>	<u>EL</u>	<u>AZ</u>	<u>EL</u>	<u>AZ</u>	<u>EL</u>
Mean	-0.56	-0.49	0.14	0.95	0.01	-0.05
Standard deviation	1.43	1.20	0.92	1.92	0.45	0.45

3. ANALYSIS

The instrumentation contractor concluded in references 3, 4, and 5 that the accuracy of the breech pointing measurement system, for all three guns, is well within the required accuracy of 0.8 mrad. The inputs dialed into the fire control system were verified and found to be within the specified requirements. In addition, the tracking sight pointing errors were tested for large lead angles, and found to be within tolerance.

The HITVAL staff performed an independent analysis and evaluation of the breech azimuth and elevation measurement error data, from the static scoring system test of the ZU-23 gun system. The analytical techniques and the results are contained in appendix 4, paragraph A. The identical methodology could be applied to either the S-60 gun or XM-42A static scoring system test data. The primary objective of the independent analysis was to determine if there were any statistically significant variations between the six targets used and the tilt system. The results of the analysis indicate that

- a. There is no significant correlation between breech azimuth and breech elevation measurement errors; therefore, each was studied separately.
- b. The largest measurement errors occurred for targets numbered 3, 4, and 7. The bias was positive for targets numbered 3 and 7 and negative for target number 4.
- c. Breech azimuth errors attributable to both targets and tilt (roll and pitch) were statistically significant. The interaction component of variance is not statistically significant and is estimated to be negligible.
- d. Breech elevation errors attributable to both targets and tilt were not statistically significant.
- e. Determination of compliance with WSEG/IDA accuracy requirements is not as meaningful in a static test environment where measurements are made under carefully controlled conditions, in contrast to a dynamic test environment where measurements are made under typical field test conditions.

SECTION III

DYNAMIC TESTS

1. TEST REQUIREMENTS

The specific test requirements are contained in reference 1. An extensive discussion of the test approach and procedures are contained in appendix 2, paragraph B. The minimum dynamic system scoring test requirements consisted of eight trials for each of the three guns: six nonfiring and two firing for the ZU-23 and S-60 guns, and all eight nonfiring for the XM-42A gun. The minimum trials required are listed in table III-1 for HITVAL I and in table III-2 for HITVAL II. Typical flight paths in relation to the gun site are illustrated in figure III-1. The order of trials or passes were varied on the basis of lighting conditions for the cinetheodolites, visibility for the pilot or gun crew, interference with other field tests, or safety.

HITVAL I utilized a TDU-25 tow target which carried only four flares; each mission was limited to four trials. The test for HITVAL I should have required only two missions; however, WSMR requirements dictated that trials in the diagonal direction (122° to 302°) not be mixed with trials in 180° to 360° direction. Since six trials during HITVAL I must be conducted on the 122° to 302° tracks and firing trials must be conducted on these same tracks, a total of two missions (eight trials) were required for both the firing and nonfiring mode. The 180° to 360° tracks then required an additional mission of four trials in the 180° to 360° direction.

HITVAL II utilized an F-4 aircraft as the target with all data reduced to the nose of the aircraft. A total of two missions were required to meet the minimum requirements contained in table III-2.

2. DATA ACQUIRED

Over 100 trials were conducted during HITVAL I and 21 trials during HITVAL II in an effort to determine the dynamic accuracy of the gun instrumentation system. Of these, useable data were collected on 19 trials on the ZU-23, 14 trials on the S-60 gun, and 16 trials on the XM-42A. The following data had to be recorded for trials to be classified as useable:

Table III-1
MINIMUM TRIALS FOR HITVAL I

<u>Trial No.</u>	<u>Heading</u>	<u>Offset distance/direction</u>	<u>Altitude</u>	<u>Firing/nonfiring</u>
1	122	1 km/NE	Low	NF
2	122	2 km/NE	High	NF
3	302	1 km/NE	High	NF
4	302	2 km/NE	Low	NF
5	122	1 km/NE	High	F
6	302	1 km/NE	Low	F
7	360	2 km/E	High	NF
8	360	2 km/W	Low	NF

Table III-2
MINIMUM TRIALS FOR HITVAL II

<u>Trial No.</u>	<u>Heading</u>	<u>Offset distance/direction</u>	<u>Altitude</u>	<u>Firing nonfiring</u>
1	122	1 km/NE	Low	NF'
2	122	2 km/NE	High	NF
3	302	1 km/NE	High	NF
4	302	2 km/NE	Low	NF
5	180	1 km/E	Med	NF
6	180	1 km/W	Med	NF
7	360	2 km/E	Med	NF
8	360	2 km/W	Med	NF

(1000FT) LOW ALTITUDE
(5500FT) HIGH ALTITUDE

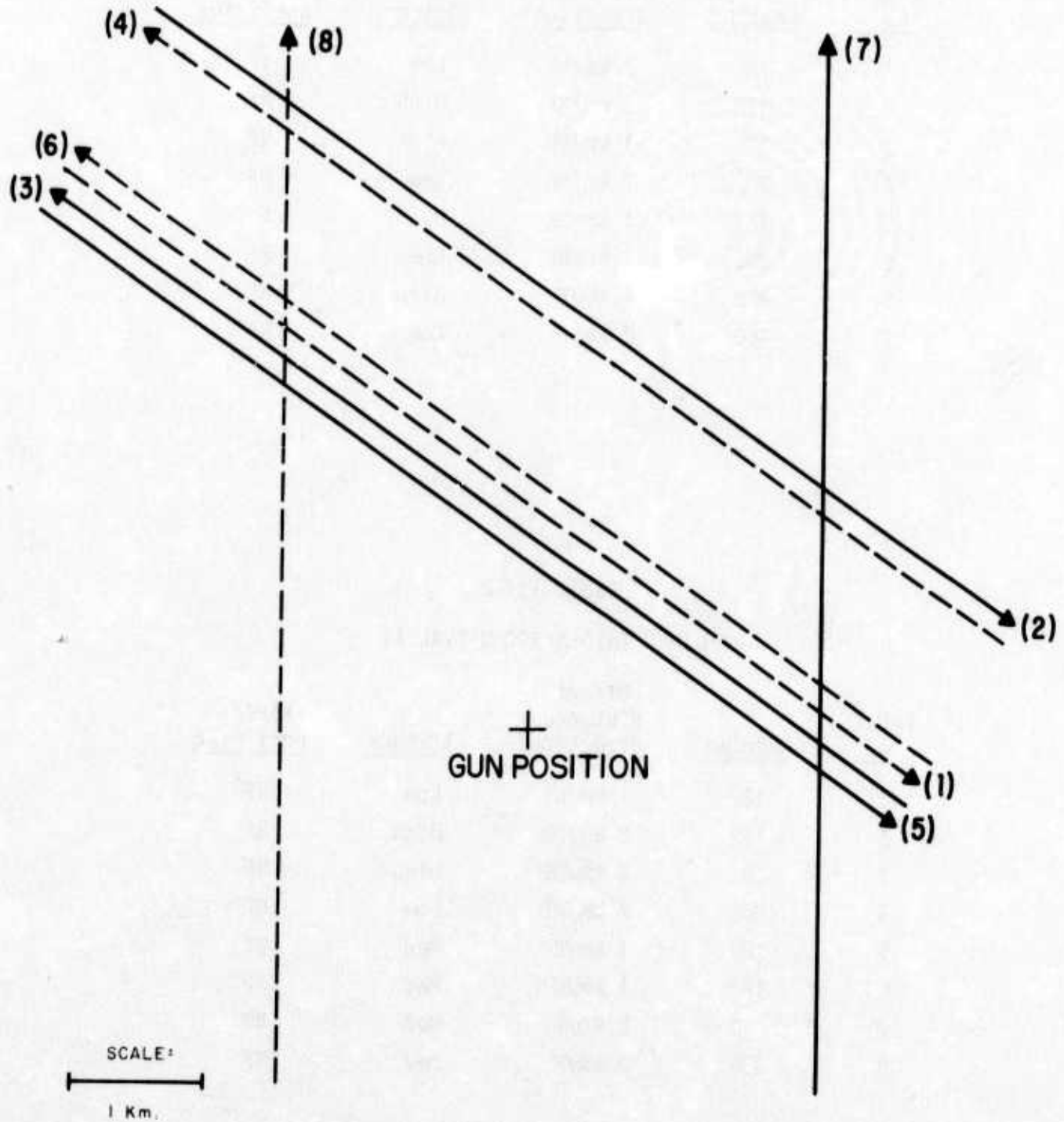

Figure III-1. Minimum Flight Paths for the Dynamic Scoring System Test

- a. Cinetheodolite tracking data of target position
- b. Recorded gun data tape
- c. Digitized camera data

Figure III-2 is a typical plot of tracks of each trial from which data were collected. Figure III-2 represents the actual data collection area for the dynamic SST on the S-60 gun. The tracks show the relationship of the gun system position to that of the target during the trial. An arrow next to each track line indicates the direction of travel of the target during a particular trial. Detailed data on specific trials are contained in subsequent tables and in annexes A, B, and C.

A comprehensive and detailed summary of all dynamic trials is contained in table III-3. This information was taken from the test conductor's logs, sortie test summaries, site controller's logs and mission debriefing sheets. The data items are identified by mission numbers (SST-No.) and trial numbers, and is the consolidation of all relevant test conditions. Table III-3 is a valuable reference on specific trials for both HITVAL I and HITVAL II, and the following is a brief explanation of each data element.

- a. Date. Date of mission at WSMR.
- b. Mission No. This is the identification of a particular range period. From two to eleven trials were accomplished on each mission. All missions are not consecutive as some missions were cancelled prior to flight and the mission number was not used.
- c. Trial No. The summary of trials is the master index of trial numbers and all trial data are coded to these numbers. Several trials have an "A" after the trial number; this was done on some of the earlier trials to designate a repeat of a run, but this procedure was later abolished as reruns became the rule rather than the exception.
- d. Gun type. This indicates the type gun system on each trial.
- e. Flare good. A trial with an operating flare is marked "Yes"; a trial with an inoperative flare is coded "No."
- f. Hdg. True heading of the tow aircraft as it tracked past the closest approach to the gun site.

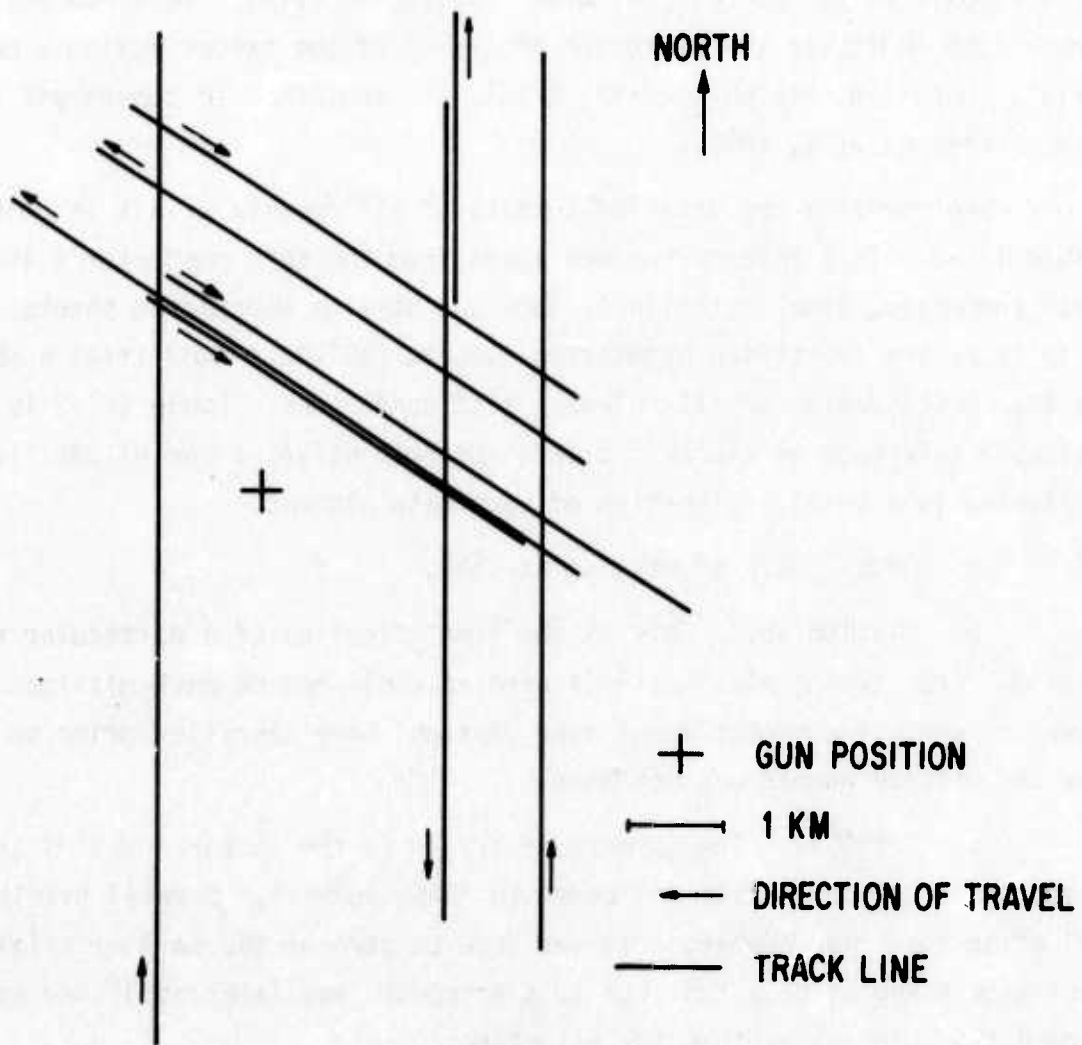

Figure III-2. Data Collection Areas (S-60 Gun)

Table III-3
SUMMARY OF TRIALS

Date	Mission No.	Trial	Gun type	Flare good	Hdg (deg)	Ht AGL	Offset (km)	Tgt	Cine data	Radar data	Track	Fire pedal	Gun data recorded	Mid-time trial	Remarks
150ct73	SST-2	1	23	No	180	2500	1 W	A-4	No	Yes	Yes	No	Yes	Not avail	Photo data to centroid of A-4
		2	23	No	180	1000	2 E	A-4	Yes	Yes	Yes	Yes	Yes	Not avail	
		3	23	No	360	2500	1 W	A-4	Yes	Yes	Yes	Yes	Yes	Not avail	
		4	23	No	360	3000	2 E	A-4	Yes	Yes	Yes	Yes	Yes	Not avail	
		5	23	No	180	2500	1 W	A-4	Yes	Yes	Yes	Yes	Yes	Not avail	
160ct73	SST-3	6	23	Yes	122	5000	2 NE	Tow	Yes	Yes	Yes	Yes	Yes	Not avail	
		7	23	Yes	122	1000	1 NE	Tow	Yes	Yes	Yes	Yes	Yes	Not avail	
		8	23	Yes	302	1000	1 NE	Tow	Yes	Yes	Yes	Yes	Yes	Not avail	
		9	23	No	302	1500	2 NE	Tow	Z	Yes	No	No	No	Not avail	
230ct73	SST 5 x 2	9A	23	No	302	1500	2 NE	Tow	Yes	No	Yes	No	Yes	Not avail	Tow/chase very close
		10	23	No	302	1000	3 NE	Tow	Yes	Yes	No	No	Invalid	Not avail	
		11	23	No	122	5500	2 NE	Tow	No	Yes	No	No	N/A	Not avail	
		11A	23	No	122	2000	1 NE	Tow	No	Yes	No	No	No	Not avail	
		12	23	No	302	5500	2 NE	Tow	No	Yes	No	No	No	Not avail	
250ct73	SST 5 x 4	13	23	No	302	1000	1 NE	Tow	No	Yes	No	No	No	Not avail	
		14	23	No	302	1500	2 NE	Tow	No	Yes	Yes	10 ms	Yes	Not avail	
		15	23	No	122	2500	2 NE	Tow	2sta	Yes	Yes	10 ms	No	Not avail	

Table III-3 (cont'd)

<u>Date</u>	<u>Mission No.</u>	<u>Trial</u>	<u>Gun type</u>	<u>Flare good</u>	<u>Hdg (deg)</u>	<u>Ht AGL</u>	<u>Offset (km)</u>	<u>Tgt</u>	<u>Cine data</u>	<u>Radar data</u>	<u>Gun crew</u>		<u>Gun data recorded</u>	<u>Mid-time trial</u>	<u>Remarks</u>
											<u>Track</u>	<u>Fire pedal</u>			
29Oct73	SST-7	16	23	Yes	302	5500	2 NE	Tow	Yes	Yes	Yes	6 ms	Yes	Not avail	
		17	23	Yes	302	1000	1 NE	Tow	Yes	Yes	Yes	6 ms	Yes	Not avail	
		18	23	No	122	1500	2 NE	Tow	No	Yes	No	No	No	Not avail	
		19	23	No	122	2500	1 NE	Tow	No	Yes	Yes	6 ms	Yes	Not avail	
30Oct73	SST-8	20	23	Yes	122	2500	1 NE	Tow	3sta	Yes	Yes	10 ms	Yes	Not avail	
		21	23	Yes	122	1500	2 NE	Tow	4sta	Yes	No	10 ms	Yes	Not avail	
		22	23	No	122	2500	1 NE	Tow	No	Yes	No	No	No	Not avail	
		23	23	Yes	122	2500	1 NE	Tow	4sta	Yes	Yes	10 ms	Yes	Not avail	
31Oct73	SST-9	24	23	Yes	302	5500	2 NE	Tow	3sta	Yes	Yes	10 ms	Yes	Not avail	
		25	23	Yes	302	1000	1 NE	Tow	4sta	Yes	Yes	10 ms	Yes	Not avail	
		26	23	No	122	1500	2 NE	Tow	2sta	Yes	No	No	No	Not avail	
		27	23	CHX	N/A	N/A	N/A	N/A	N/A	N/A	N/A	N/A	N/A	N/A	
1Nov73	SST-10	28	23	Yes	122	1500	2 NE	Tow	3sta	No	Yes	6 ms	Yes	Not avail	
		29	23	No	122	2500	1 NE	Tow	4sta	Yes	No	No	No	Not avail	
		30	23	No	122	2500	1 NE	Tow	6sta	Yes	No	No	No	Not avail	
		31	23	No	122	2500	1 NE	Tow	5sta	Yes	No	No	No	Not avail	
		32	23	No	122	2500	1 NE	Tow	7sta	Yes	Yes	6 ms	Yes	Not avail	
		33	23	No	122	1000	1 SW	Tow	6sta	Yes	Invalid	N/A	Invalid	Not avail	
2Nov73	SST-11	34	23	No	180	5500	2 E	Tow	4sta	Yes	No	No	No	Not avail	

Table III-3 (cont'd)

Date	Mission No.	Trial No.	Gun type	Flare good	Hdg (deg)	Ht AGL	Offset (km)	Igt	Cine data	Radar data	Gun crew		Gun data recorded	Mid-time trial	Remarks	
											Track	Fire pedal				
2Nov73	SST-11	35	23	Yes	180	2500	1 W	Tow	6sta	Yes	Yes	Yes	Yes	Not avail		
		36	23	Yes	360	1500	2 W	Tow	6sta	Yes	Yes	Yes	Yes	Not avail		
		37	23	Yes	360	1000	1 E	Tow	9sta	Yes	Yes	Yes	Yes	Not avail		
		38	23	Yes	180	2500	1 E	Tow	9sta	Yes	Yes	Yes	Yes	Not avail		
		39	23	No	360	1000	1 W	Tow	9sta	Yes	Yes	Yes	Yes	Not avail		
		40	57	Yes	122	5000	2 NE	Tow	9sta	Some	No	No	Yes	Yes	Not avail	Changed to 57-mm
		41	57	Yes	122	1000	1 NE	Tow	9sta	Yes	Yes	8 rms	Yes	Yes	Not avail	
		42	57	Yes	302	1000	1 NE	Tow	9sta	Yes	Yes	10 rms	Yes	Yes	Not avail	
		43	57	Yes	302	1500	2 NE	Tow	9sta	Yes	Yes	8 rms	Yes	Yes	Not avail	
15Nov73	SST-13	44	57	No	122	1000	1 NE	Tow	9sta	Yes	Yes	No	Yes	Not avail		
		CNX	N/A	N/A	N/A	N/A	N/A	N/A	N/A	N/A	N/A	N/A	N/A	N/A	N/A	
		45	57	Yes	360	2500	1 W	Tow	0sta	Yes	Yes	Yes	Yes	Not avail	300 knots plus	
		46	57	Yes	360	2000	2 E	Tow	Z	Yes	Yes	Yes	Yes	Not avail	300 knots plus	
		47	57	No	360	2500	1 W	Tow	Z	Yes	Yes	No	Yes	Not avail	300 knots plus	
		48	57	No	180	1000	1 E	Tow	Z	Yes	Yes	No	Yes	Not avail	300 knots plus	
		49	57	Yes	360	2500	1 W	Tow	5sta	Yes	Yes	Yes	Yes	Not avail	300 knots plus	
		50	57	Yes	360	4500	3 E	Tow	4sta	Yes	Yes	Yes	Yes	Not avail	300 knots plus	
		51	57	Yes	180	2500	1 W	Tow	6sta	Yes	Yes	Yes	Yes	Not avail	Gun crew did not p/u tgt until 2 km before c/o	

Table III-3 (cont'd)

Date	Mission No.	Trial No.	Gun type	Flare good	Hdg (deg)	Ht AGL	Offset (km)	Int	Cine data	Radar data	Sun crew		Gun data recorded	Mid-time trial	Remarks
											Track	Fire pedal			
16Nov73	SST-15	52	57	Yes	180	1000	2 E	Tow	5sta	Yes	Yes	Yes	Yes	Not avail	
20Nov73	SST-17	53	57	Yes	122	5500	2 NE	Tow	6sta	Yes	Yes	2 ms	Yes	1944:20	No TOF
		54	57	Yes	122	1000	1 NE	Tow	6sta	Yes	Yes	No	Yes	1955:00	
		55	57	Yes	122	1000	1 NE	Tow	6sta	Yes	Yes	4 ms	Yes	2001:59	No TOF
		56	57	Yes	122	5000	1 NE	Tow	5sta	Yes	Yes	Yes	Invalid	2016:40	48 TOFs; 43 time skips
21Nov73	SST-18	57	57	No	122	1000	1 NE	Tow	3sta	Yes	No	No	No	2055:00	
		58	57	No	122	1000	1 NE	Tow	3sta	Yes	No	No	No	2102:30	
		59	57	No	122	1000	1 NE	Tow	3sta	Yes	No	No	No	2109:30	
		60	57	No	122	1000	1 NE	Tow	3sta	Yes	No	No	No	2117:00	
		61	57	No	122	1000	1 NE	Tow	2sta	Yes	Yes	4 ms	Yes	2125:00	
11Dec73	SST-19	62	23	Yes	302	5500	2 NE	Tow	5sta	Yes	Yes	Yes	Yes	1808:44	Changed to 23 camera rate 24 fps
		63	23	Yes	122	3000	1 NE	Tow	4sta	Yes	Partial	Yes	Yes	1915:00	
		64	23	Yes	122	1500	2 NE	Tow	7sta	Yes	Yes	Yes	Yes	1822:43	
		65	23	Yes	302	1000	1 NE	Tow	7sta	Yes	Yes	Yes	Yes	1836:23	
12Dec73	SST-20	66	23	No	180	2500	1 E	Tow	4sta	Yes	No	No	No	Not avail	
		67	23	No	360	1500	2 E	Tow	1sta	Yes	No	No	No	Not avail	
		68	23	No	180	2500	1 W	Tow	4sta	Yes	Partial	Yes	No	1511:35	
		69	23	No	360	1500	2 W	Tow	2sta	Yes	Partial	Yes	No	1518:58	
		70	23	No	180	2500	1 W	Tow	4sta	Yes	No	No	Yes	Not avail	
		71	23	No	360	1500	2 W	Tow	3sta	Yes	Yes	Yes	Yes	1532:45	
4Feb74	SST-21	CNX	N/A	N/A	N/A	N/A	N/A	N/A	N/A	N/A	N/A	N/A	N/A	N/A	
5Feb74	SST-22	72	23/57	Yes	122	5000	3 NE	Tow	0sta	Yes	57 some 23 none	No	Yes	1907:28	
		73	23/57	Yes	122	1000	1 NE	Tow	5sta	Yes	Yes	Yes	Yes	1722:28	
		74	23/57	Yes	302	1500	2 NE	Tow	6sta	Yes	Yes	Yes	Yes	1730:28	
		75	23/57	Yes	302	2500	2 NE	Tow	6sta	Yes	Yes	Yes	Yes	1737:29	

Table III-3 (cont'd)

Date	Mission No.	Trial No.	Gun type	Flare good	Hdg (deg)	Ht AGL	Offset (km)	Igt	Cine data	Radar data T+15 sec	Gun crew		Gun data recorded	Mid-time trial	Remarks
											Track	Fire pedal			
6Feb74	SST-23	76	23/57	Yes	180	2500	1 E	Tow	1sta	Until T+15 sec	Yes	Yes	Yes	1945:17	
		77	23/57	Yes	180	1500	2 W	Tow	4sta	Yes	Yes	Yes	Yes	1954:31	
		78	23/57	No	360	1000	1 W	Tow	1sta	Yes	No	No	No	2004:30	
		79	23/57	No	360	5500	2 E	Tow	1sta	Yes	No	No	No	2011:35	
7Feb74	SST-24	CNX	N/A	N/A	N/A	N/A	N/A	N/A	N/A	N/A	N/A	N/A	N/A	N/A	
8Feb74	SST-25	80	23/57	No	122	5000	2 NE	Tow	0sta	Yes	Yes	Yes	Yes	2248:19	
		81	23/57	No	122	1500	1 NE	Tow	0sta	Yes	Yes	Yes	Yes	2258:30	
11Feb74	SST-26	82	23/57	Yes	122	2500	1 NE	Tow	2sta	No	No	No	No	1806:40	
		83	23/57	Yes	122	1900	2 NE	Tow	3sta	Yes	Yes	Yes	Yes	1813:53	No TOF-57
		84	23/57	Yes	302	1000	1 NE	Tow	3sta	Yes	Yes	Yes	Yes	1829:35	No TOF-57
		85	23/57	Yes	302	5500	2 NE	Tow	1sta	Yes	Yes	Yes	Yes	1837:12	No TOF-57
12Feb74	SST-27	CNX	N/A	N/A	N/A	N/A	N/A	N/A	N/A	N/A	N/A	N/A	N/A	N/A	
13Feb74	SST-28	CNX	N/A	N/A	N/A	B/A	N/A	N/A	N/A	N/A	N/A	N/A	N/A	N/A	
19Feb74	SST-29	86	23/57	Yes	122	5000	2.5 NE	Tow	8sta	Yes	Yes	Yes	Yes	1724:13	
		87	23/57	Yes	122	2500	1.3 NE	Tow	7sta	Yes	Yes	Yes	Yes	1734:47	
		88	23/57	Yes	302	1000	1 NE	Tow	5sta	Yes	Yes	Yes	Yes	1744:45	
		89	23/57	Yes	302	2500	1 NE	Tow	5sta	Yes	Yes	Yes	Yes	1752:00	
20Feb74	SST-30	CNX	N/A	N/A	N/A	N/A	N/A	N/A	N/A	N/A	N/A	N/A	N/A	N/A	
21Feb74	SST-31	90	23/57	Yes	122	5000	2 NE	Tow	7sta	Yes	Yes	Yes	Yes	1846:55	
		91	23/57	Yes	122	1000	1 NE	Tow	7sta	Yes	57-yes 23-poor	Yes	Yes	1853:38	
		92	23/57	Yes	302	1500	2 NE	Tow	4sta	Yes	57-poor 23-yes	Yes	Yes	1902:50	
		93	23/57	Yes	302	2500	1 NE	Tow	6sta	Yes	Yes	Yes	Yes	1909:33	
25Feb74	SST-32	94	23/57	Yes	180	5500	2 E	Tow	5sta	Yes	Yes	Yes	Yes	1943:58	
		95	23/57	Yes	180	1000	1 W	Tow	8sta	Yes	Yes	Yes	Yes	1952:38	
		96	23/57	Yes	360	1500	2 W	Tow	6sta	Yes	Yes	Yes	Yes	2003:03	

Table III-3 (cont'd)

Date	Mission No.	Trial No.	Gun type	Flare good	Hdg (deg)	Ht AGL	Offset (km)	Tgt	Cine data	Radar data	Track	Fire pedal	Gun data recorded	Mid-time trial	Remarks
25Feb74	SST-32	97	23/57	Yes	360	2500	1 E	Tow	5sta	Yes	Yes	Yes	Yes	2013:05	
26Feb74	SST-33	98	23/57	Yes	122	2500	1 NE	Tow	6sta	Yes	57-yes 23-poor	57-4rms 23-5rms	Yes	2057:50	23-jammed; terminate 23
		99	23/57	Yes	122	1500	2 NE	Tow	7sta	Yes	23-no 57-yes	23-no 57-4rms	Yes	2114:20	
		100	23/57	No	302	1000	1 NE	Tow	Osta	Yes	No	No	No	2120:40	
		101	23/57	Yes	302	5500	2 NE	Tow	Osta	Yes	57-poor 23-no	No	No	2128:12	Weak flare
1Mar74	SST-34	102	23/57	Yes	302	5500	2 NE	Tow	7sta	Yes	Yes	23-6rms 57-4rms	Yes	2010:30	Only 5 TOF on 23
		103	23/57	Yes	302	1000	1 NE	Tow	7sta	Yes	Yes	23-6rms 57-4rms	Yes	2017:01	Only 7 TOF on 23; re- place press t'ducer-23
		104	23/57	Yes	122	1500	2 NE	Tow	7sta	Yes	Yes	23-6rms 57-4rms	Yes	2032:47	7 TOF record 1 at turn on
		105	23/57	No	122	2500	1 NE	Tow	7sta	Yes	No	No	No	2039:23	
11Nov74	SST-103	221	XM-42A	N/A	167	3000	1.5 E	F-4	10sta	Yes	Yes	Yes	Yes	1503:16	
		222	XM-42A	N/A	167	3000	1.4 W	F-4	10sta	Yes	Yes	Yes	Yes	2212:29	
		223	XM-42A	N/A	347	3000	1 E	F-4	10sta	No	No	No	Yes	2216:15	
		224	XM-42A	N/A	347	3000	1.4 W	F-4	9sta	Yes	Yes	Yes	Yes	2221:01	
		225	XM-42A	N/A	302	1500	1 NE	F-4	9sta	Yes	Yes	Yes	Yes	2226:05	
		226	XM-42A	N/A	302	5500	2.0 NE	F-4	10sta	Yes	Yes	Yes	Yes	2231:55	
		227	XM-42A	N/A	122	5500	2.0 NE	F-4	9sta	Yes	No	No	Yes	2235:49	No lock on
		228	XM-42A	N/A	122	1500	1.1 NE	F-4	4sta	Yes	Yes	Yes	Yes	2240:30	
		229	XM-42A	N/A	122	5500	2.0 NE	F-4	7sta	Yes	Yes	Yes	Yes	2245:17	Out of film
4Nov74	SST-104	230	XM-42A	N/A	167	3000	1.3 E	F-4	7sta	Yes	Yes	Yes	Yes	1521:35	Laser track T-40-T+29
		231	XM-42A	N/A	167	3000	1.2 W	F-4	8sta	Yes	Yes	Yes	Yes	1528:09	Laser track T-30-T+44
		232	XM-42A	N/A	347	3000	1.3 E	F-4	8sta	Yes	Yes	Yes	Yes	1534:27	Laser track T-33-T+11 T+31-T+44
		233	XM-42A	N/A	347	3000	1 W	F-4	7sta	Yes	Yes	Yes	Yes	1539:20	Laser track T-26-T+45

Table III-3 (cont'd)

<u>Date</u>	<u>Mission No.</u>	<u>Trial No.</u>	<u>Gun type</u>	<u>Flare good</u>	<u>Hdg (deg)</u>	<u>Ht AGL</u>	<u>Offset (km)</u>	<u>Tgt</u>	<u>Cine data</u>	<u>Radar data</u>	<u>Gun crew</u>		<u>Gun data recorded</u>	<u>Mid-time trial</u>	<u>Remarks</u>
											<u>Track</u>	<u>Fire pedal</u>			
4Nov74	SST-104	234	XM-42A	N/A	302	1500	1.5 NE	F-4	7sta	Yes	Yes	Yes	1543:23	Laser track T-19-T+44	
		235	XM-42A	N/A	302	5500	2.0 NE	F-4	7sta	Yes	Yes	Yes	1540:19	Laser track T-22-T+43	
		236	XM-42A	N/A	122	5500	1 NE	F-4	9sta	Yes	Yes	Yes	1604:37	Laser track T-46-T+43	
		237	XM-42A	N/A	122	1500	1.1 NE	F-4	9sta	Yes	Yes	Yes	1618:21	Laser track T-14-T+44	
		238	XM-42A	N/A	302/ 167	3000	1.6 N	F-4	9sta	Yes	Yes	Yes	1622:21	Laser track T+15-T+23	
		239	XM-42A	N/A	302/ 167	3000	1.6 N	F-4	8sta	Yes	Yes	No	1628:39	Laser track T-41-T+25 T-30-T+34	
		240	XM-42A	N/A	302	1500	1 NE	F-4	8sta	Yes	Yes	Yes	1634:15	Laser track T-19-T+44	

g. Ht AGL. Nominal height of the tow target or the F-4 aircraft above ground level. The actual height varied up to ± 200 feet because of the long tow cable length.

h. Offset. The distance and direction from the RCS origin that was nominally programmed in the preflight briefing. Numbers indicate kilometers from the RCS and letters stand for directions in the eight cardinal directions from the RCS.

i. Tgt. The type of target used. The first mission used the A-4 safety chase as the target. All other trials utilized the TDU-25 or the F-4 aircraft as targets.

j. Cine data. Range Support Controller's initial estimate of the amount of cinetheodolite coverage. The number of cinetheodolite stations tracking are included. General comments are "No" for no cinetheodolite coverage, "Yes" for valid cinetheodolite coverage, and "Z" for questionable coverage. A minimum of three stations was required for a cinetheodolite solution for data analysis.

k. Radar data. Two radar stations generally tracked the targets which were equipped with luneberg lenses. A "Yes" in the table indicates a valid track by one radar. A "No" in the table indicates questionable data primarily due to the chase aircraft in the radar gate.

l. Gun crew. The gun crews were asked if they tracked the target and if they attempted to fire. For scheduled nonfiring trials, the attempt to fire (fire pedal) was recorded as a "Yes." For firing trials the number of rounds fired was recorded. On several trials the gun crew tracked the safety chase rather than the tow target and these trials are marked "Invalid" in the Track column.

m. Gun data recorded. The data in this column were gathered from EG&G at the debriefing session. It indicates whether gun data were collected by the computer during nonfiring and firing trials. If data were collected but were invalidated for some reason at the debriefing session, an "Invalid" is indicated.

n. Mid-time trial. The column reflects the cross over time of target during trial. The crossover time is the time at which the target passed closest to the gun systems. The time is recorded in ZULU time to the nearest second.

o. Remarks. This column is reserved for pertinent comments for which no specific columns were provided.

3. DATA SUMMARIES

Table III-4 provides a summary of the HITVAL I dynamic test data and contains statistical information on 32 trials. Table III-5 contains similar information on HITVAL II for 16 trials. A brief explanation of each data element for tables III-4 and III-5 is provided for the reader's convenience.

a. A trial consisted of one pass of the target by the gun system. Only trials which contained complete data are shown in the summary.

b. The gun system used is indicated in the second column.

c. The error statistics column contains the mean, standard deviation, and percent of data within ± 0.8 mrad for azimuth, elevation and radial on each trial.

d. Intervals indicating total data spread were determined and are shown in the next column. These intervals were determined for azimuth, elevation and radial by determining the maximum value and minimum value.

e. The time of track provides the time from the start of tracking data to the end of tracking data for each trial. A data point occurs each 0.1 second. Data points which require a time interpolation of 0.2 second or greater for HITVAL I, and more than 0.1 for HITVAL II from a camera frame were classified as unacceptable. The time of unacceptable tracking data obtained during the trial is shown as well as the time of the longest continuous acceptable track.

f. The number of data points is the sum of the 0.1-second samples of data that are acceptable for statistical analysis. These data points are all the 0.1-second intervals in which the closest gun camera frame is less than 0.2 second away from the data point.

The error statistics in table III-4 reveal that the azimuth mean error varied from a high of 5.6 mrad to a low of 0.0 mrad, with an overall mean of 0.18 mrad. The magnitude of the elevation mean error had a high of 6.7 mrad and a low of 0.0 mrad with an overall mean of 0.07 mrad. The azimuth mean error was significantly larger during dynamic tests in contrast to static tests; however, the elevation mean error remained essentially the same in both

Table III-4
HITVAL I STATISTICAL SUMMARY

Irial	Gun type	Error statistics						±0.8 mrad (%)	100% data fall between (mrad)	Time of track		Longest contin. sec	Number data points	
		Mean (mrad)		Std Dev (mrad)		Total sec	Dropouts unaccept sec							
		AZ	EL	Rad	AZ	EL	Rad	AZ	EL	Rad				
2*	ZU-23	0.0	0.6	1.4	1.7	0.7	1.3	64	58	39	5.3	2.0	2.4	33
4*	ZU-23	2.0	2.8	3.5	1.8	1.2	1.6	8	0	0	4.5	0.6	2.2	39
7*	ZU-23	0.8	-1.2	1.6	0.5	0.5	0.4	49	29	0	4.7	0.0	4.7	47
8*	ZU-23	5.6	6.7	10.2	5.3	7.2	7.0	28	6	4	5.1	0.4	4.2	47
35	ZU-23	-0.3	-0.5	2.0	1.4	1.9	1.3	70	22	15	25.7	10.1	11.6	156
36	ZU-23	-1.4	-0.7	2.0	3.8	0.9	3.7	55	52	24	48.6	14.1	13.1	345
46	S-60	1.0	0.5	1.5	1.2	0.3	0.7	22	80	9	19.1	2.8	1.9	163
49	S-60	0.6	0.6	1.2	1.2	0.6	0.8	65	62	30	57.4	18.9	1.8	385
50	S-60	0.5	1.0	1.3	0.8	0.4	0.5	73	22	8	51.7	16.1	1.9	356
52	S-60	-0.1	1.1	1.3	0.7	0.4	0.6	85	22	15	53.6	7.8	3.3	458
73	S-60	-1.3	-0.5	1.5	0.5	0.4	0.5	17	70	9	27.2	0.0	27.2	272
74	ZU-23	-0.6	-1.4	1.7	0.5	0.4	0.3	54	2	0	45.9	10.1	30.2	358

*Data have errors; trials not reaccomplished (see section III.5.a(12)(b) and (c)).

Table III-4 (cont'd)

Trial	Gun type	Mean (mrad)				Std dev (mrad)				±0.8 mrad (%)				100% data fall between (mrad)	Time of track		Longest contin. sec	Number data points
		AZ	EL	Rad		AZ	EL	Rad		AZ	EL	Rad			Total sec	Dropouts unaccept sec		
74	S-60	0.3	-0.7	1.1	0.8	0.4	0.4	0.4	0.4	52	58	34	34	AZ[-1.1,1.7] EL[-1.3,0.5] Rad[0.2,1.9]	34.2	0.0	34.2	342
75	ZU-23	-0.7	-0.5	1.0	0.4	0.4	0.2	0.2	0.2	51	75	27	27	AZ[-1.5,0.3] EL[-1.6,0.5] Rad[0.3,1.7]	32.2	1.3	29.6	309
75	S-60	1.1	-0.1	1.1	0.6	0.3	0.6	0.6	0.6	35	97	35	35	AZ[-0.1,2.5] EL[-1.2,0.7] Rad[0.0,2.4]	44.5	1.2	36.0	433
77	ZU-23	0.6	-0.9	1.1	0.4	0.2	0.3	0.3	0.3	78	42	7	7	AZ[-0.7,2.4] EL[-1.7,-0.2] Rad[0.5,2.7]	12.0	2.9	3.2	91
84	ZU-23	-1.6	-0.5	2.2	0.9	1.6	1.1	1.1	1.1	10	57	3	3	AZ[-4.8,3.4] EL[-5.7,8.4] Rad[0.5,8.4]	15.5	4.0	1.6	115
86	S-60	0.7	-0.2	0.7	0.5	0.3	0.4	0.4	0.4	51	97	54	54	AZ[-0.6,2.5] EL[-2.3,1.6] Rad[0.0,3.1]	30.0	0.9	25.6	291
86	ZU-23	-0.3	-0.1	0.6	0.5	0.4	0.4	0.4	0.4	78	92	70	70	AZ[-2.4,1.5] EL[-1.6,1.3] Rad[0.0,2.3]	47.2	4.5	24.9	427
87	S-60	-0.1	0.0	0.8	0.8	0.4	0.3	0.3	0.3	60	96	54	54	AZ[-1.5,1.2] EL[-1.1,1.6] Rad[0.1,2.0]	38.5	1.9	33.6	366
87	ZU-23	-0.4	-0.6	0.9	0.4	0.6	0.4	0.4	0.4	92	58	47	47	AZ[-1.4,2.0] EL[-2.0,0.7] Rad[0.1,2.0]	42.1	0.2	41.3	419
88	S-60	0.7	-0.1	1.0	0.8	0.5	0.6	0.6	0.6	52	88	42	42	AZ[-0.8,2.3] EL[-1.0,2.0] Rad[0.0,2.9]	43.9	0.2	35.5	437
88	ZU-23	0.4	-1.0	1.2	0.5	0.3	0.4	0.4	0.4	72	25	20	20	AZ[-0.8,1.4] EL[-1.8,-0.2] Rad[0.3,2.3]	30.4	0.0	30.4	304
89	S-60	1.2	-0.3	1.3	1.3	0.5	1.2	1.2	1.2	35	87	21	21	AZ[-1.6,16.7] EL[-1.1,1.9] Rad[0.2,16.5]	37.3	2.6	34.5	347
89	ZU-23	-0.1	-0.6	0.7	0.4	0.6	0.4	0.4	0.4	97	66	62	62	AZ[-1.1,0.7] EL[-1.8,0.6] Rad[0.0,1.9]	46.6	0.0	46.6	466

Table III-4 (cont'd)

Trial	Gun type	Mean (mrad)				Error statistics				±0.8 mrad (%)	100% data fall between (mrad)	Time of track			Longest contin. sec	data points
		AZ	EL	Rad	Rad	AZ	EL	Rad	Rad			Total sec	Oropouts unaccept sec			
90	S-60	1.0	0.3	0.4	0.5	0.4	0.5	0.9	0.9	35	82	AZ[0.2,3.6] EL[-1.7,1.4] Rad[0.3,3.4]	17.6	1.9	10.9	157
91	S-60	-0.5	0.2	1.1	1.1	0.9	0.9	0.9	0.9	30	97	AZ[-1.9,2.9] EL[-3.2,1.3] Rad[0.5,11.3]	21.8	3.7	11.4	181
98	ZU-23	-1.5	-0.5	1.8	1.8	1.4	1.0	1.0	1.0	8	62	AZ[-3.0,8.9] EL[-5.8,2.6] Rad[0.2,9.5]	13.9	1.5	10.2	124
99	S-60	-0.4	0.0	0.6	0.6	0.5	0.6	0.6	0.6	83	98	AZ[-1.4,2.9] EL[-4.6,0.7] Rad[0.0,5.4]	14.1	3.1	6.0	110
102	ZU-23	-0.8	1.1	1.5	1.3	1.0	1.1	1.1	1.1	3	32	AZ[-3.0,8.0] EL[-6.9,5.3] Rad[0.0,7.0]	26.0	1.9	9.8	241
103	ZU-23	-0.5	-0.8	1.6	2.2	0.8	1.8	1.8	1.8	50	52	AZ[-1.9,18.9] EL[-3.1,2.3] Rad[0.0,17.8]	11.4	1.2	8.5	102
104	ZU-23	-0.3	-1.6	1.8	0.8	0.6	0.6	0.6	0.6	75	8	AZ[-1.5,6.4] EL[-3.9,2.2] Rad[0.7,6.4]	25.5	0.5	12.7	250
(Averages)		(0.18)	(0.07)	(1.65)	(1.10)	(0.84)	(1.01)	(53.0)	(56.1)	(25.2)	(3.6)	(29.2)	(16.9)	(255)		

Table III-5

HITVAL II STATISTICAL SUMMARY

Trial	Gun type	Mean (mrad)			Std dev (mrad)			±0.8 mrad (%)			100% data fall between (mrad)	Time of track		Number data points	
		AZ	EL	Rad	AZ	EL	Rad	AZ	EL	Rad		Total sec	Dropouts unaccept sec		Longest contin. sec
221	XM-42A	0.1	0.7	0.7	0.2	0.2	0.2	100	72	67	AZ[-0.2,0.4] EL[0.1,1.3] Rad[0.1,1.4]	40.1	31.6	8.5	85
222	XM-42A	0.8	-0.1	0.8	0.4	0.5	0.5	43	99	52	AZ[0.0,1.4] EL[-0.8,0.5] Rad[0.1,1.4]	37.1	2.8	20.5	347
224	XM-42A	-0.6	-0.1	0.7	0.4	0.8	0.7	70	97	72	AZ[-1.5,0.3] EL[-1.2,0.7] Rad[0.0,1.3]	40.1	3.1	35.8	372
225	XM-42A	-0.9	0.1	0.9	0.6	0.3	0.5	62	99	61	AZ[-2.6,0.3] EL[-0.6,0.8] Rad[0.1,2.3]	33.6	1.8	19.5	325
226	XM-42A	-0.1	-0.4	0.6	0.7	0.3	0.3	77	90	75	AZ[-2.3,1.4] EL[-1.6,0.5] Rad[0.1,1.6]	36.6	0.0	36.6	366
228	XM-42A	-1.0	0.1	1.0	0.5	0.6	0.6	46	97	38	AZ[-2.1,0.0] EL[-0.8,0.9] Rad[0.1,2.0]	36.6	3.0	27.4	340
230	XM-42A	-0.2	-0.4	1.3	1.7	3.6	3.7	79	91	69	AZ[-1.6,4.0] EL[-1.8,8.8] Rad[0.2,8.9]	39.5	14.2	20.6	269
231	XM-42A	0.3	0.1	0.7	0.9	0.6	0.8	71	95	65	AZ[-0.9,1.4] EL[-0.5,1.1] Rad[0.1,1.3]	38.6	11.1	11.4	287
232	XM-42A	-0.5	0.4	0.8	0.6	1.4	1.3	76	90	58	AZ[-2.2,0.9] EL[-0.8,1.0] Rad[0.0,1.8]	37.5	3.1	15.5	352
233	XM-42A	-0.6	1.0	1.2	0.5	1.5	1.4	71	46	29	AZ[-1.6,0.7] EL[-0.2,1.7] Rad[0.1,2.1]	36.7	5.0	22.3	325
234	XM-42A	-0.8	-0.2	0.9	0.5	1.0	0.9	57	88	48	AZ[-2.1,0.0] EL[-1.5,1.1] Rad[0.1,1.8]	34.2	6.6	17.7	282
235	XM-42A	-0.6	-0.4	0.9	0.5	0.8	0.5	62	76	47	AZ[-2.0,0.6] EL[-2.0,1.0] Rad[0.1,2.0]	38.8	0.3	20.0	387

Table III-5 (cont'd)

Trial	Gun type	Mean (mrad)		Error statistics			±0.8 mrad (%)		100% data fall between (mrad)	Time of track			Number data points									
		AZ	EL	AZ	EL	Rad	AZ	EL		Rad	Total sec	Dropouts unaccept sec		Longest contin. sec								
236	XM-42A	-0.9	0.2	1.1	1.1	1.0	1.0	1.0	1.0	37	84	30	AZ[-2.5,0.6] EL[-1.2,1.2] Rad[0.1,2.0]	39.2	8.8	19.5	316					
237	XM-42A	-0.8	0.2	1.2	1.2	1.4	0.8	1.3	1.3	49	86	39	AZ[-2.7,0.7] EL[-1.2,1.5] Rad[0.1,2.6]	33.2	5.8	13.3	284					
238	XM-42A	-1.2	-0.2	1.4	0.8	2.0	1.8	1.8	1.8	22	83	23	AZ[-2.7,0.2] EL[-1.6,1.1] Rad[0.3,2.3]	23.5	4.7	18.1	193					
240	XM-42A	-0.5	0.5	1.0	1.1	0.6	1.0	1.0	1.0	68	65	35	AZ[-1.6,1.0] EL[-0.5,1.5] Rad[0.0,1.7]	31.3	1.4	20.2	305					
(Averages)										(-0.47)	(0.09)	(0.95)	(0.74)	(1.01)	(1.03)	(61.9)	(84.9)	(50.5)	(36.0)	(6.5)	(20.4)	(302.2)

cases. The azimuth standard deviation for the ZU-23 and S-60 Guns was three times larger during dynamic tests than during static tests. The elevation standard deviation for both guns was approximately 40 percent larger during dynamic tests than during static tests. Table III-4 also reveals that 53 percent and 56 percent of the mean azimuth and elevation errors, respectively, were within the specified ± 0.8 -mrad accuracy requirements. The average trial during HITVAL I was 29.2 seconds in duration with an average continuous track time of acceptable data points of 16.9 seconds, and an average number of acceptable data points of 255.

The HITVAL II data summaries presented in table III-5 contains information on 16 valid trials. A review of table III-5 indicates that the azimuth mean error ranged from -1.2 mrad to +0.8 mrad and an overall mean average of -0.47 mrad. Elevation mean errors ranged from -0.4 mrad to +1.0 mrad range with an average of +0.09 mrad. The standard deviation was approximately 2 and 3 times larger in azimuth and elevation, respectively, during dynamic tests than during static tests involving the XM-42A gun. The percentage of data points within ± 0.8 mrad was much larger during HITVAL II than HITVAL I. On the average, 62 percent of azimuth errors and 85 percent of elevation errors during HITVAL II were within ± 0.8 mrad, in contrast to 53 percent of azimuth errors and 56 percent of elevation errors in HITVAL I. The average trial during HITVAL II was 36 seconds in duration with a continuous track time of 20.4 seconds, and the number of acceptable data points was 302.

Table III-6 is a comparison of mean and standard deviation data on the three guns. Although not specified, ideally the mean should have been zero for all guns. It shows the overall mean varied from -0.46 to +0.34 mrad. However, investigation of individual trials revealed that the mean wandered even greater than the overall means. The standard deviation is within the 0.8-mrad accuracy requirement for azimuth on Gun 5 and both azimuth and elevation on Gun 2. It is interesting to note that the standard deviation of azimuth and elevation errors increased during dynamic SSTs over the results obtained during static SSTs (table II-1). On Gun 1 the azimuth and elevation standard deviation increased in magnitude by about 4.5 and 2 times, respectively. Gun 5 azimuth and elevation standard deviation was about 2 and 3 times larger during dynamic testing. Gun 2 showed a reduction in elevation standard deviation from 0.59 to 0.46 mrad or about 22 percent; however, azimuth standard deviation doubled in magnitude. The dynamic scoring measurements showed better overall

Table III-6

DYNAMIC SCORING SYSTEM TEST RESULTS (ERROR STATISTICS) (mrad)

	<u>ZU-23 (Gun 1)</u>		<u>S-60 (Gun 2)</u>		<u>XM-42A (Gun 5)</u>	
	<u>AZ</u>	<u>EL</u>	<u>AZ</u>	<u>EL</u>	<u>AZ</u>	<u>EL</u>
Mean	0.05	0.02	0.34	0.13	-0.46	0.09
Standard deviation	1.34	1.13	0.79	0.46	0.74	1.01
Number of trials	18		14		16	

repeatability in azimuth than either Gun 1 or Gun 2, but the elevation standard deviation was twice the value of Gun 2.

One of the three errors defined in planning for the system scoring tests was the uncertainty of the cinetheodolite position of the tow target during the dynamic portion of the HITVAL I system scoring test. This error is a function of (1) the uncertainty of geodetic positions of the cinetheodolite stations, (2) the cinetheodolite encoder accuracies, (3) the raw cinetheodolite position precision limits, and (4) the precision of smoothed cinetheodolite position limits.

(1) The positions of each cinetheodolite station were assumed to be accurate and errors derived from this assumption were very small. This assumption was made in the static tests for all the target poles. Errors in cinetheodolite position were assumed small as were errors in target pole position.

(2) Cinetheodolite encoder inaccuracies were identified by WSMR as minimum values. Variable errors were eliminated during pre- and postmission calibrations by computer subroutines based on calibration estimates. The encoder accuracies were used to determine the raw position precision sigmas.

(3) WSMR developed a raw data tape from the cinetheodolite range tape. The raw data tape included information on WSMR cinetheodolite azimuth and elevation encoder/photo analysis. WSMR estimated the precision of raw position based on the encoder accuracy limits. The estimate generated a standard deviation from which probabilities of position uncertainty were determined. From this probability estimate, approximations were made on the error limits of the raw position. The varying values of this standard deviation are plotted in annex C. These plots indicate the contribution of the

uncertainty of the cinetheodolite positions to the total errors identified by the system scoring test. A detailed description of raw position procedures is contained in appendix 4, paragraph G. Table III-7 was prepared to provide ranges of the cinetheodolite position standard deviations for each trial.

(4) If the raw positions developed from the raw tape referred to above were the final delivered product, then the accuracy limits referred to in the previous paragraph would be sufficient to designate the accuracy of each position. This, unfortunately, is not the case. The raw data tape was processed through a computer program that fitted a 21-point curve through each 21 raw points. The positions used in the final cinetheodolite position tape were determined from this smooth curve fitting process. The actual track of the target was a smooth curve and the smoothed data more closely fit the true trajectory than the raw position points. This correction to the raw position accuracy limit generally makes the standard deviation a smaller value. Because of the inability to subtract the error, only an approximation to the error limit of the cinetheodolite position uncertainty was provided. The smoothing residual plots for converting raw data positions to smoothed data positions are presented in annex C, part B. Table III-8 shows the average corrections for table III-7 to estimate cinetheodolite position uncertainties.

(5) Based on the above discussions, the following statements can be made about the cinetheodolite positions derived from the final delivered tape.

(a) The geodetic and encoder inaccuracies were considered negligible and insignificant.

(b) The raw position standard deviations indicate a maximum error bound on each position. From this data, a milliradian error bound was identified for the tracking sensor portion of the overall instrumentation errors identified in tables III-4 and III-5. This bound is smaller when the added constraint (smoothed curve) is included. The data described in paragraph (4) above provides an average figure less than this error bound.

(c) The raw position sigmas define some maximum error bound that is reduced, on the average, by the smoothing residuals.

Table III-7

RAW POSITION PRECISION

<u>Trial</u>	<u>Alt</u>	<u>Hdg</u>	<u>Offset</u>	<u>Radial sigma average (m)</u>	<u>Maximum sigma (m)</u>	<u>Minimum sigma (m)</u>	<u>99% sigma spread (m)</u>
2	1000	180	2 E	0.555	0.701	0.417	1.665
4	3000	360	2 E	0.455	0.880	0.259	1.365
7	1000	122	1 NE	2.164	3.053	1.012	6.492
8	1000	302	1 NE	2.353	3.046	1.530	7.059
11	5500	122	2 NE	0.768	3.946	0.000	2.304
21	1500	122	2 NE	0.431	1.576	0.024	1.293
25	1000	302	1 NE	4.105	8.953	0.245	12.32
35	2500	180	1 W	1.005	8.495	0.037	3.015
36	1500	360	2 W	0.594	1.472	0.268	1.782
46	2000	360	2 E	0.324	1.986	0.081	0.972
49	2500	360	1 W	0.362	3.832	0.041	1.086
50	4500	360	3 E	0.777	4.597	0.024	2.331
52	1000	180	2 E	0.362	2.188	0.070	1.086
57	1000	122	1 NE	3.109	14.655	0.049	9.327
74	1500	302	2 NE	0.759	7.519	0.088	2.277
75	2500	302	2 NE	0.403	1.127	0.112	1.209
77	1500	180	2 W	1.450	3.784	0.037	4.350
84	1000	302	1 NE	0.253	0.503	0.073	0.759

Table III-8

SMOOTHING RESIDUALS FOR CINETHEODOLITE POSITIONS

<u>Trial</u>	<u>Alt</u>	<u>Hdg</u>	<u>Offset</u>	<u>Mean</u>	<u>Maximum</u>	<u>Minimum</u>
					<u>Centimeters</u>	
73	1000	122	1 NE	24.8	78	12
74	1500	302	2 NE	24.0	43	6
75	2500	302	2 NE	15.6	34	6
77	1500	180	2 W	14.5	20	11
84	1000	302	1 NE	4.4	6	2
86	5000	122	2.5 NE	10.9	19	4
87	2500	122	1.3 NE	12.2	20	7
88	1000	302	1 NE	16.7	40	8
89	2500	302	1 NE	6.5	40	8
91	1000	122	1 NE	14.2	25	9
98	2500	122	1 NE	6.3	11	3
102	5500	302	2 NE	17.8	41	4
103	1000	302	1 NE	7.7	21	4
104	1500	122	2 NE	11.4	30	4

4. ANALYSIS

a. General

The process used to analyze the dynamic test data was rather complicated. Prior to testing, the assumptions were made that the data were random and that the data were normally distributed. The analytical approach was to evaluate specified statistical parameters against accuracy requirements. The initial trials provided very little data and in many cases were not continuous. Changes in data collection methodology were developed to provide better quality data of a continuous nature. Trial 72 and later trials reflect the improvements in data gathering, and no data prior to trial 72 were included in data summaries.

Attempts were made with hand calculations to fit early data (prior to trial 72) to the normal distribution without checking randomness. Half of these attempts failed to pass the chi-squared goodness of fit tests (see appendix 4, paragraph E, for discussion). Autocorrelation tests were then developed and accomplished on trials containing 10 seconds or more of continuous data to determine if the errors were random and if the process is stationary (see appendix 4, paragraph F, for detailed information and annex B for autocorrelation plots). After analyzing data on 26 trials, it became obvious that the data were nonstationary and thus not random. Attempts were made to determine the reason for this nonstationarity and several trials were analyzed using a time varying mean for the length of the trial. Plots of these time varying means are presented in annex B.

b. Data Error Analysis

The data generated are presented in several ways. Table III-9 lists the azimuth errors grouped in intervals centered at zero. Table III-10 lists the elevation errors grouped in the same manner. The tables are presented with percentages under the number of data points to assist the reader in making comparisons between trials. The purpose of this data error analysis was to determine the number of data samples within certain intervals for each trial. This procedure allows for flexibility since percentages or number of data points can be used as desired. The number of data points within each interval also allows the combination of trials for comparison purposes.

A summary of the data for all three guns, in azimuth and elevation, is presented in table I-3. The table shows that 68.9 percent of the 21,954 data points are within the ± 0.8 -mrad accuracy requirement. The azimuth for all

Table III-9
ERROR DATA (AZIMUTH)

Gun type	Trial No.	Total data points	Number of data points and percentage in each data interval									
			milliradians									
			<u>±0.2</u>	<u>±0.6</u>	<u>±0.9</u>	<u>±1.0</u>	<u>±1.4</u>	<u>±1.8</u>	<u>±2.2</u>	<u>±2.6</u>	<u>±3.0</u>	<u>±5.0</u>
ZU-23	74	358	72 20.1%	153 42.7%	193 53.9%	252 70.4%	353 98.6%	358 100%	358 100%	358 100%	358 100%	352 100%
ZU-23	75	309	35 11.3%	98 31.7%	156 50.5%	245 79.3%	308 99.7%	309 100%	309 100%	309 100%	309 100%	309 100%
ZU-23	77	91	4 4.4%	48 52.7%	71 78.0%	83 91.2%	89 97.8%	89 97.8%	90 98.9%	91 100%	91 100%	91 100%
ZU-23	84	115	2 1.7%	7 6.1%	11 9.6%	17 14.8%	46 40.0%	68 59.1%	90 78.3%	105 91.3%	107 93.0%	115 100%
ZU-23	86	427	136 31.9%	278 65.1%	333 78.0%	377 88.3%	419 98.1%	426 99.8%	426 99.8%	427 100%	427 100%	427 100%
ZU-23	87	419	106 25.3%	338 80.7%	386 92.1%	400 95.5%	416 99.3%	417 99.5%	419 100%	419 100%	419 100%	419 100%
ZU-23	88	304	49 16.1%	144 47.4%	220 72.4%	280 92.1%	304 100%	304 100%	304 100%	304 100%	304 100%	304 100%
ZU-23	89	466	161 34.5%	424 91.0%	452 97.0%	465 99.8%	466 100%	466 100%	466 100%	466 100%	466 100%	466 100%
ZU-23	98	124	2 1.6%	6 4.8%	10 8.1%	13 10.5%	31 25.0%	68 54.8%	101 81.5%	117 94.4%	122 98.4%	122 98.4%
ZU-23	102	241	73 30.3%	141 58.5%	152 63.1%	158 65.6%	164 68.0%	169 70.1%	175 72.6%	209 86.7%	239 99.2%	240 99.6%
ZU-23	103	102	11 10.8%	35 34.3%	51 50.0%	61 59.8%	89 87.3%	96 94.1%	99 97.1%	99 97.1%	99 97.1%	100 98.0%
ZU-23	104	250	84 33.6%	149 59.6%	187 74.8%	213 85.2%	245 98.0%	248 99.2%	248 99.2%	248 99.2%	248 99.2%	248 99.2%

Table III-9 (cont'd)

Gun type	Trial No.	Total data points	Number of data points and percentage in each data interval									
			milliradians									
			± 0.2	± 0.6	± 0.8	± 1.0	± 1.4	± 1.8	± 2.2	± 2.6	± 3.0	± 5.0
S-60	73	272	1 0.37%	8 2.9%	45 16.5%	84 30.9%	148 54.4%	214 78.7%	260 95.6%	272 100%	272 100%	272 100%
S-60	74	342	28 8.2%	129 37.7%	177 51.8%	244 71.3%	321 93.9%	342 100%	342 100%	342 100%	342 100%	342 100%
S-60	75	433	43 9.9%	116 26.8%	151 34.9%	180 41.6%	267 61.7%	402 92.8%	431 99.5%	433 100%	433 100%	433 100%
S-60	86	291	31 10.6%	109 37.5%	148 50.9%	221 75.9%	289 99.3%	289 99.3%	291 100%	291 100%	291 100%	291 100%
S-60	87	366	32 8.7%	144 39.3%	221 60.4%	297 81.1%	365 99.7%	366 100%	366 100%	366 100%	366 100%	366 100%
S-60	88	437	68 15.6%	180 41.2%	227 51.9%	271 62.0%	327 74.8%	395 90.4%	432 98.9%	437 100%	437 100%	437 100%
S-60	89	347	23 6.6%	68 19.6%	123 35.4%	172 49.6%	230 66.3%	290 83.6%	328 94.5%	345 99.4%	345 99.4%	345 99.4%
S-60	90	157	0 0%	13 8.3%	55 35.0%	86 54.8%	138 87.9%	152 96.8%	156 99.4%	156 99.4%	156 99.4%	157 100%
S-60	91	181	16 8.8%	37 20.4%	55 30.4%	94 51.9%	156 86.2%	179 98.9%	180 99.4%	180 99.4%	181 100%	181 100%
S-60	99	110	23 20.9%	75 68.2%	91 82.7%	96 87.3%	109 99.1%	109 99.1%	109 99.1%	110 100%	110 100%	110 100%
XM-42A	221	85	80 94.1%	85 100%	85 100%	85 100%	85 100%	85 100%	85 100%	85 100%	85 100%	85 100%
XM-42A	222	347	84 24.2%	256 73.8%	301 86.7%	345 99.4%	346 99.7%	346 99.7%	346 99.7%	346 99.7%	346 99.7%	346 99.7%
XM-42A	224	372	51 13.7%	187 50.3%	253 68.0%	318 85.5%	362 97.3%	371 99.7%	371 99.7%	371 99.7%	371 99.7%	371 99.7%

Table III-9 (cont'd)

Gun type	Trial No.	Total data points	Number of data points and percentage in each data interval									
			milliradians									
			± 0.2	± 0.6	± 0.8	± 1.0	± 1.4	± 1.8	± 2.2	± 2.6	± 3.0	± 5.0
XM-42A	225	325	23 7.1%	116 35.7%	177 54.4%	238 73.2%	258 79.4%	295 90.1%	315 96.9%	322 99.1%	323 99.4%	325 100%
XM-42A	226	366	118 32.2%	267 73.0%	296 80.9%	325 88.8%	355 97.0%	365 99.7%	365 99.7%	366 100%	366 100%	366 100%
XM-42A	228	347	16 4.7%	97 28.5%	141 41.5%	184 54.1%	251 73.8%	313 92.1%	338 99.4%	338 99.4%	339 99.7%	340 100%
XM-42A	230	269	54 20.0%	177 65.8%	214 79.6%	250 92.9%	260 96.6%	264 98.1%	264 98.1%	264 98.1%	264 98.1%	266 98.9%
XM-42A	231	287	122 42.5%	225 78.4%	252 87.8%	279 97.2%	279 97.2%	280 97.6%	280 97.6%	280 97.6%	282 98.3%	285 99.3%
XM-42A	232	352	107 30.4%	245 69.6%	266 76.1%	290 82.4%	312 88.6%	341 96.9%	352 100%	352 100%	352 100%	352 100%
XM-42A	233	325	54 16.6%	160 49.2%	221 68.0%	281 86.5%	319 98.2%	322 99.1%	322 99.1%	323 99.4%	323 99.4%	325 100%
XM-42A	234	282	10 3.5%	91 32.3%	162 57.4%	233 82.6%	274 97.2%	278 98.6%	279 98.9%	280 99.3%	290 99.3%	280 99.3%
XM-42A	235	387	83 21.4%	185 47.8%	242 62.5%	299 77.3%	359 92.8%	382 98.7%	387 100%	387 100%	387 100%	387 100%
XM-42A	236	316	67 21.2%	103 32.6%	128 40.5%	153 48.4%	231 73.1%	276 87.3%	309 97.8%	312 98.7%	312 98.7%	314 99.4%
XM-42A	237	284	41 14.4%	103 36.3%	131 46.1%	158 55.6%	207 72.9%	237 83.5%	266 93.7%	277 97.5%	279 98.2%	279 98.2%
XM-42A	238	193	10 5.2%	33 17.1%	50 25.9%	66 34.2%	115 59.6%	160 82.9%	180 93.3%	187 96.9%	190 98.4%	192 99.5%
XM-42A	240	305	82 26.9%	170 55.7%	211 69.2%	251 82.3%	294 96.4%	304 99.7%	304 99.7%	304 99.7%	304 99.7%	304 99.7%

Table III-10

ERROR DATA (ELEVATION)

Gun type	Trial No.	Total data points	Number of data points and percentage in each data interval milliradians										
			± 0.2	± 0.6	± 0.8	± 1.0	± 1.4	± 1.8	± 2.2	± 2.6	± 3.0	± 5.0	
ZU-23	74	358	0 0%	0 0%	8 2.2%	53 14.8%	161 45.0%	286 79.9%	355 99.2%	358 100%	358 100%	358 100%	
ZU-23	75	309	85 27.5%	197 63.8%	233 75.4%	276 89.3%	307 99.4%	309 100%	309 100%	309 100%	309 100%	309 100%	
ZU-23	77	91	1 1.1%	11 12.1%	38 41.8%	67 73.6%	89 97.8%	91 100%	91 100%	91 100%	91 100%	91 100%	
ZU-23	84	115	15 13.0%	53 46.1%	66 57.3%	78 67.8%	89 77.4%	97 84.4%	99 86.1%	104 90.4%	109 94.8%	113 98.3%	
ZU-23	86	427	172 40.3%	368 86.2%	394 92.3%	409 95.7%	424 99.3%	427 100%	427 100%	427 100%	427 100%	427 100%	
ZU-23	87	419	113 27.0%	214 51.1%	242 57.8%	300 71.6%	380 90.7%	415 99.0%	419 100%	419 100%	419 100%	419 100%	
ZU-23	88	304	2 0.66%	43 14.1%	77 25.3%	125 41.1%	274 90.1%	302 99.3%	304 100%	304 100%	304 100%	304 100%	
ZU-23	89	466	98 21.0%	253 54.3%	308 66.1%	367 78.8%	427 91.6%	465 99.8%	466 100%	466 100%	466 100%	466 100%	
ZU-23	98	124	17 13.7%	58 46.8%	77 62.1%	89 71.8%	116 93.5%	120 96.8%	121 97.6%	121 97.6%	122 98.4%	122 98.4%	
ZU-23	102	241	39 16.2%	67 27.8%	76 31.5%	98 40.7%	135 56.0%	217 90.0%	226 93.8%	229 95.0%	232 96.3%	239 99.2%	
ZU-23	103	102	5 4.9%	32 31.4%	53 52.0%	62 60.8%	81 79.4%	90 88.2%	95 93.1%	98 96.1%	100 98.0%	102 100%	
ZU-23	104	250	0 0%	9 3.6%	19 7.6%	30 12.0%	68 27.2%	155 62.0%	232 92.8%	247 98.8%	247 98.8%	250 100%	
S-60	73	272	59 21.7%	143 52.6%	190 69.9%	226 83.1%	270 99.3%	272 100%	272 100%	272 100%	272 100%	272 100%	

Table III-10 (cont'd)

Gun type	Trial No.	Total data points	Number of data points and percentage in each data interval									
			milliradians									
			± 0.2	± 0.6	± 0.8	± 1.0	± 1.4	± 1.8	± 2.2	± 2.6	± 3.0	± 5.0
S-60	74	342	29 8.5%	148 43.3%	198 57.9%	264 77.2%	342 100%	342 100%	342 100%	342 100%	342 100%	342 100%
S-60	75	433	237 54.7%	383 88.5%	420 97.0%	427 98.6%	433 100%	433 100%	433 100%	433 100%	433 100%	433 100%
S-60	86	291	128 44.0%	269 92.4%	279 95.9%	283 97.3%	286 98.3%	289 99.3%	289 99.3%	291 100%	291 100%	291 100%
S-60	87	366	182 49.7%	334 91.3%	353 96.4%	358 97.8%	363 99.2%	366 100%	366 100%	366 100%	366 100%	366 100%
S-60	88	437	128 29.3%	209 47.8%	386 88.3%	424 97.0%	436 99.8%	437 100%	437 100%	437 100%	437 100%	437 100%
S-60	89	347	87 25.1%	239 68.9%	300 86.5%	336 96.8%	346 99.7%	347 100%	347 100%	347 100%	347 100%	347 100%
S-60	90	157	43 27.4%	103 65.6%	128 81.5%	143 91.1%	154 98.1%	157 100%	157 100%	157 100%	157 100%	157 100%
S-60	91	181	109 60.2%	163 90.1%	175 96.7%	177 97.8%	178 98.3%	178 98.3%	178 98.3%	178 98.3%	178 98.3%	180 99.4%
S-60	99	110	75 68.2%	107 97.3%	108 98.2%	108 98.2%	108 98.2%	108 98.2%	108 98.2%	108 98.2%	108 98.2%	110 100%
XM-42A	221	85	32 37.6%	83 97.6%	84 98.8%	85 100%	85 100%	85 100%	85 100%	85 100%	85 100%	85 100%
XM-42A	222	347	246 70.9%	335 96.5%	339 97.7%	343 98.8%	344 99.1%	345 99.4%	345 99.4%	346 99.7%	346 99.7%	346 99.7%
XM-42A	224	372	221 59.4%	321 86.3%	345 92.7%	368 98.9%	371 99.7%	371 99.7%	371 99.7%	371 99.7%	371 99.7%	371 99.7%
XM-42A	225	325	272 83.7%	323 99.4%	324 99.7%	324 99.7%	324 99.7%	324 99.7%	324 99.7%	324 99.7%	324 99.7%	325 100%
XM-42A	226	366	91 24.9%	258 70.5%	310 84.7%	362 98.9%	365 99.7%	366 100%	366 100%	366 100%	366 100%	366 100%

Table III-10 (cont'd)

Gun type	Trial No.	Total data points	Number of data points and percentage in each data interval milliradians										
			<u>±0.2</u>	<u>±0.6</u>	<u>±0.8</u>	<u>±1.0</u>	<u>±1.4</u>	<u>±1.8</u>	<u>±2.2</u>	<u>±2.6</u>	<u>±3.0</u>	<u>±5.0</u>	
XM-42A	228	340	263 77.3%	330 97.1%	333 97.9%	335 98.5%	337 99.1%	338 99.4%	338 99.4%	338 99.4%	338 99.4%	338 99.4%	339 99.7%
XM-42A	230	269	105 39.0%	230 85.5%	242 90.0%	253 94.1%	254 94.4%	254 94.4%	254 94.4%	255 94.8%	255 94.8%	256 95.1%	260 96.6%
XM-42A	231	287	241 84.0%	274 95.5%	276 96.2%	278 96.9%	280 97.6%	280 97.6%	282 98.3%	283 98.6%	283 98.6%	283 98.6%	287 100%
XM-42A	232	352	233 63.4%	342 97.2%	345 98.0%	348 98.9%	350 99.4%	350 99.4%	350 99.4%	350 99.4%	350 99.4%	350 99.4%	350 99.4%
XM-42A	233	325	83 25.5%	196 60.3%	244 75.1%	292 89.8%	320 98.5%	320 98.5%	320 98.5%	320 98.5%	320 98.5%	320 98.5%	320 98.5%
XM-42A	234	282	135 47.9%	227 80.5%	247 87.6%	267 94.7%	274 97.2%	276 97.9%	277 98.2%	278 98.6%	278 98.6%	278 98.6%	278 98.6%
XM-42A	235	387	112 28.9%	223 57.6%	275 71.1%	327 84.5%	363 93.8%	383 99.0%	385 99.5%	385 99.5%	385 99.5%	385 99.5%	385 99.5%
XM-42A	236	316	145 45.9%	284 89.9%	294 93.0%	304 96.2%	306 96.8%	307 97.2%	309 97.8%	309 97.8%	309 97.8%	309 97.8%	312 98.7%
XM-42A	237	284	170 59.9%	250 88.0%	263 92.6%	276 97.2%	279 98.2%	280 98.6%	281 98.9%	282 99.3%	282 99.3%	282 99.3%	283 99.6%
XM-42A	238	193	56 29.0%	129 66.8%	153 79.3%	177 91.7%	186 96.4%	188 97.4%	188 97.4%	188 97.4%	188 97.4%	188 97.4%	189 97.9%
XM-42A	240	305	138 45.2%	256 83.9%	278 91.1%	300 98.4%	302 99.0%	304 99.7%	304 99.7%	304 99.7%	304 99.7%	304 99.7%	304 99.7%

three guns is 60.6 percent at ± 0.8 mrad, 73.5 percent at ± 1.0 mrad, and 87.3 percent at ± 1.4 mrad, as compared to elevation which is 77.3 percent at ± 0.8 mrad, 85.1 percent at ± 1.0 mrad, and 93.0 percent at ± 1.4 mrad.

c. Time of Fire Intervals

Concern was expressed over the instrumentation capability to measure accurately during the firing interval. Attempts to measure the instrumentation accuracy over time of fire were continuously frustrated by inability to obtain camera data during firing intervals, due to muzzle flash and gun vibration, and the crew's capability to track the target during these intervals. As a result, large interpolation intervals were required and questionable data resulted.

Five firing trials using the ZU-23 gun were recorded: trials 84, 98, 102, 103, and 104. A loss of track occurred after the first time of fire on each of these trials. This loss of camera track ranged from 0.4 second to 1.7 seconds. There were two trials (84 and 104) where only flash blanking and vibration precluded tracking capability. On the other three trials, the gun crews lost the target from the field of view in addition to flash blanking and vibration.

There were also five firing trials using the S-60 gun: trials 90, 91, 92, 93, and 99. Since the firing rate on the S-60 is approximately two rounds per second, the total tracking camera data lost was around 1-1/2 seconds due to flash blanking, severe vibration, dust and smoke. The instrumentation errors again indicate major fluctuations in the system but due to the inability to verify tracking capability, these errors were more than likely due to interpolation interval errors.

In summary, it appears from plots of azimuth and elevation errors that the major errors during firing intervals were due to the inability to compensate for crew tracking errors. Generally, the first round was recorded with tracking errors included. In the data around these first rounds, there appears to be no difference in errors before firing (nonfiring intervals) and the errors encountered after the first time of fire prior to losing the target in the flash.

5. PROBLEMS AND LIMITATIONS ENCOUNTERED

a. HITVAL I

Many problems and limitations were encountered which reduced the usable data to a small percentage of the trial data attempted. This report will not assess the failures but merely indicate the problems and limitations during data collection.

(1) Many problems arose concerning operation of the tow target. Initially the tow targets were not properly balanced and two tow targets were lost. Tow target fuses blew for undetermined reasons and the UHF receiver was found to be tuned to the wrong frequency during postflight failure checkout. The battery in the tow target also ran down. The cable cutter assembly malfunctioned twice in different areas. These problems caused either cancelled sorties or partially successful sorties.

(2) Partially successful sorties were generally attributed to flare failures on the tow target. A telemetry tone activated a stepping switch to allow current to activate the flares. Any break in this chain resulted in an inoperative flare. Numerous flares ignited sympathetically. This problem was solved by inserting asbestos shields between the flares. The tow target was seldom visible to the gun crew unless the flare was ignited. A few trials were successful without a flare, but data on these trials were of short duration. Digitized film data were marginal without the flare to highlight the tow target position.

(3) IRIG timing was critical to all the instrumentation since everything was based on time. Several times, low levels of IRIG timing signals were received by the instrumentation van and, as a result, synchronization dropouts occurred. The data collected during these periods were not usable.

(4) Laser power supply problems in the muzzle deflection system were uncovered during early testing on the ZU-23. Many periods of time synchronization dropouts occurred. The cause was traced to a loose solder joint in the laser power supply.

(5) Partial mission failures were occasionally attributable to incorrect film exposure. Several live missions were lost attempting to find the proper setting. IRIG time corresponding to each frame was recorded on the edge of the film. The diodes that provide the timing were incorrectly adjusted for some of the earlier missions.

(6) The camera field of view was initially designed at ± 15 mrad. Poor tracking results on the early missions indicated that this was definitely too small. Because of this problem, early ZU-23 trials (through SST-11) provided minimum data from the camera. The field of view was redesigned to approximately double the field of view for the ZU-23. The larger field of view was in effect after SST-19.

(7) After changeover to the S-60 gun, a failure was observed in the time of fire (TOF) pressure transducer. This eliminated useful data on two missions.

(8) The software used an interpolation scheme that required three data points before and after time of fire to interpolate the exact time of fire. The time synchronization dropouts mentioned in paragraphs (3) and (4) above played havoc with this scheme and data were available only through a data dump. Time of fire data were not determined when one of these six data points was missing. As a result of this problem and the field of view problem, no data were obtained over the firing periods for missions up to SST-26.

(9) WSMR radar systems were reported to have an angular precision of ± 0.3 mrad and ± 15 yards range precision. Radar tracking data depended on the position of the radar in relation to the track of the target. In translating the calculations to the RCS, one radar may utilize range data to determine RCS azimuth, whereas another radar may utilize azimuth data to determine RCS azimuth. Also, the TDU-25B tow target had two luneberg lenses physically separated by approximately 8 feet, one mounted in the nose and the other mounted in the tail. Depending on the radar site tracking and the geometry of the target in relation to the radar and RCS, differences in range and/or azimuth could occur. Consideration should be given to these factors.

(10) A minimum of three cinetheodolites were required for a valid solution. Any additional cinetheodolite stations provided more accurate data. These factors are also considered in determining valid trials.

(11) The tracking capability of the ZU-23 gun crews on the early missions was severely limited due to the out-of-balance condition of the barrel of the ZU-23. The equalizer spring was redesigned, but did not completely eliminate the balance problem. However, it closely approximated the original balance. The spring was substituted on SST-12.

(12) During early January 1974, the contractor, EG&G, reported that three errors caused problems in data reduction. These are discussed below.

(a) Target No. 7 Geodetic Error

The position of target No. 7 was encoded into the computer with a 1.4-meter error in elevation. This caused a maximum of 0.4-mrad error in the static data on that target. However, the alignment checks in the pre-trial alignment used target No. 7 as a guide to the pre- and posttrial heating errors. Since this target was used for a bias check in pre- and posttrial calibration, the error was also entered into all dynamic data in a complex format. It was difficult to determine where and how much the error affected all data collected. It was shown, however, that the maximum error was 0.4 mrad and was primarily in elevation. Since the same computer program was not used on the 57-mm system, the error was not introduced into any 57-mm data. Trials 35, 36, and 37 were rerun with this error eliminated and all later data reflect this correction.

(b) Superelevation Error

The computer program was written without a small, parallel superelevation calculation. This calculation was added later to the computer analysis program. The maximum azimuth error was 2 mrad at high elevation angles and reduced to zero at zero elevation. This error only affected azimuth and at 50 degrees elevation, it equated to approximately 1.4 mrad. Trials 2, 4, 7, and 8 listed in this report have some portion of this error included. These trials were not reaccomplished. All other trials have this error corrected.

(c) Digitized Film Calibration Factors

The calibration of the EG&G digitizer for the LOCAM camera film was accomplished by exposing film showing one of the fixed target poles. The zero position of the film was adjusted by the differences between the center of the target pole and the center of the film. On several trials this correction factor was applied backwards and instead of removing the errors, the errors were doubled. The errors that resulted varied from very small up to 5 mrad in azimuth and/or elevation planes. The calibrations were reaccomplished and the data rerun on the computer. Again, trials 2, 4, 7, and 8 were ignored, since they were small and inconclusive trials.

(13) The development of the film from the LOCAM cameras was of minimal quality until SST-20.

(a) The timing data were of poor quality when developed in the rapid processor. In several cases, the automatic reader made mistakes and in some cases could not read the diode light images. This caused timing problems and added labor to the digitization process.

(b) Calibration of the film was difficult due to the poor processing quality of the film. With the expanded field of view on the camera, this problem increased.

(14) The wandering mean problem concerned the nonstationary behavior of azimuth and elevation scoring system data. It was identified by the HITVAL staff and reviewed during the WSEG/IDA meeting on 22 April 1974. On 12 May 1974, a meeting was held at WSMR to organize an Air Force/Army Ad Hoc Committee to investigate this anomaly.

(a) The following areas were identified by the Ad Hoc Committee as areas requiring further investigation:

Range and instrumentation timing

Computer software

Gun and gun instrumentation

Cinetheodolite data

(b) The final Ad Hoc Committee report was presented to DDR&E, WSEG/IDA, and the HITVAL staff on 13 September 1974 (ref. 6). The committee proposed a dynamic comparison test of the gun instrumentation system to determine the accuracy of the gun encoders for both position and time while the system was in the tracking mode. Generally, the Ad Hoc Committee concluded that

The timing system was not the source of the problem.

There was no evidence to suspect the cinetheodolites, since analysis indicated that correlation between guns could be discounted.

Extensive questioning of WSMR personnel on the cinetheodolite calibration and software programs used to develop the cinetheodolite position data convinced the Ad Hoc Committee that the cinetheodolites were more accurate than the WSMR

guarantee of ± 1.5 meters. Also, analysis of the individual trials revealed the mean wandered in a manner not accountable by position error. It is conceivable that a small portion of the wandering mean error may be attributable to cinetheodolite position accuracy.

Gun calibrations are not repeatable and may introduce an unknown but appreciable measurement error. The committee recommended a complete calibration analysis.

The dynamic comparison test proposed by the committee and conducted by EG&G indicated that the gun instrumentation system was not directly responsible for the wandering mean problem. A dynamic comparison test was accomplished by EG&G to determine if the encoders lead or lag during rapid slew of the guns and if the wandering mean can be attributed to this fact. A test using a 100-frame-per-second camera mounted on the breech and boresighted to the tube was slewed at three speeds past several fixed target poles. At high slew rates the encoders appeared to lag the breech but at slow rates near the SST tracking rates, there appeared to be no lag or insignificant lag. The test procedures, results, and conclusions are contained in reference 7.

The HITVAL computer software was not analyzed because the committee did not possess the expertise or time to evaluate the software. The committee recommended that an independent verification and validation (V&V) of all applicable HITVAL software be accomplished.

(c) As a result of the Ad Hoc Committee's recommendation, it was determined that a comprehensive investigation of the wandering mean phenomenon should be performed by EG&G. EG&G concluded (ref. 8) that the HITVAL software and related analytical and geometrical calculations were correct, and were not a contributing factor to the wandering mean problem. Anomalies in azimuth and elevation exist outside the software area. These are attributable to mechanical aspects of the instrumentation, and to calibration nonrepeatability and subsequent procedures for selecting pre- or postcalibration. EG&G indicated that proper considerations applied to these anomalies will result in improvements in HITVAL I data, and evidence indicates that the wandering mean will be substantially reduced.

(d) EG&G was placed on contract in February 1975 to

Determine the exact cause of the wandering mean phenomenon and improve HITVAL I dynamic scoring test data.

Review the main test data from HITVAL I and determine the amount of data improvement which can be achieved.

If DDR&E and WSEG/IDA determine that the improvement is significant, EG&G will reprocess all HITVAL I main test data.

(e) The results of EG&G's efforts to improve HITVAL I data will be presented directly to DDR&E and WSEG/IDA at some future date.

b. HITVAL II

The utilization of an F-4 aircraft in place of the TDU-25 eliminated all of the tow target problems encountered in the HITVAL I scoring system test. Also, experience gained in approximately 1 year of preliminary and field testing was beneficial to the contractor and the test staff in decreasing instrumentation problems and in improving testing procedures. However beneficial the experience, problems still occurred which will be mentioned briefly.

(1) The first mission was invalid because the breech camera was not boresighted properly.

(2) In an effort to eliminate tracking problems encountered in HITVAL I, the gun crew attempted the first mission in mode I or full radar mode. To place the target in the field of view of the breech-mounted camera, the time of flight computer input was removed from the system, which effectively removed the elevation and lead angle. However, in this mode of operation, the system had an oscillatory tracking motion and lagged the target to such an extent that the target was out of the field of view of the breech camera for much of the mission. On the next mission, the gun crews were instructed to go to mode IV or manual track. In this mode, tracking was difficult, but adequate to obtain required data.

(3) For four trials, the last digit of the IRIG timing code on the film from the breech camera was unreadable with the automatic film digitizer. However, the data were salvaged by a manual processing procedure which was very time consuming.

REFERENCES

1. WSEG Report 191, "Design of Preliminary Tests, Probability of Hit by Anti-aircraft Guns," August 1972.
2. WSEG Report 197, "Design of a Field Test for Probability of Hit by Anti-aircraft guns," February 1973.
3. EG&G Report AL-1011, "Static Scoring Test: ZU-23," 7 November 1973.
4. EG&G Report AL-1011, "Static Scoring Test: S-60 (On-Carriage)," 8 February 1974.
5. EG&G Report AL-1145, "Static Scoring Test: XM-42A," 17 January 1975.
6. AFSWC/FTJ Letter, "Final Report of HITVAL Floating Mean Ad Hoc Group," 11 September 1974.
8. EG&G Report AL-1110, "Dynamic Comparison Test HITVAL I," 11 September 1974.
9. EG&G Report AL-1141, "Analytical Investigation of Wandering Mean Phenomenon HITVAL I," 10 December 1974.

BIBLIOGRAPHY

- "Addendum to Joint Test Plan for Joint Test for Probability of Hit by Anti-aircraft Guns (HITVAL), for HITVAL II," September 1974.
- "Joint Test Plan for Joint Test for Probability of Hit by Anti-aircraft Guns (HITVAL)," April 1974.
- WSEG Report 190, "Feasibility of a Test of Probability of Hit by Anti-aircraft Guns," August 1972.

APPENDIX I

DESCRIPTION OF TEST EQUIPMENT

This appendix describes the instrumentation used in the scoring system test. FPS-16 radar (or equivalent) and cinetheodolites were used to provide two independent sources of tracking data on the aerial target. The radar and cinetheodolite systems will not be described here because they are normal TSPI instrumentation.

A. GUN SENSORS

1. Various sensors were used to provide a measurement of physical quantities on the ZU-23, ZU-57, and XM-42A (figures 1-1 and 1-2). Optical encoders, manufactured by Baldwin Electronics, were used to sense basic shaft positions representing breech azimuth and elevation positions. They were coupled directly to the rotating centerline of the equipment.

2. Resolver/digitizer systems were used to project a digital representation of quantities measured on the gun systems. These quantities are the inputs to the on-carriage lead computing sights and the output angles representing gun sight position with respect to the gun mount. These quantities are normally geared to the resolver with appropriate gear ratio to provide the highest possible resolution while retaining adequate range to measure the full excursion on all values.

3. The third class of sensors was the pressure transducer system (figure 1-3) used to sense the passage of each round from each barrel. The pressure transducer was mounted near the muzzle and responded to the pressures in the barrel as the projectile exited.

4. The final class of sensors was a set of switches which were activated either by a gun function, such as a fire pedal depression, or by the gun controller. These switches provided means to sense the time of target detection, mask/unmask, and fire pedal depression.

5. Optical shaft position encoders are devices that convert an analog mechanical input, such as angular displacement, to a binary digital output through photoelectric means. Coupling the input shaft of the encoder to any

other shaft results in the analog input angle appearing in digitized form at the encoder output. The input shaft is rigidly connected to a glass disk upon which is a photographically engraved, binary, digital code pattern. Thus, a rotation of the input shaft by an angle, θ , relative to some reference, results in a rotation of the code pattern by the same angle about the same reference. A narrow light beam illuminates the code pattern along a radial line. A readout index is located on the side of the code disk away from the light source. The index, which is a narrow slit aperture, is radially aligned with respect to the code pattern, and views the illuminated radial segment of the disk. The light rays passing through the readout index can be controlled by the density of the photographically engraved code pattern. Very close to the index and directly behind it is a bank of photocells which detect the light being admitted through the index. Since the code is binary, two stable states are needed per digit, and the code pattern consists of combinations of either opaque or transparent segments. Thus, depending on whether an opaque or transparent segment is between the lamp and photocell through the readout slit, the corresponding photocell will be either dark or illuminated.

6. The resolver/digitizer encoding systems are designed for measuring mechanical motions of rotation and reporting the measured value in the form of parallel digital data to external data processing equipment. The basic encoding system consists of a transducer and an absolute encoder. The transducer is coupled to the driven element and produces low-frequency (400-Hz range) analog signals that are proportional to the angular position of the driven element. These signals are transmitted over system cabling to the absolute encoder. The absolute encoder contains the microelectronic circuits that process the transducer signals and produce the parallel digital data that are then supplied to the external data processing equipment.

B. TILT MEASUREMENT SYSTEM

1. Tilt of the gun base, in azimuth and elevation, is measured using optical techniques where a light beam is reflected off a mirror mounted on the gun base. The angle of the reflected beam is measured relative to the incident beam to determine the tilt angles (figure 1-4).

2. The measurement of pitch and roll is accomplished using a biaxial optical autocollimator (figure 1-5). A collimated light beam is projected horizontally and reflected 90° to a mirror mounted in a horizontal position on

the base of the gun. Tilt of the mirror mounted on the gun base alters the angle of the return beam to the autocollimator. These changes are detected electronically by an x-y transducer, and the position-to-analog voltage converter provides an analog signal representing position. The independent x and y analog signals out of the converter are digitized in an analog-to-digital converter. An external clock and trigger system provides sample commands to the A-D converters, and the digital data is entered into the buffer system.

3. Measurement of the yaw (i.e., the azimuth shift) of the gun mount is accomplished using a uniaxial autocollimator. The collimator/light source generates a vertical, triangular-shaped light beam which is reflected off a mirror positioned vertically on the gun base, and focused onto a horizontal photosensitive array. Changes in position of the reflecting mirror alters the position of the return light beam on the photosensitive array which is detected electronically. The signal is processed to determine yaw.

4. The system operates at 1 KHz and measures the roll, pitch, and yaw components of tilt up to ± 20 milliradians about each axis. Components of the system are

- a. Roll and pitch autocollimator head
- b. Yaw autocollimator head
- c. Control and power supply chassis
- d. Base plate assembly (with concrete pier under gun)
- e. 45° folding mirror assembly
- f. Gun reference mirrors
- g. Gun Reference mirror assembly mounts

C. PHOTOGRAPHIC CAMERAS

1. Photographic cameras are used in measuring the angular position of the target relative to the centerline of the gun barrel. The method employs 16-mm framing cameras manufactured by Red Lake Laboratories, Santa Clara, California (figure 1-6). The camera is capable of both pulsed operation (to 15 pulses per second), and continuous framing up to 200 frames per second. IRIG-A time is recorded on the edge of each frame. The cameras employ a 250-mm lens to provide the resolution necessary to meet the accuracy requirements.

2. The cameras used were LOCAM Model 164-5AC, a high-speed motion picture camera, full-frame, pin-registered, intermittent movement, 16-mm x 400-foot capacity. The 23-mm gun system had two LOCAM cameras, one mounted parallel to each barrel. The 57-mm system had only one camera mounted parallel to its barrel.

3. For the initial portion of the tests the cameras had a ± 15 -mrad field of view for both guns. The 23-mm gun crew were unable to track and hold the target in this small field of view, resulting in sparse camera tracking information. Subsequently, the field of view was increased to ± 27 mrad. The 57-mm tracking was better than the 23-mm; however, the field of view on the 57-mm gun was changed to ± 27 mrad so maximum data could be obtained.

4. Initial camera rates were 2 frames per second for the nonfire mode and 48 frames per second whenever the fire pedal was depressed. Data rates were insufficient for nonfire modes so an adjustment was made to allow more tracking film during the nonfiring periods. Frame rates increased to 24 frames per second by throwing a switch when the gun crew initiated target track.

D. MUZZLE DEFLECTION MEASUREMENT SYSTEM INSTRUMENTATION (not used on XM-42A)

1. Muzzle deflection was measured using a Reticon MC-500 series photodiode matrix array camera. The camera contained a self-scanned 50 x 50 matrix array of silicon photodiodes in the focal plane of the lens to provide a standard TV video output and sync signals. The video processing system accepts the standard TV signals from the camera and processes the data to produce digital x and y signals.

2. The system consisted of a HeNe laser light source modulated by means of a Pockel's cell. The system is, in effect, an autocollimator which measured absolute angular deviations of each barrel muzzle with respect to the boresight axis of the camera objective unit. Mirror and beam splitters were utilized in the camera objective box in such a manner as to make the Reticon camera and the transmitted light source all coaxial. The laser beam was returned to the camera objective by means of a muzzle-mounted mirror (figure 1-7).

3. This system was not used for the system scoring test but is required for the ballistics verification tests. Because of the later requirement this instrumentation was monitored during this portion of the test. During actual firing intervals, this system proved to be very unreliable. The Reticon matrix array recorded data sufficiently when small deflections (± 10 mrad) occurred.

During firing intervals, deflections of up to 20 to 40 mrad must be assumed. Angular rates of laser spot movement were also recorded up to 4 radians per second. Insufficient laser light during these high angular rate periods may have caused the photocell array to inaccurately register values. The system optics are being redesigned to nearly double the field of view.

4. The camera utilized a Reticon matrix array to achieve an image to electronic signal conversion. The design was 100 percent solid state, and achieved the conversion with the high geometric precision associated with photolithographic techniques by which the arrays are manufactured. All required processing was included in the camera to derive the (a) sample/hold video output; (b) x, y display drive signals; and (c) sync signaling end of frame..

5. The HeNe laser which provided the light source was a 2-mW laser, Coherent Radiation Model 30. Its wavelength was 6328 Å (red).

E. ROUND EXIT TIME MEASUREMENT INSTRUMENTATION

For the measurement of round exit time (time of fire) for each projectile during the system scoring test, a pressure transducer was mounted on the end of the barrel. A small hole was drilled to allow measurement of the barrel-pressure levels. As the projectile passed the pressure transducer opening prior to the barrel exit, the transducer recorded a large pressure spike. This signal was amplified, cut, and transmitted as the time of fire (TOF) indication. The TOF was recorded with IRIG A timing so that the millisecond of TOF was indicated.

F. GUN INTERFACE UNIT (GIU) (figure 1-8)

1. The gun interface unit provided the following elements for the HITVAL tests:

- a. Power for gun sensors
- b. Housing for tilt chassis
- c. Multiplexers for the gun data
- d. Sample rates to the gun sensors
- e. Synchronization of gun data to IRIG time
- f. Data conditioning for serial transmission to the computer interface unit.

2. The GIU was a 50-inch rack with four chassis. Two chassis contained power supplies for the gun sensors. The tilt system power supply and data conditioning were provided by a third chassis. The fourth chassis contained the data communications unit (DCU).

3. The DCU commanded all sensors to provide data in sync with IRIG time. The DCU received all data as parallel binary information.

4. The data was multiplexed and conditioned for serial transmission. Along with the gun data, the DCU read the BCD time of day from the IRIG input. The time of day information was multiplexed together with the gun data. The multiplexer also formatted the data for the computer. The formatted data were changed from parallel to serial and transmitted to the computer interface unit.

G. COMPUTER INTERFACE UNIT (CIU) (figure 1-9)

1. The computer interface unit accepted serial input data from the GIU and converted this data into parallel data for transfer to the computer. Also, the unit checked parity and signals parity errors to the computer in the recording and processing (R&P) van. The CIU displayed the status word generated by the GIU indicating gun identification and any other pertinent flag information. It also displayed a selected channel of data as chosen by the front panel "digi" switches, and provided an analog monitor output for this selected channel.

2. Major components of this subsystem are (a) optical isolators: high-speed optical isolators that provide ground isolation between the CIU and the GIU; (b) serial-parallel converter: this element accepts serial information from the GIU and converts it into parallel format required by the computer; (c) LED displays: two each 16-bit light emitting diode (LED) displays presented information in an easily read digital format; (d) digital-to-analog converter: this element converted digital data from any selected channel to analog form for monitoring during initial setup or trouble shooting.

H. DATA SYSTEM PROCESSOR INSTRUMENTATION

1. The heart of the data system processor instrumentation was the HP 2100A computer (figure 1-10). This computer offered the following elements as standard equipment in the main frame: (a) memory parity check; (b) memory protect; (c) extended arithmetic instructions; (d) optional floating point hardware.

2. The unit had 16,384 sixteen-bit words of memory. In addition, it had space in the main frame chassis for the field installation of 16,384 words of additional memory and floating point hardware. The processor provided a buffer between the different input/output data streams.

3. The instrumentation supporting the processor consisted of a disc with an average transfer rate of 50 words/sec and a total storage of greater than two million words.

4. The terminal was a standard ASR-33 teletype (figure 1-11) which operated at 10 characters per second. As a tool for data quality assurance and for presenting the test reports in a clear and concise manner, the system was equipped with a HP 7210A digital plotter. For the data output to be processed later on other computers, the processor had two (IBM) standard, seven-track computer-compatible magnetic tape transports which operated at a speed of 45 ips. The data were written with a byte density of 556 bites per inch.

I. HITVAL TEST SOFTWARE

1. The software required to support the scoring system test consisted of three major programs: (a) data acquisition program; (b) static engineering units program; and (c) dynamic engineering units program.

2. The data acquisition program acquired data from the CIU associated with each gun system. The data were written on the computer disc with identification information. The data collection was started and stopped manually by the computer operator. Following completion of a trial, the data were either (1) copied from disc to magnetic tape for subsequent processing or (2) processed by loading a processing program from the system disc.

3. For the static phase of the scoring system test, the static engineering units program was loaded directly following completion of data acquisition. This program converted all electronically measured data from the gun system into engineering units, computed the aligned sight vector from measurements, and compared it with the computed sight vector from surveyed data. This comparison yielded the errors of the gun pointing measurement system. During system checkout it was discovered that differential heating of the gun by the sun caused tilt leveling problems in the system. To solve these tilt problems, a computerized method of instrumentation alignment was developed. (See appendix 2, paragraph A.2.f(6).)

4. In the dynamic phase of the scoring system test, essentially the same programs were used to measure the gun pointing angles relative to a towed target instead of a fixed target pole. The dynamic engineering unit program read the raw gun data from the magnetic tape and converted it to an output tape containing the engineering units and time for all data. The data tape provided the necessary information for later processing and analysis of the dynamic performance of the gun measurement system.

5. All software programs were checked by preparing simulated data records. The simulated data were processed in the normal manner. The results were compared against manually calculated results to verify program performance.

J. RECORDING AND PROCESSING VAN

1. A recording and processing (R&P) van (figure 1-12) housed the processor equipment, facilities for the site controller and a small work/repair space for operating personnel. The floor plan of this van is shown in figure 1-13.

2. The van was a leased, office-type trailer (figure 1-13) with tandem axles. One end of this van provided an 8 x 15-foot data laboratory which housed the processor and all related digital equipment. An 8 x 5-foot section at the other end provided a control area for use by the site controller. The communications, timing, and range interface equipment required by the site controller was located in this area. The central 8 x 15-foot section was a work area.

3. The range provided an IRIG timing receiver and it was located at the front of the van. The IRIG receiver provided IRIG A timing to the van and through the van to the GIU for each gun system.

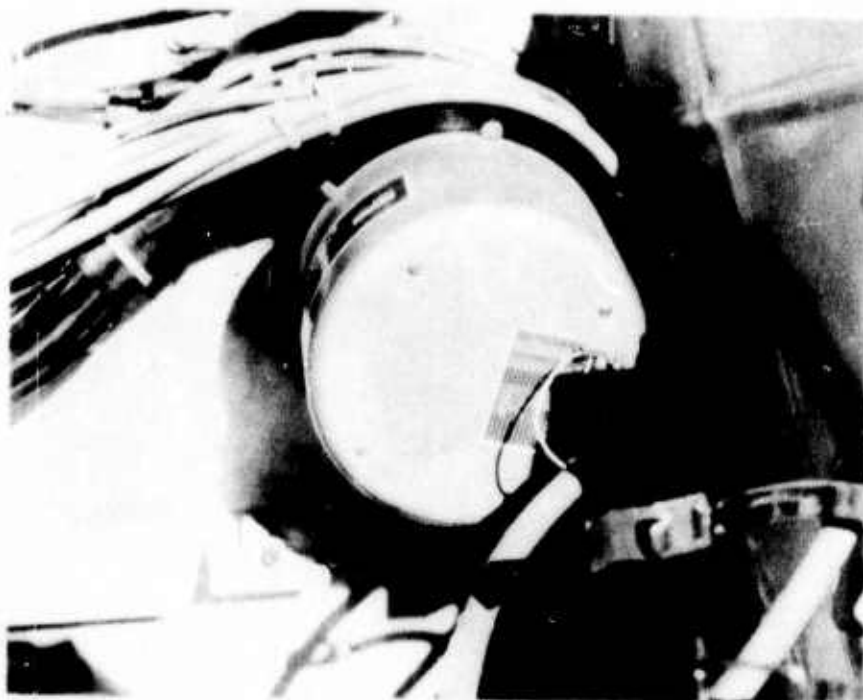

Figure 1-1. Elevation Optical Encoder on S-60 Gun

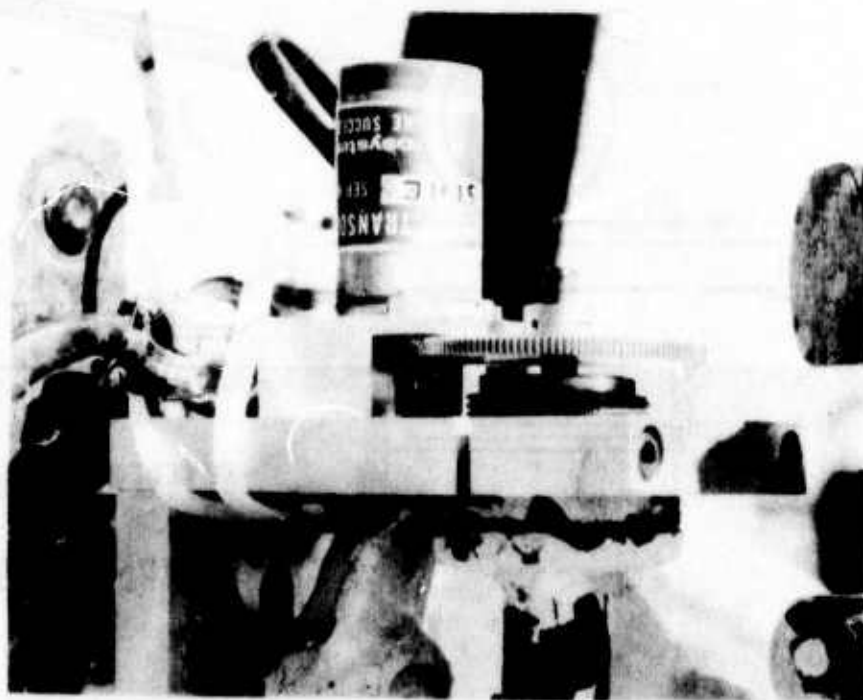

Figure 1-2. Typical Resolver on S-60 Gun

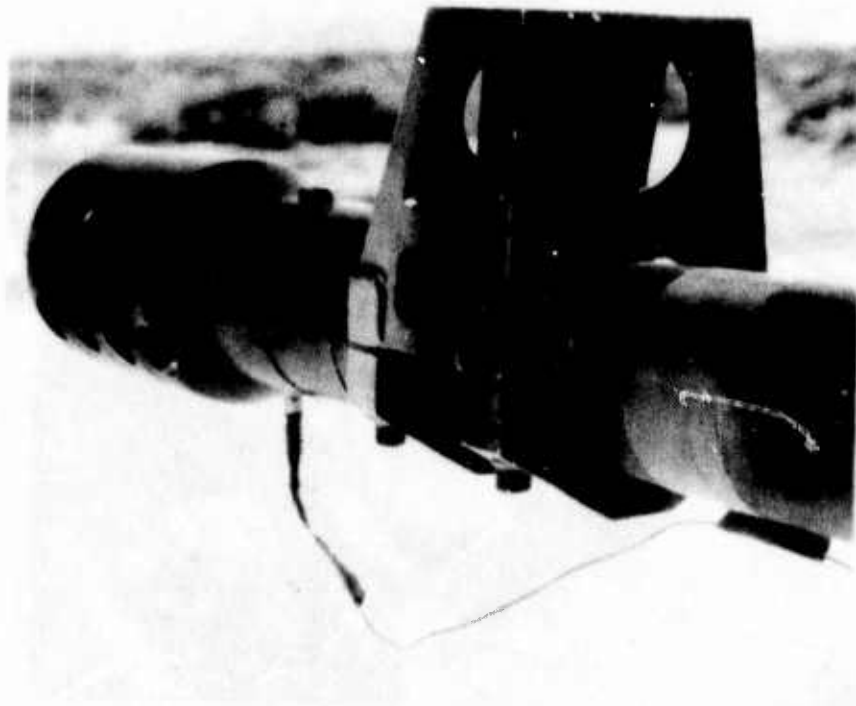

Figure 1-3. Pressure Transducer (S-60 Gun)

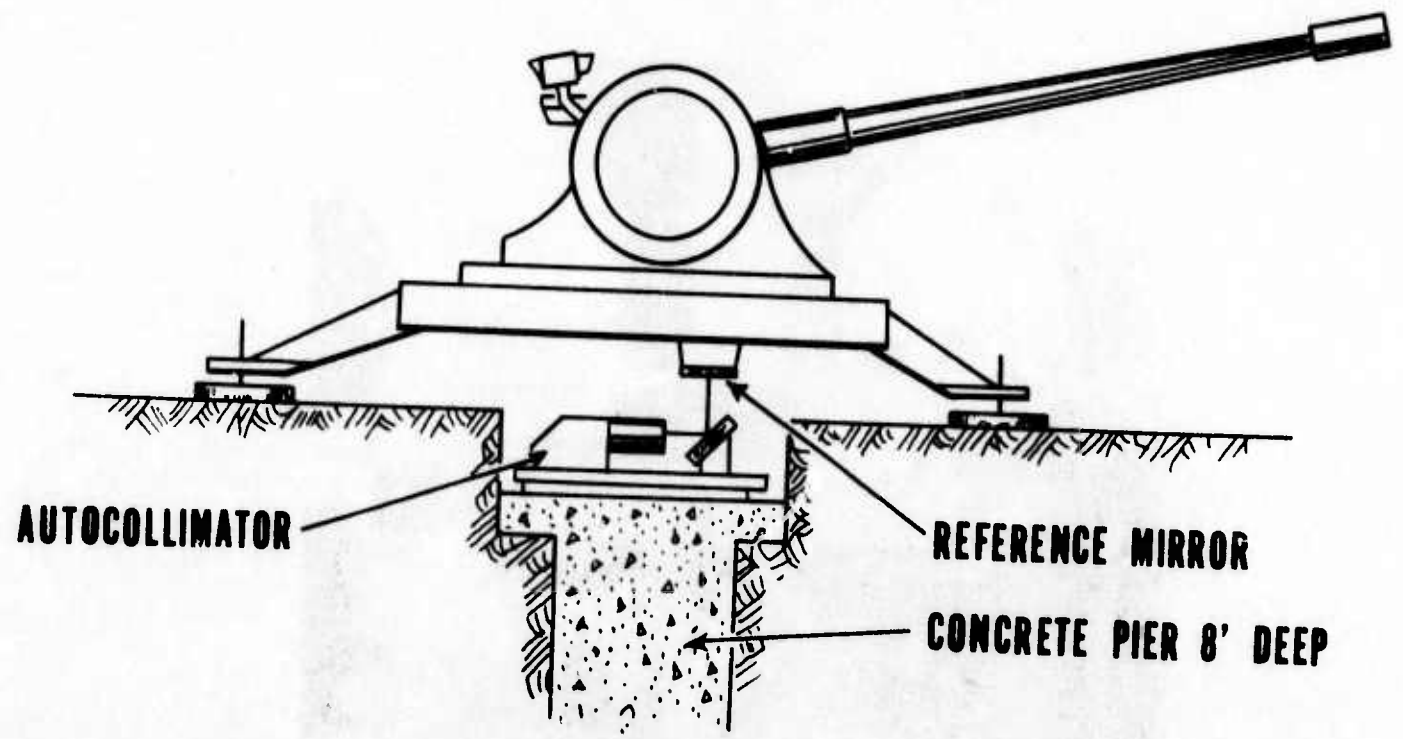

Figure 1-4. Drawing of Tilt Measurement System

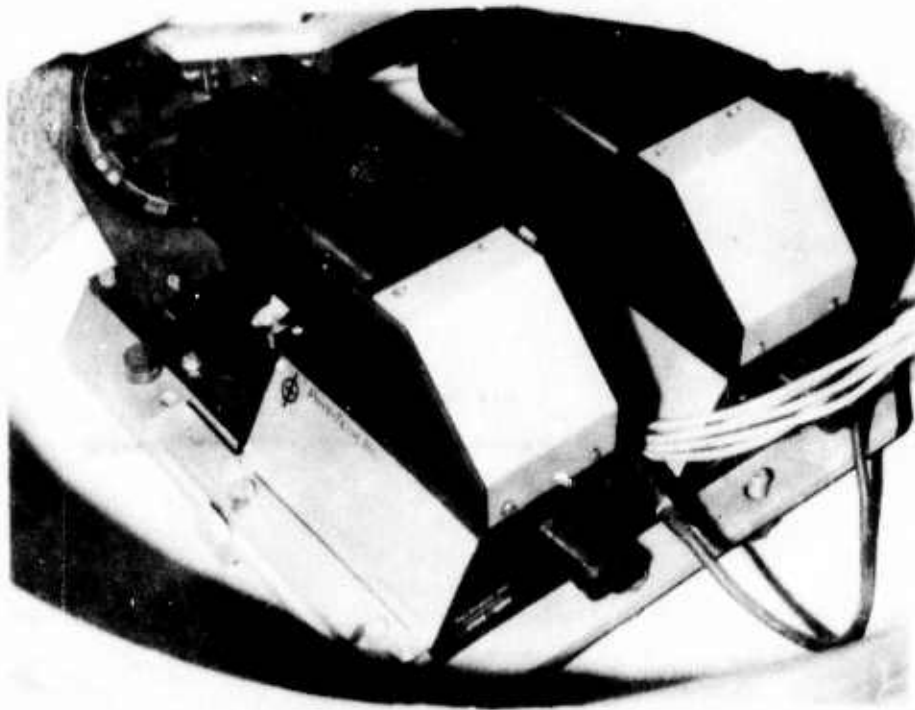

Figure 1-5. Optical Autocollimators

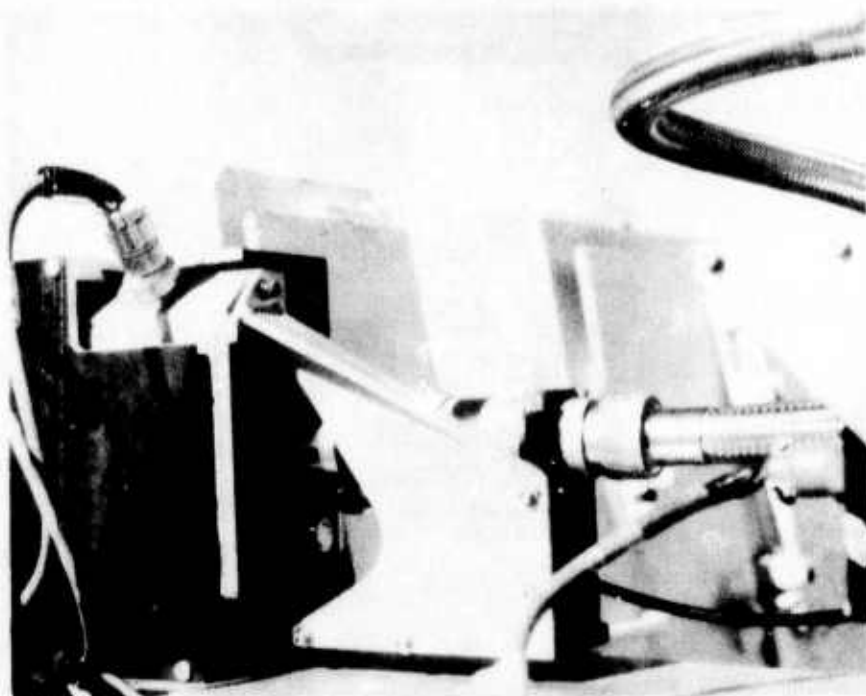

Figure 1-6. LOCAM Mounted on S-60 Gun

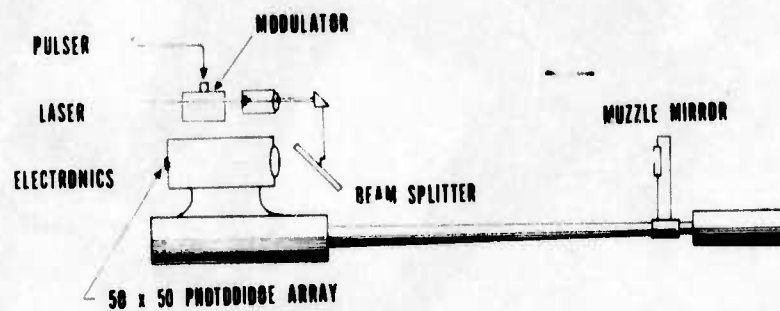

Figure 1-7. Muzzle Deflection System Diagram



Figure 1-8. Gun Interface Unit (GIU)

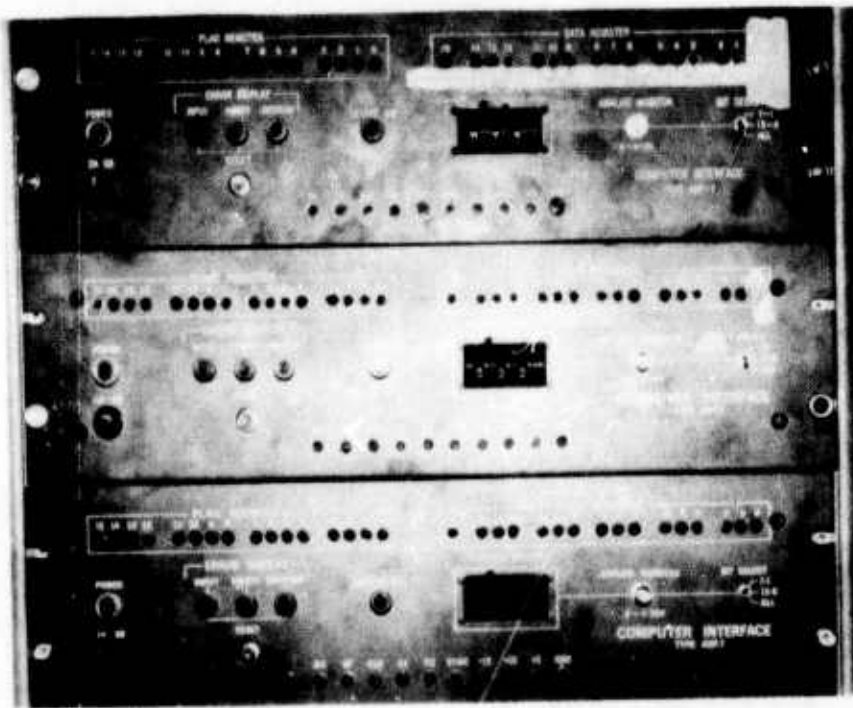

Figure 1-9. Computer Interface Unit (CIU)

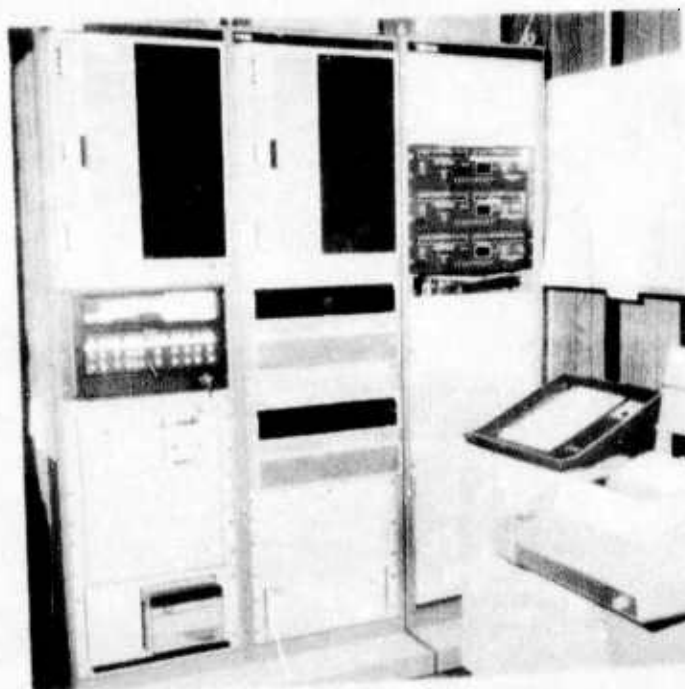

Figure 1-10. Hewlett Packard HP-2100A Computer (Left Cabinet)

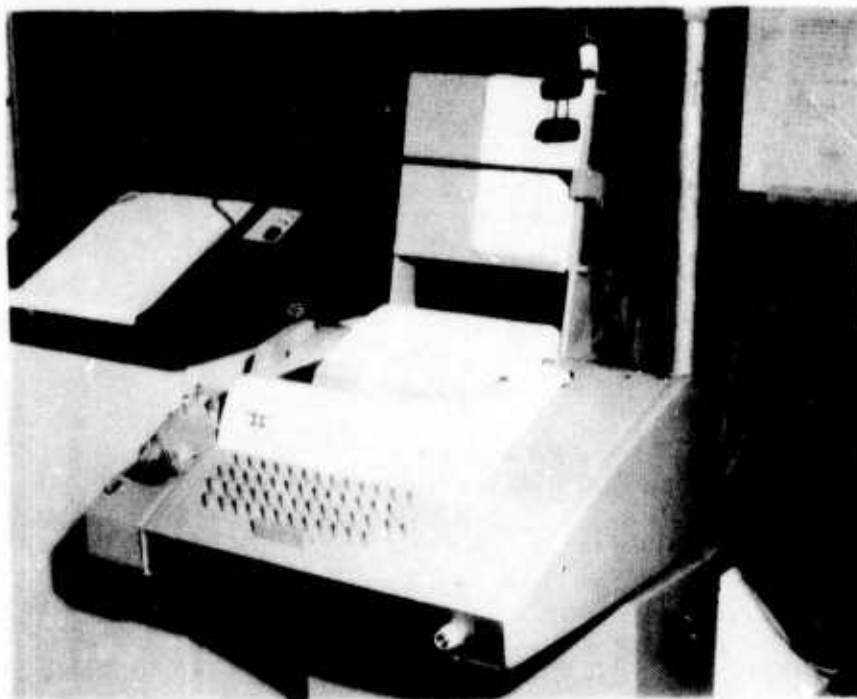

Figure 1-11. ASR-33 Teletype Unit

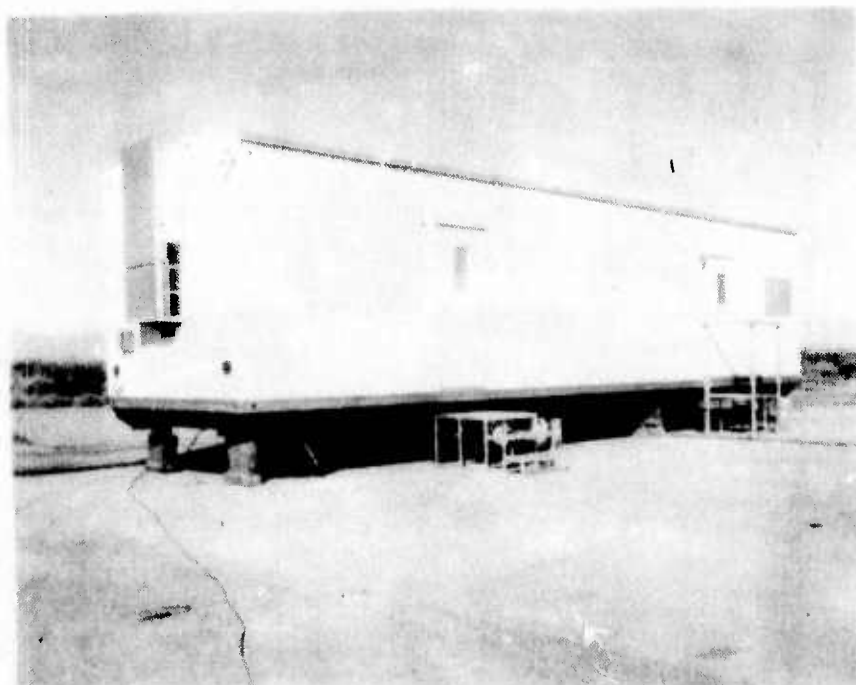

Figure 1-12. Recording and Processing Van

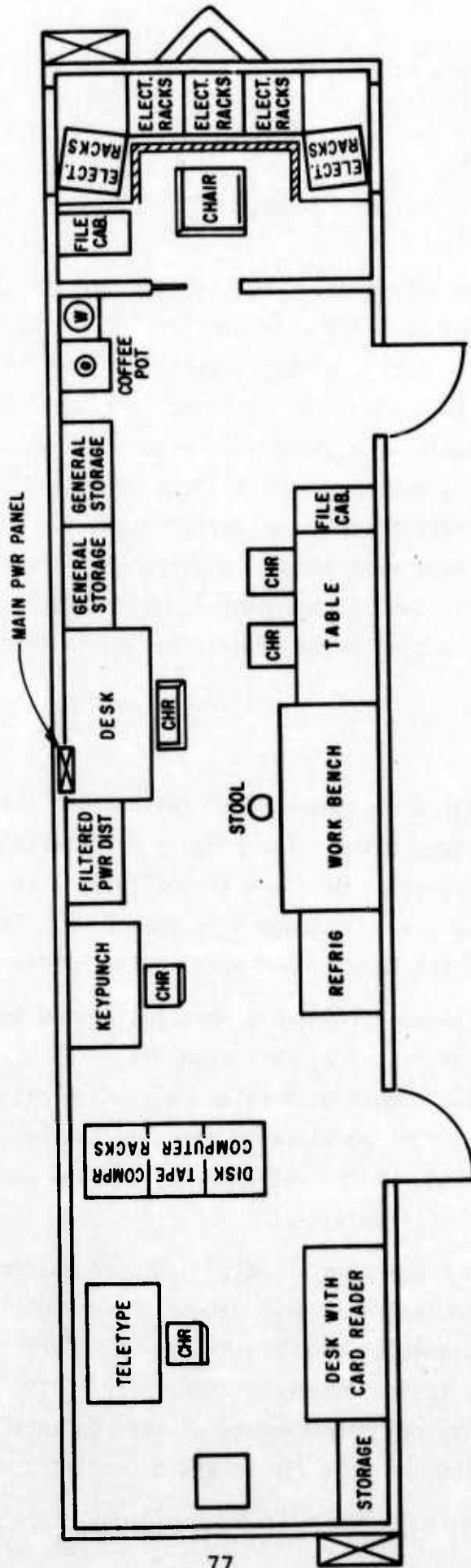

Figure 1-13. HITVAL Instrumentation Van (Recording and Processing Van)

APPENDIX 2
TEST APPROACH AND PROCEDURES

This appendix identifies the test approach for the system scoring test and defines the procedures used for each portion of the test. The system scoring test is basically two tests: a static test and a dynamic test. Each test was accomplished on the twin 23-mm and 57-mm on-carriage system and the XM-42A. Differences in procedure or approach for either gun will be identified in this appendix. In general, the three gun systems were handled identically. Static and dynamic tests differ in that the targets used for each test were different. Static test results were reported by EG&G reports "Static Scoring Test: ZU-23," "Static Scoring Test: S-60 (on-carriage)," and "Static Scoring Test: XM-42A," and much of the information recorded here was taken directly from these reports.

A. STATIC TESTS

1. Approach

a. The static test consisted of calibration checks of the gun-mounted portion of the instrumentation. The primary calibration reference was survey data providing the locations of fixed targets placed at various azimuths from the gun position at a given distance less than 2 km. Figure 2-1 shows the general placement of the targets and guns in the HITVAL test areas of WSMR.

b. All gun encoder/resolvers were calibrated and aligned by the procedures listed in paragraph A.2, this appendix. The static gun pointing angles were determined by the breech azimuth and elevation encoders, which measured the breech pointing angles relative to the gun chassis (base), and by the auto-collimators, which measured the roll, pitch, and yaw angles of the base relative to the ground (figure 2-2).

c. The breech was pointed at six surveyed targets, positioned in a circle of an approximate 2-km radius around the gun position, as shown in figure 2-1. The rectangular coordinates (x,y,z) of the gun's position and of the surveyed targets in the reference coordinate system (RCS) were known (table 2-1). The physical measurements of the gun that determined the position of the alignment telescope relative to the gun position were also known and

Table 2-1

TARGET AND GUN POSITIONS IN THE REFERENCE COORDINATE SYSTEM

<u>Target</u>	<u>x</u>	<u>y</u>	<u>z (meters)</u>
1	1573.856	-102.571	13.546
2	1136.616	2205.187	-1.160
21	1373.462	2094.780	-4.943
22	1309.269	2124.370	-1.794
3	-295.203	2064.355	11.466
4	-1554.696	1095.513	21.387
41	1554.864	1098.477	11.140
51	-2460.176	-215.887	78.990 (not used)
52	-2460.209	-215.890	153.300
5	-1611.855	-1860.113	28.029
6	-196.505	-1920.860	27.998
7	1486.949	-2035.050	39.174
Gun Position ZU-23	-5.604	128.491	1.590
Gun Position S-60	172.094	110.325	1.195
Gun Position XM-42A	-123.188	-144.813	3.015

are shown in figure 2-3 for the ZU-23 and figure 2-4 for the S-60 gun. A five-power rifle telescope attached to the gunner's quad plate and aligned parallel to the muzzle bore (the left muzzle bore on ZU-23) was used to lay the breech "on target."

d. The vector from the gun position to the target was rotated and translated to the alignment scope's position on the tilted gun frame by using the measured roll, pitch, and yaw angles and the physical dimensions of the gun. The azimuth and elevation angles between the alignment scope on the tilted gun frame and the surveyed targets were computed and compared to the encoder-measured azimuth and elevation angles. Thus, the errors in azimuth and elevation of the "gun-pointing measurement system" were determined. Figure 2-5 shows a systematic diagram of the measured parameters that determine the breech pointing errors. The static engineering unit program computes and prints out the determined pointing angle errors for each target sighting. Figure 2-6 is a sample computer printout of the static engineering unit program.

e. The inputs to the fire control systems were verified by positioning the input dials to known settings, activating the computer, printing out the encoder data in engineering units, and then manually checking the computer with the dial settings.

f. The tracking sight pointing angles were determined by four encoder measurements: (1) breech azimuth, (2) range carriage elevation, (3) sight elevation lead, and (4) sight traverse lead, which were geometrically transformed to yield the azimuth and elevation angles of the sight relative to the base. With the inputs to the fire control system at zero (which sets the tracking sight parallel to the breech), the azimuth and elevation angles between the tracking sight on the tilted gun frame and the surveyed targets were computed and compared to the measured angles geometrically transformed from the four encoder measurements. Thus, the errors in azimuth and elevation of the tracking angles were determined for zero lead angles on the tracking sight.

g. The tracking sight was further tested by inserting conditions into the fire control system that provided large lead angles between the tracking sight and the breech, and then laying the tracking sight "on target" and computing the azimuth and elevation errors. Eight lead angle conditions, at approximately 45-degree intervals in the 360-degree (vertical/horizontal) field of view of the tracking sight, were tested.

2. Alignment Procedure

The following is the procedure used to align the gun and accumulate the data for the system scoring tests. The procedures refer specifically to the ZU-23, but were similar for the S-60 gun and XM-42A.

a. Collimator Mounting Plate Alignment

(1) Installed mounting plate on concrete pier and cross-leveled to within 0.1 milliradian.

(2) Aligned locating gibs to range East-West azimuth to within 0.1 milliradian. This step required WSMR survey department support.

b. Collimator Installation

(1) Inspected autocollimators and the 45° turning mirror assembly to check that the Glyptal on the adjusting screws was intact.

(2) Installed autocollimators on mounting plate. Checked that all mating surfaces were clean. Clamped units in place and connected cables to electronic control chassis.

c. Gun Leveling

(1) Placed gun within $\pm 1/2$ inch of nominal position and orientation. The crew boresighted the gun and fired a settling burst.

(2) Elevated gun to desired elevation, locked the elevation mechanism, and installed a gunner's quadrant (inclinometer) on the gun.

(3) Traversed the gun through 360°, recording quadrant elevation at every 10° of azimuth. Plotted quadrant elevation against azimuth to evaluate leveling condition of the gun. Adjusted gun leveling pads, as required, and continued this process until quadrant elevation versus azimuth showed only azimuth axis runout; i.e., there remained no "DC" tilt term.

d. The roller path waviness (shaft runout) of the azimuth axis was significant, and calibration correction factors were developed and applied to the elevation angles in the computer program.

e. Mirror Installation

(1) Inspected mirror holding fixture for integrity of laboratory-set adjustments.

(2) Installed mirror holding fixture on gun. Adjusted orientation of the mirror fixture with respect to the gun until the autocollimators read zero on all three axes. Locked the mirror fixture adjustment carefully.

f. Gun Pointing Angles

The gunner's quadrant base on the gun breech (on the ZU-23, the gun cradle) was used to determine the axis of the gun. An alignment telescope and the objective lenses of the reticon and LOCAM cameras were firmly attached to the gunner's quadrant base. The alignment scope was optically aligned parallel to the left muzzle bore by sighting on the target board used by the gun crew to boresight the gun. The left breech was fixed to the gun cradle and was used as a reference by the gun crew to boresight the gun. The optical centerline of the alignment scope was defined as the centerline of the breech. To electrically align the breech azimuth and elevation encoders,

(1) Placed an inclinometer on the gunner's quadrant base on the gun cradle and set the breech elevation to zero. Electrically aligned the elevation encoder to 4096 counts (zero counts was downward).

(2) Laid the alignment scope on a surveyed target at a distance of approximately 1 km and aligned the azimuth encoder.

(3) Verified the elevation encoder reading.

(4) Laid the alignment scope on five other targets at approximately equally spaced azimuths and verified the azimuth and elevation encoder readings. If the encoders' readings showed a consistent one-sided error, the encoders were reset until the errors assumed a symmetrical distribution around zero.

(5) Since the roller path waviness of the azimuth axis was significant, the application of calibration correction factors was required.

(6) During the system checkout it was discovered that differential heating had a significant effect on the alignment system. In addition to the calibration correction factors used in the computer program for roll out errors, another correction factor was included for differential heating of the gun system. This was accomplished using the following procedure. Prior to a test trial, the breech was aligned to targets 2, 4, 5, and 7, and measurement errors were computed. The errors were fed back into the computer program so that the bias of the measured parameter was adjusted by the measured errors. In this manner the system was realigned with the prevailing pretrial conditions.

g. Muzzle Deflection Angles (not applicable to XM-42A)

(1) The muzzle measurement system is, in effect, an autocollimator which measures absolute angular differences between the boresight axis of the camera objective unit and the centerline of the barrel muzzle.

(2) The axis of the camera objective unit was defined as the boresight axis of the gun as indicated by the azimuth and elevation encoders. Alignment of the muzzle measurement system consisted entirely of aligning the muzzle mounted mirror such that the normal to the mirror surface was parallel to the centerline of the muzzle. A muzzle plug alignment device was designed which allowed field alignment of the muzzle mirror with no necessity for the barrel being initially straight or undeflected. The alignment concept is depicted in figure 2-7.

(3) The muzzle plug tool was laboratory aligned such that its optical axis was parallel to the centerline of the plug. The plug itself was designed to expand to a tight fit inside the barrel by means of an external knob. Once the plug was installed, rotated into the boresight axis of the gun, and expanded for a tight fit, a direct measure of barrel deflection was immediately available by means of the reticon system or the coaxially mounted photographic system.

(4) Alignment of the muzzle mirror consisted of angularly adjusting the muzzle mirror such that the return beam from this mirror was parallel to the return beam from the muzzle alignment tool. This was viewed directly through the camera objective unit, by means of a CRT monitor driven by the reticon system, or through a photographic camera using the focusing and alignment tool.

h. Tracking Angles

(1) The reflex sight was aligned parallel to the axis of the alignment scope on the breech. Targets were drawn on a target board at the physical dimensions of the vertical and horizontal separation between the breech axis and the centerline of the reflex sight. The Breech axis was set at zero elevation (inclinometer reading). The target board was positioned at approximately 100 meters until the cross-lines of the alignment scope on the breech axis were on target. The reflex sight was laid on target by adjusting the inputs to the fire control system.

(2) The elevation lead angle and the traverse lead angles were electrically aligned to mid-range 22.5° (1024 counts). The inclinometer was set on the range carriage using the range carriage adapter block and the initial range carriage angle recorded. To properly track traversely, the reflex sight should be physically aligned such that the line of sight is perpendicular to the traverse lead axis. Using a specially designed test fixture and an inclinometer, the inclination from vertical of the traverse lead axis was measured. If the angular error was significant, it was applied to the geometrical transformation used to transform the measured angles to the tracking azimuth and elevation angles. The inclinometer was set on the range carriage and the breech depressed until the range carriage was level and the range carriage resolver was electrically aligned to 410 counts.

(3) The breech was depressed until it bottomed out and the inclinometer and encoder readings of the breech elevation and range carriage elevation were recorded. This was repeated at approximately 10° intervals, including the angles where the breech topped out.

(4) The reflex sight rotates on a gimbal that is not orthogonal to the breech axis. Thus the traverse lead and elevation lead angles, which are the measured angles, must be transformed through a rotation of the coordinate axis to obtain the tracking angles in azimuth and elevation. The angle between the elevation lead axis and the range carriage axis (in the breech elevation plane) were optically measured by the following procedure.

(a) A target board was placed approximately level to the gun and at 100 meters from the gun. A target cross was drawn on the board and the breech alignment scope was laid on it. The azimuth and elevation axes were locked.

(b) An inclinometer was placed on the range carriage and the range carriage elevation recorded.

(c) The gimbal yoke was removed from the elevation lead axis of the reflex sight and a mirror normal to the axis (a specially designed test fixture) was installed.

(d) An autocollimator theodolite was placed normal to the mirror, such that the elevation lead axis was extended to the vertical axis of the theodolite.

(e) The normal distance was measured between the vertical axis of the theodolite and the elevation plane of the breech.

(f) A vertical line was drawn on the target board coincident with the horizontal distance measured in step (e).

(g) The elevation angle of the elevation lead axis was measured by turning the theodolite in elevation to a level position.

(h) The horizontal angle was measured by turning the theodolite in azimuth until it was on the vertical line drawn on the target board. The three measured angles (the elevation angle of the elevation lead axis, the azimuth measured by theodolite, and the range carriage inclinometer reading) were used to compute the angle between the elevation lead axis and the range carriage axis.

i. Fire Control System Inputs

The hand-computer input measurements were accomplished using resolvers coupled directly to the input shafts. The aircraft course was measured directly with a 1:1 geared resolver providing a full count of 2048 binary counts representing 360°. The resolver was electrically zeroed at zero degrees course angle and the count increased with counterclockwise rotation. Target climb/dive was measured using a resolver coupled with a 2:1 gear ratio to the climb/dive dial. This provided a total count of 2048 binary counts at 90° climb and zero counts at 90° dive. The resolver was electrically aligned to zero counts.

j. Resolution of the various sensing systems for the ZU-23 is indicated in table 2-2.

3. Test Procedure

a. Breech Pointing Angles

Each of six surveyed targets (numbers 1, 2, 3, 4, 5, 7) was sighted twice for each of three tilt modes, for a total of 36 sightings. These tilt modes included (1) a zero tilt condition (roll and pitch at approximately zero), (2) a positive tilt condition (roll and pitch at approximately +10 milliradian), and (3) a negative tilt condition (roll and pitch at approximately -10 milliradian). During each sighting, 36 frames of data were taken at a 10-per-second rate, and the mean errors in the azimuth and elevation angles of the breech

Table 2-2

RESOLUTION OF ANGLE MEASUREMENT TRANSDUCERS (ZU-23)

<u>Measurement</u>	<u>Instrument</u>	<u>Gear Ratio</u>	<u>Resolution (mrad or meters)</u>
Base roll, α	autocollimator	--	0.333
Base pitch, β	autocollimator	--	0.333
Base yaw, γ	autocollimator	--	0.333
Breech azimuth, θ_{bb}	14-bit encoder	1:1	0.383
Breech elevation, ϕ_{bb}	14-bit resolver	7.988:1	0.384
Range carriage ele. ψ	11-bit resolver	3.2:1	0.959
Sight elevation lead, η	11-bit resolver	4.0:1	0.767
Sight traverse lead, ζ	11-bit resolver	4.0:1	0.767
Target velocity, U	11-bit resolver	1:1	0.176
Target course, χ	11-bit resolver	1:1	3.067
Target climb/dive, δ	11-bit resolver	2:1	1.534
Target range, R	11-bit resolver	1:1	nonlinear 6.36 m at 3300 m

were calculated. The mean error and standard deviation were then computed for the 36 sightings. See section II for data summaries.

b. Fire Control Inputs

To verify that the fire control settings could be measured within certain specified accuracies by the data gathering system, five sets of static data were obtained with various fire control inputs. Results are shown in table 2-3.

c. Sight Tracking Angles

(1) A test of the sight pointing angles was performed at the same time as the breech pointing angles (paragraph A.3.a above), with the fire control system set at zero, which positions the reflex sight parallel to the breech.

Table 2-3
FIRE CONTROL INPUT ERRORS (ZU-23)

<u>Parameter</u>	<u>Setting</u>	<u>Measurement</u>	<u>Error</u>	<u>Specified accuracy</u>	<u>Mean error</u>	<u>Standard deviation</u>
Target velocity (m/sec)	0	0.2	-0.2	1.0		
	50	50.1	-0.1			
	100	99.6	0.4			
	200	199.5	0.5		0.12	0.31
	300	300.0	0.0			
Course angle	0.0	6.28012 rad	3.07 mrad	4.0 mrad		
	45°	0.78233	3.07			
	90°	1.56773	3.07			
	180°	3.13852	3.07			
	270°	4.71546	-3.07		1.8 mrad	0.27 mrad
Climb/dive	-45°	-0.78693 rad	1.53 mrad	4.0 mrad		
	-20°	-0.35128	2.22			
	0°	-0.00153	1.53			
	+30°	0.52616	-2.56		0.4 mrad	2.0 mrad
	+68°	1.04771	-0.51			
Range (meters)	0	0	0	50		
	500	500	0			
	1000	988	12			
	1200	1213	-13		2	10.2
	2000	1989	11			

(2) For this test as in the breech pointing angle test, a total of 36 sightings were made. During each sighting, 36 frames of data were taken at a 10-per-second rate, and the mean errors in tracking sight azimuth and elevation were computed. The mean error and standard deviation were then computed for the 36 sightings.

(3) To further exercise the tracking sight at large lead angles, the sight was pointed at target 3, with the fire control inputs and breech pointing angles relative to the target as shown in tables 2-4 and 2-5. The best target to use for this exercise was target 52, the Met tower. However, there was an error in the geodetic survey on this target, so it was not used. Target 3, the laser target, was the next best target visible from the guns, so it was used. Tables 2-4 and 2-5 also indicate in the columns labeled breech azimuth and breech elevation, the variations between the reflex sight and the breech, when maximum values of the gun computer were exercised.

B. DYNAMIC TESTS

1. Approach

a. The dynamic test consisted of calibration checks of the gun mounted portion of the scoring system instrumentation. The static tests mentioned in paragraph A above have several limitations.

(1) The first limitation is the static tests compare instrumentation results at only six low elevation targets.

(2) The second limitation is the lack of movement of these targets.

(3) The third limitation is the lack of a final check out of the tracking cameras. During static tests they are not used, and the film digitizing and processing introduces more of the field test procedures.

(4) The fourth limitation is a lack of testing in an actual firing mode. No rounds are fired during static testing and the field test will have firing.

(5) A fifth limitation is that constant use of a small number of specially selected static targets throughout varying atmospheric conditions and instrumentation configurations created special calibration and data compensation routines that forced the data to appear very accurate when compared to the known position of these targets. However, when the system was operated in

Table 2-4

FIRE CONTROL INPUTS AND REFLEX SIGHT ERRORS RELATIVE TO TARGET (ZU-23)

Target velocity v (m/sec)	Target course χ (deg)	Climb/ dive δ (deg)	Range R (m)	Sight AZ error $\Delta\theta_{sb}$ (mrad)	Sight EL error $\Delta\phi_{sb}$ (mrad)	Lead angles	
						Breech azimuth $\Delta\theta_{bb}$ (deg)	Breech elevation $\Delta\phi_{bb}$ (deg)
300.4	321.4	-17.2	80.0	0.1	0.0	-0.05	5.46
300.5	321.4	20.1	88.0	-3.1	1.7	-0.06	-6.62
300.4	51.0	0.0	0.0	-0.9	-0.6	18.77	-0.04
300.4	213.1	0.0	0.0	-1.3	0.1	-18.00	-0.05
300.2	30.9	-14.9	583.0	1.6	-0.7	20.75	5.44
303.0	169.0	-14.9	415.0	-0.2	-0.4	-20.77	5.43
300.4	30.4	20.1	432.0	0.6	-2.0	19.96	-7.92
300.4	169.6	21.2	435.0	-1.3	-2.0	-20.13	-8.37
Mean error:				-0.56	-0.49		
Standard deviation:				1.43	1.20		

Table 2-5

FIRE CONTROL INPUTS AND REFLEX SIGHT ERRORS RELATIVE TO TARGET (S-60 GUN)

Target velocity v (m/sec)	Target course χ (deg)	Climb/ dive δ (deg)	Range R (m)	Sight AZ error $\Delta\theta_{sb}$ (mrad)	Sight EL error $\Delta\phi_{sb}$ (mrad)	Lead angles	
						Breech azimuth $\Delta\theta_{bb}$ (deg)	Breech elevation $\Delta\phi_{bb}$ (deg)
317.5	170.7	81.9	1606	0.3	0.5	1.2	-21.2
317.3	175.3	4.6	1264	0.1	0.6	3.0	4.1
317.6	102.6	0.0	1967	1.0	-1.1	22.0	-0.8
317.6	102.6	6.3	1953	1.8	1.4	21.3	4.8
317.8	87.1	-81.4	1836	0.1	-0.1	8.1	-21.7
317.6	253.8	-81.9	1793	-1.0	2.1	-7.9	-21.5
317.8	237.2	0.0	1736	-0.6	3.8	-21.9	-0.3
317.8	237.2	6.3	1730	-0.6	3.2	-21.1	5.3
Mean error:				0.138	0.950		
Standard deviation:				0.920	1.915		

a dynamic mode and the full span of coverage of the instrumentation was exercised, the special calibration and data compensation routines were normally less applicable. The absolute value of these inaccuracies cannot be estimated, hence, empirical test data were needed.

b. Since the instrumentation and preliminary calibrations were the same as on the static tests, the dynamic test description deals primarily with the differences between static and dynamic tests. The areas to be discussed are the test concept, the tow target, and the tracking camera.

2. The Concept

a. The original concept was to analyze the hemisphere around the gun site with a 4-km radius. This hemisphere would check all the azimuths and elevations possible. The concept gradually evolved to the requirement for the six nonfiring passes or trials and two firing trials on HITVAL I. For HITVAL II the firing trials were deleted. These trials would be against a target flown at high, medium, and low altitudes and various ranges from the guns. Because of the instrumentation cable booms and range safety limitations, tracks to the south of the site were excluded. The firing sector was limited to a 40° sector from 020° true to 060° true. In early testing the gun crews were unable to maintain track of the target in the field of view of the camera. The camera optics were modified to provide a larger field of view. Tracking errors were subtracted from range positioning of the target to align gun instrumentation azimuth and elevation with time space position indication (TSPI) azimuth and elevation. The differences of TSPI and gun azimuths and elevations are errors in (1) calculations, (2) range target position inaccuracies, and (3) gun instrumentation errors. The error budget for these three items is 0.8 mrad (table I-1).

b. The dynamic test outlined above does not provide a direct means of isolating the source of any error that is detected. This limitation will be partly overcome by the static test of gun instrumentation and by a comparison of the TSPI tracking data from the two sources (radar and cinetheodolites) as well as some maximum estimates on target position errors as derived from cinetheodolite calculations.

3. The Target

a. HITVAL I

The tow target selected was the TDU-25B target. This vehicle is approximately 10 feet long, 10 inches in diameter, with a 3-foot vertical fin and two 1-foot horizontal fins at the top and bottom of the vertical fin. The tail section is mounted with four TAU-56B flares. The target was towed by a Navy A-4 aircraft at speeds varying from 250 to 300 KTAS. The flares were fired electrically by a telemetry tone transmitted to the tow vehicle in flight. The radar augmentation system was two luneburg lenses mounted fore and aft to allow for radar tracking by MPS-36/FPS-16 tracking radars. The flare provided a point source for gun crews, cinetheodolite film, and LOCAM camera film. The tow reel used allowed 26,000 feet of cable to be reeled out, but in this test a maximum of 11,000 feet was used. The tow target passed by the gun site from 1 to 3 km ground distance and from 1000 to 5500 feet AGL. This exercised the gun from 5 to 60° elevation. Azimuth pointing directions were possible from 200 to 360° true and from 360 to 160° true.

b. HITVAL II

The target used on the HITVAL II test was an F-4 aircraft with all data reduced to the nose of the aircraft. The gun was exercised in essentially the same areas as HITVAL I.

4. The LOCAM Camera

The gun LOCAM camera is discussed in the instrumentation section (appendix 1) of this report. This section discusses the use of the camera. The camera was mounted on the breech support and boresighted with the tube and provided a measurement of the angles between the centerline of the bore (measured at the breech) and the actual line of sight to the target. The measured angles of the gun base relative to the RCS and the gun breech relative to the base were combined to obtain a "gun estimate" of the pointing direction of the breech. Both the radar data and the cinetheodolite data were used separately with the LOCAM camera data and survey data to compute "TSPI estimates" of the pointing direction of the breech. The "gun estimate" and the "TSPI estimates" were compared and the differences analyzed statistically and nonparametrically.

5. Procedure

a. Prior to the start of a trial, the aircraft arrived in the WSMR area in a holding (orbit) position. The test conductor located in Building 300, through radio contact, ensured the aircraft was ready. The site controller, a member of the test staff located in the EG&G recording and processing van, maintained contact with the EG&G site supervisor and with each of the gun controllers. He ensured that the guns and crews were ready, and that the instrumentation was functioning properly and had been checked out. The test conductor contacted range personnel for necessary operational range support systems. When all systems were ready, the test conductor ordered the aircraft to commence its pass. For HITVAL I, a flare was ignited on each inbound pass to ensure complete flare coverage of the pass.

b. Aircrews and gun crews were told the range, the attack heading, and the altitude beforehand. The pilot maneuvered to establish these test parameters. The gun crews acquired and engaged the tow target as it entered the gun envelope. After clearance by the test conductor, the aircraft exited the test area and began to establish the test parameters for the next pass.

c. After a trial, the gun crews cleared their weapons and secured the ammunition required for the next trial. The gun controllers checked that all guns were clear, then completed the log sheet for that trial. The EG&G site supervisor ensured that the instrumentation functioned properly and reported his status to the site controller (figure 2-8). Normally, a quality check was performed to determine the validity of the pass from the instrumentation standpoint. The site controller checked with the gun controllers to ensure that all guns were successfully fired (live fire trials). This status report was forwarded to the test conductor. The WSMR officer checked with range personnel to verify that data were obtained from all range instrumentation and reported this to the test conductor. The test conductor then decided whether the trial must be reaccomplished.

d. After the completion of all trials, the aircraft was released to return to base and the mission was complete.

e. Postcalibration checks were accomplished and the gun tape prepared using the dynamic engineering unit program (appendix 1).

f. LOCAM film was developed, shipped to EG&G, digitized and forwarded in tape format to the Air Force Weapons Laboratory (AFWL) for analysis (appendix 3 for data flow).

g. TSPI tapes (cinetheodolite/radar), gun tapes, and digital camera tapes were analyzed to determine consolidated error.

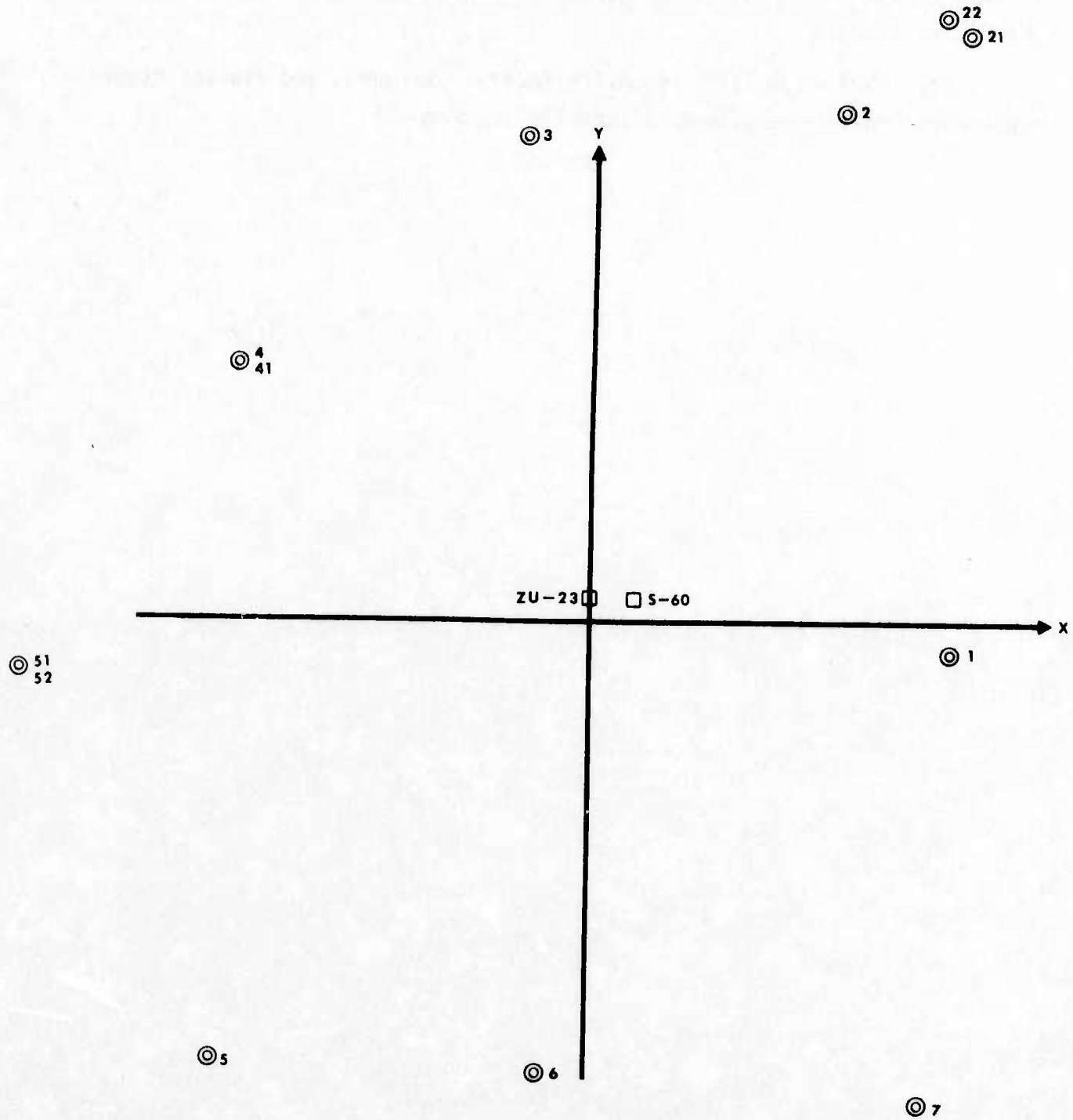

Figure 2-1. Surveyed Targets and Gun Positions

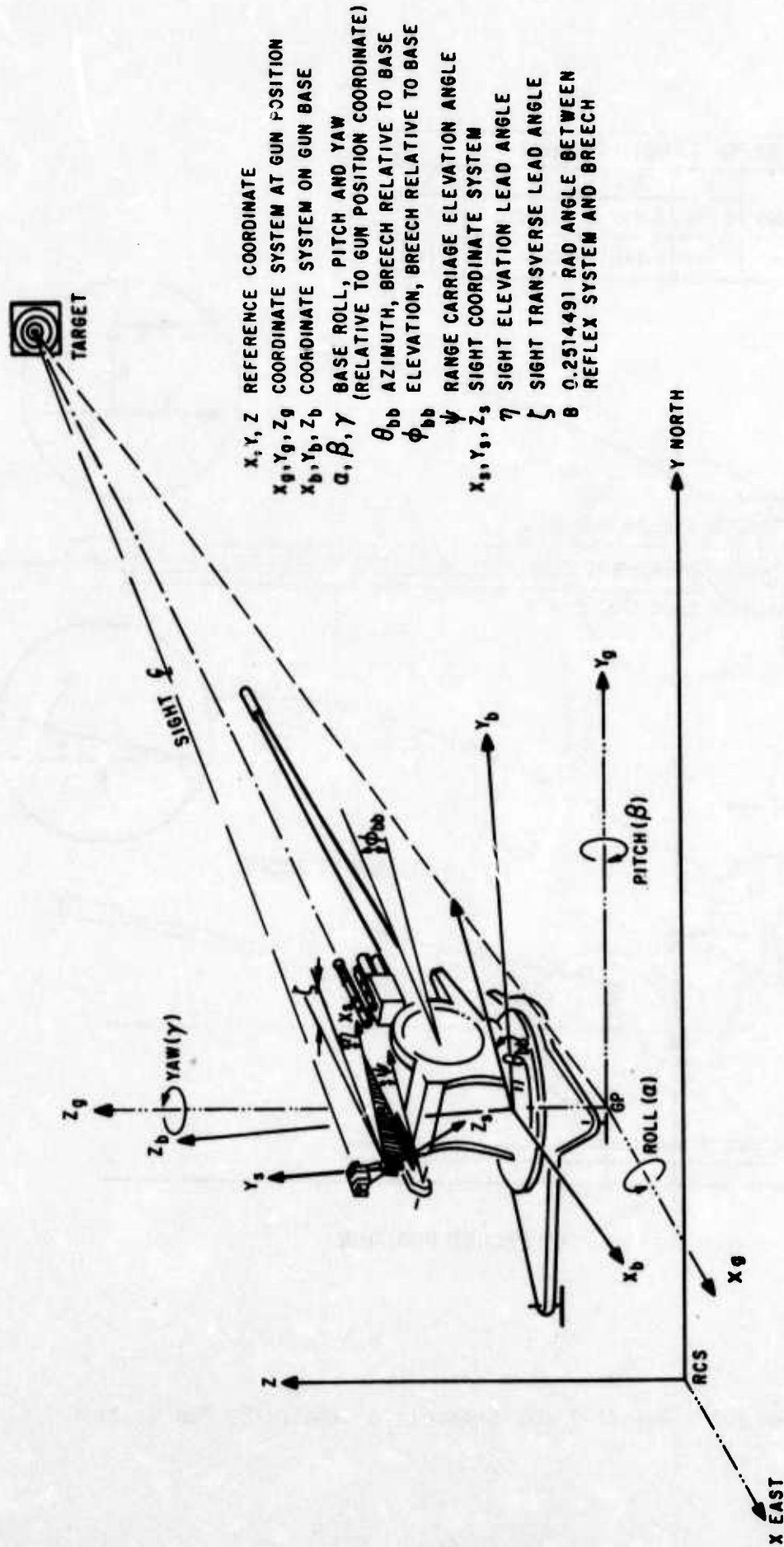

Figure 2-2. Angles Measured on the Gun System ZU-23

LINKAGE LENGTH (meters)					
	a	b	c	d	e
ALIGNMENT SCOPE	0.725	0.398	0.0	0.0	0.358
TRACKING SIGHT	1.072	0.364	0.259	0.357	0.114

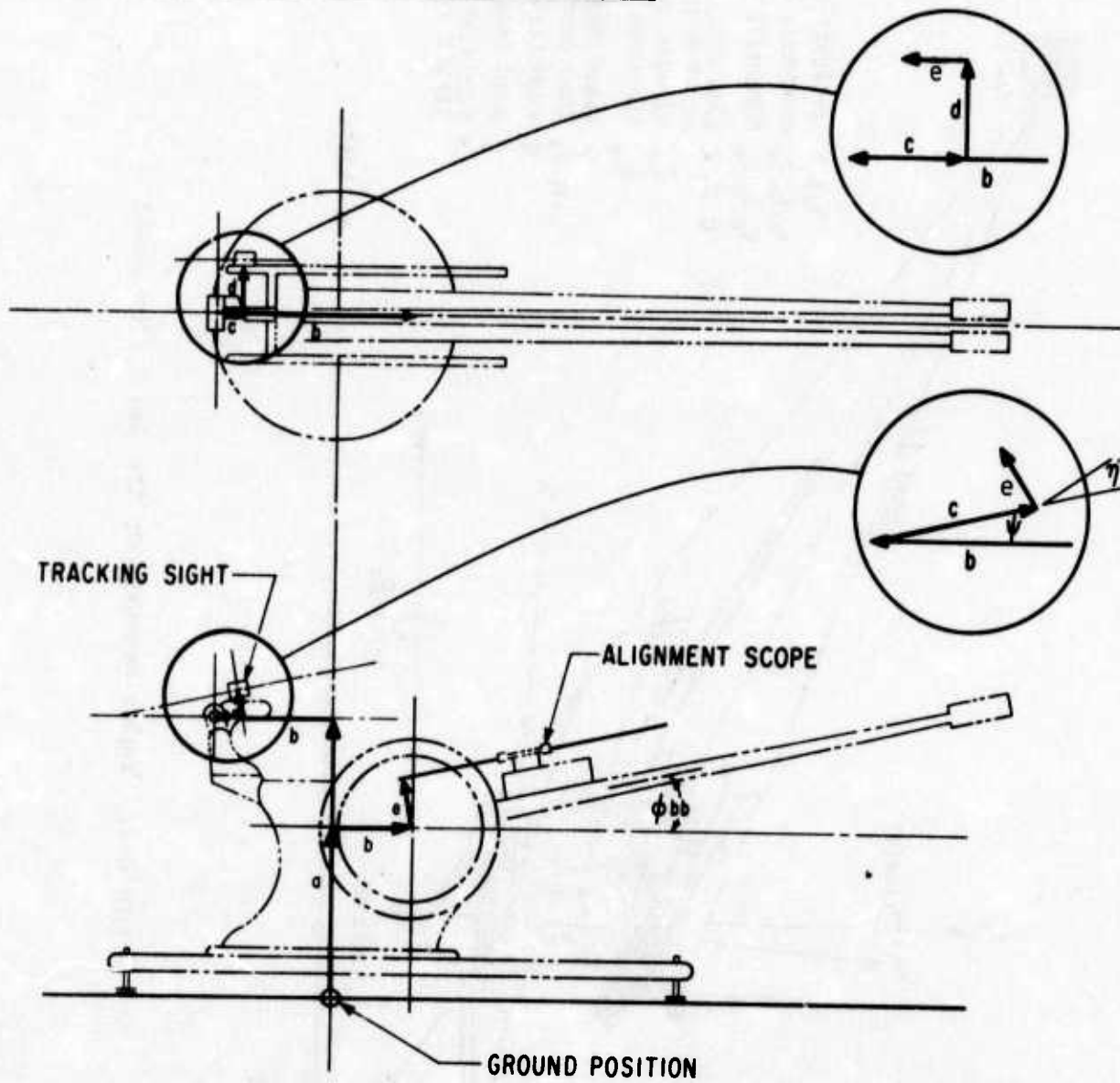

Figure 2-3. Physical Measurements on the ZU-23 Gun System

LINKAGE LENGTH (METERS)					
	a	b	c	d	e
ALIGNMENT SCOPE	1.14	0.0	0.0	0.0	0.375
TRACKING SIGHT	1.482	-0.777	0.159	0.435	0.058

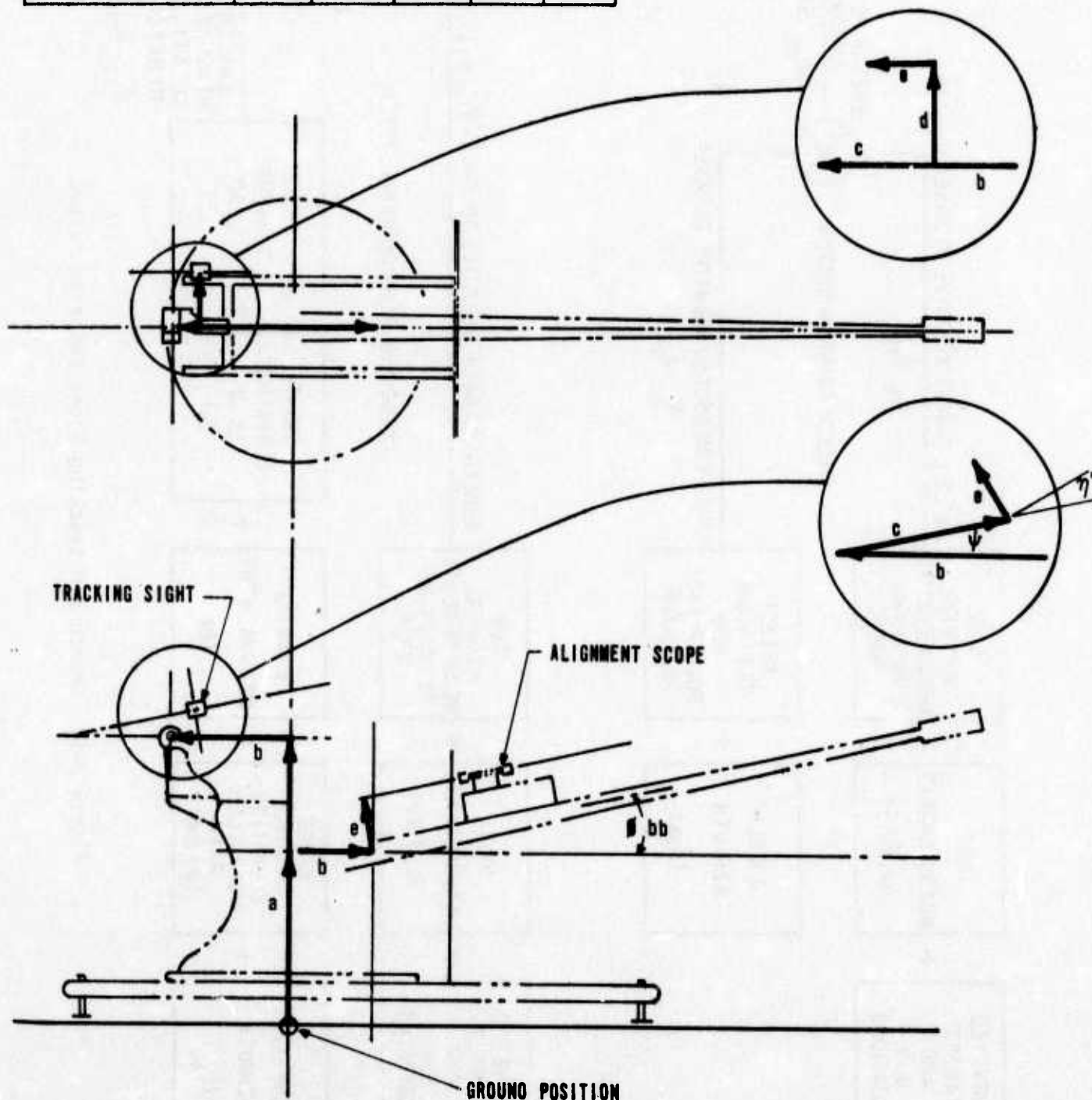

Figure 2-4. Physical Measurements on the S-60 Gun

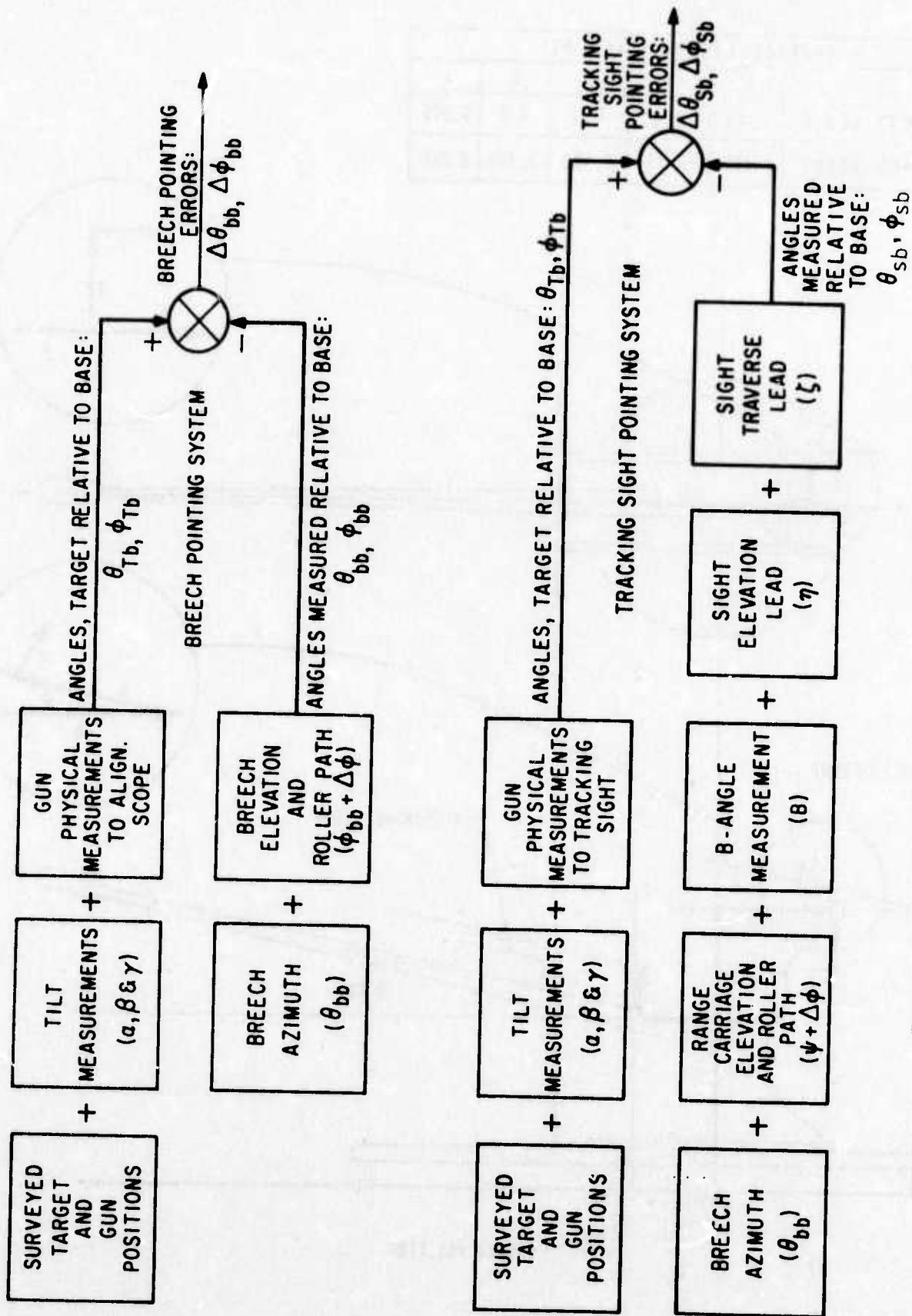

Figure 2-5. Breech and tracking Sight Pointing Errors

TIME 52236.100 FRAME 1 30.OCT

SCALED RAW DATA

TILT	INDICATORS	BREECH	FIRE CONTROL INPUT	SIGHT
ROLL .0007	WEAPON MODE 0	AZ 1.7204	SPEED .2	RCE .0334
PITCH .0010		EL .0051	COURSE ANGLE 3.14	TL .2506
YAW -.0013			CL/DV ANGLE .00	EL -.0300
AZ -.0013		MUZZLE	RANGE 50.	
EL .0006				
		LEFT M .0000	AZ .0000	AZ 1.7197
		LEFT L .0000	EL .0000	EL .0044
		RIGHT M .0001	AZ .0001	
		RIGHT L .0000	EL -.0000	

SURVEYED DATA IN GUN FRAME

TARGET 3	ZU-23	BREECH	TILT	DIFFERENCES - SURVEYED INST BREECH	BREECH AND SIGHT
X -295.203	X -5.604	X0 .0591	ROLL .0007	AZ .0002+	AZ .0006
Y 2064.355	Y 128.491	Y0 -.7917	PITCH .0010	EL -.0014+	EL -.0006
Z 11.466	Z 1.590	Z0 -1.0625	YAW -.0013		
AZ 1.7206+ 4407.					
EL .0037+ 4105.					

The following is a description of the values which appear on the output listing of the static scoring test program.

Time--in seconds as received from the raw data. Includes no bias.

Frame--number of the frame (record) on the raw data disc from which the data were computed. Only the first set of data in a record is used in the static program.

Scaled raw data--data computed from the instrumentation acquired data.

Tilt--raw unsmoothed roll, pitch, and yaw scaled to radians. Tilt in Az and El.

Weapon mode--0 = nonfiring; 4 = firing pedal depressed.

Breech--azimuth and elevation of the breech relative to the base. The roller path correction has been applied to the elevation.

Fire control input--Direct readings from the instrumentation scaled to engineering units.

Sight--elevation lead and traverse lead are direct readings from the instrumentation, scaled to engineering units. Range carriage elevation has been corrected for the roller path. Az and El are relative to the base.

Muzzle--x and y are the muzzle super angles in radians. Az and El are corrections to be added to breech azimuth and elevation.

Surveyed data in gun frame--data gathered by actual measurement rather than through the instrumentation.

Target--x, y, and z are the RCS* coordinates of the target; Az and El are relative to the breech using the surveyed tilts.

Breech--coordinates of the gun position relative to the alignment scope (i.e., coordinates needed for translation of alignment scope to gun position).

Tilt--zero for alignment; read from autocollimators for scoring test.

Differences--

Surveyed breech and instrumented breech--azimuth and elevation of the target as derived from surveyed data minus azimuth and elevation of the target as derived from instrumentation data, from the alignment scope optical element.

Surveyed breech and sight--azimuth and elevation of the target relative to the base from the sight optical element; data derived from the survey minus instrumentation data.

Values to the right of the arrow represent the value in counts.

*RCS--Reference Coordinate System.

Figure 2-6. Sample Computer Printout of the Static Engineering Unit Program

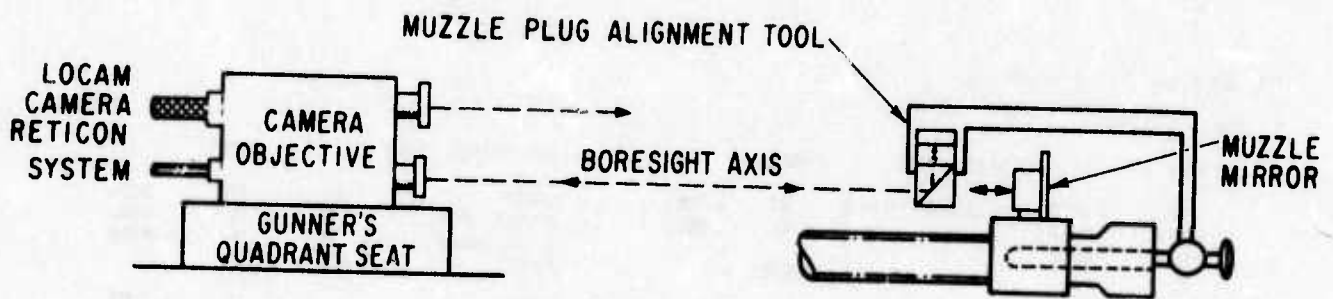
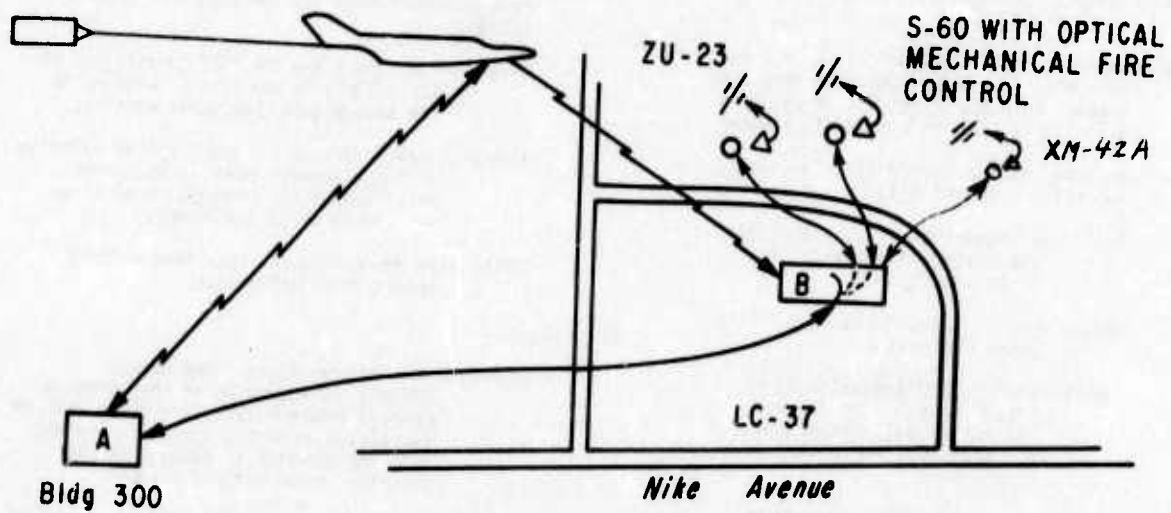

Figure 2-7. Alignment Concept



- A - TEST CONDUCTOR, AIRCRAFT CONTROLLER AND WSMR TEST SUPERVISOR
- B - SITE CONTROLLER AND EG&G SITE SUPERVISOR
- - GUN CONTROLLER
- △ - BATTERY COMMANDER

Figure 2-8. Test Site Communications

APPENDIX 3
DATA PROCESSING

The purpose of this appendix is to identify the sources of data, the general flow of the data, and the data reduction.

A. DATA SOURCES

SST data includes quantitative data necessary for calculations and analysis, and qualitative information not necessary for calculations, but essential for proper interpretation of the data.

1. Direct Digital Gun Data

The GIU sat near the gun and transmitted, via hard wire, gun data to the EG&G recording and processing van. The HP 2100A computer system served to collect the digital gun data on discs in virtually a real-time mode. Beyond manual switching to initiate the data collection process by computer, this aspect of the data collection system was fully automatic. Automatic data collection via the computer was terminated by manual intervention of the computer operator upon command of the site controller located in the EG&G recording and processing van. The gun instrumentation is one data source used in the system scoring test.

2. Gun Crew Tracking Data

LOCAM cameras mounted on the gun and boresighted to the barrel provided film data of the crew tracking capability. The film was digitized into a BCD (binary coded decimal) tape format, and the tape is the second source of data for the system scoring test.

3. Target Data

WSMR collected target TSPI data with both radar tracking of a luneberg lens on the target fuselage and cinetheodolite tracking of a flare near the aft end of the towed target for HITVAL I, and the retroreflector array on the F-4 aircraft for HITVAL II. TSPI for these tracked points is presented to the DCO (data control officer) on magnetic tapes within 5 and 10 working days, respectively, after each test trial. These data tapes are the third data source used in the system scoring test.

4. Test Operations Data

a. The test conductor manually completed a test operations log sheet and summary test reports including input data from the WSMR control officer and the aircraft controller who were located with him in Bldg 300.

b. The site controller manually completed his test operations log sheet including input data from the EG&G supervisor who was located with him in the EG&G recording and processing van.

c. Debriefing forms were filled out by the test conductor's assistant after each mission.

d. A consolidated summary of trials (section III, paragraph 2.c) was accumulated from these sources and the fourth data source is available.

B. DATA FLOW

1. Gun Data Flow

The gun data originated during the trial at the encoders and resolvers on the gun. The data were recorded in the EG&G recording and processing van on discs in essentially real time. Immediately after the mission the computer disc was removed and given an external label for identification purposes. As soon as practicable EG&G transferred the data from disc to tape. The tape was externally labeled and delivered to the DCO as the "raw gun data tape." The raw gun tape was processed through the dynamic engineering unit conversion program and a new digital gun tape was developed. This gun tape is delivered to AFWL for merging and processing.

2. Gun Film Data Flow

The gun film from the LOCAM cameras was developed as soon as possible after the mission was completed. The developed film was transmitted to EG&G for reading, processing, and digitizing. The digitized film tape was forwarded to AFWL for merging and processing.

3. Target TSPI Data Flow

a. TSPI data were transmitted in the form of computer tapes to the DCO within 5 and 10 working days for the radar and cinetheodolite tracking, respectively, after each test trial.

b. Data delivered by WSMR already had considerable data reduction prior to reaching its collection point at the DCO's office. Figures 3-1 and 3-2 describe the WSMR data in its reduced and properly formatted form according to trial-varying trajectory information and trial-constant header information, respectively.

c. The radar and cinetheodolite data were delivered to AFWL for merging and processing.

4. Test Operations Data Flow

a. The test conductor and his assistant recorded event data at Bldg 300 during each trial run. After mission debriefing, a test summary was written. Debriefing forms were consolidated for this test summary. A consolidation of these test summaries, test conductors logs, debriefing sheets, and site controllers logs was accomplished on a master summary of trials. The summary of trials was forwarded with each tape developed so that a common identification scheme is included with all data. The summary is not essential for calculation of data but is most essential in evaluation of trials. The summary of trials is included in this test report (section III, paragraph 2.c).

b. Figure 3-3 shows the data flow as discussed. This illustration is an overview of the complete data flow showing the different agencies involved along with the different data sources and processing.

C. DATA REDUCTION

1. EG&G

a. Gun Tape Data

Final gun tapes developed from the dynamic engineering unit program follow the format listed in WSEG Paper 951. The data have gun azimuth and elevation, tilt, muzzle deflection, and sight/computer inputs converted to engineering units (tables 3-1, 3-2, and 3-3).

b. Gun Film Data

Camera film from the LOCAM camera was digitized into an engineering unit tape containing time of the frame, digitized Δ azimuth in engineering units of the gun frame, and Δ elevation in engineering units of the gun frame.

Table 3-1
DATA ELEMENTS, ZU-23

Data Element	Data Rate	Range	Accuracy
Specified initial gun azimuth	once ^a	0 to 360°	20 mrad
Target mask condition	10/sec	masked & unmasked	--
Target detection time	once	--	1 sec
Crewman detecting target	once	--	
Time of possible open fire	once	--	1 sec
Time of fire of each round ^b	--	--	1 msec
Gun pointing angles relative to base:			
Azimuth	10/sec	0 to 360°	0.4 mrad
Elevation	10/sec	-10° to +90°	0.4 mrad
Tilt of gun base:			
Azimuth	10/sec ^c	-2 to +20 mrad	0.6 mrad
Elevation	10/sec ^c	-20 to +20 mrad	0.6 mrad
Angular tracking errors of the optical sight:			
Azimuth	20/sec	-100 to +100 mrad	1 mrad
Elevation	20/sec	-100 to +100 mrad	1 mrad
Inputs to the fire control system:			
Speed	10/sec	0 to 330 m/sec	1 m/sec
Course angle	10/sec	0 to 360°	4 mrad
Climb or dive angle ^d	10/sec	-90 to +90°	4 mrad
Range	10/sec	0 to 3,300 m	50 m

^aOnce per trial.

^bThere are also nonfiring trials. In these, the time that the firing pedal is depressed and the time it is released must be recorded to the nearest tenth of a second.

^cThis quantity is also required at the precise time of fire of each round.

^dClimb is defined as positive; dive, as negative.

Table 3-2
DATA ELEMENTS, S-60

Data Element	Data Rate	Range	Accuracy
BOTH S-60 CONFIGURATIONS			
Specified initial gun azimuth	once	0 to 360°	20 mrad
Target mask condition	10/sec	masked & unmasked	--
Target detection time	once	--	1 sec
Crewman detecting target	once	--	--
Time of possible open fire	once	--	1 sec
Time of fire of each round ^a	--	--	1 msec
Gun pointing angles relative to base:			
Azimuth	10/sec	0 to 360°	0.4 mrad
Elevation	10/sec	-4 to +87°	0.4 mrad
Tilt of gun base:			
Azimuth	10/sec ^b	-20 to +20 mrad	0.6 mrad
Elevation	10/sec ^b	-20 to +20 mrad	0.6 mrad
S-60 WITH OPTICAL-MECHANICAL FIRE CONTROL SYSTEM			
Angular tracking errors of the optical sight:			
Azimuth	20/sec	-100 to +100 mrad	1 mrad
Elevation	20/sec	-100 to +100 mrad	1 mrad
Inputs to the fire control system:			
Speed	10/sec	0 to 300 m/sec	1 m/sec
Course angle	10/sec	0 to 360°	4 mrad
Climb or dive angle	10/sec	-90 to +70°	4 mrad
Range	10/sec	0 to 5,500 m	50 m
S-60 WITH FIRE DIRECTOR			
Radar tracking data:			
Range	10/sec	0 to 20 km	10 m
Azimuth	10/sec	0 to 360°	0.5 mrad
Elevation	10/sec	-4 to 87°	0.5 mrad
Optical tracking data:			
Azimuth	20/sec	0 to 360°	0.5 mrad
Elevation	20/sec	-4 to +87°	0.5 mrad
Range input to director	10/sec	0 to 20 km	10 m
Range output of altitude unit of director	10/sec	0 to 20 km	10 m
Fire director data for target speed (3 components)	10/sec	-350 to +350 m/sec	1 m/sec
Fire director outputs (gun commands):			
Azimuth	10/sec	0 to 360°	0.4 mrad
Elevation	10/sec	-4 to +87°	0.4 mrad
Fire director settings ^c :			
Muzzle velocity correction	once	-12 to +8%	visual ^d
Wind speed (2 components)	once	0 to 30 m/sec	visual
Air density	once	-20 to +20%	visual
Air temperature	once	-40 to +50°C	visual
Parallax (? components)	once	-600 to +600 m	visual
Settling time	once	6 or 15 sec	--
Solution indication	10/sec	off or on	--

^aThere are also nonfiring trials. In these, the time that the firing pedal is depressed and the time it is released must be recorded to the nearest tenth of a second.

^bThis quantity is also required at the precise time of fire of each round.

^cValues set by the crew into the fire director.

^dController should read the setting on the fire director.

Table 3-3

DATA ELEMENTS, HITVAL II GUN SYSTEM

Data Element	Data Rate	Range of Measurement	Accuracy	Remarks
Specified initial gun azimuth	once	0 to 360°	15°	Controller log
Target detection time	once	--	0.1 sec	Controller switch
Target detection mode	once	commander, gunner, radar A scope, or radar PPI	--	Controller log
Range at detection	once	--	250 m	Range TSPI ^a
Time at radar lock-on	once	--	0.1 sec	Event closure
MTI unit operating mode	once	operate, 1, 2	--	Controller log
Wobulation control	once	on or off	--	Controller log
Transmitter frequency	once	F1 or F2	--	Controller log
Fire control settings: Muzzle velocity correction	once	-10 to +6%	1%	Controller log
First time computer has solution	once	--	0.1 sec	Event closure
Target mask condition	10/sec	masked or unmasked	--	Controller switch
Hydraulic	10/sec	fast or slow	--	Switch position
Turret control	10/sec	semiautomatic or automatic	--	Switch position
Gunner's handgrip mode	10/sec	velocity or position	--	Switch position
Azimuth	10/sec	velocity or position	--	Switch position
Elevation	10/sec	velocity or position	--	Switch position
Fire solution indication	10/sec	on or off	--	Event closure
Fire enable	10/sec	yes or no	--	Event closure
Time of fire of each round	--	--	1 msec	Pressure Gage
Fire switch depression, upper pair	10/sec	on or off	--	Event closure
Fire switch depression, lower pair	10/sec	on or off	--	Event closure
Fire selector	10/sec	commander or gunner	--	Event closure only when there is a solution
AGC/MGC voltage	100/sec	0 to -5v (0 to -10v worst case)	0.5%	O.C. to digital
Gun angles relative to chassis:				
Azimuth	100/sec	-2π to +2π rad	0.4 mrad	Digital encoder
Elevation (relative to turret)	100/sec	-0.1 to +0.5π rad	0.4 mrad	Digital encoder

Table 3-3 (cont'd)

Data Element	Data Rate	Range of Measurement	Accuracy	Remarks
Chassis orientation relative to gyro:				
Yaw	10/sec	0 to 2π rad	3.0 mrad	Resolver to digital
Pitch	10/sec	-0.1 to +0.1 rad	3.0 mrad	Resolver to digital
Roll	10/sec	-0.1 to +0.1 rad	3.0 mrad	Resolver to digital
Tilt of chassis relative to RCS: ^b				
Yaw	100/sec	-20 to +20 mrad ^c	0.33 mrad	Autocollimator
Pitch	100/sec	-20 to +20 mrad ^c	0.33 mrad	Autocollimator
Roll	100/sec	-20 to +20 mrad ^c	0.33 mrad	Autocollimator
Radar data:				
Mode switching	10/sec	footnote d	--	Event closure
Tracking azimuth (relative to turret)	10/sec	0 to 2π rad	0.5 mrad	Digital encoder
Tracking elevation (relative to turret)	10/sec	-0.1 to +0.5 π rad	0.5 mrad	Digital encoder
Range	10/sec	-0.4 to +17.5 km	5 m	Encoder on shaft
Optical tracking data (left)				
Azimuth (relative to turret)	50/sec	0 to 2π rad	1 mrad	Digital encoder
Elevation (relative to turret)	50/sec	-0.1 to +0.5 π rad	1 mrad	Digital encoder
Optical tracking data (right)				
Elevation	10/sec	-0.1 to +0.5 π rad	2 mrad	Computed from gun elevation
Gunner's handgrip position				
Azimuth	50/sec	$\pm 0.25\pi$ rad	0.5%	400 Hz to digital
Elevation	50/sec	$\pm 0.25\pi$ rad	0.5%	400 Hz to digital
Fire control computer data:				
X	10/sec	-10 to +10 km	10 m	Measured output of computer X, Y, and H units
Y	10/sec	-10 to +10 km	10 m	
H	10/sec	-0.1 to +10 km	10 m	
Coasting	10/sec	yes or no	--	Event closure
Time of flight	10/sec	0 to 6 sec	0.005 sec	400 Hz to digital
Gun commands relative to gyro:				
Azimuth	10/sec	0 to 2π rad	0.4 mrad	Output of fire control computer
Elevation	10/sec	-0.1 to +0.5 π rad	0.4 mrad	

^aTSPi is time space position information (i.e., time history of position provided by range tracking instrumentation).

^bRCS is the earth-fixed reference coordinate system.

^cThis range is likely to increase.

^dCircular search (yes/no), circular search speed (fast/slow), sector search (yes/no), range autotrack (yes/no), angle mode (I, autotrack with range/II, manual), antenna scan (conical/linearly vertical), MTI (on/off), antenna pedestal controlled by commander's reflex sight (yes/no), and angle data range gating (normal/narrow).

2. Air Force Weapons Laboratory Data

a. Tabular Output

(1) AFWL prepared tabular output consisting of the following data for each trial.

- (a) Time (in seconds from Greenwich Mean Time).
- (b) Azimuth of the breech computed from either radar or cinetheodolite data, with the data from the gun, film digitized tape, and tilt included.
- (c) Elevation of the breech derived as in (b) above.
- (d) Gun instrumentation azimuth (from the gun tape).
- (e) Gun instrumentation elevation (from the gun tape).
- (f) Camera azimuth in milliradians (the interpolated values from the gun film tape used to calculate (b) above).
- (g) Camera elevation in milliradians (derived as in (f) above).
- (h) Azimuth tilt in milliradians (the azimuth tilt value was algebraically added to (b) above to translate (b) to the breech plane).
- (i) Elevation tilt in milliradians (the elevation tilt value was algebraically added to (c) above to translate (c) to the breech plane).
- (j) Azimuth differences in milliradians (differences in (b) and (d) above).
- (k) Elevation differences in milliradians (differences in (c) and (e) above).
- (l) Radial differences in milliradians (an approximation at small angles of the delta angle between target and gun pointing direction). This was by the formula:

$$\Delta r = \sqrt{(\Delta \theta \cos \phi)^2 + (\Delta \phi)^2}$$

(m) Interpolation time interval (rounded to the nearest tenth of a second, the time between the closest camera frame and the data at the time in question).

(n) The fire time (this printout indicated if the fire pedal was depressed).

(2) At the end of the tabular output for each trial, the mean, standard deviation, skew, the percent of the data between ± 0.8 mrad, and the maximum and minimum values of the data were printed for each of the azimuth and elevation differences, and for the radial values. These tabular data were broken out in the following areas:

- (a) Nonfiring, number of accepted points.
- (b) Nonfiring, number of total points.
- (c) Total number of accepted points.
- (d) Total number of total points.

Accepted points are those in which the interpolation intervals are 1 or 0 for HITVAL I and 0 between 0 for HITVAL II. It is recognized that this difference in acceptance criteria may bias HITVAL I data, but the difference was felt to be insignificant and is therefore not accounted for. Firing points are designated as points with the fire pedal depressed.

(3) Plotted Output

(a) An error histogram of each pass for azimuth and elevation differences and for the radial values was plotted in tenths of milliradian differences (accepted points only).

(b) An autocorrelation plot was made of each pass when sufficient points with no time breaks were available.

(c) Plots of azimuth and elevation differences and radial values versus time were made. If the interval was 2 or greater for HITVAL I and 1 or greater for HITVAL II, the plot was driven to zero.

(4) Tape Output

AFWL provided two tapes of the tabular data listed above to the JTF staff. There is a tape using radar data and a tape using cinetheodolite data for each of the two guns. These tapes are CDC compatible 556 BPI, and a format consistent with the data. Tapes will be shipped to WSEG/IDA upon completion of the test program.

3. White Sands Missile Range Data

White Sands Missile Range provided smoothed radar/cinetheodolite tapes and applicable data reduction as specified in the following.

a. Tabular output of each pass listing time, radar azimuth, elevation, and range; cinetheodolite azimuth, elevation, and range; azimuth differences $\Delta\theta$, elevation differences $\Delta\phi$, range differences Δr , and radial (azimuth and elevation combined) differences Δd (table 3-4). Radial difference is defined by

$$\Delta d = \sqrt{(\Delta\theta \cos \phi)^2 + (\Delta\phi)^2}$$

b. Mean, median, minimum and maximum values, standard deviation, and skew for each of the four differences for each pass (table 3-4).

c. A plot of each of the four differences for each pass in tenths of milliradians or tenths of meters.

d. A spectral density plot of the four differences for each pass.

e. A plot of differences each of the four versus time for each pass.

f. A digital magnetic tape (556 BPI, CDC compatible of (1) and (2) above will be provided).

Table 3-4

TABULAR OUTPUT

	<u>VARIABLE</u>	<u>FORMAT</u>	<u>UNITS</u>	<u>REMARKS</u>
	TIME	F9.3	SEC	Every .1 seconds
radar	elevation	F6.4	radians	
	azimuth	F6.4	radians	
	range	F6.1	meters	
cine	elevation	F6.4	radians	
	azimuth	F6.4	radians	
	range	F6.1	meters	
	elevation error	F7.4	radians	(cine)-(radar)
	azimuth error	F7.4	radians	(cine)-(radar)
	range error	F6.1	meters	(cine)-(radar)
	radial error	F7.4	radians	(cine)-(radar)

$$\Delta d = \sqrt{(\Delta\theta \cos \phi)^2 + (\Delta\phi)^2}$$

END OF TABULAR DATA

	MEAN	F6.4	radians
AZ	Standard deviation	F6.4	radains
	Skew	F6.2	
	MEAN	F6.4	radians
EL	Standard deviation	F6.4	radians
	Skew	F6.2	
	MEAN	F6.1	M
Range	Standard deviation	F6.1	M
	Skew	F6.2	
	MEAN	F6.4	radians
Radial	Standard deviation	F6.4	radians
	Skew	F6.2	

<u>Sequence</u>	<u>Parameter^a</u>	<u>Expressed in</u>	<u>Measured (or defined)</u>	<u>Format specifications on magnetic tape</u>
1	Time	seconds	from midnight, GMT	3PF10.0 ^{b,c}
2	X	meters	positive east of tangent point	2PF10.0
3	Y	meters	positive north of tangent point	2PF10.0
4	Z	meters	positive above tangent plane	2PF10.0
5	\dot{X}	meters/second	first time derivative of X	2PF10.0
6	\dot{Y}	meters/second	first time derivative of Y	2PF10.0
7	\dot{Z}	meters/second	first time derivative of Z	2PF10.0
8	\ddot{X}	meters/second ²	second time derivative of X	2PF10.0
9	\ddot{Y}	meters/second ²	second time derivative of Y	2PF10.0
10	\ddot{Z}	meters/second ²	second time derivative of Z	2PF10.0
11	Speed	meters/second	$+\sqrt{\dot{X}^2 + \dot{Y}^2 + \dot{Z}^2}$	2PF10.0
12	Heading ^d	radians	$\tan^{-1}(\dot{Y}/\dot{X})$	5PF10.0
13	Climb/dive	radians	$\tan^{-1}(\dot{Z}/\sqrt{\dot{X}^2 + \dot{Y}^2})$	5PF10.0
14	X quality	meters	standard deviation	2PF10.0
15	Y quality	meters	of	2PF10.0
16	Z quality	meters	smoothing residuals ^e	2PF10.0
17	Tracking mode			F10.0
18	Spare			A10
Total number of characters			180	

Notes:

^aSequence numbers indicate the order in which the parameters will appear within a TDR; sequence No. 1 being the earliest written. The component order indicated was chosen to preserve a right-hand coordinate system ordered in the sequence X,Y,Z.

^bMost significant place written earliest.

^cIn accordance with the FORTRAN definition of P-specification, and the units specified for the parameter. For example, the "time" quantity to be written on tape in F10.0 format is a number which is 1000 (10^3) times the number of seconds since midnight, GMT.

^dExpressed within the range $0 - 2\pi$ radians, with due regard for the signs of \dot{X} and \dot{Y} .

^eResiduals are the differences between raw (measured) data and corresponding times on a least-square parabola fitted to N points, where N is selected as experience has shown is appropriate for aircraft tracking.

Figure 3-1. WSMR Tracking Data Format

<u>Sequence</u>	<u>Item</u>	<u>Defined or expressed in</u>	<u>Format spec.</u>
1	Identification of trial	(not yet defined)	A10
2	Date	days from Jan. 1	I3
3	Aircraft identification	last 4 digits of tail no.	I4
4	Tracker identification	(coding to be defined)	I1
5	Number of points used to smooth	moving-arc smoothing	I2
6	Transponder reply freq*	megacycles	F10.0
7	Simulated weapon release time	seconds from midnight, GMT	3PF10.0
8	Spare (reserved for alpha-numeric data, or comments)		4A10
9	Surface atmospheric pressure	millibars	I4
10	Surface air temperature	degrees F	I3
11	Surface relative humidity	percent	I3
12	Surface air density	gm/m ³	I4
13	Direction of wind vector	degrees from north	I3
14	Wind speed	knots	I3
15	Ceiling	meters	I5
16	Visibility	km	I3
17	Time of met. data	hours from midnight, GMT	I2
18	Cloud cover	percent sky covered	I10
19	Spare		
Total number of characters			180

*Transponder frequency will be coded as blank for the laser tracking system.

Figure 3-2. WSMR Header Data Format

SST DATA PROCESSING FLOW

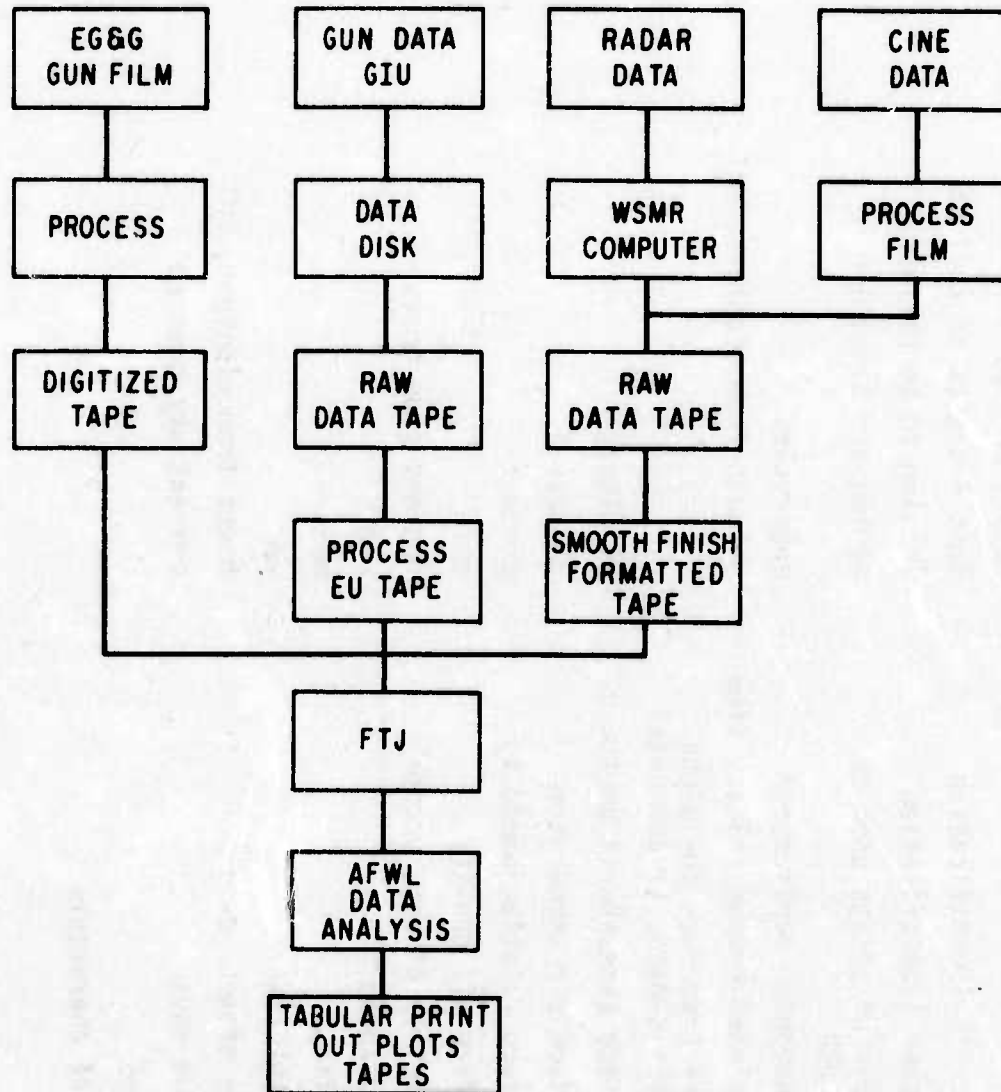

EU = ENGINEERING UNITS
 GIU = GUN INSTRUMENTATION UNIT

Figure 3-3. Data Flow Chart

APPENDIX 4

MATHEMATICAL REVIEWS, CALCULATIONS, AND ANALYSIS

This appendix is a compilation of the mathematical derivations, reviews, calculations, and analysis referenced in this report. This appendix is provided so that the main body of the report is reduced to essentials, and analysts who review the report can refer to the detail not mentioned in the main portion of the report.

A. ANALYSIS OF VARIANCES (ZU-23)

1. General

a. The breech azimuth and breech elevation measurement error data given in table II-2 were organized in a two-way table for the purpose of analysis and interpretation. The data were treated as a two-way classification, components of variance model with main effects being targets (rows) and roll-pitch conditions (columns). A test for independence was done to determine if it would be advisable to undertake the analysis of variance for breech elevation and breech azimuth measurement errors separately. Their correlation coefficient was found to be -0.2287 , which is not significant at the 0.10 level of significance. Thus, it was concluded that the two measurement errors are statistically independent and, therefore, each was studied separately. The calculations which led to this conclusion are summarized in this appendix, paragraph A.2.

b. The analysis of variance table for the breech azimuth measurement error data is given in paragraph A.3 of this appendix. The main effects of the target and roll-pitch are both statistically significant, but they do not have a significant interaction effect. Thus, it was concluded that their effects could be studied separately. Examination of the mean errors for targets indicates that the largest measurement errors occur for targets number 3, 4, and 7, the bias being positive for targets number 3 and 7 and negative for target number 4. The mean azimuth measurement error is plotted as a function of the azimuth from gun to target (figure 4-1). This plot indicates there is no systematic bias relative to this factor, and thus the component of variance attributable to targets should be included in the measurement of inaccuracy of the system.

c. The mean breech azimuth measurement error was greatest in the condition of near zero roll-pitch.

d. Examination of the arithmetic mean of the absolute values of measurement errors for the roll-pitch conditions included in the static test suggests there is no systematic error which can be corrected for by calibration and thus the component of variance attributable to roll-pitch condition should be included in any measure of inaccuracy of the system.

Breech Azimuth

<u>Source of variation</u>	<u>Estimated component of variance</u>
Targets	0.03537
Roll-pitch	0.005453
Interaction	0.000000
Experimental error	0.05056

e. The method of Thompson and Moore* was used to calculate the above estimates because the analysis of variance yielded a negative estimate of the interaction component of variance.

f. The total standard deviation of the breech azimuth measurement errors for the static test, the square root of the sum of the components of variance, is estimated to be 0.3023 mrad. Under the assumption of normality, this would estimate that, in a static test situation, on the average 99 percent of the measurements errors would be less than 0.8 mrad.

g. The analysis of variance for the breech elevation measurement errors is contained in paragraph A.3 and indicates neither the main effect nor the interaction components of variance are statistically significant. This seems to stem from the fact that the experimental error component of variance is quite large relative to the other components of variance. This infers there is no systematic bias in this error which can be corrected by calibration, and suggests that, as for the breech azimuth measurement errors, the total standard deviation of breech elevation measurement errors (the square root of the sum of the components of variance) should be used as a measure of inaccuracy. As

*Thompson, W. A., Moore, J. R., "Non-Negative Estimates of Variance Components," Technometrics, 5, pp. 441-450, 1961.

before, the procedure of Thompson and Moore was used to calculate the estimates of variance components which are given below.

Breech Elevation

<u>Source of variations</u>	<u>Estimated component of variance</u>
Targets	0.03850
Roll-pitch	0.00000
Interaction	0.02675
Experimental error	0.3088

h. The total standard deviation of the breech elevation measurement errors for the static test is estimated to be 0.6116 mrad. Under the assumption of normality, this would indicate that on the average 81 percent of the measurement errors are less than 0.8 mrad. Inspection of the data in table II-2 reveals that $30/36 = 83$ percent of the measurement errors are less than 0.8 mrad. This tends to substantiate the assumptions underlying the analysis done here.

i. In the static test environment where measurements were made under carefully controlled conditions, the breech elevation and breech azimuth measurements are at best marginal, relative to an 0.8-mrad accuracy requirement.

j. The experimental design used for this test was such that the effect of pitch and roll on measurement errors could not be studied separately.

2. Test for independence

a. The random variables X (breech azimuth measurement error) and Y (breech elevation measurement error) were assumed to have the bivariate normal distribution with parameters μ_x , μ_y , σ_x^2 , σ_y^2 , and ρ for the purpose of this analysis. The usual estimates for the parameters of this distribution are \bar{X} , \bar{Y} , S_x^2 , S_y^2 , and r , and the statistic $t = r \sqrt{(N-2)/(1-r^2)}$, was used to test the null hypothesis $H_0: \rho = 0$ against the alternative $H_1: \rho \neq 0$. The statistic t has student's t distribution with $N-2$ degrees of freedom, when $\rho = 0$. The null hypothesis was accepted at the 0.1 level of significance and, thus, X and Y were considered to be statistically independent for the purpose of further analysis.

b. The calculations are summarized below:

$$\bar{X} = \frac{1}{36} \sum_{i=1}^{36} X_i = 0.01639$$

$$\bar{Y} = \frac{1}{36} \sum_{i=1}^{36} Y_i = 0.05000$$

$$S_X^2 = \frac{1}{35} \sum_{i=1}^{36} (X_i - \bar{X})^2 = 0.3640$$

$$S_Y^2 = \frac{1}{35} \sum_{i=1}^{36} (Y_i - \bar{Y})^2 = 0.08462$$

$$r = \frac{\sum_{i=1}^{36} (X_i - \bar{X})(Y_i - \bar{Y})}{\sqrt{\left[\sum_{i=1}^{36} (X_i - \bar{X})^2 \right] \left[\sum_{i=1}^{36} (Y_i - \bar{Y})^2 \right]}} = -0.2287$$

$$\text{Statistic } t = r\sqrt{34/1-r^2} = -1.37$$

$$P_r(-1.37 \leq t \leq 1.37) = 0.8204$$

$$P_r(t < -1.37 \text{ or } t > 1.37) = 0.1796$$

3. Analysis of Variance Calculations

a. The breach azimuth measurement error data are given in table 4-1 and the analysis of variance for this data is presented in table 4-2. The F test indicates that the component of variance attributable to targets is significant at the 0.05 level of significance and the component of variance attributable to roll-pitch condition is significant at the 0.15 level of significance. The interaction component of variance is not statistically significant and is estimated to be negligible.

Table 4-1

BREECH AZIMUTH

Target	Average value of induced roll and pitch						Σ	Mean
	(1.2, 0.9)		(12.86, 11.05)		(-7.95, -8.46)			
1	0.05	0.01	0.22	-0.56	-0.09	0.01	-0.3600	-0.0600
2	0.20	-0.09	-0.03	-0.41	0.12	-0.10	-0.3100	-0.0517
3	0.71	0.43	0.23	0.56	0.25	0.03	2.2100	0.3683
4	-0.03	-0.31	-0.27	-0.31	-0.10	-0.31	-1.3300	-0.2217
5	0.40	0.11	-0.03	-0.02	-0.27	0.23	0.4200	0.0700
7	0.57	-0.09	0.31	0.30	-0.21	0.29	1.1700	0.1950
Σ	1.9600		-0.0100		-0.1500		1.8000	
Mean	0.1633		-0.0008		-0.0125		0.0500	

Table 4-2

ANALYSIS OF VARIANCE

<u>Source of variation</u>	<u>d.f.</u>	<u>S.S.</u>	<u>M.S.</u>	<u>F*</u>	<u>F**</u>
Rows (targets)	5	1.3140	0.2628	9.45	5.20
Columns (roll-pitch combination)	2	0.2340	0.1160	4.17	2.29
RXC interaction	10	0.2775	0.0278	0.44	
Subtotal	17	1.8235			
Error (within cell)	18	1.1383	0.0632		
Total	35	2.9618			

*Components of variance model.

**Pooling error and interaction.

$$P_r \{F(2,28) \geq 2.29\} = 0.14$$

b. The breech elevation measurement error data are given in table 4-3 and the corresponding analysis of variance is presented in table 4-4. None of the components of variance were found to be statistically significant.

Table 4-3

BREECH ELEVATION

Target	Average value of induced roll and pitch						Σ	Mean
	(1.2, 0.9)		(12.86, 11.05)		(-7.95, -8.46)			
1	0.50	0.67	1.07	0.81	0.15	0.48	3.6800	0.6133
2	0.58	0.51	-0.91	0.15	-0.80	0.46	-0.0100	-0.0017
3	0.14	-0.02	-1.36	-0.19	-0.62	0.74	-1.3100	-0.2183
4	0.19	0.69	-1.15	0.11	-0.66	0.54	-0.2800	-0.0467
5	-0.41	0.08	-0.26	-0.17	0.59	0.19	0.0200	0.0033
7	-0.45	-0.37	0.73	-0.34	-0.37	-0.71	-1.5100	-0.2517
Σ	2.1100		-1.5100		-0.0100		0.5900	
Mean	0.1758		-0.1258		-0.0008		0.0164	

Table 4-4

ANALYSIS OF VARIANCE

<u>Source of variation</u>	<u>d.f.</u>	<u>S.S.</u>	<u>M.S.</u>	<u>F</u>
Rows (targets)	5	2.9266	0.5853	1.58 not sig.
Columns (roll-pitch combination)	2	0.5513	0.2757	0.74 not sig.
RXC interaction	10	3.7006	0.3701	
Subtotal	17	7.1785		
Error (within cell)	18	5.5591	0.3088	
Total	35	12.7376		

B. REVIEW OF TRANSFORMATIONS

1. Azimuth and elevation angles for the surveyed targets were determined as precisely as possible in the RCS. Encoders and resolvers were used to measure these angles at the alignment scope and at the tracking sight for various tilts of the gun. The surveyed angles were transformed to the tilted frame centered on the alignment scope. The angles measured at the sight were also transformed to the alignment scope. The transformed surveyed angles were then compared with both the breech measurements and the tracking sight measurements. This work was done by the contractor, EG&G. The transformation from the tilted to the untilted frame in the determination of the direction translation from the gun position to the alignment scope were reviewed by the Army Materiel Systems Analysis Activity (AMSAA) members of the HITVAL test team (figure 4-2).

2. The coordinates of the target in the tilted reference frame (x,y,z) are expressed in terms of polar coordinates as follows:

$$\begin{aligned}x &= r \cos \phi_b \cos \theta_b \\y &= r \cos \phi_b \sin \theta_b \\z &= r \sin \phi_b\end{aligned}\tag{1}$$

Hence,

$$\tan \theta_b = y/x$$

and therefore,

$$\theta_b = \tan^{-1}(y/x)$$

and

$$\begin{aligned}x^2 + y^2 &= r^2(\cos^2 \phi_b \cos^2 \theta_b) + r^2(\cos^2 \phi_b \sin^2 \theta_b) \\&= r^2 \cos^2 \phi_b (\cos^2 \theta_b + \sin^2 \theta_b) = r^2 \cos^2 \phi_b\end{aligned}$$

Hence $\sqrt{x^2 + y^2} = r \cos \phi_b$ and since $z = r \sin \phi_b$,

$$\frac{z}{\sqrt{x^2 + y^2}} = \tan \phi_b$$

which implies

$$\phi_b = \tan^{-1} \left(\frac{z}{\sqrt{x^2 + y^2}} \right)$$

3. The coordinates $(\bar{x}, \bar{y}, \bar{z})$ in the untilted frame can be determined from the coordinates in the tilted frame when yaw (γ), pitch (β), and roll (α) angles are known. It is given by the following formulas:

$$\begin{aligned} \bar{x} &= (\cos \beta \cos \gamma) x - (\sin \gamma \cos \alpha) y + (\sin \beta \cos \alpha) z \\ \bar{y} &= (\sin \gamma \cos \beta) x + (\cos \alpha \cos \gamma) y - (\sin \alpha \cos \beta) z \\ \bar{z} &= (-\sin \beta \cos \gamma) x + (\sin \alpha \cos \gamma) y + (\cos \beta \cos \alpha) z \end{aligned} \quad (2)$$

Substituting for x, y, z in b. above, the expression in a. gives:

$$\begin{aligned} \bar{x}/r &= \cos \beta \cos \gamma \cos \phi_b \cos \theta_b - \sin \gamma \cos \alpha \cos \phi_b \sin \theta_b \\ &\quad + \sin \beta \cos \alpha \sin \phi_b \\ \bar{y}/r &= \sin \gamma \cos \beta \cos \phi_b \cos \theta_b + \cos \alpha \cos \gamma \cos \phi_b \sin \theta_b \\ &\quad - \sin \alpha \cos \beta \sin \phi_b \\ \bar{z}/r &= -\sin \beta \cos \gamma \cos \phi_b \cos \theta_b + \sin \alpha \cos \gamma \cos \phi_b \sin \theta_b \\ &\quad + \cos \beta \cos \alpha \sin \phi_b \end{aligned} \quad (3)$$

also

$$\begin{aligned} \bar{x} &= r \cos \phi_g \cos \theta_g \\ \bar{y} &= r \cos \phi_g \sin \theta_g \\ \bar{z} &= r \sin \phi_g \end{aligned}$$

and hence

$$\phi_g = \sin^{-1}(\bar{z}/r)$$

and

$$\theta_g = \tan^{-1}(\bar{y}/\bar{x})$$

4. Substituting from equation (2) in the above two equations expresses ϕ_g and θ_g as a function of β , γ , α , ϕ_b , and θ_b . By the same method, the angles ϕ_b and θ_b can be determined as a function of β , γ , α , ϕ_g , and θ_g .

C. RESOLUTION OF ENCODERS, RESOLVERS, AND AUTOCOLLIMATORS (ZU-23)

1. Table 4-5 shows the resolution of the instrumentation involved in determining the pointing position of the gun barrel. The purpose of this section is to analyze the effect of errors (due to lack of precision in instrumentation) in roll, pitch, yaw, breech azimuth, and breech elevation on the gun pointing position transformed to the untilted reference frame at the alignment scope. Other measurements shown in the table cannot be resolved to the degree of the five measurements included in this analysis and it is believed that they most probably would tend to increase the overall error.

Table 4-5
RESOLUTION OF ANGLE MEASUREMENT TRANSDUCERS

<u>Measurement</u>	<u>Instrument</u>	<u>Gear ratio</u>	<u>Resolution (mrad or meters)</u>
Base roll, α	Autocollimator	---	0.333
Base pitch, β	Autocollimator	---	0.333
Base yaw, γ	Autocollimator	---	0.333
Breech az, θ_b	14-bit encoder	1:1	0.383
Breech el, ϕ_b	14-bit resolver	7.988:1	0.384
Range carriage, ψ	11-bit resolver	3.2:1	0.959
Sight el lead, η	11-bit resolver	4.0:1	0.767
Sight traverse lead, ζ	11-bit resolver	4.0:1	0.767
Target velocity, U	11-bit resolver	1:1	0.176
Target course, χ	11-bit resolver	1:1	3.067
Target climb/dive, δ	11-bit resolver	2:1	1.534
Target range, R	11-bit resolver	1:1	Nonlinear 6.36 m at 3300 m

2. The actual error in each of the five measurements is assumed to be uniformly distributed with zero mean and range from $-1/2$ times the resolution of measurement to $+1/2$ times the resolution of measurement. The following equations are used to determine the azimuth and elevation angles in the untilted

frame from the five angles, α , β , γ , θ_b , and ϕ_b :

$$\phi_g = \sin^{-1} \left(\sin \phi_b \cos \beta \cos \alpha + \cos \phi_b \sin \theta_b \sin \alpha \cos \gamma \right. \\ \left. - \cos \phi_b \cos \theta_b \sin \theta_b \cos \gamma \right)$$

$$\theta_g = \tan^{-1} \left(\frac{\cos \phi_b \cos \theta_b \sin \gamma \cos \beta + \cos \phi_b \sin \theta_b \cos \alpha \cos \gamma - \sin \theta_b \sin \alpha \cos \beta}{\cos \phi_b \cos \theta_b \cos \gamma \cos \beta + \sin \phi_b \sin \beta \cos \alpha - \cos \phi_b \sin \theta_b \cos \alpha \sin \gamma} \right)$$

3. A sketch of the derivation of these two transformations is shown in figure 4-2.

4. To represent the uniform distribution, the largest negative, largest positive, and zero errors were considered to be equally likely. Assuming the five measurements were independent, there were 3^5 or 243 equally likely outcomes to be considered for the angles ϕ_g and θ_g . These outcomes were then compared with the values for ϕ_g and θ_g computed when the assumed actual values for α , β , γ , θ_b are used. Table 4-6 shows the assumed angles which are approximately equal to those used for three of the tilts in the static test for target No. 1 (section II, table II-2). The angles are in radians.

Table 4-6
ASSUMED ACTUAL ANGLES

	<u>Small tilt</u>	<u>High positive tilt</u>	<u>High negative tilt</u>
α	0.001	0.01	-0.008
β	0.001	0.01	-0.008
γ	-0.001	-0.001	-0.001
ϕ_b	0.008	0.019	-0.003
θ_b	6.140	6.140	6.140

5. A computer program was written to calculate the 243 error outcomes for ϕ_g and θ_g . The program printed out ϕ_g and θ_g in radians. The errors were printed out in milliradians. The mean and standard deviation were computed in milliradians.

6. The results of this analysis are shown in table 4-7. Again, the angles are in radians. It is apparent that the error due to the effect of the resolution on this transformation was unbiased, and the standard deviation was smaller than what was observed in the static test (e.g., 0.22 milliradians for $\Delta\phi_g$ as compared with 0.60 milliradians for the static test). This was probably due to the errors in the other angular measurements, and perhaps some other differences were due to factors in the test conditions. The largest differences occurring were less than 0.4 milliradians in absolute value. This analysis indicates that the resolution in these five measurements was not a major contributor to total instrumentation error.

Table 4-7

RESOLUTION DISTRIBUTION SUMMARY

	θ_g	ϕ_g	$\overline{\Delta\theta}_g$	S_{θ_g}	$\overline{\Delta\phi}_g$	S_{ϕ_g}
Small tilt	6.13581	0.00687	0.00000	0.00021	0.00000	0.00022
High positive tilt	6.13565	0.00767	0.00000	0.00021	0.00000	0.00022
High negative tilt	6.13579	0.00606	0.00000	0.00021	0.00000	0.00022

D. DATA MEANS AND STANDARD DEVIATION PROCEDURES

1. The sample mean (\bar{X}) for the observations for each trial was computed by the following formula:

$$\bar{X} = \frac{\sum_{i=1}^N X_i}{N}$$

where X_i is the observation and N is the number of observations.

2. The sample standard deviation (S) is defined as the square root of the variance. Thus the sample standard deviation is given by

$$S = \sqrt{\frac{\sum_{i=1}^N x_i^2 - \frac{\left(\sum_{i=1}^N x_i\right)^2}{N}}{N-1}}$$

3. The number of acceptable data points was used in the calculation of the sample mean and standard deviation of the trial. The gunner's tracking error for the calculation of the instrumentation error was computed by interpolating less than 0.2 of a second on HITVAL I and 0.1 of a second for HITVAL II camera film data. This defined an acceptable data point. Therefore, these values represent the best estimate of the standard deviation of the instrumentation error for the trial.

E. CHI-SQUARED GOODNESS OF FIT TEST

1. Prior to using the chi-squared goodness of fit test, autocorrelation tests were accomplished on trials that have long continuous acceptable tracks (paragraph F). If the test indicated random data, the chi-square goodness of fit test was used to test the hypothesis that the data are normally distributed. This was done for both elevation and azimuth angle errors when applicable. The test statistic is

$$\chi^2 = \sum_{i=1}^K \frac{(f_{o_i} - f_{e_i})^2}{f_{e_i}}$$

f_{o_i} = observed frequency in the i th cell (i.e., number of observed values in the i th cell).

f_{e_i} = expected frequency in the i th cell.

$$\alpha = P(\chi^2 \geq \chi_{\alpha}^2, K-3) = 0.10$$

2. Degrees of freedom associated with χ^2 are $K-3$ where K is the number of cells. A small value of χ^2 is associated with good agreement between observed and expected values; a large value indicates discrepancy. The sample has been rejected as not being normally distributed if the test statistic χ^2 is such that

$$\chi^2 \geq P(\chi^2_{0.10, K-3})$$

A value of $\chi^2 < P(\chi^2_{0.10, K-3})$ indicates that the normal distribution has not been rejected.

F. AUTOCORRELATION PLOTS

1. The autocorrelation function for azimuth and elevation errors are plotted. These functions show if the variable at any time t is related to itself at time $t+k$ where k is called the number of lags. For this data, one lag is equal to 0.1 second. If the data were purely random (i.e., white noise), the theoretical autocorrelation function would be zero for all lags other than zero. The sample autocorrelation function for random data should exhibit small variation around zero. For sufficient sample size (250 samples or more is probably sufficient) the sample autocorrelation $r_{xx}(k)$ defined by

$$r_{xx}(k) = \frac{\sum_{t=1}^{N-k} (x(t) - \bar{x})(x(t+k) - \bar{x})}{\sum_{t=1}^N (x(t) - \bar{x})^2}$$

is approximately normally distributed with mean zero and variance $1/N$, when the data are random. Also if the data are random, the estimators $r_{xx}(j)$ and $r_{xx}(k)$ are independent for $j \neq k$, and j and $k \neq 0$. These facts enable one to use the interval $[-1.96/N, +1.96/N]$ as a 95 percent confidence interval for $r_{xx}(k)$, for $k \neq 0$, under the hypothesis that the data are random. By computing $r_{xx}(k)$ for the first 30 or 40 lags, approximately 95 percent of the $r_{xx}(k)$ would be expected to fall within the above mentioned interval.

2. Another autocorrelation estimator which is denoted by $r'_{xx}(k)$ is defined by

$$r'_{xx}(k) = \frac{\frac{1}{N-k} \sum_{t=1}^{N-k} (x(t) - \bar{x})(x(t+k) - \bar{x})}{\frac{1}{N} \sum_{t=1}^N (x(t) - \bar{x})^2}$$

and is also commonly used. Since $r'_{xx}(k) = r_{xx}(k) \cdot N/N-k$, it is very easy to determine either of these estimators from the other.

3. The behavior of the autocorrelation function gives an indication of the process. For example, moving average processes of low order are characterized by a nonzero autocorrelation for a few lags and zero autocorrelation for all other lags. Certain first order autoregressive processes are characterized by an acf (autocorrelation function) which declines exponentially, and certain second order autoregressive processes are characterized by an acf which behaves like an exponentially damped sine wave. Seasonality in a stationary process is indicated by spikes in the acf at lags of the length of the period.

4. The examples described above are illustrations of some of the various types of stationary stochastic processes. A process is stationary, in layman's terms, if the distribution of values does not change with time. There are many processes aside from white noise which are stationary and for which the acf is useful. A process which is not stationary is termed nonstationary. Nonstationary processes are characterized by autocorrelation functions which have high positive values for many lags and show only a slow decline in value. The acf is not very meaningful or useful for nonstationary processes; however, it is useful in detecting nonstationarity. Nonstationarity was detected for some of the data. By examining the average for different segments of the time series, it was noted that the mean of the distribution was changing with time. The data were definitely characterized as nonstationary, and therefore also as nonrandom.

5. The randomness test is important for statistical inference since it is commonly assumed that successive values are realizations of independently, identically distributed random variables. It is therefore important that the data pass a randomness test for goodness of fit tests and confidence interval statements to be meaningful.

G. RAW POSITION SIGMAS PROCEDURE

1. The raw, X, Y, and Z positions were computed by using a computer program with inputs from each cinetheodolite azimuth and elevation. An angular standard deviation (sigma A) and the component position standard deviation (sigmas X, Y, and Z) were computed for each unsmoothed position point. The angular standard deviation is a function of the residual angles associated with each camera and was computed using the equation

$$\sigma_A = \left[\left[\sum_{i=1}^N \left((DA_i (\cos E_i))^2 + DE_i^2 \right) \right] / (2N-3) \right]^{1/2}$$

where DA_i and DE_i are the angular residuals associated with the i th camera, and N is the number of cameras retained in the position solution. The position components standard deviations were computed as a function of σ_A and the co-factors of the principal diagonal in the least-squares determinant that was used in the position solution.

2. The line of sight from each station was defined from observed azimuth and elevation angles. After the observed azimuth and elevation angles were corrected for atmospheric refraction and systematic errors of the instrumentation, an N -station least squares solution was used to compute the expected position data. The computed position was determined as that point for which the sum of the squares of the angular difference between the expected position and observed position was a minimum. By using the component position standard deviations at each position (σ_x , σ_y , and σ_z), a root mean square (RMS) radial (r) sigma was determined for each raw data position. By using the 3-sigma values, 99.8 percent probability estimate can be obtained concerning the precision of each raw position. Since the radial sigma was a varying value, a plot of radial sigma versus time for each analyzed trial was made (annex C). The size of this probability estimate was contingent on the number of cinetheodolite stations used in the solution for the raw position. The computer program that developed this raw position used a weighting factor dependent on the number of stations tracking varying from 1.7 with two stations to 1.1 with maximum stations (9). Since the number of stations was critical and affected the radial sigma, the sigma plots included a plot containing the number of cinetheodolite stations at the same time. Table III-7, section III, was prepared to provide ranges of radial sigmas for each trial.

H. SMOOTHING RESIDUALS PROCEDURE

1. The raw positions determined in the raw cinetheodolite tapes was constrained to fit a smooth curve approximating the track of the tow target. This curve was developed by using a 21-point least squares fit. The residuals or differences from the raw position to the smooth curve position were summed for the 21 points and an average smoothing residual was determined. Since the curve fitting process was a continuing process (i.e., a new point was added as the 21st point was dropped), the average was time varying. The range provided average smoothing residuals in x , y , and z for each point in the track. The RMS values of these residuals were calculated and plotted in annex C.

2. The process of fitting raw positions to the smooth curve provided a better fit to the real world situation than was determined by just raw positions in the final output tape. Therefore, the smoothing residuals provide some guide as to the amount that raw sigmas on the average can be corrected, to provide error estimations for the cinetheodolite position uncertainties.

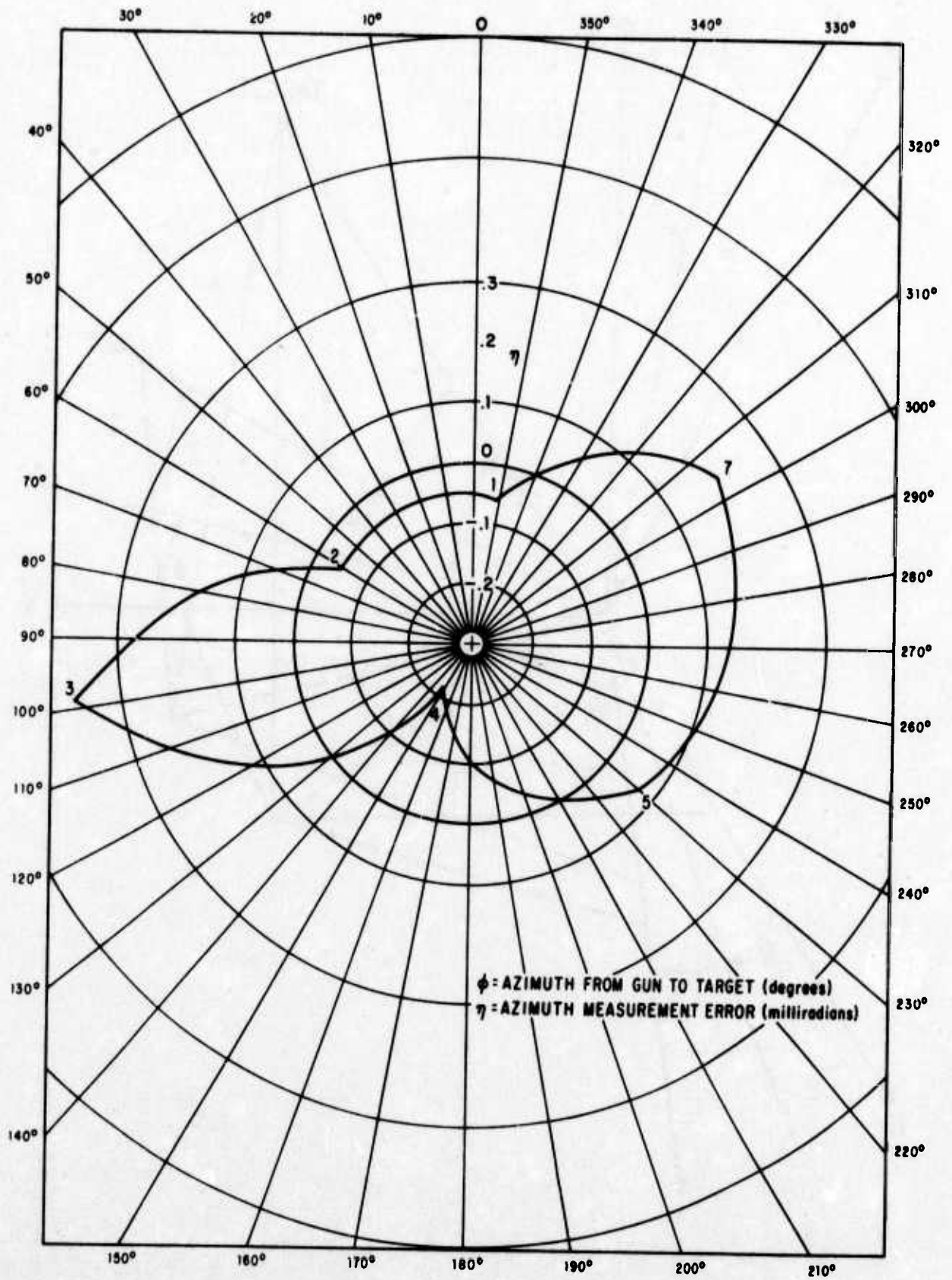

Figure 4-1. Azimuth Measurement Error versus Azimuth

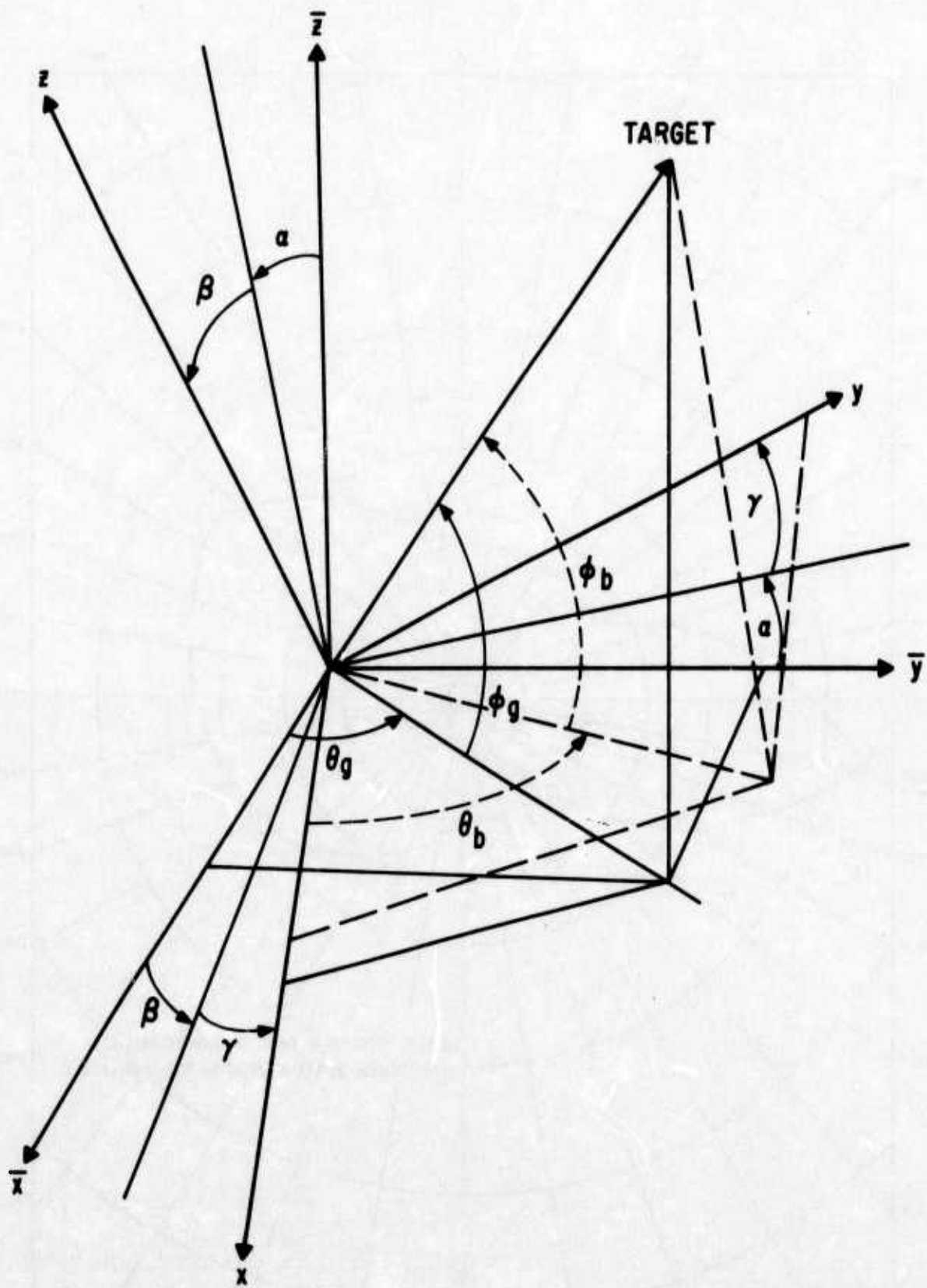

Figure 4-2. Transformation from Tilted to Untilted

DISTRIBUTION

<u>No. cys</u>		<u>No. cys</u>	
1	Hq USAF, Wash, DC 20330	1	Ord Sys Comd, Dept Navy, Wash, DC 20360
2	(SAMI)		
2	(SAV)	1	Comdg Off, NWEF (Code ADS), Kirtland AFB, NM 87117
2	(XOOF)		
1	Hq AFTAC (TAP), Patrick AFB, FL 32925	2	HQDA (DARD-PPI, Mr. Birra), Wash, DC 20330
	AFISC, Norton AFB, CA 92409	3	Comdr, USAMatComd (AMCRD-U), 5001 Eisenhower Ave, Alexandria, VA 22333
1	(PQAL)		
1	(SE)	3	Comdr, USAT&EComd (AMSTE-SE; AMSTE-AD), Aberdeen Pvg Gnd, MD 21005
1	Dir Nuc Safety (SN), Kirtland AFB, NM 87117		
	AFSC, Andrews AFB, Wash, DC 20334	1	Comdr, USATRADO (ATCD-FT), Ft Monroe, VA 23651
2	(DO)	1	Comdr, USAFOPSCOM (AFOP-RE), Ft McPherson, GA 30330
1	(XRP)		
1	TAC (DOA), Langley AFB, VA 23365		Comdr, USAArmComd, Rock Island, IL 61201
	CINCSAC, Offutt AFB, NE 68113	1	(AMSAR-R)
1	(DOXS)	1	(AMSAR-RDG)
1	(XPFC)	1	(AMSAR-CP)
1	ADC (DOA), Ent AFB, CO 80912		Comdr, USAEC, Ft Monmouth, NJ 07703
1	AUL (LDE), Maxwell AFB, AL 36112	1	(AMSEL-RD-1)
		1	(AMSEL-WL-N)
1	AFIT (Tech Lib, B640, A-B), Wright-Patterson AFB, OH 45433	1	Comdr, USAASys Comd (AMSAV-EFI), P. O. Box 209, St Louis, MO 63166
1	CINCUSAFE (DOA), APO New York 09012	1	Comdr, OT&EAgcy (FDTE-PO-OB), Ft Belvoir, VA 22060
1	CINCPACAF (DOA), APO San Francisco 96553	1	Comdr, CACDA (ATCACC-CA), Ft Leavenworth, KS 66027
1	USAFA (DFSLB), CO 80840	2	Comdr, USAADC, Ft Bliss, TX 79916
1	MAC (DOOAS), Scott AFB, IL 62225	2	HITVAL TD, P. O. Box 6114, Ft Bliss, TX 79906
1	12 AF (DO), Bergstrom AFB, TX 78743	1	Pres, ADB (C. French), Ft Bliss, TX 79916
1	AFFDL (Lib), Wright-Patterson AFB, OH 45433	2	Comdr (STEWS-TE-ML; STEWS-NR-PA), WSMR, NM 88002
	ASD, Wright-Patterson AFB, OH 45433		Dir, USABRL, Aberdeen Pvg Gnd, MD 21005
1	(Tech Lib)	2	(AMXBR-XD; AMXBR-CA)
1	(XR)	2	(AMXBR-EB; AMXBR-TB)

No. cys

1 ESD (Tech Lib), Hanscom
AFB, MA 01730

1 AFATL (Tech Lib), Eglin
AFB, FL 32542

ADTC, Eglin AFB, FL 32542

1 (Tech Lib)

1 (TGPE)

1 (TSGG)

AFSWC, Kirtland AFB, NM
87117

1 (HO, Dr. Minge)

5 (FTH)

2 AFTEC (JT), Kirtland AFB,
NM 87115

AFWL, Kirtland AFB, NM
87117

2 (SUL)

1 (EL)

1 (SA)

1 (IN)

1 AFOSR, 1400 Wilson Blvd,
Arlington, VA 22209

TAWC, Eglin AFB, FL 32544

2 (TAS)

1 (OA)

1 FTD (FAMF), Wright-Patter-
son AFB, OH 45433

1 49 TACFW, Holloman AFB, NM
88330

1 Ofc Ch, Nav Op, Dept Navy,
Wash, DC 20350

1 ONR (Code 418), Dept Navy,
Wash, DC 20360

1 Dir, NRL (Code 2027),
Wash, DC 20390

1 Comdg Off/Dir, NEL (Code
4223), San Diego, CA 92152

1 Comdr, NWC (Code 753), China
Lake, CA 93557

1 Comdr, NOL (Code 730), White
Oak, Silver Spring, MD
20910

1 Dir, SpPrOfc, Dept Navy,
Wash, DC 20360

No. cys

5 Dir, USAMSAA, Aberdeen Pvg
Gnd, MD 21005

2 Comdr, USAMTD (STEAP-MT-M),
Aberdeen Pvg Gnd, MD 21005

1 MASSTER (ATMAS-OEP-Q), Ft
Hood, TX 76544

1 Comdr, USAFS&TC (AMXST-CB1),
220 7th St NE, Charlottes-
ville, VA 22901

3 ODDR&E (TSTE), Rm 3E1081,
Pentagon, Wash, DC 20301

2 Comdr, Wpns Sys Eval Gp (Col
Spencer), 400 Army-Navy Dr,
Arlington, VA 22202

4 Dir, DIA (DC-4B; DIAAP-8B;
DIAST-3), Wash, DC 20301

2 DDC (TCA), Cameron Sta, Alex-
andria, VA 22314

1 Dir, HUMRRO (Dr. Baldwin),
P. O. Box 31249, El Paso, TX
79931

3 Dir, IDA (Dr. Ross), 400 Army-
Navy Dr, Arlington, VA 22202

1 SWRI (Dr. Baker), 8500 Culebra
Rd, San Antonio, TX 78284

1 EG&G (R. Chaney), 9733 Coors
Rd NW, Albuquerque, NM 87114

1 VITRO Corp, P. O. Box 39,
Port St Joe, FL 32456

1 MAAG (Maj F. Breslin, GS),
MAAG Box 340, APO New York
09080

1 Official Record Copy (Mr.
Sweeney, AFSWC/FTH)