

UNCLASSIFIED

AD NUMBER

ADB005321

LIMITATION CHANGES

TO:

Approved for public release; distribution is unlimited.

FROM:

Distribution authorized to U.S. Gov't. agencies only; Test and Evaluation; 30 APR 1975. Other requests shall be referred to Military Traffic Management Command, Attn: MTMC-SA, Washington, DC 20315.

AUTHORITY

mtmc, d/a ltr, 4 may 1983

THIS PAGE IS UNCLASSIFIED

THIS REPORT HAS BEEN DELIMITED
AND CLEARED FOR PUBLIC RELEASE
UNDER DOD DIRECTIVE 5200.20 AND
NO RESTRICTIONS ARE IMPOSED UPON
ITS USE AND DISCLOSURE.

DISTRIBUTION STATEMENT A

APPROVED FOR PUBLIC RELEASE;
DISTRIBUTION UNLIMITED.

AD

2

ADB005321

MTMC REPORT 75-16
AN ANALYSIS
OF THE INITIAL DEPLOYMENT
OF A US ARMY UNIT
BY A BARGE-SHIP SYSTEM

By
WILLIAM H. SCANLAN, LTC, TC

APRIL 1975

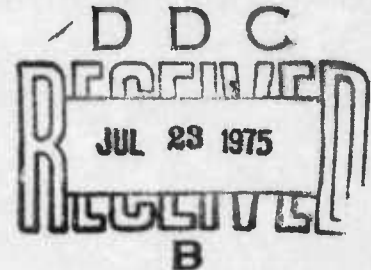

MILITARY TRAFFIC MANAGEMENT COMMAND
TRANSPORTATION ENGINEERING AGENCY
NEWPORT NEWS, VIRGINIA 23606

Distribution limited to US Government agencies only; test and evaluation of commercial products and military hardware (30 April 1975). Other requests for this document must be referred to Commander, Military Traffic Management Command, ATTN: MTMC-SA, Washington, DC 20315.

DISCLAIMER NOTICE

The findings in this report are not to be construed as an official Department of the Army position, unless so designated by other authorized documents.

* * * * *

DISPOSITION INSTRUCTIONS

Destroy this report when it is no longer needed. Do not return it to the originator.

* * * * *

Trade names cited in this report do not constitute an official indorsement or approval of the use of such commercial hardware or software.

AD

MTMC REPORT 75-16

AN ANALYSIS OF THE INITIAL DEPLOYMENT OF A
US ARMY UNIT BY A BARGE-SHIP SYSTEM

April 1975

Project Officer

William H. Scanlan, LTC, TC

Contributors

Anthony Arko, CPT, TC
George H. Carroll
Robert Dienes
Graydon T. Gosling
Orville P. Stokes, MAJ, TC
Henry B. Wolfe

MILITARY TRAFFIC MANAGEMENT COMMAND
TRANSPORTATION ENGINEERING AGENCY
Newport News, Virginia 23606

Distribution limited to US Government agencies only; test and evaluation of commercial products and military hardware (30 April 1975). Other requests for this document must be referred to Commander, Military Traffic Management Command, ATTN: MTMC-SA, Washington, DC 20315

ABSTRACT

This study is a conceptual analysis of ways and means to improve the oversea transportability of US Army units and equipment in both peacetime and contingency situations with the modern sealift assets presently available. Its objectives are to provide a documentary narrative of the initial use of a barge-ship system to deploy a US Army tactical unit and to identify technical and operational shortcomings in order to recommend improvements in the state of the art. It was found that the responsiveness, efficiency, and economy of US Army oversea unit moves, especially those deploying with helicopters, could be significantly improved by implementing the conceptual loadings and use of the barge-ship systems.

ACKNOWLEDGMENT

The following organizations are acknowledged for their invaluable assistance during the conduct of this study: US Army Aviation Systems Command, Saint Louis, Missouri; Avondale Shipyards; Friede and Goldman Naval Architects; Lykes Bros. Steamship Company; Central Gulf Lines; Delta Steamship Lines; Waterman Steamship Corporation; and the Gulf Outport, Military Traffic Management Command (MTMC), New Orleans, Louisiana; Prudential-Grace Lines, Inc. in New York, New York, and Norfolk, Virginia; Bell Helicopter Company; Seatrain Lines, Inc.; Military Sealift Command; and MTMC Headquarters, Washington, DC; US Naval Air Station Pensacola, Florida; and the US Army Transportation Command, Europe.

FOREWORD

After observing the peacetime outloading of the 175th Aviation Company (Attack Helicopter) by the Sea Barge (SEABEE) system in early 1973, the Military Traffic Management Command Transportation Engineering Agency (MTMC TEA) developed AH-1G helicopter loading concepts for increasing the efficiency of SEABEE barge cube utilization. These concepts were expanded later in 1973 to include other Army helicopters and Lighter Aboard Ship (LASH) lighters in response to a US Readiness Command request to analyze the contingency movement of an airmobile division. The study report, published in mid-1974, recommended testing of the proposed helicopter loadings in the barge-ship systems. In late 1974, the Office of the Deputy Chief of Staff for Logistics, Department of the Army (DA), tasked the Training and Doctrine Command (TRADOC) to conduct the tests which are tentatively planned for Fiscal Year 1976. Similar conclusions and recommendations are retained in this report to maintain documentary continuity, since publication was delayed to complete the higher priority airmobile division study and other requested follow-on analyses.

TABLE OF CONTENTS

	<u>Page</u>
ABSTRACT	iii
ACKNOWLEDGMENT	iv
FOREWORD	v
LIST OF ILLUSTRATIONS	vii
Section I. SUMMARY, CONCLUSIONS, AND RECOMMENDATIONS	1
II. INTRODUCTION	3
III. BARGE-SHIP SYSTEMS	9
IV. UNIT DEPLOYMENT	22
V. DEPLOYMENT ANALYSIS	49

LIST OF ILLUSTRATIONS

<u>Figure</u>		<u>Page</u>
1	C4 Break-Bulk (Freighter) Ship	4
2	Seatrain Puerto Rico Class Ship - Specially Configured for Military Cargo	5
3	US Army Aircraft Aboard US Navy Aircraft Carrier . .	5
4	US Navy TAKV Aircraft Transport	6
5	US Army Helicopters Aboard Seatrain Vessel	7
6	Sea Barge (SEABEE) Ship	10
7	Two Barges on SEABEE Stern Elevator	12
8	View of SEABEE Stern	13
9	Barges Stowed on SEABEE Lower Deck	14
10	SEABEE Barge Characteristics	15
11	Size Comparison of LASH Lighter to SEABEE Barge	15
12	Overstowed Containers in SEABEE Barge	16
13	Lighter Aboard Ship (LASH)	18
14	LASH Lighter Being Lifted Aboard	19
15	LASH Gantry Crane Stowing Lighter	19
16	Container Crane Aboard Some LASH Ships	20
17	LASH Lighter Characteristics	21
18	AH-1G Cobra Helicopter	23
19	AH-1G Helicopter Preserved for Below Deck Sea Shipment	24

LIST OF ILLUSTRATIONS - cont

<u>Figure</u>		<u>Page</u>
20	Mobile Crane Removing SEABEE Barge Hatch Cover	25
21	Loading AH-1G Cobras Aboard SEABEE Barge With Modified Bow	25
22	AH-1G Helicopter Tiedowns to SEABEE Barge Side Bulkhead Fittings	26
23	AH-1G Helicopter Tiedowns to SEABEE Barge Forward Bulkhead Fittings	27
24	Braces Unitize Stow of AH-1G Helicopters in SEABEE Barge	28
25	AH-1G Helicopter Jack/Tiedown Fittings	28
26	Lack of Deck Tiedown Fittings Required Long Cable Runs to SEABEE Barge Side Bulkhead Fittings	29
27	Padding Affixed to Helicopters To Protect Against Possible Cable Interference.	30
28	UH-1H Huey Helicopter Forward Jack/Tiedown Fitting.	31
29	UH-1H Huey Helicopter Aft Jack/Tiedown Fittings	31
30	Helicopter Vertical Clearance From SEABEE Barge Hatch Covers.	32
31	Rotor Blade Containers Stowed in SEABEE Barge	33
32	Berthing SEABEE Barge at Army Pier in Mobile, Alabama	34
33	Improperly Decubed Forklift Truck Being Loaded Aboard SEABEE Barge	35

LIST OF ILLUSTRATIONS - cont

<u>Figure</u>		<u>Page</u>
34	Stowage of 11 Military Vehicles in SEABEE Barge	36
35	Views of Vehicle Lashings to SEABEE Barge End Bulkhead Fittings	37
36	Views of Vehicle Wheel Blocking in SEABEE Barge	39
37	Intervehicle Lashings Unitized Stow in SEABEE Barge	40
38	Overstow of High-Density Military Cargo in SEABEE Barge	41
39	SEABEE Ship Docking at Rotterdam, Holland	42
40	Dutch Tugboats Discharge SEABEE Barges	43
41	Rhine River System	44
42	SEABEE Barges Transiting Rhine River	45
43	Helicopter Unloading at US Army Rhine River Terminal	46
44	CH-54A Sky Crane Helicopter Transporting AH-1G Cobra	47
45	Two AH-1G and Two UH-1H Helicopters Loaded in SEABEE Barge	50
46	Three Unpreserved Civilian Helicopters Shipped in SEABEE Barge	50
47	Civilian Helicopters Unloaded From SEABEE Barges Onto Galveston, Texas, Dock and Flown Away	51
48	Stowage of Six AH-1G Helicopters in SEABEE Barge	53

LIST OF ILLUSTRATIONS - cont

<u>Figure</u>		<u>Page</u>
49	Stowage of 10 AH-1G Helicopters in SEABEE Barge	55
50	AH-1G Helicopter Air Transportability Tiedown Fitting	56
51	Stowage of 14 AH-1G Cobras in SEABEE Barge	57
52	AH-1G Helicopter Air Transportability Skid	58
53	AH-1G Cobra Rigged for Airlift on Air Transportability Skid	58
54	Installation Diagram of Tiedown Fittings for 14 AH-1G Helicopters in SEABEE Barge	59
55	Loading Sequence and Tiedown Diagram for 14 AH-1G Helicopters in SEABEE Barge	60
56	Stowage of Eight AH-1G Helicopters in LASH Lighter	61
57	Installation Diagram of Tiedown Fittings for Eight AH-1G Helicopters in LASH Lighter	62
58	Loading Sequence and Tiedown Diagram for Eight AH-1G Helicopters in LASH Lighter	63
59	Military Equipment Aboard Seatrain Vessel	64
60	M48 Tanks Being Loaded in LASH Lighter	65
61	105-mm Ammunition Loaded in LASH Lighter	65
62	Loading 54 1/4-Ton Utility Trucks in LASH Lighter	66
63	Ohio and Mississippi River Systems	68
64	AH-1G Helicopters Being Loaded Aboard Seatrain Vessel	70

SECTION I

SUMMARY, CONCLUSIONS, AND RECOMMENDATIONS

1. Terms of Reference. This study is a conceptual analysis of ways and means to improve the oversea transportability of US Army units and equipment in both peacetime and contingency situations with the modern sealift assets presently available. Its objectives are to provide:

a. A documentary narrative of the initial use of a barge-ship system for the oversea movement of the weapon systems and equipment of a US Army tactical unit.

b. A detailed analysis of this significant unit deployment in order to identify transportability technical and operational shortcomings, and to recommend improvements in the state of the art in these areas.

2. Approach. The approach taken in this study is an aggressive, experimental exploration of standard and nonstandard techniques and procedures for loading Army helicopters and military equipment in the barge-ships available now and in the future. Then a comparative analysis is made of two combination rail/sea deployments of similar units by different types of ships and a potential deployment by only a barge-ship system.

3. Conclusions.

a. General.

(1) The oversea transportability of US Army units in both peacetime and contingency situations could be significantly improved by implementing the proposed ship-loading procedures with the modern sealift assets presently available.

(2) The proposed helicopter loadings in the barge-ship systems represent a significant advance in the state of the art and should be confirmed.

b. Specific.

(1) The responsiveness, efficiency, and economy of US Army oversea unit moves, especially those deploying with helicopters, could be improved by use of the barge-ship systems as follows:

(a) Immediate loading from dock to barge of minimally preserved and disassembled helicopters.

(b) Test-confirmed methodology to increase density of helicopter loads in barges.

(c) Full use of the barge-ship systems when time permits inland river origin port to destination port service to reduce or eliminate intermodal transfers.

(2) With the deactivation of Seatrain vessels normally used for semiprotected transport of US Army aircraft, the nonavailability of suitable US Navy helicopter transport ships, and the limited number of roll-on/roll-off ships, it is critical that the helicopter transportability concepts be verified by loading tests of the barge-ship systems.

4. Recommendations. It is recommended that -

a. Expedited testing be conducted of the proposed helicopter loadings in the barge-ship systems.

b. The concepts proposed in this study be approved as a basis for the development of plans, procedures, and systems necessary to permit the rapid deployment of US Army units in a contingency situation and the optimum transportability of Army aircraft in peacetime.

SECTION II

INTRODUCTION

1. Purpose. To improve the oversea transportability of US Army units in both peacetime and contingency situations with the modern sealift assets presently available.

2. Objectives. To provide:

a. A documentary narrative of the initial use of a barge-ship system,^{1/} the Sea Barge (SEABEE), for the oversea movement of the weapon systems and equipment of a US Army tactical unit.

b. A detailed analysis of this significant unit deployment in order to identify transportability technical and operational shortcomings, and to recommend ways and means to improve the state of the art in these areas.

3. Scope. This study is basically limited to the deployment of the 175th Aviation Company (Attack Helicopter) from Fort Knox, Kentucky, to Illesheim, Germany, in January and February, 1973. However, a comparative analysis with a similar unit move by another type of shipping is included. Additionally, other concepts and a potential deployment are discussed.

4. Background.

a. This study was initiated by the Military Traffic Management Command (MTMC), after observing the peacetime movement of the 175th Aviation Company, in keeping with its mission to monitor transportation concepts, policies, and procedures to insure responsiveness, efficiency, and economy. The findings and concepts that resulted from this analysis were the basis for a subsequent study of an airmobile division simulated contingency deployment,^{2/} which was initiated in July 1973 at the request of the US Readiness Command (USREDCOM). The publication of this higher priority airmobile division study, subsequent Department of the Army

^{1/} MTMTS Report 73-33, Barge-Ship Systems (BSS) Study, Military Traffic Management and Terminal Service, Washington, DC 20315, December 1973.

^{2/} MTMTS Report 74-19, An Analysis of Simulated Deployment of the US Army Airmobile Division, Military Traffic Management and Terminal Service, Washington, DC 20315, May 1974.

(DA) staff coordination, and attendant information briefings delayed the completion and publication of this significant documentary study.

b. Military units have traditionally been deployed by break-bulk (freighter) ships, which offer great versatility for military cargoes (Figure 1). Since 1966, Seatrain vessels specially modified to transport military cargo have also been used extensively (Figure 2). Aircraft have been transported by US Navy aircraft carriers (such as the USS Boxer when the 1st Cavalry Division deployed to the Republic of Vietnam in 1965) (Figure 3), US Navy TAKV aircraft transports (Figure 4), the specially modified Seatrain vessels (Figure 5), and, when necessary, even by freighters. However, in the last decade, the makeup of sealift assets has changed significantly. US Navy aircraft carriers are heavily committed for combat missions, there are no TAKV aircraft transports in operation or in the reserve fleet, and all of the modified Seatrain vessels have been deactivated and placed in the reserve fleet. Additionally, as the old Government-owned break-bulk cargo ships wear out from the heavy demands of the recent Southeast Asian conflict, they are being scrapped without replacement. Modern ocean shipping is predominantly in containerships, with a small number of roll-on/roll-off (RORO) ships and barge-ships. Designed to transport wheeled and tracked vehicles, RORO vessels can also stow aircraft on the top deck and on some of the lower decks. The man-hours and cost of the required preservation could be significantly reduced by use of new type, one-piece protective covers being developed by the US Army Aviation Systems Command (AVSCOM).

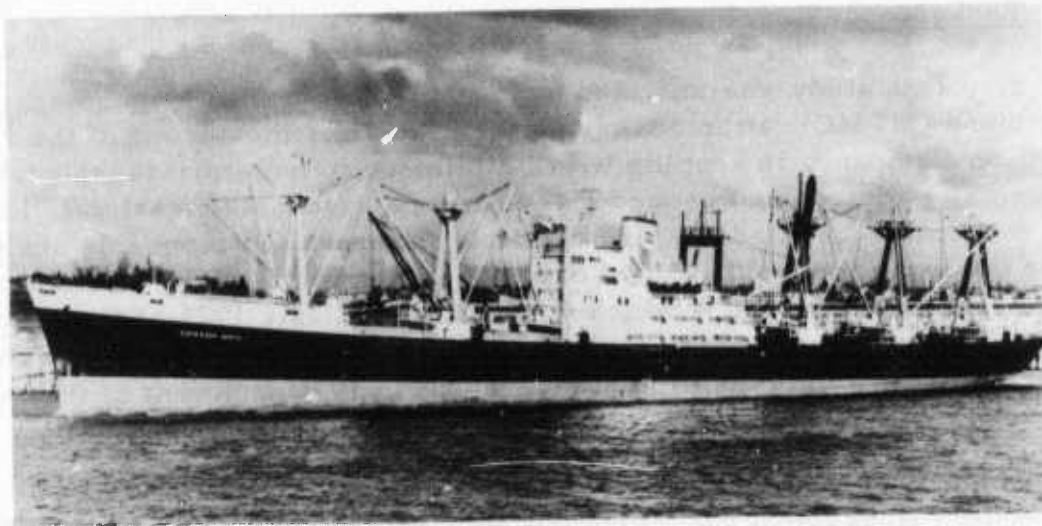

Figure 1. C4 Break-Bulk (Freighter) Ship.

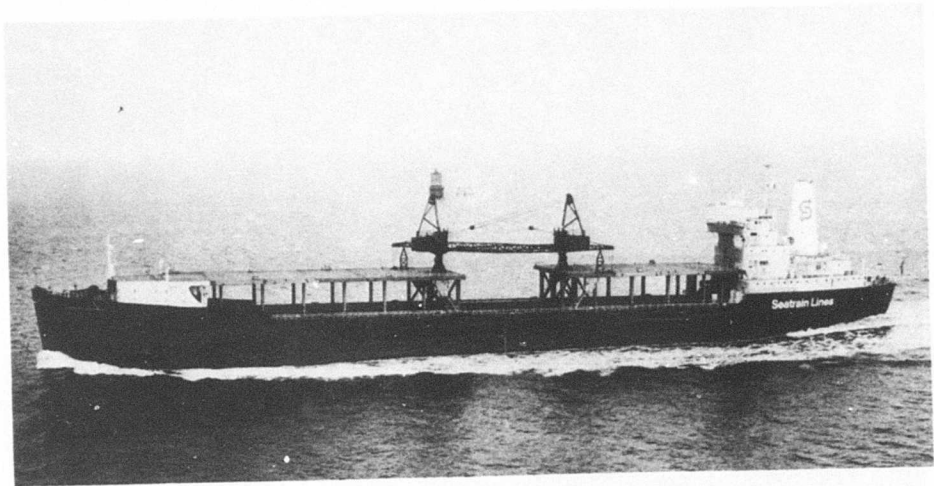

Figure 2. Seatrain Puerto Rico Class Ship - Specially Configured for Military Cargo.

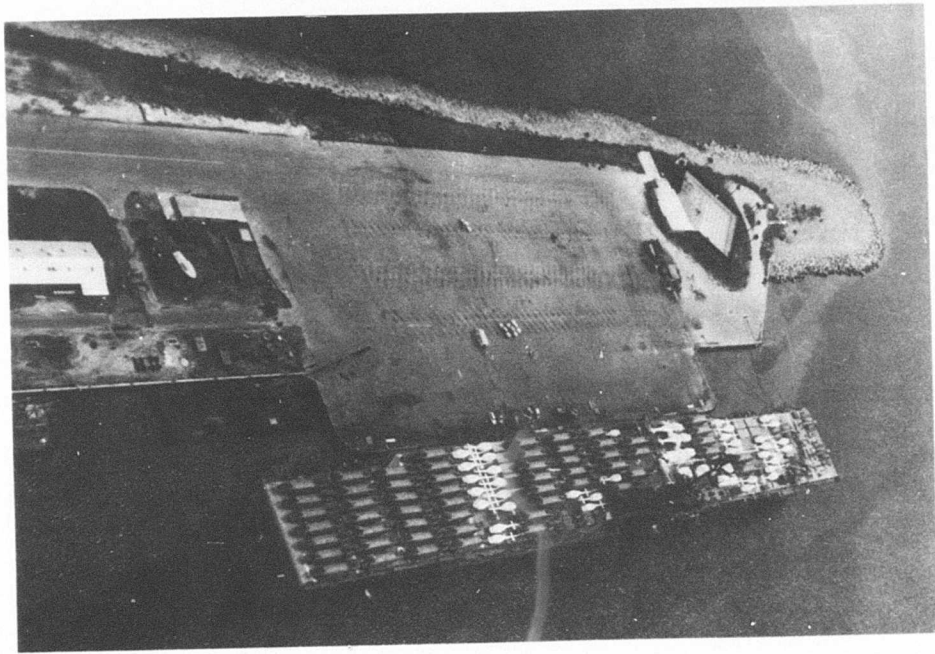

Figure 3. US Army Aircraft Aboard US Navy Aircraft Carrier.

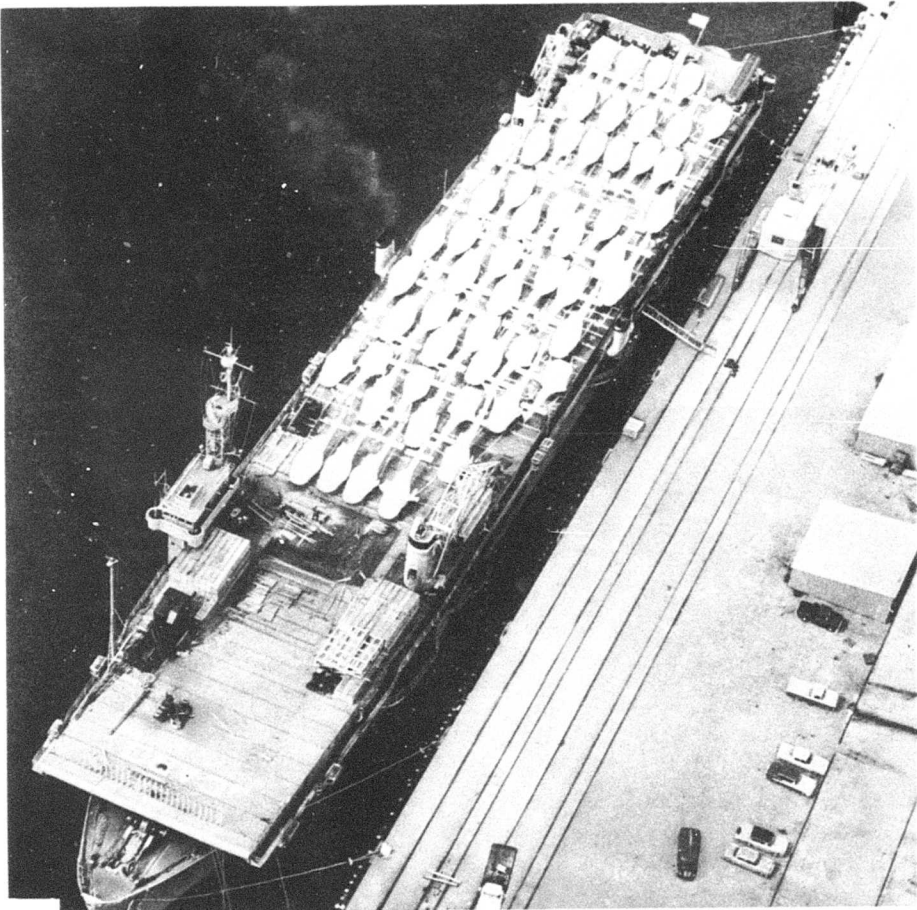

Figure 4. US Navy TAKV Aircraft Transport.

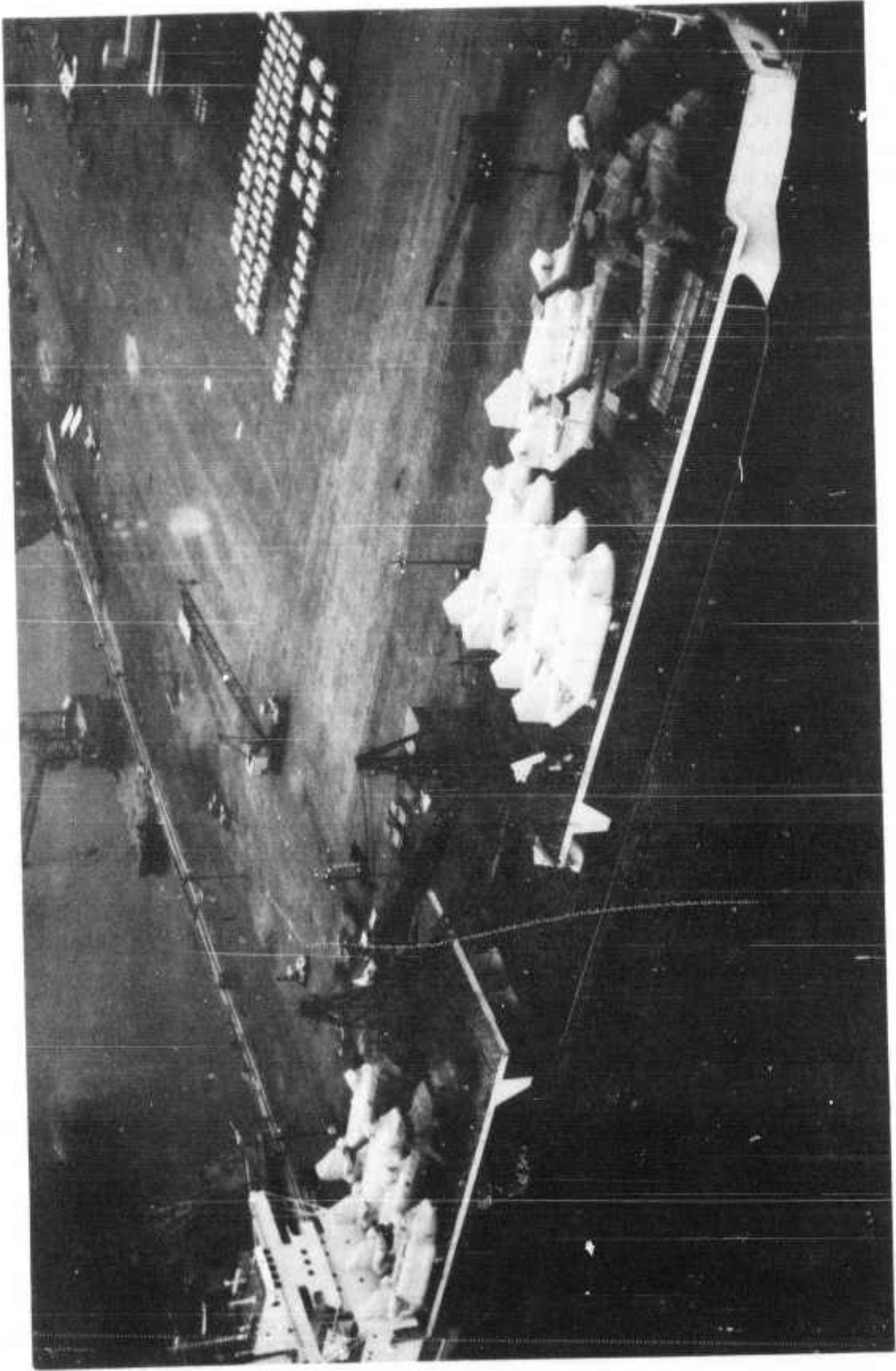

Figure 5. US Army Helicopters Aboard Seatrain Vessel.

c. Independent comparative analyses conducted by both MTMC^{3/-7/} and the US Army Mobility Equipment Command (MECOM)^{8/,9/} in 1971 and 1972 concluded that the SEABEE barge-ship system represented the most versatile multimission capability available to satisfy military requirements for sealift of military materiel during a contingency. The SEABEE ship can carry all items of equipment organic to Army units. Unfortunately, there are only three of these militarily advantageous ships available today and no known US construction projected.

d. Normally, the 175th Aviation Company (AM) would have been transported by a Seatrain vessel. However, the unit's required date to close in Germany precluded the routine scheduling of a Seatrain. Therefore the Gulf Outport, MTMC, requested that the Military Sealift Command (MSC) use the available SEABEE system as a test move.

e. MTMC observed and recorded the SEABEE barge loadings of the helicopters at the US Naval Air Station, Pensacola, Florida, and the unit equipment at Mobile, Alabama. Other pertinent data were obtained from Government agencies and oversea commands.

^{3/} USATEA Report 71-15, Unit Deployment by Container/Containership (UDC), Volumes I - IV, MTMTS, May 1971.

^{4/} USATEA Report 71-22, Analysis of a Force Deployment Via Shipping - 1976 Time Period (AFD), MTMTS, June 1971.

^{5/} USATEA Report 71-40, Analysis of a Force Deployment Via Shipping - 1976 Time Period (Phase IIA) (AFD-11A), MTMTS, July 1971.

^{6/} USATEA Report 71-41, Analysis of a Force Deployment Via Barge-Carrying Ships (AFD-BS), MTMTS, August 1971.

^{7/} USATEA Report 71-39, Utilization of Flat Racks in Force Deployments (UFR), MTMTS, November 1971.

^{8/} USAMECOM Report, Comparative Analysis of the Multi-Mission Ships (MMS) and Multi-Purpose Ship (MPS), prepared by Special Projects Office, USAMECOM, Norfolk, VA, September 1971.

^{9/} USAMECOM Study, Study of National Defense Features for US Merchant Vessels, prepared by Special Projects Office, USAMECOM, Norfolk, VA, August 1972.

SECTION III

BARGE-SHIP SYSTEMS

1. General.

a. There are two barge-ship systems - Lighter Aboard Ship (LASH) and Sea Barge (SEABEE). Each system has two primary components: a mother ship and a family of lighters or barges, both commonly called barges. Both ships can load or discharge their barges by using lifting devices at the stern at either an off-shore anchorage or at an established port. Both systems are compatible with worldwide inland waterway systems. Although similar in many ways, the physical characteristics of the two systems result in a number of differences that become significant when planning their optimum use for transporting military units.

b. The dimensions and pertinent characteristics of the mother ships are as follows:

	<u>SEABEE</u>	<u>C8 LASH</u>	<u>C9 LASH</u>
Length:	874 ft	820 ft	893 ft
Width:	106 ft	100 ft	100 ft
Deadweight (max):	38,410 LTON	29,820 LTON	39,100 LTON
Draft (max):	39 ft	35 ft	37 ft
Draft (mil op):	28 ft	28 ft	30 ft
Deadweight (mil op):	18,300 LTON	17,800 LTON	25,600 LTON
Engine:	36,000 SHP	32,000 SHP	32,000 SHP
Speed (mil op):	21.7 knots	22.5 knots	22.5 knots
Dry Cargo:	44,350 MTON	37,900 MTON	43,550 MTON

2. SEABEE (Figure 6)

a. The SEABEE ship can efficiently carry noncontainerizable vehicles and other cargo in large quantities in barges or on barge decks. Additionally, it can carry containerized cargo in and on top of barges. The SEABEE is the only modern ship that can carry the aircraft of Army

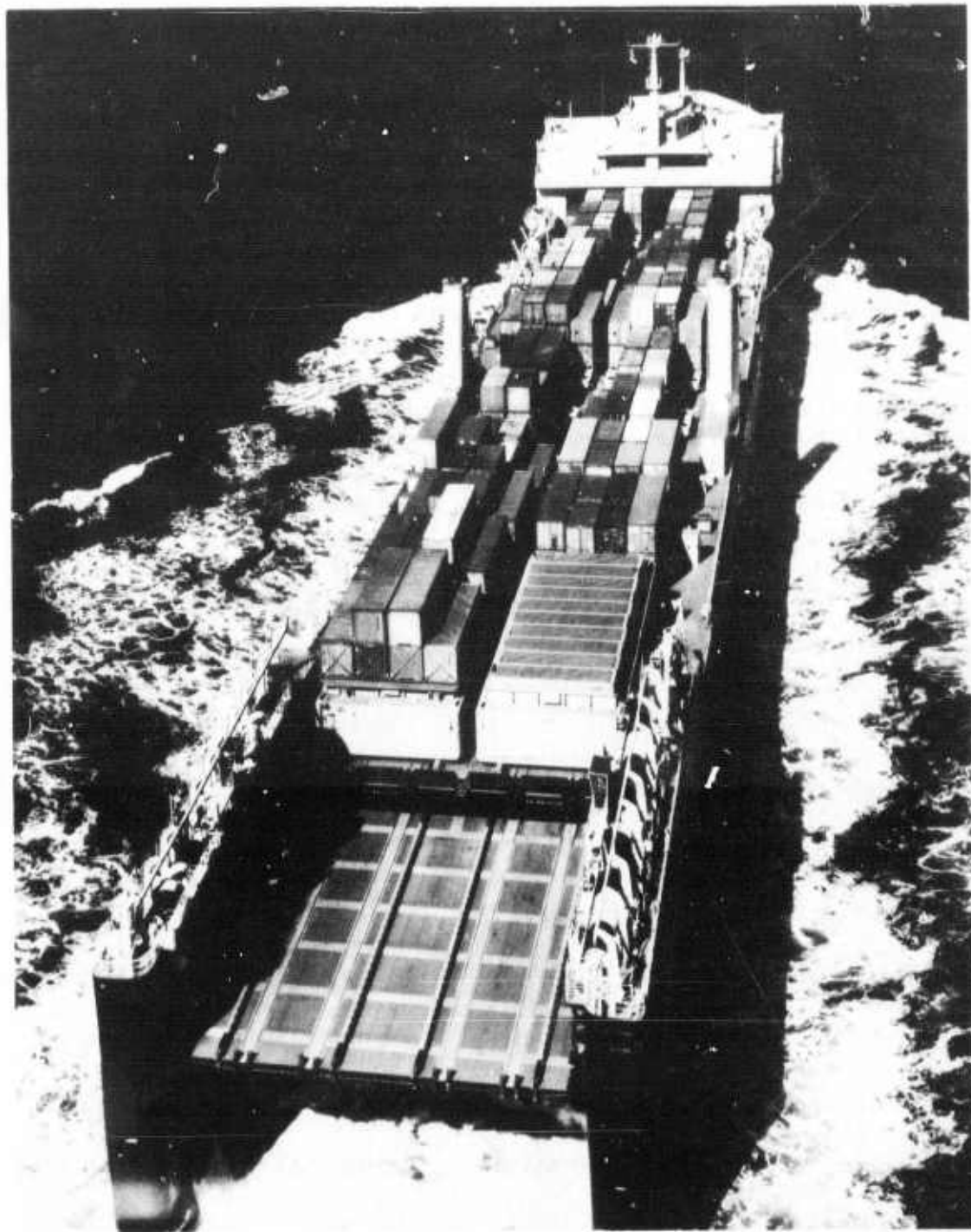

Figure 6. Sea Barge (SEABEE) Ship.

units without extensive sectionalization. With relatively minor modifications, the ship is capable of carrying 1,784 20-foot equivalents (TEU) in a pure containership configuration. Also, the SEABEE could be configured to provide 146,000 square feet of deck space for use in RORO operations. The 200-foot unobstructed deck area between the deckhouse and stacks provides a suitable landing area for helicopters. Below the lower barge deck the ship is essentially a tanker with a capacity of 1,270,000 cubic feet presently fitted for 30,100 long tons (LTON) of salt water ballast plus 5,780 LTON of fuel oil. The tanks may be fitted out as required to carry ballast, fuel oil, and/or liquid cargoes. This tank capacity may be particularly useful in military applications.

b. Dry cargo is carried in 38 barges and up to 160 40-foot containers. The barges are stored horizontally on each of three decks; 12 each on the main and lower decks and 14 on the upper deck. The unique feature of the SEABEE ship is the 2,000-LTON-capacity submersible stern elevator, which is capable of lifting or lowering two fully loaded barges simultaneously (Figure 7). Barges are transferred from the elevator platform to one of three decks by means of two barge transporters (Figure 8). The 100-foot automated transporters consist of a series of motorized dollies with hydraulic power units to raise and lower the barges (Figure 9). Under ideal conditions, the SEABEE can handle two barges across the elevator every 40 minutes. Theoretically, it could load or discharge in 13 hours.

c. The watertight, double-hulled SEABEE barge (Figure 10) is the same width and one-half the length of the standard US commercial river barge. It is larger (Figure 11) and has approximately twice the cargo-carrying capacity of the LASH lighter. The flexibility of the barge is its most noteworthy feature:

(1) A second deck, full or partial, can be installed using integral flat racks athwartships.

(2) By using supports readily attached to integral side bulkhead fittings, up to 10 30-foot containers can be stowed athwartships above low profile cargo such as small vehicles (Figure 12).

(3) By attaching three prefabricated supports, up to 16 40-foot containers can be carried atop 10 of the 14 loaded barges stowed on the upper deck. This feature increases the cubic carrying capacity of each barge from approximately 978 to 1,927 MTON. The barges are readily accessible during a voyage by catwalks in the ship and manhole hatches in the barges. Each barge is fitted for smoke monitoring as well as carbon dioxide and water fire-extinguishing systems. Ventilation by forced draft is also provided underway.

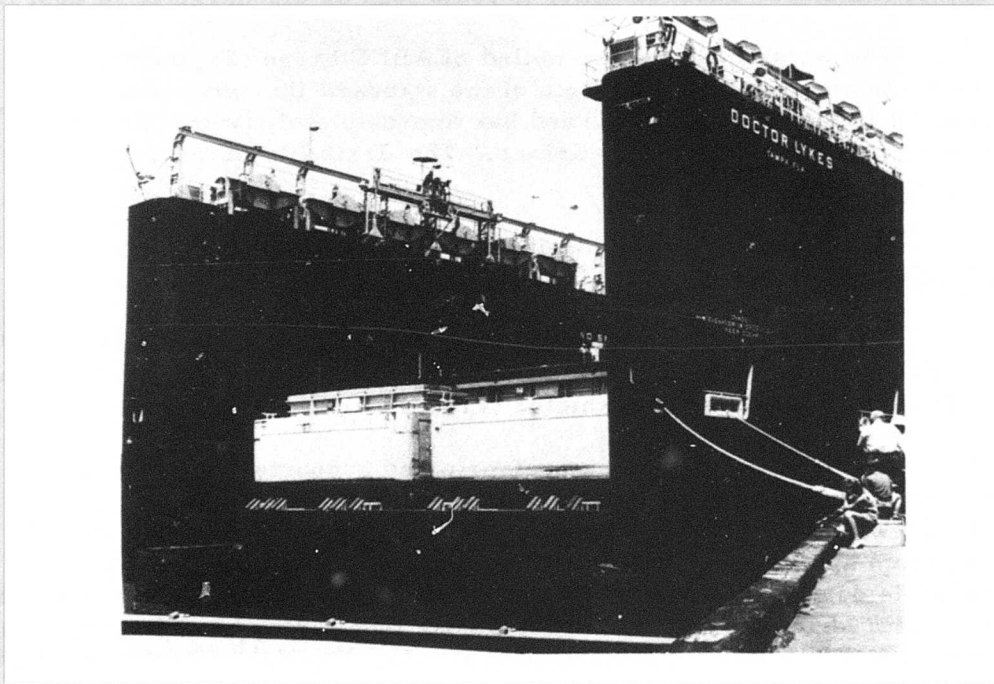
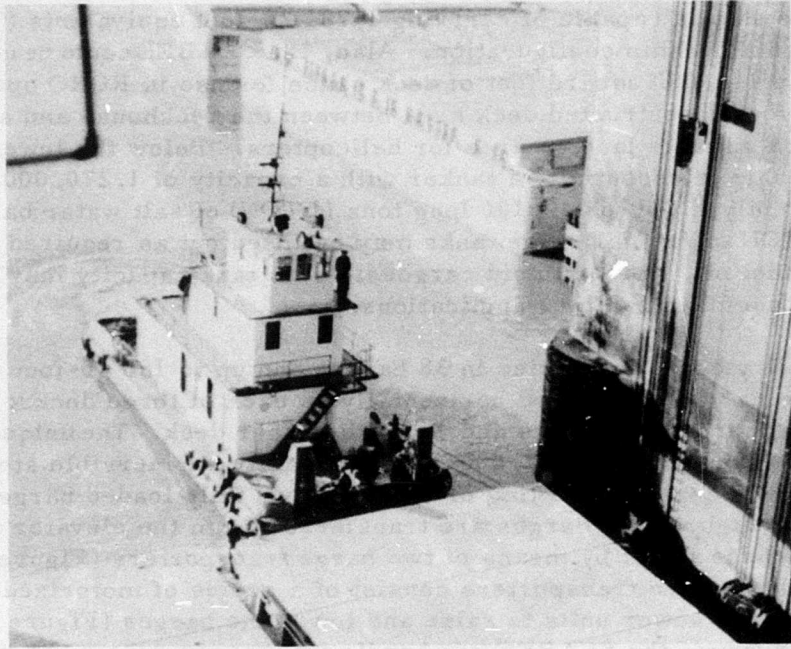

Figure 7. Two Barges on SEABEE Stern Elevator.

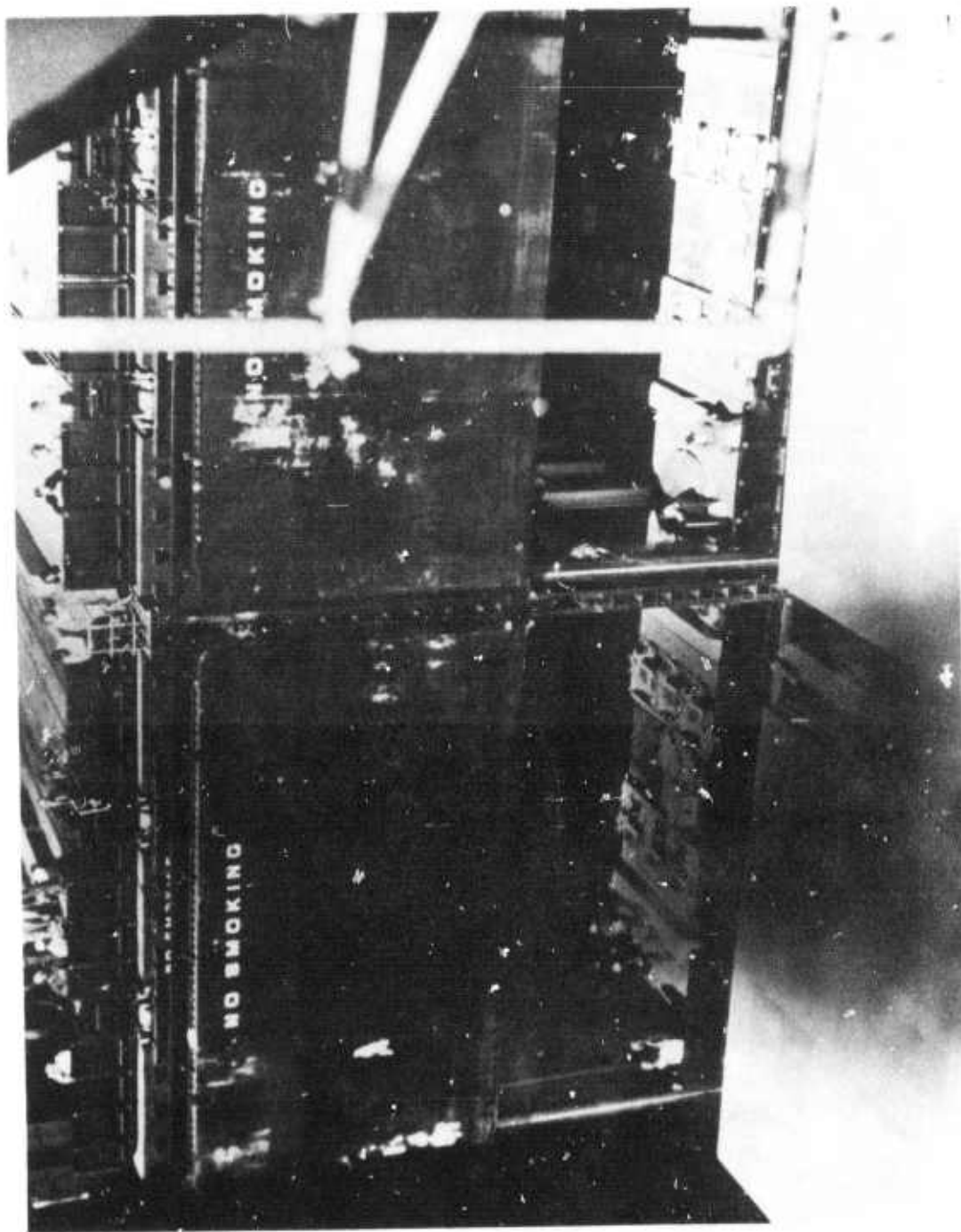

Figure 8. View of SEABEE Stern.

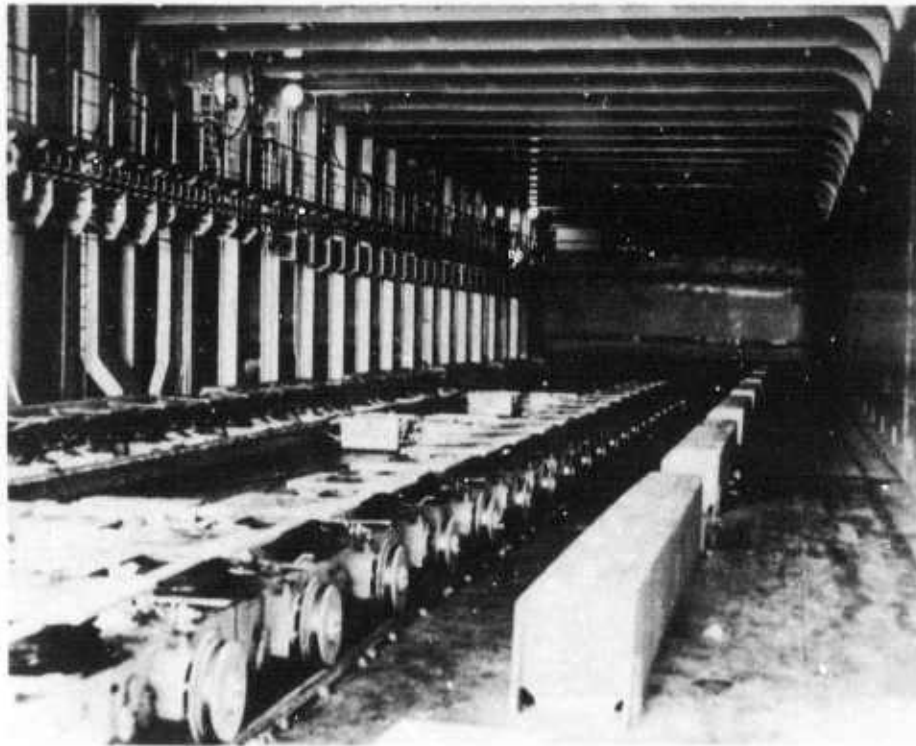
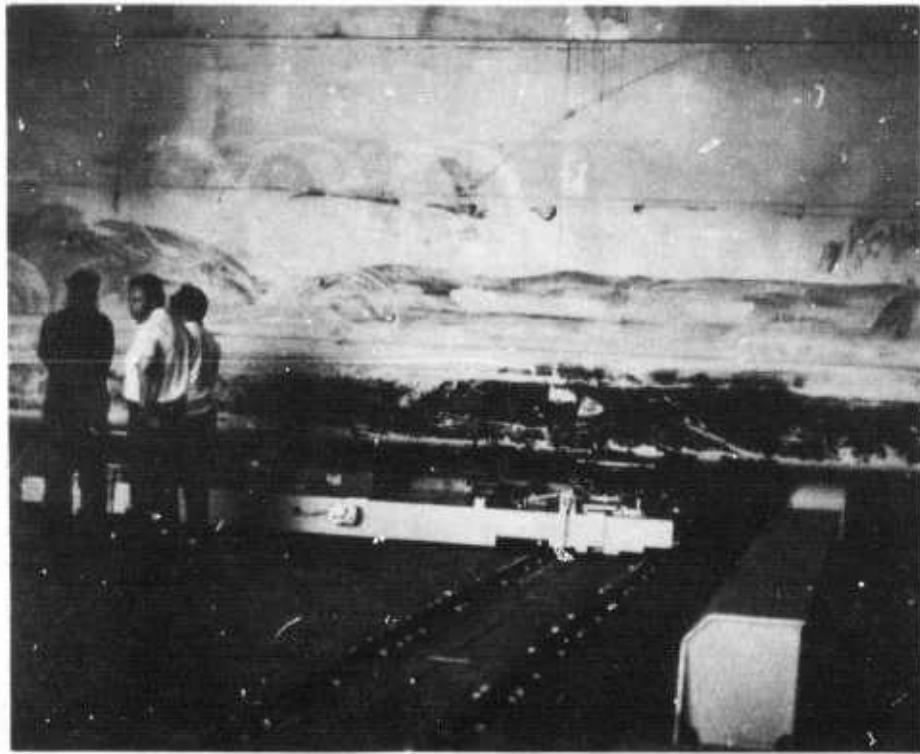
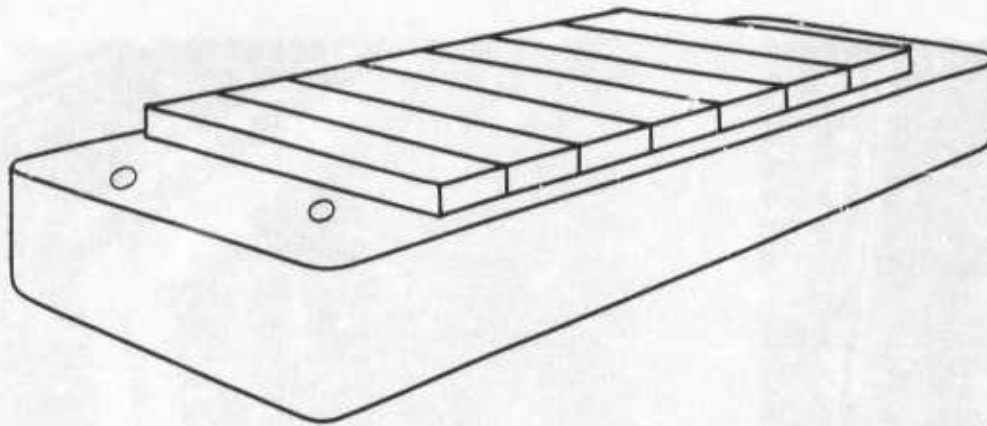

Figure 9. Barges Stowed on SEABEE Lower Deck.



Hatch Panels: 7 ea, approx 5,800 lb per panel
 Cargo Capacity: 834 LTON/39,140 cu ft
 Empty Draft: 1'9"
 Fully Loaded Draft: 10'7"
 Lightweight Barge: 150 LTON

Figure 10. SEABEE Barge Characteristics.

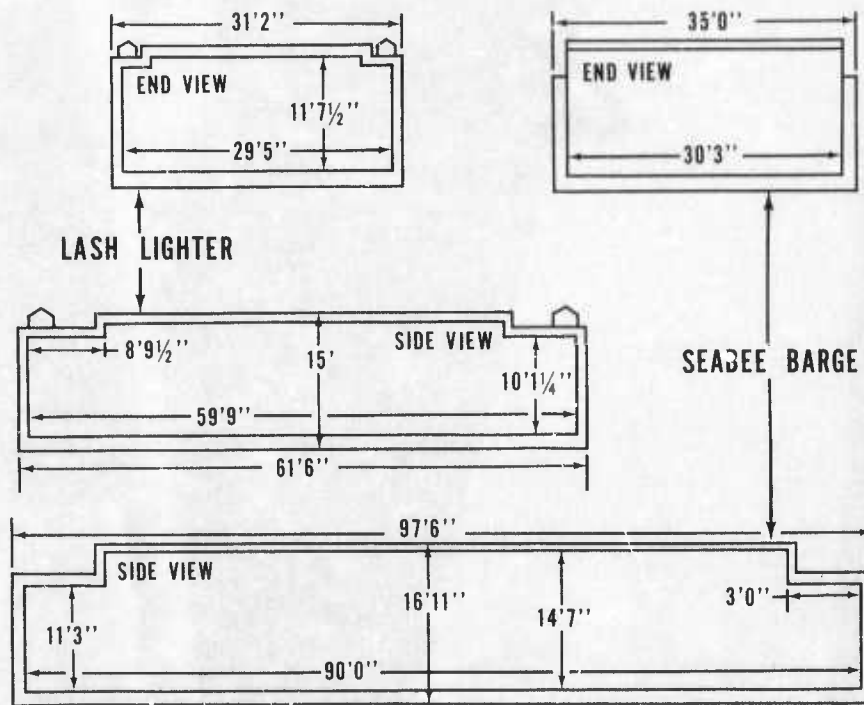

Figure 11. Size Comparison of LASH Lighter to SEABEE Barge.



Figure 12. Overstowed Containers in SEABEE Barge.

3. LASH (Figure 13).

a. There have been 16 US Flag LASH ships built and 4 more are programmed to be in operation by January 1975. There are two types of LASH ships: the first design, the C8, and the later C9 with a larger lighter capacity. Several configurations of each type are in operation, depending on their trade route. In an all-lighter configuration most US flag C8 LASH can carry up to 77 lighters; the C9 LASH up to 89 lighters. Many LASH operators carry mixes of 20- and 40-foot containers with the lighters. A typical C8 example would be 62 lighters and 334 TEU containers. With minor retrofit, the C8 LASH could carry about 1,498 TEU containers as a pure containership.

b. The LASH ships stack their lighters in cells and on top of the hatch covers. This method offers good flexibility for commercial schedules to multiple ports. All LASH ships are equipped with a 500-LTON gantry crane to lift the lighters at the stern of the ship and stow them athwartships throughout the ship (Figures 14 and 15). When appropriate, a 35-LTON gantry crane located forward is used to load containers, also athwartships (Figure 16). Theoretically, a LASH ship can load or discharge its lighters in about 20 hours. The container crane is capable of handling approximately 16-20-foot containers an hour.

c. LASH lighters are relatively thin-skinned, double-hulled boxes with watertight hatch covers (Figure 17). Most are of steel construction but some are made of fiberglass; some are steel with only the hatches fiberglass. The steel inner hull is not watertight, and a hole in the outer hull could result in a flooded cargo compartment. The lighter can carry up to 371 LTON of cargo at a maximum draft of just over 8 feet but most cargo loads of average density draw 5 or 6 feet. Although it is possible to accommodate seven 20-foot containers inside a LASH barge, there is a considerable penalty in unused cargo space and weight-carrying capacity. The majority of lighters are not equipped to be easily ventilated and have no provisions for smoke detection or fire extinguishers. New, second generation lighters aboard C9 LASH just entering service will have these provisions. The lighters are not accessible during transit in the mother ship.

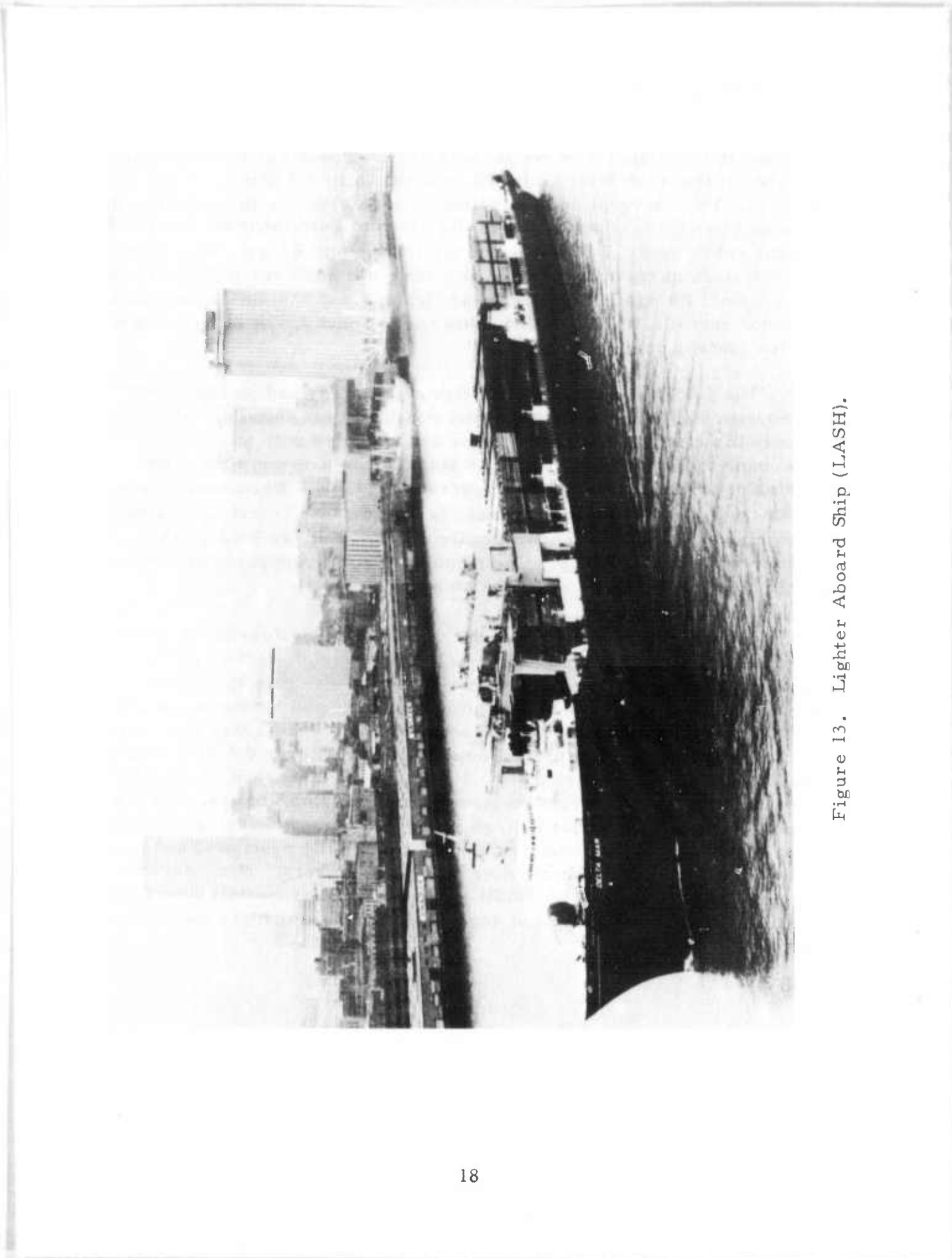

Figure 13. Lighter Aboard Ship (LASH).

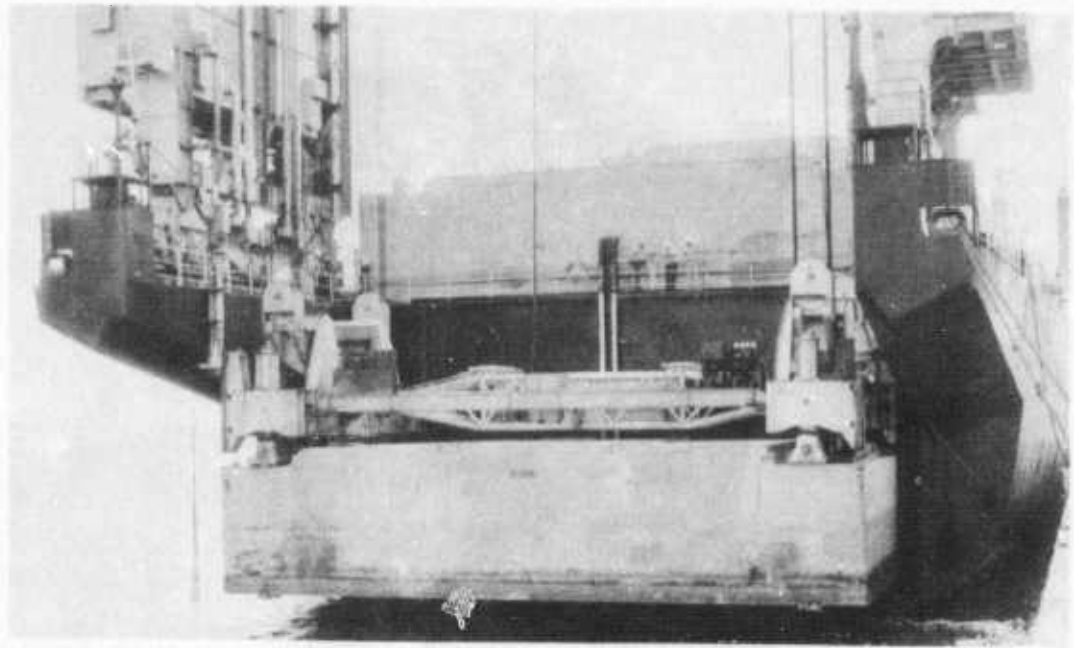

Figure 14. LASH Lighter Being Lifted Aboard.

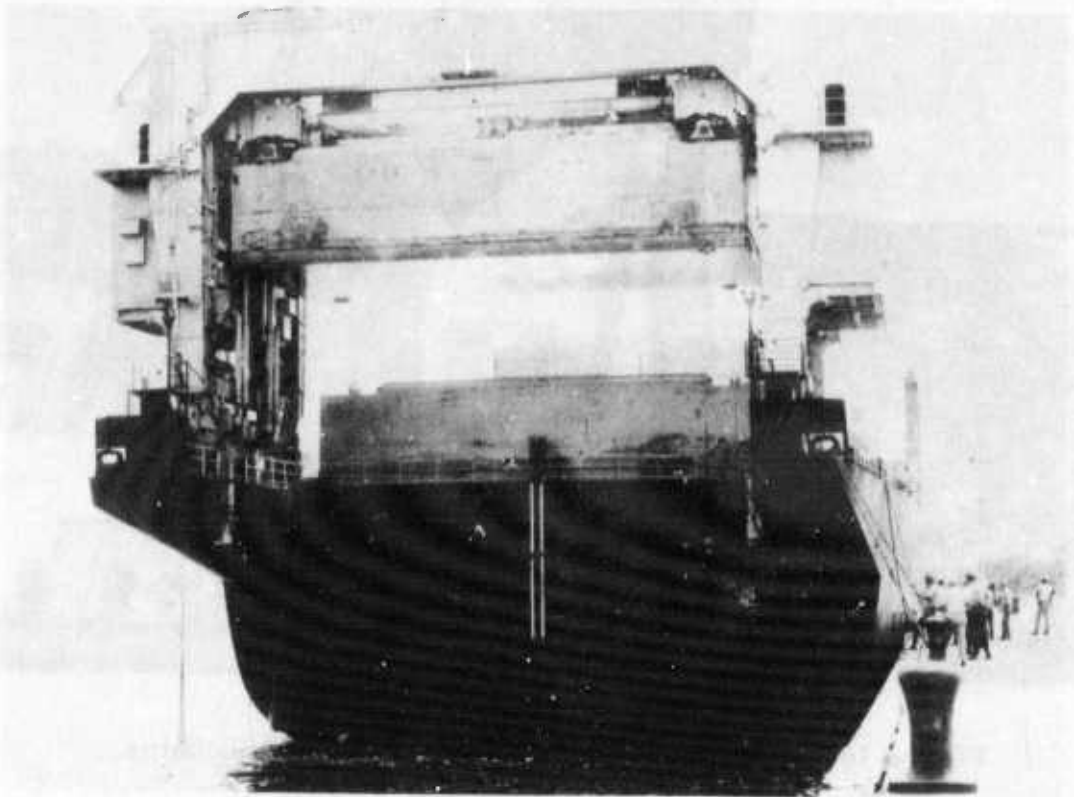

Figure 15. LASH Gantry Crane Stowing Lighter.

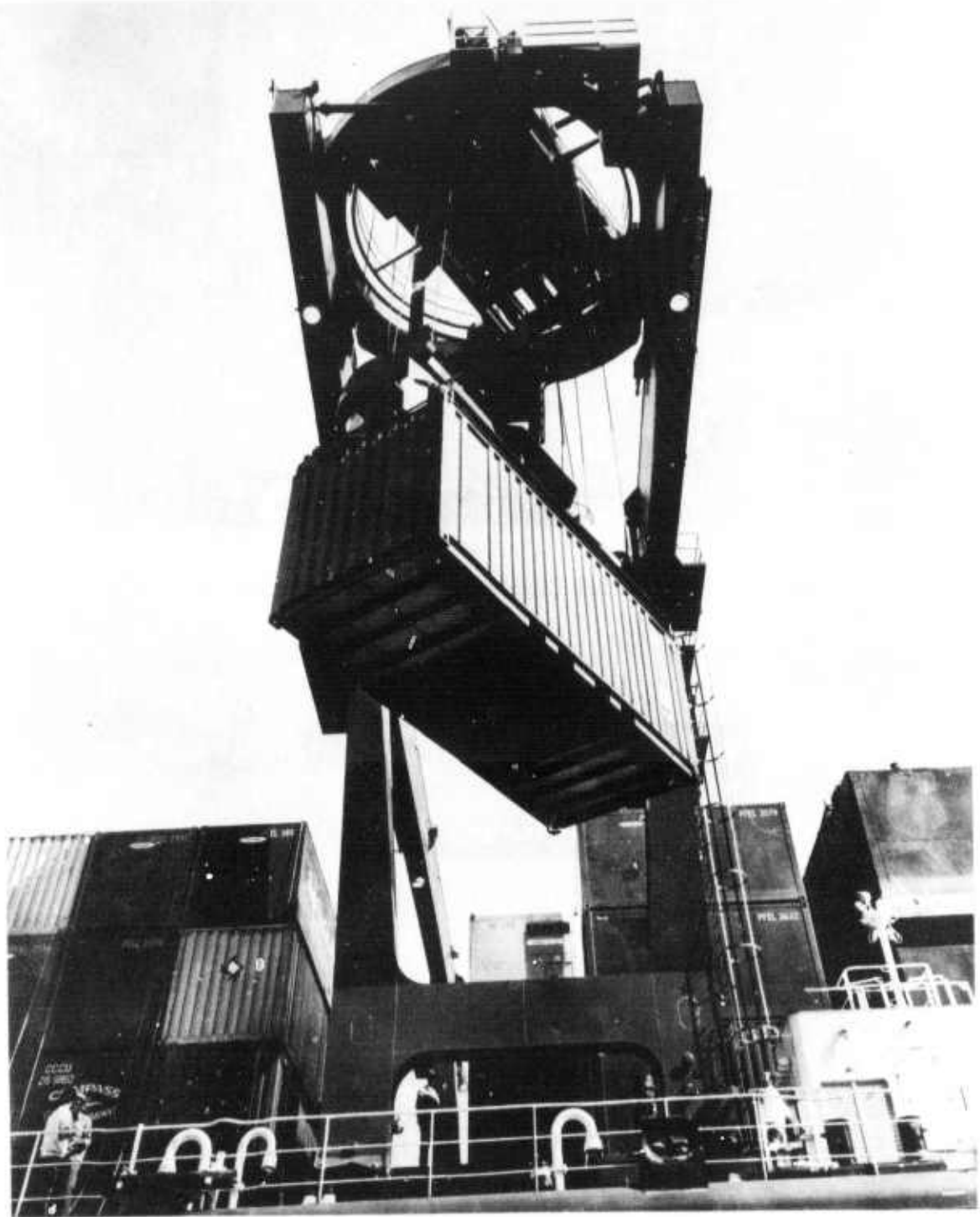
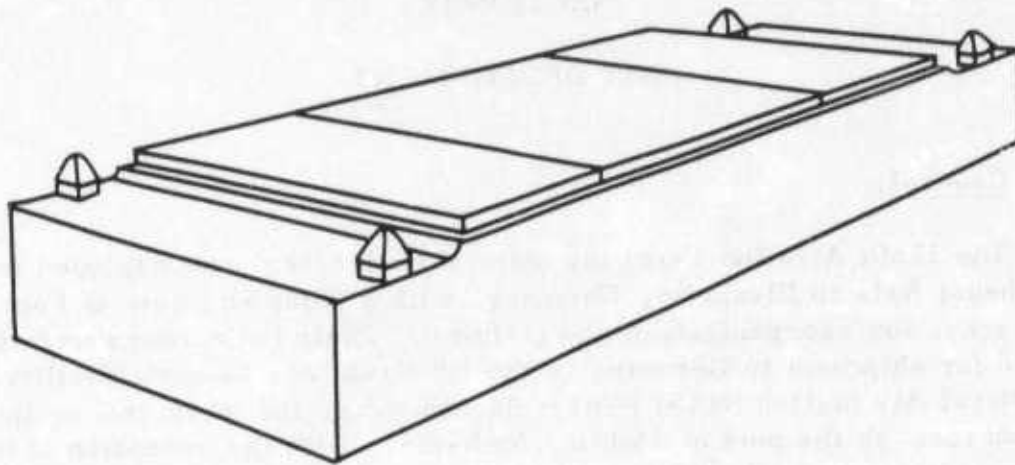

Figure 16. Container Crane Aboard Some LASH Ships.



Hatch Panels:	3 ea, approx 6,000 lb per panel
Cargo Capacity:	371 LTON/19,600 cu ft.
Empty Draft:	2'½"
Fully Loaded Draft:	8'2"
Lighter Empty Weight:	80 LTON

Figure 17. LASH Lighter Characteristics.

SECTION IV

UNIT DEPLOYMENT

1. General.

The 175th Aviation Company (Attack Helicopter) was deployed from Southeast Asia to Illesheim, Germany, with a delay en route at Fort Knox, Kentucky, for reorganization and training. Their helicopters were prepared for shipment to Germany by the US Naval Air Rework Facility at the Naval Air Station (NAS) Pensacola, Florida, and their unit equipment moved through the port of Mobile, Alabama. With the exception of two equipment escorts, the personnel of the company were transported to Germany by airlift.

2. Helicopter Loading.

a. The unit's helicopters consisted of 21 AH-1G Cobras (Figure 18) and 2 UH-1H Hueys, a total of 3,440 MTON but only 90 STON. The only disassembly was the removal of the main and tail rotor blades, and the wing ejector racks. The helicopters were preserved for below-deck shipment in accordance with accepted Army procedures^{10/} at an average cost of \$500 and approximately 75 man-hours per helicopter (Figure 19). Six SEABEE barges were towed from New Orleans and berthed two abreast at the NAS aircraft carrier pier. Loading commenced at 1300 hours on 11 January 1973. A US Navy 60-ton mobile crane with a 70-foot boom was used to remove the hatch covers of each barge. The covers weigh 2.8 tons each (Figure 20). Twenty minutes was required to undo 36 perimeter lug fasteners, undo 24 between-hatch fasteners, and remove and stack the seven hatch covers of the first barge.

b. The first barge uncovered presented a few surprises. It was a specially configured barge that had an inward cant in the lower port side of the bow. It was learned that there are two such barges per ship, which are placed in the lower deck forward and conform to the contour of the ship's hull. Two of these six barges were of this type, one port and one starboard. The canted bow bulkhead did not affect loading or bracing techniques for the helicopters or detract from the integrity of the stow (Figure 21). Although loss of cube resulting from the canted bulkhead was not a significant factor in the helicopter loadings, such loss could

^{10/} TM 1-AH1-S, Preparation for Shipment of AH-1G/TH-1G Helicopters and TM 1-UH1-S, Preparation for Shipment of UH-1 Helicopters.

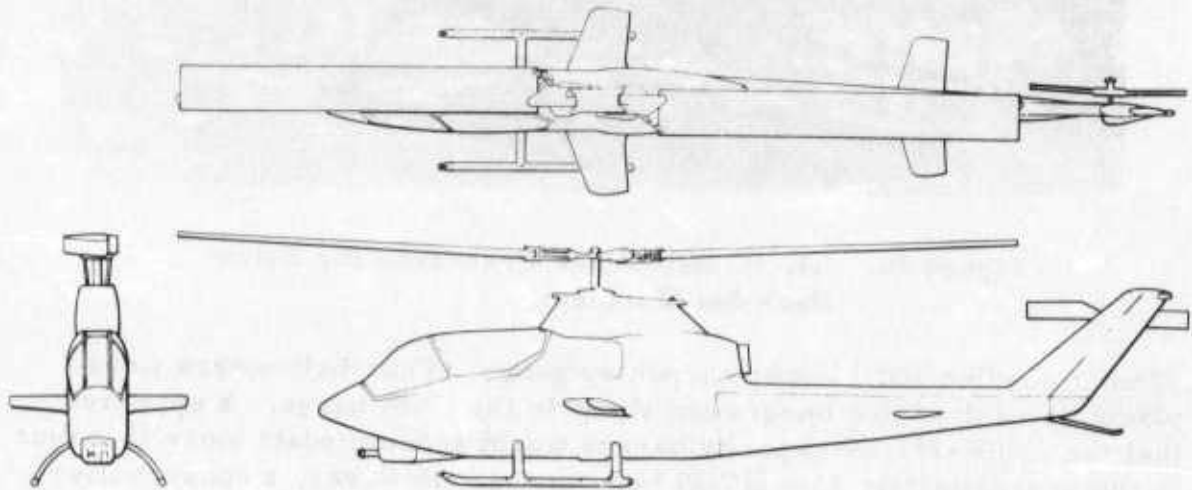

Figure 18. AH-1G Cobra Helicopter.

warrant the specification of the conventional barge for military cargo such as CONEX containers, which are of such size as to permit high cube utilization of the barge. A considerable quantity of water, apparently the result of rainfall admitted through an open hatch, had accumulated in this first barge. Loading commenced in disregard of the water although efforts were made to pump the barge dry. Moisture was still present upon installation and sealing of the hatch covers.

c. The loadings were accomplished under the cognizance of the Commander, Mobile (Alabama) Detachment, MTMC. The stevedore force was composed of a supervisor and foreman from Mobile and locally hired



Figure 19. AH-1G Helicopter Preserved for Below Deck Sea Shipment.

17-man loading and 11-man carpentry gangs. Four helicopters were placed in each of five barges and three in the sixth barge. It appeared that the 1,000-MTON-capacity barges would accommodate more than four of the approximately 150-MTON helicopters. However, a conservative approach for this initial helicopter loading proved to be appropriate. The local SEABEE agent had denied an MTMC request to install temporary deck tiedown fittings. Therefore, only side and end bulkhead fittings were available.

d. Prior to placement of the first helicopter, random-width dunnage of 1-inch stock was laid on the deck in a process similar to strip decking. Decking was laid only under the skid tubes, extending from port to starboard bulkheads. It was not possible to nail or secure the decking to the steel surface of the barge, hence, the loading would be classified as "floating"; that is, not rigidly fixed and free to yield to a limited extent upon subjection to external forces. Lumber of 4- by 6-inch stock was placed in contact with each side bulkhead directly over the decking and secured thereto. Each helicopter was lowered into its final fore-and-aft stowage location; fine adjustments in position were made by means of

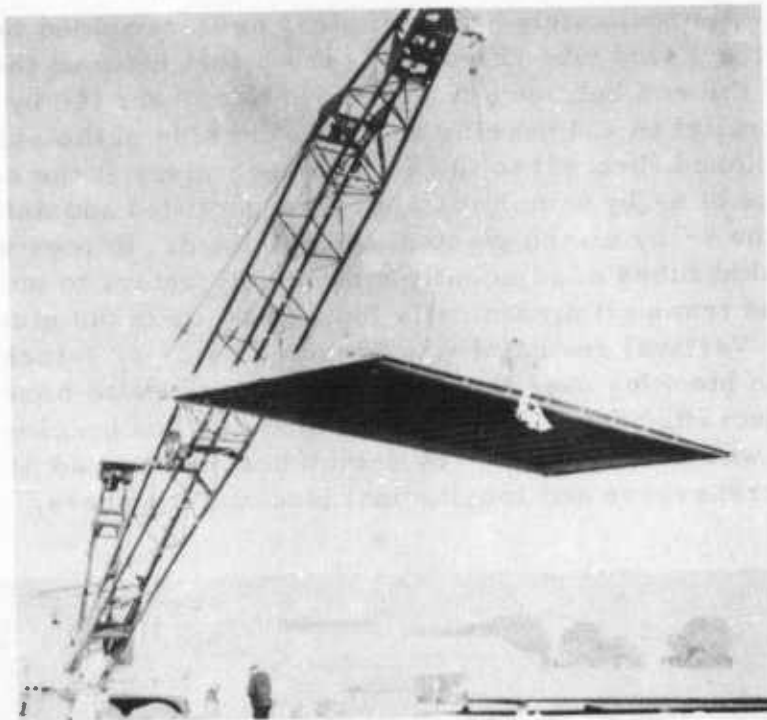

Figure 20. Mobile Crane Removing SEABEE Barge Hatch Cover.

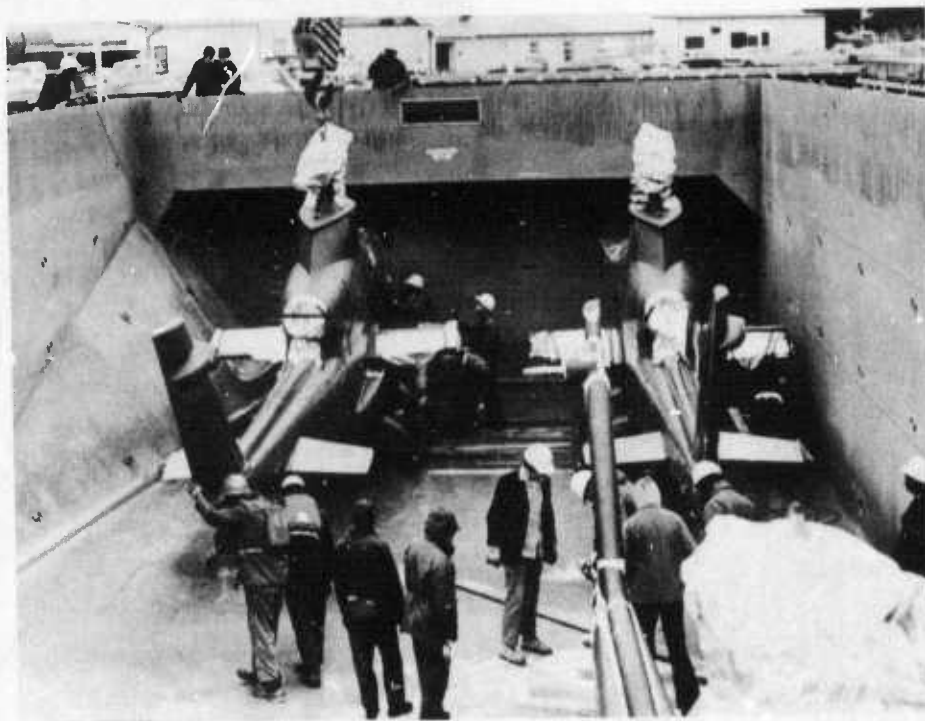

Figure 21. Loading AH-1G Cobras Aboard SEABEE Barge With Modified Bow.

guide ropes. Approximately 4 feet of clear area remained between the side bulkhead and skid tube (Figure 22) and 8 feet between the front of the skid tube and the end bulkhead (Figure 23). Members (4- by 6-inch) were positioned parallel to and bearing against each side of the skid tubes. These were kicked (braced) to the 4- by 6-inch piece at the adjacent bulkhead by means of 4- by 6-inch members wedge-fitted and nailed to the decking and the 4- by 6-inch piece at the bulkhead. Braces were extended between the skid tubes of adjacently stowed helicopters to unitize the stow effectively and transmit dynamically induced loads to the side bulkheads (Figure 24). Vertical restraint was provided by 2- by 4-inch members secured to the blocking over the skid tubes and extended beneath the fuselage of the aircraft. Stabilization of the blocking and bracing structure, as required, was provided by 2- by 4-inch braces secured at angles to intersecting transverse and longitudinal blocking members.

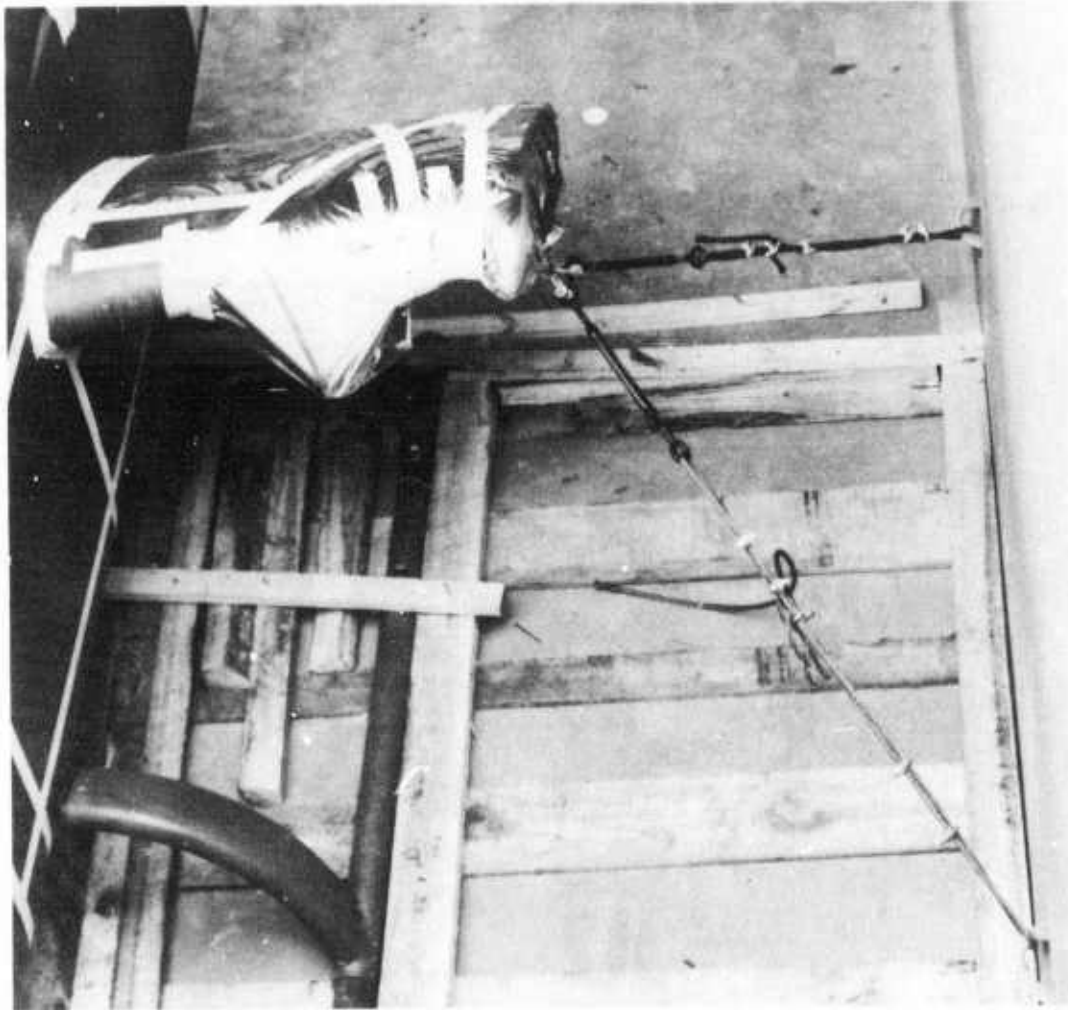

Figure 22. AH-1G Helicopter Tiedowns to SEABEE Barge Side Bulkhead Fittings.

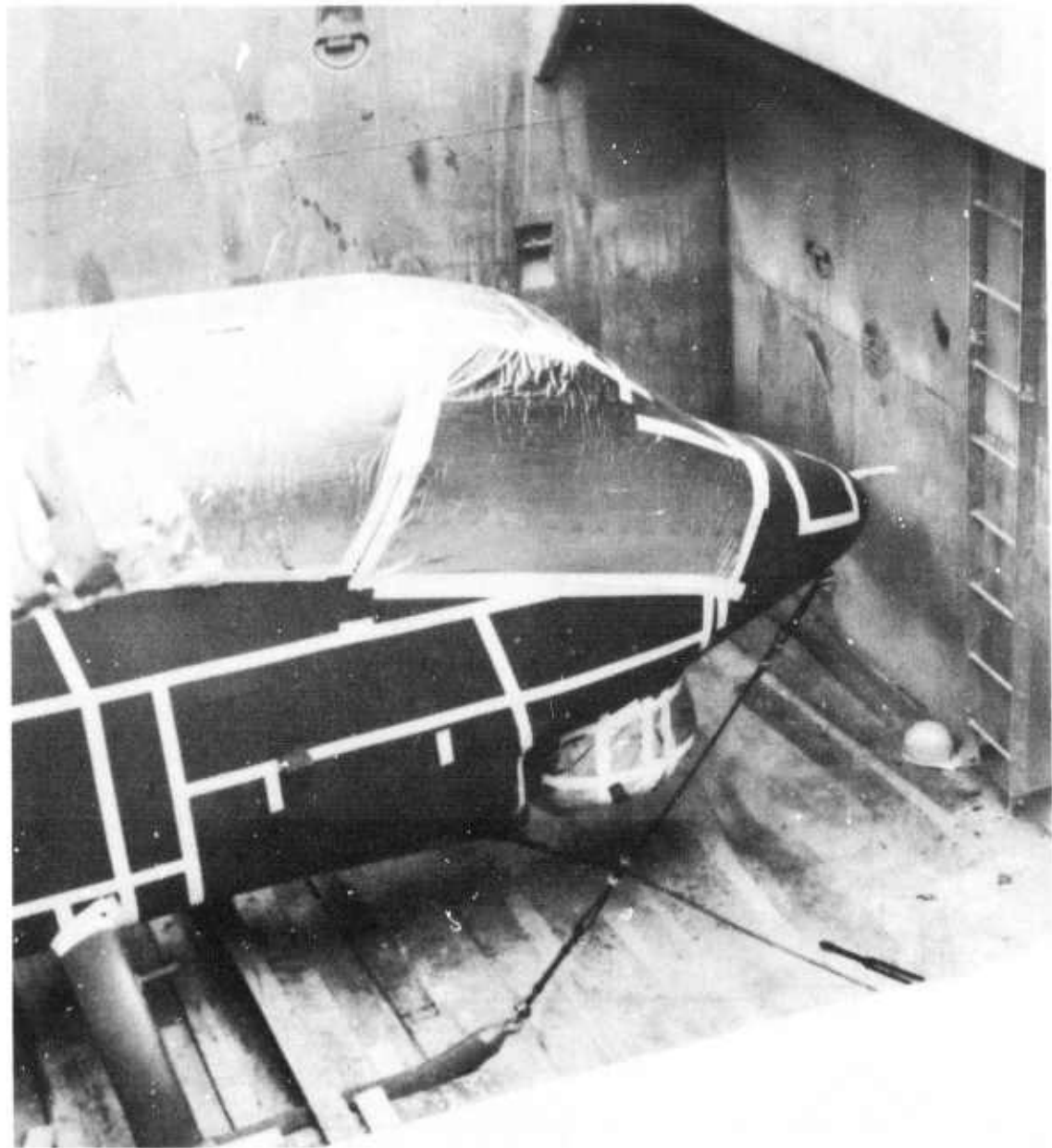

Figure 23. AH-1G Helicopter Tiedowns to SEABEE Barge Forward Bulkhead Fittings.

e. Helicopters were lashed using standard 5/8-inch wire rope, clips, and eye and eye end pull turnbuckles. There are four designated tiedown points on the AH-1G Cobra. They are jack/tiedown fittings that are installed during processing; two under the fuselage, fore and aft, and one under each wing (Figure 25). These fittings are only rated for 500 pounds of tension. The skid landing gears are not designated for tiedown because they are not structural members and are only attached to the

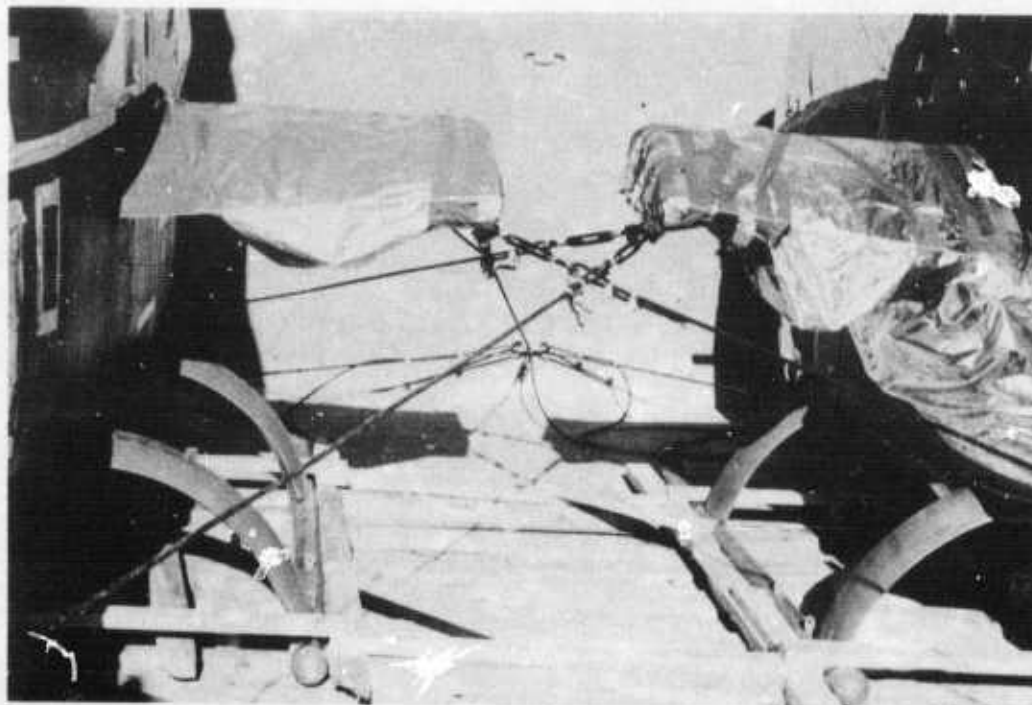

Figure 24. Braces Unitize Stow of AH-1G Helicopters in SEABEE Barge.

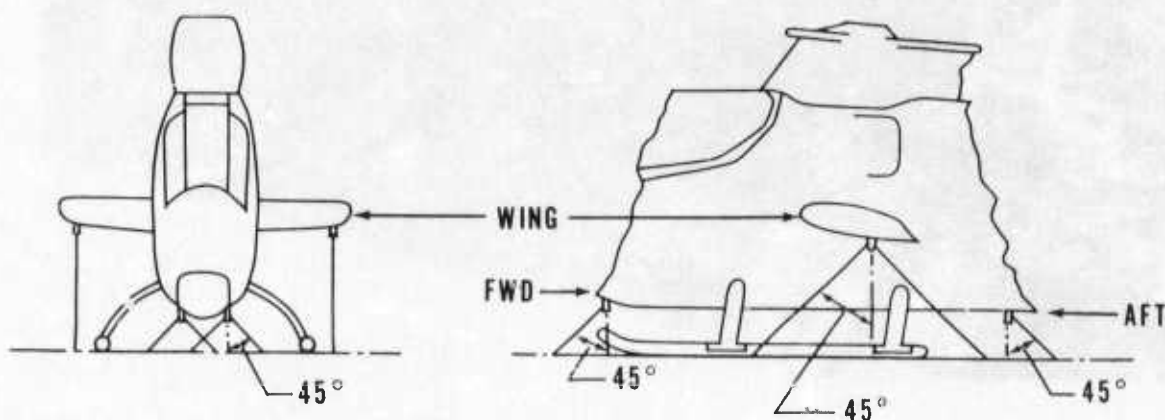

Figure 25. AH-1G Helicopter Jack/Tiedown Fittings.

fuselage by a few U-bolts. However, the stevedores elected to use the towing ring on the forward end of the skids for lashing and ignored the forward fuselage fitting (see Figure 23). This procedure was permitted by the representative from the US Army Aviation Systems Command after he examined the entire tiedown pattern. An attempt was made to lash the helicopters in such a manner as to maintain desired plan and floor angles of 30 degrees. However, the location of tiedown fixtures on the helicopters

and the nonavailability of deck tiedowns required excessively long cable runs and lashing angles considerably less than optimum, particularly in providing vertical restraint (Figure 26). The long lengths of cable, necessitated by the need to lash to adjacent bulkheads, precluded the stowage of more than four helicopters per barge and in some cases came close to interfering with other helicopters at the fragile skin surfaces. Padding material was affixed to the skin at such points of possible interference (Figure 27). Cable tension, a significant factor in aircraft restraint, was adequately checked for excess by the deflection method and no potentially damaging cable tension was observed in the loadings.

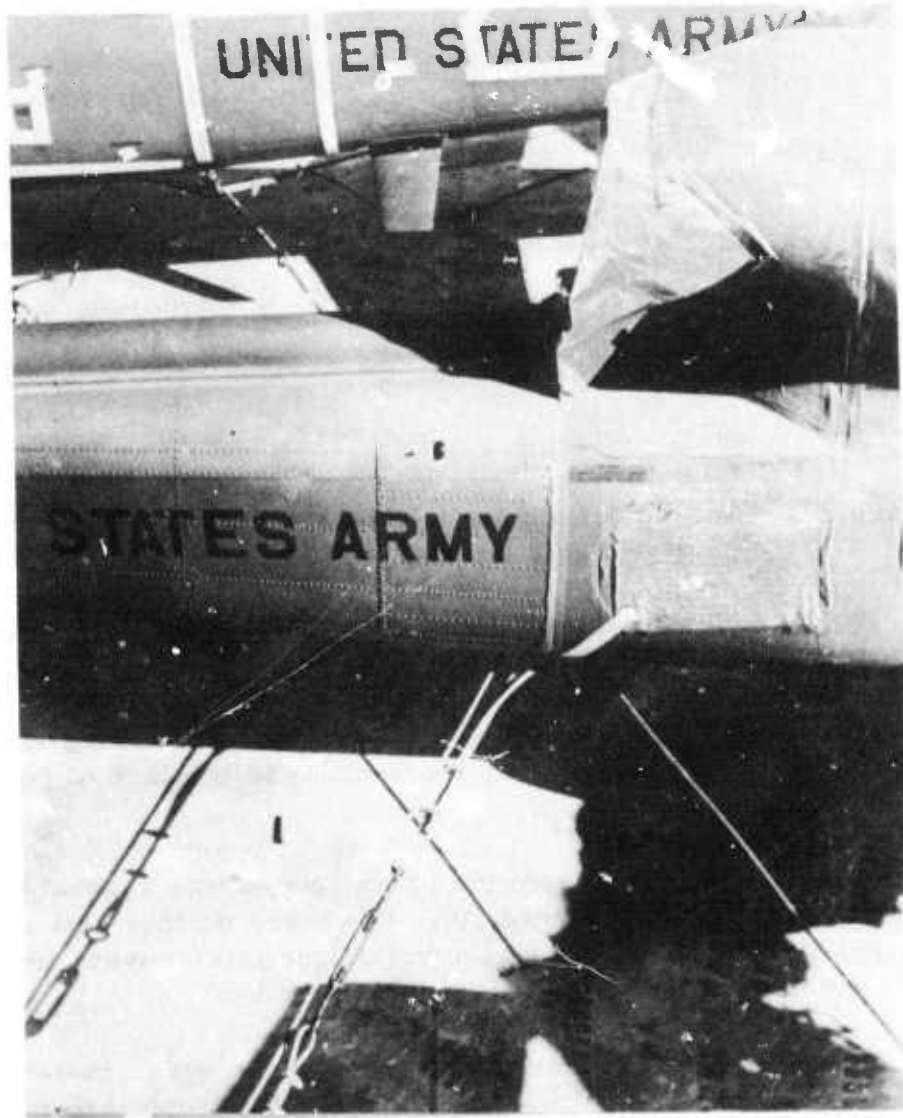

Figure 26. Lack of Deck Tiedown Fittings Required Long Cable Runs to SEABEE Barge Side Bulkhead Fittings.

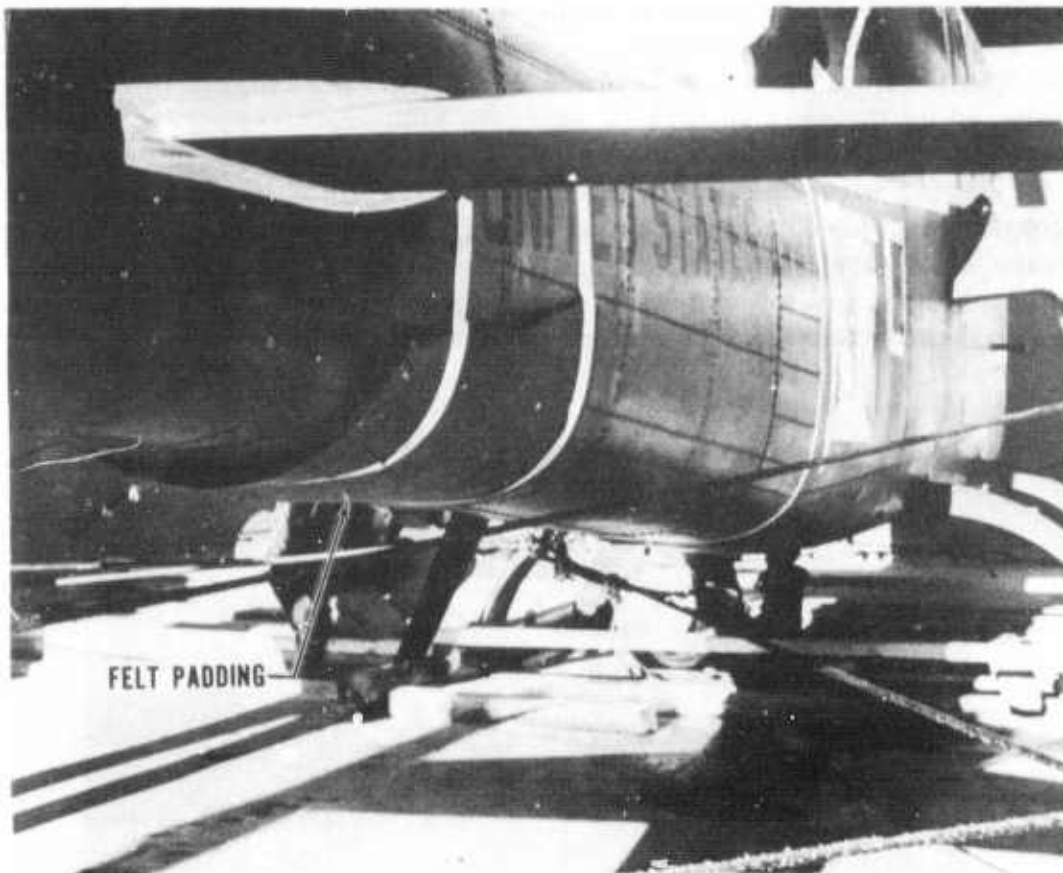

Figure 27. Padding Affixed to Helicopters To Protect Against Possible Cable Interference.

f. The four jack/tiedown points on the UH-1H Huey helicopter are under the fuselage and rated for 1,000 pounds tension vertically and 500 pounds laterally and aft. The stevedores used all four designated fittings (Figure 28), but they again lashed to the skid-mounted towing rings. The aft tiedown cable angles were very shallow due to the lack of deck tiedown fittings (Figure 29).

g. Vertical clearance from the hatch covers was adequate for both the UH-1H and the AH-1G (Figure 30). However, neither helicopter could fit in the smaller LASH lighters with watertight hatch covers installed unless the rotor head and the mast were removed.

h. The boxed rotor blades were stored in the barge containing only three AH-1G Cobras. Again the long runs of cable would preclude the stowage of additional helicopters (Figure 31).

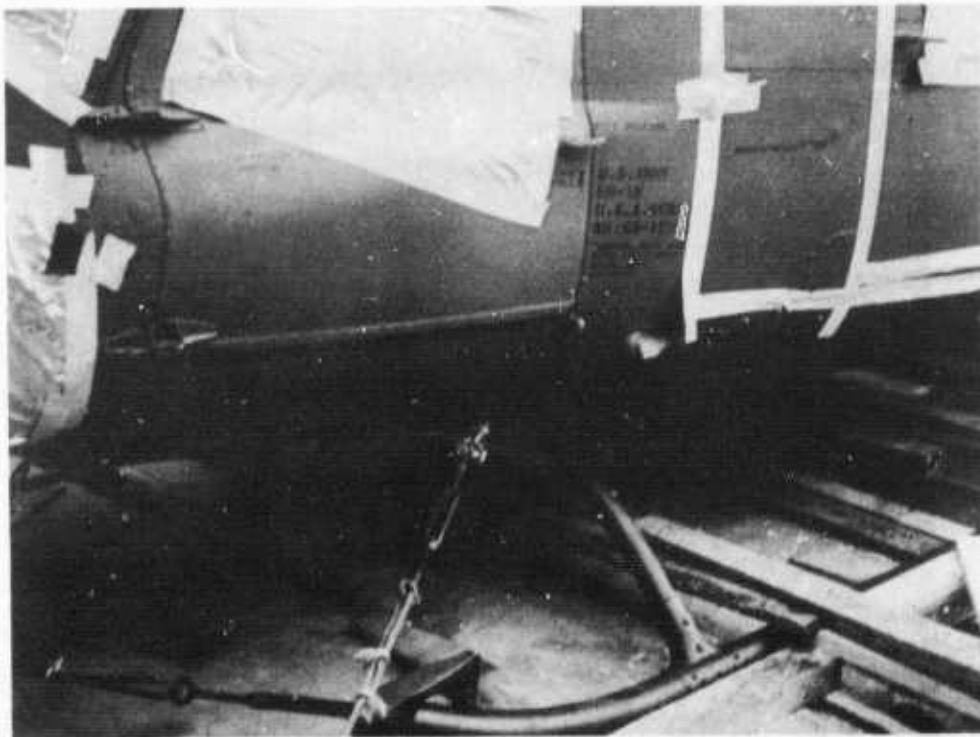

Figure 28. UH-1H Huey Helicopter Forward Jack/Tiedown Fitting.

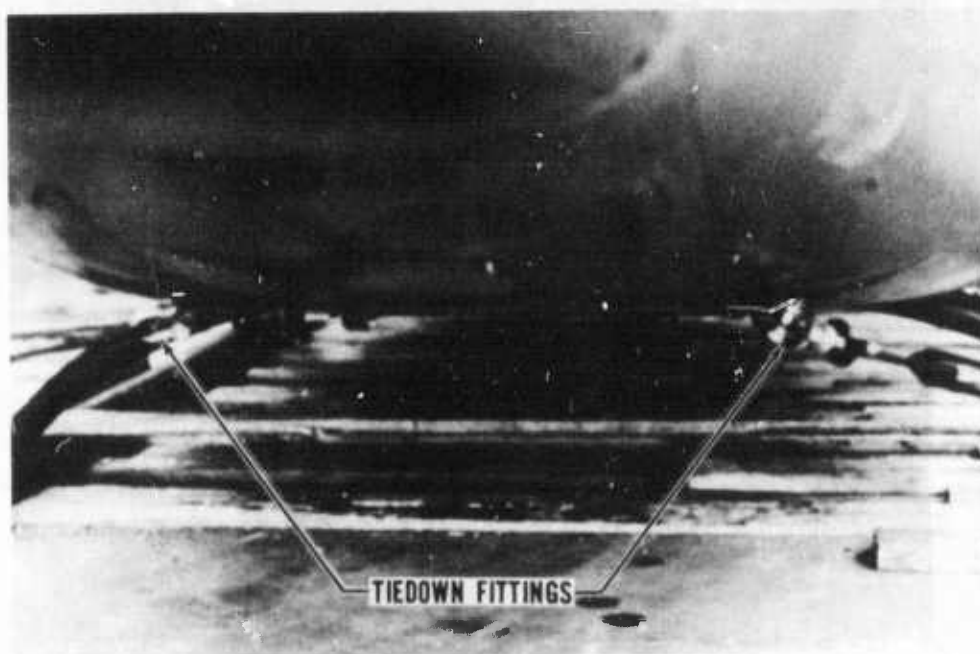

Figure 29. UH-1H Huey Helicopter Aft Jack/Tiedown Fittings.

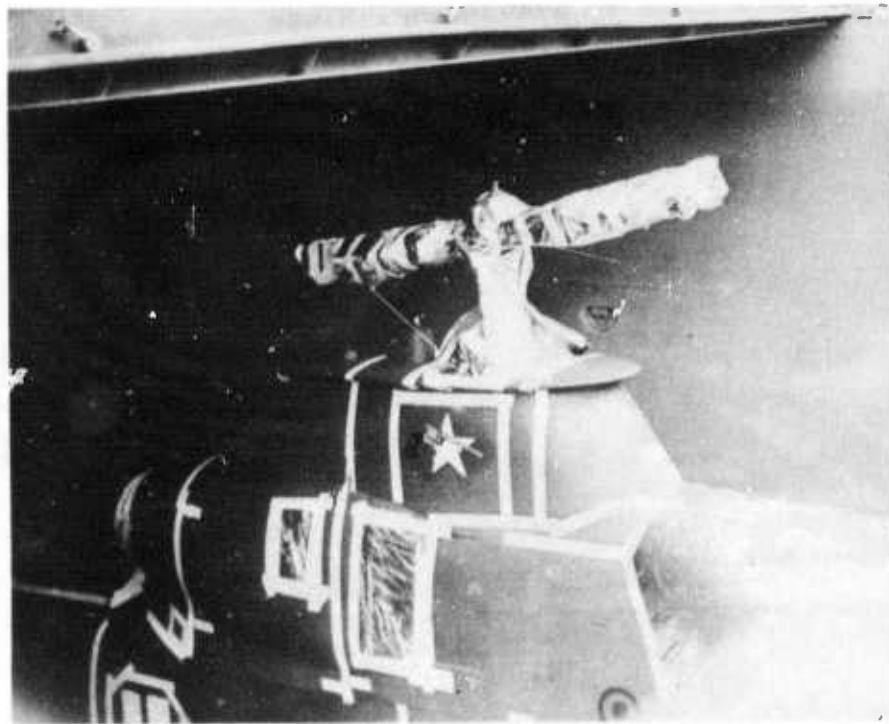
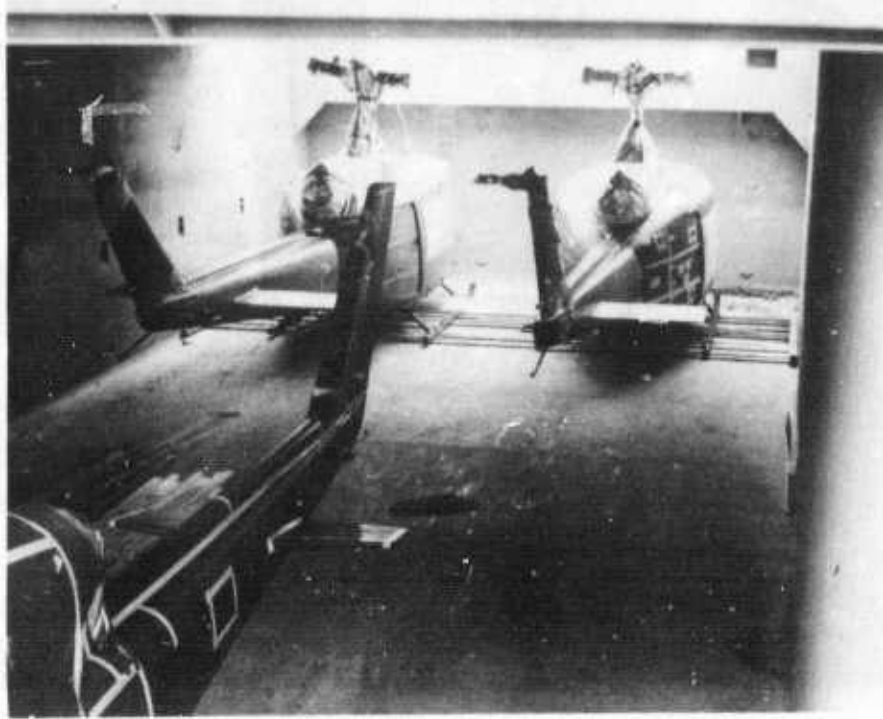

Figure 30. Helicopter Vertical Clearance From SEABEE Barge Hatch Covers.

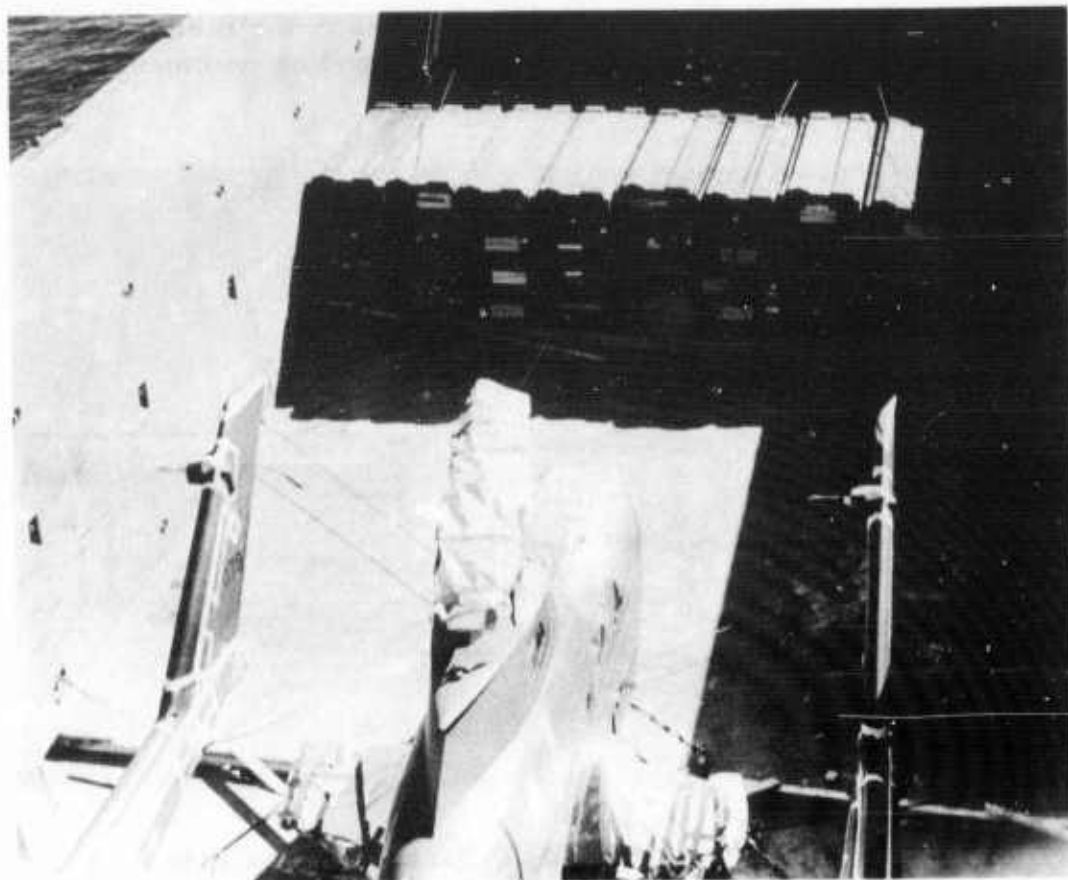

Figure 31. Rotor Blade Containers Stowed in SEABEE Barge.

i. Two barges were loaded with eight helicopters during the 4 afternoon hours of the first day. The next day the third barge was loaded and the empty barges were rotated to dockside by a US Navy tugboat. The remaining helicopters and rotor blade containers were loaded and most of the lashing and bracing completed. The temperature was in the low 20's and a brisk wind was blowing across the pier, making working conditions very uncomfortable. Final tiedowns were completed and barge hatch covers replaced by noon the third day. The total loading time of 16 hours was not excessive for this initial experience sans deck tiedown fittings and the attendant large amount of lashing required. The barges were towed to Mobile in 15 hours on 14 January 1973.

3. Unit Equipment Loading.

a. In early January 1973, the unit equipment of the 175th Aviation Company (AM) was shipped from Fort Knox to the port of Mobile on 27 railcars. It consisted of 62 assorted vehicles and 127 pieces of military impedimenta totaling 1,891 MTON, or 396 STON. Four SEABEE barges

were towed from New Orleans and berthed at the Army pier in Mobile (Figure 32). Since 15 January was a holiday, loading commenced at 0800 hours on 16 January.



Figure 32. Berthing SEABEE Barge at Army Pier in Mobile, Alabama.

b. The heaviest equipment was loaded first and positioned in the corners of the barge. The first vehicle loaded was a 3-ton forklift truck (Figure 33). This vehicle had not been decubed properly by the unit in accordance with current regulations and guidance.^{11/} If the tines of the fork had been removed and stowed properly, it would have saved the Army the cost of 7.4 MTON, which, in this case, amounted to \$218.30. This is a common shortcoming with shippers who are oriented primarily to CONUS line-haul considerations. Proper decubing and use of vehicle cargo bodies to ship equipment by the free cargo (FREECAR) concept would result in significant cost savings. The unit did make maximum use of its vehicles for FREECAR loading, but elected to cover the cargo with costly lumber rather than organic tarpaulins.

^{11/} AR 220-10, Preparation for Overseas Movement and TB 55-46-1/2, Standard Characteristics for Transportability of Military Vehicles and Other Outsize/Overweight Equipment.

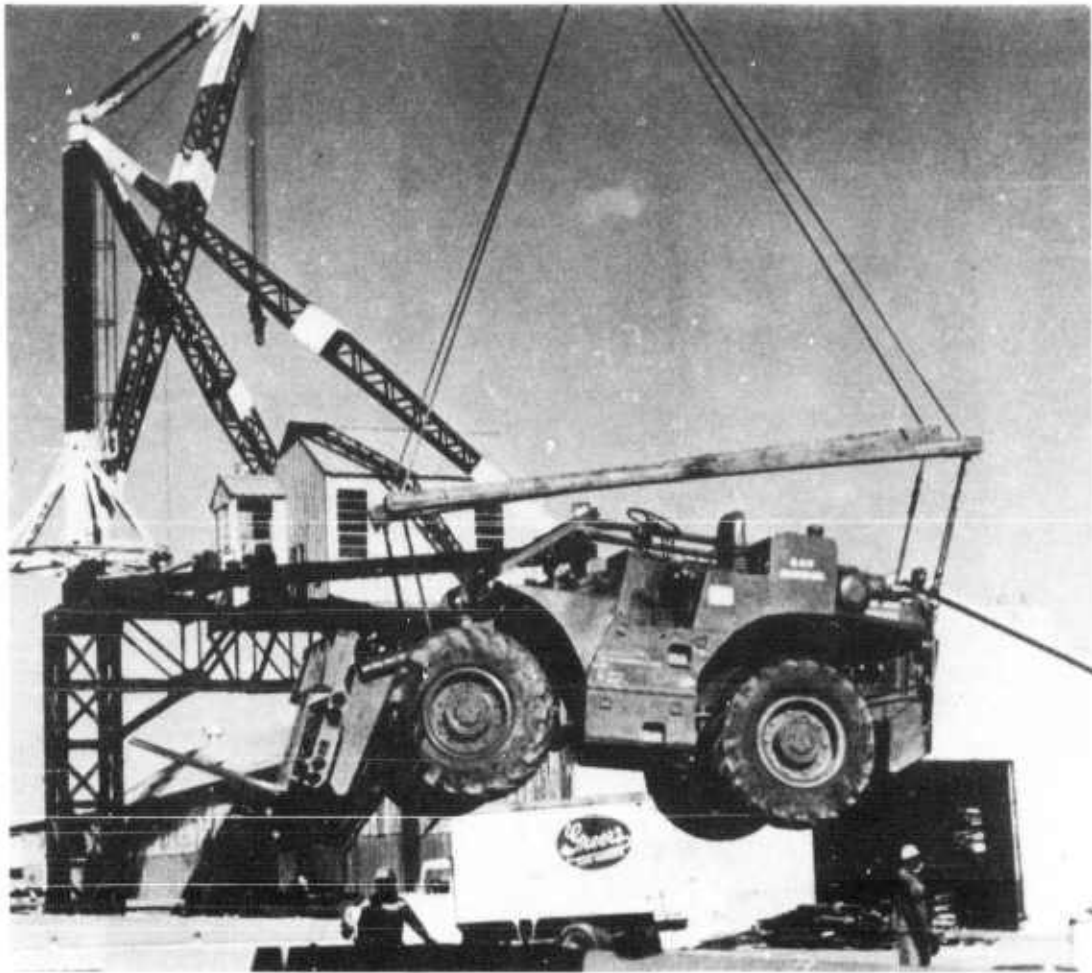

Figure 33. Improperly Decubed Forklift Truck Being Loaded Aboard SEABEE Barge.

c. Within 2 hours, including 20 minutes for hatch cover removal but not finished vehicle securement, the following 11 vehicles were loaded into the first barge (Figure 34):

- 2 5-ton avionics vans.
- 1 2-1/2-ton fire truck.
- 1 5-ton wrecker.
- 4 5-ton cargo trucks.
- 1 6,000-pound forklift truck.
- 2 1-1/2-ton trailers with tanks.

d. Preload dunnaging required for wheeled vehicles was minimal. Lumber, 4- by 4- or 4- by 6-inch, was positioned at the intersection of the side bulkheads and deck to serve as spacers and prevent contact of the

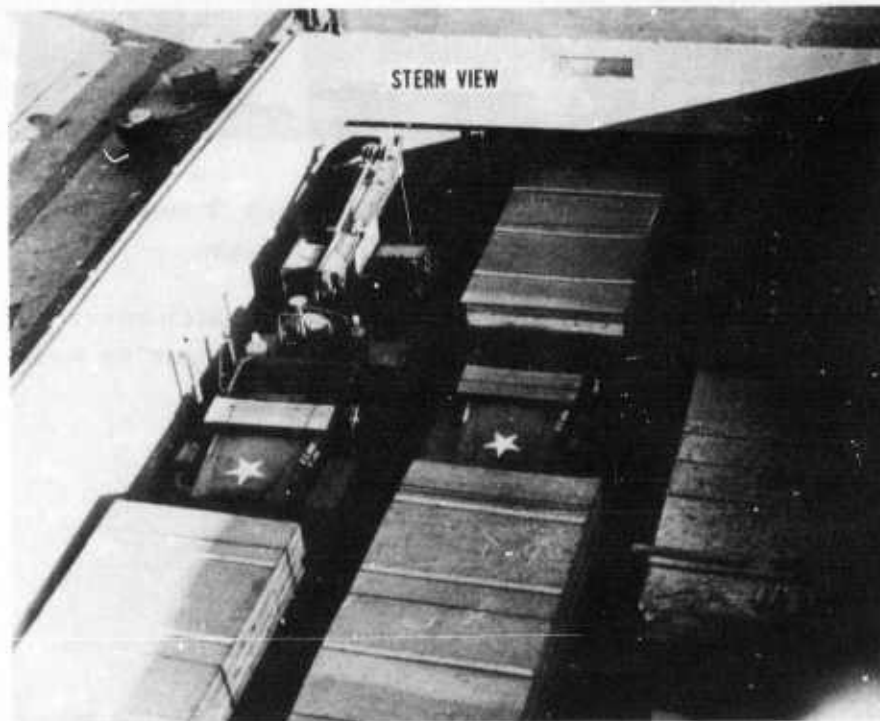
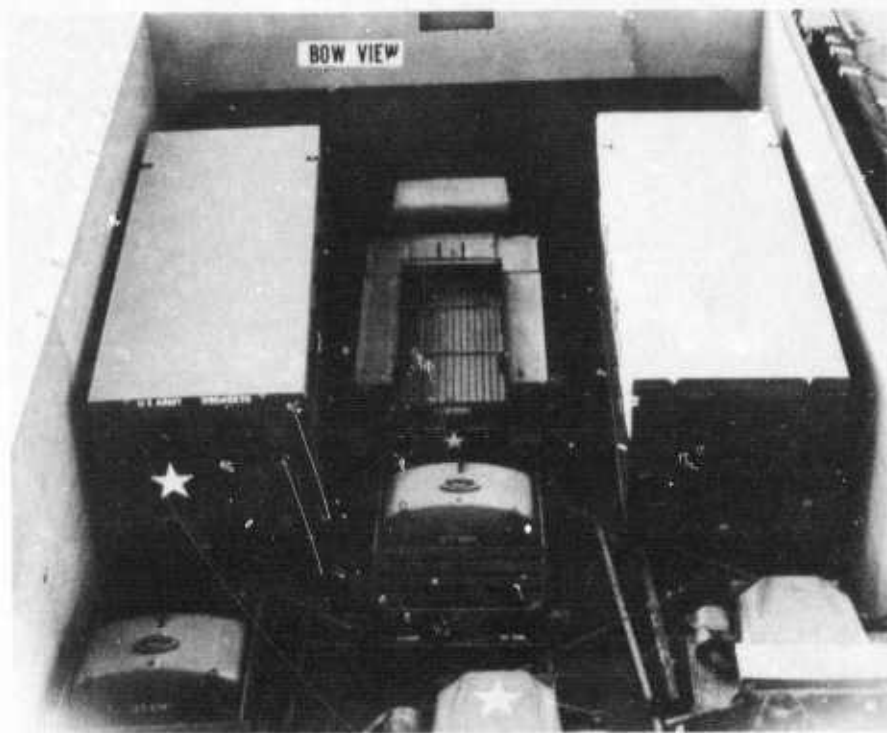

Figure 34. Stowage of 11 Military Vehicles in SEABEE Barge.

vehicle with the bulkhead. Vehicles were lowered directly into the final fore-and-aft-stowage position with the tires bearing directly against the bulkhead dunnage. A minimum of free area was provided between the end of the vehicle and the end bulkhead to facilitate lashing and blocking installation (Figure 35). Loading proceeded by diagonally opposed quarter decks, with the interior portion of the barge being loaded lastly.

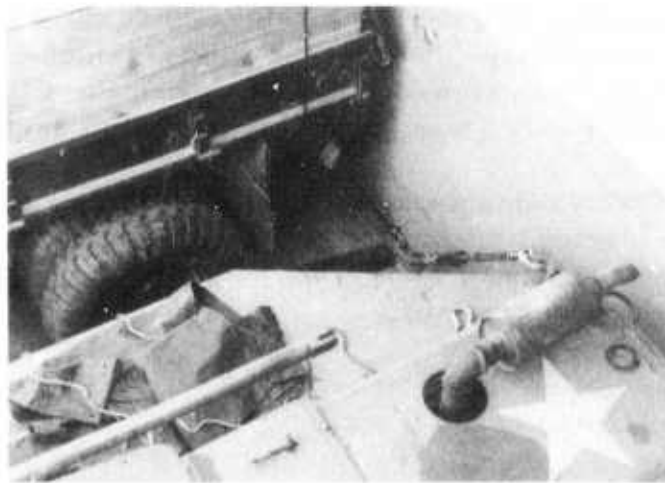

Figure 35. Views of Vehicle Lashings to SEABEE Barge End Bulkhead Fittings.

e. The blocking, bracing, and lashing procedures employed equalled or exceeded those specified^{12/} for wheeled vehicle stowage below deck. Dunnage utilized was of 4- by 4-inch minimum stock; vehicles were lashed by means of 5/8-inch wire rope and clips, 3/4-inch shackles and class four, 3/4-inch eye and eye turnbuckles having a clear opening between heads of 24 inches.

f. Blocking was installed parallel to the vehicle and bore directly against the tires. Transverse members were secured on both sides of the wheel for the single-axle vehicles and at the front and rear wheels of tandem bogeys (Figure 36). This chocking member prevented fore-and-aft motion of the vehicle; it was installed over the side wheel blocking and was securely fastened thereto, thus effectively boxing in the wheels. Blocking was braced to the side and end barge bulkheads with kickers of equal size lumber. The load was unitized in the athwartship direction by bracing the blocking structures around the wheels of each vehicle to that of the adjacently stowed vehicle. The resulting stow was tightly unitized with a minimum of void space, thus reducing the potential for shifting of the cargo.

g. Vehicles were lashed both to each other (Figure 37) and to the bulkheads, thus providing further unitization of the stow. Four lashings were provided per vehicle, and ran to the lowest bulkhead tiedown fitting (padeye) or adjacent vehicle fitting. This resulted in cable lashing plan and floor angle approximating the desired 30 degrees. Only the lowest level of SEABEE padeyes was used, since proper floor angles could not be achieved using the fittings on the middle level. There was no requirement for utilization of the uppermost level of lashing padeyes.

h. Concurrently with vehicle loading, 30 CONEX containers were loaded into the fourth barge and covered with 3/4-inch plywood. Vehicles and equipment were then stowed over and around the CONEX containers. The following mixed cargo was loaded in this fourth barge (Figure 38):

- 30 CONEX containers.
- 4 1-1/2-ton ammunition trailers.
- 6 3/4-ton trucks.
- 8 1-1/2-ton trailers.
- 2 1/4-ton trailers.
- 2 600-gallon water tanks.
- 1 2-1/2-ton cargo truck.

^{12/} EAMTMTS Reg 55-36, Lashing, Securing, and Chocking of Wheeled Vehicles and Other Cargoes Stowed in MSC Procured Vessels, 2 February 1972, with Change 1, December 1973.

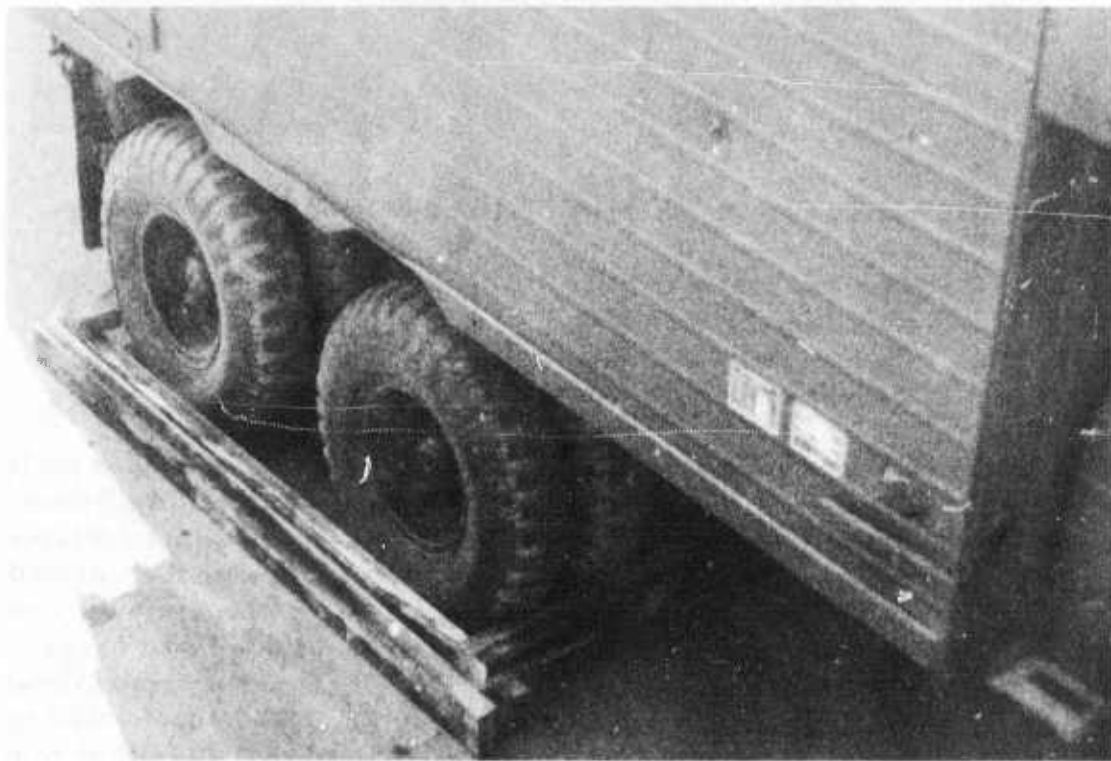
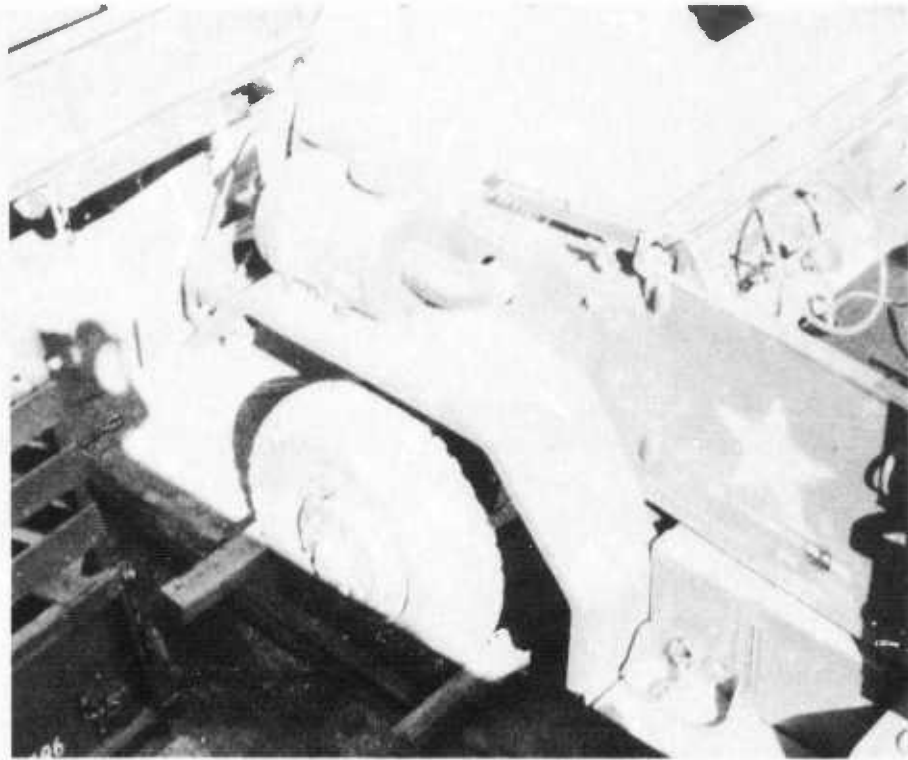

Figure 36. Views of Vehicle Wheel Blocking in SEABEE Barge.

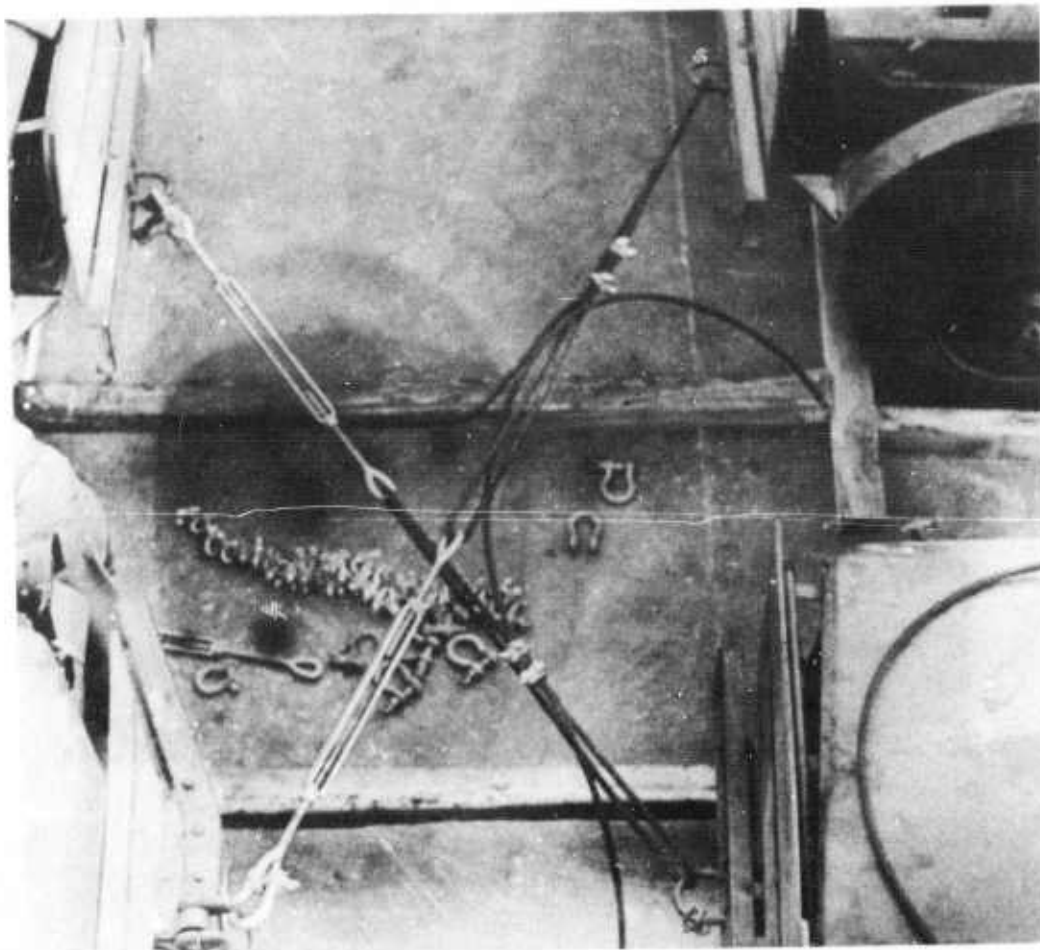

Figure 37. Intervehicle Lashings Unitized Stow in SEABEE Barge.

- 2 1/4-ton utility trucks.
- 1 auxiliary light trailer.
- 2 transporter dollies.
- 2 XM-18 machine gun pods.

i. When it was first learned that only 4 barges had been made available for the 27 railcars of equipment, the Commander, Mobile Detachment, was doubtful that they would suffice and reserved some containers for possible use for any excess equipment. However, with the outstanding cube utilization of these spacious barges there was no need for the containers. There was an abundance of unused space in the third barge, which contained low profile 1-1/4-ton trucks. If required, approximately 50 percent more of that barge could have been loaded by second decking with integral pedestal mounts and flat racks. The 1,891 MTON of equipment loaded in four barges equated to an average of 473 MTON per barge,

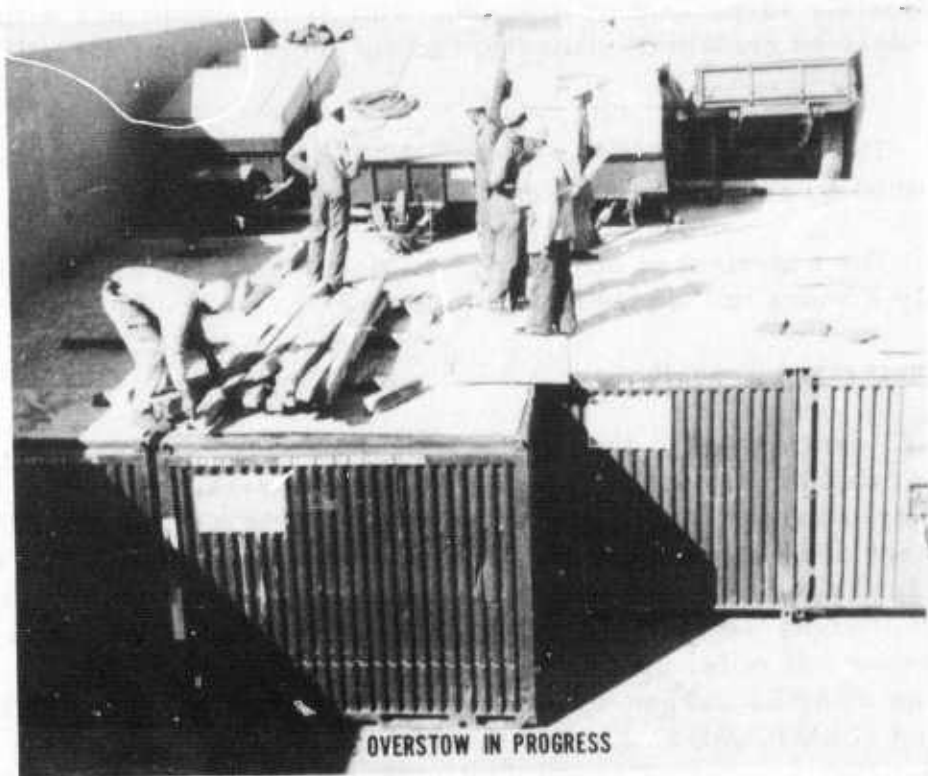

Figure 38. Overstow of High-Density Military Cargo
in SEABEE Barge.

approximately 48-percent utilization. This is in consonance with the MTMC-derived container-utilization factor of 50 percent for unit equipment.

j. The secure CONEX container was stowed in a decktop container as required by current regulations.

k. The experienced stevedores at Mobile using two mobile cranes took only 8 hours to load these four barges.

4. Intertheater Transit.

On 23 January 1973, the original SEABEE ship, Doctor Lykes, made its initial call to the port of Mobile, Alabama, to take on waiting loaded barges including the 10 barges containing 5,331 MTON (487 STON) of helicopters and equipment of the 175th Aviation Company (AH). The Doctor Lykes arrived in Rotterdam, Holland, on 7 February 1973 (Figure 39). The barges were discharged (Figure 40), made up into tows, and moved some 200 miles upstream to Mannheim, Germany (Figure 41). The large SEABEE barges were moved without incident. The US European Command (USEUCOM) has tested the SEABEE barges extensively. They found that they are very maneuverable, that tug operators are able to handle them without much difficulty, and they melded right in with other river traffic (Figure 42).^{13/}



Figure 39. SEABEE Ship Docking at Rotterdam, Holland.

^{13/} US European Command Briefing, "SEABEE Operations on the Rhine River," Second Barge Transportation Appraisal Program (BARTAP) Conference, Headquarters, Military Sealift Command, 16 October 1973.

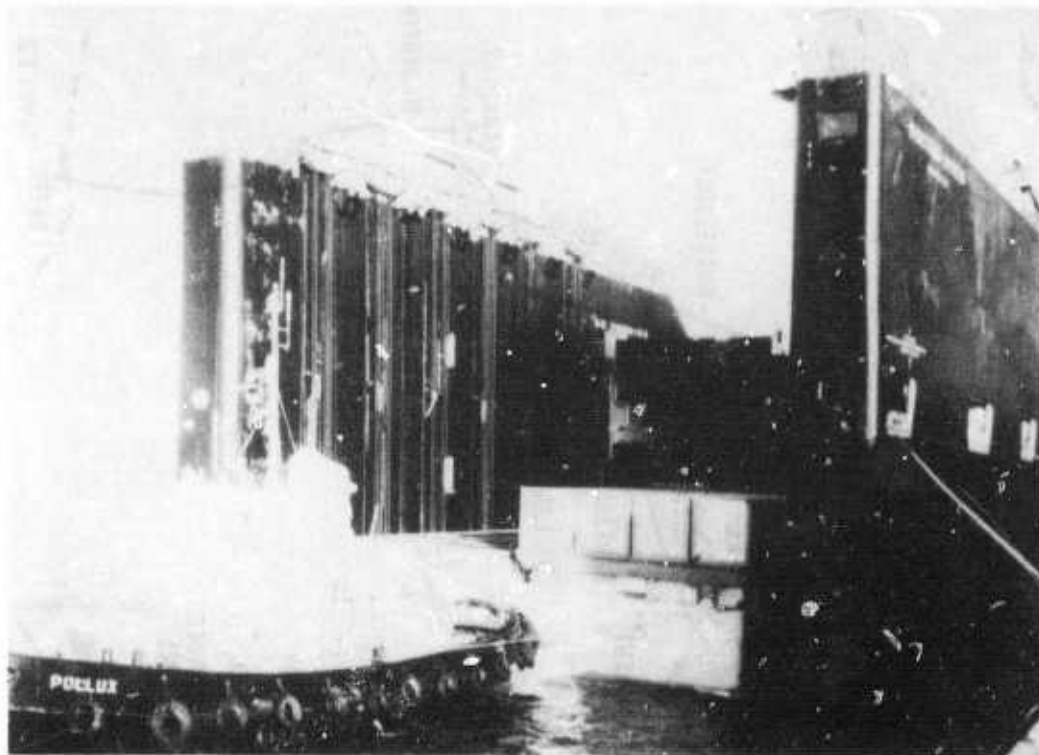

Figure 40. Dutch Tugboats Discharge SEABEE Barges.

5. Destination Handling.

a. The port complex of Mannheim has 40 cargo handling sites. The US Army Rhine River Terminal has responsibility for the handling of Government cargo, normally through civilian contractors. The first barges arrived at Mannheim on 12 February and were spotted at Rhenus-Rheinau, a commercial contractor whose discharge area is located just south of Mannheim. This site was selected because it was adjacent to a large storage area and a tracked gantry crane, which could be moved clear for helicopter operations. Rail sidings parallel the quay where cargo can be unloaded directly onto railcars for faster port clearance.

b. As the 10 barges were opened it was apparent that the move had been completed with no damage. This was significant because another helicopter company move completed 3 months prior by a Seatrain vessel had 10 helicopters damaged by salt water. Ten sets of landing skids and three main rotor hubs were replaced at a cost of \$44,014.^{14/} There

^{14/} US Army Europe (USAREUR) Briefing, "Unit Move Via SEABEE", Second Barge Transportation Appraisal Program (BARTAP) Conference, Headquarters, Military Sealift Command, 16 October 1973.

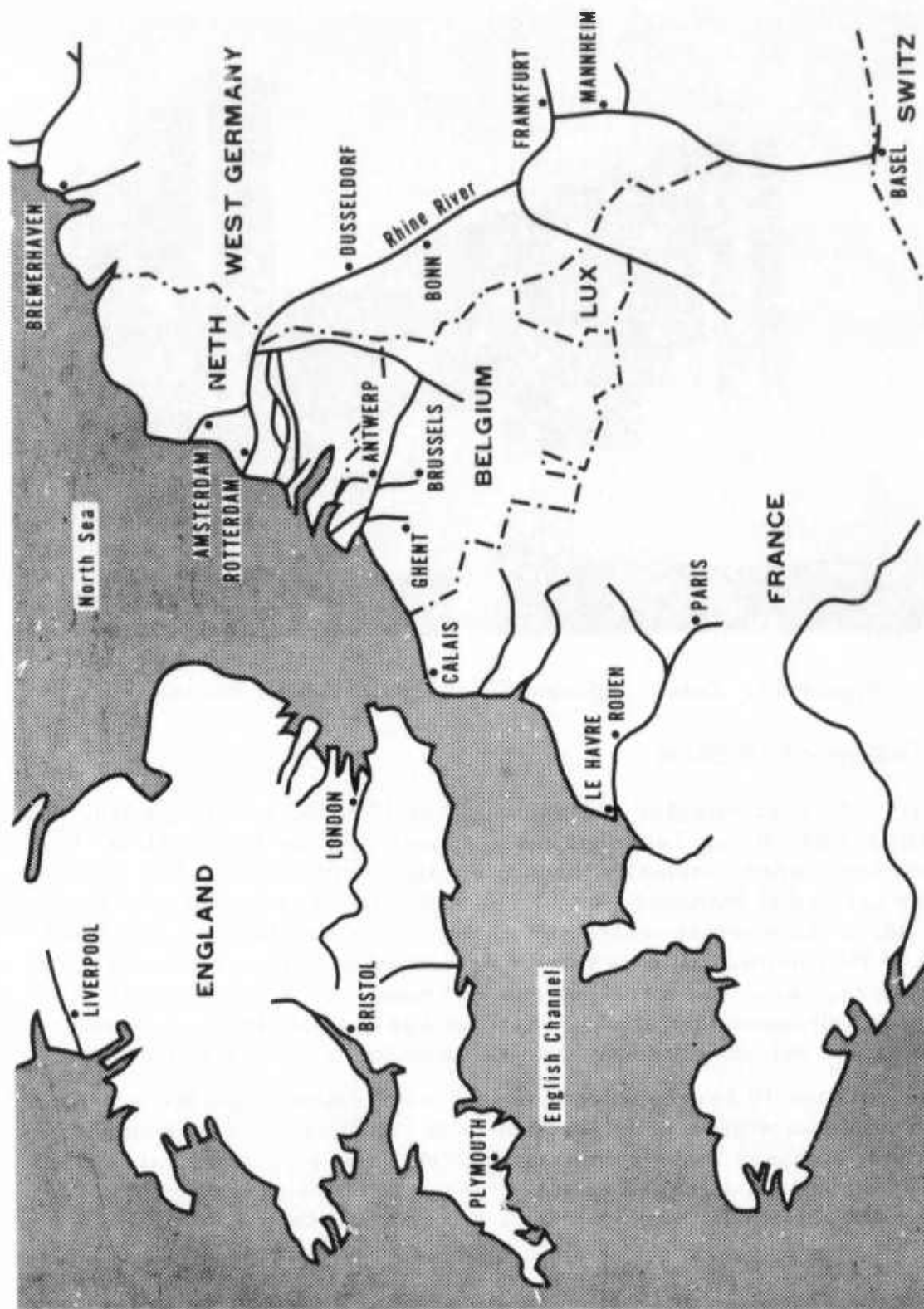

Figure 41. Rhine River System.

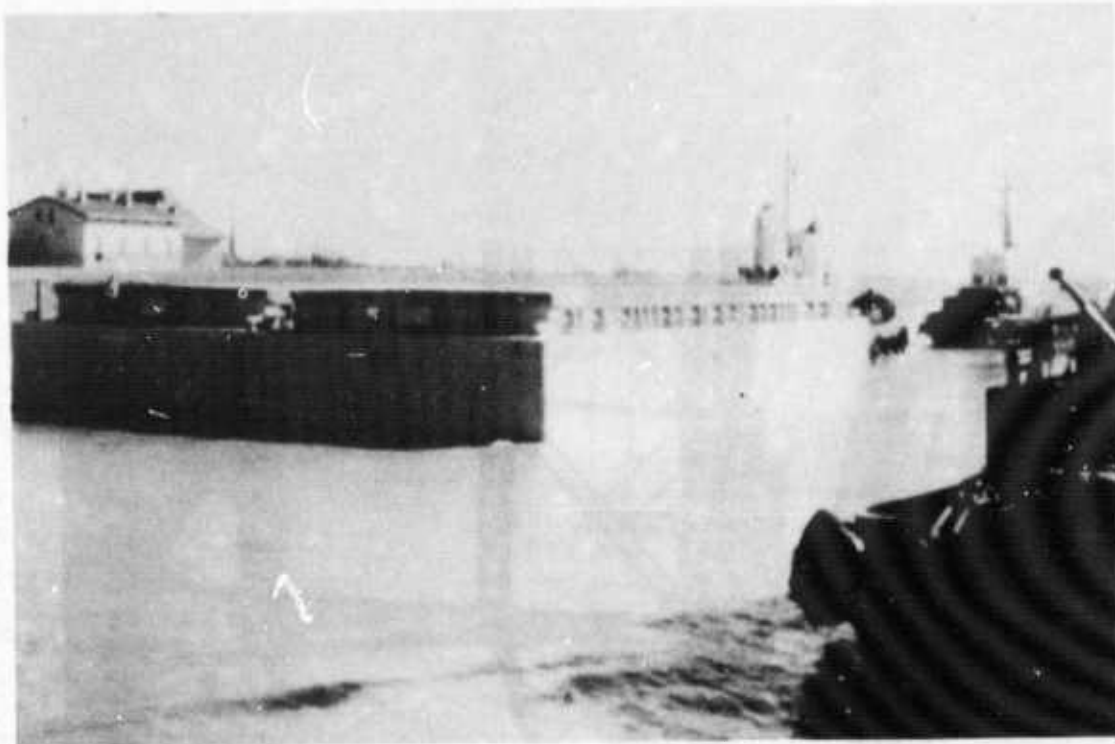

Figure 42. SEABEE Barges Transiting Rhine River.

was no water in the SEABEE barges. Unloading commenced at 0715 hours on 13 February and was completed by 1630 hours on 14 February. The barges were worked as they arrived from Rotterdam. Total off-loading time was 13 hours and 25 minutes, which was 56 percent of the total loading time of 24 hours at Pensacola and Mobile.

c. Port clearance was effected as follows:

- (1) A total of 60 vehicles and 57 pieces of impedimenta went to Illesheim by rail.
- (2) Two vehicles departed for Illesheim by unit driveaway.
- (3) The rotor blade containers were moved to Coleman Barracks, Mannheim, by truck.
- (4) The helicopters were externally airlifted by CH-54A Sky Cranes to Coleman Barracks for deprocessing and preparation for flight.

d. The large gantry crane carried the helicopter (Figure 43) over the railroad tracks to the storage area about 100 yards from the dock. Ground handling wheels were installed and the helicopters towed to an

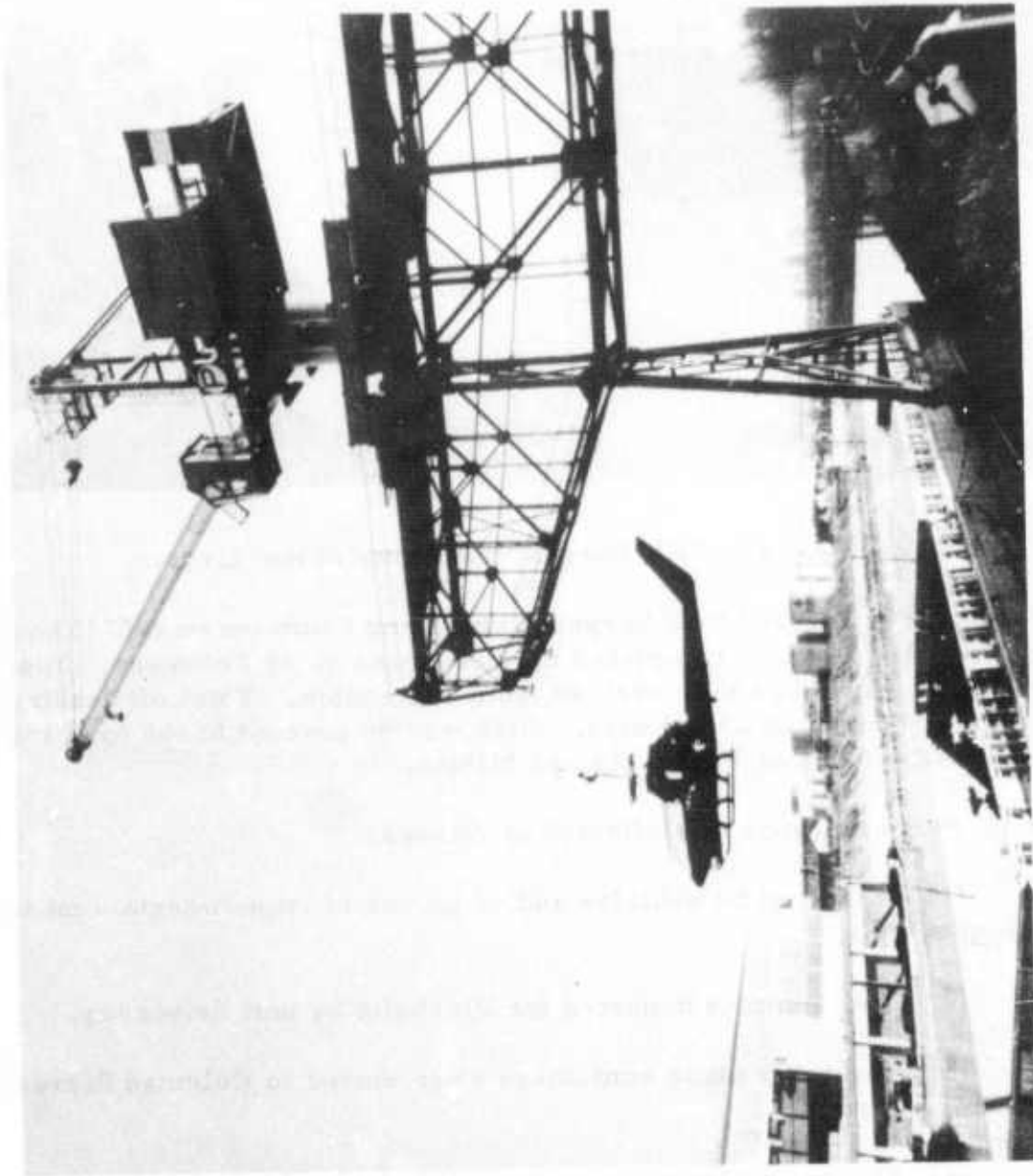

Figure 43. Helicopter Unloading at US Army Rhine River Terminal.

open area to be rigged for the airlift. The flights from Rheinau to Coleman Barracks averaged 20 minutes. Total delivery time was 7 hours and 40 minutes. The Sky Crane operation (Figure 44) was considered a local exercise and its cost was absorbed by training funds normally expended for pilots and crew members of CH-54A helicopters. The helicopters could have been processed at Rheinau or transported by truck to Coleman Barracks, the least desirable mode. The airlift was more expeditious. It took an average of 40 man-hours at a cost of \$359 to prepare each helicopter for flight, which was about 52 percent of the time required and 72 percent of the cost required for oversea processing at NAS Pensacola. The elapsed time to have a helicopter ready for flight test was 3 hours. The helicopters were subsequently flown to Illesheim, approximately 80 miles east of Mannheim, a short local flight.



Figure 44. CH-54A Sky Crane Helicopter Transporting AH-1G Cobra.

e. The only damage sustained was a bent pitot tube (\$200) (caused during the CH-54A airlift) as compared to approximately \$44,000 damage to another unit a few months previously. This large figure represented 10 sets of skids and 3 main rotor hubs that had to be replaced due to salt water damage.

6. US European Command (USEUCOM) Comments.

a. The comments from Europe, both official and unofficial, were highly complimentary of this test move by the SEABEE system. After observing the barge unloadings at Rheinau, the J4, USEUCOM, sent a message to the Commander, MSC. He said, "I feel that the SEABEE concept offers significant potential for both peacetime and contingency users here in Europe, and heartily encourage expanded usage."

b. The following are quotes from a message the Commander, US Army Transportation Command, Europe, sent to MTMC:

(1) "No moisture was noted, either condensation or seawater.

(2) "The dunnage and lashing gear used for securing the helicopters were found adequate. No noted damage was found.

(3) "Cargo was in excellent condition.

(4) "There were no problems encountered."

c. Informal comments emphasized certain advantages of this move:

(1) Rapid availability of equipment after discharge.

(2) Road haul of helicopters was not required at any time.

(3) Added protection from damage.

(4) Improved unit integrity and increased security.

SECTION V

DEPLOYMENT ANALYSIS

1. General.

a. This initial move of a US Army unit by the SEABEE system was an unqualified success and indicates that the barge-ship systems, both SEABEE and LASH, would be highly desirable for future unit moves. However, it was obvious that improvements could be made to the responsiveness, efficiency, and economy of such future moves.

b. It was noted that the helicopters were preserved for below deck storage in hangar workshops in proximity to the loading pier at NAS Pensacola. Then these costly preserved helicopters were put into watertight barges.

c. Only four helicopters were loaded per barge due to the lack of deck tiedown fittings (Figure 45). At the time of this shipment, the Government was billed by the measurement tons (MTON) shipped. Rates now in effect (February 1975) provide for payment of 600 MTON minimum per barge. In any event, the increased efficiency in cube utilization with proper tiedown fittings would be paramount in a contingency situation where these barge-ships would be in great demand.

d. The SEABEE system offers inland river origin port to destination port service under one through bill of lading and minimizes inter-modal transfers. This move used line-haul from origin to an ocean port and required modal transfers.

2. Helicopter Preservation.

a. Investigation revealed that civilian helicopter operators were flying US surplus helicopters directly to the docks at the port of Hamburg, Germany, and shipping them to Galveston, Texas, in SEABEE barges with no disassembly or preservation. All that was done with the CH-34 helicopters was to fold the rotor blades and tail pylons, disconnect the battery, and purge the fuel system (Figure 46). At Galveston, the helicopters were unloaded from the barges onto an open dock, checked for damage and refueled. Within hours the helicopters were flown right from the docks to San Antonio, Texas, (Figure 47). To date, 20 helicopters have been transported by SEABEE with no problems encountered. These operators were highly pleased with the moves and stated that there was no need to protect the helicopters for the relatively short transit time in the watertight SEABEE barges.

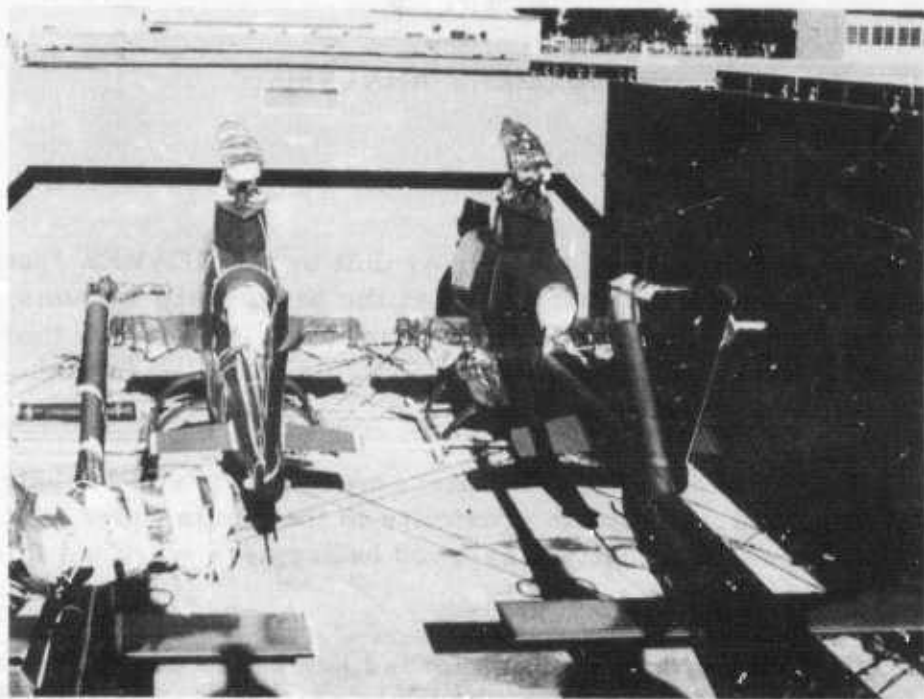

Figure 45. Two AH-1G and Two UH-1H Helicopters Loaded in SEABEE Barge.



Figure 46. Three Unpreserved Civilian Helicopters Shipped in SEABEE Barge.

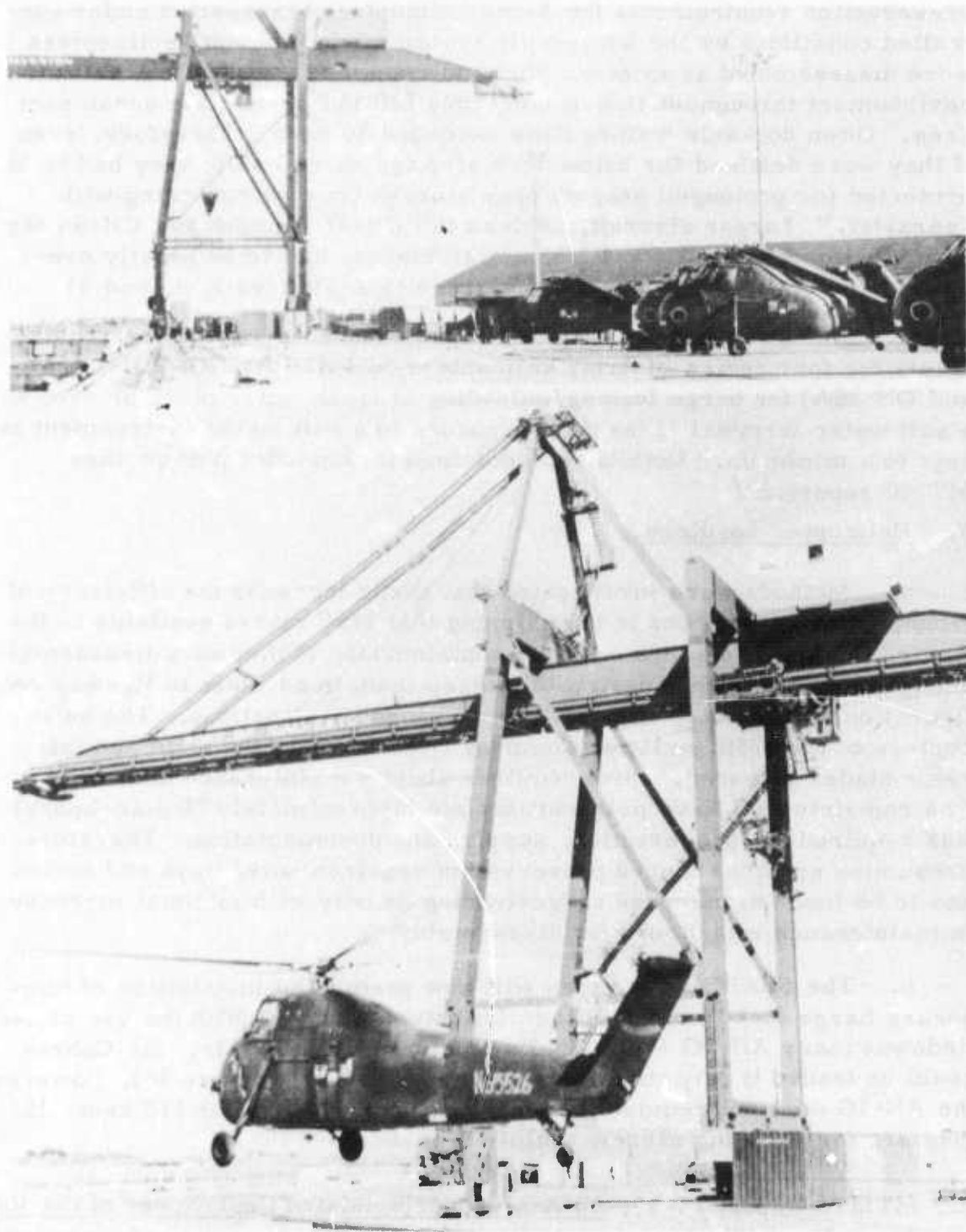

Figure 47. Civilian Helicopters Unloaded From SEABEE Barges Onto Galveston, Texas, Dock and Flown Away.

b. Coordination was effected with AVSCOM to achieve compatible preservation requirements for Army helicopters transported under controlled conditions by the barge-ship systems. In the past, helicopters were disassembled at an ocean port and remained exposed to a salt air environment throughout transit until they left the destination ocean port area. Often dockside waiting time exceeded 30 days. Therefore, even if they were destined for below deck stowage aboard ship, they had to be protected for prolonged seaport open storage time by cocooning with "spraylat." Larger aircraft, such as the CH-47 Chinook and CH-54 Sky Crane helicopters and OV-1 Mohawk airplanes, had to be heavily preserved and covered for open deck storage (See Figures 3, 4, and 5).

c. AVSCOM subsequently developed reduced preservation requirements for four series of Army helicopters (CH-47, AH-1G, UH-1H/M, and OH-58A) for barge loading/unloading at fresh water ports or even at a salt water terminal if the time exposure to a salt water environment is kept to a minimum. Details are contained in Appendix A of another MTMC report.^{15/}

3. Helicopter Loadings.

a. Methods were investigated that would increase the efficiency of transporting helicopters in the shipping that MSC makes available to the Army. Many helicopters could be containerized if they were disassembled enough, but it is highly desirable to keep them in as close to flyaway configuration as possible, especially in contingency situations. The helicopters of the 175th Aviation Company (AH) had only the main and tail rotor blades removed, which requires about 4 maintenance man-hours. The remaining US Navy preparation time (approximately 70 man-hours) was required for preservation, supply, and documentation. Therefore, presuming greatly reduced preservation requirements, ways and means had to be found to increase barge-loading density with minimal increase in maintenance man-hours for disassembly.

b. The SEABEE operators will now permit the installation of temporary barge deck tiedown fittings for future moves. With the use of deck tiedowns many AH-1G Cobra loading options are available. Six Cobras could be loaded if only the rotor blades are removed (Figure 48). However, the AH-1G does not require the stub wings for flight under 110 knots;^{16/} they are for carrying stores, mainly ordnance.

^{15/} MTMTS Report 74-19, An Analysis of Simulated Deployment of the US Army Airmobile Division, Military Traffic Management and Terminal Service, Washington, DC 20315, May 1974.

^{16/} Source: AH-1G System Staff Officer, Office of the Assistant Chief of Staff for Force Development, DA.

c. With the stub wings removed it is possible to load 10 AH-1G attack helicopters in the SEABEE barge (Figure 49). Removal of the wings permits the installation of a fuselage-mounted 16,700-pound-rated tiedown fitting, which is habitually used for air transport of the Cobra (Figure 50). (The tiedown fitting under the wing is only rated for 500 pounds' tension.) This disassembly requires 1 more man-hour over the 4 man-hours required to remove or install the rotor blades. One additional man-hour of disassembly to remove the synchronized elevator on the tail boom will permit the stowage of 14 Cobras (Figure 51). The total disassembly time is now 6 man-hours (three men working 2 hours) but only 5 man-hours would be required for reassembly to fly away. The wings could be reinstalled in 1 man-hour after the helicopters have reached their new base. Comparing reassembly times for flyaway, it is seen that the 1 additional man-hour per helicopter when shipping 14 Cobras per barge is not much of a penalty over the 4 man-hours required when shipping only six per barge.

d. Now, the widest part of the AH-1G Cobra is the 86-inch width of the landing skids. By substituting a 56-inch-wide air transportability skid (Figure 52), it is estimated that 23 Cobras could be loaded per barge. Since this AVSCOM-provided skid also lowers the profile (Figure 53) there would be a cost savings in reduced cube for administrative moves. However, this involves an additional 8 man-hours per helicopter and the procurement of equipment not organic to an aviation unit. It therefore appears that the loading of 14 Cobras per SEABEE barge at a return-to-flight penalty of only 1 maintenance man-hour is the optimum. This would be an increase of barge utilization of three and one-half times over the initial SEABEE move.

e. Installation of temporary tiedown fittings in the SEABEE barge to accommodate 14 Cobras could be made by welding crews prior to the shipment date (Figure 54). Some rotor blade containers could be placed in the barge prior to helicopter loading and tiedown. Use of the deck fittings and the air transportability fitting would allow optimum tiedown angles and greatly reduce, if not eliminate, the need for wood dunnaging (Figure 55).

f. A LASH lighter could stow 8 AH-1G Cobras with minimal disassembly (Figure 56). The deck fittings could be installed prior to shipment (Figure 57) and a number of rotor blade containers pre-positioned before helicopter loading and tiedown (Figure 58). However, LASH lighters should only be used if there are no SEABEE barges available. Because of the smaller 44-foot hatch opening the helicopters must be loaded carefully to get under the 8-foot upper end decks. The height of a Cobra is 12 feet 5-1/2 inches, and the height of a LASH lighter under the hatch cover is only 11 feet 7-1/2 inches. This permits only the center

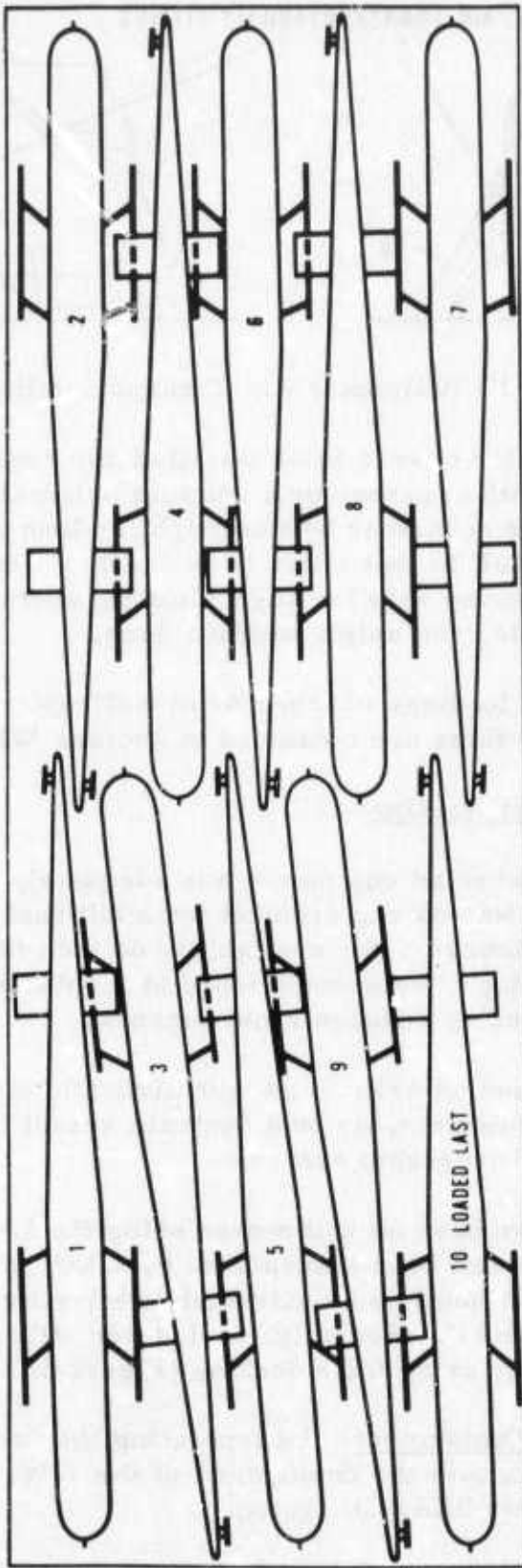

Figure 49. Stowage of 10 AH-1G Helicopters in SEABEE Barge.

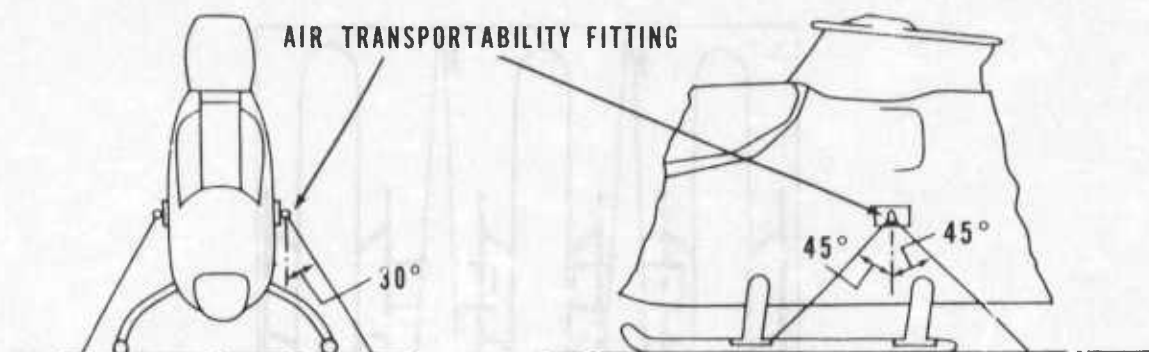

Figure 50. AH-1G Helicopter Air Transportability Tiedown Fitting.

one of the three hatch covers to be installed and requires that the open ends be covered with neoprene or a suitable polyurethane. AVSCOM does not require that the coverings be watertight so long as the loaded lighters are not exposed at all to salt water or to a salt air environment for more than a few hours during ship loading/unloading operations. These lighters must be stowed below the ship's weather deck.

g. Proposed loadings of other Army helicopters and detailed procedures for barge-ships are contained in another MTMC report.^{17/}

4. Unit Equipment Loading.

a. The unit wheeled equipment was adequately restrained for marine transport. There was no requirement for additional tiedown fittings in the barge deck. However, the availability of such fittings would have permitted the loading to be accomplished at a substantial savings through eliminating or reducing dunnage requirements.

b. Although not as critical as with aircraft, the elimination of open deck stowage of equipment, as on a Seatrain vessel (Figure 59), is a definite asset of the barge-ship systems.

c. There have been no unit moves using the LASH system although military equipment has been transported by LASH (Figure 60). The lighters were tested and found to be extremely well-suited for the transport of ammunition (Figure 61). Recently, 54 1/4-ton utility trucks were shipped in a LASH lighter by using false decking (Figure 62).

5. Potential Unit Deployment. Incorporating the findings of this analysis, it is possible to evaluate the deployment of the 175th Aviation Company (AH) by the complete SEABEE system.

^{17/} Op. Cit., MTMTS Report 74-19, Appendix A.

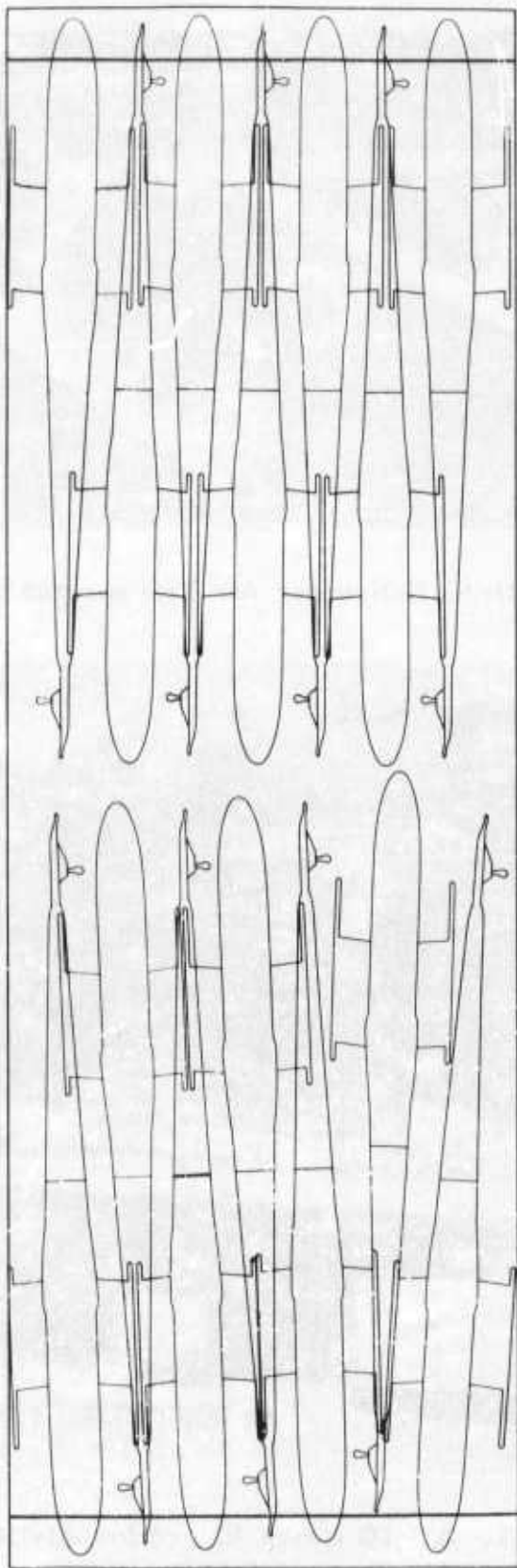

Figure 51. Stowage of 14 AH-1G Cobras in SEABEE Barge.

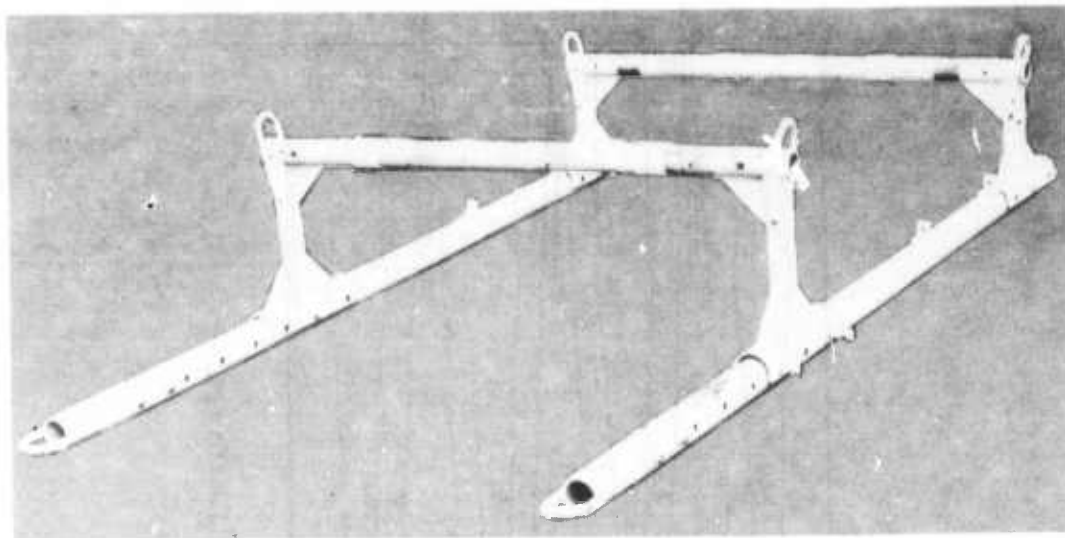

Figure 52. AH-1G Helicopter Air Transportability Skid.

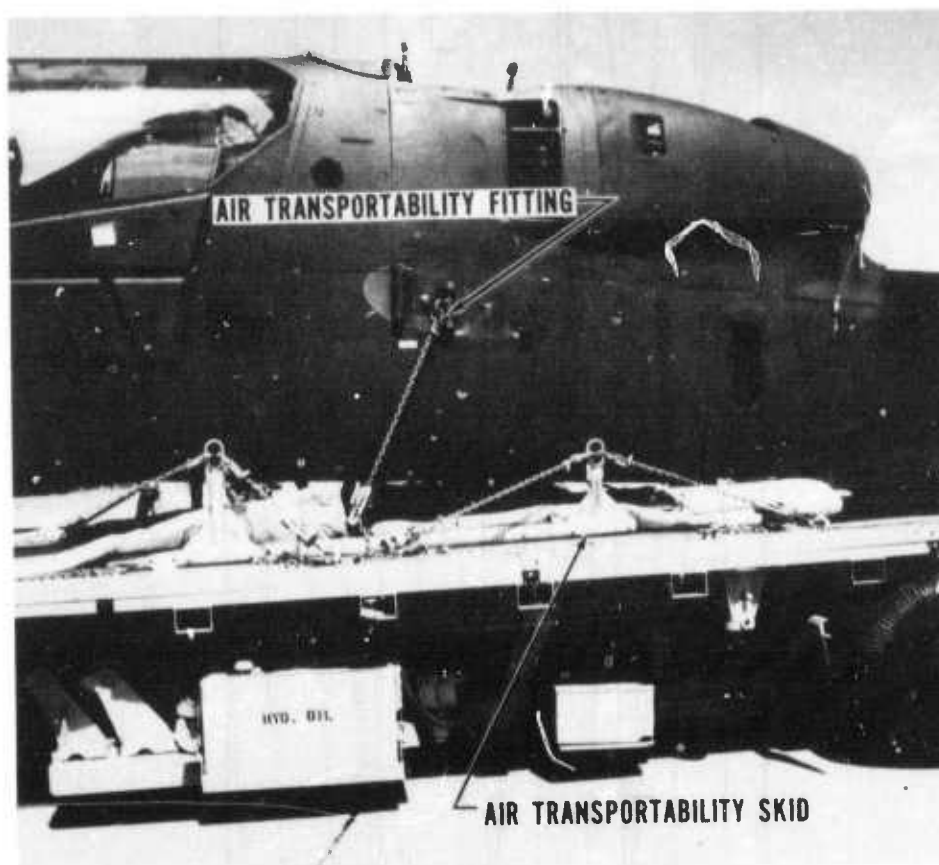

Figure 53. AH-1G Cobra Rigged for Airlift on Air Transportability Skid.

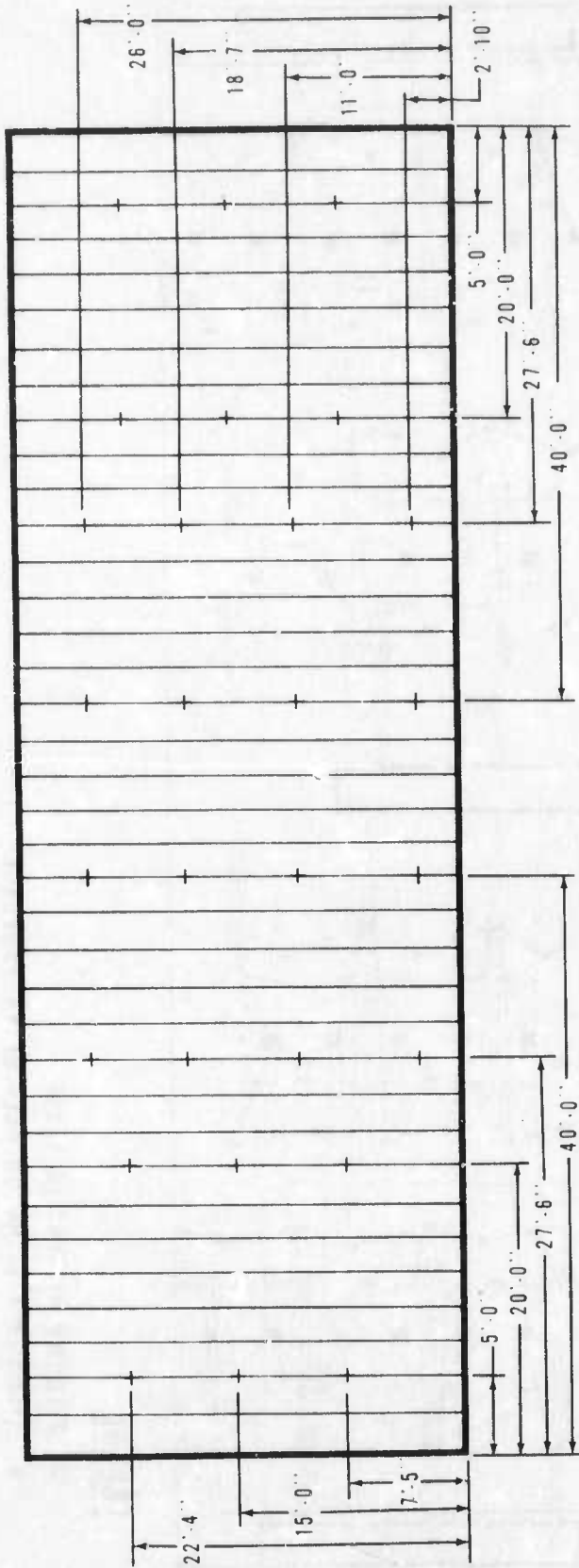
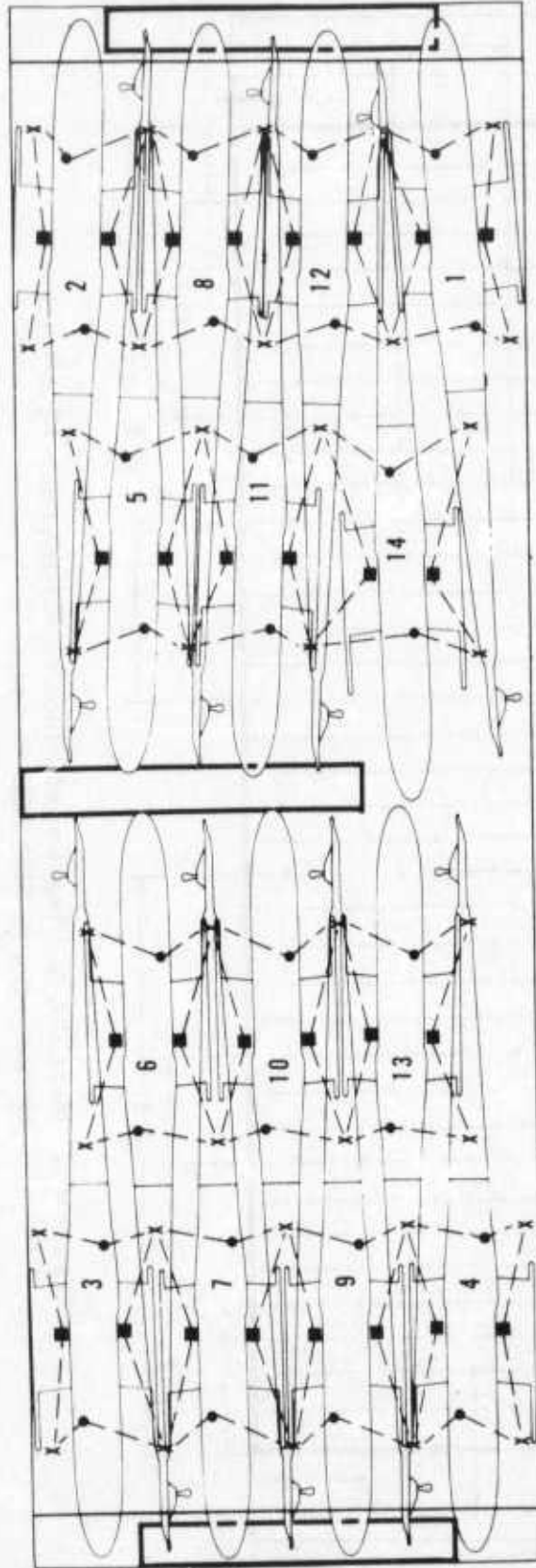

Figure 54. Installation Diagram of Tiedown Fittings for 14 AH-1G Helicopters in SEABEE Barge.



LEGEND

- x TIEDOWN FITTING IN BARGE
- TIEDOWN FITTING ON HELICOPTER FUSELAGE
- AIR TRANSPORTABILITY FITTING
- TIEDOWN DEVICE OR CABLE

Figure 55. Loading Sequence and Tie-down Diagram for 14 AH-1G Helicopters in SEABEE Barge.

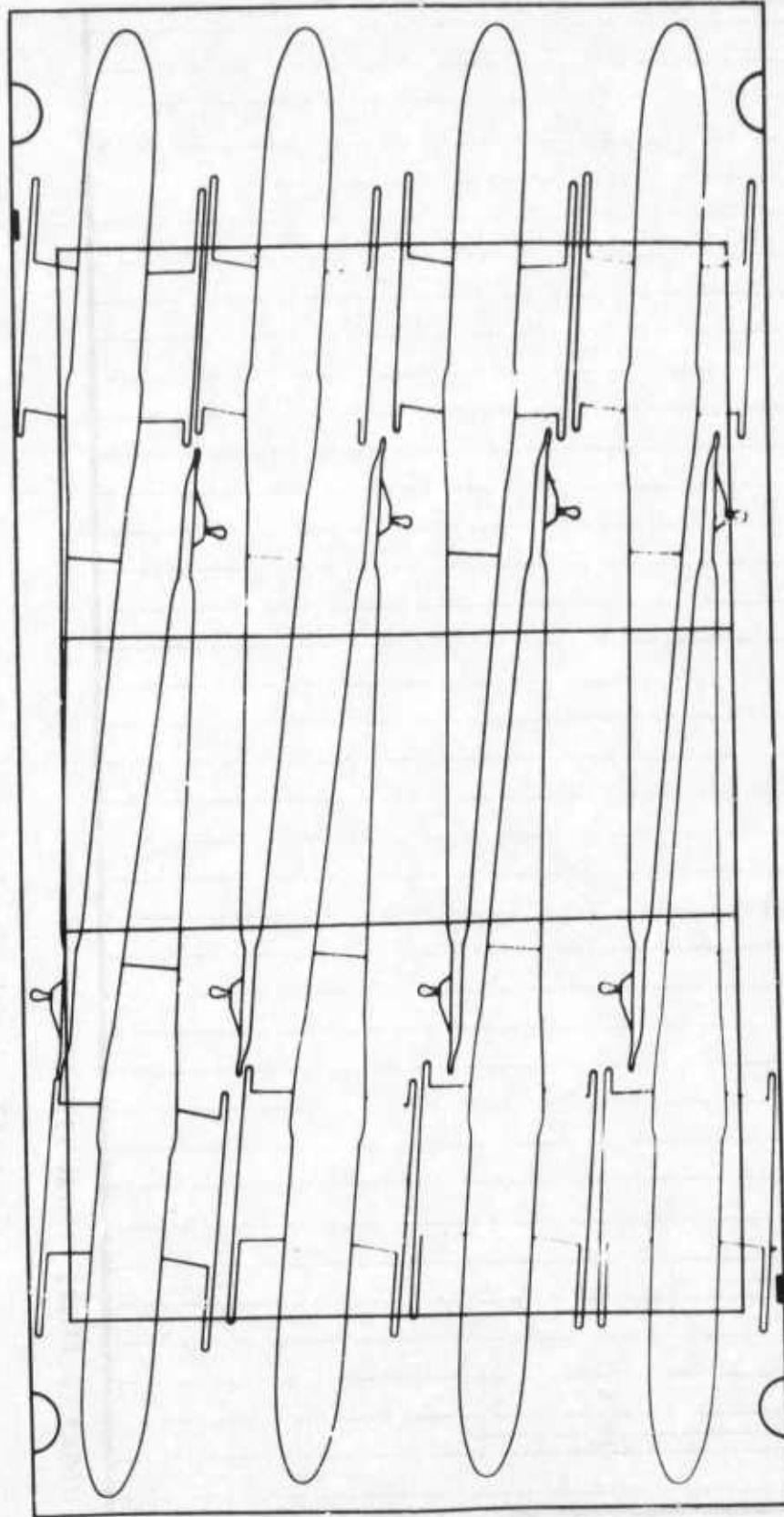
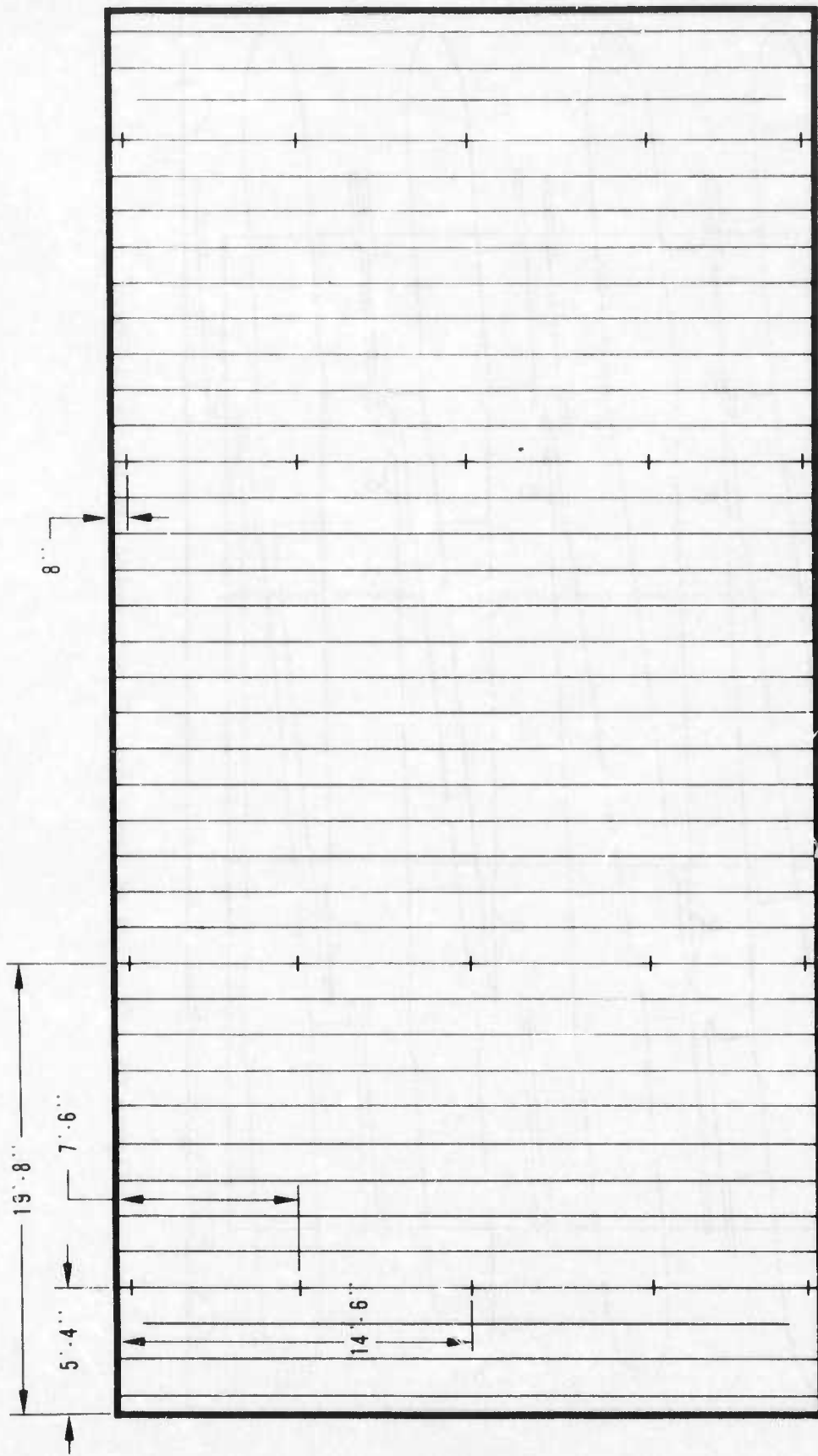
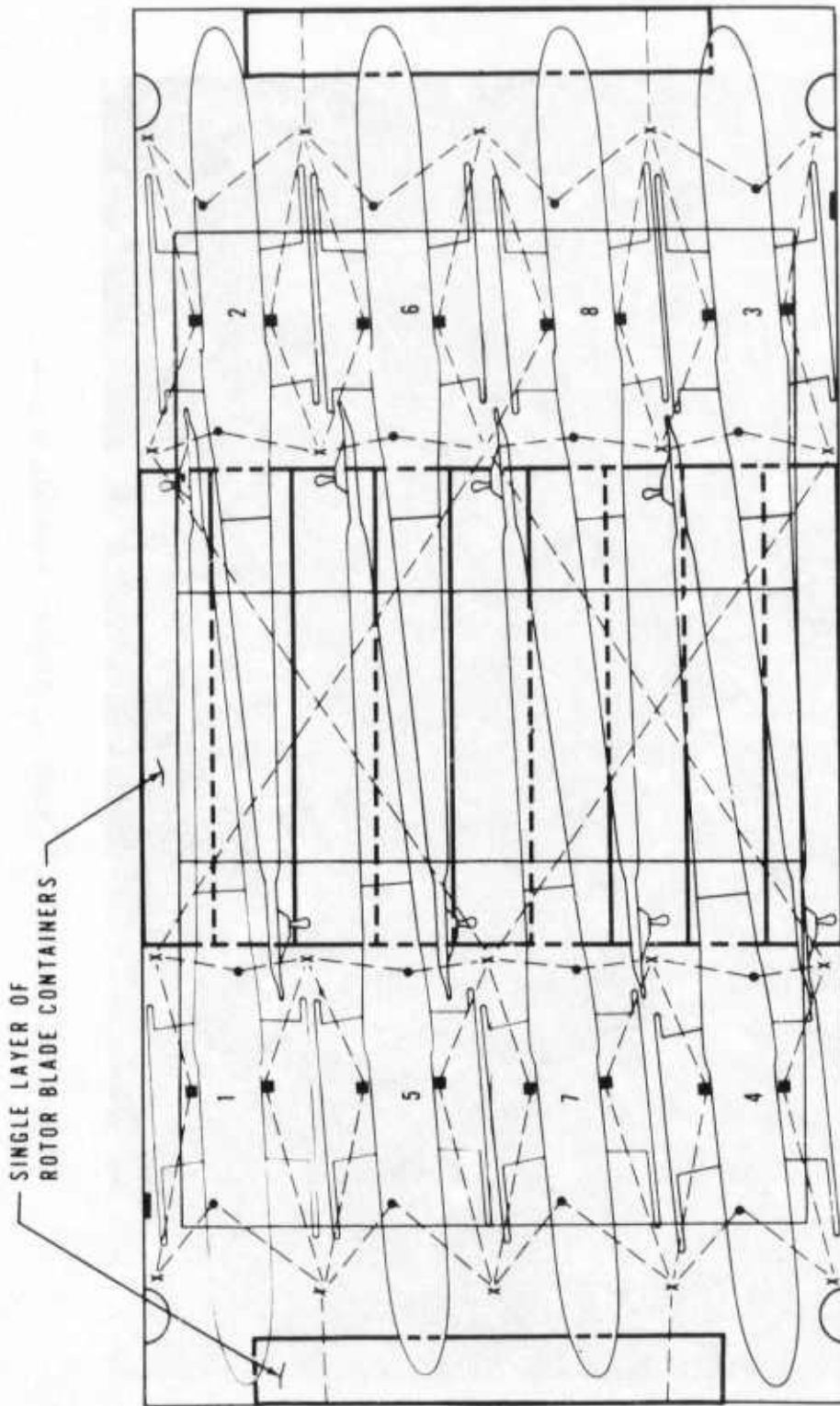

Figure 56. Stowage of Eight AH-1G Helicopters in LASH Lighter.



TIEDOWN LOCATIONS TYPICAL BOTH ENDS

Figure 57. Installation Diagram of Tiedown Fittings for Eight AH-1G Helicopters in LASH Lighter.



LEGEND

- x TIEDOWN FITTING IN LIGHTER
- TIEDOWN FITTING ON HELICOPTER FUSELAGE
- AIR TRANSPORTABILITY FITTING
- TIEDOWN DEVICE OR CABLE

Figure 58. Loading Sequence and Tiedown Diagram for Eight AH-1G Helicopters in LASH Lighter.



Figure 59. Military Equipment Aboard Seatrain Vessel.

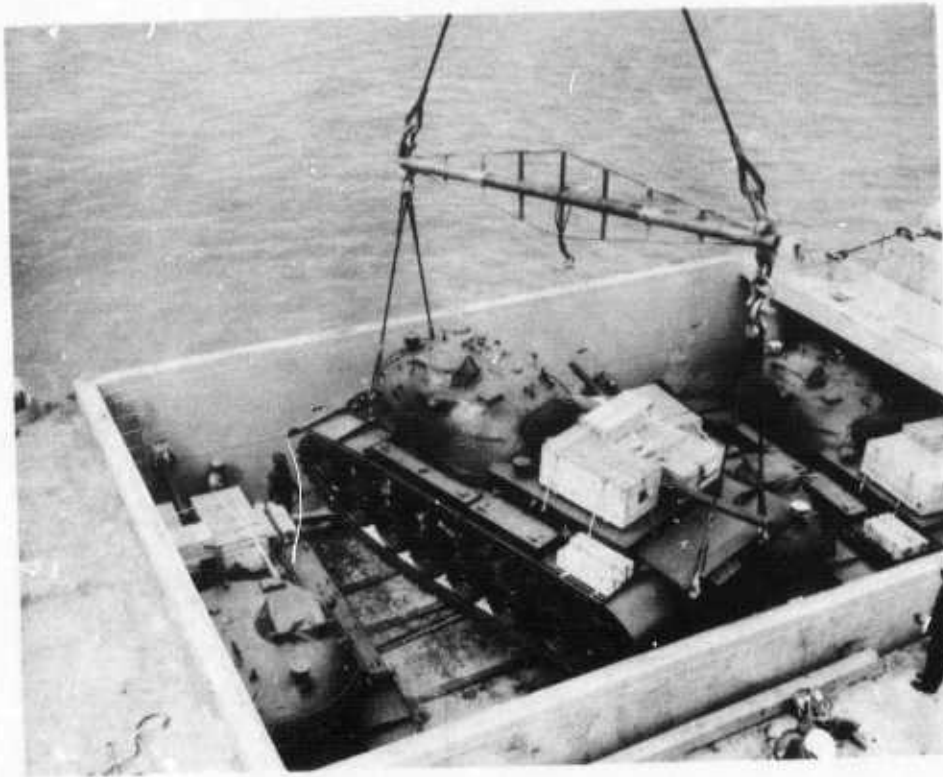

Figure 60. M48 Tanks Being Loaded in LASH Lighter.

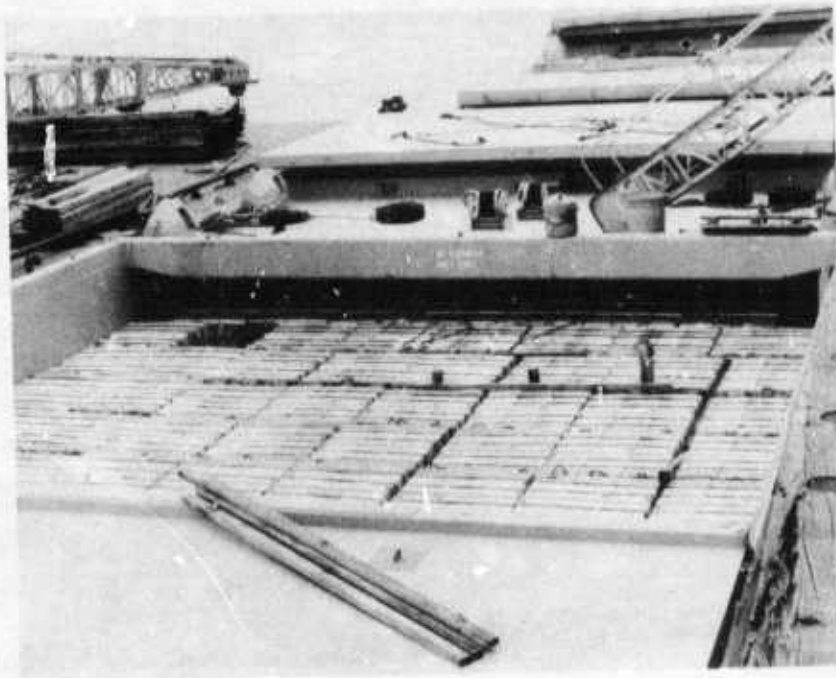

Figure 61. 105-mm Ammunition Loaded in LASH Lighter.

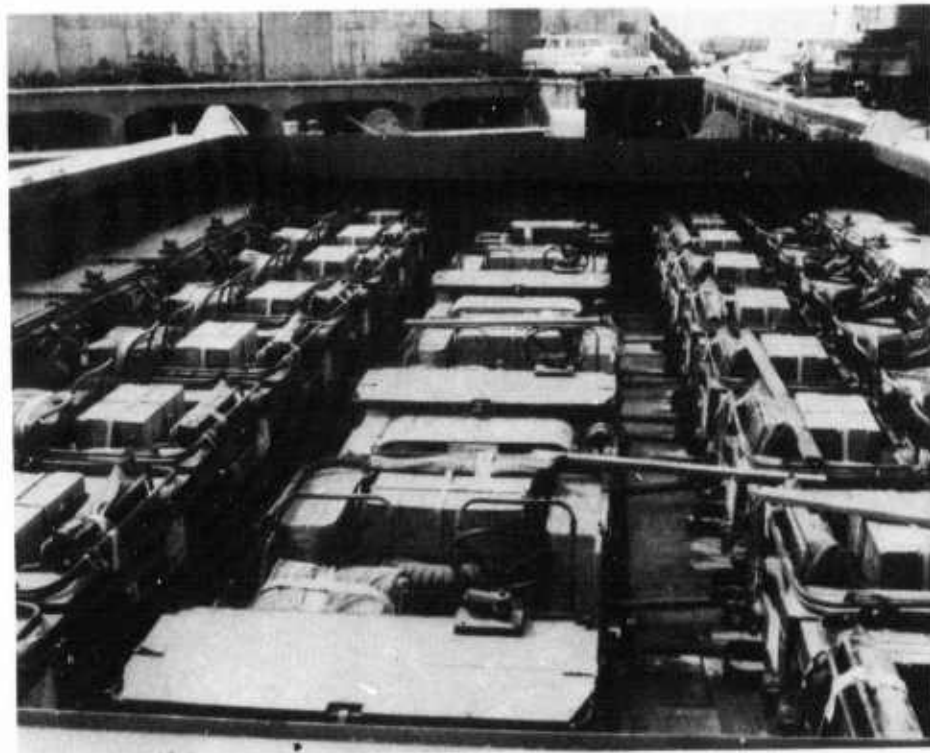
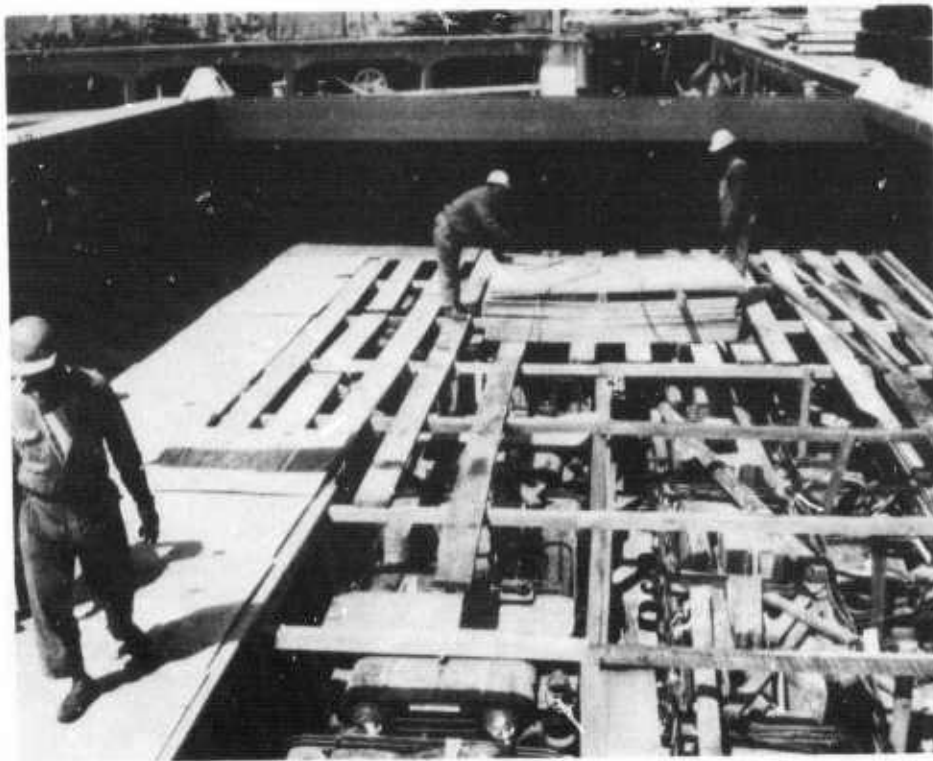

Figure 62. Loading 54 1/4-Ton Utility Trucks in LASH Lighter.

a. Assumptions:

- (1) AVSCOM reduced preservation procedures are used.
- (2) The 14 AH-1G per barge loading configuration is used.

b. Conclusions. It is concluded that:

(1) No helicopters would make the 5-hour flight to NAS Pensacola saving the cost of 115 flying hours, TDY funds, commercial air fare for flight crews, and the US Navy charges for oversea preparation.

(2) The helicopters would be prepared for shipment at the docks by unit personnel at Louisville, Kentucky, after a 15-minute flight from Fort Knox. Alternatively, they could be prepared at Fort Knox and trucked to dockside at Louisville for loading in SEABEE barges along with the unit equipment. The entire unit would be towed down river to New Orleans for loading on the mother ship (Figure 63).

(3) There would be a single through bill of lading from Louisville to Rheinau via the SEABEE system.

(4) Only 6 SEABEE barges would be required instead of 10, a decrease of 40 percent. Barge loads would be as follows:

Barge 1 - 14 AH-1G helicopters.

Barge 2 - 7 AH-1G and 2 UH-1H helicopters.

Barge 3 - Heavy vehicles.

Barge 4 - Heavy vehicles.

Barge 5 - 31 CONEX containers (including the secure CONEX) and assorted vehicles/equipment.

Barge 6 - Utility vehicles with rotor blade boxes, stub wings, and elevators stowed on a second deck.

(5) There would be a substantial cost savings to the US Government for the move of an attack helicopter aviation company.

6. Deployment Cost Comparisons.

a. In November 1972, the 334th Aviation Company (Attack Helicopter) deployed from Fort Knox to Hanau, Germany. The unit was identical with

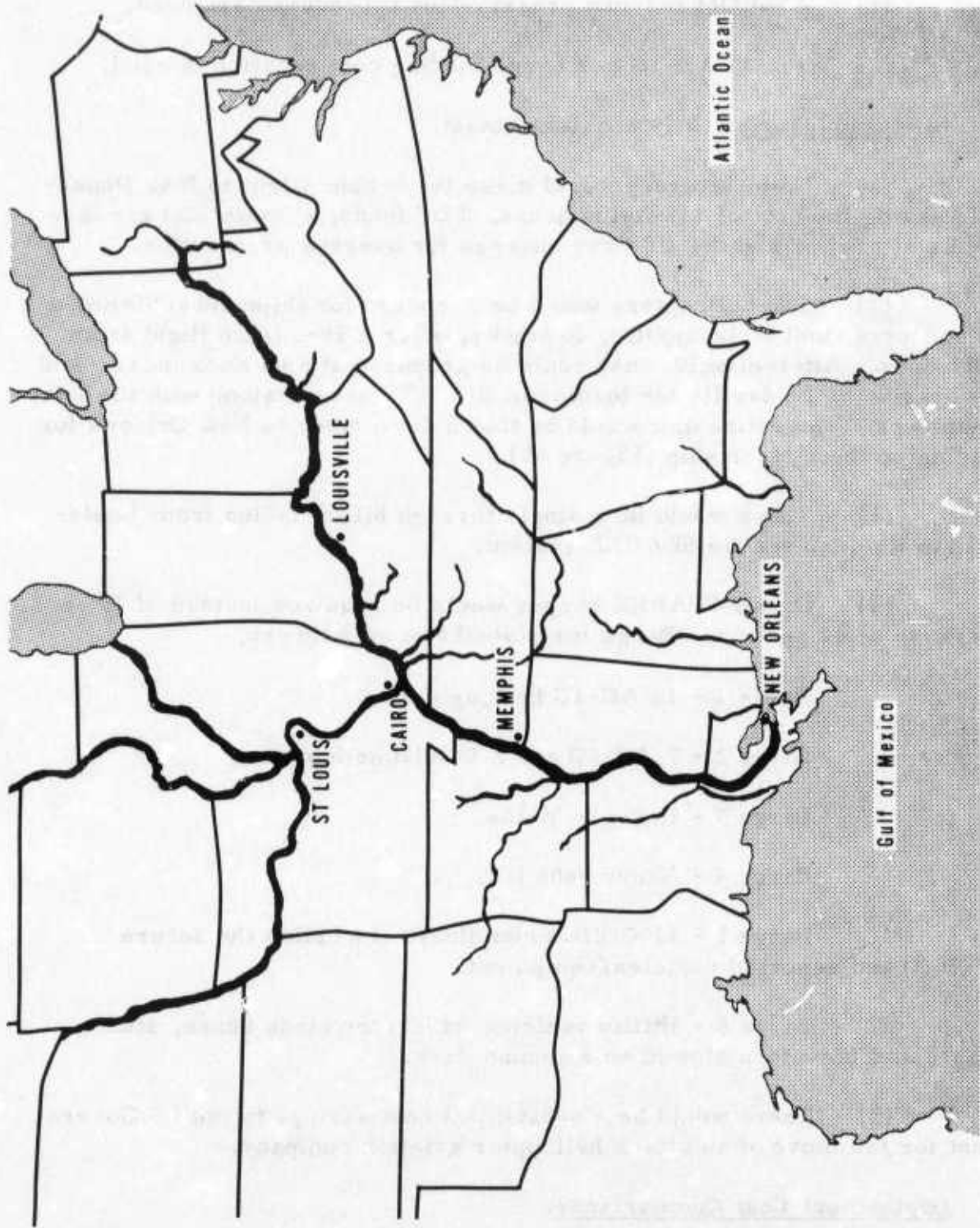

Figure 63. Ohio and Mississippi River Systems.

the 175th Aviation Company (AH); their billing tonnages differed by only 4 STON and 93 MTON. The CONUS routing was similar except that the helicopters were loaded aboard an MSC time-chartered Seatrain vessel, at Pensacola (Figure 64). Off-loading was at Bremerhaven, Germany, where the helicopters were repaired and prepared for flight. The unit equipment was moved by rail to Hanau. The similarity of these two moves provides an excellent comparison of SEABEE versus a conventional ship. However, even though the same type of unit moved from the same post through the same CONUS ports within months of each other to nearby locations in Germany, this comparison is not predictive because the SEABEE system was not used to its full extent. Therefore, the estimated cost of a potential move solely by the SEABEE system is added to the comparison.

b. The reported billing costs to the US Government (not the US Army) for the two deployments and the estimated costs of a potential SEABEE deployment are contained in Table 1.

c. One cost comparison^{18/} indicated that the deployment of the 175th Aviation Company by SEABEE cost \$8,365 less than the 334th Aviation Company deployment by an MSC time-chartered Seatrain vessel. The Seatrain cost included the \$44,014 cost of replacement parts necessitated by accidental damage of some helicopters by salt water. Since this was a below-deck open-valve accident and not a normal occurrence with Seatrain vessels, this cost was not included in the analysis. Therefore, in these two cases, the deployment cost by Seatrain was approximately 15 percent less (\$35,648) than the SEABEE move. However, if the 175th Aviation Company had used the complete SEABEE system from Louisville to Mannheim, it is estimated that the cost would have been about 11 percent less (\$22,103) than the Seatrain deployment and almost 25 percent less (\$57,751) than the combined rail and SEABEE move. Note that all savings are not in transportation costs. Much is accrued by reduced TDY and helicopter preparation costs.

^{18/} Op. Cit., USAREUR Briefing, BARTAP Conference.

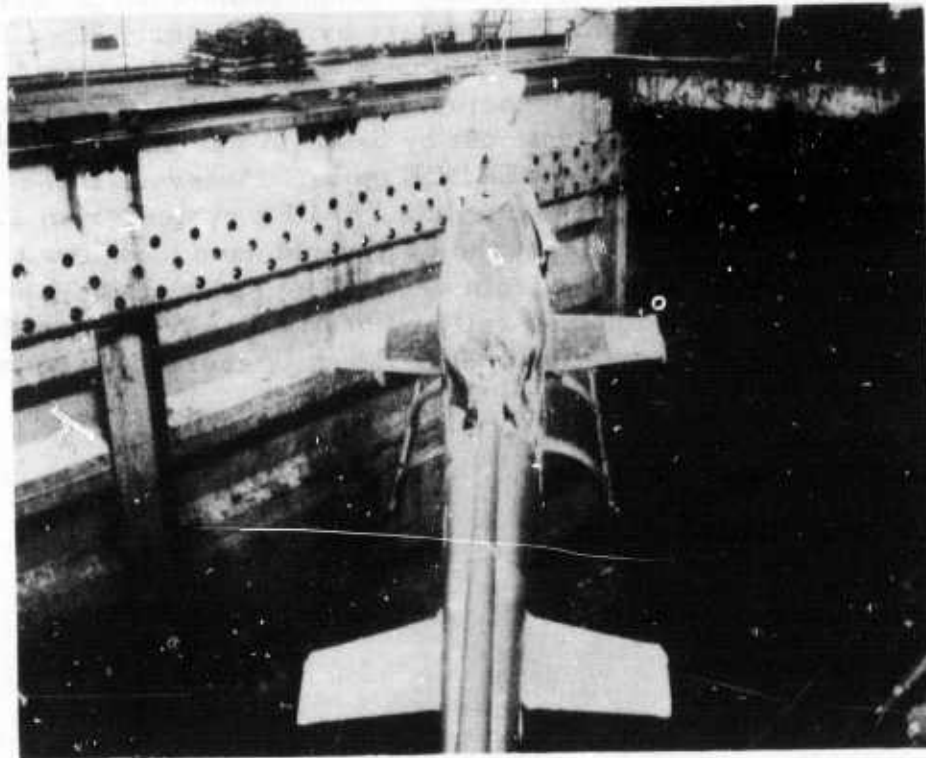

Figure 64. AH-1G Helicopters Being Loaded Aboard Seatrain Vessel.

TABLE 1
DEPLOYMENT COST COMPARISONS

	334th Avn Co (AH)	175th Avn Co (AH)	
	Rail-Seatrain	Rail-SEABEE	SEABEE (est as of Jan 73)
Rail to POE ^{a/}	\$ 22,451	\$ 23,841	\$ 0
Hel Flt to POE ^{b/}	6,900	6,900	345
TDY	10,121	10,121 ^{c/}	0
Hel Prep	11,500	11,500	0
POE-Stevedore (Cgo)	2,845	4,259	2,130 ^{d/}
(Hel)	4,618	5,738	2,869 ^{d/}
POE-Material (Cgo)	143 ^{e/}	3,106	3,107
(Hel)	0 ^{e/}	3,069	1,000 ^{f/}
POE-Equip Rental	623	140	140
POE-Handling Chg	886	857	857
CONUS Subtotal	(\$ 60,087)	(\$ 69,531)	(\$ 10,448)
Ocean Trans Subtotal	(\$108,438) ^{g/}	(\$145,257) ^{h/}	(\$152,706) ^{i/}
POD-Total Chg ^{j/}	\$ 4,598	\$ 2,374	\$ 2,374
Hel Prep	8,604	8,267	2,150 ^{k/}
TDY	4,917	2,479	2,479
Flt to Dest	2,625	966	966
Rail from POD	9,044	5,087	5,087
Theater Subtotal	(\$ 29,788)	(\$ 19,173)	(\$ 13,056)
Total	\$198,313	\$233,961	\$176,210

^{a/} Adjusted payments by US Army Finance Support Agency for 396 STON, 175th Avn Co and 379 STON for 334th Avn Co.

^{b/} Based on DA Comptroller cost of \$60/ft hr for all Army aircraft.

^{c/} \$22,005 cost, which included TDY to Europe, was reduced to amount Ft Knox paid for 334th Avn Co TDY.

^{d/} River port costs estimated to be at least 50 percent less than ocean ports. (Sources: Gulf Outport, MTMC and Lykes Bros Lines, New Orleans, LA).

^{e/} Numerous tiedown fittings on Seatrain vessels greatly reduced lashing and dunnage requirements.

^{f/} Estimate based on temporary deck tiedown fittings installed.

^{g/} 5,238 MTON; average of \$20.70 per MTON not indicative for Seatrain since it is time-chartered and cost is proportionate to total cargo carried.

^{h/} 5,331 MTON; average of \$27.25 per MTON.

^{i/} Based on paid cost of 175th Avn Co plus estimated difference between cost from Gulf to Mannheim and Louisville to Mannheim.

^{j/} Includes stevedore and port handling charges.

^{k/} Based on \$8,975 man-hour rate for 175th Avn Co and estimated 239.5 man-hours required.

DISTRIBUTION

Commander Military Traffic Management Command ATTN: MTMC-SA Washington, DC 20315	(25)
Commander Eastern Area, Military Traffic Management Command Bayonne, NJ 07002	(10)
Commander Western Area, Military Traffic Management Command Oakland Army Base Oakland, CA 94626	(10)
Commander Military Sealift Command Washington, DC 20390	(10)
Commander US Army Materiel Command 5001 Eisenhower Avenue Alexandria, VA 22304	(5)
Commander Sheppard Technical Training Center (ATC) USAF School of Applied Aero Space Science (TTRM) Sheppard Air Force Base, Texas 76311	(3)
Commander US Army Aviation Systems Command ATTN: AMSAV-QN 12th and Spruce Streets Saint Louis, MO 63102	(5)
Deputy Chief of Staff for Logistics Department of the Army Washington, DC 20310	(5)
Deputy Chief of Staff for Military Operations Department of the Army ATTN: DAMO-ODU Washington, DC 20310	(5)

Commandant
 US Army Transportation School
 Fort Eustis, VA 23604 (5)

Commander
 US Army Logistics Center
 Fort Lee, VA 23801 (5)

Commandant
 US Army Command and General Staff College
 Fort Leavenworth, KS 66027 (3)

Commandant
 US Army War College
 Carlisle Barracks, PA 17013 (3)

Commandant
 Armed Forces Staff College
 1150 Corregidor Avenue
 Norfolk, VA 23511 (3)

AFLC/CC
 Wright-Patterson Air Force Base, OH 45323 (3)

OAMA/CC
 Hill Air Force Base, UT 84401 (3)

Commander
 US Army Training and Doctrine Command
 Fort Monroe, VA 23351 (3)

Commander
 US Naval School, Transportation Management
 Oakland, CA 94600 (3)

Commandant
 US Marine Corps, Code COS
 Washington, DC 20380 (3)

Commandant
 US Naval War College
 Newport, RI 02840 (3)

Commandant
 Industrial College of the Armed Forces
 Washington, DC 20315 (3)

Commandant
National War College
Washington, DC 20315 (3)

Commander in Chief
US Army Europe
APO NY, NY 09403 (3)

Commander in Chief
US Army Pacific
APO San Francisco, CA 96558 (3)

Commander
US Army Transportation Command
APO NY, NY 09451 (3)

Commander
US European Command
ATTN: TRANS (SIP-SIP-6)
APO NY, NY 09128 (3)

Defense Logistics Studies Information Exchange
US Army Logistics Management Center
Fort Lee, VA 23801 (2)

Defense Documentation Center
Cameron Station
Alexandria, VA 22314 (2)

UNCLASSIFIED

Security Classification

DOCUMENT CONTROL DATA - R & D

(Security classification of title, body of abstract and indexing annotation must be entered when the overall report is classified)

1. ORIGINATING ACTIVITY (Corporate author) Military Traffic Management Command Transportation Engineering Agency Newport News, Virginia 23606		2a. REPORT SECURITY CLASSIFICATION UNCLASSIFIED	
		2b. GROUP	
3. REPORT TITLE An Analysis of the Initial Deployment of a US Army Unit by a Barge-Ship System			
4. DESCRIPTIVE NOTES (Type of report and Inclusive dates) Final Report			
5. AUTHOR(S) (First name, middle initial, last name) William H. Scanlan, LTC, TC			
5. REPORT DATE April 1975		7a. TOTAL NO. OF PAGES 80	7b. NO. OF REFS
8a. CONTRACT OR GRANT NO.		9a. ORIGINATOR'S REPORT NUMBER(S) MTMC Report 75-16	
b. PROJECT NO.		9b. OTHER REPORT NO(S) (Any other numbers that may be assigned this report)	
c.			
d.			
10. DISTRIBUTION STATEMENT Distribution limited to US Government agencies only; test and evaluation of commercial products and military hardware (30 April 1975). Other requests for this document must be referred to Commander, Military Traffic Management Command, ATTN: MTMC-SA, Washington, DC 20315.			
11. SUPPLEMENTARY NOTES		12. SPONSORING MILITARY ACTIVITY	
13. ABSTRACT This study is a conceptual analysis of ways and means to improve the oversea transportability of US Army units and equipment in both peacetime and contingency situations with the modern sealift assets presently available. Its objectives are to provide a documentary narrative of the initial use of a barge-ship system to deploy a US Army tactical unit and to identify technical and operational shortcomings in order to recommend improvements in the state of the art. It was found that the responsiveness, efficiency, and economy of US Army oversea unit moves, especially those deploying with helicopters, could be significantly improved by implementing the conceptual loadings and use of the barge-ship systems.			

DD FORM 1473
1 NOV 65

REPLACES DD FORM 1473, 1 JAN 64, WHICH IS OBSOLETE FOR ARMY USE.

UNCLASSIFIED

Security Classification

UNCLASSIFIED

Security Classification

14. KEY WORDS	LINK A		LINK B		LINK C	
	ROLE	WT	ROLE	WT	ROLE	WT
Barge-Ship Systems Helicopter: Disassembly Loading Preservation Lighter Aboard Ship (LASH) Sea Barge (SEABEE) Seatrail Vessels Unit Deployment 175th Aviation Company (Attack Helicopter) 334th Aviation Company (Attack Helicopter)						

UNCLASSIFIED

Security Classification

UNCLASSIFIED

Security Classification

DOCUMENT CONTROL DATA - R & D

(Security classification of title, body of abstract and indexing annotation must be entered when the overall report is classified)

1. ORIGINATING ACTIVITY (Corporate author) Military Traffic Management Command Transportation Engineering Agency Newport News, Virginia 23606		2a. REPORT SECURITY CLASSIFICATION UNCLASSIFIED	
		2b. GROUP	
3. REPORT TITLE An Analysis of the Initial Deployment of a US Army Unit by a Barge-Ship System			
4. DESCRIPTIVE NOTES (Type of report and inclusive dates) Final Report			
5. AUTHOR(S) (First name, middle initial, last name) William H. Scanlan, LTC, TC			
5. REPORT DATE April 1975		7a. TOTAL NO. OF PAGES 80	7b. NO. OF REFS
5a. CONTRACT OR GRANT NO.		9a. ORIGINATOR'S REPORT NUMBER(S) MTMC Report 75-16	
b. PROJECT NO.		9b. OTHER REPORT NO(S) (Any other numbers that may be assigned this report)	
c.			
d.			
10. DISTRIBUTION STATEMENT Distribution limited to US Government agencies only; test and evaluation of commercial products and military hardware (30 April 1975). Other requests for this document must be referred to Commander, Military Traffic Management Command, ATTN: MTMC-SA, Washington, DC 20315.			
11. SUPPLEMENTARY NOTES		12. SPONSORING MILITARY ACTIVITY	
13. ABSTRACT This study is a conceptual analysis of ways and means to improve the oversea transportability of US Army units and equipment in both peacetime and contingency situations with the modern sealift assets presently available. Its objectives are to provide a documentary narrative of the initial use of a barge-ship system to deploy a US Army tactical unit and to identify technical and operational shortcomings in order to recommend improvements in the state of the art. It was found that the responsiveness, efficiency, and economy of US Army oversea unit moves, especially those deploying with helicopters, could be significantly improved by implementing the conceptual loadings and use of the barge-ship systems.			

DD FORM 1473
1 NOV 55

REPLACES DD FORM 1473, 1 JAN 54, WHICH IS OBSOLETE FOR ARMY USE.

UNCLASSIFIED

Security Classification

UNCLASSIFIED

Security Classification

14 KEY WORDS	LINK A		LINK B		LINK C	
	ROLE	WT	ROLE	WT	ROLE	WT
Barge-Ship Systems Helicopter: Disassembly Loading Preservation Lighter Aboard Ship (LASH) Sea Barge (SEABEE) Seatrain Vessels Unit Deployment 175th Aviation Company (Attack Helicopter) 334th Aviation Company (Attack Helicopter)						

UNCLASSIFIED

Security Classification