

UNCLASSIFIED

AD NUMBER

ADB008413

LIMITATION CHANGES

TO:

Approved for public release; distribution is unlimited.

FROM:

Distribution authorized to U.S. Gov't. agencies only; Test and Evaluation; OCT 1975. Other requests shall be referred to Space and Missile Systems Organization, Attn: SMSDI-STINFO, Los Angeles, CA 90045.

AUTHORITY

SAMSO, USAF lt, 17 Jun 1977

THIS PAGE IS UNCLASSIFIED

THIS REPORT HAS BEEN DELIMITED
AND CLEARED FOR PUBLIC RELEASE
UNDER DOD DIRECTIVE 5200.20 AND
NO RESTRICTIONS ARE IMPOSED UPON
ITS USE AND DISCLOSURE.

DISTRIBUTION STATEMENT A

APPROVED FOR PUBLIC RELEASE,
DISTRIBUTION UNLIMITED.

②

NAVSTAR GLOBAL POSITIONING SYSTEMS SPECIAL STUDIES AND ENGINEERING PROGRAM

VOLUME III
FINAL REPORT

Prepared by:

James J. Spilker, Jr.
Francis D. Natali
Jackson T. Witherspoon

October 25, 1975

[Handwritten signature and stamp]

AD B 008413

SPACE AND MISSILE SYSTEMS ORGANIZATION (AFSC)
LOS ANGELES AIR FORCE STATION
LOS ANGELES, CALIFORNIA

DISTRIBUTION STATEMENT B

Distribution limited to U.S. Government agencies only; Test and Evaluation; October 1975. Other requests for this document must be referred to SAMSO (YEE).

P.O. Box 92960, Worldway Postal Center, Los Angeles, CA. 90009

AD No. _____
DDC FILE COPY



STANFORD TELECOMMUNICATIONS INC.

1161 San Antonio Road • Mountain View, California 94043 • (415) 964-9290

The final report was submitted by Stanford Telecommunications, Inc., 1161 San Antonio Road, Mountain View, California 94043 under Contract No. FO4701-74-C-0310 with Space and Missile Systems Organization, Air Force Systems Command, Los Angeles Air Force Station, Los Angeles, California. Mr. Steven Lagna was the Project Engineer.

This technical report has been reviewed and is approved for publication.



Steven Lagna, GS-12
Project Engineer

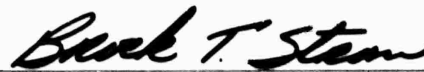

Brock T. Strom, Lt Col, USAF
Director of Engineering

FOR THE COMMANDER

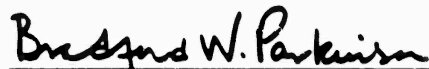

Bradford W. Parkinson, Colonel, USAF
Deputy for Space Navigation Systems

18 AIR FORCE REPORT NO. 3
SAMSQ-TR-75-251-VOL-3

14 STANFORD TELECOMMUNICATIONS, INC.
REPORT NO. STI-TR-10255-VOL-3

15 F04701-74-C-0310

9 Final rept. Mar 74-Oct 75,

6 **NAVSTAR GLOBAL POSITIONING SYSTEMS
SPECIAL STUDIES AND ENGINEERING PROGRAM.**

VOLUME III
FINAL REPORT
TASK II - DIRECT ACQUISITION STUDY.
TASK III - MANPACK STUDY.

ADD C

Prepared by:

10 James J. Spilker, Jr.,
Francis D. Natali
Jackson T. Witherspoon

11 25 October 1975

13 153p.

SPACE AND MISSILE SYSTEMS ORGANIZATION (AFSC)
LOS ANGELES AIR FORCE STATION
LOS ANGELES, CALIFORNIA

DISTRIBUTION STATEMENT B

Distribution limited to U.S. Government agencies only; Test and Evaluation; October 1975. Other requests for this document must be referred to SAMSQ (YEF).

STI STANFORD
TELECOMMUNICATIONS INC.

408804 ✓

B



15

FOREWORD

This document is Volume III of a four volume report. The four volume report is titled "NAVSTAR Global Positioning Systems Special Studies and Engineering Program". Volume III presents the results of two studies: One titled, "Direct Acquisition Study" previously submitted on 11 July 1975 at STI-TR 7115-2; the other titled "Manpack Study" previously submitted on 11 July 1975 as STI-TR 7115-3.

List of Figures

<u>Figure</u>		<u>Page</u>
1	Clock Synchronization	3-2
2	User Time Uncertainty	4-8
4	Acquisition Time for User with Low Velocity Uncertainty (≤ 5 MPH)	5-3
5	Acquisition Time for User with High Velocity Uncertainty (≤ 60 MPH)	5-4
Appendix B		
2	Probability of Detection	B-7
3	Probability of Detection	B-8
4	Probability of Detection	B-9
5	Probability of Detection	B-10
6	Probability of Detection	B-12
7	Probability of Detection	B-13
8	Probability of Detection	B-15
9	Probability of Detection	B-16

GPS SPECIAL STUDIES AND ENGINEERING PROGRAM
TASK II - DIRECT ACQUISITION STUDY

Table of Contents

<u>Section</u>		<u>Page</u>
1.0	INTRODUCTION	1-1
1.1	Conclusions and Recommendations	1-2
2.0	USER BASELINE AND PARAMETERS	2-1
2.1	Direct Acquisition Procedure	2-1
3.0	CLOCK SYNCHRONIZATION	3-1
4.0	SIGNAL ACQUISITION	4-1
4.1	Satellite Position Estimate	4-1
4.2	System Time Estimate	4-3
4.3	User Position Estimate	4-5
4.4	Satellite Clock Error	4-5
4.5	Ionospheric Delay	4-5
4.6	Time Uncertainty Summary	4-5
4.7	Carrier Frequency Estimate	4-9
4.8	Code Frequency Estimate	4-11
4.9	Clock Synchronization Summary	4-12
5.0	ACQUISITION TIMES FOR DIRECT P-SEQUENCE ACQUISITION	5-1
5.1	Acquisition Time	5-1
5.2	Acquisition of Additional Signals	5-5
5.3	Acquisition Time Conclusions	5-7
Appendix A		A-1
Appendix B		B-1

GPS SPECIAL STUDIES AND ENGINEERING PROGRAM
TASK III - MANPACK STUDY

Table of Contents

<u>Section</u>		<u>Page</u>
1.0	INTRODUCTION	1-1
1.1	Study Conclusion Summary	1-2
1.2	Study Recommendation Summary	1-4
2.0	MANPACK CONFIGURATION	2-1
2.1	Manpack Development Goals	2-1
2.2	Recommended User Classes	2-2
2.3	High Performance Manpack	2-4
2.4	Low-Cost Manpack	2-5
2.5	Comparison of HPM and LCM	2-9
2.6	Power Dissipation	2-11
2.7	Microminiaturization	2-12
2.8	Weight	2-13
2.9	Receiver Hardware	2-13
3.0	MICROPROCESSORS AND MICROCOMPUTERS	3-1
3.1	Introduction	3-1
3.2	Review of Present Microprocessor Technology	3-2
3.3	System Considerations in Microprocessor Selection	3-3
3.4	Software Support	3-5
3.5	Available Microcomputers	3-7
3.6	Microcomputer System Manufacturers	3-14
4.0	COMPUTER FUNCTIONS	3-17
4.1	Introduction	3-17
4.2	Receiver-Computer Interactions	3-17
4.3	User Position Determination	3-19

Table of Contents - cont'd

<u>Section</u>	<u>Page</u>
Biography	
Appendix A	A-1
Appendix B	B-1
Appendix C	C-1

List of Tables

<u>Table</u>		<u>Page</u>
1-2	Manpack Characteristics Summary	1-6
2-1	LCM Features	2-8
2-2	Summary of Sampling Requirements	2-19
3-1	Microcomputer Development Systems	3-13
3-2	Relative Speed and Memory Requirements	3-15
4-2	Number of arithmetic Operations for one Measurement Incorporation Step	3-21
4-3	Number of Arithmetic Operation for one Time Update Step	3-21
4-5	Computation Requirements for the Stationary User ($n=5$, $m=2$, $p=5$, $n_1=5$, $n_2=0$)	3-27
4-6	Computation Requirements for the Moving User I ($n = 8$, $m = 2$, $p = 8$, $n_1 = 8$, $n_2 = 0$)	3-28
4-7	Computation Requirements for the Moving User II ($n = 11$, $m = 2$, $p = 11$, $n_1 = 11$, $n_2 = 0$)	3-29
4-8	Program Variable Storage Requirements	3-32
4-9	Filter Variable Storage Requirements	3-32

List of Figures

<u>Figure</u>		<u>Page</u>
1	Manpack Set	2-3
2	Auxiliary Data Link to Reduce LCM Ionospheric Errors	2-7
3	Configuration for Comparing HPM and LCM Complexity Demod	2-10
4	Simplified Manpack Set Block Diagram	2-14
5	Example Carrier and Code Tracking Loop	2-15
6	Digital Implementation of Carrier and Code Tracking Loops	2-17
7	Example Implementation of a Four Channel Set	2-20
8	Speed in μ Sec	3-16

GPS SPECIAL STUDIES AND ENGINEERING PROGRAM

TASK II - DIRECT ACQUISITION STUDY

1.0 INTRODUCTION

The purpose of the direct acquisition is to determine the feasibility of a user acquiring a P signal directly (i.e. without the aid of the C/A signal) in the presence of jamming.

This investigation was approached in the following manner:

- (1) Determine direct acquisition performance based on presently anticipated system elements including the constellation selection program, satellite oscillators as specified, reasonable user oscillators, etc.
- (2) Conduct parametric investigations to determine requirements on critical system elements for acceptable direct acquisition performance.

This work was completed during August, 1974 and reported in STI memos GPS-008, 6PS-014, and GPS-018, from which this report is derived.

1.1 Conclusions and Recommendations

- The receiver local oscillator is the limiting factor in performing direct acquisition. A receiver local oscillator with overall stability of 10^{-9} or better appears to be required.
- The capability to remotely update the user clock in phase and frequency is required. This appears feasible.
- Direct acquisition appears feasible for the user with velocity uncertainty ≤ 5 MPH and with an oscillator which meets the requirements stated above. The low velocity uncertainty user employing a parallel receiver with oscillator stability $\leq 10^{-9}$ is expected to acquire all four signals within about 300 seconds with probability $\approx .9$ twenty-four hours after clock synchronization. Direct acquisition is considerably more difficult for the user with velocity uncertainty as great as 60 MPH. In this case, an oscillator with stability on the order of 10^{-10} is required if direct acquisition is to be practical twenty-four hours after clock synchronization.

Direct acquisition within 25 hours of an accurate clock update appears to be feasible for the manpack receiver. However, the oscillator requirements and addition receiver complexity composed are such that this mode of operation is not recommended for the manpack user equipment to be developed in the near future.

2.0 User Baseline and Parameters

Since the acquisition time results are dependent on both the assumed system and scenario, it is important that baselines be defined. It seems that direct acquisition would be desirable in two representative situations:

- (1) The user is not navigating and wishes to enter the system in the presence of jamming
- (2) The user is navigating but wishes to acquire a P signal in the presence of jamming due to satellite handover, momentary lost-of-lock, etc.

Obviously the user in the second situation has much more current and accurate system information than the user in the first situation and consequently a much less difficult reacquisition problem. The second situation will, for the moment, be considered as a special case of the first situation and not be discussed further at this time. We will treat the case where the user is not navigating but wishes to enter the system in the following material.

2.1 Direct Acquisition Procedure

The user does not know the exact code phase of the received signal and must therefore perform a code search by stepping the phase of the reference code with respect to the incoming code until correlation is achieved. This search process is relatively slow in the presence of jamming (<10 chips/sec for significant jamming levels), requiring that the initial code phase uncertainty be held to a minimum for reasonable acquisition times. For example, a 3000 chip uncertainty, corresponding to an uncertainty of $\pm 150 \mu s$ in code timing

searched at 10 chips/sec, would yield a maximum acquisition time of 300 sec. This time uncertainty probably represents an upper bound on what is acceptable. The user experiences uncertainty in code arrival time due to uncertainties in:

- system time
- satellite time
- satellite/user range
- ionospheric delay

It is obvious from the above discussion that the user must have a fairly accurate estimate of system time (probably with an error somewhat less than 150 μ s). Thus we may assume that the user will require a synchronized clock as well as some means for estimating satellite/user range.

Further, the code search may be carried out with only a relatively small uncertainty in carrier frequency (around 100 or 200 Hz). Larger uncertainties require parallel correlators or additional search time. Thus the user is required to estimate satellite/user doppler. The user also requires an accurate estimate of received code frequency (within 1 or 2 Hz) in order to achieve the desired code search rate. This estimate is derived along with the carrier frequency estimate.

The discussion that follows will assume the baseline:

- The user must incorporate a clock which requires synchronization
- Some time elapses between clock synchronization and the direct signal acquisition attempt

- The user employs his constellation selection program to estimate satellite/user range and range-rate
- The satellite clock performance is consistent with the present satellite specification
- The user employs a single noncoherent correlator with input bandwidth B_I .

3.0

CLOCK SYNCHRONIZATION

Two types of user clock synchronization may be considered. The first is "direct" synchronization from a local standard, such as a cesium beam clock located at an equipment depot, airport, on board ship, etc. The synchronization, in this case, is readily accomplished to within the accuracy of the local standard and requires very little complexity on the part of the user.

Unfortunately, direct synchronization at relatively frequent intervals may be inconvenient or impossible for many users.

The user, when navigating, may perform "remote" synchronization of his clock as follows:

- The user receives satellite time from the P signal data corresponding to code time ticks every 1.5 sec.
- Since the user knows his own position and the satellite orbit, he may compute propagation delay time.
- The user also receives satellite clock phase correction coefficients to allow calibration with system time.

Thus the navigating user may set his clock to within a few ns of correct system time using the signal from any satellite. Further, he may make a frequency correction by synchronizing with the received carrier, correcting for user/satellite doppler, and correcting for satellite clock frequency error (received on the P signal data). A block diagram of the clock synchronization is shown in Figure 1.

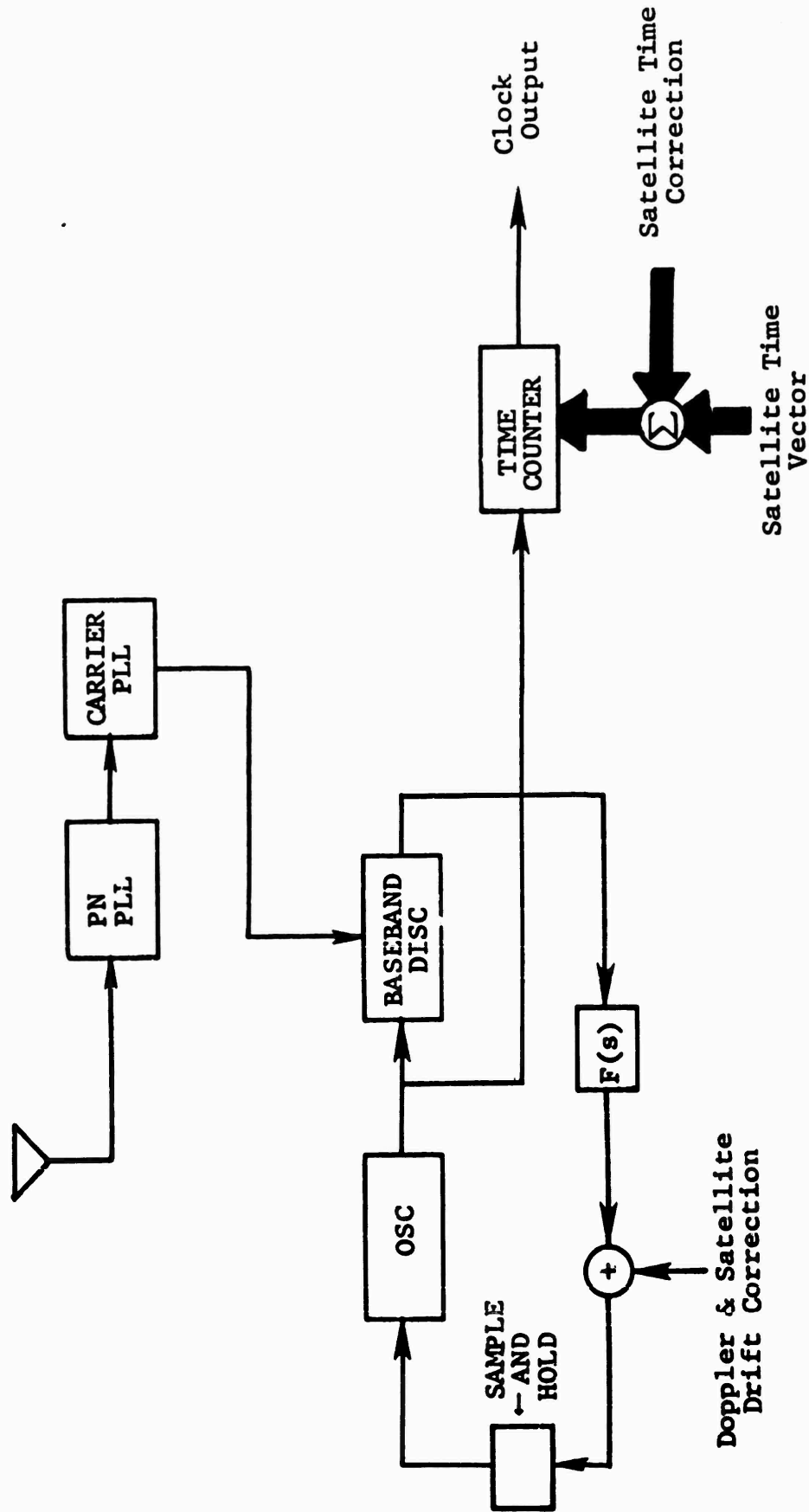

Figure 1 Clock Synchronization

The above synchronization procedure can actually be accomplished when only one satellite signal is being received, however the synchronization accuracy is degraded due to the uncertainty in user position and velocity.

In summary, remote synchronization when the user is navigating can be very accurate, with negligible error in phase, and frequency error limited primarily by the accuracy with which the user oscillator may be set.

4.0 SIGNAL ACQUISITION

Let us assume that after clock synchronization, the user receiver is turned off, except the clock, for some period of time and the user then attempts direct P signal acquisition. The user must first estimate received code phase based on estimates of

- system time
- satellite/user range.

The code phase estimate will be in error due to:

- error in satellite position estimate
- error in user position estimate
- error in user estimate of system time
- error in satellite clock with respect to system time
- ionospheric delay

These error sources are discussed below.

4.1 Satellite Position Estimate

Let us assume that the user relies on his initial orbit determination model for a satellite position estimate. The accuracy of such a model, employing the Kepler two-body equations, is discussed in Reference (1). The use of average values for orbit elements appears to be the best approach, since it gives a relatively stable value of maximum satellite position error for 12 to 16 days after element up-date. The in-track position error varies from about 40,000 feet to 70,000 feet over a sixteen day period. The change in satellite/user range due to in-track satellite position errors may be computed by employing the equations (Ref. (1)).

(1) R.E. Orr, TRW, DNSDP - RED-155

$$r^2 = r_e^2 + r_s^2 - 2r_e r_s \cos \alpha \quad (1)$$

$$\text{and } \Delta \alpha = \frac{\Delta P}{r_s} \quad (2)$$

where

r_s is the satellite geocentric radius, 87.2×10^6 ft

r_e is the earth's radius, 20.9×10^6 ft

r is the range from user to satellite

ΔP is the variation in satellite position along the direction of motion.

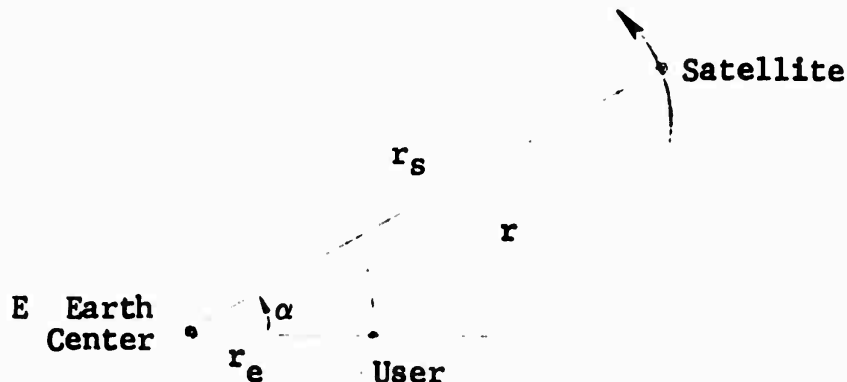

Differentiation Eq (1) with respect to α gives

$$\frac{dr}{d\alpha} = \frac{r_e r_s}{r} \sin \alpha$$

and substituting Eq (2) yields

$$\Delta R = \frac{r_e \Delta P}{r} \sin \alpha$$

Substituting numerical values,

$$\Delta R \approx .23 \Delta P \text{ when } \alpha = \pi/2$$

Thus we anticipate errors in the range estimate on the order of $\pm 14,000$ ft, based on an error of $\pm 60,000$ ft in the satellite position computation (i.e. a time uncertainty of $\pm 14 \mu\text{s}$).

4.2 System Time Estimate

The user clock will be in error due to

- initial time synchronization errors
- initial frequency synchronization errors
- user clock drift.

The initial time synchronization errors are expected to be negligible as discussed in Sec. 3.

An initial frequency synchronziation error may exist due to errors in the doppler and satellite oscillator correction, as well as an error in setting the oscillator. The doppler estimate and satellite frequency corrections should introduce a maximum combined error of about $\pm 2 \times 10^{-10}$, based on the requirement for range-rate accuracy of .06M/sec for the Class X and Y user (the Class Z user accuracy is not yet specified). An oscillator setting accuracy of $\pm 10^{-10}$ will be assumed (See Appendix A).

Once the user oscillator has been set, there will be frequency variations (for quartz crystal oscillators) generally categorized as being due to temperature variation, voltage variation, load variation, short term instability, and aging.

For the purpose of our investigation, let us assume that the user oscillator frequency is given by

$$f_u = f_o + \Delta f + \alpha t$$

where

f_o = nominal system standard frequency

Δf = a constant user frequency bias

α = frequency aging rate.

The frequency bias, Δf , will be considered to be a Gaussian random variable with standard deviation

$$\sigma_{\Delta f} = f_o \sqrt{\delta_T^2 + \delta_V^2 + \delta_L^2 + \delta_{STS}^2 + \delta_\epsilon^2}$$

where

δ_T = temperature stability

δ_V = voltage stability

δ_L = load stability

δ_{STS} = short term stability

δ_ϵ = setability

A discussion of parameters assumed for the above error sources is presented in Appendix A. Three baseline reference oscillators are considered for this investigation:

1. A low power crystal oscillator (LPO) with fast warmup and proportional oven temperature control for which $\frac{\sigma_{\Delta f}}{f_o} = 6 \times 10^{-9}$ and $\frac{\sigma \alpha}{f_o} = \pm 10^{-9}/\text{day}$.

2. An ultra stable crystal oscillator (USO), with a double proportional control oven, for which

$$\frac{\sigma_{\Delta f}}{f_0} = 1.4 \times 10^{-10} \text{ and } \frac{\sigma_a}{f_0} = \pm 10^{-10} / \text{day}.$$

3. An atomic standard (AS) with accuracy of 10^{-13} .

These baseline oscillators are discussed in more detail in Appendix A.

4.3 User Position Estimate

The error in the user position estimate will depend on individual circumstances. Position uncertainty, for present purposes, will be considered to be a circle with 5 n.mi radius, consistent with Table II of the User System Segment Specification, SS-US-101A. This will yield a worst case timing uncertainty of approximately $\pm 30 \mu\text{s}$.

4.4 Satellite Clock Error

The error in the satellite clock will be less than $\pm 10 \mu\text{s}$, according to present system specifications.

4.5 Ionospheric Delay

The ionospheric delay is a few chips at most and will therefore be neglected.

4.6 Time Uncertainty Summary

The anticipated time uncertainties are summarized in Table 1. There is some question as to how these time uncertainties should be combined to give the most meaningful results. For present

TABLE 1

ERROR SOURCE	ERROR (μs)	COMMENTS
Max Time Error due to Satellite Position Error	$\Delta T_{SP} = \pm 14 \mu s$ (max)	Orbit model computes satellite position to within $\pm 60,000$ ft
Max Error in Satellite Clock, T_{SC}	$\Delta T_{SC} = \pm 10 \mu s$ (max)	GPS Satellite specification (January 16, 1974)
1 σ Error in User Clock, σ_{UC}	$\sigma_T^2(LF9) = \left(6 \times 10^{-3} \frac{\mu s}{sec}\right)^2 + \left(10^{-8} \frac{\mu s}{sec}\right)^2$ $\sigma_T^2(USO) = \left(14 \times 10^{-5} \frac{\mu s}{sec}\right)^2 + \left(10^{-9} \frac{\mu s}{sec}\right)^2$	See Appendix A for user oscillator baseline definitions
Max Time Error, T_{UP} , due to User position uncertainty	$\sigma_T(AS) = 10^{-7} \frac{\mu s}{sec}$ $\Delta T_{UP} = \pm 30 \mu s$ (max)	GPS User Segment specification

purposes, let us assume that each error is a Gaussian random variable with 2σ value equal to the maximum value shown in Table 1 (with the exception of the user clock error). The total time uncertainty will also be considered to be Gaussian with standard deviation

$$\sigma_{\Delta T} = \sqrt{\left(\frac{\Delta r_{SP}}{2}\right)^2 + \left(\frac{\Delta r_{SC}}{2}\right)^2 + \left(\frac{\Delta r_{UP}}{2}\right)^2 + \sigma_T^2(UC)}$$

where $\sigma_T^2(UC)$ is the variance of the appropriate user clock.

Using the numerical values of Table 1, we have

$$\sigma_{\Delta T} = \sqrt{299 + \sigma_T^2(UC)}$$

This quantity is plotted vs time in Figure 2 for the different user oscillators.

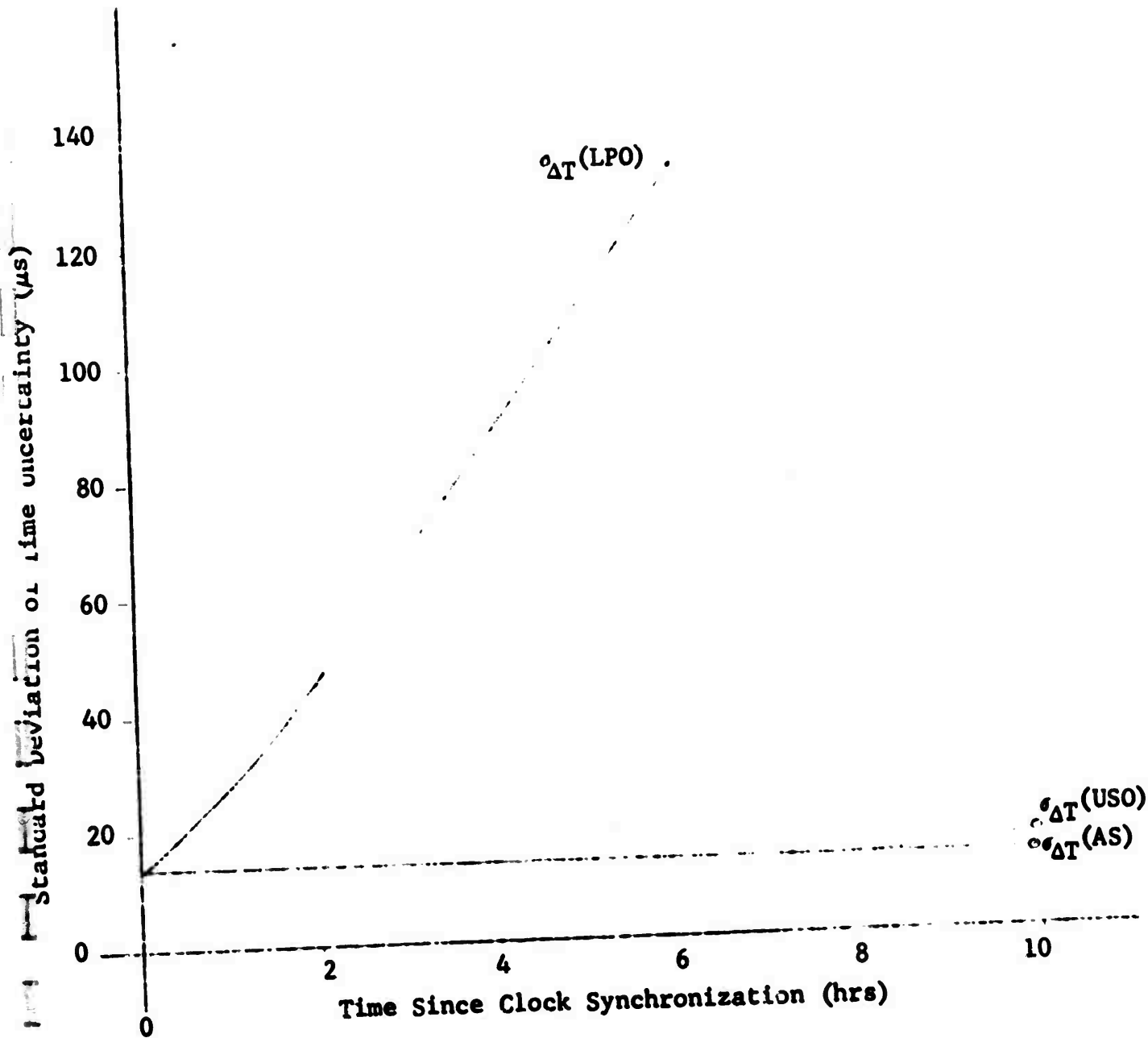

Figure 2 User Time Uncertainty

4.7 Carrier Frequency Estimate

The rate the user can search the received code timing uncertainty, depends partly on the accuracy with which the signal carrier frequency is known. The received carrier frequency may be off nominal due to satellite oscillator frequency offset and satellite/user doppler. Further, frequency error in the user oscillator will also appear as a signal offset. The problem of estimating signal carrier frequency is essentially the same as that encountered for C/A signal acquisition and is discussed in Reference (2). These estimates, presented in Reference (2), may be used when considering direct signal acquisition, except that the error due to the user oscillator is anticipated to be reduced by the synchronization process as described previously.

A summary of estimated frequency errors for the direct acquisition problem is shown in Table 2. These error sources will be handled in the same fashion as the time error sources, i.e. the errors will be assumed Gaussian with a 2σ value equal to the maximum value shown. The standard deviation of the frequency error will be expressed as

$$\sigma_f = \sqrt{\left(\frac{\Delta f_{SO}}{2}\right)^2 + \left(\frac{\Delta f_{SD}}{2}\right)^2 + \left(\frac{\Delta f_{UD}}{2}\right)^2} + \sigma_f(UC)$$

Using the values in Table 2 gives

$$\begin{aligned}\sigma_f &= \sqrt{6864 + \sigma_f^2(UC)} && \text{dynamic user} \\ &= \sqrt{464 + \sigma_f^2(UC)} && \text{stationary user}\end{aligned}$$

where $\sigma_f(UC)$ is the one sigma frequency error of the user clock.

(2) GPS Final Report, Part II, Philco-Ford, February 1974.

TABLE 2

ERROR SOURCE	FREQUENCY ERROR	COMMENTS
Satellite Oscillator	$\Delta f_{SO} = \pm 16 \text{ Hz (max)}$	Oscillator accuracy $\leq 10^{-8}$
Satellite Induced Doppler	$\Delta f_{SD} = \pm 40 \text{ Hz (max)}$	Maximum error of $\pm 25 \text{ fps}$ in computation of satellite velocity from keplarian orbit model.
User Induced Doppler	$\Delta f_{UD} = \pm 160 \text{ Hz (max)}$	Worst case for all user classes; corresponds to velocity uncertainty of 30 m/sec horizontal and 0 m/sec vertical.
User Oscillator Error	$\sigma_f(\text{LPO}) = 9.6 + 1.6 \times 10^{-4} t \text{ (Hz)}$ $\sigma_f(\text{USO}) = .22 + .16 \times 10^{-4} t \text{ (Hz)}$ $\sigma_f(\text{AS}) = 1.6 \times 10^{-4} \text{ (Hz)}$	See Appendix A.

The rate at which the user searches the received code may be controlled only to within the accuracy with which the received and nominal code rates are known, i.e. the user must reduce the nominal search rate below the desired maximum search rate by the amount of uncertainty in the code frequency estimate. The factors involved in estimating code frequency are the same as those discussed in connection with estimating carrier frequency. The accuracy of the code frequency estimate may be determined by multiplying the carrier frequency uncertainty by the ratio of the code to carrier frequencies, $\frac{1}{158}$. Thus we expect a maximum error in the code frequency estimate of about $\pm .5$ Hz.

4.9

Clock Synchronization Summary

- The user must have some means for synchronizing an internal clock. It is feasible to perform clock synchronization with negligible error during navigation.
- The user will have a 1σ timing error $\approx 17 \mu s$ (170 chips) in estimating receive code timing, assuming no user clock error.
- User induced doppler is a major source of frequency uncertainty.

5.0 ACQUISITION TIMES FOR DIRECT P-SEQUENCE ACQUISITION

Direct acquisition of the P-sequence by a non-navigating GPS user is discussed in some detail in the preceding sections.

The rate at which the received code, or time uncertainty, may be searched is derived in App. B with probability of detection (P_D) IF bandwidth (B_I), SNR_I , and probability of false alarm (P_{FA}) as parameters. The correlator detector in Figure 3 is assumed.

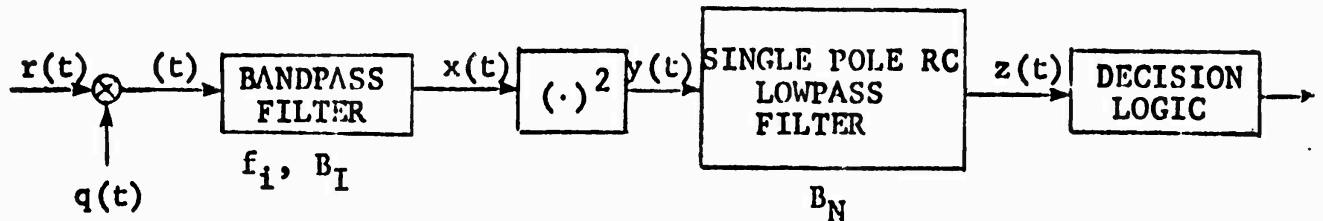

Figure 3 In-Lock Detector

5.1 Acquisition Time

The standard deviation of the received signal code time uncertainty is shown in Figure 2 vs time from clock synchronization for various user oscillator stabilities. Assuming that the time error is a Gaussian random variable, the search interval of $\pm 2\sigma_{\Delta T}$ will include the correct time position with probability .977.

The rate at which the code may be searched is plotted vs C/N_0 with B_I as a parameter, in Figure 4 for $P_D = .94$ and $P_{FA} = .005$. A correlator loss of 1 dB is assumed. The required IF bandwidth depends, of course, on the carrier frequency uncertainty (given by Eq. 2) and is taken to be $B_I \approx 4\sigma_f$ in the results that follow.

The time to acquire one signal may now be determined for a given C/N_0 (or J/S) by finding the corresponding search rate from Figure 3 where B_I is selected based on (Eq. 2), and the time interval to be searched is given by Eq. 1.

In the results that follow, we choose a time search interval of $\pm 2\sigma_{\Delta T}$, an IF bandwidth of $\pm 2\sigma_f$, and a $P_D = .94$. Thus the probability of acquiring the signal in a single pass is 0.9. The results plotted are maximum acquisition time, i.e. time to search the interval $- 2\sigma_{\Delta T}$ to $+ 2\sigma_{\Delta T}$ (the increase in acquisition time due to false alarms is assumed negligible). The optimum search pattern would start at the middle of the time uncertainty interval and spiral outward. However, it is considerably more straightforward to implement a search that starts at one end of the uncertainty interval and searches in one direction. In this case, the average acquisition is one-half of the maximum time.

Maximum acquisition time, $T_{acq}(\max)$, is shown vs time from clock synchronization in Figure 5 for a user with velocity uncertainty ≤ 5 MPH (corresponding to a large segment of the manpack population). Oscillator stability is seen to be the overriding factor in determining performance, with a stability of 10^{-9} or better being required for acceptable performance.

Similar curves are shown in Figure 6 for the user with a maximum uncorrected doppler of ± 160 Hz (corresponding to a velocity uncertainty of 30 m/sec horizontal and 6 m/sec vertical or 60 MPH. The search rate of 5 chips/sec is determined as follows. An IF bandwidth ≈ 350 Hz is required to accommodate the total frequency uncertainty. Interpolating between the curves of Figure 4 we find a maximum search rate of 7 chips/sec at $J/S = 45$ dB ($C/N_0 = 27$ dB-Hz). However, a code frequency uncertainty $\approx \pm 1$ chip/sec exists due to the same sources that cause an uncertainty in the carrier frequency.

47 0782

10 X 10 TO THE INCH 10 X 15 INCHES
K&E
KUPFFEL & ESSER CO. MADE IN U.S.A.

Figure 4 Acquisition Time for User with Low Velocity Uncertainty (≤ 5 MPH)

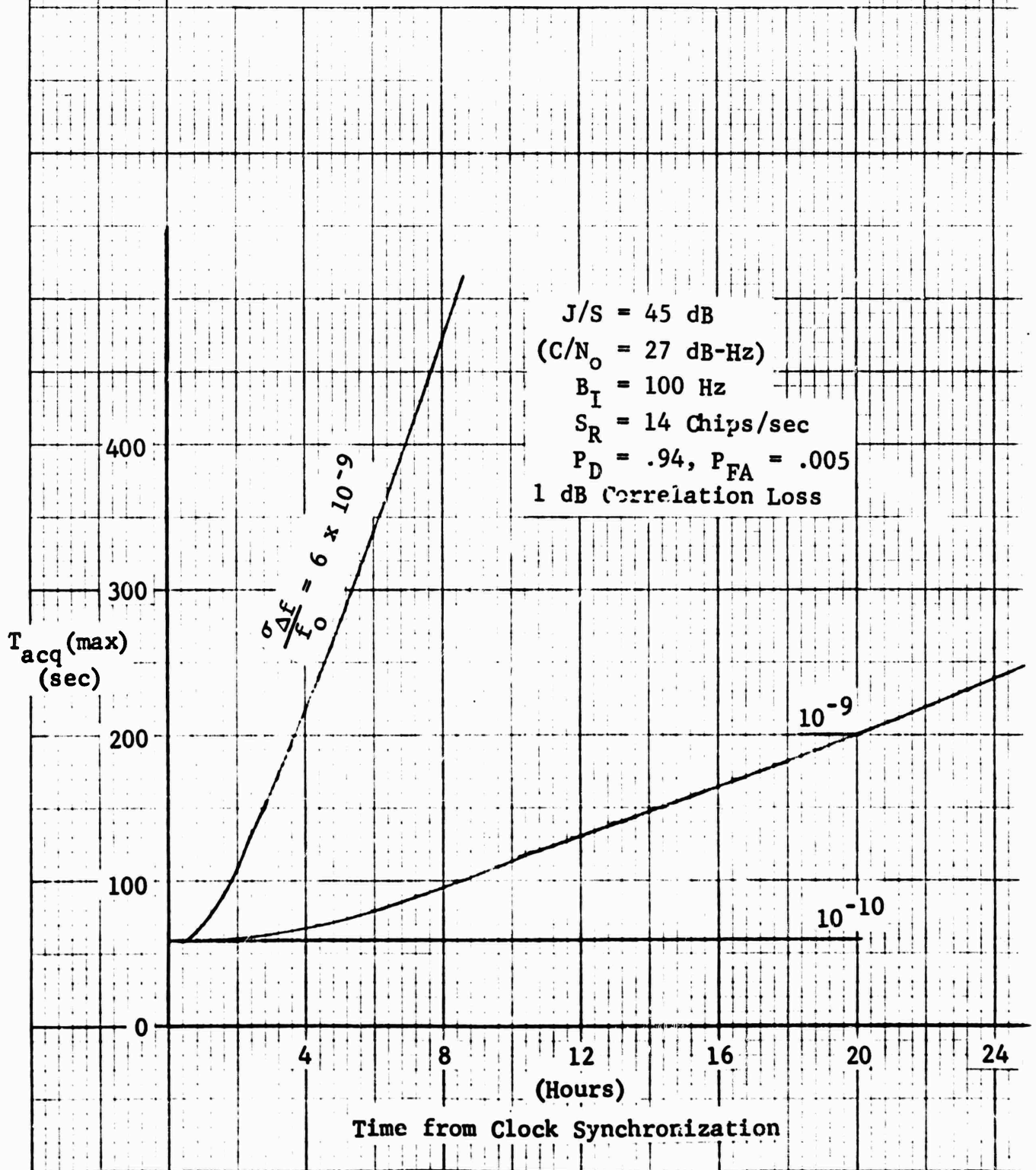
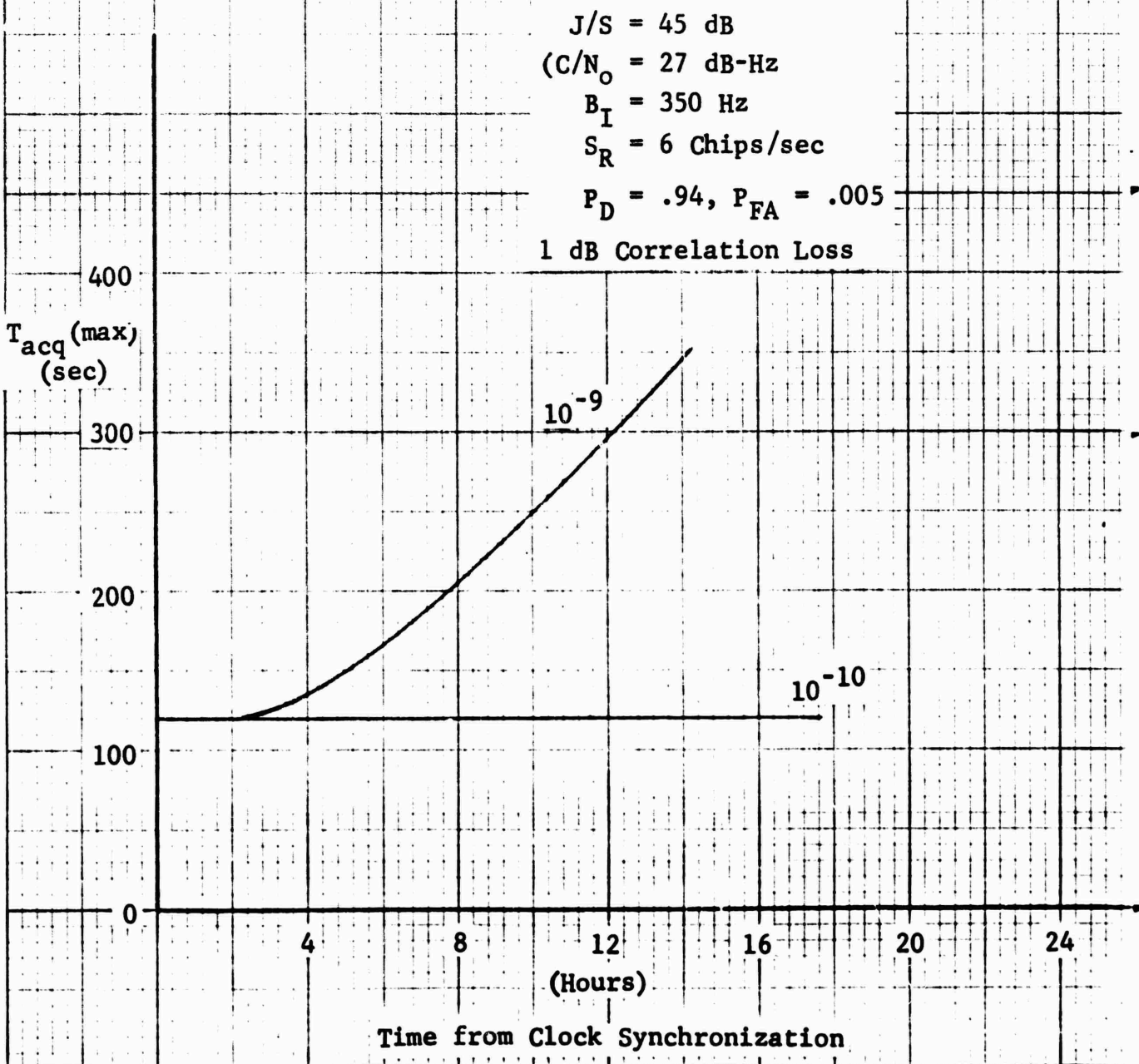

Figure 5 Acquisition Time for User with High Velocity Uncertainty (≤ 60 MPH)



Thus the nominal search rate is reduced to 6 chips/sec to ensure that the maximum search rate is not exceeded. The results indicate that relatively large uncorrected doppler causes a drastic increase in acquisition time (by a factor ≈ 2.8) and limits useful performance ($T_{acq} \leq 3$ min) to about five hours from clock synchronization for an oscillator with 10^{-9} stability.

5.2 Acquisition of Additional Signals

Certain user receivers may attempt to acquire four satellites in parallel, in which case the maximum time to acquire four satellites is the same as the maximum time to acquire one satellite (although the probability of acquiring all four on the first attempt is only about 0.65).

In case the receiver does not acquire all four signals (or if the user employs a sequential receiver) the acquisition of a single satellite signal allows the user to update his clock as discussed in Section 3. The other user may still experience a timing uncertainty $\sigma_{\Delta T} \approx 15 \mu s$, corresponding to 150 chips, due to position uncertainty (based on a maximum position uncertainty of ± 5 n mi). The clock update procedure may be expected to take a maximum of about 20 sec in order to collect a complete frame of data and make the necessary computations. The time to search the $4\sigma_{\Delta T}$ time uncertainty $\approx 60 \mu s$ will depend on the receiver in question, however a maximum search time of about 43 seconds would be required for the 14 chip/sec search rate quoted for the results of Figure 5.

No further search time is required if the receiver attempts to acquire the additional desired signals in parallel.

Thus the results of Figure 5 may be interpreted as follows. The parallel receiver will acquire at least one signal in $T_{acq}(\max)$ seconds with probability .999. Four signals may be acquired within $T_{acq}(\max) + 63$ seconds with probability $\approx .9$. In the case of the sequential receiver, the first signal is acquired within $T_{acq}(\max)$ with probability $\approx .9$. A maximum of about twenty seconds is then required to synchronize the clock, and a maximum of 43 seconds is required to acquire each additional signal (with probability $\approx .9$).

The results of Figure 6 may be interpreted in a similar manner except that about 100 seconds is required to acquire additional signals (due to the 6 chip/sec search rate).

In the interest of clarity, we will for the moment concern ourselves only with the parallel receiver which acquires with probability $\approx .9$ in $T_{acq}(\max) + 63$ seconds for the user with velocity uncertainty ≤ 5 MPH and in $T_{acq}(\max) + 120$ seconds for the user with velocity uncertainty ≤ 60 MPH.

5.3 Acquisition Time Conclusions

Our conclusions may be summarized as follows:

- The receiver local oscillator is the limiting factor in performing direct acquisition.

Direct acquisition appears feasible for the user with velocity uncertainty ≤ 5 MPH and with a receiver local with overall stability $\leq 10^{-9}$. Direct acquisition is considerably more difficult for the user with velocity uncertainty as great as 60 MPH. In this case, an oscillator with stability on the order of 10^{-10} is required if direct acquisition is to be practical twenty-four hours after clock synchronization.

- A parallel receiver significantly reduces the time required to acquire four signals.
- The low velocity uncertainty user employing a parallel receiver with oscillator stability $\leq 10^{-9}$ is expected to acquire all four signals within about 300 seconds with probability $\approx .9$ twenty-four hours after clock synchronization.

APPENDIX A

USER OSCILLATORS

The characteristics of the user local oscillator are an important factor in the ability to perform direct acquisition. The quality of the user oscillator will probably vary with intended application since better performance generally implies increased size, weight and power consumption. For the purposes of this investigation, three representative oscillator baselines will be considered:

1. A low power, fast warmup, proportional temperature control, crystal oscillator
2. A high quality, double proportional control, crystal oscillator
3. An atomic standard with 10^{-13} accuracy (based on the User Segment direct acquisition specification, Paragraph 3.2.1.6 and Table II).

A.1 Low Power Oscillator (LPO) Characteristics

An Army sponsored program to prove feasibility of a low power, fast warmup, microcircuit crystal reference oscillator was conducted by Bendix Corporation and is reported in Reference (3). Five test oscillators were built under this program with varying degrees of success. This program gives an indication of what one may expect in terms of oscillator characteristics for a user that requires direct acquisition, but where size, weight, and power consumption must be minimized. The program goals and best results achieved are summarized in Table A-1. Characteristics of a commercially available oscillator of conventional design, employing a proportional control oven, are also included for comparison. A baseline oscillator has been assumed with characteristics also shown in Table A-1. The baseline in most

(3) H.M. Greenhouse, et al, "Fast Warmup Quartz Reference Oscillator, Final Report," ECOM-0265-F, Bendix Communications Div., June 1973.

TABLE A-1

	GOAL	BEST PERFORMANCE ACHIEVED	VECTRON C-204	BASELINE
Size	1 cu. in	.95 cu. in	12 cu. in	1 cu. in
Warmup Power	10 ^w	6.84 ^w	5 ^w	6 ^w
Operating Power	250 mw	273 mw	2.5 ^w	250 mw
Short Term Stability	10 ⁻¹¹ , 1 sec ≤ ΔT _{ave} ≤ 20 min	± 2.5 x 10 ⁻¹⁰	< ± 10 ⁻¹⁰ /sec	< ± 2 x 10 ⁻¹⁰ ΔT = ≤ 20 min
Frequency Aging	< ± 2 x 10 ⁻¹⁰ /wk	7 x 10 ⁻⁹ /wk	< ± 10 ⁻⁹ /day	< ± 10 ⁻⁹ /day
Temperature Stability	< ± 10 ⁻⁸ , -40°C to 75°C	< ± 4 x 10 ⁻⁹	< ± 10 ⁻⁸ -20°C to + 70°C	< ± 4 x 10 ⁻⁹
Voltage Stability	< ± 10 ⁻⁹ , ΔV = + 5%	< ± 6 x 10 ⁻¹⁰	< ± 2 x 10 ⁻⁹ , ΔV = + 5%	< ± 10 ⁻⁹
Load Stability	< ± 10 ⁻⁹ , ΔR = ± 10%	< ± 8.6 x 10 ⁻⁹	< ± 10 ⁻⁹ , ΔR = ± 10%	< ± 10 ⁻⁹
Warmup Time	≤ 1 min to within ± 3 x 10 ⁻⁸	110 sec		
Frequency Adjustment	> ± 5 x 10 ⁻⁸	4.4 x 10 ⁻⁷	≥ 3 x 10 ⁻⁷	> 10 ⁻⁷
Setability		± 2 x 10 ⁻¹⁰		± 10 ⁻¹⁰
Frequency Recovery	< ± 3 x 10 ⁻⁹ at 40°C	1.2 x 10 ⁻⁸		< ± 10 ⁻⁸

instances assumes that performance will be at least as good as the conventional oscillator, and that the best performance achieved during the feasibility program will be repeated on a mass production basis in the future.

For the purposes of our investigation, let us assume that the user oscillator frequency is given by

$$f_u = f_o + \Delta f + \alpha t$$

where

f_o = nominal system standard frequency (Hz)

Δf = a constant user frequency bias (Hz)

α = frequency aging rate ($\frac{\text{Hz}}{\text{sec}}$).

The frequency bias, Δf , will be considered to be a Gaussian random variable with standard deviation

$$\sigma_{\Delta f} = f_o \sqrt{\delta_T^2 + \delta_V^2 + \delta_L^2 + \delta_{STS}^2 + \delta_\epsilon^2}$$

where

δ_T = temperature stability

δ_V = voltage stability

δ_L = load stability

δ_{STS} = short term stability

δ_ϵ = setability

Substituting the parameters assumed for the baseline oscillator:

$$\begin{aligned}\frac{\sigma_{\Delta f}}{f_0} &= \sqrt{(4 \times 10^{-9})^2 + (10^{-9})^2 + (10^{-9})^2 + (2 \times 10^{-10})^2 + (10^{-10})^2} \\ &= 6 \times 10^{-9}\end{aligned}$$

Similarly, α will be considered a g.r.v. with 1σ value equal to the aging rate.

The baseline low power oscillator (LPO) is thus characterised by:

$$\frac{\sigma_{\Delta f}}{f_0} = 6 \times 10^{-9}$$

$$\frac{\sigma_{\alpha}}{f_0} = \pm 10^{-9}/\text{day}.$$

A.2 Ultra-Stable Crystal Oscillator (USO) Performance

The temperature stability of a crystal oscillator can be improved by approximately an order of magnitude, at the cost of increased size and power consumption, if a double proportional controlled oven is employed. The characteristics of a representative, commercially available, ultra-high stability oscillator are shown in Table A-2. These stability characteristics will be assumed as a baseline for a sophisticated user who does not have an atomic clock.

TABLE A-2

	Vectron Co-243 Baseline #2
Size	4" x 4" x 9"
Warmup Power	12 ^w
Operating Power	6 ^w
Short Term Stability	< 10 ⁻¹¹ /sec
Frequency Aging	< 10 ⁻¹⁰ /day
Temperature Stability	± 10 ⁻¹⁰ 0°C to 50°C
Voltage Stability, ΔV = 5%	± 2 x 10 ⁻¹¹
Load Stability, ΔR = 10%	± 10 ⁻¹¹
Frequency Adjustment	10 ⁻⁷
Setability	10 ⁻¹⁰
Frequency Recovery	< 2 x 10 ⁻⁹

Using the equations of Section A.1, the baseline ultra-stable crystal oscillator is characterized by

$$\frac{\sigma_{\Delta f}}{f_0} = 1.4 \times 10^{-10}$$

$$\frac{\sigma_{\alpha}}{f_0} = \pm 10^{-10}/\text{day}$$

APPENDIX B

DIRECT ACQUISITION CODE SEARCH PERFORMANCE

B.1 INTRODUCTION

Direct acquisition of the P component of the L1 signal is being considered as a means for improving the ability of the GPS user to operate in a jamming environment. The technique for acquiring the P code is to step a correlator in 1/2 chip increments over the region of received code phase uncertainty until correlation is detected. This note presents analytical results which indicate how fast the code can be searched for a given set of performance and signal parameters for the non-coherent correlator of Figure B-1. This "in-lock" detector, while not necessarily optimum, provides good performance consistent with a minimum of complexity.

The IF bandpass filter in the figure is centered at the nominal frequency of the input signal, and has a bandwidth wide enough to cover the frequency uncertainty of the input. The output of the IF filter is fed through a square-law device whose output is further filtered through the lowpass filter. The lowpass filter output becomes the decision variable based on which the code acquisition is to be determined. That is "in-lock" is pronounced when the decision variable exceeds a certain threshold level; otherwise code search is continued.

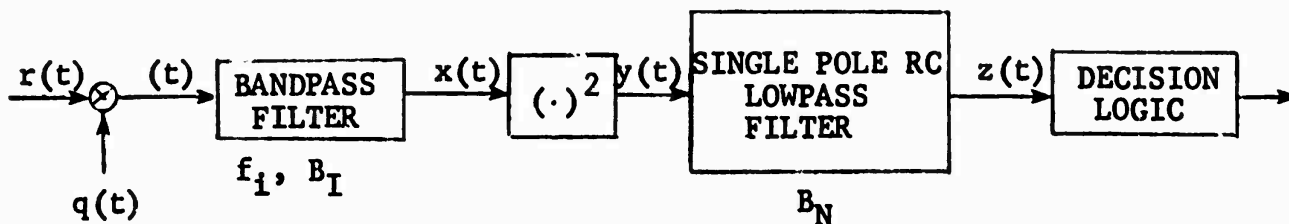

Figure B-1 An In-Lock Detector

B.2 ANALYSIS

Referring to Figure B-1, let the input signal and the local oscillator output be

$$\begin{aligned}r(t) &= \sqrt{2P} s(t) \cos (\omega_0 t + \varphi) + \eta_1(t) \cos (\omega_0 t + \varphi) \\ &\quad - \eta_2(t) \sin (\omega_0 t + \varphi) \\ q(t) &= \sqrt{2} s(t + \epsilon) \cos \omega_c t\end{aligned}$$

where

$s(t)$ = pseudonoise (PN) code waveform = ± 1

$s(t + \epsilon)$ = locally regenerated PN code waveform with timing error of $|\epsilon| < \Delta$, Δ being the PN code chip time interval,

$\eta_1(t), \eta_2(t)$ = two independent white Gaussian random processes with power spectral density of N_0 watt/Hz.

φ = Uniformly distributed random variable over the range of 0 to 2π radians.

The output of the multiplier is given by

$$\begin{aligned}v(t) &= \sqrt{P} s(t)s(t + \epsilon) \cos (\omega_1 t - \varphi) \\ &\quad + \frac{1}{\sqrt{2}} s(t + \epsilon)\eta_1(t) \cos (\omega_1 t - \varphi) \\ &\quad + \frac{1}{\sqrt{2}} s(t + \epsilon)\eta_2(t) \sin (\omega_1 t - \varphi)\end{aligned}$$

where $\omega_i = \omega_c - \omega_0$. In the above equation we have ignored terms involving $(\omega_0 + \omega_c)$ because they fell outside of the IF filter passband. The output of the IF filter whose bandwidth is very much smaller than the PN code chip rate, is

$$x(t) = \left\{ \begin{aligned} &\sqrt{P} \left(1 - \frac{|\epsilon|}{\Delta} \right) \cos(\omega_i t - \varphi) + \eta_1'(t) \cos(\omega_i t - \varphi) \\ &+ \eta_2'(t) \sin(\omega_c t - \varphi) \end{aligned} \right.$$

when ω_i falls inside the IF filter passband

$$\eta_1'(t) \cos(\omega_i t - \varphi) + \eta_2'(t) \sin(\omega_i t - \varphi)$$

when ω_i falls outside the IF filter passband

$\eta_1'(t)$ and $\eta_2'(t)$ are independent Gaussian random processes with power spectral density of $\frac{N_0}{2}$ watt/Hz.

The lowpass component of the square law device output is

$$y(t) = x^2(t) |_{\text{lowpass}} = \left\{ \begin{aligned} &\frac{P}{2} \left(1 - \frac{|\epsilon|}{\Delta} \right)^2 + \frac{\eta_1'^2(t) + \eta_2'^2(t)}{2} \\ &+ \sqrt{P} \left(1 - \frac{|\epsilon|}{\Delta} \right) \eta_1'(t) \end{aligned} \right.$$

when ω_i falls within the IF filter passband

$$\frac{\eta_1'^2(t) + \eta_2'^2(t)}{2} \text{ when } \omega_i \text{ falls out-}$$

side the IF filter passband.

The probability density of $y(t)$ is either a Rician or a Rayleigh, depending on whether the signal frequency ω_i falls within the IF filter passband. The power spectral density of $y(t)$ near zero frequency is

$$S_y(f) = \begin{cases} \left(\frac{P}{2} + \frac{N_0 B_I}{2} \right) \delta(f) + \left(P + \frac{N_0}{2} B_I \right) \frac{N_0}{2} & \text{when } \omega_i \text{ falls} \\ & \text{within the IF filter passband} \\ \left(\frac{N_0 B_I}{2} \right) \delta(f) + \left(\frac{N_0}{2} \right)^2 B_I & \text{when } \omega_i \text{ falls} \\ & \text{outside the IF filter passband} \end{cases} \quad (1)$$

where B_I = IF filter bandwidth in Hz. (2)

The decision variable $z(t)$ is given by

$$z(t) = y(t) * h_f(t)$$

where $h_f(t)$ is the impulse response of the filter and "*" stands for convolution. The probability density function of z is not readily computed because $y(t)$ is a non-Gaussian process. However, if the bandwidth of the lowpass filter, B_L is much smaller than that of the IF filter, one can invoke the central limit theorem to conclude that $z(t)$ can be approximated by a Gaussian distribution. That is, assuming $\epsilon = 0$

$$p_z(u) = \frac{1}{\sqrt{2\pi}\sigma_z} \exp - \left[\frac{1}{2\sigma_z^2} (u - m_z)^2 \right]$$

where

$$m = \begin{cases} \frac{P}{2} + \frac{N_o B_I}{2} & \text{when } \omega_i \text{ falls within the IF filter passband} \\ \frac{N_o B_I}{2} & \text{when } \omega_i \text{ falls outside the IF filter passband} \end{cases} \quad (3)$$

$$\sigma_z^2 = \begin{cases} \left(P + \frac{N_o}{2} B_I \right) \frac{N_o}{2} B_N & \text{when } \omega_i \text{ falls within the IF filter passband} \\ \left(\frac{N_o}{2} \right)^2 B_I B_N & \text{when } \omega_i \text{ falls outside the IF filter passband} \end{cases} \quad (4)$$

$$\begin{array}{l} B_N = \text{two-sided noise bandwidth of the lowpass filter} \\ \text{in Hz} \end{array} \quad (5)$$

We are now ready to compute the probabilities of false alarm and false dismissal, i.e. probabilities of a mistaken "in-lock" when in fact code is not acquired and of a mistaken "out-of-lock" when code is acquired. Letting the normalized threshold setting of the threshold detector be

$$T = t / \frac{P}{2}$$

where t being actual threshold setting in volts, then it can be shown that

$$\begin{aligned} P_d &= \text{probability of false dismissal} = \text{Prob} (z < t \mid \text{signal present}) \\ &= \frac{1}{2} \left\{ 1 - \text{erf} \left[\frac{1 + \frac{1}{\text{SNR}} - T}{\sqrt{\left(2 + \frac{1}{\text{SNR}}\right) \frac{2}{\text{SNR}} \cdot \frac{B_N}{B_I}}} \right] \right\} = \frac{1}{2} \text{erfc} \left[\frac{1 + \frac{1}{\text{SNR}} - T}{\sqrt{\left(2 + \frac{1}{\text{SNR}}\right) \frac{2}{\text{SNR}} \cdot \frac{B_N}{B_I}}} \right] \end{aligned} \quad (7)$$

P_a = probability of false alarm = Prob($z > t$ | signal not present)

$$= \frac{1}{2} \operatorname{erfc} \left[\frac{T - \frac{1}{\operatorname{SNR}}}{\sqrt{\frac{2B_N}{B_I} \frac{1}{\operatorname{SNR}}}} \right] \quad (8)$$

where

$$\operatorname{SNR} = \frac{P}{N_o B_I} = \text{signal-to-noise ratio at the IF filter output.} \quad (9)$$

$P_D = (1 - P_d)$ and P_a have been computed numerically vs SNR for fixed values of B_N/B_I and are shown in Figures B-2 through B-5.

In the analysis presented above it has been assumed that a steady-state condition has existed in the system prior to the sampling of the decision variable, $z(t)$, and a decision made. That is, the dwell time T_D per code chip is at least several times longer than the time constant, T_C , of the RC lowpass filter, such that the signal component has built up to its steady-state value at the filter output. However, for the problem at hand we are most interested in minimizing the dwell time with constraints on the values of P_a , P_d , B_N/B_I , and SNR. Therefore, we have to extend our analysis to include the case where the system is in a transient state. Again, assuming $B_N/B_I \ll 1$ such that the variable $z(t)$ has a Gaussian distribution, the mean value and variance of z under transient conditions can be shown to be

(SNR) IF dB

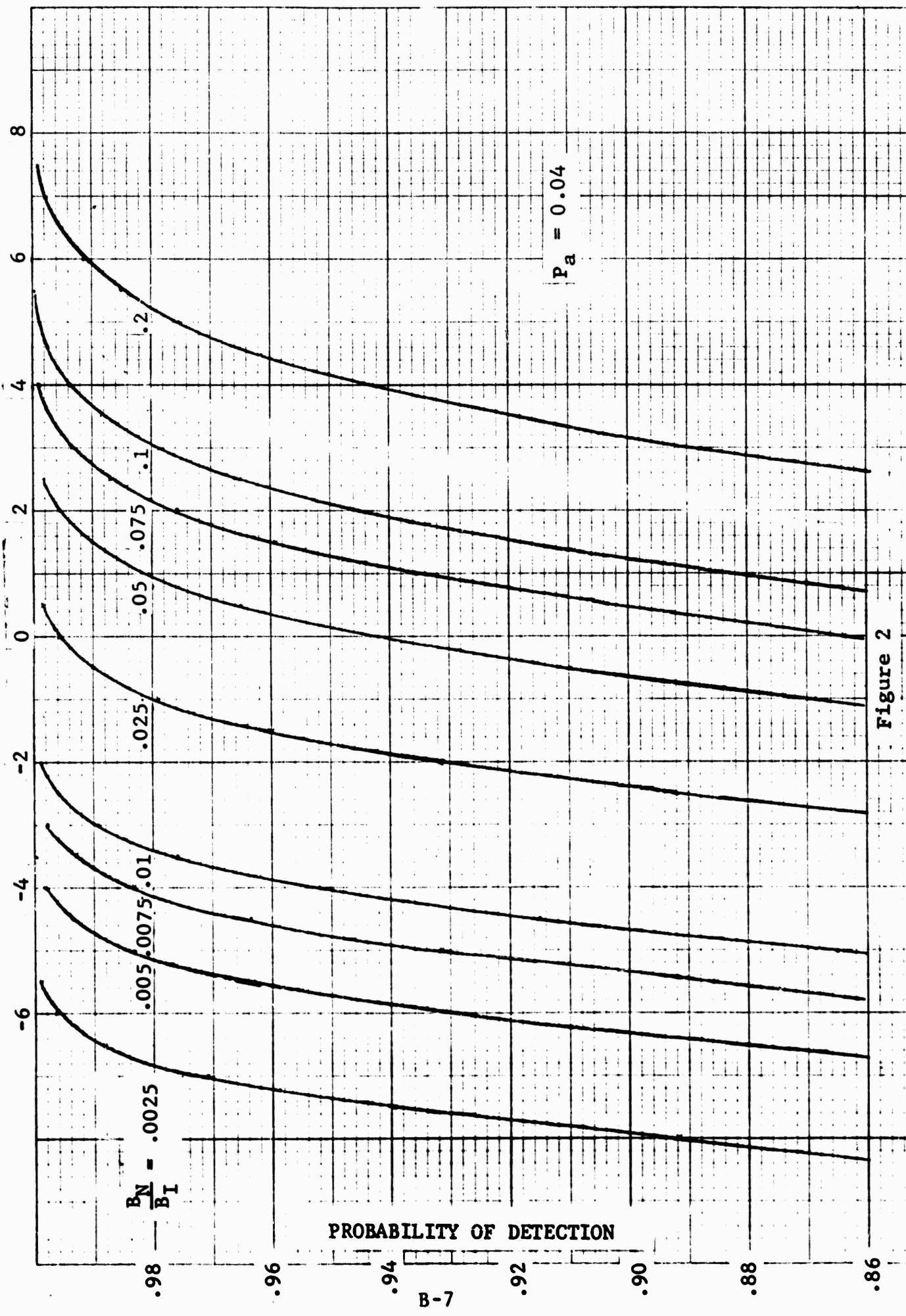

Figure 2

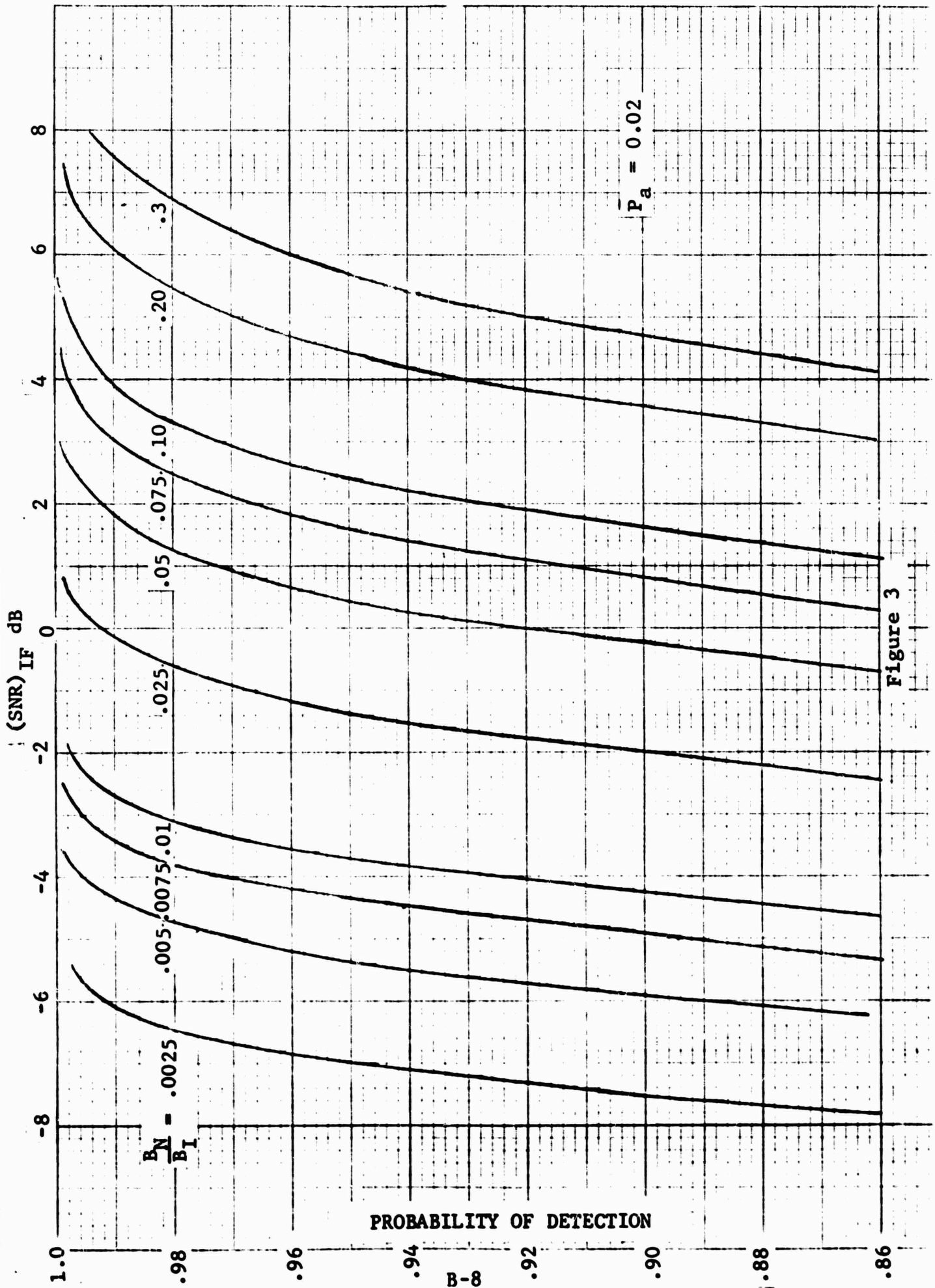

Figure 3

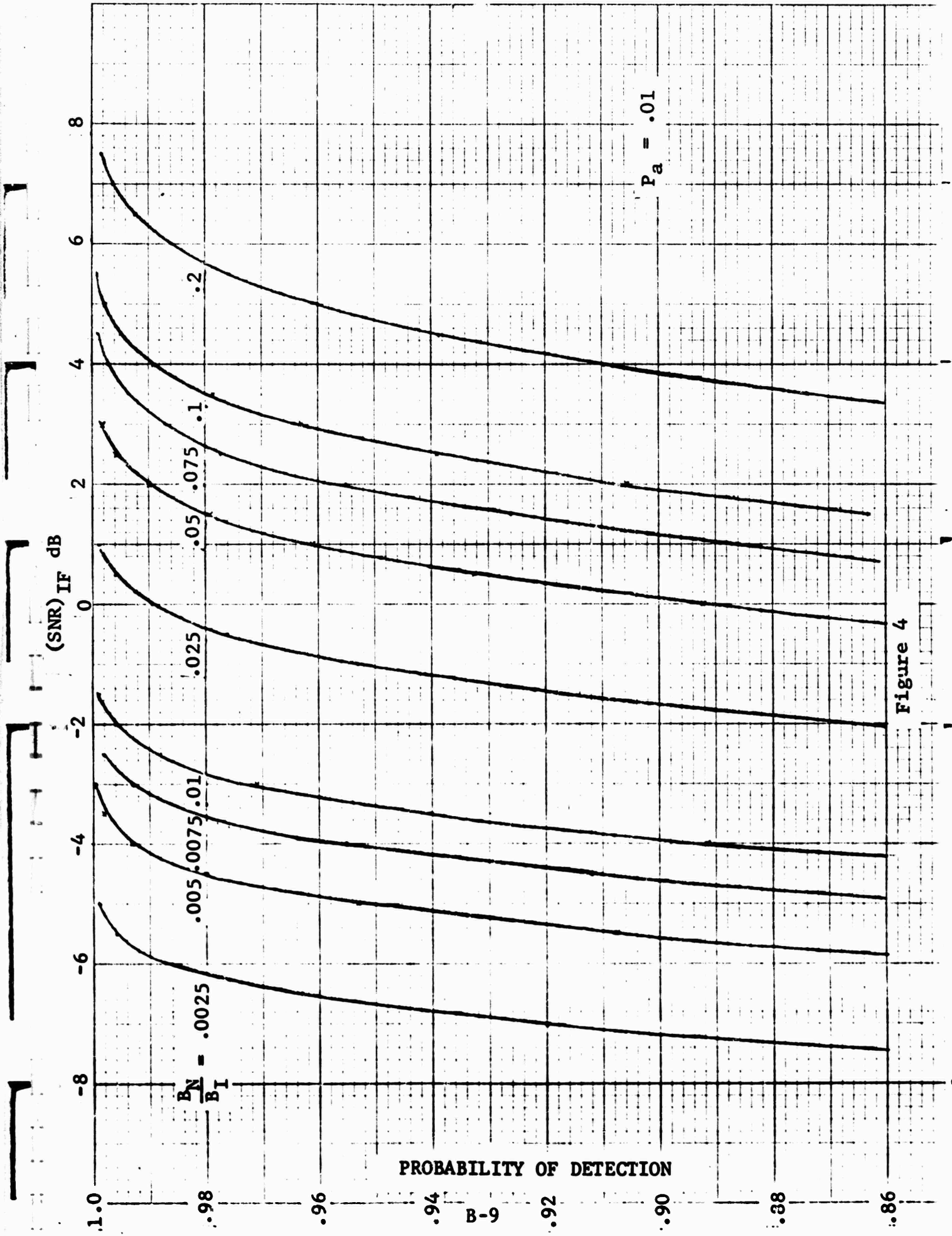

Figure 4

B-9

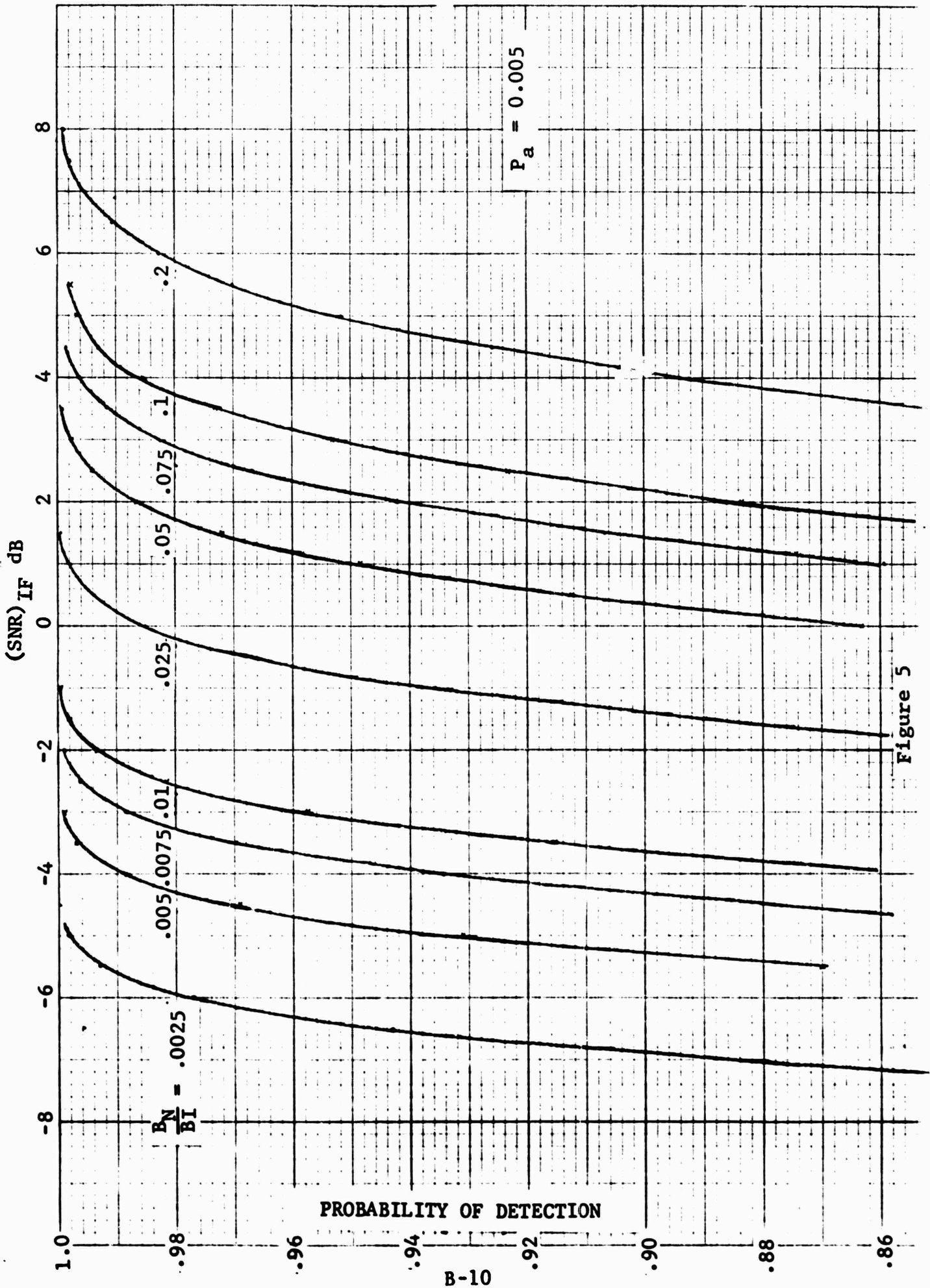

Figure 5

$$M_z' = \begin{cases} \left(\frac{P}{2} (1 - e^{-T_D/T_C}) + \frac{N_0 B_I}{2} \right) & \text{when } \omega_i \text{ falls within the} \\ & \text{IF filter passband} \\ \frac{N_0 B_I}{2} & \text{when } \omega_i \text{ falls outside the} \\ & \text{IF filter passband} \end{cases} \quad (10)$$

$$\sigma_z'^2 = \begin{cases} \left[P (1 - e^{-2T_D/T_C}) + \frac{N_0 B_I}{2} \right] \frac{N_0 B_N}{2} & \text{when } \omega_i \text{ falls within} \\ & \text{the IF filter passband} \\ \left(\frac{N_0}{2} \right)^2 B_I B_N & \text{when } \omega_i \text{ falls outside the} \\ & \text{IF filter passband} \end{cases} \quad (11)$$

The respective probabilities of false dismissal and false alarm are

$$P_d = \frac{1}{2} \operatorname{erfc} \left\{ \frac{1 - e^{-T_D/T_C} + \frac{1}{\operatorname{SNR}} - T}{\sqrt{\left[2(1 - e^{-2T_D/T_C}) + \frac{1}{\operatorname{SNR}} \right] \frac{2}{\operatorname{SNR}} \cdot \frac{B_N}{B_I}}} \right\} \quad (12)$$

$$P_a = \frac{1}{2} \operatorname{erfc} \left[\frac{T - \frac{1}{\operatorname{SNR}}}{\sqrt{\frac{2B_N}{B_I} \frac{1}{\operatorname{SNR}}}} \right] \quad (13)$$

where T_C = time constant of the RC lowpass filter = $\frac{1}{2B_N}$.

Figures B-6 and B-7 shows $(1 - P_d)$ vs T_D/T_C with SNR and B_I as

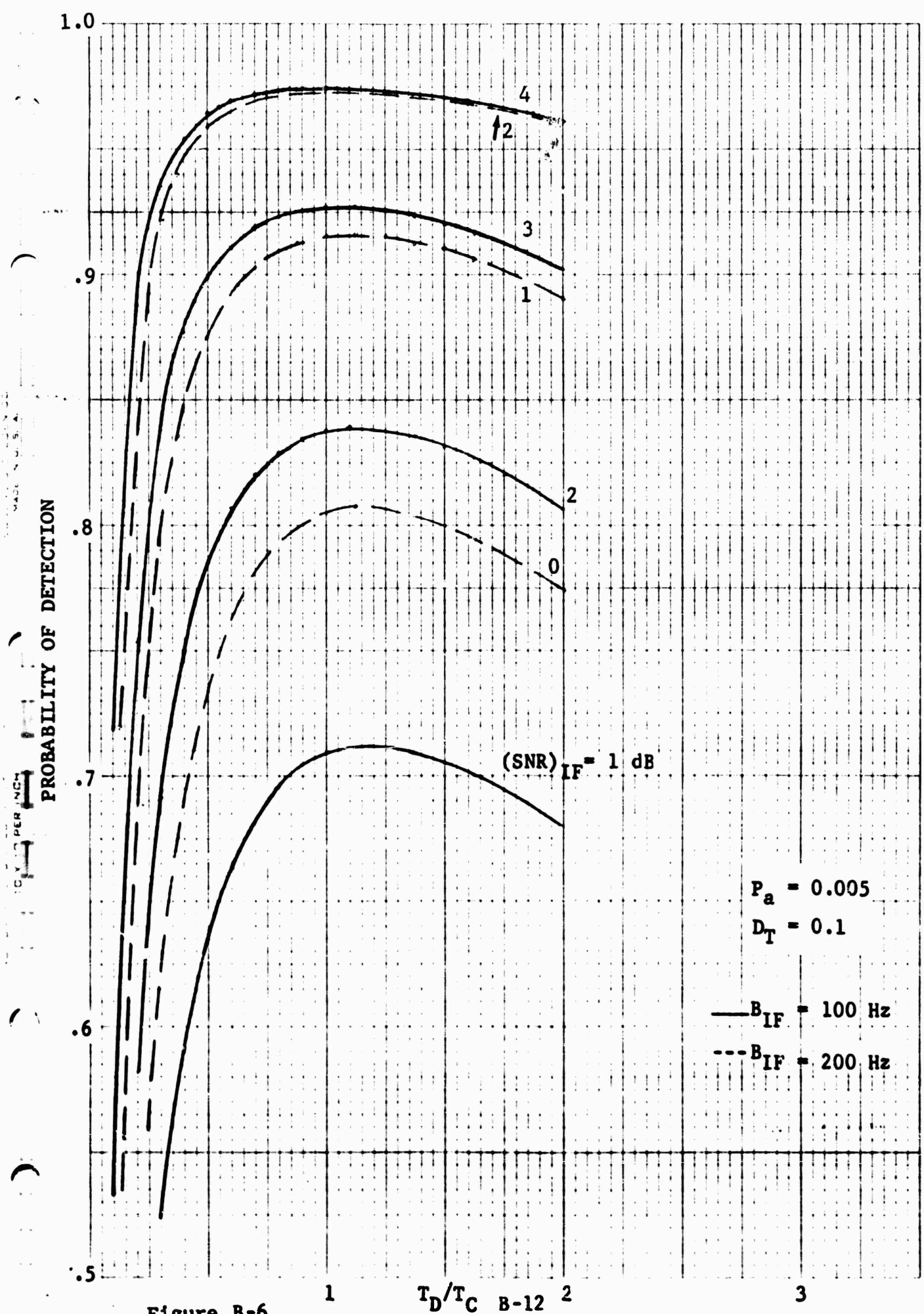

Figure B-6

10 x 17 1/2 INCH
PROBILLY OF DETECTION
MADE IN U.S.A.

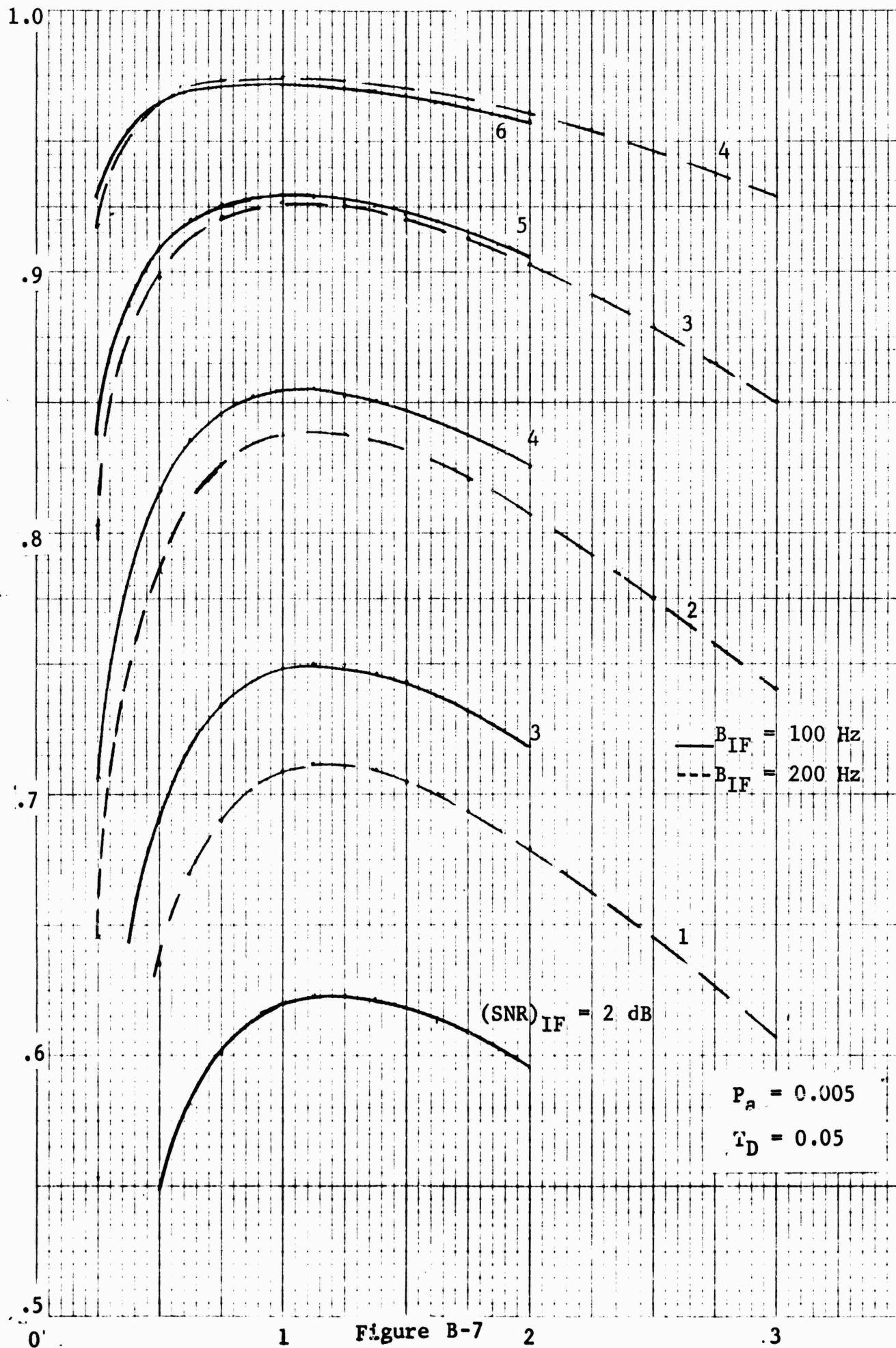
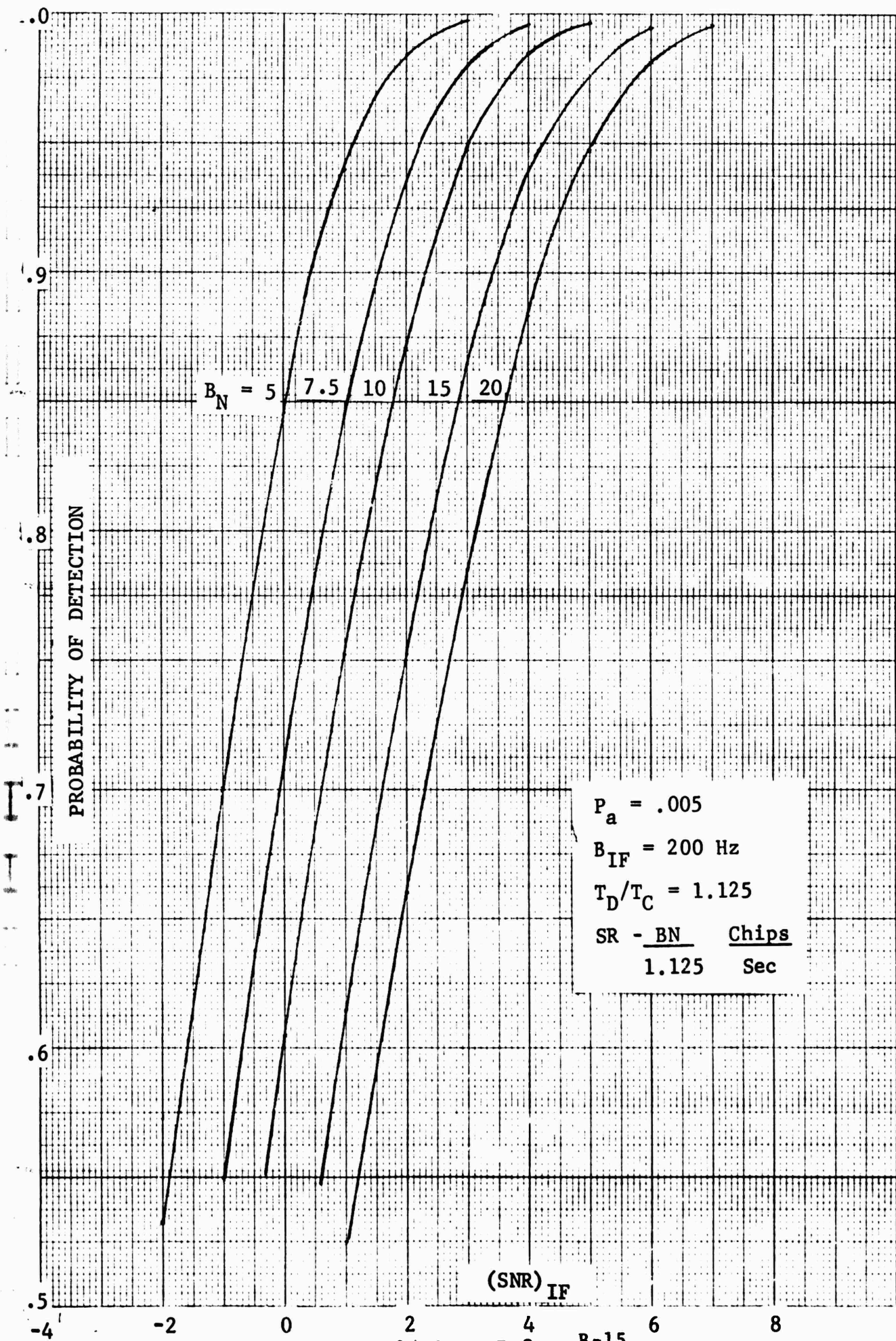

Figure B-7

parameters. In both figures, P_a is assumed to be 0.005 and $T_D = 0.1$ and 0.05 , respectively. It is seen that the optimum value of T_D/T_C is 1.25 for low SNR and is about 1.1 for values of SNR such that $P_D = (1 - P_d)$ is equal to or greater than 0.9. That is, for maximum probability of detection, P_D , the dwell time should be 1.1 times the time constant of the lowpass filter. Figures B-8 and B-9 shows P_D vs (SNR) for $B_I = 200$ Hz and 100 Hz, respectively. In these figures P_a is equal to .005 and $T_D/T_C = 2 B_I T_D$ is set at 1.125.



PROBABILITY OF DETECTION

$B_N = 5 \quad 7.5 \quad 10 \quad 15 \quad 20$

$P_a = .005$
 $B_{IF} = 200 \text{ Hz}$
 $T_D/T_C = 1.125$
 SR - $\frac{B_N}{1.125}$ Chips
 1.125 Sec

(SNR) IF

Figure B-8

B-15

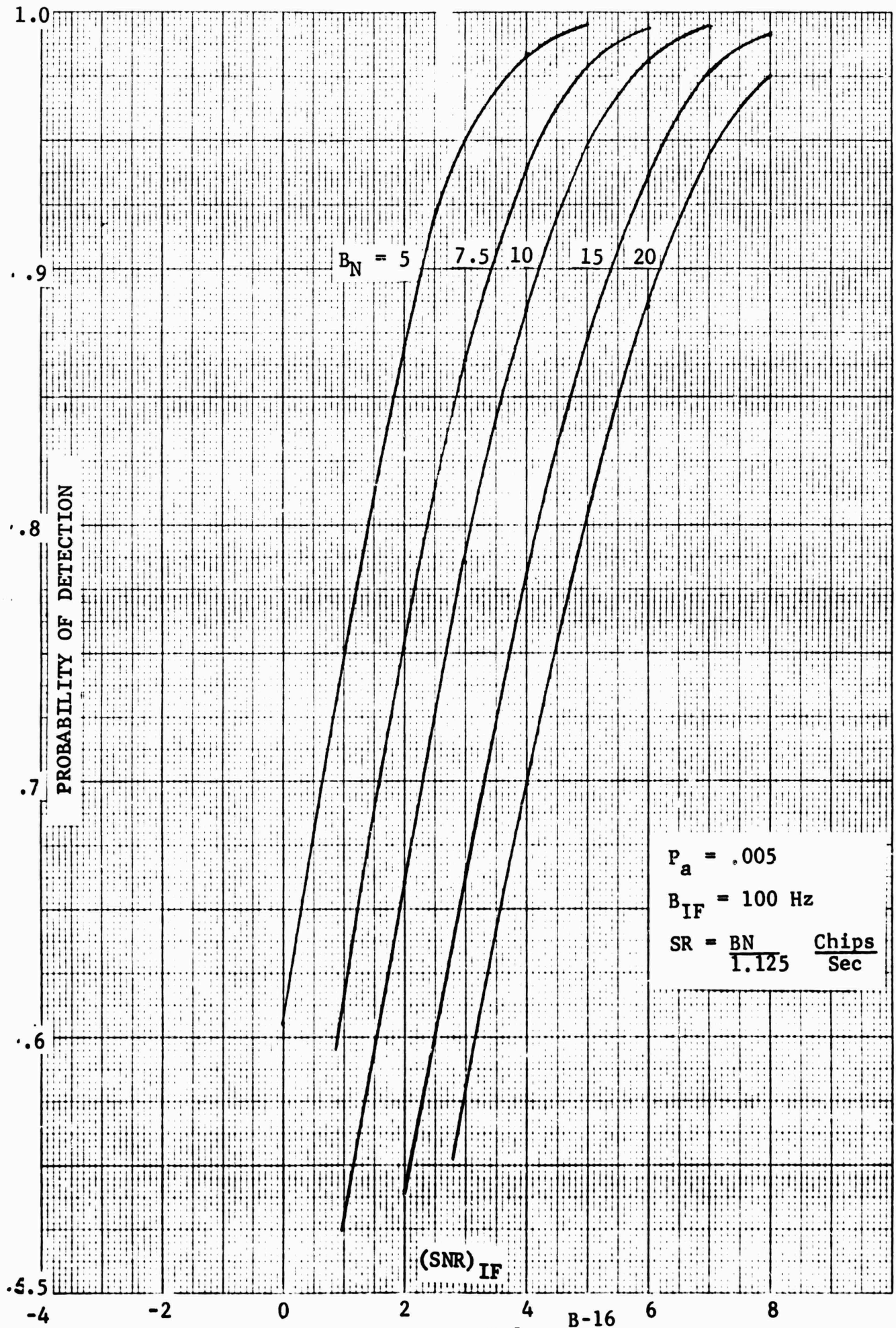

Figure B-9

The in-lock detector shown in Figure 1 has been analyzed. It has been assumed that the bandwidth of the lowpass filter is much narrower than that of the IF filter such that the central limit theorem can be invoked to assert that the decision variable $z(t)$ is a Gaussian process. The probabilities of false alarm and false dismissal (P_a and P_d) have been derived for both transient and steady-state conditions of the system. Numerical results of $(1 - P_d)$ vs several different system parameters have been obtained. It has been shown that the optimum value of T_D/T_C (dwell time/time constant of the lowpass filter) for maximum value of $(1 - P_d)$ is approximately 1.1 for the range of (SNR) being considered.

GPS SPECIAL STUDIES AND ENGINEERING PROGRAM

TASK III - MANPACK STUDY

1.0 INTRODUCTION

This report presents the results of a study concerning the proposed Army manpack GPS user to be operational in the early 1980's. The objectives of the study were to:*

- 1) Provide the Army an insight to the compatibility of the user established performance characteristics as set forth in the Army Mission Requirements Document, YEN-74-98, with the implementation of the GPS manpack.
- 2) Provide tradeoff information to assess the impact of any proposed relaxation of goals
- 3) Provide a recommended approach to the manpack effort.

The report contains three major sections. Section 2 deals with the manpack overall equipment configuration and performance recommendations. Section 3 discusses microprocessor hardware and Section 4 deals with computer functions and software recommendations.

1.1

Study Conclusion Summary

The study conclusions may be summarized as follows:

- 1) The manpack goals (Table 1-1) and scenario do not lead to any major receiver hardware simplification when compared to other users (equipment interfaces are simplified due to the absence of external sensors).
- 2) A manpack set which satisfies the mission requirements of a majority of users as stated in the "Army Mission Requirements Document" can probably be achieved within the unit size, weight, and cost goals (Table 1-1) given extensive LSI development.

Table 1-1 Manpack Development Goals Summary

Horizontal Accuracy (CEP)	1.5 to 50 m
Vertical Accuracy (CEP)	1.1 to 50 m
User Motion	0 to 50 MPH
Interference Rejection	High AJ Desirable
Mission Duration	2 to 48 Hours
Weight	8 to 12 lbs.
Volume	500 to 1000 cu. in.
Unit Cost	\$15,000

- 3) A "full performance" dual manpack/vehicular unit will probably not meet the size weight, and cost goals set forth in Table 1-1, but appears feasible if some relaxation of goals is acceptable.
- 4) A low-cost, low-power computer capable of performing the required navigation computations for the low performance user is feasible using available microprocessors; however the high performance user will require either higher speed, hence higher power, bi-polar technology or augmentation of existing microprocessors with external floating point hardware. The high accuracy user can be accommodated at the expense of computation speed through the user of multiple-precision arithmetic.
- 5) Because of the shorter word length associated with the microprocessor the navigation filter must be implemented as a "square-root" filter to improve accuracy and guarantee stability.

1.2 Study Recommendation Summary

The study recommendations may be summarized as follows:

- 1) It is recommended that the Army consider developing separate low-cost manpack (LCM) and high-performance manpack/vehicle (HPM) user equipments. The anticipated equipment characteristics are summarized in Table 1-2.

- 2) "All-digital" receiver implementation should be pursued with a maximum of operations performed by a micro-computer.
- 3) LSI development of common functional elements should begin as quickly as possible.
- 4) Thick film development of analog circuitry should be investigated.
- 5) Additional investigation into hardware/software trade-offs in receiver control, code generation, data demodulation and floating point computation to determine the optimum division of functions between the processor and dedicated hardware.
- 6) Consider further the feasibility of "add-on" hardware floating-point module to increase computation speed of the microprocessor for use in high-performance applications.
- 7) Recommendations - The navigation filter for the manpack user should be a low-order Kalman filter implemented in square-root form (see Section 4.3.1 and Appendix C).

Table 1-2 MANPACK CHARACTERISTICS SUMMARY

<p>High Performance Manpack/Vehicle Set Characteristics Summary</p>	<p>Low-Cost Manpack Set Characteristics Summary</p>
<ul style="list-style-type: none"> ● Dual manpack/vehicle use. ● 10 m (CEP) position accuracy. ● Maintain accuracy in the presence of 40 dB of jamming. ● TTF on the order of 1 minute. ● 12 hour continuous operation on internal batteries. ● 23 lbs. total weight. 	<ul style="list-style-type: none"> ● Manpack use only (0 - 5 mph). ● 20 m horizontal position accuracy (CEP). ● 10 m vertical position accuracy in "high vertical resolution" mode. ● Maintain accuracy in the presence of 30 dB of jamming. ● TTF on the order of 4 minutes. ● 12 hours of continuous operation. ● 12 lbs total weight.
<p>Anticipated Cost \$25,000 to \$35,000 (1000 production units)</p>	<p>Anticipated Cost \$10,000 to \$15,000 (1000 Production units)</p>

SECTION 2

2.0 MANPACK CONFIGURATION

2.1 Manpack Development Goals

It is the Army's objective to develop a small, lightweight user equipment for manpack as well as wheel and track vehicle use. The manpack user equipment (MUE) is intended to satisfy needs for a wide variety of missions (see Ref. 1) and would preferably require that only one equipment be developed in order to achieve lowest acquisition and maintenance costs. Present MUE goals are:

Weight: 8 - 12 pounds
Volume: 500 - 1000 cubic inches
Mission Duration: 48 hours
Unit Cost: \$15,000

Required performance is mission-dependent and varies considerably. The range of performance is summarized below.

Horizontal Accuracy (CEP)	1.5 to 50 m
Vertical Accuracy (CEP)	1.1 to 50 m
User Motion	0 to 50 mph
Interference Rejection	High AJ desirable
Mission Duration	2 to 48 hours

An example manpack set is shown in Figure 1.

It is obviously difficult to accurately predict the ability to meet these goals in five years time in the rapidly changing technology and economic situations of today. Unit end cost is especially difficult to predict since a low per unit cost may be achieved only through high development costs. For example, the size, weight, and cost reductions exemplified.

Ref (1) "Army Mission Requirements Document," YEN-74-98.

by today's microprocessors were realized through extensive development programs justified by the vast potential market and the "universal" character of the computer.

In view of the uncertainties involved, we have tried to be relatively conservative in our estimates of what can be accomplished. Further, the recommendations are intended to provide direction for developments which will lead to the most satisfactory solutions regardless of absolutes.

2.2 Recommended User Classes

Present circumstances do not justify the assumption that one manpack/vehicle UE which satisfies all the mission requirements can be developed by 1980 within the size, weight and cost goals stated above (for a total production of ~5000 units). Of these, the cost goal would seem to be the most difficult to achieve for a unit with the required performance and close to the desired size and weight.

The ultimate manpack goals, as presently stated, are such that required complexity appears to be approximately the same as the set "X" or as a minimum, the set "Y" presently under development. The low user dynamics (0 - 50 mph) do not seem to allow any major simplification other than that external sensors are not necessary. Thus the manpack receiver requires a microminiaturized, low power version of a complex receiver. Such a receiver will probably not come at low cost, even in relatively large quantity. We would expect the price to be somewhere between \$25 and \$35 thousand dollars per unit in quantities of 1000 units.

The end price depends, of course, on the number of units purchased from a single supplier at one time as well as total expected production. A buy of 100 units, which is probably a

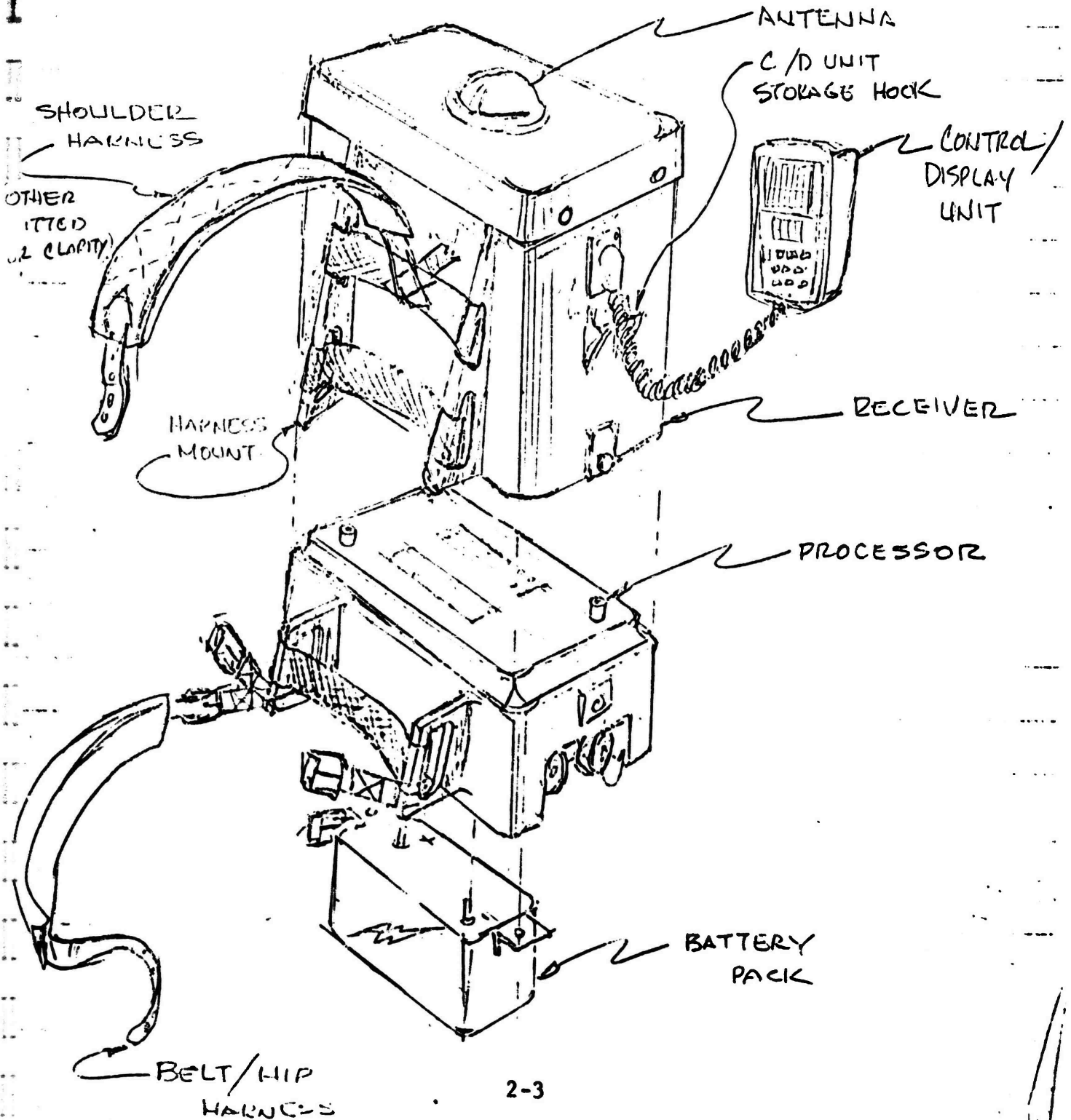

more realistic quantity in the early stages of system operation, would result in considerably higher cost, probably in the range of \$35K to \$50K (excluding any development costs).

Many of the missions for which the manpack is intended have requirements which could be met with a UE of significantly reduced complexity and cost. In particular, it appears that L1 C-signal only operation using a single channel, slow sequencing receiver could provide position accuracy on the order of 20 meters, for a user with a 0 - 5 mph velocity, under most conditions. The estimated price of such a receiver is on the order of \$10 to \$15 thousand dollars in quantities of 1000 (\$15 to \$20 thousand dollars in lots of 100 excluding nonrecurring costs). The major disadvantage is the reduction in AJ performance. Thus it is recommended that the Army consider development of two manpack/vehicular UE as follows:

- A full capability equipment for dual manpack/vehicular use
- A L1 C-signal only receiver for manpack use

A more complete discussion of the development recommendations and problems is given below.

2.3 High Performance Manpack

The High Performance Manpack (HPM) is intended to meet stringent mission requirements with design goals and features:

- Dual manpack/vehicle use
- 10 m position accuracy (CEP)
- Maintain accuracy in the presence of 40 dB of jamming
- TTFF on the order of 1 minute
- 12 hr continuous operation on internal batteries
- 23 lbs total weight

The above goals imply

- L1/L2 operation
- P-signal operation

The complexity of such an equipment is assumed to be approximately that of the "X-Set" equipment presently under development. The somewhat reduced dynamic environment does not seem to allow any major simplification other than that external sensors are probably not required.

The receiver configuration would ideally be a fully continuous 4-channel receiver, however this is not a likely choice unless new developments in the code tracking loop circuitry bring about a reduction in size and cost. Another potential configuration provides continuous carrier tracking but employs a single time-sequenced code loop. This is the technique being implemented for the present "X" set. The third choice of a single code/carrier channel time-sequenced over the various signals has considerably reduced AJ performance and is not recommended for the HPM.

2.4 Low-Cost Manpack

The recommended low-cost manpack (LCM) is basically a C-signal only, slow sequencing receiver, designed to provide moderate performance, adequate for many missions, with a minimum of equipment size and cost.

The use of the C-signal simplifies both circuitry and operational difficulties. This is gained at the expense of accuracy and AJ performance. The ranging accuracy is not greatly reduced from the P-signal for a low dynamic user. Range accuracies of 10 feet should be easily achieved for the manpack user. Ionospheric errors are a major source of errors if the C-signal is transmitted on L1 only. Simple modeling

can limit the error to about 15 feet under most circumstances. It is possible that this error can be further reduced by inputting predicted delays for missions of short duration, more complicated models, or meteorological data received through an auxiliary link. Figure 2 shows a typical situation.

The Army missions requirements (Ref. 1) indicate that the LCM would be especially useful if a vertical position accuracy on the order of 10 m can be achieved. Thus a "high vertical resolution" mode is suggested in which satellite selection and position computation are optimized in the vertical direction.

The LPM is intended to have the design goals

- 20 m horizontal position accuracy (CEP)
- 10 m vertical position accuracy in "high vertical resolution" mode
- Maintain accuracy in the presence of 30 dB of jamming
- TTFB on the order of 4 minutes
- Manpack use only (0 - 5 mph)
- 12 hrs of continuous operation
- 12 lbs total weight

It is anticipated that the LCM would be implemented as a slow sequencing receiver (similar to the "Z" set presently under development). Some of the advantages and disadvantages of the LCM are listed in Table 2-1. A skeleton specification for the LCM is included as Appendix A.

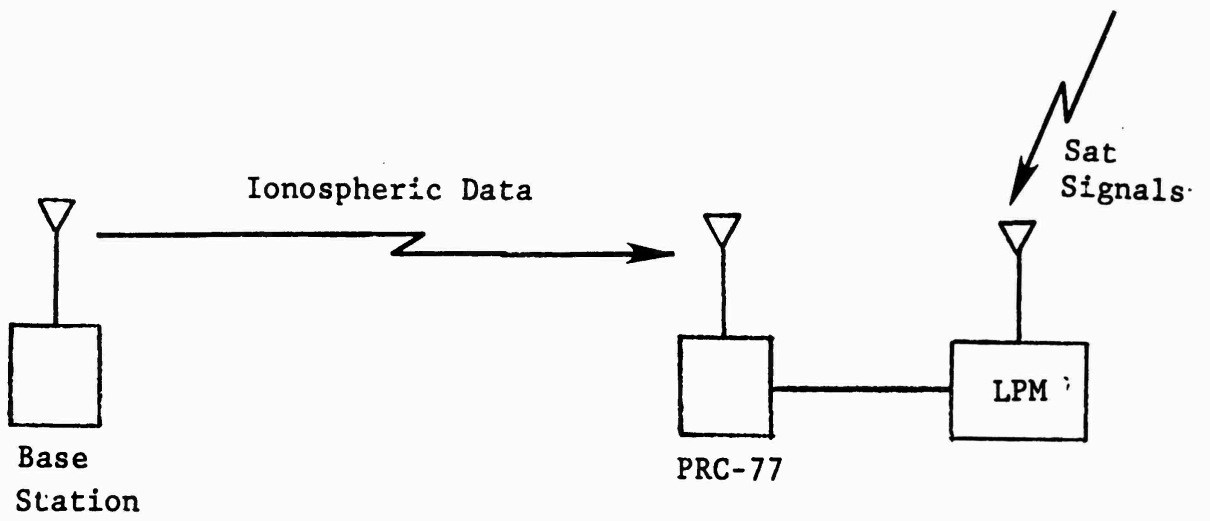

Figure Auxiliary Data Link to Reduce LCM Ionospheric Errors

Table 2-1 LCM Features

FEATURES

- Single frequency operation
- No P-Code generators or acquisition circuitry required
- No secure code key or "HOW" required
- Rapid reacquisition
- Single channel code and carrier tracking circuitry
- Fully automatic and "autonomous" operation

DISADVANTAGES

- Sequential operations increase TTF
- Interference resistance reduced by about 10 dB
- Resulting accuracy of 20 to 30 meters

Comparison of HPM and LCM

The recommendation to develop two manpack units is predicated on the assumptions that

- A high performance receiver will cost significantly more than \$15K even in quantities of 1000 units
- The need to accomplish missions requiring high performance is such that the cost of the equipment is justified
- A much simpler and lower cost unit can be developed which will meet the needs of a large number of users

The LCM savings are gained through reduced accuracy, near stationary user (manpack only), less AJ protection, and longer TTF as discussed in the preceding sections.

The possible simplifications may be summarized as follows. The reduced accuracy and AJ performance allows

- single frequency operation (increased ionospheric error)
- C-signal tracking only (lower ranging accuracy and AJ protection)
- simpler software and CPU (lower computational accuracy)

The near stationary user (5 mph) and longer TTF leads to the possibility of

- single channel slow sequencing operation without overly complex control hardware and software
- no external sensors

Some insight into the comparative complexity of the two equipments may be gained from Figure 3 . The overall block diagram represents the HPM while the shade elements indicate those required for the LCM.

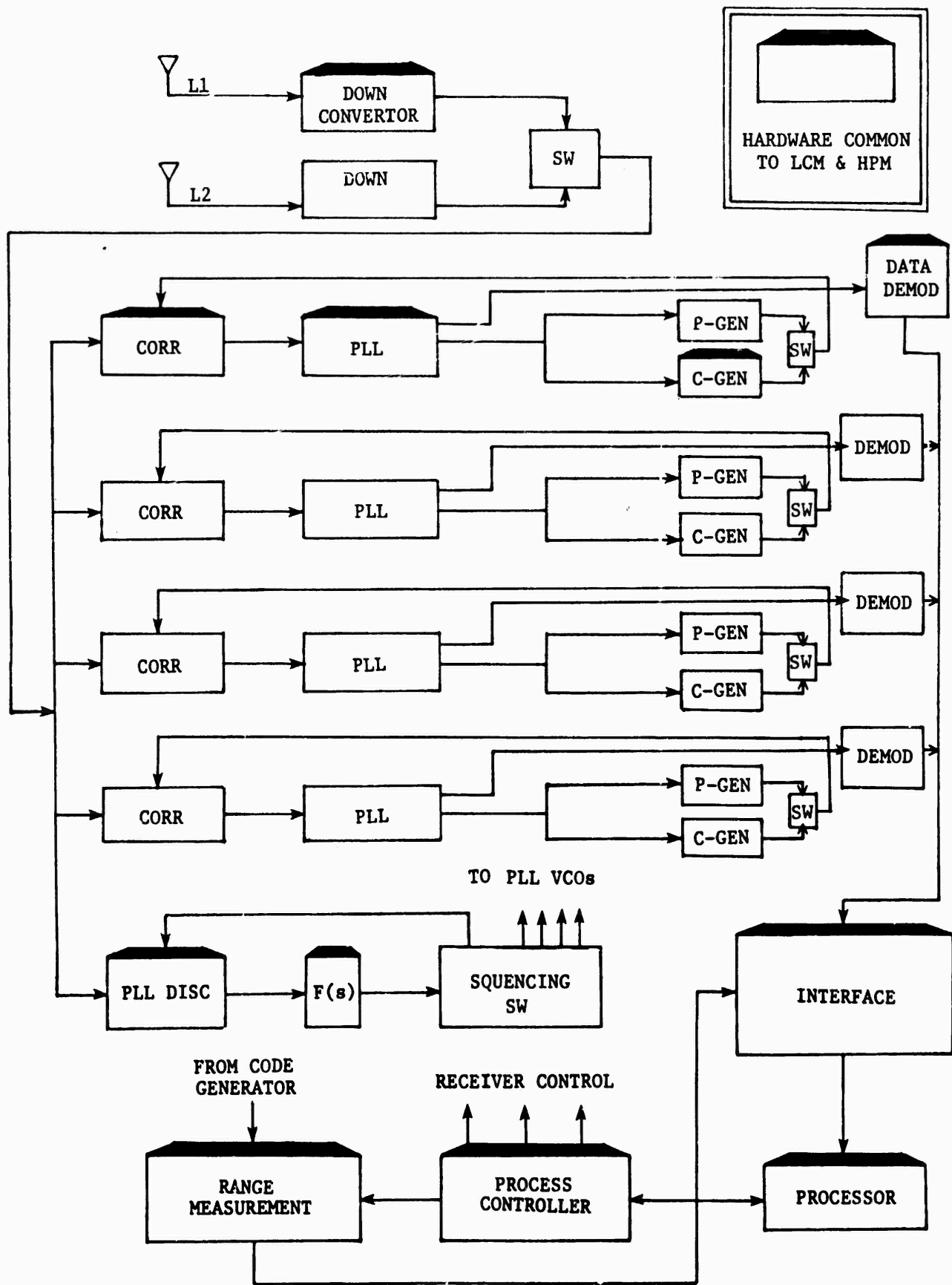

FIGURE 3

CONFIGURATION FOR COMPARING HPM AND LCM COMPLEXITY DEMOD

Power dissipation is one of the most critical design areas, since the battery pack is a major contributor to the UE size and weight. Further, heat dissipation in the small volume of the manpack can have a critical effect on component temperature. For example, the "Y" set presently under development is estimated to require 543 watts of power including 45 watts for six cooling fans.

Lithium batteries presently under development represent a major breakthrough in battery technology, providing about an order of magnitude improvement in energy storage per pound of battery weight over other rechargeable batteries (see Appendix B). Assuming a battery capacity of 150 w-hr/lb for estimation purposes, a pound of battery is required for every 12.5 watts of equipment power for a 12 hour mission. Three pounds of batteries could thus provide 37.5 watts of continuous power. Low power logic technology is rapidly improving which will help in meeting this design requirement. A major reduction in power consumption is achievable through judicious use of power switching of components that do not require continuous operation. There is, at present, about a 4 to 1 difference in power consumption for digital logic with maximum operating speeds of around 10 Mbps and 1 Mbps. Thus there is apparent advantage to C-signal only operation in addition to reduced complexity.

The HPM is expected to require about 45W of battery power. Note that this is approximately an order of magnitude less than the present Y-set development model. This reduction in power is hoped to be gained through careful attention to circuit configuration for minimum power dissipation, use of low power logic and components, and power switching.

The LCM is expected to require about 25W of battery power. The reduction over the HPM is due to less complicated circuitry as well as lower clock rates.

The size goal for a manpack receiver is to achieve a volume of less than 1000 cu. in. including the battery pack. This corresponds to something greater than a 5 to 1 reduction in volume of the Y set presently under development. A reduction of this magnitude does not seem entirely out of the question using existing techniques, as may be inferred from the reduction in computer size that is realized with the microprocessors now available. It must be remembered however that the extensive LSI developments required were undertaken because of the "universal" nature, and therefore large potential market, of the device. The state-of-the-art and availability of microprocessors is such that they should be employed to the maximum extent possible in place of special purpose LSI components. Where this is not possible, due to processing speed, it would seem most cost-effective to develop LSI devices to be made available to all UE manufacturers, e.g. single LSI code generator chip would be developed as opposed to each manufacturer attempting to develop his own. In order to take advantage of the rapid progress in digital circuit technology, a maximum of the receiver functions should be implemented digitally.

The analog circuitry is probably best handled with thick film techniques, with the possible exception of the L-band circuitry, where thin film may be more advantageous. While it appears that thick film implementation of the IF and low frequency analog circuitry is practical, experimental development work is required to substantiate this conclusion.

2.8

Weight

Equipment weight depends largely on the extent to which LSI and microminiaturization analog circuitry is employed, as well as the module packaging and functional integration employed, i.e. if several functions are integrated in one chip, and the number of separate module covers and interconnectors are minimized, the weight will be reduced over a receiver employing a lower level of chip and module integration. Power consumption also affects weight since the battery weight is considered as part of the equipment weight.

The HPM is expected to weigh about 23 lbs. including 4 lbs. of batteries, while a total weight of 12 lbs. seems reasonable for the LCM (including 2 lbs. of batteries).

2.9

Receiver Hardware

The manpack effort is primarily one of microminiaturization. In order to be successful, the Army program should:

- Exploit microprocessors to the fullest
- Start LSI development of certain common functional blocks
- Start thick film development of analog circuitry.

The basic block diagram for the manpack user equipments (UE) is shown in Figure 4. A more detailed block diagram of a single correlator, carrier tracking loop, noncoherent code tracking loop, and data demodulator is shown in Figure 5. There are, of course, many versions of this circuitry and this particular one is used only as an example.

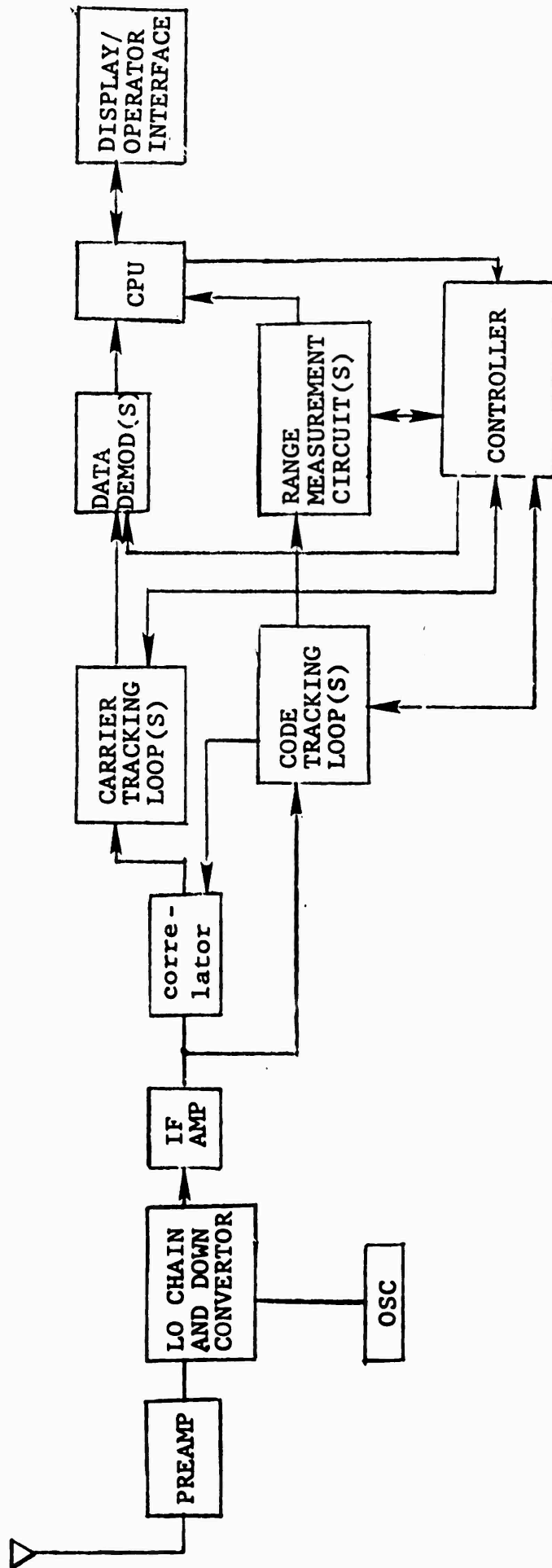

Simplified Manpack Set Block Diagram
 Figure 4

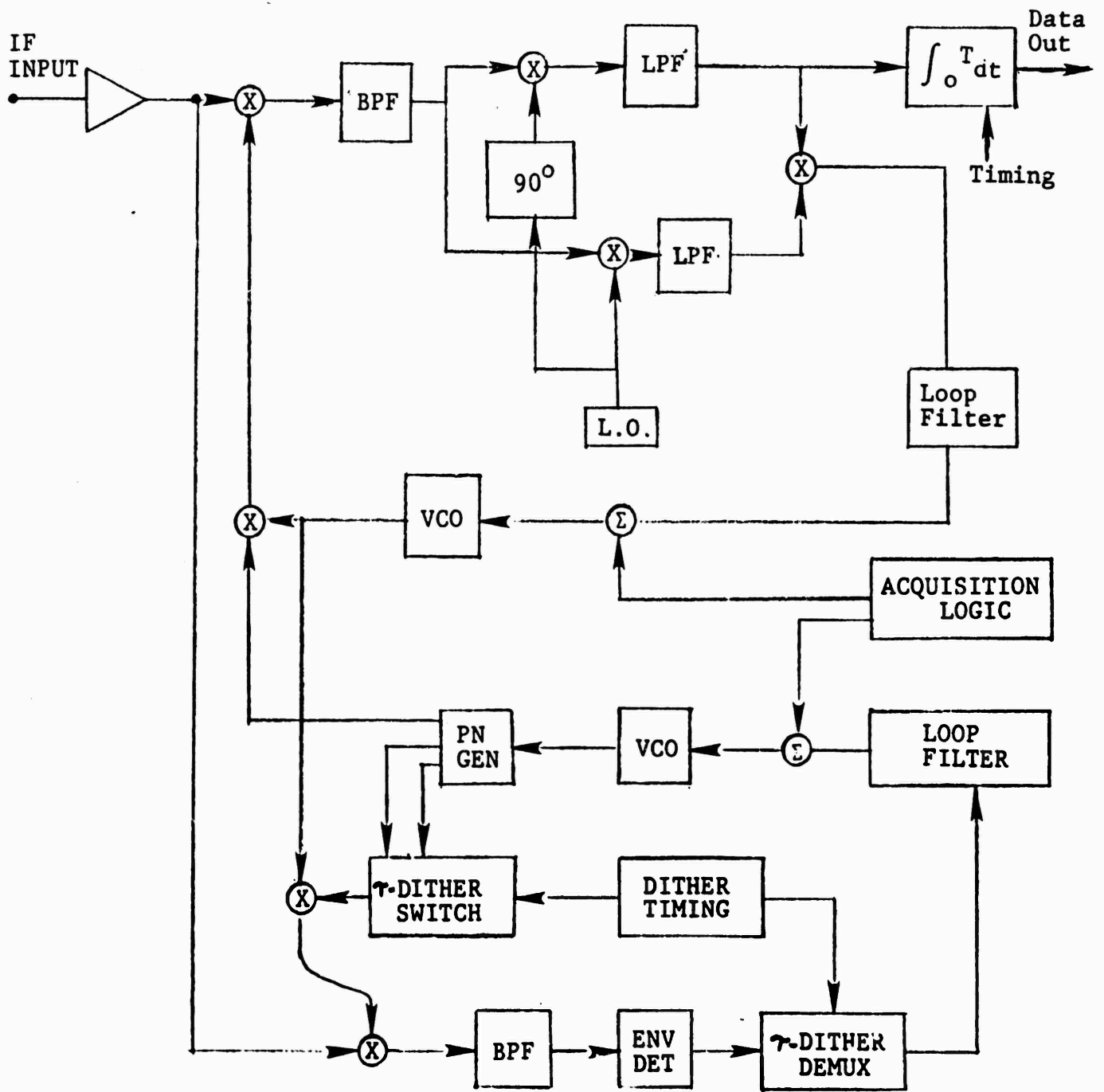

Example Carrier and Code Tracking Loop

Figure 5

This circuitry and the associated control logic represents most of the complex circuitry in the receiver and is a candidate for nearly all-digital implementation. A block diagram of the digital version is shown in Figure 6. The dotted lines represent functions that can probably be performed by a microprocessor while the crosshatched blocks represent digital LSI.

It is desirable to perform as many operations as possible with microprocessors, due to the availability and cost. Some functions must be done in LSI firmware, however, due to processing speed limitations.

The sampling rate and the number of bits used in A/D conversion must be chosen such that the digital processing introduces negligible degradation. These parameters require careful selection in the design process. The data detection filter must process samples at about 10 times the data rate (i.e. 500 samples/sec) in order to introduce less than 0.5 dB of degradation (Ref. 2). Experience has shown that 4 bits of quantization (16 levels) is usually adequate to ensure negligible degradation in BER due to quantization noise. Four-bit (16 level) quantization is adequate. The carrier tracking loop filter can operate at a somewhat lower rate, on the order of 100 to 200 samples/second for loop bandwidth from 20 to 40 Hz. Three bit quantization is recommended although fewer bits could be used. The code tracking loop need only operate at around 20 to 50 samples/sec due to the very low bandwidth (<10 Hz) involved. All of the above rates are within microprocessor capabilities. Some of the other functions, such as code generation and the digital number-controlled oscillator (NCO) involve high clock rates and probably will require dedicated LSI hardware.

Ref (2) F.D. Natali, "All-Digital Coherent Demodulator Techniques," ITC Proc., Los Angeles, California 1972.

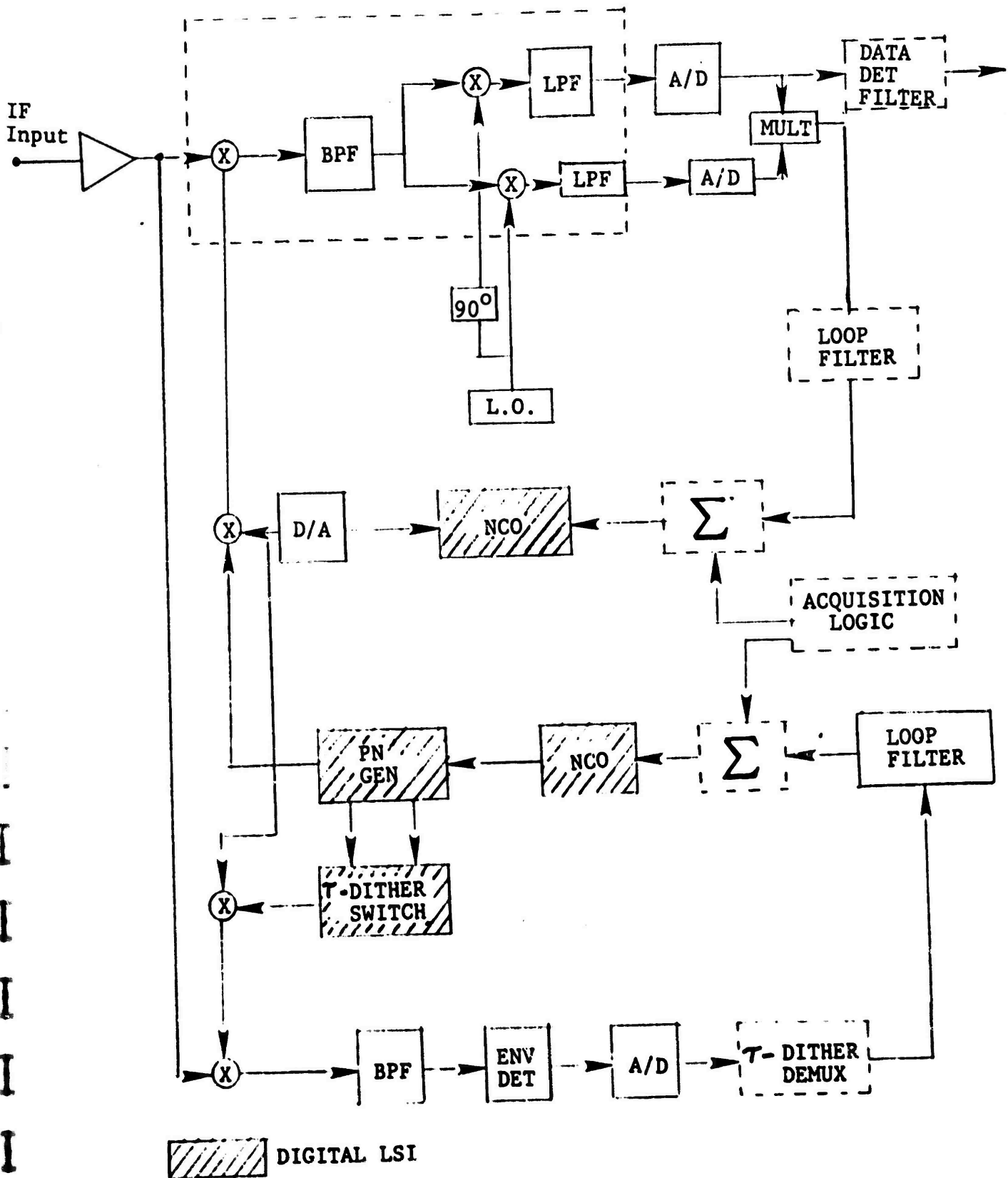

 **DIGITAL LSI**
 **Microprocessor Function**

Figure 6

Digital Implementation of Carrier and Code Tracking Loops

due to the very low bandwidth (<10 Hz) involved. All of the above rates are within microprocessor capabilities. Some of the other functions, such as code generation and the digital number-controlled oscillator (NCO) involve high clock rates and probably will require dedicated LSI hardware.

The correlator, as shown, is implemented in an analog fashion. This approach is recommended over a digital implementation with present technology since digital correlation involves high clock rates as well as considerable complexity, and there does not appear to be any particular advantage to be gained since most of the analog circuitry is passive.

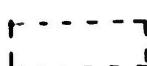
The HPM would ideally incorporate four signal tracking and data demodulation channels. Microprocessor architecture is such that similar functions can be performed for all four channels by a single processor if adequate speed is available. As noted above, a single channel requires relatively simple processing of about 700 samples/second and four channels would thus require processing about 2800 samples/second. The sampling requirements are summarized in Table 2-2.

The functions denoted as LSI hardware require higher speeds and are not expected to be accommodated by computer-type architecture. The question then arises as to whether size or cost savings can be achieved by time-multiplexing certain high speed LSI elements. The code generators do not seem to be significantly simplified by time-sharing common circuit elements and independent implementation seems the best choice. The NCO, on the other hand, may benefit from time-sharing of certain elements, depending on the technique employed. A possible block diagram of a four-channel receiver employing time multiplexed hardware is shown in Figure 7.

Table 2-2
Summary of Sampling Requirements

Function	Bandwidth	Recommended Sample Rate	Quantization
Data Detection	$R_D = 50 \text{ Bps}$	$\geq 500 \text{ samples/sec}$	4 Bits
Carrier Tracking Loop	$B_L \leq 40 \text{ Hz}$	$\leq 200 \text{ samples/sec}$	3 Bits
Code Tracking Loop	$B_L < 10 \text{ Hz}$	$< 50 \text{ samples/sec}$	3 Bits

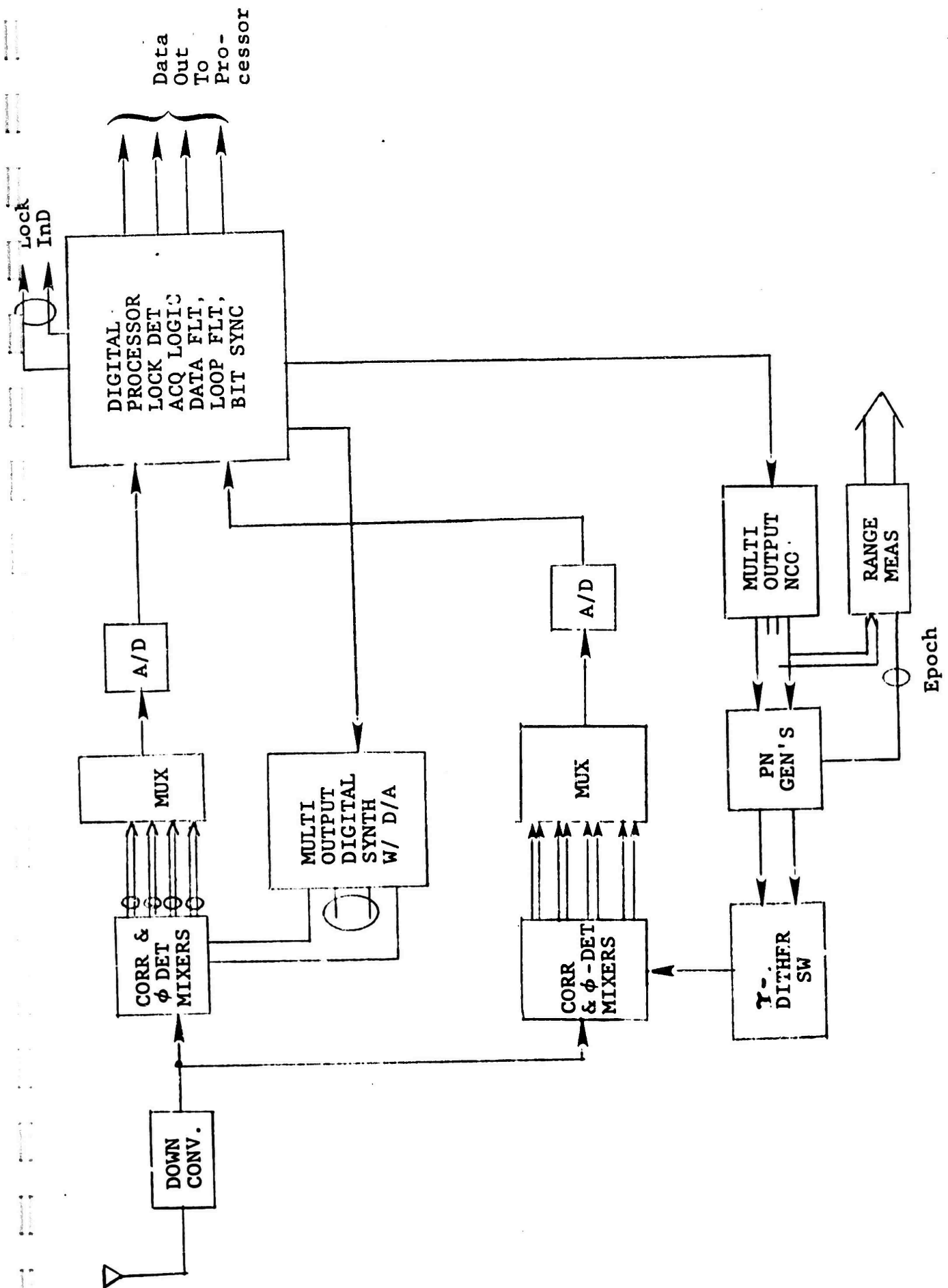

Figure 7 Example Implementation of a Four Channel Set

3.0 MICROPROCESSORS AND MICROCOMPUTERS

3.1 Introduction

The size, power and weight requirements for the manpack unit influence to a great extent the choice of computer. Because of these factors, use of existing aerospace computers in manpack operations would greatly compromise the design. Fortunately certain of the microprocessors presently being developed offer smaller size, reduced cost and much lower power consumption.

In the present baseline design the computer is responsible for both calculation and receiver control, although separate circuits for these functions are being considered. At the present time a 16 bit binary machine with floating point capability appears to provide acceptable accuracy (6 to 7 digits) as long as procedures which are tolerant of round-off errors are employed, particularly in the Kalman filter routine.

For higher precision one alternative to going to 24 or 32 bit machines or to double precision software on a 16 bit machine is to utilize BCD arithmetic, which allows essentially unlimited computational accuracy given enough time. Trading increased computation time for reduced hardware requirements appears to be one area that can yield considerable benefits for the manpack design.

There are a number of microprocessors either available or soon to be available which would have generally suitable characteristics, including the Teledyne TDY52A and TDY52B, the Intel 8080, the Intersil 6100 (PDP-8 code and CMOS construction), the RCA COSMAC (also CMOS) and the National Semiconductor IMP-16. The major difficulties with using these microprocessors is the lack of higher level languages

(except for the Teledyne, Intel and Intersil machines) and their special interfacing requirements. One feature that must be carefully examined is the ability to mix RAM and ROM memory and the capability of addressing sufficient memory (at least 16K) to hold all of the required programs. Another feature that is particularly important for manpack use is external interrupt capability to allow the receiver to signal the computer that receiver functions are complete. Other characteristics that must be carefully examined are the size and power consumption of the total package with all required memory and interface chips, along with the other considerations of speed, second sourcing and price.

One of the interesting developments that may be of great significance in the early 1980 time-frame is the recent introduction of computer "slices." These chips are usually either 2 or 4 bits of a complete CPU which may be stacked together to form a computer with any desired word length, freeing the designer to select the particular word length which suits the problems and reducing the complexity of software required to maintain suitable accuracy with short word length computers.

3.2 Review of Present Microprocessor Technology

At the present time the number of microprocessor types is rapidly increasing with at least 26 different models either presently available or available in the near future. Intel Corporation has five models - two of them are 4-bit microprocessors to 8-bit microprocessors and a bi-polar slice kit which can be used to make computers up to 32 bits wide. National Semiconductor has five models - three of them in their IMP line, one called GPC/P, and a recently introduced single chip 16-bit model called PACE. Rockwell has both a 4-bit and an 8-bit chip set. Both RCA and Intersil have

complementary MOS (CMOS) chips which are attractive because of the very complete interfacing chips that are available for use with the basic CPU.

In addition to these manufacturers, Fairchild, Signetics, Electronic Arrays, Micro Systems International and Toshiba also produce an n-channel device, while Mostek, Burroughs, and Fairchild offer p-channel systems. Monolithic Memories, Raytheon and Transitron build 4-bit microprocessor slices using bi-polar technology. Texas Instruments is planning to introduce a 4-bit slice using current-injection logic (I^2L) which has the unique property that power consumption can be traded for increased speed simply by increasing the supply current. Actron Industries is presently producing a control unit and an arithmetic unit as custom chips for a 16-bit machine which can be expanded in eight bit slices up to 80 bits for use as a standardized avionics module for the Air Force. Honeywell is developing a complete micro-computer, the MOD/LSI-2, for use in small missiles, which may be suitable for manpack use and because of its large volume use in missiles may be reasonably priced (however, very little data on this device is available).

3.3 System Considerations in Microprocessor Selection

At the present time, most of the single chip microprocessors are considerably slower and less flexible than existing minicomputers. Comparison of the execution time for several microcomputers and minicomputers show that the execution time can be between about 2 and 4 times slower in the case of the microcomputer. The primary reason for this is that the microprocessors typically are based on metal oxide semi-conductor technology while the minicomputers are built using bi-polar devices. Another important reason for the difference in speed is that most of the microprocessors use a smaller number of bits - typically either 4 or 8 bits. One way of comparing the speed of microprocessors and mini-

computers is to measure the execution time for typical functions which would be performed in the system. Comparison of execution speeds of an 8 bit Intel 8080 microprocessor which is representative of types presently available on the market and an Inter-Data 50 minicomputer which is a typical 16-bit bi-polar minicomputer, shows that for a typical error check operation, such as for a cyclic redundancy check code, the Intel 8080 takes somewhere between 250 and 320 microseconds to execute whereas the Inter-Data 50 will execute that same set of instructions in 12 to 15 microseconds. The reason for this discrepancy in execution times can be traced to the relative slowness in executing individual instructions of the microprocessor. Again, comparing the Intel 8080 and the Inter-Data 50, subtraction or addition takes about 2 microseconds for the 8080 and only 1 microsecond for the Inter-Data, register loads take about 3.5 and 1 microsecond respectively, and memory reference instructions require about 3.5 microseconds and 3.25 microseconds respectively. For these relatively simple instructions the microprocessor and the minicomputer compare quite favorably with only a 2-to-1 or 3-to-1 time advantage for the minicomputer. However, when more complex instructions such as multiply and divide must be executed, the minicomputer has a considerable advantage. For example, for a multiply of 8 bits by 16 bits the Intel 8080 would take an estimated 230 microseconds compared to just over 5.5 microseconds for the Inter-Data 50. Division times are slightly longer, on the order of 270 microseconds versus about 10 microseconds for the Inter-Data 50.

These examples show that considerable care must be exercised in choosing a particular microprocessor or microcomputer for the manpack, and that speeds must be compared on the basis of typical complex operations, rather than just on cycle time. In addition to computation speed one must carefully examine the type of software that is available

for the computer and how the programmer can use this software to best advantage. Some of the considerations in software design are word size, both for data and instructions, the ability to address a large number of memory locations (which influences the number of words in the program), the number of registers which are available for arithmetic for indexing and for other uses such as push down stacks and the number and type of addressing modes that can be used such as immediate, relative, and relative to program counter.

A second major consideration is the hardware design including the type of technology used whether it be P-MOS, N-MOS, C-MOS, or bi-polar, which will in turn influence power dissipation, voltages, speed, compatibility with other parts which determines the amount of interfacing required, and finally the size of the overall package.

The third major consideration is how the hardware and software design influence the system. Here one must look at the number of external interrupts, how many chips are required to implement the microprocessor, whether or not it is microprogrammable, whether it has DMA capability if large amounts of external data must be transferred into memory, and the amount of software support available from the manufacturer, including documentation, application notes, design aids and field service. Other system considerations are the price, the availability, and whether or not the part is second sourced by other manufacturers.

3.4 Software Support

The available software support for microcomputers is very important since having to write the software involves a considerable amount of money. Some of the types of software that

should be available with any microprocessor are an assembler, a monitor for debugging the microprocessor, an editor for changing programs and a simulator that will allow the microprocessor program to be executed on a larger computer.

The ability of the operator to program the computer using higher level languages such as FORTRAN are not as important in the manpack application as they might appear. One reason is that the manpack processor is a high volume design, thus any reduction in memory size resulting from the generally more efficient code produced by a good programmer writing directly in assembly language would probably result in a cost savings (as well as an increase in speed). Another point to be considered is that a high level language compiler can always be written, if desired, and through the use of specialized microprograms built into the machine can embody features specifically optimized for the manpack application such as trigonometric functions, matrix manipulation, interrupt handling, floating point and data formatting. Matrix manipulations, in particular, would be considerably faster if specialized instructions and microprogramming is available. A final point against providing a resident FORTRAN-like compiler is that a high level language would be of little use to the manpack operator since he would not be doing any programming. If a compiler is used at all it would be a cross-compiler, i.e., a compiler running on a larger machine which produces machine code for the manpack processor, probably in the form of a pre-programmed read-only-memory (ROM) which would be inserted into the processor as a maintenance operation. Also, for the operator to be able to program the machine equipment for reading either paper tape or magnetic tape would have to be provided for program entry and these are definitely unsuitable for the environmental conditions under which the manpack will be used.

It is likely that one or more standard microprocessors will be chosen for military applications in order to reduce inventory requirements and to have some commonality in software. At the present time there is no clear picture of what will actually be available by 1980 for military application since most of the devices are intended for civilian applications. However, there does not seem to be any doubt that sufficient technology will exist by 1980, given that currently available microprocessors and semi-conductor memories could in fact be used with some compromises. Rather, it is more a question of guiding development to produce a suitable product and hopefully one with a wide range of application.

3.5 Available Microcomputers

3.5.1 Intel 8080

The most prominent of the 8-bit microcomputers is the Intel 8080 which in many ways is the current standard for 8-bit microprocessors. The present cost is \$360 in single units and is second sourced by Advanced Micro Devices. The chip is an N-MOS dynamic technology and uses ± 5 volt and 12 volt power supplies. It provides an extensive software instruction set including data manipulation instructions for arithmetic and logic, and has both BCD arithmetic and double precision instructions (to string two 8-bit data bits together as a 16-bit word). Data movement instructions use three pairs of general purpose registers as memory address pointers to address both low and high order bits of 16-bit memory addresses and can do multiple indexing at the expense of additional steps. It also has a stack pointer which can be used to create push-down stacks in external memory which would allow unlimited sub-routine nesting. It also has a multiple interrupt capability and can have direct memory access. Intel provides a high level language which they call PL/M, which is based on the P1/1 language.

An 8-bit microprocessor made by Motorola (the MC 6800) is also a potential candidate. The present cost is \$360 for one unit but it is estimated the price will drop to \$30 in large quantities by the end of 1975. American Micro Systems also second sources this unit. The architecture of the machine is very similar to that of the Digital Equipment Corporation's PDP-11, except that it has an 8-bit word length. Execution times for typical instructions are 2 - 5 microseconds. The chip is built using N-MOS silicon gate technology and requires only a single ± 5 volt supply. One of the interesting features of the Motorola device is that a large number of external chips are available which interface directly to the microprocessor greatly simplifying the system design.

As mentioned previously, the software is very close to that of the PDP-11 and provides data manipulation instructions including both arithmetic and logic as well as instructions to take advantage of the presence of two accumulators on the chip. Data movement instructions include instructions for reaching the first 256 memory locations or base page with short instructions and it can process lists efficiently using the index register and relative addressing. The program manipulation instructions have most of the features of the PDP-11 software including branches and conditional branches, as well as unlimited subroutine nesting by using a stack pointer to address a push down stack in external memory. One feature it does not have is vectored interrupt but it can achieve this function at some additional expense in software. Instructions for storing the status register are also provided which is useful when processing interrupts. The software support that is currently available is a cross-assembler, an interactive simulator and a monitor debug. In addition, high level language based or similar to National Semiconductor's PL/M is currently being written. 65K 8-bit bytes of memory can be addressed.

Another 8-bit microprocessor with characteristics that would lend itself to manpack use is made by RCA. Unlike the previously mentioned devices this chip is based on complementary MOS (C-MOS) which gives it considerably lower power consumption, improved noise immunity and the ability to operate over the military temperature range. This chip will be second sourced by American Memory Systems and will be initially supplied as two chips with a single chip version expected in late 1975. The total power consumption is less than 100 milliwatts. Data manipulations instructions include add, subtract, logical, reverse-subtract (which subtracts the contents of the accumulator from the contents of a memory location), 1-bit right shifts and the ability to do "immediate instructions." Data movement instructions allow the relatively simple addressing of up to 65K of memory by using a 4-bit register to select pointers in a 16 x 16 array which then defines the memory location to be operated on. The 16 x 16 array also gives the microprocessor the ability to jump to sub-routines by having a 4-bit register address different registers in the 16 x 16 array as if they were the program counter. Return from sub-routines is done in a similar manner by readdressing the original general purpose register as the program counter. Additional stacks can be created in external random access memory by using the pointers to index these stacks. Software support available at the present time is in a cross-assembler written in Fortran IV which is available on time-sharing networks.

One of the disadvantages of 8-bit architecture is the additional time required to execute instructions that require the manipulation of more than 8 bits of data. For this reason machines with 12 and 16-bit capacities appear to be preferred. One machine which is an interesting hybrid between an 8-bit and a 16-bit processor is the CP-1600 made by General Instrument Corporation. Although the arithmetic logic unit is an 8-bit device the machine externally appears to be a 16-bit machine. The architecture of this machine is similar (like many of the others) to a PDP-11. The typical instruction speed execution time is 1.6 to 4.8 microseconds. Data manipulation instructions that are available include add, subtract and logicals, a double precision add, subtract and logicals which could be very useful in the high precision navigation routines, as well as arithmetic and logical shifts of 1 and 2 bits. It is also similar to the PDP-11 in that eight of the additional general purpose registers on the CPU chip can be used as additional accumulators. It can also address 1024 words in the base page and like the PDP-11, treats all peripheral devices as if they were memory. The program manipulation instructions available are conditional branches and the ability to address memory locations relative to the program counter up to ± 1024 words is provided. The machine also has priority interrupt with self-identifying vectors which will greatly speed up the response time to interrupts. One slight disadvantage is that no index register is available but the same function can be achieved using one of the general purpose registers as the index register. Available software includes a cross-assembler and debug monitor, simulator, diagnostics, as well as a sub-routine library.

The IMP-8 and IMP-16 are 8 and 16 bit multichip microprocessors manufactured by National Semiconductor. These microprocessors are based on a 4-bit CPU slice called a RALU which has 7 registers (4 of which are directly accessible to the programmer), a 16 word push-down stack and a four-bit arithmetic logic unit (ALU). Instructions are decoded by the Control Read Only Memory (CROM) and used to control the RALU up to 100 23 bit micro-instructions are stored in each CROM. Additional CROM can be paralleled to add user-supplied instructions or instruction set extensions.

One CROM presently available extends I/O instructions to permit block transfer of data, memory search and stack-store/restore. Another available CROM includes extensions for multiply-divide, double precision add-subtract, bit testing and byte-handling. Typical instruction times are 4.6 μ sec for a register-to-register add, 7.7 μ sec for a memory-to-register add and 10.5 μ sec for a register input-output instruction.

The typical instruction is executed in 10 μ sec with a 2 μ sec microcycle time (i.e., 4 to 5 microcycles/instruction). Complex operations involving many instructions take considerably longer. For example software multiplication of a 16 bit number in one accumulator by a 16 bit number in another accumulator to produce a 32 bit product requires almost one millisecond. However, in comparing these execution times with those for eight bit machines it must be remembered that the precision here is twice that of the eight bit machines.

A number of system interface chips are being developed to reduce the total system package count. In addition, a stand-alone development system with CPU, RAM, ROM and I/O interface card is available. National also plans to introduce a high level language based on PL/1 called SM/PL.

3.5.6 PACE

The PACE microprocessor by National Semiconductor is a 16 bit single chip version of their earlier multichip IMP-16. It has 45 instructions, four general purpose accumulators that are accessible to the programmer, a 10 word push-down 16 bit stack (LIFO) and six vectored priority-interrupt levels. The push-down stack is particularly useful for nesting the return addresses during subroutine branching. The general purpose accumulators give a great deal of flexibility in addressing modes. PACE can also handle 8 bit data efficiently. Both direct and indirect memory addressing are provided. Direct memory addressing permits the programmer to specify a memory location that is either on the base page (256 words) or ± 127 locations relative to either the program counter or index register. The relative addressing helps to prevent the rather small base page from being used entirely just by linkages between pages. Indirect addressing, which uses the contents of a particular memory location as the address, can be done relative to two of the four accumulators used as index registers, relative to the program counter, or using the base page. Up to 65K words of memory can be addressed in this manner. Since I/O devices are treated as memory locations the available addresses may be divided between RAM, ROM and I/O devices as desired.

Table 3-1 Microcomputer Development Systems

Development System	Micro-processor	Memory Capabilities	Input-Output Capabilities	Built-in Software	Display Functions	Switch Functions	Unit Price for Std. Configuration
MS-200 (Atmel Corp.)	Intel 8080	2K bytes of RAM for ROM, PROM simulation; 1K x 4 bits of RAM for data. Both ROM and RAM expandable to 4K. PROM programming.	Teletype interface, four 4-bit outputs; five 4-bit inputs	Assembler, debugger, paper tape editor	16-bit address display, 8-bit instruction display; five status lamps	16-bit address entry; eight function switches	\$2795
LDS-1000 (Carnegie-Leger, Inc.)	LDS uses Intel 8080, MDS uses Intel 8080	12K bytes of RAM, 512 bytes of PROM; expandable to 4K of mixed RAM and PROM. PROM programming and PROM burning.	Teletype interface; two 8-bit inputs; one 4-bit output; two I/O peripheral connectors with logic	Debugger (assembler, editor, and PROM burning program are on paper tape)	Run indicator	8-bit address entry; three function switches	LDS: \$29K MDS: \$150
MS-100 (Digital Equipment Corp.)	Intel 8080	4K of ROM; 4K of RAM in any combination (expandable to 16K). PROM burner.	Teletype interface; 8-bit parallel TTL interface	Assembler, editor, debugger	Optional	Optional	Price for minimal configuration is about \$1500
Intel 8080 (Intel Corp.)	Intel 8080	4K bytes of RAM (4K bytes of PROM can be added). Data RAM is 12K bytes; expandable to 25K. PROM programming and PROM burning.	Both the Intel 8080 and the 40 have eight 4-bit outputs (expandable to 43). The 40 has four 4-bit inputs, the 40 has three 4-bit inputs, and an interrupt line.	System monitor (includes tape loader and debugger). Assembler (includes paper tape editor)	System status lamps (the 40 has seven lamps); 12-bit address display; 8-bit instruction display; 4-bit processor data bus display; 8-bit memory address pointer display	12-bit address or data entry; 4-bit search address entry; 15 function switches (the 40 has 16 switches)	Intel 8080: \$125 Intel 8085: announced
Intel 8085 (Intel Corp.)	Intel 8085	4K bytes of RAM; 16 bytes of PROM (user RAM is expandable to 64K)	Four 8-bit inputs; expandable to eight (16 for the 80); four 4-bit outputs; expandable to 28 (28 for the 80). UART for serial communications; one vectored interrupt line	Systems monitor (includes tape loader and debugger). Assembler, editor	16 status lamps; 16-bit address display; 8-bit processor data bus display; 8-bit instruction or data display	8-bit address or data entry; 14 function switches	Intel 8085: \$150 Intel 8080: \$150
Expander (Western Semiconductor Products Div.)	Intel 8080	256 bytes of RAM; 16 bytes of PROM (user RAM is expandable to 64K)	Teletype interface; 119-600 baud, switch selectable, ten optional modules with four 8-bit I/O (expandable to 12 modules)	Loader, tape puncher (memory writer and debugger are on tape or cassette)	Two status lamps	Three function switches	\$3650
IMP-10 (National Semiconductor Corp.)	Intel 8080	4K, 16-bit words of RAM (expandable to 12K words)	One 16-bit input/output bus; one vectored general interrupt line; one vectored interrupt line (ICL has four vectored interrupts); six control flags; four jump control inputs; teletype and card reader interface. IMP-10L has direct memory access.	Loader for paper tape and card reader; teletype and card reader service routines (assembler, editor, utilities, debuggers are on paper tape or cards.)	16-bit data display; 16-bit address display; 3 status displays	16-bit data, address entry; nine function switches; 11 position selector switch	IMP-10P: \$355 IMP-10L: \$350
IMP-10P (National Semiconductor Corp.)	Intel 8080	4K bytes of RAM (expandable to 12K bytes)	One 8-bit input/output bus; one general interrupt; four control flags; one jump condition input	Loader for paper tape and cards (assembler, debuggers, teletype, and editor routines are on paper tape or cards.)	Same as IMP-10P, L	Same as IMP-10P, L	\$3750
MS-100 (PCS Inc.)	Intel 8080	1K bytes of ROM; 4K bytes of RAM (expandable to 64K bytes of mixed ROM and RAM)	Teletype interface; one 16-bit I/O	Loader and drivers for main control (assembler, debuggers, editor available on tape)	15-bit address and data display; run lamp	15-bit data entry; 12 function switches	\$3995
SS-1, 1A, 1B (Pro-Log Corp.)	Intel 8080	1280 bytes of PROM (expandable to 1K bytes for SS-1A, 1048 bytes for SS-1B); PROM programmer	SS-1 has four 6-bit inputs; five 4-bit outputs; SS-1A and 1B have eight 4-bit I/O lines (card expandable to 128)	None	Chip-on tester has 12 data display lamps; eight instruction lamps; scope sync test point	Chip-on tester has 12 address switches; six function switches	SS-1: \$295 SS-1A: \$315 SS-1B: \$350
SS-2, 2A (Pro-Log Corp.)	Intel 8080	1K words of RAM; 1280 words of PROM (expandable to 1K words of mixed RAM and PROM programmer)	Teletype interface; SS-2 has 28 I/O lines; one interrupt line; SS-2A has 32 input lines and 32 output lines (both are expandable to 128 lines)	Loader, editor; system monitor	Chip-on tester has 16-bit address display; seven status lamps; scope sync test point	Chip-on tester has 16 address switches; three function switches	SS-2: \$300 SS-2A: \$370
COS-14C Micro K-1 (RCA)	RCA COSMAC	1K bytes RAM; 512 bytes PROM; expandable to 2K bytes of mixed RAM and PROM	Teletype interface; UART for serial communications; 8-bit input; 8-bit output; 16-bit general interrupt line; two direct memory access request lines; four jump condition I/O flags; 16 output command lines for use with optional I/O controller cards (12 card slots)	Monitor includes hex loader, terminal I/O (assembler, editor, file system, and full debug capability available on later model)	Run indicator	Four function switches	To be announced
TLC-12 Computer Set (Tech-9)	Toshiba TLC-12 (6-1)	500 words of RAM (expandable to 4K words of mixed RAM and PROM)	Teletype interface	Assembler	12-bit address display; 12-bit data display; four status lamps	12-bit address or data entry; 7-position selector switch; three function switches	\$2320 POB Japan

3.6

Microcomputer System Manufacturers

A number of companies offer microprocessor-based systems built around either their own or someone else's chips. These systems are useful in the developmental and prototype stage; moreover, some of these systems include proprietary software not available from the chip manufacturer. Table 3-1 (Falk, 1974) lists manufacturers and characteristics of a number of available microcomputer development systems.

Table 3-2 shows the relative speed and memory requirements of some of the more widely available processors when running typical small tasks. These numbers are plotted in Figure 8.

	Elec- tronic Arrays	Intel Corp 8008	Intel Corp 8080	Mostek Corp 5065	Motorola Semi M6800	Nat'l Semi IMP-8	RCA Corp Cosmac	Rock- well Int'l PPS-8	Scien- tific Micro Sys	Sig- netics Corp 2650	WDC Macro Level	WDC Micro Level
--	---------------------------	-----------------------	-----------------------	------------------------	---------------------------	------------------------	-----------------------	---------------------------------	---------------------------------	--------------------------------	-----------------------	-----------------------

BLOCK DATA MOVEMENT:

Bytes of instruction	13	34	18	40	15	40	22	43	60	10	10	34
Set-Up Time	4	170	13.5	75	8	75	60	144	2.1	4.8	7.8	3.3
Move Time/Char	24	184	23.5	89	20	91	36	16	6.9	26.4	6.0	3.0

SERVICING AN INTERRUPT:

Bytes of instruction	20	51	8	--	2	26	15	12	68	13	14	42
Service Time	44	1076	42	--	22	113	72	88	10.2	52.8	19.5	9.0

ADD OF "N"

DECIMAL DIGITS AND STORE:

Bytes of instruction	8	70	22	30	17	71	79	16	68	17	16	46
Set-Up Time	10	168	17.5	7.1	7	15	114	40	1.2	7.2	10.2	4.2
Add Time/Byte	9	1008	29	147	28	234	216	24	9.0	50.4	11.1	5.1

SEARCH FOR CHARACTER STRING:

Bytes of instruction	23	30	21	32	22	22	23	20	62	16	24	42
Set-Up Time	10	32	5	48.6	3	20	36	40	2.4	4.8	8.7	4.2
Search Time/Char	35	360	29.2	87	29	40	48	32	4.2	40	15	4.5

MONITORS & DATA CHANNELS:

Bytes of instruction	39	43	34	40	30	34	28	36	58	30	8	20
Set-Up Time	12	64	8.5	42.9	--	10	24	28	0.9	--	--	--
Through-Put	<u>77</u>	<u>704</u>	<u>71.1</u>	<u>148.7</u>	<u>61</u>	<u>146</u>	<u>84</u>	<u>84</u>	<u>7.2</u>	<u>98.4</u>	<u>9.3</u>	<u>3.3</u>

TOTAL:

Bytes of Instruction	103	228	103	142	86	194	167	127	316	86	72	184
Total Program Execution Time (usec)	225	3766	249.3	645.3	178	744	690	496	44.1	284.8	87.6	36.6

NOTES: Mostek has 3 sets of Reg and has no Interrupt housekeeping. Signetics, Motorola, and WDC have Interrupt Polling Schemes to monitor activities.

Table 3-2

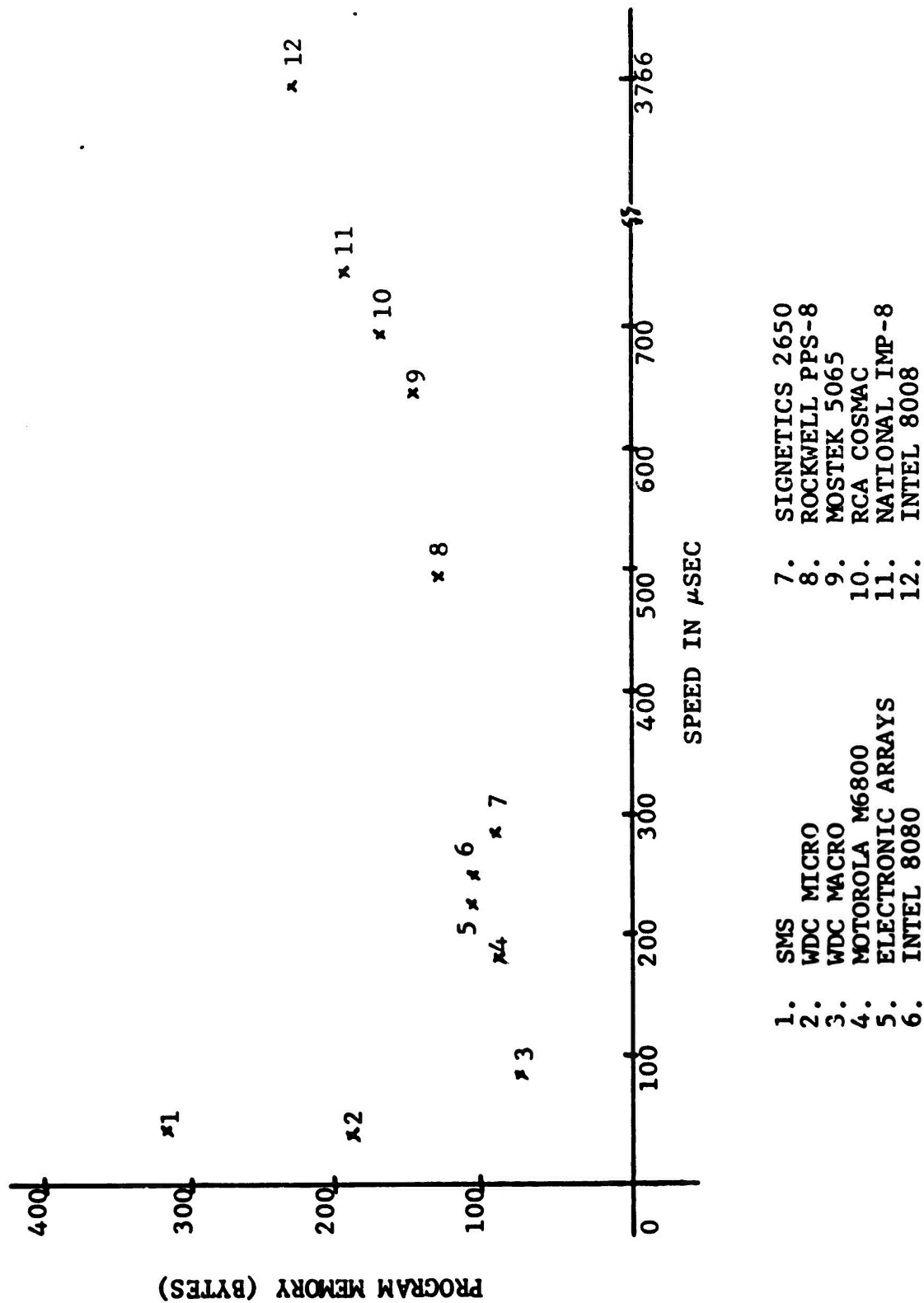

- | | |
|----------------------|--------------------|
| 1. SMS | 7. SIGNETICS 2650 |
| 2. WDC MICRO | 8. ROCKWELL PPS-8 |
| 3. WDC MACRO | 9. MOSTEK 5065 |
| 4. MOTOROLA M6800 | 10. RCA COSMAC |
| 5. ELECTRONIC ARRAYS | 11. NATIONAL IMP-8 |
| 6. INTEL 8080 | 12. INTEL 8008 |

Figure 8

4.0 COMPUTER FUNCTIONS

4.1 Introduction

This chapter describes the major functions which the computer must perform including both computation and receiver control. The topic of recursive filters for position estimation and its implications for both computer selection and system performance is discussed. Of particular interest are alternate forms which are less sensitive to computer word lengths and thus are more suitable for implementation in small computers. Other topics include estimates of computation time as a function of the number of filter states, causes of filter divergence and initialization procedures.

The above topics are motivated by the need to use small microprocessors in the manpack in order to meet size, weight, power consumption and cost goals.

4.2 Receiver-Computer Interactions

In addition to its computational functions the manpack computer will also control and sequence receiver operations associated with both initial satellite acquisition and housekeeping. To illustrate some of the tasks which the computer must perform the sequence of operations required to utilize the P-code are listed below:

1. Select constellation based on approximate location and time using Keplerian Orbit model and GDOP calculation.
2. Compute expected doppler and set doppler offset into receiver.

3. Select proper code, load into receiver code generator and step generator in one-half chip increments until lock is achieved or some predetermined length of time passes without lock being obtained. In the latter case return to the error-handling routine.
4. When lock is achieved locate the sync and Hand-Over-Word (HOW) in the data.
5. Using the sync and HOW, acquire the P-code and measure the pseudorange.
6. Demodulate the P-code data for fine orbit position determination.

Steps 2-6 are performed in parallel for 4-channel receiver and sequentially for sequential receiver.

7. Using recursive filtering compute the receiver position and clock-bias based on the fine orbit model with corrections for ionospheric and tropospheric delay (using L1/L2 corrections or models).
8. Periodically check constellation for GDOP and elevation angle. If better constellation becomes available change to new constellation. If constellation deteriorates badly and no new constellation is available go to error-handling routine.
9. Transform receiver position into UTM coordinates as required.

Although some of the operations listed above could be done either in software or hardware they have been partitioned such that the computer performs those operations which either require considerable computation or would require special purpose hardware with a low utilization. These tasks include filtering, constellation selection, doppler prediction, pseudorange and pseudo-doppler calculation and data demodulation.

Hardware is most useful for implementing high speed or repetitive tasks such as code generation, acquisition and tracking. System time also should be maintained with hardware. Either software or hardware could be used to locate the sync and HOW. In any case the computer must have data such as the coarse orbital model parameters, code words for each satellite and ionospheric correction model parameters stored in read-only-memory (ROM) to prevent loss of this data when the equipment is turned off.

Because of the number of computer-receiver interactions during the initial acquisition process the manpack processor must have an efficient interrupt-handling scheme. Polling, where the computer continually loops through a segment of code to check the status of external hardware, would waste computer capability in this application.

One real advantage of incorporating as much of the receiver control as feasible in software is that it becomes possible to modify receiver operation without extensive hardware modifications, which may be particularly useful in early-generation receivers. In addition, the smaller amount of hardware reduces initial cost and power consumption, increases reliability and simplifies maintenance. From a systems point-of-view these benefits could be well worth any reduction in speed.

4.3 User Position Determination

In order for the user to compute position, the receiver must first accurately measure the corrected pseudorange to each spacecraft. The pseudorange measurement in conjunction with the accurately known spacecraft orbital position allows the computation of position; however, system time must also be accurately known in order to do the precise orbit determination.

This time information (user clock bias) can be obtained as one of the solve-variables in a recursive estimation procedure. The accurate system time thereby derived is used in a precision orbit position model along with the orbit model parameters transmitted as data.

4.3.1 Recursive Filtering

Recursive filtering is used extensively in navigation applications since it allows real-time position updating by incorporating new measurement data while at the same time reducing the error by filtering. The best known of these techniques is Kalman filtering and its computational variations such as the Joseph measurement incorporation algorithm and the Potter square root filter. These filters are of great interest because they are capable of providing the minimum mean square linear estimate of a set of parameters corrupted by noise. The equations for these filters are presented in Appendix C.

Although the Kalman formulation is efficient computationally, if the problem is ill-conditioned the measurement incorporation algorithm of the standard Kalman filter is very sensitive to computer word length round-off. The Potter square-root design has approximately twice the precision of the Kalman form for ill-conditioned problems and is thus more stable (Kaminski, 1971); however, this increase in stability is obtained at the expense of significantly greater computation time. Carlson (Carlson 1973) has developed a modified form of the square root filter which increases computation speed to approximately that of the standard Kalman filter in low-order designs while retaining the numerical stability of the square root implementation. Carlson's paper contains tables which compare the number and type of arithmetic operations needed for measurement incorporation and time update steps in these different filter implementations. These tables are reproduced as Tables 4-2 and 4-3.

Table 4.2 Number of arithmetic operations for one measurement incorporation step

Arithmetic operation	New square root	Potter square root	Kalman conventional	Joseph conventional
Adds	$m(\frac{1}{2}n^2 + \frac{1}{2}n)$	$m(3n^2 + 1)$	$m(\frac{1}{2}n^2 + \frac{1}{2}n)$	$\frac{1}{2}n^3 - 2n^2 + \frac{1}{2}n + \frac{1}{2}m^3 + m^2(\frac{1}{2}n - 1) + m(\frac{1}{2}n^2 + \frac{1}{2})$
Multiplies	$m(2n^2 + 4n)$	$m(3n^2 + 3n + 1)$	$m(\frac{1}{2}n^2 + \frac{1}{2}n)$	$\frac{1}{2}n^3 + \frac{1}{2}n^2 + \frac{1}{2}m^3 + m^2(\frac{1}{2}n + \frac{1}{2}) + m(\frac{1}{2}n^2 + 3n - 1)$
Divides	$2mn$	$2m$	m	$2m$
Square roots	mn	m	0	m
Total operations	$m(\frac{1}{2}n^2 + \frac{1}{2}n)$	$m(6n^2 + 3n + 5)$	$m(3n^2 + 5n + 1)$	$3n^3 - \frac{1}{2}n^2 + \frac{1}{2}n + m^3 + m^2(3n + \frac{1}{2}) + m(5n^2 + 3n + \frac{1}{2})$

Table 4.3 Number of arithmetic operation for one time update step

Arithmetic operation	New square root		Potter square root		Kalman and Joseph conventional
	RSS	Householder	RSS	Householder	
Adds	$\frac{1}{2}n_1^3 + \frac{1}{2}n_1^2 - \frac{1}{2}n_1 + \frac{1}{2}n_2^3 + n_2^2(n_1 + \frac{1}{2}) + \frac{1}{2}n_2(n_1^2 - n_1 + \frac{1}{2}) + \frac{1}{2}p^3 + \frac{1}{2}p$	$\frac{1}{2}n_1^3 - \frac{1}{2}n_1 + \frac{1}{2}n_2^3 + n_2^2(n_1^2 - n_1 + \frac{1}{2}) + \frac{1}{2}p^3 + \frac{1}{2}p$	$\frac{1}{2}n_1^3 - \frac{1}{2}n_1 + \frac{1}{2}n_2^3 + n_2^2(2n_1 + 1) + n_2(3n_1^2 + \frac{1}{2}) + p$	$\frac{1}{2}n_1^3 - n_1 + \frac{1}{2}n_2^3 + n_2^2(2n_1 + 1) + n_2(3n_1^2 + 1) + \frac{1}{2}p^3 + \frac{1}{2}p^2 + \frac{1}{2}p$	$\frac{1}{2}n_1^3 - \frac{1}{2}n_1 + n_2^3 + n_2^2(n_1^2 + \frac{1}{2}n_1 + \frac{1}{2}) + p$
Multiplies	$\frac{1}{2}n_1^3 + \frac{1}{2}n_1^2 - \frac{1}{2}n_1 + \frac{1}{2}n_2^3 + n_2^2(2n_1 + 3) + \frac{1}{2}n_2(3n_1^2 + 3) + \frac{1}{2}p^3 + p^2 - \frac{1}{2}p$	$\frac{1}{2}n_1^3 + n_1^2 - \frac{1}{2}n_1 + \frac{1}{2}n_2^3 + n_2^2(2n_1 + 3) + \frac{1}{2}n_2(n_1^2 + 3) + \frac{1}{2}p^3 + 2p^2 + \frac{1}{2}p$	$\frac{1}{2}n_1^3 + 2n_1^2 - \frac{1}{2}n_1 + \frac{1}{2}n_2^3 + n_2^2(2n_1 + 3) + n_2(3n_1^2 + \frac{1}{2})$	$\frac{1}{2}n_1^3 + 2n_1^2 + \frac{1}{2}n_1 + \frac{1}{2}n_2^3 + n_2^2(2n_1 + 3) + n_2(3n_1^2 + 4n_1 + \frac{1}{2}) + \frac{1}{2}p^3 + \frac{1}{2}p^2 + \frac{1}{2}p$	$\frac{1}{2}n_1^3 + \frac{1}{2}n_1^2 + \frac{1}{2}n_2^3 + n_2^2(n_1^2 + \frac{1}{2}n_1 + \frac{1}{2})$
Divides	p	p	$n_1 + n_2$	$n_1 + n_2$	n
Square roots	p	p	$n_1 + n_2$	$n_1 + n_2$	0
Total operations	$\frac{1}{2}n_1^3 + 2n_1^2 - \frac{1}{2}n_1 + 2n_2^3 + n_2^2(2n_1^2 - n_1 + \frac{1}{2}) + \frac{1}{2}p^3 + p^2 + \frac{1}{2}p$	$\frac{1}{2}n_1^3 + n_1^2 - \frac{1}{2}n_1 + 2n_2^3 + n_2^2(2n_1^2 - n_1 + \frac{1}{2}) + \frac{1}{2}p^3 + 3p^2 + \frac{1}{2}p$	$\frac{1}{2}n_1^3 + 2n_1^2 - \frac{1}{2}n_1 + \frac{1}{2}n_2^3 + n_2^2(4n_1 + 4) + n_2(6n_1^2 + \frac{1}{2}) + p$	$\frac{1}{2}n_1^3 + 2n_1^2 + \frac{1}{2}n_1 + \frac{1}{2}n_2^3 + n_2^2(4n_1 + 4) + n_2(6n_1^2 + 4n_1 + \frac{1}{2}) + \frac{1}{2}p^3 + 2p^2 + \frac{1}{2}p$	$3n_1^3 + \frac{1}{2}n_1^2 - \frac{1}{2}n_1 + \frac{1}{2}n_2^3 + n_2^2(2n_1^2 + 4n_1 + 5) + p$

$$n n_1 + n_2 = n: n_1 \leq p \leq n$$

In these tables m is the number of simultaneous measurements to be incorporated in each measurement step, n is the number of filter states, n_1 is the number of independent process noises being considered and RSS and Householder refer to alternative techniques for triangularization of the updated covariance square-root matrix. The Householder triangularization requires about one-half the numerical precision of the RSS method but needs appreciably more computation time.

4.3.2 Effect of the Number of Filter States on Processor Design and Filter Performance

Tables 4-2 and 4-3 show that the number of computations rises rapidly as the number of states in the filter increases. For a given processor this increase in the number of required computations causes the minimum time between updates to increase, with the possible result being poorer overall performance since measurements are not being incorporated at as high a rate as perhaps is possible, causing a loss in information. For the moving user, in particular, excessively long intervals between updates will greatly increase the error. Conversely, if a sufficient number of states is not included in the filter model then the filter performance will also be poor and can in fact diverge. Clearly, then, there is an optimum number of filter states based on the user dynamics, noise sources, available computation speed and accuracy, number of measurements and filter algorithm used. Ultimately, candidate filters must be tested in actual equipment or with an accurate simulation which includes computer-dependent effects and all of the sources of error. A covariance analysis is not sufficient since it does not include computational effects. One possible result of failure to test a filter design under conditions that adequately simulate actual use is a design that performs substantially poorer than predicted.

Under some conditions the filter performance error can become so large that the estimates are useless. When this happens the filter is said to have diverged. This behavior is typically caused by a poor model of the error sources which results in a covariance matrix which is too small (and thus a higher gain filter) and does not properly weight the measurements. Divergence may result from one or more of the following:

1. Truncation errors caused by finite word length.
2. Failure to model the noise sources properly, i.e. poor estimates of the state error covariance matrix, the process noise covariance matrix, or the measurement error covariance matrix. Failure to include a significant noise source can be disastrous.
3. Failure to model the process itself properly.
4. Failure to model the measurement process correctly.

Since one of the possible causes of filter divergence is the failure to accurately model or include noise sources it is important that the designer identify all of the significant contributors along with estimates of their magnitudes. These sources include the following:

1. Lack of knowledge of true system time because of drifts in the phase and frequency of the satellite oscillator which are not accurately modeled. Both random and bias errors are present.
2. Inability to measure the pseudorange accurately as a result of propagation delays that are not accounted for by the model. These effects will be increasingly important at low elevation angles, and, unless L1/L2 measurements are made, will contribute both random and bias errors.

3. Errors in measurement of code phase due to the presence of thermal and jamming noise in the receiver and the effect of code resolution. These errors are zero mean.
4. Errors in estimating doppler (if used as part of the filter states) depend on the measurement technique but in general have similar sources as 3.
5. Inability to accurately know the position of the satellite at a given time. Obviously the satellite position (ephemeris) must be known accurately to compute position and user time. Error sources are the satellite position model stored on the satellite and satellite clock errors.
6. Errors in pseudorange and user time bias calculations resulting from drift and noise in the user oscillator.

Most techniques that have been proposed for avoiding filter divergence are somewhat empirical and must be adjusted according to the application. One of these, "over weighting" (Schmidt, 1967) allows a weighting factor that weights the measurements more heavily than the standard filter, thereby preventing computationally small error covariances.

Another weighting technique considered by both Tarn and Zaborsky (Tarn and Zaborsky 1970) and Sorenson (Sorenson etal 1970) is age weighting which exponentially weights older data such that new data is emphasized, thereby overweighting newer data. It has the advantage of being simple to implement with either covariance or information filters by simply replacing the state transition matrix ϕ_k by ϕ_k^* where

$$\phi_k^* = \phi_k \cdot \exp(\beta \Delta_k),$$

$\beta \geq 0$, and Δ_k is the time between stage k and $k+1$. Thus Δ_k is the "time-constant" over which most of the filtering is done.

In general these techniques should only be applied if more straight-forward techniques such as square-root filters fail since they compromise the filter performance if used unnecessarily.

4.3.3 Recursive Filter Computation Estimates

The minimum number of states is application dependent; however to provide a basis for estimating computational requirements three possible classes of users are proposed:

1. Stationary User - filter states are the user oscillator phase and frequency offset plus user position (5 states). Pseudorange (PR) and pseudo-doppler (PD) are measured.
2. Moving User I - filter states are the user oscillator phase and frequency offset plus both user position and velocity (8 states). Both PR and PD measured.
3. Moving User II - the filter states include those of Moving User I with the addition of user acceleration (11 states). Both PR and PD measured.

The number of additions, multiplications, divisions and square roots required to implement filters for each of the above three classes were calculated using the formulas in Tables 4-2 and 4-3. The amount of computation time required for the three classes was estimated by using published average execution times for the Hewlett Packard Model 2116 computer library routines shown in Table 4-4.

Table 4-4

Execution Time for Hewlett Packard 2116
Computer Library Routines (1.6 microsecond cycle time)

Routine Name	Execution Time (Milliseconds)		
	Minimum	Average	Maximum
Floating Point Addition	0.3	0.5	0.9
Floating Point Multiply	0.64	0.7	0.75
Floating Point Divide	1.2	1.3	1.5
Floating Point Square Root	3.94	4.8	6.45

These execution times for the Hewlett Packard 2116 are typical of 16 bit minicomputers and some of the faster microcomputers. These estimates are only approximate since there will be variations resulting from cycle time and architectural differences. These times also assume that the filter is implemented with software floating point computations and that the resulting accuracy of approximately 24 bits including sign is sufficient (floating point numbers are represented by two 16-bit computer words with the exponent and its sign occupying eight bits and the fraction and its sign occupying 24 bits). Inclusion of a hardware floating point processor would greatly increase the filter speed.

The computation requirements and estimated time for one measurement incorporation and one time update for the three classes of users are shown in Tables 4-5 through 4-7. The numbers in parentheses are the times required for each type of arithmetic operation based on Table 4-4. These times do not include the operations required for computing the measurement noise covariance matrix, the measurement gradient matrix or the measurement residuals. It is also assumed (Carlson 1973) that the measurement noise processes are uncorrelated and that measurements are incorporated one at a time, except for the Joseph square root filter. These estimated times do not include overhead time for computing subscripts for matrix

Table 4-5 Computation Requirements for the Stationary User ($n=5$, $m=2$, $p=5$, $n_1=5$, $n_2=0$)

Measurement Incorporation Step

Computation	Filter Type			
	Carlson SR	Potter SR	Kalman	Joseph
Additions	80(0.040)	152(0.076)	90(0.045)	296(0.148)
Multiplications	140(0.182)	182(0.237)	110(0.143)	393(0.511)
Divisions	20(0.014)	4(0.003)	2(0.001)	4(0.003)
Square Roots	10(0.048)	2(0.010)	0	2(0.010)
Total Time (Sec.)	0.284	0.325	0.189	0.671

Time Update Step

Computations	Filter Type			
	Carlson SR W/RSS	Carlson SR W/Householder	Potter SR W/RSS	Potter SR W/Householder
Additions	155(0.078)	210(0.105)	205(0.103)	285(0.143)
Multiplications	205(0.267)	265(0.345)	255(0.332)	315(0.410)
Divisions	5(0.004)	5(0.004)	5(0.004)	5(0.004)
Square Roots	5(0.024)	5(0.024)	5(0.024)	5(0.024)
Total Times (Sec.)	0.372	0.477	0.463	0.580
				0.385

Table 4-6 Computation Requirements for the

Moving User I ($n = 8, m = 2,$

$p = 8, n_1 = 8, n_2 = 0$)

Measurement Incorporation Step

Computation	Filter Type			
	Carlson SR	Potter SR	Kalman	Joseph
Additions	200(0.100)	386(0.193)	216(0.108)	1013(0.507)
Multiplications	320(0.224)	434(0.304)	248(0.174)	1224(0.857)
Divisions	32(0.022)	4(0.005)	2(0.003)	4(0.005)
Square Roots	<u>16(0.077)</u>	<u>2(0.010)</u>	<u>0</u>	<u>2(0.010)</u>
Total Time (Sec)	0.423	0.512	0.284	1.378

Time Update Step

Computation	Filter Type			
	Carlson SR W/RSS	Carlson SR W/Householder	Potter SR W/RSS	Potter SR W/Householder
Additions	624(0.312)	828(0.414)	848(0.424)	1116(0.558)
Multiplications	752(0.526)	964(0.675)	976(0.683)	1188(0.832)
Divisions	8(0.010)	8(0.010)	8(0.010)	8(0.010)
Square Roots	<u>8(0.010)</u>	<u>8(0.010)</u>	<u>8(0.010)</u>	<u>8(0.010)</u>
Total Time (Sec)	0.887	1.137	1.156	1.438
				Kalman and Joseph
				764(0.382)
				664(0.465)
				0
				0
				0.847

Table 4-7

Computation Requirements for the
Moving User II ($n = 11, m = 2,$
 $p = 11, n_1 = 11, n_2 = 0$)

Measurement Incorporation Step

Computations	Filter Type		
	Carlson SR	Potter SR	Kalman
Additions	374(0.187)	728(0.364)	396(0.198)
Multiplication	572(0.400)	794(0.556)	440(0.308)
Division	44(0.057)	4(0.005)	2(0.003)
Square Roots	<u>22(0.106)</u>	<u>2(0.001)</u>	<u>0</u>
Total Time (Sec)	.750	0.926	0.509
			1.660

Time Update Step

Computations	Filter Type			
	Carlson SR W/RSS	Carlson SR W/Householder	Potter SR W/RSS	Potter SR W/Householder
Additions	1606(0.803)	2112(1.056)	2211(1.106)	2838(1.419)
Multiplications	1848(1.294)	2365(1.656)	2453(1.717)	2970(2.079)
Divisions	11(0.014)	11(0.014)	11(0.014)	11(0.014)
Square Roots	<u>11(0.053)</u>	<u>11(0.053)</u>	<u>11(0.053)</u>	<u>11(0.053)</u>
Total Time (Sec)	2.164	2.779	2.890	3.565
				2.521

operations (which only require the much faster single precision integer arithmetic) nor do they account for possible inefficient code generation by a high level compiler relative to assembly language coding.

Examination of the estimated times for each of the possible user classes shows that the Carlson square-root filter and the Kalman filter are clearly superior. However the better stability of the Carlson square-root filter in conjunction with Householder triangularization make it the recommended technique.

The estimated time for one measurement incorporation plus one filter update for each user class with the Carlson square root filter and Householder triangularization is:

- a. Stationary User - 0.761 seconds
- b. Moving User I - 1.310 seconds
- c. Moving User II - 3.529 seconds

For a complete constellation of four satellites and a four channel receiver these times would be increased by a factor of four.

For the single channel receiver these times must include any additional time for reacquiring the next satellite in the constellation. Whether this process actually results in increased time depends on the relative duration of the measurement interval to the filter measurement incorporation, reacquisition, and filter update time. It is possible to allow the computer to be processing the most recent measurements while the receiver is reacquiring the next satellite and making the next measurement. Whichever process is the longest will set the minimum filter cycle time.

Normally, the receiver is capable of making measurements at a rate in excess of the ability of the filter to incorporate them, particularly in the case of a four-channel receiver. This mismatch means that the filter cannot make use of all of the available information, leading to poor performance. Joglekar (Joglekar, 1973) suggested a technique for incorporating these additional measurements which consists of simply averaging several successive measurements and using the average in the measurement incorporation step. Obviously, the number of measurements that can be handled in this way is limited by the user dynamics although typically 2 to 4 measurements can be averaged. It appears that, at least for the stationary user, measurement averaging can be a useful technique for reducing code-phase measurement errors resulting from thermal noise, jamming and oscillator phase noise since the expected RMS error will decrease as $(N)^{-\frac{1}{2}}$ where N is the number of measurements averaged.

In practice there may be 25 to 50 cycles before the filter estimate has sufficiently small error to be useful. The time required for these cycles must be added to the acquisition time to estimate the length of time before a useful "fix" is obtained. Unless computation speed can be increased by techniques such as a hardware floating-point processor added to the basic microprocessor or more efficient instruction execution, i.e., by microprogramming, it would appear that execution times are marginal except for the stationary user. Microprogramming is preferred over a hardware floating point processor because of the increased power and cost that it would entail. However, if even greater speed is required the hardware processor is the next best choice.

4.3.4 Storage Requirements for Filter Variables

Carlson (Carlson, 1973) gives the program variable storage requirements in Table 4-8. The estimated number of storage

locations for each of the three classes of user based on Table 4-8 is given in Table 4-9. Since these are floating point numbers occupying 32 bits each the number of locations identified in Table 4-8 should be increased by a factor of 2 for a 16 bit memory and by a factor of 4 for an 8 bit memory.

Table 4-8 Program Variable Storage Requirements

Filter formulation	Variable storage words
New square root (RSS)	$n^2+n_1^2+2n_2+3n$
New square root (Housr.)	$n^2+p^2+2n_2+3n$
Potter square root (RSS)	$n^2+n_1^2+2n_2+3n$
Potter square root (Housr.)	$n^2+p^2+2n_2+3n$
Kalman conventional	$n^2+n_1^2+2n_2+3n$
Joseph conventional	$2n^2+2mn+m^2+2n$

Table 4-9 Filter Variable Storage Requirements

	Moving User II	Moving User I	Stationary User
Carlson SR with RSS	275	152	65
Carlson SR with Householder	275	152	65
Potter SR with RSS	275	152	65
Potter SR with Householder	275	152	65
Kalman	275	152	65
Joseph	312	180	84

As can be seen from this table the required amount of storage is the same for all of the various formulations with the exception of the Joseph, which requires about 30% more storage for the stationary user and about 13% for the moving user II. In any case the required number of storage locations is not particularly large. It should be noted, however, that unlike the program storage which will most likely be incorporated in a read-only memory (ROM) the program variable storage must be read-write random-access memory (RAM).

4.3.6 Explicit Navigation Solution

In contrast to recursive (Kalman) filtering of pseudorange measurements, position also may be calculated explicitly.

One technique for explicit calculation (Schmidt, 1972) is relatively simple. The calculation is based, in three dimensions, on finding the focus of a three dimensional conic defined by the four satellites and the measured pseudorange differences. It can be shown that the focus is the user location.

The solution proceeds by selecting three of the satellites and finding the equation of a plane containing the focus. This procedure is repeated for the remaining triads and the resulting set of linear equations solved for the common intersection of planes, which is the focus and hence the user location. The equation for the plane is:

$$\begin{aligned} & (x_1 \Delta_{23} + x_2 \Delta_{31} + x_3 \Delta_{12})x + (y_1 \Delta_{23} + y_2 \Delta_{31} + y_3 \Delta_{12})y \\ & + (z_1 \Delta_{23} + z_2 \Delta_{31} + z_3 \Delta_{12})z \\ & = 1/2 (\Delta_{12} \Delta_{23} \Delta_{31} + a_1^2 \Delta_{23} + a_2^2 \Delta_{31} + a_3^2 \Delta_{12}) \end{aligned}$$

which is of the form $Ax + By + Cz = D$, where Δ_{ij} is the range difference between the i th and j th satellite, and

$A_j^2 = X_j^2 + Y_j^2 + Z_j^2$, where (X_j, Y_j, Z_j) are the coordinates of the j th satellite. Thus

$$\begin{bmatrix} A_1 & B_1 & C_1 \\ A_2 & B_2 & C_2 \\ A_3 & B_3 & C_3 \end{bmatrix} \begin{bmatrix} X \\ Y \\ Z \end{bmatrix} = \begin{bmatrix} D_1 \\ D_2 \\ D_3 \end{bmatrix}$$

and the subscripts identify the triad. It should be noted that four triads can be chosen from four satellites. Since only three triads provide independent solutions, the fourth triad can either be ignored or included via a least-mean-square solution. The latter approach is preferable in that some averaging of error results.

The least-mean-square solution which incorporates all four possible triads is:

$$\begin{bmatrix} X \\ Y \\ Z \end{bmatrix} = \left\{ \begin{bmatrix} A_1 & A_2 & A_3 & A_4 \\ B_1 & B_2 & B_3 & B_4 \\ C_1 & C_2 & C_3 & C_4 \end{bmatrix} \begin{bmatrix} A_1 & B_1 & C_1 \\ A_2 & B_2 & C_2 \\ A_3 & B_3 & C_3 \\ A_4 & B_4 & C_4 \end{bmatrix} \right\}^{-1} \begin{bmatrix} A_1 & A_2 & A_3 & A_4 \\ B_1 & B_2 & B_3 & B_4 \\ C_1 & C_2 & C_3 & C_4 \end{bmatrix} \begin{bmatrix} D_1 \\ D_2 \\ D_3 \\ D_4 \end{bmatrix}$$

If more than four satellites are visible or if additional measurements to the same four satellites are available the above solution can be extended to include the additional measurements. One interesting aspect of the least-squares solution is that the matrix to be inverted is always 3 X 3.

Since this position calculation does not account for the magnitudes of the various error sources and weight them appropriately the error will not be as small as for the optimum linear estimator (Kalman filter). However, if the magnitudes of the bias errors are larger than the random errors the Kalman filter will not perform well. Under these conditions the easily calculated explicit solution considered

above may not be much worse in the case of the stationary user. If the user is in rapid motion then the explicit solutions give poor accuracy.

Explicit solutions may be useful in Kalman filter initialization since they do not require any a priori knowledge nor do they require knowledge of user time bias. These calculations can be iterated with the improved estimates of system time used to improve satellite ephemeris and hence the accuracy of the fix.

BIOGRAPHY

Bellantoni, J. F., and Dodge, K. W., "A Square Root Formation of the Kalman-Schmidt Filter," AlAA Journal, Vol 5, No. 7, July 1967, pp. 1309-1314.

Carlson, Neal A, "Fast Triangular Formulation of the Square Root Filter," AlAA Journal, Vol. 11, No. 9, September 1973, pp. 1259-1265.

Joglekar, Anil N. "Data Compression in Recursive Estimation with Applicatons to Navigation Systems", Department of Aeronautics and Astronautics Stanford University, SUDAAR No. 458, July 1973.

Kaminsky, Paul G., "Square Root Filtering and Smoothing for DISCRETE PROCESSES," Department of Aeronautics and Astronautics, Stanford University, Stanford, California, SUDAAR No. 427, July 1971.

Moffett, J. B. ed, "Program Requirements for Two-Minute Integrated Doppler Satellite Navigation Solution", Applied Physics Laboratory, Johns Hopkins University TG 819-1 (Rev 2), July 1973.

Potter, in Battin, R. H., Astronautical Guidance (McGraw-Hill Book Co., INC., New York, 1963) pp. 338-339.

APPENDIX A

EXAMPLE PRIME ITEM DEVELOPMENT SPECIFICATION

for the

GLOBAL POSITIONING SYSTEM

MANPACK NAVIGATION SET

Type B1

**Stanford Telecommunications, Inc.
1161 San Antonio Road
Mountain View, California 94043**

Other Government Activity

SS-GPS-101B
 SCN 01 Jul 74
 SCN 15 Aug 74

System Specification for the NAVSTAR
 Global Positioning System Phase 1

YEN-74-98
 1 Apr 74

Global Positioning System (GPS)
 Army Mission Requirements

YEN-75-14
 14 Jan 75

GPS Manpack/Vehicular User Equipment
 Test Plan

DMA Technical Report 0002
 1 Jan 74

DoD World Geodetic System
 Conference, 1972

Standards

Federal None

Military

MIL-STD-454D
 31 Aug 73

Standard General Requirements
 for Electronic Equipment

MIL-STD-810B
 15 Nov 67
 Change 4
 21 Sep 70

Environmental Test Methods

MIL-STD-1472A
 15 May 70

Human Engineering Design Criteria for
 Military Systems Equipment & Facilities

MIL-STD-188-100
 15 Nov 72

Common Long Haul and Tactical Communi-
 cation System Technical Standards

Drawings

MH08-00002
 Date TBD

NTS PRN Navigation Assembly/User and
 Monitor System Segments

Other Publications None

2.2 Non-Government Documents None

3.0 Requirements. The manpack set shall be designed to generate position and time data when operated in the GPS signal environment specified in SS-GPS-101. The set shall be designed to satisfy mandatory requirements for size, weight, and continuous operating time while optimizing accuracy, acquisition time, and AJ performance.

3.1 Item Definition. The manpack set shall consist of a single self-contained package which includes all major components shown in Figure I . It shall be possible for an operator to use the set in all its normal operating modes while it is being carried.

3.1.1 Item Diagram. See Figure I .

3.1.2 Interface Definition. Figure II illustrates the required interfaces between the manpack and external equipment.

3.1.2.1 Manpack/Satellite Interface. The Satellite/user interface requirements of ICD MH08-00002-400 apply.

3.1.2.2 Manpack/RF Signal Interface. The manpack shall provide for connection to a GFE RF Signal Generator with characteristics specified in (TBS).

3.1.2.3 Manpack/External Time and Frequency Source. The manpack shall be capable of operation with either internal or external time and frequency source which provides, as a minimum, one pulse per second (1 pps), one kilopulse per second (k lpps), and 5 MHz to the set.

3.1.2.4 Manpack/External Power. The manpack shall be designed to connect to and operate on external power for the purpose of re-charging and/or conserving internal battery power.

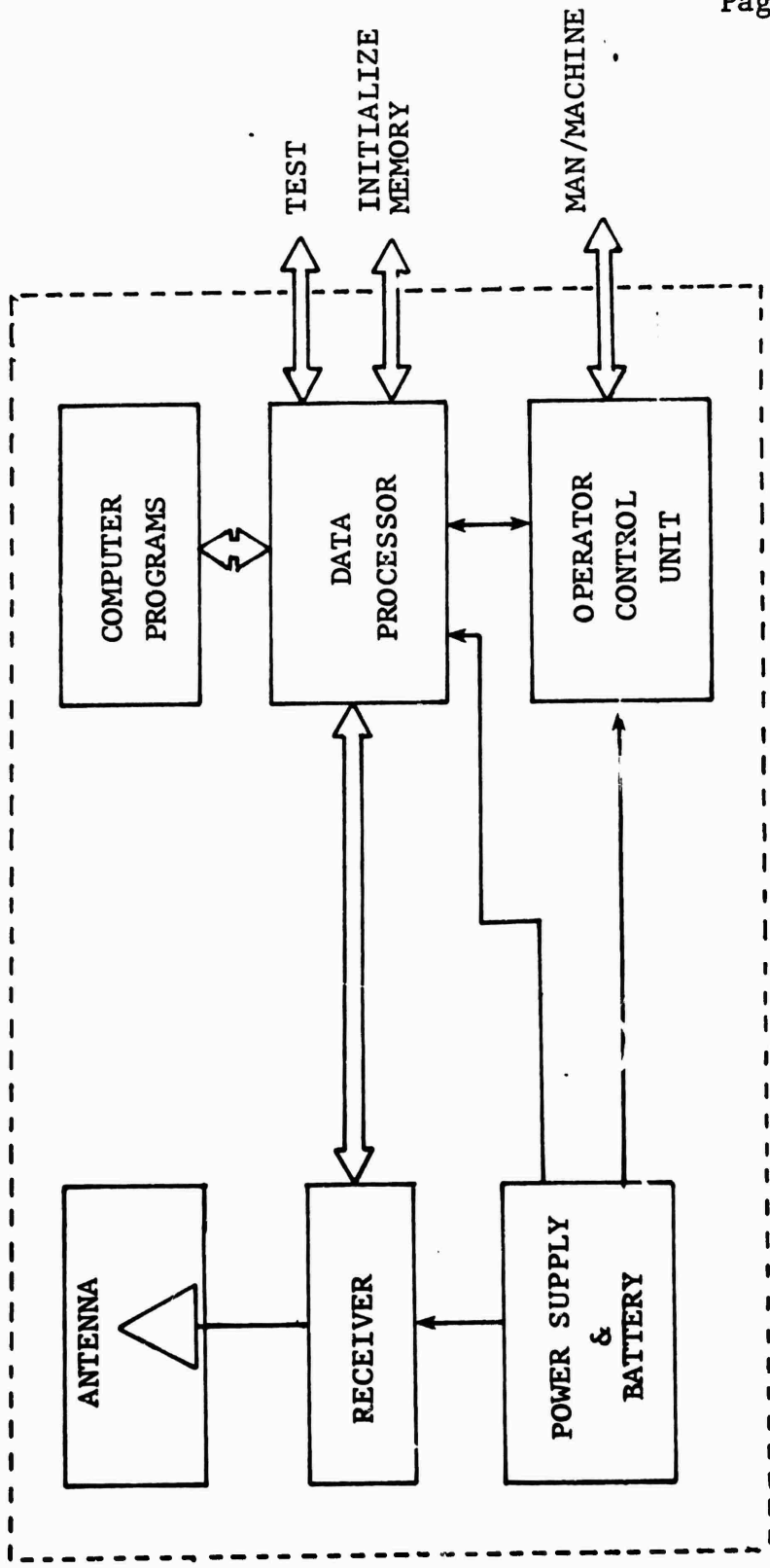

FIGURE I
MANPACK NAVIGATION SET

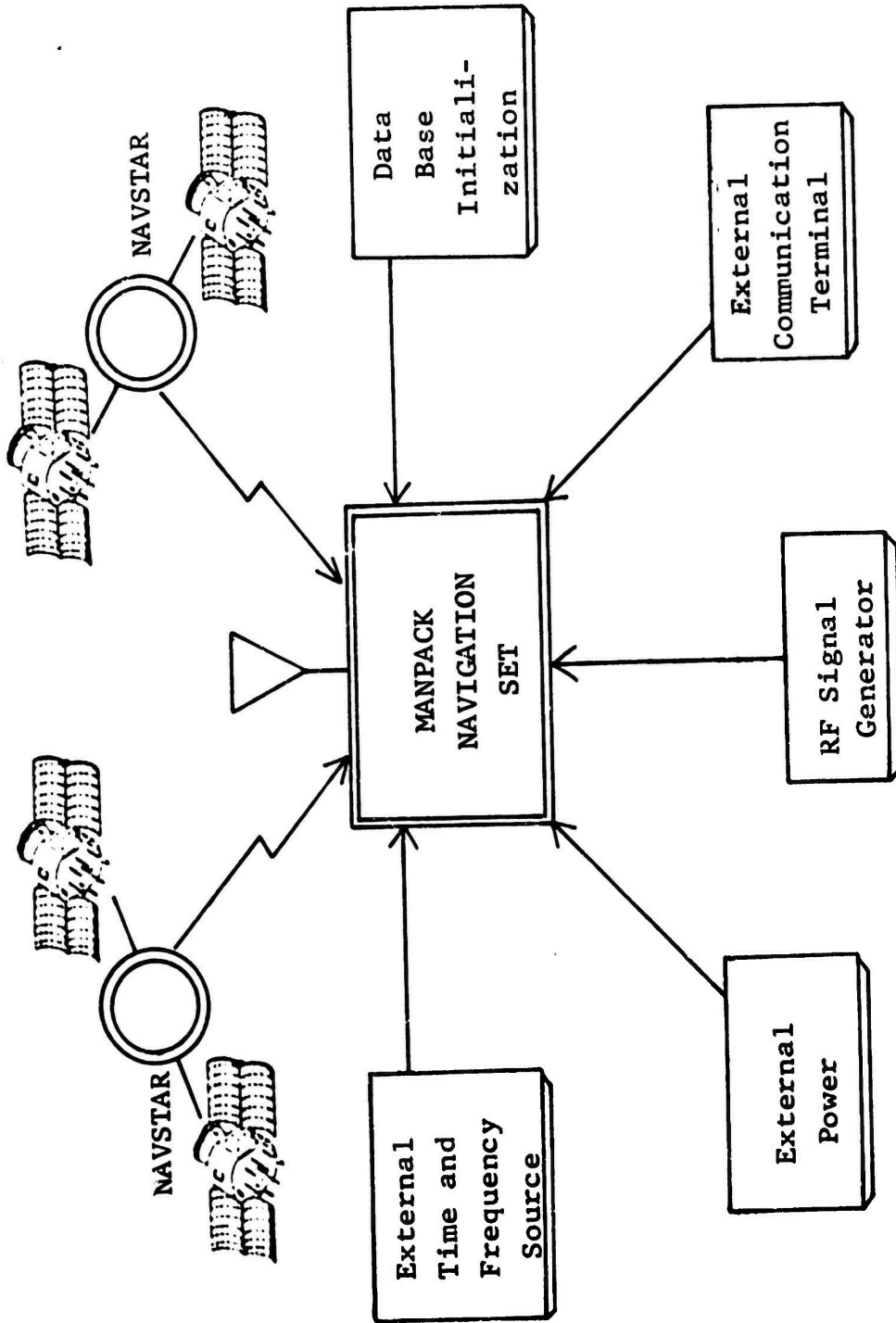

FIGURE II

MANPACK INTERFACES

3.1.2.5 Manpack/Communications Interface. The manpack shall provide a synchronous 2.4 kbps serial data and clock output signal with characteristics as specified in MIL-STD-188C. Digital data shall include position, time, and status in accordance with the formats defined in Section 10.

3.1.2.6 Manpack/Data Base Initialization. The manpack design shall provide for loading initial data base parameters into memory as required to control signal acquisition.

3.1.3 Major Components. Major components of the manpack set are:

- a. Antenna
- b. Receiver
- c. Processor
- d. Computer Programs
- e. Display
- f. Battery Pack.

3.2 Characteristics

3.2.1 Performance. The performance requirement of this section shall be satisfied within the physical constraints of size, and weight, specified in 3.2.2

3.2.1.1 Operating Modes. As a minimum, the set shall operate in the modes shown in Table 1 when receiving L1 C/A channel signals. Mode selection shall be by operator control.

3.2.1.2 Operating Time. The manpack set shall include an internal rechargeable power supply capable of operating for a minimum of 48 hours at 32°F during which an average of 4 fixes per hour are made. Continuous operation for at least 12 hours at 32°F shall be demonstrated.

MODE	SOLUTION PARAMETERS	OPERATOR SPECIFIED PARAMETERS	MINIMUM SIGNALS RECEIVED
I	3-Position 1-Time	None	4
II	2-Position 1-Time	Alt	3
III	2-Position	Alt Time	2
IV	1 - Time	3-Position	1
V	Velocity Bearing Alt	None	4

TABLE 1
OPERATING MODES

3.2.1.3 Navigation Error Performance. Errors contributed to the navigation solution by the manpack for GDOP's of 2 or less under dynamic and signal levels, specified herein, shall not exceed:

- | | |
|-------------------|----------------|
| a. Horizontal CEP | 10 meters |
| b. Vertical PE | 5 meters |
| c. Time (1T) | 30 nanoseconds |

excluding ionospheric errors. The manpack shall be capable of reducing errors due to ionosphere to at least 50% of their nominal values.

3.2.1.4 Response Time Performance. The manpack design shall be capable of the following mutually exclusive response times:

- | | |
|--|-----------------------|
| a. Preparation time prior to mission: | 10 minutes, max. |
| b. Time-to-first-fix: | 5 minutes, max. |
| c. Update rate: | once per minute, max. |
| d. Response to manual request for fix: | 1 second, max. |

3.2.1.5 Dynamics. Performance requirements of this paragraph shall apply under any combination of the following user dynamic conditions:

	<u>Navigation</u>	<u>Tracking</u>
a. Velocity	2 meters/sec	10 meters/sec
b. Acceleration	2.5 "	10 "
c. Jerk	Not applicable	Not applicable

3.2.1.6 Signal Threshold Levels. The manpack shall operate with input signal levels from -130 dbw to threshold. Threshold levels shall be defined as carrier-to-noise density C/No required for the following functions:

<u>Function</u>	<u>C/No</u>
Acquisition Probability .99	33 db-Hz
Nav. Data Error Rate -10^{-5}	30 db-Hz
Carrier/Code Tracking, $\sigma_{\tau} = 0.2$	27 db-Hz

3.2.2 Physical Characteristics

3.2.2.1 Size/Volume. 1000 cu inches, maximum, including battery, antenna, control and display.

3.2.2.2 Weight. 12 pounds, including internal battery, antenna, control and display.

3.2.2.3 Power. Power consumption shall be consistent with 3.2.1.2

3.2.3 Reliability. The manpack shall possess a Mean-Time-Between-Failure (MTBF) of 2000 hours.

3.2.4 Maintainability. The manpack shall be designed for a Mean-Time-To-Repair (MTTR) of 0-10 minutes at the organizational level, 20 minutes direct support, and up to 45 minutes at the general support level.

3.2.5 Environment. (TBS)

3.2.5.1 Temperature. The manpack shall be capable of performing to specification within the temperature range of 32°F to +155°F with an ultimate low temperature requirement of -40°F.

3.2.5.2 Humidity. Manpack/vehicular set performance shall not degrade when subjected to relative humidity of 100% at all ambient air temperatures to 85° and relative humidities corresponding to a dew point of 85°F at all temperatures between 85°F and 120°F, and low relative humidity of 5% at 120°F.

3.2.5.3 Elevation.

- a. Operating 3,000 meters min. (~10,000 feet)
- b. Non-operating 15,000 meters. min. (~50,000 feet)

3.2.5.4 Rain/Immersion.

3.2.5.5 Shock, Bench Handling.

3.2.5.6 Vibration. The equipment shall be capable of specified performance when mounted on either wheeled or tracked vehicles. To meet this requirement, the equipment may be designed to operate either with or without vibration isolators.

3.2.5.7 Orientation. Excepting antenna effects, performance of the manpack shall not be degraded as a result of any orientation.

3.2.5.8 Nuclear Hardening. The ultimate manpack/vehicular set shall meet the nuclear vulnerability/survivability criteria as set forth in YEN-74-98.

3.3 Design and Construction.

3.3.1 Materials, Parts and Processes. Materials, parts and processes used in construction of the equipment shall conform where practical to military standard - consistent with achieving reliable performance under the environmental conditions 3.2.5.

3.3.2 Electromagnetic Radiation. In order to avoid undesirable interference effects on other colocated communications - electronics, the equipment shall be designed to minimize electromagnetic radiation in the frequency range of 10 KHz to 12.6 GHz.

3.3 Identification and Marking.

3.3.3.1 Finish. Final paint shall be lusterless green olive drab as approved by the procuring activity.

3.3.4 Workmanship. The equipment shall be manufactured and assembled in accordance with requirement 9 of MIL-STD-454.

3.3.5 Interchangeability. Parts, modules, etc., shall be interchangeable with similar parts, modules, etc., from another set.

3.3.6 Safety. The equipment shall be designed to preclude safety hazards in accordance with the provisions of MIL-STD-454 Requirement.

1. All corners and edges shall be rounded or rolled and the battery compartment shall provide for gas pressure relief, as required.

3.3.7 Human Performance/Engineering. Principles of Human Engineering in accordance with MIL-STD-1472A shall be applied.

3.4 Documentation (TBS)

3.5 Logistics (TBS)

3.6 Personnel and Training (TBS)

3.7 Major Component Characteristics. The manpack set shall receive the navigation signals transmitted by the GPS transmitters and provide the user with three-dimensional position and time information. To accomplish this, for purposes of description, the manpack set may be considered as consisting of six major functional elements - an antenna assembly, receiver assembly, processor, computer programs, display unit, battery pack, and interface adapters.

3.7.1 Antenna Assembly. The antenna assembly shall consist of the antenna, transmission lines, filters, etc., required to direct the available GPS signals to the rf input of the receiver assembly.

3.7.1.1 Frequency Band. 1.558 GHz to 1.592 GHz.

3.7.1.2 Polarization. RHCP

3.7.1.3 Gain. Gain shall exceed -1 dbi over 90% of hemisphere above 5 degrees elevation.

3.7.1.4 Antenna Assembly. The manpack set shall contain an internal antenna assembly as an integral part of the package. Provisions shall be made for attachment of a remote external antenna.

3.7.2 Receiver Assembly. The receiver assembly shall accept and operate on the output of the antenna assembly. In turn, the receiver outputs the required pseudo-range, pseudo-range rate, and system data extracted from navigation signals to the data processor/computer via appropriate interface circuitry. Each receiver shall accept data from the data processor/computer as required to acquire and track with the GPS signals.

3.7.3 Data Processor/Computer Software. The data processor/computer software accepts and processes the outputs of the receiver assembly and control/display units using appropriate hardware, software, and interfaces and outputs the proper quantity, quality, and form of data required by the remaining elements to support the operations of the set. As a minimum, the data processor/computer software shall perform the following functions:

a. Determine and use the set of GPS transmitters from those available that will provide best user position and/or navigation performance on a continual basis.

b. Provide navigation signal acquisition and tracking-aiding data to the receiver.

c. Accept control commands from the control/display unit and provide for altering the processing of computer programs or other equipment functions as required.

d. Convert the system data and pseudo-range/range-rate measurements into three-dimensional position (UTM/UPS, WGS-72 or local datum) and time.

e. Provide for go/no-go and self-test functions to the maximum extent practical.

f. Compute and output to the Control/Display on command:

(1) Present position

(2) Position of selected rendezvous point

(3) Azimuth to selected rendezvous point with reference to true North

(4) Distance to selected rendezvous point

(5) Time-of-day (day-of-week, hour-min-sec)

g. Provide as a continuous output to the control/display, the number of GPS transmitters being tracked.

h. Compute and output on command the CEP/PE of position, based on, for example, a best estimate of range error and GDOP.

3.7.4 Control/Display Unit. As a minimum, the control/display unit shall provide for manual input and display output functions including, but not limited to the following:

a. Allow the operator to manually input his approximate position, time, current altitude, etc., as needed for processing in accordance with 3.4.3.

b. Allow the operator to manually input up to (TBD) rendezvous coordinates.

c. Allow the operator to display position and time information either continuously or on command at his option.

d. On command, display selected rendezvous locations.

e. On command, display azimuth to selected rendezvous locations, with reference to true North.

f. On command, display distance to selected rendezvous points.

g. On command, display the number of GPS transmitters being tracked.

h. On command, display the CEP/PE of position in meters.

i. Display. A control/display shall be provided as an input/output facility for the operator. As a minimum, it shall permit day/night viewing of an alpha-numeric display of worldwide horizontal position in either 12-character UTM/UPS, or in WGS or local datum LAT/LONG coordinates, plus 4-digit altitude in meters relative to mean sea level and system time or local standard time at the option of the user.

j. Warning Lights. Warning lights shall be provided to alter the operator to undesirable operating conditions. These may include, for example, loss of carrier or code track for each satellite, large GDOP, poor data threshold and large time bias. Where such lights are provided, they shall be normally off, automatically activated, and shall blink when activated.

3.7.5 Battery Pack. The manpack will be powered by a military standard 12 volt or 24 volt battery pack (such as the NICAD Types 88585, 88590, or Lithium Types 8A5585, 8A5590 all of which are now under development). To this end, the contractor shall provide designs compatible with the use of a battery assigned by the Power Sources Technical Area, ECOM. Specific battery assignment shall be obtained by submitting AMC Form 2033-R through the contracting officer to the Power Source Technical Area, ATTN: AMSEL-TL-P, Fort Monmouth, N.J. 07703. The design shall permit rapid replacement of the battery pack, and/or recharging from an external source. Reverse polarity protection shall be included in the external power interface.

3.7.6 Interface Adapter. The manpack design shall provide for the following:

a. Communication. In order to demonstrate transmission of position location and time data, a digital output signal shall be provided at 2.4 Kbps to modulate the AN/PRC-25 or -77 radio set.

b. Test Output. Consistent with his design, the contractor shall provide outputs useful for troubleshooting and/or performance monitoring/recording via a single multi-pin connector. These outputs may include, but are not limited to, such parameters as key voltages, key waveforms, pseudo range/range-rate information, satellite data, and position and time data.

c. Cables/Connectors. Both rf and power cables shall be provided to interconnect with a remote antenna or power source as required.

d. Vehicle Adapter Unit. A vehicle adapter unit shall be provided to achieve the required electrical and mechanical interface associated with both wheeled and track vehicle use.

e. Rack Adapter Unit. An adapter unit shall be provided to permit mounting the manpack in a standard 19" equipment rack.

4.0 Quality Assurance Provisions (TBD)

5.0 Preparation for Delivery.

5.1 Preservation and Packaging for Domestic Shipment. The equipment shall be preserved and packaged for mechanical and physical protection in accordance with best commercial practice. The equipment shall be adequately cushioned, blocked, and braced, using suitable materials and containers as required to afford maximum protection from the hazards normally encountered in storage and transit.

5.2 Packing for Domestic Shipment. The shipment, packaged as described in 5.1, shall be packed in substantial commercial containers of the type, size, and kind commonly used for the purpose in such a manner as to afford maximum protection from normal hazards of handling and transportation and to insure safe delivery and acceptance at the designated point.

6.0 Notes.

APPENDIX B

NOTES ON BATTERY CHOICE FOR MAN-PACK EQUIPMENT

Basic Types

All batteries can be classified into one or the other of two basic types:

1. Primary - Non-rechargeable - typical examples:
Carbon-Zinc, Mercury, Silver Oxide, Lithium, Alkaline, etc.*
*Some types of Alkaline batteries can be recharged 20 to 75 times but successful recycling requires care regarding overcharging and previous battery charge state.
2. Secondary - Rechargeable - typical examples:
Nickel-cadmium, Lead Acid, some Alkaline types, etc.

Because of requirements related to portable military field equipment, low energy density primary batteries can be ruled out as a feasible choice. Mercury batteries, while possessing good energy density characteristics, are not suitable for operation at temperatures much below 0°C and therefore also are not a feasible choice.

Lithium batteries have an extremely high energy density (highest of any primary or secondary type), very good temperature characteristics and long shelf life. Because of these desirable characteristics, Lithium primary batteries warrant further consideration and are included in the following discussion along with suitable secondary battery types.

The rechargeable Alkaline battery as mentioned above is limited to relatively few recharge cycles and further limited by over-charge/damage possibilities, therefore is not considered suitable for this application.

The table summarizes the characteristics of Lithium, NICAD and Lead Acid (gelled electrolyte) batteries, along with other factors considered important in selecting a power source for portable military field equipment.

Note: A sealed wet lead acid battery is now available.
(Gates Rubber)

CHARACTERISTIC	LITHIUM (Primary Battery)	NICAD (Sealed)
Energy Density (W Hrs/Lb.)	≈150	≈15
Nominal Cell Voltage (v)	2.8 v	1.2 v
Shelf Half-Life (at +25°C)	>5 years	≈2 months
Temperature Range		
Store	-60° to +74°C	-40° to +50°C
Operate	" "	-20° to +40°C (1)
Discharge Curve (to 90% disch)	---	Similar
Recharge		
Technique	None	Const. current (2)
Time (0 to 90% A Hr Rating)	--	16 hours
Life (# of cycles)	--	500 - 2000 cycle
Precautions	--	Avoid low temp c
Multiple Cell Operation		
Series (Recom. Max)	No Restriction	≤8 cells (9.6 v)
Parallel (Recom. Max)	No Restriction	Not recommended
Maintenance (Bet. Replacement)	-----	None
Mechanical		
Ruggedness	-----	Similar
Package Style	Cylinder cells & ?	Cylinder cells (3)
Mounting Position	-----	Any (4)
State of Technology	New - much dev. work in process	>15 years; Fast
Availability	1 - 2 sources - more on way	>5 sources
Cost (\$/100 W hr. Cap.)	<\$20 - downward future trend	≈\$100 + packagi

B-3

- (1) NICAD cannot be recharged below +5°C; also H₂ & O₂ will be released if attempt
- (2) Don't know what recharge characteristic is at low temperature (probably falls temperature storage limit for discharged Lead Acid.
- (3) Fast charge techniques are possible but are more complex and subject to other
- (4) H₂ & O₂ is released during charge (starting at ≈50% charge) at a rate of ≈8 i
- (5) Multiple cell NICAD should be factory-custom furnished (cells must be matched

LITHIUM Primary Battery)	NICAD (Sealed Cell)	LEAD/ANTIMONY (Gelled Electy)(Sealed Cell)
	≈15 1.2 v ≈2 months -40° to +50°C -20° to +40°C (1)	≈15 2 v ≈16 months -60° to +60° (2) -60 to +60°
	Similar Const. current ($\leq \frac{A \text{ Hr Rate}}{10}$) (3) (1) 16 hours 500 - 2000 cycles Avoid low temp charging (1) ≤8 cells (9.6 v) recommended (5) Not recommended	(3) (4) Const. Voltage (current limited) 16 hours 200 - 500 cycles Gassing (4) Available in 2, 4, 6, & 12 v packs - no restriction on series or parallel
	None	
s & ?	Similar Cylinder cells (5) Any (1)?	Rect. Packs (4)
work in process - more on way and future trend	>15 years; Fast charge recent >5 sources ≈\$100 + packaging - stable	>2 years - some dev. work in process >2 sources - may be more on way ≈\$30 - slight downward trend

so Hz & Oz will be released if attempted.

is at low temperature (probably falls off fast below -20°C. Also don't know low Lead Acid.

are more complex and subject to other problems.

ing at ≈50% charge) at a rate of ≈8 in³ Hz/Hr/100 W hr. capacity. Requires venting.

ustom furnished (cells must be matched to minimize cell reversal problems).

APPENDIX C

A.1 Recursive Filter Equations

The solution to the discrete linear filtering problem with recursive estimation given by Kalman [Kalman, 1960] assumed that the evolution of a n-dimensional linear multistage process, X_K , as a function of time, t_K , could be described as

$$X_K = \phi_K X_{K-1} + W_K$$

where ϕ_K is the state transition matrix between time t_K and t_{K-1} . ϕ_K has dimensions of $n \times n$. W_K represents the process noise originating in $p \leq n$ sources with zero mean and a known $n \times n$ covariance matrix, Q_K , with rank p . Kalman showed that given a measurement set consisting of m measurements, Z_K , taken at time t_K , the minimum mean square linear estimate of X_K , \hat{X}_K , can be obtained via a recursive calculation.

The solution proceeds between time t_{K-1} and t_K as follows:

- 1) An estimate of the new state at time t_K based on the t_{K-1} is made.

$$\hat{X}_K = \phi_K \hat{X}_{K-1}$$

- 2) The covariance at time t_K is estimated as

$$P = \phi_K P_{K-1} \phi_K^T + Q_K$$

- 3) The filter gain K_K , is calculated as

$$K_K = P_K H_K^T (H_K P_K H_K^T + R_K)^{-1}$$

where H_K is assumed to be a known $m \times n$ measurement gradient matrix (the estimated direction cosines for pseudo range measurements) and R_K is the covariance matrix of the measurement noise ($m \times m$) which is assumed to be uncorrelated with X_K).

- 4) The measurement set, Z_K , consisting of m measurements is used to give an improved estimate of \hat{X}_K , \hat{X}'_K , where

$$\hat{X}'_K = \hat{X}_K + K_K (Z_K - H_K \hat{X}_K)$$

- 5) The covariance of X_K is improved by

$$P'_K = P_K - K_K H_K P_K$$

A major problem with the standard Kalman is that the matrix subtraction involved in the covariance calculation in Step 5 can result in a matrix P'_K which is computationally non-positive with resulting divergence of the filter. The Joseph form of the Kalman filter modifies the covariance calculation by using a less sensitive quadratic form

$$P'_K = (I - KH_K) P_K (I - KH_K)^T + KR_K K^T$$

However the Joseph form requires a considerably larger number of computations.

Square root filters were proposed as a computationally more efficient way to guarantee that P'_K is non-negative definite by keeping the covariance matrix in a "square-root" form where the square-root, S_K can be obtained by Cholesky decomposition of P_K . The original form proposed by Potter (Battin 1964) incorporated measurements one at a time as scalars. The

covariance update is given by a root-sum-square (RSS) procedure

$$S_K = (W_K W_K^T + Q_K)^{\frac{1}{2}}$$

where $W_K = \Phi_K S_{K-1}$

Alternatively the matrix S_K can be generated via a Householder triangularization procedure (Kaminski 1971) which is less sensitive to computer word length round-off effects at the expense of more computation time. Kaminski showed that in ill-conditioned problems square-root filters yield a factor of two more precision.

Carlson (Carlson, 1973) proposed a modification to the Potter form which maintains S_K in triangular form. Thus in the calculation of W_K only the elements in the upper triangular part of S_K must be considered, reducing the computation by one-half. Carlson also gives a recursive calculation for S_K that does not require matrix multiplication.

One useful byproduct of maintaining S_K in upper triangular form is that a simple test for singularity is possible since S_K will be singular if one or more of its diagonal elements are zero. Carlson shows that all that is necessary to prevent singularity is to require that all of the diagonal elements of S_K be greater than the maximum round-off error.

The purpose of this package is to determine which satellites are visible to the user at a particular time and location and to provide the constellation selection package with direction cosines (and coarse ranges). In this computation a simple circular orbit and a uniform gravitational field is assumed. Using orbital parameters for each of the satellites previously stored in the computer and the current time the set of satellites available to the user can be found by a binary tree search. The direction cosines to each of the visible satellites is passed to the constellation selection package.

The program proceeds in five steps:

1. Compute the inertial XYZ coordinates of a candidate spacecraft.
2. Transform the satellite coordinates into earth fixed coordinates.
3. Transform the earth-fixed coordinates into topocentric coordinates using the estimated user latitude and longitude.
4. Compute direction cosine and elevation angle.
5. Compute GDOP.

A.2.1

Satellite Motion in Orbital Plane

Kepler's equation is a transcendental equation in $E(t)$, the eccentric anomaly, given by

$$\frac{2\pi}{P} (t - t_p) = E(t) = e \sin E(t).$$

where P = period of satellite

$$\begin{aligned} t_p &= \text{time of pericenter in system time} \\ e &= \text{orbital eccentricity} \\ t &= \text{system time} \end{aligned}$$

The first step in the problem of finding the satellite position in user coordinate is to write coordinates of the satellite in an earth-centered inertial system (U, V, W) where U is defined as the unit vector in the direction of intersection of the orbital and equatorial plane, W is the unit vector perpendicular to the orbit plane and V completes the right-hand system.

The position of the satellite in the U, V, W system is given by

$$U = a(\cos E(t) \cos \omega - a(1-E^2)^{\frac{1}{2}} \sin E(t) \sin \omega$$

$$V = a(\cos E(t) \sin \omega + a(1-E^2)^{\frac{1}{2}} \sin E(t) \cos \omega$$

$$W = W(t) \text{ (allows for any out of plane motion),}$$

where a is the length of the semi-major axis and ω is the argument of the pericenter.

For the special case of the circular orbit the eccentricity is equal to zero and the eccentric anomaly is given by

$$E(t) = \frac{2\pi}{P} (t-t_p), \text{ circular orbit}$$

where t_p , the time of pericenter passage, is interpreted as the time of equatorial plane passage since in the case of circular

orbits t_p is undefined. Defining t_p in this manner allows ω to be taken as zero.

However, for a circular orbit lying in the equatorial plane (corresponding to $i = 0$) the above definition of t_p must be further modified since the ascending node is no longer defined. For this case it is convenient to take t_p as the time that the satellite orbit intersects the vernal equinox, which allows Ω_0 to be set equal to zero. Alternately, t_p can be any convenient time and Ω_0 is the angle between the satellite and the vernal equinox at t_p .

Because the simple Keplerian model does not account for the non-uniform gravitational field of the earth and the perturbing forces of the moon, sun and other planets over a period of time the error between the actual and predicted satellite position will gradually increase until acquisition becomes difficult because of doppler prediction error as well as possibly searching for a satellite that is erroneously assumed to be visible. The orbit model parameters must be updated sufficiently often to prevent this occurrence either as operator or satellite data inputs or by having a very large data table stored in the user's computer.

To provide the accuracy for navigation, as opposed to acquisition, requires several orders of magnitude more precision in the ability to predict satellite position. This level of precision is provided by the fine orbit position model whose parameters are transmitted to the user as a part of the downlink data. This model is used in conjunction with the updated system time estimates to refine the user position.

2.2.2 Transformation of Satellite Orbit Model Into User Coordinates

The coordinates of the satellite in the earth-centered inertial must be transformed into user coordinates for use in the satellite selection and acquisition process and in the measurement matrix of the Kalman filter. The user coordinate system is a right-hand system with axis directed towards the local zenith, east and north.

The necessary operations to transform the satellite coordinates in the orbital plane system U, V, W into topocentric north-east zenith user coordinates can be written in matrix notation (neglecting flattening) as

$$\begin{bmatrix} N \\ E \\ Z+r_0 \end{bmatrix} = \begin{bmatrix} -\sin \phi \cos \beta & -\sin \phi \sin \beta \cos i & \sin \phi \sin \beta \sin i \\ +\cos \phi \sin i & \cos \beta \cos i & -\cos \beta \sin i \\ -\sin \beta & \cos \phi \sin \beta \cos i & -\cos \phi \sin \beta \sin i \\ \cos \phi \cos \beta & +\sin \phi \sin i & +\sin \phi \cos i \end{bmatrix} \begin{bmatrix} U \\ V \\ W \end{bmatrix}$$

where (U, V, W) are the known coordinates of the satellite,

ϕ = the geocentric latitude

β = true sidereal time (θ) + east longitude of user (λ)
- east longitude of the ascending node (Ω_0)

i = inclination of the orbital plane

r_0 = distance from earth center to user

N, E, Z = coordinates of satellites in north, east, zenith

The elevation angle (γ) and azimuth (σ) to the satellite in topocentric coordinates is obtained from the (N, E, Z) coordinates

$$\text{by } \gamma = \sin^{-1} \left[\frac{Z}{r_s} \right]$$

$$\sigma = \sin^{-1} \left[\frac{E/r_s}{\cos \gamma} \right]$$

where $\frac{Z}{r_s}$, $\frac{E}{r_s}$ and $\frac{N}{r_s}$ are direction cosines to the satellite

and r_s is the distance to the satellite

$$(\ = \sqrt{N^2 + E^2 + Z^2})$$

A.2.3 Constellation Selection

If more than four satellites are visible to the user, then the user must have a procedure for selecting the constellation which produces the best fix. The usual way of accomplishing this is to calculate the Geometric Dilution of Precision (GDOP) by means of the predicted direction cosines to each of the satellites.

Let

$$G_u = \begin{bmatrix} l_1 & m_1 & n_1 & -1 \\ l_2 & m_2 & n_2 & -1 \\ l_3 & m_3 & n_3 & -1 \\ l_4 & m_4 & n_4 & -1 \end{bmatrix}$$

where l_i, m_i are the direction cosines from the user to the "i" th satellite computed for topocentric coordinates.

Then the GDOP matrix corresponding to this particular constellation is

$$\Sigma = \begin{bmatrix} \sigma_{11} & \sigma_{12} & \sigma_{13} & \sigma_{14} \\ \sigma_{21} & \sigma_{22} & \sigma_{23} & \sigma_{24} \\ \sigma_{31} & \sigma_{32} & \sigma_{33} & \sigma_{34} \\ \sigma_{41} & \sigma_{42} & \sigma_{43} & \sigma_{44} \end{bmatrix} = \left[G_u^T G_u \right]^{-1}$$

and $\text{Tr} \left[\Sigma \right] = \{ \sigma_{11} + \sigma_{22} + \sigma_{33} + \sigma_{44} \}^{\frac{1}{2}}$ is the GDOP

Additional measures of position accuracy including circular error probability (CEP) in the user's horizontal plane can be obtained from the diagonal terms; however the quantity of interest here is the GDOP.

Although in principle the user's computer could calculate the GDOP for each possible constellation of four satellites out of the n satellites in view, for conditions where n is as large as 9 or 10,

an exhaustive computation of all possible combinations would be extremely lengthy because of the matrix inversion required.

A much shorter method which promises to achieve nearly equivalent results with much less computation involves computing only the determinant of $|G_u|$ and selecting the constellation which has the largest value. The reason this simpler technique can be expected to yield satisfactory GDOP discrimination is that large GDOP's result when a particular coordinate of the topocentric system is weakly represented in the system made up of the satellite position vectors, which leads to a small eigenvalue along the weakly represented coordinate. Since all of the vectors which make up the rows of G_u are of the same length a small eigenvalue will result in a small value for the determinant, because the determinant of a matrix is equal to the product of its eigenvalues. Although it is fairly obvious that this technique can be used to eliminate extremely poor constellations, it is not clear that it provide adequate discrimination between constellations that both provide a small GDOP. A short program to verify this procedure is being written.

Using one of the above procedures the constellations are ranked in order of geometrical performance; however several other conditions must be met before a particular constellation is selected for navigation. One of these is that none of the satellites in the constellation should be below 5° to 10° in elevation (unless it is the only constellation or all of the other constellations have large GDOP). This condition prevents excessive bias errors caused by ionospheric and tropospheric delays. Another desirable feature of the selected constellation is that none of the satellites should be setting below the low elevation limit before the next constellation update (on the order of fifteen - thirty minutes).

The conditions can be incorporated into the basic GDOP program by multiplying the calculated GDOP by a set of weighting factors

(based on experience) which will cause constellations with low elevation angle satellites to have a low rank (large weighted GDOP). Thus these relatively poor constellations will not be chosen unless the remaining constellations have extremely poor geometry.

Another small point worth consideration is the possibility that the selected constellation could become planar, causing $\begin{bmatrix} G_u^T & G_u \end{bmatrix}$ to be singular, before the next constellation update. This situation can be predicted by examining the GDOP for the next update to see if the determinant will change sign. If it does it will probably be sometime in the interval where the GDOP is very poor. Selection of this constellation should be avoided whenever possible.

A.3 Ionospheric and Tropospheric Correction Techniques

The effect of the ionosphere and troposphere is to increase the absolute delay of propagating signals resulting in a measured range which is greater than the actual range.

Ionospheric delay can be corrected by a two frequency measurement or, with less accuracy, by predictive models of varying degrees of sophistication. Models avoid the additional hardware required by the two frequency correction but require good knowledge of ionospheric parameters for precise range measurements.

With a two frequency measurement, the range correction is

$$\Delta R = \left[p_1 - (f_2/f_1)^2 p_2 \right] / \left[1 - (f_2/f_1)^2 \right]$$

where p_1 and p_2 are the measured ranges at frequencies f_1 and f_2 respectively ($f_1 > f_2$). This formula is only valid at frequencies above 1 GHz. Note that all of the necessary parameters are available directly from receiver measurements.

If two-frequency measurements are not available the ionospheric range correction can still be determined using values predicted by ionospheric models.

One such model [TRW, 1974] gives the range correction R (in feet) as

$$\Delta R = 1.32 \left(1 + \frac{H}{R_e} \right) I_v / f^2 \left(\sin^2 E + \frac{2H}{R_e} + \frac{H^2}{R_e^2} \right)^{1/2}$$

where H = ionospheric scale height

R_e = radius of earth (6378 km)

I_v = vertical electron content (hexams)

E = elevation angle

f = measurement frequency in GHz

Use of this equation requires good knowledge of the ionospheric parameters H and I_V , particularly at low elevation angles. If these parameters are not available to the user it is still possible to make an approximate correction by substituting average values of $H = 350$ km and $I_V = 50$ hexams (the median world-wide daily peak) into the above formula, where E is known from orbital predictions. Under extreme conditions where I_V is quite large or changing rapidly (as in the polar cap region) the accuracy of the correction using this formula using measured ionospheric parameters is probably no better than several meters and is even worse if average values are used.

The two frequency measurement is capable of providing an order of magnitude better accuracy. The primary restriction is that the measurements should be nearly simultaneous so that the ray paths traverse essentially identical ionospheric electron densities.

Unlike the ionospheric delay, tropospheric delay is not correctable by the two frequency technique since the group refractive index is an essentially constant function of frequency for radio frequencies. Thus the delay correction must be made using models. Neglecting the tropospheric delay would cause a 22.4 m range error for a 5.7° elevation angle (0.1 radian) and 11.9 m error for an 11.4° elevation angle (0.2 radians) [Thayer, 1967]. The path length increase due to ray bending can be neglected since it is less than 0.5 m above 5.7° elevation.

An approximate correction formula suitable for small computers which includes both dry and wet terms is [Moffett, 1973]

$$\Delta R_{\text{TROPO}} = K_d P \csc \left[E^2 + \theta_d^2 \right]^{\frac{1}{2}} + K_w \csc \sqrt{E^2 + \theta_w^2}$$

where $K_d = 2.278 \times 10^{-3}$ m/millibar

P = pressure at antenna height (millibars)

E = elevation angle

$\theta_d \approx 2.5^\circ$

$\theta_w \approx 1.5^\circ$

and K_w is a function of latitude, season and weather. Typical values of K_w are 0.28 m in the tropics or midlatitude summer, 0.20 m for midlatitude spring or fall, 0.12 m for midlatitude winter, and 0.05 m in the polar regions. A slightly simpler correction formula which combines wet and dry terms assuming a 50% RH and 288°K temperature is [TRW, 1974]

$$\Delta R_{\text{TROPO}} = 7.8 \csc (E) \exp \left[-h/23000 \right]$$

where h is the user altitude in feet.

In the above expressions the dry term is an order of magnitude larger than the wet term for elevation angles greater than 5°. Thus for low accuracy users there is no requirement for temperature or humidity inputs; however either pressure or at least height is necessary (which can be converted to pressure assuming a standard atmosphere). A 10% error in pressure will result in a 2.5 meter range error for $E = 5^\circ$ and a 1.25 m error for $E = 10^\circ$.

REPORT DOCUMENTATION PAGE		READ INSTRUCTIONS BEFORE COMPLETING FORM
1. REPORT NUMBER SAMSO TR 75-251, Vol III	2. GOVT ACCESSION NO.	3. RECIPIENT'S CATALOG NUMBER
4. TITLE (and Subtitle) NAVSTAR Global Positioning System Special Studies and Engineering Program, Volume III		5. TYPE OF REPORT & PERIOD COVERED Final Report March 1974 - October 1975
		6. PERFORMING ORG. REPORT NUMBER STI TR 10255, Vol III
7. AUTHOR(s) James J. Spilker, Jr. Francis D. Natali Jackson T. Witherspoon		8. CONTRACT OR GRANT NUMBER(s) F04701-74-C-0310
9. PERFORMING ORGANIZATION NAME AND ADDRESS Stanford Telecommunications Inc. 1161 San Antonio Road Mountain View CA 94043		10. PROGRAM ELEMENT, PROJECT, TASK AREA & WORK UNIT NUMBERS NAVSTAR Global Positioning System (GPS)
11. CONTROLLING OFFICE NAME AND ADDRESS HQ SAMSO/YEE PO Box 92960, Worldway Postal Center Los Angeles CA 90009		12. REPORT DATE October 1975
		13. NUMBER OF PAGES 148
14. MONITORING AGENCY NAME & ADDRESS (if different from Controlling Office)		15. SECURITY CLASS. (of this report) Unclassified
		15a. DECLASSIFICATION/DOWNGRADING SCHEDULE N/A
16. DISTRIBUTION STATEMENT (of this Report) DISTRIBUTION STATEMENT B: Distribution limited to U.S. Government agencies only; Test and Evaluation: October 1975. Other requests for this document must be referred to SAMSO(YEE).		
17. DISTRIBUTION STATEMENT (of the abstract entered in Block 20, if different from Report)		
18. SUPPLEMENTARY NOTES		
19. KEY WORDS (Continue on reverse side if necessary and identify by block number) GPS manpack receiver direct acquisition synchronization (GPS) stable oscillators		
20. ABSTRACT (Continue on reverse side if necessary and identify by block number) This volume presents the results of the Manpack Study and Direct Acquisition Study performed under this contract. This report looks at the feasibility of directly acquiring the GPS Precision signal directly without the aid of the Clear signal. This report also addresses the design criteria and specification of a man-portable, or manpack GPS receiver.		