

UNCLASSIFIED

AD NUMBER

ADB009581

LIMITATION CHANGES

TO:

Approved for public release; distribution is unlimited.

FROM:

Distribution authorized to U.S. Gov't. agencies only; Proprietary Information; 28 JAN 1974. Other requests shall be referred to Naval Air Test Facility, Lakehurst, NJ 08733.

AUTHORITY

USNATF ltr, 23 Jul 1976

THIS PAGE IS UNCLASSIFIED

THIS REPORT HAS BEEN DELIMITED
AND CLEARED FOR PUBLIC RELEASE
UNDER DOD DIRECTIVE 5200.20 AND
NO RESTRICTIONS ARE IMPOSED UPON
ITS USE AND DISCLOSURE.

DISTRIBUTION STATEMENT A

APPROVED FOR PUBLIC RELEASE;
DISTRIBUTION UNLIMITED.



Lakehurst, New Jersey

08733

DDC
07
2
REPORT NATF-EN-1135

ADB009581

EVALUATION OF BAK-14 HOOK-CABLE
SUPPORT-SYSTEM MODIFICATIONS

Waldemar Wastallo
Recovery Division, Engineering Department
Naval Air Test Facility
Naval Air Station
Lakehurst, New Jersey 08733

12 FEBRUARY 1976

FINAL REPORT

Test Period: 11 December 1974 - 31 July 1975

Distribution limited to U. S. Government
Agencies only; proprietary information;
28 January 1974. Other requests for this
document must be referred to Commanding
Officer, Naval Air Test Facility, Lake-
hurst, N.J. 08733 ATTN: Code 4000

Prepared for

Commanding Officer
Naval Air Engineering Center
Lakehurst, N.J. 08733

AD No. _____
DDC FILE COPY

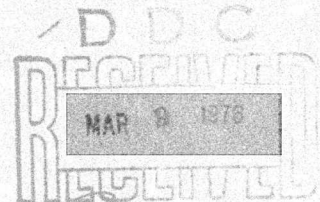

A

NATF-EN-1135

Prepared by: Waldemar Wastallo
Waldemar Wastallo
Recovery Division

Reviewed by: C. T. Abrahamsen
C. T. Abrahamsen
Head, Recovery Division

Approved by: B. F. Kolacz
B. F. Kolacz
Superintendent of Engineering

UNCLASSIFIED

SECURITY CLASSIFICATION OF THIS PAGE (When Data Entered)

REPORT DOCUMENTATION PAGE		READ INSTRUCTIONS BEFORE COMPLETING FORM	
1. REPORT NUMBER NATF-EN-1135 ✓ (9) Final rept. 11 Dec 74 - 31 Jul 75 ✓	2. GOVT ACCESSION NO.	3. RECIPIENT'S CATALOG NUMBER	
4. TITLE (and Subtitle) Evaluation of BAK-14 Hook-Cable Support-System Modifications		5. TYPE OF REPORT & PERIOD COVERED Final, 11 Dec 74/31 Jul 75	
7. AUTHOR(s) Waldemar/Wastallo		6. PERFORMING ORG. REPORT NUMBER	
		8. CONTRACT OR GRANT NUMBER(s)	
9. PERFORMING ORGANIZATION NAME AND ADDRESS Naval Air Test Facility (4210) Naval Air Station Lakehurst, N. J. 08733 ✓	(12) 5430	10. PROGRAM ELEMENT PROJECT TASK AREA & WORK UNIT NUMBERS NAVAIRENGCEN XXXXXXXXXX 78-4-4052 ORDER 4-4052	
11. CONTROLLING OFFICE NAME AND ADDRESS Commanding Officer Naval Air Engineering Center Lakehurst, New Jersey 08733	(11)	12. REPORT DATE 12 Feb 1976 1976	
14. MONITORING AGENCY NAME & ADDRESS (if different from Controlling Office)		13. NUMBER OF PAGES 36	
		15. SECURITY CLASS. (of this report) Unclassified	
		15a. DECLASSIFICATION/DOWNGRADING SCHEDULE	
16. DISTRIBUTION STATEMENT (of this Report) Distribution limited to U.S. Government agencies only; proprietary information; 28 January 1974. Other requests for this document must be referred to Commanding Officer, Naval Air Test Facility, Lakehurst, N.J. 08733			
17. DISTRIBUTION STATEMENT (of the abstract entered in Block 20, if different from Report)			
18. SUPPLEMENTARY NOTES			
19. KEY WORDS (Continue on reverse side if necessary and identify by block number)			
20. ABSTRACT (Continue on reverse side if necessary and identify by block number) The BAK-14 retractable hook-cable support system was designed to raise and restrain the hook cable of the airfield arresting gear above the runway surface for the engagement of hook-equipped aircraft; and to lower and retain the hook cable below the runway surface for those aircraft which require a clear runway. When in battery position, or when lowered, the hook cable is installed in rubber support blocks each of which is mounted on a spring-loaded pneumatically-actuated support arm contained within a metal box on the runway. (Continued on next page) ←			

D D C
RECEIVED
MAR 9 1976
A

UNCLASSIFIED

SECURITY CLASSIFICATION OF THIS PAGE (When Data Entered)

BLOCK 20 (CONTINUED fr p 1473A)

The boxes are located eight feet apart along the trough which accepts the lowered hook cable. The extreme low temperature which exists at the Air Force BAK-14 installation at Galena, Alaska, caused the normally pliable rubber support blocks to become brittle and fracture when the hook cable was extracted by the arrested aircraft; the support-arm latch mechanism within the boxes was also damaged and disabled. The tests of this report were conducted to evaluate a number of modifications designed to permit operation of the BAK-14 at extreme low temperatures. The tests consisted of 100 functional cycles (raise-lower hook cable), 125 aircraft tramples, and 11 aircraft arrestments into the BAK-14 configured with the modifications. The modifications tested were as follows: four changes designed to reduce damage to the standard support block; three restraint reeves designed to secure the hook cable to the support blocks; various changes designed to improve the operation and adjustment of the support-arm latch mechanism; a new-design support-arm latch mechanism; a support-arm bumper spacer; and a reinforced support arm designed to prevent bending of the standard support arm. (Bending was not anticipated but was experienced during these tests.) The optimum support-block and hook-cable-restraint configuration was selected and satisfactorily tested. Operation of the reinforced support arm configured with the modified latch mechanism was satisfactory. The new design support-arm latch mechanism was unsatisfactory due to excessive lost motion in the linkage and also, to installation interference; however, this modification is worthy of additional development. Complete redesign of the support-arm latch mechanism is recommended.



ACCESSION for	
NTIS	White section <input type="checkbox"/>
DDC	Self Section <input checked="" type="checkbox"/>
UNANNOUNCED	<input type="checkbox"/>
JUSTIFICATION.....	
BY.....	
DISTRIBUTION/AVAILABILITY CODES	
Dist.	AVAIL. and/or SPECIAL

UNCLASSIFIED

SECURITY CLASSIFICATION OF THIS PAGE (When Data Entered)

TABLE OF CONTENTS

<u>SECTION</u>	<u>SUBJECT</u>	<u>PAGE</u>
I	INTRODUCTION	3
	A. BACKGROUND.....	3
	B. TEST OBJECTIVES.....	4
	C. PREVIOUS TESTS.....	
II	CONFIGURATION AND DESCRIPTION	4
	A. GENERAL DESCRIPTION.....	6
	B. DETAILED DESCRIPTION.....	
	C. DETAILED DESCRIPTION OF MODIFICATIONS TO HOOK-CABLE SUPPORT BLOCKS.....	11
	D. E-28 ARRESTING SYSTEM.....	15
III	TEST PROGRAM	15
	A. DYNAMIC TESTS.....	16
	B. INSTRUMENTATION.....	16
	C. PHOTOGRAPHIC COVERAGE.....	16
	D. TEST LIMITS.....	16
IV	TEST RESULTS AND DISCUSSION	16
	A. TEST SUMMARY.....	18
	B. AIRCRAFT TRAMPLES.....	18
	C. AIRCRAFT ARRESTMENTS.....	18
	D. FUNCTIONAL CYCLE TESTS.....	19
	E. AIRCRAFT.....	19
	F. SUPPORT BLOCKS.....	19
	G. HOOK-CABLE RESTRAINTS.....	22
	H. INTERIM LATCH MECHANISM.....	23
	I. FINAL LATCH MECHANISM.....	23
	J. DOWN-STOP BUMPER SPACERS.....	23
	K. REINFORCED SUPPORT ARM.....	24
	L. TEST CONFIGURATION SUPPORT ARM.....	24
	M. PUSHER BLOCK.....	24
	N. LATCH SHOULDER SCREW.....	24
	O. SOLENOID-OPERATED VALVE ASSEMBLY.....	25
V	CONCLUSIONS.....	26
VI	RECOMMENDATIONS.....	27
VII	REFERENCES.....	
	APPENDIX A - TEST DATA RECORDED DURING EVALUATION OF BAK-14 HOOK-CABLE SUPPORT-SYSTEM MODIFICATIONS	A-1

LIST OF ILLUSTRATIONS

FIGURE NO.	TITLE	PAGE
1	Sketch of the BAK-14 Hook-Cable Support-System Test Configuration.....	5
2	Standard-Latch-Mechanism Design (Gulf & Western Drawing 52-E-768: Support-Box Assembly, BAK-14).....	*
3	Support-Block Assembly, BAK-14.....	6
4	Forward Translation of Support Block.....	7
5	BAK-14 Test-Configuration Support Arm.....	8
6	Modifications of the Standard Support Block.....	11
7	The Standard Single-Loop-Reeve, the Dual-Loop-Reeve, and the Cross-Loop-Reeve Restraints.....	12
8	Interim-Latch-Mechanism Design (NAEC Drawing 618978: Support-Box Assembly Modification - BAK-14).....	*
9	Support Arm with Final Latch Mechanism Installed.....	13
10	Final-Latch-Mechanism Design (NAEC Drawing MISC 09708: Latch Mechanism Redesigned, Support-Box Assembly - BAK-14).....	*
11	Reinforced Support Arm.....	14
12	Chafed Coated Restraint with the Standard Single-Loop Reeve.....	20
13	Dual-Loop-Reeve Restraint Shifted Out of Position....	20
14	Cross-Loop-Reeve Restraint After Eleven Tramples.....	20
15	Sketch of the Pivot-Assembly Latch and the Modified Pivot-Assembly Latch.....	22

* These drawings are shown following Appendix A at the back of this report.

I INTRODUCTION

A. BACKGROUND

1. The BAK-14 retractable hook-cable support system is designed for use with aircraft arresting systems to facilitate military and civil aircraft operations on Air Force/Civil joint-use airfields. The system is used to raise the hook cable of the arresting restraint system above the runway surface for the arrestment of hook-equipped aircraft and to lower and retain the hook cable below the runway surface to prevent possible interference and damage to aircraft which require a clear runway.

2. In the extreme low-temperature environment of the Air Force BAK-14 installation located at Galena, Alaska, the neoprene-rubber hook-cable support blocks of the BAK-14 are frozen hard and are no longer pliable. As a result, installation of the arresting-system hook cable into the retention hole of the support block requires considerable manual effort. When the hook cable is extracted during aircraft arrestments, the rubber material is fractured and the support-block latch actuating mechanism and the air cylinder are damaged. Thus, the system may be disabled and temporarily out of service as the result of damage caused by a single arrestment.

3. The test program requested and funded by reference (a) was conducted at the NAVAIRTESTFAC (Naval Air Test Facility) at moderate temperature conditions from 11 December 1974 to 31 July 1975. It consisted of A-4, A-3, A-7, A-6, and C-2 aircraft tramples (trample is defined as "to traverse a raised and tensioned hook cable"); and A-4 and A-3 aircraft arrestments into the BAK-14 hook-cable support system which was installed to operate in conjunction with the E-28 arresting system. The results of these tests are presented in this report.

B. TEST OBJECTIVES: The overall objective of this test program was to evaluate the modifications designed by the NAVAIRENGCEN (Naval Air Engineering Center) to permit full operational use of the Air Force BAK-14 arresting system installed in the Galena, Alaska, low-temperature environment. The modifications and changes evaluated were as follows:

1. Four modifications of the standard support blocks: the vertical slot, and the 90°, 120°, and 180° open-top designs.

2. The standard and two nonstandard hook-cable restraint configurations.

3. The interim (modified design) latch mechanism.

Ref: (a) NAVAIRENGCEN Project Order 4-4052 of 29 Apr 1974: BAK-14 Arresting Gear Tests

4. The final (new design) latch mechanism.
5. The support-arm down-stop bumper spacer.
6. The reinforced support arm.

C. PREVIOUS TESTS

1. The test and evaluation of several retractable hook-cable support systems, including the BAK-14 retractable hook-cable support prototype design (Thurston-Erlandsen Corporation hook-cable support assembly) and the early BAK-14 retractable hook-cable support-system designs, are described in references (b) and (c) respectively.

2. Reference (d) describes the extent of the development effort which preceded the reference (e) tests in which the Air Force acceptance requirement for the BAK-14 (76 consecutive successful engagements) was realized.

3. The detrimental effects of extreme low temperature on operations of the BAK-14 are described in reference (f).

II CONFIGURATION AND DESCRIPTION

A. GENERAL DESCRIPTION

1. The primary elements of the BAK-14 hook-cable support system are the rubber blocks which support and restrain the hook cable of the aircraft arresting system approximately 3 inches above the surface of the runway.

2. Each support block is mounted on a support arm contained in a covered metal box inserted in the runway. A steel trough is provided in

- Ref: (b) NAVAIRTESTFAC Report No. NATF-EI-108 of 31 Aug 1964: Evaluation of Retractable Pendant Supports for the Federal Aviation Agency
- (c) Air Force Systems Command, Aeronautical Systems Division, Technical Report No. ASD-TR-69-9 of Aug 1969: BAK-14/F32 Retractable Cable Support System
- (d) Air Force Systems Command, Air Force Flight Test Center, Technical Report No. FTC-TR-72-41 of Mar 1973: Testing of the BAK-14 Retractable Cable Support System
- (e) NAVAIRTESTFAC Report No. NATF-EN-1128 of 22 Jan 1974: Evaluation of the BAK-14 Retractable Hook-Cable Support System
- (f) NAVAIRTESTFAC Report No. NATF-EN-1132 of 27 Aug 1974: BAK-14 Retractable Hook-Cable Support System Cold-Weather Tests at Galena, Alaska

the runway to accept the hook cable. Retraction of the support arm moves the support blocks down into the metal boxes, and the hook cable into the metal boxes and steel trough. Thus, a flush runway surface is obtained when the system is lowered.

3. Retraction of the hook cable is accomplished by means of a pressurized pneumatic system. The hook cable is raised when the system air pressure is vented allowing the spring-loaded support arms to rise. Appropriate switching circuits are provided so that the airfield tower and the BAK-14 operating personnel on the runway may control the position of the hook cable in the up or down position.

4. The BAK-14 hook-cable support system was installed at the existing Navy E-28 arresting-system installation located at the RALS (*Runway Arrested Landing Site*). It consisted of seven support-box assemblies located eight feet apart on the hook-cable trough and offset two feet to the right of the runway centerline as shown in Figure 1. Thus, in the test configuration, the arresting system supported the center 48-foot portion of the hook cable above the surface of the 200-foot-wide runway.

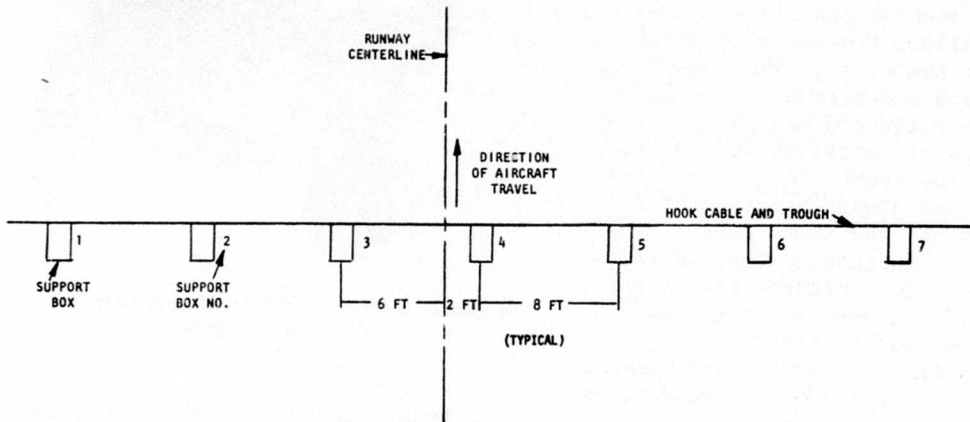

FIGURE I - SKETCH OF THE BAK-14 RETRACTABLE HOOK-CABLE SUPPORT SYSTEM

B. DETAILED DESCRIPTION

1. SUPPORT-BOX ASSEMBLY, G&W (Gulf & Western) PN 52-E-768 (see Figure 2 at the back of this report): This assembly contains the hook-cable support block, the support arm to raise and lower the support block, a torsion spring to raise the arm, a pneumatic cylinder to lower the arm, a watertight electrical compartment, a drain, a heating element to prevent freezing during cold weather, and up and down indicator switches. The cover of the support box, fabricated from one-inch-thick steel plate, is designed to withstand landing-gear loads; limit the full "up" travel of the support arm; and serve as a bearing surface for the support-block cam-plate rollers used to guide the pivot motion of the support block. Bumpers are provided at both travel ends of the support arms to minimize shock from oscillations of the support arm caused by aircraft wheel tramples of the hook cable.

a. SUPPORT-BLOCK ASSEMBLY, G&W PN 52-D-3247 (Figure 3): The hook-cable support-block assembly consists of a neoprene-rubber block that is molded with a metal frame in the base, and provided with a diagonal slot in the top for insertion and removal of the hook cable from the 1-3/8-inch-diameter retention hole in the block body. A shaft, inserted through the frame base of the block and through the support arm, anchors the block to the arm and allows the block to pivot about the shaft. The cam-plate rollers and extension springs which guide and aid in the pivot motion are attached to the base. When the system is lowered, the combined pivoting motion of the block and the arm results in an offset distance of approximately 4-5/8 inches between the raised position of the block (3-inch nominal hook-cable clearance above the runway) and the lowered position of the block (hook cable in the trough) (see Figure 4). The metal frame base of the block is also provided with a through hole to accept the nylon cord required to retain the hook cable in the blocks during cable dynamics caused by aircraft wheel tramples.

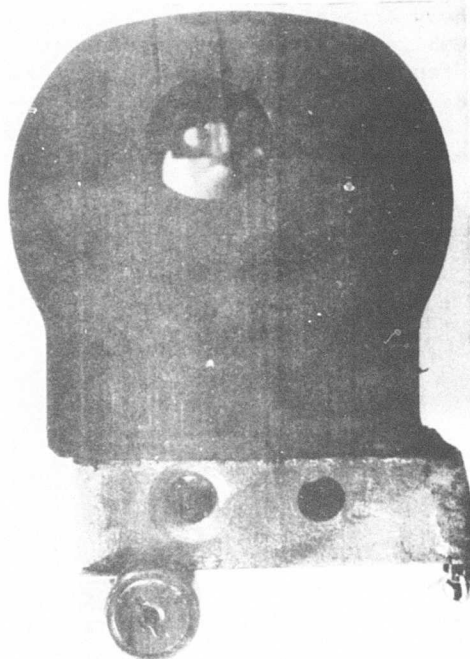

FIGURE 3 - SUPPORT BLOCK ASSEMBLY - BAK-14

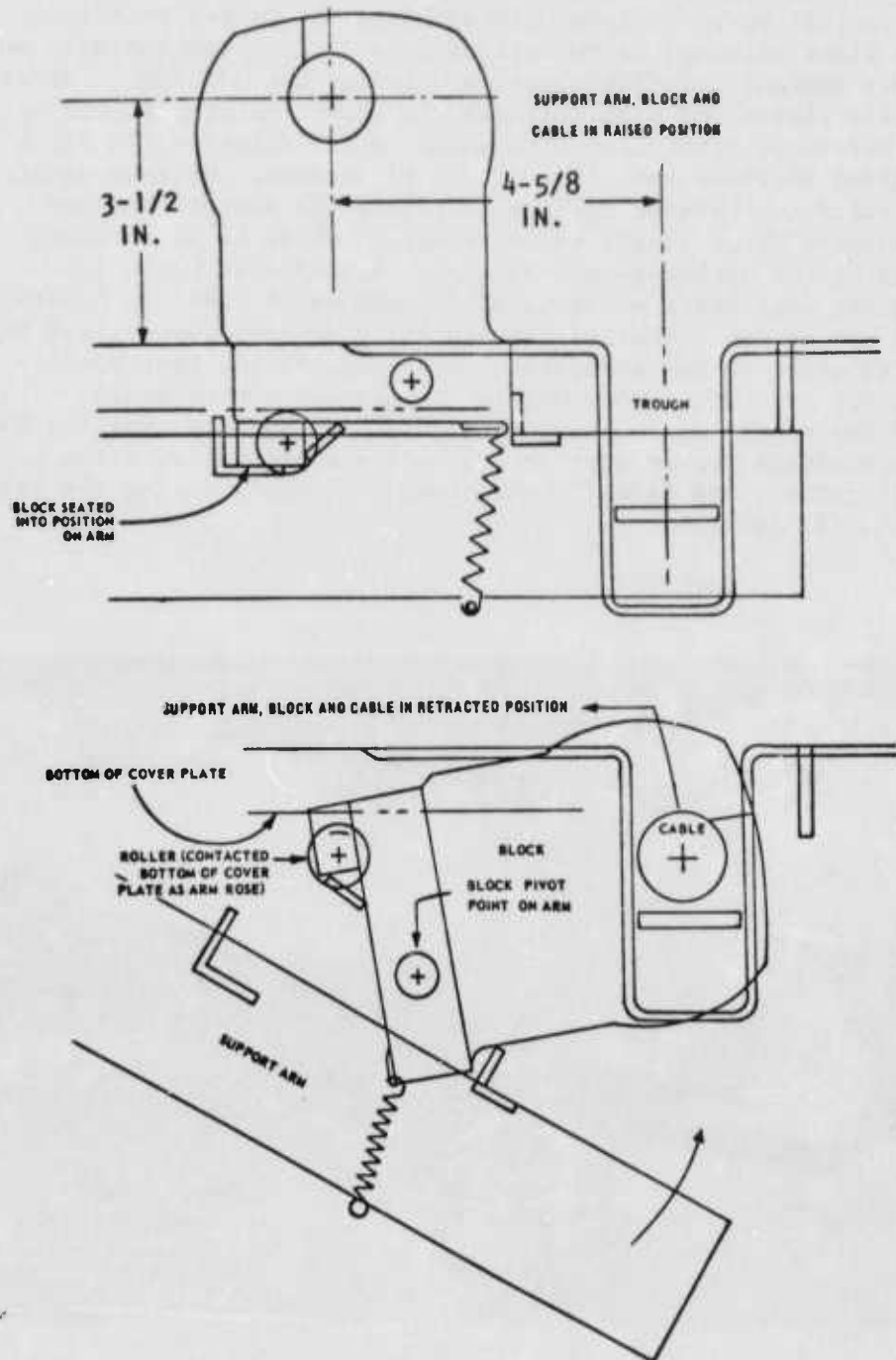

FIGURE 4 - FORWARD TRANSLATION OF SUPPORT BLOCK

NATF-EN-1135

b. SUPPORT ARM, G&W PN 52-E-767 (see Figure 2 at back of this report): The support arm pivots on a shaft and swings in an arc within the support box. To lower the arm from the raised position, the pusher block attached to the air-cylinder piston rod contacts and applies force against the offset yoke and swings the arm down. Simultaneously, the piston rod also actuates the support-block latches by means of a wire-rope pivot-link arrangement which releases the block from the raised position and allows it to pivot down. Release of air pressure permits the torsion springs to rotate the support arm and place the support block in the raised position where it is automatically locked by the spring-loaded latches. Bearings on the support-arm pivot shaft facilitate movement of the arm under load. A 5/8-inch-thick steel spacer was installed beneath the down-stop bumper, G&W PN 52-B-6189, to decrease and standardize the distance the test configuration support arms swing down within the support-box assembly. The addition of the spacer was a convenient method of compensating for the lack of the standard tip or striker pad on the test-configuration support arms (Figures 5 and 2) which were used previously during the tests of references (d) and (e).

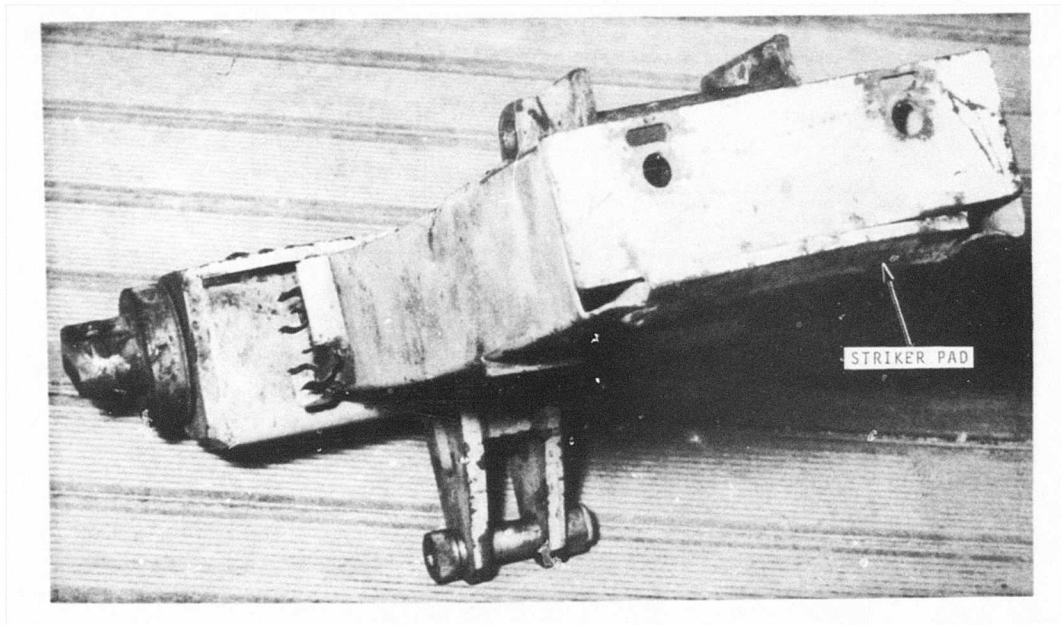

FIGURE 5 - BAK-14 TEST-CONFIGURATION SUPPORT ARM

c. Also contained within the support box is an electrical junction box, sealed with watertight gaskets, which serves the up/down indicating switches and such electrical elements and thermostats required for heater operation.

d. A heated drain is provided in the bottom of the support box to avoid the accumulation of water. A screen prevents undesirable items from entering the drainage system. The support-box drain opening is connected to the cross-runway drain which discharges into the runway-drainage-ditch system.

2. HOOK-CABLE TROUGH, G&W PN 52-D-2616: The steel trough provides a protective recess in the runway surface for retraction of the hook cable. It also provides a space for routing the compressed-air supply line and heater elements beneath the trough cover on which the retracted hook cable rests. The trough is located 90° to the runway centerline and is aligned with the tape-payout side of the arresting-system deck sheaves. Individual trough sections are installed between the support boxes and in a 24-foot series arrangement to each runway edge called the end trough.

3. PNEUMATIC SYSTEM

a. High-pressure air bottles (3,000 psig), located in a control shed on one side of the runway, supply the system with air through a pressure regulator at 120 psig maximum working pressure. When electrically actuated, the three-way solenoid valve allows the 120-psig air to enter the 5/8-inch supply line, located in the bottom of the trough, and then into the actuating cylinders in the support boxes. These cylinders apply a force to the support arms which in turn lower the hook cable into the trough. The hook cable will remain down as long as the air cylinders are sufficiently pressurized.

b. The hook cable is raised when the 3-way solenoid valve is de-energized or if the electric power fails. In either case, the 3-way solenoid valve shuts off the air supply and, in conjunction with the quick-exhaust valve located in the near-side hand hole at the runway edge, vents the compressed air to the atmosphere. In the event of the loss of either air pressure or electrical power, the torsion springs automatically raise the supports and hook cable; thus the system is fail-safe in the up position.

c. Manual operation of the system is possible by means of the manual override feature of the 3-way solenoid valve. In the event of an electrical power failure, this feature may be used to operate the system.

4. ELECTRICAL CONTROL SYSTEM: The BAK-14 controls operate on 115-volt alternating current, single phase, 60 Hertz power supply. The master control is located in the airfield tower and the portable control, at the control shed on one side of the runway. Either control may be used to operate the system. The control cables are shielded to prevent malfunctions which can be caused by stray current and interference fields. All control-panel lights have the push-to-test feature.

a. Only the tower master control is provided with a selector switch by which the tower or the runway portable control may be activated for control of the system. The master control also has a red light to indicate that the portable control is activated; a switch to raise and lower the hook cable; and lights to indicate that the hook cable is up or down.

b. The portable control is installed on the end of a shielded extension cable which is grounded through the disconnect fitting in the control shed. This feature allows the BAK-14 operator to control (with tower permission) and observe the system operation at the runway edge or to remove the portable control from the system with no effect on tower control. The portable control has a green light to indicate its activation by the tower; a switch to raise and lower the hook cable; and lights to indicate that the hook cable is up or down.

c. The raise and retract functions of both controls are monitored by mercury-type limit switches, installed on each support arm to indicate whether the arm is up or down. The switches are in series with the system UP/DOWN position-indicator light circuit, so failure in any one support box will prevent the hook-cable position light on the control from lighting. Such failure can be either mechanical or electrical, or can be a switch malfunction. To avoid checking a multitude of possibilities on the runway, a continuity check circuit is provided in the control shed and permits locating the faulty switch/support box. Thus, only one support box need be opened to correct the problem.

5. HEATER SYSTEM: A support-box heater was provided in this installation. It is a mineral-insulated, stainless-steel sheathed-type unit with potted leads attached to a cold section. The heater is located near the bottom of the box, surrounds the pneumatic cylinder, provides direct contact with the air line, and is capable of wet/dry service. The unit is easily accessible once the support arm has been rotated up out of the way, and it can be taken out without removing the pneumatic cylinder or breaking the air line.

C. DETAILED DESCRIPTION OF MODIFICATIONS TO HOOK-CABLE SUPPORT BLOCKS

1. MODIFIED SUPPORT BLOCKS: The modified support blocks (Figure 6) were designed to decrease block damage when the supported hook cable is extracted during aircraft arrestments at extremely low temperatures, and to hold the restrained hook cable in the support blocks when the system is cycled (raised and lowered). The modifications consisted of the removal of the neoprene rubber from the top of the block with the aid of a band saw to reduce block grip on the hook cable. Support blocks were fabricated incorporating four modifications in which the hook-cable openings on the blocks were progressively increased from a vertical slot to a wide-open flat top.

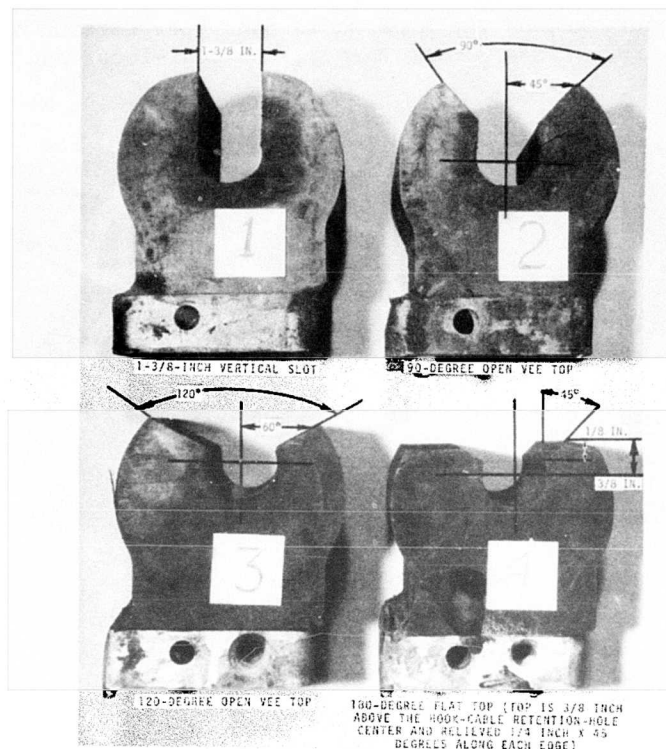

FIGURE 6 - MODIFICATIONS OF THE STANDARD SUPPORT BLOCK

The most desirable modification would be the support block with the widest-angle open top that retains the hook cable during aircraft tramples and functional-cycle operation of the system when the hook cable is secured with the nylon cord restraint.

2. HOOK-CABLE RESTRAINTS (Figure 7): The nylon cords used to restrain the hook cable in the standard support block are reported to elongate and loosen when they become wet and are worn by chafing action of the support block, the hook cable, and the support-box cover. Because retention of the hook cable in the modified open-top support block is totally dependent on the effectiveness of the restraint, the development of an improved configuration was undertaken. The material used to fabricate the restraints was 7-foot lengths of nylon parachute cord (breaking strength - 500 pounds) 1/8-inch in diameter; either uncoated, or coated with one or two coats of GACO abrasive-resistant paint. The coating was applied by dipping and submerging the cord in the paint maintained at room temperature. All restraints were configured with the doubled nylon cord reeved through the anchor hole provided in the base of the support block and then around the hook cable where it was tied with a square knot. The three methods of reeving the doubled cord around the hook cable and upper portion of the support block were: the standard single-loop, the dual-loop, and the cross-loop reeves.

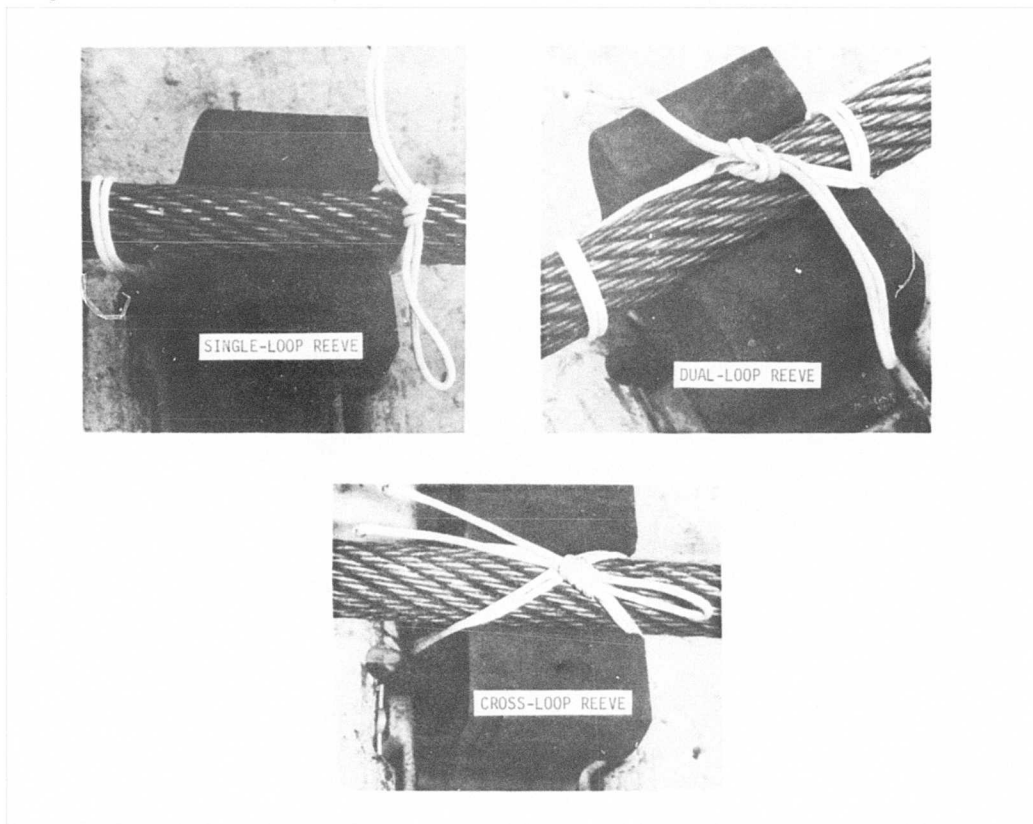

FIGURE 7 - THE STANDARD SINGLE-LOOP-REEVE, THE DUAL-LOOP-REEVE, AND THE CROSS-LOOP-REEVE RESTRAINTS

3. INTERIM LATCH MECHANISM (see Figure 8 at the back of this report): The interim latch mechanism was designed to provide a timely and effective remedy as soon as possible for the various discrepancies encountered with the standard latch mechanism during reference (f). The interim latch-mechanism design consists of the basic standard latch mechanism modified to provide additional features as follows:

- a. Latch springs with tamper-proof closed anchor loops.
- b. Latch-spring anchor clips which are easily handled without tools.
- c. Pivot shaft brackets securely anchored with through bolts.
- d. Improved access for latch adjustment.

4. FINAL LATCH MECHANISM (Figure 9): As the name implies, the final latch-mechanism design was intended as the ultimate long-term remedy for the problems experienced with the standard latch mechanism during reference (f) testing. The design was based on a new method of latch actuation in which the wire rope, pivot assembly, and spoke arrangement of the standard mechanism were replaced by a forked-shaped rod and drive-pin arrangement. This design was not dynamically tested or adopted for use. The drawing of the final latch mechanism is presented in Figure 10 at the back of this report.

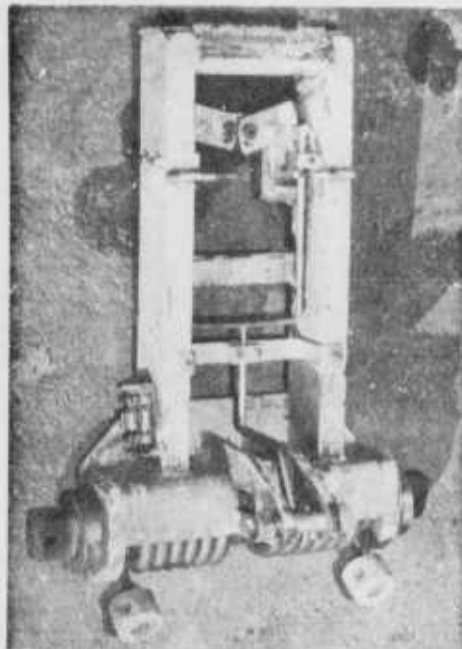

FIGURE 9 - SUPPORT ARM WITH FINAL LATCH MECHANISM INSTALLED

5. DOWN-STOP BUMPER SPACER: A 5/8-inch-thick spacer was placed beneath the down-stop bumper (G&W PN 52-8-6189) to compensate for the lack of the standard striker pad in the test-configuration support-arm design. Additional spacers were installed in 1/2-inch increments up to a total thickness of 2-1/8 inches to prevent interference damage between the pivot assembly and air cylinder caused by bending of the support arm. Spacer elements were fabricated from 1/8-inch-thick mild steel plate according to the dimensions of the down-stop bumper.

6. REINFORCED SUPPORT ARM (Figure 11): The reinforced support arm was designed to prevent bending of the rectangular tubing of the test-configuration support arm (identical to the standard support-arm tubing) by aircraft and trample loads. The reinforcement consisted of 3/16-inch-thick mild steel plate welded to the top and bottom surfaces of the rectangular tubing of the support arm.

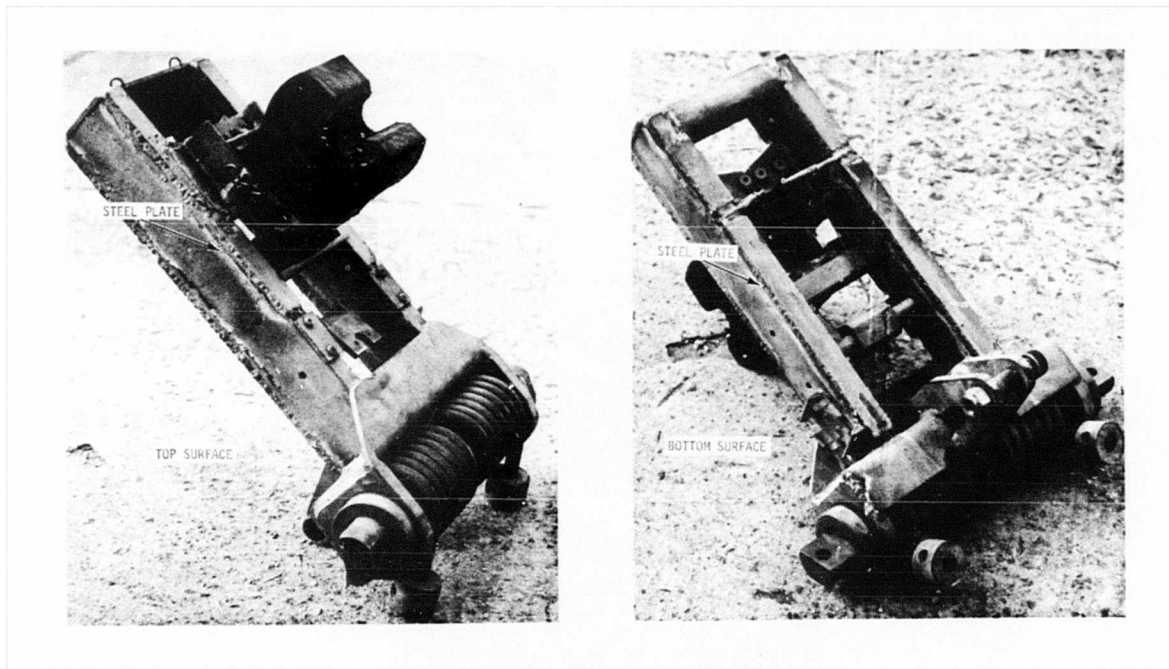

FIGURE 11 - REINFORCED SUPPORT ARM

D. E-28 ARRESTING SYSTEM: The BAK-14 retractable hook-cable support system was used in conjunction with the E-28 arresting system located at Station 60 + 53 of the 12,000-foot-long by 200-foot-wide runway. The arresting system was configured as follows:

1. Arresting-sheave span - 225 feet.
2. Purchase element - uncoated nylon, NAEC PN 510534-8-920SP, 920 feet long X 8 inches wide X 0.35 inch thick.
3. Hook cable - nonrotating wire rope, NAEC PN 515053-190-0, 190 feet long X 1-1/4 inches diameter.
4. Pressure roller - spring actuated, NAEC PN 08807.
5. Absorber fluid - 60% ethylene glycol (rust inhibited)/40% water solution.

E. AIRCRAFT: During these tests, the BAK-14 was subjected to tramples and arrestments of operational aircraft as follows:

<u>Type</u>	<u>Test Aircraft</u>	
	<u>Maximum Short-Field Landing Weight (Lb) (Reference (g))</u>	<u>Main Wheel Span (Ft)</u>
A-3	50,000	10.4
A-4	14,500	7.8
A-6	36,000	11.0
A-7	25,300	9.5
C-2	46,000	19.5

Aircraft actual gross weights and store configurations were presumed not to have a significant bearing on results of these tests and, therefore, were not recorded. Aircraft tire pressures were maintained as specified for shipboard operation.

III TEST PROGRAM

A. DYNAMIC TESTS: The hook cable of the E-28 arresting gear was installed on the seven support blocks of the BAK-14 test configuration; secured to each support block with a nylon-cord restraint; and subjected to aircraft tramples, arrestments, and functional cycles (raise-lower supported hook cable) which are described on the following page.

Ref: (g) Aircraft Recovery Bulletin No. 46-12F of 18 Mar 1974 for E-28 Arresting Gear (Span 225 to 425 feet)

1. Aircraft tramples and arrestments were conducted at the nominal ON-CENTER engaging position on runway heading 300° into the BAK-14 with support-box assemblies located on the upstream side of the hook-cable trough. Landing roll-in and touch-and-go roll-in approach methods were used for the tramples. The taxi roll-in approach method was used for the arrestments.

2. The BAK-14 was configured initially with support-block modification No. 1 and subjected to a series of aircraft tramples followed by 25 consecutive functional cycles of the system. Because of inspection and repair requirements, which required removal of the hook cable from the support blocks after trample tests, all the cycle tests were completed under ideal conditions with newly tied and tight hook-cable restraints. This procedure was repeated in sequence with support-block modifications 2, 3, and 4.

3. After completion of the trample and cycle tests, the optimum configuration, namely, support block modification No. 4, was selected and tested with 11 arrestments.

4. The support-box assemblies were externally inspected after each aircraft test and internally inspected after each series of aircraft tests.

B. INSTRUMENTATION: Aircraft trample and engaging speeds were measured by means of wire coils imbedded in the runway surface.

C. PHOTOGRAPHIC COVERAGE: A 16-mm high-speed motion picture camera with a fixed-ground base and a film speed of 500 frames per second was used to monitor the BAK-14 support blocks, the restraints, and the hook cable. The camera was located behind the E-28 arresting sheave on the south side of the runway approximately in line with the battery position of the hook cable. A Speed Graphic camera was used to take still photographs of equipment and equipment failures.

D. TEST LIMITS: The trample and engaging-speed limit of 125 knots was deliberately exceeded during 11 tramples to determine the effect of high speeds (127 to 154 knots) on the reinforced support arms.

IV TEST RESULTS AND DISCUSSION

A. TEST SUMMARY

1. During this test program, a total of 125 aircraft tramples and 11 aircraft arrestments was conducted into the BAK-14 retractable hook-cable support system. The data for each test event are tabulated in Appendix A. The aircraft utilized for the tests are listed on the following page.

Type	Aircraft	Number of Events	
	Speed Range (Kn)	Tramples	Arrestments
A-3	42 - 112	34	1
A-4	61 - 154	52	10
A-6	63 - 120	13	0
A-7	62 - 96	25	0
C-2	83	1	0

2. The BAK-14 supported hook cable was functionally cycled 25 times with each of four support-block modifications.

3. The various BAK-14 modifications were subjected to aircraft tramples and arrestments as follows:

BAK-14 Modification	Figure No.	Number of Events	
		Tramples	Arrestments
Support block No. 1	6	64	0
Support block No. 2	6	13	0
Support block No. 3	6	12	0
Support block No. 4	6	30	11
Standard support block	3	6	0
Standard single-loop-reeve restraint	7	18	0
Dual-loop-reeve restraint	7	30	0
Cross-loop-reeve restraint	7	77	11
Interim latch mechanism	8	125	11
Final latch mechanism	9	0	0
Down-stop bumper spacer (0 inch)	-	59	0
" " " (5/8 inch)	-	35	11
" " " (1-1/8 inches)	-	12	0
" " " (1-5/8 inches)	-	9	0
" " " (2-1/8 inches)	-	10	0
Reinforced support arm	10	12	10

B. AIRCRAFT TRAMPLES: The major portion of the testing consisted of 125 nominal ON-CENTER aircraft tramples at engaging speeds of 42 to 154 knots into the BAK-14 system configured with modified open-top support blocks tied to the hook cable with nylon-cord restraints.

1. Hook-cable dynamics produced by aircraft tramples were not significantly influenced by the modified open-top support blocks and the nylon parachute-cord restraints even though the hook cable was not restrained as tightly as with the standard closed-top support-block configuration. The inherent elasticity of the nylon-cord restraint allowed the hook cable to lift within the supports and transmit a portion of the cable upward motion to the adjacent cable-support span. The characteristic feature of the standard BAK-14 hook-cable support system is the ability of the support blocks to almost totally reflect and thereby isolate cable oscillations between each support span.

2. The most frequently damaged components of the BAK-14 system were contained in runway support boxes 2, 3, 4, and 5 (see Figure 1) which are located near the runway centerline. The support blocks at these locations sustained the highest number of aircraft tire impacts and near impacts which severely damaged the support mechanisms within the boxes. Damage to support mechanisms within boxes 1, 6, and 7 by comparison was negligible.

C. AIRCRAFT ARRESTMENTS: These tests consisted of 10 ON-CENTER arrestments of the A-4 aircraft at engaging speeds of 104 to 134 knots and one ON-CENTER arrestment of the A-3 aircraft at an engaging speed of 51 knots into the BAK-14 system configured with support-block modification No. 4 tied to the hook cable with the cross-loop-reeve nylon-cord restraints.

1. All attempts to engage the hook cable were successful; no bolters occurred. High-speed motion-picture coverage indicates that each restraint is stretched and remains intact up to and shortly after extraction of the hook cable from the support block.

2. The motion-picture coverage also indicates that support-block modification No. 4 was deflected forward by extraction of the hook cable. The maximum deflection angle of the supports was at least forty-five degrees. The maximum-possible deflection angle of ninety degrees was reached with the standard closed-top support block as indicated by motion-picture coverage and support impact marks on the deck.

D. FUNCTIONAL CYCLE TESTS: The BAK-14 supported hook cable was cycled satisfactorily 25 times in succession with each set of modified support blocks. The hook cable was secured to the support block with the newly-tied cross-loop reeve restraints before each of the four cycle tests.

1. Restraints were slightly loosened and square knots were tightened by the hook-cable cycling.

2. No indication of restraint wear or damage was found.

E. AIRCRAFT: Aircraft sustained no damage during the testing.

F. SUPPORT BLOCKS: The four support-block modifications and the standard support block were subjected to 136 aircraft tramples and arrestments and 100 functional cycles (see paragraph IVA3) when installed in the BAK-14 hook-cable support system.

1. When tied with the cross-loop-reeve restraints, the hook cable was retained in the modified and the standard support blocks after completion of every aircraft trample and the functional cycle operation of the system. As stated in paragraph IIIA3, support-block modification No. 4 was selected as the optimum configuration.

2. Aircraft tramples of the hook cable, which was installed in modified open support blocks with dual-loop-reeve restraints, produced cable-dynamic characteristics similar to those obtained with plastic-rail or tire-section supports when the restraints were stretched or loosened.

3. The most effective restraint of the hook cable was provided by the standard closed-top support block tied with the cross-loop-reeve restraint.

4. During the testing, three support blocks were sheared off at the base; two, by hook impacts of non-project aircraft when the hook cable was not installed on the BAK-14 support blocks and one, by extraction of the hook cable from a previously-weakened support by the arrested A-4 aircraft. No damage was sustained in the hook-cable retention area of the support blocks.

G. HOOK-CABLE RESTRAINTS: The three hook-cable-restraint reeve methods tested were as follows: The standard single loop - 18 tramples; the dual loop - 30 tramples; and the cross loop - 77 tramples and 11 arrestments. Each reeve method was evaluated and the optimum method was selected in conjunction with the testing of support-block modification No. 1. The optimum was found to be the cross-loop reeve. Support block modifications No. 2, 3, and 4 and the standard support block were then tested with the cross-loop-reeve configuration. Uncoated and GACO-coated nylon-cord restraints were also evaluated.

1. STANDARD SINGLE-LOOP-REEVE RESTRAINT (Figure 12): The axial movement of the hook cable caused by the aircraft trample shifted the looped cord away from the side of the support block. The extended loop was then exposed to chafing contact against the support-box cover when the support arm was depressed by the aircraft trample. Seven single-loop-reeve restraints failed or were damaged in this manner during the 18 aircraft tramples.

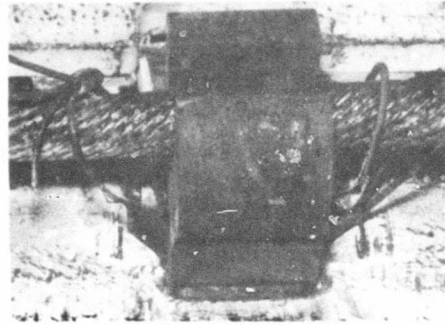

FIGURE 12 - CHAFED COATED RESTRAINT WITH THE STANDARD SINGLE-LOOP REEVE

2. DUAL-LOOP-REEVE RESTRAINT (Figure 13): Two failures occurred during completion of 30 aircraft tramples with the dual-loop-reeve restraint; namely, a failure of the restraint cord, and a failure to retain the hook cable in the modified open-top support block although the restraint was still intact. Both failures may have been caused by the decreased strength and the increased elasticity of the dual-loop reeve which divides the hook-cable restraint load among four cords compared to eight cords in the standard single-loop reeve and the cross-loop reeve.

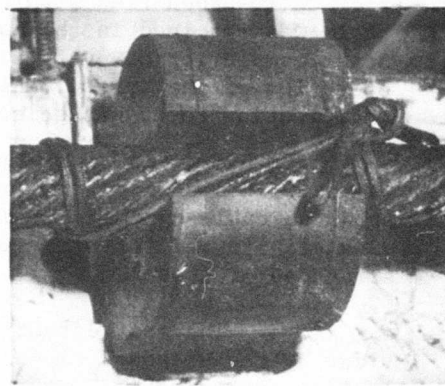

FIGURE 13 - DUAL-LOOP-REEVE RESTRAINT SHIFTED OUT OF POSITION

3. CROSS-LOOP-REEVE RESTRAINT (Figure 14): The cross-loop-reeve restraint was not shifted out of position by the axial movement of the hook cable as was the standard single-loop-reeve restraint. It, therefore, was not subject to chafing by the support-box cover. By comparison, only minor chafing damage was experienced during the completion of 77 aircraft tramples with this restraint configuration. High-speed motion-picture coverage indicates that the most effective restraint and retention of the hook cable was provided by the cross-loop reeve.

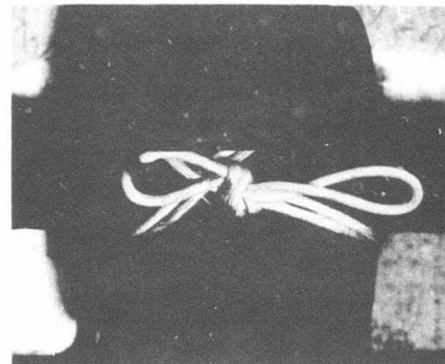

FIGURE 14 - CROSS-LOOP-REEVE RESTRAINT AFTER ELEVEN TRAMPLES

4. GACO-COATED RESTRAINTS: Analysis of the limited quantity of restraint-failure data available indicates that the standard single-loop reeve and the dual-loop reeve resulted in the largest number of restraint discrepancies regardless of whether or not GACO coating was applied to the restraint. The superiority of the cross-loop-reeve and the GACO-coated restraints is indicated by the minimum number and nature of the discrepancies obtained with this combination. The restraint failure data is summarized in the table below.

No. of Tramples	Restraint Configuration		Number and Type of Failures			
	Type Reeve	No. of Coats of GACO	Restraint			Cable Out of Block**
			Loose	Chafed	Broken	
7	Standard	0	0	1	2	1
11	Standard	2	1	2	2	1
14	Dual-loop	0	2	2	0	0
16	Dual-loop	2	1	0	1	1
47	Cross-loop	0	0	4*	0	0
12	Cross-loop	1	0	0	0	0
18	Cross-loop	2	0	0	0	0

* 1 recorded, 3 additional estimated.

** Restraint intact.

The coated restraints appeared less elastic and retained the square knot more securely than uncoated restraints. The coating stiffened the nylon parachute cord so that it could be installed in the hole provided in the base of the support block without the aid of a wire hook.

During fabrication of the coated restraints by the dip-coating method, the outer sleeve of the nylon parachute cord was saturated and there was partial penetration of the GACO abrasive-resistant paint to the inner strands. When the procedure was repeated after the first coat was dry, the second dipping resulted in a thick surface coat which further decreased the flexibility of the restraint.

The nylon-cord restraints, when covered and saturated with a single coat of GACO paint, possess adequate stiffness for ease of installation and provide protection against the detrimental effects of chafing, elongation due to moisture, and deterioration caused by sunlight.

H. INTERIM LATCH MECHANISM (see Figure 8): Interim latch mechanisms were installed in runway support boxes 4 and 5 (see Figure 1) for the 136 aircraft tests and the 100 cycle functional tests of the BAK-14 system. No problems were encountered with the latch springs, latch-spring anchor clips, pivot-shaft bracket anchors, or with the operation of the improved-access latch adjustment. Interference and installation problems were encountered with the pivot assembly, NAEC PN 517049, and the modified pivot assembly (Figure 15) as follows:

1. The bottom portion of each pivot assembly interfered with the head retaining screw located near the top of the air cylinder when the support arm was depressed during aircraft tramples.
 - a. The heavy-to-light interference of the pivot assembly resulted in extensive damage to the air-cylinder pivot-assembly shaft, pivot-assembly shaft brackets, and latch spokes primarily because of support-arm bending experienced during project events 1 through 114.
 - b. Light contact interference occurred with the modified pivot assembly, reinforced (straight) support arm, and 5/8-inch down-stop bumper-spacer configuration (see paragraph IIC5) during events 115 through 126.
 - c. The interference was eliminated during events 127 through 136 after installation of an additional 1/2-inch spacer (total spacer 1-1/8 inches). However, complete retraction of the support blocks was now prevented; approximately 1/2 inch of each block protruded above the surface of the runway when the system was lowered.
2. Installation of the pivot-assembly nut-plate retaining nuts, PN MS 21044-6, was extremely difficult because of the poor accessibility of the nut plate and the very small size of the nuts.

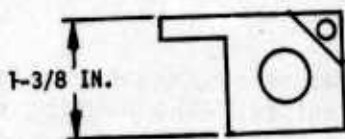

PIVOT-ASSEMBLY LATCH (NAEC PN 517049)

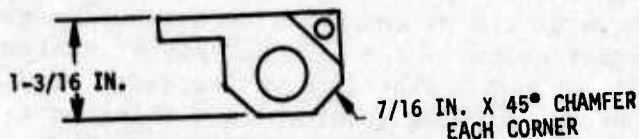

MODIFIED PIVOT-ASSEMBLY LATCH

FIGURE 15 - SKETCH OF THE PIVOT-ASSEMBLY LATCH AND THE MODIFIED PIVOT-ASSEMBLY LATCH

I. FINAL LATCH MECHANISM (see Figure 9): The final latch mechanism was initially assembled for a functional checkout in the shop on a reinforced support arm. It was found that maximum axial movement of the forked rod did not sufficiently actuate the latches due to excessive lost motion of the latch-drive pins. Installation of the assembled latch-mechanism support-arm into runway support box No. 3 was prevented by interference of the end of the forked rod with the pusher block on the air-cylinder piston rod. For these reasons, the final latch mechanism was not tested in the BAK-14 system.

J. DOWN-STOP BUMPER SPACERS: During inspection and repair of damage caused by pivot-assembly interference with the air cylinder after event 59 (Appendix A), it was discovered that 1) the test configuration support arms did not have the standard striker pad (see paragraph IIC5) and 2) the rectangular tubing of the support arms located in runway support boxes 2, 3, 4, and 5 (Figure 1) was slightly bent. Because considerable additional testing was planned, it was decided to compensate for the lack of the standard striker pad by the addition of a 5/8-inch spacer beneath the down-stop bumper, and to add more spacers if the interference damage caused by support-arm bending continued. Support-arm bending and interference damage continued when testing was resumed despite installation of down-stop bumper spacers of 5/8, 1-1/8, and 2-1/8 inch(es) during events 60 through 114. High-speed motion-picture coverage failed to show any difference between the downswing travel of the support arms configured with standard closed-top or modified open-top support blocks. After event 114, the remainder of the testing was completed with reinforced support arms installed in runway support box locations 2, 3, 4, and 5 with 5/8- or 1-1/8-inch down-stop bumper spacers.

K. REINFORCED SUPPORT ARM (see Figure 11): The reinforced support arms were deliberately exposed to a series of 12 high-speed tramples with the A-4 aircraft at speeds of 88 to 154 knots and 10 arrestments of the A-4 aircraft at engaging speeds of 96 to 134 knots. Inspection of the reinforced support arms after completion of the aircraft tests disclosed no bending or impact damage.

L. TEST CONFIGURATION SUPPORT ARM (see Figure 5): The test configuration support arms were exposed to a total of 136 aircraft tests in runway support-box locations 1, 6, and 7, and to 114 aircraft tests in locations 2, 3, 4, and 5. Support-arm bending caused by high inertial loads developed in the torsion spring-loaded support arm from impact of the aircraft tire was the most serious problem encountered during the tests. The principal effect of the bending was to disable the latch-actuating mechanism and air cylinder by causing interference between the pivot assembly and air cylinder. The permanent bend damage is probably the result of metal fatigue which was first detected after event 59. The physically identical group of support arms used in these tests was previously exposed to approximately 302 aircraft tests (references (d) and (e)).

NATF-EN-1135

M. PUSHER BLOCK, G&W PN 52-B-6198: The pusher block, located on the end of the air cylinder piston rod in support boxes 4 and 5, was twisted out of rotational alignment with the support-arm offset yoke after events 126 and 104 respectively. In both cases, the latch-actuating mechanism was disabled when the latch cable assembly and the cable anchor failed.

N. LATCH SHOULDER SCREW, G&W PN 52-E-768-34: The shoulder screws which fasten and guide the movement of the latches on the end of the support arm were bent in support boxes 2, 3, 4, and 5 after event 59; the screws were straightened but bent again in succeeding events. This caused the latches to function erratically and to jam. Each screw was bent in the thread-shoulder transition area. When new shoulder screws were procured and installed, no further problems were experienced.

O. SOLENOID-OPERATED VALVE ASSEMBLY, G&W PN 52-D-2649: The solenoid-operated valve which is normally used to charge and vent the pneumatic system was not used during this test. Air leakage and erratic operation were not eliminated even after the recommended repair was made in the gage shop. The valve functioned satisfactorily during the tests of reference (e) and was used only occasionally thereafter. In order to conduct the tests of this report, the solenoid valve was removed and a manually-actuated dual-valve arrangement was installed.

V CONCLUSIONS

- A. Normal BAK-14 cable dynamics caused by aircraft trample were not significantly altered even though the restrained hook cable has greater freedom in the modified open-top support block. (Paragraph IVB1)
- B. Aircraft trample damage to support mechanisms was confined almost totally to support boxes at or adjacent to the impact position of the aircraft tire. (Paragraph IVB2)
- C. Aircraft were not damaged during the tests. (Paragraph IVE)
- D. The deflection of the optimum open-top support block (modification No. 4) was less than that of the standard support block during arrestment extraction of the hook cable but was greater than expected and may be indicative of support-block base-separation damage at extremely low temperatures. (Paragraph IVC2)
- E. The hook cable was satisfactorily restrained and retained in support block modification No. 4 when tied with the cross-loop-reeve restraint. (Paragraph IVD, IVF1)
- F. The best restraint configuration was provided by the cross-loop reeved nylon parachute cord covered and saturated with one coat of GACO abrasive-resistant paint. (Paragraph IVG4)
- G. The operation of the interim latch mechanism was satisfactory when the system was configured with the reinforced test-configuration support arm, and the 1-1/8-inch spacer (equivalent to 1/2-inch spacer with standard support arm) beneath the down-stop bumper. However, when the system is retracted, a 1/2-inch portion of the support block remains above the runway surface. (Paragraph IVH1c)
- H. The attachment design of the interim latch-mechanism pivot-assembly nut plate is unsatisfactory because of the poor accessibility of the nut plate and the small size of the nut, PN MS-21044-6. (Paragraph IVH2)
- I. The operation and condition of the reinforced support-arm were satisfactory after 22 aircraft tests. (Paragraph IVK)
- J. The alignment of the pusher block with the support arm offset yoke was not maintained during the tests. (Paragraph IVM)
- K. The design of the latch shoulder screw installation is unsatisfactory. (Paragraph IVN)
- L. The solenoid-operated valve assembly was unsatisfactory. (Paragraph IVO)

M. The forked rod design of the final latch mechanism has potential as a simplified method of latch actuation. However, the design is unsatisfactory in its present state. (Paragraph IVI)

VI RECOMMENDATIONS

A. Install reinforced support arms in all runway support boxes to insure maximum service life and interchangeability.

B. Install and evaluate support-block modification No. 4 under extremely low temperature conditions.

C. Secure the hook cable to the support block with the cross-loop-reeve nylon-parachute-cord restraint covered and saturated with one coat of Gaco abrasive-resistant paint.

D. Install the interim latch mechanism, reinforced support arm, and 1/2-inch down-stop-bumper spacer. If required, trim 1/2 inch off the exposed side of the lowered support block to obtain a flush runway surface. Fabricate a special wrench to hold the nut, PN MS-21044-6, during installation of the pivot-assembly nut plate.

E. Design a positive guide to maintain the rotational alignment of the pusher block with the support-arm offset yoke.

F. Redesign the latch shoulder screw installation so that only the shoulder portion of the screw is loaded in shear.

G. Provide additional information concerning the operation, maintenance, and repair of the solenoid-operated valve assembly.

H. Redesign the support arm and latch-actuating mechanism based on the results and experience of these tests.

VII REFERENCES

- (a) NAVAIRENGCEN Project Order 4-4052 of 29 April 1974: BAK-14 Arresting-Gear Tests
- (b) NAVAIRTESTFAC Report No. NATF-EI-108 of 31 Aug 1964: Evaluation of Retractable Pendant Supports for the Federal Aviation Agency
- (c) Air Force Systems Command, Aeronautical Systems Division, Technical Report No. ASD-TR-69-9 of Aug 1969: BAK-14/F32 Retractable Cable Support System
- (d) Air Force Systems Command, Air Force Flight Test Center, Technical Report No. FTC-TR-72-41 of Mar 1973: Testing of the BAK-14 Retractable Cable Support System
- (e) NAVAIRTESTFAC Report No. NATF-EN-1128 of 22 Jan 1974: Evaluation of the BAK-14 Retractable Hook-Cable Support System
- (f) NAVAIRTESTFAC Report No. NATF-EN-1132 of 27 Aug 1974: BAK-14 Retractable Hook-Cable Support System Cold-Weather Tests at Galena, Alaska
- (g) Aircraft Recovery Bulletin No. 46-12F of 18 Mar 1974 for E-28 Arresting Gear (Span 225 to 425 feet)

APPENDIX A - TEST DATA RECORDED DURING EVALUATION OF BAK-14 HOOK-CABLE SUPPORT-SYSTEM MODIFICATIONS

Project Event No.	Date	Aircraft Speed (Kn)		Type Event	Type Support/Modification No.	Restraint		Spacer Size (In.)	Remarks
		Type	Speed			Type Reeve	No. of GACO Coats		
1	11 Dec 74	A-3	111	Trample	1	Standard	2	None Installed	Interim latch mechanism installed in support boxes 4 and 5 for all events.
2	"	"	111	"	"	"	"	"	
3	"	"	105	"	"	"	"	"	
4	"	A-7	80	"	"	"	"	"	Support box No. 4 restraint failed; cable was found alongside support.
5	"	A-3	71	"	"	"	"	"	
6	"	A-7	85	"	"	"	"	"	Support box No. 4 restraint replaced.
7	"	"	82	"	"	"	"	"	Support box No. 3 restraint chafed; Support box No. 4 restraint loose.
8	"	A-4	91	"	"	"	"	"	
9	"	A-7	80	"	"	"	"	"	Support box No. 3 restraint replaced.
10	"	"	85	"	"	"	"	"	Support box No. 3 restraint chafed; replaced.
11	"	"	78	"	"	"	"	"	Support box No. 3 restraint failed.
12	12 Dec 74	"	85	"	"	"	0	"	
13	"	"	91	"	"	"	"	"	Restraints in satisfactory condition; loosened.
14	"	"	96	"	"	"	"	"	

Project Event No.	Date	Aircraft Speed (Kn)		Type Event	Type Support/Modification No.	Restraint		Spacer Size (In.)	Remarks
		Type	Speed			Type Reeve	No. of GACO Coats		
15	12 Dec 74	A-7	83	Trample	1	Standard	0	None Installed	Support box No. 3 - restraint damaged; Support box No. 4 - restraint failed.
16	"	A-4	96	"	"	"	"	"	
17	"	A-7	81	"	"	"	"	"	
18	"	"	90	"	"	"	"	"	Support box No. 3 restraint failed; cable was found alongside support.
19	"	"	74	"	"	Dual Loop	"	"	
20	"	A-3	66	"	"	"	"	"	Support box No. 4 - block loose at base.
21	13 Dec 74	A-4	83	"	"	"	"	"	Support box No. 5 - spokes failed prior to trample.
22	"	"	88	"	"	"	"	"	Support boxes No. 3 and 4 - restraints loosened.
23	"	"	88	"	"	"	"	"	Restraint loose; able to lift cable out of No. 3 support block.
24	"	C-2	83	"	"	"	"	"	
25	"	A-4	83	"	"	"	"	"	
26	"	"	100	"	"	"	"	"	
27	"	"	80	"	"	"	"	"	
28	"	"	77	"	"	"	"	"	
29	"	"	94	"	"	"	"	"	
30	"	"	93	"	"	"	"	"	

Project Event No.	Date		Aircraft Speed (Kts)		Type Event	Type Support/Modification No.	Restraint		Spacer Size (In.)	Remarks
			Type				Type Reeve	No. of GACO Coats		
31	13 Dec 74	A-4	99		Trample	1	Dual Loop	0	None Installed	
32	"	"	61		"	"	"	"	"	Support box No. 3 - restraint chafed; others in good condition.
33	"	"	103		"	"	"	2	"	
34	"	"	100		"	"	"	"	"	
35	17 Dec 74	"	72		"	"	"	"	"	
36	"	"	77		"	"	"	"	"	
37	"	"	89		"	"	"	"	"	
38	18 Dec 74	A-7	68		"	"	"	"	"	
39	"	"	71		"	"	"	"	"	Support box No. 3 - restraint loose.
40	"	A-4	100		"	"	"	"	"	
41	"	"	77		"	"	"	"	"	
42	"	A-7	63		"	"	"	"	"	Support box No. 3 - latch-cross member damaged. Repaired after event No. 59.
43	"	"	63		"	"	"	"	"	
44	"	"	78		"	"	"	"	"	
45	"	"	62		"	"	"	"	"	
46	"	"	77		"	"	"	"	"	Cable found alongside No. 3 support block; restraints in satisfactory condition; cable reinstalled.

Project Event No.	Date	Aircraft Speed (Kn)		Type Event	Type Support/Modification No.	Restraint		Spacer Size (In.)	Remarks
		Type	Speed (Kn)			Type Reeve	No. of GACO Coats		
47	18 Dec 74	A-7	95	Trample	1	Dual Loop	2	None Installed	Support box No. 4 - restraints failed.
48	"	"	82	"	"	"	"	"	Support Box No. 4 - restraints replaced.
49	"	"	77	"	"	Cross Loop	0	"	Support box No. 4 - restraints loose.
50	"	A-4	84	"	"	"	"	"	
51	"	A-7	75	"	"	"	"	"	
52	"	A-4	86	"	"	"	"	"	
53	"	A-3	90	"	"	"	"	"	
54	"	A-4	71	"	"	"	"	"	
55	"	"	80	"	"	"	"	"	
56	"	A-3	42	"	"	"	"	"	
57	"	A-4	81	"	"	"	"	"	
58	"	"	*	"	"	"	"	"	
59	"	A-7	*	"	"	"	"	"	

Restraints in satisfactory condition.
 Support box No. 3 - latch weldment cracked; air cylinder inoperative.
 Support Boxes 3, 4, and 5 - pivot shaft and brackets bent; air cylinder damaged.
 Support boxes 2, 3, 4, and 5 - support arms bent; latch shoulder screws bent.
 Support boxes 4 and 5 - spokes broken.
 Damage was repaired.
 Final latch mechanism: Excessive lost motion in latch drive pins; end of rod interfered with pusher block; assembly in box 1 to 2 hours.
 Cycled hook cable 25 times with Mod 1 supports.

* Not Recorded.

Project Event No.	Date	Aircraft		Type Event	Type Support/ Modification No.	Restraint		Spacer Size (In.)	Remarks
		Type	Speed (kn)			Type Reeve	No. of GACO Coats		
60	14 Jan 75	A-4	79	Trampoline	1	Cross Loop	0	5/8	
61	"	"	71	"	"	"	"	"	
62	15 Jan 75	"	71	"	"	"	"	"	
63	"	"	72	"	"	"	"	"	
64	"	"	100	"	"	"	"	"	Support box No. 4 - would not unlatch.
65	17 Jan 75	"	70	"	2	"	"	"	
66	"	A-3	89	"	"	"	"	"	
67	"	"	88	"	"	"	"	"	
68	"	"	93	"	"	"	"	"	
69	"	"	96	"	"	"	"	"	Support box No. 4 - latch spring was loose (see event 77).
70	"	"	95	"	"	"	"	"	
71	"	"	95	"	"	"	"	"	
72	"	"	91	"	"	"	"	"	
73	"	"	112	"	"	"	"	"	
74	"	"	88	"	"	"	"	"	
75	"	"	87	"	"	"	"	"	
76	"	"	87	"	"	"	"	"	

Project Event No.	Date	Aircraft		Type Event	Type Support/Modification No.	Restraint		Spacer Size (In.)	Remarks
		Type	Speed (Kn)			Type Reeve	No. of GACO Coats		
77	17 Jan 75	A-3	55	Trample	2	Cross Loop	0	5/8	Restraints in good condition. Support Box No. 4 - spokes broken; pivot shaft and brackets bent; air cylinder dented. Damage was repaired. A-4 hook hit and dislodged support; hook cable was not installed. Hook cable was cycled 25 times with Mod. 2 supports.
78	24 Jan 75	A-6	103	"	3	"	"	1-1/8	
79	"	"	101	"	"	"	"	"	
80	"	"	103	"	"	"	"	"	
81	"	"	100	"	"	"	"	"	
82	"	"	96	"	"	"	"	"	
83	"	"	93	"	"	"	"	"	
84	"	"	63	"	"	"	"	"	Support box No. 5 - spokes were unscrewed; support block springs were loose; pivot shaft was bent; air cylinder was dented.
85	"	A-3	94	"	"	"	"	"	
86	"	"	105	"	"	"	"	"	
87	"	"	101	"	"	"	"	"	
88	"	"	100	"	"	"	"	"	
89	"	"	73	"	"	"	"	"	Damage from event 84 was repaired. Hook cable was cycled 25 times with Mod. 3 supports.
9C	29 Jan 75	A-6	120	"	Standard	"	"	5/8	

Project Event No.	Date		Aircraft Speed (kn)		Type Event	Type Support/Modification No.	Restraint		Spacer Size (In.)	Remarks
	Type	Type	Type	No. of GACO Coats			Type Reeve	No. of GACO Coats		
91	29 Jan 75	A-6	80	80	Trample	Standard	Cross Loop	0	5/8	
92	"	"	115		"	"	"	"	"	
93	"	"	105		"	"	"	"	"	
94	"	"	82		"	"	"	"	"	Support box No. 3 - cross bar and pivot assembly impacted air cylinder (standard latch). Interim latch in satisfactory condition; one restraint damaged. Damage was repaired.
95	"	A-3	105		"	"	"	"	"	Support box No. 4 - spoke broken.
96	3 Feb 75	A-4	120		"	4	"	2	1-5/8	Support box No. 5 - Arm partially down.
97	"	"	110		"	"	"	"	"	
98	"	"	112		"	"	"	"	"	
99	"	"	103		"	"	"	"	"	
100	"	"	113		"	"	"	"	"	
101	"	"	107		"	"	"	"	"	
102	"	"	90		"	"	"	"	"	
103	"	"	91		"	"	"	"	"	
104	"	A-6	103		"	"	"	"	"	Support boxes No. 2, 3, 4, and 5 - pivot assemblies contacted air-cylinder screw head; pusher block cable anchor on No. 5 support box twisted out of alignment; damage was repaired; hook cable was cycled 25 times with Mod. 4 supports.

Project Event No.	Date	Aircraft Speed (Kn)		Type Event	Type Support/Modification No.	Restraint		Spacer Size (In.)	Remarks
		Type	Speed			Type Reeve	No. of GACO Coats		
105	14 Feb 75	A-3	99	Trample	4	Cross Loop	2	2-1/8	
106	"	"	83	"	"	"	"	"	
107	"	"	88	"	"	"	"	"	
108	"	"	84	"	"	"	"	"	
109	"	"	94	"	"	"	"	"	
110	"	"	87	"	"	"	"	"	
111	"	"	81	"	"	"	"	"	
112	"	"	82	"	"	"	"	"	
113	"	"	77	"	"	"	"	"	
114	"	"	51	Arrestment	"	"	"	"	
115	9 Jul 75	A-4	127	Trample	"	"	1	5/8	
116	"	"	139	"	"	"	"	"	
117	"	"	147	"	"	"	"	"	
118	"	"	141	"	"	"	"	"	

Support box No. 4 - pivot assembly (interim latch) contacted air-cylinder screw head; box No. 3 - latch weldment cracked and arm bent approximately 1/2 inch. Damage was repaired.

Reinforced support arms were installed at support boxes 2, 3, 4, and 5; modified pivot assemblies were installed at boxes 4 and 5 for the remainder of the tests.

Project Event No.	Date	Aircraft Speed		Type Event	Type Support/ Modification No.	Restraint		Spacer Size (In.)	Remarks
		Type	(Kn)			Type Reeve	No. of GACO Coats		
119	9 Jul 75	A-4	143	Trample	4	Cross Loop	1	5/8	
120	"	"	143	"	"	"	"	"	
121	"	"	149	"	"	"	"	"	
122	"	"	154	"	"	"	"	"	
123	"	"	152	"	"	"	"	"	
124	"	"	144	"	"	"	"	"	
125	"	"	146	"	"	"	"	"	
126	"	"	88	"	"	"	"	"	
127	16 Jul 75	"	104	Arrest- ment	"	"	0	1-1/8	Support box No. 3 - latch cable was loose. Support box No. 4 - pivot assembly contacted air cylinder, and pusher block was twisted out of position. Damage was repaired.
128	"	"	125	"	"	"	"	"	
129	"	"	127	"	"	"	"	"	
130	"	"	127	"	"	"	"	"	
131	23 Jul 75	"	134	"	"	"	"	"	Support box No. 4 - block pulled from base and pusher block twisted out of position.
132	31 Jul 75	"	96	"	"	"	"	"	
133	"	"	118	"	"	"	"	"	
134	31 Jul 75	A-4	115	Arrest- ment	4	Cross Loop	0	1-1/8	
135	"	"	125	"	"	"	"	"	
136	"	"	125	"	"	"	"	"	Reinforced support arms showed no evidence of bending upon final inspection; no pivot- assembly or air-cylinder contact.

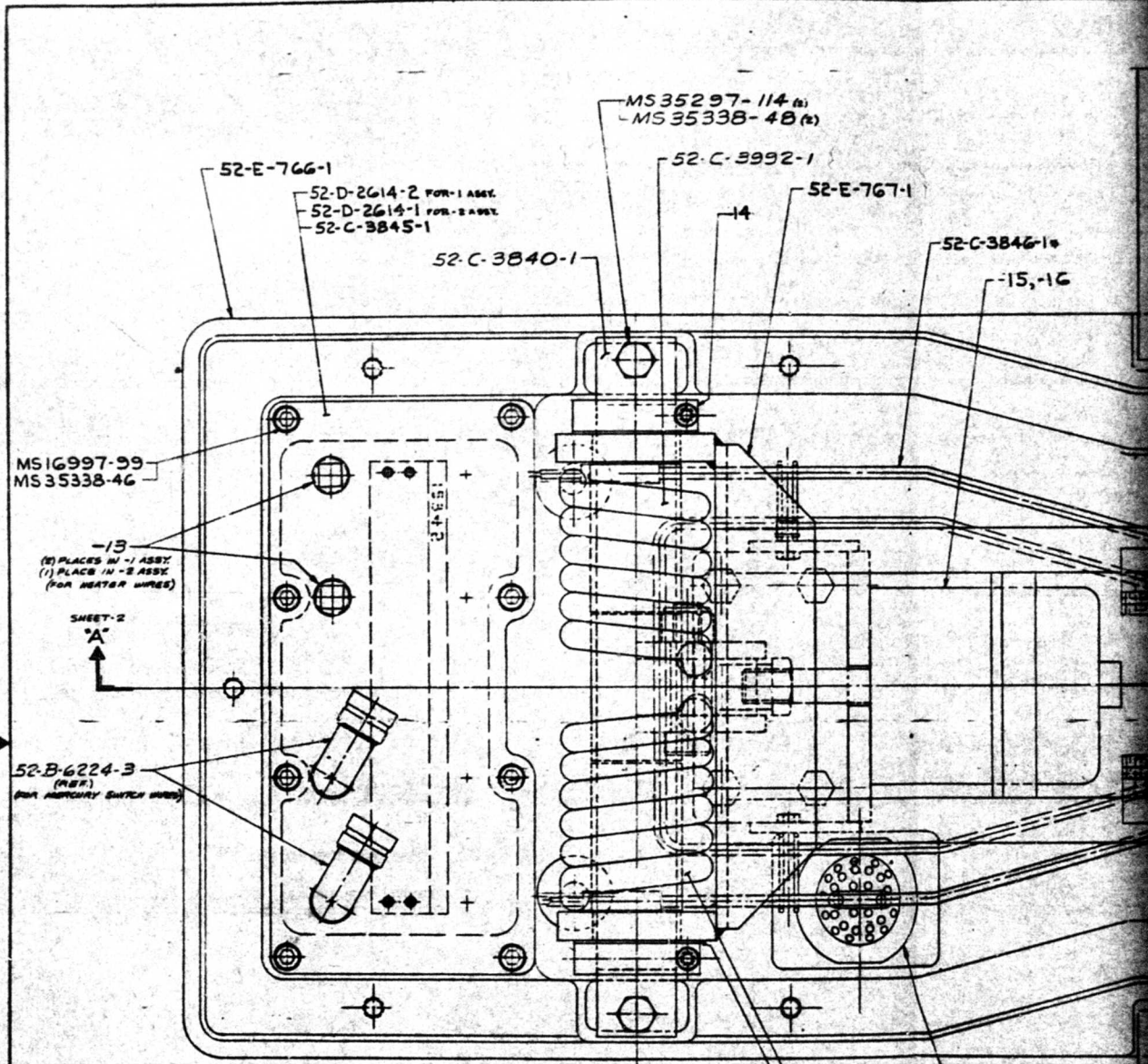

PLAN VIEW
(COVER PLATE & LATCH MECHANISM NOT SHOWN)

N	ADD'D	NOV-7	REV	BY	CHK'D
G	150-3845-1	1	1	PR	150
F	150-3845-1	1	1	PR	150
E	150-3845-1	1	1	PR	150
D	150-3845-1	1	1	PR	150
C	150-3845-1	1	1	PR	150
B	150-3845-1	1	1	PR	150
A	150-3845-1	1	1	PR	150

ITEM NO.	DESCRIPTION	QTY	UNIT	REMARKS
1	52-B-6165-1	1	PC	
2	52-C-3992-2	1	PC	
3	52-E-767-1	1	PC	
4	52-C-3846-1	1	PC	
5	52-C-3840-1	1	PC	
6	52-D-2614-1	1	PC	
7	52-D-2614-2	1	PC	
8	52-E-766-1	1	PC	
9	MS35338-4B	1	PC	
10	MS35297-114	1	PC	
11	MS16997-99	1	PC	
12	52-B-6224-3	1	PC	
13	13	1	PC	
14	14	1	PC	
15	15	1	PC	
16	16	1	PC	

ITEM NO.	DESCRIPTION	QTY	UNIT	REMARKS
17	52-C-3845-1	1	PC	
18	52-C-3845-1	1	PC	
19	52-C-3845-1	1	PC	
20	52-C-3845-1	1	PC	
21	52-C-3845-1	1	PC	
22	52-C-3845-1	1	PC	
23	52-C-3845-1	1	PC	
24	52-C-3845-1	1	PC	
25	52-C-3845-1	1	PC	
26	52-C-3845-1	1	PC	
27	52-C-3845-1	1	PC	
28	52-C-3845-1	1	PC	
29	52-C-3845-1	1	PC	
30	52-C-3845-1	1	PC	

52-B

- NOTE
1. BRUSH ALL SURF. COAT
 2. MATERIAL IS SUBJECT TO VARIATION MANUFACTURING ALLOWANCE
 3. FROM FIG
 4. ITEMS MARKED WITH @ ARE SUPPLIED BY HEATER & INSTALLATION KIT 52-B-6346-1
 5. COAT ALL UN-FINISHED METAL SURFACES WITH BOLT & SCREW THREADS IN SIDE OF BUSHING WITH BUSHING-SEES COMPOUND FROM "LIGHT" BOX ASSY 52-B-765-1 INCLUDES
 6. (BND BOX WITH COVER, 52-D-2610-1 SPRING BLOCK 52-B-6170-2, 175.000. 01.01. 52-C-3846-1 SET - (REV. MS 35297-113)
 7. INSTALLATIONS FOR PRESSING BUSHING INTO SUPPORT ARM:
 - a. REMOVE ANY BURRS & FOREIGN MATTER FROM HOLE IN ARM
 - b. PLACE BUSHING SQUARELY OVER HOLE IN ARM
 - c. APPLY PRESSURE BETWEEN PARALLEL SURFACES SUCH AS OBTAINABLE WITH AN ANVIL OR PRESS OR ADJUSTABLE PRESSURE PNEUMATIC OR OIL HYDRAULIC SQUEEZER
 - d. DO NOT HAMMER AS BEARING CAN BE DISTORTED
 - e. PRESS FLUSH TO OUTSIDE SURFACE.

7-1

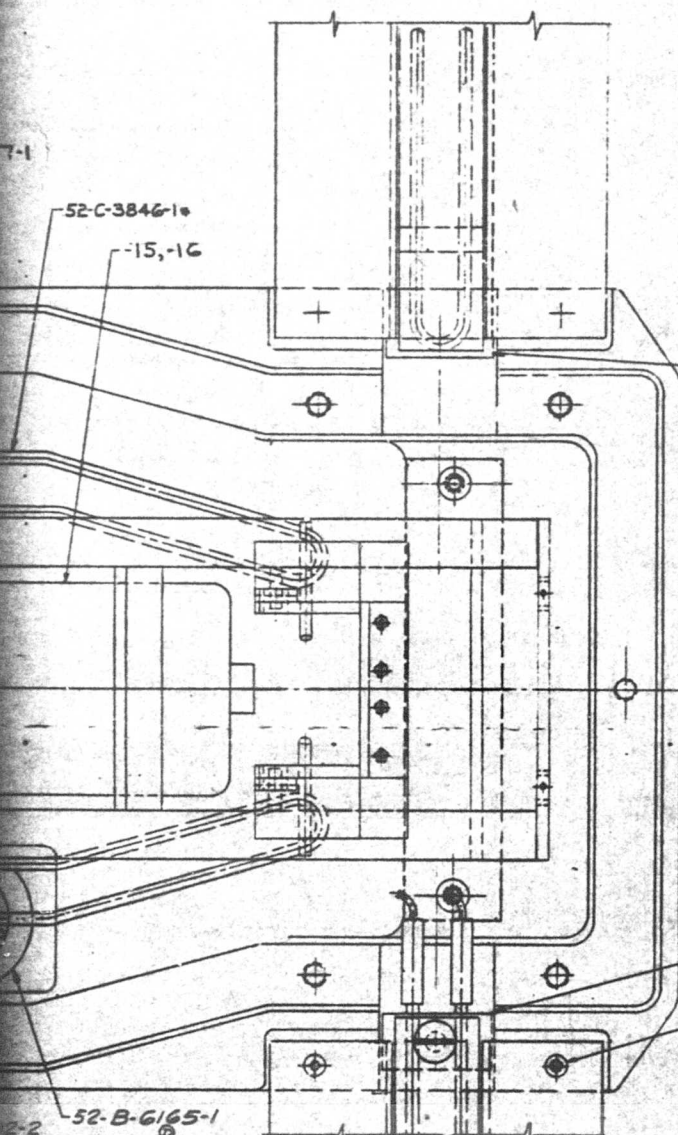

SHEET-2
"A"

M55

M5352
M5353

MS 35297-113 (M)
MS 35338-48 (M)

52-D-2610-1 REF.
52-B-6346-1
SEE NOTE-5

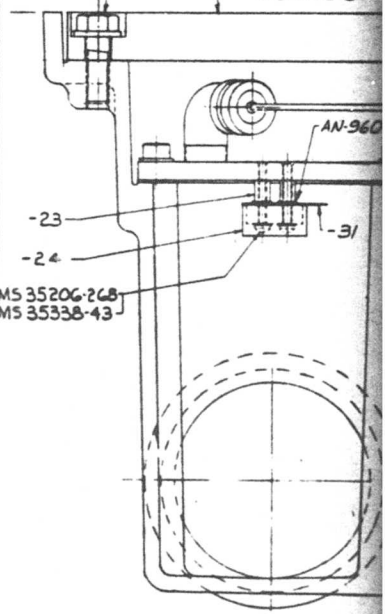

QTY	DESCRIPTION	REF	UNIT
1	52-B-6165-1		
1	52-C-3846-1		
1	52-D-2610-1		
1	52-E-761-1		
1	52-F-761-1		
1	52-G-761-1		
1	52-H-761-1		
1	52-I-761-1		
1	52-J-761-1		
1	52-K-761-1		
1	52-L-761-1		
1	52-M-761-1		
1	52-N-761-1		
1	52-O-761-1		
1	52-P-761-1		
1	52-Q-761-1		
1	52-R-761-1		
1	52-S-761-1		
1	52-T-761-1		
1	52-U-761-1		
1	52-V-761-1		
1	52-W-761-1		
1	52-X-761-1		
1	52-Y-761-1		
1	52-Z-761-1		
1	52-AA-761-1		
1	52-AB-761-1		
1	52-AC-761-1		
1	52-AD-761-1		
1	52-AE-761-1		
1	52-AF-761-1		
1	52-AG-761-1		
1	52-AH-761-1		
1	52-AI-761-1		
1	52-AJ-761-1		
1	52-AK-761-1		
1	52-AL-761-1		
1	52-AM-761-1		
1	52-AN-761-1		
1	52-AO-761-1		
1	52-AP-761-1		
1	52-AQ-761-1		
1	52-AR-761-1		
1	52-AS-761-1		
1	52-AT-761-1		
1	52-AU-761-1		
1	52-AV-761-1		
1	52-AW-761-1		
1	52-AX-761-1		
1	52-AY-761-1		
1	52-AZ-761-1		
1	52-BA-761-1		
1	52-BB-761-1		
1	52-BC-761-1		
1	52-BD-761-1		
1	52-BE-761-1		
1	52-BF-761-1		
1	52-BG-761-1		
1	52-BH-761-1		
1	52-BI-761-1		
1	52-BJ-761-1		
1	52-BK-761-1		
1	52-BL-761-1		
1	52-BM-761-1		
1	52-BN-761-1		
1	52-BO-761-1		
1	52-BP-761-1		
1	52-BQ-761-1		
1	52-BR-761-1		
1	52-BS-761-1		
1	52-BT-761-1		
1	52-BU-761-1		
1	52-BV-761-1		
1	52-BW-761-1		
1	52-BX-761-1		
1	52-BY-761-1		
1	52-BZ-761-1		
1	52-CA-761-1		
1	52-CB-761-1		
1	52-CC-761-1		
1	52-CD-761-1		
1	52-CE-761-1		
1	52-CF-761-1		
1	52-CG-761-1		
1	52-CH-761-1		
1	52-CI-761-1		
1	52-CJ-761-1		
1	52-CK-761-1		
1	52-CL-761-1		
1	52-CM-761-1		
1	52-CN-761-1		
1	52-CO-761-1		
1	52-CP-761-1		
1	52-CQ-761-1		
1	52-CR-761-1		
1	52-CS-761-1		
1	52-CT-761-1		
1	52-CU-761-1		
1	52-CV-761-1		
1	52-CW-761-1		
1	52-CX-761-1		
1	52-CY-761-1		
1	52-CZ-761-1		
1	52-DA-761-1		
1	52-DB-761-1		
1	52-DC-761-1		
1	52-DD-761-1		
1	52-DE-761-1		
1	52-DF-761-1		
1	52-DG-761-1		
1	52-DH-761-1		
1	52-DI-761-1		
1	52-DJ-761-1		
1	52-DK-761-1		
1	52-DL-761-1		
1	52-DM-761-1		
1	52-DN-761-1		
1	52-DO-761-1		
1	52-DP-761-1		
1	52-DQ-761-1		
1	52-DR-761-1		
1	52-DS-761-1		
1	52-DT-761-1		
1	52-DU-761-1		
1	52-DV-761-1		
1	52-DW-761-1		
1	52-DX-761-1		
1	52-DY-761-1		
1	52-DZ-761-1		
1	52-EA-761-1		
1	52-EB-761-1		
1	52-EC-761-1		
1	52-ED-761-1		
1	52-EE-761-1		
1	52-EF-761-1		
1	52-EG-761-1		
1	52-EH-761-1		
1	52-EI-761-1		
1	52-EJ-761-1		
1	52-EK-761-1		
1	52-EL-761-1		
1	52-EM-761-1		
1	52-EN-761-1		
1	52-EO-761-1		
1	52-EP-761-1		
1	52-EQ-761-1		
1	52-ER-761-1		
1	52-ES-761-1		
1	52-ET-761-1		
1	52-EU-761-1		
1	52-EV-761-1		
1	52-EW-761-1		
1	52-EX-761-1		
1	52-EY-761-1		
1	52-EZ-761-1		
1	52-FA-761-1		
1	52-FB-761-1		
1	52-FC-761-1		
1	52-FD-761-1		
1	52-FE-761-1		
1	52-FG-761-1		
1	52-FH-761-1		
1	52-FI-761-1		
1	52-FJ-761-1		
1	52-FK-761-1		
1	52-FL-761-1		
1	52-FM-761-1		
1	52-FN-761-1		
1	52-FO-761-1		
1	52-FP-761-1		
1	52-FQ-761-1		
1	52-FR-761-1		
1	52-FS-761-1		
1	52-FT-761-1		
1	52-FU-761-1		
1	52-FV-761-1		
1	52-FW-761-1		
1	52-FX-761-1		
1	52-FY-761-1		
1	52-FZ-761-1		
1	52-GA-761-1		
1	52-GB-761-1		
1	52-GC-761-1		
1	52-GD-761-1		
1	52-GE-761-1		
1	52-GF-761-1		
1	52-GG-761-1		
1	52-GH-761-1		
1	52-GI-761-1		
1	52-GJ-761-1		
1	52-GK-761-1		
1	52-GL-761-1		
1	52-GM-761-1		
1	52-GN-761-1		
1	52-GO-761-1		
1	52-GP-761-1		
1	52-GQ-761-1		
1	52-GR-761-1		
1	52-GS-761-1		
1	52-GT-761-1		
1	52-GU-761-1		
1	52-GV-761-1		
1	52-GW-761-1		
1	52-GX-761-1		
1	52-GY-761-1		
1	52-GZ-761-1		
1	52-HA-761-1		
1	52-HB-761-1		
1	52-HC-761-1		
1	52-HD-761-1		
1	52-HE-761-1		
1	52-HF-761-1		
1	52-HG-761-1		
1	52-HH-761-1		
1	52-HI-761-1		
1	52-HJ-761-1		
1	52-HK-761-1		
1	52-HL-761-1		
1	52-HM-761-1		
1	52-HN-761-1		
1	52-HO-761-1		
1	52-HP-761-1		
1	52-HQ-761-1		
1	52-HR-761-1		
1	52-HS-761-1		
1	52-HT-761-1		
1	52-HU-761-1		
1	52-HV-761-1		
1	52-HW-761-1		
1	52-HX-761-1		
1	52-HY-761-1		
1	52-HZ-761-1		
1	52-IA-761-1		
1	52-IB-761-1		
1	52-IC-761-1		
1	52-ID-761-1		
1	52-IE-761-1		
1	52-IF-761-1		
1	52-IG-761-1		
1	52-IH-761-1		
1	52-II-761-1		
1	52-IJ-761-1		
1	52-IK-761-1		
1	52-IL-761-1		
1	52-IM-761-1		
1	52-IN-761-1		
1	52-IO-761-1		
1	52-IP-761-1		
1	52-IQ-761-1		
1	52-IR-761-1		
1	52-IS-761-1		
1	52-IT-761-1		
1	52-IU-761-1		
1	52-IV-761-1		
1	52-IW-761-1		
1	52-IX-761-1		
1	52-IY-761-1		
1	52-IZ-761-1		
1	52-JA-761-1		
1	52-JB-761-1		
1	52-JC-761-1		
1	52-JD-761-1		
1	52-JE-761-1		
1	52-JF-761-1		
1	52-JG-761-1		
1	52-JH-761-1		
1	52-JI-761-1		
1	52-JJ-761-1		
1	52-JK-761-1		
1	52-JL-761-1		
1	52-JM-761-1		
1	52-JN-761-1		
1	52-JO-761-1		
1	52-JP-761-1		
1	52-JQ-761-1		
1	52-JR-761-1		
1	52-JS-761-1		
1	52-JT-761-1		
1	52-JU-761-1		
1	52-JV-761-1		
1	52-JW-761-1		
1	52-JX-761-1		
1	52-JY-761-1		
1	52-JZ-761-1		
1	52-KA-761-1		
1	52-KB-761-1		
1	52-KC-761-1		
1	52-KD-761-1		
1	52-KE-761-1		
1	52-KF-761-1		
1	52-KG-761-1		
1	52-KH-761-1		
1	52-KI-761-1		
1	52-KJ-761-1		
1	52-KK-761-1		
1	52-KL-761-1		
1	52-KM-761-1		
1	52-KN-761-1		
1	52-KO-761-1		
1	52-KP-761-1		
1	52-KQ-761-1		
1	52-KR-761-1		
1	52-KS-761-1		
1	52-KT-761-1		
1	52-KU-761-1		
1	52-KV-761-1		
1	52-KW-761-1		
1	52-KX-761-1		
1	52-KY-761-1		
1	52-KZ-761-1		
1	52-LA-761-1		
1	52-LB-761-1		
1	52-LC-761-1		
1	52-LD-761-1		
1	52-LE-761-1		
1	52-LF-761-1		
1	52-LG-761-1		
1	52-LH-761-1		
1	52-LI-761-1		
1	52-LJ-761-1		
1	52-LK-761-1		
1	52-LL-761-1		
1	52-LM-761-1		
1	52-LN-761-1		
1	52-LO-761-1		
1	52-LP-761-1		
1	52-LQ-761-1		
1	52-LR-761-1		
1	52-LS-761-1		
1	52-LT-761-1		
1	52-LU-761-1		
1	52-LV-761-1		
1	52-LW-761-1		
1	52-LX-761		

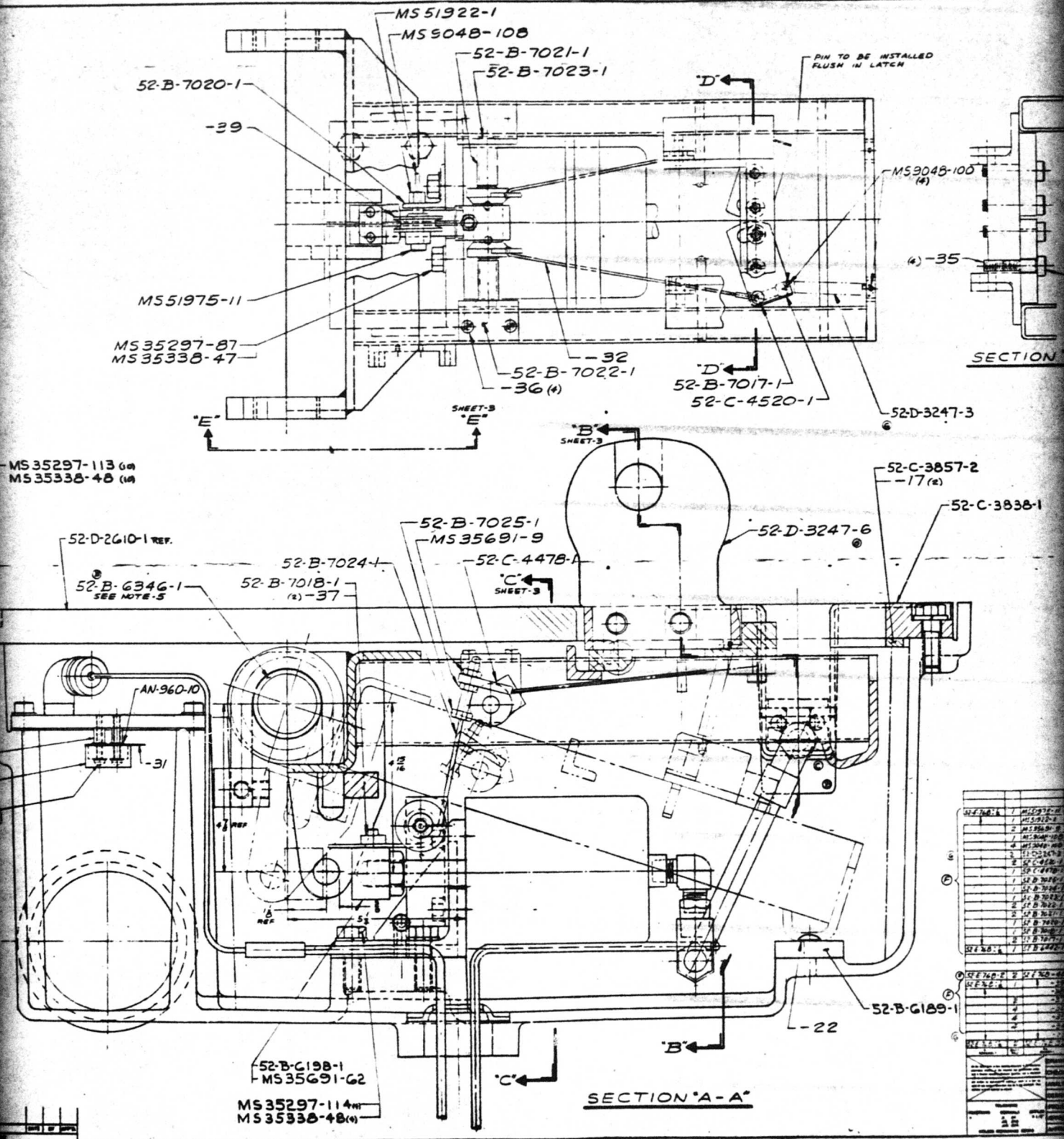
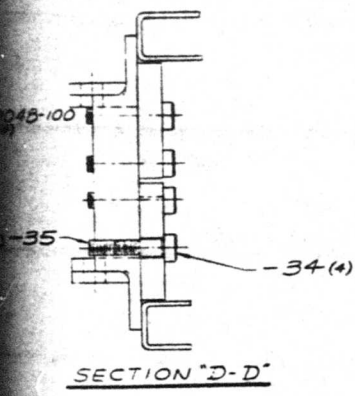
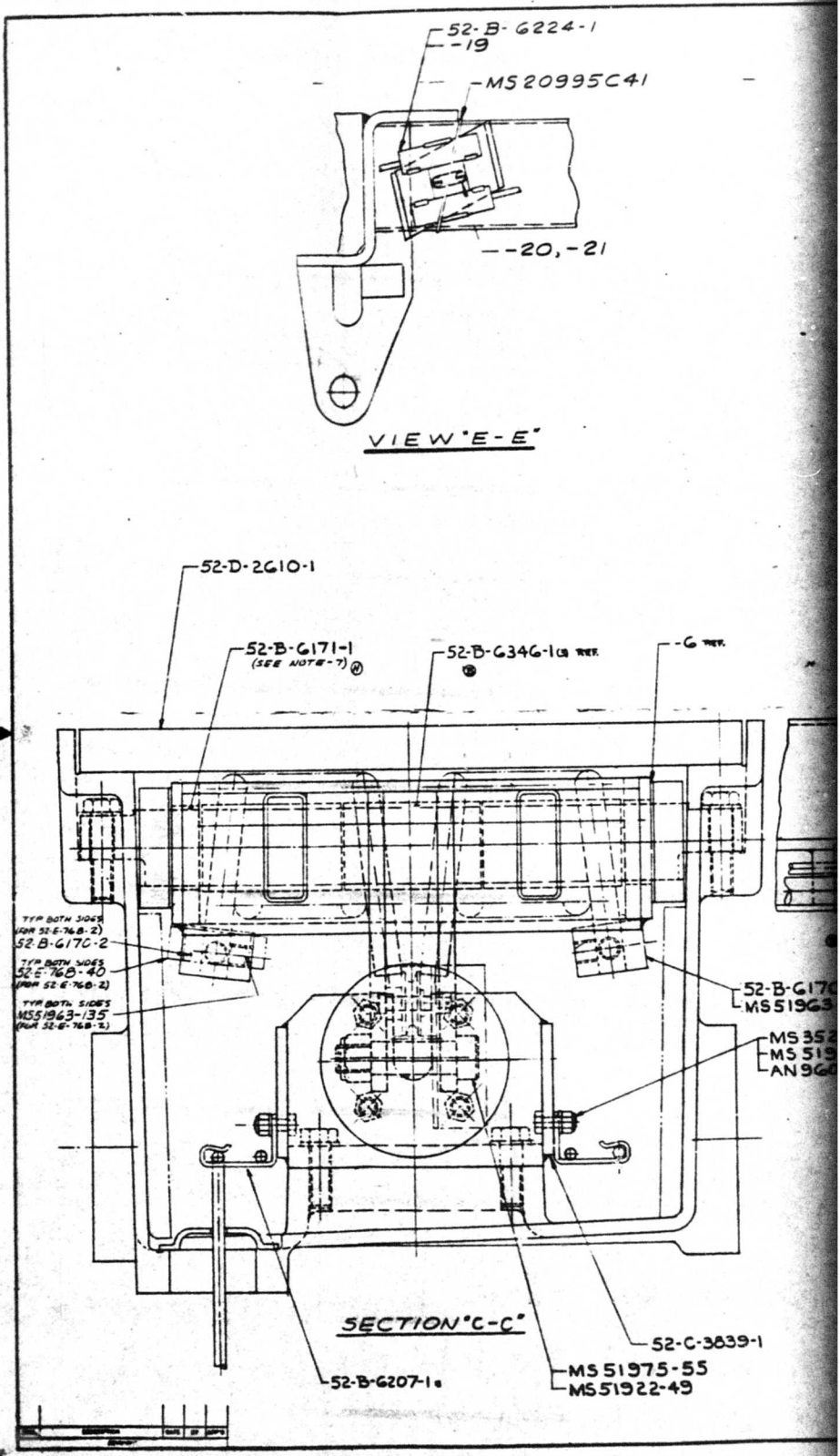

FIGURE 2 - STANDARD LATCH MECHANISM DESIGN

- NOTES
 1. BREAK ALL SHARP EDGES
 2. MOUNTING IS RECOMMENDED FOR SUPPORTING MANUFACTURING ALIGNMENT.
 3. FINISH PER



3247-3
 3857-2
 (2)
 -52-C-3838-1



REV	DESCRIPTION	DATE	BY	CHKD
1	ISSUED FOR PRODUCTION			
2	ISSUED FOR PRODUCTION			
3	ISSUED FOR PRODUCTION			
4	ISSUED FOR PRODUCTION			
5	ISSUED FOR PRODUCTION			
6	ISSUED FOR PRODUCTION			
7	ISSUED FOR PRODUCTION			
8	ISSUED FOR PRODUCTION			
9	ISSUED FOR PRODUCTION			
10	ISSUED FOR PRODUCTION			
11	ISSUED FOR PRODUCTION			
12	ISSUED FOR PRODUCTION			
13	ISSUED FOR PRODUCTION			
14	ISSUED FOR PRODUCTION			
15	ISSUED FOR PRODUCTION			
16	ISSUED FOR PRODUCTION			
17	ISSUED FOR PRODUCTION			
18	ISSUED FOR PRODUCTION			
19	ISSUED FOR PRODUCTION			
20	ISSUED FOR PRODUCTION			
21	ISSUED FOR PRODUCTION			
22	ISSUED FOR PRODUCTION			
23	ISSUED FOR PRODUCTION			
24	ISSUED FOR PRODUCTION			
25	ISSUED FOR PRODUCTION			
26	ISSUED FOR PRODUCTION			
27	ISSUED FOR PRODUCTION			
28	ISSUED FOR PRODUCTION			
29	ISSUED FOR PRODUCTION			
30	ISSUED FOR PRODUCTION			
31	ISSUED FOR PRODUCTION			
32	ISSUED FOR PRODUCTION			
33	ISSUED FOR PRODUCTION			
34	ISSUED FOR PRODUCTION			
35	ISSUED FOR PRODUCTION			
36	ISSUED FOR PRODUCTION			
37	ISSUED FOR PRODUCTION			
38	ISSUED FOR PRODUCTION			
39	ISSUED FOR PRODUCTION			
40	ISSUED FOR PRODUCTION			
41	ISSUED FOR PRODUCTION			
42	ISSUED FOR PRODUCTION			
43	ISSUED FOR PRODUCTION			
44	ISSUED FOR PRODUCTION			
45	ISSUED FOR PRODUCTION			
46	ISSUED FOR PRODUCTION			
47	ISSUED FOR PRODUCTION			
48	ISSUED FOR PRODUCTION			
49	ISSUED FOR PRODUCTION			
50	ISSUED FOR PRODUCTION			
51	ISSUED FOR PRODUCTION			
52	ISSUED FOR PRODUCTION			
53	ISSUED FOR PRODUCTION			
54	ISSUED FOR PRODUCTION			
55	ISSUED FOR PRODUCTION			
56	ISSUED FOR PRODUCTION			
57	ISSUED FOR PRODUCTION			
58	ISSUED FOR PRODUCTION			
59	ISSUED FOR PRODUCTION			
60	ISSUED FOR PRODUCTION			
61	ISSUED FOR PRODUCTION			
62	ISSUED FOR PRODUCTION			
63	ISSUED FOR PRODUCTION			
64	ISSUED FOR PRODUCTION			
65	ISSUED FOR PRODUCTION			
66	ISSUED FOR PRODUCTION			
67	ISSUED FOR PRODUCTION			
68	ISSUED FOR PRODUCTION			
69	ISSUED FOR PRODUCTION			
70	ISSUED FOR PRODUCTION			
71	ISSUED FOR PRODUCTION			
72	ISSUED FOR PRODUCTION			
73	ISSUED FOR PRODUCTION			
74	ISSUED FOR PRODUCTION			
75	ISSUED FOR PRODUCTION			
76	ISSUED FOR PRODUCTION			
77	ISSUED FOR PRODUCTION			
78	ISSUED FOR PRODUCTION			
79	ISSUED FOR PRODUCTION			
80	ISSUED FOR PRODUCTION			
81	ISSUED FOR PRODUCTION			
82	ISSUED FOR PRODUCTION			
83	ISSUED FOR PRODUCTION			
84	ISSUED FOR PRODUCTION			
85	ISSUED FOR PRODUCTION			
86	ISSUED FOR PRODUCTION			
87	ISSUED FOR PRODUCTION			
88	ISSUED FOR PRODUCTION			
89	ISSUED FOR PRODUCTION			
90	ISSUED FOR PRODUCTION			
91	ISSUED FOR PRODUCTION			
92	ISSUED FOR PRODUCTION			
93	ISSUED FOR PRODUCTION			
94	ISSUED FOR PRODUCTION			
95	ISSUED FOR PRODUCTION			
96	ISSUED FOR PRODUCTION			
97	ISSUED FOR PRODUCTION			
98	ISSUED FOR PRODUCTION			
99	ISSUED FOR PRODUCTION			
100	ISSUED FOR PRODUCTION			

4

270

SHEET-2 OF 3

SUPPORT BOX ASSEMBLY
 BAK-16
 52-E-76B-17
 SHEET-2 OF 3

NOTES
 1. BREAK ALL SHARP EDGES
 2. MOUNTING IS MOUNTED TO CASE WITHOUT
 MANUFACTURING ALLOWANCE
 3. PUNCH PER

**COPY AVAILABLE TO DDC DOES NOT
 PERMIT FULLY LEGIBLE PRODUCTION**

24-1
 0995C41
 0, -21

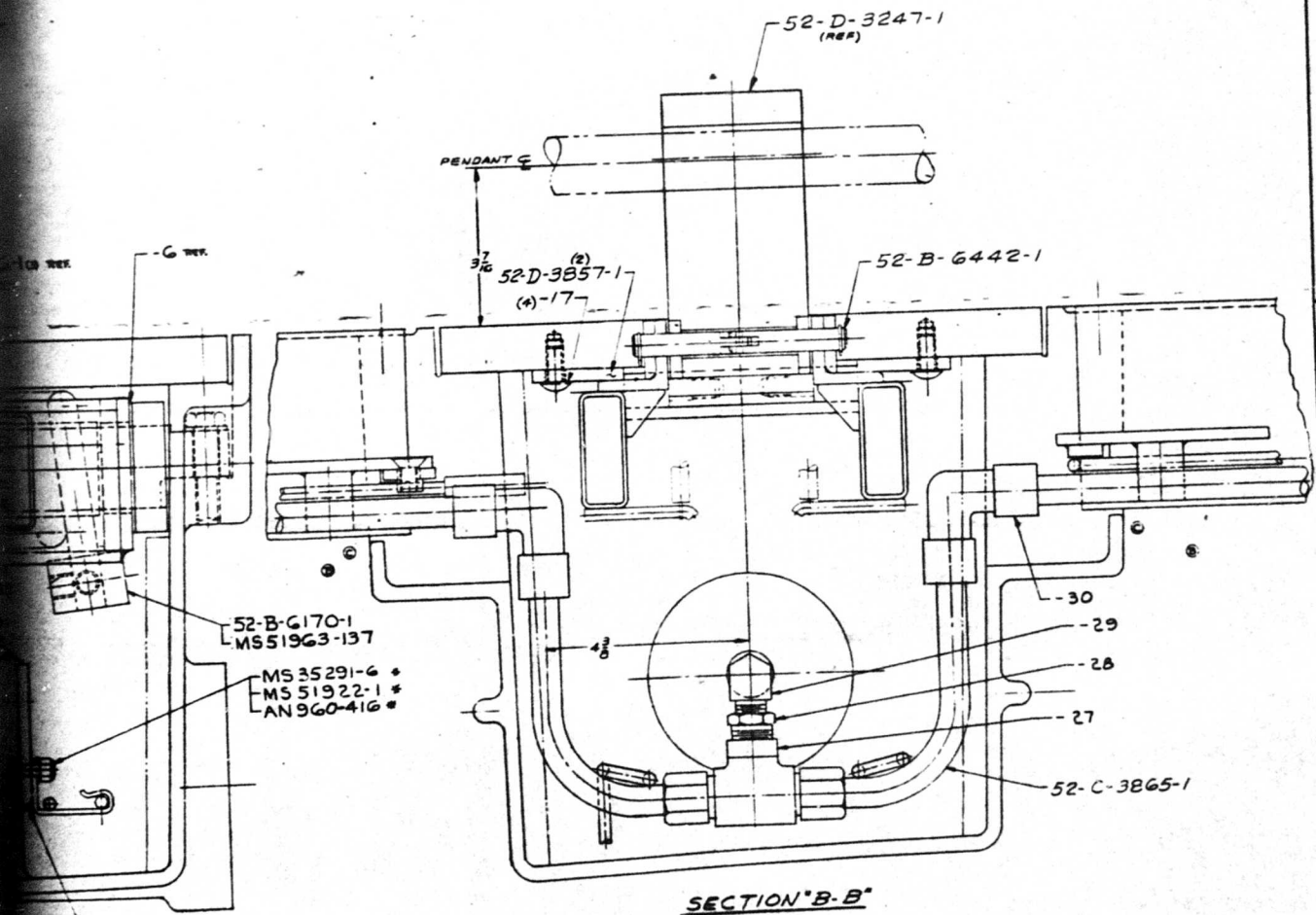

SECTION B-B

52-C-3839-1
 MS51975-55
 MS51922-49

NO.	REV.	DATE	BY	CHKD.	APP.	DESCRIPTION
1						ISSUED FOR PRODUCTION
2						REVISED
3						REVISED
4						REVISED
5						REVISED
6						REVISED
7						REVISED
8						REVISED
9						REVISED
10						REVISED

ENGINEER: [Signature]
 CHECKED: [Signature]
 DESIGNED: [Signature]
 DRAWN: [Signature]
 PROJECT: [Signature]
 SUPPORT: [Signature]
 APPROVED: [Signature]

SUPPORT BOX ASSEMBLY
 BAK-14
 SHEET 3 OF 3

5

D
C
B
A

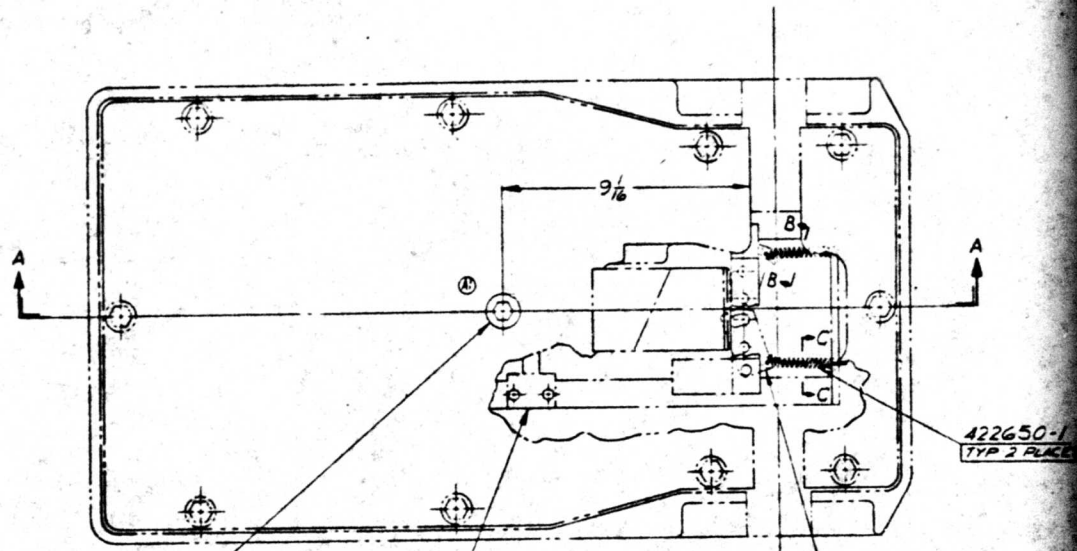

Ⓜ MS49005-12
TAP 1-11/2 NPT
THRU COVER

52-B-7022-1 (REF)
BRACKET

52-C-4520-1 (REF)
SUPPORT BLOCK LATCH

52-D-2610-1 (REF)
COVER-A

AN3-31
MS21044-N3
AN960-10L
3/64 DIA. THRU
TEMPLATE FROM
BRACKET 52-B-7022-1
TYP 4 PLACES

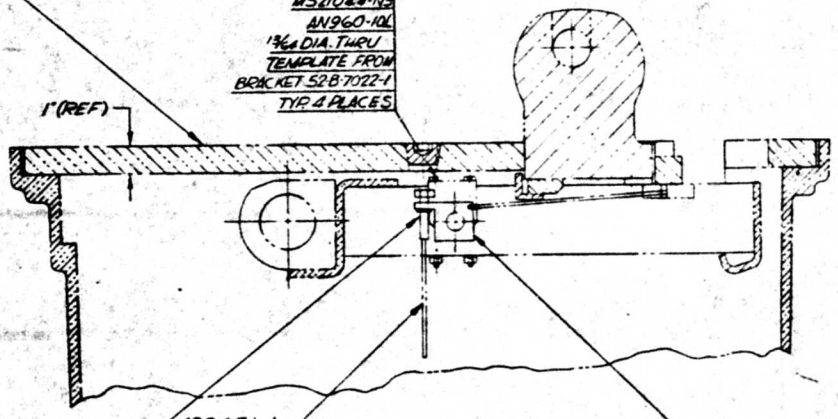

52-B-7024 (REF)
WIRE ROPE ASSY

SECTION A-A

517049-1

NOTES:

1. THE PURPOSE OF THIS DRAWING IS TO SHOW THE SUPPORT BLOCK LATCHING CABLE SUPPORT SYSTEM.
2. REF. NUMBERS CALLED OUT ON PART NUMBERS.
3. HITCH PIN CLIP - 2 IS SIMILAR WESTERN WIRE PRODUCTS 1415 S. 18TH ST. ST. LOUIS, MISSOURI 63104 CLIP NO. 3, (432 WIRE)

422650-1
TYP 2 PLACES

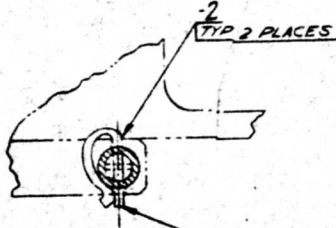

VIEW "B-B"
SCALE: 2/1

SNIP OFF END IF NECESSARY
DO NOT REMOVE MORE THAN 3/16 IN.

520-1 (REF)
BLOCK LATCH

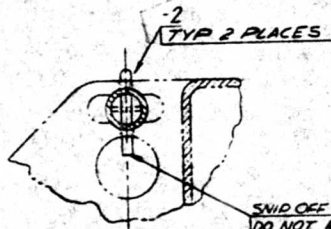

VIEW "C-C"
SCALE: 2/1

SNIP OFF END IF NECESSARY
DO NOT REMOVE MORE THAN 3/16 IN.

2

NOTES:

1. THE PURPOSE OF THIS DRAWING IS TO SHOW THE MODIFICATION TO THE SUPPORT BLOCK LATCHING MECHANISM OF THE BAK-14 CABLE SUPPORT SYSTEM.
2. REF. NUMBERS CALLED OUT ON DWG. ARE GULF-WESTERN PART NUMBERS.
3. LATCH PIN CLIP - 2 IS SIMILAR TO WESTERN WIRE PRODUCTS CO. 1415 S. 18TH ST. ST. LOUIS, MISSOURI 63104 CLIP NO. 3, (3/32 WIRE)

REV.	DESCRIPTION	DATE	APPROVED
1	1. P. 1. CLIP NO. 3, 3/32 WIRE. 2. REMOVED 1/4 DIA HOLE FROM COVER. 3. ADDED 1/4 DIA HOLE THRU COVER. 4. ON DWG. 1. DIM. 2. ADDED MESSAGE 2. PERSON TO PROVIDE PIPE PLUG FOR HOLE IN COVER. 3. 1/4"	11/73	HT

QTY	DESCRIPTION	STOCK	INTERNAL	SPECIFICATION	REF
1	MS6905-1 PLUG PIPE				
4	MS2044-3 NUT SELF-LOCKING				
4	AN360-100 WASHER				
4	AN3-31 BOLT				
1	517049-1 PIVOT ASSY				
1	422651-1 ADJUSTING SCREW				
2	422650-1 SPRING				
618978-1	618978-1 LATCH PIN CLIP				SEE NOTE 3
618978-1	618978-1 SUPPORT BOX ASSY MODIFICATION				

UNLESS OTHERWISE SPECIFIED DIMENSIONS ARE IN INCHES TOLERANCES ON FRACTIONS DECIMALS ANGLES 1/32 .010 .010	MECHANICAL FINISH SURFACE ROUGHNESS IN MICROINCHES ✓ SURFACE ROUGHNESS IN ACCORDANCE WITH ASA B46	DRAWN G. HALL 23 APR 73	ENGINEERING DEPARTMENT (8E) NAVY AIR ENGINEERING CENTER, PHILA., PA. 19112
CLASSIFICATION OF CHARACTERISTICS CRITICAL - C TO C MAJOR - M TO M MINOR - ALL OTHER CHARACTERISTICS	DESIGNED FOR BAK-14	CHECKED J. H. ... DATE 11/23/73	TITLE SUPPORT BOX ASSY MODIFICATION BAK-14 DRAWING NO. 618978
	APPROVED DATE 11/23/73	DATE 11/23/73	NO. 00020 73-1135 NOTED

FIGURE 8 - INTERIM-LATCH-MECHANISM DESIGN

3

WAS 0050

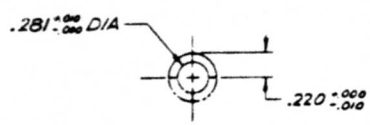

-9
 (MAKE FROM MS/7795-32)
 SCALE: 2/1

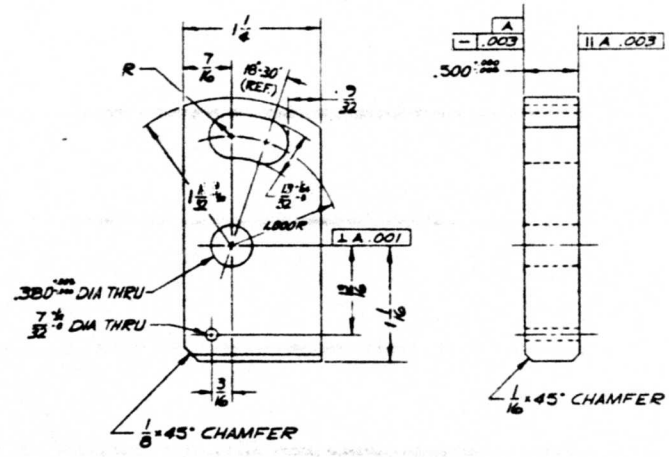
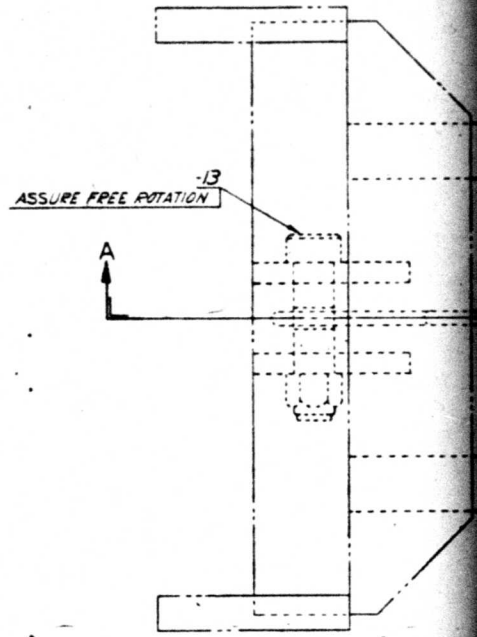

-12
 SCALE: 2/1

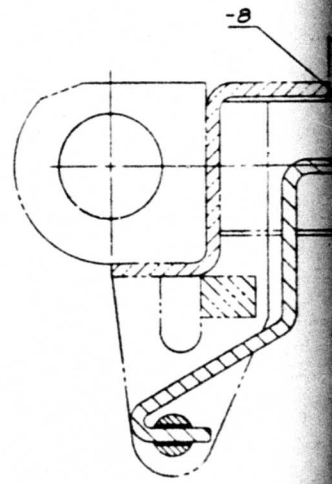

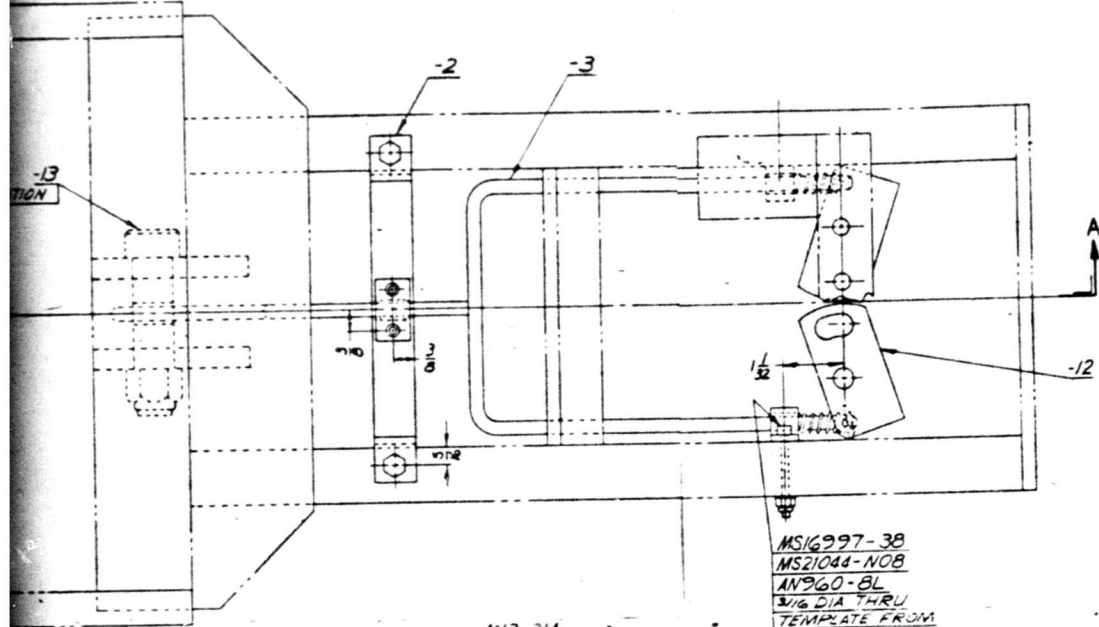

AN3-31A
MS21044-N3
AN960-10L
3/16 DIA THRU
TEMPLATE FROM
BRACKET -2
TYP 2 PLACES

MS16997-3B
MS21044-N0B
AN960-8L
3/16 DIA THRU
TEMPLATE FROM
BRACKET -6
TYP 4 PLACES

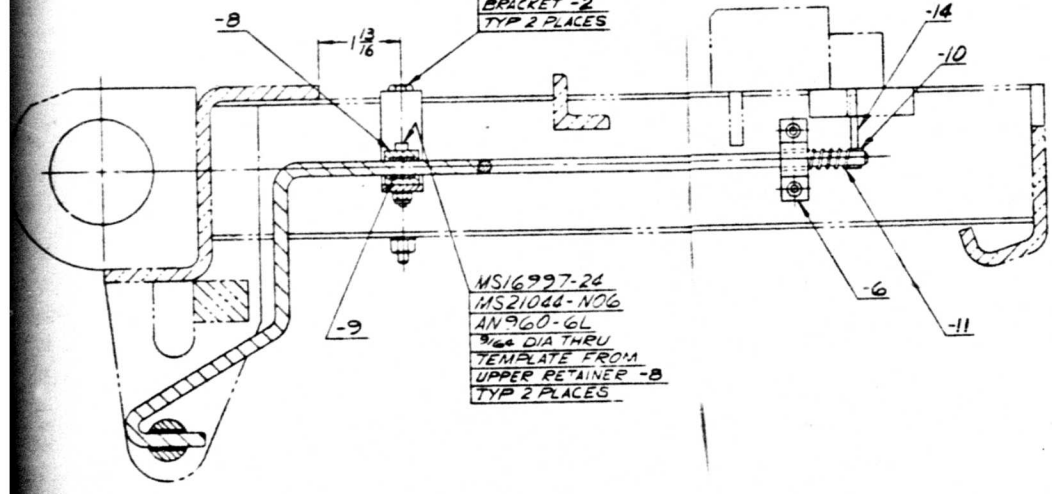

MS16997-24
MS21044-N06
AN960-6L
3/16 DIA THRU
TEMPLATE FROM
UPPER RETAINER -8
TYP 2 PLACES

3/32 DIA THRU (TYP)

SECTION A-A

2

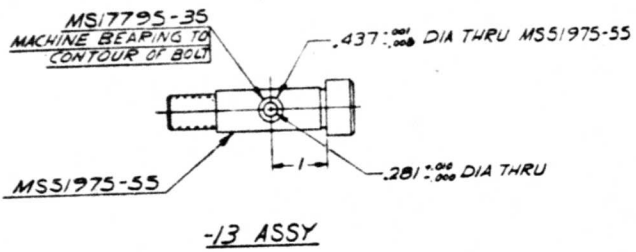

-13 ASSY

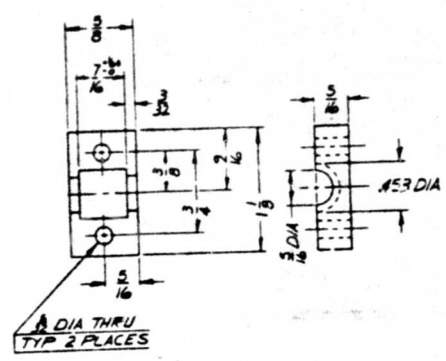

-8
SCALE 1/2/1

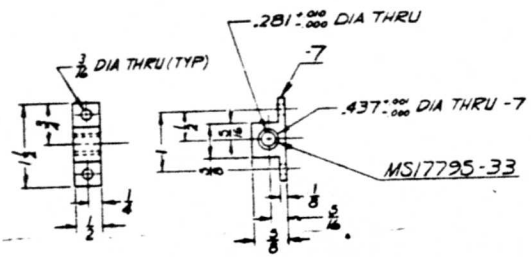

-6 ASSY

THIS PORTION OF -5

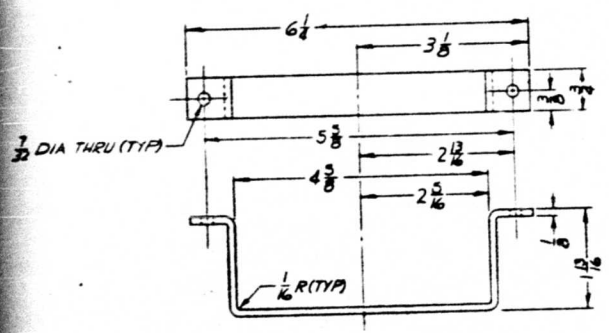
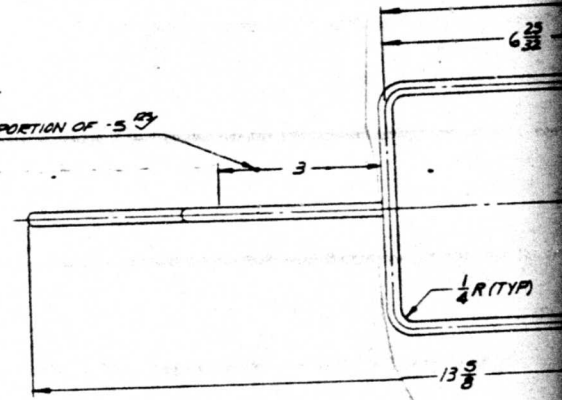

-2

FINISH THIS PORTION OF -5

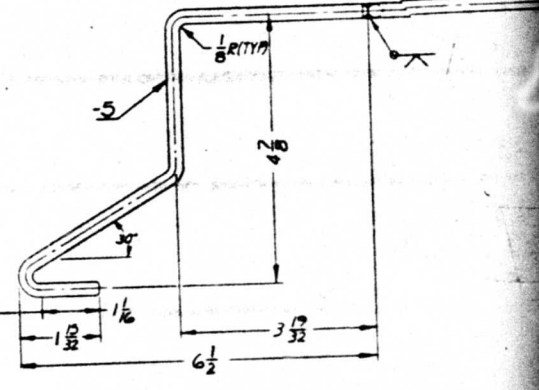

-3 WELDMENT

53 DIA

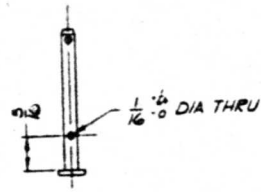

-14
 (MAKE FROM MS9462-19)
 SCALE: 1/1

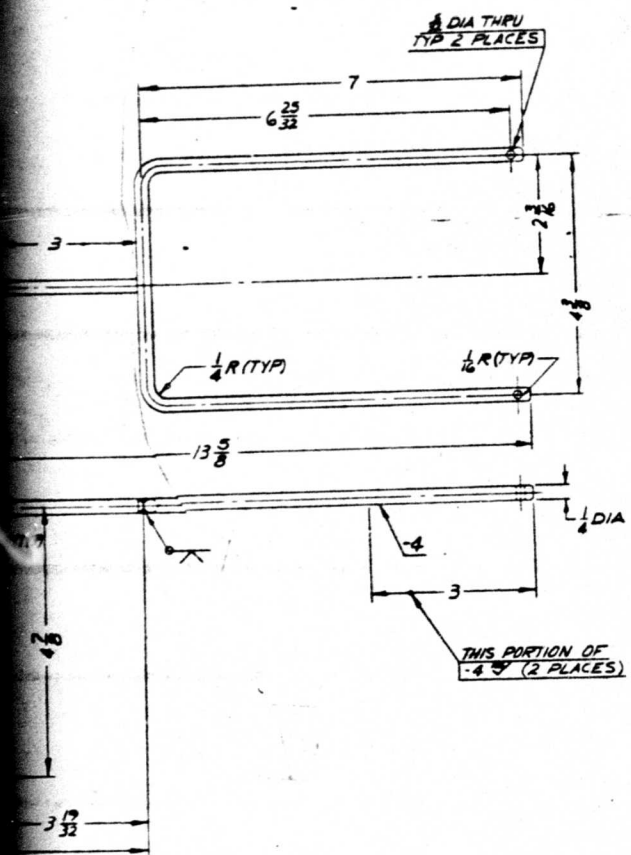

-3 WELDMENT

NOTES:

1. BREAK ALL SHARP EDGES.
2. STOCK SIZE IS NOMINAL WITHOUT ANY MANUFACTURING ALLOWANCE, FOR NAEC USE ONLY.
3. DIMENSIONING AND TOLERANCING ARE IN ACCORDANCE WITH USASI-Y14.5.
4. WELDING PROCESS SHALL BE IN ACCORDANCE WITH MIL-STD-278, CLASS 'M', EXCEPT THAT WELDING ROD SHALL BE IN ACCORDANCE WITH MPR 1400.
5. NITCH PIN CLIP -10 IS SIMILAR TO WESTERN WIRE PRODUCTS CO. #15 S. 18TH ST. ST. LOUIS, MISSOURI 63104 CLIP No. #21, (364 WIRE)
6. IDENTIFICATION MARKING SHALL BE IN ACCORDANCE WITH MIL-STD-130, INCLUDING CONTRACT No.
7. COMPRESSION SPRING SHALL MEET THE FOLLOWING REQUIREMENTS:
 - a. MATERIAL: STEEL MUSIC WIRE PER QQ-W-470, CADMIUM PLATED PER QQ-P-416.
 - b. ENDS: SQUARED AND GROUND
 - c. SPRING RATE: 18.8^{lb}/in = 10%.
 - d. FREE LENGTH: 1 1/8 IN
 - e. OUTSIDE DIAMETER: .360
 - f. WIRE DIAMETER: .040 IN
 POSSIBLE SOURCE OF SUPPLY:
 LEE SPRING COMPANY, INC.
 30 MAIN STREET
 BROOKLYN, NEW YORK 11201
 P/N LC-040E-9
8. MATERIAL SHALL BE MIL-S-18729 CL A. HEAT TREAT IN ACCORDANCE WITH MIL-H-6875 TO RHN C26 TO C32.
9. CADMIUM PLATE -2 -3 -7 -8 -1 -12 PER QQ-P-416. ALL DIMENSIONS ARE AFTER PLATING.
10. CAUTION: WITH SYSTEM IN RAISED "UP" POSITION (NO AIR PRESSURE), SUPPORT ARM IS SPRING-LOADED UP AGAINST BOX COVERS. BEFORE REMOVING COVER, READ INSTRUCTIONS ON PAGE 44 IN GULF-WESTERN RESEARCH AND DEVELOPMENT CENTER MANUAL P-3986.

CLASSIFICATION OF CHARACTERISTICS	
CRITICAL	- C TO C
MAJOR	- M TO M
MINOR	- ALL OTHER CHARACTERISTICS

UNLESS OTHERWISE SPECIFIED, DIMENSIONS ARE IN INCHES. TOLERANCES ON FRACTIONS DECIMALS ARE: 1/16 .004 .004

FIGURE 10 - FINAL LATCH

4

NOTES:

1. BREAK ALL SHARP EDGES.
2. STOCK SIZE IS NOMINAL WITHOUT ANY MANUFACTURING ALLOWANCE, FOR NAEC USE ONLY.
3. DIMENSIONING AND TOLERANCING ARE IN ACCORDANCE WITH USA SI-Y14.5.
4. WELDING PROCESS SHALL BE IN ACCORDANCE WITH MIL-STD-278, CLASS 'M', EXCEPT THAT WELDING ROD SHALL BE IN ACCORDANCE WITH MPR 1400.
5. HITCH PIN CLIP -10 IS SIMILAR TO WESTERN WIRE PRODUCTS CO. MISS. 18TH ST. ST. LOUIS, MISSOURI 63104 CLIP No. #21, (#64 WIRE)
6. IDENTIFICATION MARKING SHALL BE IN ACCORDANCE WITH MIL-STD-130, INCLUDING CONTRACT No.
7. COMPRESSION SPRING SHALL MEET THE FOLLOWING REQUIREMENTS:
 - a. MATERIAL: STEEL MUSIC WIRE PER QQ-W-470, CADMIUM PLATED PER QQ-P-416.
 - b. ENDS: SQUARED AND GROUND
 - c. SPRING RATE: 18.8 ^{lb}/_{in} ± 10%
 - d. FREE LENGTH: ^{1.76}/_{in}
 - e. OUTSIDE DIAMETER: .360
 - f. WIRE DIAMETER: .040
 POSSIBLE SOURCE OF SUPPLY:
 LEE SPRING COMPANY, INC.
 30 MAIN STREET
 BROOKLYN, NEW YORK 11201
 P/N LC-040E-9
8. MATERIAL SHALL BE MIL-S-18729 CL A. HEAT TREAT IN ACCORDANCE WITH MIL-H-6875 TO RHN C26 TO C32.
9. CADMIUM PLATE -2 -3 -7 -8 -1 -12 PER QQ-P-416. ALL DIMENSIONS ARE AFTER PLATING.
10. CAUTION: WITH SYSTEM IN RAISED "UP" POSITION (NO AIR PRESSURE), SUPPORT ARM IS SPRING-LOADED UP AGAINST BOX COVERS. BEFORE REMOVING COVER, READ INSTRUCTIONS ON PAGE 44 IN GULF-WESTERN RESEARCH AND DEVELOPMENT CENTER MANUAL P-3986.

COPY AVAILABLE TO DDC DOES NOT PERMIT FULLY LEGIBLE PRODUCTS.

MISC 09708	QTY	DESCRIPTION	STOCK	MATERIAL	SPECIFICATION	REF
1	1	MS1975-19 SCREW, SHOULDER				
2	2	MS2044-N3 NUT, SELF-LOCKING				
4	4	MS2044-N3 NUT, SELF-LOCKING				
2	2	MS2044-N3 NUT, SELF-LOCKING				
1	1	MS17795-33 SLEEVE BEARING				
1	1	MS17795-33 SLEEVE BEARING				
4	4	MS16977-26 SCREW				
2	2	MS16977-26 SCREW				
2	2	AN360-10L WASHER				
4	4	AN360-8L WASHER				
2	2	AN360-4L WASHER				
2	2	AN3-3/16 BOLT				
2	2	41 PIN (MAKE FROM MS9462-19)				
1	1	13 BOLT ASSY				
2	2	6 LATCH 2" x 1/4" STEEL SEE NOTE 8				
2	2	11 SPRING SEE NOTE 7				
2	2	10 HITCH PIN CLIP SEE NOTE 5				
2	2	7 BEARING (MAKE FROM MS17795-32)				
2	2	8 RETAINER 3/8" x 3/8" x 1/4" STEEL MIL-S-22698 TY I, CL A				
1	1	7 BRACKET 2" x 1/4" STEEL MIL-S-22698 TY I, CL A				
2	2	6 BRACKET ASSY				
3	3	5 ROD 1/4 DIA x 1/8" STEEL MIL-S-20166 TY I, CL A				
1	1	4 FORK 1/4 DIA x 3/8" STEEL MIL-S-20166 TY I, CL A				
1	1	3 ROD WELDMENT 1/8" x 1/4" x 3/4" STEEL MIL-S-22698 TY I, CL A				
1	1	2 BRACKET				
MISC 09708 REDESIGNED LATCH MECHANISM						

UNLESS OTHERWISE SPECIFIED DIMENSIONS ARE IN INCHES TOLERANCES ON FRACTIONS DECIMALS ANGLES
 ± .010 ± .014
 THESE DOCUMENTS ALSO ARE A PART OF THIS DRAWING.

CLASSIFICATION OF CHARACTERISTICS
 CRITICAL - C TO C
 MAJOR - M TO M
 MINOR - ALL OTHER CHARACTERISTICS

MECHANICAL FINISH SURFACE ROUGHNESS IN MICROINCHES
 ✓ SURFACE ROUGHNESS IN ACCORDANCE WITH ASH 58

DESIGNED BY BAK-14
 CHECKED [Signature] 5/11/74
 ANALYZED [Signature] 5/11/74
 SUPERVISOR [Signature] 5/11/74
 APPROVED [Signature] 5/11/74
 DATE 5/11/74
 SIZE H
 CODE BENT NO. 80020
 TITLE LATCH MECHANISM REDESIGNED SUPPORT BOX ASSY
 DRAWING NO. MISC 09708
 SCALE FULL 1 AS NOTED

FIGURE 10 - FINAL LATCH MECHANISM DESIGN

5

DISTRIBUTION

DDC - 2

NAVAIRENGCEN (991) - 1
(91111)(TISCA)) - 2NAVAIRSYSCOM (AIR-06) - 1
(AIR-53723) - 1
(AIR-50174) - 1
(AIR-954) - 2

AFSC (SDAE), ANDREWS AFB - 4

CSAF (XOOFSA) - 2

COMOPTEVFOR (CODE 734)

