

UNCLASSIFIED

AD NUMBER

ADB009687

LIMITATION CHANGES

TO:

Approved for public release; distribution is unlimited.

FROM:

Distribution authorized to U.S. Gov't. agencies only; Test and Evaluation; DEC 1975. Other requests shall be referred to Federal Aviation Administration, ARD-60, 800 Independence Avenue, SW, Washington, DC 20591.

AUTHORITY

faa ltr, 7 jul 1976

THIS PAGE IS UNCLASSIFIED

THIS REPORT HAS BEEN DELIMITED  
AND CLEARED FOR PUBLIC RELEASE  
UNDER DOD DIRECTIVE 5200.20 AND  
NO RESTRICTIONS ARE IMPOSED UPON  
ITS USE AND DISCLOSURE,

DISTRIBUTION STATEMENT A

APPROVED FOR PUBLIC RELEASE;  
DISTRIBUTION UNLIMITED,

FAA-RD-75-194-1

1-2 FC

# JTIDS 960 TO 1215 MHz RADIONAVIGATION BAND COMPATIBILITY TEST RESULTS

12

AD B 009687

IIT Research Institute  
Under Contract to  
**DEPARTMENT OF DEFENSE**  
Electromagnetic Competibility Analysis Center  
Annapolis, Maryland 21402



December 1975

FINAL REPORT

DDC  
RECEIVED  
MAR 16 1976  
RECEIVED

A

AD No. 1  
DDC FILE COPY

Approved for U.S. Government only. This document is exempted from public availability because of requirements in the JTIDS Security Classification Guide. Transmittal of this document outside the U.S. Government must have prior approval of the Federal Aviation Administration (ARD-60).

Prepared for

**U.S. DEPARTMENT OF TRANSPORTATION**  
**FEDERAL AVIATION ADMINISTRATION**  
Systems Research & Development Service  
Washington, DC 20591

FAA-RD-75-1941

This document is disseminated under the sponsorship of the Department of Transportation in the interest of information exchange. The United States Government assumes no liability for its contents or use thereof.

TECHNICAL REPORT STANDARD TITLE PAGE

1. Report No. <b>19</b> <del>ECAC-PR-75-067</del> FAA-RD-75-194-I	2. Government Accession No.	3. Recipient's Catalog No.	
4. Title and Subtitle <b>6</b> JTIDS 960 TO 1215 MHz RADIONAVIGATION BAND COMPATIBILITY TEST RESULTS ✓		5. Report Date <b>10</b> Dec <del>1975</del> 1975	6. Performing Organization Code
7. Author(s) <b>10</b> John/Patrick Dan/Craig		8. Performing Organization Report No. ECAC-PR-75-067 ✓	
9. Performing Organization Name and Address DoD Electromagnetic Compatibility Analysis Center North Severn Annapolis, Maryland 21402 <b>12/189 p. 4</b>		10. Work Unit No. Task Assignment 24	11. Contract or Grant No. DOT-FA70 WAI-175 ✓
12. Sponsoring Agency Name and Address Department of Transportation Federal Aviation Administration Systems Research and Development Service Washington, D.C. 20591		13. Type of Report and Period Covered <b>9</b> Final Report, Apr - Jun 75 14. Sponsoring Agency Code	
15. Supplementary Notes Performed for the Frequency Management Division, Spectrum Plans and Programs Branch, FAA.			
16. Abstract <b>15</b> <del>FAA-75-194-I</del> <b>16</b> <del>AF-649E</del> <del>DOT-FA70WAI-175</del> Sponsored by the FAA, the Electromagnetic Compatibility Analysis Center conducted tests from April through June, 1975 at the National Aviation Facilities Center to investigate the electromagnetic compatibility between existing systems in the 960-1215 MHz radionavigation band and four candidate signal formats of the Joint Tactical Information Distribution System (JTIDS).  This report documents the test procedures, and contains graphical representations of the data along with an interpretation of the test results.			
17. Key Words JOINT TACTICAL INFORMATION DISTRIBUTION SYSTEM (JTIDS) TIME DIVISION MULTIPLE ACCESS (TDMA) SPREAD SPECTRUM TACAN/DME/IFF ELECTROMAGNETIC COMPATIBILITY		18. Distribution Statement Approved for U. S. Government only. This document is exempted from public availability because of requirements in the JTIDS Security Classification Guide. Transmittal of this document outside the U. S. Government must have prior approval of the Federal Aviation Administration (ARD-60).	
19. Security Classif. (of this report) UNCLASSIFIED	20. Security Classif. (of this page) UNCLASSIFIED	21. No. of Pages 196	22. Price

-A-

175 300

net

# METRIC CONVERSION FACTORS

Approximate Conversions to Metric Measures				Approximate Conversions from Metric Measures			
Symbol	When You Know	Multiply by	To Find	Symbol	When You Know	Multiply by	To Find
<b>LENGTH</b>							
in	inches	2.5	centimeters	mm	millimeters	0.04	inches
ft	feet	30	centimeters	cm	centimeters	0.4	inches
yd	yards	0.9	meters	m	meters	3.3	feet
mi	miles	1.6	kilometers	km	kilometers	1.1	yards
						0.6	miles
<b>AREA</b>							
in <sup>2</sup>	square inches	6.5	square centimeters	cm <sup>2</sup>	square centimeters	0.16	square inches
ft <sup>2</sup>	square feet	0.09	square meters	m <sup>2</sup>	square meters	1.2	square yards
yd <sup>2</sup>	square yards	0.8	square meters	km <sup>2</sup>	square kilometers	0.4	square miles
mi <sup>2</sup>	square miles	2.6	square kilometers	ha	hectares (10,000 m <sup>2</sup> )	2.5	acres
	acres	0.4	hectares				
<b>MASS (weight)</b>							
oz	ounces	28	grams	g	grams	0.035	ounces
lb	pounds	0.45	kilograms	kg	kilograms	2.2	pounds
	short tons (2000 lb)	0.9	tonnes	t	tonnes (1000 kg)	1.1	short tons
<b>VOLUME</b>							
tsp	teaspoons	5	milliliters	ml	milliliters	0.03	fluid ounces
Tbsp	tablespoons	15	milliliters	ml	milliliters	2.1	pints
fl oz	fluid ounces	30	milliliters	ml	milliliters	1.06	quarts
c	cups	0.24	liters	l	liters	0.26	gallons
pt	pints	0.47	liters	l	liters	35	cubic feet
qt	quarts	0.95	liters	m <sup>3</sup>	cubic meters	1.3	cubic yards
gal	gallons	3.8	liters	m <sup>3</sup>	cubic meters		
ft <sup>3</sup>	cubic feet	0.03	cubic meters	m <sup>3</sup>	cubic meters		
yd <sup>3</sup>	cubic yards	0.76	cubic meters	m <sup>3</sup>	cubic meters		
<b>TEMPERATURE (exact)</b>							
°F	Fahrenheit temperature	5/9 (after subtracting 32)	Celsius temperature	°C	Celsius temperature	9/5 (then add 32)	Fahrenheit temperature

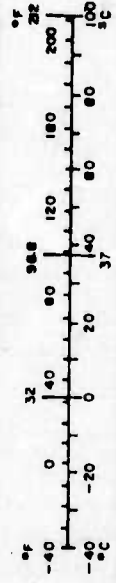
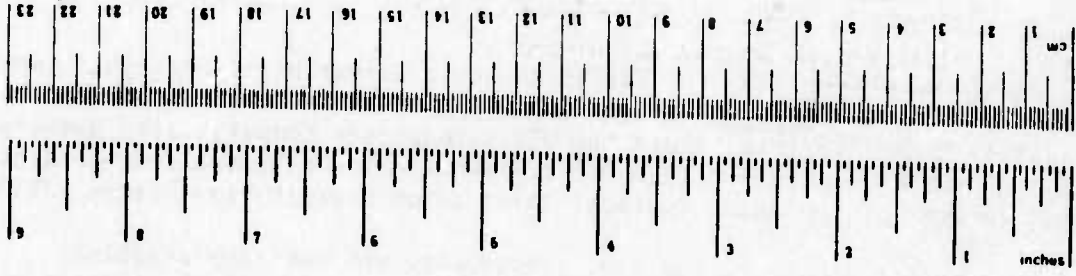

\*1 in = 2.54 exactly. For other exact conversions and more data and tables, see NBS Misc. Publ. 286, Units of Weights and Measures, Price \$2.25. SD Catalog No. C13.1-256

EXECUTIVE SUMMARY

The Electromagnetic Compatibility Analysis Center was tasked by the Federal Aviation Administration to conduct a test at the National Aviation Facilities Experimental Center for the purpose of examining the compatibility of the Joint Tactical Information Distribution System (JTIDS) with equipment operating in the 960-1215 MHz radionavigation band.

The effects of four different JTIDS waveforms were examined with respect to the operation of five types of systems: TACAN/DME interrogators, TACAN/DME beacons, IFF transponders, IFF interrogators, and the Digital Data Broadcast System. In this report the test procedures are documented, the data are compiled and interpreted, and results are provided.

There is no evidence that the JTIDS narrowband mode will degrade the common civilian systems. With respect to the JTIDS wideband mode, at least one receiver in each of the five types tested showed some degree of susceptibility. There is, however, no stated criterion for assessing the susceptibility of TACAN/DME/IFF systems to wideband, frequency-hopped energy. The actual degradation to these systems will depend on the desired-signal level and on the JTIDS waveform, effective radiated power and duty cycle.

The results are presented in terms of the effect of the JTIDS signal level on operational parameters such as distance separation and reply efficiency, for the conditions tested. No attempt was made to formulate operational restrictions for the systems involved.

APPROVED FOR	
DATE	DATE
BY	SUB SECTION
UNCLASSIFIED	
JUSTIFICATION	
DISTRIBUTION/AVAILABILITY CODES	
USL	AVAIL. and/or SPECIAL
13	

PREFACE

The Electromagnetic Compatibility Analysis Center (ECAC) is a Department of Defense facility, established to provide advice and assistance on electromagnetic compatibility matters to the Secretary of Defense, the Joint Chiefs of Staff, the military department and other DoD components. The Center, located at North Severn, Annapolis, Maryland 21402, is under executive control of the Office of the Secretary of Defense, Director of Telecommunications and Command and Control Systems and the Chairman, Joints Chiefs of Staff, or their designees, who jointly provide policy guidance, assign projects, and establish priorities. ECAC functions under the direction of the Secretary of the Air Force and the management and technical direction of the Center are provided by military and civil service personnel. The technical operations function is provided through an Air Force sponsored contract with the IIT Research Institute (IITRI).

This report was prepared for the Systems Research and Development Service of the Federal Aviation Administration in accordance with Interagency Agreement DOT-FA70WAI-175, as part of AF Project 649E under Contract F-19628-76-C-0017, by the staff of the IIT Research Institute at the Department of Defense Electromagnetic Compatibility Analysis Center.

*This report was a team effort and required the cooperation of many dedicated people. Recognition should be given to Arthur Radice who performed the actual testing and William Vint who processed the data. The efforts of the Hughes, Boeing, and NADC personnel who worked overtime and on weekends to insure the timely completion of the project were particularly gratifying. Finally, the work of Robert Flint in coordinating NAFEC support contributed greatly to the success of the project.*

To the extent possible, all abbreviations and symbols used in this report are taken from American Standard Y10.19 (1967) "Units Used in Electrical Science and Electrical Engineering" issued by the United States of America Standards Institute.

Reviewed by:

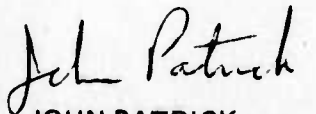

JOHN PATRICK  
Project Engineer, IITRI

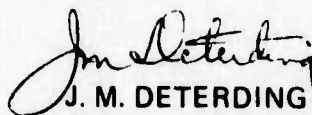

J. M. DETERDING  
Director of Contractor Operations

Approved by:



R. E. BEERY  
Colonel, USAF  
Director



M. A. SKEATH  
Special Projects  
Deputy Director

TABLE OF CONTENTS

<u>Subsection</u>	<u>Page</u>
SECTION 1	
INTRODUCTION	
BACKGROUND . . . . .	7
OBJECTIVES . . . . .	7
APPROACH . . . . .	8
SECTION 2	
SYSTEM DESCRIPTIONS	
TACAN/DME SYSTEM DESCRIPTION . . . . .	9
TACAN Beacon Operation . . . . .	11
Airborne Distance Determination . . . . .	11
TACAN Beacon Bearing Determination . . . . .	12
IFF/SSR SYSTEM DESCRIPTION . . . . .	13
IFF/SSR Interrogation Modes . . . . .	13
Defruiter/Decoder Operation . . . . .	16
DIGITAL DATA BROADCAST SYSTEM . . . . .	18
JTIDS SYSTEM DESCRIPTION . . . . .	20
SECTION 3	
TEST PROCEDURES	
INTRODUCTION . . . . .	31
TACAN BEACON TEST . . . . .	31
Sample Size . . . . .	31
Beacon Set-up . . . . .	33
TDMA Waveform Generator Setup . . . . .	33
Reply Efficiency Test . . . . .	33
Beacon Loading Test . . . . .	38
DIGITAL DATA BROADCAST . . . . .	41
DDB Sensitivity . . . . .	46
TACAN/DME INTERROGATOR TEST . . . . .	48
Sensitivity Measurement . . . . .	51
IFF TRANSPONDER . . . . .	53
Sensitivity Measurement . . . . .	53
IFF INTERROGATOR . . . . .	55
ARTCBI-4 Test . . . . .	55
Sensitivity Measurement . . . . .	56
ARTCBI-3 Test . . . . .	57

TABLE OF CONTENTS (Continued)

<u>Subsection</u>	<u>Page</u>
SECTION 4	
INTERPRETATION OF DATA	
INTRODUCTION . . . . .	61
TACAN BEACON TEST RESULTS . . . . .	61
Reply Efficiency Test . . . . .	61
Beacon-Loading Test . . . . .	66
TACAN/DME INTERROGATOR RESULTS . . . . .	68
Interference Trends . . . . .	71
DIGITAL DATA BROADCAST RESULTS . . . . .	74
IFF TRANSPONDER RESULTS . . . . .	77
IFF INTERROGATOR TEST RESULTS . . . . .	79
Video Photographs . . . . .	83
ARTCBI-3 . . . . .	83

SECTION 5

RESULTS

INTRODUCTION . . . . .	85
TACAN BEACON TESTS . . . . .	85
TACAN/DME INTERROGATOR TESTS . . . . .	85
DIGITAL DATA BROADCAST TESTS . . . . .	86
ATCRBS TRANSPONDER TESTS . . . . .	86
ATCRBS INTERROGATOR TESTS . . . . .	87
ARTCBI-4 . . . . .	87
ARTCBI-3 . . . . .	87

LIST OF ILLUSTRATIONS

<u>Figure</u>		
1	TACAN/IFF receiving channel/frequency allocations . . . . .	10
2	General configuration of IFF/SSR equipments . . . . .	14
3	IFF/SSR interrogation characteristics . . . . .	15
4	IFF/SSR reply characteristics . . . . .	17
5	Reply mode 2 or 3/A for code 2654 . . . . .	18
6	X and Y mode data coding for DDB . . . . .	19
7	Overall data structure for two successive 24-bit words . . . . .	20
8	JTIDS time slot structure . . . . .	21

TABLE OF CONTENTS (Continued)

LIST OF ILLUSTRATIONS (Continued)

<u>Figure</u>		<u>Page</u>
9	TDMA spectrums, 980 MHz center, 10 MHz/div, 10 dB/div, 0 dBm ref. . . . .	24
10	TDMA spectrums, 980 MHz center, 10 MHz/div, 10 dB/div, 0 dBm ref. . . . .	25
11	TDMA entire band spectrum: 1060 MHz center, 20 MHz/div, 10 dB/div, 0 dBm ref. spurious spectrum: 1530 MHz center, 200 MHz/div, 10 dB/div, +10 dBm ref. . . . .	26
12	TDMA spectrum of low band edge, 950 MHz center 5 MHz/div, 10 dB/div, 0 dBm ref. . . . .	27
13	TDMA spectrum of high band edge, 1220 MHz center, 5 MHz/div, 10 dB/div, 0 dBm ref. . . . .	28
14	TDMA spectrum of 1030 MHz notch, 1030 MHz center, 5 MHz/div, 10 dB/div, 0 dBm ref. . . . .	29
15	TDMA spectrum of 1090 MHz notch, 1090 MHz center, 5 MHz/div, 10 dB/div, 0 dBm ref. . . . .	30
16	TACAN beacon reply efficiency test . . . . .	35
17	TDMA RF coupling network . . . . .	36
18	Beacon receiver sensitivity data . . . . .	37
19	TACAN beacon loading test (fixed reply) . . . . .	39
20	TACAN beacon loading test (variable reply) . . . . .	42
21	Digital data broadcast test setup . . . . .	43
22	Digital data broadcast receiver sensitivity data . . . . .	47
23	TACAN/DME interrogator test setup . . . . .	50
24	Special NARCO DME 190 test set-up . . . . .	51
25	IFF transponder test setup . . . . .	54
26	ARTCBI-4 test setup . . . . .	57
27	ARTCBI-4 receiver sensitivity data . . . . .	59
28	ARTCBI-3 test setup . . . . .	60
29	AN/GRN-9C beacon reply efficiency results for TDMA duty factor of 50% . . . . .	64
30	AN/GRN-9C beacon change in reply efficiency results for TDMA duty factor of 50% . . . . .	65
31	RTB-2 beacon loading results for waveform 3A (50% TDMA duty cycle, desired-signal level MDS + 1 dB, PRF 500 pps). . . . .	67
32	King 7000 SN 1993 test results for 50% TDMA duty factors . . . . .	69
33	King 7000 SN 1993 test results continued . . . . .	70
34	Digital data broadcast test results for desired signal level of MDS + 2 dB and wideband TDMA duty factor of 50% . . . . .	75

TABLE OF CONTENTS (Continued)

LIST OF ILLUSTRATIONS (Continued)

<u>Figure</u>		<u>Page</u>
35	Digital data broadcast test results for desired signal level of MDS + 10 dB and wideband TDMA duty factor of 50% . . . . .	76
36	Regency 505I test results (desired signal - MDS + 3 dB, wideband TDMA duty cycle - 50%) . . . . .	78
37	ARTCBI-4 synchronous reply count data for desired signal level of MDS + 3 dB and a wideband TDMA duty factor of 50% . . . . .	80
38	ARTCBI-4 spurious reply count data for wideband TDMA duty cycle of 50% . . . . .	81

LIST OF TABLES

<u>Table</u>		
1	EQUIPMENT TESTED AT NAFEC . . . . .	32
2	TACAN/DME INTERROGATOR SENSITIVITY DATA . . . . .	49
3	IFF TRANSPONDER MDS LEVELS . . . . .	55
4	ARTCBI-4 MDS LEVELS (dBm) . . . . .	58
5	SUMMARY OF TACAN BEACON REPLY EFFICIENCY TEST RESULTS . . . . .	63
6	SPURIOUS DECODE COUNT AS A FUNCTION OF REPLY CODE (NO DEFRUITER) . . . . .	82

LIST OF APPENDIXES

Appendix

- A TEST EQUIPMENT SET-UP AND CALIBRATION
- B TACAN BEACON REPLY EFFICIENCY RESULTS
- C TACAN BEACON LOADING TEST RESULTS
- D TACAN/DME INTERROGATOR TEST RESULTS
- E DIGITAL DATA BROADCAST TEST RESULTS
- F IFF TRANSPONDER TEST RESULTS
- G IFF INTERROGATOR TEST RESULTS
- H IFF INTERROGATOR VIDEO PHOTOGRAPHS (UNDER SEPARATE COVER)
- I CHARACTERISTICS OF JTIDS WAVEFORMS 2A, 2B, 3A AND 3B (UNDER SEPARATE COVER)

SECTION 1  
INTRODUCTION

BACKGROUND

ECAC was tasked by the FAA to conduct a test at the National Aviation Facilities Experimental Center (NAFEC) to examine the compatibility of the Joint Tactical Information Distribution System (JTIDS) waveforms with equipment operating in the 962 to 1215 MHz Radionavigation band. Previous tests, sponsored by DoD, were held at the Boeing Aircraft Company in Seattle, Washington, in mid-1974, and at the Hughes Aircraft Company in Anaheim, California, early in 1975. During the Hughes tests, many possible JTIDS candidate waveforms were tested using a signal format simulator, and the results were provided to DoD for selection of the JTIDS waveforms. The signal simulator used is not a JTIDS system simulator. It generates waveforms that approximate single-net operation. Based on the test data and other considerations (e.g., anti-jam, JTIDS receiver design, etc.) the JTIDS 3A waveform was selected by DoD.

The proposed NAFEC test differed from the Hughes test in that consideration was to be given to both additional equipment samples and to new one-of-a-kind equipments which were not then operational.

Shortly before the NAFEC test started in April 1975, the number of candidate JTIDS waveforms to be tested was increased by DoD from one to two with the addition of the 3B waveform. When the NAFEC test was well underway, the number of JTIDS candidate waveforms was further increased to four, with the addition of the 2A and 2B waveforms. The 2A and 2B waveforms are a variation of the 3A and 3B waveforms, respectively. JTIDS is still under development. The reader is cautioned that this report is concerned only with the four waveforms tested, and described in detail in APPENDIX I.

OBJECTIVES

The objectives of this project were:

1. To perform compatibility testing at NAFEC involving the JTIDS signal format simulator and equipment operating in the 960 to 1215 MHz Radionavigation band.
2. To document the test results.

APPROACH

A test plan was prepared which indicated what equipment was to be tested and each data point that was to be taken. Most equipments tested were nonmilitary. Two military systems, the AN/APX-72 IFF transponder and the AN/ARN-21C TACAN interrogator, were included because, if affected by JTIDS, they could possibly degrade two FAA systems (the Air Traffic Control Radio Beacon System and the Semi Automated Flight Inspection System (SAFI), respectively). Prior to the start of the testing, this document was distributed to all Government Advisory Group (GAG) members for comments and additions. All comments and additions were incorporated into the final test plan, which was used as a guide throughout the test. The actual equipment testing, data recording and data processing were performed by ECAC personnel. Calibration and maintenance of test equipment and equipment under test were the responsibilities of the equipment lender. The following organizations provided equipment:

1. FAA Headquarters
2. NAFEC
3. Naval Electronics Systems Test and Evaluation Detachment (NESTED)
4. U.S. Army Electronics Command - Fort Monmouth
5. Naval Air Development Center (NADC)
6. Hughes/Boeing

## SECTION 2

## SYSTEM DESCRIPTIONS

TACAN/DME SYSTEM DESCRIPTION

TACAN is a system that provides an aircraft pilot with slant range and bearing to a selected ground beacon. In the air-to-ground mode (A/G), the aircraft determines its distance to a beacon by interrogating it and timing the reply. Bearing is derived by analog techniques. DME operation is similar to TACAN, except that bearing is not provided. That is, the DME interrogator does not extract bearing information from a beacon signal and the DME beacon does not transmit bearing information.

Two modes of operation are available for TACAN/DME A/G use: these are the X mode and the Y mode. In the X mode, the entire TACAN spectrum (962 to 1213 MHz) is utilized; in the Y mode, only the 1025 to 1150 MHz band is used.

The channel pairings for the X and the Y mode TACAN/DME are shown in Figure 1. In the X mode, the beacon transmits in either the 962 to 1024 MHz band or in the 1151 to 1213 MHz band, and the aircraft transmits in the 1025 to 1150 MHz band. If the aircraft is on channel 1X, it is transmitting on 1025 MHz and receiving on 962 MHz. The corresponding beacon is also on channel 1X when transmitting on 962 MHz and receiving on 1025 MHz. If the aircraft is on channel 64X, it is transmitting on 1088 MHz and receiving on 1151 MHz. The corresponding beacon on channel 64X transmits on 1151 MHz and receives on 1088 MHz. In the Y mode, both the aircraft and the beacon transmit in the 1025 to 1150 MHz band. If the aircraft is on 1Y, it is transmitting on 1025 MHz and receiving on 1088 MHz. The corresponding beacon on 1Y transmits on 1088 MHz and receives on 1025 MHz. If the aircraft is on channel 64, it transmits on 1088 MHz and receives on 1025 MHz. Its corresponding beacon is on channel 64Y, transmitting on 1025 MHz and receiving on 1088 MHz.

To obtain range, an aircraft interrogates the beacon with two Gaussian-shaped pulses, each 3.5  $\mu$ s wide, spaced either 12  $\mu$ s (X mode) or 36  $\mu$ s (Y mode) apart. The beacon processes the interrogation and transmits a corresponding reply, two Gaussian-shaped pulses each 3.5  $\mu$ s wide, spaced either 12  $\mu$ s (X mode) or 30  $\mu$ s (Y mode) apart. The aircraft receiver detects the reply and subtracts the beacon delay time from the round-trip propagation time to compute its range from the beacon.

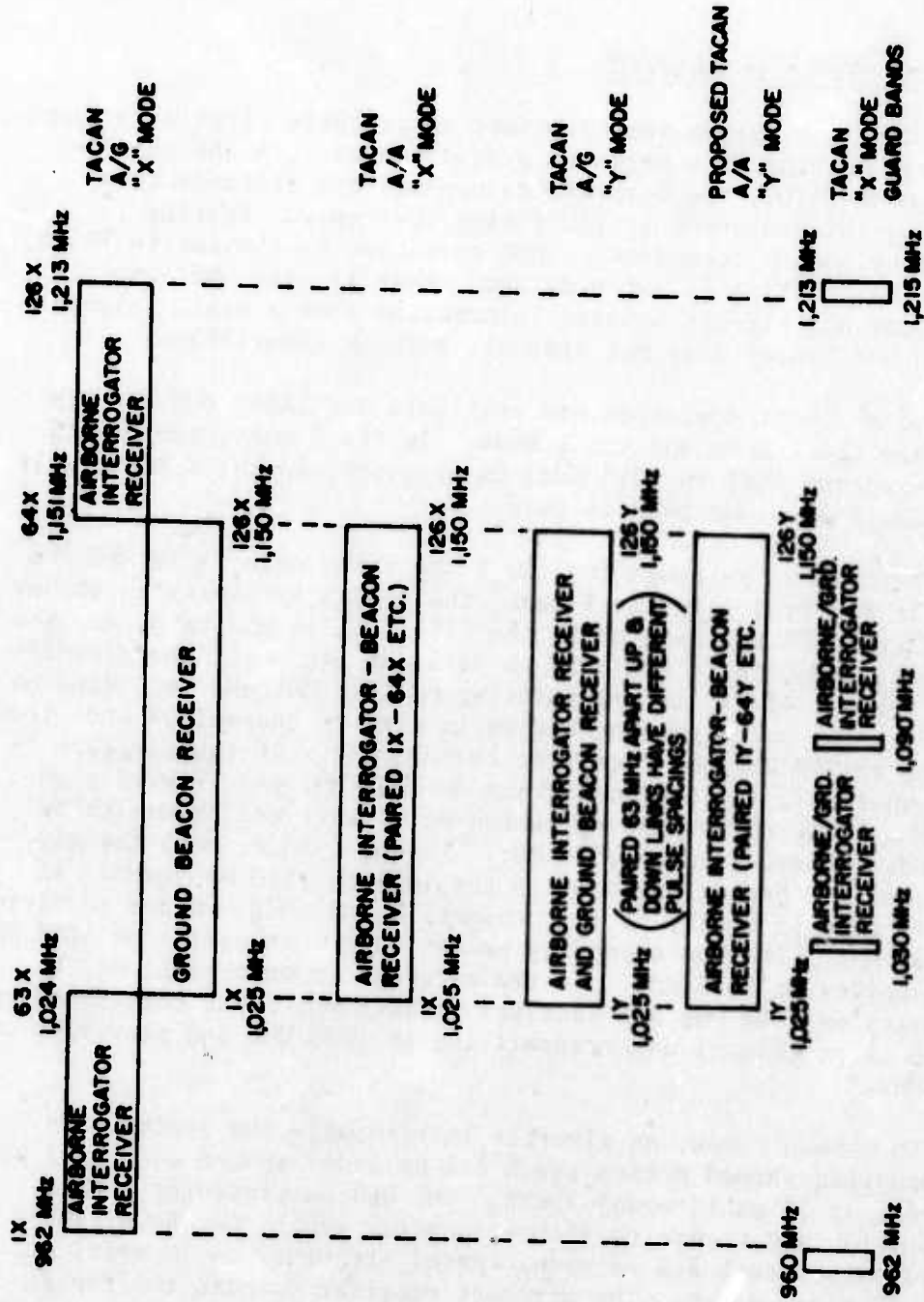

Figure 1. TACAN/IFF receiving channel/frequency allocations.

### TACAN Beacon Operation

The majority of beacons operate with a constant duty cycle, transmitting 3600 pulse pairs/second. These 3600 pulse pairs consist of 2700 random pairs plus 900 reference-burst pairs. If the beacon is not receiving any interrogations, receiver noise generates all of the 2700 pulse pairs required. If the TACAN beacon is replying to 1000 interrogation pulse pairs, noise generates an additional 1700 replies.

The operation of a DME beacon differs slightly from the above. If the number of interrogation-generated replies is less than 1000/second, a constant reply rate of 1000/second is maintained. This consists of only interrogation-generated and noise-generated replies (squitter), since no reference bursts are transmitted. When the number of interrogation-generated replies exceeds 1000/second, the number of noise-generated decodes is essentially zero and the total reply rate equals the interrogation-generated rate. Thereafter, the reply rate will increase in accordance with the interrogation rate until the maximum reply count of 2700/second is reached.

### Airborne Distance Determination

Since the beacon replies to many aircraft interrogations (up to a specified limit), special processing is required in the airborne receiver to detect the reply corresponding to its interrogation. One aspect of the special processing is to insure that no two aircraft transmit interrogations at a synchronous rate. This is accomplished by allowing the interrogations to be controlled by a noisy source, such as the 400 Hz line voltage in the aircraft. This introduces a slight jitter in the PRF of the interrogations. To detect the desired replies from among all replies received, the airborne receiver uses one of three techniques.

The first is the strobe technique in which a small range window moves in time, scanning all possible range delays. If enough replies are detected in the window, its movement will be stopped. If a few of the next replies coincide with the window, the system will "lock up" and will track the desired signal. Some examples of equipment using this technique are the AN/ARN-21C, the RCA AVQ-70 and the NARCO UDI-4. The amount of time required for lock-on is generally less than 30 seconds.

The second technique is achieved using digital circuits. That is, a digital circuit examines reply pulses occurring

immediately after an interrogation. Initially, the window moves to the time delay corresponding to the first pulse received after the transmission of an interrogation. If a second pulse occurs at the same time delay after the next interrogation a confirm mode is established. If the second pulse does not occur, the window will move to the time delay of the next reply that is received. The only replies that are examined are those occurring at a time delay greater than the previously examined delay.

Once the confirm mode is established, the window must detect a few more synchronous replies to "lock on" and to stay in lock. Due to the fact that the digital processor examines the next pulse arriving rather than the next delay, lock-on time is generally a few milliseconds. An example of a DME that employs digital techniques is the KING KDM 7000.

The third and final technique is employed by the NARCO 190. It is characterized by the omission of a tracking loop. That is, it uses the same criterion to stay in lock as it does to acquire. This is unlike the first two, in which it is easier to stay in lock once acquisition has occurred than it is to acquire lock. In the NARCO 190, the search technique examines all possible range returns over several interrogations and selects the one that has the greatest correlation. If the amount of correlation is acceptable (about 50 to 60%), the range is displayed without regard to the previous range displayed. Only if the criterion is not met does the set go into a pseudo-memory mode in which it displays the last acceptable range for 10 seconds.

In general, the acquisition speed of the NARCO 190 is similar to the digital DME (less than a second).

#### TACAN Beacon Bearing Determination

Bearing is derived by detecting the amplitude modulation on the pulse train transmitted by the beacon, and comparing it with reference bursts also transmitted by the beacon. The modulation is achieved by a specially designed cardioid antenna pattern.

The TACAN beacon transmits a reference burst each time the cardioid pattern points east. The aircraft receiver detects the modulation envelope and generates a gate pulse every time the waveform crosses zero in a negative sense. This gate is phase-shifted until it lines up with the reference burst. The number of degrees in the phase shift specifies the bearing.

To obtain accurate bearing, two modulation envelopes are used, a 15-Hz envelope and a 135-Hz envelope. The 15-Hz envelope is used to determine the aircraft bearing within 40°. The 135-Hz envelope is then detected and used to refine the bearing (within the 40° cell) to an accuracy of less than 3°.

#### IFF/SSR SYSTEM DESCRIPTION

Secondary Surveillance Radar (SSR) provides a means of air traffic surveillance as well as military identification (IFF) in Europe and the United States.

Figure 2 shows the general configuration of IFF/SSR equipments. The coder/decoder prepares the interrogations (i.e., target identity requests) and sends them to the interrogator. The interrogations are pulse-amplitude modulated on a 1030 MHz carrier. Aircraft, properly equipped, will detect the interrogations, decode them, and transmit a reply at 1090 MHz. Replies received at the interrogator are decoded and displayed on a Plan Position Indicator (PPI) for the controller.

Four interrogation modes (1, 2, 3/A, C) can provide position and identity information of properly equipped military and civilian aircraft. The modes may operate in conjunction with the primary radar. The IFF/SSR equipment PRF is a submultiple of the radar PRF. When IFF/SSR equipments are used without a primary radar, an internal trigger establishes the PRF. The modes are transmitted automatically in a given repetitive sequence (mode interlace) at the IFF/SSR PRF. Modes 1, 2, and 3/A are normally used by the military for identification and air traffic control. The civil air traffic control systems use mode 3/A for identification and surveillance. Both military and civilian systems may use mode C for altitude reporting.

#### IFF/SSR Interrogation Modes

These modes have the form shown in Figure 3. The  $P_1$  and  $P_3$  pulses represent the interrogation. The  $P_2$  pulse is the Interrogator Sidelobe Suppression (ISLS) pulse. The time spacing between  $P_1$  and  $P_3$  uniquely identifies the interrogation mode. The tables in Figure 3 give the pulse spacing and amplitude requirements for valid mode 1, 2, 3/A, and C interrogations and the specifications for the interrogation pulses.<sup>1</sup>

<sup>1</sup>Selection Order: U.S. National Aviation Standard for the MARK X (SIF) Air Traffic Control Radar Beacon System (ATCRBS) Characteristics, Department of Transportation, FAA 1010.51A, March 1971.

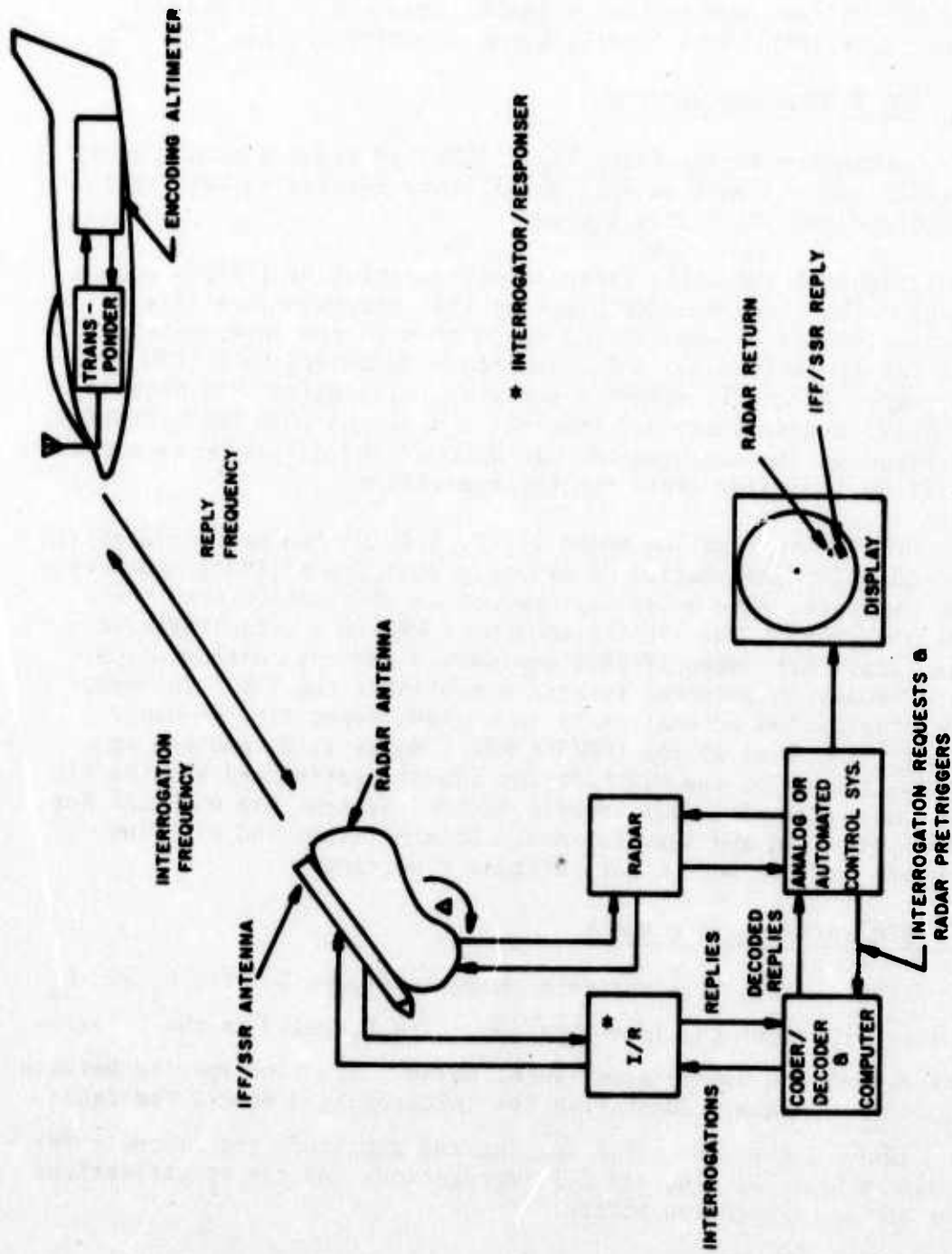
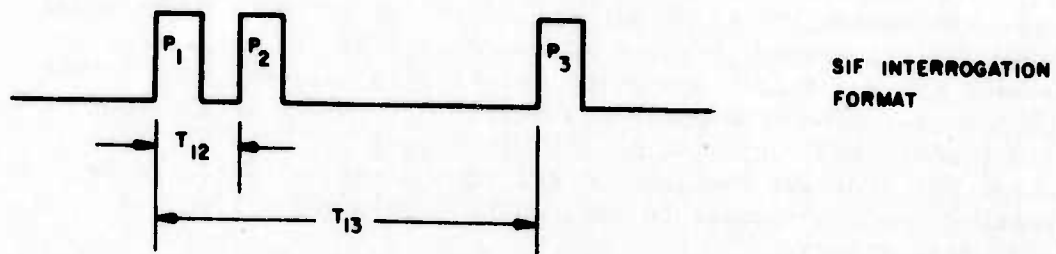

Figure 2. General configuration of IFF/SSR equipments.



PULSE SPACING CRITERIA FOR SIF MODES 1, 2, 3/A, C		
MODE	$T_{13}$ ( $\mu$ s)	$T_{12}$ ( $\mu$ s)
1	$3 \pm 0.1$	$2 \pm 0.15$ ↓
2	$5 \pm 0.2$	
3/A	$8 \pm 0.2$	
C	$21 \pm 0.2$	

PULSE SPECIFICATIONS	
WIDTH	$0.8 \pm 0.1 \mu$ s
RISE TIME	0.05 TO $0.1 \mu$ s
FALL TIME	0.05 TO $0.2 \mu$ s

PULSE AMPLITUDE CRITERIA FOR VALID INTERROGATION
1) $P_1 > P_2 + 9\text{dB}$
2) $P_3 = P_1 \pm 1\text{dB}$

PULSE AMPLITUDE CRITERIA FOR SIDELobe INTERROGATION
$P_2 \geq P_1$

Figure 3. IFF/SSR interrogation characteristics.

The airborne transponder, depending on its function, may have the capability to decode all, some, or any one of the modes. When the transponder detects an interrogation, it prepares a proper reply. Within any mode, all replies have the same format (Figure 4). The code-pulse content is determined by the four-digit octal code selected by the pilot (e.g., Figure 5). The pilot can indicate emergencies and communications failures by setting the transponder to reply with mode 3 codes 7700 and 7600 respectively.

The decoders interfacing with the interrogator identify the signal as a reply by the spacing of the framing pulses, the code pulse content, and the mode of interrogation. The pilot can further validate his identity by transmitting with his replies another pulse (Special Identification Pulse, identified as SPI in Figure 4) spaced  $24.65 \pm 0.05 \mu\text{s}$  after  $F_1$ . This pulse causes the reply on the PPI to be brighter than the response from any other aircraft with the same code.

Mode C requests altitude information from properly equipped transponders and altimeters. The altimeter encodes the aircraft altitude in binary coded decimal (BCD) format. When the transponder decodes a mode C interrogation, the altitude is encoded in the basic IFF/SSR reply format. Mode C is always interlaced with at least one of the other IFF/SSR modes.

#### Defruiter/Decoder Operation

A defruiter is a device that compares each reply received with the previous reply received (delayed by the spacing between interrogations) to determine if the reply codes in both agree. If a pulse position in one does not agree with the pulse position in the other, the extraneous pulse is eliminated. It is pointed out that the defruiter only eliminates pulses that make up the reply, it does not eliminate the reply. The reply is eliminated only if it has no positions which agree with the previous return. This is generally what happens to extraneous replies (fruit). The defruiter can be switched in or out of operation, being used when needed.

A decoder is a logic device that examines the code content of replies. It will produce an output pulse if and only if every pulse in the reply satisfies the code that has been set into the decoder. If an additional pulse is present or if one is missing, the reply is rejected. The decoder operates on the video signal out of the interrogator and normally follows the defruiter if one is employed.

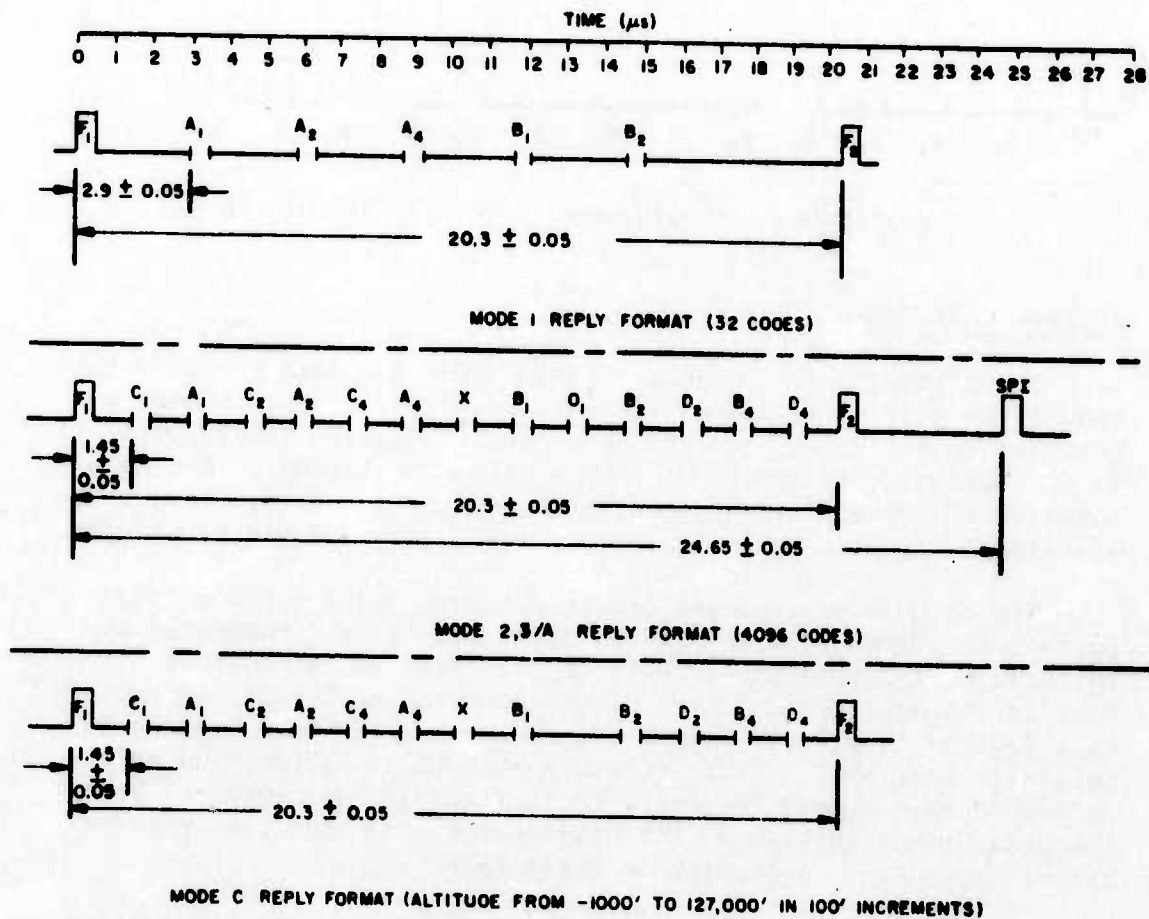

REPLY PULSE SPECIFICATIONS	
WIDTH	0.45 ± 0.10 μs
RISE TIME	0.05 TO 0.10 μs
FALL TIME	0.05 TO 0.20 μs

NOTE: "X" PULSE POSITION NOT NORMALLY FILLED.

Figure 4. IFF/SSR reply characteristics.

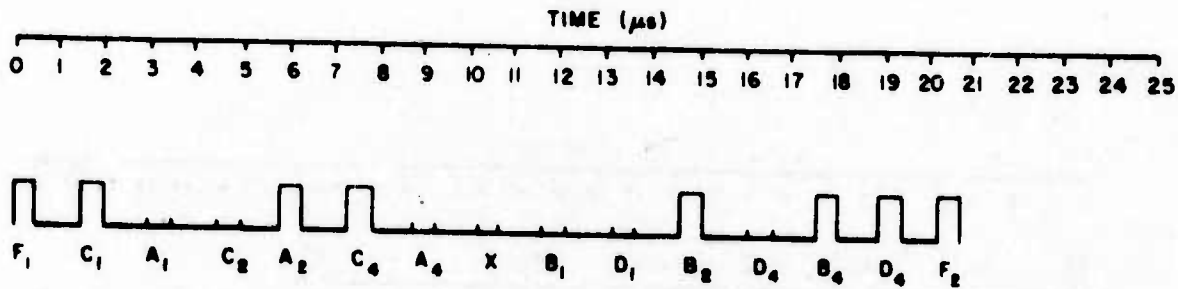

Figure 5. Reply mode 2 or 3/A for code 2654.

DIGITAL DATA BROADCAST SYSTEM

The Digital Data Broadcast System (DDB) has been proposed to reduce the pilot workload while the aircraft is flying through a terminal control area. In the DDB, area navigation (RNAV) Data is automatically transmitted by each TACAN/DME beacon. This data consists of beacon latitude-longitude, beacon identification, site elevation, magnetic variation, type of facility and way-point data.

The data is multiplexed onto the beacon pulse train through pulse-position modulation. After each pulse pair transmitted by the beacon, two data pulses ("A" and "B") can be transmitted. This is illustrated in Figure 6. A pulse in position A corresponds to a logical 0, a pulse in position B corresponds to a logical 1, pulses in both positions signify a word sync character, and no pulses in either position indicate that no data is present. Using the pulse-position method, the maximum bit rate that can be transmitted equals the beacon maximum reply rate.

Data is transmitted using words of fixed bit lengths (either 24 or 30 bits in length). To minimize errors, redundant transmission is employed in which each word is transmitted twice in succession. The system is asynchronous in the sense that the beginning and end of any data word is not referenced to any synchronous signal generated within the beacon. Consequently, in order to indicate the presence of words, word-sync doublets are employed at the beginning of each new word, at the end of the word (which is the beginning of the redundant word transmission) and finally at the end of the redundant word. In order to minimize errors, three word-sync doublets are employed rather than just one. The basic word-sync scheme is illustrated in Figure 7.

When a message is being received in the airborne DDB equipment, a number of conditions must be satisfied before the data can be declared correct. First, a word does not begin to get

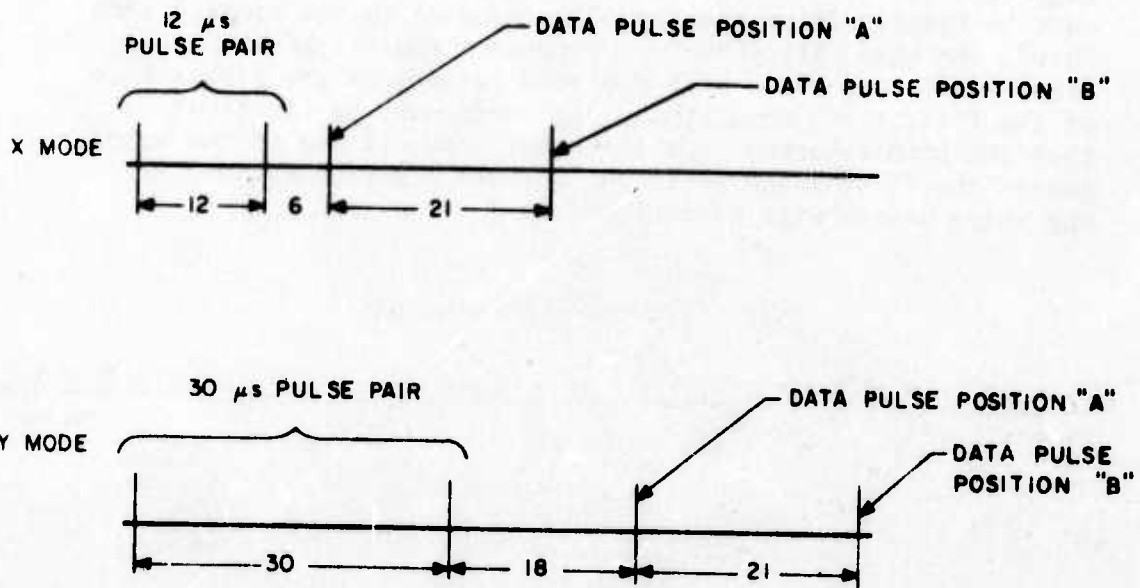

<u>Code Structure:</u>	<u>Data Pulse Position</u>	<u>Code</u>
	"A"	Binary 0
	"B"	Binary 1
	Both "A" and "B"	Word Synch
	Neither "A" and "B"	No Data

Note: All time intervals shown in microseconds.

Figure 6. X and Y mode data coding for DDB.

decoded until at least two successive word-sync characters are received (out of the possible three). Second, the number of data bits received before the next word-sync characters arrive must be exactly 24 or exactly 30, depending on the address code. Third, the word parity must be correct. Fourth, if both the first and second words of a two-word redundancy group pass each of the first three conditions, the words must be identical or they are both rejected. On the other hand, if one of the words passes the first three tests but the other word does not, the one which passes will be accepted as a valid word.

Typical Data Sequence

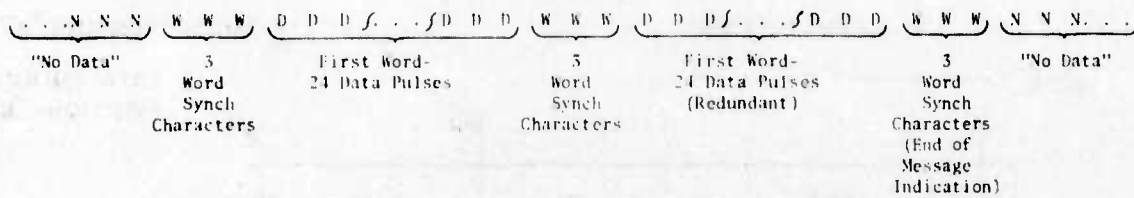

Legend: N = "No Data" Condition  
 W = Word Synch Doublets added to TACAN/DME pulse pairs  
 D = Data Pulses added to TACAN/DME pulse pairs

Note: Each letter shown (N, W or D) corresponds to the data status of each TACAN/DME pulse pair.

Figure 7. Overall data structure for two successive 24-bit words.

JTIDS SYSTEM DESCRIPTION

The JTIDS will provide a high-capacity data-transfer capability (required by tactical aircraft and command and control centers) in a common time-division-multiplexed data network. This operation permits one JTIDS user to transmit while all other users are listening. This enables each user to have access to all of the information transmitted by any JTIDS user within line of sight (LOS). Beyond-LOS coverage is achieved through the use of a relay. The JTIDS system, which is secure and jam resistant, is being designed to operate in the 962 to 1215 MHz radionavigation band.

Figure 8 illustrates the basic time-slot structure of a JTIDS network. The top bar shows a period of 12.8 minutes; this is the epoch on the communications network during which all time slots must

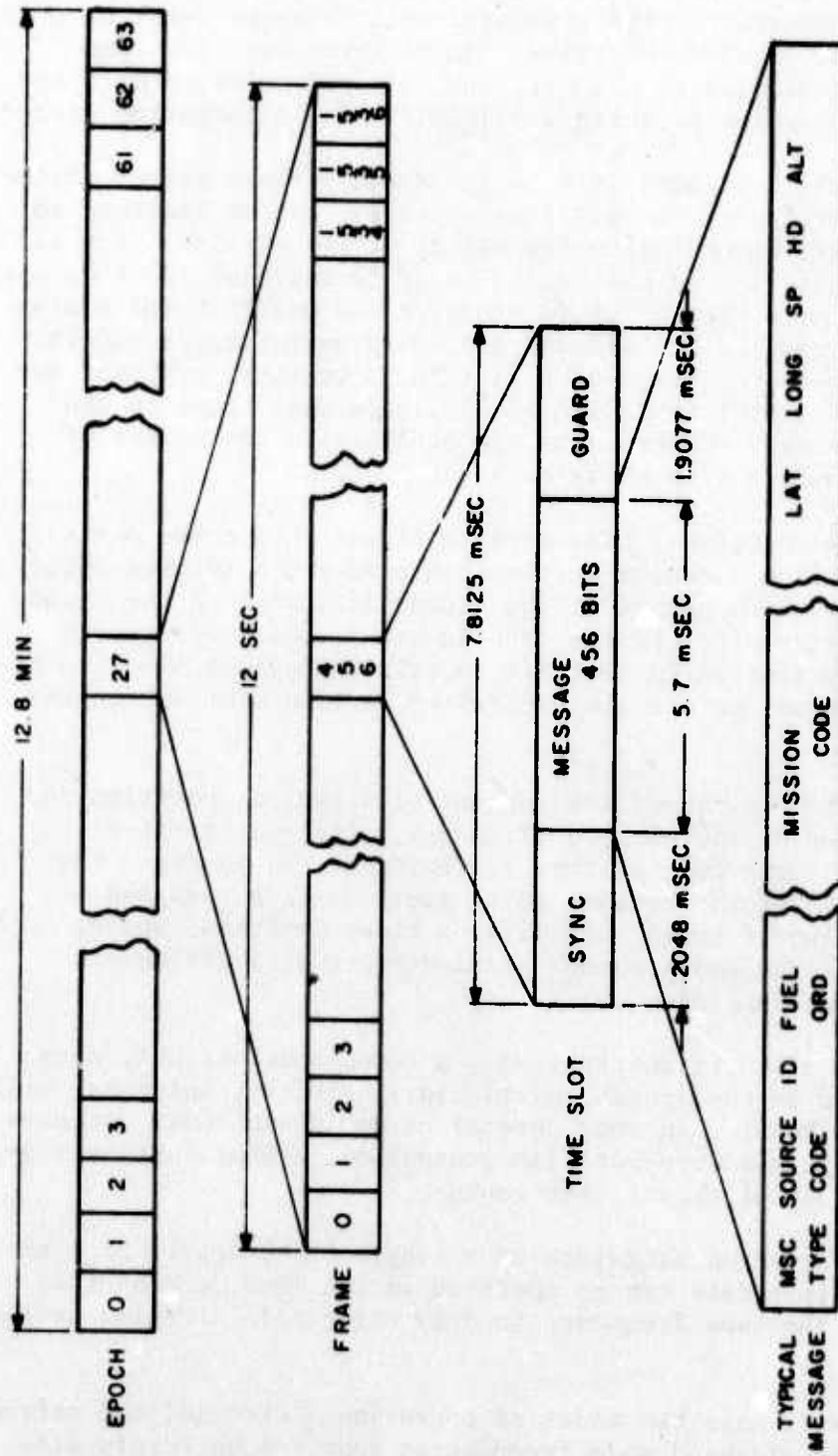

Figure 8. JTIDS time slot structure.

occur. Thus, if a single time slot number is allocated to a particular subscriber, this time slot will recur at least once each 12.8 minutes. No subscriber can be given less than one slot per 12.8 minutes in the net, and this parameter establishes a boundary on system capacity availability for information entry.

The epoch is divided into 64 12-second periods called "frames". As many of the frame time slots as necessary can be assigned to any subscriber, depending on the nature of his mission. For example, it is envisioned that AWACS would be assigned 128 time slots within a frame, within which to report track position and status information from its primary and secondary surveillance radars. During the en-route phases of a mission, a tactical aircraft may be assigned one slot to report his position and status to the other net members. Other units can be assigned the number of slots commensurate with their data entry needs.

Next, an individual time slot is broken into three parts: a synchronization burst, a section containing transmitted information, and a guard period at the close, during which the transmitter is turned off. In the example shown, the guard period lets the transmission in slot 456 radiate throughout the line-of-sight environment before the subscriber in time slot 457 begins transmitting.

The bottom bar shows the content of a typical position and status message on the planned JTIDS net. It consists of a message label, the code of the originator of the message, the identification of the element being reported, its fuel and ordnance status if known, its mission code, position, speed, heading, altitude and a number of discrete indicators such as emergency, bailout, etc.

Because JTIDS is intrinsically a communications net, most antennas used in the system, particularly aircraft antennas, will be omnidirectional. In some special cases, directional antennas can be used to get more anti-jam protection, and/or further reduce the probability of signal intercept.

The information bandwidth of a single JTIDS net is 57.6 kHz. Several multiple nets can be operated in the same geographical area and in the same frequency band by using code division techniques.

JTIDS will have two modes of operation: wideband and narrowband. In the wideband mode frequencies that are uniformly distributed throughout the TACAN band (less the IFF guard bands) are pseudorandomly selected for transmission. In the narrowband mode only one frequency is utilized, and that frequency is 969.5 MHz.

At present, four waveforms are being considered for Time Division Multiple Access (TDMA) operation. They are designated 3A, 3B, 2A and 2B. For additional information on the waveform structure see APPENDIXES A and I.

Figures 9 through 15 are spectrum photos that were taken during the NAFEC testing of the four TDMA waveforms. Figure 9 illustrates the basic narrowband spectrum and Figure 10 illustrates the effect of a narrowband mode filter that may be employed. Figure 11 illustrates the wideband mode of operation. The guard bands provided around the IFF frequencies of 1030 MHz and 1090 MHz are evident. Figure 12 shows a detailed view of the low edge of the band and Figure 13 the high edge of the band. Figure 14 shows a detailed view of the 1030 MHz guard band and Figure 15 the 1090 MHz guard band. The reason for the difference between the guard bands around 1030 MHz and 1090 MHz is that a notched filter was used around 1030 MHz while none was present around 1090 MHz.

The power output of the JTIDS transmitter has not been determined. In order to illustrate distance separations it was necessary to assume that JTIDS was transmitting 1 kW effective radiated power (ERP) (includes antenna gain if any). The actual power transmitted can be taken into account by shifting the calculated curves by an amount equal to the difference between the actual power and the assumed power of +60 dBm. That is, if 100 watts is used (+50 dBm) a 10-dB shift is required.

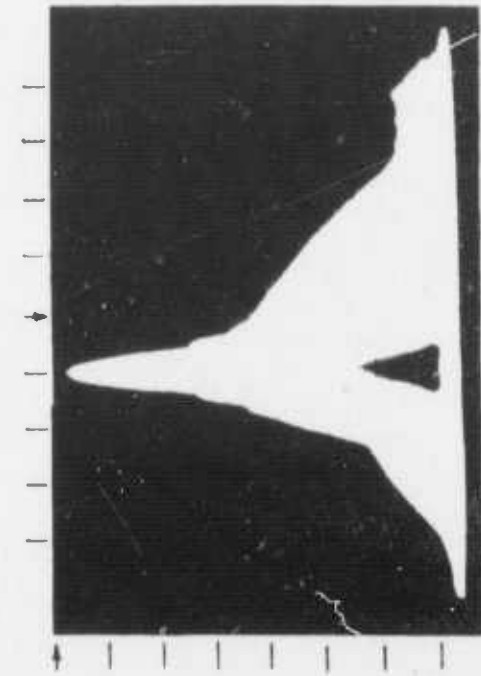

TDMA 3B Narrow Band without Filter

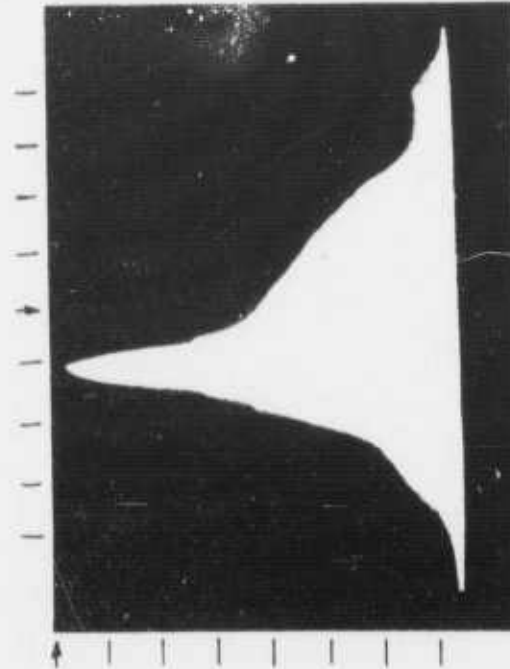

TDMA 2B Narrow Band without Filter

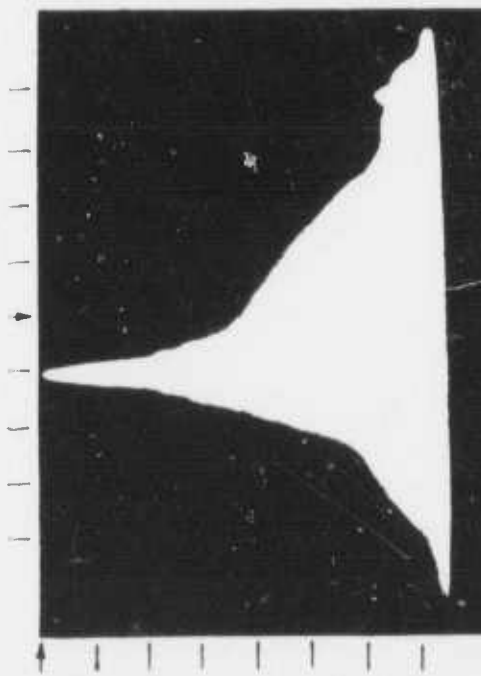

TDMA 3A Narrow Band without Filter

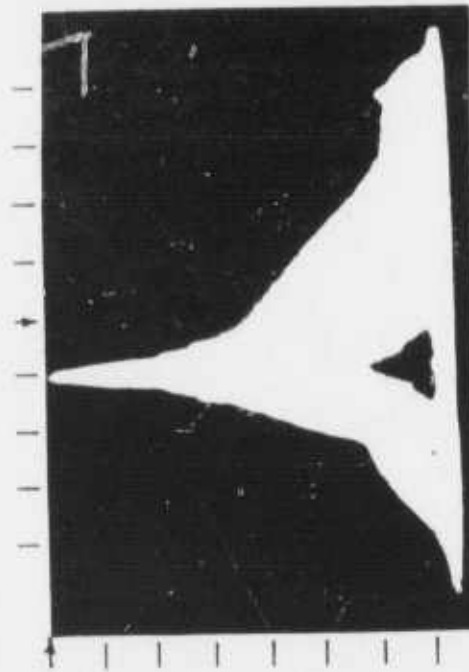

TDMA 2A Narrow Band without Filter

Figure 9. TDMA spectrums, 980 MHz center, 10 MHz/div, 10 dB/div, 0 dBm ref.

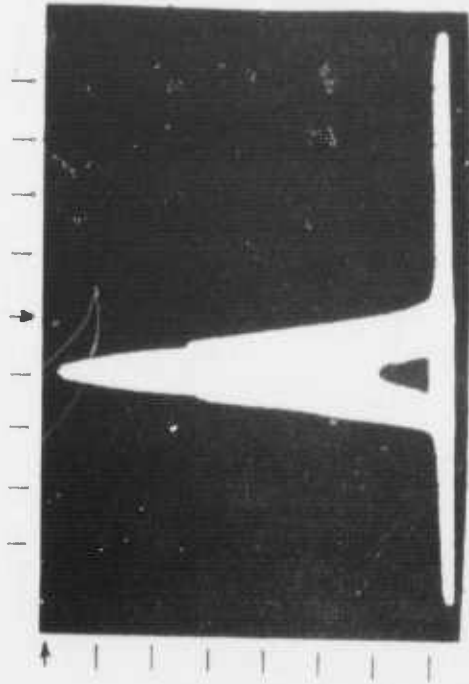

TDMA 3B Narrow Band with Filter

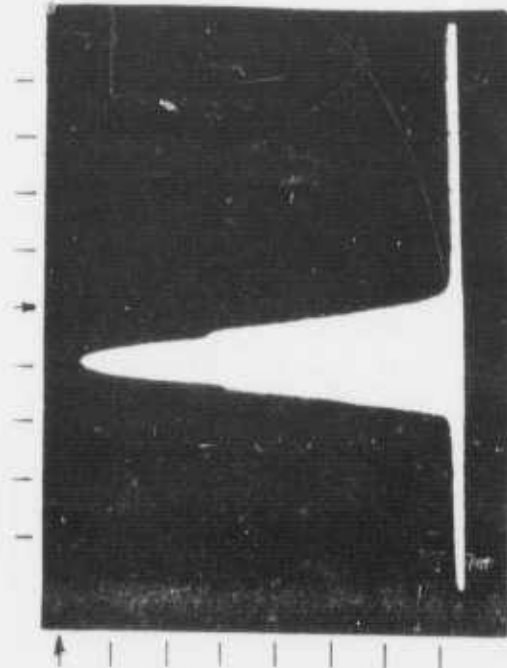

TDMA 2B Narrow Band with Filter

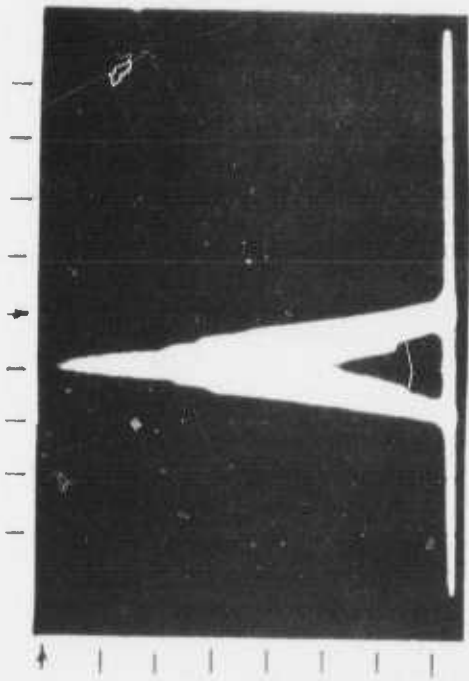

TDMA 3A Narrow Band with Filter

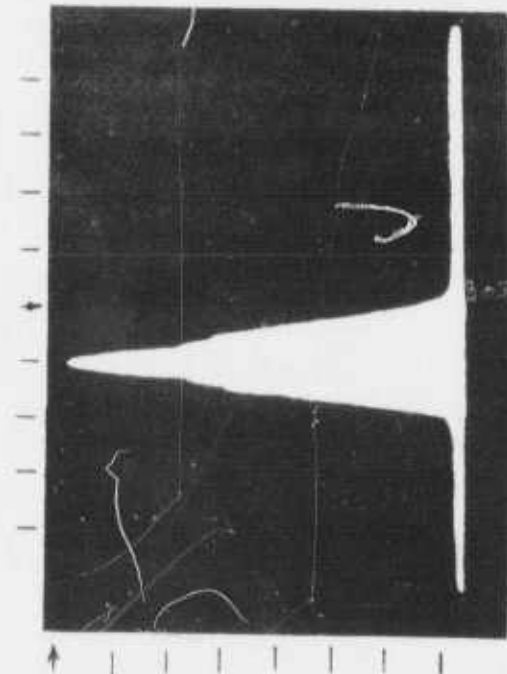

TDMA 2A Narrow Band with Filter

Figure 10. TDMA spectrums, 980 MHz center, 10 MHz/div, 10 dB/div, 0 dBm ref.

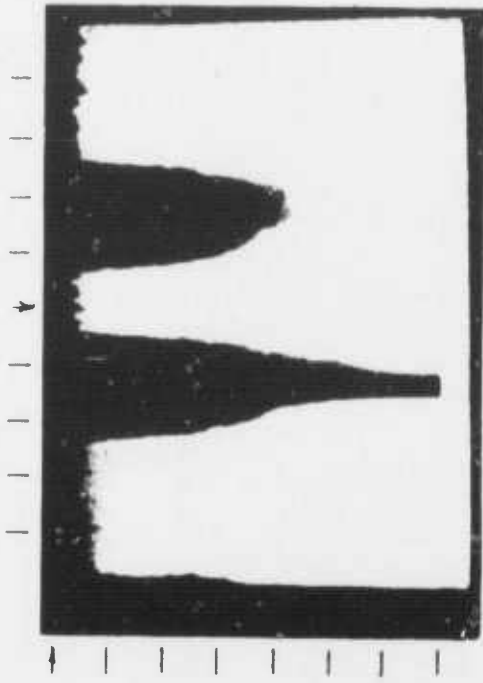

TDMA 3B Wideband

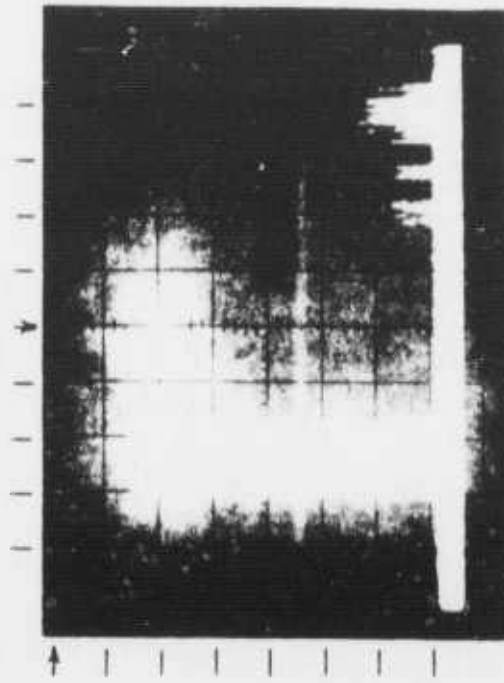

TDMA 3A Wideband Spurious

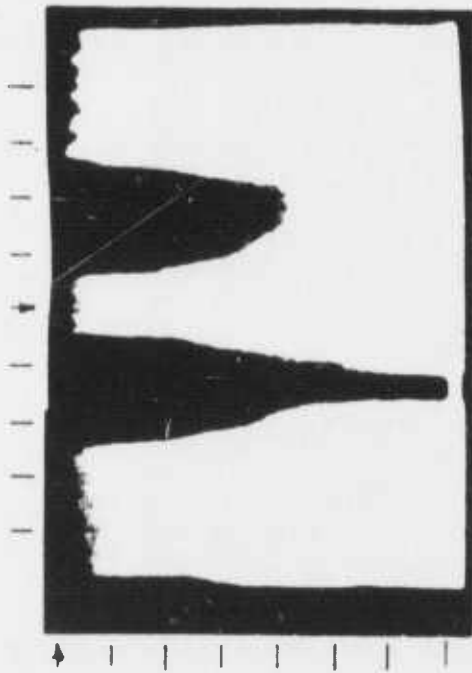

TDMA 3A Wideband

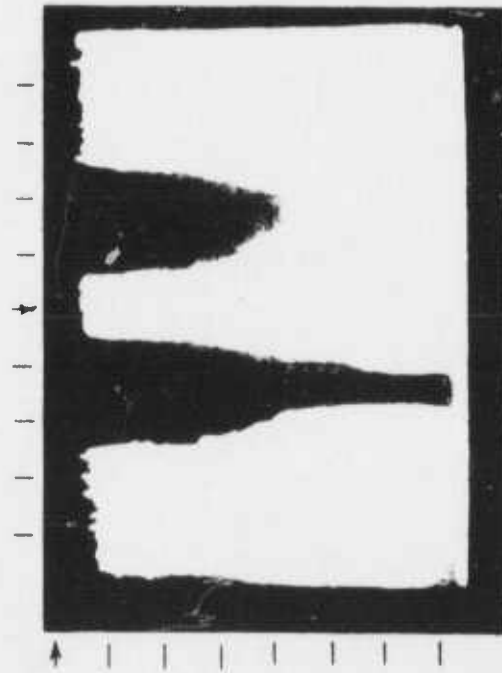

TDMA 2B Wideband

Figure 11. TDMA entire band spectrums: 1060 MHz center, 20 MHz/div, 10 dB/div, 0 dBm ref. spurious spectrum: 1530 MHz center, 200 MHz/div, 10 dB/div, +10 dBm ref.

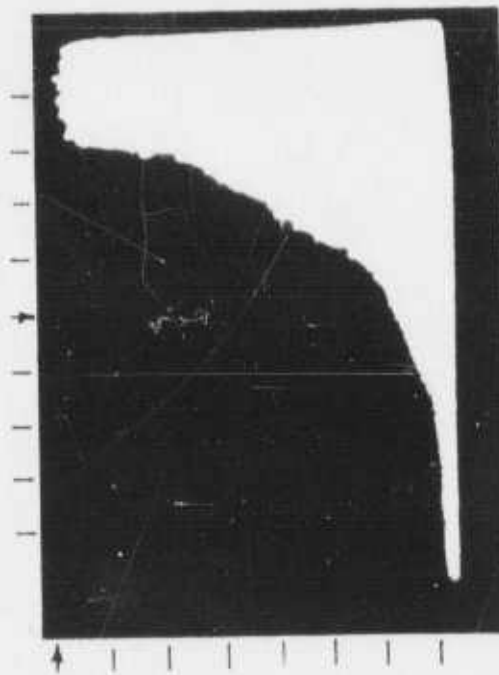
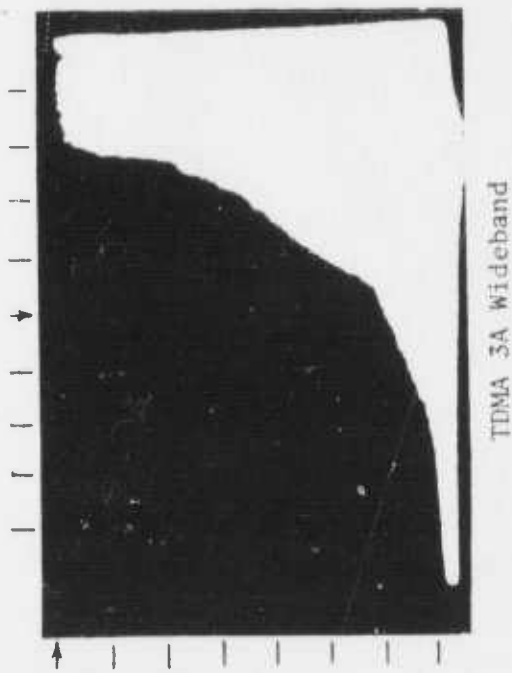
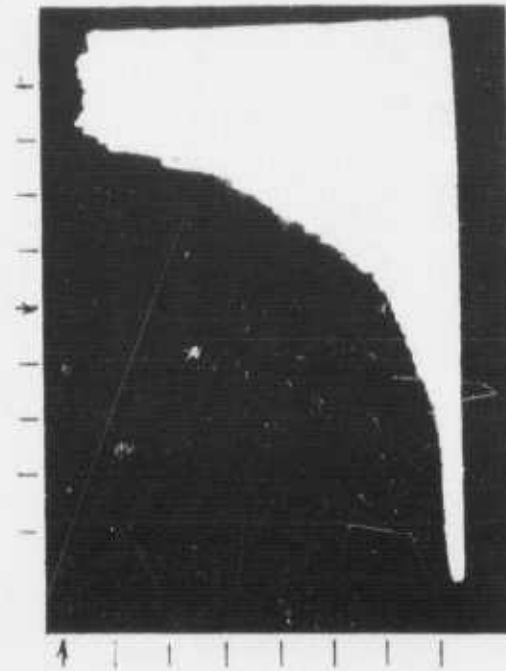
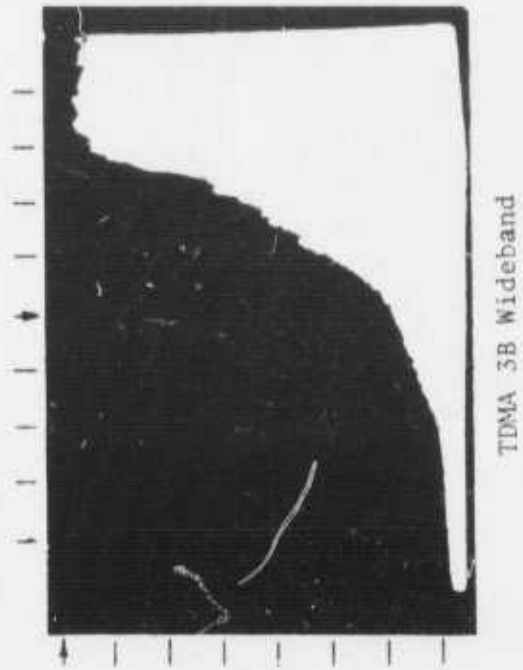

Figure 12. TDMA spectrum of low band edge, 950 MHz center, 5 MHz/div, 10 dB/div, 0 dBm ref.

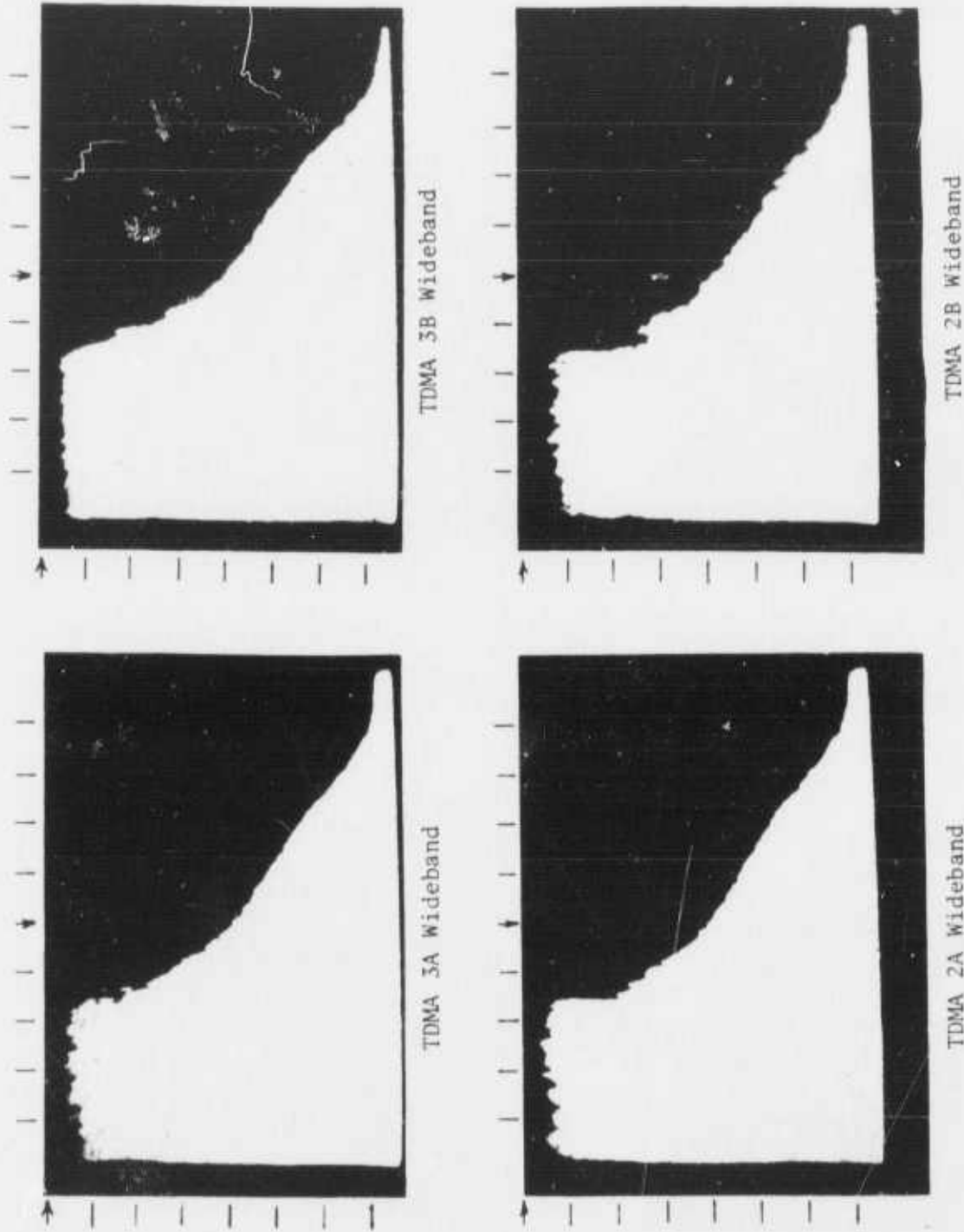
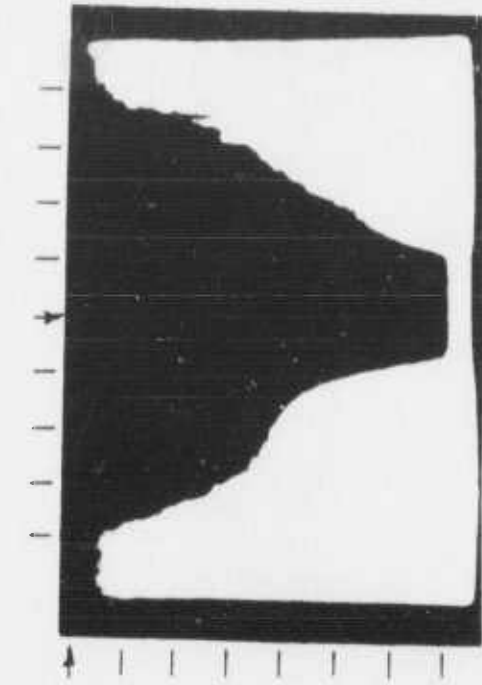
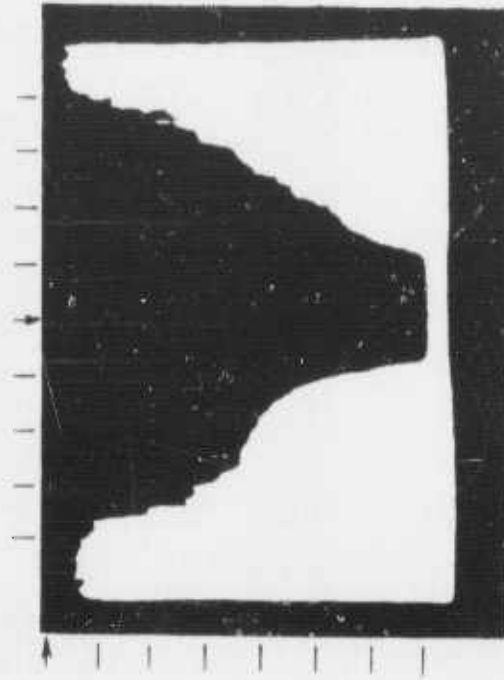

Figure 13. TDMA spectrum of high band edge, 1220 MHz center, 5 MHz/div, 10 dB/div, 0 dBm ref.



TDMA 3B Wideband



TDMA 2B Wideband

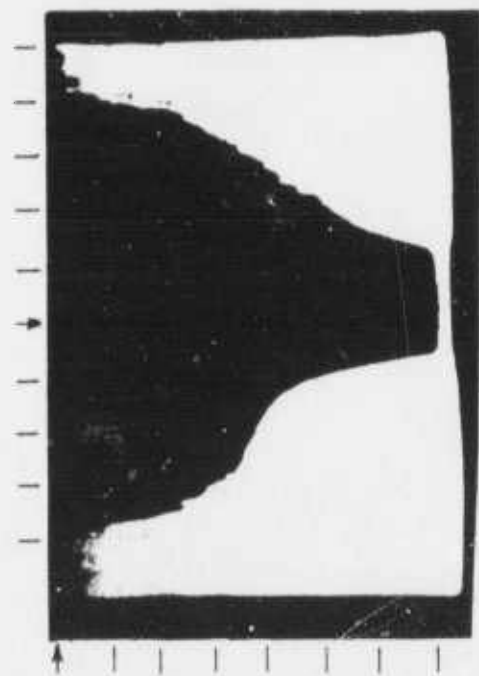

TDMA 3A Wideband

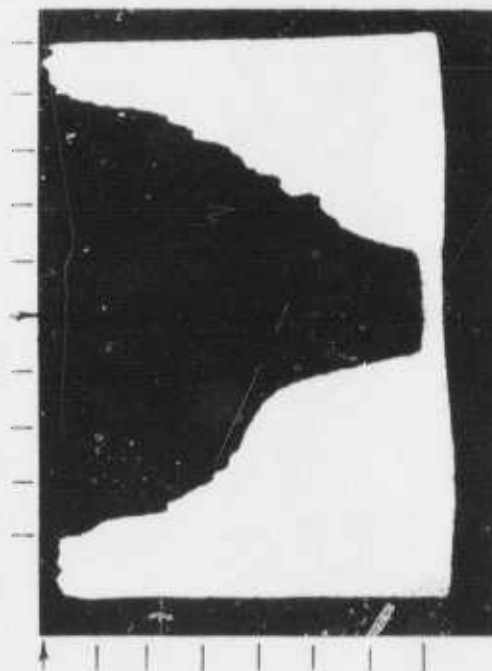

TDMA 2A Wideband

Figure 14. TDMA spectrum of 1030 MHz notch, 1030 MHz center, 5 MHz/div, 10 dB/div, 0 dBm ref.

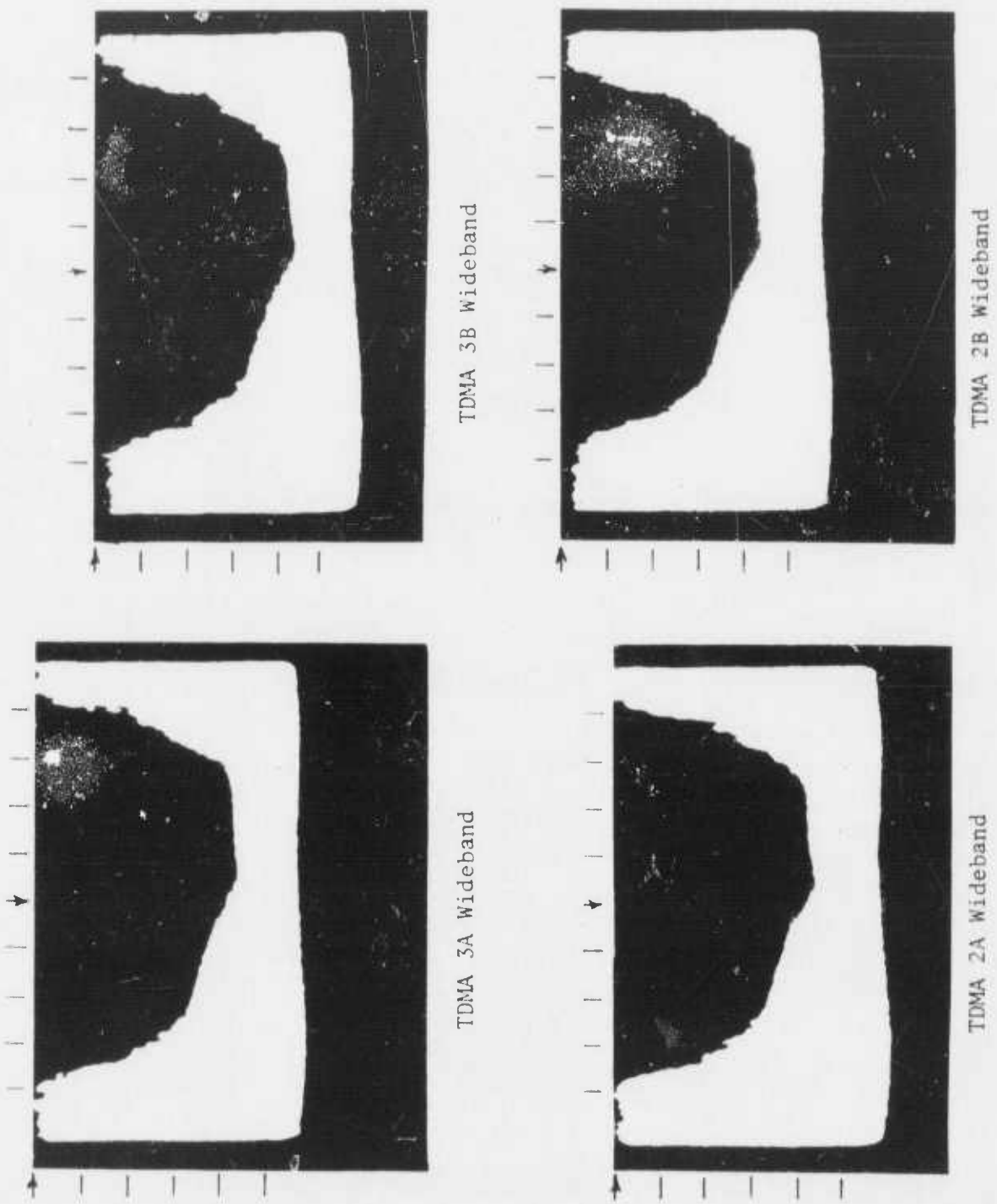

Figure 15. TDMA spectrum of 1090 MHz notch, 1090 MHz center, 5 MHz/div, 10 dB/div, 0 dBm ref.

## SECTION 3

## TEST PROCEDURES

INTRODUCTION

Tests were performed on the 25 receivers listed in TABLE 1 to determine their susceptibility to the JTIDS TDMA signal. This section explains the parameters that were measured, the test setups employed, and the data points taken. Also, the sensitivity measurements that were performed on each receiver are explained and documented.

All calibration and equipment checkout procedures, and pertinent calibration information that was used in the tests, are included in APPENDIX A. The FAA assumed responsibility for the calibration and maintenance of all victim receivers examined in the test with the exception of the NARCO UDI-4 and NARCO 190, which were rented.

TACAN BEACON TEST

The TACAN beacon test investigated the effect of the TDMA signal on beacon reply efficiency and on beacon loading. Reply efficiency and loading are parameters that directly affect the performance of an airborne DME obtaining range from a beacon. If beacon-reply efficiency is reduced, the airborne DME will receive fewer replies in response to its interrogations. Depending on the amount of reply reduction and the particular design of the airborne DME, range acquisition may require a longer-than-normal time interval or may not be achievable at all. If the TDMA signal is decoded, the beacon receiver will become loaded. Loading essentially reduces the ability of the beacon to service the number of aircraft it was designed to service. The net effect of TDMA loading is that some aircraft could be completely denied service.

Sample Size

Five beacons were tested. These were an RTB-2 (X mode), a AN/GRN-9C (X mode), a modified RTB-2 (X mode), a modified RTB-2 (Y mode) and a Butler DME 1020. The RTB-2 is a TACAN beacon that comprises 54% of the beacons deployed in CONUS. The AN/GRN-9C, also a TACAN beacon, comprises 35%.

The modified RTB-2 is in the developmental stage. Basically, the modification incorporates greater receiver dynamic range, leading-edge detection, variable echo suppression (activated after

TABLE 1  
EQUIPMENT TESTED AT NAFEC

1. TACAN Beacons
a. RTB-2 X Mode
b. Modified RTB-2 X Mode
c. Modified RTB-2 Y Mode
d. AN/GRN-9C X Mode
e. Butler DME 1020 X Mode
2. TACAN DME Interrogators
a. King KDM 7000 (X and Y Mode) (2 equipments)
b. Collins 860E2 (X and Y Mode)
c. King 705 (X and Y Mode)
d. RCA AVQ-70 X Mode
e. NARCO UDI-4 X Mode
f. NARCO 190 (X and Y Mode)
g. AN/ARN-21C X Mode
3. IFF Interrogators
a. ARTCBI-4
b. ARTCBI-3
4. IFF Transponders
a. AN/APX-72
b. Genave 4096
c. Regency 505I
d. Collins 621A-6
5. Digital Data Broadcast

the decoder), increased aircraft handling capacity (higher reply rate) and both X and Y mode operation. The X and Y modes of operation were both considered in the test.

The Butler DME 1020 beacon is a DME only (no azimuth function). It transmits approximately 100 watts (compared with the normal TACAN beacon power level of 10 kW) and is intended for terminal area use only. At present, only a few of the DME-only beacons have been deployed in CONUS, but FAA anticipates the deployment of more.

#### Beacon Set-up

The following beacon setup was performed prior to each test.

1. The beacon was operated with the high voltage on. A closed system test employing a dummy load was used to preclude accidental radiation of the TDMA signal.
2. The beacon identification signal was turned off to minimize disruption of reply counts.
3. The receiver test and/or receiver sensitivity switch was turned on to permit use of a variable desired PRF.
4. On the Butler DME, which was remotely monitored, it was necessary to activate the monitor bypass switch and to place the normal/bypass switch in the bypass position.

#### TDMA Waveform Generator Setup

The normal JTIDS frequency assignment scheme would protect the IFF frequencies of 1030 MHz and 1090 MHz. The set frequencies of the available RTB-2 and Butler beacons were such that they would also be protected by the normal assignment scheme. Therefore, the normal scheme was modified to inhibit a different set of JTIDS frequencies: 961-964 MHz, 1025-1035 MHz, and 1143-1216 MHz. This combination of frequencies provided a uniform JTIDS frequency density around all TACAN beacon frequencies encountered in the test. The normal assignment scheme, which inhibits the same number of possible JTIDS frequencies, is described in APPENDIX A.

#### Reply Efficiency Test

For the reply efficiency test, the beacon's built-in signal generator was used to generate the desired interrogations and the beacon monitor was also used to provide the detected replies. The TDMA signal was fed into the beacon receiver under test through a directional coupler in the beacon's RF patch panel. In all cases,

the coupler used was the one connected to the power detector. The power detector was disconnected for the duration of the test; however, this did not affect the beacon's performance. All of the beacons tested except the Butler provided a 20-dB directional coupler. The Butler had a 30-dB directional coupler.

The beacon test setup is shown in Figure 16. Reply efficiency is determined by dividing the synchronous reply count by the desired interrogation rate. This was accomplished by means of two different techniques. On the AN/GRN-9 and the Modified RTN-2 X Mode beacon, reply efficiency was obtained using two separate counters and manually dividing the resulting readings (a 10 second average was taken). On the RTN-2 X mode, Modified RTN-2 Y Mode, and the Butler DME beacon, reply efficiency was obtained directly from a SYSTRON DONNOR 6153 counter which automatically computed the ratio of the total reply count to the interrogation count.

On the Butler DME, the two counts required for the reply efficiency calculation were not externally available and it was necessary to open the cabinet to make the connections. The reply count was obtained from PC card 3A-11, pin 11, and the total interrogation rate was obtained from PC card 3A-6, pin 14. The voltage level for the interrogation rate was not sufficient to fire the counter. In order to count the interrogation rate it was necessary to feed the output of pin 14 into the built-in scope and drive the counters from the gate output jack.

The TDMA RF coupling network is shown in Figure 17. It consists of a TDMA waveform generator, two directional couplers, step attenuators, an isolator, and a spectrum analyzer.

*Sensitivity Measurement.* Beacon receiver sensitivity (MDS) for the purpose of the test was taken to be the level of a signal containing 400 pulse pairs/second that would produce a 70% reply efficiency.

The procedure was as follows: with the step attenuators set at 120 dB which corresponds to no interference and the PRF of the internal signal generator set at 400 pulse pairs/second, the reply efficiency was monitored and the internal signal generator level was varied until a reply efficiency of 70% was obtained.

It was discovered during the test that the Y-mode beacon required a larger-than-normal signal level to achieve a 70% reply efficiency. This was due to the 96- $\mu$ s dead time in the Y mode beacon, as opposed to 72- $\mu$ s dead time employed in X mode beacons.

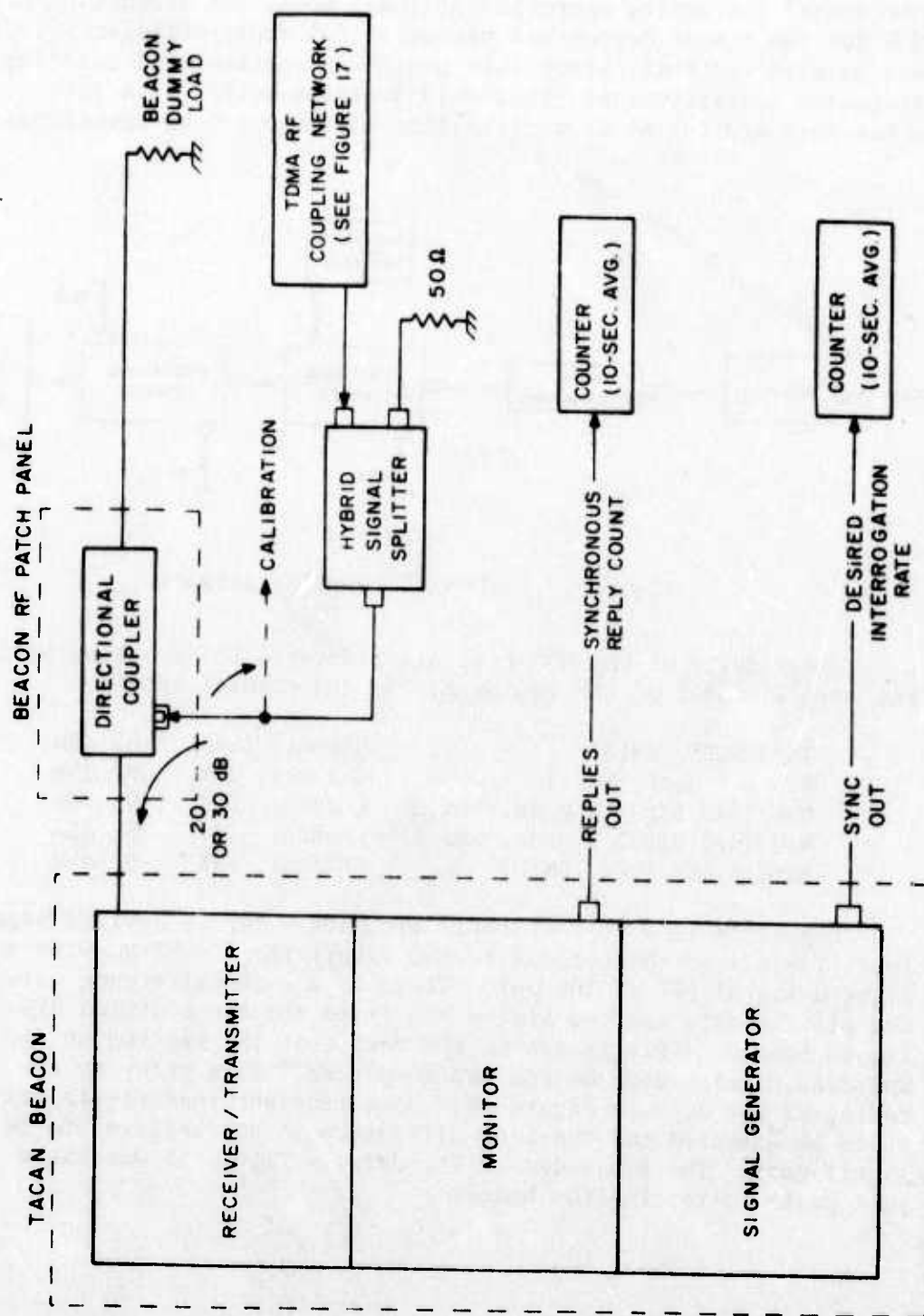

Figure 16. TACAN beacon reply efficiency test.

The dead time is the amount of time the receiver is blanked following the decoding of a pulse pair. In consultation with FAA NAVAIDS personnel<sup>a</sup> concerning operation of the Y mode, the definition of MDS for the Y mode beacon was placed at 65% reply efficiency. It was pointed out that, since this procedure contradicted existing equipment specifications, it should be taken solely as a test bench mark and not as a relaxation of the existing specifications.

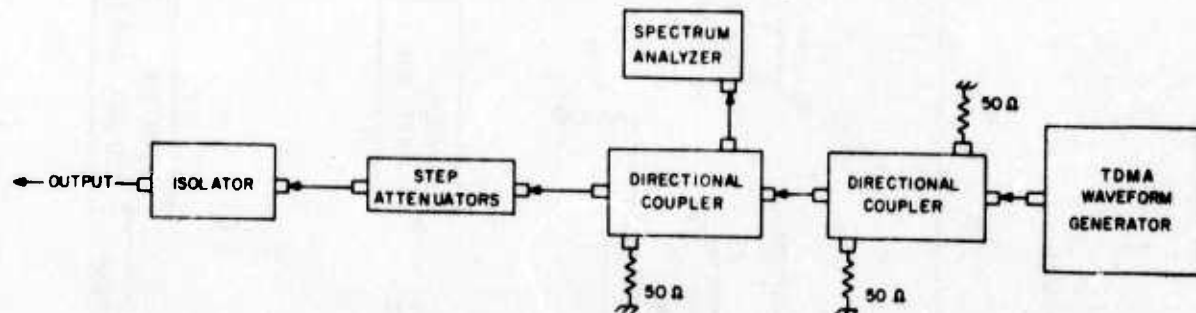

Figure 17. TDMA RF coupling network.

The results of the MDS test are indicated below, along with the serial number of the equipment and the channel tested.

AN/GRN-9C, SN183	Channel 114X	-95 dBm
RTB-2 X Mode, SN5.1	Channel 27X	-92 dBm
Modified RTB-2 X Mode, SN5.2	Channel 27X	-91 dBm
Modified RTB-2 Y Mode, SN5.2	Channel 27Y	-92 dBm
Butler DME 1020, SN503	Channel 28X	-90 dBm

Figure 18 is a plot of reply efficiency versus desired signal level for all of the beacons tested except the AN/GRN-9C with a desired signal PRF of 400 pps. There is a 1-dB difference between the plotted data and the stated MDS level for the modified RTB-2 X-mode beacon. This is due to the fact that the testing on the modified RTB-2 X-mode beacon was completed 7 days prior to the taking of the data in Figure 18. Some receiver sensitivity drift is to be expected and the 1-dB difference is not believed to be significant. The remainder of the data in Figure 18 was taken just prior to testing the beacon.

<sup>a</sup>FAA (ARD 332).

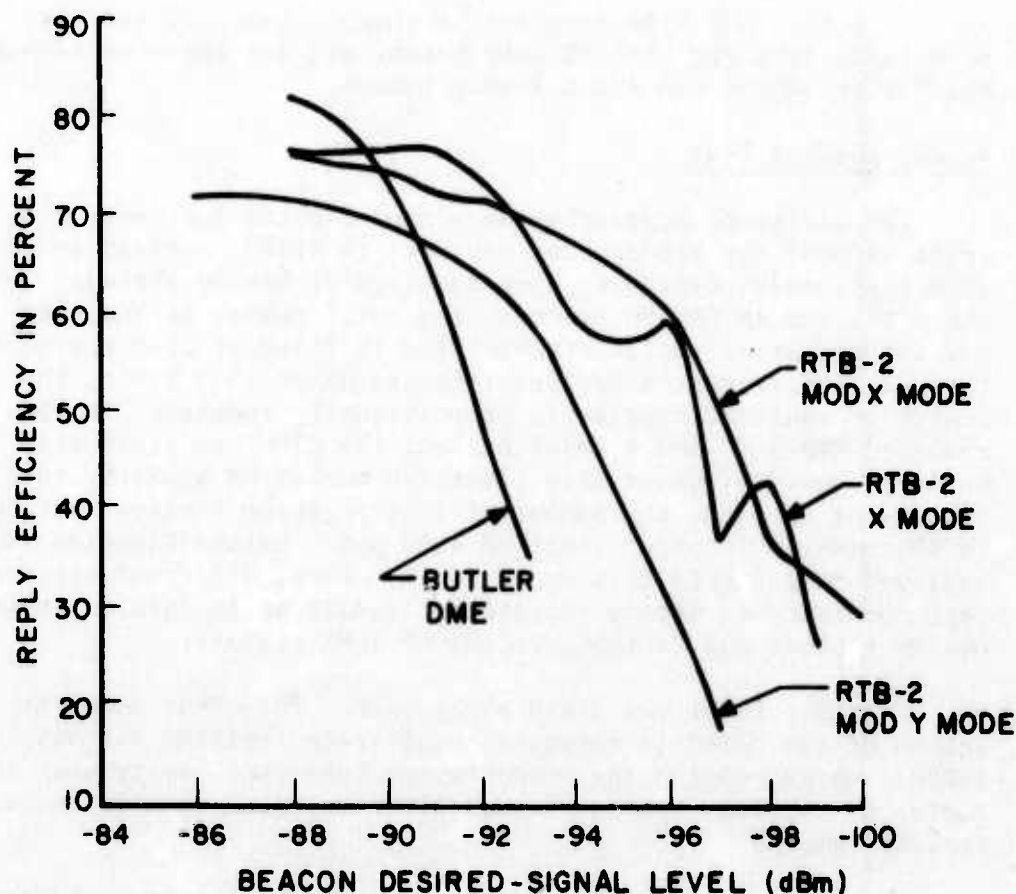

Figure 18. Beacon receiver sensitivity data.

As can be seen from the graphs, the reply efficiency curves flatten out with increasing signal level and drop sharply with decreasing level. Also evident from the curves is the disparity between the Y mode beacon and the X-mode beacons.

*Parameter Variations for Reply Efficiency Test.*

1. Desired signal levels: MDS + 1 dB and MDS + 3 dB.
2. Beacon receiver channel: whatever channel the beacon was tuned to.
3. TDMA mode: wideband mode only.
4. Desired interrogation rates: 1000, 2700 and 3300 pulse pairs/second. These were chosen to represent different aircraft deployments.
5. TDMA power levels (in dBm): -120, -100, -80, -60, -50, -40, -20, and 0. If a 30-dB coupler was used, the 0 dBm level could not be achieved. With the coupler present, the series of points taken were: -120, -110, -90, -70, -60, -50, -30, and -10 dBm.

6. TDMA time slot duty factors: 50%, 25% and 10%. To save time, data for the 10% duty factor was not taken on either the Butler DME or the RTB-2 X-mode beacon.

#### Beacon Loading Test

Two different approaches were used for the beacon-loading tests because the transponder operates in either a fixed or variable reply mode, depending upon the type of beacon tested. In the RTB-2 and AN/GRN-9C beacons, the total number of squitter and interrogation replies transmitted is fixed at 2700 pps such that, as interrogation replies increase up to this limit, the number of squitter replies is proportionally reduced. In the modified RTB-2 (X and Y mode) beacon, the 2700-pps limit also applies; however, above this limit the number of squitter replies remains at zero and the number of interrogation replies continues to increase to an upper limit of 4000 pps. Desensitization is employed to maintain this upper limit. Thus, different strategies were necessary to detect the decodes resulting in invalid transponder replies due to the presence of TDMA signals.

Consider first the fixed-reply case. This test used the action of the beacon's automatic reply-rate limiting circuit (ARRC), which reduces the beacon's receiver sensitivity when the number of decoded replies exceeds 2700/second, with all squitter replies removed.

The fixed-reply test setup is shown in Figure 19. The internal signal generator is used to simulate the percentage of aircraft that have just entered the beacon's service volume and the EPSCO signal generator was used to simulate the loading effect of the remaining aircraft obtaining service. The reply efficiency of the internal signal generator was measured for various PRF's of the EPSCO signal generator. This was done with and without TDMA interference present. As the PRF of the EPSCO signal generator is increased, any significant change in reply efficiency with TDMA interference, compared to the no interference case, will indicate the presence of TDMA decodes. The change is due to the desensitization that occurs when the decoded replies of the EPSCO, the internal generator and any TDMA decodes exceed 2700/second. Since the internal generator level is generally near MDS, it is greatly attenuated when the decoding limit is exceeded. If the TDMA signal does not decode, the reply efficiency results with and without interference will be similar. This is discussed in greater detail in Section 4.

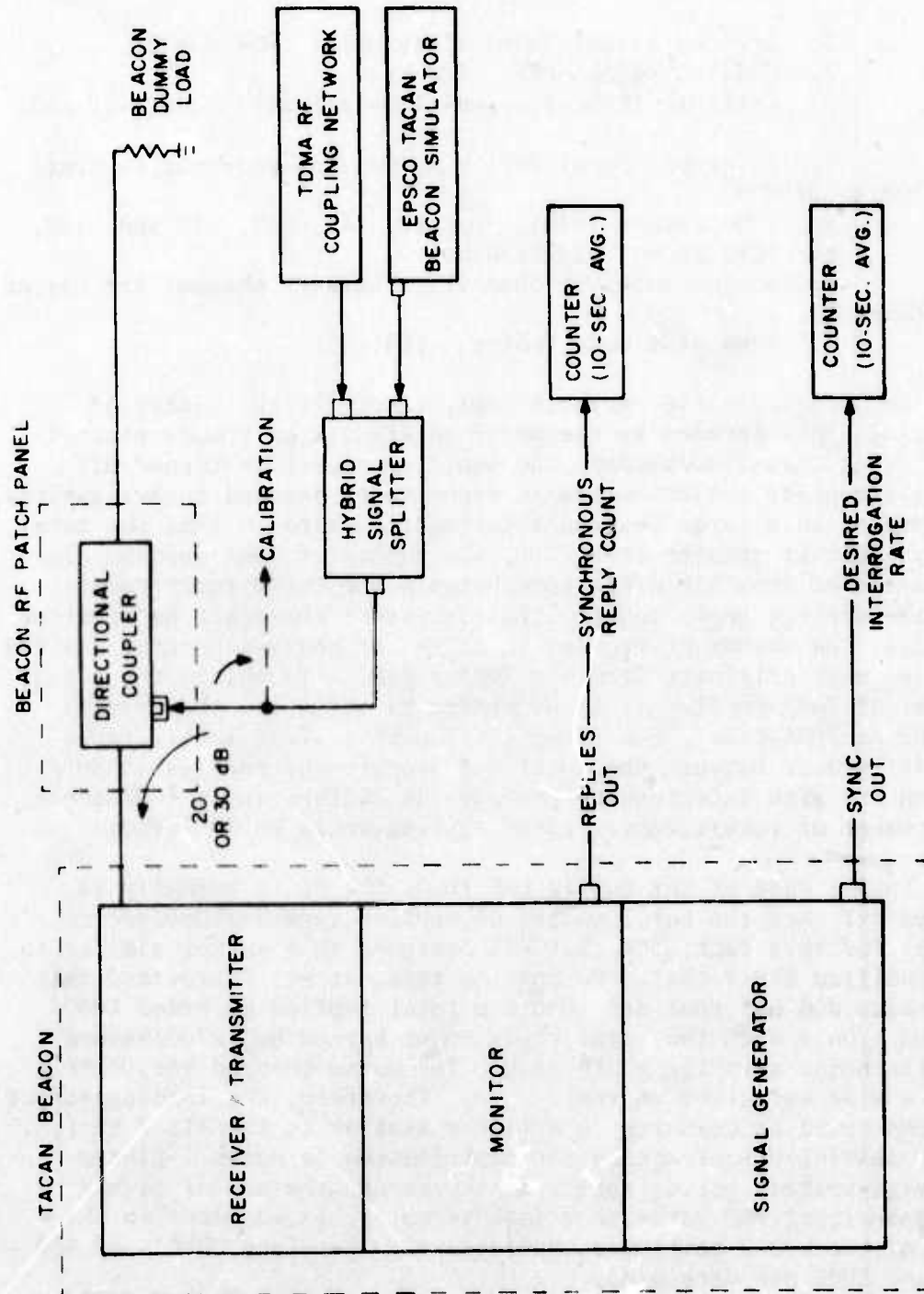

Figure 19. TACAN beacon loading test (fixed reply).

*Beacon-Loading Parameters for Fixed Reply Test.* The variations under which the beacon loading data were taken on the AN/GRN-9C and RTB-2 beacons were as follows:

1. Desired signal level (internal): MDS + 1 dB.
2. Desired signal PRF: 500 pps.
3. External (EPSCO) signal levels (dBm): -60, -70 and -80.
4. External signal PRFs: As many as required in range of 2300 to 3200 pps.
5. TDMA levels (dBm): 0, -20, -40, -60, -80 and -120.
6. TDMA mode: wideband only.
7. Beacon receiver channel: Whatever channel the beacon was tuned to.
8. TDMA slot duty factor: 50%.

Consider next the variable reply case. If the number of interrogations decoded by the modified RTB-2 X or Y mode beacons is greater than 2700/second, the squitter source is turned off and all replies generated are in response to decoded interrogations. By putting in a large desired interrogation rate so that the total reply count is greater than 2700, the number of TDMA decodes can be estimated from the difference between the total reply count and the desired reply count. That is, since there are no squitter decodes, the number of replies in excess of the synchronous desired replies must originate from the TDMA signal. To obtain the actual number of TDMA replies it is necessary to normalize the results to the no-TDMA case. For example, if with no TDMA interference the difference between the total and synchronous replies is 300/second and with interference present the difference is 400/second, the number of interference-caused replies would be 100/second.

In the case of the Butler DME 1020, the noise normally is turned off when the total number of replies exceeds 1000/second. Except for this fact, the test was designed in a manner similar to the modified RTB-2 test. During the test, it was discovered that the noise did not shut off when the total replies exceeded 1000/second. Only when the total reply count approached 2700/second did the noise abruptly go to zero. The noise changed very little over a wide variation in reply rate. Therefore, the loading effect of TDMA could be measured in a manner similar to the RTB-2 test, after initially subtracting the contribution of noise. Since noise-generated replies were always present, the use of high desired-signal PRF rates to eliminate noise, as was done in the case of the RTB-2 test, was unnecessary. Therefore, PRF's of 500 pps and 1000 pps were used.

The variable-reply test setup is shown in Figure 20. Unlike the loading test for the AN/GRN-9C, no external signal generator is required. Even though it is not necessary to calculate reply efficiency, the counter used on the interrogation rate is still required as a check. All counters are set to average over a 10-second interval. On the modified RTB-2 beacon, the total reply count is provided via a test point on the receiver console, and on the Butler beacon it is provided inside the cabinet on PC card 2A8, pin 9.

*Beacon-Loading Parameters for Variable Reply Test.* The variations under which the beacon loading test was performed on the modified RTB-2 X and Y mode beacons and on the Butler DME beacon, are indicated below. (If different data points were taken on the two beacon types it is so indicated):

1. Desired signal level (internal): modified RTB-2 - MDS + 3 dB, spot checked for MDS + 10 dB, Butler DME 1020 - -40 dBm, spot checked for -80 dBm.
2. Desired signal PRF: modified RTB-2 - 3850/second, spot checked for 3400/second, Butler DME 1020 - 500/second, spot checked for 1000/second.
3. TDMA power levels in dBm: Same as for reply efficiency test.
4. TDMA slot duty factor: 50%, spot checked for 25% and 10%.
5. TDMA mode: wideband only.
6. Beacon receiver channel: Whatever channel the beacon was tuned to.

#### DIGITAL DATA BROADCAST

Because of the manner in which the Digital Data Broadcast (DDB) system is implemented, TDMA interference can affect only the airborne DDB receiver. The purpose of the DDB test was to assess the effect of the TDMA signal on the operation of a DDB feasibility model. The DDB model used in the test was intended to prove out the DDB concept and may not resemble the final DDB system design.

The test setup for the DDB system is shown in Figure 21. The desired signal was transmitted over an RF link and detected with a TACAN antenna. It was coupled into the DDB receiver along with the TDMA interference using the hybrid signal splitter. Due to power problems at the transmitting site, a TACAN antenna could not be employed. The signal was transmitted through a DME antenna which prevented the application of the 15-Hz and 135-Hz modulation envelope found in a normal TACAN signal. The resulting DDB signal was that of a DME-only beacon. It is believed

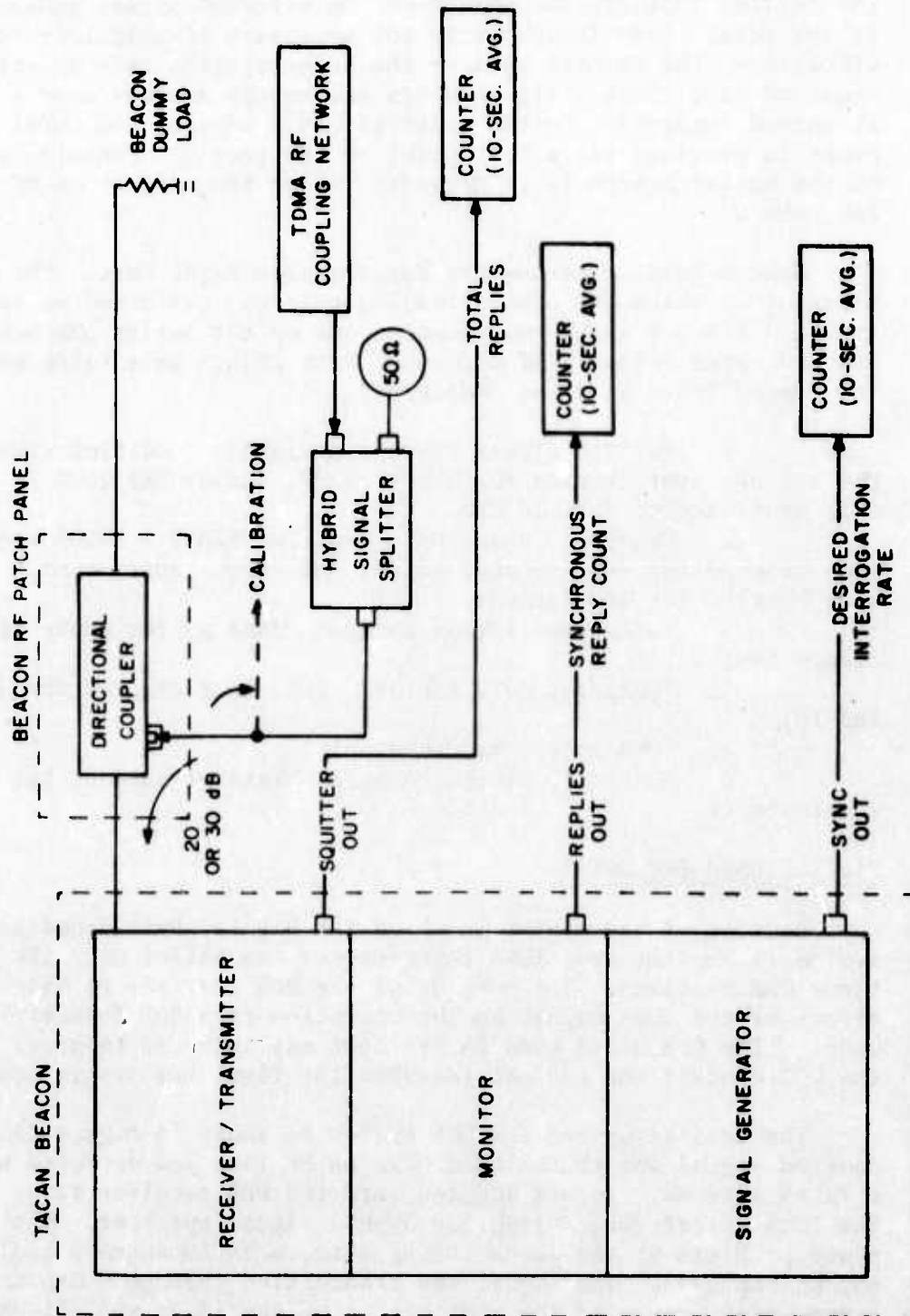

Figure 20. TACAN beacon loading test (variable reply).

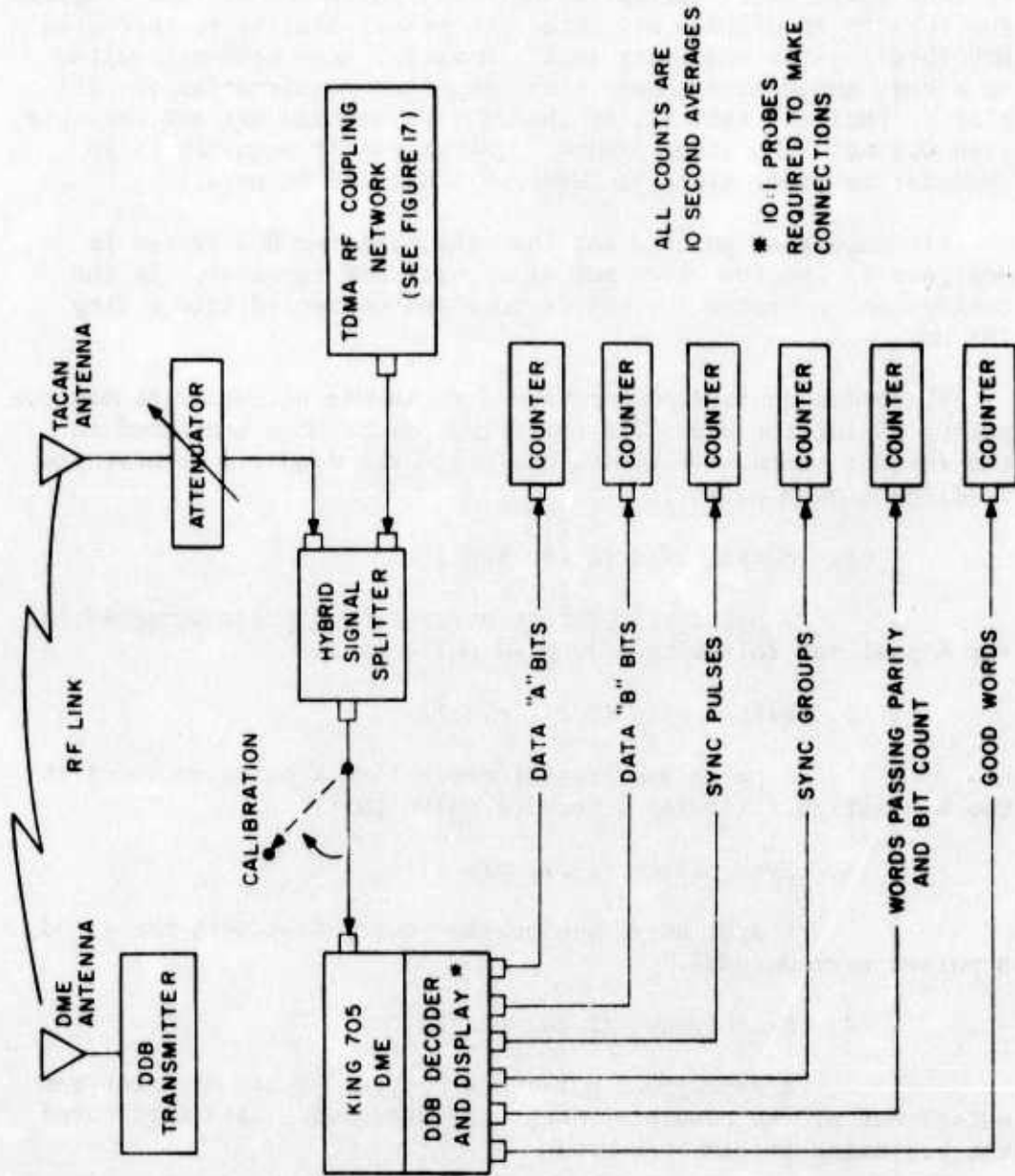

Figure 21. Digital data broadcast test setup.

that the results of the test are nevertheless representative of the effects of DDB transmission on a normal TACAN signal.

The airborne DDB system has a display which indicates the call letters of the TACAN beacon and the RHO, THETA coordinates of RNAV waypoints. Initially, data was taken on the time required for the DDB to display all data in a manner similar to that of a DME interrogator acquiring lock. However, this method resulted in a very subjective answer since the time required for the display to indicate that all of the data was stored was not reliable, even without TDMA interference. (Sometimes it acquired in 30 seconds; at other times it required 5 minutes or more.)

It should be pointed out that the airborne DDB system is designed to use the video out of a basic DME receiver. In the configuration tested the DDB decoder was connected into a King 705 DME.

In order to take comparative data it was necessary to monitor points inside the DDB. The following points were monitored in the decoder board. (A ten-to-one probe was required to minimize loading on each point.)

1. Data A bits (Z 24, pin 1).

A pulse was present every time a pulse occurred in the A position following a decoded pulse pair.

2. Data B bits (Z 29, pin 11).

A pulse was present every time a pulse occurred in the B position following a decoded pulse pair.

3. Sync pulses (Z 21, pin 11).

A sync pulse was present every time both the A and B pulses were decoded.

4. Sync groups (Z 26, pin 2).

A sync-group pulse was present if two adjacent sync pulses out of the possible three were detected. This designated the beginning or end of a word.

5. Words passing parity and bit count (Z 12, pin 6).

A pulse was provided if a word contained exactly 24 or 32 data bits and it also passed the parity check.

## 6. Good words (pin 9).

A pulse was provided if either of the two following conditions were met:

- a. Both redundant words passed parity and bit count and they agreed with one another
- b. Only one of two redundant words passed parity and bit count.

It is believed that the "good words" count is the best indicator of the performance of the DDB system as it is presently configured. The remaining test points are intended to provide insight into the effect of any future changes in the DDB system design.

The test consisted of taking 10-second averages of the above six test points for various TDMA interference conditions. Also, it was decided during the test that some sort of data should be taken on the display. The test procedure was as follows:

1. The specific test condition was set up (TDMA level, TDMA duty factor, desired signal level, etc.)
2. The channel number of the King 705 was momentarily changed and then returned. This erased the display
3. After the channel was returned, all six counters were reset to zero
4. Ten-second average readings were taken from all counters simultaneously
5. After fifteen additional seconds, the display was examined and the condition was recorded using one of the following notes:
  - a. Acquired - if nearly all of the display was complete
  - b. Partial - if some of the display was complete
  - c. None - if no data was displayed
  - d. Error - if station identification was shown incorrectly.

This is the only error indicated since no attempt was made to insure the accuracy of the RNAV points. This decision was arrived at in part to save time and in part due to the design logic in the DDB decoder, which permits errors to be displayed. That is, it is felt that the DDB system is not as free from locking on to erroneous data as the basic DME system is. Since navigation would depend on the RNAV display, design changes should be incorporated to minimize error readouts.

DDB Sensitivity

The sensitivity of the DDB was not specified. In order to determine sensitivity, data was taken on the six test points with the TDMA level set at -120 dBm. This data is shown in Figure 22. The "good word" count is the most revealing indication of system performance as it is presently designed. Based on the point at which the "good word" count declines rapidly, the sensitivity of the DDB receiver was taken to be -68 dBm. This is 9 dB less sensitivity than the -77 dBm sensitivity of the King 705 DME.

*Parameter Variations for DDB Sensitivity Test.*

1. Desired signal levels: MDS + 2 dB, MDS + 4 dB, MDS + 6 dB and MDS + 10 dB.
2. DDB channel - 27X, which was the channel that the DDB beacon was tuned to. (Even though the airborne DDB can be placed in Y mode, this mode could not be tested because the DDB beacon could not transmit in Y mode. It was suggested to FAA personnel<sup>a</sup> that a closed-system test be performed to enable Y mode operation. However, it was decided that the RF link technique should be pursued since it closely resembles operational conditions.)
3. TDMA slot duty factor: 50%, spot checked for 25% and 10%.
4. TDMA power levels in dBm: as many as required.
5. TDMA modes: wideband and simulated narrowband. The narrowband mode interaction had to be simulated since the DDB was on a fixed frequency. This was accomplished by putting the TDMA generator on a single frequency that had the same frequency relationship to channel 27X as the real narrowband mode frequency (969 MHz) had to either channel 18X or 19X. The TDMA simulator was placed on 977 MHz and 978 MHz to simulate channels 18X and 19X, respectively. No narrowband filter was available to filter the TDMA spectrum on the frequencies of 977 and 978 MHz.

In addition to the normal test data, some investigative data was taken to determine how many errors were due to spurious A and B pulse decodes and spurious sync decodes. The test setup was identical to that described except that the DDB information was removed from the signal transmitted by the beacon. The resulting desired signal was that of a normal beacon. Under these conditions all pulse counts initially would be zero without TDMA interference. As the TDMA level was increased, any increase in the pulse counts would be the result of TDMA interference.

---

<sup>a</sup>FAA (ARD 332).

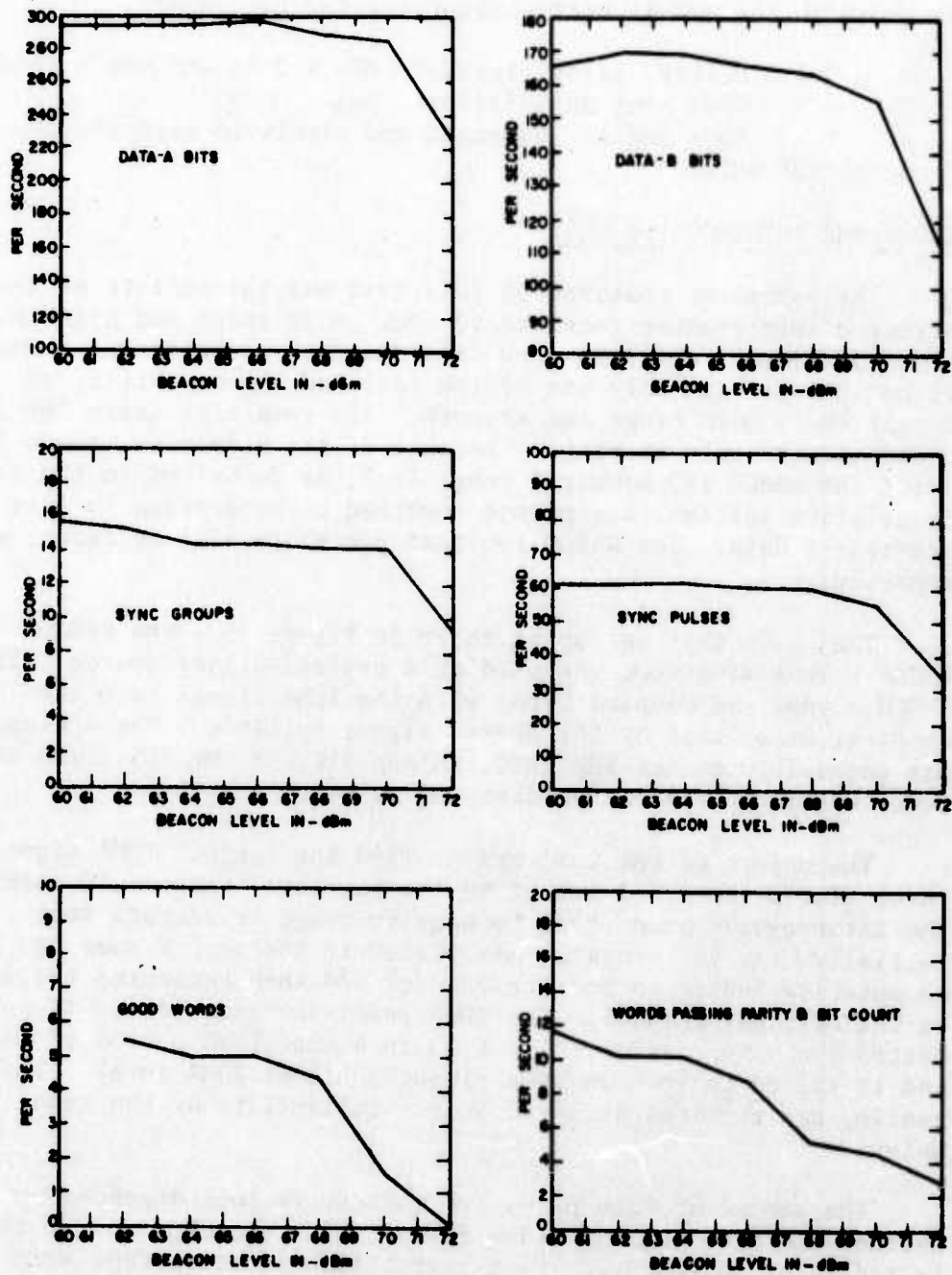

Figure 22. Digital data broadcast receiver sensitivity data.

The data points for the DDB portion of the test were the same as those in the normal test, except for the following:

1. Desired signal levels: MDS + 2 dB and MDS + 10 dB
2. TDMA slot duty factor: 50%
3. TDMA modes: wideband and simulated narrowband (channel 19X only).

#### TACAN/DME INTERROGATOR TEST

The parameter measured in this test was the ability of the airborne interrogator receiver to lock on in range and azimuth. Eight different receivers were tested and the results are summarized in TABLE 2. Only one of the sets had the capability of acquiring in both range and azimuth. The remaining seven DME sets could acquire only in range. Because of the different manner in which the NARCO 190 acquired range lock, as described in the system description section, a separate test had to be devised to take meaningful data. The NARCO 190 test procedure will be described separately.

The basic test set-up is shown in Figure 23. The EPSCO TACAN beacon simulator was used as a desired-signal source. The EPSCO signal was coupled along with the TDMA signal into the receiver under test by the hybrid signal splitter. The AGC voltage was accessible on the KDM-7000, AN/ARN-21C and KDM 705. The AGC level was monitored but no data was taken.

The object of the test was to find the largest TDMA signal level (for a specified set of test conditions) that would permit the interrogator under test to acquire range or azimuth lock. Initially, the interrogator was placed in the search mode by momentarily tuning to another channel and then returning the set to the original channel. The TDMA level was recorded if it permitted the interrogator to lock on in a specified period of time and it failed to lock on at a slightly higher TDMA level. This reading was repeated often to insure reliability of the test point.

The period of time permitted to acquire lock depended on whether the interrogator had a fast or slow search time. This is indicated in TABLE 2. Fast-search-time interrogators were allowed 15 seconds to acquire lock and slow-search-time interrogators were allowed 30 seconds.

Consider next the NARCO 190 test. Each of the interrogators tested except the NARCO 190 possesses a tracking loop. The tracking loop causes the interrogator to be more resistant to interference

TABLE 2  
TACAN/DME INTERROGATOR SENSITIVITY DATA

Nomenclature	Serial Number	Type	Search Time	T.O. <sup>a</sup>	Measured MDS Channel			
					18X	19X	33X	53Y
AN/ARN-21C	16314	Military	Slow	-85	-92	-93	-93	N/A
Narco UDI-4	6500416	General Aviation	Slow	-75	-74	-74	-72	N/A
Collins 860 E-2	1182	Commercial	Slow	-86	-96	-96	-96	-96
King KDM 705	1291	General Aviation	Slow	-80	-77	-77	-77	-79
RCA AVQ-70	1260	Commercial	Slow	-86	-93	-93	-90	N/A
King KDM 7000	1993	Commercial	Fast	-90	-94	-94	-96	-94
King KDM 7000	2079	Commercial	Fast	-90	-95	-95	-95	-96
Narco 190	10617	General Aviation	Fast	-82	N/A			

<sup>a</sup>T.O. levels are the nominal sensitivity levels specified in manufacturers' data.

after acquisition has occurred than it is in the search mode. Therefore, testing interrogators under an acquisition criterion is the worst-case situation. This is not the case for the NARCO 190. Since the NARCO 190 has no lock-on feature, the fact that the NARCO 190 acquires on an individual trial conveys little information. This is contrasted to the other types of interrogators where acquisition of lock precludes any break-lock possibility unless the signal parameters change. Therefore, knowledge of acquisition can be used as an operational yardstick for all interrogators except the NARCO 190.

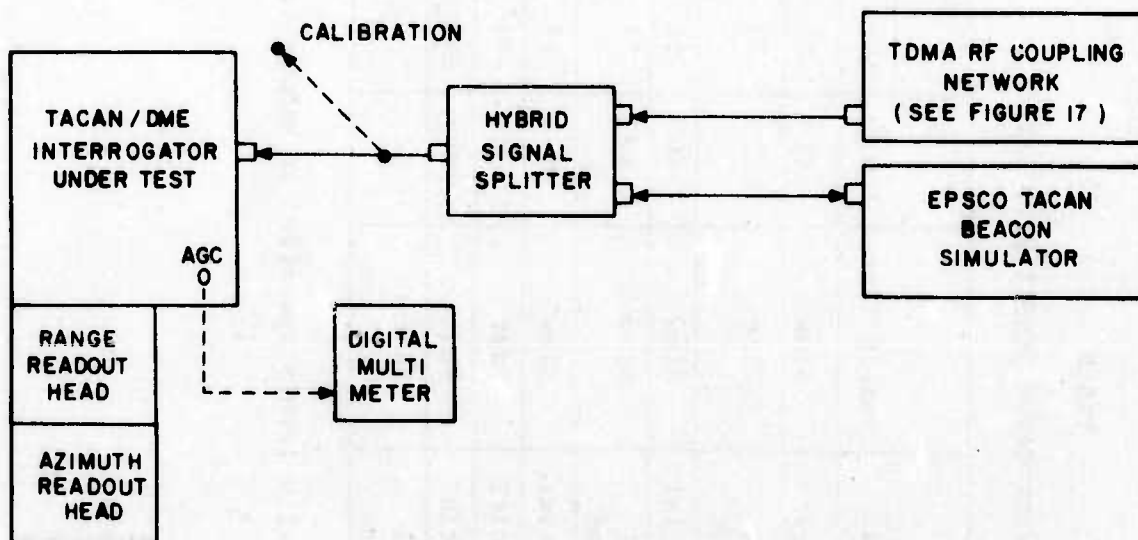

Figure 23. TACAN/DME interrogator test setup.

Rather than specify a time to acquire for the NARCO 190, the time it took to acquire was recorded as a function of TDMA interference level. The procedure was as follows. For a fixed TDMA level, the NARCO 190 was placed in its initial state by tuning to an adjacent channel and then returning to the original channel. The time that elapsed until the correct range was displayed was recorded. This was repeated 25 times for each TDMA level examined.

An interference condition was assumed to exist if the average time to acquire range with interference present exceeded the average time to acquire with no interference present by an amount greater than the standard deviation ( $\sigma$ ) of the no-interference results. Although this criterion is somewhat arbitrary, it is believed to be conservative.

A special test set-up was required to record the acquisition time of the NARCO 190, which often was less than 1 second. The basic test set up is shown in Figure 24. A counter/timer was connected to the NARCO 190 digital readout display. It was connected such that the timer is gated "on" when all bars are displayed and gated "off" when a distance is displayed (the voltage of a bar is different from a number). Changing the NARCO 190 channel and then changing it back causes the NARCO 190 to break lock, displaying bars, and it goes into a search mode, which turns the timer on. When the NARCO 190 acquires the beacon signal, a distance is displayed and the timer is gated "off". The time the NARCO 190 took to display the desired signal is then displayed on the counter.

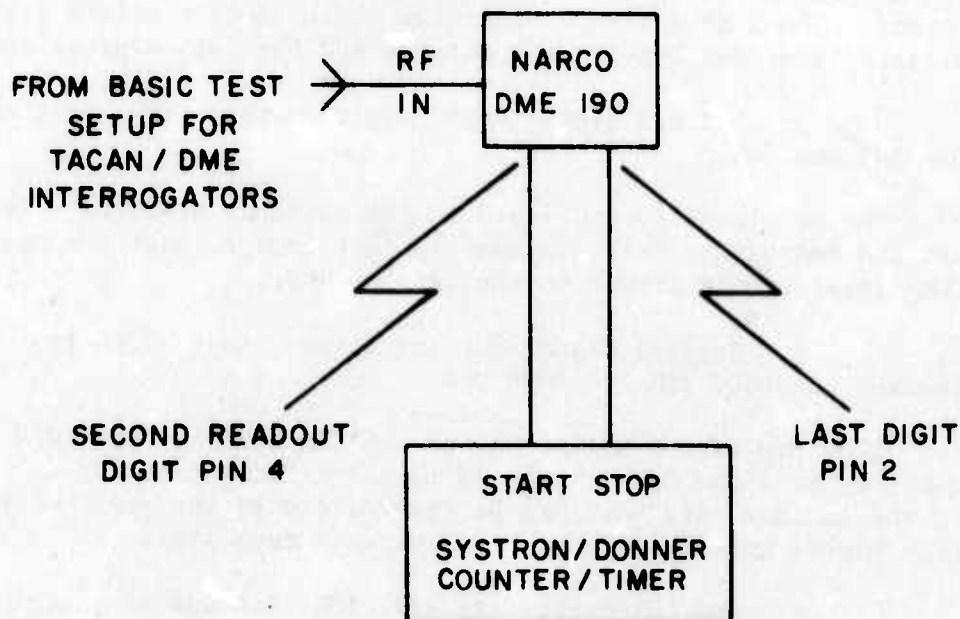

Figure 24. Special NARCO DME 190 test set-up.

Sensitivity Measurement

For the interrogator tests, sensitivity (MDS) is defined as the minimum desired-signal level that permits the interrogator to acquire lock in 15 or 30 seconds (depending on whether the search is fast or slow), and to retain lock for one minute. The MDS measurement was performed in a manner similar to the standard TDMA test illustrated in Figure 23. The only difference was that the TDMA level was held constant at -120 dBm and the desired signal level was varied. The sensitivity measurement was repeated three times to insure reliability. The MDS results for each interrogator

except the NARCO 190 are shown in TABLE 2. The NARCO 190 became very erratic with weak signal levels. Because of this, the NARCO 190 tests were not conducted at levels near MDS.

*Parameter Variations for Interrogator Sensitivity Tests.* Data was taken for the following parameter variations.

1. Desired signal levels (5): MDS + 1, (T.O.), -78.5 dBm, -78.5 dBm with 3 dB Pad, and -78.5 dBm with 9 dB Pad.

MDS + 1 dB was taken to represent the worst case situation of a weak signal. The T.O. level was taken to represent a level as specified by the equipment manufacturer. The -78.5 dBm level is the minimum level specified by FAA within a beacon's service volume. The 3-dB and 9-dB pads were employed to simulate transmission line loss between the antenna and the interrogator receiver.

2. Desired Signal Reply efficiencies: 70%, spot checked for 50% and 60%.

The 70% level is specified in the national standard. The 50% and 60% values were examined to take into account the possible TDMA interference effect on the TACAN beacon.

3. Desired signal PRF (Squitter rate): 2700 pps, spot checked for 1000 pps and 4000 pps.

2700 pps is the normal PRF of a TACAN beacon. The 1000 pps squitter rate can be transmitted by a DME beacon and the 4000 pps is the maximum rate that can be transmitted by the modified beacon (the higher rate is necessary to increase capacity).

4. DME Channels: (4) 18X, 19X, 33X and 53Y. 18X and 19X were used to assess the effect of the narrowband TDMA signal on the closest DME channels. 33X was used to assess the effect of wideband TDMA in X mode and 53Y was used for the effect of wideband TDMA in Y mode.

5. TDMA Mode: wideband and narrowband

6. TDMA Duty factor: 50%, spot checked for 25% and 10%.

In the event that the MDS Level of the receiver under test was less than -78.5 dBm, the desired signal levels considered were limited to MDS + 1 dB and MDS + 3 dB. As can be noted from TABLE 2, this was necessary for the KDM 705 and the UDI-4. In the case of the NARCO 190 system, data were taken for all indicated signal levels except MDS + 1 dB.

IFF TRANSPONDER

The parameters that were measured for the IFF transponder test were the number of desired and spurious replies that were transmitted by the transponder as the TDMA interference was varied.

The test setup is shown in Figure 25. The SQUAWK NAUT test set was employed in order to generate the desired IFF interrogator signal. The signal from the SQUAWK NAUT was coupled with the TDMA signal using the hybrid and the combined signal was fed into the IFF transponder under test. All replies transmitted by the transponder under test were detected by the SQUAWK NAUT and the reply video was made available through a front panel connector. Since the replies, especially in response to a mode C interrogation, consisted of more than one pulse, it was necessary to convert the entire reply to a single pulse before a counter could be employed. This was accomplished by putting the reply video into a channel of a 535A Tektronix scope and counting the single pulse gate output.

The spurious reply count was accomplished by attenuating the desired signal and varying the TDMA. No AND gate was available for the test. Instead, the synchronous replies were approximated by subtracting out the spurious replies from the total replies. That is, the total replies were counted and the TDMA contribution to the total replies, which was measured in the spurious reply test, was subtracted to yield the synchronous reply count. It is pointed out that this technique is only a first-order approximation to the synchronous reply count.

Sensitivity Measurement

The sensitivity of an IFF transponder, which is defined as the 90% reply efficiency point, is specified to be between the limits of -69 and -77 dBm at the antenna terminals. A 3-dB line loss is specified and as a result the desired sensitivity under test conditions (no antenna or line loss) should be between -72 and -80 dBm.

The sensitivity was measured in both mode 3A and mode C using a desired interrogation rate of 200 pps. The particular reply code used was immaterial. The results of the MDS measurements are shown in TABLE 3.

As can be seen from the table the GENAVE 4096 did not meet the national standard (Reference 1). At the point in time when this was discovered it was not possible to contact FAA representatives. After the testing was completed, FAA representatives

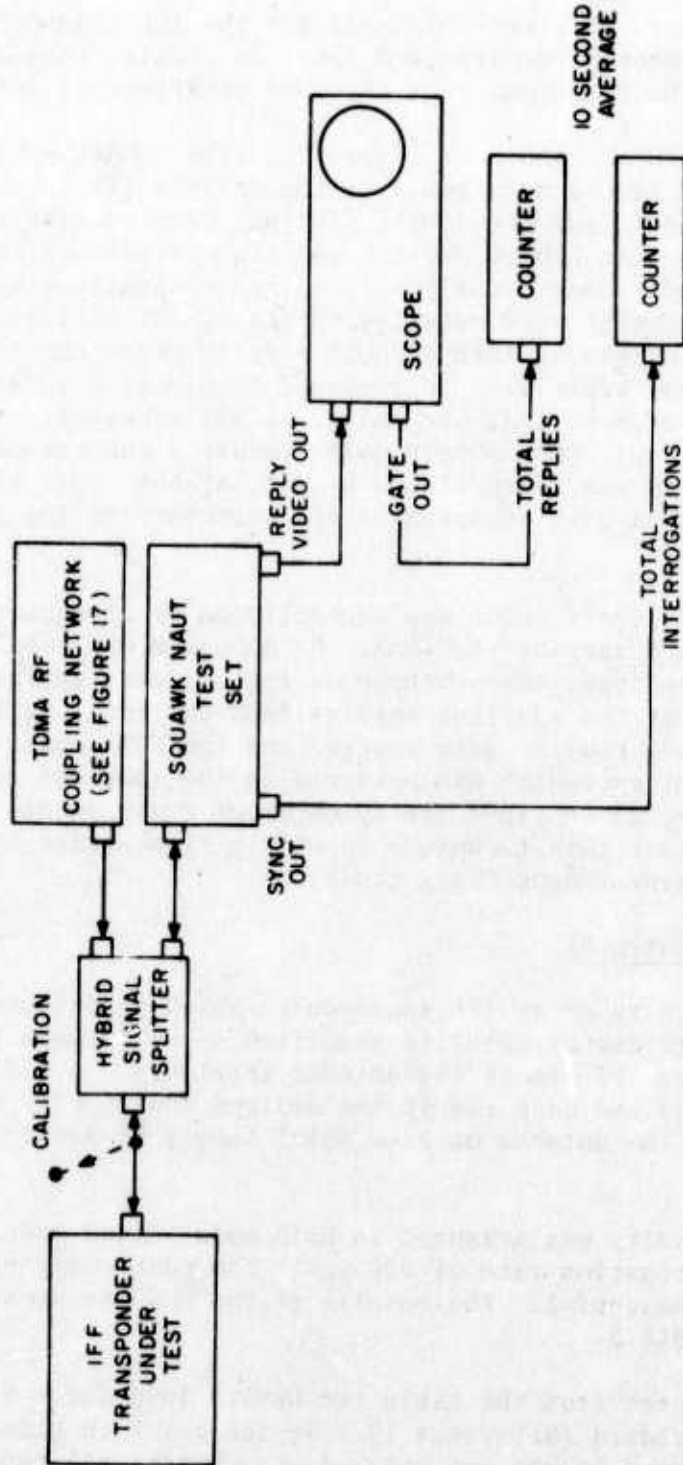

Figure 25. IFF transponder test setup.

were notified and because of the little time remaining the decision to limit the data to that already taken was made. It is pointed out that the effect on the test results of the equipment not performing to the national standard is unknown.

TABLE 3

## IFF TRANSPONDER MDS LEVELS

Nomenclature	Type	MDS (dBm)	
		Mode 3A	Mode C
AN/APX-72	Military	-79.4	-79.4
Collins 621A-6	Commercial	-74	-74
Genave 4096	General Aviation	-65	Did not work in mode C.
Regency 5051	General Aviation	-74	-74

*Parameter Variations for IFF Transponder Test.*

1. Desired signal levels dBm: MDS and others as required
2. TDMA mode: Wideband and narrowband
3. TDMA duty factor: 50%, spot checked for 25%
4. Desired PRF: 200 pps
5. IFF mode: 3A and C.

IFF INTERROGATOR

Testing was performed on two IFF interrogators, an ARTCBI-3 and an ARTCBI-4. The ARTCBI-3 has a vacuum tube receiver and the ARTCBI-4 has a solid state one. The two tests are considered separately.

ARTCBI-4 Test

In the ARTCBI-4 test the parameters that were measured were the number of desired and spurious decodes that were processed through the ARTCBI-4's receiver as a function of TDMA interference. In addition to reply count data, video scope photos were taken as the TDMA level was varied. The test was performed with the standby interrogator operating into a dummy load.

The test set-up is shown in Figure 26. The ATC Beacon Test Set provides the equivalent of the transponder reply pulses. These modulate an RF source generated by the HP-612A signal generator using the HP-8403A PIN diode modulator. The simulated transponder reply is added to the TDMA signal via the hybrid and fed into the RF directional probe built into the interrogator (J28). The reply is triggered by the beacon sync pulse at J25. This sync pulse is also used to trigger the oscilloscope so that the reply code and the interrogator receiver video may be displayed. The sync pulses are counted to provide the interrogation rate. A defruiter whose function has already been explained in the System Description Section may be manually switched in and out. Channel A of the oscilloscope displays the video output. With a switch on the interrogator R/T unit either raw video or quantized video may be displayed. Except while taking pictures quantized video was used for the tests. A decoder was connected via the patch panel. The decoder gives an output pulse whenever the transponder reply code from the video output line matches the code set on the decoder. The decoder output was fed into counter B in order to obtain the reply count. For the entire test, the sensitivity time control (STC) was turned off. All counters were set for a 10-second average reading.

The spurious decodes were counted by attenuating the desired signal and varying the TDMA level. An AND gate arrangement could not be employed for the test. Instead, the synchronous decodes were approximated by subtracting out the spurious decodes from the total decodes. That is, the total decodes were counted and the TDMA contribution to the total decodes, which was measured in the spurious decode test, was subtracted to yield the synchronous decode count. It is pointed out that this technique is only a first-order approximation to the synchronous decode count.

The test was performed with and without a defruiter in order to determine the defruiter's effect. Also three different reply codes were considered in order to determine if code content affected test results. The reply codes used were 0000 (just bracket pulses), 7700 (a pulse in every other position) and 7777 (all positions filled).

#### Sensitivity Measurement

The national standard defines interrogator sensitivity in terms of tangential sensitivity (signal equals noise) rather than a decoder reply efficiency. However, for the purpose of the test, sensitivity (MDS) was taken to be the desired signal level required to produce a 90% decode rate (out of decoder).

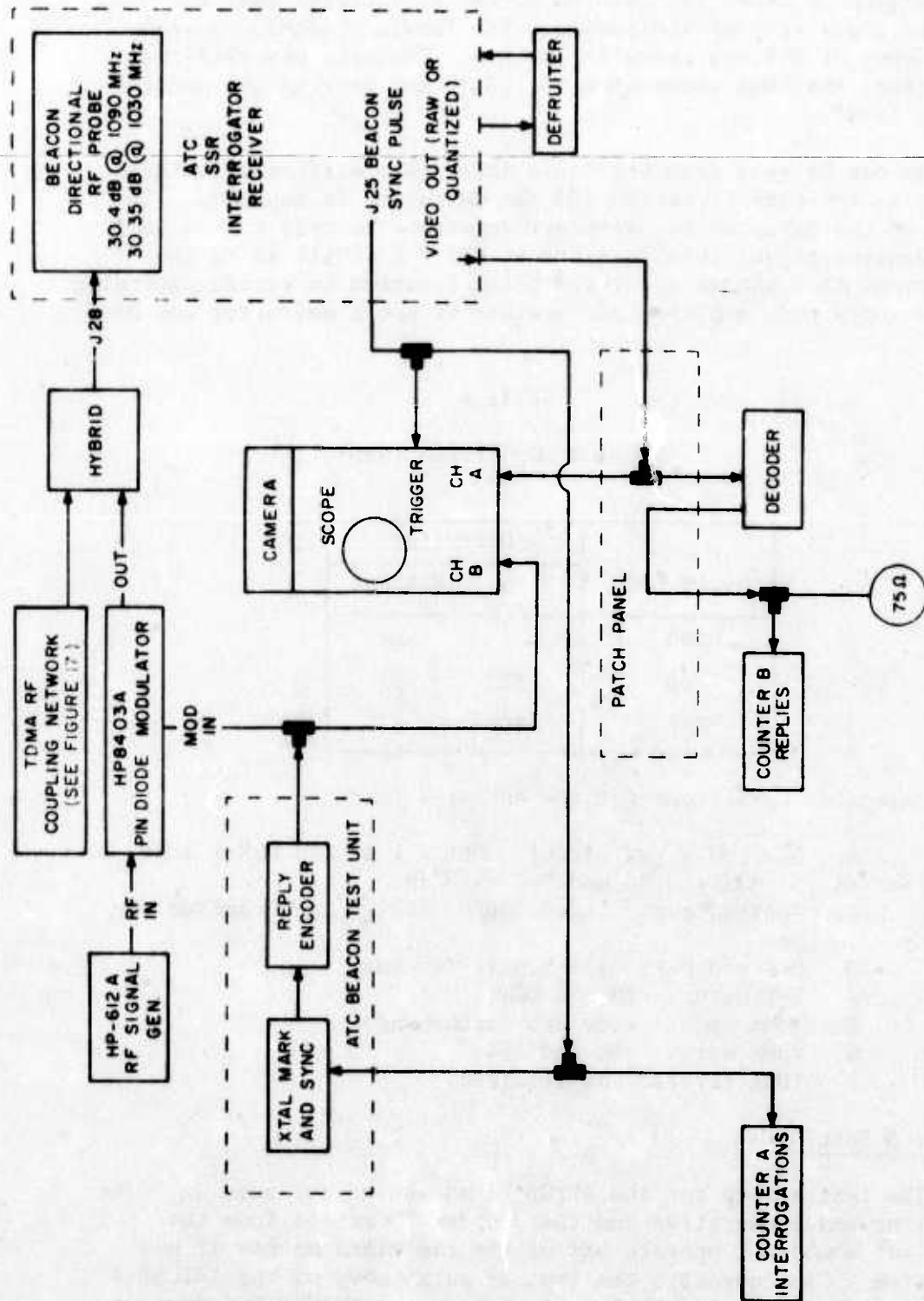

Figure 26. ARTCBI-4 test setup.

Figure 27 shows the results of the sensitivity test for a desired reply rate of 310/second. The levels producing a reply efficiency of 90% are shown in TABLE 4. The data was obtained by setting the TDMA attenuator to 120 dB and varying the HP612A output level.

As can be seen from the table there is a difference between levels as the code is varied and the defruiter is employed. Because of the differences, whenever reference is made to MDS (e.g. "the desired signal level was set at MDS + 1 dB") it is to be understood that the actual level being referred to varied depending on the reply code employed and whether or not a defruiter was used.

TABLE 4  
ARTCBI-4 MDS LEVELS (dBm)

Reply Code	Defruiter	
	With	Without
0000	-82	-84
7700	-81	-83
7777	-80	-82

*Parameter Variations for the ARTCBI-4 Test.*

1. Desired signal level: MDS + 1 dB and MDS + 3 dB. Spot checked for MDS + 6 dB and MDS + 10 dB.
2. Desired reply code: 0000, 7777. Spot checked for 7700.
3. Desired PRF: 310 replies/second.
4. Defruiter: IN AND OUT.
5. TDMA mode: wide and narrowband.
6. TDMA duty: 50% and 25%.
7. TDMA levels: as required.

ARTCBI-3 Test

The test set-up for the ARTCBI-3 as shown in Figure 28. The defruiter was inoperative and the decoder (borrowed from the ARTCBI-4) would not operate off of the raw video unless it was defruited. Consequently, the type of data taken on the ARTCBI-4 (decoder counts) could not be repeated on the ARTCBI-3. However, video photos were taken as the TDMA level was varied, in the same manner as was done on the ARTCBI-4.

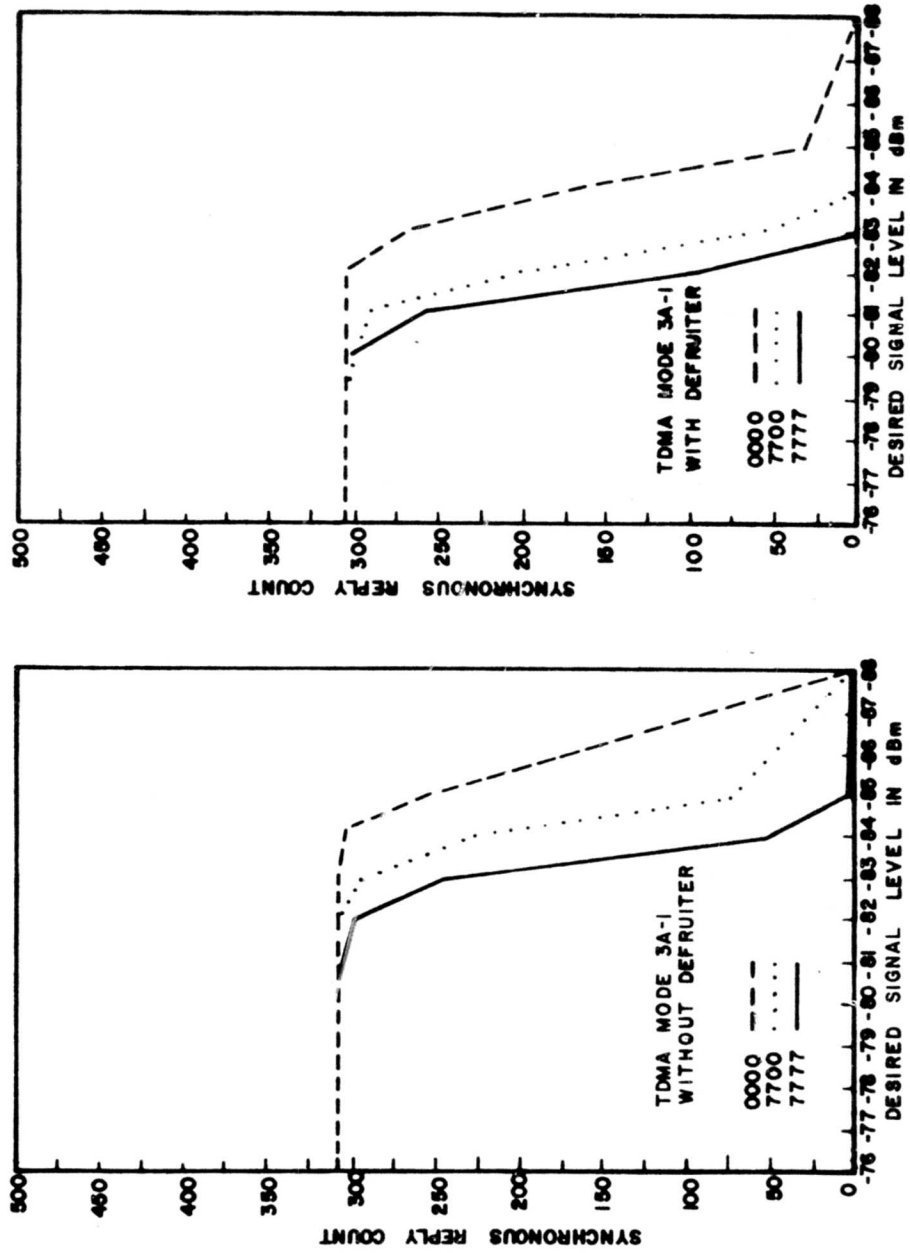

Figure 27. ARTCBI-4 receiver sensitivity data.

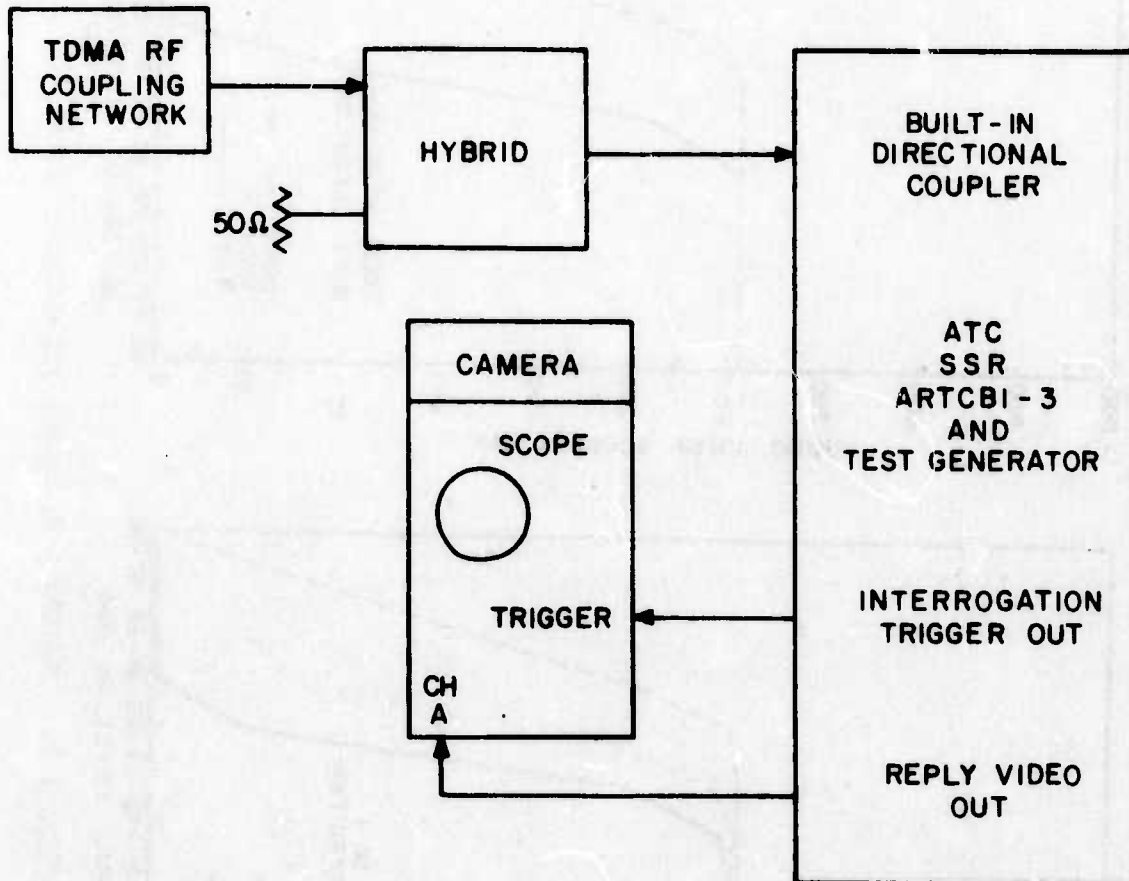

Figure 28. ARTCBI-3 test setup.

## SECTION 4

## INTERPRETATION OF DATA

INTRODUCTION

All of the data taken in the NAFEC JTIDS tests is shown in graphical form in APPENDIXES B through H. This section highlights the major results. On each of the graphs in this section, a distance-separation scale in nautical miles is shown. The separation distance, which is indicated between the JTIDS transmitter and the receiver under test, was calculated by assuming the JTIDS effective radiated power is 1 kW. Since the actual power is unknown, the actual distance separation can be derived for any radiated power by shifting the scale by the dB difference between the actual power (in dBm) and + 60 dBm (1 kW). The distance scales are intended as an aide in assessing the test results.

TACAN BEACON TEST RESULTSReply Efficiency Test

The results of the reply efficiency test are shown in APPENDIX B. The data is plotted in two different ways. In the first, the actual reply efficiency as a function of TDMA level is shown. The second method illustrates the percent change in reply efficiency as the TDMA level is varied from the no interference value.

In order to assess the impact of the TDMA waveform on the TACAN beacon performance, some type of criterion is required. At the present time, no criterion exists.

To aide in the interpretation of the results, two different criteria are considered. In the first, one can use the point at which the reply efficiency drops below the national standard of 70%. However, in the data taken, there was little consistency among the no-interference reply efficiencies of the beacons tested. In some instances the no-interference reply efficiency was close to 90% and in others it was close to 70%. Based on the 70% criterion, one beacon could tolerate a 20% reply efficiency drop and another beacon could tolerate a drop of only a few percent. Added to this initial uncertainty in actual reply efficiency is the possibility of future beacon improvements or modifications (such as the increased capacity feature of the experimental modified RTB-2 tested) which will reduce beacon reply efficiency.

The change in reply efficiency is useful in detecting whether the TDMA interference could affect beacon performance. The difficulty here is that no acceptable criterion for a change in reply

efficiency has been established with which to assess the effect of TDMA interference. The reason for this, as mentioned previously, is that the maximum reply efficiency under no interference is not standardized by specification and, consequently, an acceptable reply efficiency rate change based on the 70% minimum cannot be deduced. Also, if it is assumed that the beacon is operating with a minimum 70% reply efficiency (worst case), the amount of additional reduction that can be tolerated cannot be determined due to the fact that the safety margin originally designed into equipment so that it would meet the 70% national standard is not known. All of the equipment tested in the NAFEC test appeared to operate normally with a 60% reply efficiency. At 50%, operation was marginal for the AN/ARN-21C.

The data as it is plotted in APPENDIX B is without regard to any criteria. From the results it appears that the AN/GRC-9C receiver is the most vulnerable to TDMA interference. The AN/GRN-9C test results for a 50% TDMA duty cycle are shown in Figures 29 and 30.

In order to provide an aid in assessing the data, the distance separation required between the TDMA transmitter and the victim receiver to both reduce the reply efficiency below 70% (65% in Y mode) and also to produce a 5% change in reply efficiency, are shown in TABLE 5. These results are based on a 50% TDMA duty cycle. It can be seen that the AN/GRN-9C is the most vulnerable equipment, requiring (in one instance) a 50-nmi separation to prevent a 5% countdown. The modified RTB-2 (X and Y mode) and the Butler are less susceptible, requiring at most a 5-nmi separation to prevent a 5% countdown. The reason that the modified RTB-2 is resistant to the TDMA is that the echo suppression circuits are activated only by decodes. In the normal RTB-2 receiver the echo suppression is triggered by every pulse received. Since the echo suppression circuit produces dead time in the beacon receiver, the countdown is greatly reduced by triggering it only when the TDMA produces decodes. At present, it is not known why the AN/GRN-9C is more vulnerable to the TDMA interference than the normal RTB-2. The reason why the Butler equipment is resistant to the TDMA is also unknown.

The data trends as the parameters were varied are summarized below.

*TDMA duty cycle.* The change in reply efficiency was linear with duty cycle. Halving the duty cycle halved the countdown.

*Desired-signal level.* The reply efficiency appeared to improve noticeably when the desired-signal level was increased from MDS + 1 dB to MDS + 3 dB. However, when the data was normalized to the no-interference case, the actual change in reply efficiency was slight.

TABLE 5  
SUMMARY OF TACAN BEACON REPLY EFFICIENCY TEST RESULTS

Desired Signal Level	Condition for which the results are shown	Desired PRF (PPS)	Distance Separation in Nautical Miles (1 kW ERP, 50% duty cycle)																													
			AN/GRN-9C						RTB-2 X Mode						Modified RTB-2 X Mode						Modified RTB-2 Y Mode						Butler					
			TDMA Waveform			TDMA Waveform			TDMA Waveform			TDMA Waveform			TDMA Waveform			TDMA Waveform			TDMA Waveform			TDMA Waveform								
MDS+1dB	Reply efficiency reduced by 5%	1000	3A	2A	3B	2B	3A	2A	3B	2B	3A	2A	3B	2B	3A	2A	3B	2B	3A	2A	3B	2B	3A	2A	3B	2B						
		2700	30	20	20	20	2	*	*	*	*	1	*	*	*	*	2	*	*	*	*	*	*	*	*	*	*					
		3300	50	40	40	30	5	*	3	*	3	1	1	*	1	*	3	*	3	*	3	*	2	1	2	*	*					
	Reply efficiency is reduced to 70% (65% for Y mode)	1000	30	10	10	1	2	4	1	*	2	*	*	*	2	*	*	*	*	2	*	2	*	*	1	*	*					
		2700	20	10	10	3	1	1	*	1	*	1	*	*	*	1	*	*	*	Δ	Δ	Δ	Δ	1	*	*	*					
		3300	3	1	1	*	*	1	*	*	*	*	*	*	*	*	*	*	*	*	1	*	*	*	*	*	*	*				
MDS+3dB	Reply efficiency reduced by 5%	1000	3A	2A	3B	2B	3A	2A	3B	2B	3A	2A	3B	2B	3A	2A	3B	2B	3A	2A	3B	2B	3A	2A	3B	2B						
		2700	30	15	20	5	2	*	*	*	*	1	*	*	*	1	*	*	*	1	*	*	*	1	*	*	*					
		3300	40	40	40	10	5	*	2	*	3	1	2	*	2	*	3	1	2	*	2	*	1	*	2	*	*					
	Reply efficiency is reduced to 70% (65% for Y mode)	1000	30	5	7	3	*	*	*	*	*	*	*	*	2	*	*	*	*	3	1	*	*	*	*	*	*					
		2700	10	5	10	2	*	*	*	*	*	*	*	*	*	*	*	*	*	*	1	*	*	*	*	*	*					
		3300	5	*	*	*	*	*	*	*	*	*	*	*	*	*	*	*	*	*	*	*	*	*	*	*	*					

NOTES: \* - distance separation < 1 nm.  
Δ - results at or below 65% with no TDMA.

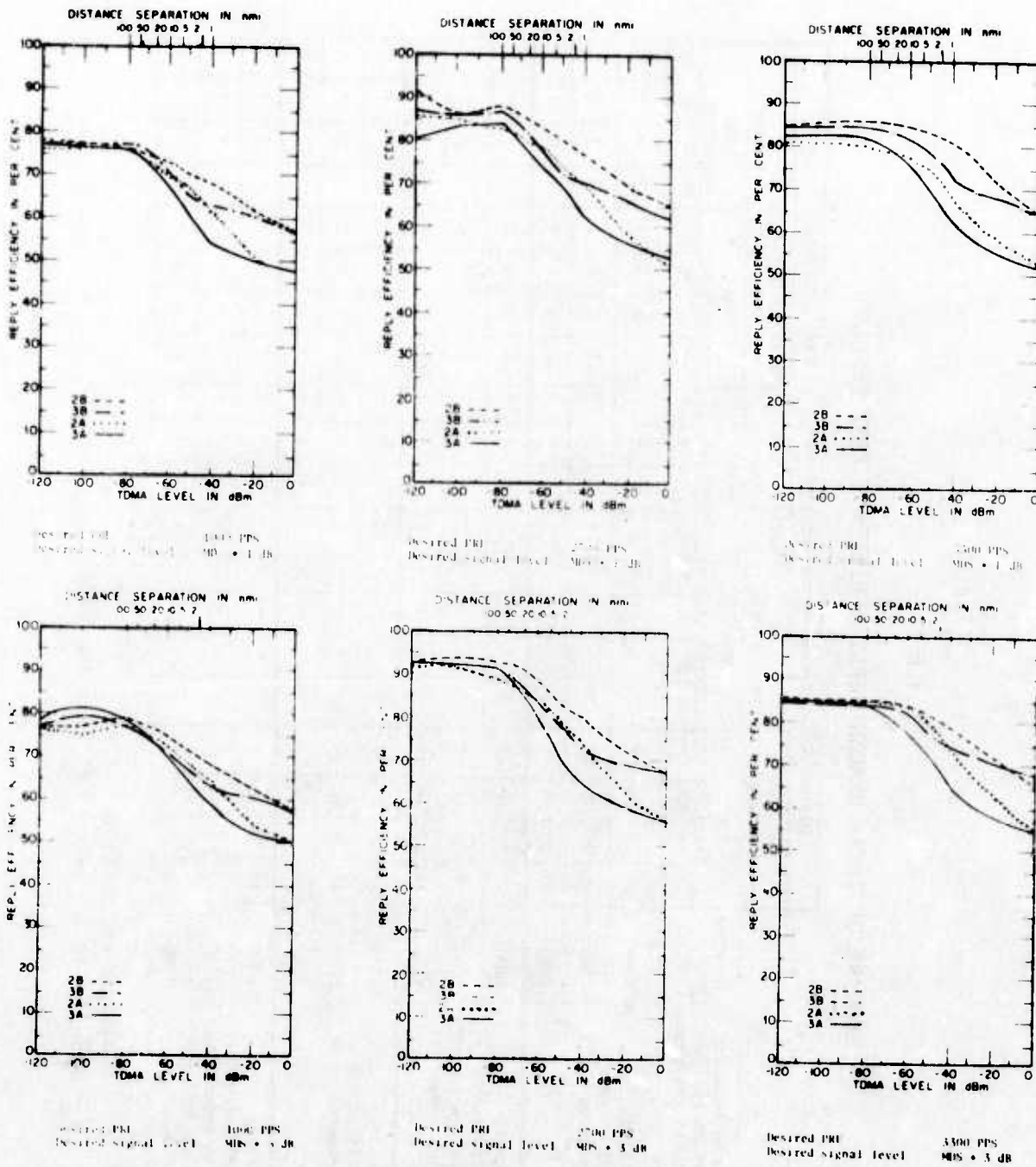
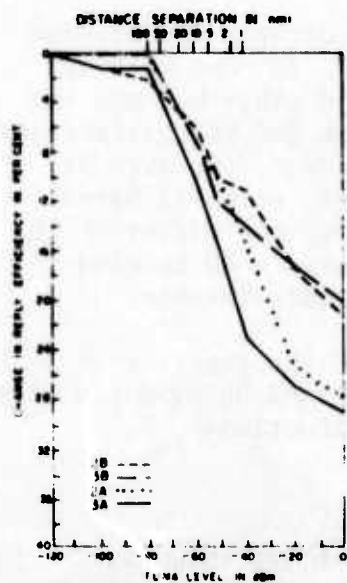
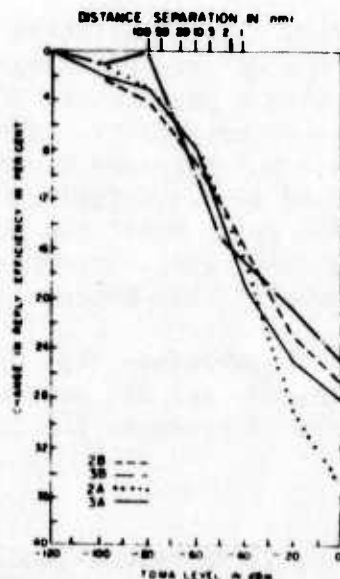

Figure 29. AN/GRN-9C beacon reply efficiency results for TDMA duty factor of 50%.



Desired PRI 1000 PPS  
Desired signal level MIS + 1 JB



Desired PRI 500 PPS  
Desired signal level MIS + 1 JB

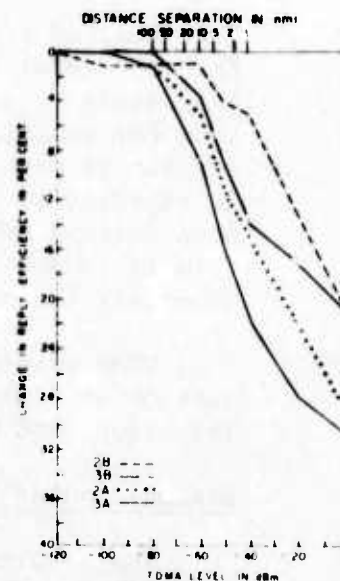

Desired PRI 500 PPS  
Desired signal level MIS + 2 JB

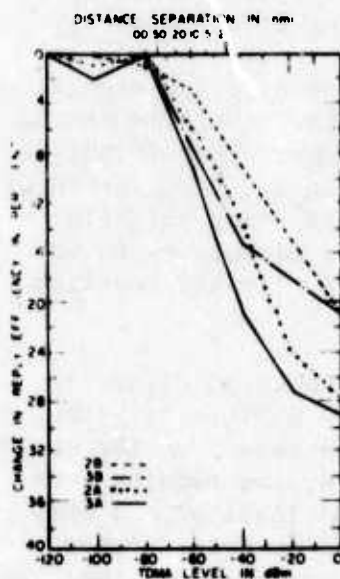

Desired PRI 1000 PPS  
Desired signal level MIS + 3 JB

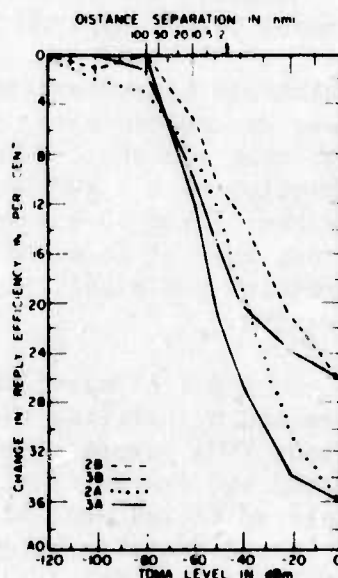

Desired PRI 2500 PPS  
Desired signal level MIS + 3 JB

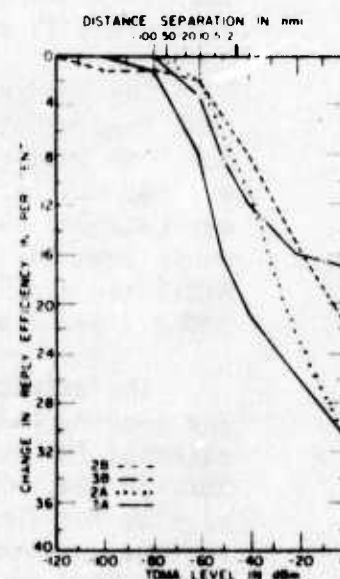

Desired PRI 3300 PPS  
Desired signal level MIS + 3 JB

Figure 30. AN/GRN-9C beacon change in reply efficiency results for TDMA duty factor of 50%.

*Desired signal PRF.* There is little or no correlation between the test results and the desired PRF range used. In some beacons, the results improved with a particular PRF and in other beacons the same PRF maximized the vulnerability. The reason for the variability of results with PRF was not examined during the test. However it is expected to be linked to the definition of MDS, which is based on a desired PRF of 400 pps. Until the reason for the different PRF results is determined, the worst-case PRF results should be used in assessing the performance of the beacon to TDMA interference.

*TDMA waveforms.* The waveform that produced the greatest reduction in reply efficiency was 3A; waveforms 2A and 3B produced less reduction; and waveform 2B produced the least reduction.

#### Beacon-Loading Test

The results of the TACAN beacon-loading test are shown in APPENDIX C. The results shown for the RTB-2 and AN/GRN-9C require some explanation to interpret the data on TDMA signal decoding by the beacon receiver. However, the results for the Butler and modified RTB-2 (X and Y mode) beacon show the loading effect directly.

The loading results can be summarized as follows: No significant loading effect was discovered with any of the waveforms tested for TDMA levels weaker than -40 dBm. This threshold corresponds to a 1-nmi distance separation of a 1 kW TDMA terminal. Also, decoding was detected only for the 3A and 3B waveforms, 3A being slightly worse than 3B. The remainder of this subsection elaborates on the RTB-2 and AN/GRN-9C results and highlights the Butler and modified RTB-2 X and Y mode results.

The results for the RTB-2 3A waveform are shown in Figure 31. The loading was determined by plotting the reply efficiency versus external PRF for various TDMA levels. As can be seen from the curves for -80 dBm, -70 dBm and -60 dBm external levels, the results were similar for TDMA levels up to -40 dBm. At a TDMA level of -20 dBm, the curves deviated. The difference between the no interference curve (TDMA = -120 dBm) and the TDMA = -20 dBm curve is greater than the difference between the -120 dBm curve and the -20 dBm curve on the plot for an external level of -135 dBm. The additional countdown results from overloading the beacon. No assessment of the number of TDMA decodes could be made from the test. The 3B waveform result is similar to the 3A waveform result. For the 2A and 2B waveforms, the results actually indicate an unloading effect. That is, the reply efficiency with large TDMA level was greater than with no TDMA interference (-120 dBm) as the external PRF was varied.

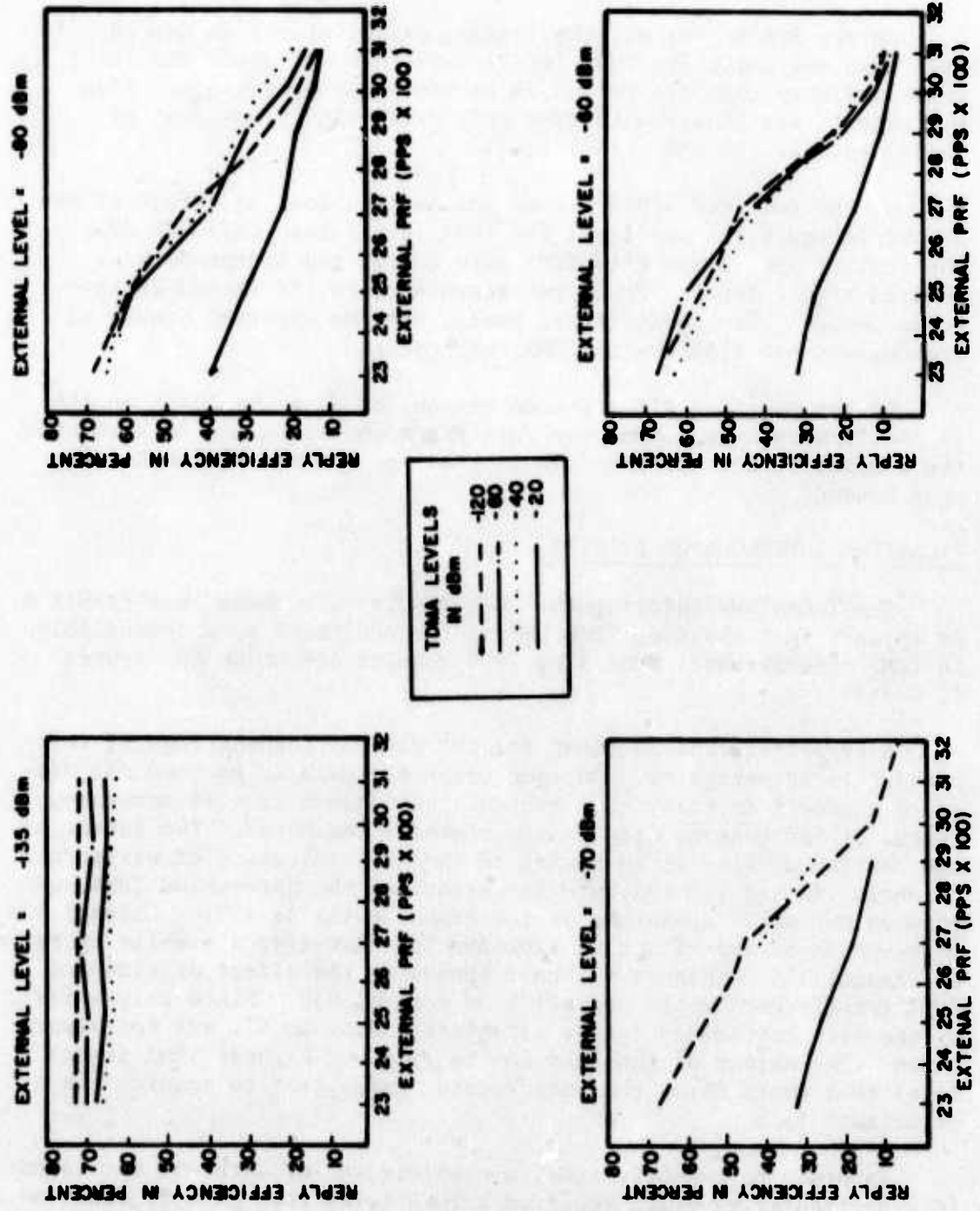

Figure 31. RTB-2 beacon loading results for waveform 3A (50% TDMA duty cycle, desired-signal level MDS + 1 dB, PRF 500 pps).

On the AN/GRN-9C beacon, no TDMA decoding was apparent for any of the waveforms tested.

On the Butler beacon, the loading effect of the 3A and 3B waveforms was small for TDMA levels less than -40 dBm. The results indicate that the 2A and 2B waveforms do not decode. Also the results are linear with TDMA duty cycle and independent of desired-signal PRF and signal level.

On the modified RTB-2 X-mode beacon, the loading effect of the 3A and 3B waveforms was small for TDMA levels less than -40 dBm. The results are linear with TDMA duty factor and independent of desired-signal level. It is not known whether the 2A and 2B waveforms decode. Their effect was small, but the apparent number of decodes was not linear with TDMA duty cycle.

On the modified RTB-2 Y-mode beacon, no data was taken on the 2A and 2B waveforms. From the data taken on the 3A and 3B waveforms, the loading effect was the same as that for the modified RTB-2 X mode beacon.

#### TACAN/DME INTERROGATOR RESULTS

The TACAN/DME interrogator test results are shown in APPENDIX D. It appears that the King 7000 DME is the equipment most susceptible to TDMA interference. The King 7000 results are shown in Figures 32 and 33.

A separate graph is shown for the several combinations of test parameters investigated. *On each graph the data is plotted for discrete channels so that, even though a continuous line is sometimes shown, it has meaning only at the channels indicated.* The intent of the continuous line is to assist in the identification of waveforms. Channels 18X and 19X indicate the effect of the narrowband TDMA waveform on DME while operating on the channels 18X or 19X. Channel 33X corresponds to the effect of wideband TDMA interference while operating on channel 33X. Channel 53Y corresponds to the effect of wideband TDMA interference while operating on channel 53Y. Since only a few of the sets tested had Y-mode capability, data on 53Y was not always taken. The object of the test was to find the highest TDMA signal level that would allow the interrogator under test to acquire range or azimuth lock.

In order to conserve time, a complete set of data was not taken. If a particular waveform required a TDMA level less than or equal to -40 dBm (corresponding to 1 nmi distance separation), lesser points (i.e., stronger desired signal levels) and smaller TDMA duty factors



--- 2A  
 - - - 2B  
 - - - 3A  
 - - - 3E

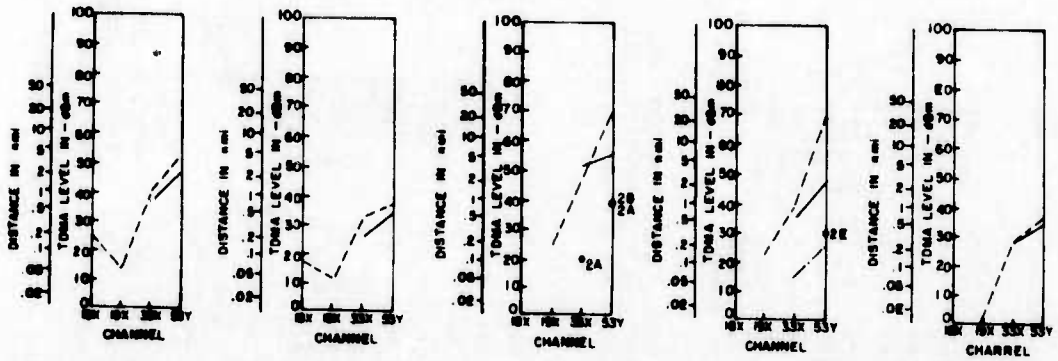

SIGNAL LEVEL <u>T.O.</u>	SIGNAL LEVEL <u>T.O.</u>	SIGNAL LEVEL <u>MDS + 1</u>	SIGNAL LEVEL <u>MDS + 1</u>	SIGNAL LEVEL <u>-78.5</u>
REPLY EFF. <u>70%</u>	REPLY EFF. <u>70%</u>	REPLY EFF. <u>70%</u>	REPLY EFF. <u>70%</u>	REPLY EFF. <u>70%</u>
SQUIT RATE <u>2700</u>	SQUIT RATE <u>2700</u>	SQUIT RATE <u>2700</u>	SQUIT RATE <u>2700</u>	SQUIT RATE <u>2700</u>
DUTY FACTOR <u>25%</u>	DUTY FACTOR <u>10%</u>	DUTY FACTOR <u>25%</u>	DUTY FACTOR <u>10%</u>	DUTY FACTOR <u>25%</u>

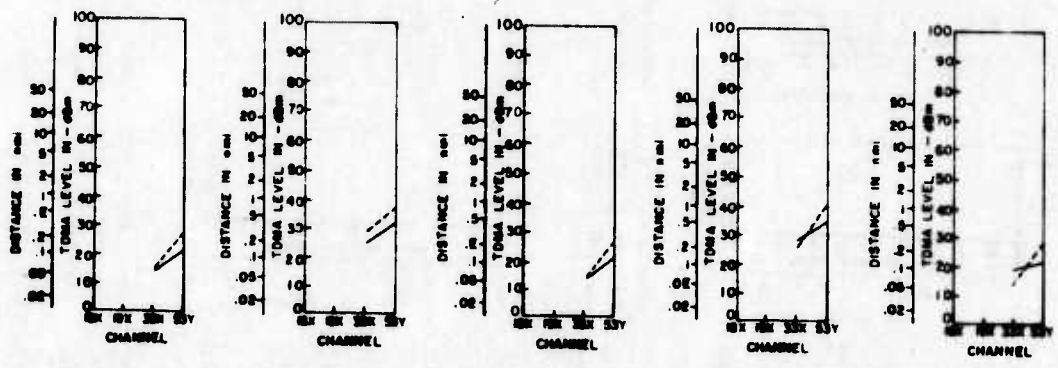

SIGNAL LEVEL <u>-78.5</u>	-78.5 dBm WITH SIGNAL LEVEL <u>3dB PAD</u>	-78.5 dBm WITH SIGNAL LEVEL <u>3dB PAD</u>	-78.5 dBm WITH SIGNAL LEVEL <u>9dB PAD</u>	-78.5 dBm WITH SIGNAL LEVEL <u>9dB PAD</u>
REPLY EFF. <u>70%</u>	REPLY EFF. <u>70%</u>	REPLY EFF. <u>70%</u>	REPLY EFF. <u>70%</u>	REPLY EFF. <u>70%</u>
SQUIT RATE <u>2700</u>	SQUIT RATE <u>2700</u>	SQUIT RATE <u>2700</u>	SQUIT RATE <u>2700</u>	SQUIT RATE <u>2700</u>
DUTY FACTOR <u>25%</u>	DUTY FACTOR <u>25%</u>	DUTY FACTOR <u>10%</u>	DUTY FACTOR <u>25%</u>	DUTY FACTOR <u>10%</u>

Note: MDS level varies with channel number. For MDS and T.O. levels, refer to TABLE 2, Section 3.

Figure 33. King 7000 SN 1993 test results continued.

were not necessarily examined. Also, in many instances, if a 3A or 3B waveform was less than -40 dBm, data was not taken on the corresponding lesser waveform, 2A or 2B.

#### Interference Trends

*Desired signal level.* The stronger the desired signal level, the more resistant the victim receiver was to the TDMA signal. At desired signal levels of MDS + 1 dB, some of the DME receivers were particularly susceptible to interference. This was due primarily to the fact that the measured MDS was considerably below the manufacturer's specified MDS (T.O.).

*TDMA duty factor.* In general, as the TDMA duty cycle was decreased, the TDMA level required to prevent the interrogator from acquiring lock increased. From the data, the relationship between the increase in TDMA level required to prevent acquisition, and the decrease in duty cycle, was not linear. The reason duty factor linearity could not be determined was due in part to the limited amount of data taken for the 25% and 10% duty factors. On the Collins 860-E2, the King 705, and the AN/ARN-21C, data for the 25% and 10% duty cycles were only examined for a desired signal level of MDS + 1 dB. These results were extremely nonlinear. The data on the UDI-4 and the RCA-AVQ-70 was limited solely to the 50% TDMA duty cycle. Only on the King KDM-7000 was a complete set of data taken. This data indicated a linear relationship only with the 50% and 25% duty cycles and not with the 10% duty cycle. Even this limited relationship did not hold for the MDS + 1 dB desired signal level.

*TDMA waveforms.* The relative effects of the TDMA waveforms, ranked from worst to best, are 3A, 3B, 2A and 2B.

*Reply efficiency.* In general, reply efficiency did not have a great effect on interrogator susceptibility levels. There were a few cases where reply efficiencies of 50% and 60% produced worse results than at 70%. In these situations the interrogator was usually having trouble acquiring lock without interference present.

*Squitter rate.* There was a slight tendency for the DME receiver to be more resistant to TDMA interference at a 1000 pps desired squitter rate than it was at a 2700 pps rate, and less resistant to TDMA interference at a 4000 pps rate than it was at 2700 pps. However, in most cases, these trends were not significant.

*X or Y mode of operation.* The results indicated that the Y mode of operation is more vulnerable to TDMA interference than is the X mode of operation. This is due to the fact that the adjacent-frequency restriction built into the TDMA simulator provided a certain amount of protection against producing false 12- $\mu$ s pulse

pair decodes in the X mode receiver. To afford the same protection to the 30- $\mu$ s Y mode spacing, or any other pulse spacing that may be employed in the TACAN system in the future, a different frequency-inhibiting scheme must be developed.

*3- or 9-dB Pads.* The introduction of line loss had no effect on the results until the pad was sufficient to reduce the desired signal to near MDS levels. At this point the set is extremely susceptible to TDMA interference. The test results for each of the interrogators tested are summarized in the following paragraphs. The results are qualitatively based on a 1-nmi separation between the TDMA terminal employing a 50% duty cycle and the victim TACAN/DME interrogator. This distance separation is somewhat arbitrary. It is based on a "reasonableness" criterion, developed after considerable discussion during the meetings of the Government Advisory Group (GAG).

a. King KDM 7000 SN 1993. All TDMA narrowband waveforms required less than a one nautical mile distance separation from the KDM 7000 operating with the manufacturer's specified minimum desired signal (T.O.). For X-mode operation, the TDMA wideband 2A and 2B waveforms both required less than a 1-nmi distance separation; however, the TDMA wideband 3A and 3B waveforms required a distance separation greater than 1 nmi. For Y-mode operation, the TDMA wideband 2B waveform required a 1-nmi separation and the 2A, 3B and 3A waveforms required a distance separation greater than 1 nmi. With the KDM 7000 operating with the minimum desired-signal level specified by the FAA of -78.5 dBm in X mode, all wideband TDMA waveforms required less than a 1-nmi distance separation. For Y mode operation, the wideband 2A and 2B waveforms required less than 1 nmi, the wideband 3B waveform required 1 nmi, and the 3A required slightly greater than 1 nmi. With a desired signal level of MDS + 1 dB in X mode operation, the wideband 2B waveform required a separation less than 1 nmi, while the 2A, 3B and 3A wideband waveforms required separations greater than 1 nmi. For Y mode operation all wideband waveforms required separations greater than 1 nmi.

b. King KDM 7000 SN 2079. Due to the susceptibility of the King KDM 7000 SN 1993, another sample was tested. The results of SN 2079 were comparable to SN 1993.

c. Collins 860-E2. All narrowband TDMA waveforms required less than a 1 nmi distance separation. Except for the MDS + 1 dB desired signal level all wideband waveforms for both X and Y mode operation required a distance separation less than or equal to 1 nmi. For the MDS + 1 dB desired signal level all wideband waveforms required separations greater than 1 nmi for both X and Y mode operation.

d. RCA AVQ-70. The RCA-AVQ-70 did not have Y mode capability. All TDMA narrowband and wideband test data indicated that a distance separation less than 1 nmi was required for compatible operation.

e. AN/ARN-21C. For the AN/ARN-21C, two separate tests were performed. One was based on range acquisition and the other was based on azimuth acquisition. The AN/ARN-21C does not have Y mode capability.

Before the range acquisition results can be summarized it is necessary to point out data points which were not consistent with the rest of the test data. There were five such points, indicated below by desired signal level, desired reply efficiency, desired squitter rate, TDMA waveform and DME channel:

1. -78.5 dBm, 70%, 4000, 3B and channel 33X
2. T.O., 70%, 4000, 3A and channel 33X
3. -78.5 dBm, 60%, 2700, 3B and channel 18X
4. -78.5 dBm, 60%, 2700, 3B and channel 19X
5. MDS + 1 dB, 70%, 2700, 2A and channel 33X.

Since the AN/ARN-21C tested had considerable difficulty acquiring range on channel 18X with a 50% reply efficiency and no TDMA interference present, all 50% data is suspect.

If inconsistent data points and the data for 50% reply efficiency are ignored, all of the TDMA wideband and narrowband waveforms tested required less than a 1 nmi distance separation.

There is one inconsistent data point in the azimuth acquisition data.

MDS + 1 dB, 70%, 2700, 2A and channel 33.

If this inconsistent data point is eliminated, all of the TDMA wideband and narrowband waveforms tested required less than a 1-nmi distance separation.

f. NARCO 190. Two questionable data points were detected:

- 78.5 dBm, 70%, 4000, 2A, and channel 33X
- 78.5 dBm with 9-dB pad, 70%, 2700, 3A and channel 33X.

The first of these is inconsistent with other data. In the second case, the 9-dB pad attenuated the signal 5-dB below the manufacturer's specified minimum desired-signal level (T.O.), and the point should be discarded.

If these questionable data points are ignored, all of the TDMA wideband and narrowband waveforms tested required a distance separation of one nautical mile or less.

g. NARCO UDI-4 and King KDM-705. All of the wideband and narrowband waveforms tested required a distance separation less than one nautical mile.

#### DIGITAL DATA BROADCAST RESULTS

The Digital Data Broadcast (DDB) results are shown in APPENDIX E. The wideband TDMA results for a 50% TDMA duty cycle and desired signal levels of MDS + 2 dB and MDS + 10 dB are shown in Figures 34 and 35, respectively. The data was plotted for each of the six parameters examined. It is characterized by a break point, beyond which performance drops off rapidly with increasing TDMA level.

The performance criterion for the DDB results has been assumed to be the location of the break point on the "Good Words" graph. As has been mentioned in Section 3, the "Good Words" count is the best performance measure of the system as it is presently designed.

Based on this criterion, the distance separations required for a desired signal level at MDS + 2 dB are 10 nmi and 2 nmi for wideband and simulated narrowband TDMA operation, respectively. The results are linear with increasing desired signal level. For a desired signal level of MDS + 10 dB, the corresponding distance separations are 3 nmi and less than 1 nmi. Although the location of the break point was the same for all waveforms tested, the effect of the waveforms differed as the TDMA level was increased. They are ranked as follows from worst to best: 3A, 3B, 2A and 2B.

The location of the break point when the TDMA duty cycle was reduced to 25% was approximately the same as the 50% results. In general, the effect of duty cycle as the TDMA level was increased beyond the break point was fairly linear for the DATA A, DATA B and Sync pulses. It was not linear for the Sync groups, Good Words, and Words passing parity and bit count.

The data taken on spurious DATA A, DATA B and Sync pulses that were caused by the TDMA interference indicated that the number of spurious TDMA decodes was small for TDMA levels less than -30 dBm (corresponding to a distance separation less than 1 nmi). The results indicated that the spurious count was independent of the desired-signal level. Although the spurious decodes were few in number, their overall effect on the system performance (Good Words) could have been significant. This is because every extraneous DATA A or DATA B bit could prevent a complete word from being processed.

The DDB display was monitored as described in Section 3. In general, the acquired, partially-acquired and not-acquired condition of the display correlated with the following Good Word count range:

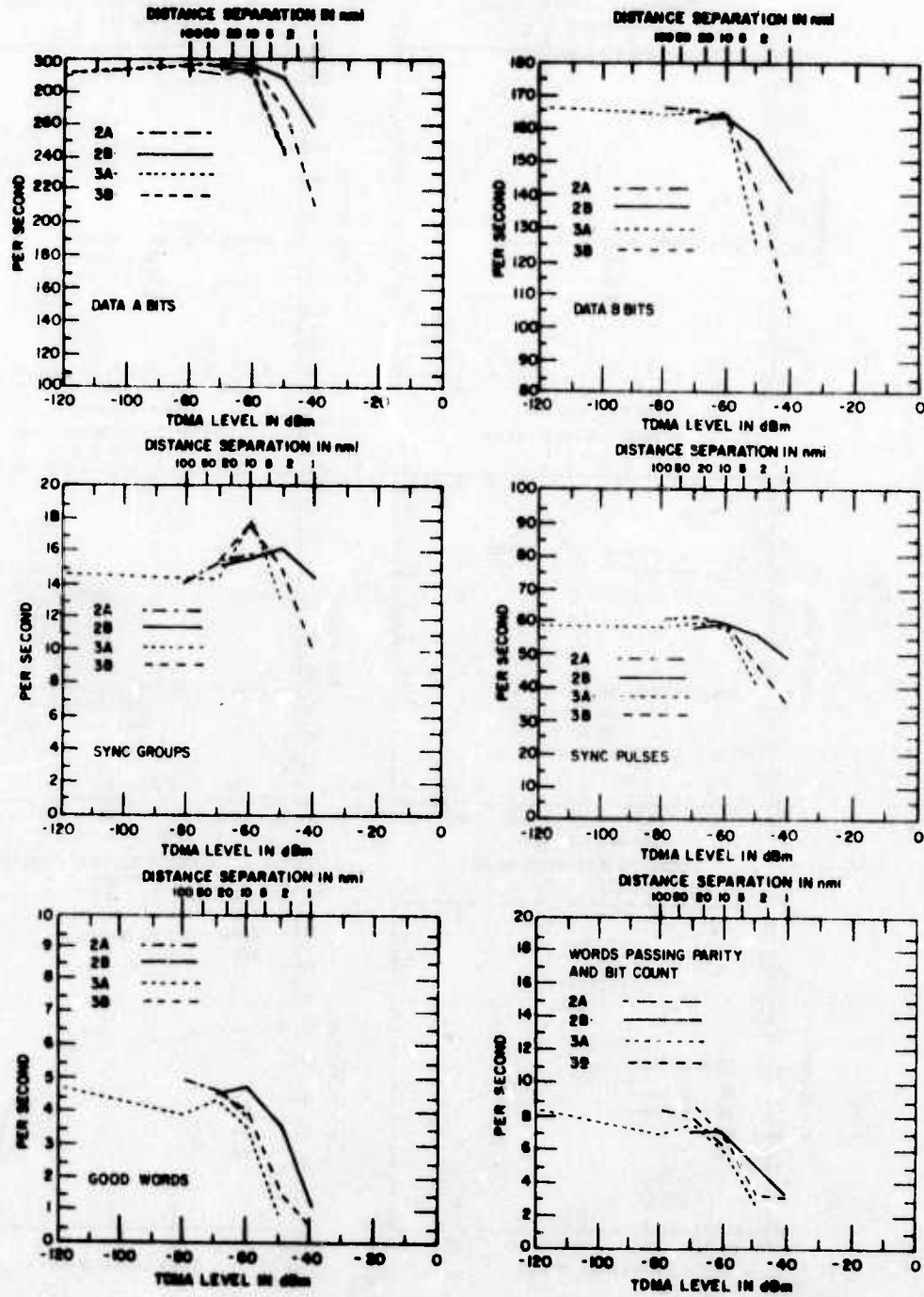

Figure 34. Digital data broadcast test results for desired signal level of MDS + 2 dB and wideband TDMA duty factor of 50%.

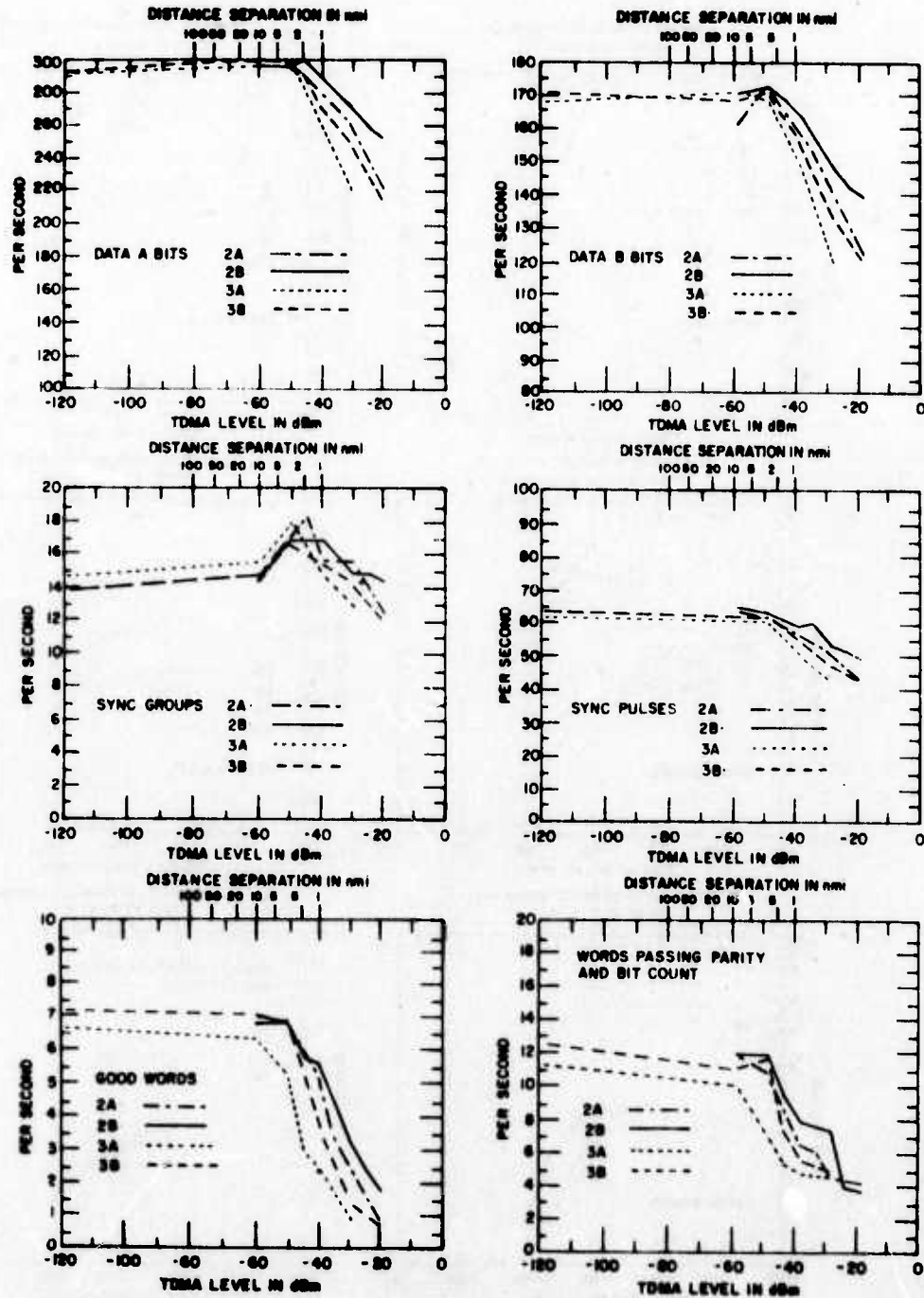

Figure 35. Digital data broadcast test results for desired signal level of MDS + 10 dB and wideband TDMA duty factor of 50%.

acquired	-	$\geq 4.5, \leq 7$ (7 was maximum good word count)
partially acquired	-	$\geq 2, < 4.5$
not acquired	-	$< 2$

If an error was noticed in the displayed station identification (ID) it was recorded in the comments. There was little correlation between an ID error and the parameters measured since ID errors occurred even when the interference was not affecting the Good Word count. Errors are permitted to be displayed if one of the two redundant words transmitted fails the parity or bit-count test and the other word experiences an error which does not affect the final bit count or parity.

#### IFF TRANSPONDER RESULTS

The IFF transponder test results are shown in APPENDIX F. The results indicated that no impact will occur between the TDMA terminal and the AN/APX-72 or the Collins 621A-6 or the GENAVE 4096 unless they are collocated aboard the same aircraft. The only problem discovered was with the Regency 505I, as indicated in Figure 36. For this case a distance separation of approximately 4 nmi is required to prevent any reduction in desired replies and to preclude spurious replies from any of the wideband TDMA waveforms. The results were similar for desired-signal levels of MDS and MDS + 3 dB and were independent of interrogation mode (3/A or C). Also, the results indicate that the spurious-reply count is linear with TDMA duty cycle. Due to the fact that no "AND" gate was used to count synchronous replies, the possible error in the approximation used prevented a similar conclusion from being drawn on the desired reply count.

For distance separations less than 4 nmi, the actual desired-reply count or spurious-reply count will depend upon the TDMA waveform selected, as is shown in the data.

Because of the dissimilarity in the performance of the Regency equipment as compared with the other transponders tested, the Regency's receiver bandpass characteristics were examined without TDMA interference present. This was done by off-tuning the interrogation frequency in the SQUAWK NAUT IFF interrogator simulator and determining the interrogation level necessary to produce a reply efficiency rate of 90%. The test indicated that the low-frequency response was down only 5 dB from the 1030 response, and that it was flat from 1025.5 to 1029 MHz. At 1031 MHz, more than 30 dB rejection was measured. The SQUAWK NAUT could not be detuned below 1025.5 MHz, and therefore, no lower frequency was examined. The apparently skewed response in the Regency could have defeated the 1030-MHz notch filter used in the TDMA simulator. No attempt was made to investigate the transponders that

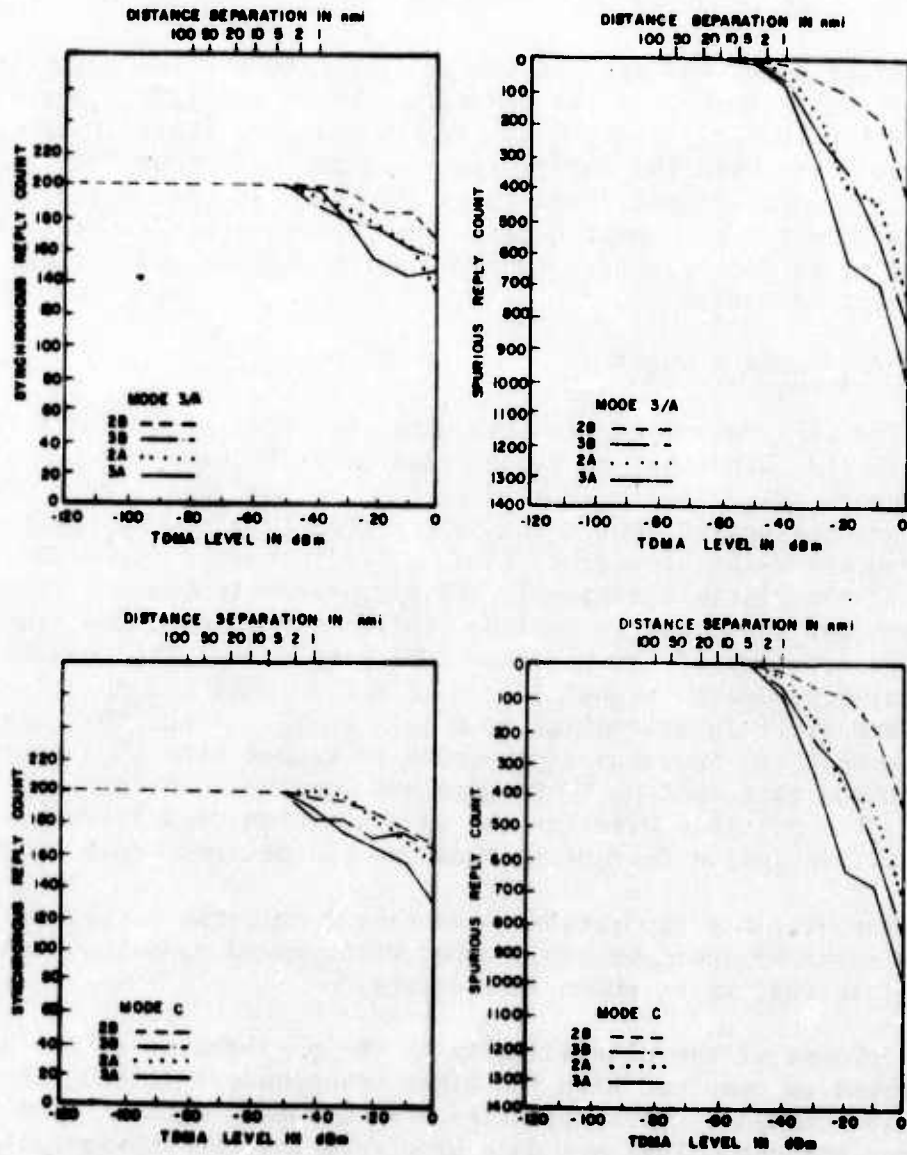

Figure 36. Regency 505I test results (desired signal - MDS + 3 dB, wideband TDMA duty cycle - 50%).

were not susceptible to the TDMA waveforms. Also, it is believed that standard check out procedures do not investigate IFF transponder bandpass characteristics. They are primarily concerned with the sensitivity of the receiver to a fixed 1030 MHz signal.

#### IFF INTERROGATOR TEST RESULTS

The test data taken on the ARTCBI-4 IFF interrogator is shown in APPENDIX G. The data plotted shows the synchronous reply count as a function of TDMA interference for desired signal levels of MDS + 1 dB and MDS + 3 dB, and TDMA duty cycles of 50% and 25%. Also, synchronous reply count is plotted as a function of desired-signal level and transponder reply code. Spurious reply count variation as a function of TDMA level is shown for 50% and 25% TDMA duty cycles. All of the data plotted is for the wideband TDMA mode of operation. The data taken on the TDMA narrowband mode of operation was not plotted because it had no measurable effect on the performance of the ARTCBI-4.

The distance scales in APPENDIX G have been slightly changed to incorporate the effect of the directional IFF interrogator antenna. Instead of having one scale to represent an omnidirectional gain, as was used in all other receivers tested, two distance scales were employed to represent the mainbeam and sidelobe interactions. The antenna gain values used in the calculations were taken from measured data on the FAA 8043 IFF interrogator antenna. The mainbeam gain was 23 dBi (3-degree horizontal beamwidth) and the average sidelobe gain was -11 dBi (36-degree horizontal sidelobe width). The two situations considered are when the interrogator antenna points at the TDMA terminal (mainbeam) and when it is  $\pm 18$  degrees off boresight (sidelobe). No consideration was given to the backlobe interaction, since it had a gain of only -21 dBi.

The synchronous-reply results for a desired-signal level of MDS + 3 dB and a TDMA duty factor of 50% are shown in Figure 37. The spurious-reply results for a 50% TDMA duty cycle are shown in Figure 38. The results are characterized by a break point, beyond which performance drops off rapidly with increasing TDMA level. It appears that a 10-nmi distance separation is required to prevent performance degradation to the ARTCBI-4 when the TDMA is in the mainbeam. The level of reply countdown and the number of spurious decodes for distance separations less than 10 nmi will depend on the particular TDMA waveform selected. In general the waveforms can be ranked from worst to best as 3A, 3B, 2A and 2B. The distance separation required for sidelobe interactions is less than 1 nmi for all waveforms.

The following summarizes the effect of the test parameters on the results.

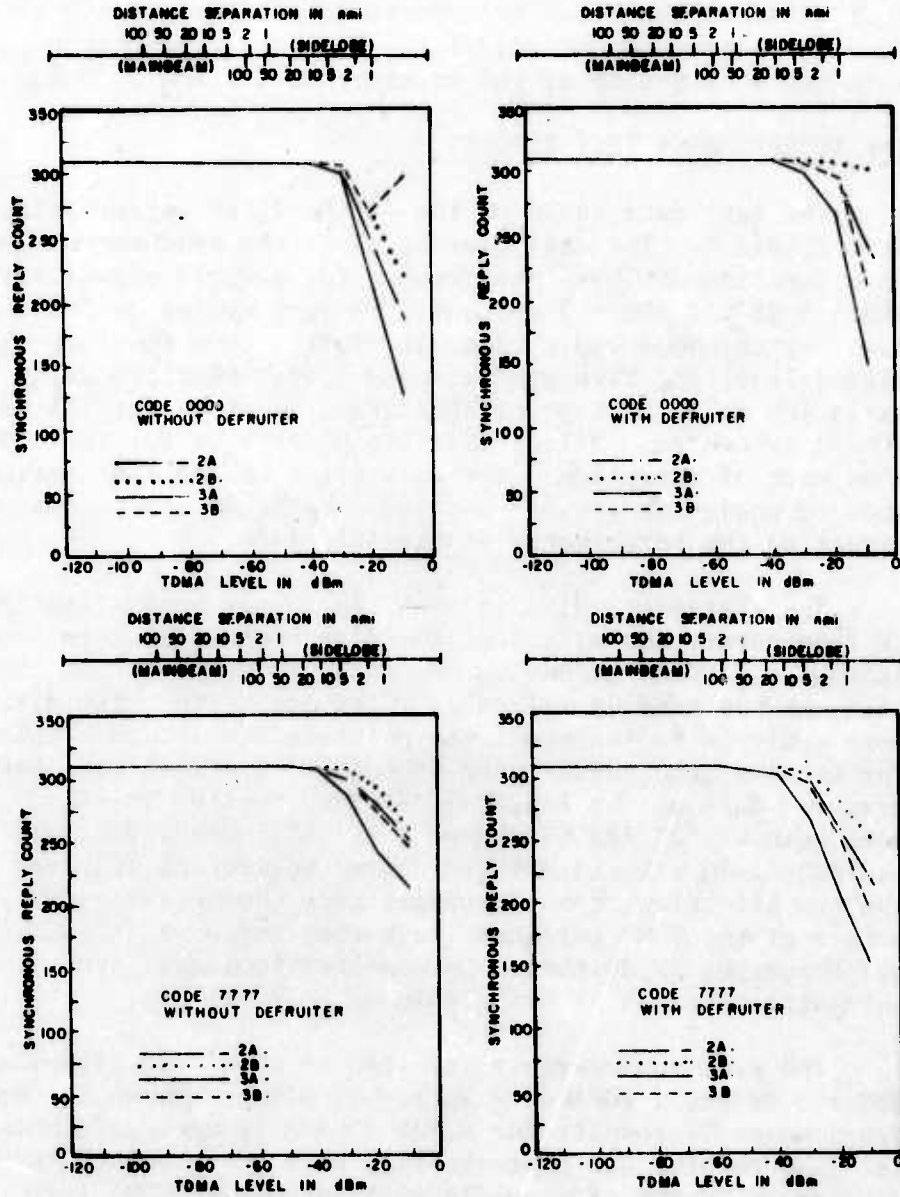

Figure 37. ARTCB1-4 synchronous reply count data for desired signal level of MDS + 3 dB and a wideband TDMA duty factor of 50%.

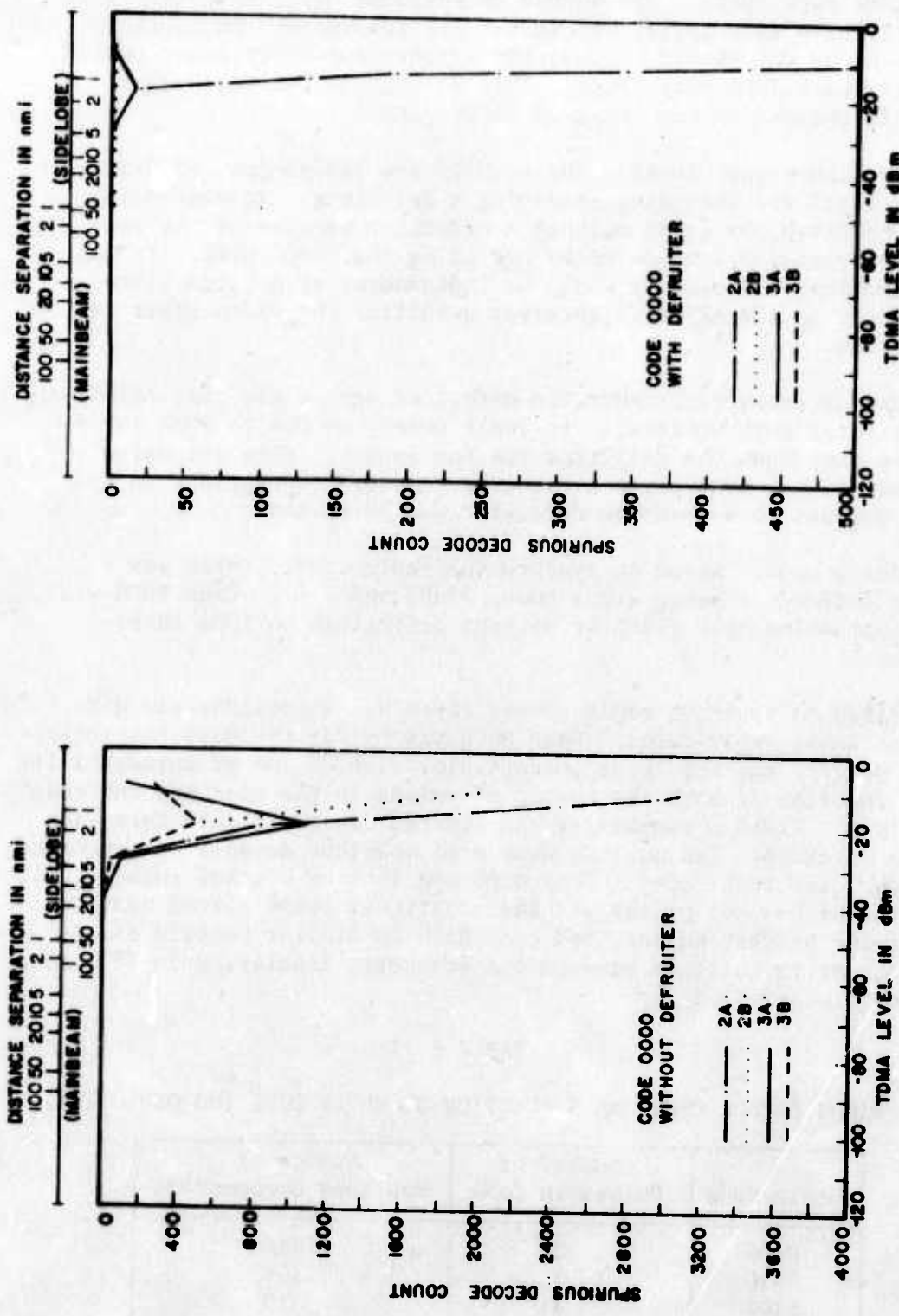

Figure 38. ARTCBI-4 spurious reply count data for wideband TDMA duty cycle of 50%.

*TDMA duty cycle.* The number of spurious decodes varies linearly with duty cycle. As in the IFF transponder test, it could not be determined whether the synchronous-reply count varies linearly with TDMA duty cycle. This was due to the measurement error introduced by not using an "AND" gate.

*Desired signal level.* The results are independent of desired signal level for the cases involving a defruiter. No conclusion could be drawn for cases without a defruiter because of the measurement variance introduced by not using the "AND" gate. It was expected that the results would be independent of desired-signal level because the ARTCBI-4 receiver quantizes the video prior to processing.

*Use of defruiter.* When the defruiter was in use, the ARTCBI-4 was slightly more vulnerable to reply countdown due to TDMA interference than when the defruiter was not in use. When the defruiter was not in use, however, the receiver was more susceptible to spurious decodes than when the defruiter was being used.

*Reply code.* Based on synchronous reply count, there was a slight difference among codes 0000, 7700, and 7777. Code 0000 was the least vulnerable (with or without defruiter) to TDMA interference.

Based on spurious-reply count, there was a considerable difference among reply codes. Code 0000 was by far the most susceptible and code 7777 was the least susceptible. The degree of vulnerability was a function of both the number of pulses in the code and the code positions. TABLE 6 summarizes the limited amount of data taken for the 3A waveform. The maximum number of spurious decodes was recorded for four different codes: Code 0000 consists of bracket pulses, 0010 consists of bracket pulses and one additional pulse placed next to one of the bracket pulses, and code 0100 is similar to 0010 except that the extra pulse is between the brackets; finally, code 7777 has all positions filled.

TABLE 6

SPURIOUS DECODE COUNT AS A FUNCTION OF REPLY CODE (NO DEFRUITER)

Reply Code	Number of Pulses in Code	Number of Spurious Decodes/Sec
0000	2	1044
0010	3	500
0100	4	20
7777	14	0

Video Photographs

In addition to the reply-count data, photographs were taken of the ARTCBI-4 raw and quantized video as the TDMA level was varied. These photos are contained in APPENDIX H. The major effect of the TDMA interference was to raise the noise level in the ARTCBI-4 receiver. In general, interference could barely be seen at a TDMA level of -50 dBm, which is consistent with the reply count data.

ARTCBI-3

The data taken on the ARTCBI-3 was limited to raw video photographs, also shown in APPENDIX H. A comparison of the photos of the ARTCBI-4 with those of the ARTCBI-3 indicates that the ARTCBI-3 is approximately 10 dB more vulnerable than the ARTCBI-4. The direct comparison of video photographs may not produce an accurate estimate of the vulnerability of the ARTCBI-3 receiver. However, it is believed that this approach will provide an upper bound on the susceptibility. Extension of the ARTCBI-4 results to the ARTCBI-3 requires that the distance separation curves be shifted 10 dB. This will increase the 10-nmi no-interference-separation requirement on the ARTCBI-4 to 30 nmi for the ARTCBI-3.

## SECTION 5

## RESULTS

INTRODUCTION

The test data were used to characterize a single JTIDS terminal transmitting with a power of a 1 kW and employing a duty cycle of 50%. This approximates single-net operation. It is pointed out that transmitter power and time-slot duty cycles are system variables that have not yet been firmly established. Since the duty cycle and transmitted power are crucial to the conclusions, adjustments to these results will be necessary when they are finally selected.

In general, the test results indicate that, from a compatibility standpoint, the JTIDS TDMA waveforms can be ranked, from worst to best, as 3A, 3B, 2A and 2B.

TACAN BEACON TESTS

Of the beacons tested, the AN/GRN-9C is the most susceptible to JTIDS interference. Assuming that a 5% reply-efficiency countdown is allowable, distance separations between the JTIDS terminal and the AN/GRN-9C on the order of 10 to 50 nmi may be required. However, assuming that a 70% reply efficiency criterion is acceptable, distance separations on the order of 2 to 20 nmi may be required. The distances are based on the desired-signal PRF that resulted in the greatest separation constraints. The actual distance separation required depends on the JTIDS waveform selected and the signal level of the desired signal.

Each of the other beacons tested require considerably less distance separation to satisfy the two separate compatibility criteria. A complete summary is provided in TABLE 5 (p. 63).

The results of the beacon loading tests indicate that little or no beacon loading is noticeable until the distance separation from the JTIDS terminal is less than 1 nautical mile.

TACAN/DME INTERROGATOR TESTS

The test results indicate that, of the DME's tested, the King KDM 7000 is the most susceptible to JTIDS interference. The interference affects the interrogator's ability to acquire lock. For a 70% reply efficiency and a 2700-pps reply rate, all measured results (except those for the MDS + 1 desired-signal level) lead to the following conclusions:

The required distance separation which would allow compatible operation between the JTIDS narrowband terminal and all of the airborne interrogators using common channels (17X to 126X) is less than 1 nautical mile. Military channels were not considered.

The required distance separation which would allow compatible operation between the JTIDS wideband terminal and all of the airborne interrogators tested except the KDM 7000 is also less than 1 nautical mile. With JTIDS operating in the wideband mode, the required distance separation of the KDM 7000 is a function of whether the DME is using X mode or Y mode, of the desired-signal level, and of the actual JTIDS waveform employed. For the Y mode of operation, the distance separation requirement is less than or equal to five nautical miles.

#### DIGITAL DATA BROADCAST TESTS

The performance criterion for the Digital Data Broadcast (DDB) results is assumed to be the location of the break point on the "Good Words" graph. The "Good Words" count is the best performance measure of the system as it is presently designed.

Based on this criterion, the distance separations required between a JTIDS terminal and an airborne DDB receiver operating with a MDS + 2 dB desired-signal level is 10 nmi and 2 nmi for wideband and simulated narrowband JTIDS operation, respectively. The results are linear with desired signal level. For a desired signal level of MDS + 10 dB the corresponding distance separations are 3 nmi and less than 1 nmi. Although the location of the break point was the same for all the waveforms tested, the effect of the waveforms differed as the JTIDS level was increased.

#### ATCRBS TRANSPONDER TESTS

The results indicate that no impact will occur between the JTIDS terminal and the AN/APX-72 or the Collins 621A-6, or the GENAVE 4096, unless they are collocated aboard the same aircraft. The only problem discovered was with the Regency 505I. For this case, a distance separation of approximately 4 nmi is required between the JTIDS terminal and the airborne transponder to prevent any reduction in desired replies and to preclude spurious replies from any of the wideband JTIDS waveforms. The results are similar for desired signal levels of MDS and MDS + 3 dB and are independent of interrogation mode (3/A or C).

For distance separations less than 4 nmi, the actual desired-reply count or spurious-reply count will depend upon the TDMA waveform selected.

ATCRBS INTERROGATOR TESTSARTCBI-4

The data taken on the ARTCBI-4 indicate that a 10-nautical-mile distance separation is required to prevent any performance degradation to the ATCRBS interrogator while the JTIDS terminal is in the mainbeam of its directional antenna. The amount of reply countdown and the number of spurious decodes for distance separations less than 10 nmi will depend on the particular TDMA waveform selected. The distance separation required for sidelobe antenna gain interactions is less than 1 nmi. The test results include the interference effects with and without a defruiter and with several transponder reply codes.

ARTCBI-3

The data on the ARTCBI-3 was limited to raw video photographs. Comparison of the photos on the ARTCBI-4 with those on the ARTCBI-3 indicates that the ARTCBI-3 is approximately 10 dB more vulnerable than the ARTCBI-4. It is pointed out that comparison of video photographs may not produce an accurate estimate of the vulnerability of the ARTCBI-3 receiver. To extend the ARTCBI-4 results to the ARTCBI-3 requires that the distance separation curves be shifted 10 dB. This will require a no-interference separation between JTIDS and the ARTCBI-3 of 30 nmi.

## APPENDIX A

## TEST EQUIPMENT SET-UP AND CALIBRATION

INTRODUCTION

This appendix describes the general test equipment used in the test and gives specific set-up instructions for the TDMA waveform simulator, the EPSCO TACAN beacon simulator, and the SQUAWK NAUT DME beacon/IFF interrogator simulator. Calibration procedures for each of the tests performed are also included.

GENERAL TEST EQUIPMENT

Calibration and maintenance of the general test equipment was the responsibility of the government agency (either FAA or NESTEF) or the private company (Hughes Aircraft Co.) that provided the equipment. TABLE A-1 indicates the test equipment used and the respective donor.

TDMA WAVEFORM SIMULATOR, TEST SET-UP CALIBRATION PROCEDURE

The pre-programmed frequencies used for the JTIDS system were 965 to 1010 MHz, 1050 to 1070 MHz and 1110 to 1209 MHz. The basic TDMA waveform settings are shown in TABLE A-2. The simulator was capable of being programmed so that any number of the possible frequencies could be utilized. This was useful whenever it was necessary to deviate from the standard pre-programmed frequencies such as the TACAN beacon testing (in order to achieve worst case frequency densities) and in the DDB testing (to simulate a TDMA narrowband mode of operation).

CALIBRATION

The basic test set-up is shown in Figure A-1. It shows the TDMA waveform simulator connected to the RF coupling network consisting of directional couplers, step attenuators, an isolator and for narrowband operation a narrowband filter. The RF coupling network is connected to the input port of a hybrid. For the purposes of the TDMA waveform simulator set-up calibration procedure the other input port to the hybrid may be terminated with a 50 ohm load, however, this port was normally connected to a desired signal source for the unit being tested.

Before proceeding with the calibration procedure, the TDMA waveform simulator was set with the standard settings given in TABLE A-2. If a desired signal generator was connected to the input port of the hybrid, its output power level was set to a minimum. The

**TABLE A-1**  
**CALIBRATION AND MAINTENANCE OF THE GENERAL PURPOSE**  
**TEST EQUIPMENT**

<u>Equipment provided by Hughes Aircraft Co.</u>	<u>Equipment provided by the FAA</u>
1. TDMA Waveform Simulator	1. Spectrum Analyzer RF Section HP8555A IF Section HP8552B Display Section 141T RF Section HP8554B
2. PM - Md. 1018 Peak Power Meter	2. RF Power Meter - HP-432
3. RF Coupling Network which included step attenuators, directional couplers, an isolator, and a hybrid	3. Variable attenuator - NARDA
4. 50 $\Omega$ terminations	4. Various fixed attenuators
<u>Equipment provided by NESTEF</u>	5. PIN Diode Modulator HP8403A
1. EPSCO TACAN Beacon Simulator	6. Various Counters/Timers including: 3 - HP5245M one with TACAN Band RF converter 5254A Systron Donner 6150 and 6153 HP5300A/5302A
	7. Various oscilloscopes used at each of the test sites.
	8. RF Signal Generator HP612A
	9. Sierra Test Set Serial #002 Modified to perform like 7124-0160-5.
	10. SQUAWK NAUT.

TABLE A-2

BASIC TDMA WAVEFORM SIMULATOR SETTINGS

Function	Setting
1. Preamble - number of chips on number of chips off number of segments	As required As required As required
2. Data - number of chips on number of chips off number of segments	As required As required As required
3. Chip rate (PN rate in megabits)	As required
4. $F_1F_2/F_1F_2F_3$ switch (used to inhibit second or second and third adjacent frequency selected from falling within a specified $\Delta f$ )	$F_1F_2$
5. F step switch, used to set frequency separation between possible tones	As required
6. Slot start (fixed or variable)	Fixed
7. PN data on/off (in the off position, CW is transmitted)	As required
8. Code (three possible frequency selection codes were available)	1
9. PRF (on/CW) on is normal, CW eliminates off gate (continuous transmission)	on
10. Test/OPR	OPR
11. Enable/inhibit	N/A
12. Restricted hop (minimum $\Delta f$ used in $F_1F_2/F_1F_2F_3$ )	As required
13. Frequency select	N/A
14. Memory load	Depress
15. Reset	Depress
16. Mode (1 is wideband mode, 2-4 is narrowband mode)	As required
17. Duty cycle	As required
18. Range	Normal
19. Power adjust attenuators	As required

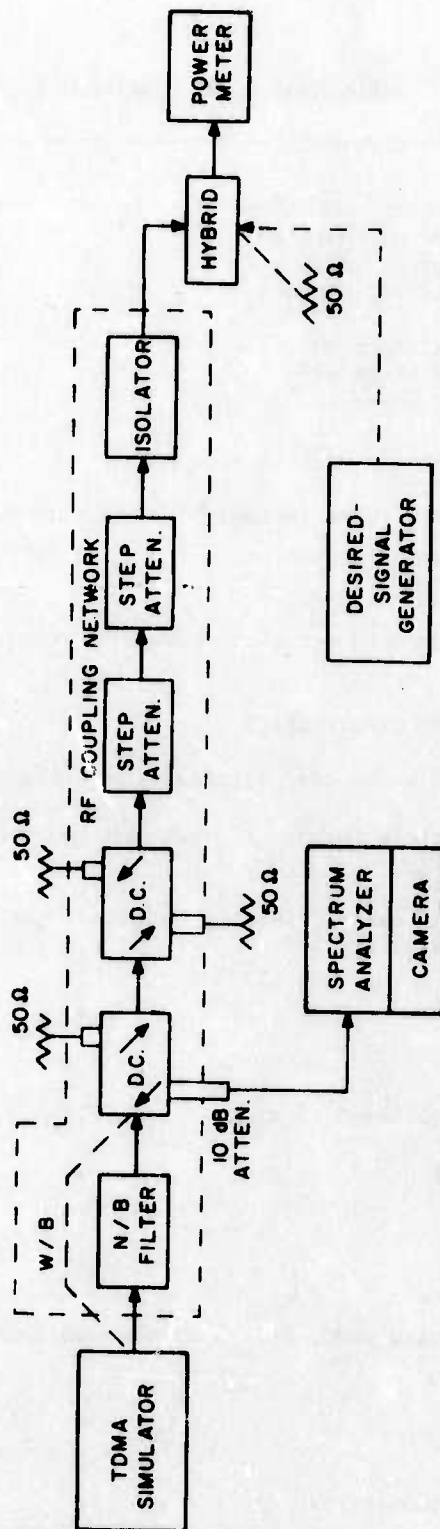

Figure A-1. TDMA waveform simulator test setup.

FREQ SEL SWITCH was set to the test frequency to be checked. The OPER - TEST switch was set to TEST, and the PRF was set to CW. The RF power meter connected to the output of the hybrid was zeroed and the RF coupling network attenuators were set to 0 dB attenuation. The RF power meter indicates the level desired for the particular unit being tested.

There were two levels to which the output power level was adjusted. When testing the TACAN/DME interrogators, the SSR transponders, and the DDB, 0 dBm was set. For all other equipments that were tested +20 dBm was set. The +20 dBm either compensated for or partially compensated for losses in the input directional couplers on the units being tested, allowing a maximum interference power as close to 0 dBm as possible.

To obtain the desired output power level the attenuators on the front of the TDMA waveform simulator were adjusted. In general, an output of 0 dBm corresponded to an attenuator setting of 22 dB, while an output of + 20 dBm corresponded to an attenuator setting of 2 dB.

The TDMA waveform simulator RF output power level was checked after each new equipment set-up and/or several times per day. In general, the TDMA waveform simulator power output was very stable and required very little monitoring.

Visual inspection of the TDMA output spectrum in the simulator's various modes of operation was also done. The spectrum was continuously monitored during the testing to ensure proper operation of the TDMA waveform simulator. At the end of the testing, pictures of the TDMA waveform simulator were taken with the simulator operating in each of its modes. These are shown in Figures 9 through 15.

#### EPSCO Beacon Simulator Test Set-up Calibration Procedure

The beacon simulator set-up is shown in Figure A-2. The set-up shows a peak power meter connected to the output of the hybrid. An oscilloscope is also shown connected into the test set-up. It is connected so that a detected beacon simulator output waveform is displayed. An intensified region indicating the region sampled by the peak power meter is also displayed. In this set-up the intensified region and hence the sample point for the peak power may be changed by adjusting the scope trigger delay. This was adjusted to the peak of the second pulse. However, the test conductors found that the same results could be obtained without the scope using the peak power meter's internal trigger and delay mechanism. Throughout most of the testing the use of the scope was deleted.

The procedure involved setting the beacon simulator to the standard settings shown in TABLE A-3 and setting the TDMA RF coupling

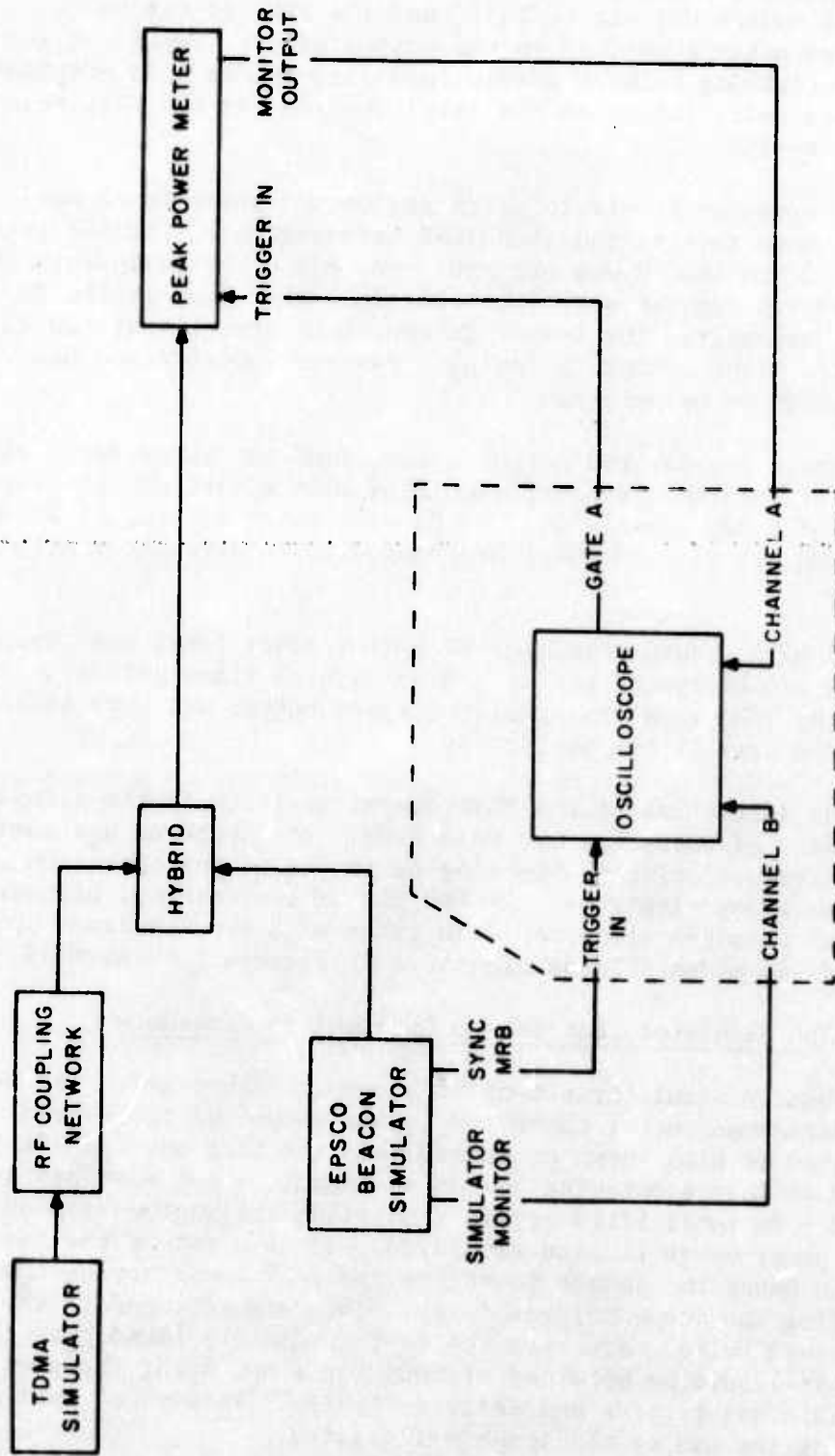

Figure A-2. Setup to monitor the beacon simulator.

network attenuators to 120 dB. The proper beacon channel is set on the EPSCO and the power level is set to 0 dBm. The trigger delay adjustment on the scope is then adjusted so that the intensified portion is at the top of the waveform displayed or if no scope is used the internal trigger delay is adjusted for a maximum display reading (approximately 12  $\mu$ s for X mode and 30  $\mu$ s for Y mode on the trigger delay). The power level is now read from the peak power meter display. This power level is used to correct the power level displayed on the beacon simulator. This corrects for losses in the hybrid and associated plumbing and for inaccuracy in the beacon simulator displayed power. Because the beacon simulator output power varied considerably from time to time, the output power was monitored several times before and during each test.

TABLE A-3

## TACAN BEACON SIMULATOR (EPSCO TS-3244) SETTINGS

- |   |
|---|
| 1. System Mode: X or Y                                      |
| 2. Simulator Mode: Random                                   |
| 3. Bearing: 90°   |
| 4. Range: 18 miles  |
| 5. 15 Hz Modulation: 30%                                    |
| 6. 135 Hz Modulation: 30%                                   |
| 7. Relative Phase Shift: 0°                                 |
| 8. Squitter Rate: 2700 (variable)                           |
| 9. Reply Efficiency: 70% (variable)                         |
| 10. Pulse Spacing: 12 $\mu$ s (X mode), 30 $\mu$ s (Y mode) |
| 11. RF Power Level: variable                                |
| 12. TACAN Channel: set as test dictates                     |

SQUAWK NAUT SSR Interrogator Simulator Test Set-up Calibration

The calibration set-up for the SQUAWK NAUT is shown in Figure A-3. Initially the SQUAWK NAUT parameters were set according to the standard settings given in TABLE A-4 and the TDMA RF coupling attenuators were set to 120 dB. The SQUAWK NAUT output attenuator was set for 0 dBm. The output power level was measured using the peak power meter adjusted for the peak of either the  $P_1$  or  $P_3$  pulse. The value obtained was used as a correction factor for the attenuator setting on the SQUAWK NAUT to obtain the actual power level used in the testing. The SQUAWK NAUT output power was stable but was monitored before and after each test.

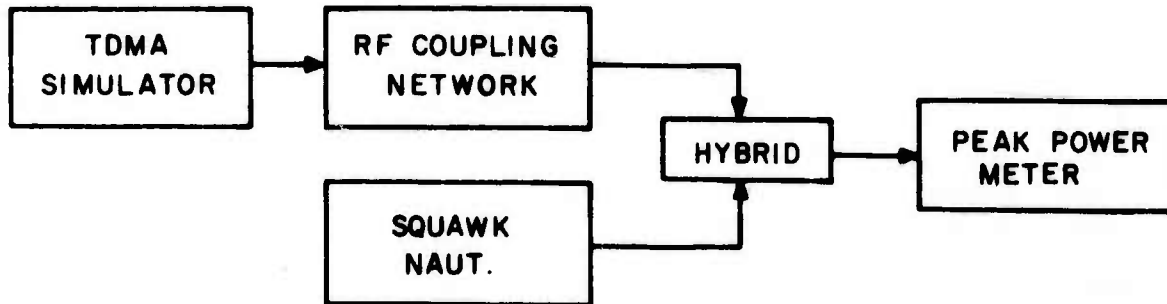

Figure A-3. Setup to check the SQUAWK NAUT calibration.

TABLE A-4

SSR INTERROGATOR SIMULATOR (SQUAWK NAUT) SETTINGS

- |   |
|---|
| <ol style="list-style-type: none"> <li>1. Function Switch → ATC</li> <li>2. Mode Switch → 3A/3C</li> <li>3. Pulse Width → .8 μsec</li> <li>4. P<sub>2</sub> Deviation → 0</li> <li>5. P<sub>2</sub> - P<sub>3</sub> Deviation → 0</li> <li>6. P<sub>2</sub> Suppression → 10 dB</li> <li>7. Echo Injection Suppression → off</li> <li>8. Δf → 0</li> <li>9. Output RF Level → variable</li> </ol> |
|---|

Digital Data Broadcast Test Set-up Calibration

Figure A-4 shows the test set-up for the calibration of the received TACAN signal at the output port of the hybrid. The standard settings as shown in TABLE A-2 are set on the EPSCO beacon simulator and the TDMA RF coupling attenuators are set to 120 dB. The beacon simulator and the Sierra Test Set were set for channel 27X which corresponded to the RTB-2 TACAN beacon channel. The variable attenuator was set to its minimum attenuation. The AGC voltage after the Sierra Test Set had acquired the beacon signal was noted. The hybrid was then disconnected from the Sierra Test Set and the EPSCO beacon simulator was connected to the Sierra Test Set. The output power level on the EPSCO beacon simulator which was calibrated using the peak power meter was adjusted to obtain the same AGC voltage previously noted. The power available from the antenna was the beacon simulator power level displayed plus a correction factor for the EPSCO beacon simulator power level. By using the variable attenuator any desired signal level up to the calibrated value could be obtained.

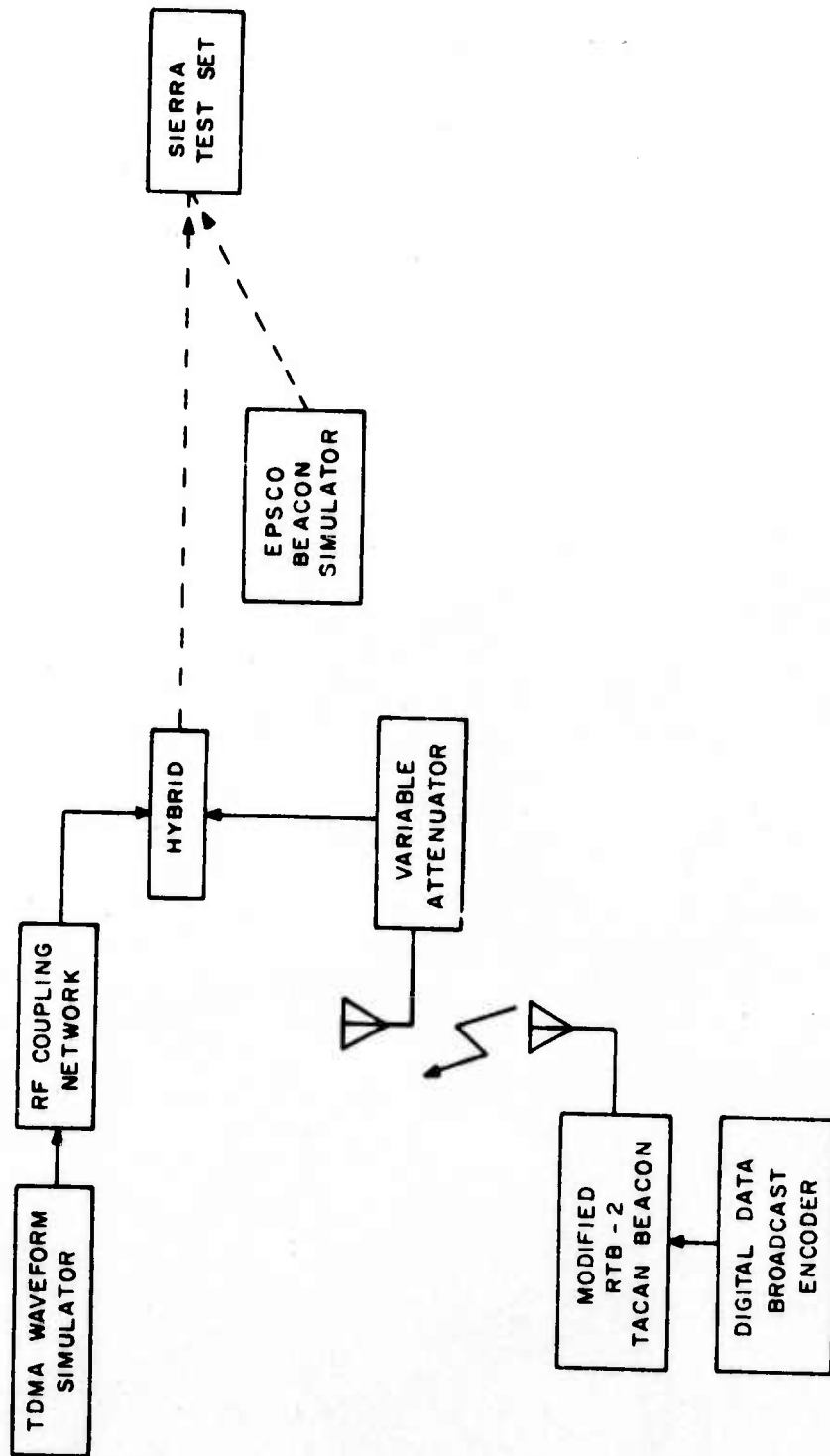

Figure A-4. Digital data broadcast test setup for calibration.

APPENDIX B

TACAN BEACON REPLY EFFICIENCY RESULTS

CONTENTS

<u>Figure</u>	<u>Page</u>
B-1 AN/GRN-9C beacon reply efficiency results for TDMA duty factor of 50% . . . . .	101
B-2 AN/GRN-9C beacon change in reply efficiency results for TDMA duty factor of 50% . . . . .	102
B-3 AN/GRN-9C beacon reply efficiency results for TDMA duty factor of 25% . . . . .	103
B-4 AN/GRN-9C beacon change in reply efficiency results for TDMA duty factor of 25% . . . . .	104
B-5 AN/GRN-9C beacon reply efficiency results for TDMA duty factor of 10% . . . . .	105
B-6 AN/GRN-9C beacon change in reply efficiency results for TDMA duty factor of 10% . . . . .	106
B-7 RTB-2 beacon reply efficiency results for TDMA duty factor of 50% . . . . .	107
B-8 RTB-2 beacon change in reply efficiency results for TDMA duty factor of 50% . . . . .	108
B-9 RTB-2 beacon reply efficiency results for TDMA duty factor of 25% . . . . .	109
B-10 RTB-2 beacon change in reply efficiency results for TDMA duty factor of 25% . . . . .	110
B-11 RTB-2 beacon reply efficiency results for TDMA duty factor of 10% . . . . .	111
B-12 RTB-2 beacon change in reply efficiency results for TDMA duty factor of 10% . . . . .	112
B-13 Modified RTB-2 X mode beacon reply efficiency results for TDMA duty factor of 50% . . . . .	113
B-14 Modified RTB-2 X mode beacon change in reply efficiency results for TDMA duty factor of 50% . . . . .	114
B-15 Modified RTB-2 X mode beacon reply efficiency results for TDMA duty factor of 25% . . . . .	115
B-16 Modified RTB-2 X mode beacon change in reply efficiency results for TDMA duty factor of 25% . . . . .	116
B-17 Modified RTB-2 X mode beacon reply efficiency results for TDMA duty factor of 10% . . . . .	117
B-18 Modified RTB-2 X mode beacon change in reply efficiency results for TDMA duty factor of 10% . . . . .	118
B-19 Modified RTB-2 Y mode beacon reply efficiency results for TDMA duty factor of 50% . . . . .	119
B-20 Modified RTB-2 Y mode beacon change in reply efficiency results for TDMA duty factor of 50% . . . . .	120

APPENDIX B

TACAN BEACON REPLY EFFICIENCY RESULTS

CONTENTS (Cont'd)

<u>Figure</u>	<u>Page</u>
B-21 Modified RTB-2 Y mode beacon reply efficiency results for TDMA duty factor of 25% . . . . .	121
B-22 Modified RTB-2 Y mode beacon change in reply efficiency results for TDMA duty factor of 25% . . . . .	122
B-23 Modified RTB-2 Y mode beacon reply efficiency results for TDMA duty factor of 10% . . . . .	123
B-24 Modified RTB-2 Y mode beacon change in reply efficiency results for TDMA duty factor of 10% . . . . .	124
B-25 Butler DME beacon reply efficiency results for TDMA duty factor of 50% . . . . .	125
B-26 Butler DME beacon change in reply efficiency results for TDMA duty factor of 50% . . . . .	126
B-27 Butler DME beacon reply efficiency results for TDMA duty factor of 25% . . . . .	127
B-28 Butler DME beacon change in reply efficiency results for TDMA duty factor of 25% . . . . .	128

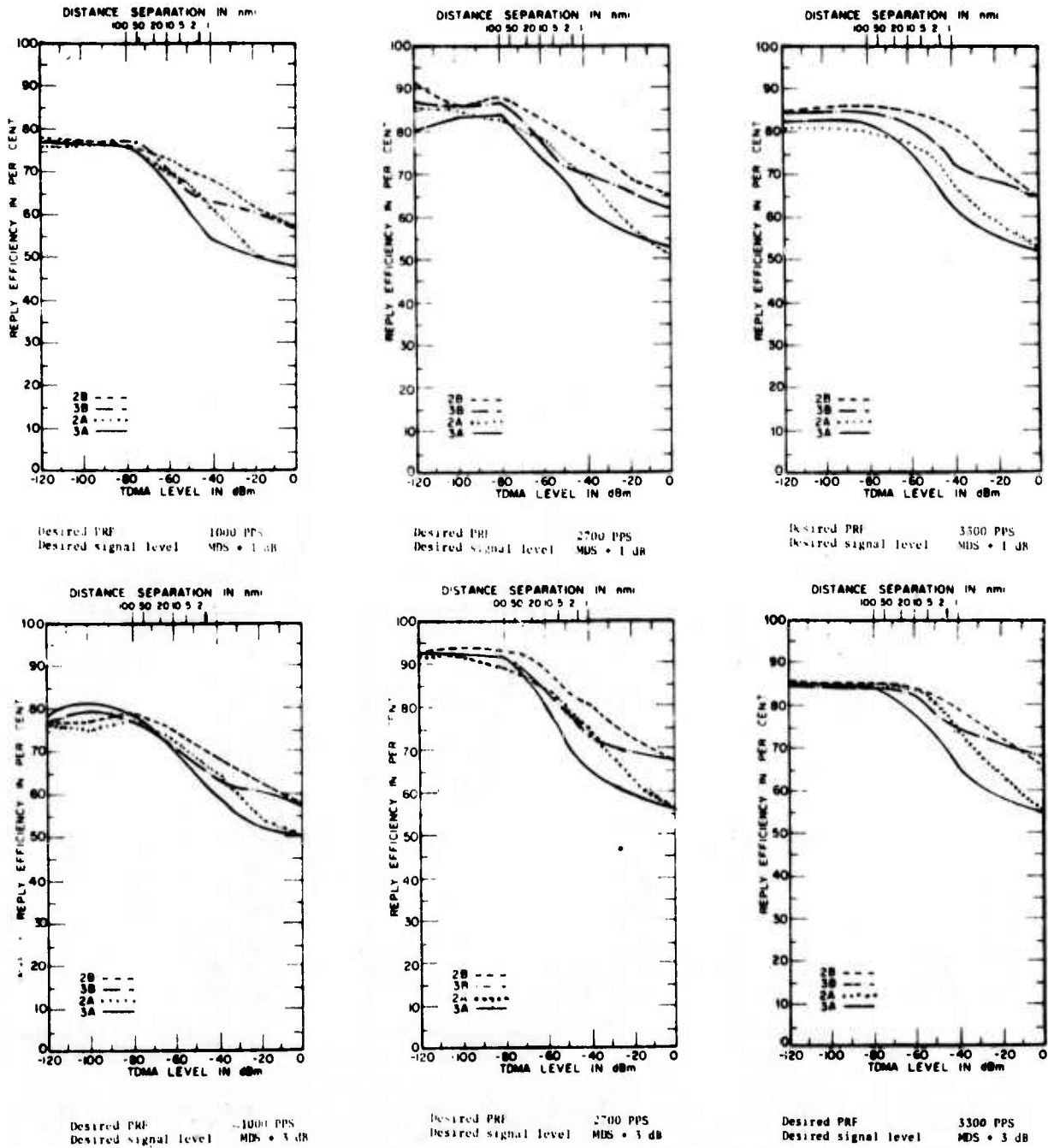

Figure B-1. AN/GRN-9C beacon reply efficiency results for TDMA duty factor of 50%.

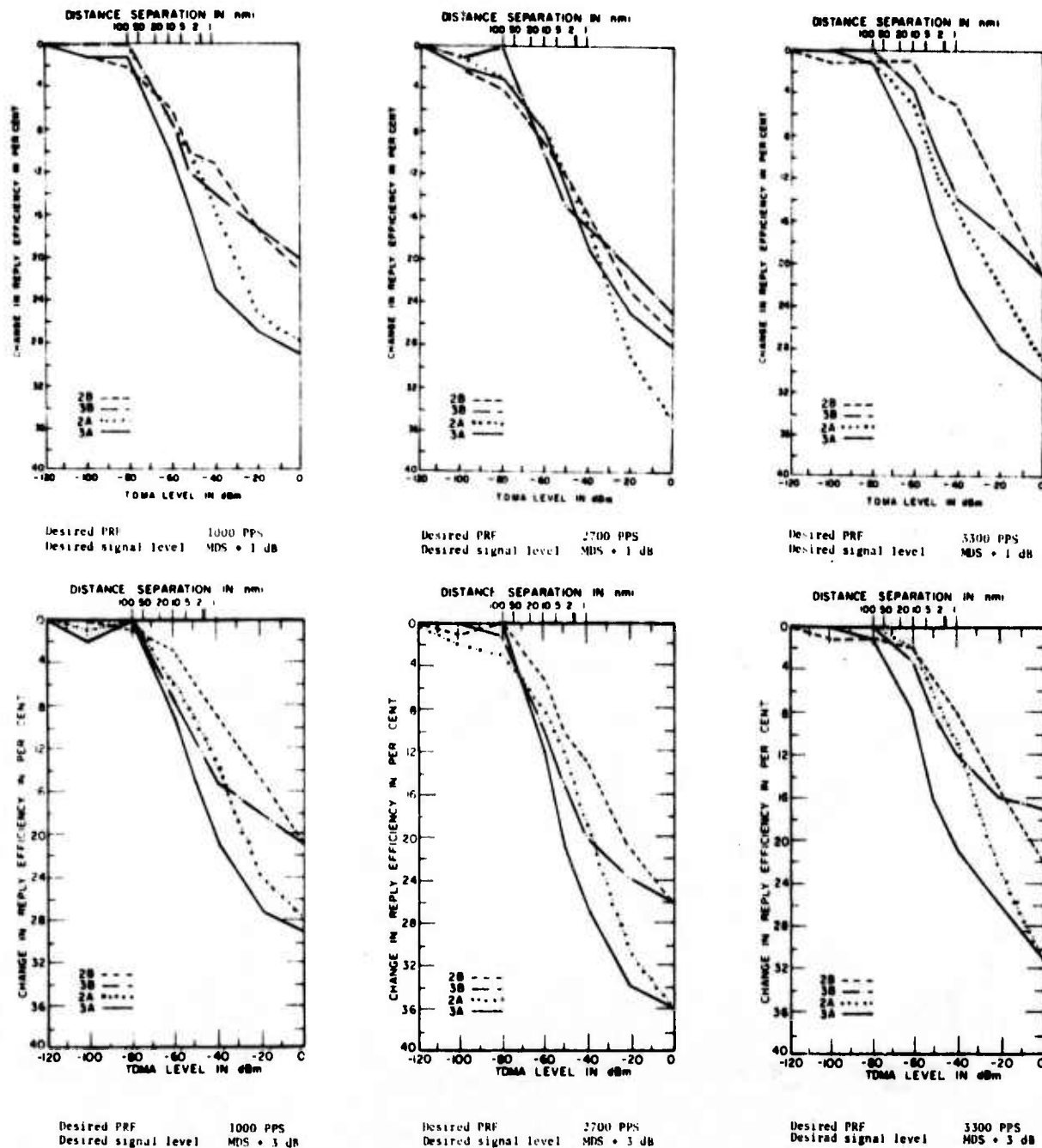

Figure B-2. AN/GRN-9C beacon change in reply efficiency results for TDMA duty factor of 50%.

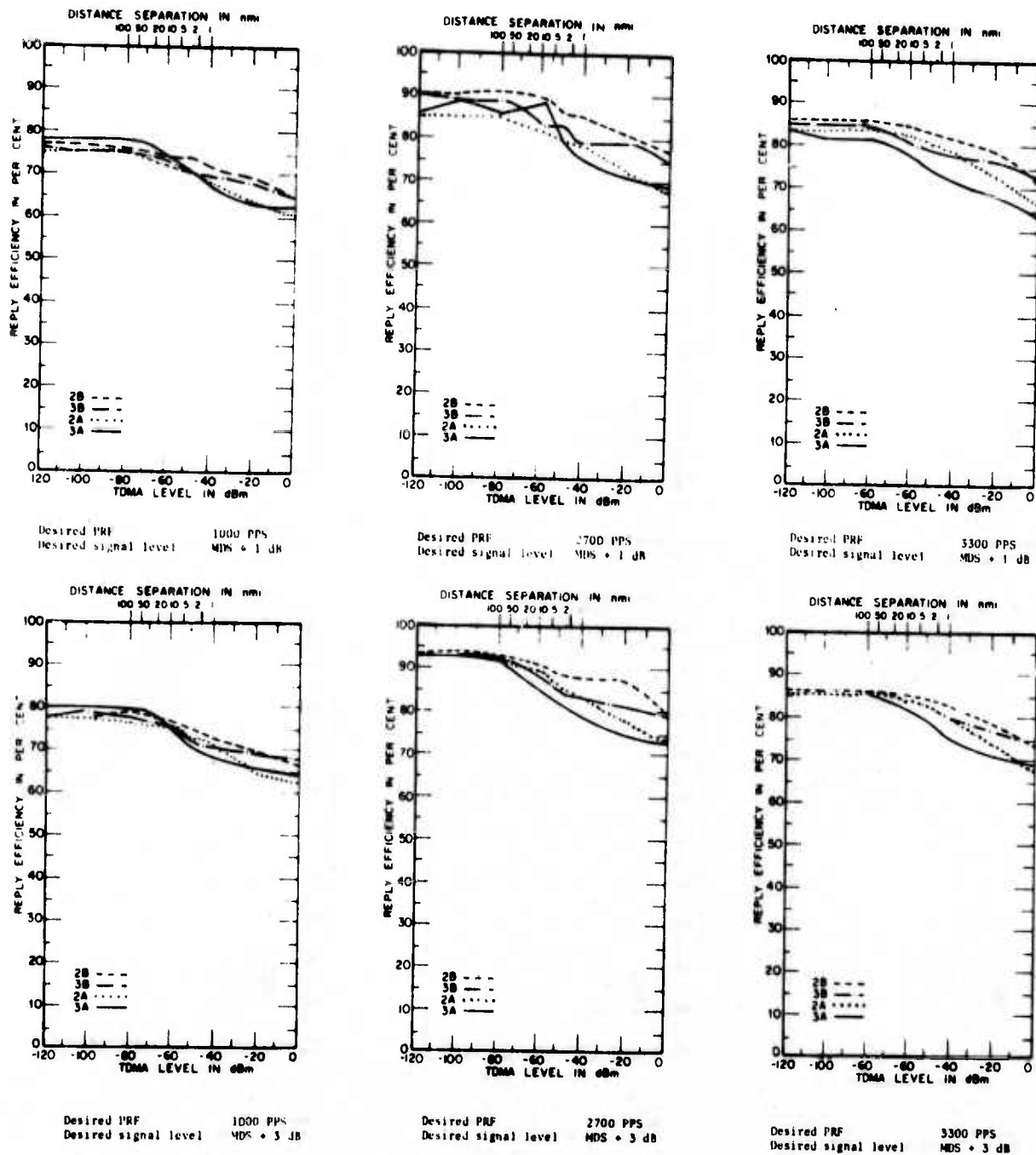

Figure B-3. AN/GRN-9C beacon reply efficiency results for TDMA duty factor of 25%.

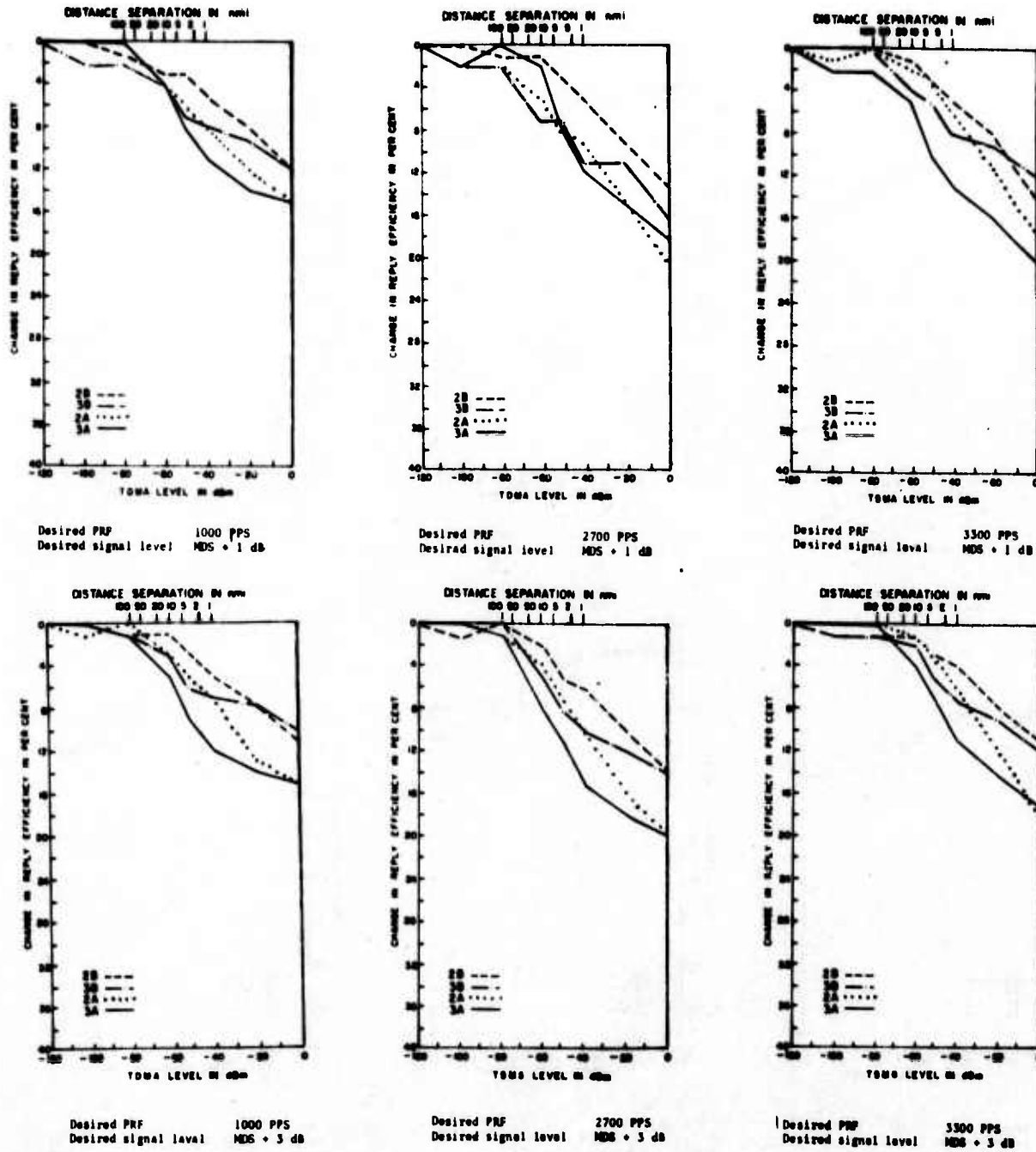

Figure B-4. AN/GRN-9C beacon change in reply efficiency results for TDMA duty factor of 25%.

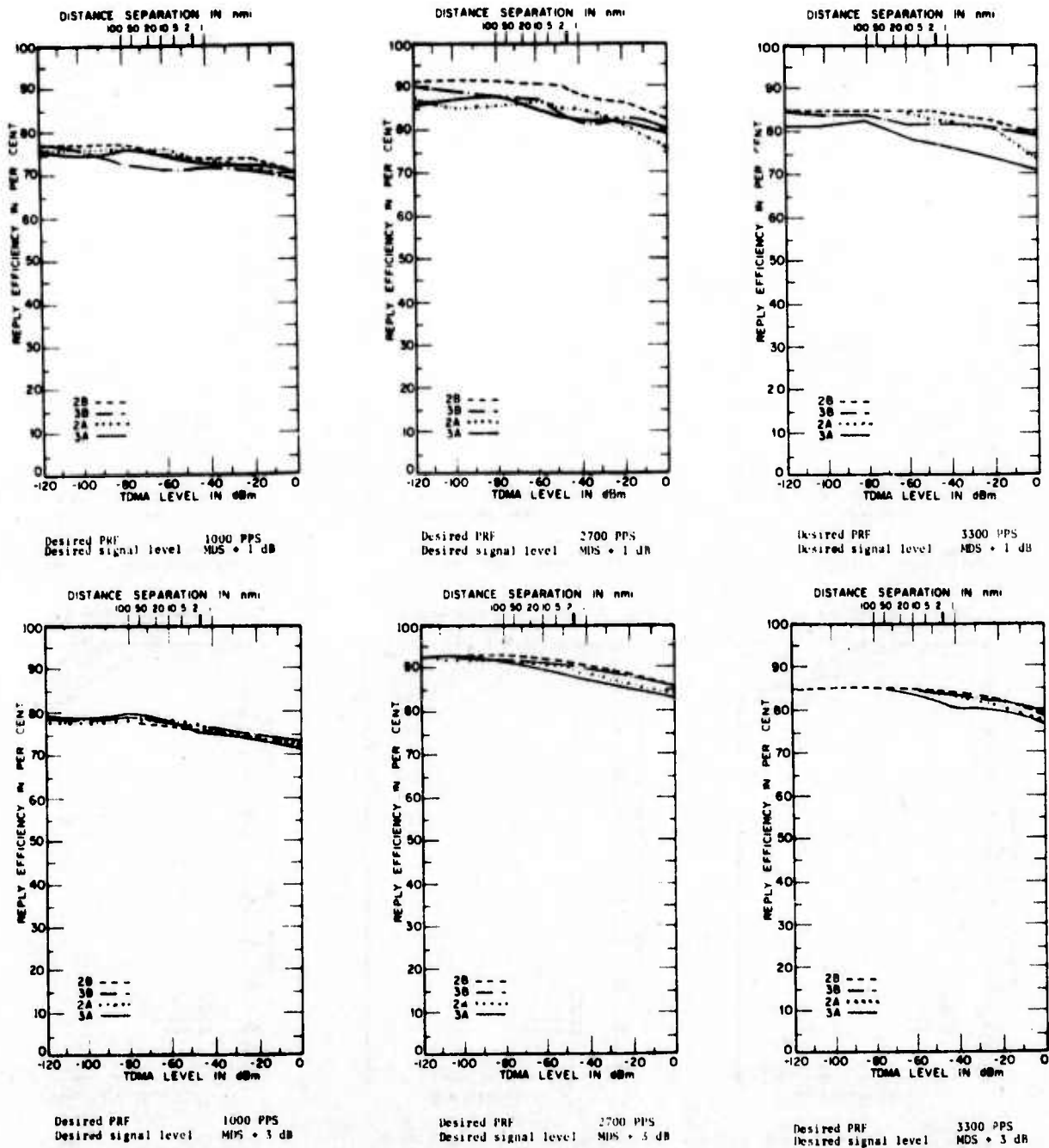

Figure B-5. AN/GRN-9C beacon reply efficiency results for TDMA duty factor of 10%.

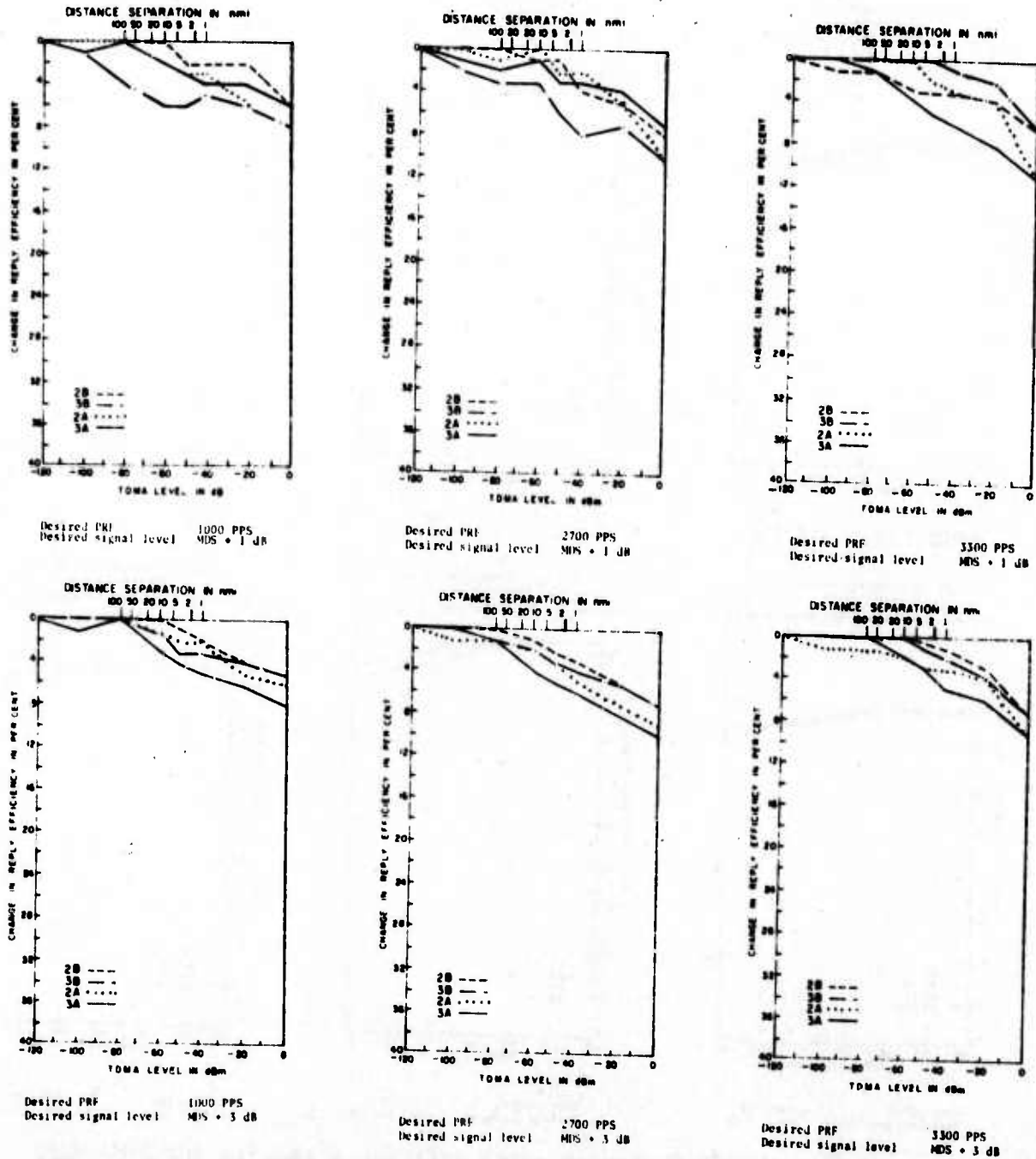

Figure B-6. AN/GRN-9C beacon change in reply efficiency results for TDMA duty factor of 10%.

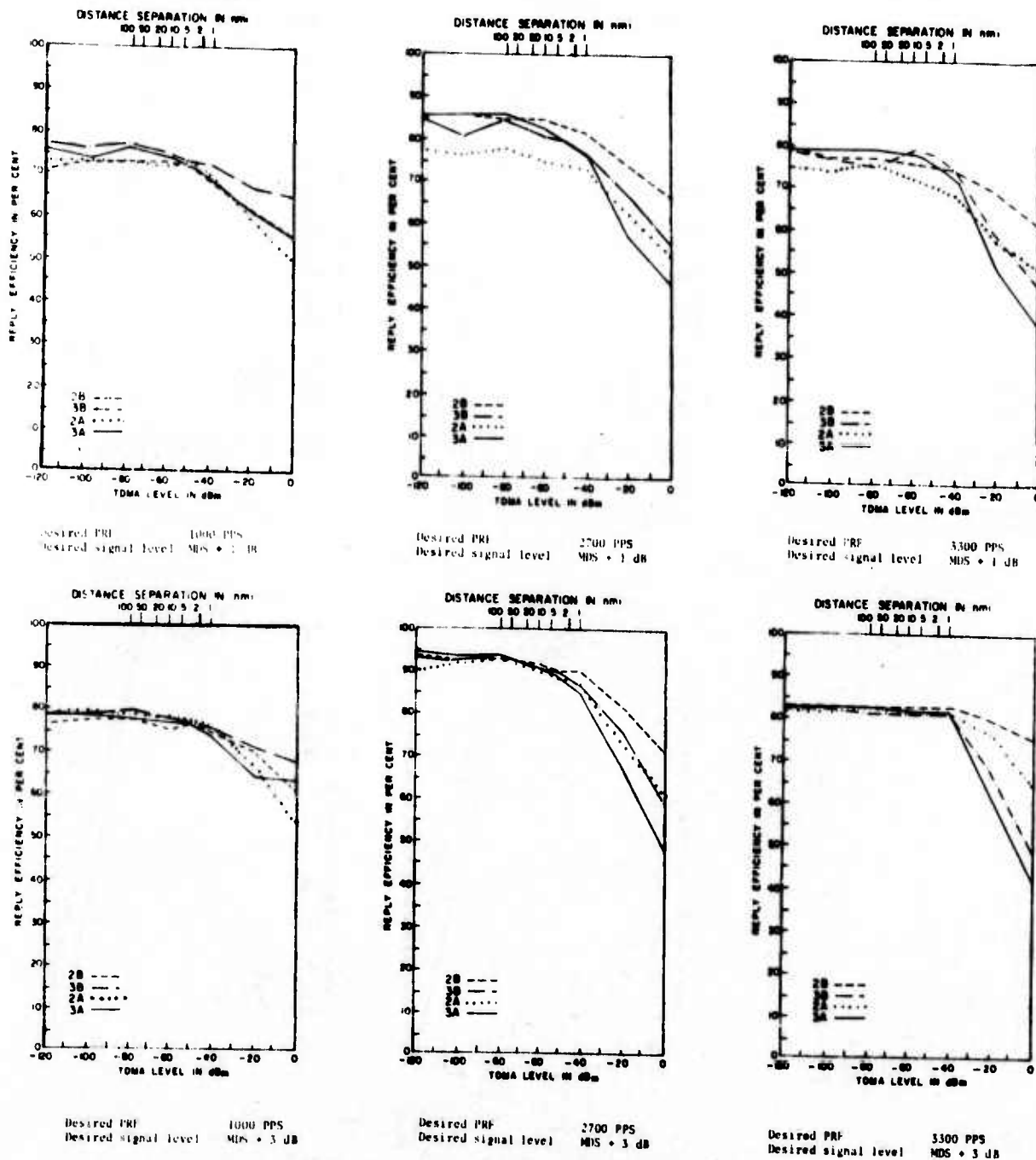

Figure B-7. RTB-2 beacon reply efficiency results for TDMA duty factor of 50%.

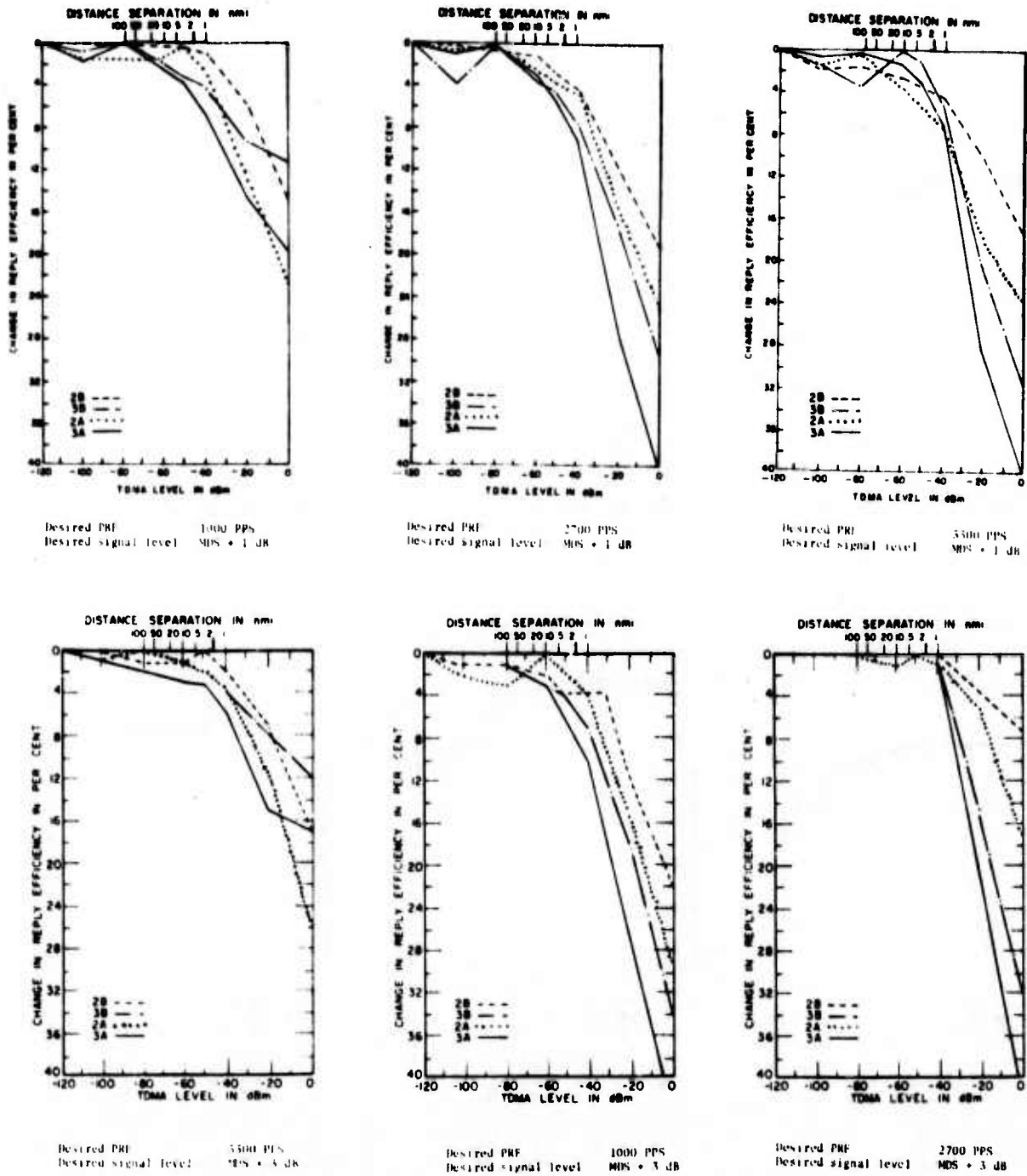
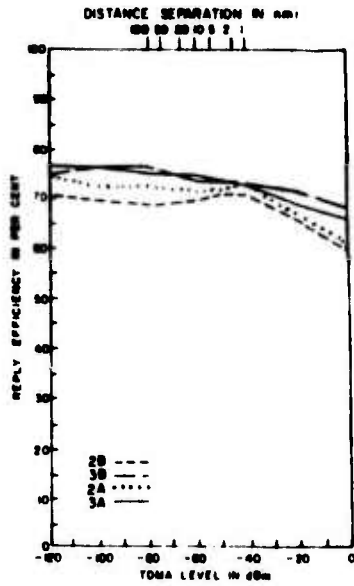
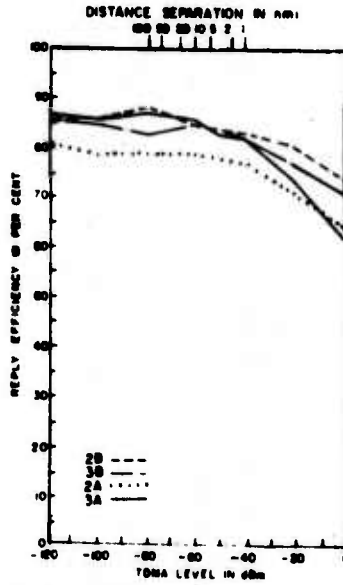

Figure B-8. RTB-2 beacon change in reply efficiency results for TDMA duty factor of 50%.



Desired PRI 1000 PPS  
Desired signal level MIS + 1 dB



Desired PRI 2700 PPS  
Desired signal level MIS + 1 dB

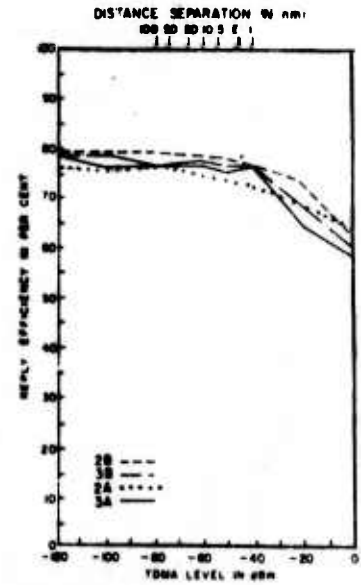

Desired PRI 5500 PPS  
Desired signal level MIS + 1 dB

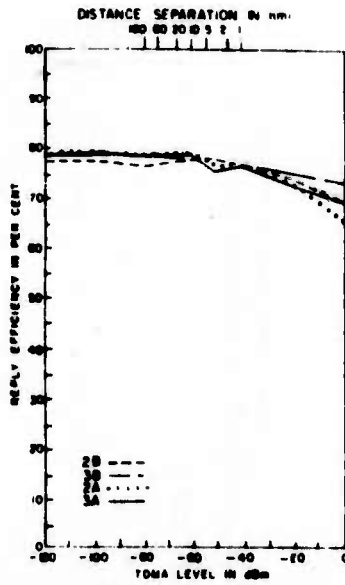

Desired PRI 1000 PPS  
Desired signal level MIS + 3 dB

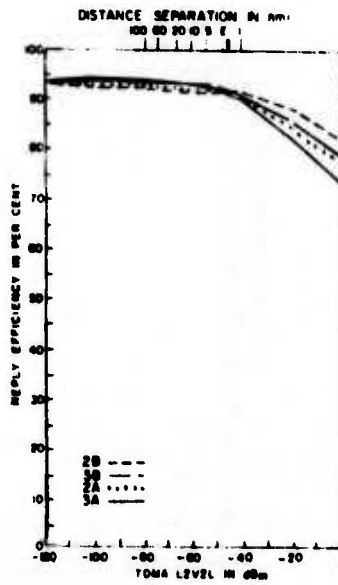

Desired PRI 2700 PPS  
Desired signal level MIS + 3 dB

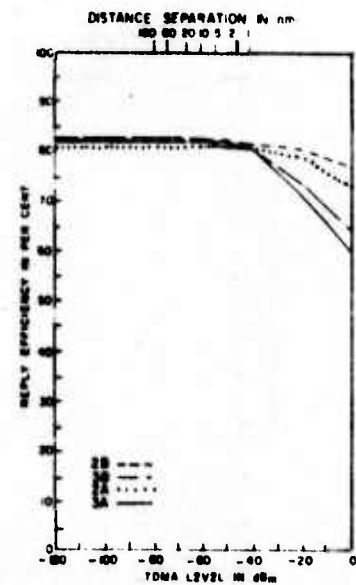

Desired PRI 5500 PPS  
Desired signal level MIS + 3 dB

Figure B-9. RTB-2 beacon reply efficiency results for TDMA duty factor of 25%.

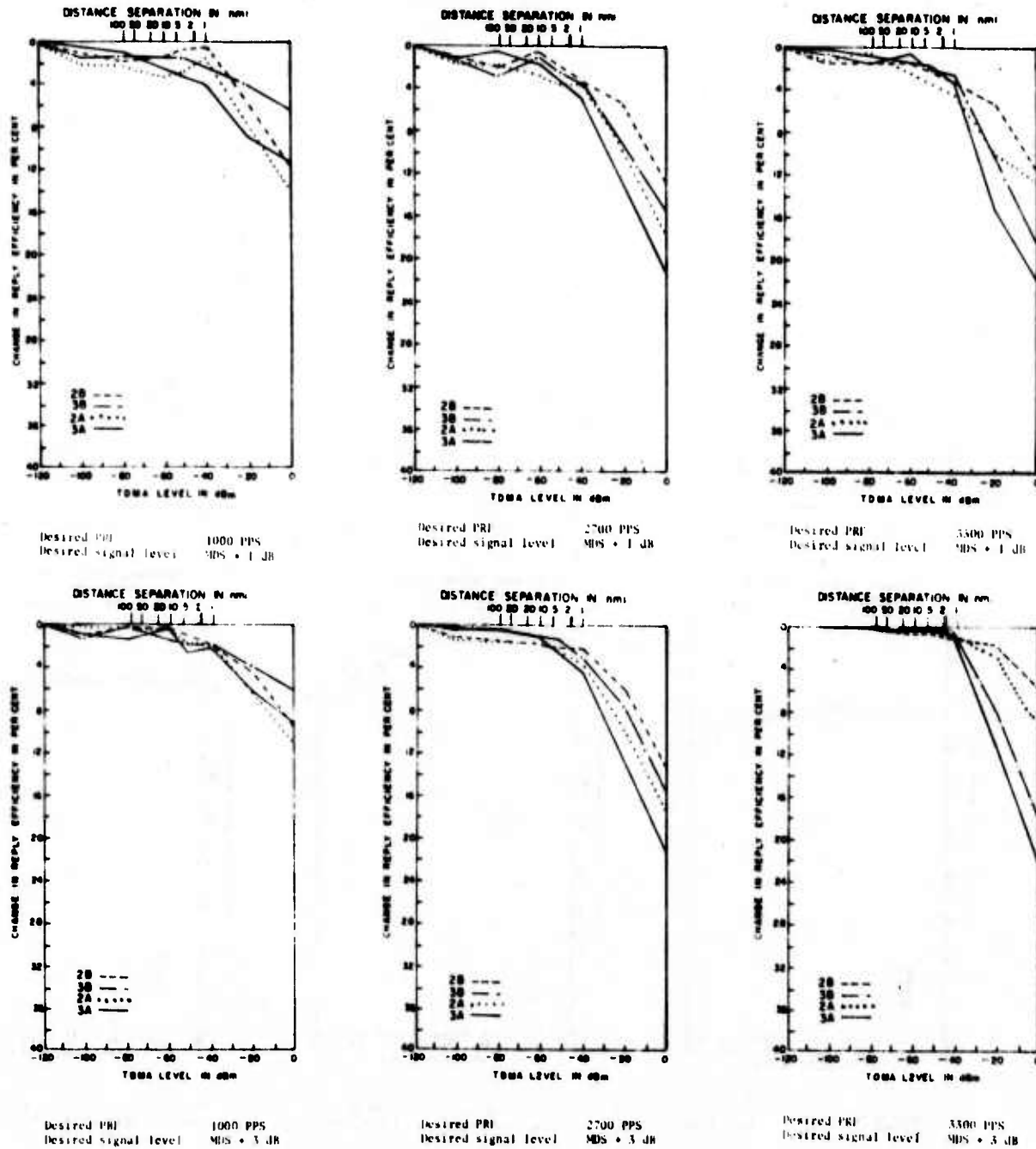

Figure B-10. RTB-2 beacon change in reply efficiency results for TDMA duty factor of 25%.

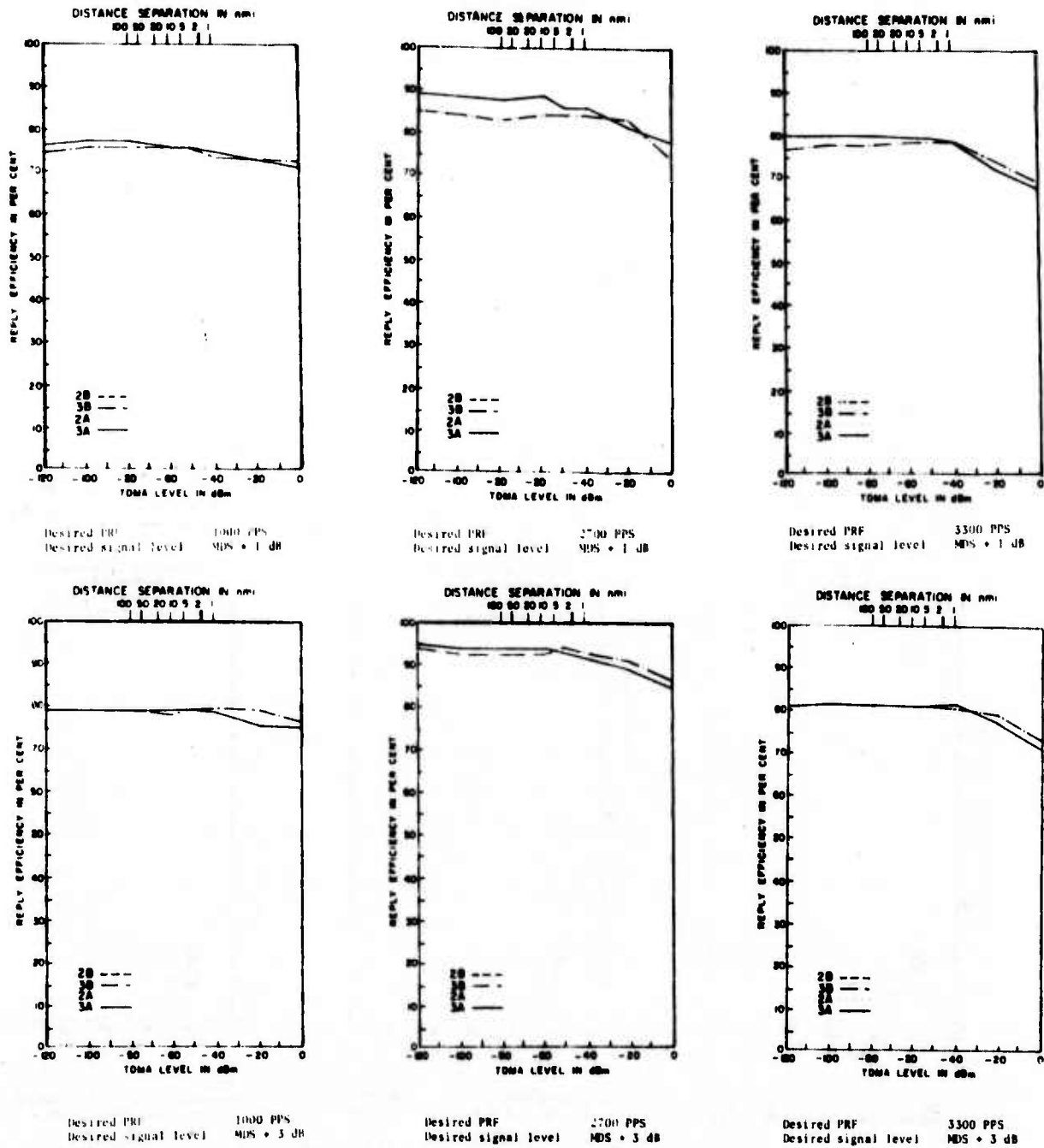

Figure B-11. RTB-2 beacon reply efficiency results for TDMA duty factor of 10%.

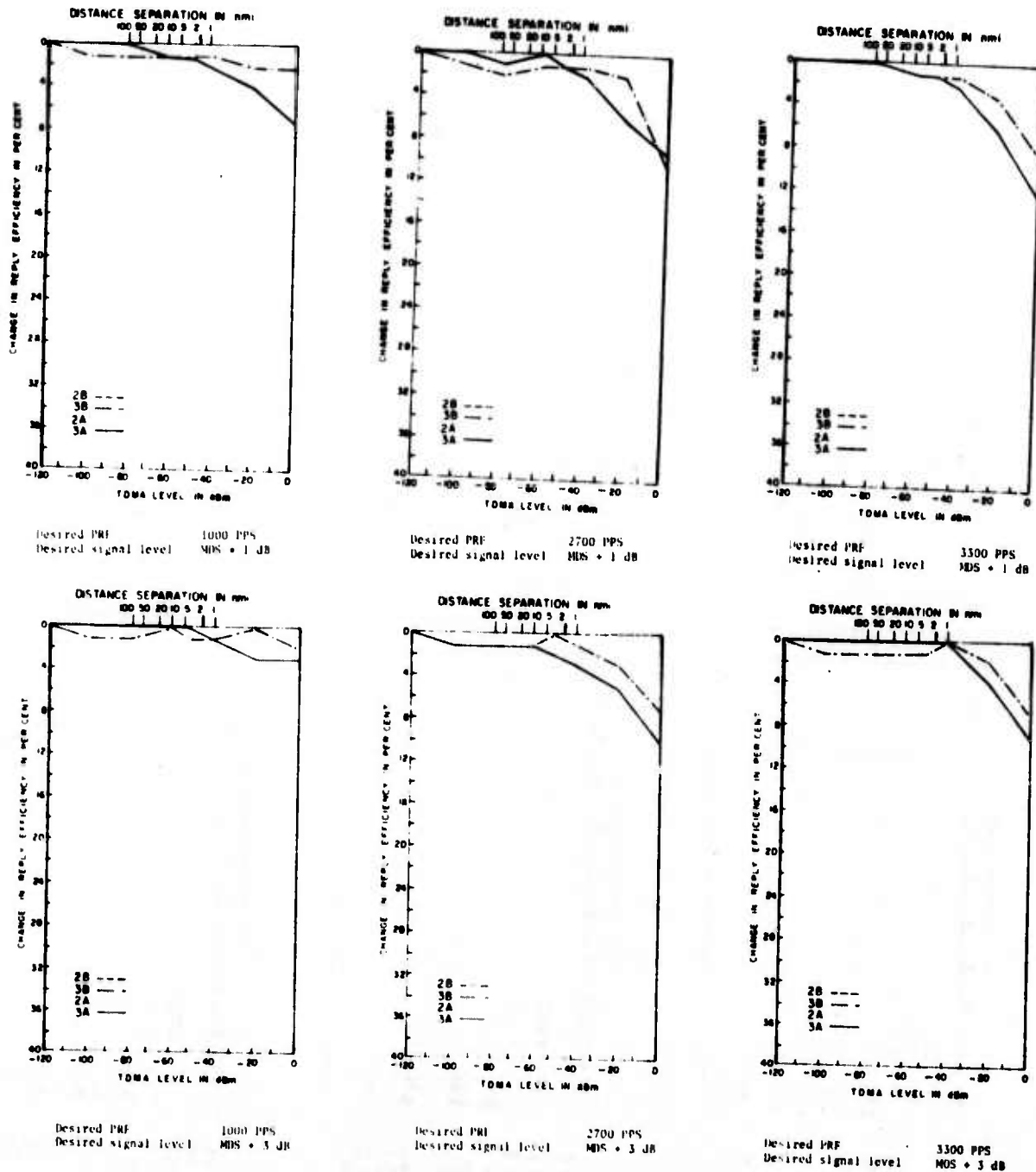

Figure B-12. RTB-2 beacon change in reply efficiency results for TDMA duty factor of 10%.

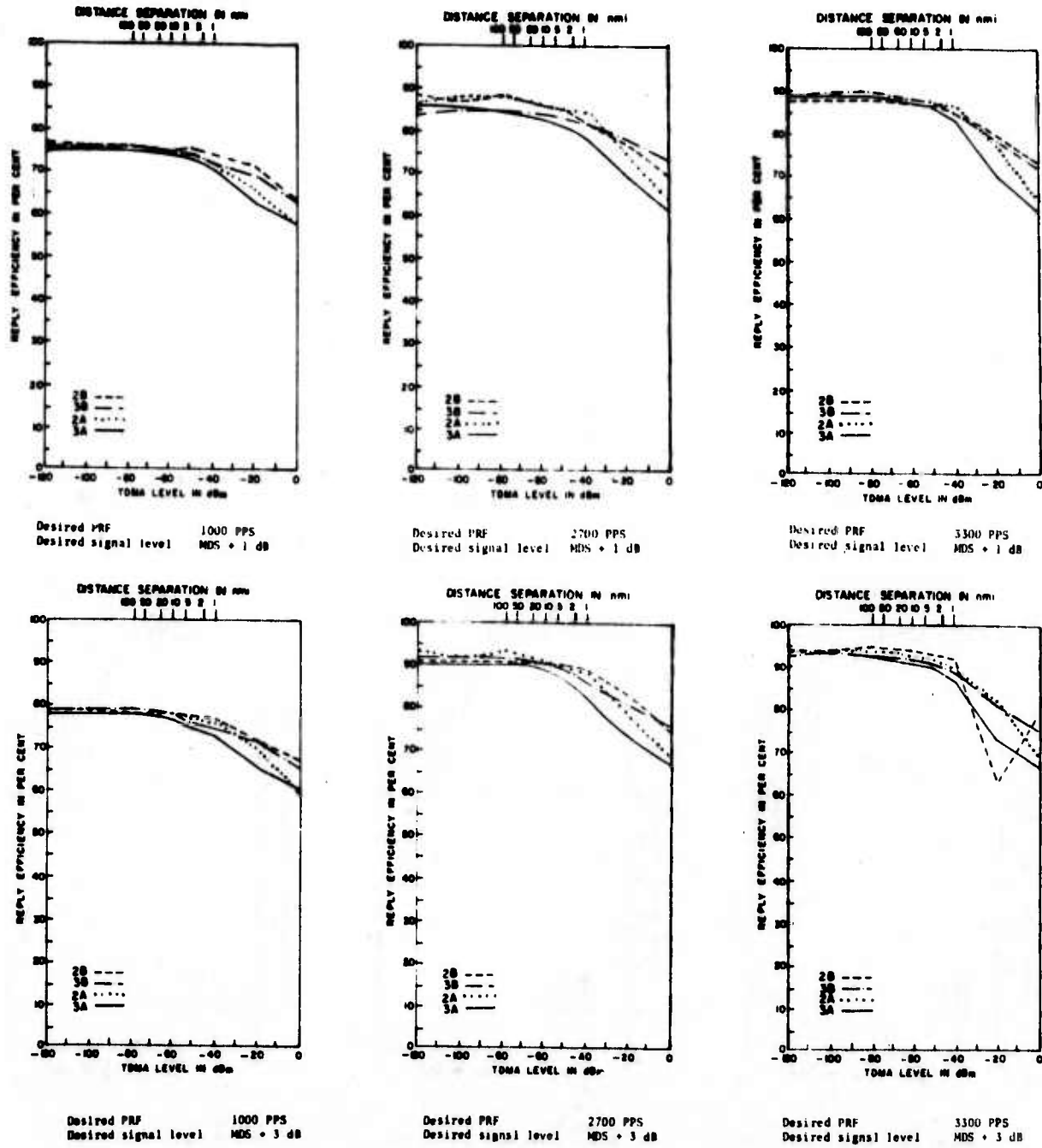

Figure B-13. Modified RTB-2 X mode beacon reply efficiency results for TDMA duty factor of 50%.

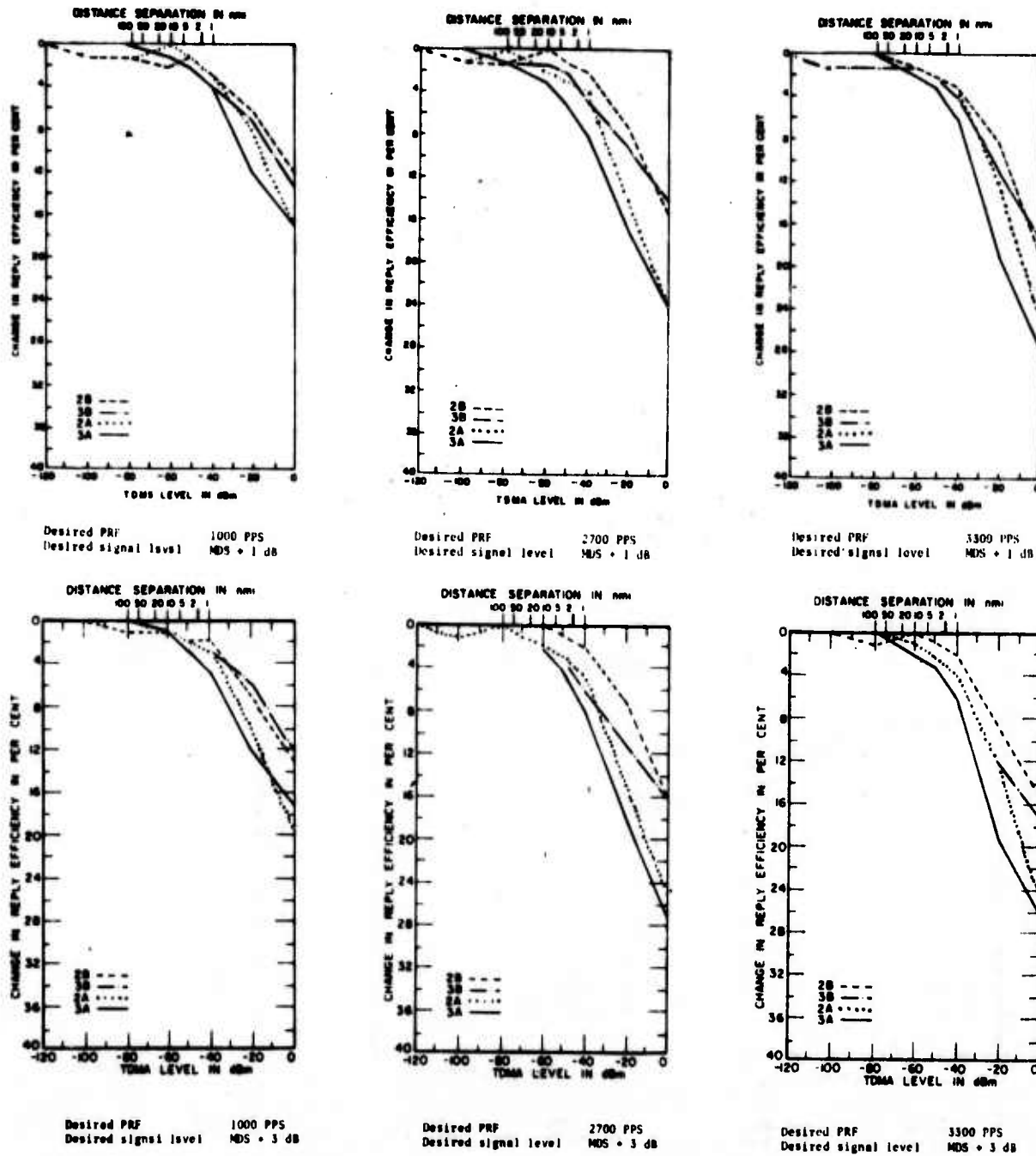

Figure B-14. Modified RTB-2 X mode beacon change in reply efficiency results for TDMA duty factor of 50%.

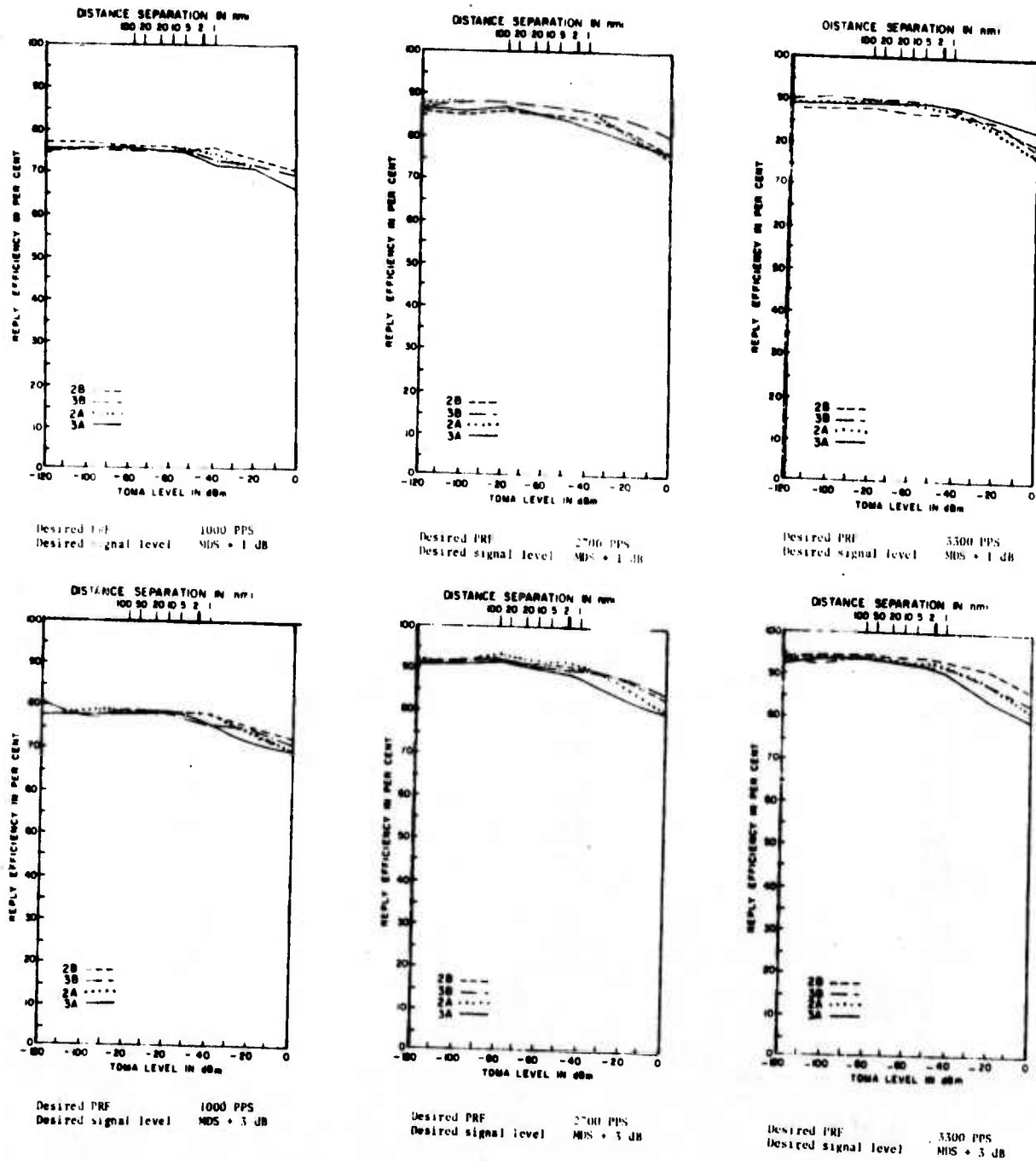

Figure B-15. Modified RTB-2 X mode beacon reply efficiency results for TDMA duty factor of 25%.

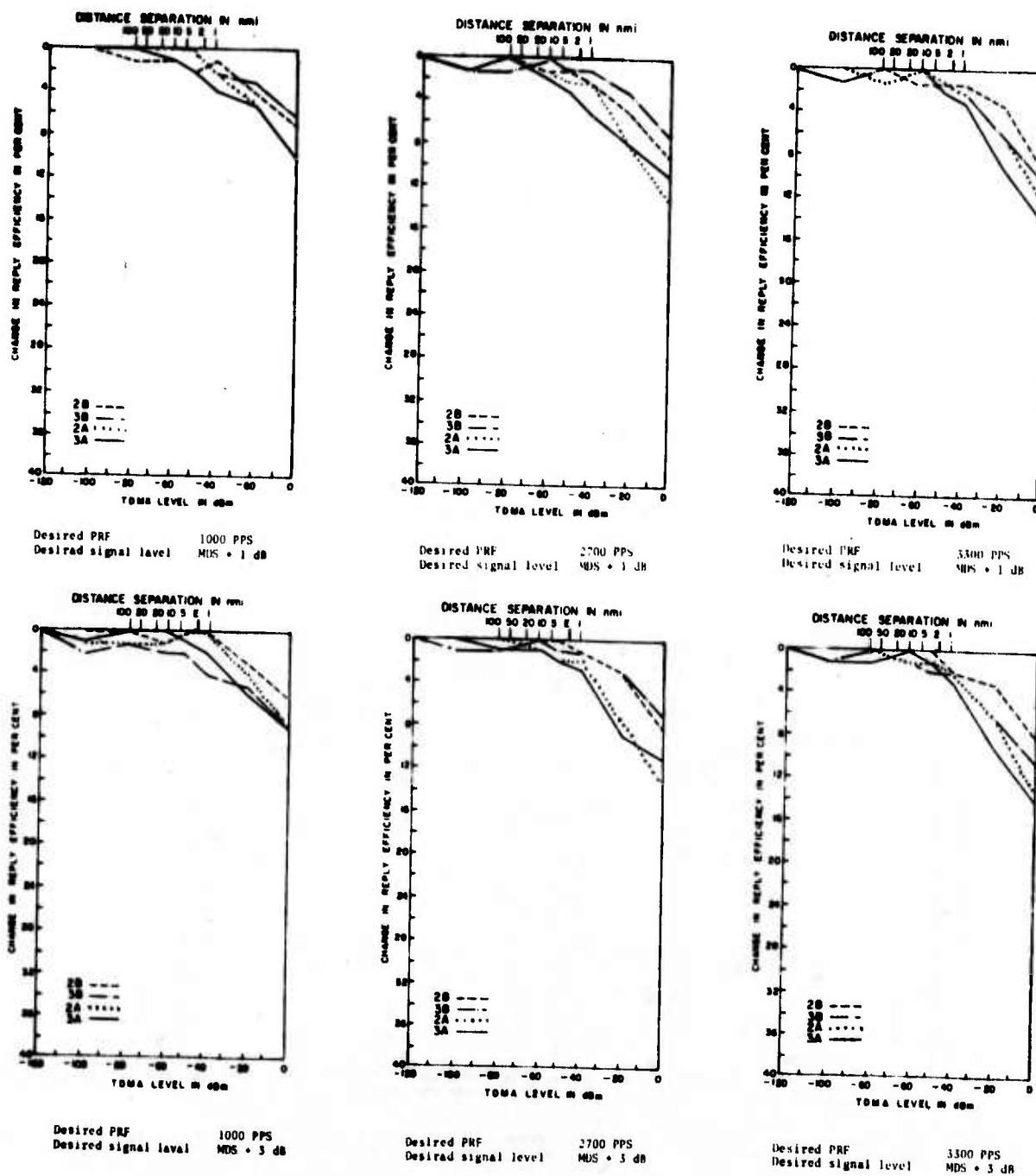

Figure B-16. Modified RTB-2 X mode beacon change in reply efficiency results for TDMA duty factor of 25%.

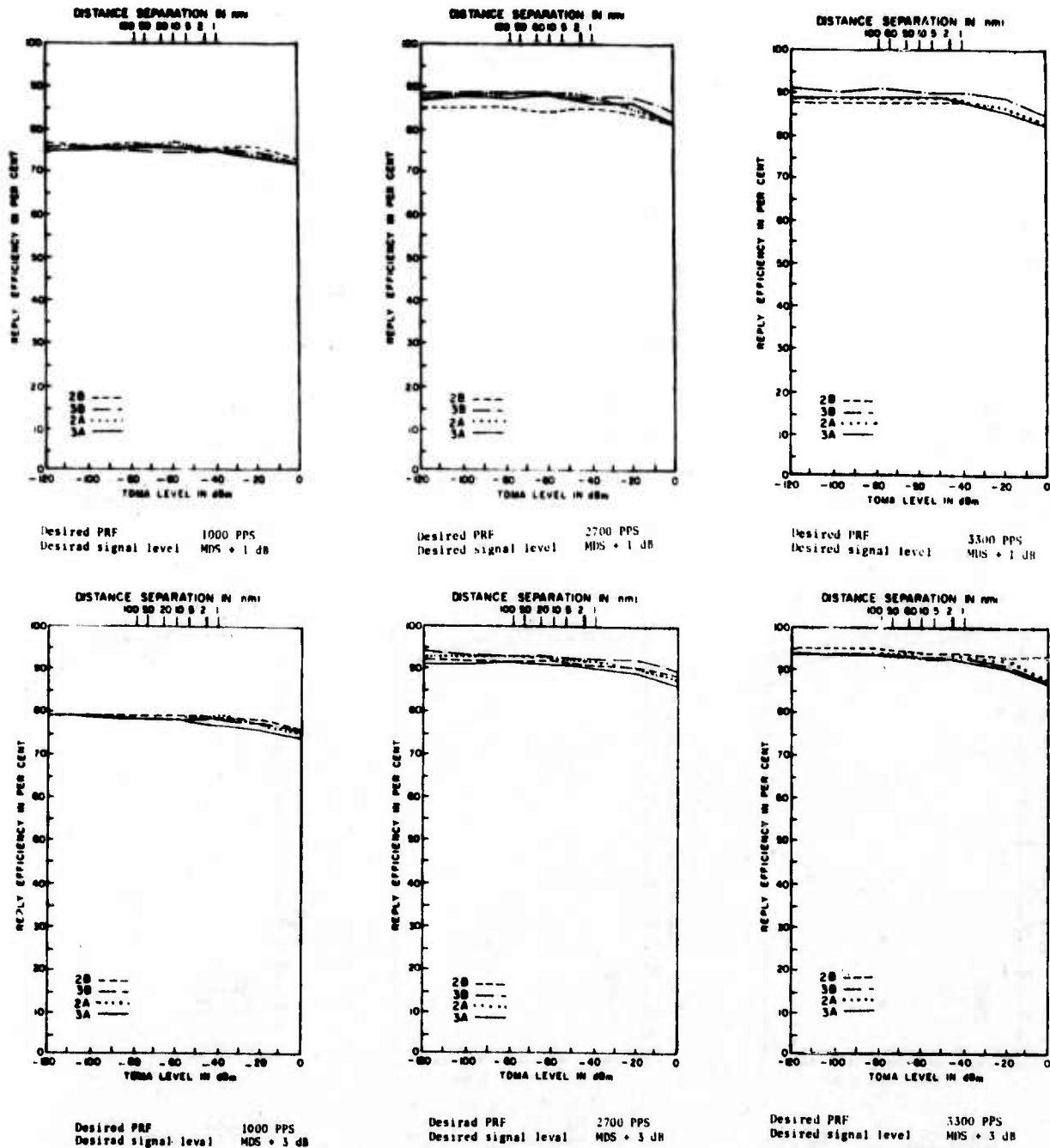

Figure B-17. Modified RTB-2 X mode beacon reply efficiency results for TDMA duty factor of 10%.

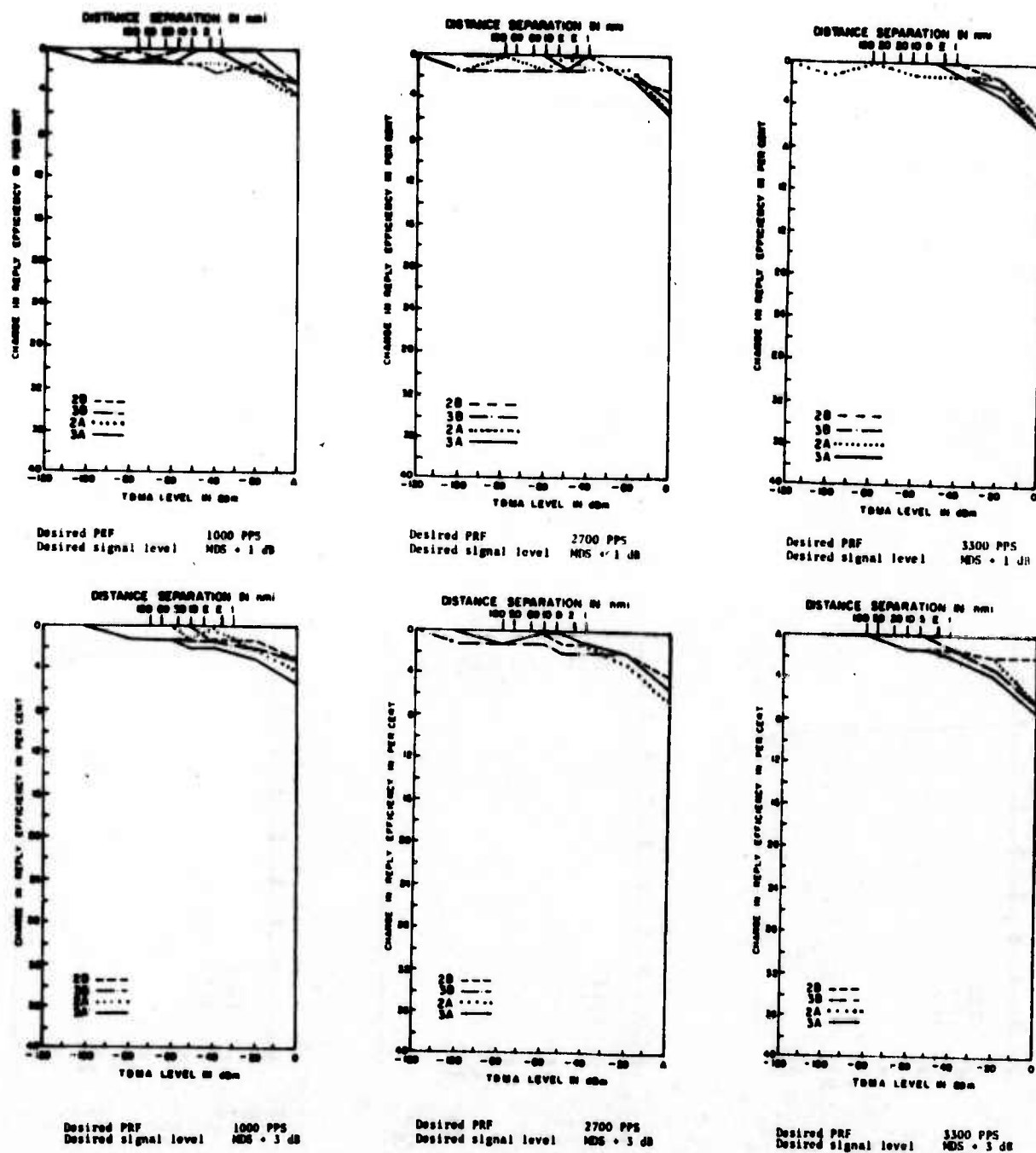

Figure B-18. Modified RTB-2 X mode beacon change in reply efficiency results for TDMA duty factor of 10%.

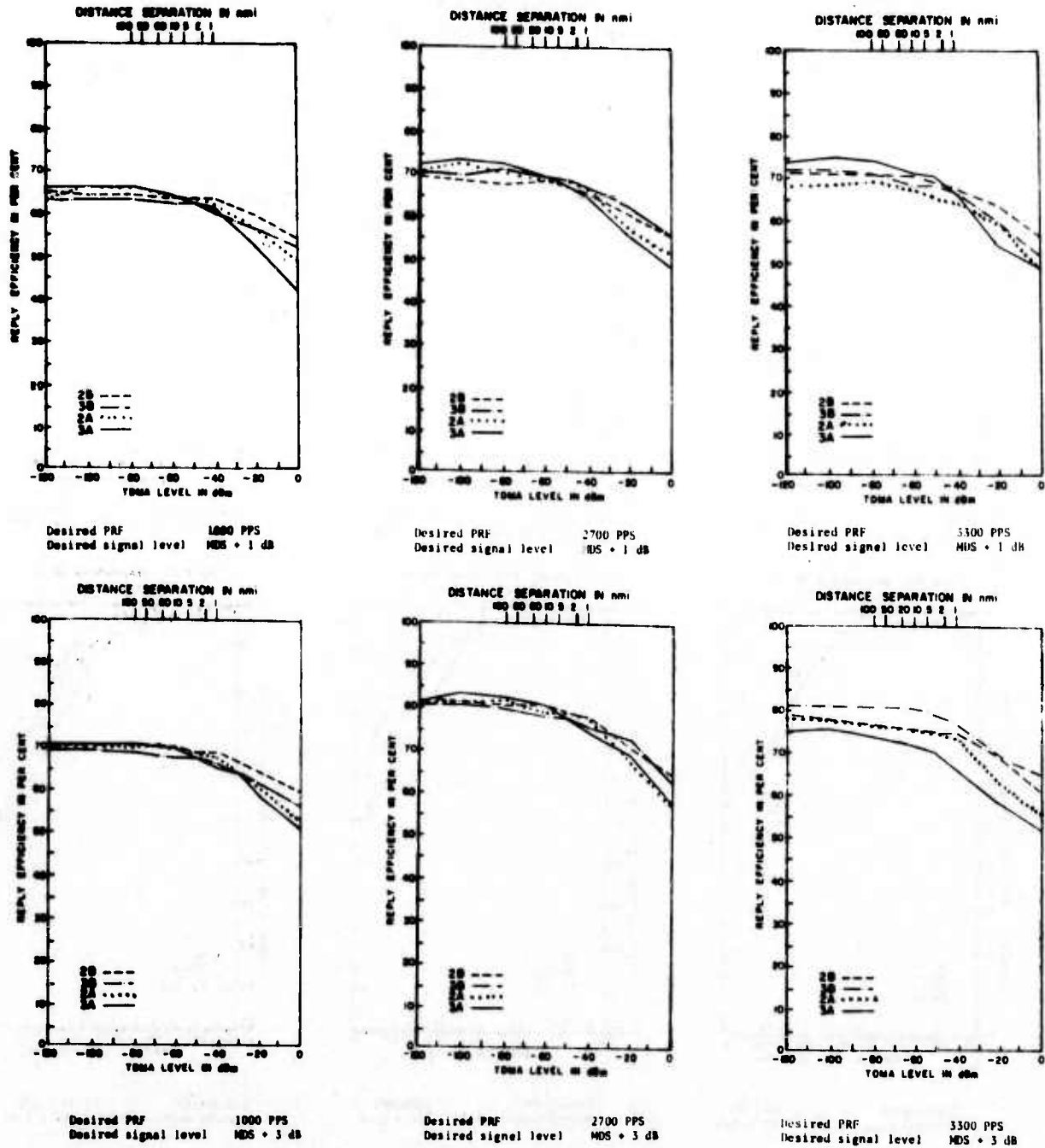

Figure B-19. Modified RTB-2 Y mode beacon reply efficiency results for TDMA duty factor of 50%.

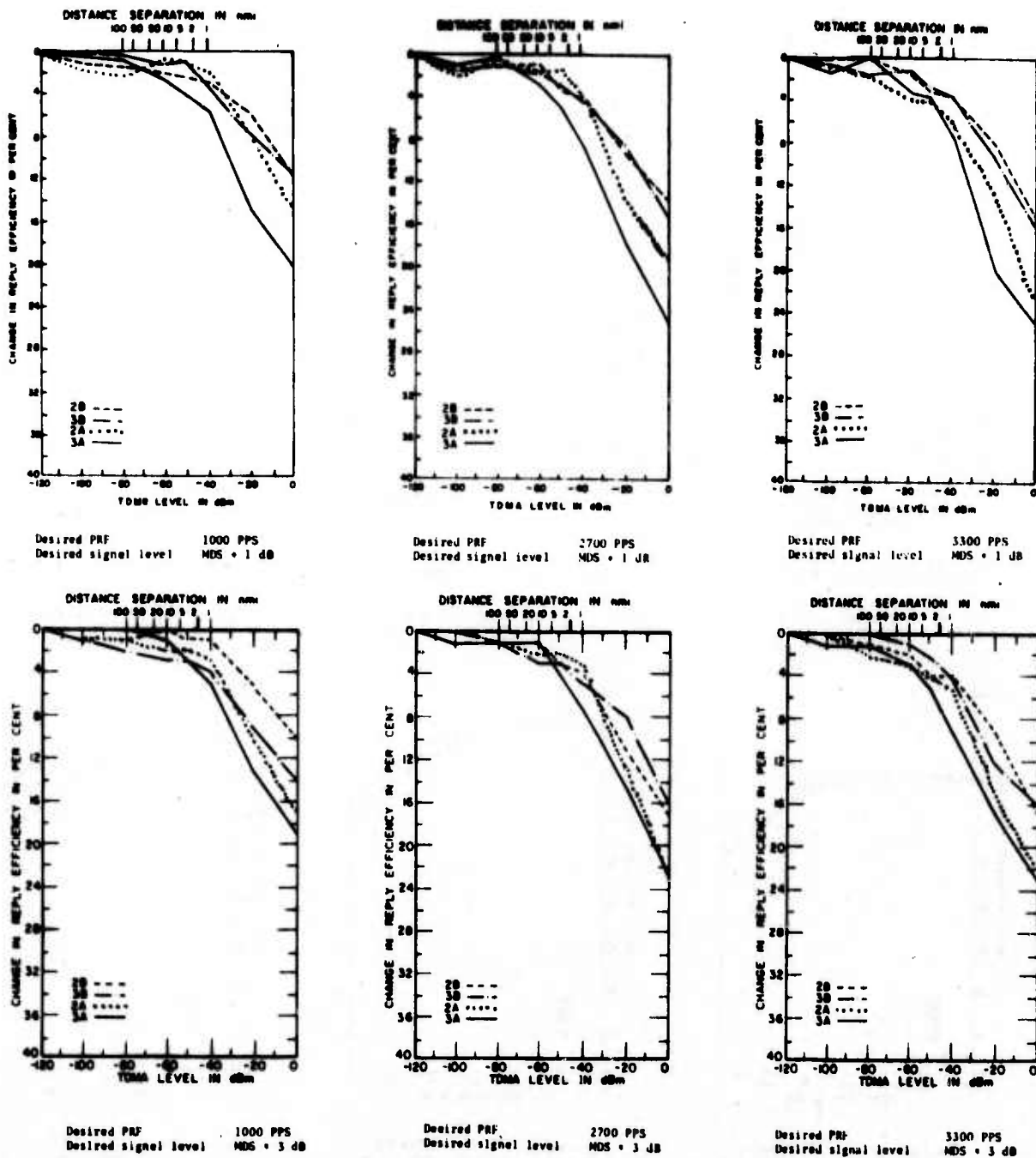

Figure B-20. Modified RTB-2 Y mode beacon change in reply efficiency results for TDMA duty factor of 50%.

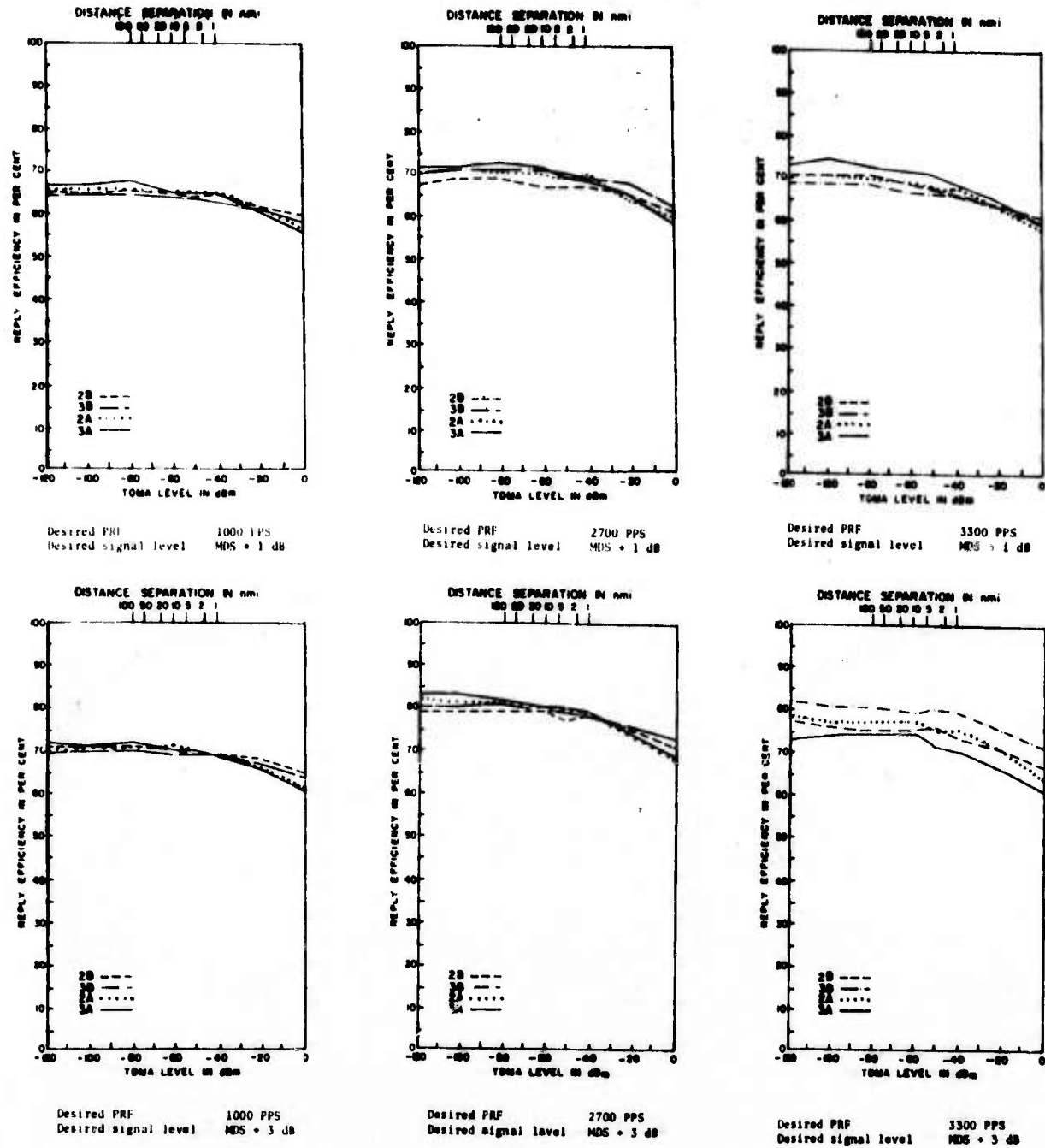

Figure B-21. Modified RTB-2 Y mode beacon reply efficiency results for TDMA duty factor of 25%.

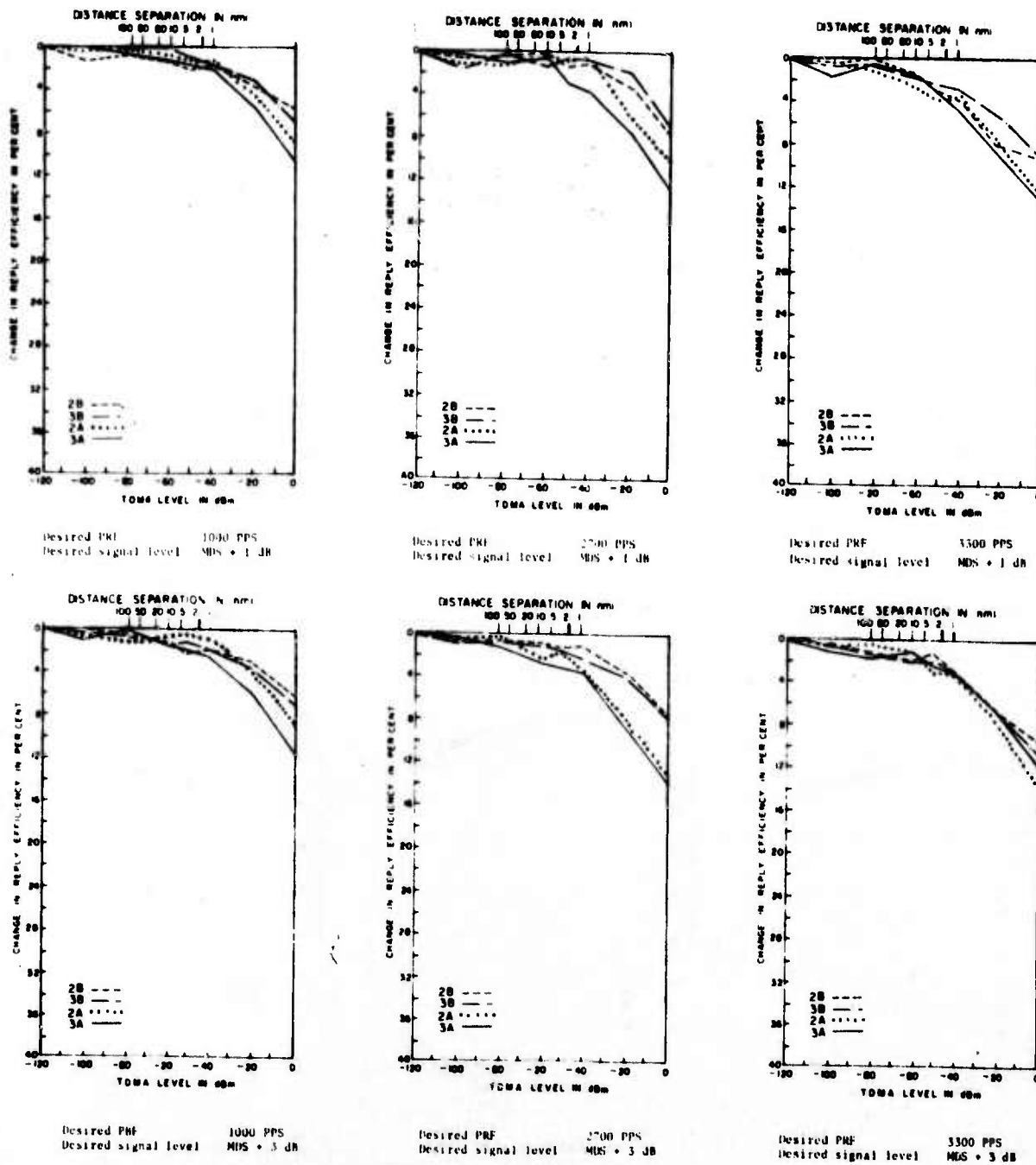

Figure B-22. Modified RTB-2 Y mode beacon change in reply efficiency results for TDMA duty factor of 25%.

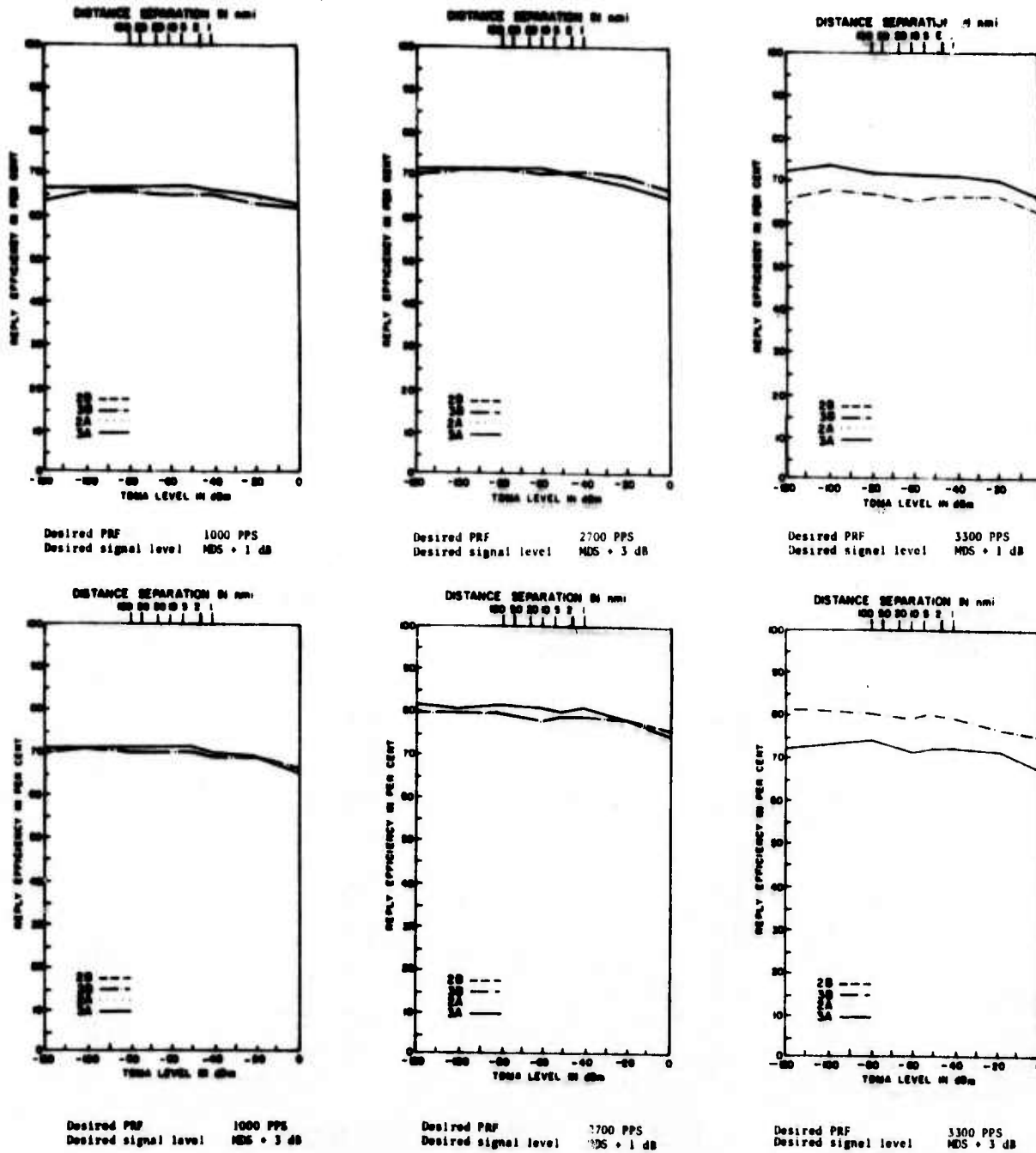

Figure B-23. Modified RTB-2 Y mode beacon reply efficiency results for TDMA duty factor of 10%.

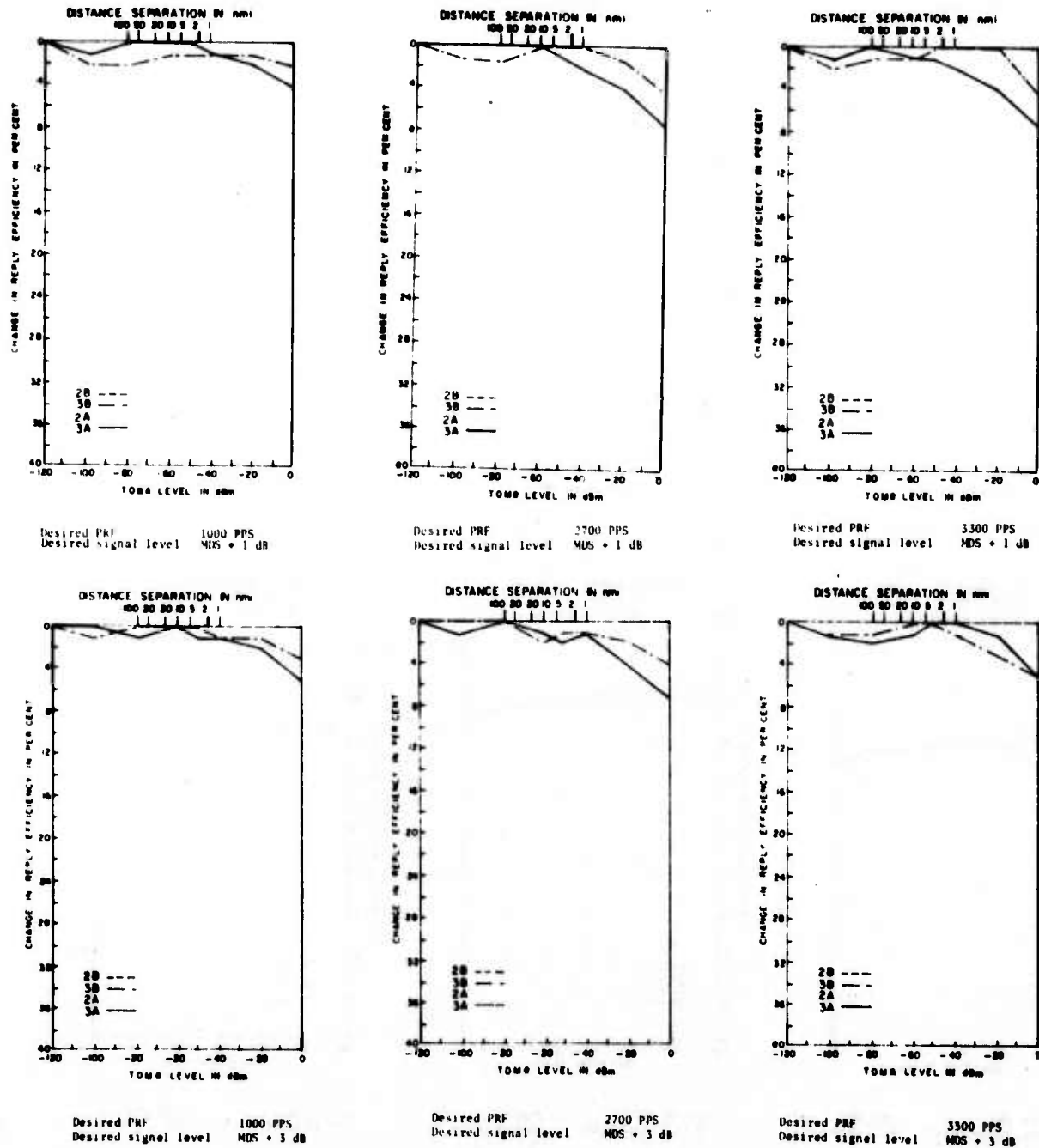

Figure B-24. Modified RTB-2 Y mode beacon change in reply efficiency results for TDMA duty factor of 10%.

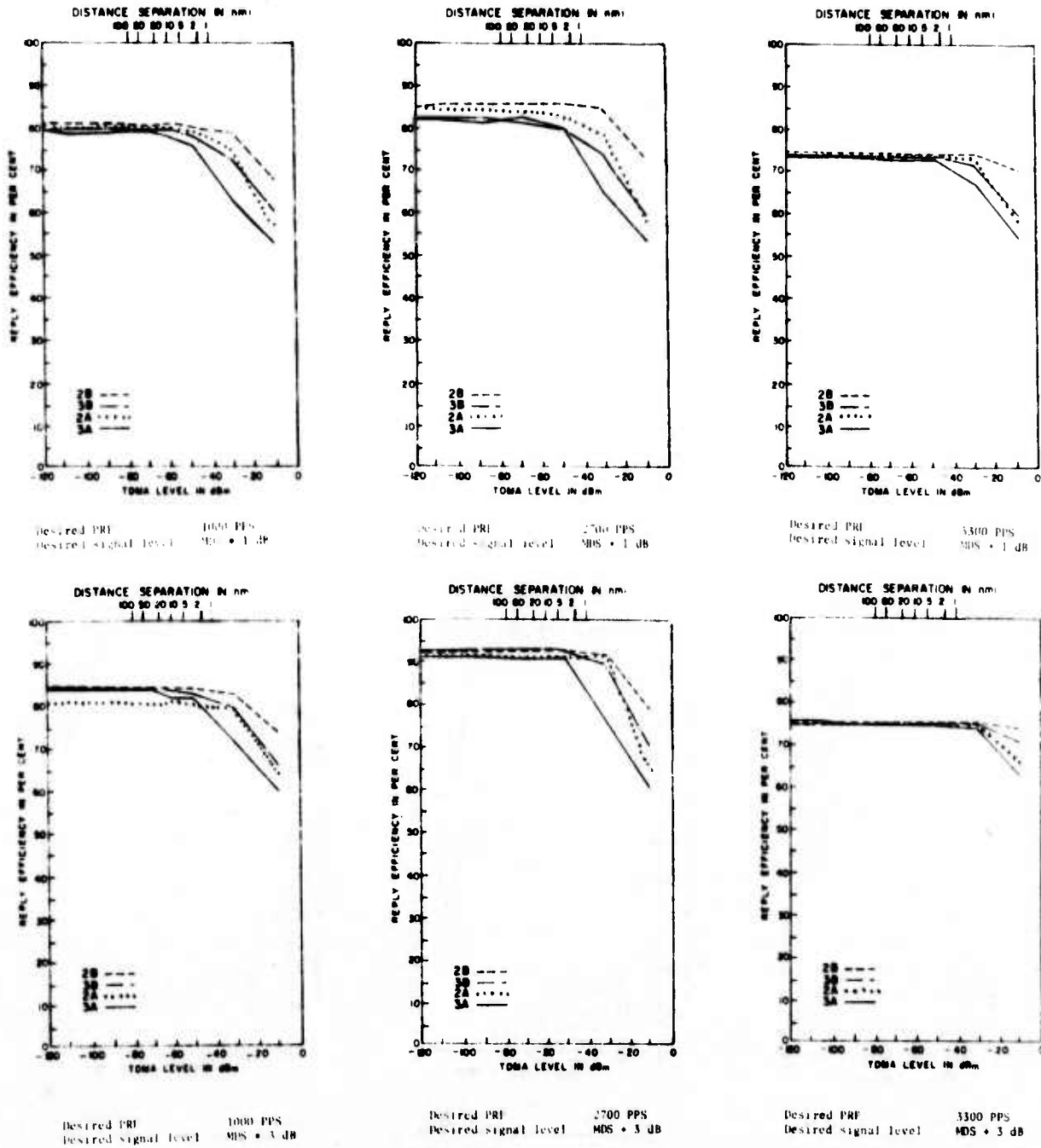

Figure B-25. Butler DME beacon reply efficiency results for TDMA duty factor of 50%.

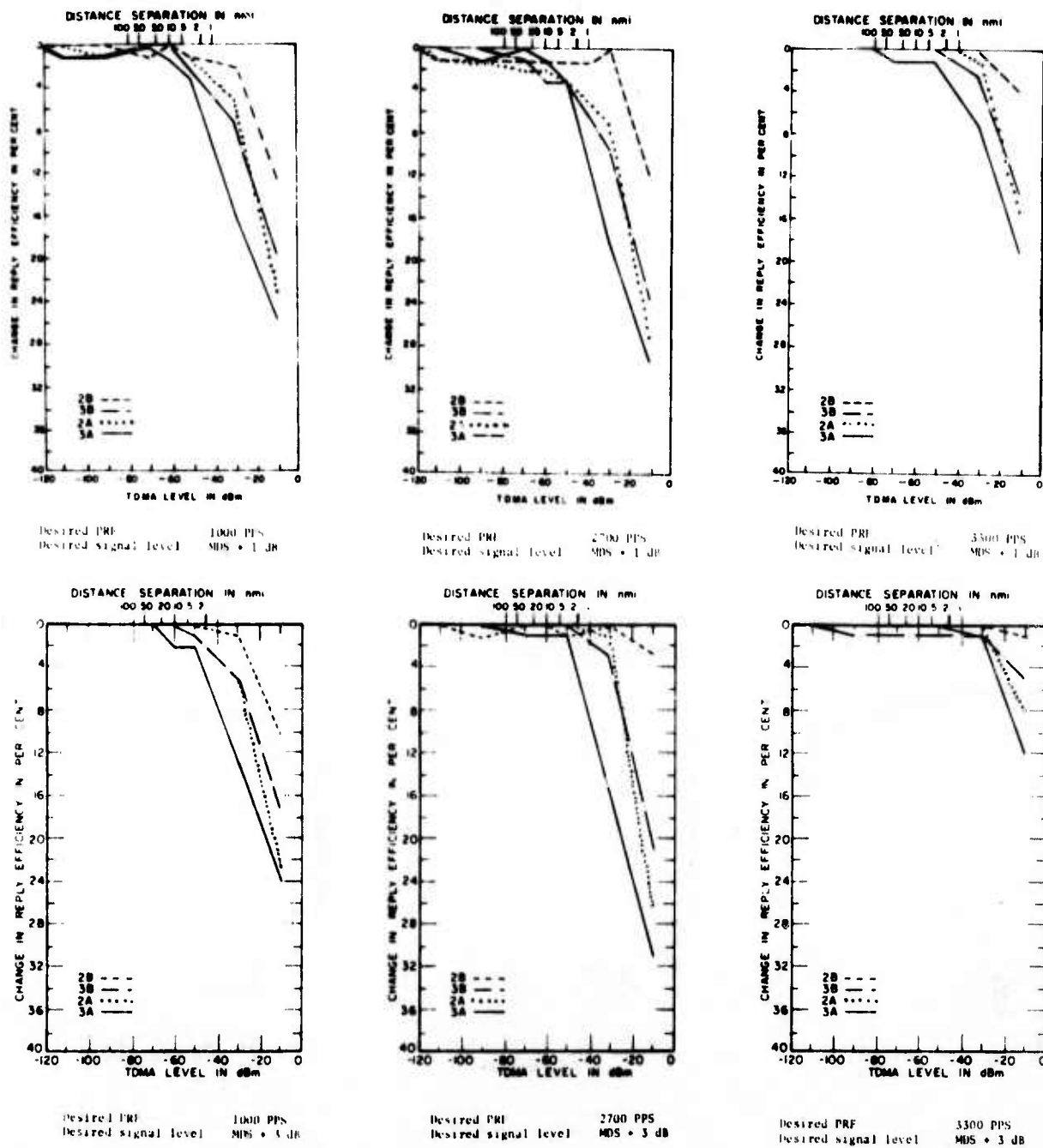
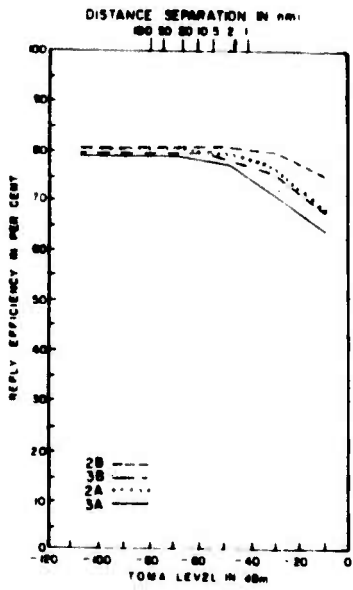
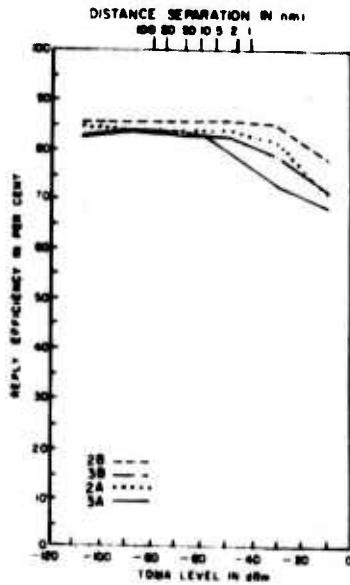

Figure B-26. Butler DME beacon change in reply efficiency results for TDMA duty factor of 50%.



Desired PRF 1000 PPS  
Desired signal level MDS + 1 dB



Desired PRF 2700 PPS  
Desired signal level MDS + 1 dB

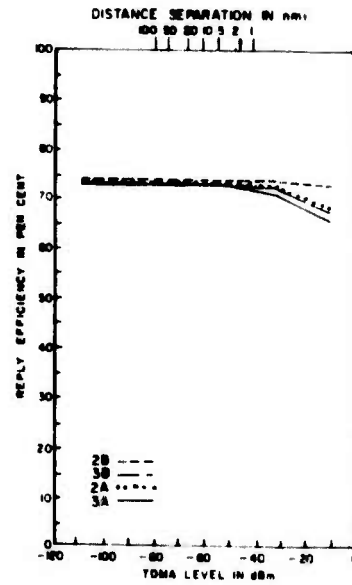

Desired PRF 5300 PPS  
Desired signal level MDS + 1 dB

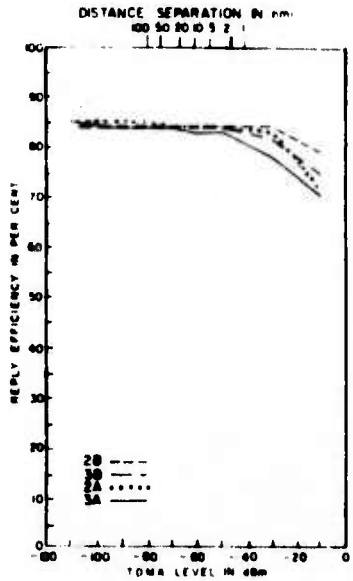

Desired PRF 1000 PPS  
Desired signal level MDS + 3 dB

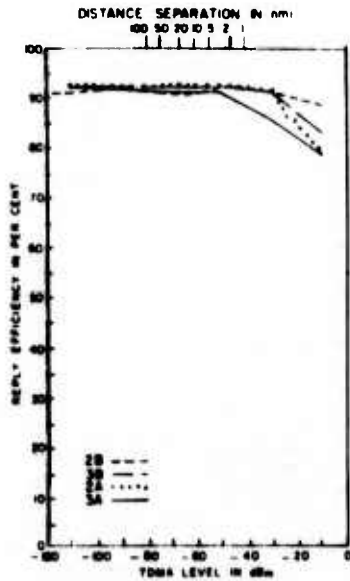

Desired PRF 2700 PPS  
Desired signal level MDS + 3 dB



Desired PRF 3300 PPS  
Desired signal level MDS + 3 dB

Figure B-27. Butler DME beacon reply efficiency results for TDMA duty factor of 25%.

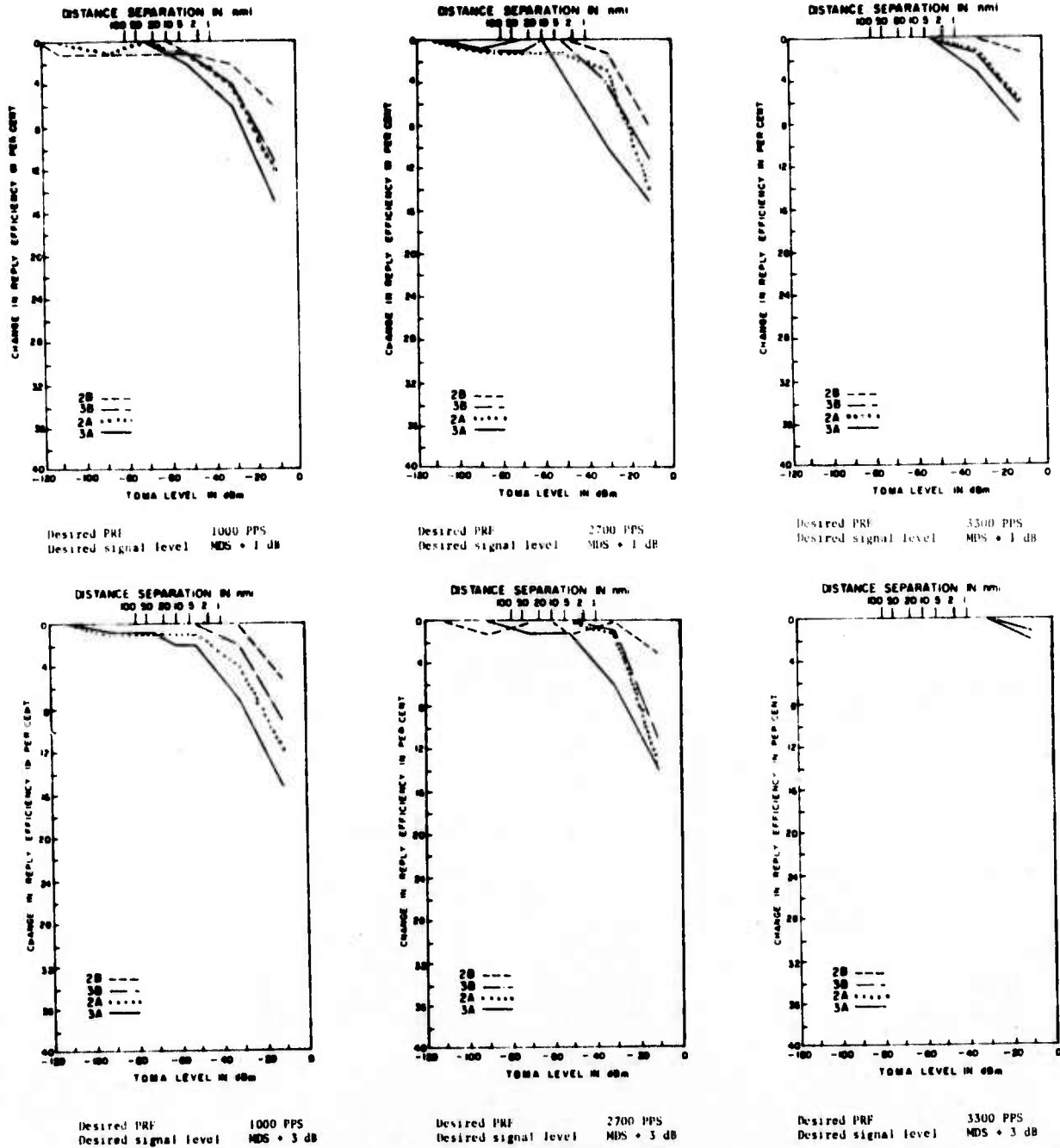

Figure B-28. Butler DME beacon change in reply efficiency results for TDMA duty factor of 25%.

APPENDIX C

TACAN BEACON LOADING TEST RESULTS

CONTENTS

<u>Figure</u>	<u>Page</u>
C-1 RTB-2 beacon loading results for waveform 3A (50% TDMA duty cycle) . . . . .	131
C-2 RTB-2 beacon loading results for waveform 3B (50% TDMA duty cycle) . . . . .	132
C-3 RTB-2 beacon loading results for waveform 2A (50% TDMA duty cycle) . . . . .	133
C-4 RTB-2 beacon loading results for waveform 2B (50% TDMA duty cycle) . . . . .	134
C-5 AN/GRN-9 beacon loading results for waveform 3A (50% TDMA duty cycle) . . . . .	135
C-6 AN/GRN-9 beacon loading results for waveform 3B (50% TDMA duty cycle) . . . . .	136
C-7 Butler beacon loading test results . . . . .	137
C-8 Butler beacon loading test results continued . . . . .	138
C-9 Modified RTB-2 X mode beacon loading test results . . . . .	139
C-10 Modified RTB-2 X mode beacon loading test results continued . . . . .	140
C-11 Modified RTB-2 Y mode beacon loading test results . . . . .	141
C-12 Modified RTB-2 Y mode beacon loading test results continued . . . . .	142

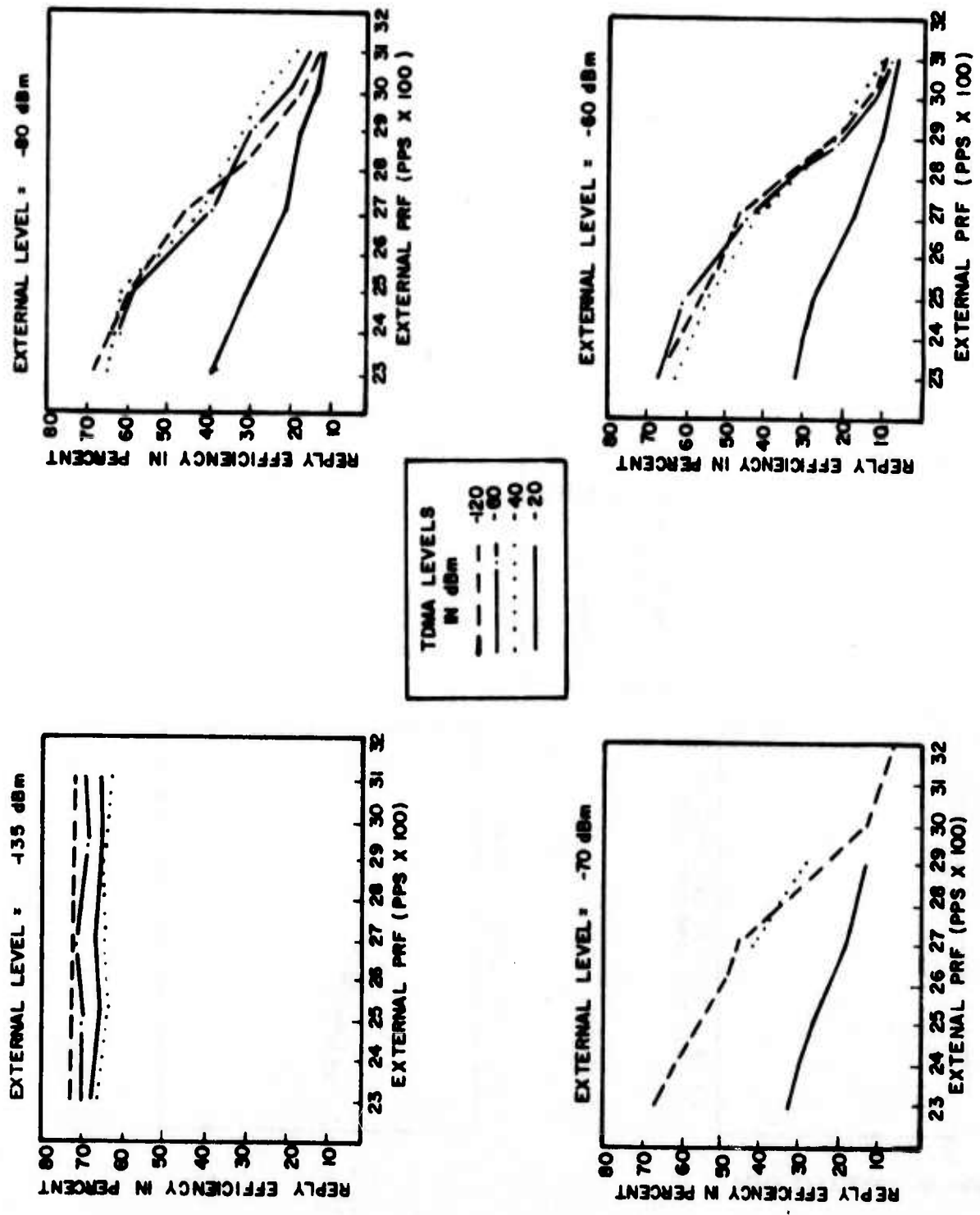

Figure C-1. RTB-2 beacon loading results for waveform 3A (50% TDMA duty cycle, desired signal at MDS + 1 db and 500 pps).

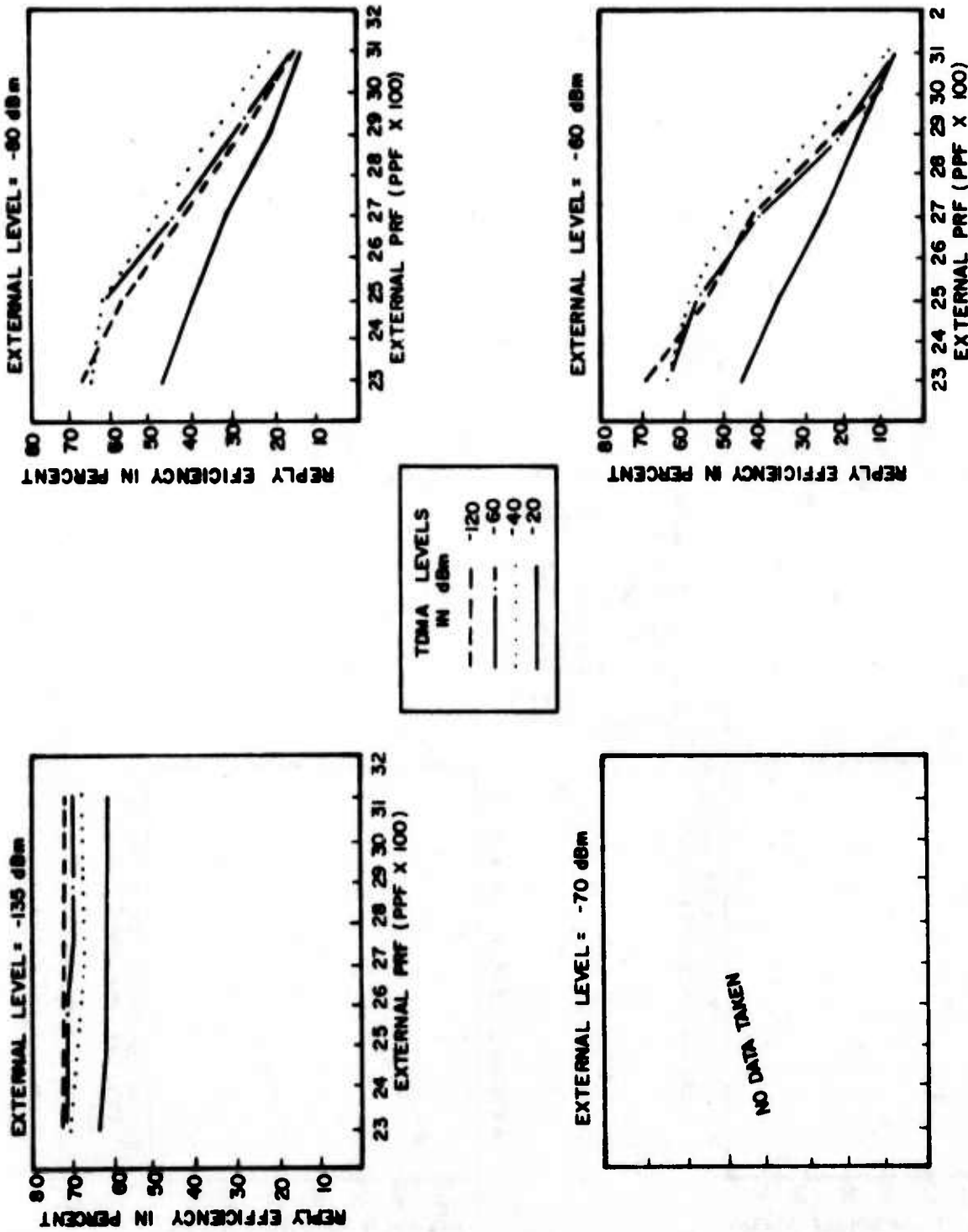

Figure C-2. RTB-2 beacon loading results for waveform 3B (50% TDMA duty cycle, desired signal at MDS + 1 dB and 500 pps).

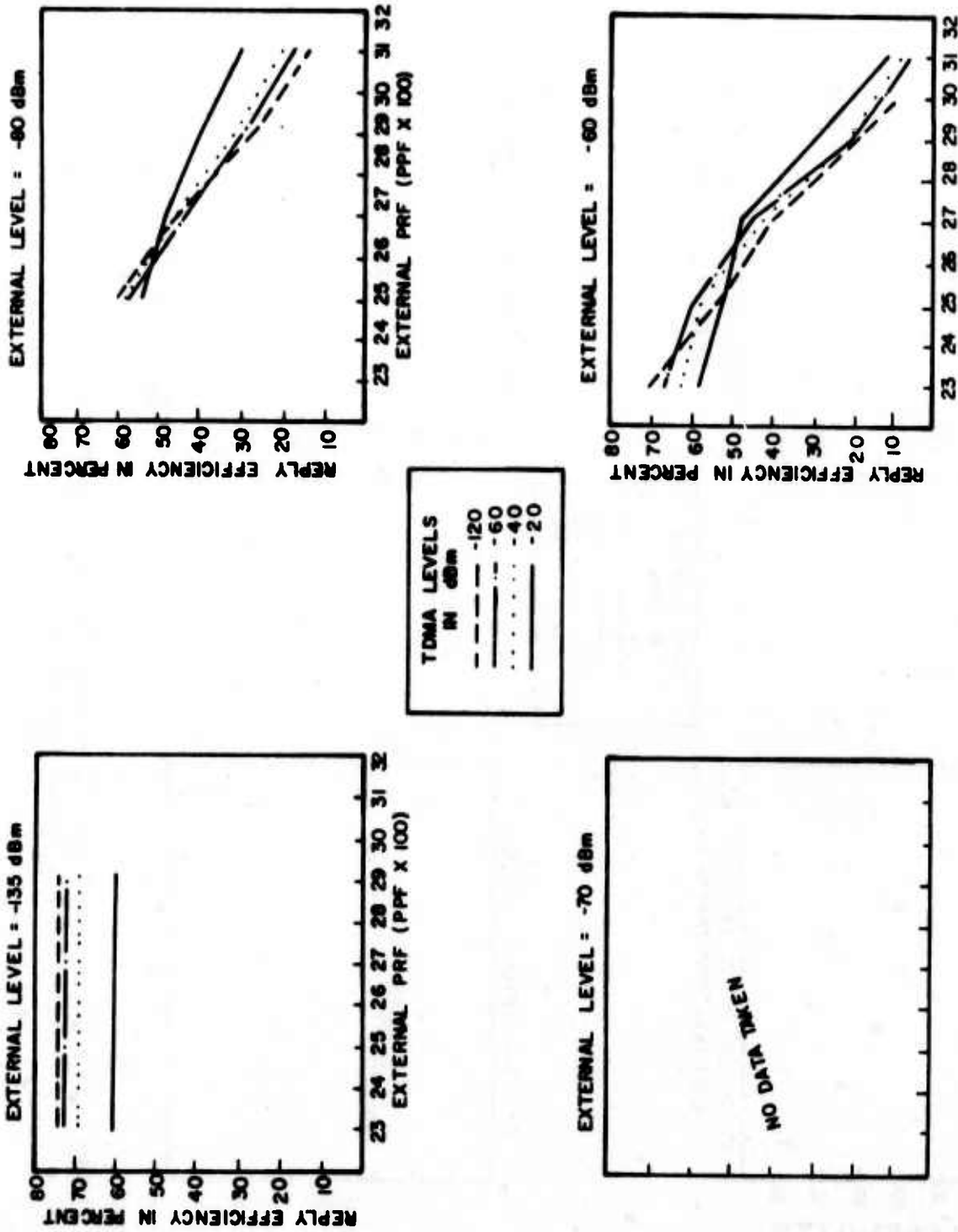

Figure C-3. RTB-2 beacon loading results for waveform 2A (50% TDMA duty cycle, desired signal at MDS + 1 dB and 500 pps).

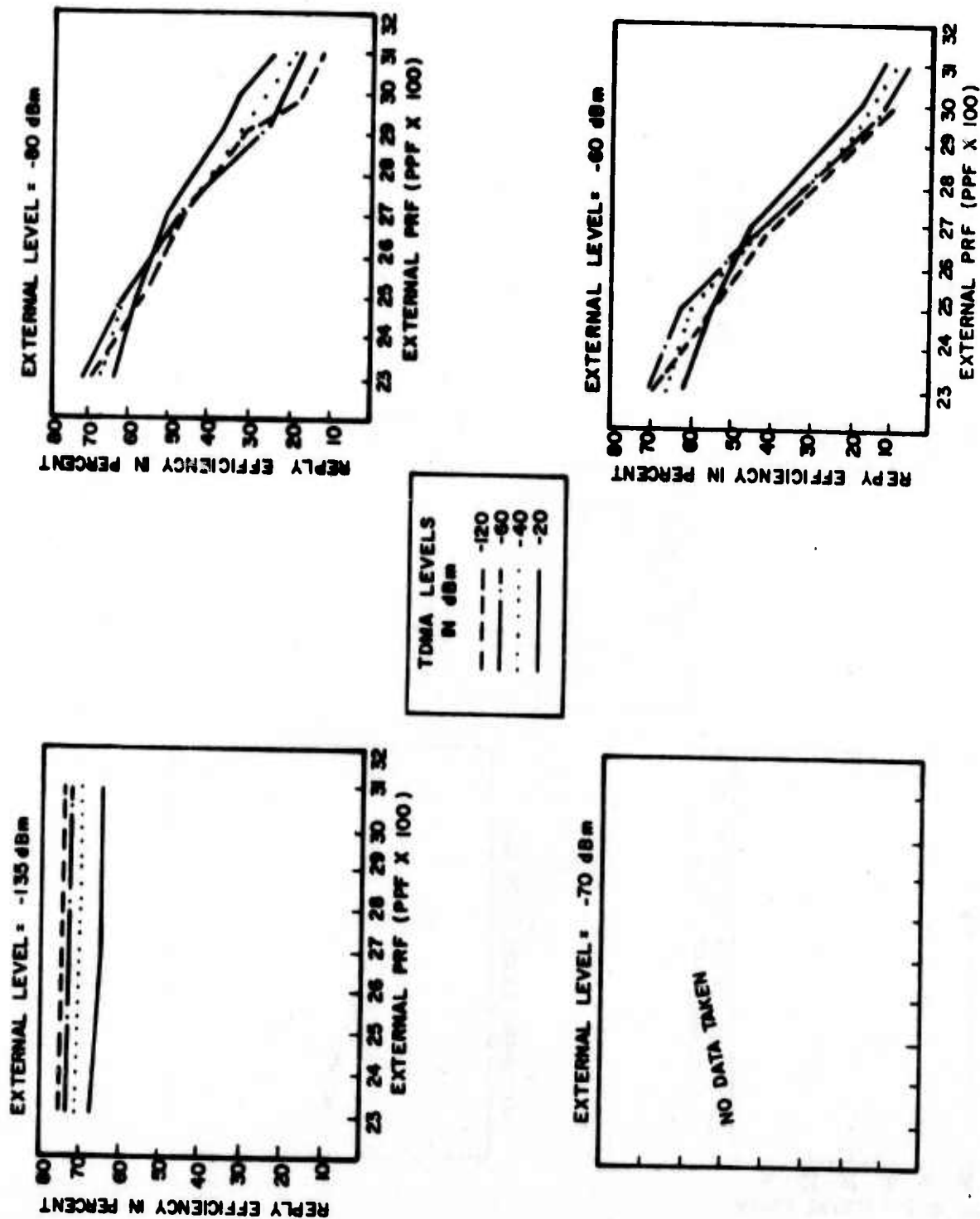

Figure C-4. RTB-2 beacon loading results for waveform 2B (50% TDMA duty cycle, desired signal at MDS + 1 dB and 500 pps).

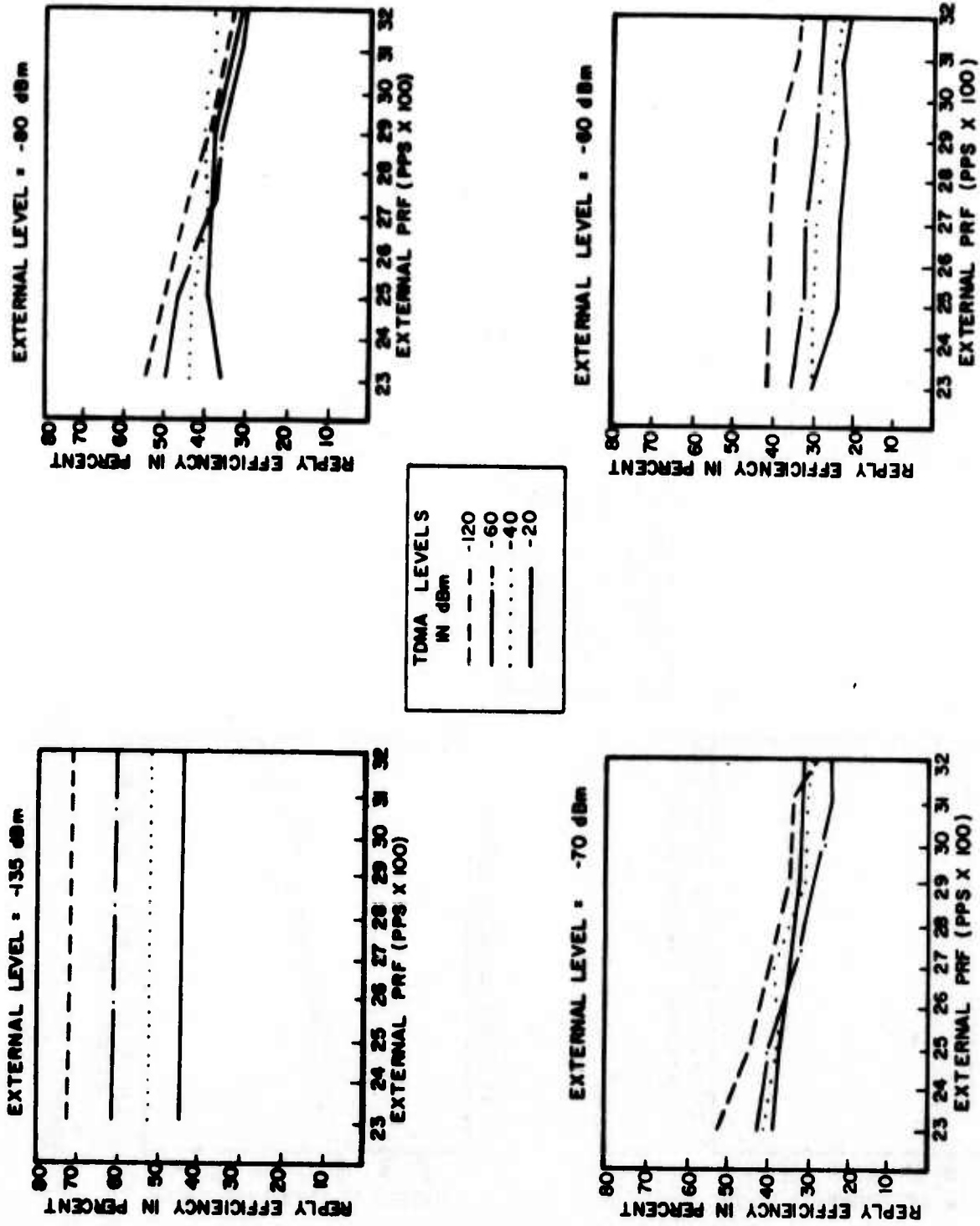

Figure C-5. AN/GRN-9 beacon loading results for waveform 3A (50% TDMA duty cycle, desired signal at MDS + 1 dB and 500 pps).

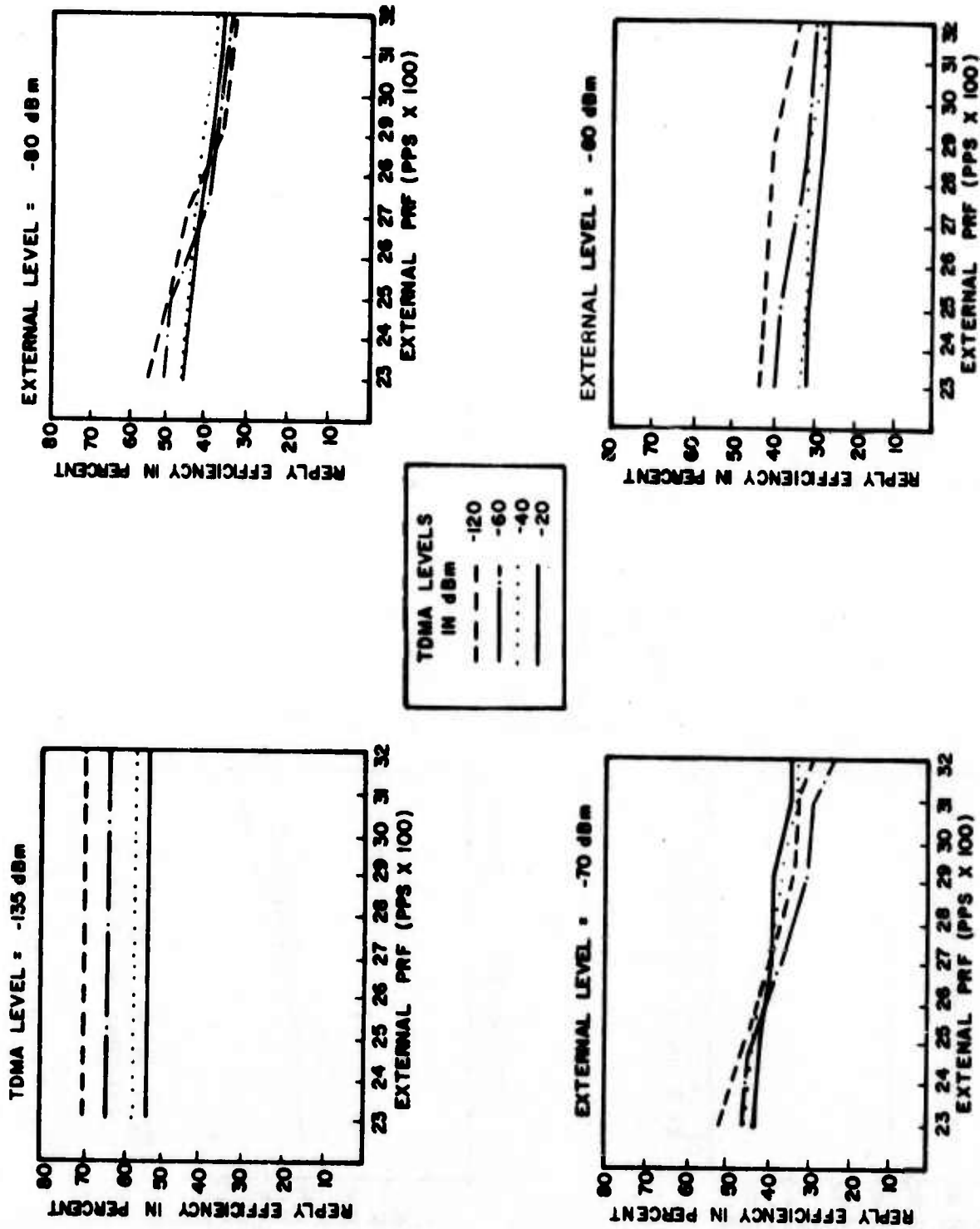

Figure C-6. AN/GRN-9 beacon loading results for waveform 3B (50% TDMA duty cycle, desired signal at MDS + 1 dB and 500 pps).

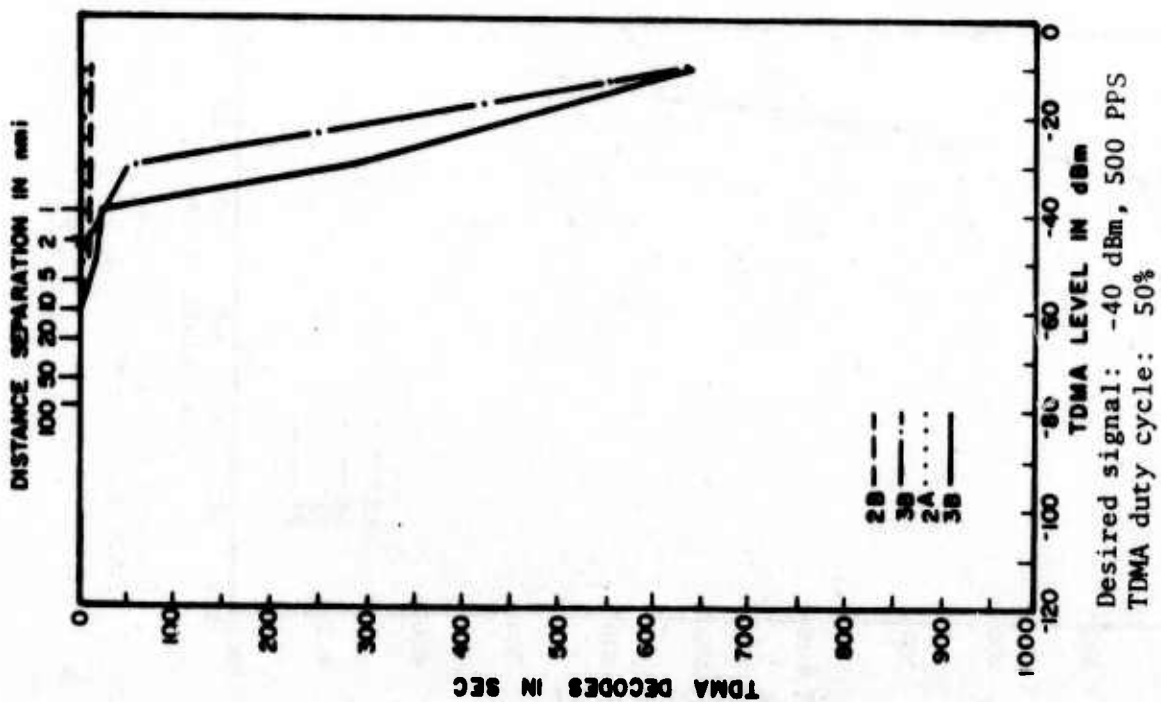
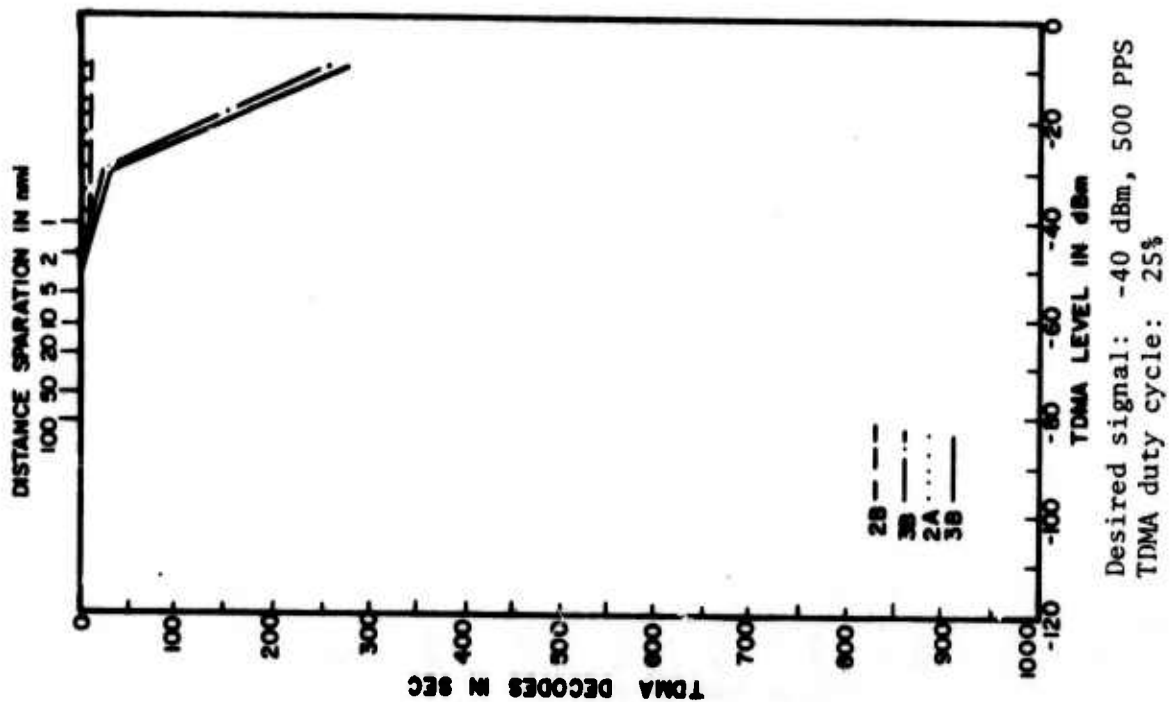

Figure C-7. Butler beacon loading test results.

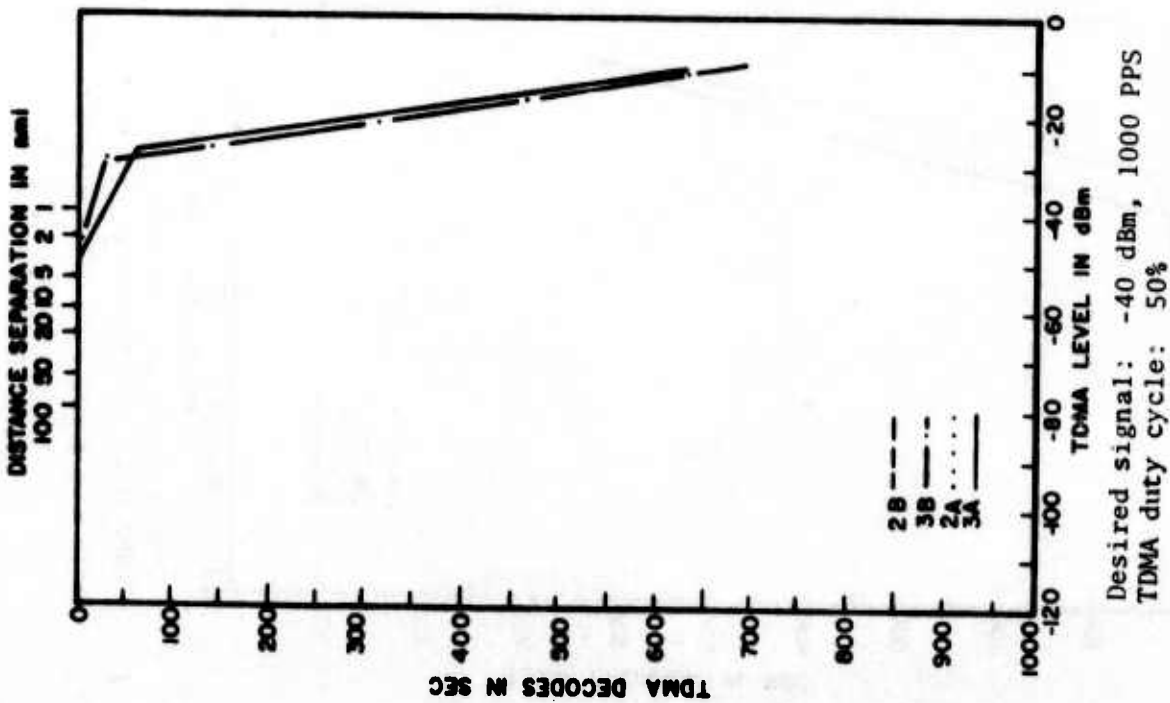
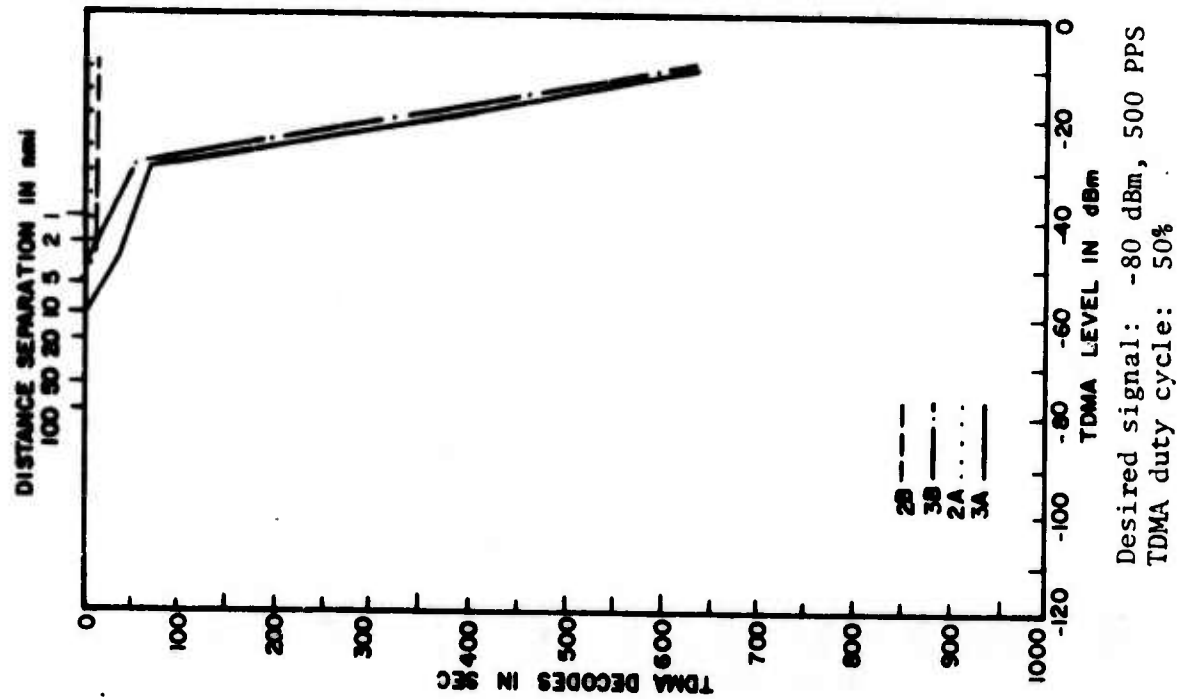

Figure C-8. Butler beacon loading test results continued.

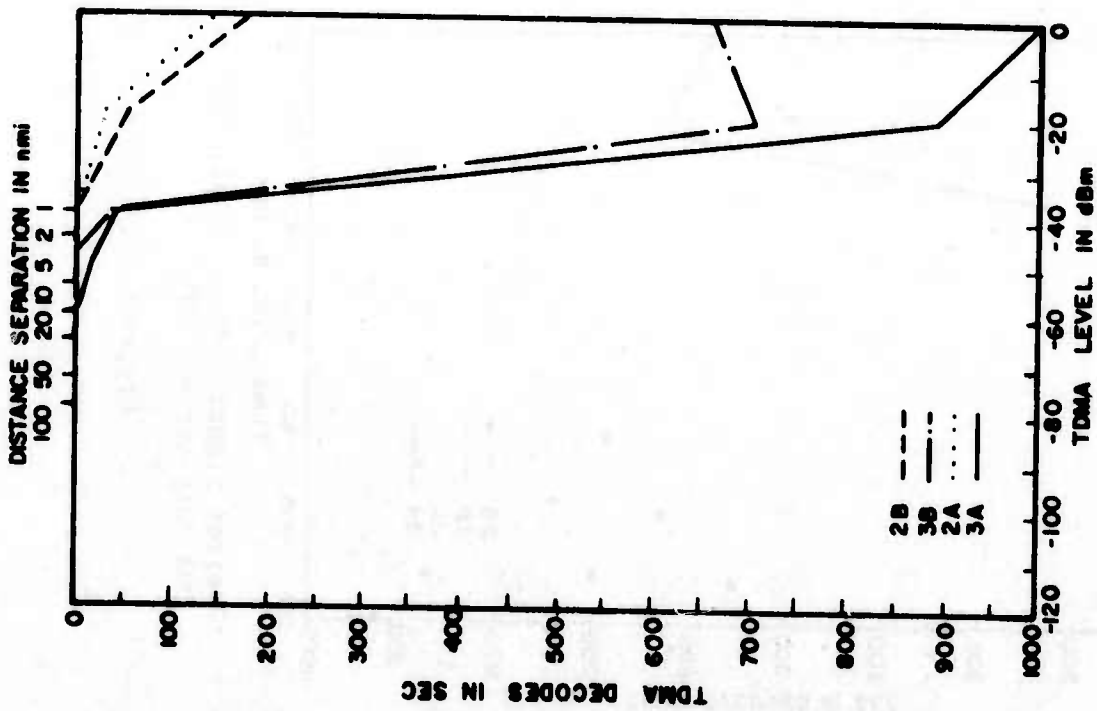
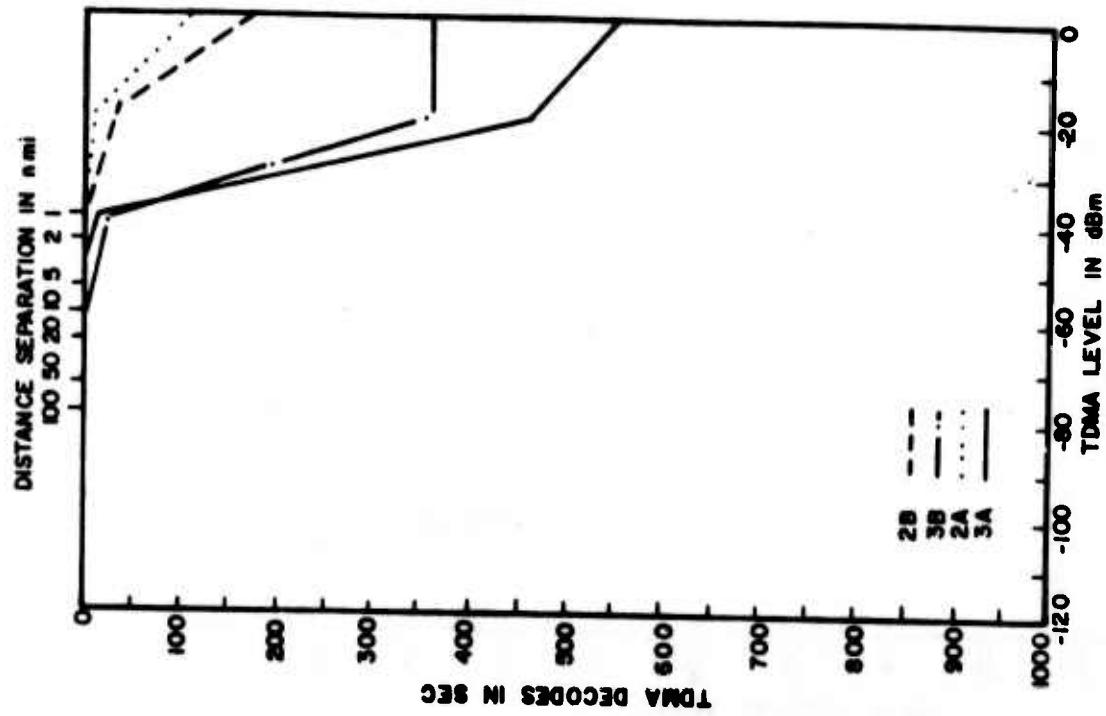

Figure C-9. Modified RTB-2 X mode beacon loading test results.

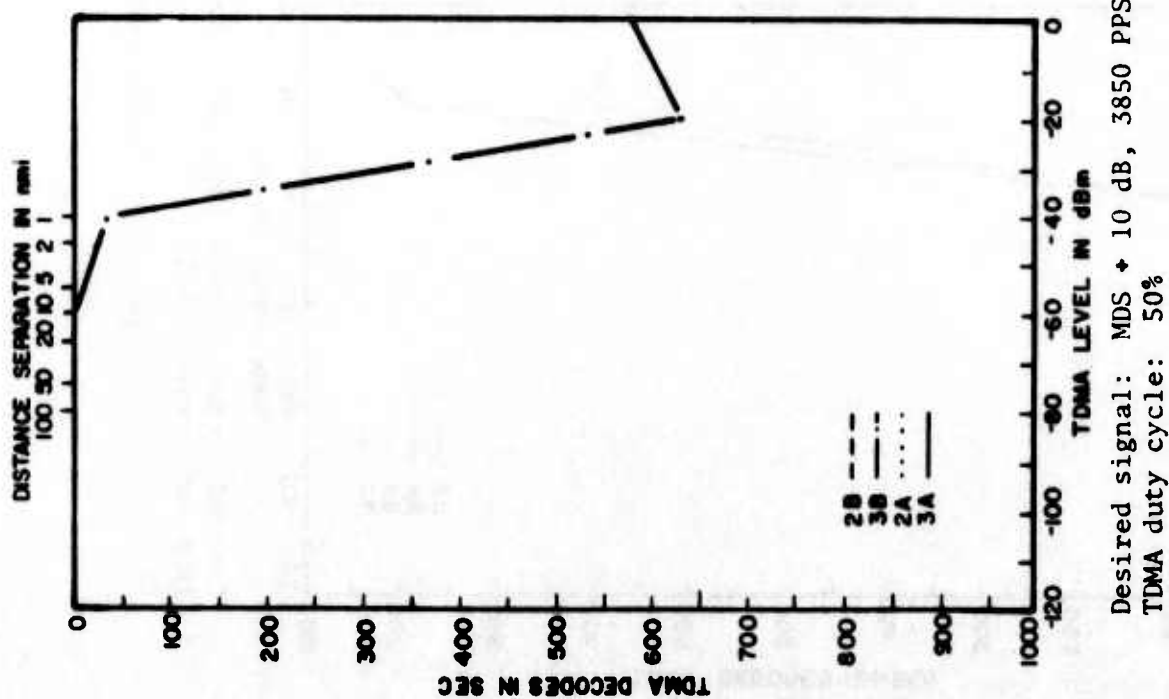
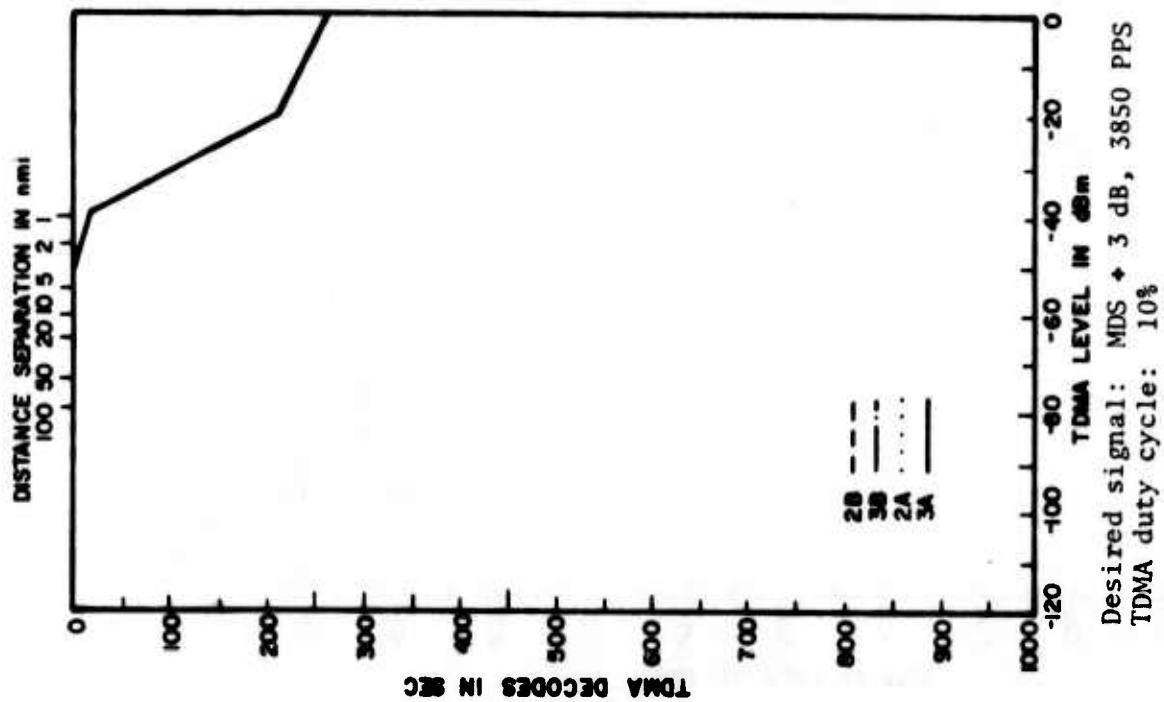
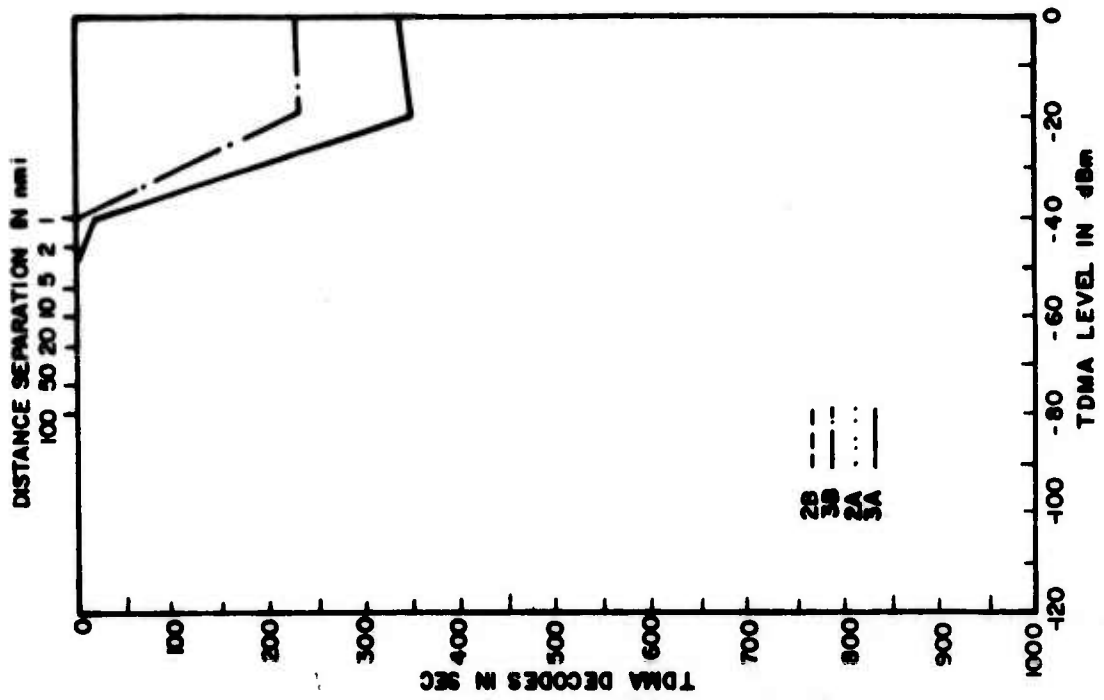
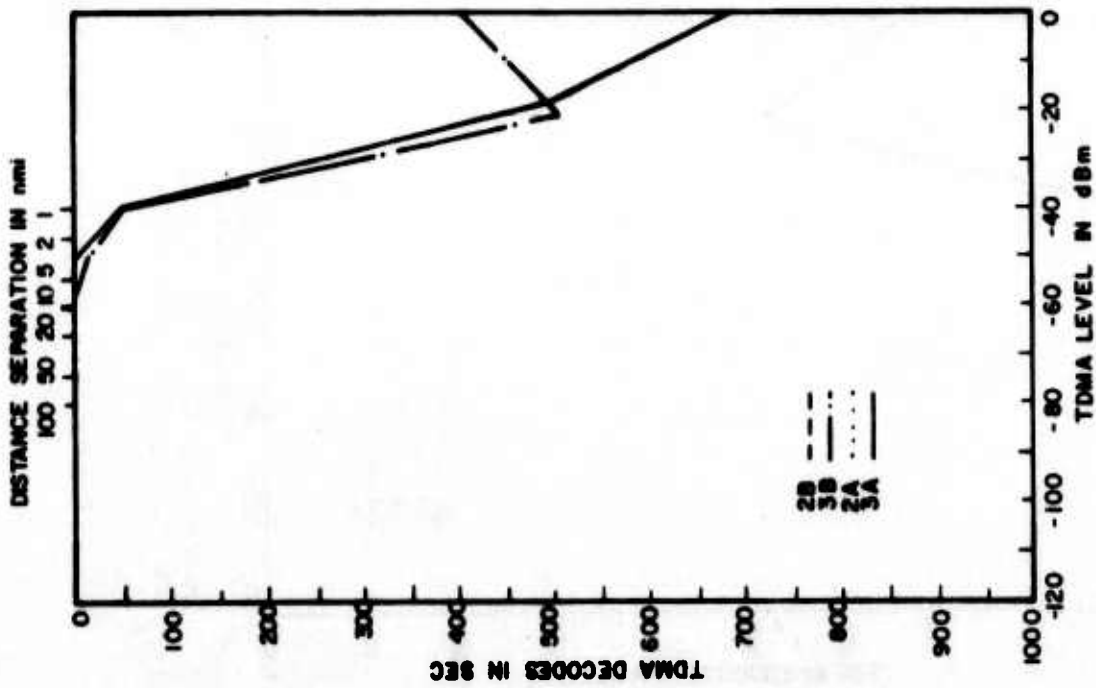

Figure C-10. Modified RTB-2 X mode beacon loading test results continued.



Desired signal: MDS + 3 dB, 3810 PPS  
TDMA duty cycle: 25%



Desired signal: MDS + 3 dB, 3810 PPS  
TDMA duty cycle: 50%

Figure C-11. Modified RTB-2 Y mode beacon loading test results.

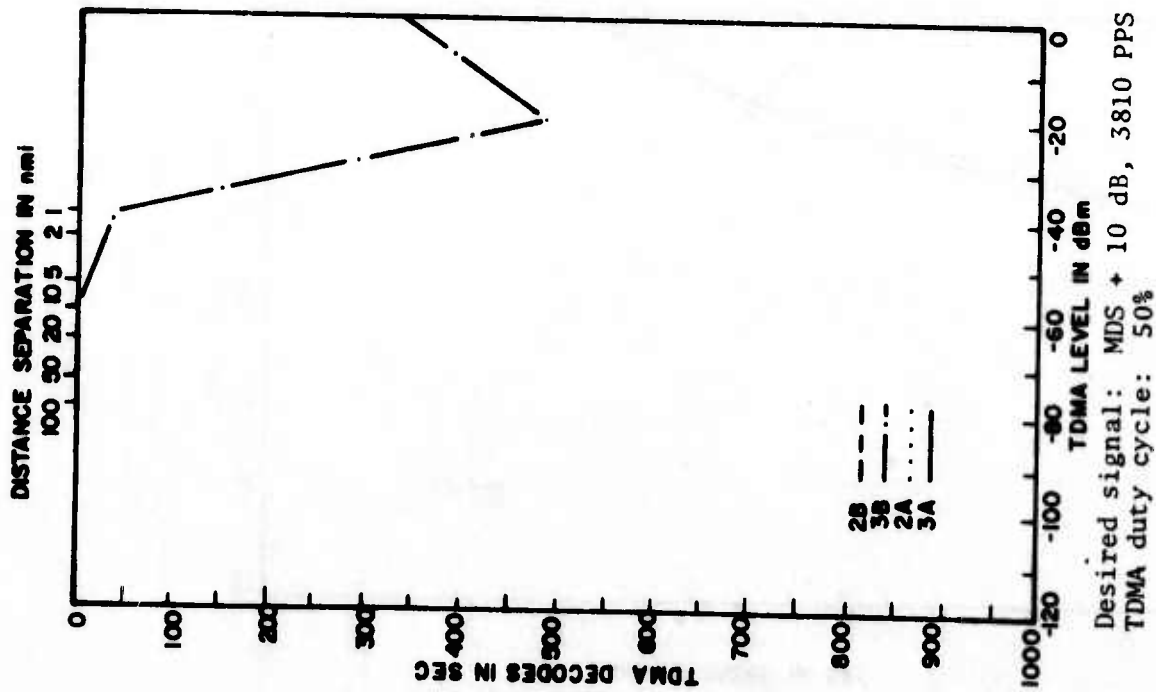
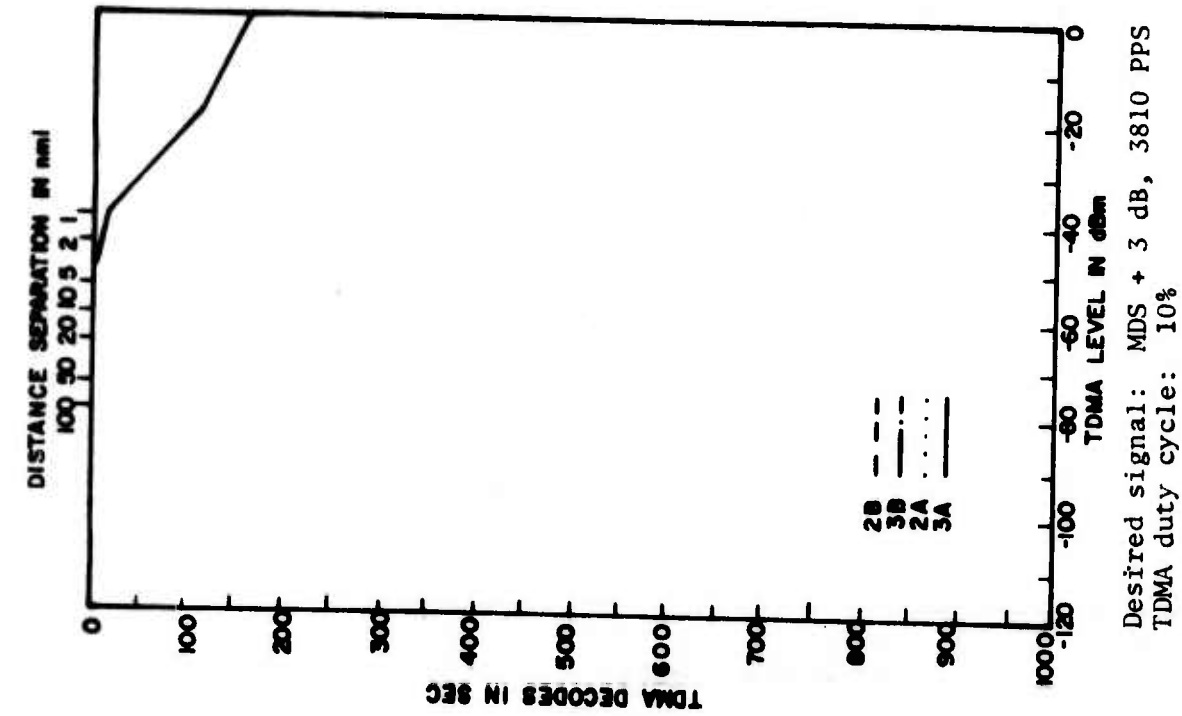

Figure C-12. Modified RTB-2 Y mode beacon loading test results continued.

APPENDIX D

TACAN/DME INTERROGATOR TEST RESULTS

In this appendix, the results of tests with seven different TACAN/DME interrogators are plotted. In the figures, the plotted values for channels 18X and 19X are for JTIDS narrowband signals, and those for channels 33X and 53Y are for wideband signals. The term "squit rate" is synonymous with reply rate.

CONTENTS

<u>Figure</u>	<u>Page</u>
D-1 King 7000 SN 1993 test results . . . . .	145
D-2 King 7000 SN 1993 test results continued . . . . .	146
D-3 King 7000 SN 2079 test results . . . . .	147
D-4 Collins 860-E2 test results . . . . .	148
D-5 Collins 860-E2 test results continued . . . . .	149
D-6 RCA AVQ-70 test results . . . . .	150
D-7 AN/ARN-21C test results (based on range acquire) . . . . .	151
D-8 AN/ARN-21C test results (based on azimuth acquire) . . . . .	152
D-9 NARCO 190 test results . . . . .	153
D-10 NARCO 190 test results continued . . . . .	154
D-11 NARCO UDI-4 test results . . . . .	155
D-12 King 705 test results . . . . .	156

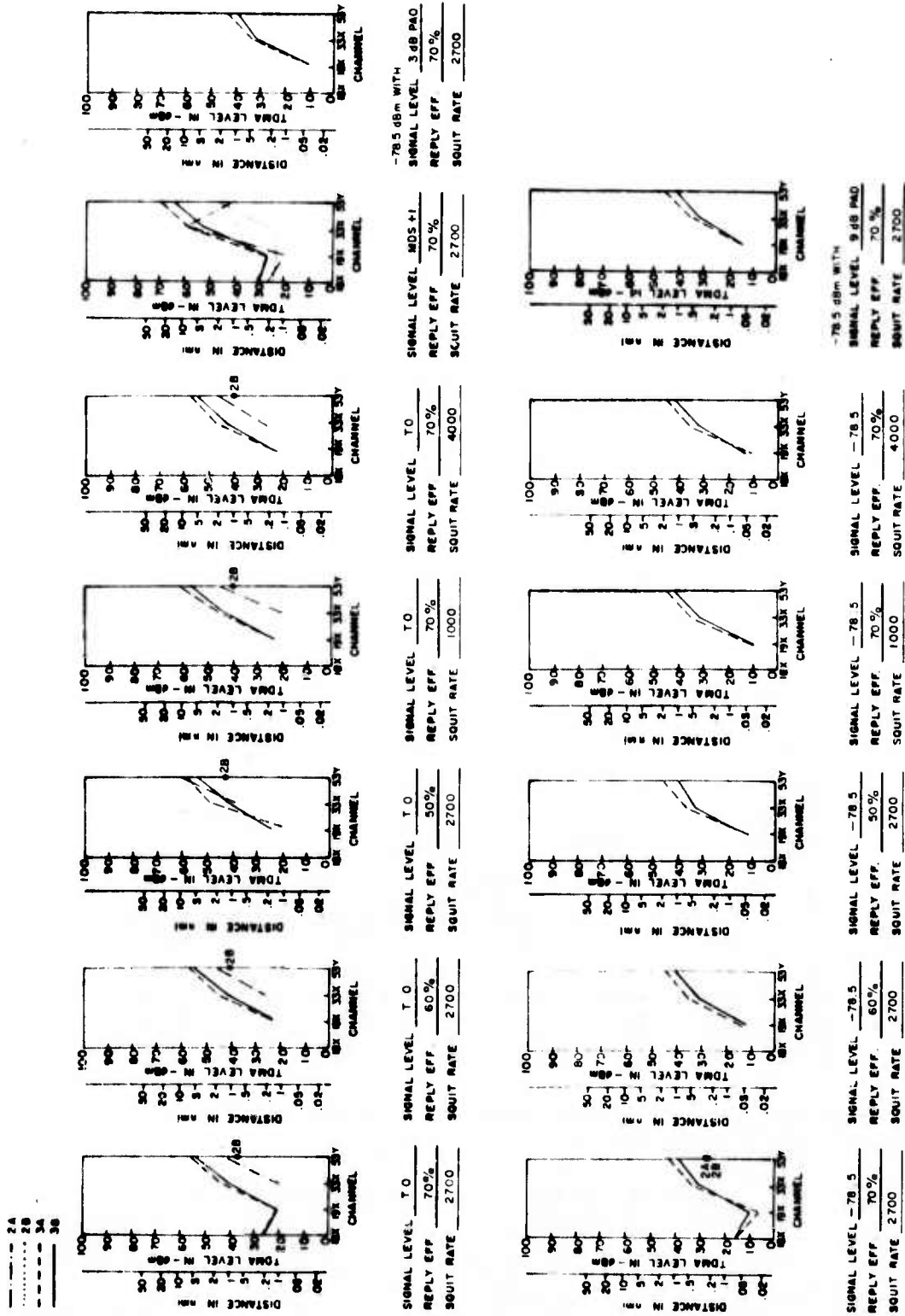

Note: MDS level varies with channel number. For MDS and T.O. levels, refer to TABLE 2, Section 3. Figure D-1. King 7000 SN 1993 test results, 50% duty factor.

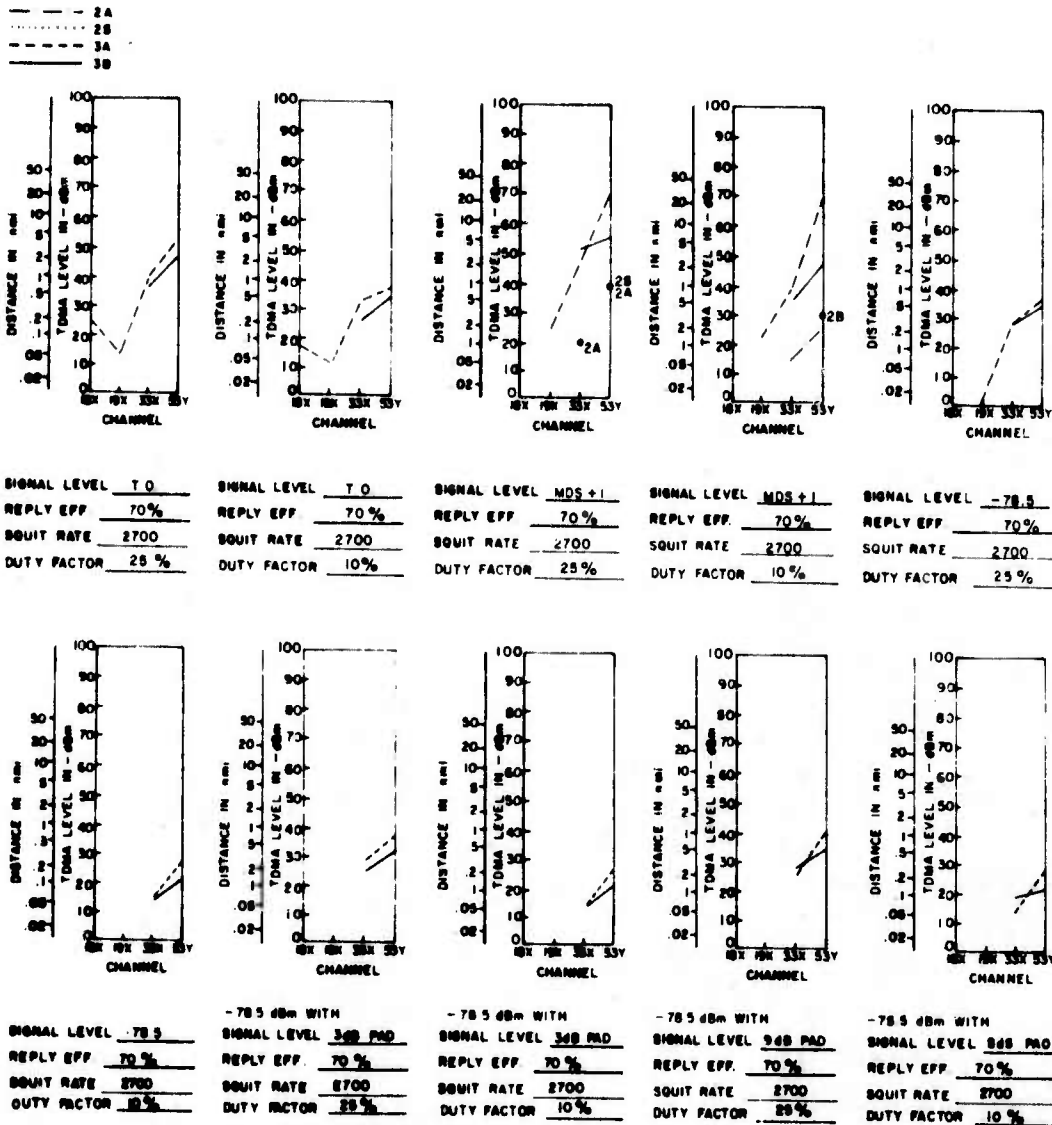

Note: MDS level varies with channel number. For MDS and T.O. levels, refer to TABLE 2, Section 3.

Figure D-2. King 7000 SN 1993 test results continued.

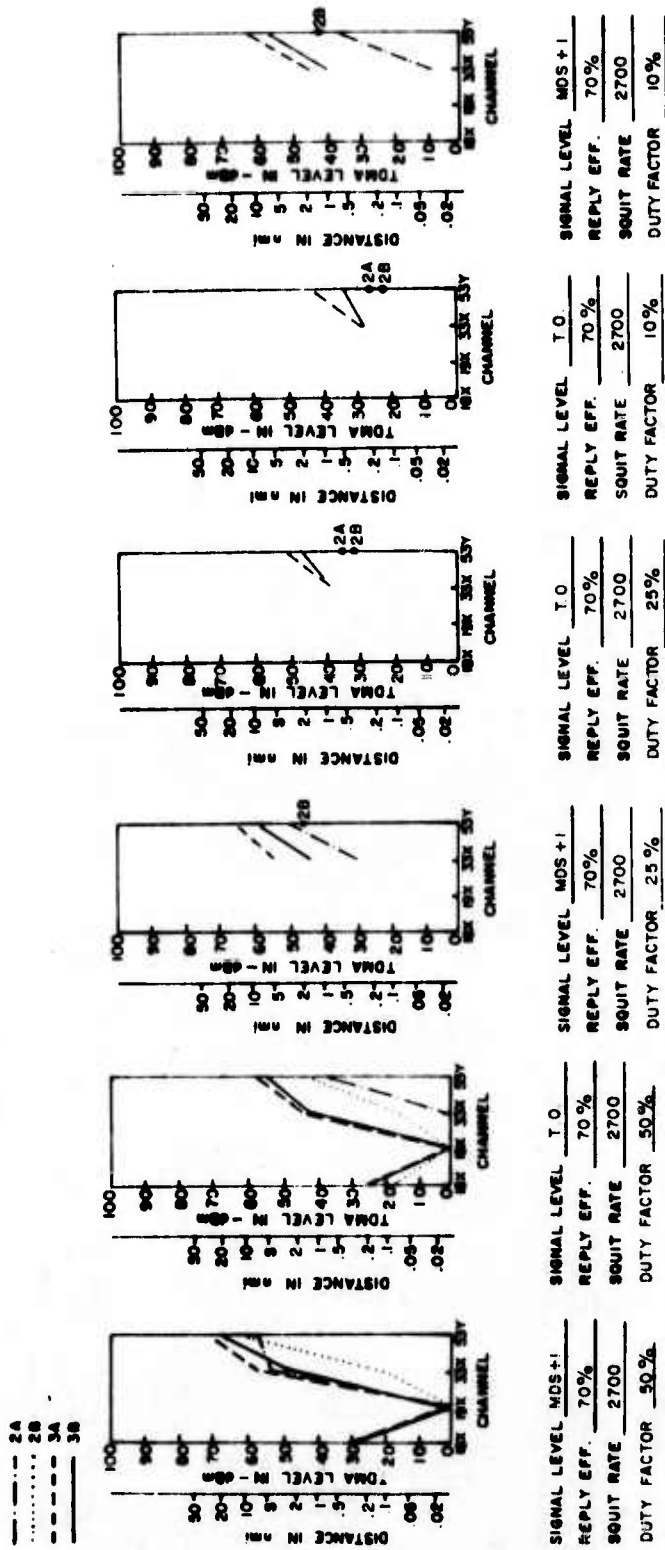

Note: MDS level varies with channel number. For MDS and T.O. levels, refer to TABLE 2, Section 3.

Figure D-3. King 7000 SN 2079 test results.

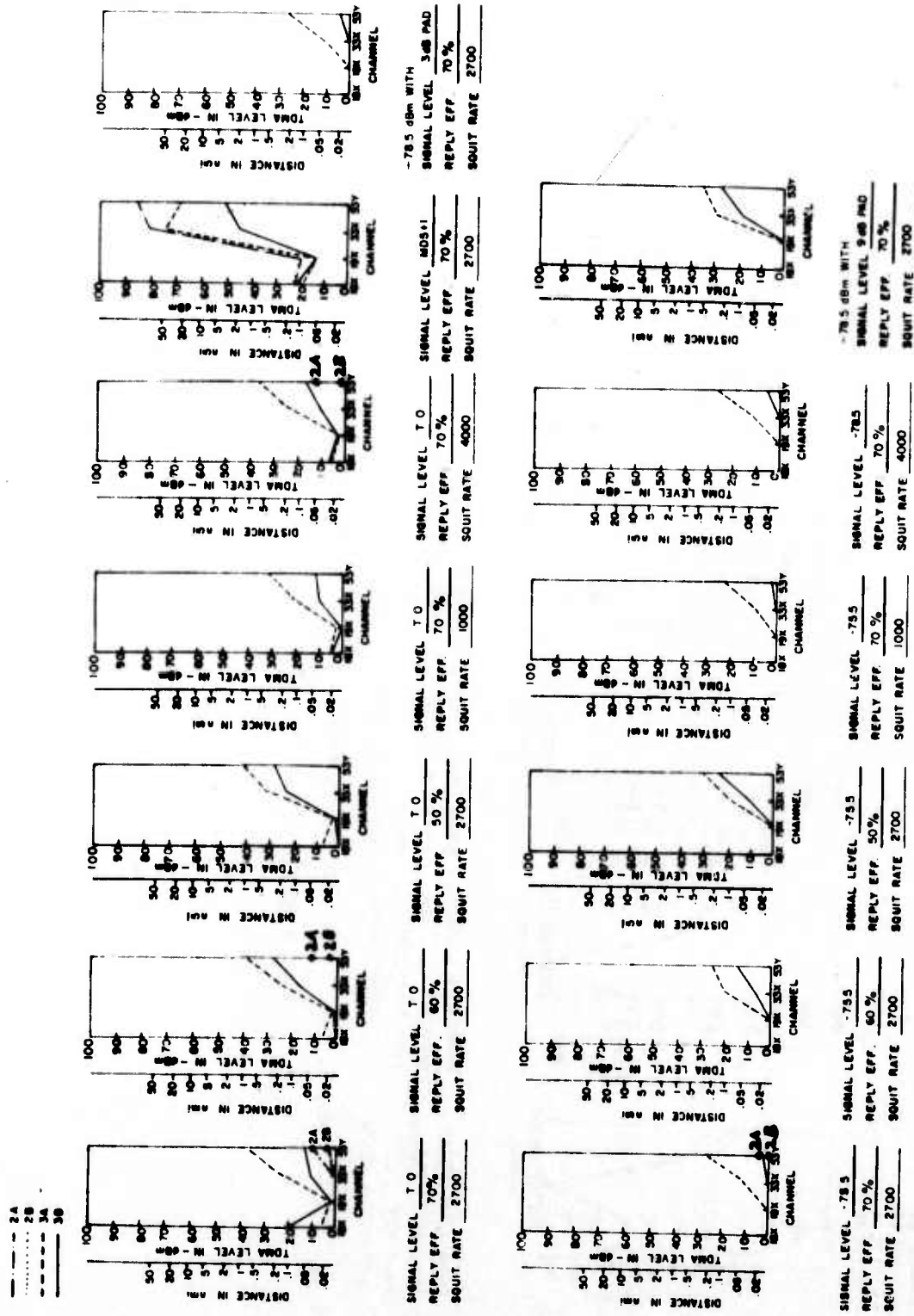

Note: MDS level varies with channel number. For MDS and T.O. levels, refer to TABLE 2, Section 3.  
 Figure D-4. Collins 860-E2 test results, 50% TDMA duty factor.

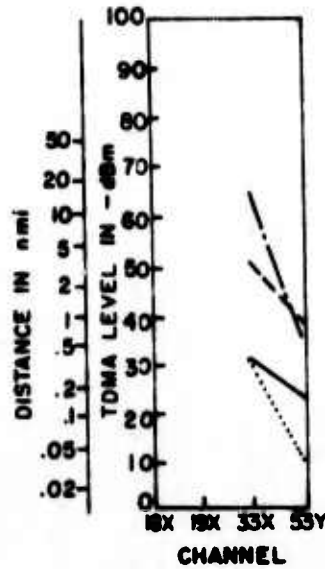
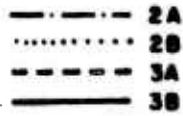

SIGNAL LEVEL MDS + 1  
 REPLY EFF. 70%  
 SQUIT RATE 2700  
 DUTY FACTOR 25%

SIGNAL LEVEL MDS + 1  
 REPLY EFF. 70%  
 SQUIT RATE 2700  
 DUTY FACTOR 10%

Note: MDS level varies with channel number. For MDS and T.O. levels, refer to TABLE 2, Section 3.

Figure D-5. Collins 860-E2 test results continued.

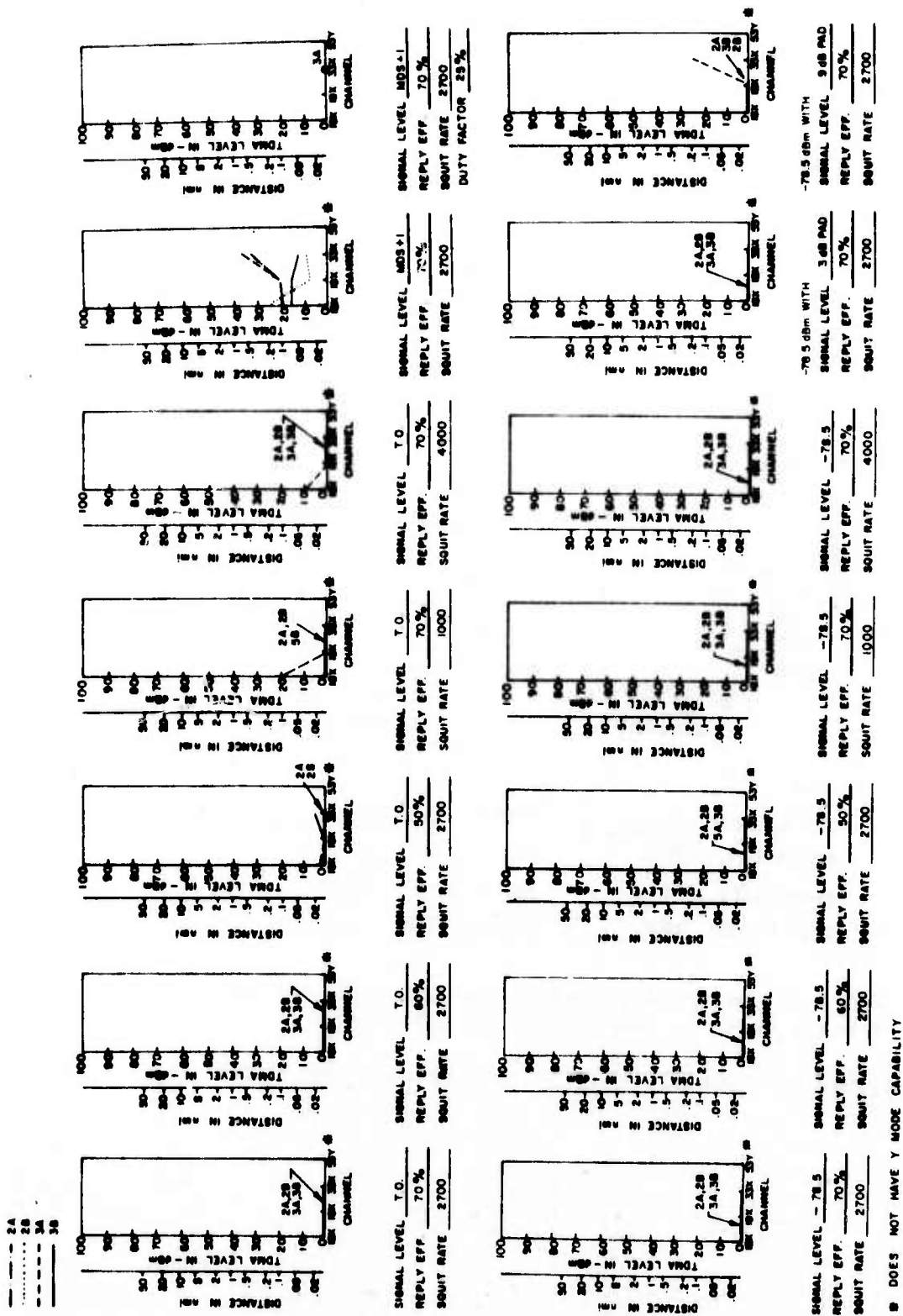

Note: MDS level varies with channel number. For MDS and T.O. levels, refer to TABLE 2, Section 3. Figure D-6. RCA AVQ-70 test results (50% duty factor, except where noted).

--- 2A  
 - - - 2B  
 - - - 3A  
 - - - 3B

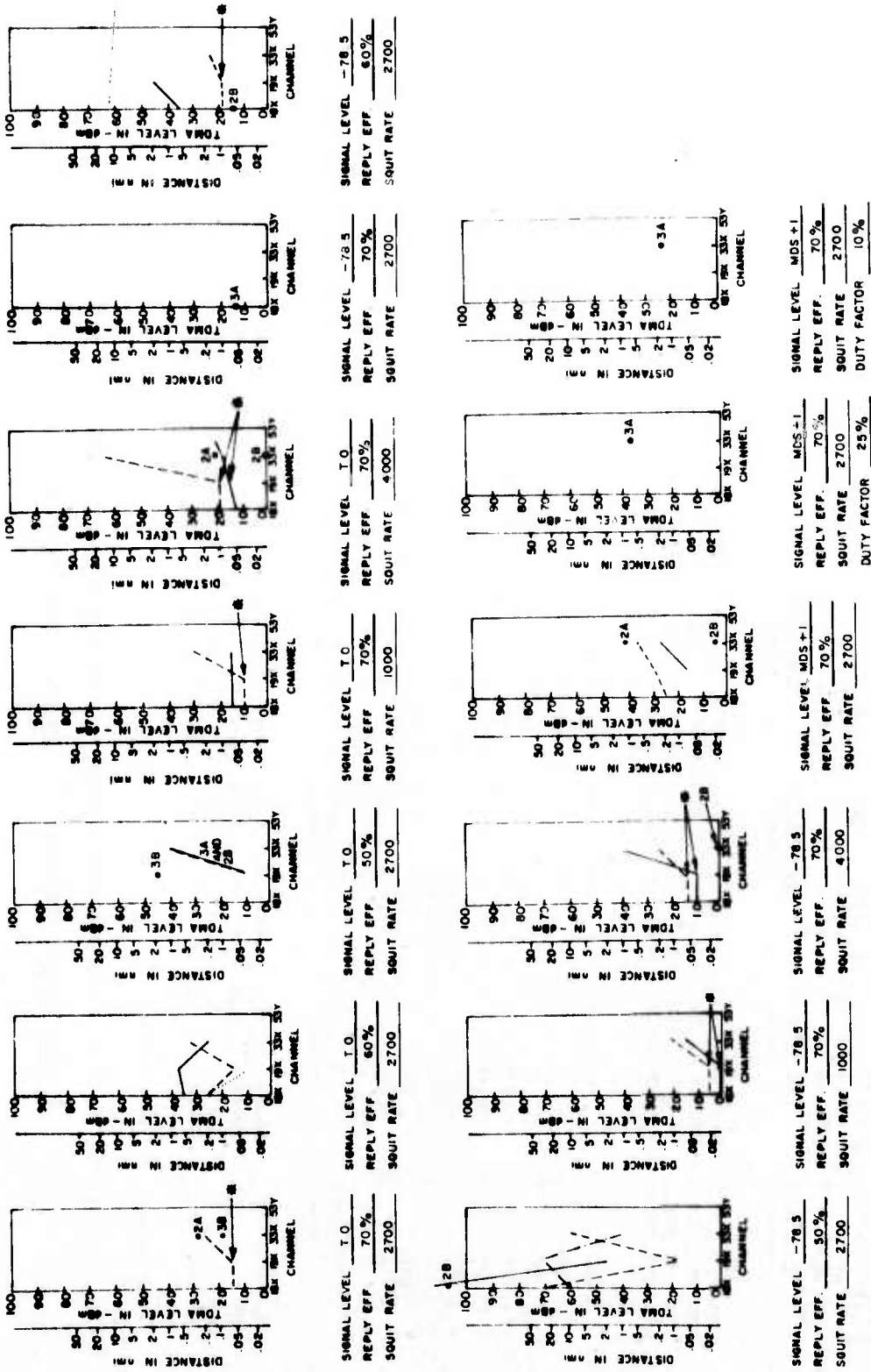

\* POINT FOR CHANNEL 19X WAS NOT TAKEN  
 NOTE DATA WAS PLOTTED FOR ACQUIRE RANGE ONLY

Note: MDS level varies with channel number. For MDS and T.O. levels, refer to TABLE 2, Section 3. Figure D-7. AN/ARN-21C test results, based on range acquire (50% duty factor, except where noted).

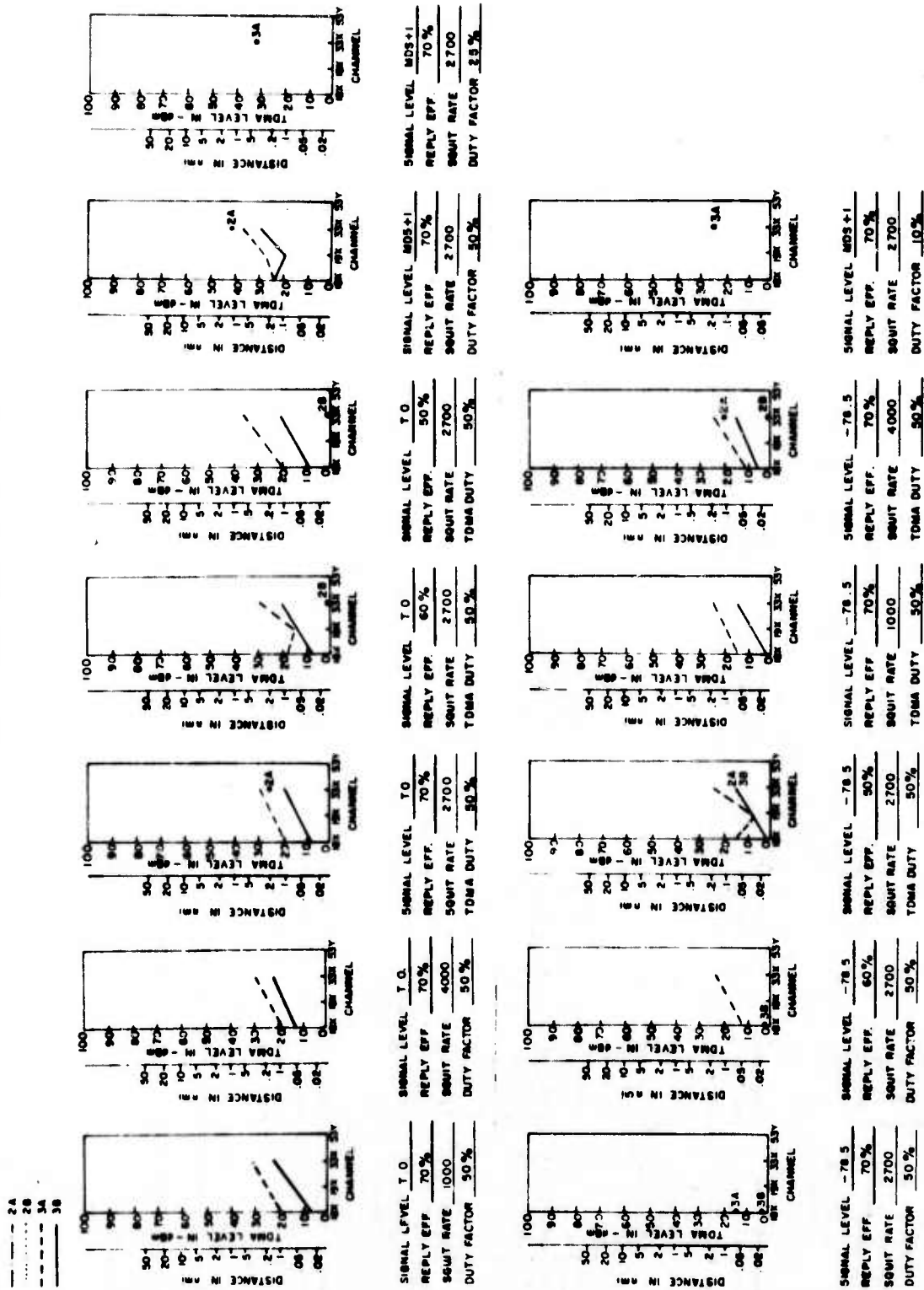

RESULTS PLOTTED FOR AZIMUTH ACQUIRE

Note: MDS level varies with channel number. For MDS and T.O. levels, refer to TABLE 2, Section 3. Figure D-8. AN/ARN-21C test results (based on azimuth acquire).

- 2A
- ..... 2B
- - - - 3A
- 3B

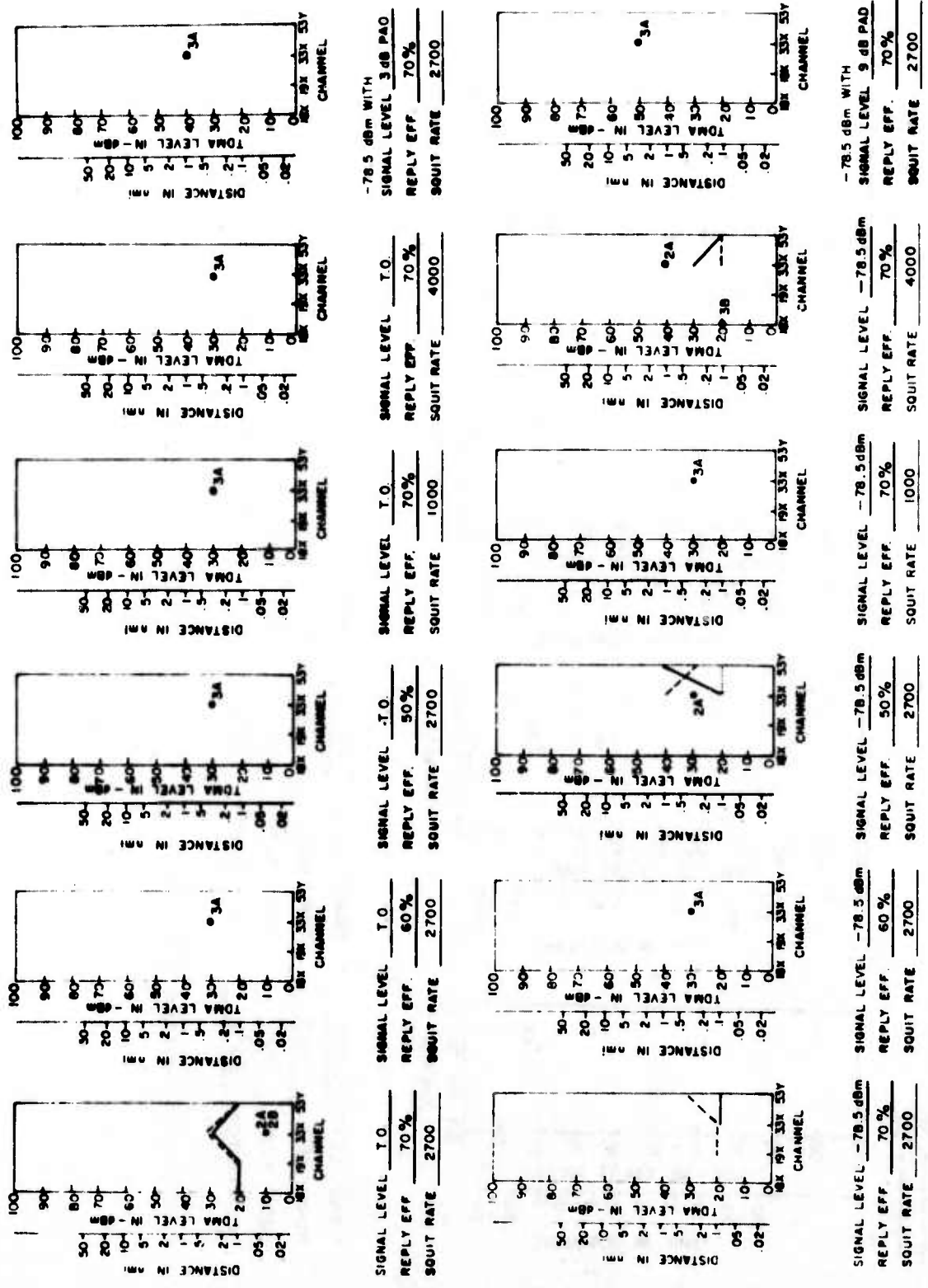

Note: MDS level varies with channel number. For MDS and T.O. levels, refer to TABLE 2, Section 3.  
 Figure D-9. NARCO 190 test results, 50% duty factor.

- 2A
- ..... 2B
- - - 3A
- 3B

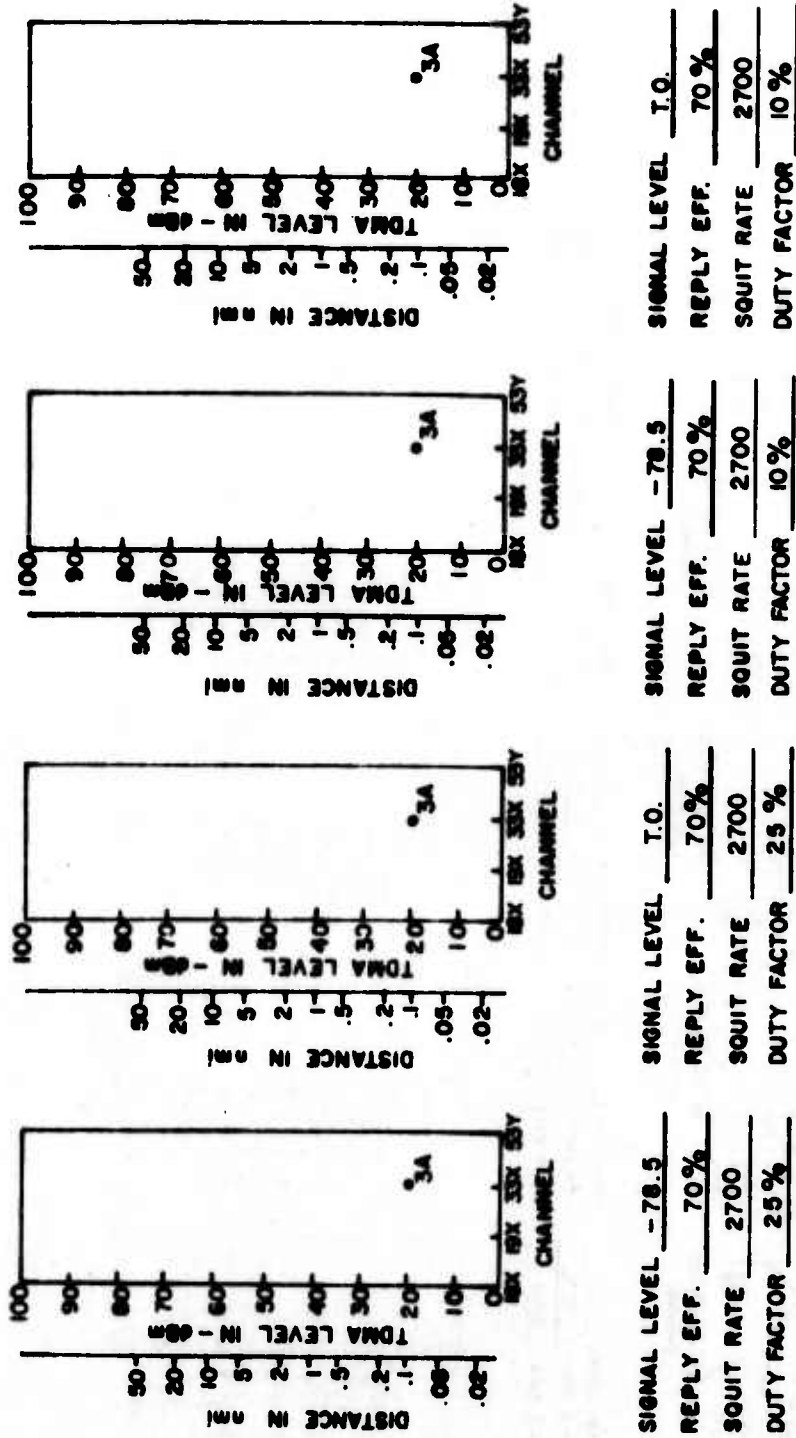

Note: MDS level varies with channel number. For MDS and T.O. levels, refer to TABLE 2, Section 3.  
 Figure D-10. NARCO 190 test results continued.

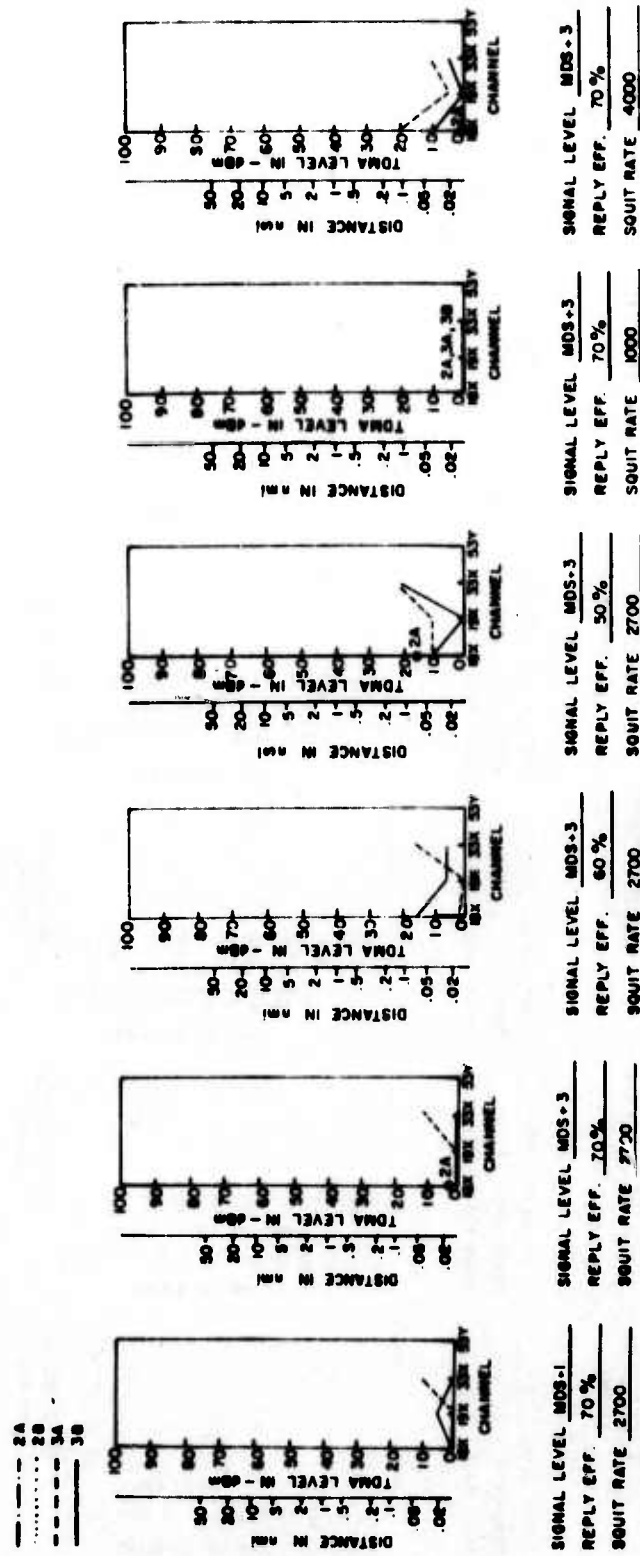

DEFINITION OF ACQUIRE: ONCE IN 30 SECONDS

Note: MDS level varies with channel number. For MDS and T.O. levels, refer to TABLE 2, Section 5.

Figure D-11. NARCO UDI-4 test results, 50% duty factor.

- 2A
- 2B
- 3A
- 3B



Note: MDS level varies with channel number. For MDS and T.O. levels, refer to TABLE 2, Section 3. Figure D-12. King 705 test results (50% duty factor, except where noted).

APPENDIX E

DIGITAL DATA BROADCAST TEST RESULTS

CONTENTS

<u>Figure</u>	<u>Page</u>
E-1 Digital data broadcast test results for desired signal level of MDS + 2 dB and wideband TDMA duty factor of 50% . . . . .	159
E-2 Digital data broadcast test results for desired signal level of MDS + 2 dB and narrowband TDMA duty factor of 50% . . . . .	160
E-3 Digital data broadcast test results for desired signal level of MDS + 2 dB and wideband TDMA duty factor of 25% . . . . .	161
E-4 Digital data broadcast test results for desired signal level of MDS + 4 dB and wideband TDMA duty factor of 50% . . . . .	162
E-5 Digital data broadcast test results for desired signal level of MDS + 4 dB and narrowband TDMA duty factor of 50% . . . . .	163
E-6 Digital data broadcast test results for desired signal level of MDS + 4 dB and wideband TDMA duty factor of 25% . . . . .	164
E-7 Digital data broadcast test results for desired signal level of MDS + 4 dB and narrowband TDMA duty factor of 25% . . . . .	165
E-8 Digital data broadcast test results for desired signal level of MDS + 6 dB and wideband TDMA duty factor of 50% . . . . .	166
E-9 Digital data broadcast test results for desired signal level of MDS + 6 dB and narrowband TDMA duty factor of 50% . . . . .	167
E-10 Digital data broadcast test results for desired signal level of MDS + 6 dB and wideband TDMA duty factor of 25% . . . . .	168
E-11 Digital data broadcast test results for desired signal level of MDS + 6 dB and narrowband TDMA duty factor of 25% . . . . .	169
E-12 Digital data broadcast test results for desired signal level of MDS + 10 dB and wideband TDMA duty factor of 50% . . . . .	170
E-13 Digital data broadcast test results for desired signal level of MDS + 10 dB and narrowband TDMA duty factor of 25% . . . . .	171
E-14 Digital data broadcast test results for desired signal level of MDS + 10 dB and wideband TDMA duty factor of 25% . . . . .	172

APPENDIX E  
DIGITAL DATA BROADCAST TEST RESULTS  
CONTENTS (Cont'd)

<u>Figure</u>	<u>Page</u>
E-15 Digital data broadcast test results for desired signal level of MDS + 10 dB and narrowband TDMA duty factor of 50% . . . . .	173
E-16 Digital data broadcast spurious decode test results for desired signal level of MDS + 2 dB and wide and narrowband TDMA duty factor of 50% . . . . .	174
E-17 Digital data broadcast spurious decode test results for desired signal level of MDS + 10 dB and wide and narrowband TDMA duty factor of 50% . . . . .	175

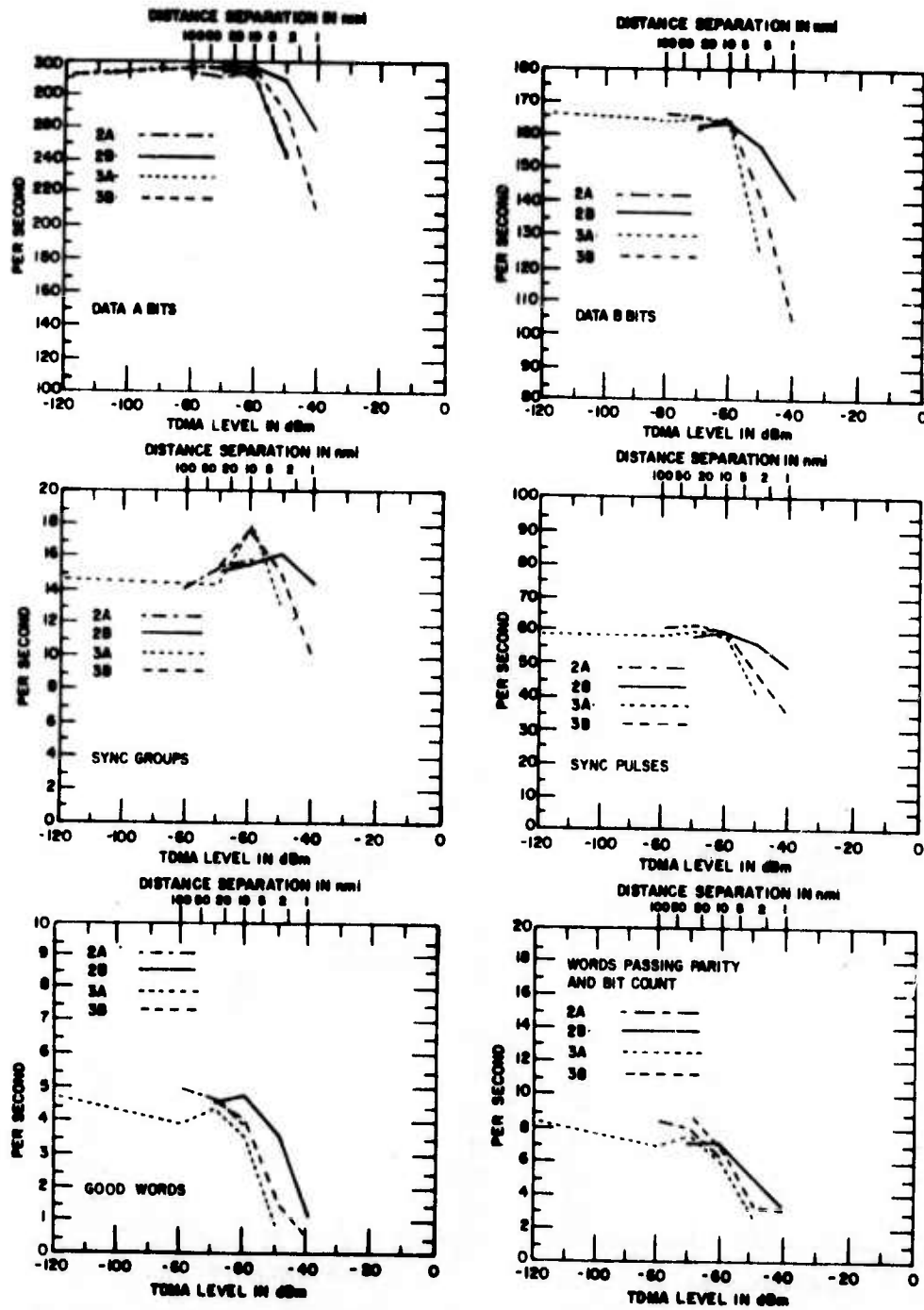

Figure E-1. Digital data broadcast test results for desired signal level of MDS + 2 dB and wideband TDMA duty factor of 50%.

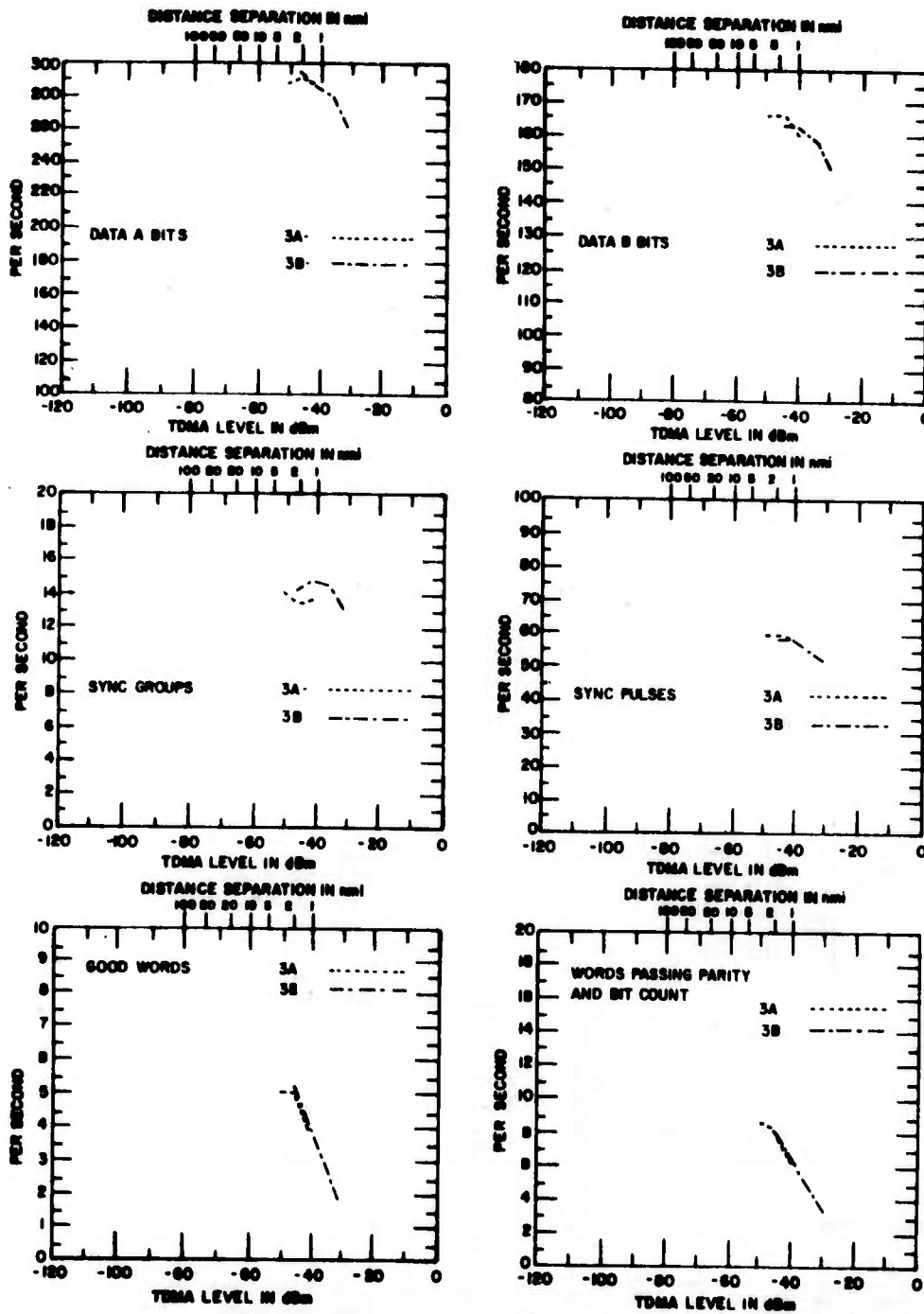

Figure E-2. Digital data broadcast test results for desired signal level of MDS + 2 dB and narrowband TDMA duty factor of 50%.

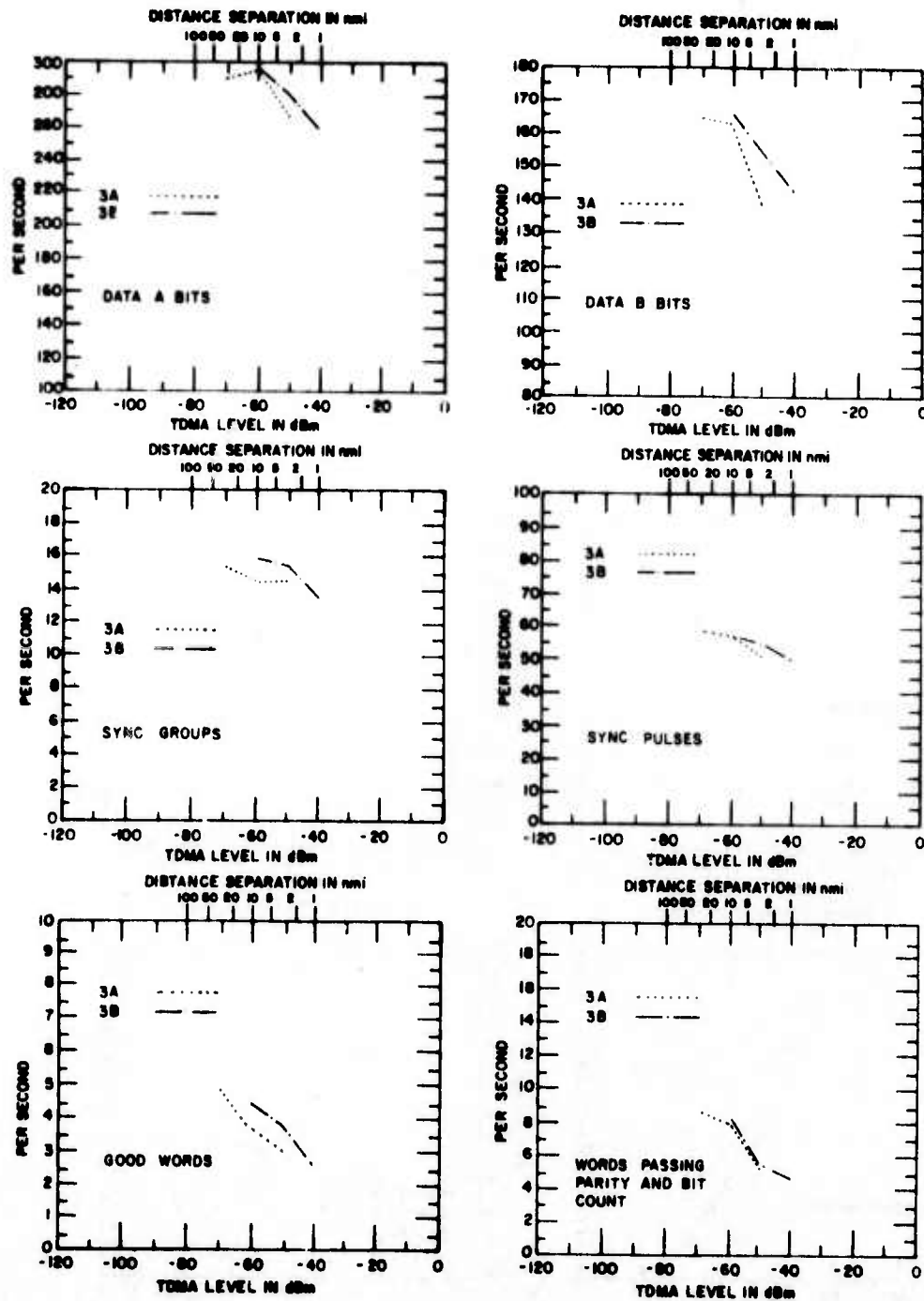

Figure E-3. Digital data broadcast test results for desired signal level of MDS + 2 dB and wideband TDMA duty factor of 25%.

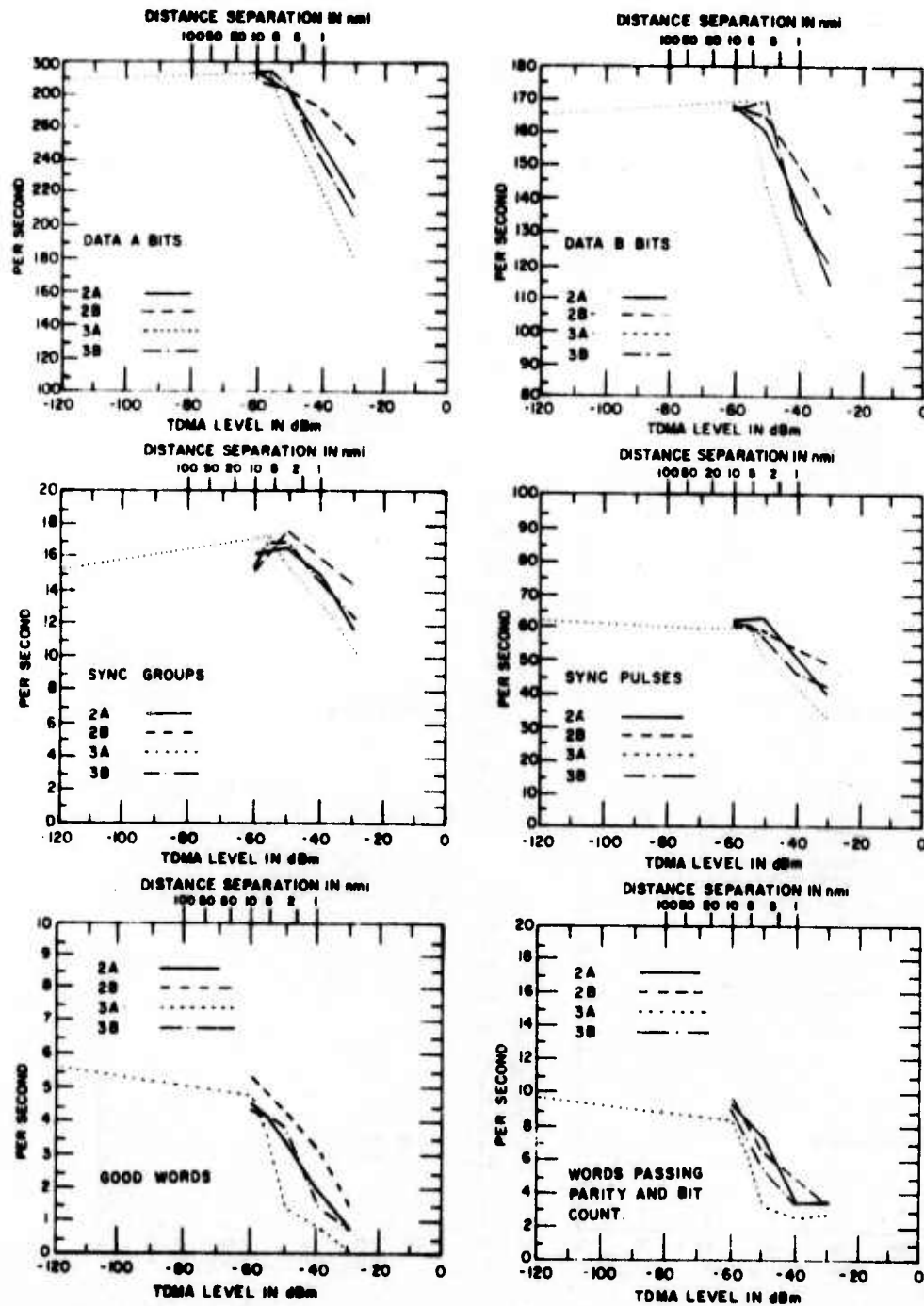

Figure E-4. Digital data broadcast test results for desired signal level of MDS + 4 dB and wideband TDMA duty factor of 50%.

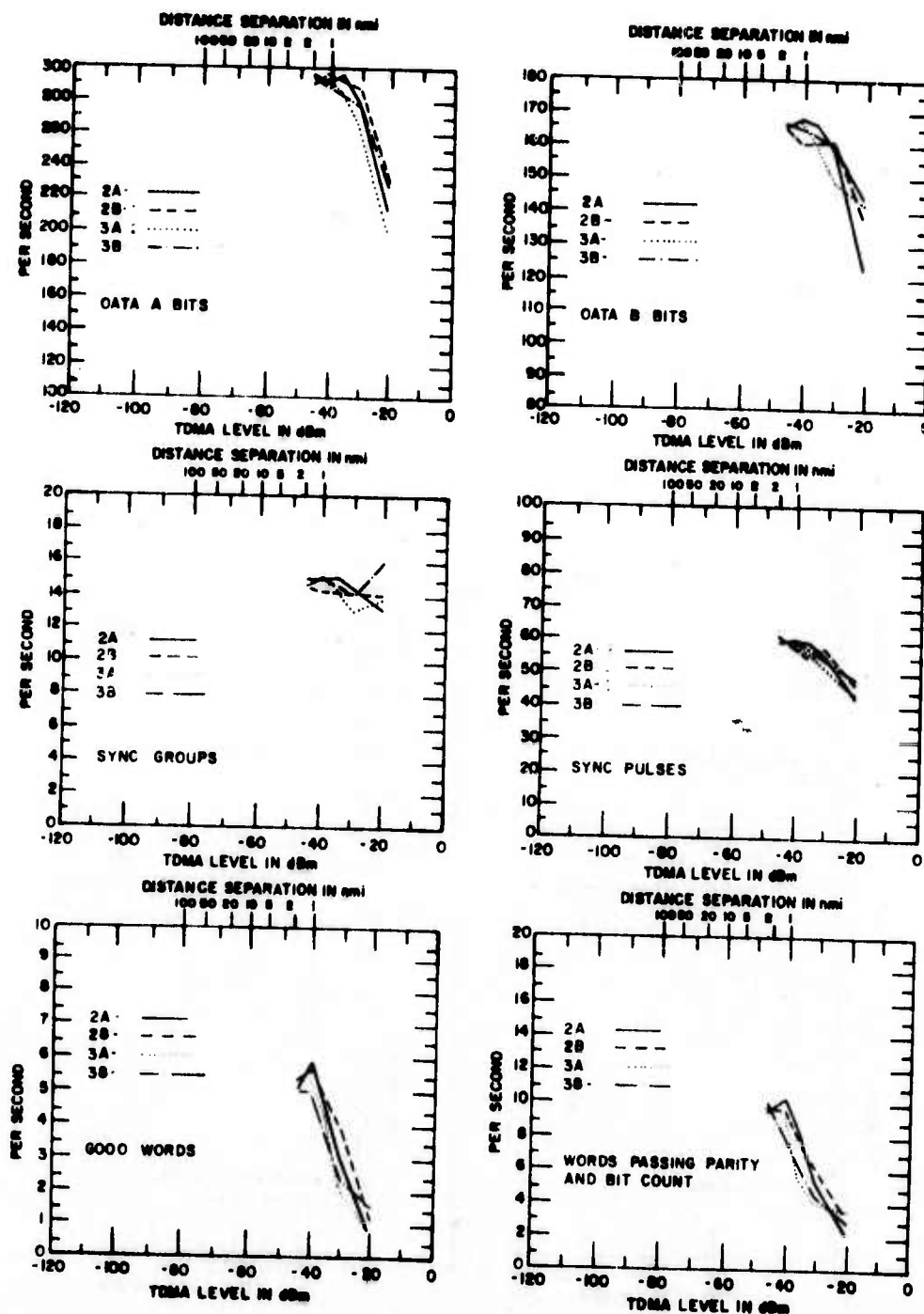

Figure E-5. Digital data broadcast test results for desired signal level of MDS + 4 dB and narrowband TDMA duty factor of 50%.

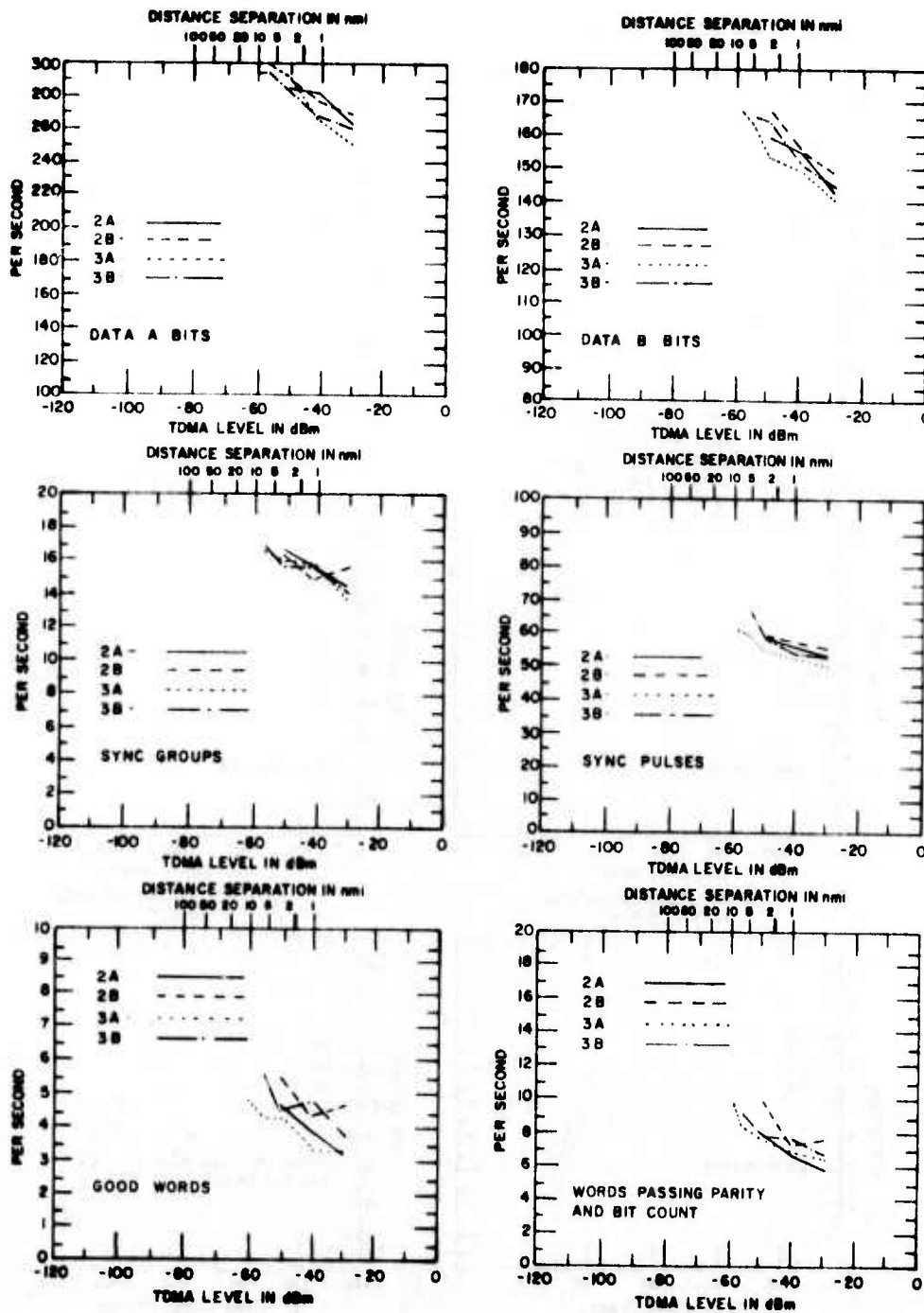

Figure E-6. Digital data broadcast test results for desired signal level of MDS + 4 dB and wideband TDMA duty factor of 50%.

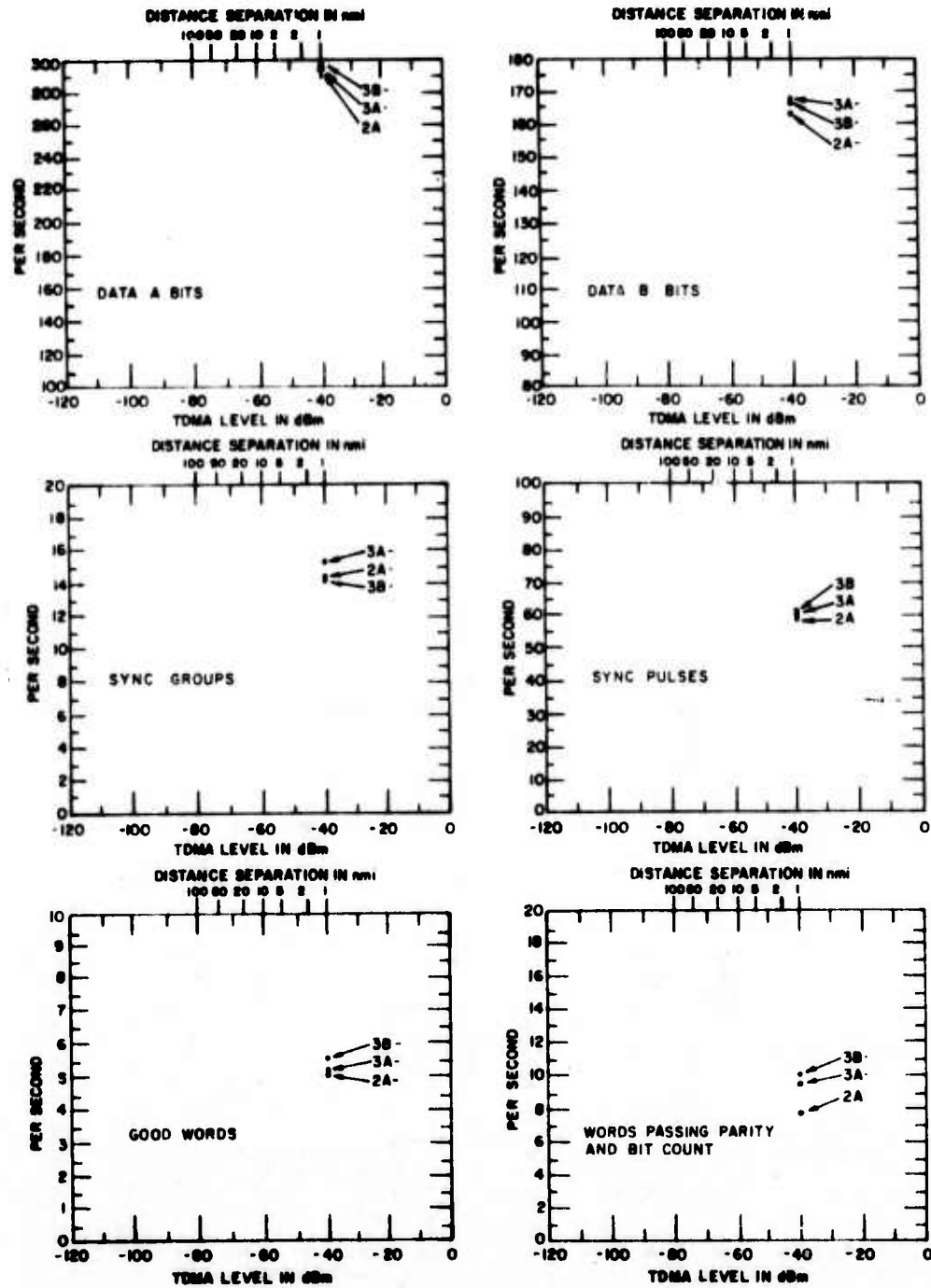

Figure E-7. Digital data broadcast test results for desired signal level of MDS + 4 dB and narrowband TDMA duty factor of 25%.

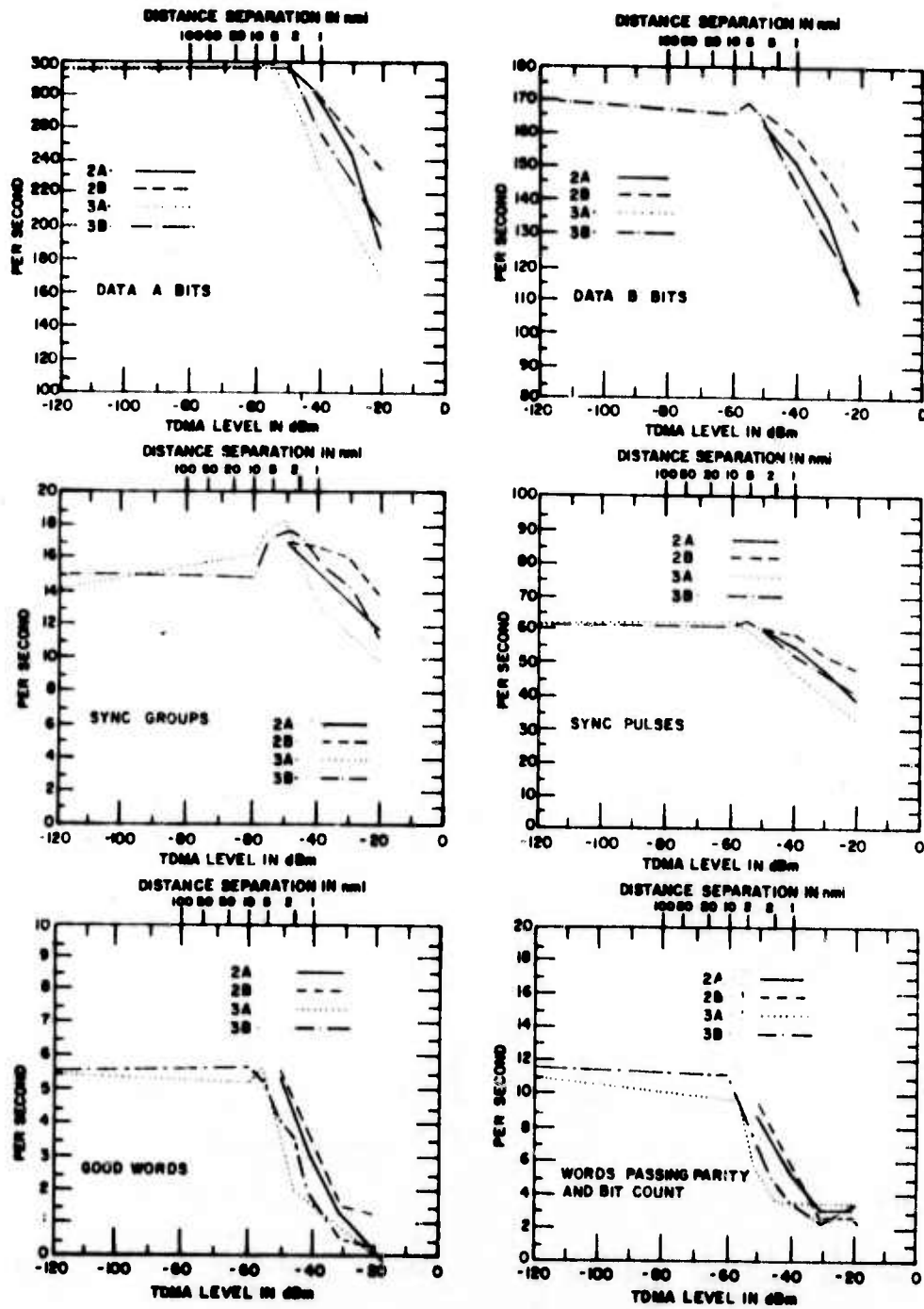

Figure E-8. Digital data broadcast test results for desired signal level of MDS + 6 dB and wideband TDMA duty factor of 50%.

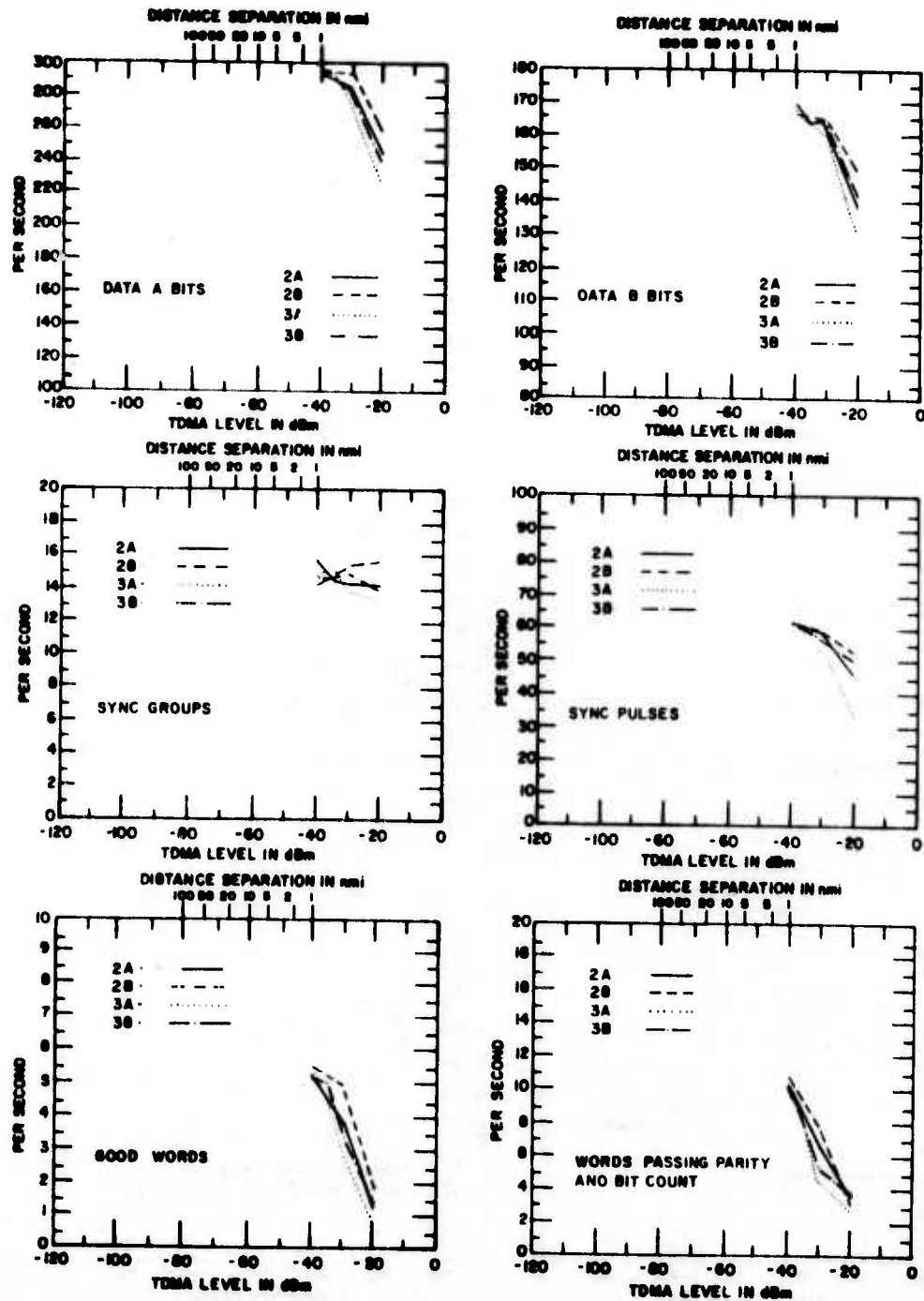

Figure E-9. Digital data broadcast test results for desired signal level of MDS + 6 dB and narrowband TDMA duty factor of 50%.

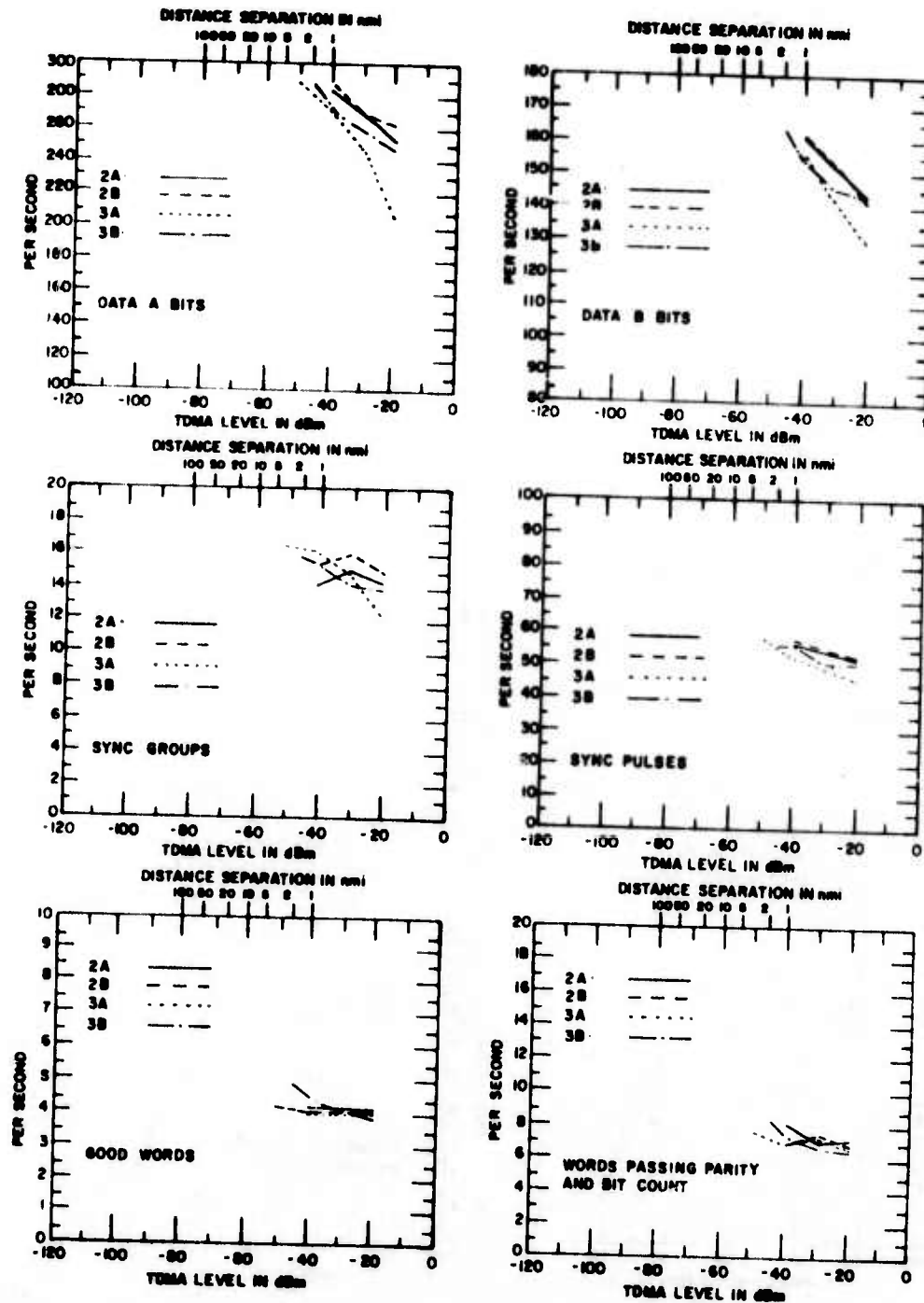

Figure E-10. Digital data broadcast test results for desired signal level of MDS + 6 dB and wideband TDMA duty factor of 25%.

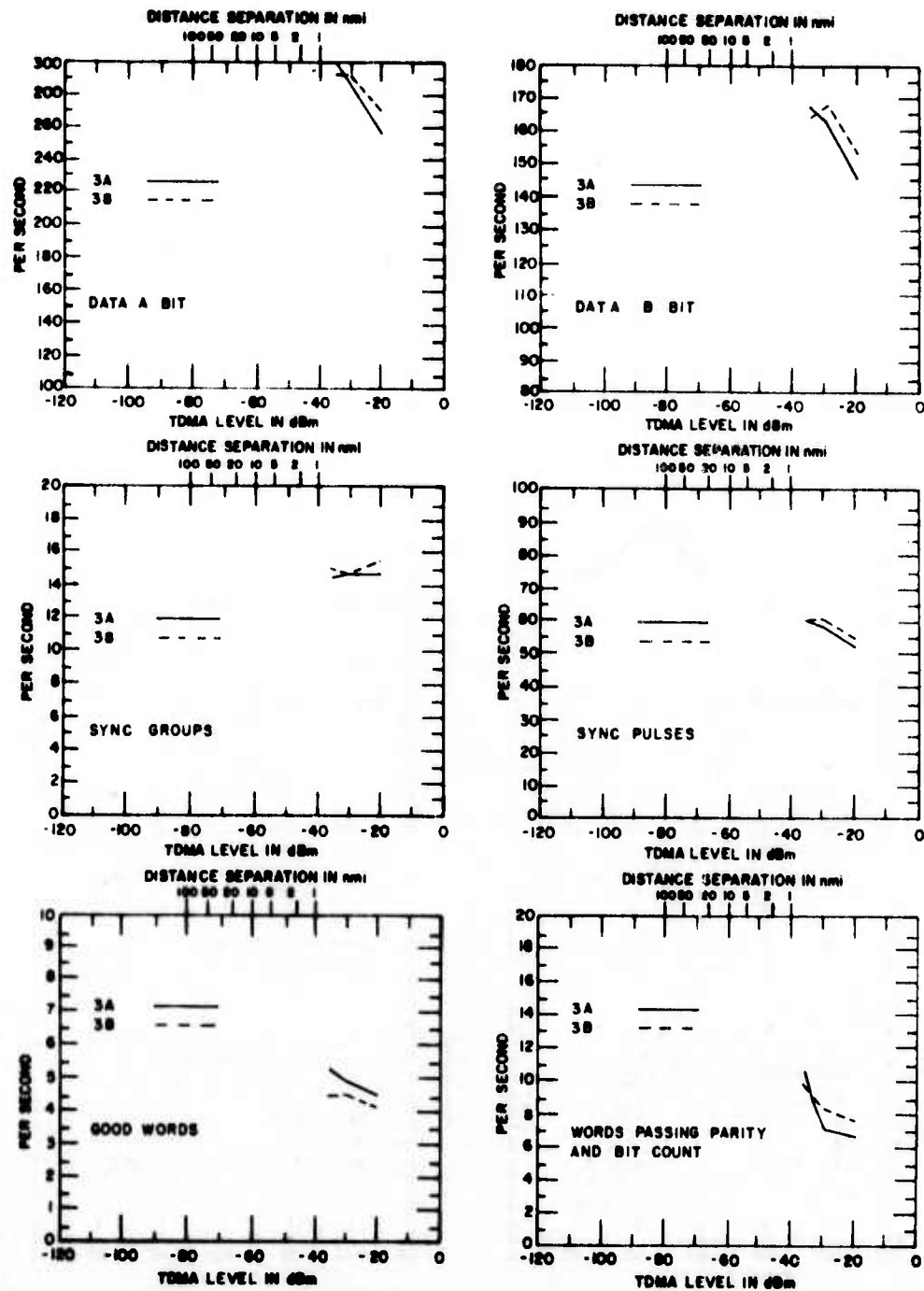

Figure E-11. Digital data broadcast test results for desired signal level of MDS + 6 dB and narrowband TDMA duty factor of 25%.

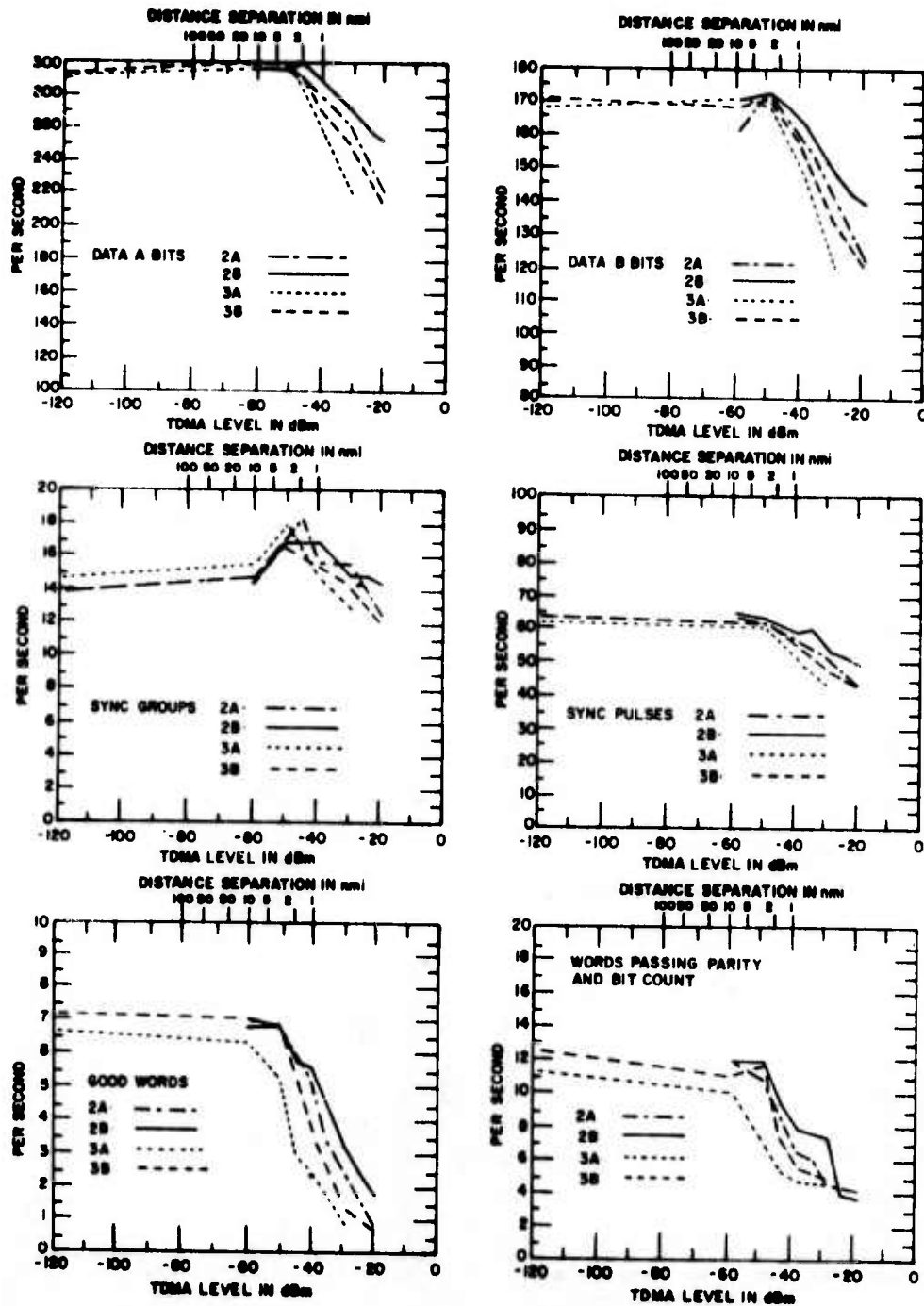

Figure E-12. Digital data broadcast test results for desired signal level of MDS + 10 dB and wideband TDMA duty factor of 50%.

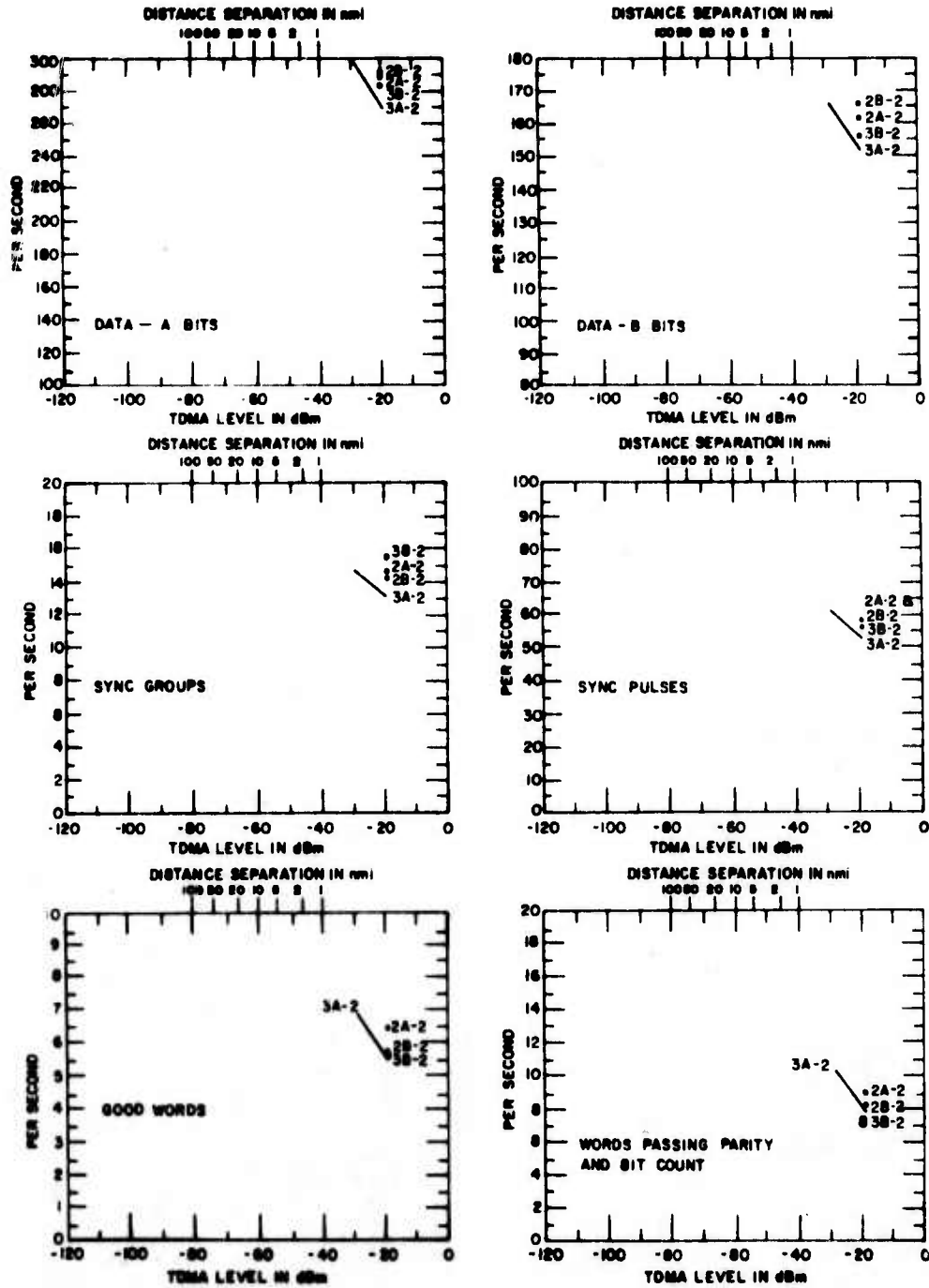

Figure E-13. Digital data broadcast test results for desired signal level of MDS + 10 dB and narrowband TDMA duty factor of 25%.

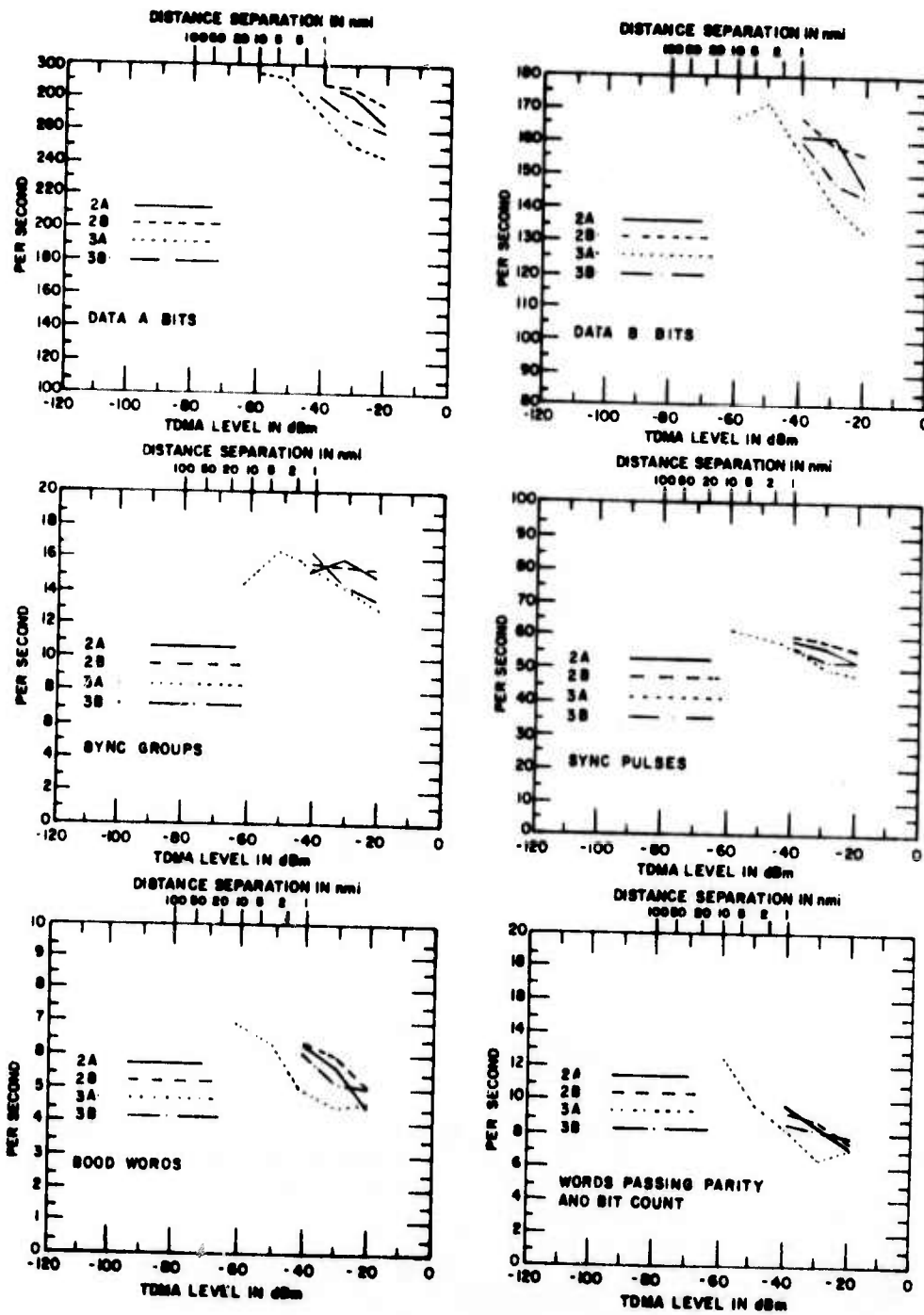

Figure E-14. Digital data broadcast test results for desired signal level of MDS + 10 dB and wideband TDMA duty factor of 25%.

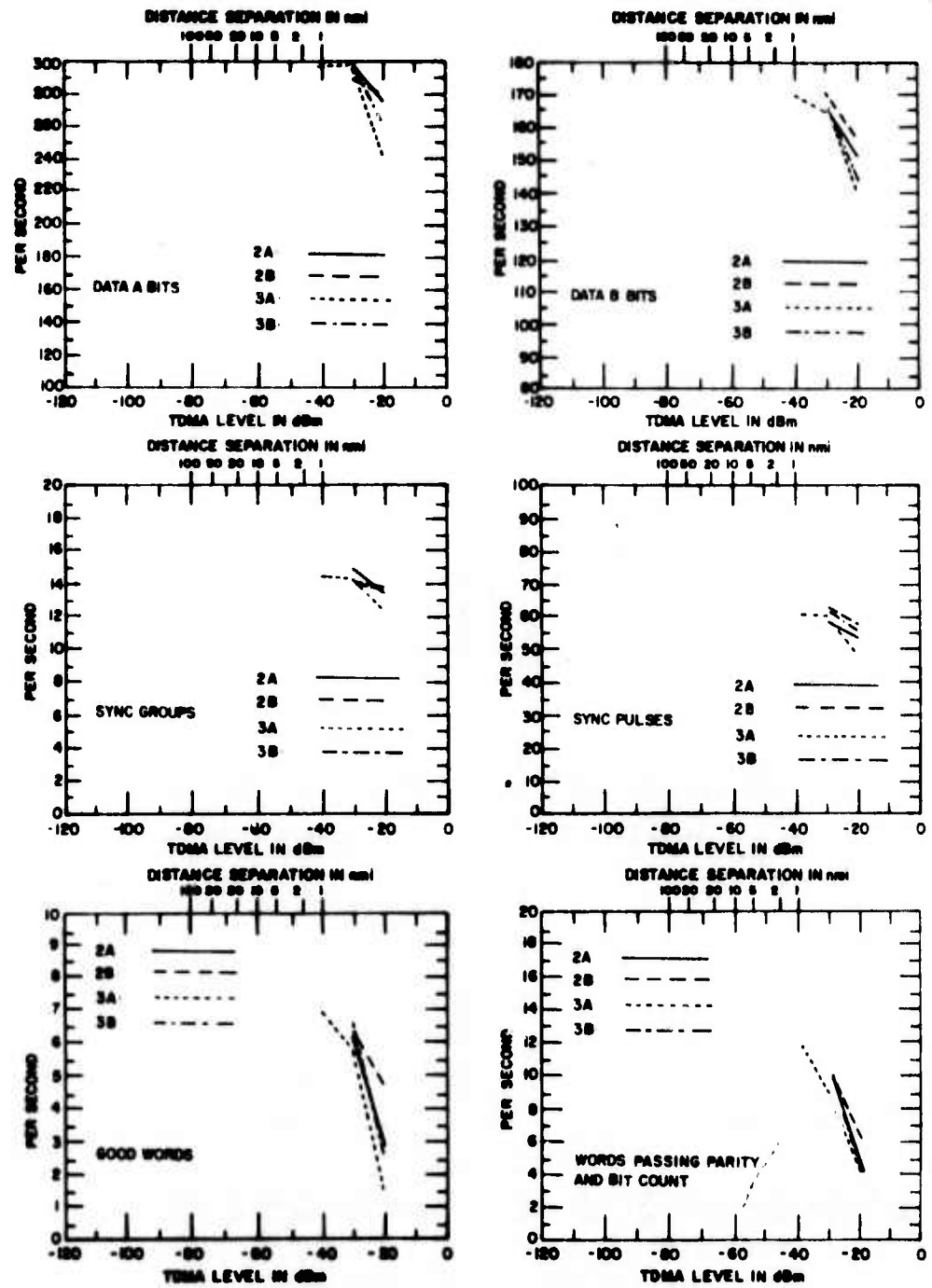
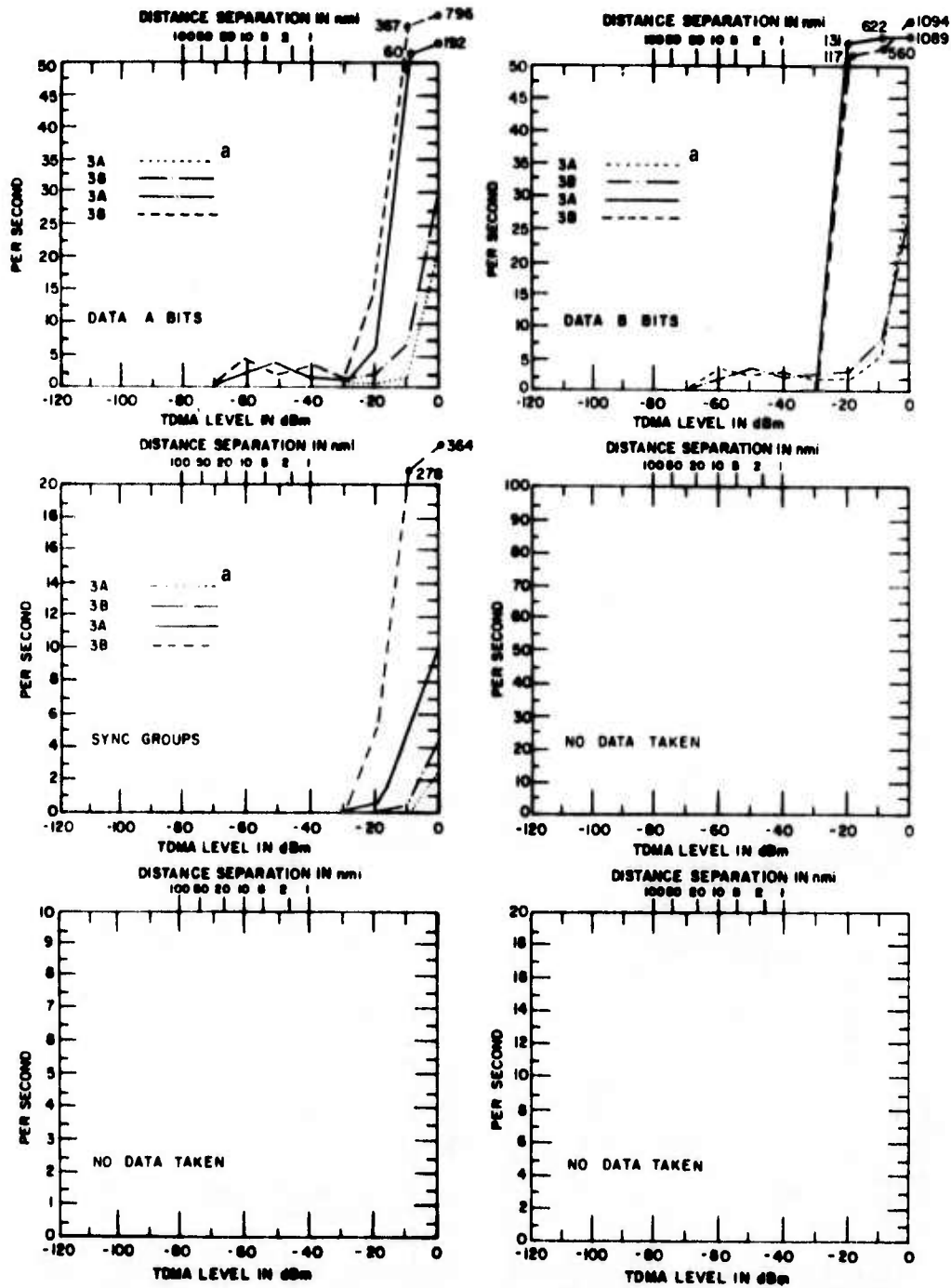
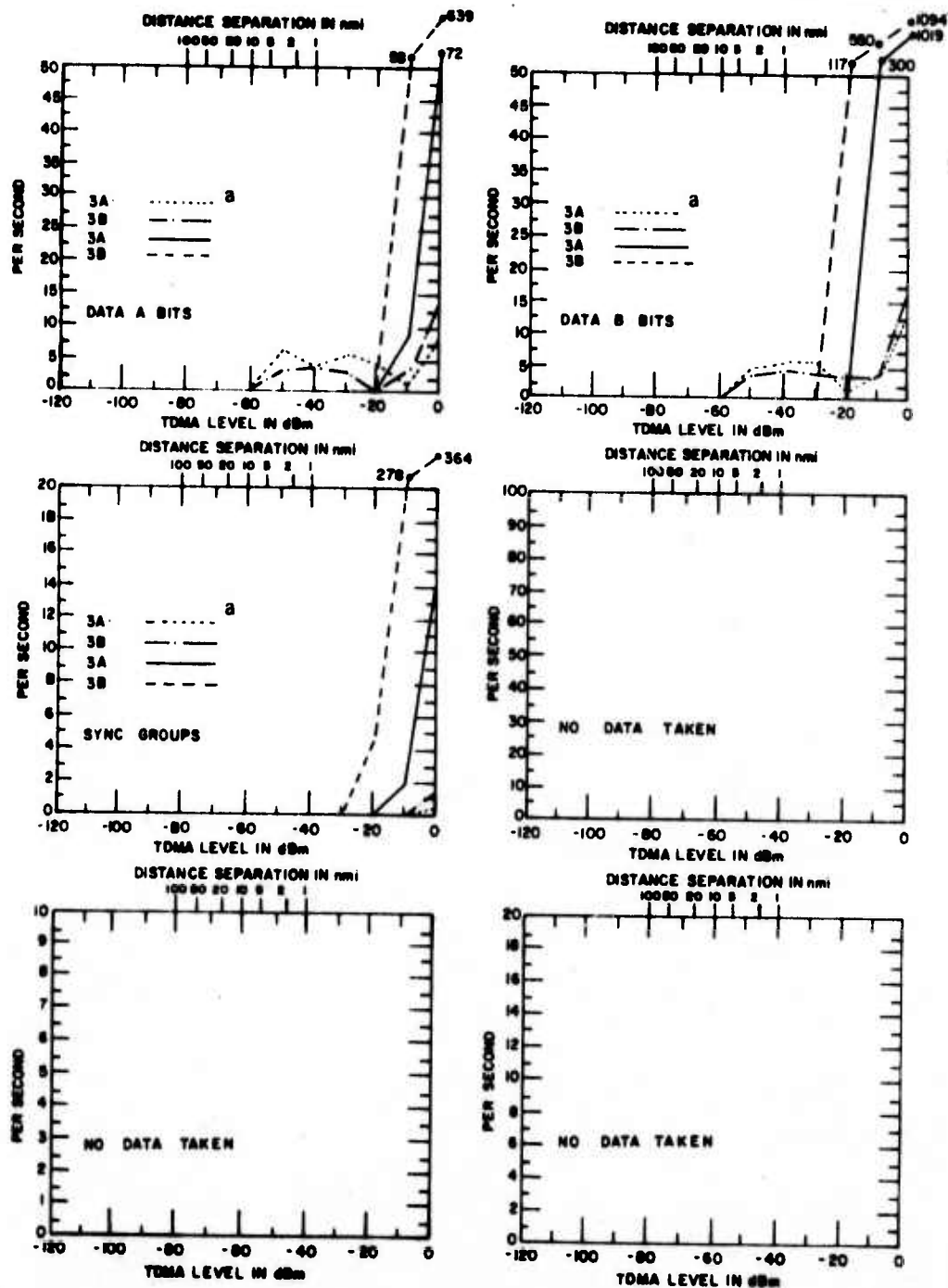

Figure E-15. Digital data broadcast test results for desired signal level of MDS + 10 dB and narrowband TDMA duty factor of 50%.



<sup>a</sup> First two are wideband, second two are narrowband.

Figure E-16. Digital data broadcast spurious decode test results for desired signal level of MDS + 2 dB and wide and narrowband TDMA duty factor of 50%.



<sup>a</sup>First two are wideband, second two are narrowband.

Figure E-17. Digital data broadcast spurious decode test results for desired signal level of MDS + 10 dB and wideband narrow-band TDMA duty factor of 50%.

APPENDIX F

IFF TRANSPONDER TEST RESULTS

CONTENTS

<u>Figure</u>	<u>Page</u>
F-1 Regency 505I test results (desired signal - MDS, wideband TDMA duty cycle - 50%) . . . . .	179
F-2 Regency 505I test results (desired signal - MDS, wideband TDMA duty cycle - 25%) . . . . .	180
F-3 Regency 505I test results (desired signal - MDS, narrowband TDMA duty cycle - 50%) . . . . .	181
F-4 Regency 505I test results (desired signal - MDS + 3 dB, wideband TDMA duty cycle - 50%) . . . . .	182
F-5 AN/APX-72 test results (desired signal level - MDS, TDMA duty cycle - 50%) . . . . .	183
F-6 AN/APX-72 test results as a function of desired signal level and as a function of TDMA duty cycle . .	184
F-7 COLLINS 621A-6 test results (desired signal - MDS, TDMA duty cycle - 50%) . . . . .	185
F-8 GENAVE 4096 test results (desired signal - MDS, TDMA duty cycle - 50%) . . . . .	186

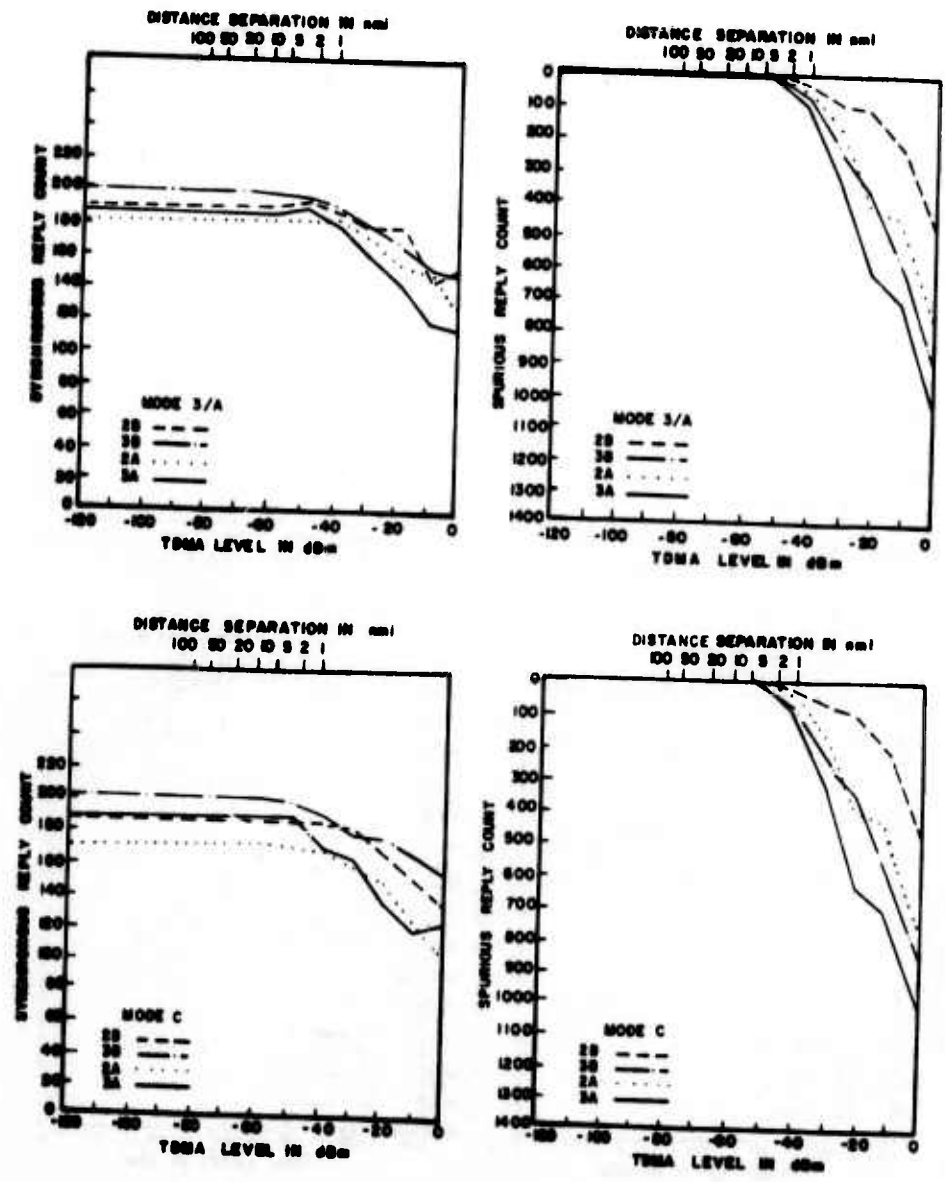

Figure F-1. Regency 505I test results (desired signal - MDS, wideband TDMA duty cycle - 50%).

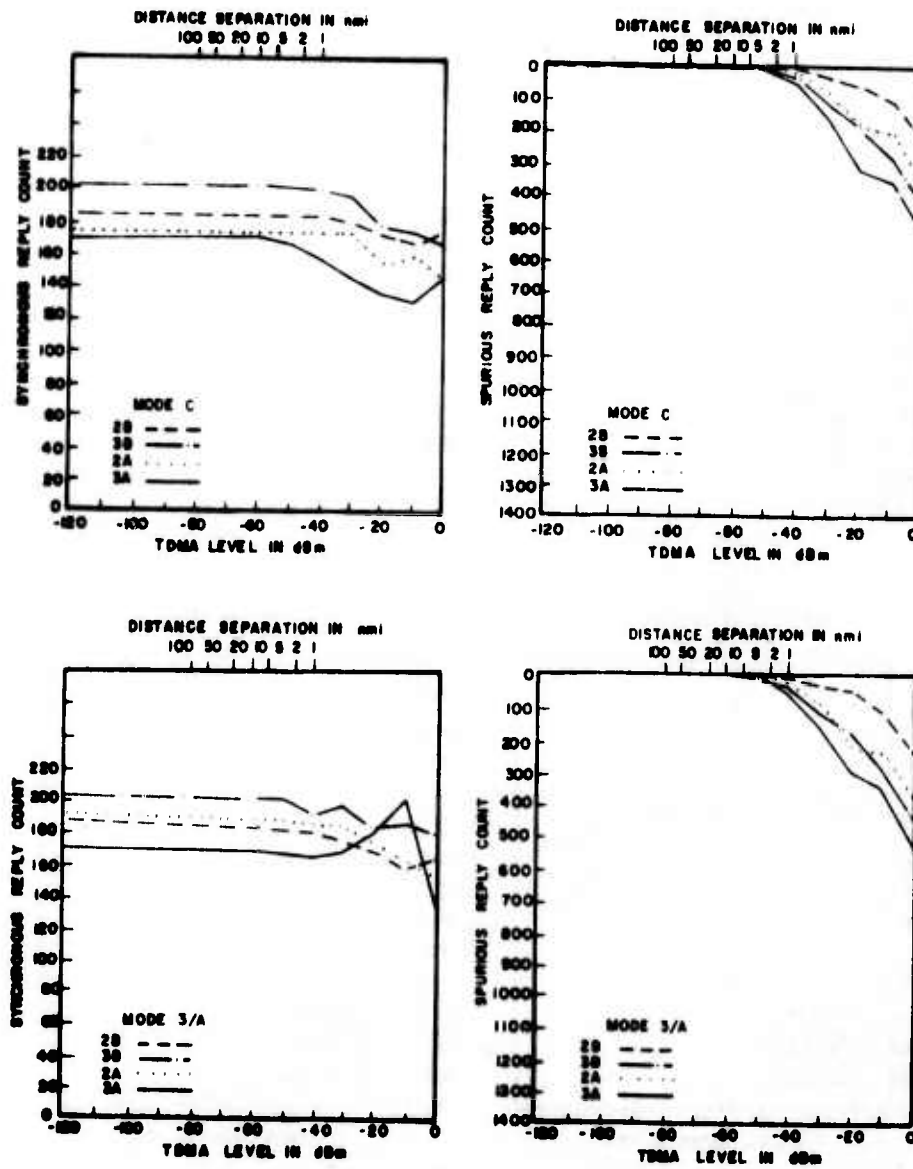

Figure F-2. Regency 505I test results (desired signal - MDS, wideband TDMA duty cycle - 25%).

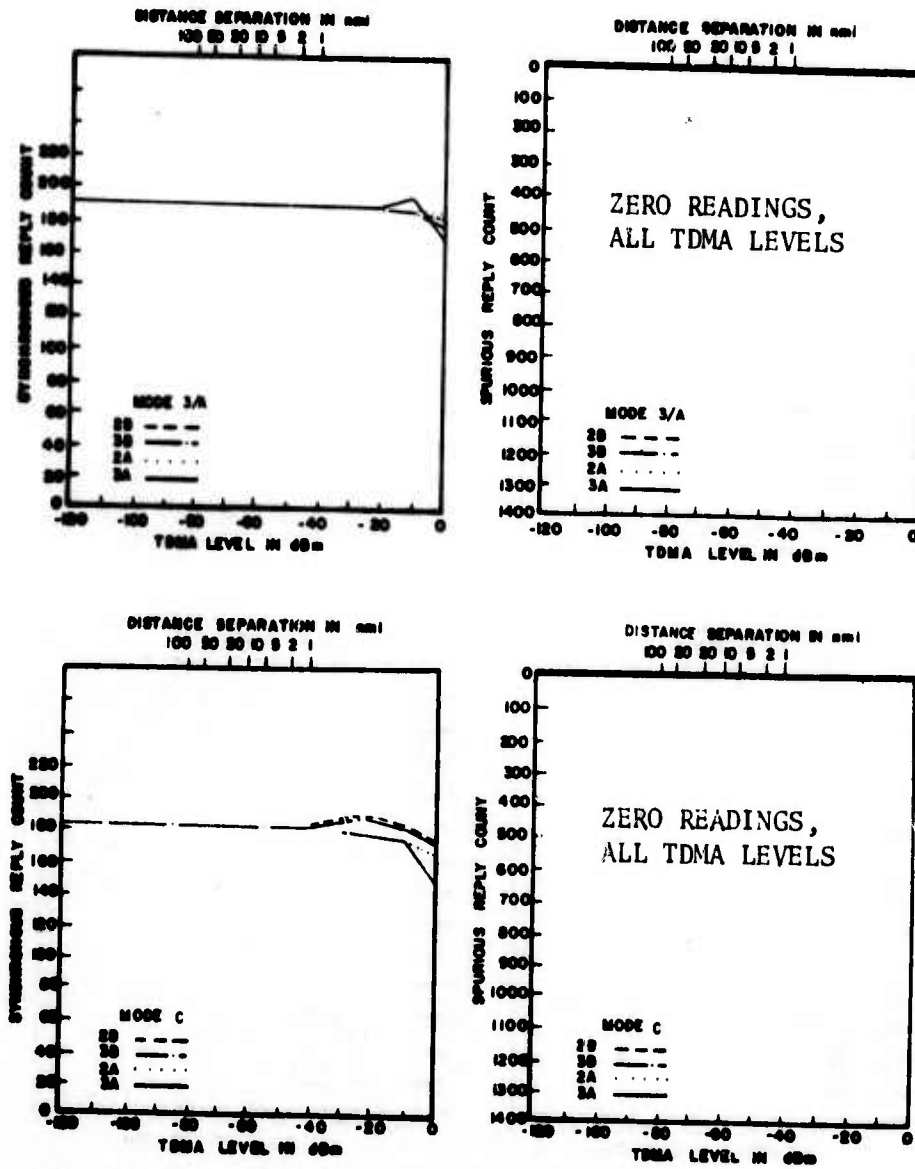

Figure F-3. Regency 505I test results (desired signal - MDS, narrow-band TDMA duty cycle - 50%).

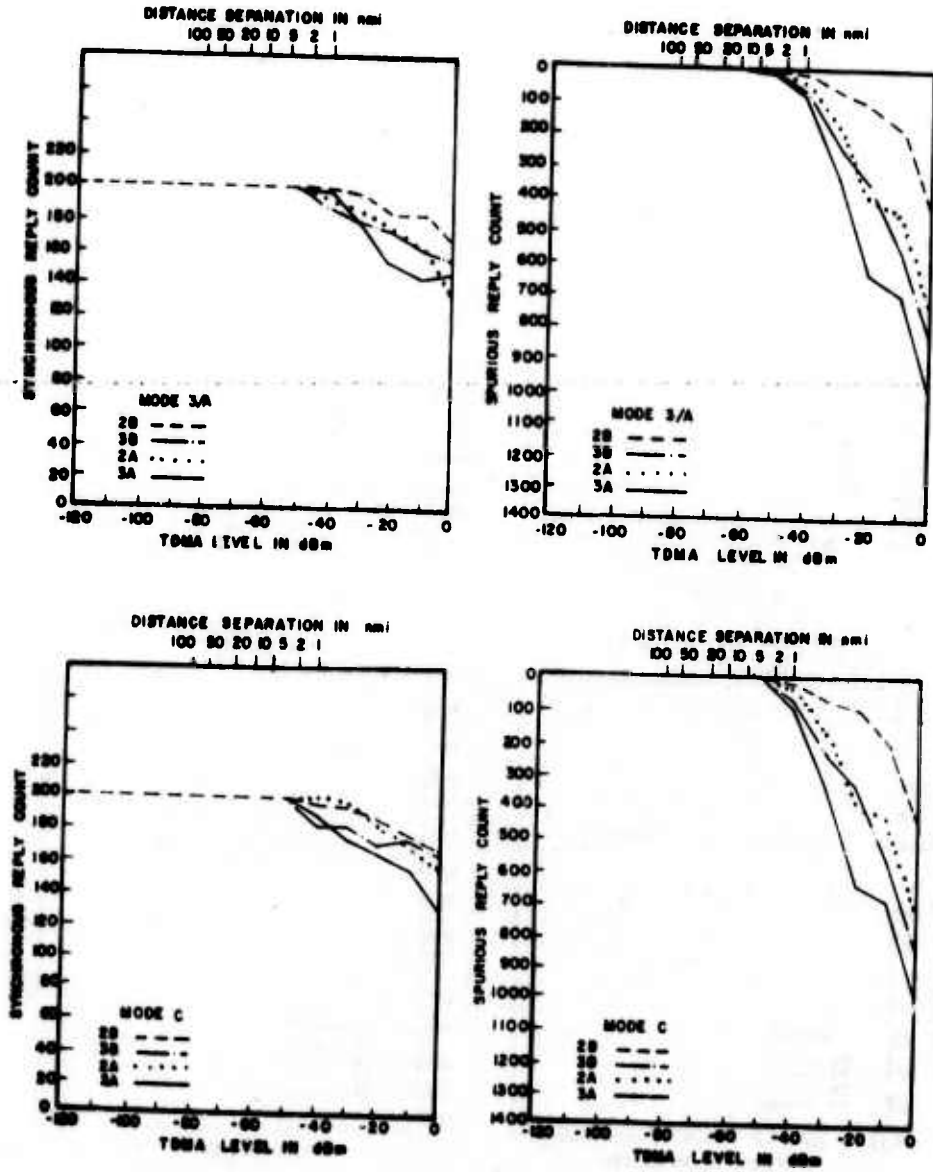

Figure F-4. Regency 505I test results (desired signal - MDS + 3 dB, wideband TDMA duty cycle - 50%).

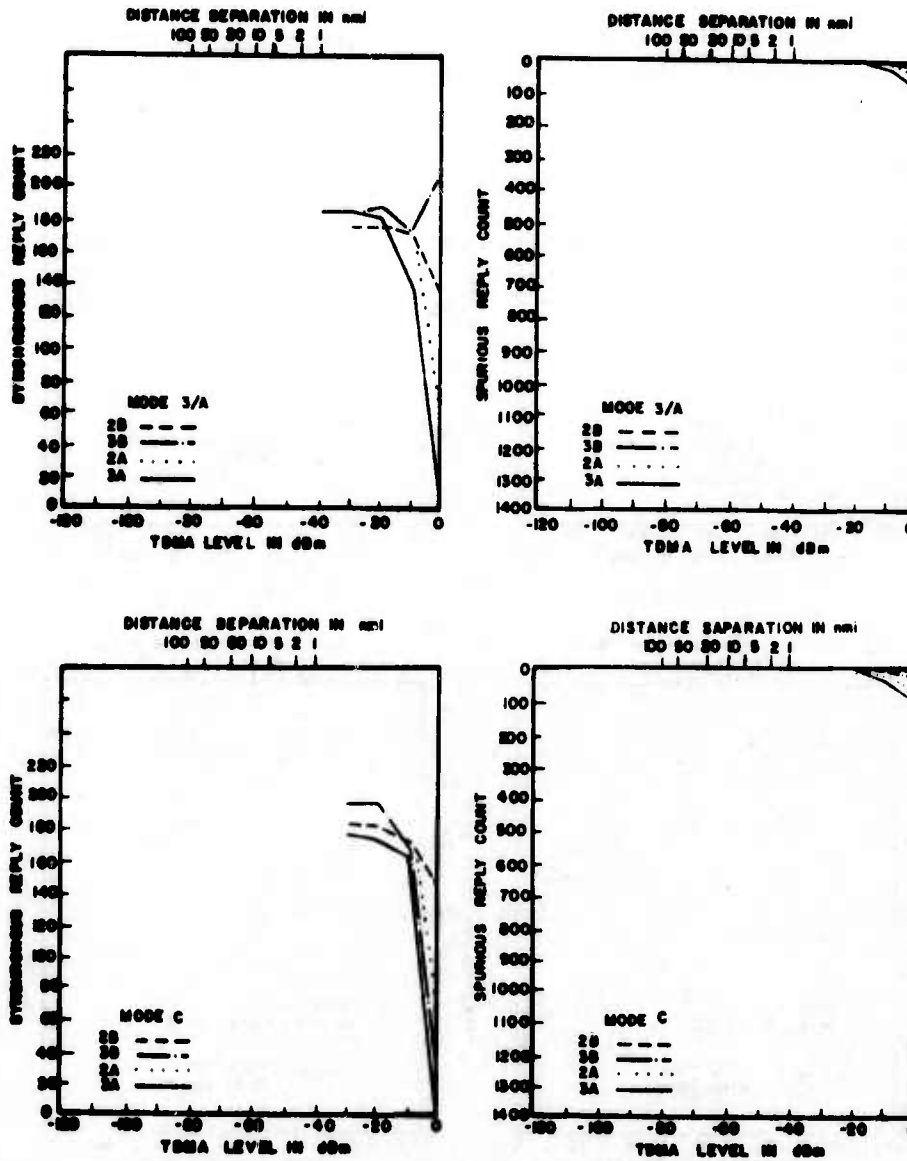

Figure F-5. AN/APX-72 test results (desired signal level - MDS, TDMA duty cycle - 50%).

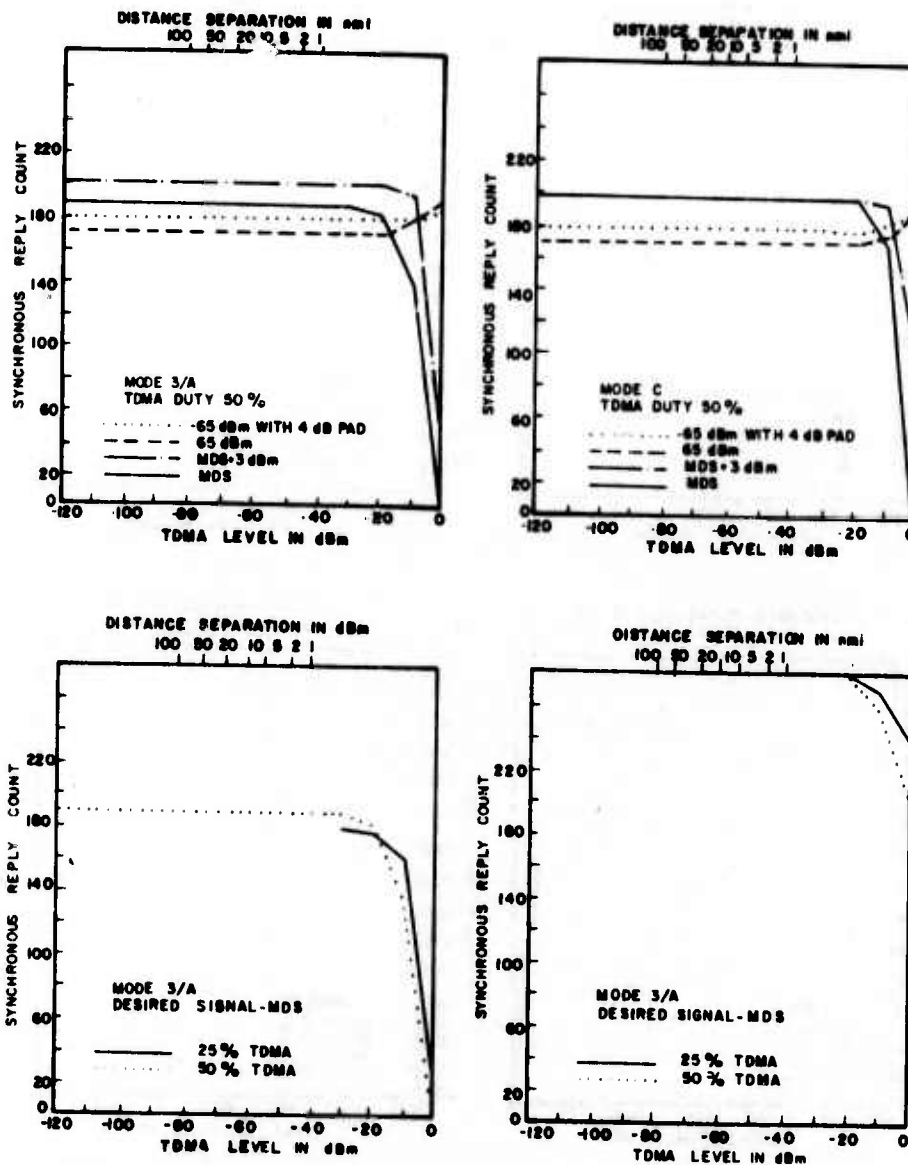

Figure F-6. AN/APX-72 test results as a function of desired signal level and as a function of TDMA duty cycle.

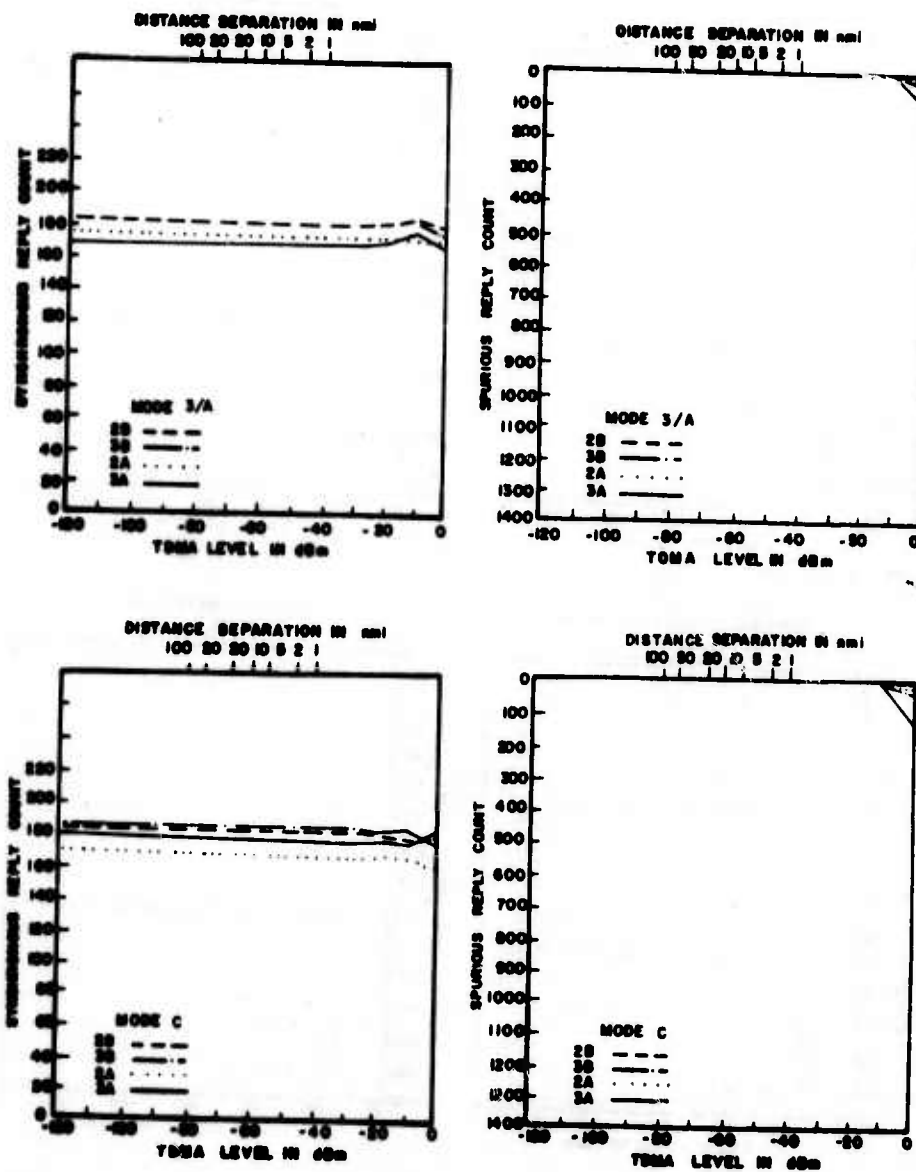

Figure F-7. COLLINS 621A-6 test results (desired signal - MDS, TDMA duty cycle - 50%).

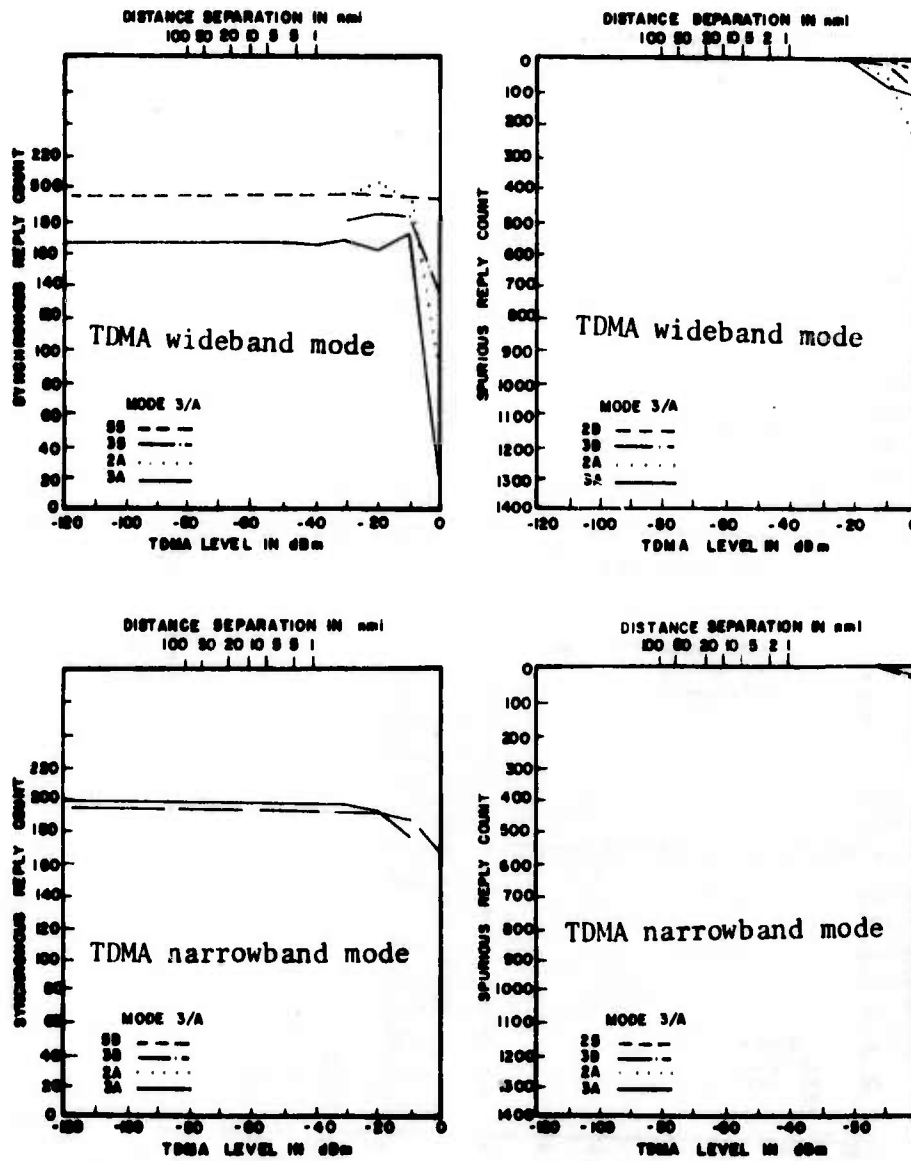

Figure F-8. GENAVE 4096 test results (desired signal - MDS, TDMA duty cycle - 50%).

APPENDIX G

IFF INTERROGATOR TEST RESULTS

CONTENTS

<u>Figure</u>	<u>Page</u>
G-1 ARTCBI-4 synchronous reply count data for desired signal level of MDS + 1 dB and a TDMA duty factor of 50% . . . . .	189
G-2 ARTCBI-4 synchronous reply count data for desired signal level of MDS + 1 dB and a TDMA duty factor of 25% . . . . .	190
G-3 ARTCBI-4 synchronous reply count data for desired signal level of MDS + 3 dB and a TDMA duty factor of 50% . . . . .	191
G-4 ARTCBI-4 synchronous reply count data for desired signal level of MDS + 3 dB and a TDMA duty factor of 25% . . . . .	192
G-5 ARTCBI-4 synchronous reply count data as a function of desired signal level (TDMA code - 3A-1, duty cycle - 50%) . . . . .	193
G-6 ARTCBI-4 synchronous reply count data as a function of reply code . . . . .	194
G-7 ARTCBI-4 spurious reply count data for TDMA duty cycle of 50% . . . . .	195
G-8 ARTCBI-4 spurious reply count data for TDMA duty cycle of 25% . . . . .	196

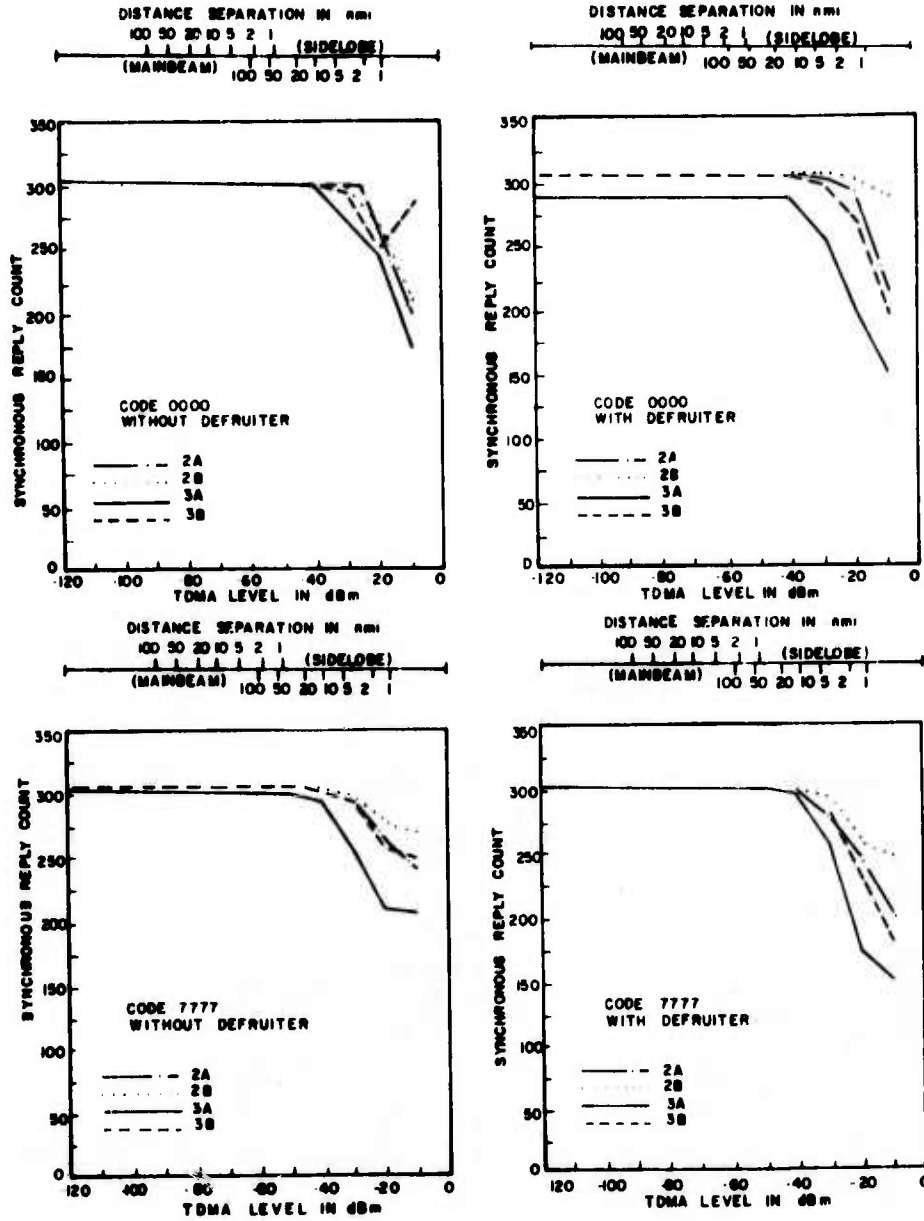

Figure G-1. ARTCBI-4 synchronous reply count data for desired signal level of MDS + 1 dB and a wideband TDMA duty factor of 50%.

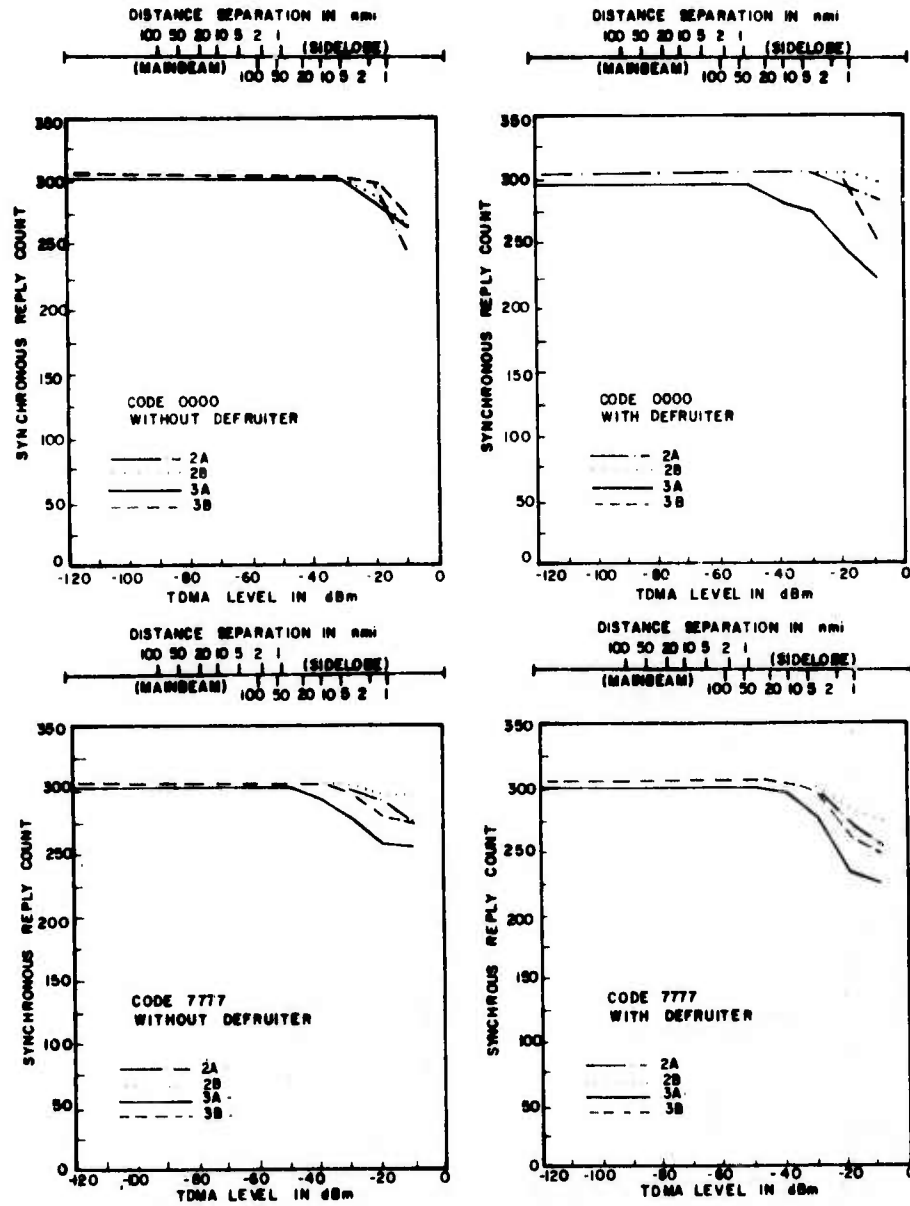

Figure G-2. ARTC81-4 synchronous reply count data for desired signal level of MDS + 1 dB and a wideband TDMA duty factor of 25%.

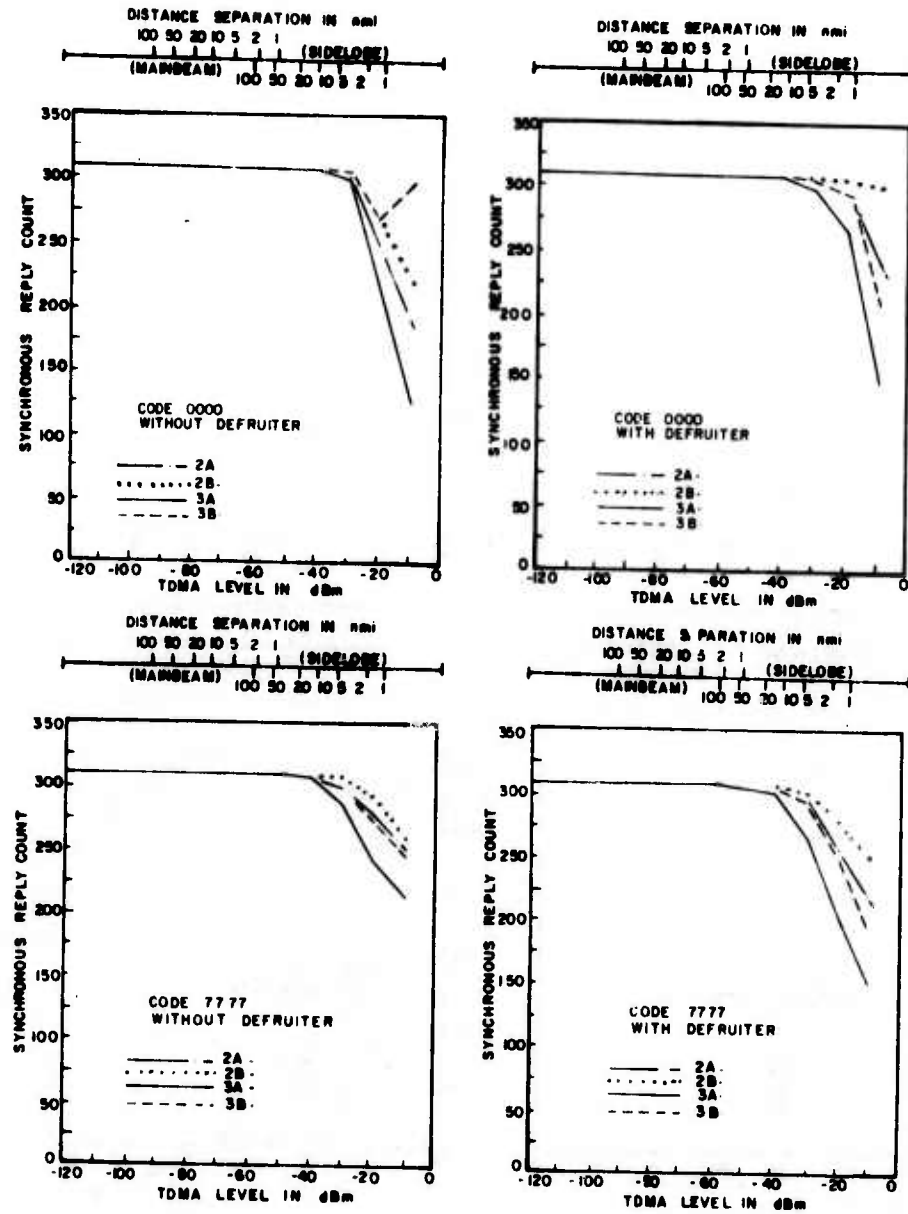

Figure G-3. ARTCBI-4 synchronous reply count data for desired signal level of MDS + 3 dB and a wideband TDMA duty factor of 50%.

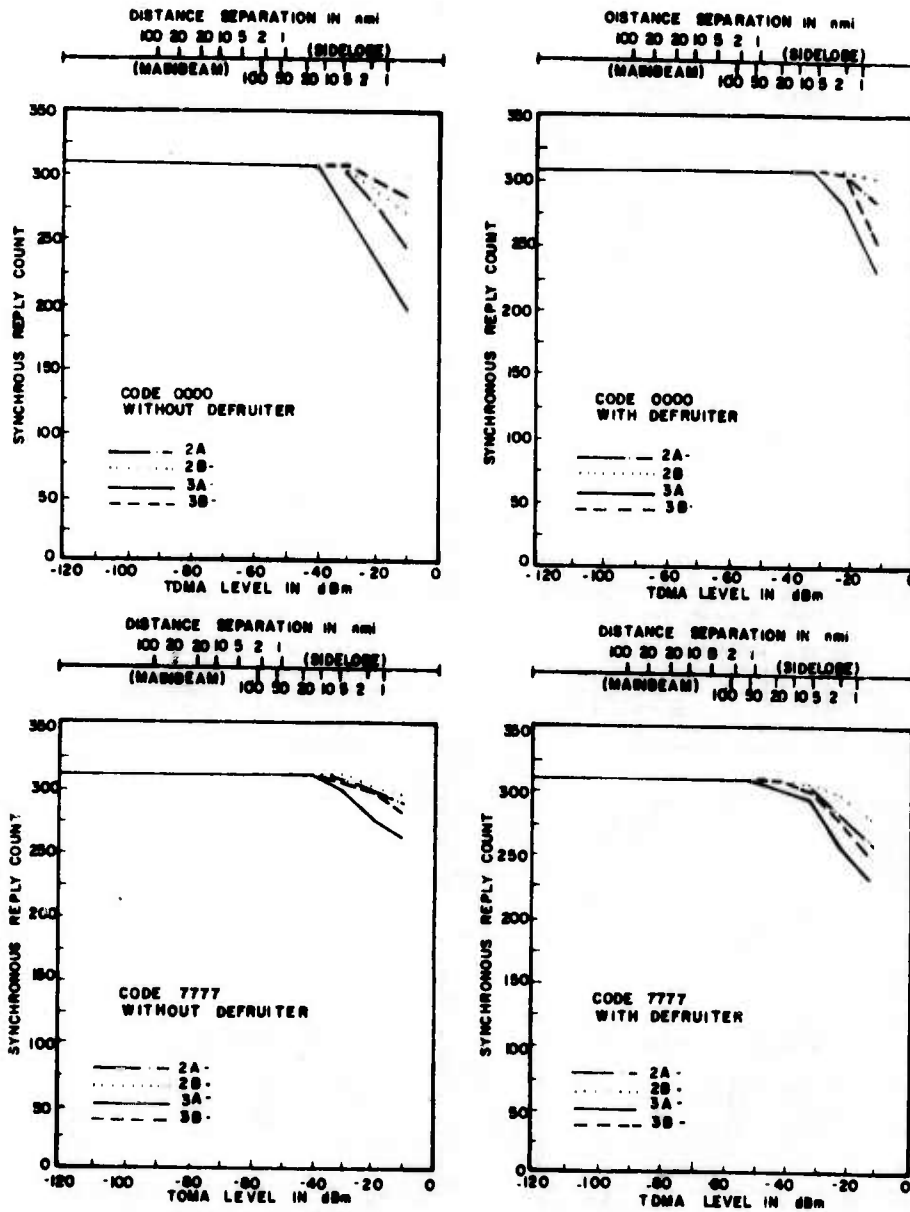

Figure G-4. ARTCBI-4 synchronous reply count data for desired signal level of MDS + 3 dB and a wideband TDMA duty factor of 25%.

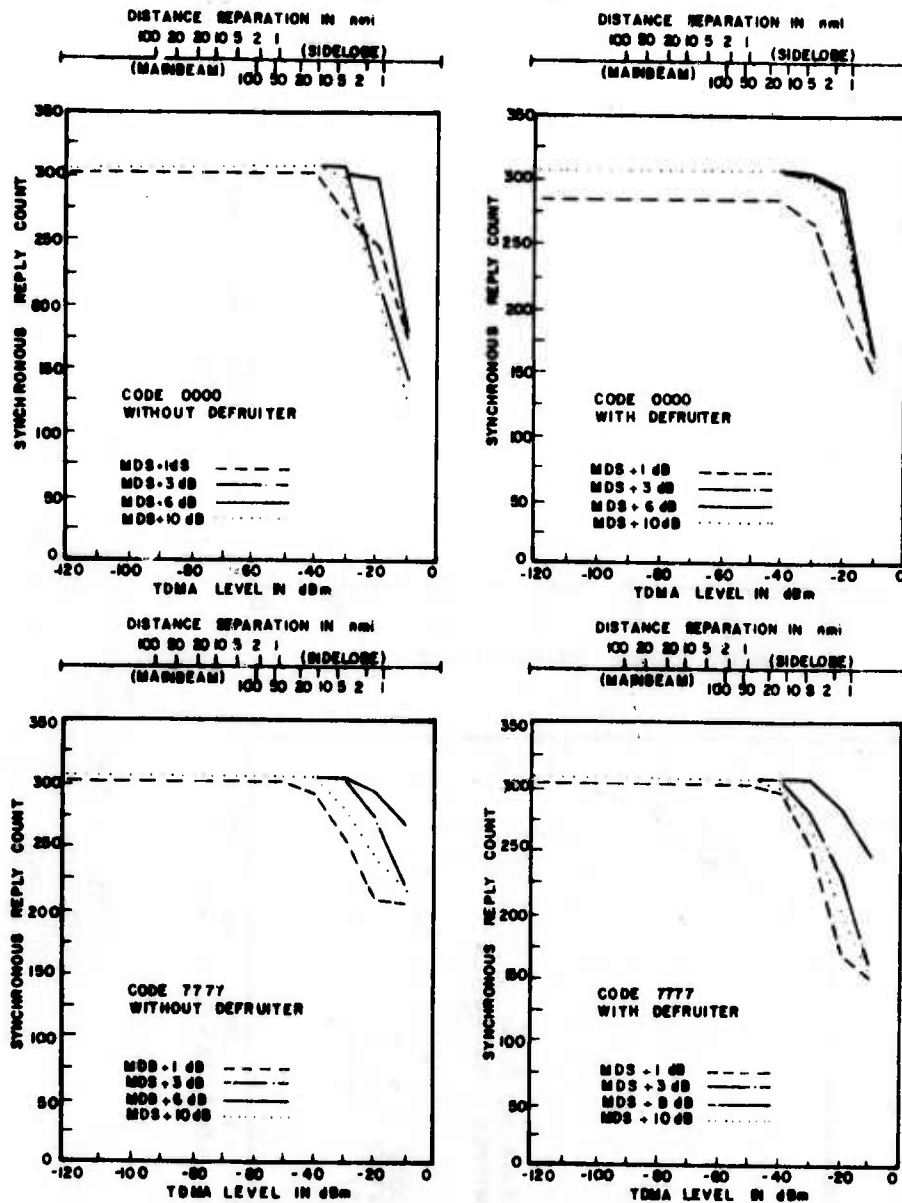
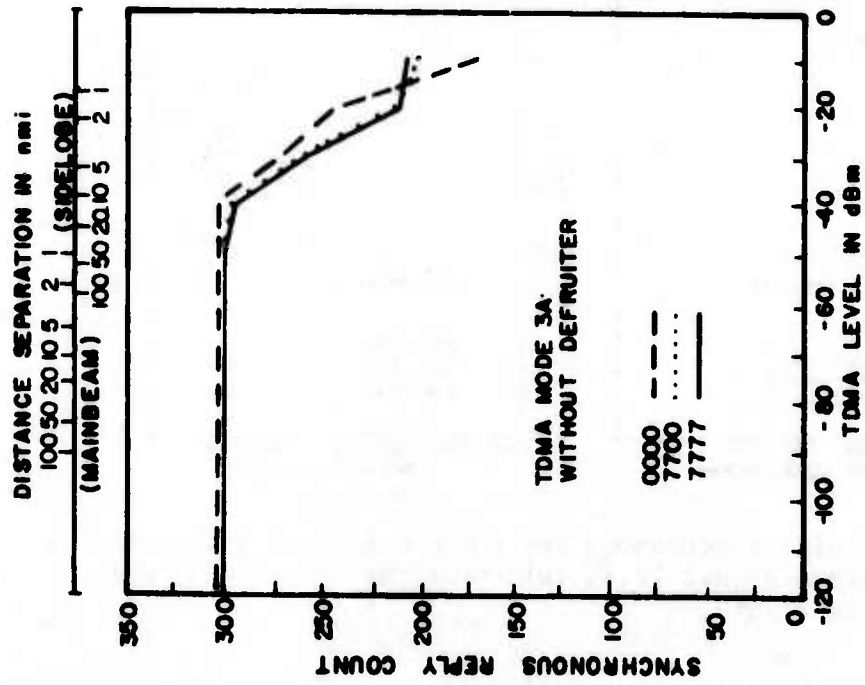
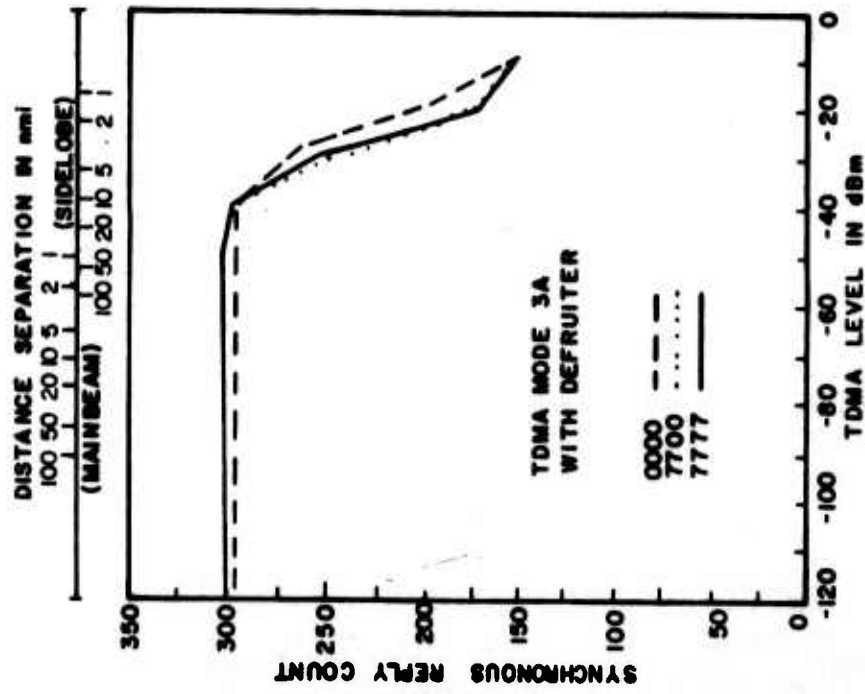

Figure G-5. ARTCBI-4 synchronous reply count data as a function of desired signal level (wideband TDMA code - 3A, duty cycle - 50%).



Desired signal level - MDS + 1 dB  
 TDMA duty cycle - 50%  
 TDMA mode - 3A wideband

Figure G-6. ARTCBI-4 synchronous reply count data as a function of reply code.

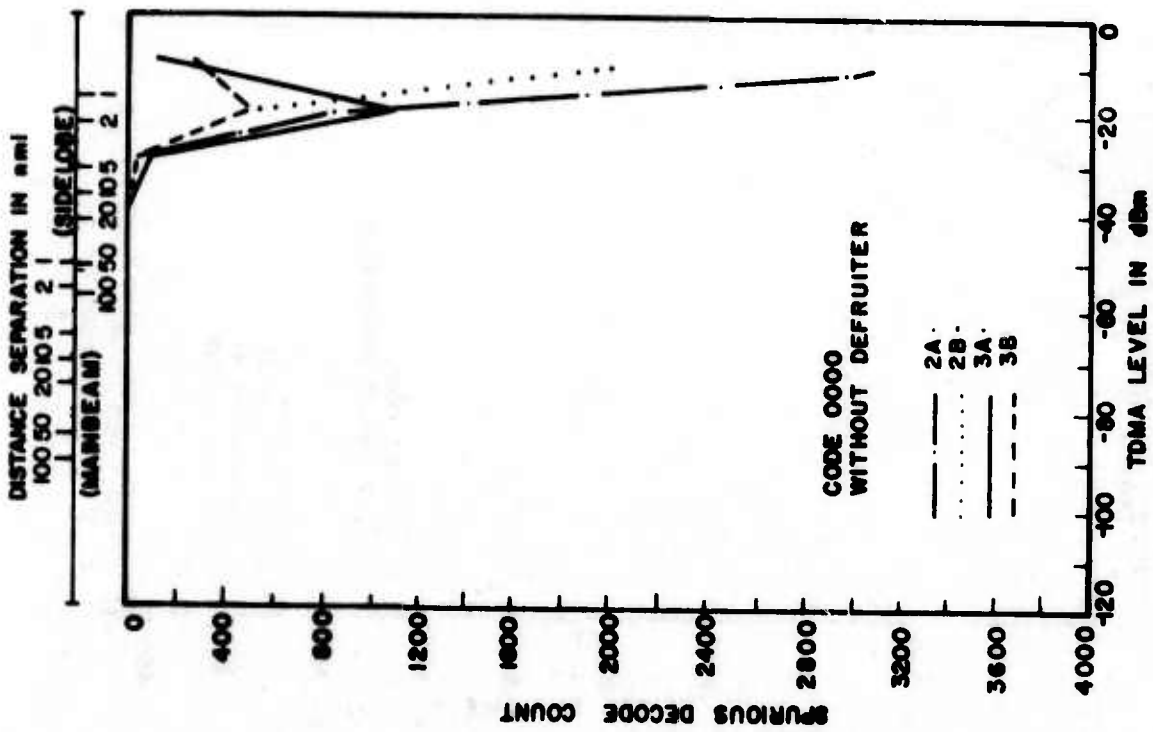
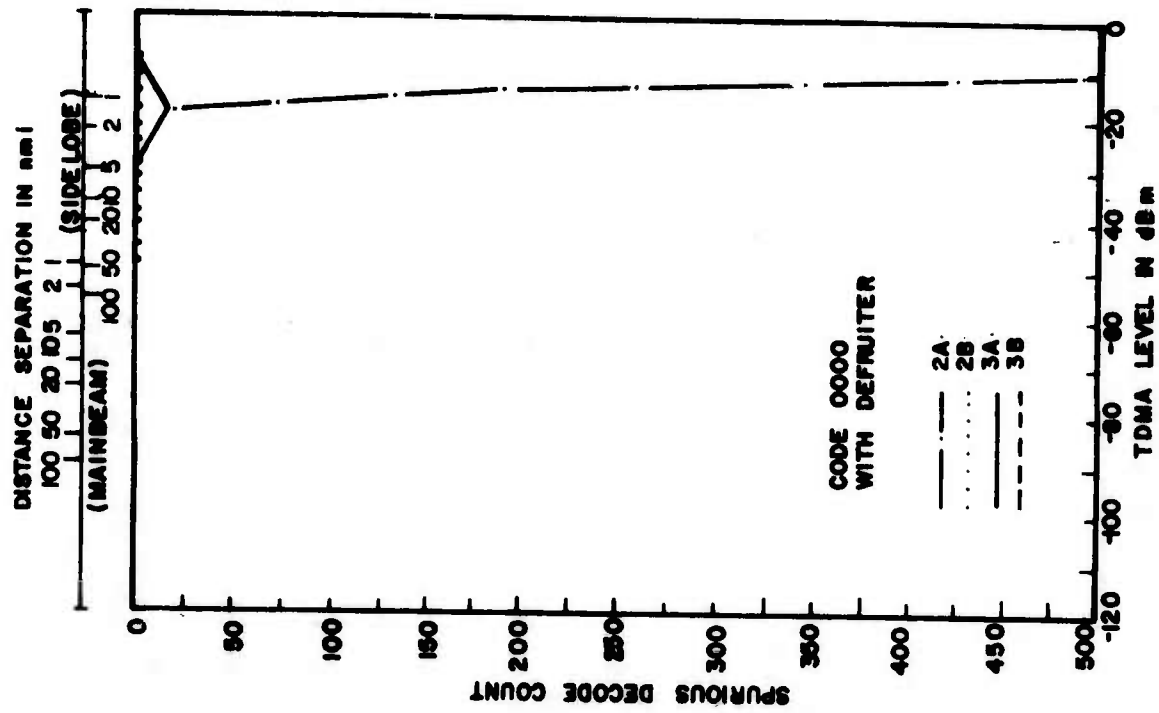

Figure G-7. ARTCBI-4 spurious reply count data for wideband TDMA duty cycle of 50%

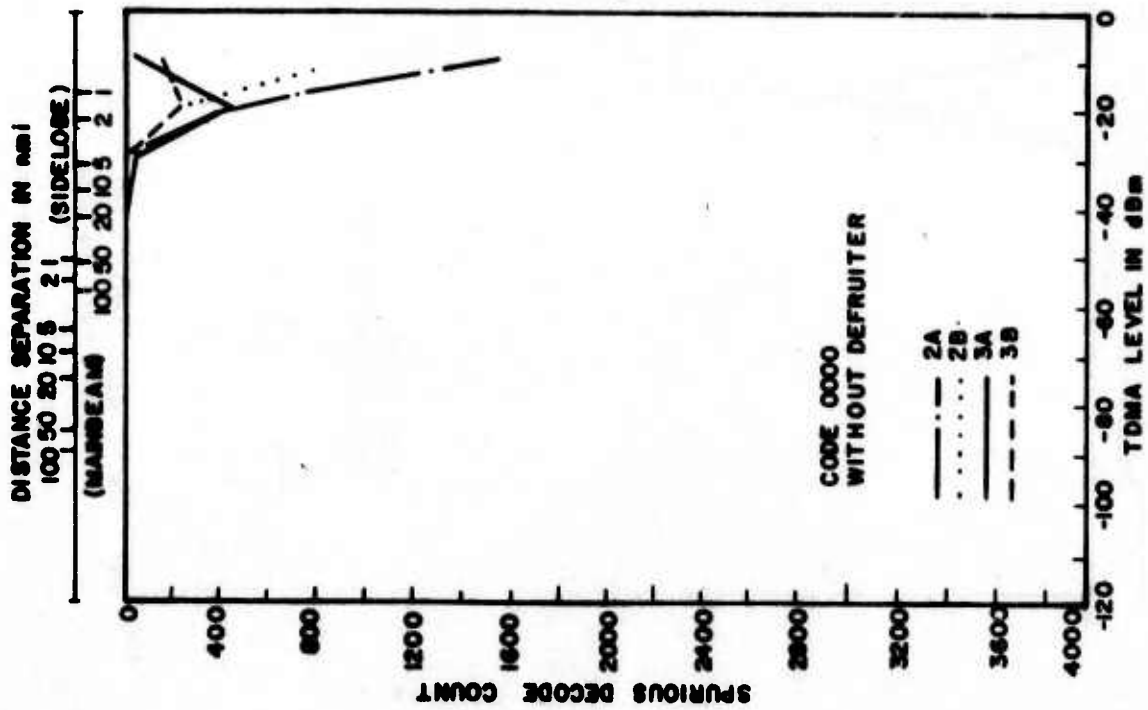
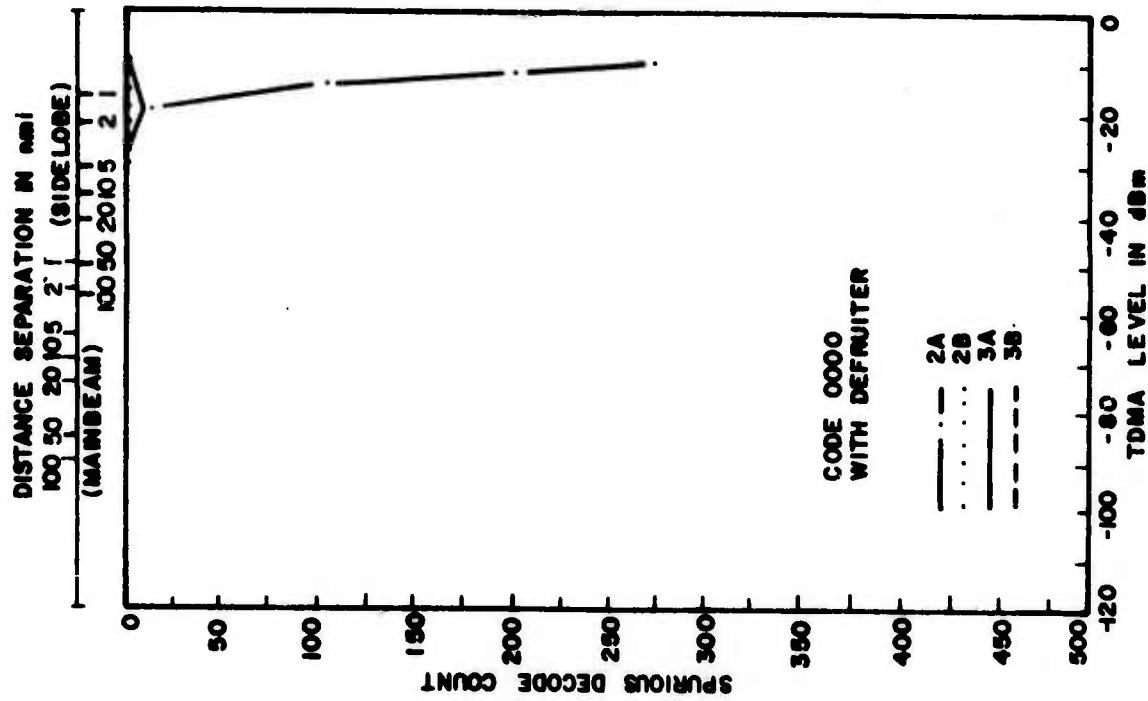

Figure G-8. ARTCBI-4 spurious reply count data for wideband TDMA duty cycle of 25%.