

UNCLASSIFIED

AD NUMBER

ADB010373

LIMITATION CHANGES

TO:

Approved for public release; distribution is unlimited.

FROM:

Distribution authorized to U.S. Gov't. agencies only; Test and Evaluation; 29 MAR 1976. Other requests shall be referred to Pacific Missile Test Center, ATTN: Code 4250, Point Mugu, CA 93042.

AUTHORITY

PMTC ltr dtd 10 Apr 1986

THIS PAGE IS UNCLASSIFIED

AD B0 10 373

AUTHORITY:

P M T C

1 yr 10 APR 86



L

JH (2)

Technical Publication TP-76-6 ✓



**TELEMETRY SYSTEM PARAMETERS
AND BIT ERROR PERFORMANCE
OF NRZ AND DM PCM/FM**

**(AIRTASK A5355352 054D 5W47410030,
Work Unit A535210000002)**

By

D. A. KING
Instrumentation Development Division

29 March 1976

ADB010373

**AD NO. _____
DDC FILE COPY**

TP-76-6 (U)

**DDC
RECEIVED
APR 21 1976
B**

DISTRIBUTION LIMITED TO U.S. GOVERNMENT AGENCIES ONLY;
TEST AND EVALUATION INFORMATION; 29 MARCH 1976. OTHER
REQUESTS FOR THIS DOCUMENT MUST BE REFERRED TO THE
COMMANDER (CODE 4250), PACIFIC MISSILE TEST CENTER,
POINT MUGU, CALIFORNIA 93042.

PACIFIC MISSILE TEST CENTER

Point Mugu, California

ACCESSION for	
NTIS	White Section <input type="checkbox"/>
DDC	Buff Section <input checked="" type="checkbox"/>
UNANNOUNCED <input type="checkbox"/>	
JUSTIFICATION	
BY	
DISTRIBUTION/AVAILABILITY CODES	
Dist.	AVAIL. and/or SPECIAL
B	

PACIFIC MISSILE TEST CENTER
 AN ACTIVITY OF THE NAVAL AIR SYSTEMS COMMAND

IRA N. SCHWARZ, CAPT USN
Commander

W. L. MILLER
Technical Director

This report describes work performed under AIRTASK A5355352 054D 5W47410030, Missile Flight Evaluation Systems, Work Unit A535210000002.

Mr. F. R. Hartzler, Head, Component Development Branch, and Mr. K. L. Berns, Head, Instrumentation Development Division, have reviewed this report for publication.

Released by:
 M. H. Cain
 Telemetry Project Manager

Technical Publication TP-76-6

Published by Technical Publications Division
 Photography and Technical Information Department
 Security classification UNCLASSIFIED
 First printing 205 copies



DEPARTMENT OF THE NAVY
COMMANDER
PACIFIC MISSILE TEST CENTER
POINT MUGU, CALIFORNIA 93042

IN REPLY REFER TO:

4250/me
Ser: 7009
29 March 1976

From: Commander, Pacific Missile Test Center
To: Distribution List

Subj: PMTC Technical Publication TP-76-6 "Telemetry System Parameters and Bit Error Performance of NRZ and DM PCM/FM" by D. A. King, dtd 29 March 1976; supplement to

1. The following should be added to page 3: bit synchronizer A was the EMR 720 and bit synchronizer B was the Monitor 335.
2. This information was not included in the text of the report to avoid the possibility of construing the results as a comparison of the two bit synchronizers.

A handwritten signature in cursive script, appearing to read "W. J. Kirkpatrick".

W. J. KIRKPATRICK
By direction



UNCLASSIFIED

SECURITY CLASSIFICATION OF THIS PAGE (When Data Entered)

REPORT DOCUMENTATION PAGE		READ INSTRUCTIONS BEFORE COMPLETING FORM
1. REPORT NUMBER TP-76-6	2. GOVT ACCESSION NO. (9) Technical publications	3. RECIPIENT'S CATALOG NUMBER
(6) 4. TITLE (and Subtitle) TELEMETRY SYSTEM PARAMETERS AND BIT ERROR PERFORMANCE OF NRZ AND DM PCM/FM		5. TYPE OF REPORT & PERIOD COVERED
		6. PERFORMING ORG. REPORT NUMBER
7. AUTHOR(s) (10) D. A. King	(14) PMTC-TP-76-6	8. CONTRACT OR GRANT NUMBER(s)
9. PERFORMING ORGANIZATION NAME AND ADDRESS Pacific Missile Test Center Point Mugu, California 93042		10. PROGRAM ELEMENT PROJECT, TASK AREA & WORK UNIT NUMBERS AIRTASK A5355352/054D/ 5W47410030, Work Unit A53521000002
11. CONTROLLING OFFICE NAME AND ADDRESS Naval Air Systems Command Washington, DC 20361	(11)	12. REPORT DATE 29 March 1976
		13. NUMBER OF PAGES 25
14. MONITORING AGENCY NAME & ADDRESS (if different from Controlling Office)		15. SECURITY CLASS. (of this report) UNCLASSIFIED
(12) 32 p.		15a. DECLASSIFICATION/DOWNGRADING SCHEDULE
16. DISTRIBUTION STATEMENT (of this report) Distribution limited to U.S. Government agencies only; test and evaluation information; 29 March 1976. Other requests for this document must be referred to the Commander (Code 4250), Pacific Missile Test Center, Point Mugu, California 93042.		
17. DISTRIBUTION STATEMENT (of the abstract entered in Block 20, if different from Report)		
(16) A535-5352/054-D/5W47-410-030		
18.		
19. KEY WORDS (Continue on reverse side if necessary and identify by block number) Non-return-to-zero RF bandwidth Delay modulation (Miller code) PCM/FM optimization Bit error probability		
20. ABSTRACT (Continue on reverse side if necessary and identify by block number) The work reported herein involved the experimental determination of optimum telemetry system parameters for the transmission of NRZ and DM PCM/FM. The objective was to compare the efficiency of the two PCM formats and to evaluate rules of thumb for determining system parameters. A PCM/FM telemetry system was simulated and optimum receiver IF bandwidth, RF transmitter deviation, and premodulation filter bandwidth for the transmission of NRZ and DM were determined so that NRZ and DM performance could be compared on an equivalent basis. (Continued)		

DOVER

UNCLASSIFIED

SECURITY CLASSIFICATION OF THIS PAGE (When Data Entered)

409 248 ✓

mt

UNCLASSIFIED

SECURITY CLASSIFICATION OF THIS PAGE(When Data Entered)

20. ABSTRACT (Concluded)

NRZ and DM rules of thumb were examined to determine the system performance loss due to non-optimum operation.

The experiment verified other reported conclusions that show NRZ to be 3 dB better than DM for equivalent bit rates under their respective optimum conditions. Thus DM is not recommended for applications of maximum data transfer in a bandlimited RF system where noisy signals may be received. Use of rules of thumb in setting system parameters will generally result in less than 3 dB degradation in BEP as long as the rules fall within certain bounds about optimum:

1. The receiver IF bandwidth should be at least twice the optimum (f_B for NRZ, $2f_B$ for DM) for data-recording purposes. The equivalent bandwidth of the pre-recording and post-recording IF combination should be close to f_B but less than $2f_B$ for NRZ and close to $2f_B$ but less than $4f_B$ for DM.
2. The peak-to-peak RF transmitter deviation should lie between $0.6f_B$ and $0.9f_B$ for NRZ and between $1.2f_B$ and $1.8f_B$ for DM.
3. The premodulation filter bandwidth should fall between $0.5f_B$ and $1.0f_B$ for both NRZ and DM.

UNCLASSIFIED

SECURITY CLASSIFICATION OF THIS PAGE(When Data Entered)

ACKNOWLEDGMENT

The author wishes to thank F. R. Hartzler and E. L. Law for their assistance throughout this project.

CONTENTS

	Page
ABBREVIATIONS	v
SUMMARY.	1
INTRODUCTION	3
TEST EQUIPMENT	3
TEST METHODS AND RESULTS	4
RF Transmitter Deviation	4
IF Bandwidth	9
Premodulation Filter Bandwidth.	11
RF Bandwidth.	14
NRZ AND DM	20
SUMMARY OF RESULTS	20
REFERENCES	25
TABLES	
1. Equipment List	4
2. NRZ Optimum Deviations for Various IF Filter Bandwidths	9
FIGURES	
1. System Block Diagram	4
2. BEP Variations With RF Deviation for NRZ PCM/FM	6
3. BEP Variations With RF Deviation for DM PCM/FM.	7
4. NRZ RF Signal Spectra	8
5. DM RF Signal Spectra	10
6. NRZ Bit Error Sensitivity to IF Filter Bandwidth.	12
7. DM Bit Error Sensitivity to IF Filter Bandwidth	13
8. NRZ BEP Variations With Premodulation Filter Bandwidth	15
9. DM BEP Variations With Premodulation Filter Bandwidth	16
10. NRZ BEP Sensitivity to RF Deviation and Premodulation Filter Bandwidth	17
11. DM BEP Sensitivity to RF Deviation and Premodulation Filter Bandwidth	18
12. Bit Rates Containable in 1 MHz and 3 MHz RF Channel Bandwidths by Band Limiting With a Premodulation Filter	19
13. PCM Signaling Formats	21
14. NRZ PCM Video Spectra of a Pseudo-Random Pattern	22
15. DM PCM Video Spectra of a Pseudo-Random Pattern	23
16. Comparison of Optimum NRZ and DM PCM/FM Bit Error Probabilities	24

ABBREVIATIONS

AGC	Automatic gain control
BEP	Bit error probability
BW	Bandwidth
dB	Decibels
dBm	Decibels with reference to 1 milliwatt
DM	Delay modulation (or Miller code)
f_B	Bit rate
FM	Frequency modulation
F/S	Filter/sample bit detector
FSK	Frequency shift keying
GHz	Gigahertz
I/D	Integrate and dump bit detector
IF	Intermediate frequency
IRIG	Inter-Range Instrumentation Group
kb/s	Kilobits per second
kHz	Kilohertz
Mb/s	Megabits per second
MHz	Megahertz
NRZ	Non-return-to-zero
PCM	Pulse code modulation
P-P	Peak-to-peak
RF	Radio frequency
SNR	Signal-to-noise ratio

v

PRECEDING PAGE BLANK-NOT FILMED

TELEMETRY SYSTEM PARAMETERS AND BIT ERROR
PERFORMANCE OF NRZ AND DM PCM/FM

(AIRTASK A5355352 054D 5W47410030,
Work Unit A535210000002)

By
D. A. KING

SUMMARY

The work reported herein involved the experimental determination of optimum telemetry system parameters for the transmission of NRZ and DM PCM/FM. The objective was to compare the efficiency of the two PCM formats and to evaluate rules of thumb for determining system parameters. A PCM/FM telemetry system was simulated and optimum receiver IF bandwidth, RF transmitter deviation, and premodulation filter bandwidth for the transmission of NRZ and DM were determined so that NRZ and DM performance could be compared on an equivalent basis. NRZ and DM rules of thumb were examined to determine the system performance loss due to non-optimum operation.

The experiment verified other reported conclusions that show NRZ to be 3 dB better than DM for equivalent bit rates under their respective optimum conditions. Thus DM is not recommended for applications of maximum data transfer in a bandlimited RF system where noisy signals may be received.

The experimental optimum values of RF transmitter deviation, IF filter bandwidth, and premodulation filter bandwidth were found to be:

	NRZ		DM	
	F/S	I/D	F/S	I/D
P-P RF Transmitter Deviation	$0.8f_B$	$0.9f_B$	$1.6f_B$	$1.8f_B$
IF Filter Bandwidth	$1.0f_B$	$1.0f_B$	$2.0f_B$	$2.0f_B$
Premodulation Filter Bandwidth	$0.5f_B$ to $1.0f_B$	$0.5f_B$ to $1.0f_B$	$0.5f_B$ to $1.0f_B$	$0.5f_B$ to $1.0f_B$

Use of rules of thumb in setting system parameters will generally result in less than 3 dB degradation in BEP as long as the rules fall within certain bounds about optimum:

1. The receiver IF bandwidth should be at least twice the optimum for data-recording purposes. The equivalent bandwidth of the prerecording and post-recording IF combination should be close to f_B but less than $2f_B$ for NRZ and close to $2f_B$ but less than $4f_B$ for DM.
2. The peak-to-peak RF transmitter deviation should lie between $0.6f_B$ and $0.9f_B$ for NRZ and between $1.2f_B$ and $1.8f_B$ for DM.
3. The premodulation filter bandwidth should fall between $0.5f_B$ and $1.0f_B$ for both NRZ and DM.

(U) Publication UNCLASSIFIED.

Distribution limited to U.S. Government agencies only;
test and evaluation information; 29 March 1976. Other
requests for this document must be referred to the
Commander (Code 4250), Pacific Missile Test Center,
Point Mugu, California 93042.

INTRODUCTION

An experiment was conducted on a simulated RF telemetry link to compare the bit error performance characteristics of two PCM formats, delay modulation (DM or Miller code) and non-return-to-zero (NRZ). A valid comparison required that the telemetry system be operated in an optimum manner such that bit errors for both PCM signals were minimized for equivalent data transfer. Consequently, this report is also concerned with establishing optimum values for NRZ and DM system parameters. There were four parameters under control in the simulated telemetry link with which to minimize the bit errors: the PCM format, the premodulation filter bandwidth, the RF transmitter deviation, and the receiver IF bandwidth. All other system parameters were held constant during the experiment.

The criterion for optimality was that combination of parameter values for each of the two codes which minimized their bit error probability (BEP). However, optimum parameter values for minimizing BEP may not be optimum from the viewpoint of RF bandwidth considerations. To remain within an RF channel assignment, the trading of more bit errors for a narrower RF signal bandwidth may be necessary. This tradeoff can be accomplished by decreasing the RF transmitter deviation and premodulation filter bandwidth from their optimum values. Both RF bandwidth and minimization of BEP were considered in this experiment. The work was performed under AIRTASK A5355352 054D 5W47410030, Missile Flight Evaluation Systems, work unit A53521000002, to provide analytical support to the Telemetry Group of the Range Commanders Council.

TEST EQUIPMENT

The simulated telemetry system and associated test equipment are shown in figure 1. The equipment is listed in table 1.

The EMR 721 test set served as both a bit error rate detector and an NRZ and DM signal generator with variable bit rate. The NRZ and DM signals were pseudo-random sequences of 2,047 bits. The premodulation filter was a four-pole, linear phase filter with adjustable bandwidth. RF transmitter deviation and RF attenuation were adjustable on the FM signal generator which was operated at a carrier frequency of approximately 1.48 GHz. The receiver IF bandwidth was selectable from the following fixed units: 100 kHz, 200 kHz, 500 kHz, 750 kHz, and 1.0 MHz. The receiver's video filter was bypassed and the video signal applied directly to one of two bit synchronizers. Bit synchronizer A contained both a $0.75f_B$ matched filter/sample bit detector and an integrate and dump detector. Bit synchronizer B contained only an integrate and dump detector. The selected bit synchronizer returned the recovered NRZ and DM bit streams to the EMR 721 for error detection. RF bandwidth was monitored on a spectrum analyzer.

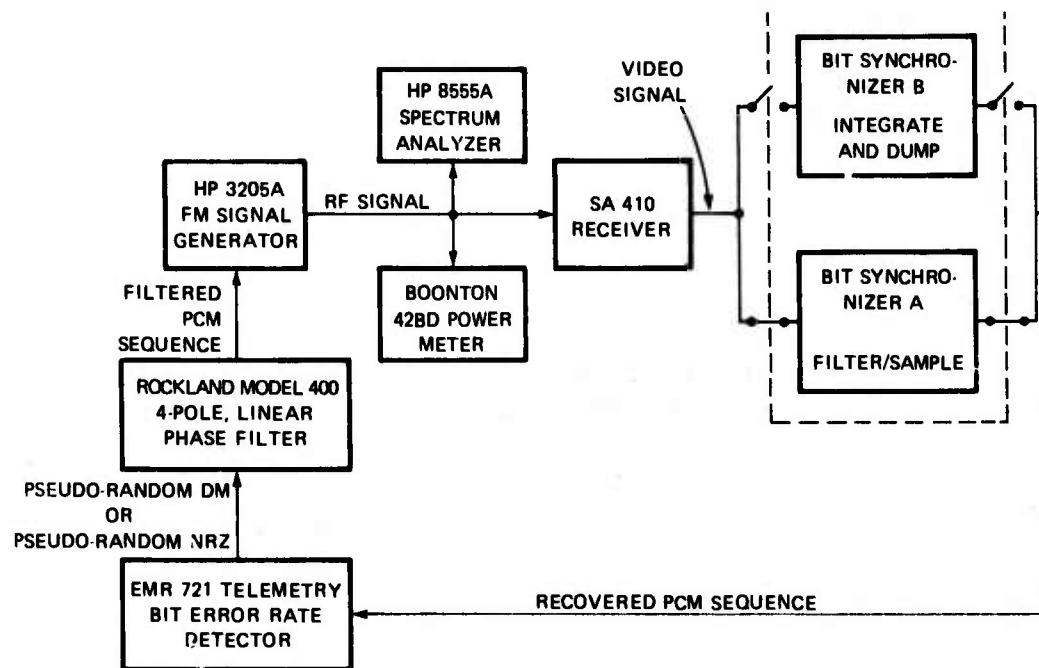

Figure 1. System Block Diagram.

Table 1. Equipment List

Bit error rate detector, EMR 721
Bit synchronizers A and B, two state-of-the-art bit synchronizers
Premodulation filter, Rockland model 1200
FM signal generator, HP 3205A
Receiver, Scientific-Atlanta series 410 WA
Oscilloscope, Tektronix type 564
Spectrum Analyzer, HP 8555A
Microwattmeter, Boonton Electronics 42 BD

TEST METHODS AND RESULTS

The system parameters for NRZ and DM were first optimized for minimum BEP and then RF bandwidth considerations were examined. The initial parameter values were set according to the following commonly used rules of thumb:

	NRZ	DM
P-P RF Transmitter Deviation	$0.7f_B$	$1.2f_B$
Premodulation Filter Bandwidth	$0.6f_B$	$0.6f_B$
Receiver IF Bandwidth	f_B	$2.0f_B$

where f_B is the bit rate.

RF Transmitter Deviation

The optimum RF transmitter deviations for NRZ and DM were found by fixing the attenuation of the RF signal such that the BEP was approximately 10^{-4} . The deviation and BEP were recorded as the

deviation was incrementally varied at the transmitter so that BEP variations were adequately defined. Increasing the RF attenuation in 2 dB steps and repeating the deviation and BEP measurements resulted in a family of curves from which the optimum deviation could be determined. Figure 2 for NRZ and figure 3 for DM show the BEP variations with RF transmitter deviation for f_B equal to a 500 kb/s rate. This data shows that the optimum deviations are ± 200 kHz at the 500 kb/s rate for NRZ and ± 400 kHz for DM. NRZ bit rates of 200 kb/s and 750 kb/s were also investigated and their optimum deviations were found to be ± 80 kHz and ± 300 kHz, respectively. DM bit rates of 100 kb/s and 375 kb/s were investigated and their optimum deviations were also found to be ± 80 kHz and ± 300 kHz, respectively. In general, the data indicate that the optimum peak-to-peak RF transmitter deviations are $0.8f_B$ for NRZ and $1.6f_B$ for DM with the other parameters at their initial values.

A research of available literature on optimum deviation for NRZ PCM/FM shows a variation ranging from $0.7f_B$ to $0.9f_B$. Kotelnikov (reference 1) and Smith (reference 2) derive the optimum deviation to be $0.715f_B$ for FSK. Experimentally, Aeronutronic (reference 3) found the optimum deviation to be $0.75f_B$ as did a study by Electro-Mechanical Research (EMR) (reference 4). At the other end of the range, Shaft (reference 5) calculated $0.796f_B$ and experimentally found $0.84f_B$ as the optimum values.

Perhaps one of the more likely reasons for the variation in optimum deviation is the method of bit detection. In this experiment a $0.75f_B$ matched filter/sample detector in bit synchronizer A resulted in optimum deviations of $0.8f_B$ for NRZ and $1.6f_B$ for DM. An integrate and dump detector (square PCM matched filter) also in bit synchronizer A was tested for NRZ and gave $0.9f_B$ as optimum. Bit synchronizer B with a square PCM matched filter detector was also tested. Bit synchronizer B resulted in an optimum deviation of $0.9f_B$ for NRZ and $1.8f_B$ for DM. Aeronutronic's optimum of $0.75f_B$ (NRZ) was with an integrating detector. They also used a sampling detector that resulted in an optimum of $0.9f_B$ (NRZ). Kotelnikov and Smith's optimum was derived for coherently detected FSK, whereas Shaft's optimum was determined using discriminator detection. The reason for the variation of optimum deviation with bit detector was not investigated, but, as shown in figures 2 and 3 and discussed later, the degradation in BEP due to a non-optimum deviation setting is not severe if maintained near optimum.

It was found that the optimum deviation is independent of the premodulation filter bandwidth but dependent upon IF bandwidth and IF signal-to-noise ratio (SNR). From figures 2 and 3 it appears that the optimum deviation increases roughly 10 percent at low IF SNR due to AGC action and/or changing IF filter characteristics (not all receivers exhibit this phenomena). However, this change causes a relatively insignificant increase in BEP and can probably be ignored.

The dependence of optimum deviation on IF bandwidth can be related to the RF signal and noise power spectrums. Figure 4(a) shows the RF signal spectrum with optimum RF deviation for a 500 kHz IF filter bandwidth ($f_B = 500$ kb/s). The IF bandwidth was doubled, and the optimum deviation was found no longer to be $0.8f_B$ but increased to $1.09f_B$ as shown in figure 4(c). Doubling the IF bandwidth doubled the noise power to the demodulator (assuming white noise), but as shown in a 1 MHz bandwidth of figure 4(a), the signal power contributed by the introduction of the second sidebands into the IF passband did not double the total signal power to the demodulator. Therefore, as a result of decreased IF SNR, the BEP increased. However, the doubled IF bandwidth then allowed the deviation to be increased up to $1.09f_B$ without BEP degradation due to intermodulation distortion (filter phase nonlinearities) and forced FM thresholding (signal amplitude limiting by IF filter skirts). Increasing the deviation improves the receiver's video SNR and decreases the BEP. It does not increase the IF SNR. In fact, due to constant transmitter power, the spreading of the RF spectrum by increasing the deviation will lower the IF SNR by removing signal power from the passband. This power loss is not as significant as the improved video SNR, so consequently the net result is to lower the BEP as the deviation is increased to $1.09f_B$. Beyond $1.09f_B$, the BEP begins to increase again due to intermodulation distortion, signal power loss, and forced FM thresholding.

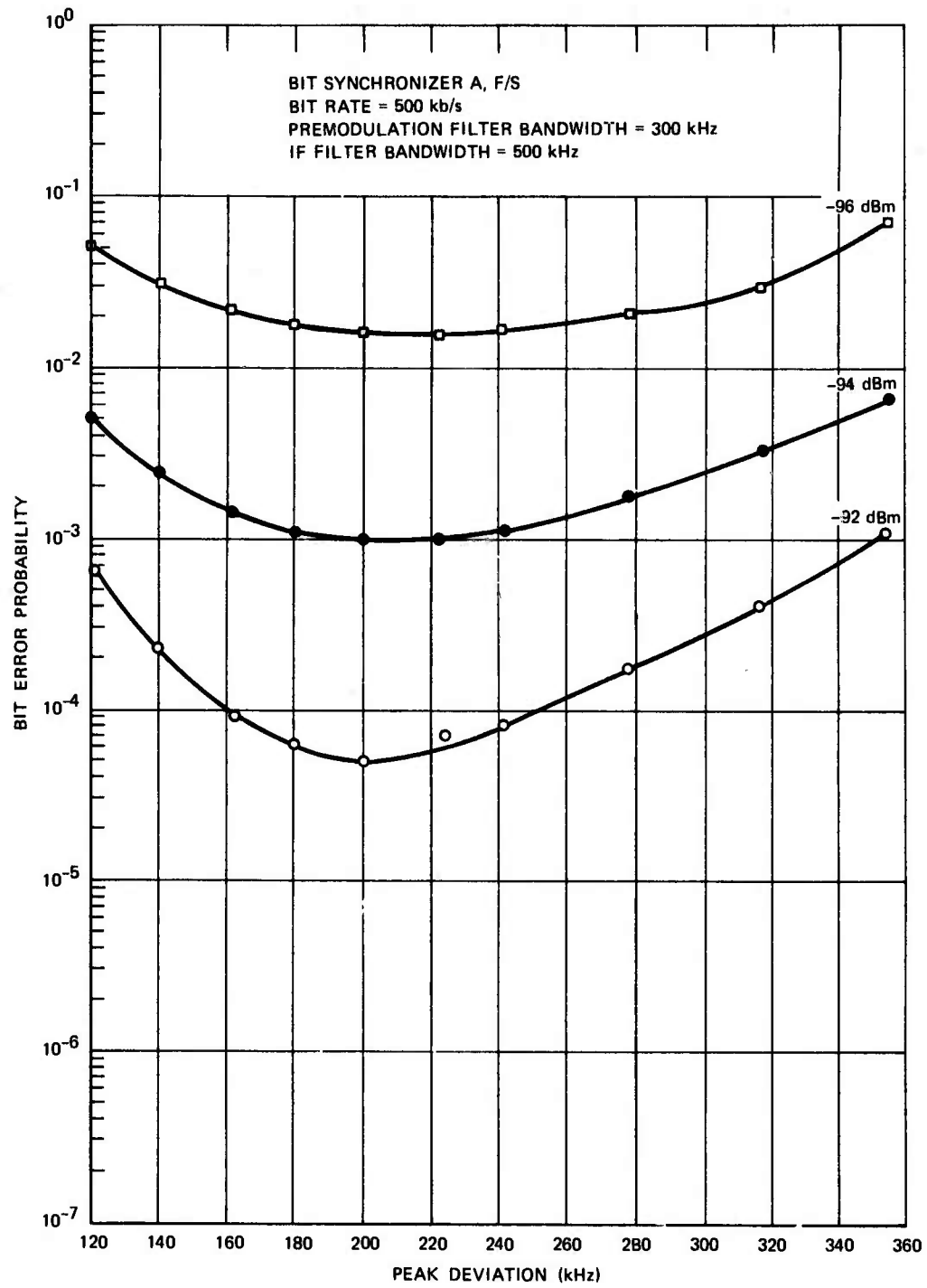

Figure 2. BEP Variations With RF Deviation for NRZ PCM/FM.

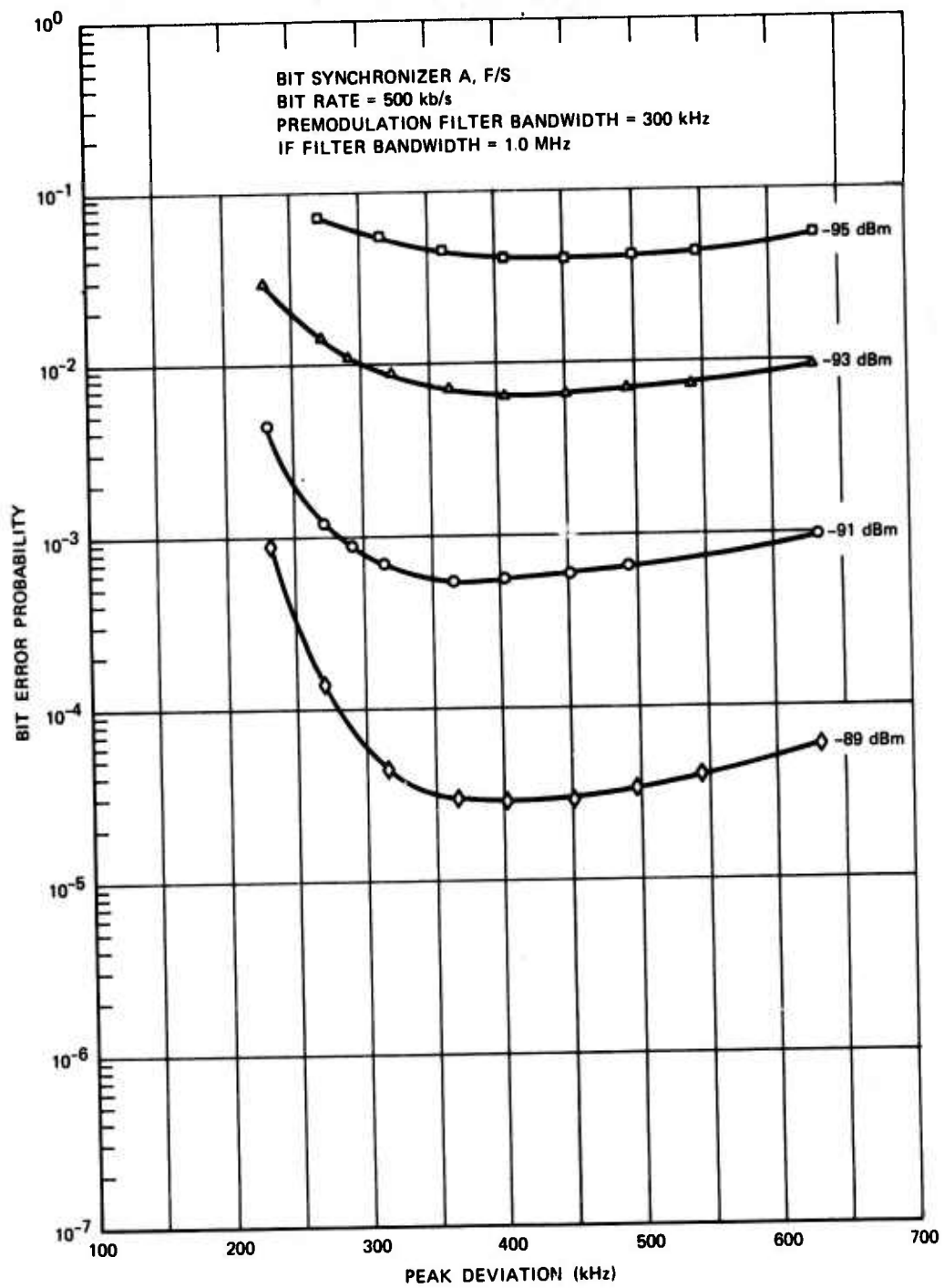
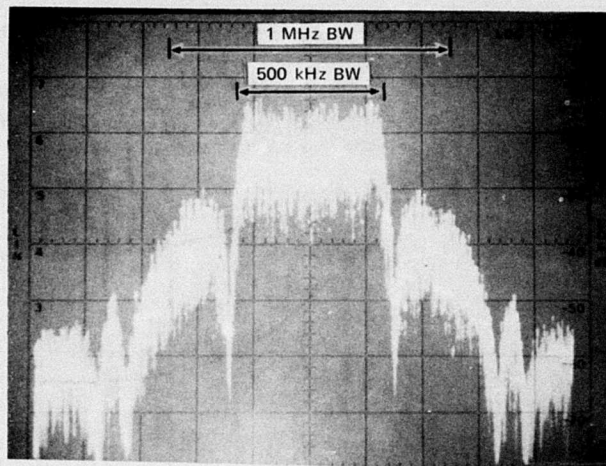

Figure 3. BEP Variations With RF Deviation for D_N PCM/FM.

BIT SYNCHRONIZER A, F/S
500 kb/s NRZ
500 kHz PREMODULATION FILTER
200 kHz/DIVISION
 $0.8 f_B$ PEAK-TO-PEAK DEVIATION



(a)

BIT SYNCHRONIZER A, F/S
500 kb/s NRZ
500 kHz PREMODULATION FILTER
200 kHz/DIVISION
 $0.53 f_B$ PEAK-TO-PEAK DEVIATION

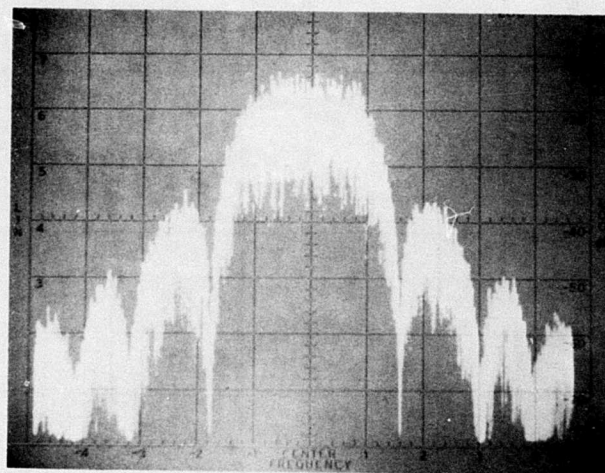

(b)

Figure 4. NRZ RF Signal Spectra.

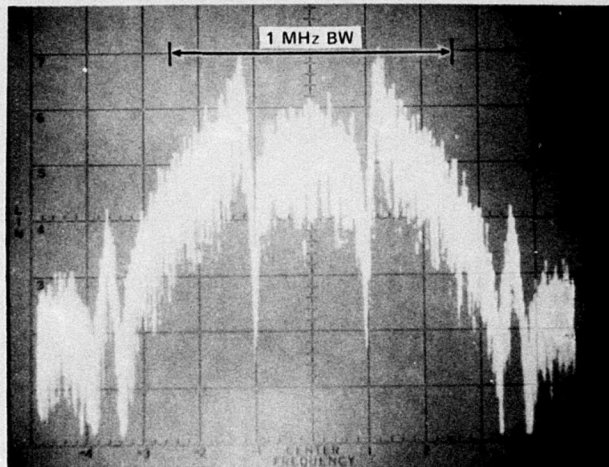

BIT SYNCHRONIZER A, F/S
 500 kb/s NRZ
 500 kHz PREMODULATION FILTER
 200 kHz/DIVISION
 1.09 f_B PEAK-TO-PEAK DEVIATION

(c)

Figure 4. (Concluded).

Obviously, if the IF bandwidth is halved from the 500 kHz of figure 4(a), the BEP will increase because of IF filter phase nonlinearities and forced FM thresholding. Reducing the deviation to remove these effects will lower the BEP. The experimental NRZ data in table 2 shows the optimum deviation for various IF bandwidths. All that remains in order to specify the optimum deviation is to determine the optimum IF bandwidth.

Table 2. NRZ Optimum Deviations for Various IF Filter Bandwidths

Bit Rate (kb/s)	IF Filter Bandwidth (kHz)	Peak-to-Peak Deviation Ratio	Bit Synchronizer
100	100	0.77	A (F/S)
100	200	0.83	A (F/S)
100	300	1.38	A (F/S)
100	500	3.37	A (F/S)
750	500	0.75	B (I/D)
750	750	0.90	B (I/D)
750	1,000	1.09	B (I/D)

IF Bandwidth

In the experiments conducted by Aeronutronics (reference 3) and EMR (reference 4), the optimum receiver bandwidth for NRZ was investigated and found to be equal to the bit rate, f_B . An unpublished report on DM by Dr. W. R. Hedeman of Aerospace Corporation indicates an optimum bandwidth of $2f_B$. Their experiments were not repeated for this report.

A verification of these optimum bandwidths was conducted by visually examining the RF spectrums of NRZ and DM at various RF deviations and with the premodulation filter bandwidth equal to the bit rate. The RF signal spectra of figures 4 and 5 were taken with f_B equal to 500 kb/s. Figures 4(a) and 5(a) show RF signal spectra with optimum deviations for the optimum RF bandwidths reported above. The spectra are roughly flat and constant over a bandwidth equal to the bit rate and signal power drops abruptly outside this bandwidth. The 3-dB points of the optimum filter are thus located at

BIT SYNCHRONIZER A, F/S
500 kb/s DM
500 kHz PREMODULATION FILTER
200 kHz/DIVISION
 $1.6 f_B$ PEAK-TO-PEAK DEVIATION

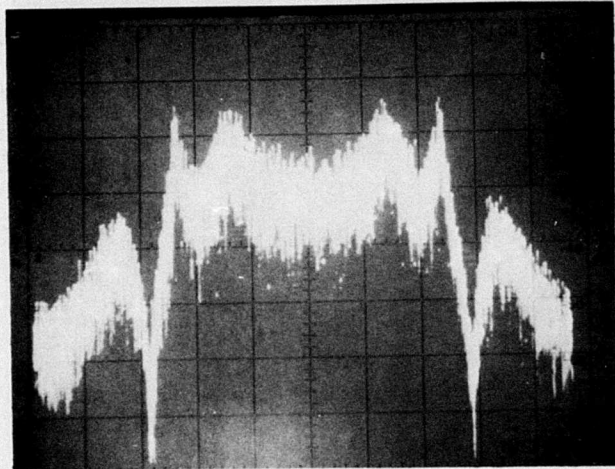

(a)

BIT SYNCHRONIZER A, F/S
500 kb/s DM
500 kHz PREMODULATION FILTER
500 kHz/DIVISION
 $1.04 f_B$ PEAK-TO-PEAK DEVIATION

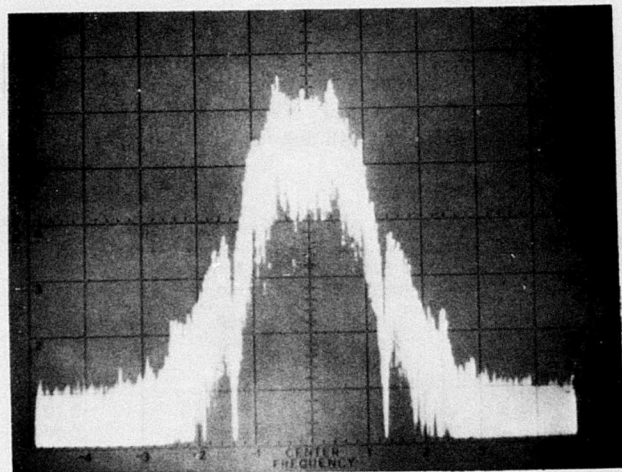

(b)

Figure 5. DM RF Signal Spectra.

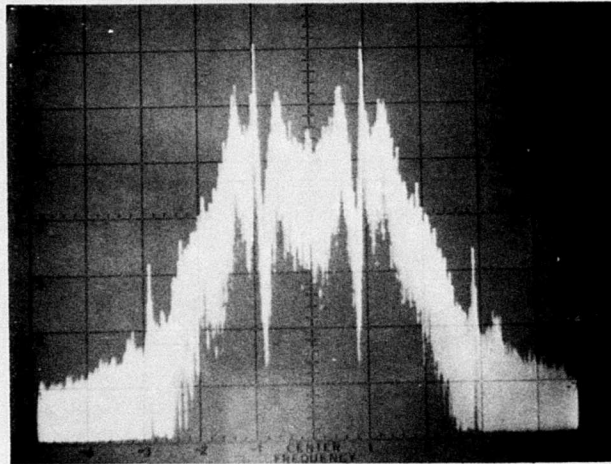

BIT SYNCHRONIZER A, F/S
 500 kb/s DM
 500 kHz PREMODULATION FILTER
 500 kHz/DIVISION
 $2.17 f_B$ PEAK-TO-PEAK DEVIATION

(c)

Figure 5. (Concluded).

a bandwidth equal to the bit rate for NRZ and twice the bit rate for DM; in this case, 500 kHz about center frequency for NRZ and 1,000 kHz about center frequency for DM. Both bandwidths encompass the first sidebands of the spectra where most of the signal power is concentrated. Larger bandwidths may allow more noise power than signal power into the IF passband and narrower bandwidths may unnecessarily restrict the signal causing intermodulation distortion and forced FM thresholding. Optimizing the RF deviation for a non-optimum IF bandwidth results in RF spectra such as those in figures 4(b) and 5(b) (narrower IF filter than optimum) and 4(c) and 5(c) (wider IF filter than optimum). These spectra are not as optimally distributed in the IF passband as in figures 4(a) and 5(a) and result in a higher BEP.

To illustrate the differences in BEP between optimum and non-optimum IF bandwidths and deviations, BEP variations with RF power were recorded and plotted in figures 6 and 7 for NRZ at 750 kb/s and for DM at 375 kb/s. BEP measurements were made using a 500 kHz, 750 kHz, and 1.0 MHz IF bandwidths with the RF deviation at optimum for 750 kHz and also with the RF deviation optimized for the non-optimum IFs. The results show severe BEP degradation for the narrower-than-optimum 500 kHz IF filter and an approximate 0.5 dB degradation for the wider-than-optimum 1.0 MHz filter for both NRZ and DM. Slight improvements in BEP were made by optimizing the RF deviation for the non-optimum IF filters, but the minimum BEP was still produced with the 750 kHz IF filter at a deviation of $0.9f_B$ (bit synchronizer B, I/D).

For data recording, the receiver IF bandwidth should be at least $2f_B$ for NRZ and $4f_B$ for DM to ensure no loss of signal because of IF clipping by signal drift. In such cases, the optimum RF deviation is set according to the total effective bandwidth of prerecording and post-recording IF's. Optimally, this effective bandwidth is set as close as possible to f_B for NRZ and $2f_B$ for DM.

Premodulation Filter Bandwidth

After setting the RF transmitter deviation and receiver IF bandwidth to the previously determined optimum values, the premodulation filter bandwidth was adjusted for minimum BEP. As expected, the optimum bandwidth was infinite for both NRZ and DM since signal energy per bit increases with

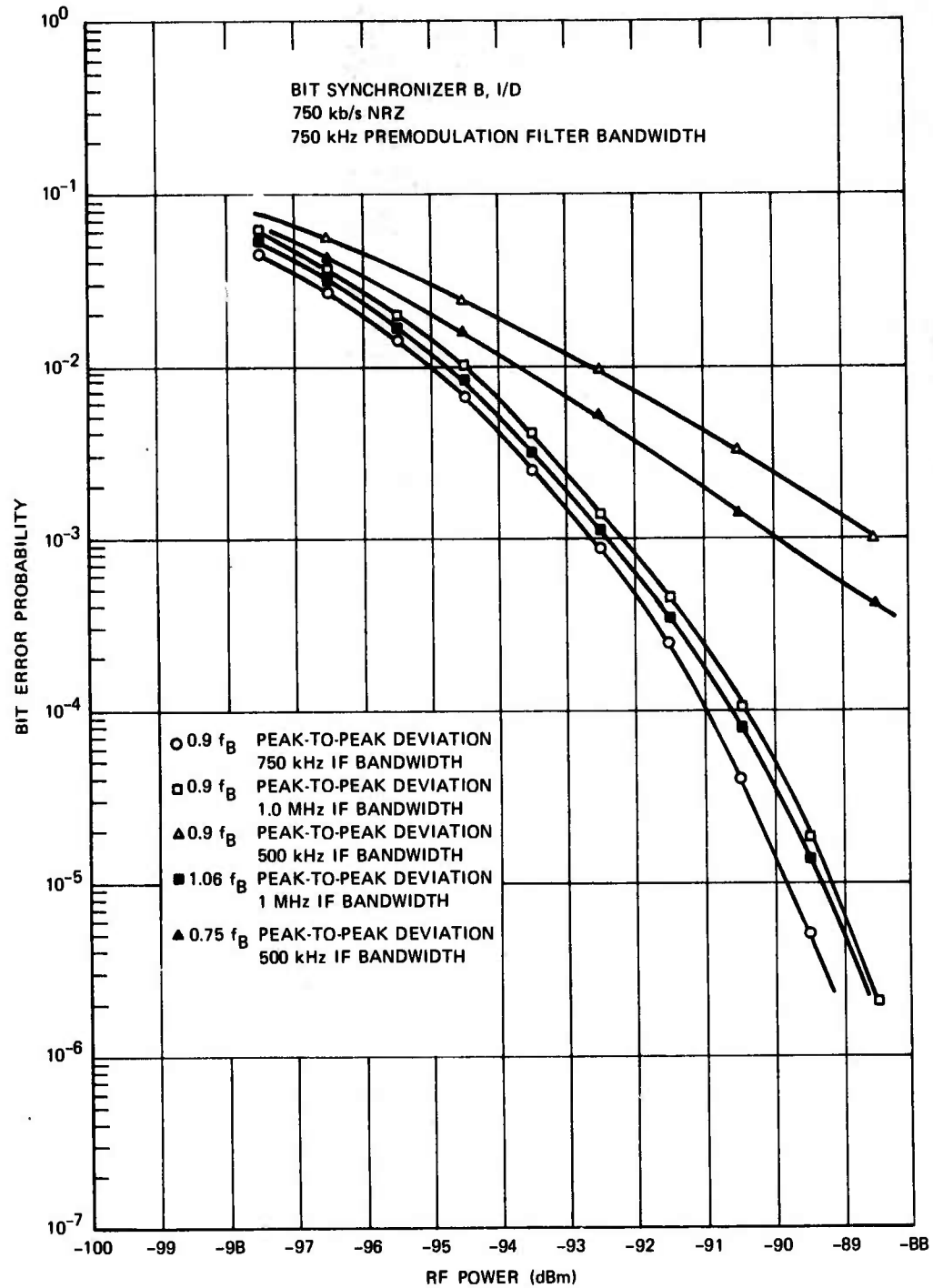

Figure 6. NRZ Bit Error Sensitivity to IF Filter Bandwidth.

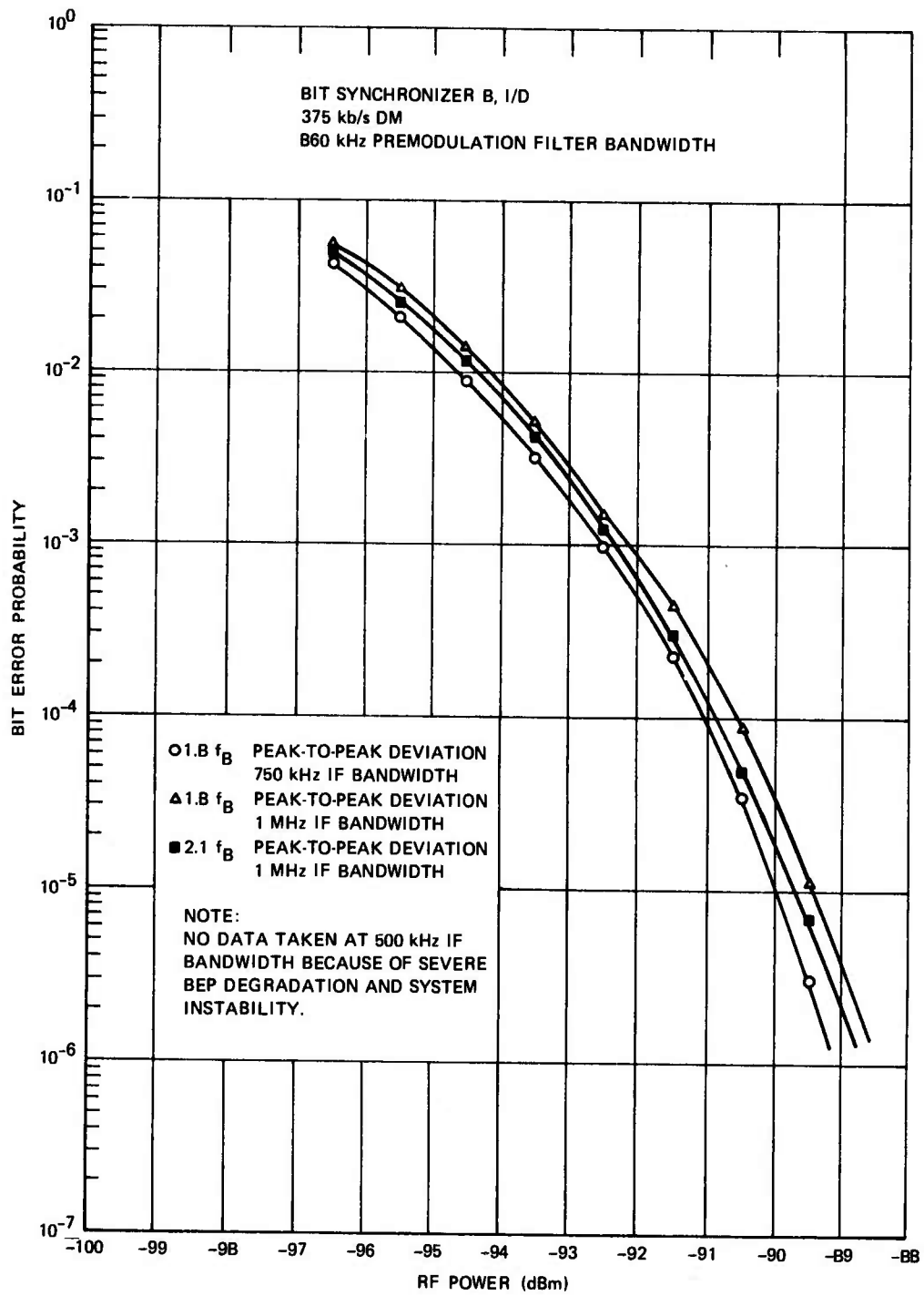

Figure 7. DM Bit Error Sensitivity to IF Filter Bandwidth.

bandwidth. However, the primary purpose of a premodulation filter is to limit RF spectral occupancy by attenuating the tails of the RF signal spectrum. Therefore a tradeoff of BEP for RF bandwidth is necessary. Figures 8 and 9 show the variation in BEP with premodulation filter bandwidth for f_B at 500 kb/s. Both figures suggest that the premodulation filter bandwidth should be set between $0.5f_B$ and $1.0f_B$. The relatively small losses in BEP for premodulation bandwidths as narrow as $0.5f_B$ are due to the band limiting of the IF filter. Since the sidebands of the RF signal spectrum are generally rejected by the IF filter, the premodulation filter should have little effect on BEP as long as its bandwidth is greater than $0.5f_B$ and the IF filter bandwidth is at optimum. Bandwidths less than $0.5f_B$ will cause a loss of signal power in the baseband that begins to severely degrade the BEP. A wider bandwidth than $1.0f_B$ will result in a relatively insignificant decrease in BEP because of the optimum IF filter's band limiting but will increase the RF bandwidth.

Figures 10 and 11 illustrate the difference in BEP between a premodulation filter set at $0.5f_B$ and $1.0f_B$ for f_B equal to 500 kb/s and with optimum IF bandwidths and RF deviations. The BEP variations with RF power were determined by incrementally varying the FM signal generator's attenuator and recording the attenuation and the BEP. RF power was calibrated to the attenuator by measuring high RF power levels at the receiver input with an RF power meter. There was a 0.4 to 0.6 dB improvement in BEP for NRZ using a 500 kHz premodulation filter over a 250 kHz premodulation filter and a 0.4 dB improvement for DM. At the non-optimum deviations in figures 10 and 11, the improvement was 1 dB for both NRZ and DM.

RF Bandwidth

IRIG document 106-73, Telemetry Standards, lists three RF channel bandwidths in the L- and S-band frequency ranges; they are 1.0 MHz, 3.0 MHz, and 10.0 MHz in width. These channel bandwidths are equivalent, as defined by IRIG, to RF signal bandwidths of 1.2 MHz, 3.2 MHz, and 10.2 MHz, respectively, where the signal is 60 dB down from the unmodulated carrier at the band edge. At each of several bit rates (with pseudo-random data), the premodulation filter was varied and the RF transmitter deviation held fixed at optimum to find the maximum allowable premodulation filter bandwidth that would still restrict the RF signal bandwidth to within one of the IRIG channels. Figure 12 defines approximate maximum premodulation filter bandwidths for various NRZ and DM bit rates such that the RF spectra remain within a 1.0 MHz or 3.0 MHz channel. Bandwidth limitations on the premodulation filter and the modulation section of the RF signal generator did not permit 10.0 MHz channel measurements. The RF signal spectrum width will vary with the NRZ or DM formatting and shift with transmitter drift; thus the premodulation filter was always set such that the RF signal was down 60 dB at the band edges of the IRIG channels. This left 100 kHz of bandwidth on either side of the signal spectrum to allow for spectrum variations and drift.

The lower diagonal line in figure 12 represents the lower limit on premodulation filter bandwidth as defined by $0.5f_B$. Thus the approximate highest bit rate in which the RF spectrum will remain in a 1.0 MHz channel is roughly 350 kb/s for pseudo-random NRZ and 220 kb/s for pseudo-random DM. For a 3.0 MHz channel, the highest bit rates are approximately 1.0 Mb/s for NRZ and 720 kb/s for DM. Higher and lower bit rates may be possible depending on the data sequence. For lower bit rates than these maximums, it is recommended that the premodulation filter be set as wide as possible, up to $1.0f_B$, without the RF signal spectrum exceeding an IRIG channel. While larger premodulation bandwidths are possible, they do not give a significant decrease in BEP for the increase in RF bandwidth. As an example, consider a 500 kb/s NRZ signal, figure 12 indicates that the premodulation filter can be set from 250 kHz to 850 kHz and still remain in the 3 MHz channel. Figure 10 shows a 0.4 to 0.6 dB improvement in BEP with a 500 kHz filter over a 250 kHz filter but no improvement over the 500 kHz filter with a 869 kHz filter.

If for a particular bit rate the RF spectrum is marginally within its RF channel and the premodulation filter is at $0.5f_B$, then it is possible to decrease the RF bandwidth by decreasing the RF transmitter deviation. By using figures 2 and 3, limits can be set on a permissible range of RF transmitter

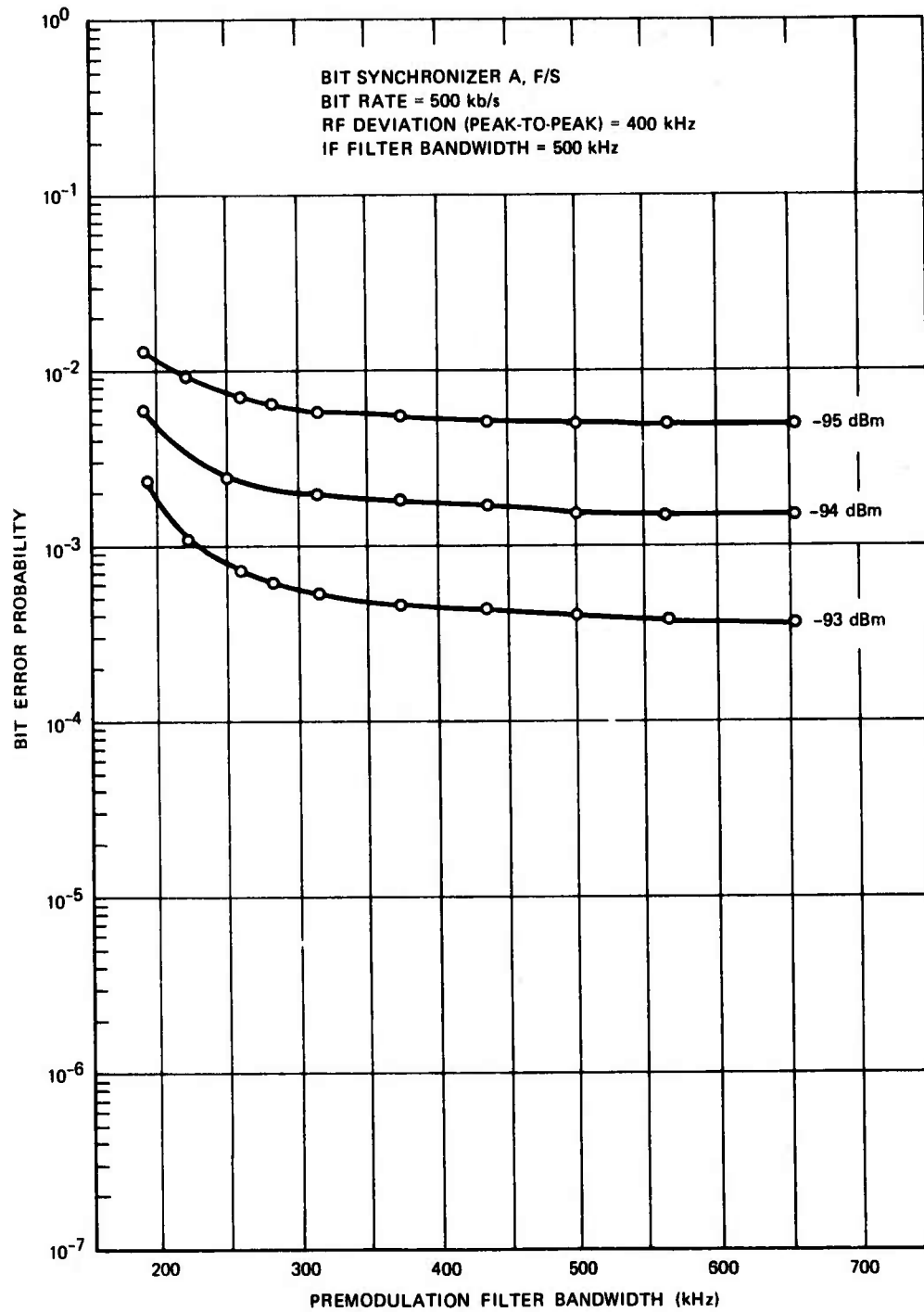

Figure 8. NRZ BEP Variations With Premodulation Filter Bandwidth.

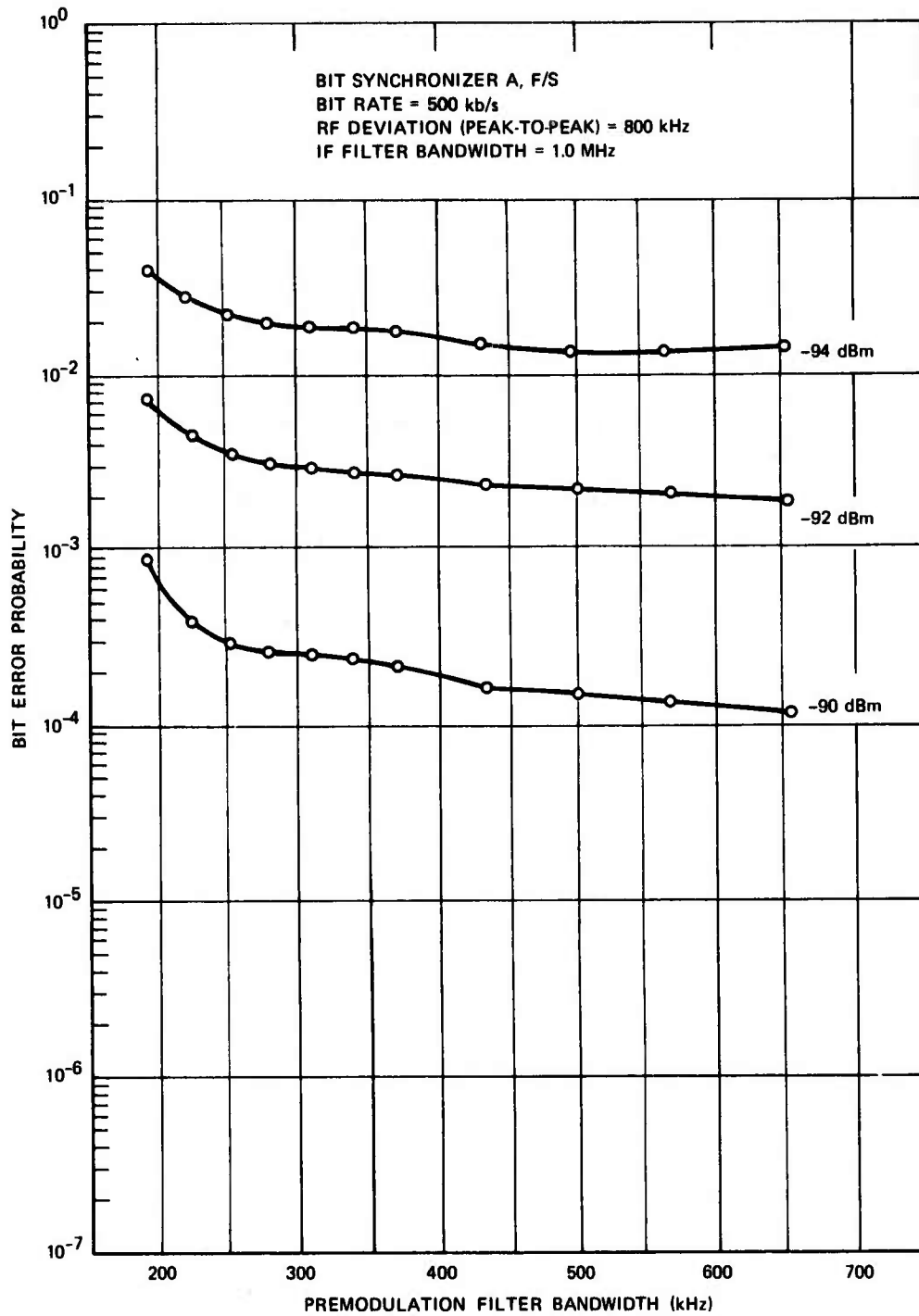

Figure 9. DM BEP Variations With Premodulation Filter Bandwidth.

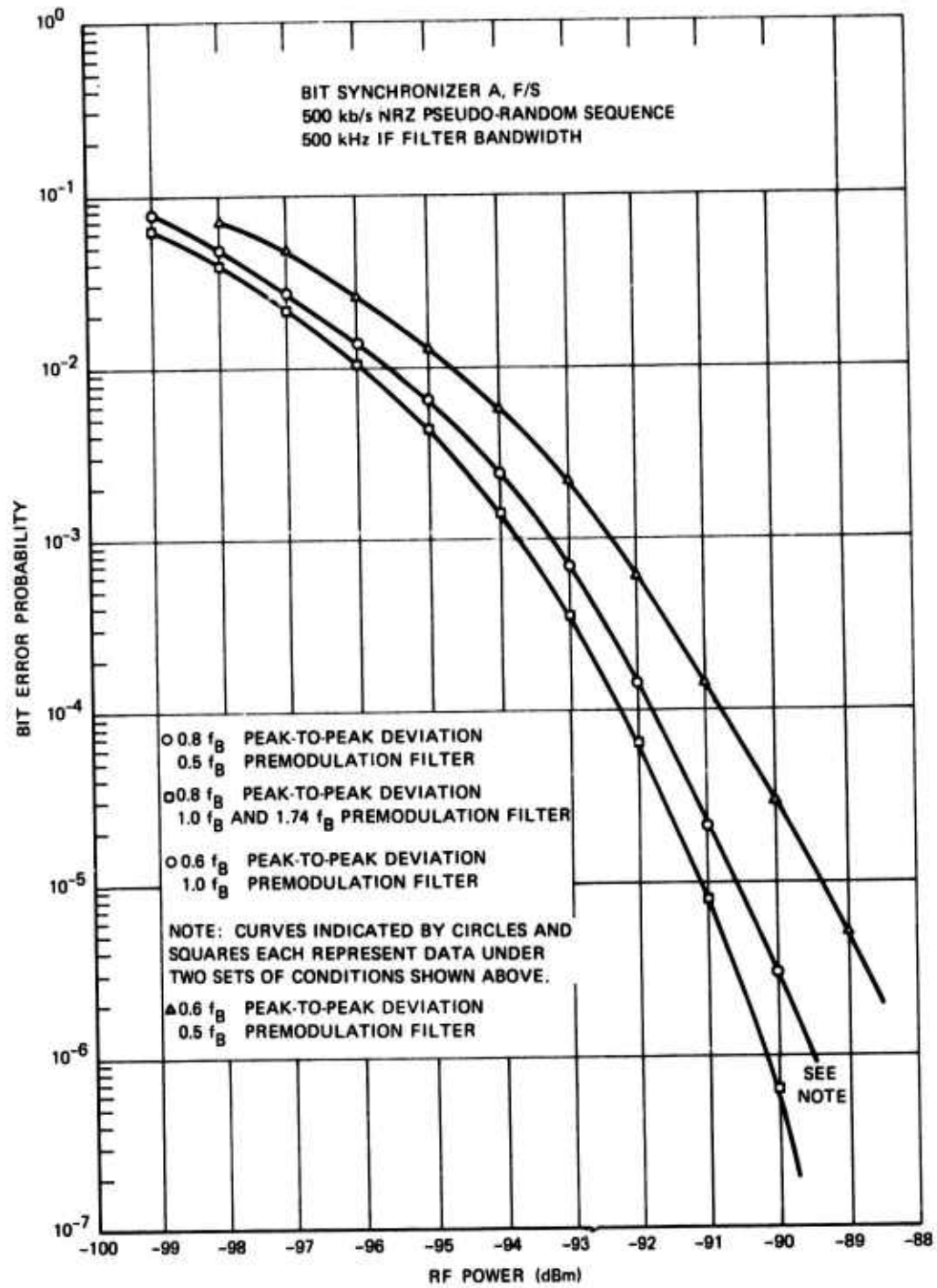

Figure 10. NRZ BEP Sensitivity to RF Deviation and Premodulation Filter Bandwidth.

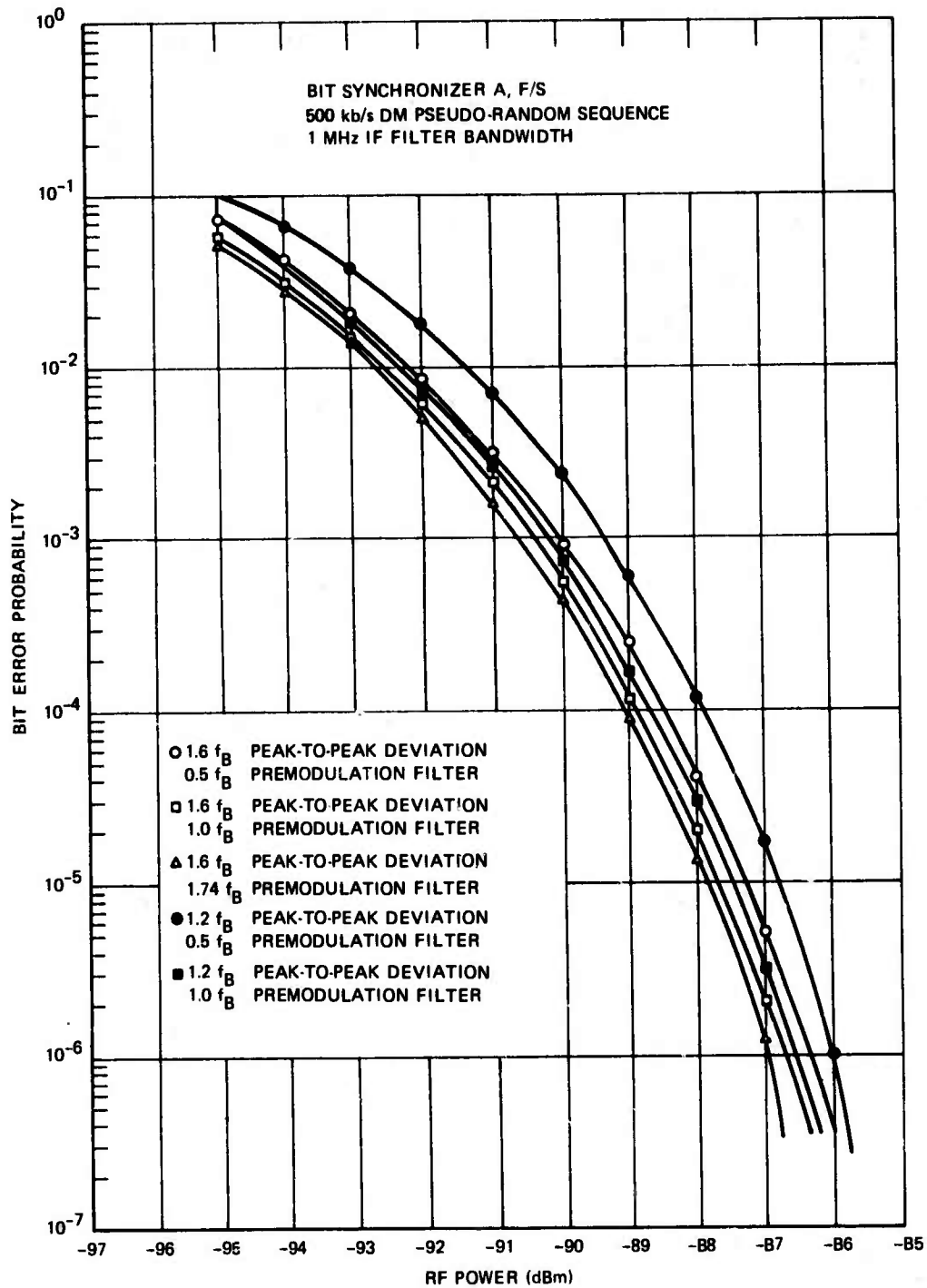

Figure 11. DM BEP Sensitivity to RF Deviation and Premodulation Filter Bandwidth.

PSEUDO-RANDOM BIT SEQUENCE

- NRZ ○ 1 MHz CHANNEL
- NRZ ● 3 MHz CHANNEL
- DM □ 1 MHz CHANNEL
- DM ■ 3 MHz CHANNEL

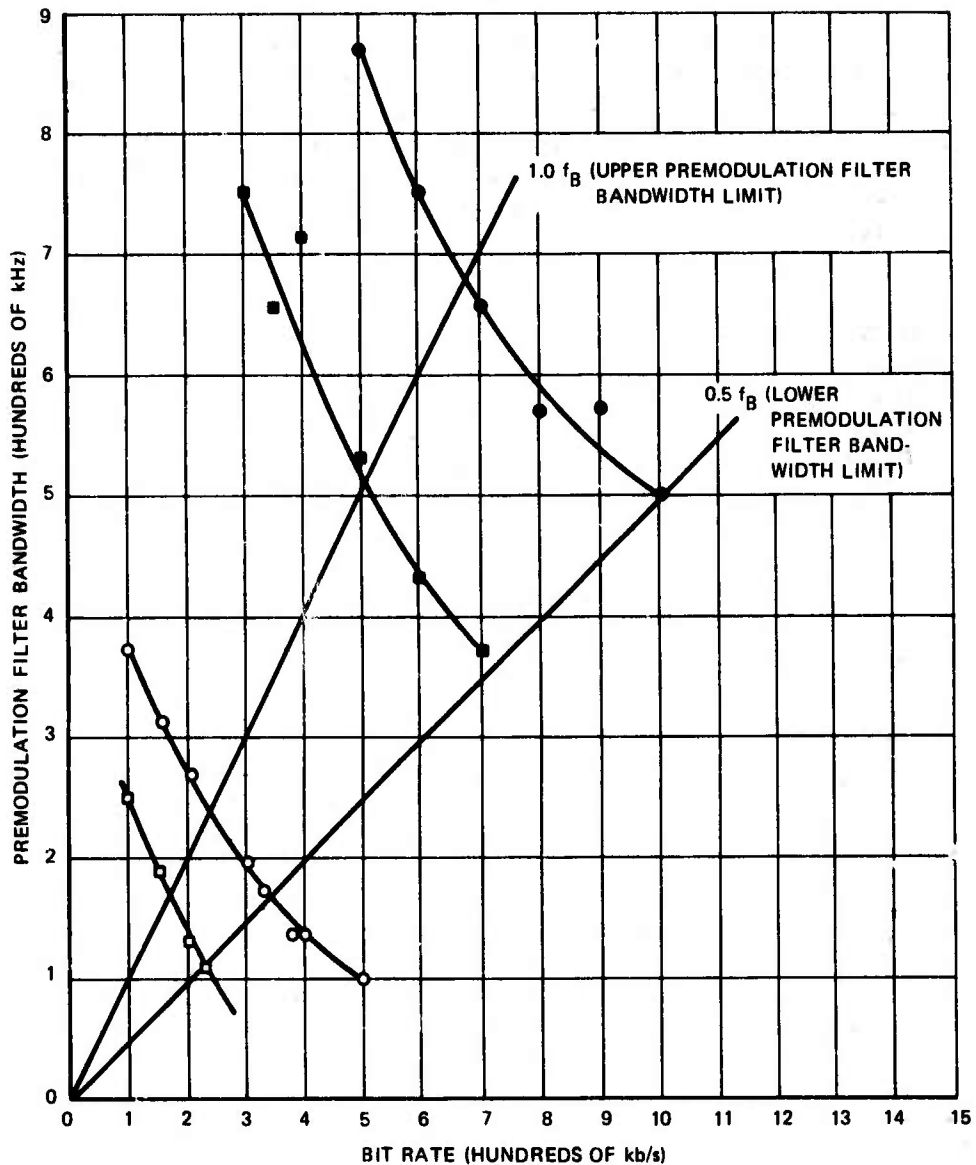

Figure 12. Bit Rates Containable in 1 MHz RF Channel Bandwidths by Band Limiting With a Premodulation Filter.

deviation; the proposed limits are $0.6f_B$ to $0.9f_B$ for NRZ and $1.2f_B$ to $1.8f_B$ for DM. Within these limits, the BEP has been slightly degraded from that at the upper limit for a small decrease in RF bandwidth. Exceeding the upper limit increases not only the BEP but the RF bandwidth too, whereas dropping below the lower deviation limit begins to significantly increase the BEP for any further bandwidth savings. For the deviation ranges proposed above, an RF bandwidth savings of 100 to 200 kHz for NRZ and 200 to 400 kHz for DM can be realized if required.

Figures 10 and 11 show the tradeoff in BEP that results when decreasing the RF transmitter deviation to save RF bandwidth. With the premodulation filter at $0.5f_B$, there was a 1.0 to 1.2 dB improvement in NRZ BEP when using the optimum deviation of $0.8f_B$ compared to using the lower deviation limit of $0.6f_B$ and a 0.4 to 0.6 dB improvement with the premodulation filter at $1.0f_B$. With the premodulation filter set at $0.5f_B$, there was a 0.6 to 0.8 dB improvement in DM BEP using the optimum deviation of $1.6f_B$ instead of the lower deviation limit of $1.2f_B$ and a 0.2 dB improvement with the premodulation filter at $1.0f_B$.

NRZ AND DM

A description of the two PCM formats is given in figure 13 (see reference 6). Because of mid-bit transitions, DM is at twice the clock rate of NRZ. The optimum system parameters reflect this difference in RF deviation and IF bandwidth which for DM are twice those of NRZ; i.e.,

	NRZ		DM	
	F/S	I/D	F/S	I/D
P-P RF Transmitter Deviation	$0.8f_B$	$0.9f_B$	$1.6f_B$	$1.8f_B$
IF Filter Bandwidth (or equivalent pre- and post-recording IF BW)	$1.0f_B$	$1.0f_B$	$2.0f_B$	$2.0f_B$
Premodulation Filter Bandwidth	$0.5f_B$ to $1.0f_B$	$0.5f_B$ to $1.0f_B$	$0.5f_B$ to $1.0f_B$	$0.5f_B$ to $1.0f_B$

Figures 14 and 15 compare the video spectra of two PCM formats, and figure 16 compares the BEPs of 500 kb/s NRZ and DM under their optimum conditions. Figure 16 shows that the BEP for NRZ is approximately 3 dB better than for DM. This result agrees with those results reached by Dr. W. R. Hedeman of Aerospace Corporation in an unpublished report and by Dr. W. C. Lindsey of Southern California University in reference 6. Both reports conclude that, for a selected BEP, a given telemetry link can support twice the bit rate when NRZ is used as compared to the use of DM. This is experimentally verified by figures 6 and 7 where NRZ is twice the DM bit rate.

SUMMARY OF RESULTS

Optimum conditions for transmission of PCM/FM in general depend on the PCM code, the bit rate, the RF channel bandwidth, and system equipment. Optimum conditions are those system parameter values that minimize the BEP, subject to RF bandwidth requirements and system tolerances (i.e., transmitter and receiver drift). It was found that the optimum IF filter bandwidth is equal to the bit rate for NRZ and twice the bit rate for DM. However, under other than laboratory conditions, a wider-than-optimum IF bandwidth may be necessary because of the standard fixed IF filter sizes or because of transmitter and receiver drift. In fact, it is recommended that for tape-recording purposes, the receiver IF bandwidth be set wider than optimum to avoid IF clipping from signal drift and that a narrower filter bandwidth be used for data playback.

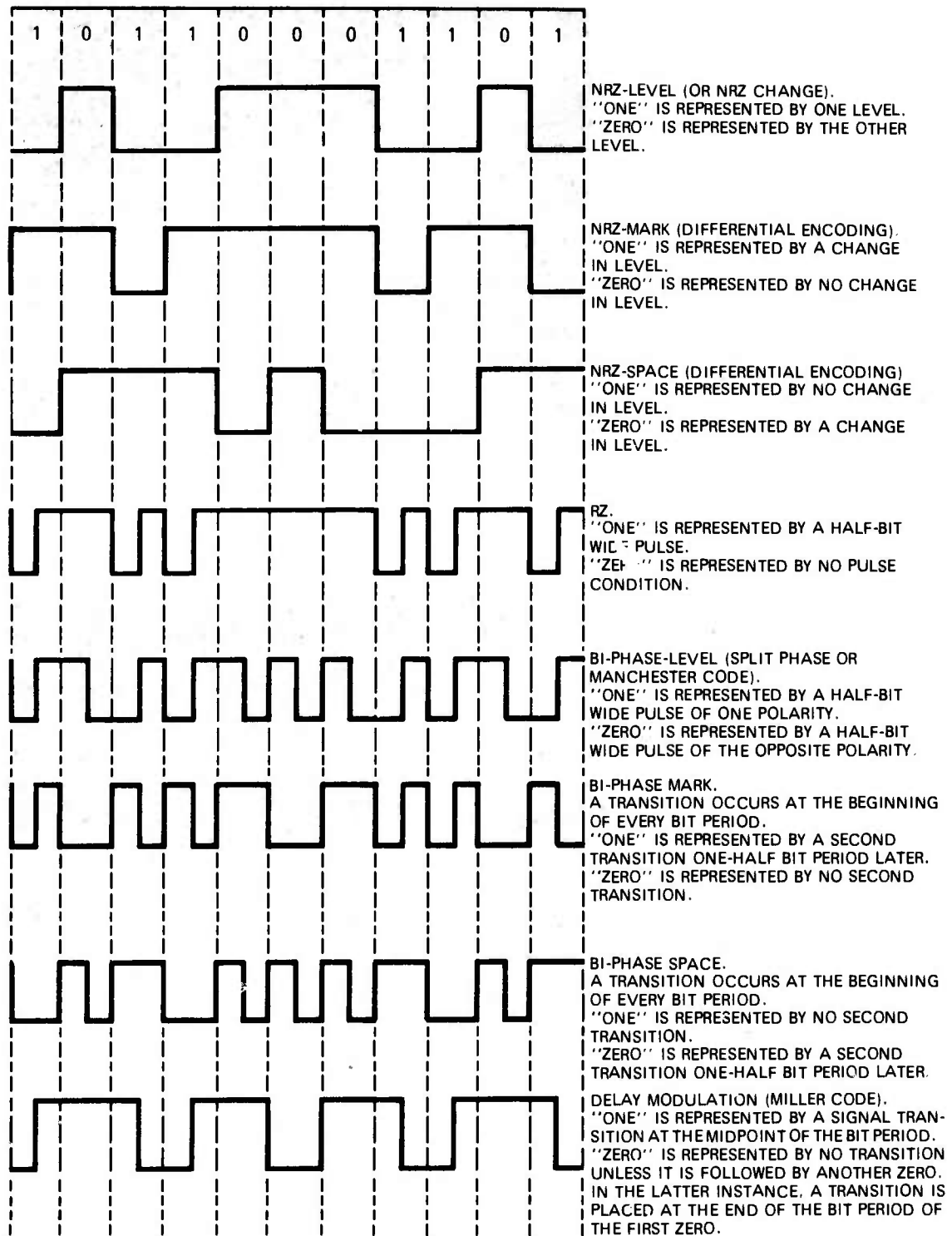
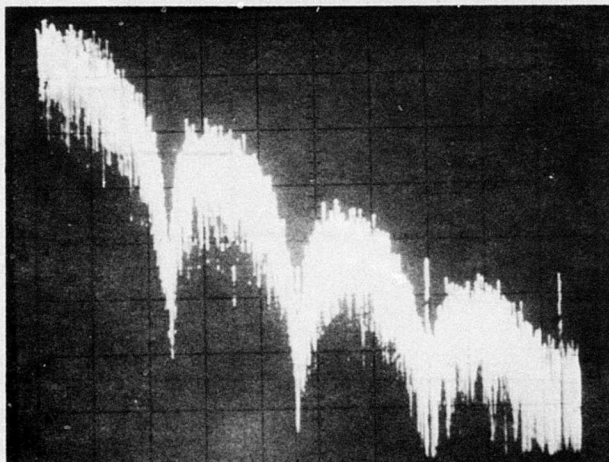

Figure 13. PCM Signaling Formats.

500 kb/s NRZ
500 kHz PREMODULATION FILTER
200 kHz/DIVISION



(a)

500 kb/s NRZ
250 kHz PREMODULATION FILTER
200 kHz/DIVISION

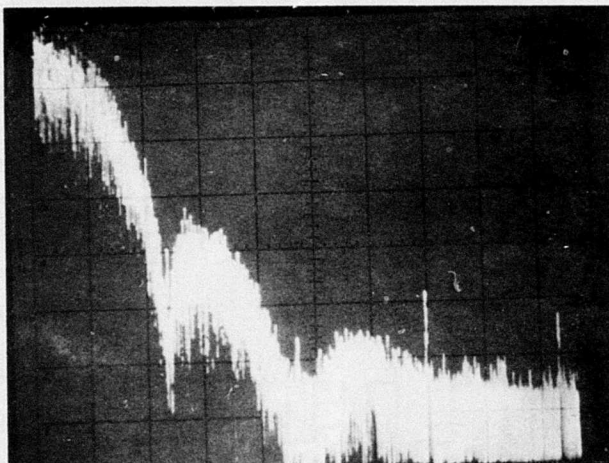

(b)

Figure 14. NRZ PCM Video Spectra of a Pseudo-Random Pattern.

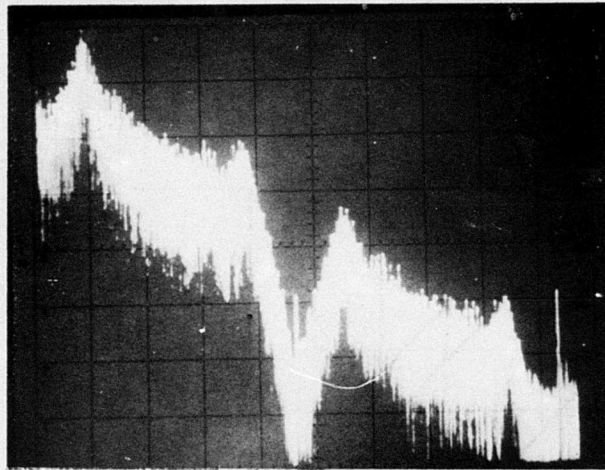

500 kb/s DM
500 kHz PREMODULATION FILTER
200 kHz/DIVISION

(a)

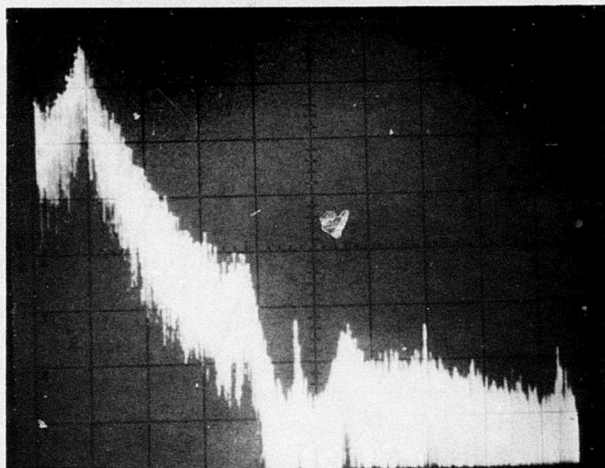

500 kb/s DM
250 kHz PREMODULATION FILTER
200 kHz/DIVISION

(b)

Figure 15. DM PCM Video Spectra of a Pseudo-Random Pattern.

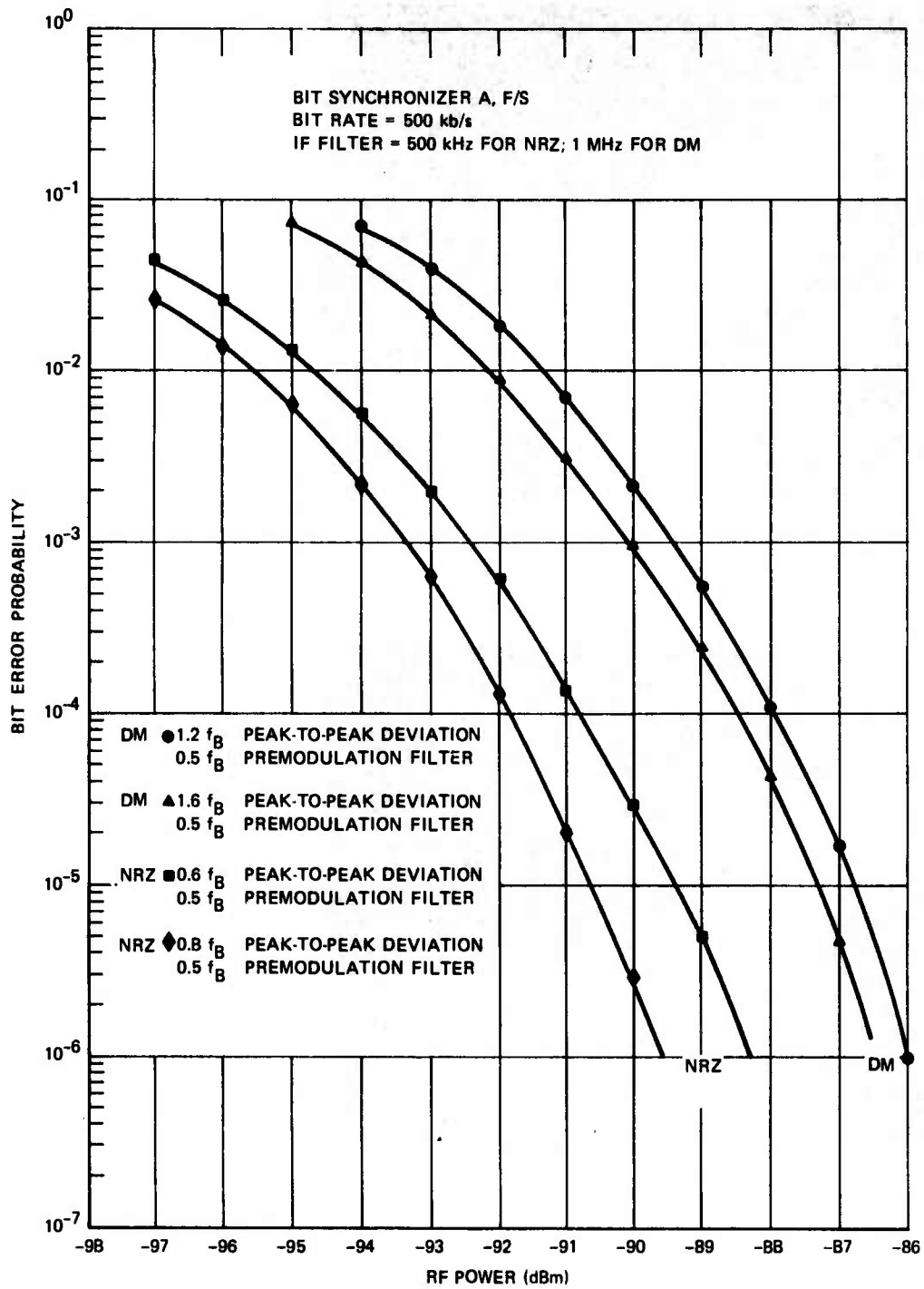

Figure 16. Comparison of Optimum NRZ and DM PCM/FM Bit Error Probabilities.

The optimum deviation is that deviation which minimizes the BEP within RF channel constraints. The optimum peak-to-peak RF deviation was found to depend upon IF filter bandwidth and bit detection equipment. Theoretical and experimental data (see references 1 through 5) indicate that the optimum deviation ranges from $0.7f_B$ to $0.9f_B$ for NRZ with an optimum IF filter bandwidth and may be higher for a wider-than-optimum IF filter.

The optimum premodulation filter bandwidth is a value which minimizes the BEP and keeps the RF spectral occupancy within requirements. Results show bandwidths less than $0.5f_B$ begin to severely raise the BEP and that bandwidths greater than $1.0f_B$ offer very little gain in terms of BEP. Because the premodulation filter's primary purpose is to bandlimit the RF signal spectrum, it should be associated with RF channel bandwidths as well as the bit rate.

Obviously, optimum conditions for data transmission can take on a wide range of values. Rather than attempting to achieve maximum performance from a system by determining optimum conditions for every requirement, rules of thumb for setting system parameters can be established for all systems in noncritical applications with only a moderate loss (~2 dB) in BEP. That is, many telemetry system applications must tolerate non-optimum operation to some degree. For these applications, rules of thumb may be used to facilitate the determination of system parameters. Such rules were given earlier in this report under Test Methods and Results. In general, the parameter values given by various rules of thumb should fall within the following ranges:

1. The receiver IF bandwidth should be at least twice the optimum for data-recording purposes. The equivalent bandwidth of the prerecording and post-recording IF combination should be close to f_B but less than $2f_B$ for NRZ and close to $2f_B$ but less than $4f_B$ for DM.
2. The peak-to-peak RF transmitter deviation should lie between $0.6f_B$ and $0.9f_B$ for NRZ and between $1.2f_B$ and $1.8f_B$ for DM.
3. The premodulation filter bandwidth should fall between $0.5f_B$ and $1.0f_B$ for both NRZ and DM.

This investigation verifies the conclusions of Dr. Lindsey (reference 6) and Dr. Hedeman that for equivalent bit rates under their optimum transmission conditions NRZ is 3 dB better than DM; for equivalent BEP, the bit rate of NRZ is approximately twice that of DM. Thus DM is not recommended for applications of maximum data transfer over a bandlimited RF system where noisy signals may be received.

REFERENCES

1. Kotelnikov, V. A. "The Theory of Optimum Noise Immunity." McGraw-Hill, N Y., 1960.
2. Smith, E. F. "Attainable Error Probabilities in Demodulation of Random Binary PCM/FM Waveforms;" IRE Transactions on Space Electronics and Telemetry. Vol. SET-8 (Dec 1962) pp. 290-7.
3. "Telemetry System Study" Final Report, Aeronutronic Publication U-743 (Dec 1959); U.S. Army Signal Research and Development Laboratories Contract No. DA-36-039 (SC-73182) Proj. No. 3-16-00-300.
4. Electro-Mechanical Research Inc. "Experimental Determination of Signal-to-Noise Relationships in PCM FM and PCM PM Transmission," by L. R. Brown. NASA Contract NAS 5-505, 20 Oct 61.
5. Shaft, P. D. "Error Rate of PCM-FM Using Discriminator Detection," IEEE Transactions on Space Electronics and Telemetry: Vol. SET-9 Dec 1963. pp. 131-7.
6. Naval Missile Center. Bit Synchronization System Performance Characterization, Modeling, and Tradeoff Study, by W. C. Lindsey. Point Mugu, California. 4 Sep 1973 (Technical Publication TP-73-18) UNCLASSIFIED.

INITIAL DISTRIBUTION

EXTERNAL	Copies	EXTERNAL	Copies
Commander Naval Air Systems Command Headquarters Washington, DC 20361 Attn: AIR-954 AIR-6502	2 1	Commander Naval Weapons Center China Lake, CA 93555 Attn: Code 373 Code 374 Code 533 Code 3742 (R.E. Rockwell) Code 451 (K.D. Cox)	1 1 1 1 1
Defense Documentation Center Cameron Station Alexandria, VA 22314 Attn: TIOG	2	Commander Naval Air Test Center Telemetry Data Center TDS/TSD Patuxent River, MD 20670 Attn: H.O. Norfolk, Jr.	4
Commander Naval Sea Systems Command Headquarters Washington, DC 20362 Attn: SEA-653 SEA-6543	1 1	Commander U.S. Naval Ordnance Missile Test Facility White Sands Missile Range, NM 88002 Attn: Code 503 (W.W. Bohn)	1
Commanding Officer U.S. Naval Station Atlantic Fleet Weapons Range Box 545 FPO New York 09551 Attn: H. T. Herring	1	DDR&E AD(TR) The Pentagon Washington, DC 20301 Attn: J. A. Webster	1
Commanding Officer Naval Avionics Facility 21st and Arlington Avenue Indianapolis, IN 46218 Attn: Code 906 Code 814 J. Brining Code 814 K. Burgess	1 1 1	Director of Navy Ranges and Targets Point Mugu, CA 93042 Attn: AIR-630 AIR-6302 AIR-6302D	1 1 1
Officer-in-Charge Fleet Analysis Center Naval Weapons Station, Seal Beach Corona, CA 91720 Attn: Code 851 Code 8513 Code 8522	1 1 1	Commanding Officer Yuma Proving Ground Yuma, AZ 85364 Attn: STEYP-MDP (H. S. McElfresh)	1
Commanding Officer Naval Ship Weapons Systems Engineering Station Port Hueneme, CA 93043 Attn: Code 4920 (C.B. Tendick)	1	Commanding Officer Ballistic Missile Defense Systems Command PO Box 1500 Huntsville, AL 35807 Attn: BMDSC-RD (G.E. Wooden) BMDSC-ROO (D.E. Parker)	1 1

EXTERNAL	Copies	EXTERNAL	Copies
PICATINNY Bldg 65, SMUPA-RX Dover, NJ 07801 Attn: Telemetry Division, TSD (J. C. Greenfield)	1	AFCRL - LCS L. G. Hanscom Field Bedford, MA 01730 Attn: C. H. Reynolds	1
Commanding Officer U.S. Army Missile Command Redstone Arsenal, AL 35809 Attn: AMSMI-RTA, Bldg. 7855 (R. D. Bibb)	1	SAMTEC Vandenberg AFB, CA 93437 Attn: SAMTEC - ENIT (D. K. Manoa) SAMTEC - ROOE (K. O. Schoeck)	1 1
Commanding Officer U.S. Army Electronic Proving Ground Fort Huachuca, AZ 85613 Attn: STEEP-MT-I (W.T. Lyon)	1	AFETR Patrick AFB, FL 32925 Attn: AFETR - ENIL (F. Mann)	1
Commanding General Department of the Army White Sands Missile Range, NM 88002 Attn: STEWS-ID-IT (B. Chin) (J. D. Cates) STEWS-ID-S (B. E. Norman) (E. Bejarno)	1 1 1 1	AFFTC Edwards AFB, CA 93523 Attn: AFFTC - DOESD (J. Ramos)	1
ADTC Eglin AFB, FL 32542 Attn: ADTC - TSGGS (E. J. Poschell) ADTC - TSGPG (B. L. Culberson) Vitro Services (R. L. Manley)	1 1 1	Sandia Laboratories Kirtland AFB East Albuquerque, NM 87115 Attn: Division 1251 (R. S. Reynolds) Division 9486, Box 5800 (P. L. Walter) Division 9421, Box 5800 (H. O. Jeske)	1 1 1 1
AFSWC Holloman AFB, NM 88330 Attn: 6585 TG/TKIA (J. A. Haden)	1	AFSCF Sunnyvale, CA 94086 Attn: Det 1, AFSCF - DOZR (G. V. Kreider)	1
AFSWC Kirtland AFB, NM 87115 Attn: AFSWC - TED (CAPT R. J. Skelton) 4900 TG/FTEI (J. C. Scott)	1 1	AFSCF Aerospace Corporation P.O. Box 92957 Los Angeles, CA 90009 Attn: C. Nakamura Bldg. 115/1341	1
		National Bureau of Standards Electronic Division Bldg. 225, Room A109 Gaithersburg, MD 20760 Attn: GSA-FSS (J. J. Fiori)	1

EXTERNAL	Copies	EXTERNAL	Copies
National Bureau of Standards Washington, DC 20234 Attn: Div. 425.03 (P. S. Lederer)	1	EMR Telemetry P.O. Box 3041 Sarasota, FL 33578 Attn: S. Bass G. Tremain	1 1
Aerospace Corporation Suite 4040 955 L'Enfant Plaza S.W. Washington, DC 20024 Attn: Dr. W. R. Hedeman	6	Federal Electric Corporation Vandenberg AFB, CA 93437 Attn: R. Streich	1
National Aeronautics and Space Administration Goddard Space Flight Center Greenbelt, MD 20771 Attn: Code 730.4 (W. B. Poland, Jr.) Code 734 (R. M. Muller) (C. Trevathan)	2 1 1	Grumman Aerospace Corporation Instrumentation PLT 6 Calverton, NY 11933 Attn: R. S. McElhiney E. Charland	1 1
National Aeronautics and Space Administration 1520 H Street N.W. Washington, DC 20546 Attn: Code MF (W. E. Miller, Jr.)	1	Harris Electronic Systems Div. P.O. Box 37 Melbourne, FL 32935 Attn: C. Curry	1
Marshall Space Flight Center Huntsville, AL 35812 Attn: Code S&E-ASTR-I (W. Threlkeld)	1	IED 7440 Ronson Road San Diego, CA 92111 Attn: C. Brewster	1
Boeing Company, ASG, The Systems Instrumentation and Telemetry Seattle, WA 98124 Attn: Org. 2-5180 MH 8H-07 (V. A. Jennings)	1	Jet Propulsion Laboratory 4800 Oak Grove Drive (156-142) Pasadena, CA 91103 Attn: R. Piereson	1
Data Control Systems, Inc. Commerce Drive Danbury, CT 06810 Attn: M. Pizzuti D. A. Zeller	1 1	Martin-Marietta Corporation P.O. Box 179 Denver, CO 80201 Attn: MS 8200 (C. M. Kortman) (S. Hurst)	1 1
Data Control Systems, Inc. East Liberty Street Danbury, CT 06810 Attn: T. Castellano	1	McDonnell-Douglas Astronautics 5301 Bolsa Avenue Huntington Beach, CA 92647 Attn: A3-833-BBSO (D. R. Andelin) A3-250-AG30 (R. M. Frahm)	1 1
		Microcom 1115 Mearns Road Warminster, PA 18974 Attn: C. Rosen T. Grady	1 1

EXTERNAL	Copies	EXTERNAL	Copies
Monitor Systems 401 Commerce Drive Fort Washington, PA 19034 Attn: D. Mahoney	1		
Sandia Corporation Box 5800 Albuquerque, NM 87115 Attn: Division 9421 (C. S. Johnson)	1		
Teledyne Telemetry Company 1901 South Bundy Drive Los Angeles, CA 90025 Attn: H. F. Pruss	1		
University of Michigan Computer, Information and Control Engineering East Engineering, 1520 Ann Arbor, MI 48104 Attn: L. L. Rauch, PhD	1		
University of Southern California Olin Hall, University Park Los Angeles, CA 90007 Attn: Dr. W. C. Lindsey	1		
Mr. E. J. Baghdady 21 Overlook Drive Weston, MA 02193	1		
Mr. L. W. Gardenhire 906 Whitmire Drive Melbourne, FL 32935	1		
Mr. E. H. Straehley Consulting Services 1631 Platevna Road Santa Barbara, CA 93103	1		

INTERNAL	Copies	INTERNAL	Copies
Technical Director		Measurement Systems	
Code 0002		Development Division	
W. L. Miller	1	Code 3140	
		T. R. Carr	1
Project Management Group		Code 3142	
Code 0100		R. W. Lytle	1
LT COL C. L. Phillips	1	C. G. Ashley	1
Code 0150		J. Anderson	1
M. H. Cain	1	Code 3143	
		M. A. Bondelid	1
Systems Evaluation Directorate		Code 3145	
Code 1001		Z. H. Blankers	1
CAPT D. D. Buck	1		
Code 1002		Control Systems Development	
R. S. Nelson	1	Division	
		Code 3150	
Weapons Systems Test		J. R. Scott	1
Department		Code 3151	
Code 1142		A. H. Weishaar	1
C. N. Gorevin	1	J. L. Weblemoe	1
		Code 3153	
RF Weapons Systems Division		D. E. Ogden	1
Code 1262		Code 3154	
D. H. Barthuli	1	P. M. Newton	1
		C. E. Ohlen	1
Weapons Evaluation Department			
Code 1300		System Development Support	
Dr. M. A. Garcia	1	Division	
		Code 3160	
Fleet Weapons Engineering		E. F. Mutz	1
Directorate		Code 3161	
Code 2001		R. L. Nifong	1
CAPT D. DeWitt	1	Code 3163	
		F. L. Allard	1
Range Directorate			
Code 3001		Data Collection Division	
CAPT G. M. Dempsey	1	Code 3410	
		R. P. Carpenter	1
Capabilities Development		Code 3411	
Department		R. J. Roanhaus	1
Code 3100		R. H. Wymore	1
W. C. Christensen	1	J. T. Dickman	1
Code 3101		W. T. Norton	1
J. A. Means	1	Code 3412	
		F. D. Leiblein	1
Development Management			
Division		Data Control Division	
Code 3120		Code 3440	
H. J. Crawford	1	W. F. Tolman	1

INTERNAL	Copies	INTERNAL	Copies
Engineering Applications Directorate		Instrumentation Engineering Division	
Code 4001		Code 4330	
N. F. Rohn	1	R. P. Tegt	1
Code 4002		Code 4331	
LCDR R. P. Evans	1	M. A. Beckman	1
		T. P. Waddell	1
Equipment Support Division		Instrumentation Support Division	
Code 4131-1		Code 4340	
R. W. Kenny	1	J. D. Martin	1
Technical Publications Division		Code 4341	
Code 4250-1		E. R. Sandy	1
M. F. Hayes	10	G. J. Harbold	1
Code 4251		N. R. Dragoo	1
D. S. Walker	1	D. J. DeJong	1
Code 4253-3		Office of Patent Counsel	
Technical Reports Library	2	Code PC	
Instrumentation Department		Dr. J. M. St. Amand	1
Code 4300			
V. E. Orris	1		
Instrumentation Development Division			
Code 4320			
K. L. Berns	1		
Code 4321			
F. R. Hartzler	1		
D. R. Hust	1		
D. H. Rilling	1		
M. V. Wechsler	1		
Code 4322			
E. R. Hill	1		
D. R. Knight	1		
D. A. King	1		
D. L. Laubacher	1		
Code 4323			
E. L. Law	50		
B. E. Bishop	1		
E. T. Kimball	1		
C. M. Kaloi	1		

THIS REPORT HAS BEEN DELIMITED
AND CLEARED FOR PUBLIC RELEASE
UNDER DOD DIRECTIVE 5200.20 AND
NO RESTRICTIONS ARE IMPOSED UPON
ITS USE AND DISCLOSURE.

DISTRIBUTION STATEMENT A

APPROVED FOR PUBLIC RELEASE;
DISTRIBUTION UNLIMITED.