

UNCLASSIFIED

AD NUMBER

ADB012378

LIMITATION CHANGES

TO:

Approved for public release; distribution is unlimited.

FROM:

Distribution authorized to U.S. Gov't. agencies only; Test and Evaluation; 09 MAR 1976. Other requests shall be referred to Picatinny Arsenal, Dover, NJ.

AUTHORITY

USAARDEC ltr 23 Jun 1989

THIS PAGE IS UNCLASSIFIED

2 B.S.

ADB012378

COPY NO. 26

TECHNICAL REPORT 4842

DYNAMIC ANALYSIS OF THE SAFING AND ARMING SYSTEM FOR PD FUZE M572E2



EDWIN B. ENTIN

MARCH 1976

DDC
RECEIVED
JUL 29 1976
SARPA-TSS

AD No. _____
DDC FILE COPY

Distribution limited to U. S. Government agencies only (test and evaluation; 9 March 1976). Other requests for this document must be referred to Picatinny Arsenal, ATTN: SARPA-TSS, Dover, NJ.

PICATINNY ARSENAL
DOVER, NEW JERSEY

The findings in this report are not to be construed as an official Department of the Army position.

DISPOSITION

Destroy this report when no longer needed. Do not return to the originator.

UNCLASSIFIED

SECURITY CLASSIFICATION OF THIS PAGE (When Data Entered)

REPORT DOCUMENTATION PAGE		READ INSTRUCTIONS BEFORE COMPLETING FORM
1. REPORT NUMBER Technical Report 4842	2. GOVT ACCESSION NO.	3. RECIPIENT'S CATALOG NUMBER
4. TITLE (and Subtitle) DYNAMIC ANALYSIS OF THE SAFING AND ARMING SYSTEM FOR PD FUZE M572E2		5. TYPE OF REPORT & PERIOD COVERED
7. AUTHOR(s) Edwin B. Entin		5. PERFORMING ORG. REPORT NUMBER
8. PERFORMING ORGANIZATION NAME AND ADDRESS Ammunition Development & Engineering Directorate Picatinny Arsenal, Dover, NJ		8. CONTRACT OR GRANT NUMBER(s) AMCMS Code 4110.16.4737.7
11. CONTROLLING OFFICE NAME AND ADDRESS PA-TR-4842	12. REPORT DATE March 1976	10. PROGRAM ELEMENT, PROJECT, TASK AREA & WORK UNIT NUMBERS DA Project No. GG9-7029
14. MONITORING AGENCY NAME & ADDRESS (if different from Controlling Office) 12/9Lp.	13. NUMBER OF PAGES 94	15. SECURITY CLASS. (of this report) Unclassified
16. DISTRIBUTION STATEMENT (of this Report) Distribution limited to U.S. Government agencies only (test and evaluation; 9 March 1976). Other requests for this document must be referred to Picatinny Arsenal, ATTN: SARPA-TS-S, Dover, NJ.		
17. DISTRIBUTION STATEMENT (of the abstract entered in Block 20, if different from Report)		
18. SUPPLEMENTARY NOTES		
19. KEY WORDS (Continue on reverse side if necessary and identify by block number) Artillery fuzes Dynamic response analysis Impulse loading PD fuze M572E2 Supplementary charge analysis Balloting Setback-pin response Lumped parameter model Damping Auto-delay system response Failure mode analysis		
20. ABSTRACT (Continue on reverse side if necessary and identify by block number) This report covers the investigation of those factors which caused the duds experienced in low-zone firings of 155 mm and 8-Inch howltzers during the service tests of PD fuze M572E2 in July 1972. In addition to diagnostic testing, the investigation included analytical programs by AVCO Systems Division and Honeywell, Inc. The AVCO program was a lumped- parameter (equivalent spring-mass systems) analysis of both the complete 8-inch		

DD FORM 1 JAN 73 1473 EDITION OF 1 NOV 65 IS OBSOLETE

UNCLASSIFIED
SECURITY CLASSIFICATION OF THIS PAGE (When Data Entered)

282 900

(over)

43

UNCLASSIFIED

SECURITY CLASSIFICATION OF THIS PAGE(When Data Entered)

↓ 20. Abstract (Continued)

↓ round and pertinent fuze components for axial component motion. The Honeywell program was an investigation of the dynamics of various setback-pin designs during the firing cycle.

↑
Evaluation of the test results ^{and} and analytical programs indicated that the problem was due to the SGA setback pin re-engaging the rotor, thus preventing arming. A number of design changes, made to delay the return of the setback pin and dampen its rebounding, were successfully tested. Most significantly, the setback pin was redesigned and the center of gravity lowered; both the length and diameter of the cavity were increased and the ramp angle was made more abrupt, and flat, energy-absorbing material was put into the base of the setback-pin cavity.

UNCLASSIFIED

SECURITY CLASSIFICATION OF THIS PAGE(When Data Entered)

The citation in this report of the names of commercial firms or commercially available products or services does not constitute official endorsement or approval of such commercial firms, products, or services by the U.S. Government.

FORWARD BY		
DTIC	White Section	<input type="checkbox"/>
DDI	Staff Section	<input checked="" type="checkbox"/>
UNCLASSIFIED		<input type="checkbox"/>
JUSTIFICATION		
BY		
DISTRIBUTION/AVAILABILITY CODES		
Dist. AVAIL. and/or SPECIAL		
B		

ACKNOWLEDGMENTS

For their contributions to this project, the author is grateful to the following personnel of the Fuze Engineering Branch, Picatinny Arsenal: Elber W. Stearns, Jr., William Pellet, Roy Noble, Walter Erck, Patrick DeBari, Joseph Buonincontri, and Stephan Kosonocky. The author is also grateful to the personnel of Honeywell, Inc., and AVCO Systems Division who contributed to the analytical portions of this project. In addition, the author is especially grateful to John Domen of the Product Assurance Directorate, Picatinny Arsenal, for his valuable contributions to this project and his aid in the preparation of this report.

TABLE OF CONTENTS

	<u>Page No.</u>
Summary	1
Introduction	2
History of the M572E2 Program	2
Fuze Characteristics	2
History of the Setback-Pin Problem	6
Discussion	7
Problem Analysis and Proposed Solution	7
Confirmation of Solution	12
Investigation	12
Analytical Programs	18
Structural Dynamic Response Analysis	18
Dynamics of Setback Pin During Firing	36
Supporting Programs	41
Analysis of Results	42
Conclusions	43
Recommendations	44
Appendixes	
A 1972 Equipment Performance Reports (EPR'S) for Fuze M572E2	47
B Summary of 1972 Tests (ED, ET, & ST) of Fuze M572E2	53
C 1972 Diagnostic Test Reports for Fuze M572E2	63

Figures

1	Cross section of fuze M572E2	4
2	Functional diagram of fuze M572E2	5
3	Safety features in S&A module	9
4	Setback pin and cavity area	10
5	Relocated rotor gear stake	11
6	Setback-pin functioning sequence	15
7	Setback-pin analysis	16
8	Failure diagram	17
9	Lumped parameter breakdown of 8-inch projectile	20
10	Lumped parameter model of shell	21
11A	Lumped parameter system for fuze M572E2	22
11B	Lumped parameter system for fuze M572E2 (cont)	23
12	Supplemental charge model	26
13	Setback-pin model	29
14	Setback-pin response $\zeta = 25$ percent	30
15	Setback-pin response $\zeta = 50$ percent	31
16	Setback-pin response $\zeta = 100$ percent	32
17	Setback-pin response $\zeta = 1,000$ percent	33
18	Setback-pin response $\zeta = 25$ percent, $k \rightarrow 20$ g's	35

19	Low G setback-pin response to 8-inch zone 1 firing	38
20	Parabolic-type bounce for tungsten setback-pin design (PA-34)	39
	Distribution List	87

SUMMARY

This program was undertaken to identify and correct those factors which caused duds during the M572E2 fuze service tests in low-zone (zones 1 and 2) firings of 155 mm and 8-inch howitzers. The tests were conducted at Fort Sill in July 1972. The M572E2 fuze was developed to replace the M557 and M572 fuzes, and offers many advantages over the older models. It had previously passed ED testing (in 1971) before the dud problem was encountered.

In addition to diagnostic testing, the investigation included analytical programs by AVCO Systems Division and Honeywell, Inc. The AVCO program was a lumped-parameter (equivalent spring-mass systems) analysis of both the complete 8-inch round and pertinent fuze components for axial component motion. The Honeywell program was an investigation of the dynamics of various setback pin designs during the firing cycle. Evaluation of the test results and analytical programs indicated that the problem was due to the safing and arming (S and A) setback pin re-engaging the rotor, thus preventing arming. A number of design changes were made to delay the return of the setback pin and dampen its rebounding. The most significant of these changes were:

1. The setback pin was redesigned and the center of gravity lowered
2. Both the length and diameter of the cavity were increased and the ramp angle was made more abrupt, and
3. A flat, energy-absorbing material was put into the base of the setback-pin cavity.

Fuzes with these design changes incorporated were then successfully tested and ET/ST testing was resumed in August 1973.

After the above changes were made, three fuze problems were encountered during ET/ST testing in 1973. Subsequent tests and analyses, however, proved conclusively that all three problems were caused by the auto delay rather than the setback pin. Consequently, the auto delay has been replaced by the M1 delay plunger and DT/OT testing (formerly ET/ST testing) was resumed in May 1974.

INTRODUCTION

History of the M572E2 Program

In 1962, ballistic tests proved that PD fuze M557 was not rugged enough to withstand the interior ballistic environment of the 175 mm gun. As a result, PD fuze M572 was created by filling the ogive of the M557 fuze with 2.5 ounces of epoxy. The cured epoxy resin supported the flash tube and ogive in the M572, preventing them from separating in the gun or in flight. An increase in unit cost and weight was the price paid for this temporary fix.

Field experience in Vietnam established the urgent need for a number of product improvements to both the M557 and the M572 fuzes. This need resulted in the initiation of the M572E2 Product Improvement Program. The New Materiel Review Board, in NM-70, dated 26 March 1970, defined the design objectives as follows:

1. Provide a rugged fuze capable of withstanding the ballistics of the new, increased-range gun systems and of reducing proliferation.
2. Provide decreased sensitivity to rain and foliage.
3. Provide a sealed fuze for long storage reliability.
4. Provide a 1.5-pound fuze to comply with new ballistic-match requirements.
5. Provide a less expensive fuze.
6. Provide greater uniformity of product through automated production and quality control.
7. Design to conform with DoD-directed copper savings program and cost reduction policies.

Fuze Characteristics

The M572E2 is a point-detonating fuze used in 105 mm, 155 mm, and 8-inch howitzers, 175 mm guns, and 4.2-inch mortars.

The major components of the fuze (Fig 1) are listed below. A functional diagram is shown in Figure 2.

1. A one-piece, impact extruded, aluminum body (for structural ruggedness) with a standard 2-inch thread for assembly to the projectile.
2. A cross-bar holder assembly in the nose section. The cross bars act as spokes which break up raindrops and foliage and reduce fuze sensitivity to an acceptable level without affecting sensitivity to impact on the ground or with other proper targets.
3. A firing pin and detonator assembly for sensitive impact functioning.
4. A setting sleeve assembly to permit selection and operation in the delay or superquick modes.
5. An M1 delay plunger with a nominal .050-second delay which provides for bunker penetration and also acts as a backup for the superquick setting (i.e., graze). (During both 1972 and 1973 ET/ST testing the fuze contained an auto delay which has now been replaced by the M1 delay plunger due to problems encountered during testing.)
6. An S&A module with both setback and spln locks, thus fulfilling the requirement for a dual safing system, as well as providing the required delay arming.
7. A booster pellet for propagation of the round.

The M572E2 fuze design provides the following essential features:

1. Increased capability:
 - a. Structural integrity - current and future weapons
 - b. Single PD fuze
 - c. Rain insensitivity and jungle canopy penetration
 - d. Sealing for long-term storage reliability
 - e. Improved hard target penetration
 - f. A 1.5-pound weight for ballistic match

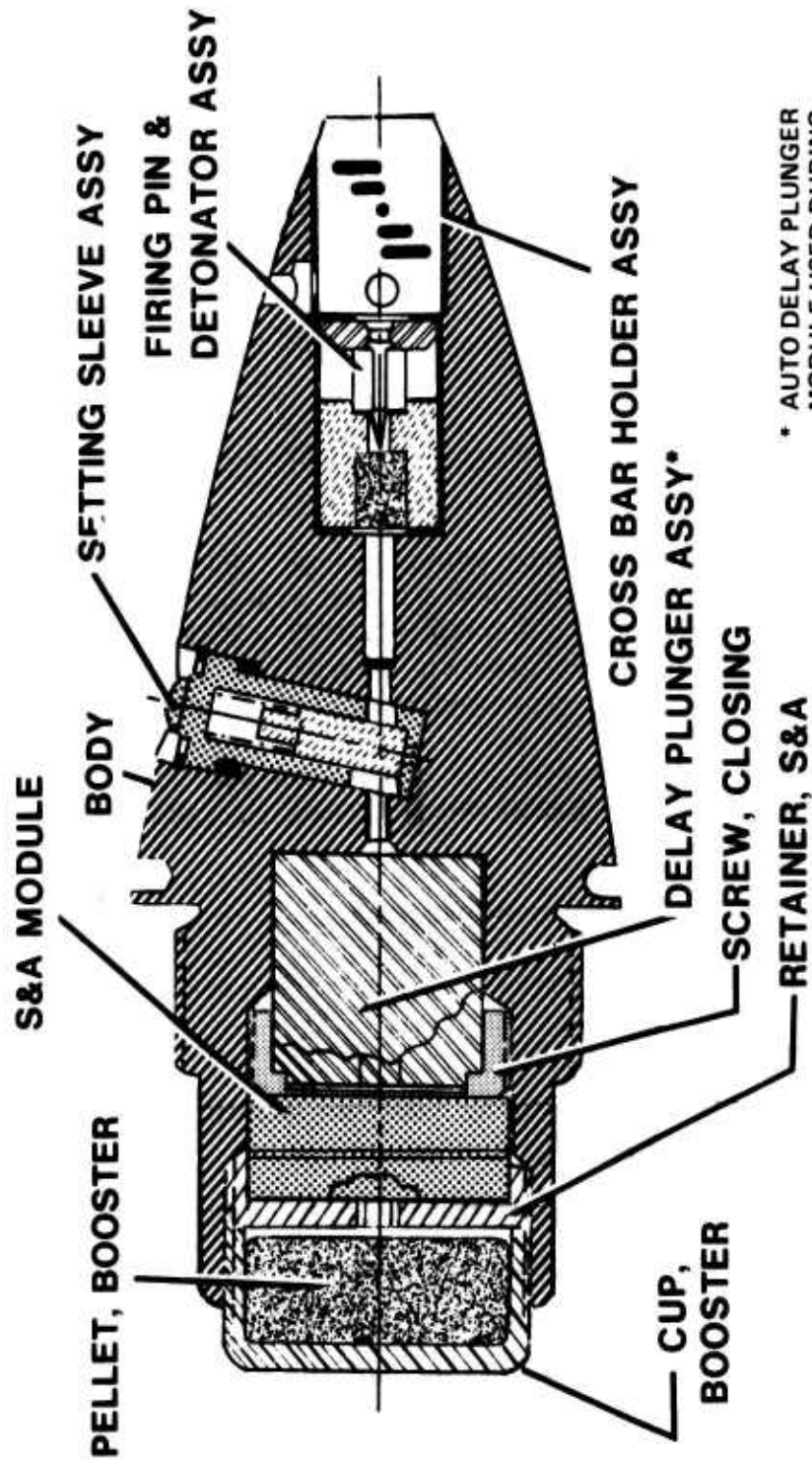

* AUTO DELAY PLUNGER
MODULE USED DURING
1972 & 1973 ET/ST
TESTING

Fig 1 Cross section of fuze M572E2

1972 & 1973 ET/ST CONFIGURATION

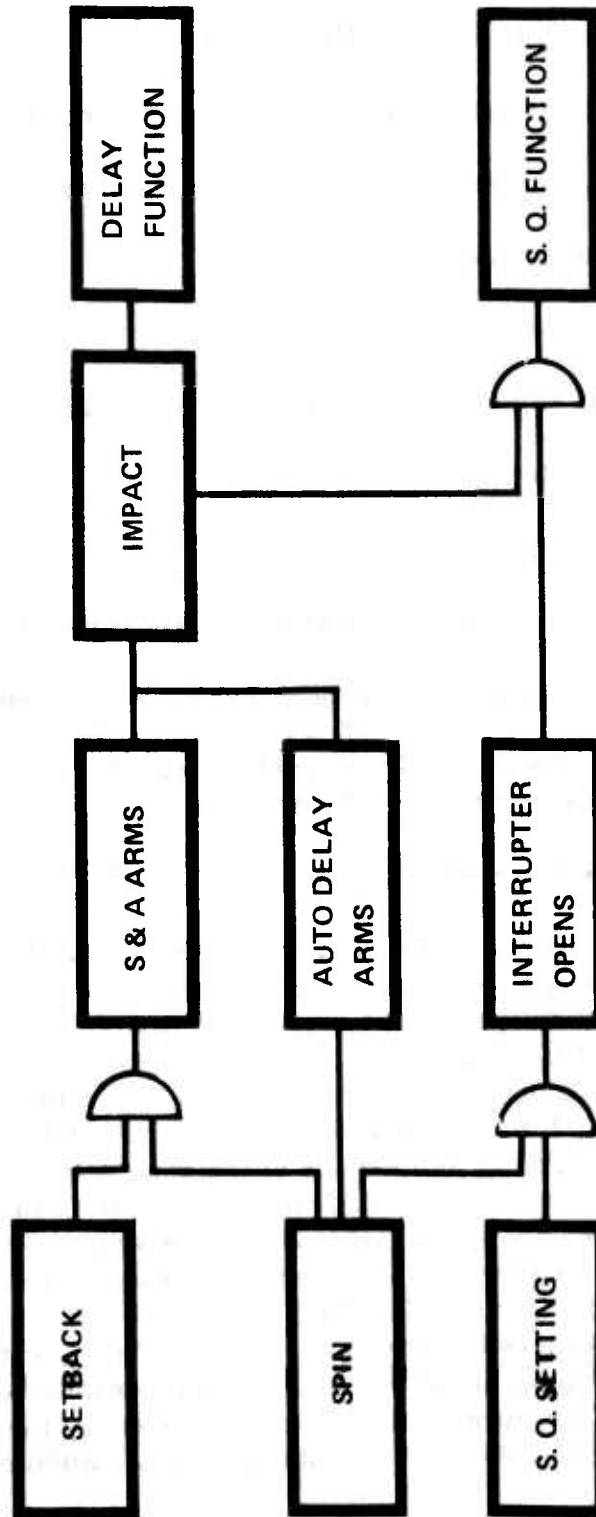

Fig 2 Functional diagram of fuze M572E2

2. Added safety:
 - a. Dual safety - MIL-STD-1316
 - b. Structural integrity - current and future weapons
 - c. No early function in heavy rain or jungle canopy
3. Cost savings:
 - a. Less expensive
 - b. Waterproofing reduces costly renovation
 - c. Minimizes use of brass
4. Producibility:
 - a. Designed for automated assembly and inspection
 - b. Expansion of production base in minimum time
 - c. Flexibility in production; capable of being produced on modular or complete fuze (less booster) basis.

History of the Setback-Pin Problem

The first evidence that a problem might exist with the setback pin of the M572E2 fuze actually occurred during ED testing. The problem occurred infrequently, and the overall results of the tests were considered to be highly successful. It was not recognized at the time that a setback-pin problem existed, because the true magnitude of the problem was obscured by lubrication difficulties. A total of 646 rounds were fired during ED testing in a variety of weapons selected to provide extreme launch environments. Three duds occurred in the zone 1 mode of the 155 mm howitzer, a low spin, low-velocity weapon. All fuzes functioned in the zone 1 mode of the 8-inch howitzer, which is also a low spin, low-velocity weapon. During ST testing at Fort Sill, however, roughly 20% duds were encountered in the zone 1 mode of the 155 mm and 8-inch weapons. Additional tests showed that the problem also occurred in the zone 2 mode. Therefore, testing was suspended by the U.S. Army Field Artillery Board on July 31, 1972, and an investigation of the problem was

initiated. Copies of the equipment performance reports appear in Appendix A; the ED, ET, and ST tests are summarized in Appendix B.

Two secondary problems also occurred during 1972 ET/ST testing. One problem was that a 2.6% dud rate occurred in zone 7 firings of the 105 mm progressive-twist weapon. This problem was subsequently attributed to prerelease of the auto delay. The other problem was that reverse functions (i.e., delayed functioning of rounds set on superquick) occurred in low angle, low-velocity firings of the 8-inch howitzer on hard soil. This problem was attributed to the PD module being pinched off. These two secondary problems were corrected prior to resumption of ET/ST in August 1973. They will not be discussed in this report, however, since it is being written to provide insight into the "lessons learned" from the S&A setback-pin investigation.

During the 1973 ET/ST testing, the auto delay prerelease problem re-occurred in a different weapon (155 mm M109A1 howitzer) at zones 2 and 3. Because of this problem and two other problems also associated with the auto delay, it has been replaced by the M1 delay plunger in the current design. The two other problems associated with the auto delay were occasional high air-burst functions in high velocity, low-elevation firings into ground targets with the fuze set on delay, and less delay reliability than that of the standard M557 fuze.

DISCUSSION

Problem Analysis and Proposed Solution

Analysis of the problem (eliminating duds and improving reliability of low-zone firings in the 155 mm and 8-inch howitzers) indicated that the solution required:

1. A design which prevented or slowed the return of the setback pin after setback, so as to prevent the pin from interfering with the motion and arming of the rotor.
2. Elimination of any physical interruption of the proper motion of the setback pin or rotor.

Several modifications within the S&A module were made to the design and configuration of the setback pin, cavity, spring, and rotor. The specific changes are discussed below.

1. A setback pin made from a heavier material (tungsten) and featuring a larger base diameter with a corresponding lower center of gravity, was substituted for the original steel setback pin. The heavier material permits the use of a more readily producible setback spring. The center of gravity was lowered to increase the centrifugal holding force of the setback pin toward the sidewall and avoid rapid tilting motion of the pin whenever the shell might experience sudden lateral displacements down bore.

2. The displacement travel distance (stroke) of the setback pin within the setback-pin cavity was increased from 0.078 inch to 0.236 inch to delay the return of the setback pin, and the ramp angle of the cavity made more abrupt (from 40° to 55°) to assist in stopping pin motion along the wall and/or ramp.

3. The setback-pin length was decreased from 0.158 inch to 0.140 inch to delay the return of the setback pin.

4. The setback-pin spring's G level was reduced from 33 G's to 20 G's and the spring was made longer and larger in both wire diameter and overall diameter. These changes reduced the spring return force on the setback pin and also made the spring compatible with the lengthened cavity.

5. The aluminum-dimple configuration retainer plate at the cavity base was removed and replaced by a soft-aluminum flat disc to further dampen any axial bounce of the setback pin.

6. The hole and staking for the rivet pin, which holds the rotor gear to the rotor, were relocated inboard to prevent interference of the rotor and setback pin.

7. An illustration of the S&A module, indicating the safety features, is shown in Figure 3. The final changes made to the setback pin and cavity area of the S&A, and to relocate the rotor gear stake are shown in Figures 4 and 5, respectively.

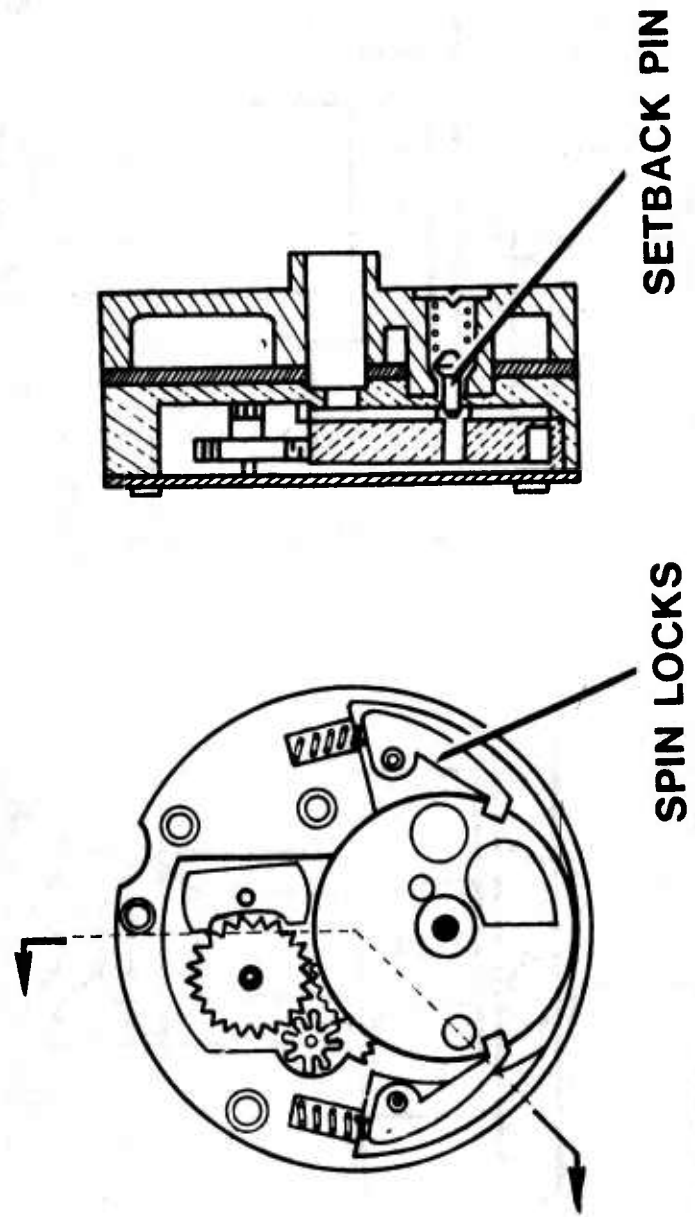
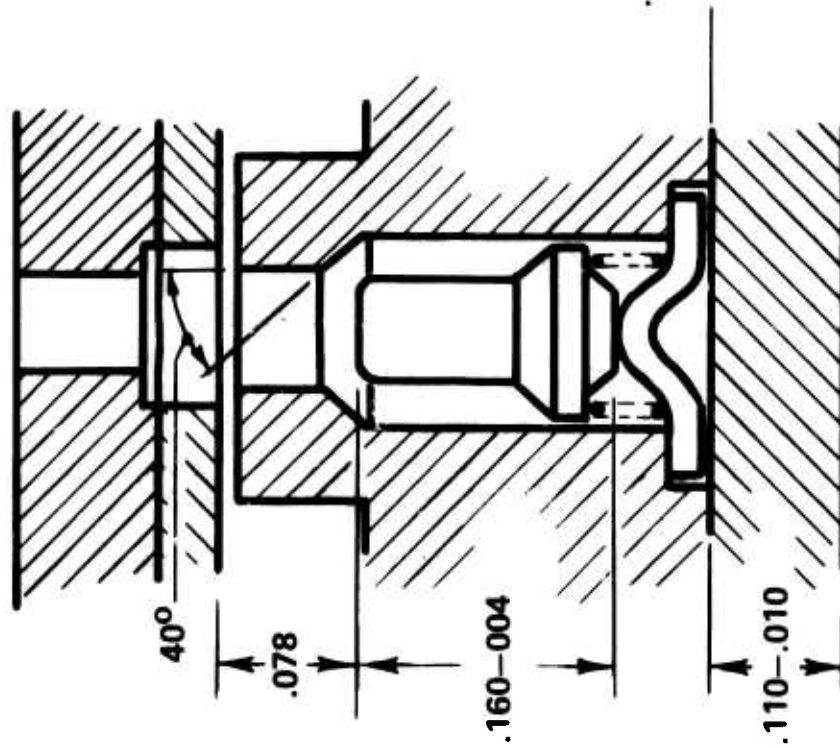

Fig 3 Safety features in S&A module

1972 ET/ST DESIGN
(.078 DISPLACEMENT)
33 G SETBACK SPRING
STEEL SETBACK PIN



1973 ET/ST DESIGN
(.236 DISPLACEMENT)
20 G SETBACK SPRING
TUNGSTEN SETBACK PIN

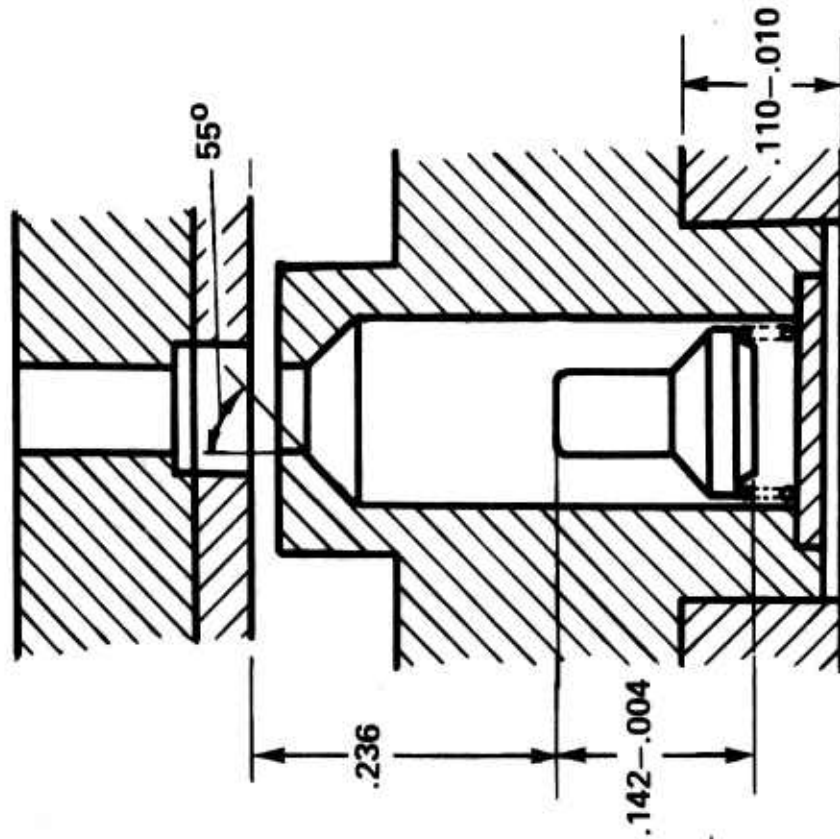
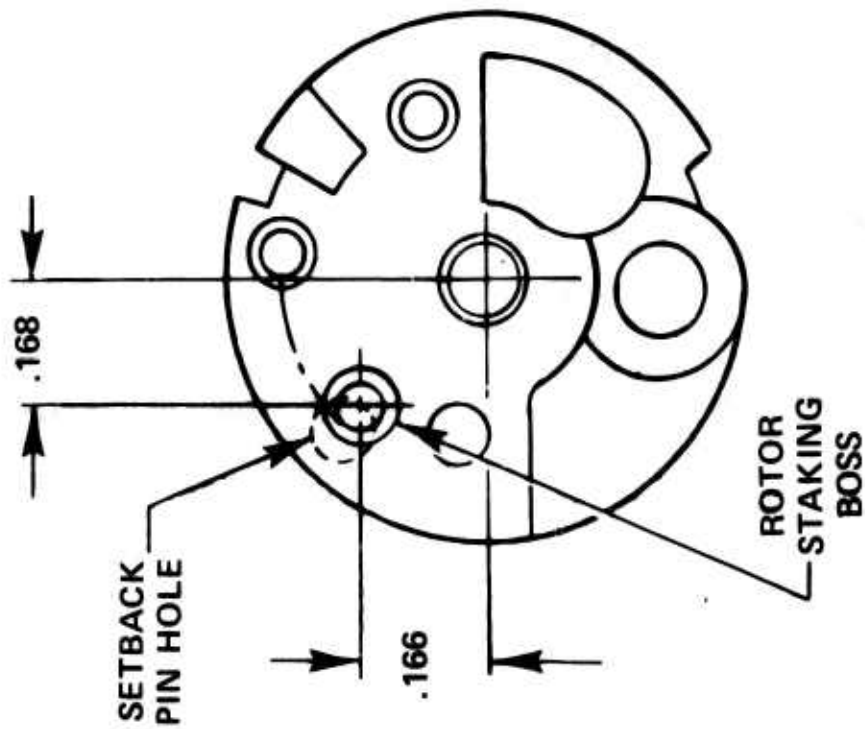

Fig 4 Setback pin and cavity area

1972 ET/ST ROTOR BODY



1973 ET/ST ROTOR BODY

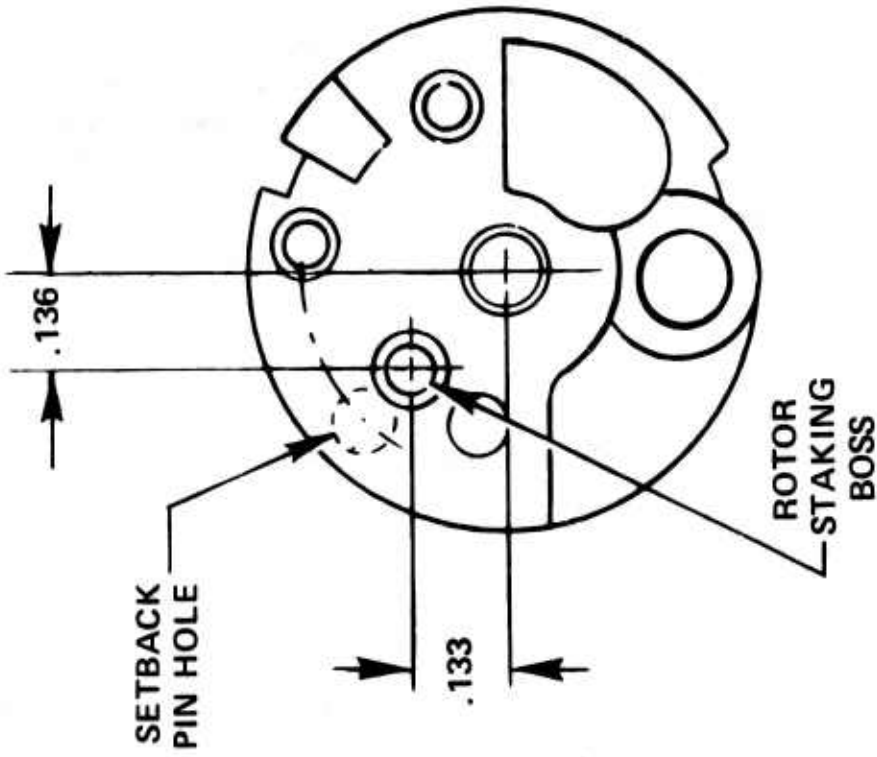

Fig 5 Relocated rotor gear stake

Confirmation of Solution

A total of 192 fuzes (incorporating the changes listed in the Problem Analysis and Proposed Solution section of this report) were tested under a variety of conditions. There were no duds. This was considered adequate justification for resuming ET/ST testing and repeating the phases of the tests in which the failures occurred. All tests were conducted at Yuma Proving Ground using HE projectiles and ground impact. A summary of the information from the tests is shown below:

Test summary

<u>Date</u> (1973)	<u>Lot</u> <u>number</u>	<u>Weapon/</u> <u>zone</u>	<u>Mode</u>	<u>Temp</u>	<u>No.</u> <u>fired</u>	<u>No.</u> <u>functioned</u>
Apr 3-13	PA-34	8"/zone 1	SQ	Amb	48	48
		105 mm/ zone 7	Del	Amb	24	24
		4.2"/ Incr 10	SQ	Amb	24	24
Apr 24	PA-41	8"/zone 1	SQ	Amb	32	32
		8"/zone 1	SQ	+145°	32	32
		8"/zone 1	SQ	-50°F	<u>32</u>	<u>32</u>
Total					192	192

Investigation

The investigation of the M572E2 fuze dud problem due to S&A failures consisted of the following four phases: preliminary analysis, diagnostic tests, analytical programs, and supporting programs. Each of these phases is discussed in detail in the subsequent sections of this report.

The analytical programs consisted of two separate efforts, one by AVCO Systems Division and one by Honeywell, Inc. The AVCO program was a structural dynamic-response analysis employing coupled, damped spring-mass, lumped-parameter systems. The Honeywell program was an investigation of the dynamics of various setback pins during firing.

The diagnostic tests, performed concurrently with the analytical programs, made use of the output from these programs. These tests involved a series of fuze modifications which resulted in a number of design changes. The final design changes were then successfully tested at Yuma Proving Ground as identified in the section entitled "Confirmation of Solution."

Preliminary Analysis

A preliminary analysis of all the factors within the fuze and/or fuze environment which might contribute to S&A failures (viewed prior to the diagnostic testing) produced the following possible causes:

1. At low spin, the weak centrifugal force on the setback pin might allow the pin to return too soon and prevent the rotor from arming.
2. Failure of the rotor to drive through the gear train.
3. Failure of the spin detent to retract or possibly re-engage the rotor.
4. Hang-up of the rotor due to possible interference between the rotor gear stake and the setback pin.
5. Structural failure of the rotor lock pin on impact, permitting the rotor to move away from the armed position.

A review of these failure possibilities and other information led to the conclusion that the failures were most likely related to the function of the setback pin. As a result, the following analysis of the setback pin's function was made in August 1972:

The M572E2 fuze setback pin's function is to lock the rotor in its safe, out-of-line position until the firing environment is sensed. With

the onset of setback, the pin moves aft and releases the rotor. With side forces arising from balloting or tube vibrations neglected for the moment, the pin, after several initial axial bounces, is expected to remain aft throughout most of the setback curve. As spin increases (Fig 6), the pin may pivot on the rather pointed top of the aluminum dimpled disc toward the cavity sidewall. When the muzzle is cleared, the spring force is insufficient to slide the pin forward against the retarding forces introduced by the side and ramp of the cavity, if the spin is high enough. Under most firing conditions, the setback pin apparently behaves as expected and the rotor is permanently released. The duds, though, were limited to low-zone firings of the 155 mm and 8-inch howitzers.

The dynamic analysis showed that for low-zone firings after the shell exited the muzzle, a degree of marginality was being reached in the design considered if the friction coefficient between pin and cavity began reaching a low value of about 0.15. The model considered pin motion up along the cavity wall and ramp under the influence of spring and spin forces. With the initial conditions of the pin in the bottomed, tilted position upon muzzle exit, the pin ordinarily did not reinsert; if it did, it occurred in about seven milliseconds after muzzle exit. Figure 7 shows this demarcation. Axial tolerances can allow the pin some "run up" distance along the wall before the ramp is engaged. Any introduction of appreciable side forces just at muzzle exit can produce temporary separation of the pin from the sidewall, resulting in an "effective" lowered friction coefficient.

Design changes inferred from the August 1972 model of the pin moving under the influence of centrifugal and continuous friction force from the wall and ramp did not prevent the pin from reinserting into the rotor in ballistic tests. It was necessary to change the design based on the further consideration that intermittent strong side forces from balloting and/or tube vibration at the time of muzzle exit could be operating. Such forces involved rapid lateral translation of the entire shell.

The failure diagram used in the preliminary analysis which identified the failure causes is shown in Figure 8. The primary failure mode (setback-pin failures) applicable to the S&A failures in low-zone howitzers, addressed by this report, is enclosed by a solid line. The two secondary failure modes, not covered in this report, are enclosed by broken lines.

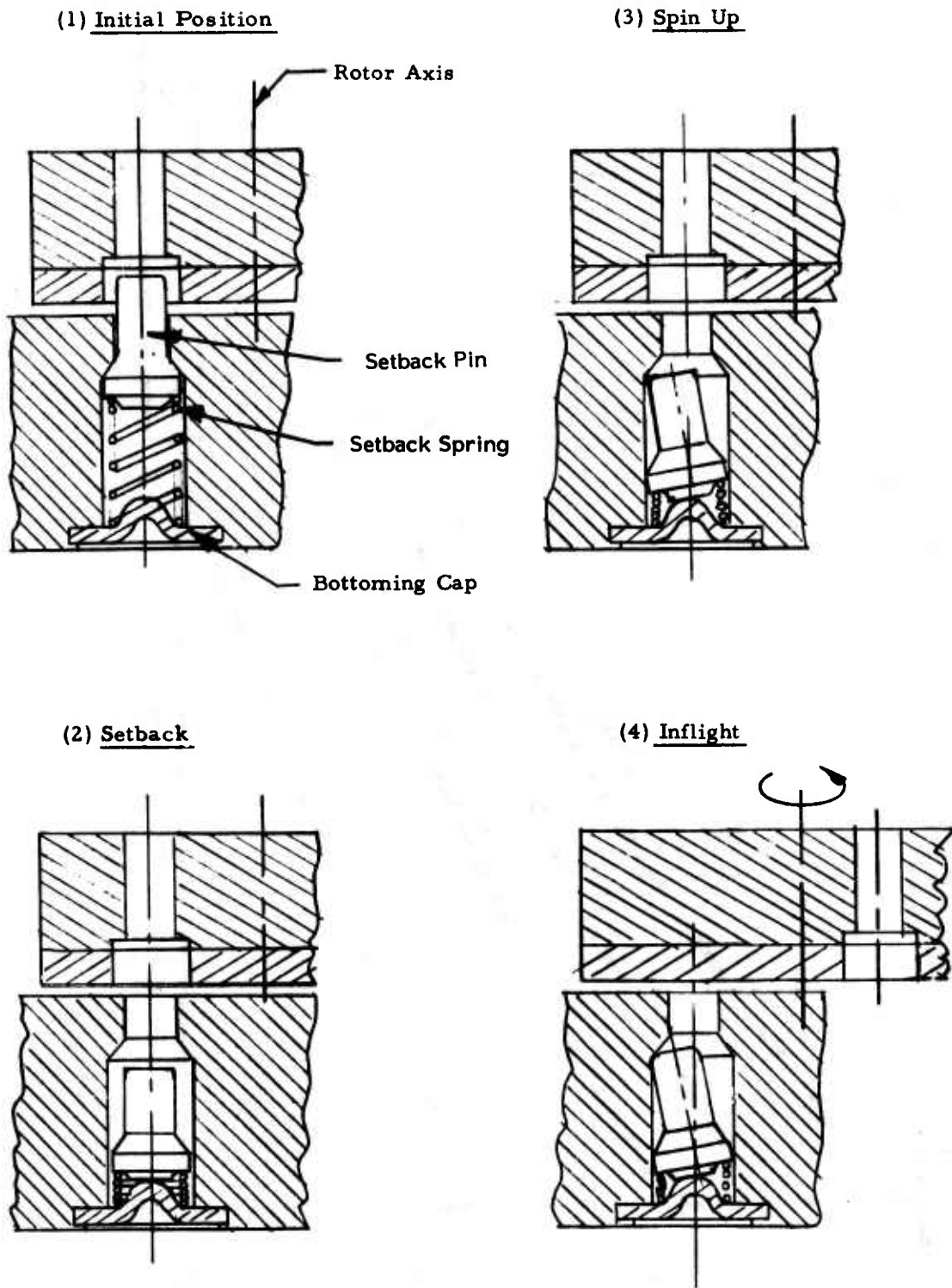

Fig 6 Setback-pin functioning sequence

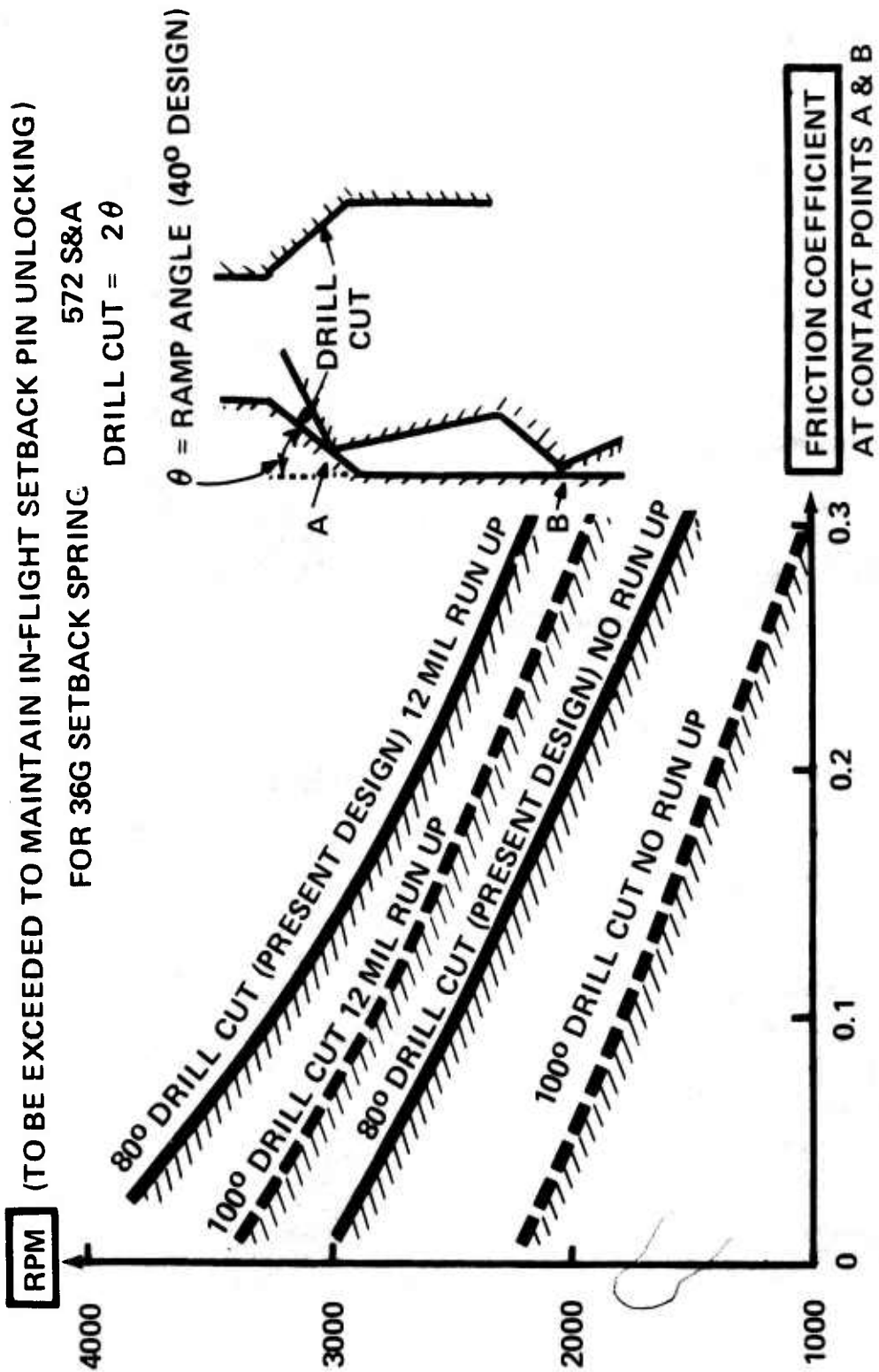

Fig 7 Setback-pin analysis

1972 & 1973 ET/ST CONFIGURATION

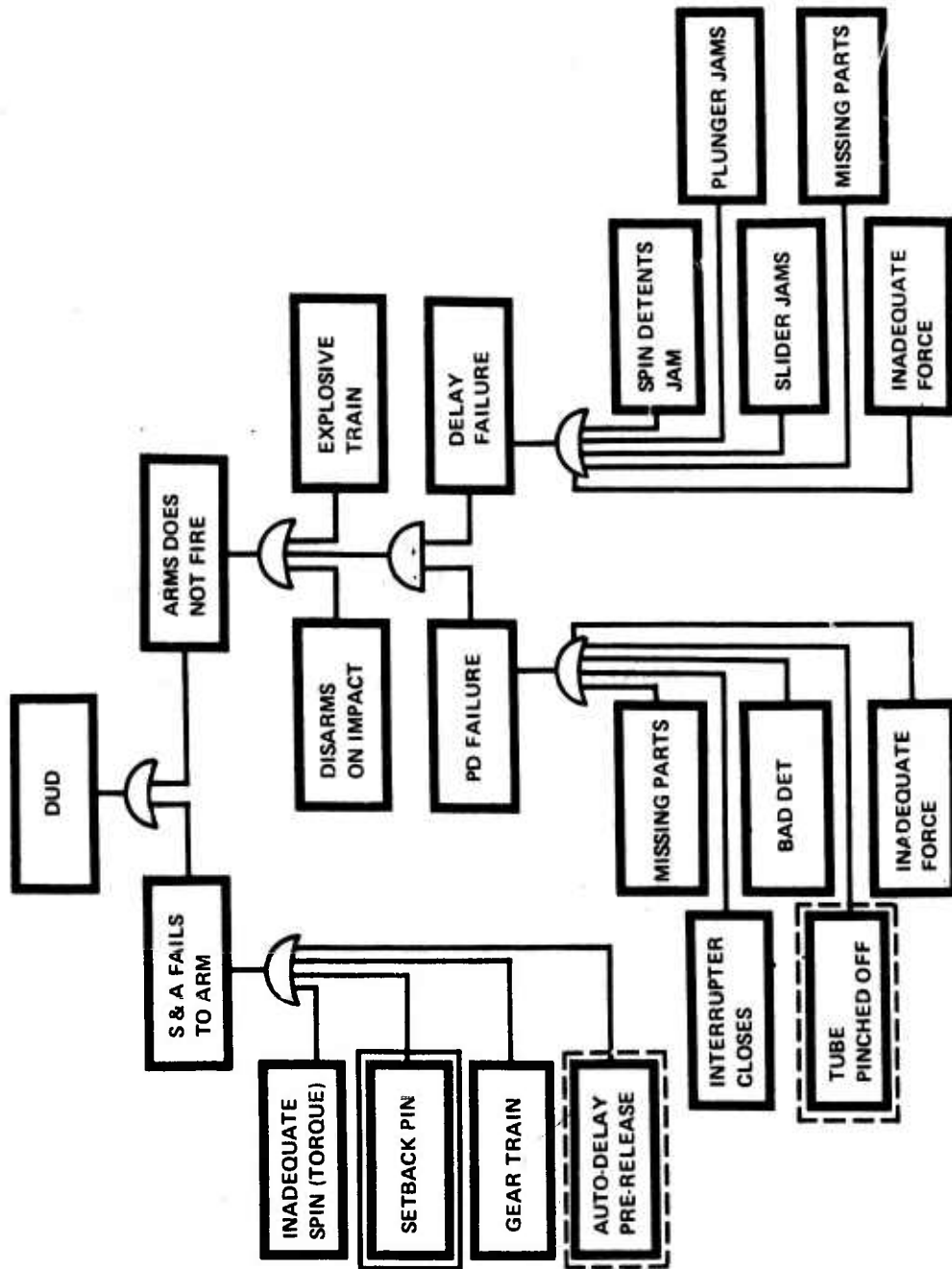

Fig 8 Failure diagram

Diagnostic Tests

The diagnostic test phase of the investigation consisted of a series of ballistic tests involving various modifications to the fuze. The results of each test were evaluated before the modifications to be used in the next test were determined. In addition, the information from the analytical programs and supporting programs (discussed later in this report) was used as an aid in determining the modifications to be tested.

The reports from the diagnostic tests are presented in chronological order in Appendix C. Unless otherwise stated, all changes and modifications made in this series of tests were made to the original 1972 ET/ST fuze design. Percentages and ratios given in the test reports are figures for proper functioning versus total firings. Unless otherwise noted, all fuzes were complete items, fully loaded, and the rounds were HE filled. It should be noted that in some instances the test reports contain information relating to the auto delay and PD-module problems rather than the S&A problem, because all three problems were investigated concurrently.

ANALYTICAL PROGRAMS

Structural Dynamic Response Analysis

In November 1972, AVCO Systems Division was informed of the M572E2 fuze dud problem due to S&A failures and was asked to conduct an analytical investigation to determine its causes. AVCO Systems Division was selected because of its previous success in modeling complex electromechanical systems and because of the similarity between the present problem and others investigated by them for Picatinny Arsenal and the US Air Force.

At that time AVCO Systems Division was under contract performing test programs and analyses relative to the determination of environments of fuze systems and related components. This work required the generation of analytical math models simulating both the flexibilities of the weapon and the events sequencing of electromechanical components under the action of applied environments.

The analytical approach taken by AVCO Systems Division to help solve the problem was a structural dynamic-response analysis. This analysis was a lumped-parameter approach which formulated the elasticity of the projectile body, filler material, and fuze structure by reducing them to many spring-mass systems. (See Figures 9, 10, and 11.)

One of the ground rules affecting AVCO's investigation was that the analysis be conducted within a three-week period. This of course, influenced the approach and assumptions made during the course of the study.

After an initial data-gathering task, the following principal efforts were made as part of the analysis:

1. The postulation of potential dynamic responses of the components to the inbore applied loading environment and the potential failure modes which could result from these responses.
2. The development of a dynamic math model representative of the 8-inch projectile and the fuze, including the required degrees-of-freedom of the fuze components.
3. Exercising the model to determine the response of the pertinent fuze components.
4. Determining the potential failure modes.
5. Modifying the math model to investigate potential solutions to the problems.
6. Recommending approaches to solutions.

Prior to the investigation into the fuze component response, it was necessary to fully describe the inbore environments applied to the 8-inch projectile which induced the failure modes. The transient resistance to motion due to the rotating band was included because of its effect upon the elastic response of the projectile. A sudden drop in resistance, as during the transition between static and dynamic resistance, could cause additional structural response and, in turn, affect fuze component responses. As it turned out, this consideration had little effect upon overall structural response or fuze functioning. Another significant potential inbore environment which was qualitatively considered during the response analysis was that caused by balloting.

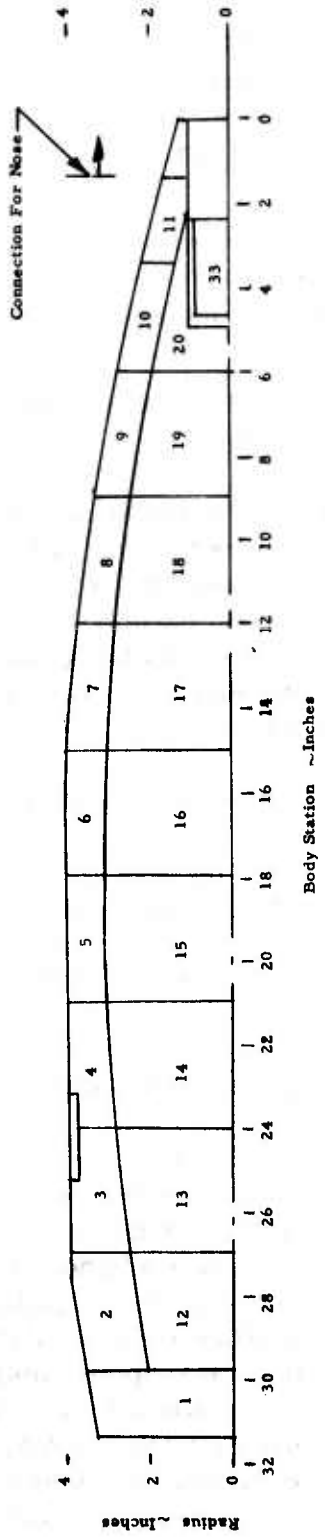

Fig 9 Lumped parameter breakdown of 8-inch projectile

LUMPED PARAMETER MODEL OF SHELL

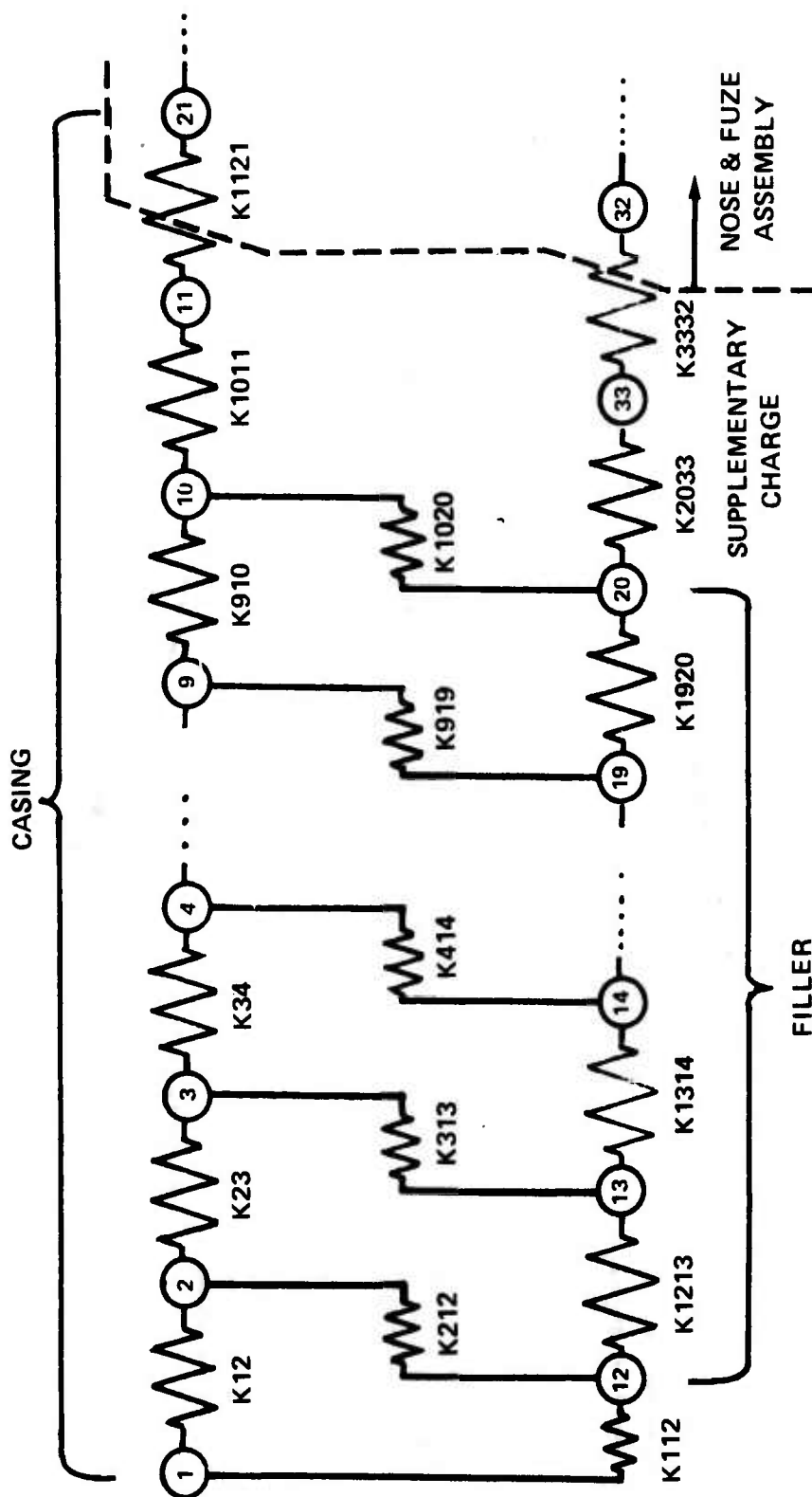

Fig 10 Lumped parameter model of shell

LUMPED PARAMETER SYSTEM M572E2 PD FUZE

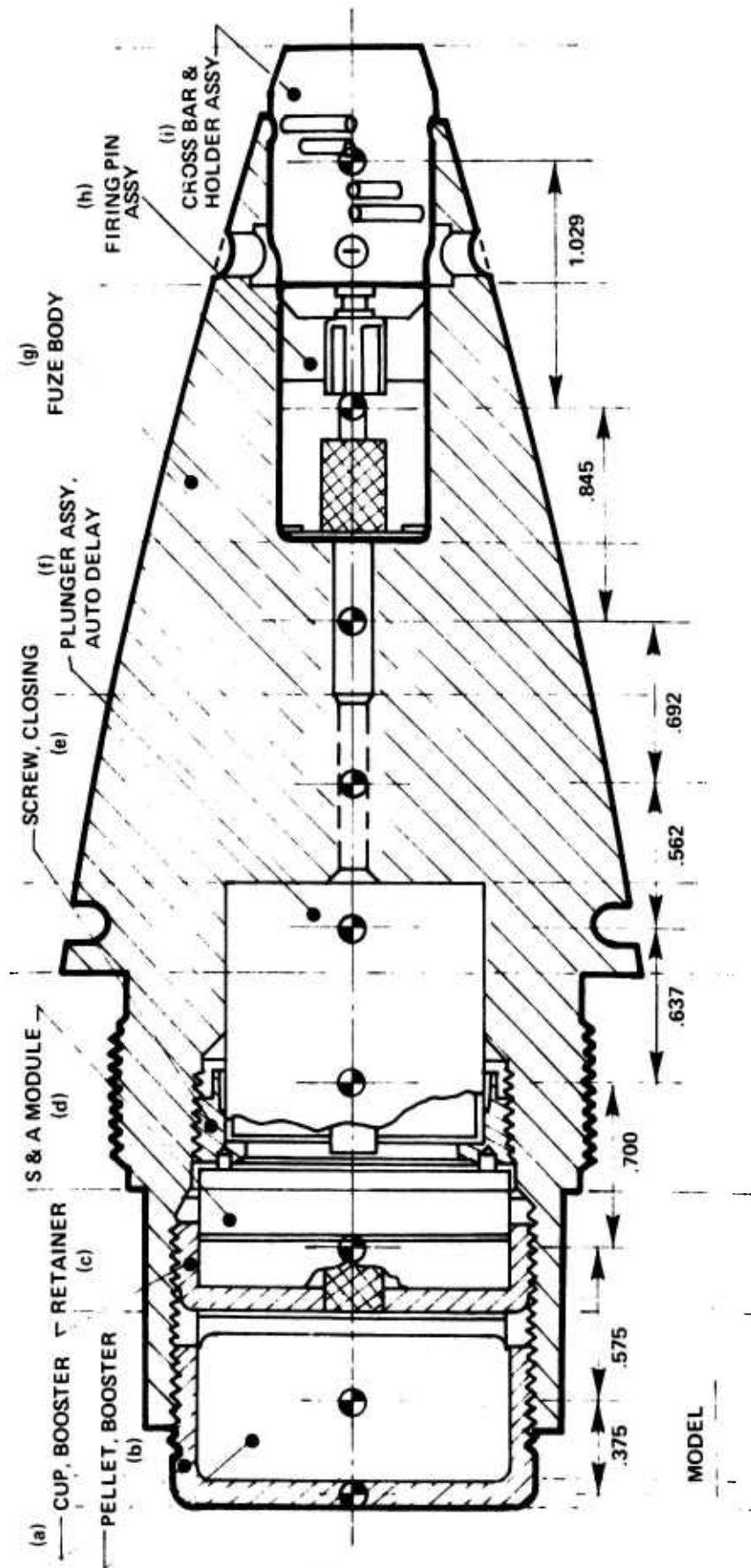

Fig 11A Lumped parameter system for fuze M572E2

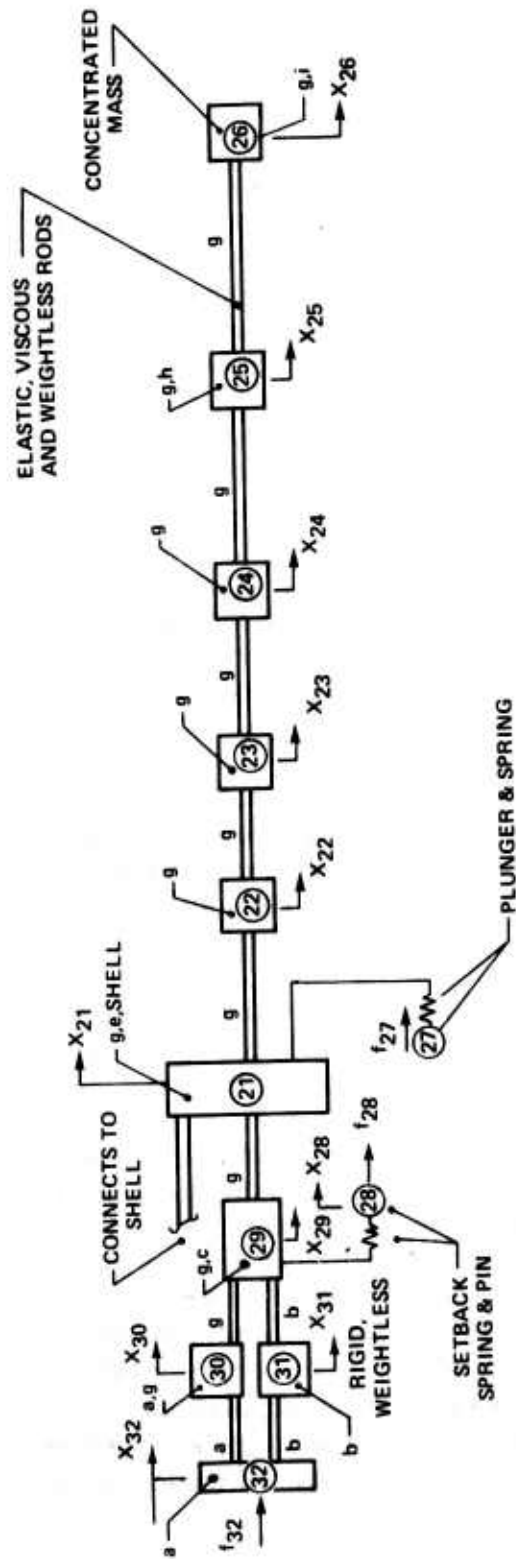

Fig 11B Lumped parameter system for fuze M57E2 (cont)

The S&A was analyzed and it was determined that the principal components in the setback-pin problem area include the setback pin, cavity, aluminum-alloy dimpled retainer cap, setback-pin spring, and the S&A rotor.

The failure mode analysis was limited to the postulation of potential response motions of the setback pin which could lead to or result in the failures noted during the field tests. This analysis was conducted to establish potential failure modes so that the dynamic math model which was to be developed to investigate component responses would have the capability of simulating all of the potential failure modes.

The three basic conditions which have to be met in order for the setback pin to reseat prior to sufficient S&A rotor motion are described below.

1. The setback pin must have had applied transverse loads which oppose the centrifugal loads holding the setback pin against the cavity wall. As a result of these transverse loads, the pin must be moving toward, or be in a position of alignment with, the S&A rotor re-seating pin hole.

2. During this period of eminent realignment, the setback pin must have acquired an axial impulse or have an axial component of velocity which will lead to either a repetition of these two states (as would be the case if rebounding back and forth across the cavity while moving forward), or direct reseating.

3. Upon reseating, the setback acceleration must not be sufficient to overcome the setback-pin spring force and any frictional force resulting from the pin-rotor contact.

Consideration of the type of model which would simulate setback-pin response motion led to the decision to model only the one-dimensional (axial) pin motion degree-of-freedom. This approach was necessitated by the scope of the contracted effort and the realization that out-of-line (i.e., 2- or 3-dimensional) effects, such as collision with the cavity wall pin response motion in the centrifugal field, would yield results which could be anticipated without the necessity of detailed analysis. These anticipated results are those described as condition 1, above. The motion of the pin toward the alignment position could be caused by rebounding, inbore laterally induced loads, muzzle-exit loads, or

residual precessional motion after muzzle exit. The resulting lateral motion was considered very probable; consequently, the approach taken in the modeling analysis was to determine what other response would occur if the setback pin were to achieve a position of alignment.

In the actual math model, the pin is treated as a point mass and has only unidirectional (axial) motion. Collisions occur only with the cavity top and bottom, initially assumed to behave in a perfectly elastic manner. The pin is allowed freedom-of-motion across the cavity, but such motion is not modeled. The potential failure mode, therefore, stemmed from the ability of the pin to line up and the potential of receiving axial environments which direct the pin toward the reseating position.

A math model was generated which permitted investigation of all the potential failure modes. The lumped-parameter math model which was developed represented the 8-inch howitzer shell, filler material, fuze structure, and pertinent component parts. A total of 33 mass points, or degrees-of-freedom, was used in this model.

At this point in the analysis, a simplifying assumption was made which permitted deterministic indications of setback-pin malfunction to be obtained. As pointed out in the failure-mode analysis, two conditions, alignment and forward axial motion, were a necessary prelude to setback pin reseating. A dud could not occur without both conditions being met. However, actual dud occurrence, as indicated by the test results, is statistical. This could well be due to the pin's rebounding motion back and forth across the cavity. Therefore, the assumption was made that, on a statistical basis, the setback pin would be in a position of alignment or impending alignment. It would then be possible to determine whether or not the other necessary condition, axial motion, was present and could cause setback pin reseating.

The model includes elastic collisions of the pin in bottoming out and reseating impacts. Another subsystem included in the model is the supplemental charge in its relative motion within its cavity toward the fuze. The retaining leaf spring operates in two stiffness zones due to the bottoming out of the center section. This sudden change in stiffness can result in an impulse being applied directly to the boosting charge cap which, in turn, could excite unwanted setback-pin response (see Fig 12).

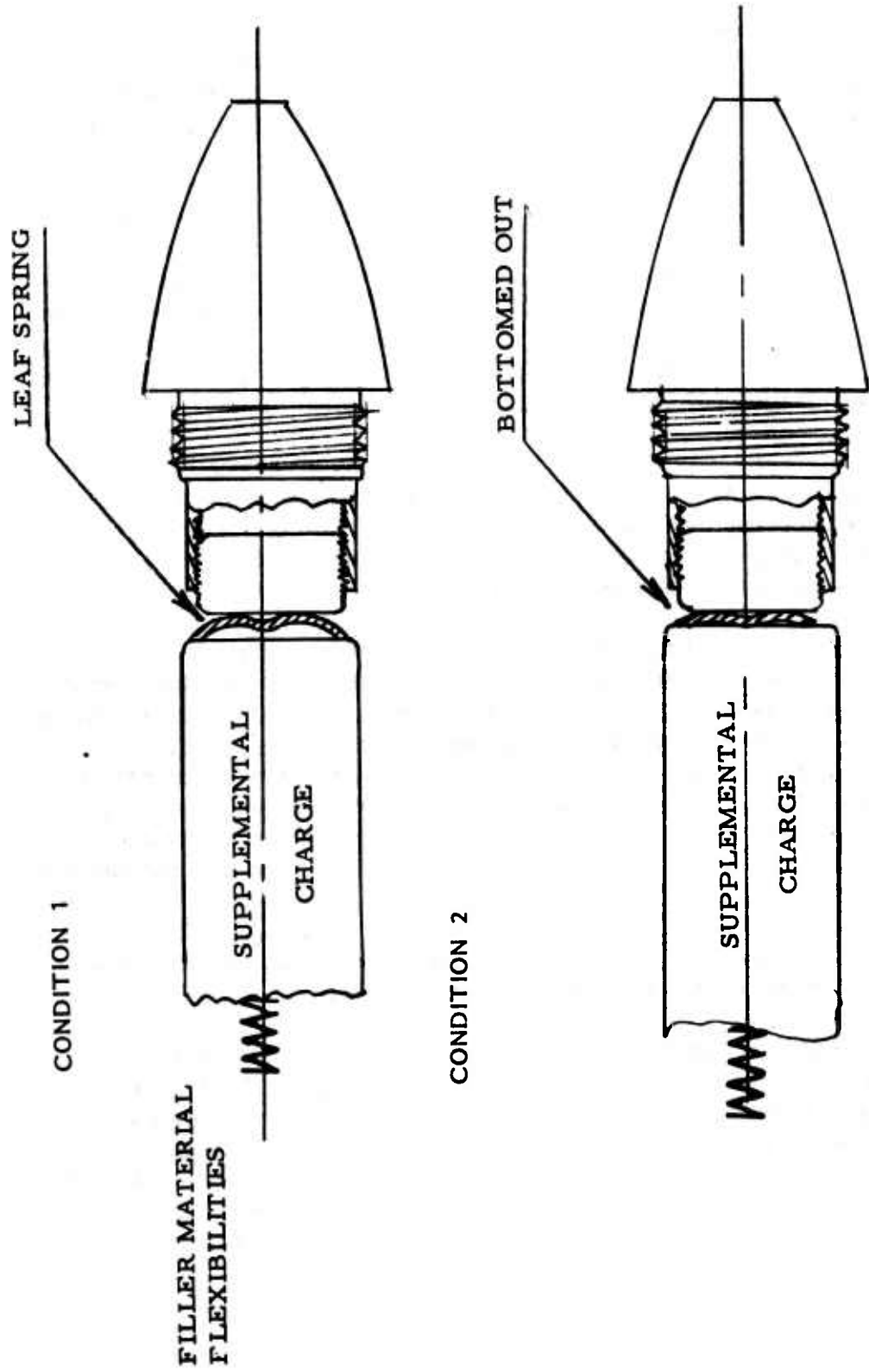

Fig 12 Supplemental charge model

The M572E2 sequencing and structural response analysis phase of the study involved exercising the math model for the purpose of observing the response of the setback pin under the action of the inbore environments. Basically, the coupled nonlinear differential equations of motion were written for each coordinate and solved using numerical integration. Two basic data output formats, digital and graphical, were utilized. The data generated for both outputs was extensive.

The first runs for setback-pin response were conducted for zone 1 firings. The nonlinear bottoming out and reseating events were assumed to be purely elastic. The basic response of the pin under the zone 1 loading conditions involves continuous elastic impacts and rebounding actions. As the projectile accelerates, the setback pin moves back into the pin cavity and impacts the retaining cap with a relative velocity. The pin rebounds toward the rotor and is accelerated by the compressed setback-pin spring. The acceleration of the projectile is greater, however, and sequential rebounds occur as the projectile moves down the barrel.

It was found from this run that the setback pin is periodically in the vicinity of the reseated position. This situation constitutes a potential dud condition. In other words, the presence of the axial elastic rebound phenomenon could cause repeated reseating. The significance of this response is the fact that, in the absence of constraints stemming from lateral motion effects, sufficient axial motion can exist to allow the setback pin to reseat before and after barrel exit.

Several other pertinent results were noted from this run including the following:

1. Although the supplemental charge bottomed out against the aft fuze section, the resulting impulse was not significant.
2. The structural response of the projectile under the applied loading environment of zone 1 was negligible; therefore, the elastic rebounding of the setback pin would occur independent of the projectile's structural flexibility.
3. This run took approximately 30 minutes of computer time, indicating that it would be very time consuming and expensive to conduct an extensive parametric study with this model.

In view of the fact that the structural flexibility appeared negligible for the zone 1 simulation, this model was downgraded to a much simpler model consisting of only three degrees-of-freedom (Fig 13). This model was exercised for the same conditions in order to compare setback-pin responses. The response was essentially identical to the response generated by the 33 degrees-of-freedom system. Consequently, the simpler model was used to investigate pin response as a function of simulated engineering design changes.

The setback-pin parametric study involved exercising the model to determine the effects of several candidate engineering-design changes. The design changes to be studied included:

1. Added damping to the motion of the setback pin while the pin is moving between its axial boundaries.
2. Changing the stiffness of the setback-pin spring.
3. Increasing the setback-pin stroke.

Five runs were made with increased damping for the setback-spring motion between boundaries, while keeping boundary collisions with zero damping (perfectly elastic). This was recognized to be a very conservative assumption. The rationale involved searching for a positive fix to the problem which would effect a solution under the worst conditions. (These conditions included perfectly elastic rebounding and continuous lateral alignment.) Relative damping ratios of 25-, 50-, 100-, 1,000-, and 10,000- percent critical were investigated. The time for initial reseating ranged from almost immediately after muzzle exit for 25 percent critical, to about five milliseconds for 100 percent, to about 54 milliseconds for 1,000 percent. One of the pertinent results demonstrated by these solutions is that if the pin comes to a position of alignment for any of the reasons discussed above, even without rebounding motion, the setback-pin spring itself can cause reseating shortly after muzzle exit. The 25-, 50-, 100-, and 1,000-percent critical conditions are illustrated in Figures 14, 15, 16, and 17, respectively, where muzzle exit occurs at 29.5 millisecond (0.0295 time). The ordinate "0.25" represents pin bottoming, and the ordinate "0.13" represents seating of the pin in the rotor. For pin motion unrestrained by friction forces along the cavity wall, it was apparent that significant dash-pot type damping is required to guarantee successful operation after the shell leaves the muzzle.

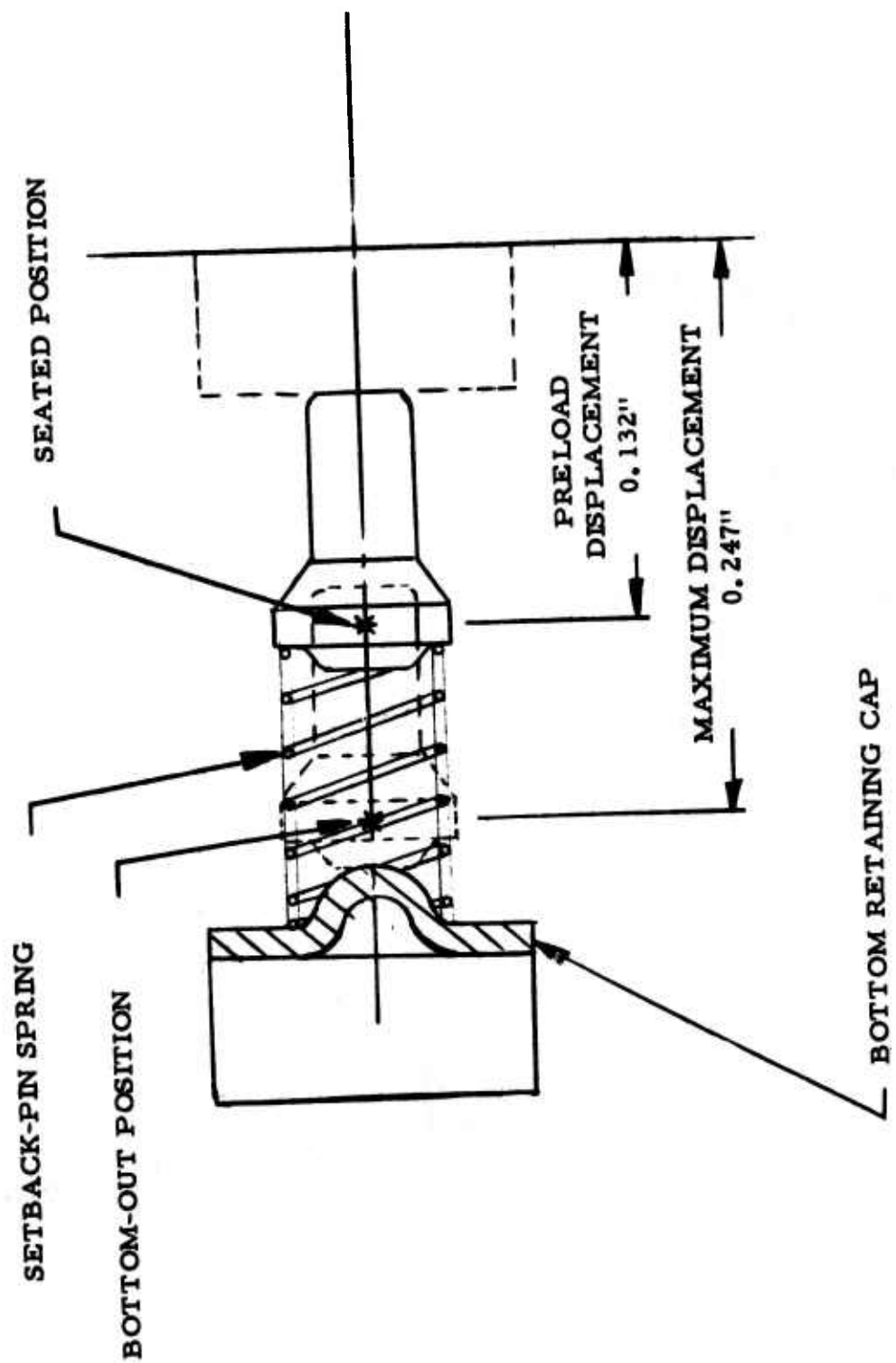

Fig 13 Setback-pin model

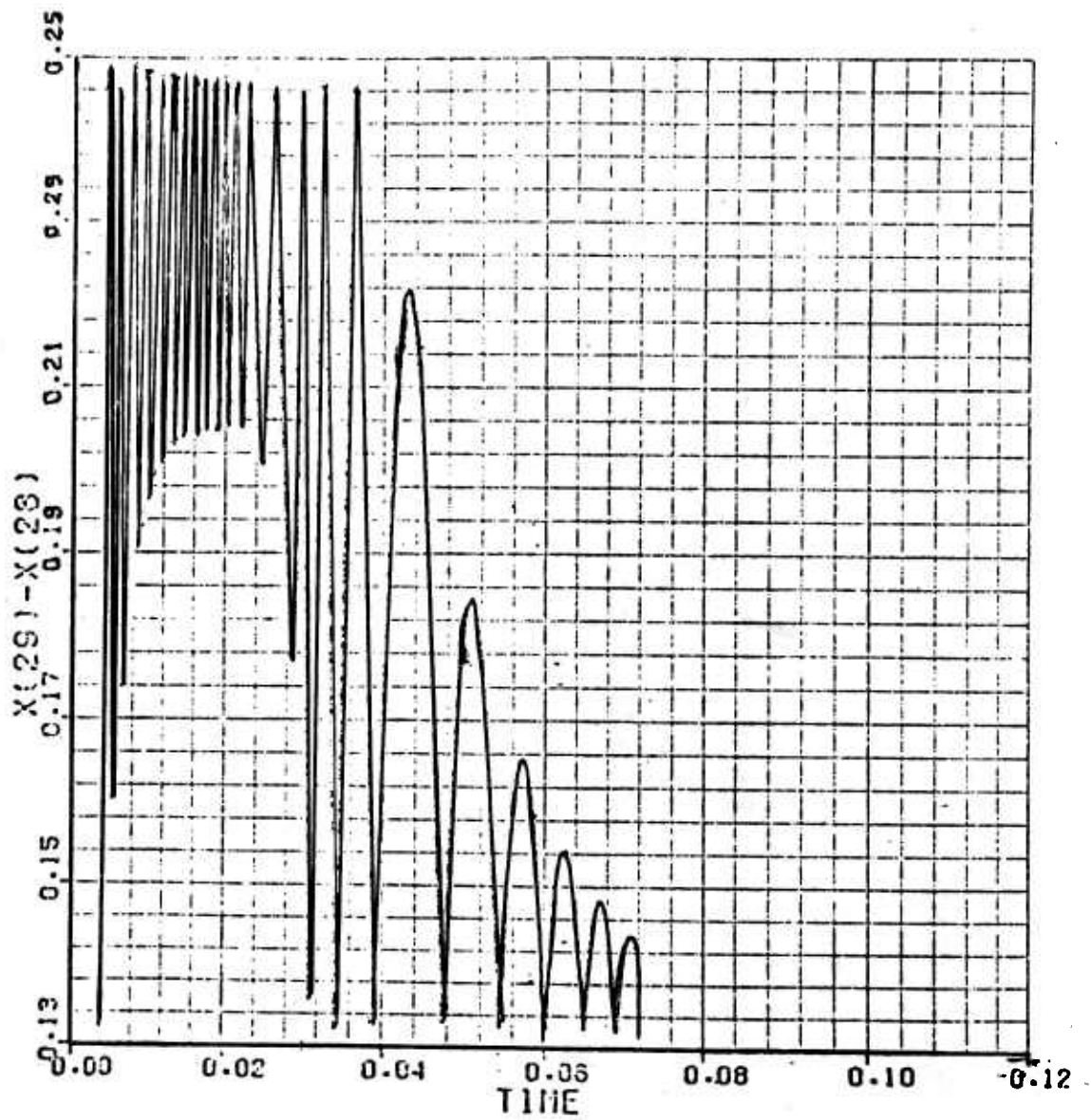

Fig 14 Setback-pin response $\zeta = 25$ percent

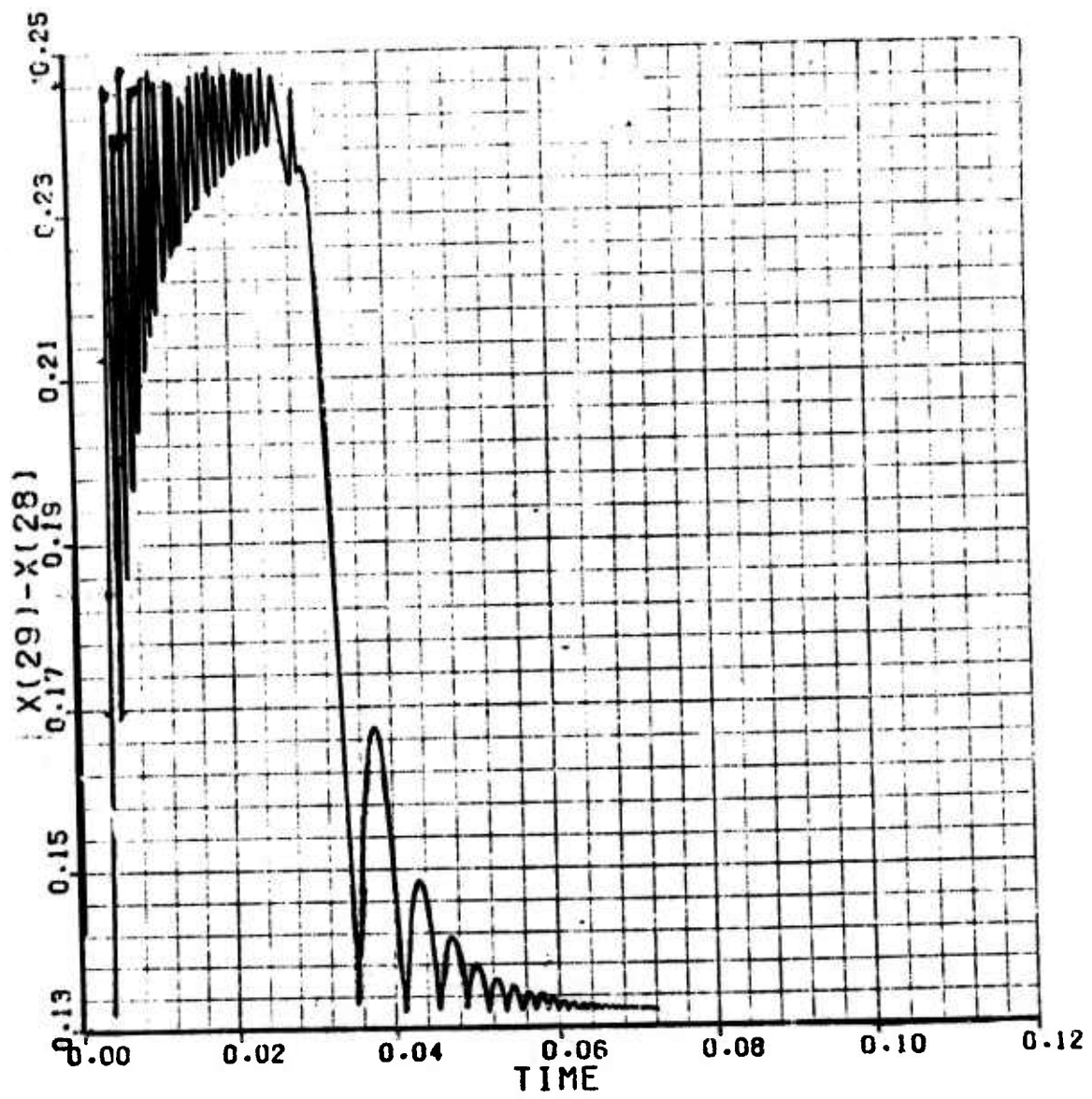

Fig 15 Setback-pin response $\zeta = 50$ percent

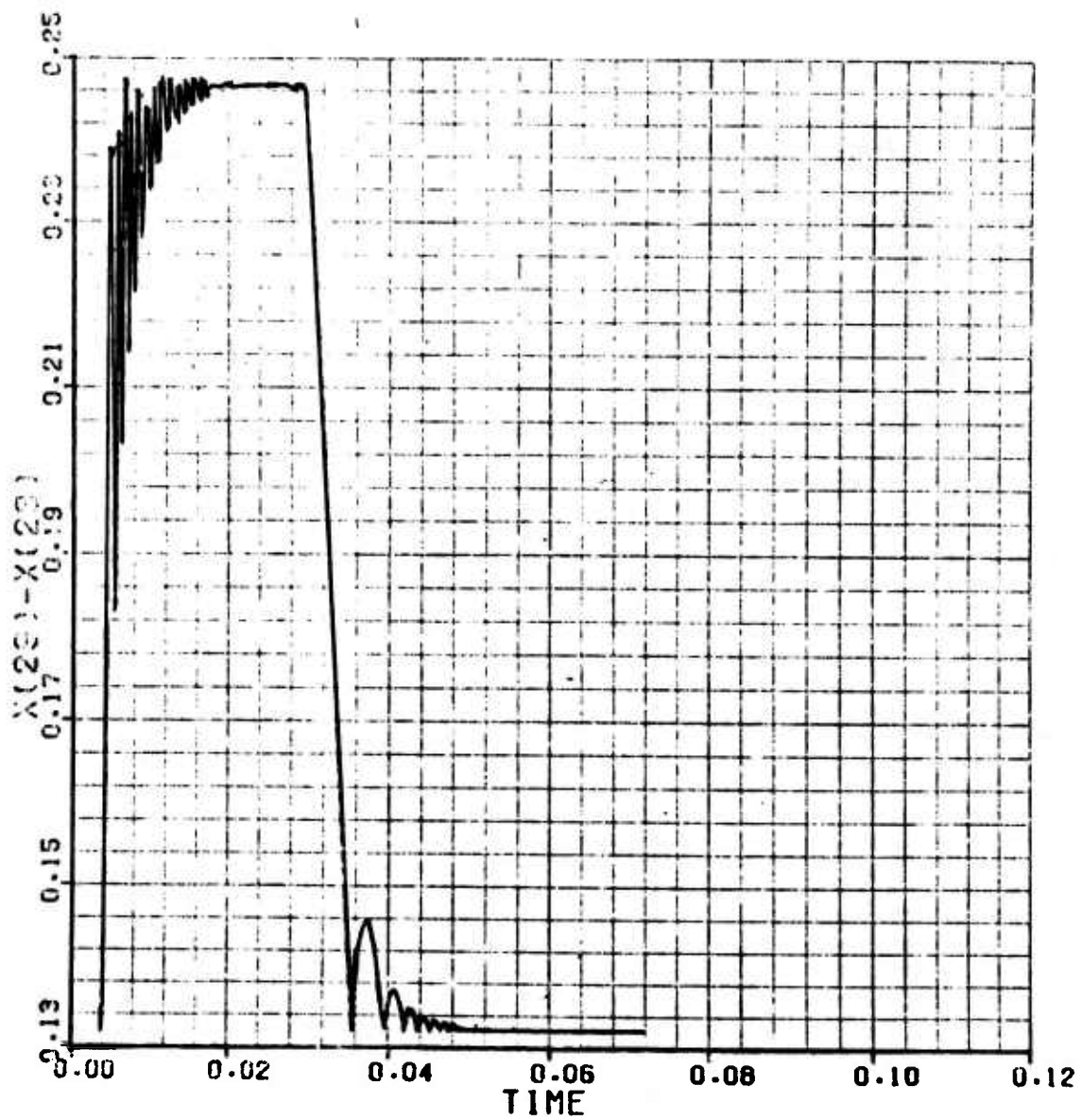

Fig 16 Setback-pin response $\zeta = 100$ percent

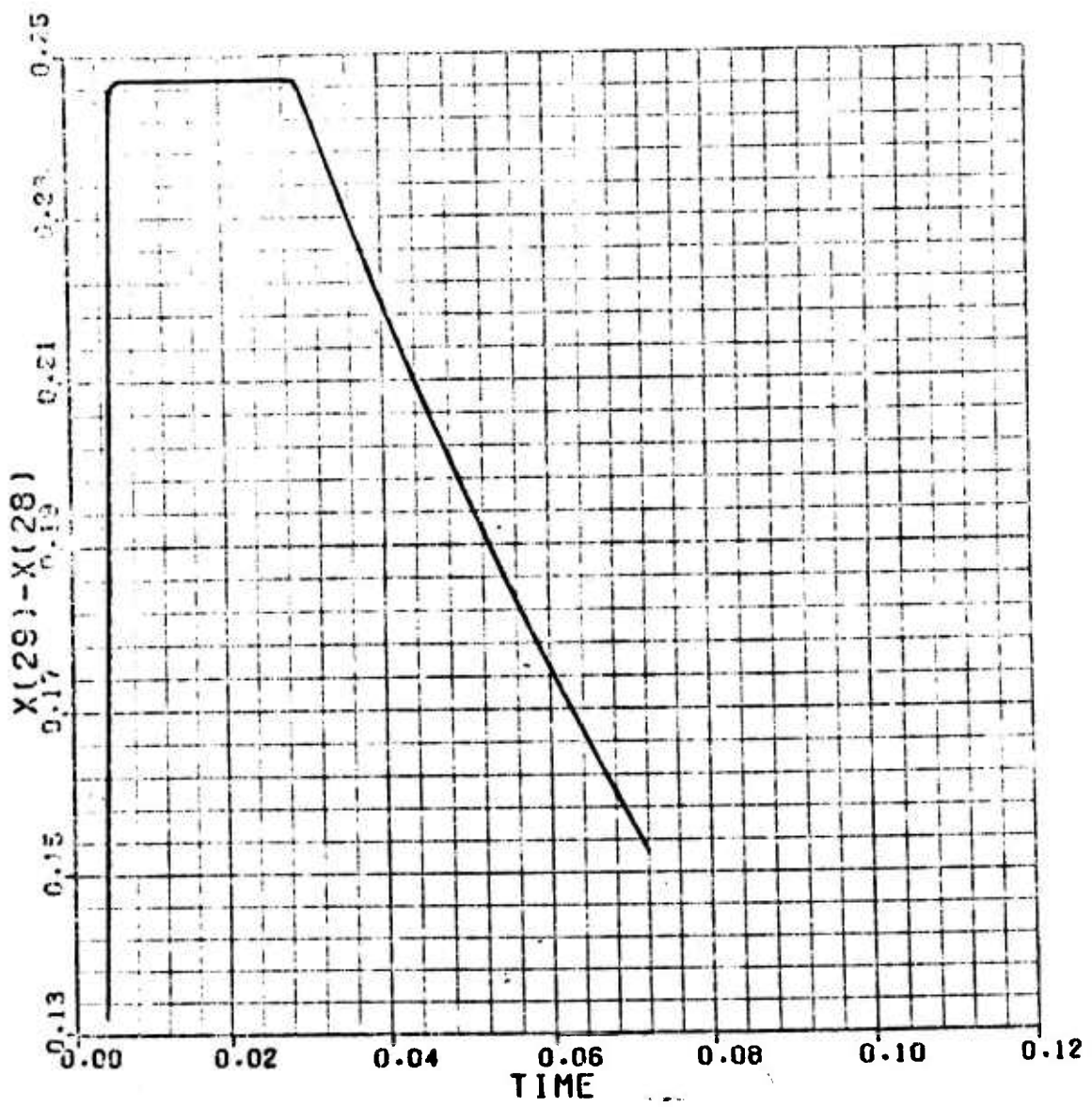

Fig 17 Setback-pin response $\zeta = 1,000$ percent

Two setback-pin springs, 20G and 5G, were investigated as possible replacements for the then-current 36G spring to determine the effect of setback-spring stiffness. The setback pin has its initial reseating after about a millisecond for the 20G setback-pin spring (Fig 18) and eight milliseconds for the 5G setback-pin spring. The damping utilized in this investigation was 25-percent critical relative to the 36G system. The reseating delay is associated primarily with the higher relative damping and the effects of the velocity shocks; although the lower stiffness helped, its effect was not very significant.

In the investigation of increased stroke, the dimple retaining cap, which utilizes a significant fraction of the potential stroke of the setback pin, was replaced with a flat section. Stroke lengths of 0.216, 0.247, 0.272, and 0.632 inches were studied. The results indicated that the model was not suited for this investigation for the following reasons:

1. The effect of increased stroke would have more influence on lateral motion than upon axial response.
2. Removal of the retaining cap would allow bottoming out to occur on the coil spring. The rebounding associated with this type of impact would not be nearly as elastic as pin-cap impacts.

In summary, the AVCO Systems Division analysis identified two potential failure modes and two candidate fixes for the setback-pin problem. The potential failure modes were:

1. Setback-pin reseating due to residual rebounding motion, and
2. Reseating shortly after muzzle exit due to a combination of lateral pin motion toward a position of alignment and the force of the setback-pin spring itself.

Two suggested modifications in the present design included:

1. Reducing the potential of elastic rebound, and
2. Increasing the time duration for the pin to return to the reseating position.

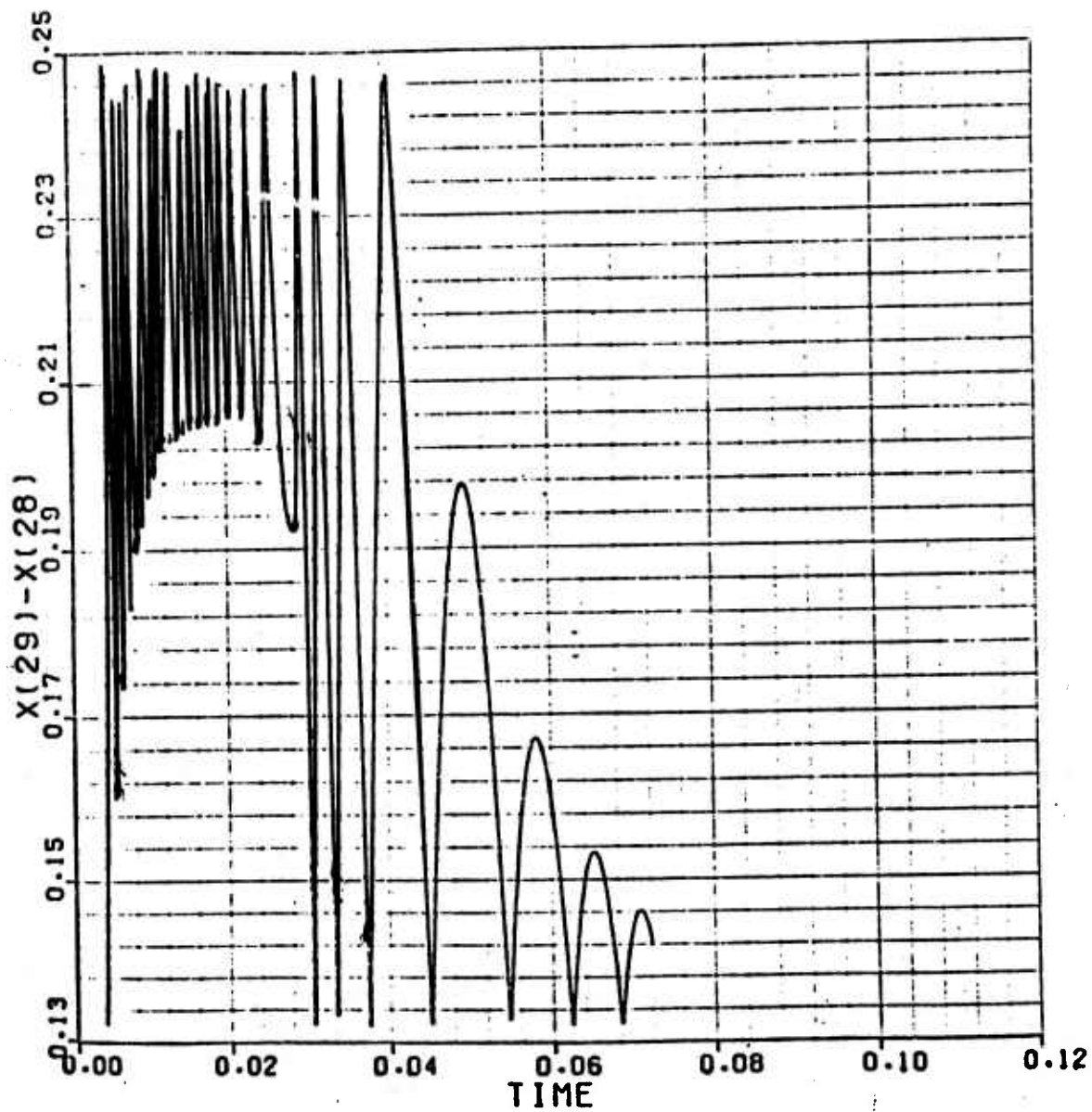

Fig 18 Setback-pin response $\zeta = 25$ percent, $k \rightarrow 20$ g's

Several other related aspects of the problem were identified during this study. One had to do with what AVCO feels was the initial step which lead to the cited M572E2 fuze dud difficulties, i. e., a lack of knowledge of the precise environments experienced by the projectile, the S&A, and fuze components during the handling, inbore, muzzle exit, in-flight, and impact phases of a ballistic firing. In particular, the centrifugal field which is used as a principal environment to effect setback-pin functioning in some cases is probably orders-of-magnitude lower than some of the inbore, laterally induced forces and may be comparable to the lateral in-flight environments stemming from precessional motion. AVCO, therefore, recommends that programs which will better define these environments be continued.

Another aspect of the problem is related to the type of solution which should be sought to enhance the functioning characteristics of the M572E2's S&A system.

As indicated in AVCO's report, the response motion of the setback pin is statistical in nature. Solutions which tend to simply reduce the probability of duds should be avoided; instead, solutions which result in a positive fix to the problem should be the objectives.

Dynamics of Setback Pin During Firing

Honeywell, Inc., was requested to perform an analytical investigation of the M572E2 fuze dud problem, due to S&A failures, about the same time as AVCO Systems Division. This request was made because Honeywell was the contractor for the M572E2 fuze Product Improvement Program and had extensive experience in this type of analytical work. Much of the Honeywell and AVCO work was done in parallel, e.g., Honeywell was informed, while their effort was in progress, of AVCO's determination that the setback pin was rebounding in the tube.

The analytical approach taken by Honeywell to help solve the problem was to investigate the dynamics of the setback pin during firing. A math model was developed to determine how the pin responds to the firing environment. The math model consists of a series of submath models, each suitable for a specific phase of the environment.

Experimental data on rotor response indicates that the position of the rotor is such that pin reinsertion could occur up to 80 milliseconds after firing (Fig 19). Thus, the dynamic behavior of the pin was studied over this period of time and the assumption accepted that, should the pin move forward to a point where its tip crossed the lower plane of the rotor, the condition of failure would be achieved.

The seven math models which were generated are discussed below. The dynamics of eight versions of the setback pin were studied and the analysis shows some significant differences in pin behavior which are in substantial agreement with field firing results.

The setback-and-bounce math model describes the dynamics of the setback pin during the first 10 milliseconds. The purpose of this analysis was to determine how soon the setback pin moves aft and whether or not bounce could cause the pin to re-engage the rotor. It was concluded that, under normal setback conditions, the setback pin moves to its aft position in less than one millisecond and starts a succession of bounces of decreasing magnitude. The pin returns only about half the distance to the rotor, thus presenting no possibility for reinsertion, and comes to rest in approximately five milliseconds. This parabolic type bounce of decreasing magnitude is illustrated in Figure 20 for the tungsten pin design. The results are similar for the original steel pin and dimpled aluminum-disc design. The friction coefficient between pin and cavity wall was considered zero. Also, a high coefficient of restitution (.75) equivalent to a damping factor of only 9 percent was used when the pin collided with the bottom of the pin cavity. These results differ from AVCO's because AVCO had assumed an effective friction coefficient between pin and cavity sidewalls by use of a damping factor, but AVCO had a coefficient of restitution of one for perfectly elastic collisions when the pin collided with the bottom or top of the cavity. (The measured coefficient of restitution for the tungsten pin against a soft, flat, aluminum cavity base was only about 0.2 for the aluminum disc held only by stake, but increased to about 0.5 or 0.6 when a simulated booster was tightened against the back of the staked aluminum disc.)

The tip-over math model described how the pin rotates after cessation of setback to place its tip behind the ramp for a cavity with a flat bottom. The model showed that, when the pin and cavity bottom both have a flat

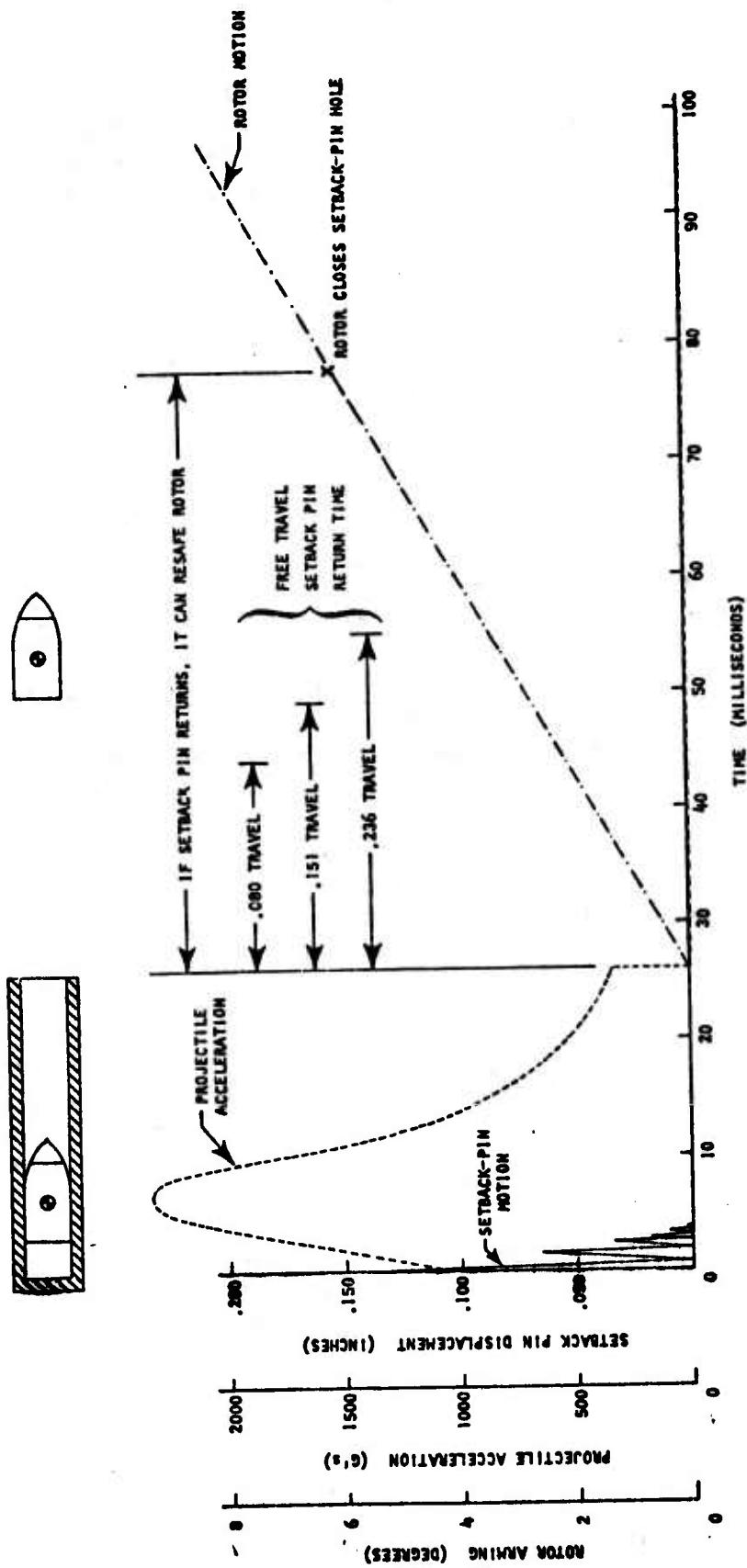

Fig 19 Low G setback-pin response to 8-inch zone 1 firing

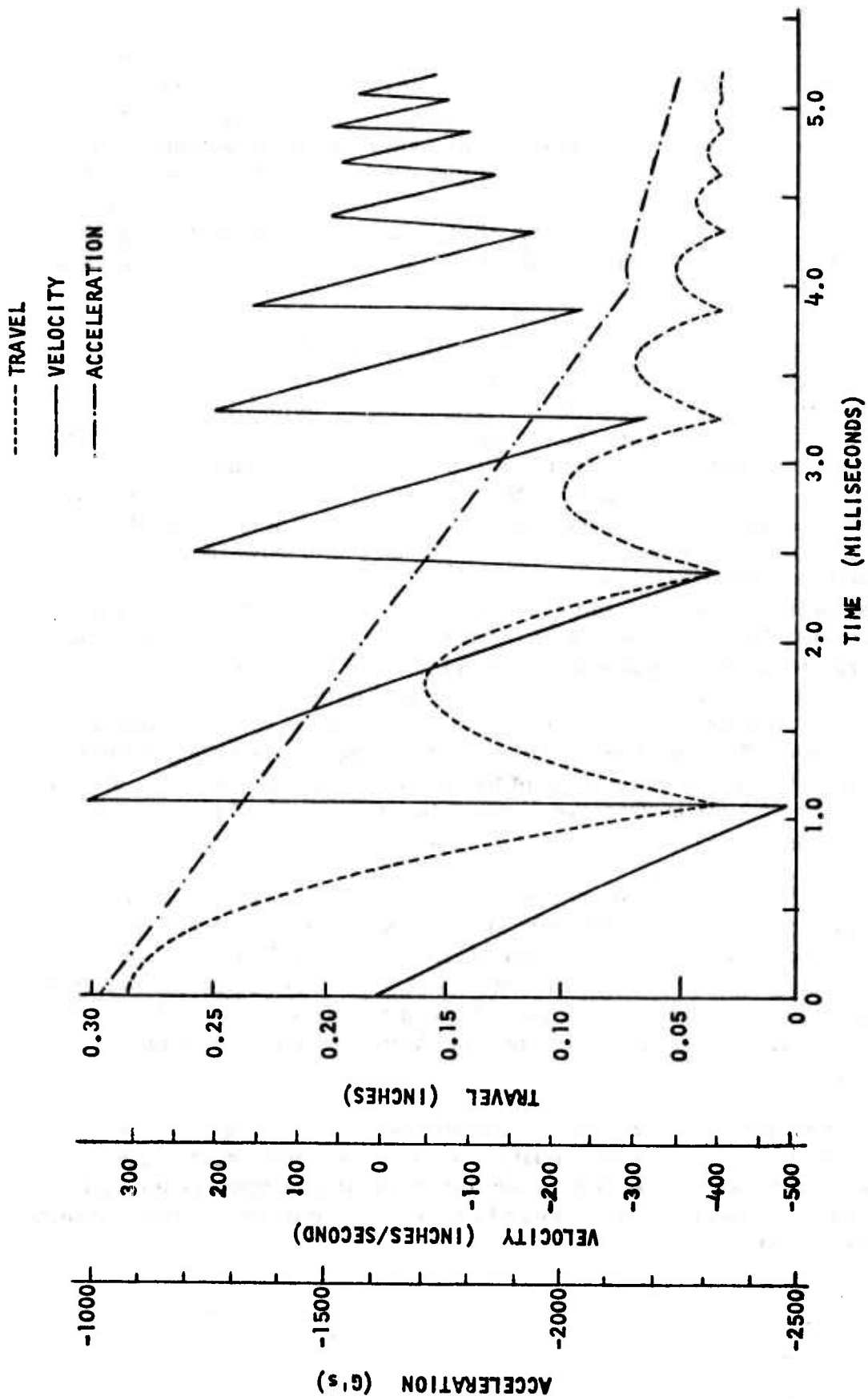

Fig 20 Parabolic-type bounce for tungsten setback-pin design (PA-34)

surface, centrifugal acceleration is insufficient to cause the pin to tilt toward the wall while the projectile is still in the barrel. Thus, for such a configuration, the pin will remain bottomed, but upright. On exit, the setback acceleration disappears, and centrifugal force will act to tip the pin. The model showed that six of the eight pins will tip over in about two milliseconds. The slide program, discussed below, indicated that in most cases, for a long cavity, the pin will not have reached the ramp position by that time; therefore, the tip of the pin will be trapped behind the ramp.

The slide math model describes the dynamics of the setback pin as it slides forward as a point mass under the action of the return spring, centrifugal force, and sidewall friction. Computations were made to determine the time required for the pin to move forward to engage the rotor, assuming no interaction with the ramp. This could be the case if the pin, through some combination of impulses, were perfectly aligned with the upper hole in the cavity. A computer run was also made to determine the time required for the setback pin to move from its aft position to the point where its tip strikes the ramp. This math model shows that the setback pin with a long stroke takes approximately double the time, 10-11 milliseconds vs. 4-6 milliseconds for other setback pins, to return without ramp interaction to the rotor reinsertion point. Since rotor reinsertion is possible up to nearly 50 milliseconds after barrel exit, all the setback pins (for a no-ramp condition) could re-engage the rotor. The time required to reach the ramp shows a similar difference. It also shows that the velocity of the pin at the time of contacting the ramp is higher for the long stroke systems than the others. This data was required to provide the initial conditions for the ramp-impact math model.

In the ramp-impact math model the conditions of impact of the pin against the ramp are important, since such an impact could cause the pin to bounce. It is also possible that, with a sufficient initial velocity remaining after impact, the pin could continue to slide up the ramp even though frictional forces may exceed the spring force. The velocity of the pin after impact was found by calculation to be approximately $1/3$ the approach velocity.

The ramp math model describes the behavior of the pin under the action of the spring, centrifugal force, and frictional forces of the sidewall and ramp. It was found from this model that, under certain conditions, the setback pin's forward tip moves up the ramp a short distance and then stops.

The transverse acceleration or setback pin math model examines the effect of a general transverse acceleration on the setback pin. The ramp model showed that, under the specific radial transverse (centrifugal) acceleration, the pin remains trapped behind the ramp. On the other hand, a transverse acceleration of greater magnitude directed opposite to the spin could move the pin off the ramp. This math model showed that the setback pin with a relatively forward center of gravity and small initial tilt angle moves to an angle which aligns the pin in two milliseconds, as compared to 10 milliseconds for a pin with a lower center of gravity and large tilt angle. It is further shown that, with a still lower center of gravity, the pin will rotate in the opposite direction.

The final slide phase uses the same math model as slide, except for a different set of initial and final conditions. The initial pin position is taken as that location where the pin reaches alignment in the transverse acceleration math model. The pin is then assumed to slide forward under the action of the spring to the point of rotor engagement. The computer run for this phase was not completed during the course of the investigation.

In summary, the Honeywell analysis showed that the setback pin responds to balloting (transverse loading) in a manner which could permit reinsertion of the pin into the rotor. The analysis further showed that a setback-pin design with a lower center of gravity might alleviate this condition. The field test data on a variety of setback pins appeared to confirm the performance predicted by the dynamic analysis.

Supporting Programs

A number of in-house supporting efforts were conducted during the course of the investigation. These efforts, which are listed below, contributed to the resolution of the problem, but are not discussed in detail in this report.

1. Shock test of S&A module to establish rotor-lock pin integrity.
2. Spin test of S&A rotor and setback pin.
3. Dimensional analysis of S&A module.
4. Studies of the use of grease in the S&A.

5. Studies of the setback-pin motion and forces, rotor-lock pin strength, and spin decay.
6. Review of setback-pin surface finish and uniformity.
7. Review and analysis of the setback pin and cavity configurations.
8. Review of the rotor-lock pin material and design.
9. Analysis of the design for the purpose of eliminating pressure on the S&A from the booster.
10. Vibration attenuation tests.
11. A complete series of MIL-STD-331 environmental tests.
12. A complete fuze explosive-train propagation test performed in both SQ and delay modes.

ANALYSIS OF RESULTS

From analytical studies and low-zone ballistic tests, the present explanation for duds caused by the setback pin appears to be as follows:

On firing, the setback pin in both the old (steel pin) and new (tungsten pin) cavity-pin designs settles down in its bottomed position away from the rotor early in the internal ballistic cycle, even with a high coefficient of restitution of 0.9. In the original pin design with the short cavity and aluminum dimpled cavity base, the realm of marginality for 8 inch, Zone 1 firing was being approached, even though a sudden lateral motion of the shell as it reached the muzzle was excluded from consideration.

As the muzzle is reached, the number of setback and spin acceleration G's become comparable. If tube vibration or balloting impact of sufficient magnitude occurs just before the muzzle is cleared by the shell (depending on the orientation of the pin cavity at that instant), the cavity sidewall against which the pin is resting (for the dimpled-type cavity base design) suddenly moves away from the pin, and the opposite side of the pin strikes the opposite cavity wall. This can result in the pin rotating itself upright (or beyond for a pin with a high center of gravity).

If the cavity base is flat, lateral forces just before muzzle exit could start a rattling of the pin in its bottomed position. If setback ceases while the pin is in this rocking type motion, although spin is operating to keep the pin against the wall, the pin may experience intermittent separation from the cavity wall as the spring pushes the pin upward, resulting in effectively decreasing the friction coefficient. The friction force attempts to decelerate and stop the pin as it moves up the sidewall.

A very complicated pin motion can ensue near the muzzle if the shell experiences lateral motion. A lowered pin center of gravity, a flat cavity bottom, and a large flat pin bottom help in preventing rapid tilting pin motions. An energy-absorbing cavity base, like the present soft aluminum, helps to dampen axial velocity components for the pin if it "rattles" in the bottomed position. (The way the spring is positioned on the pin bottom also exerts a small uprighting action on a tilted pin.)

An increase in pin density (i. e., tungsten as opposed to steel) was helpful in permitting a more rugged spring while still maintaining a low enough G-bias level. This change does not help in increasing pin deceleration for sliding pin motion upward along the cavity wall.

An increase in stroke length would increase the distance over which the spring accelerates the pin, permitting the pin to attain higher velocity toward the rotor. However, it would also provide the necessary distance for the pin to restore contact along the side surface, after some initial lateral bouncing, and for some optimum length it could cause sufficient deceleration of the pin through friction force. Making the ramp angle more abrupt, as in the final design, also adds another deterrent to pin reseating.

CONCLUSIONS

After significant diagnostic testing and analysis, it was concluded that the M572E2 fuze duds encountered during low-zone firings of the 155 mm and 8-inch howitzers were due to the setback pin re-engaging the rotor. This occurred before the rotor had a chance to move a sufficient distance to prevent re-engagement. This was considered to be caused by lateral rebounding of the setback pin from the shell-tube side forces, and insufficient contact force between the setback pin and the side of the cavity under low-spin conditions.

It was determined that the problem could be resolved by the following primary design changes:

1. The center of gravity of the setback pin was lowered by increasing the size of its base. This change increases centrifugal force and retards the uprighting rotation of the pin when lateral side bounce occurs inbore near the muzzle. Also, a heavier material (tungsten) was used to permit the use of a more readily producible spring.

2. The travel distance of the setback pin was increased by decreasing the length of the setback pin and increasing the length of the setback-pin cavity. This was done to enhance complete stoppage of pin motion, either along the cavity wall or on the ramp.

3. A flat, energy-absorbing material was put into the base of the setback-pin cavity. This was done to further dampen any bounce the setback pin may experience.

Three secondary changes were also made: The G-level of the setback-pin spring was reduced to lower the reseating force on the setback pin; the staking for the rotor gear rivet pin was relocated inboard to prevent interference of the rotor and setback pin, and a more abrupt angle was used in the setback-pin cavity.

It was also concluded that analytical programs such as those performed by AVCO Systems Division and Honeywell are of significant value in the resolution of problems involving fuze systems.

RECOMMENDATIONS

Within the past four years, the use of lumped-parameter analysis has provided significant insight into the problems of the M572E2 as well as several other fuze systems. In view of the success of this type of analysis, the following is recommended:

1. Analytical programs for the M57?E2 fuze should continue to be developed and refined.

2. During the investigation, evaluation, or design of any S&A or fuzing system, the utility of analytical procedures should be recognized and applied at appropriate times during the program.

3. Efforts should be continued to obtain more accurate and reliable descriptions of the environments (handling, inbore, muzzle exit, in-flight, and terminal impact) used to initiate and affect functioning of S&A and fuze components.

4. The functioning or design philosophy of selected S&A and fuze systems (both existing and future) should be reviewed in the light of a better understanding of the environments assumed to affect sequencing.

APPENDIX A
1972 EQUIPMENT PERFORMANCE REPORTS (EPR'S)
FOR FUZE M572E2

EQUIPMENT PERFORMANCE REPORT

1 FROM President US Army Field Artillery Board Fort Sill, Oklahoma 73503		2 OFFICE SYMBOL: STEBA-TD																										
		3 DATE: 24 July 1972																										
		4 EPR NO. KE-1																										
5 TO SEE DISTRIBUTION LIST		6 USATECOM PROJ NO. 2-MU-007-572-012																										
		ROTB E PROJ NO. ---																										
		CONTRACT NO. ---																										
7 TEST TITLE Product Improvement Test of Fuze, PD, M572E2																												
I. MAJOR ITEM DATA																												
8 MODEL Fuze, Point Detonating, M572E2		9 SERIAL NO. ---																										
10 QUANTITY 900		11 LIFE PERIOD 515 fired																										
12 MFR. Honeywell		13 USA NO. Lot MHR-1-2																										
II. PART DATA																												
14 NOMENCLATURE/DESCRIPTION Fuze, Point Detonating, M572E2																												
15 FSM ---		16 MFR. PART NO. ---																										
17 DRAWING NO. ---		18 MFR. ---																										
19 QUANTITY 19 w/8" Howitzer, 6 w/155mm Howitzer		20 NEXT ASSEMBLY ---																										
21 STD GOVT. GRP. ---		22 PART TEST LIFE ---																										
III. INCIDENT DATA																												
23 OBSERVED DURING		24 TEST ENVIRONMENT																										
a. OPERATION		Clear, dry 90 - 97° F Quanah Range Ft Sill, OK																										
b. MAINTENANCE																												
X c. Preliminary Data Analysis																												
		25 INCIDENT CLASS																										
		X a. DEFICIENCY																										
		b. SHORTCOMING																										
		c. SUB. IMPROVEMENT																										
		d. OTHER																										
27 DATE AND HOUR OF INCIDENT 24 July 1972, 1300		26 ACTION TAKEN																										
		a. REPLACED																										
		b. REPAIRED																										
		c. ADJUSTED																										
		d. DISCONNECTED																										
		e. REMOVED																										
		X f. NONE																										
IV. INCIDENT DESCRIPTION																												
28 DESCRIBE INCIDENT FULLY																												
<p>During preliminary analysis of test data, USAFABD test personnel noted a high malfunction rate (duds plus mine actions) at zone 1 in the test item compared with the standard item. The test item malfunctions occurred during firings at zone 1 from the M110 8-inch howitzer (minimum spin condition) and at zone 1 from the M114A1 155mm howitzer (minimum setback condition). The test item malfunction rate is considered a deficiency because it indicates improper design which seriously impairs the test item's operational capability from the M114A1 and M110 howitzers at zone 1. The zone 1 firing results from the M110 and M114A1 howitzers and the associated reliabilities are as follows:</p> <table border="1" style="width: 100%; margin: 10px 0;"> <thead> <tr> <th>ITEM</th> <th>WEAPON</th> <th>ROUNDS FIRED</th> <th>NUMBER OF MALFUNCTIONS</th> <th>OBSERVED RELIABILITY (%)</th> </tr> </thead> <tbody> <tr> <td>Test Item</td> <td>M110</td> <td>83</td> <td>19</td> <td>77.11</td> </tr> <tr> <td>Std Item</td> <td>M110</td> <td>56</td> <td>2</td> <td>96.43</td> </tr> <tr> <td>Test Item</td> <td>M114A1</td> <td>61</td> <td>6</td> <td>90.16</td> </tr> <tr> <td>Std Item</td> <td>M114A1</td> <td>53</td> <td>1</td> <td>98.11</td> </tr> </tbody> </table> <p>As stated in subparagraph 1.4.4 of the USAFABD test plan, the Board will request additional test items for the purpose of determining those zones adjacent to zone 1 at which the test item will function suitably. The Board will fire the following program</p> <p style="text-align: center;">DEFICIENCIES AND SHORTCOMINGS ARE SUBJECT TO RECLASSIFICATION (continued)</p>				ITEM	WEAPON	ROUNDS FIRED	NUMBER OF MALFUNCTIONS	OBSERVED RELIABILITY (%)	Test Item	M110	83	19	77.11	Std Item	M110	56	2	96.43	Test Item	M114A1	61	6	90.16	Std Item	M114A1	53	1	98.11
ITEM	WEAPON	ROUNDS FIRED	NUMBER OF MALFUNCTIONS	OBSERVED RELIABILITY (%)																								
Test Item	M110	83	19	77.11																								
Std Item	M110	56	2	96.43																								
Test Item	M114A1	61	6	90.16																								
Std Item	M114A1	53	1	98.11																								
29 DEFECTIVE MATERIAL SENT TO: NA																												
30 NAME, TITLE & TEL EXT OF PREPARER CLIFFORD J. EBY, MAJ, FA Project Officer 639-3231		31 FOR THE PRESIDENT: <i>Harold V. Madden</i> HAROLD V. MADDEN COL, FA Chief, Test Division																										

EPR KE-1
TECOM Project No 2-MU-007-572-012
24 July 1972

in addition to the firing program in the approved test plan in an attempt to isolate the conditions under which malfunctions occur.

<u>Weapon</u>	<u>Zone</u>	<u>Trajectory</u>	<u>FZ Action</u>	<u>No. of Rounds</u>
8" How	2	HA	SQ	10
8" How	2	HA	D	10
8" How	2	LA	SQ	10
8" How	2	LA	D	10
155mm, M114A1	2	HA	SQ	10
155mm, M114A1	2	HA	D	10
155mm, M114A1	2	LA	SQ	10
155mm, M114A1	2	LA	D	10

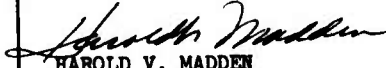
EQUIPMENT PERFORMANCE REPORT			
1. FROM President US Army Field Artillery Board Fort Sill, Oklahoma 73503		2. OFFICE SYMBOL: STEBA-TD	
		3. DATE: 31 July 1972	
		4. EPR NO. KE-1-S1	
5. TO SEE DISTRIBUTION LIST		6. USATECOM PROJ NO. 2-MU-007-572-012 RO'OE PROJ NO. -- CONTRACT NO. --	
		7. TEST TITLE Product Improvement Test of Fuze, FD, M572E2	
I. MAJOR ITEM DATA			
8. MODEL Fuze, Point Detonating, M572E2		9. SERIAL NO. --	
10. QUANTITY 900		11. LIFE PERIOD 611 Fired	
12. MFR. Honeywell		13. USA NO. Lot MHR-1-2	
II. PART DATA			
14. NOMENCLATURE / DESCRIPTION Fuze, Point Detonating, M572E2			
15. FSN --		16. MFR. PART NO. --	
17. DRAWING NO. --		18. MFR. --	
19. QUANTITY See attached chart.		20. NEXT ASSEMBLY --	
21. STO. GOVT. GRP. --		22. PART TEST LIFE --	
III. INCIDENT DATA			
23. OBSERVED DURING		24. TEST ENVIRONMENT	
a. OPERATION		25. INCIDENT CLASS	
b. MAINTENANCE		a. DEFICIENCY	
X c. Data Analysis		b. SHORTCOMING	
		c. SUG. IMPROVEMENT	
		d. OTHER	
		26. ACTION TAKEN	
		a. REPLACED	
		b. REPAIRED	
		c. ADJUSTED	
		d. DISCONNECTED	
		e. REMOVED	
27. DATE AND HOUR OF INCIDENT 27 July 1972, 1300 (zone 2 firing)		X f. NONE	
IV. INCIDENT DESCRIPTION			
28. DESCRIBE INCIDENT FULLY This EPR supplements EPR KE-1, 24 July 1972, which reported a high malfunction rate (duds plus mine actions) at zone 1 firings from the M110, 8-inch howitzer and the M114A1, 155mm howitzer. On 27 July 1972, in accordance with the USAFABD test plan, the USAFABD fired the M110 8-inch and the M114A1 155mm howitzers at zone 2 in an attempt to isolate the zones and conditions under which malfunctions occur. The results of zone 2 firings and all firings to date are shown on the attached chart. The USAFABD has suspended testing of the M572E2 fuze in accordance with directions from HQ, TECOM.			
DEFICIENCIES AND SHORTCOMINGS ARE SUBJECT TO RECLASSIFICATION			
29. DEFECTIVE MATERIAL SENT TO: NA			
30. NAME, TITLE & TEL EXT OF PREPARER CLIFFORD J. EBY, MAJ, FA Project Officer 639-3231		31. FOR THE PRESIDENT:  HAROLD V. MADDEN COL, FA Chief, Test Division	

EPR KE-1-S1
 TECOM Project No 2-MU-007-572-012
 31 July 1972

WEAPON	ZONE	ROUNDS FIRED		NO OF MALFUNCTIONS		OBSERVED RELIABILITIES (%)	
		TEST ITEM	STD ITEM	TEST ITEM	STD ITEM	TEST ITEM	STD ITEM
M101A1	1	50	46	2	2	96.00	95.65
M101A1	7	34	39	0	0	100.00	100.00
M102	1	32	41	0	2	100.00	95.12
M102	7	69	42	1	1	98.55	97.62
M109	1	20	24	1	0	95.00	100.00
M109	7	40	50	2	1	95.00	98.00
M109A1	8	36	45	4	2	88.89	95.55
M110	1	83	56	19	2	77.11	96.43
M110	2	40	10	7	1	82.50	90.00
M110	7	50	44	1	1	98.00	97.73
M114A1	1	61	53	6	1	90.16	98.11
M114A1	2	40	8	5	0	87.50	100.00
M114A1	7	56	49	4	4	92.86	91.84
TOTALS		611	507	52	17	91.49	96.65

APPENDIX B
SUMMARY OF 1972 TESTS (ED, ET, & ST)
OF FUZE M572E2

**FUZE M572E2
1972 ED TEST SUMMARY**

(SQ Setting)

<u>Weapon</u>	<u>Model</u>	<u>Zone</u>	<u>Results</u>
4.2 inch	M30	5 inc	18/18
90 mm	Tank gun	Service	103/103
105 mm	M101	1	20/20
		5	3/3
		7	20/20
155 mm	M114/M1	1	449/452
175 mm	M107/M113	3	15/15
8 inch	M110	1	<u>15/15</u>
		Total	643/646
		Reliability	99.5%

**FUZE M572E2
1972 ED TEST SUMMARY**

(Delay Setting)

<u>Test</u>	<u>Weapon</u>	<u>Model</u>	<u>Zone</u>	<u>Results</u>
Plywood screen	90 mm	Tank gun	Service	20/20
Plywood screen	105 mm	M101 how.	1 7	8/9 62/62
Graze impact	105 mm	M101 how.	1 & 2	<u>29/30</u>
			Total Reliability	119/121 98.3%

**FUZE M572E2
1972 ET TEST SUMMARY**

(Safety Phase)

1. 40-foot drop test - satisfactory
2. Ballistic firings (set SQ)

<u>Weapon</u>	<u>Model/tube</u>	<u>Zone</u>	<u>Results</u>
105 mm	M102/M137	1	38/38
105 mm	M102/M137	7	224/230
105 mm	M101A1/M2A2	7	95/96
175 mm	M107/M113	3	<u>287/289</u>
Total Reliability			644/653 98.6%

3. "No test" firings*

105 mm	M102/M137	7	179/200
--------	-----------	---	---------

*Twenty-one duds reported. This test was fired over rough water with T2 spotting charges (no HE rounds). Doubt exists regarding these failures, since signatures and weather conditions may have caused observer's error. APG reported this portion as "No test."

**FUZE M572E2
1972 ET TEST SUMMARY**

(Reliability)

<u>Weapon</u>	<u>Model</u>	<u>Tube</u>	<u>Zone</u>	<u>Results</u>
105 mm	M102	M137	1	62/64
	M102	M137	7	57/58
4.2-in. mortar	M30		Incre 5 & 6	35/35
175 mm	M107	M113	3	<u>39/40</u>
			Total Reliability	193/197 97.9%

**FUZE M572E2
1972 ET TEST SUMMARY
(Arming and Sensitivity)**

Weapon

4.2-inch mortar, model M30

105 mm howitzer, model M102, tube M137

Target

Plywood

Sensitivity

<u>Weapon/zone</u>	<u>Mode</u>	<u>Mean thickness (inches)</u>	<u>Std deviation (inches)</u>
4.2/10	SQ	2.32	0.278
4.2/10	Delay	1.35	0.098
105/1	SQ	2.10	0.190
105/1	Delay	2.47	0.666

Arming

<u>Weapon/zone</u>	<u>Mode</u>	<u>Mean arming distance (ft)</u>	<u>Std deviation (ft)</u>
105/1	SQ	154.9	2.44
105/7	SQ	150.8	5.88

**FUZE M572E2
1972 SERVICE TEST SUMMARY***

Weapon, 105 mm howitzer

Model M101A1, tube No. M2A2
Model M102, tube No. M137

<u>Zone</u>	<u>SQ</u>	<u>Delay</u>	<u>Total</u>
1	48/48	34/34	82/82
7	<u>67/67</u>	<u>34/35</u>	<u>101/102</u>
Total	115/115	68/69	183/184

Reliability 99.4%

*Includes reverses. Three delay-set fuzes functioned in SQ mode.

**FUZE M572E2
1972 SERVICE TEST SUMMARY***

(155 mm howitzer)

<u>Howtizer</u>	<u>Zone</u>	<u>SQ</u>	<u>Delay</u>	<u>Total</u>
M114A1	1	38/41	17/20	55/61
	2	18/20	17/20	35/40
	7	35/35	18/20	53/55
M109	1	20/20		20/20
	7	19/20	19/20	38/40
M109A1	8	15/15	18/21	33/36
All models (Sub-totals)	1	58/61	17/20	75/81
	2	18/20	17/20	35/40
	7	54/55	37/40	91/95
	8	<u>15/15</u>	<u>18/21</u>	<u>33/36</u>
	Total	145/151	89/101	234/252

Reliability 92.8%

*Includes three reverses.

**FUZE M572E2
1972 SERVICE TEST SUMMARY**

(8-inch howitzer, model M110, tube M2A1E1)

<u>Zone</u>	<u>SQ</u>	<u>Delay</u>	<u>Total</u>
1	53/67	13/16	66/83
2	19/20	15/20	34/40
7	<u>18/18</u>	<u>31/32</u>	<u>49/50</u>
Total	90/105	59/68	149/173

Reliability 86.1%

APPENDIX C

1972 DIAGNOSTIC TEST REPORTS FOR FUZE M572E2

Firing Test: August 8-11 (1972) at APG

Conditions: 100 rounds fired in 8-inch howitzer model M110, zone 1.
Fuzes: Booster pellet was removed and replaced with wooden plug to expedite recovery. **Rounds:** Inert.

Included:

1. 50 with S&A setback pin and booster pellet removed.
2. 50 with only booster pellet removed.

Purpose: To determine if S&A setback pin is cause of failure.

Results: 100% functioning (no duds).

Conclusion: Previous cause of low-zone howitzer duds was not determined; therefore, the diagnostic tests must continue.

- Directions:**
1. Perform initial action tests referred to in Table 1.
 2. Ship 50 fuzes from Ft. Sill to APG for firings at latter site and, conversely, ship 50 fuzes from APG to Ft. Sill for firings at latter site in 8-inch weapons, zone 1.

Table 1
Outcome/action diagnostic tests

TEST RESULTS		CAUSE(S)	INITIAL ACTIONS
FT SILL	APG		
DUDS	DUDS	f,g	2
DUDS	NO DUDS	a,b,c,f	1
NO DUDS	DUDS	d,e	2, 3
NO DUDS	NO DUDS	u n k	RESUME ET/ST

- a) IMPACT AREA
b) WEAPON/RAMMING
c) HE ROUNDS
d) STORAGE
e) TRANSPORTATION & HANDLING
f) FUZE/ROUND INTERFACE
g) FUZE
- 1) FIRE FOR RECOVERY AT FT SILL AND/OR YUMA
2) DISASSEMBLE FUZES FROM FT SILL
3) FIRE FOR RECOVERY AT APG

Firing Test: Sep 5-14 (1972) at APG

Conditions: 50 rounds fired in 8-inch howitzer, zone 1. Ft. Sill fuzes shipped to APG.

Purpose: To determine if the APG and the Ft. Sill environments affect the fuzes and firings differently.

Results: Three duds out of 45 (42/45)

Four reversals

- Conclusions:**
1. Transfer of the Ft. Sill fuze lot to APG and the change of guns did not materially affect (improve) the dud rate.
 2. Softer soil at APG may be reason for smaller percentage of duds at APG (reference to Ft. Sill's hard soil).
 3. Confirms reports from Honeywell that both fuze lots were similar.

- Directions:**
1. Plan to recover the three live duds for X-ray and examination.
 2. Ship fuzes to Yuma for continued diagnostic testing at that site, since Ft. Sill indicated that they did not have the facilities nor was it their mission to perform diagnostic testing.

Firing Test: Sep 24-26 (1972) at APG

Conditions: 40 rounds fired in 8-inch howitzer, zone 1.

Ft. Sill fuzes shipped to APG.

Booster pellets replaced with wooden plugs (inert) and rounds inert.

Purpose: Simulate ST test conditions of Ft. Sill firings (except inert), recover and examine fuzes for any malfunctioning.

Results: 100% functioning (no duds).

Conclusions:

1. Previous causes of duds not fully determined.
2. The simulated inert booster in the fuze somehow affects or changes the conditions within the fuze, possibly the pressure on the S&A.

Directions: Continue diagnostic testing as follows:

1. Transfer entire diagnostic operation to Yuma.
2. Investigate reason for 100% functioning when booster pellet is removed and replaced by a wooden plug as in this test and test of Aug 8-11.

Recovery: Oct 2-7 (1972) at APG

Conditions: Recovered three live fuzes (duds) from live 8-inch projectiles fired during Sep 5-14 period at APG.

Purpose: To examine fuzes for cause of malfunctioning.

Results: Recovered fuzes showed the following:

1. S&A rotors were in fully safe position.
2. Auto delays had not prereleased.
3. S&A spin detents functioned as intended.
4. Cause of duds in the S&A module was considered to be one of the following:
 - a. Failure of gear train to start.
 - b. Failure of setback pin to retract.
 - c. Failure of setback pin to stay down.

Conclusion: The examination of these recovered fuzes, plus a spin test run by the contractor, indicated that the probable cause of the duds was the failure of the setback pin to stay down.

Directions: Repeat results of this test for confirmation, correct the S&A problem with a fix, and verify.

Firing Test: Oct 2-13 (1972) at Yuma

Conditions: 96 rounds fired in 8-inch howitzer, zone 1.

Ft. Sill fuzes shipped to Yuma.

Test Program:

1. 24 fuzes (live rounds) fired on hard soil.
2. 24 fuzes (live rounds) fired on soft soil.
3. 24 fuzes (inert rounds) with booster pellet replaced by wooden plug with 1/8-inch rubber disc on top, fired on hard soil.
4. 24 fuzes (inert rounds), with booster pellet replaced by wooden plug with 1/8-inch rubber disc on top, fired on soft soil.

- Purpose:
1. To determine if the booster pressure on the S&A or the assembly of the booster affects reliability.
 2. To determine if hard or soft targets affect reliability.

Results:

1. Live on hard soil.	14/24
2. Live on soft soil.	14/24
3. Inert on hard soil.	12/18
4. Inert on soft soil.	<u>18/20</u>
Total	58/86

- Conclusions:
1. Soil target conditions do not seem to affect reliability.
 2. Pressure on S&A does adversely affect reliability.
 3. X-ray examination of eight recovered duds showed that the S&A setback pin was re-engaged in the setback-pin hole, thus blocking the rotor before it had a chance to begin arming.

Directions: Continue this type of testing for verification.

Firing Test: Oct 29 - Nov 3 (1972) at Yuma

Conditions: 96 rounds fired in 8-inch howitzer, zone 1.

Fuzes were modified by removing various components, such as booster cup, setback pin, and spin locks; boosters were backed off 1/4 turn on all fuzes except as noted below.

Purpose: To determine if setback pin and/or excessive pressure by the booster on the S&A unit affected proper operation of the S&A.

Results:

1. 100% (24/24) functioned with setback pin removed and booster cup backed off 1/4 turn.
2. 21/24 functioned with booster cup removed, replaced, then backed off 1/4 turn.
3. 22/24 functioned when spin locks were removed and booster cup was backed off 1/4 turn.
4. 15/24 functioned when fuze was not modified in any way (original ET/ST design).

Conclusions:

1. Fuzes with setback pin removed functioned 100%.
2. Fuzes with booster cup backed off 1/4 turn showed some improvement over ET/ST lot.
3. Fuzes with no modification to the original ET/ST design still showed a high dud rate.

Directions: Plan to fire fuzes with booster cups backed off one full turn and with modified setback-pin cavity.

Firing Test: Nov 9-23 (1972) at Yuma

- Conditions:**
1. 97 rounds fired in 8-inch howitzer, zone 1.
 2. Fuzes were modified with three new and different S&A configurations in the setback pin and cavity area.
 3. Group 1 (as described below) were the original modifications as shipped to Yuma. This group contained configuration changes in the setback pin and cavity area; each change was an independent modification.
 - a. Smooth ramp angle of 55° instead of 40° in setback-pin cavity.
 - b. Stepped ramp angle of 55° in setback-pin cavity.
 - c. A polyurethane washer around the setback pin to delay its return.
 4. Since the fuzes in Group 1 failed with a high dud rate, testing was stopped. As a result, Group 2 modifications with different fixes were performed at Yuma. This group used fuzes with Group 1 modifications (3, above) as the basis with one of the following additional modifications:
 - a. Booster cup backed off 1/4 turn.
 - b. Setback pin removed.
 - c. Setback-pin cavity filled with Nyogel 843.
 - d. Felt washer and pad on each side of the S&A.
 5. Standard ET/ST fuzes were also tested with the added modifications described in paragraph 4, above.

- Purpose:** To determine which fixes resulted in the elimination of duds by allowing the rotor to move freely and completely to the armed position once the detents were spun out.
- Results:**
1. The complete results are tabulated in Table 2.
 2. 100% functioning occurred in fuzes in which:
 - a. The setback pin was removed (24/24), and
 - b. The setback pin cavity was filled with Nyogel 843 (14/14).
 3. Duds occurred in fuzes in which:
 - a. The booster cup was backed off 1/4 turn, and
 - b. A felt washer and pad were added on each side of the S&A.
- Conclusions:**
1. The three new S&A configurations in Group 1 did not eliminate or reduce the high dud rate.
 2. A high probability exists that the problem was in the setback pin and cavity area.
- Directions:**
1. Plan to test fuzes with other S&A setback pin and cavity configurations.
 2. Expand studies on the use of grease-filled cavities.

Table 2

Test results at Yuma, Nov 9-23, 1972*

		Modifications						Results
<u>55° smooth ramp</u>	<u>55° stepped ramp</u>	<u>Polyurethane washer around setback pin</u>	<u>Setback pin removed</u>	<u>Felt washer & pad on each side of S&A</u>	<u>Setback pin cavity filled with Nyogel 843</u>	<u>Booster backed off 1/4 turn & threads sealed with epoxy</u>		
X							3/8	
	X						3/8	
		X					2/8	
X			X				8/8	
	X		X				8/8	
			X				8/8	
				X			2/5	
X						X	4/8	
	X					X	4/8	
						X	6/8	
	X				X		8/8	
					X		6/6	
						X	1/6	

*All rounds fired in 8-inch howitzer, zone 1.

Firing Test: Nov 26 - Dec 8 (1972) at Yuma

- Conditions:
1. 64 rounds (total) fired in 8-inch howitzer, zone 1.
 2. Test Group A (S&A and PD module changes) - 24 fuzes with the following modifications:
 - a. The displacement travel distance (stroke) of the setback pin within the setback-pin cavity was increased from 0.078 inch to 0.150 inch (to delay the return of the setback pin).
 - b. The setback-pin length was decreased from 0.158 inch to 0.140 inch (to delay the return of the setback pin).
 - c. The retainer plate was removed and replaced by a double-backed aluminum tape of 0.045-inch thickness (to dampen the bounce of the setback pin).
 - d. The nose (PD) module was modified by redesigning the configuration at the junction of the rain head and the firing pin section by providing a chamfer cut instead of a right angle cut. This provides a more positive striking action of the rain head against the firing pin.
 - e. An M1 delay plunger was substituted for the auto delay.
 3. Test Group B (S&A module changes) - 24 fuzes with various changes in S&A modules, such as addition of spacer washer and aluminum tape, and changes in setback-pin stroke, length, and spring. (Refer to Table 3.)
 4. Test Group C (no piece-part modifications) - 16 fuzes.
 - a. Six fuzes with booster cups backed off $\frac{1}{2}$ turn.
 - b. Ten fuzes with no modifications.

Purpose: To evaluate various modifications to the S&A and PD modules.

Results: Refer to Table 3.

Conclusion: The four changes to the S&A and PD modules in test Group A gave 100% proper functioning and appear to have solved the low-zone dud and nose pinch-off problems.

Directions: Verify the successful modifications with additional tests and firings in the 8-inch howitzer, zone 1.

Table 3

Test results at Yuma, Nov 26 - Dec 8, 1972*

	S&A Modifications				Miscellaneous Modifications				Results				
	55° smooth ramp	20G spring	Spacer washer added	Aluminum tape added	Setback-pin stroke 0.135 in.	Setback-pin stroke 0.150 in.	Setback-pin length 0.140 in.	M1 delay plunger		Chamber cut (PD module)	Booster cup backed off 1/2 turn	No modif.	
X	X	X	X	X	X	X	X	X	X			24/24	
	X	X	X	X						X		3/6	
		X											11/12
			X	X							X		5/10
			X	X									10/12

*All rounds fired in 8-inch howitzer, zone 1.

Firing Test: Jan 29 - Feb 10 (1973) at Yuma

Conditions: 216 rounds with various modifications to fuze S&A, auto delay, and booster modules fired under various conditions as shown in Table 4.

Purpose:

1. To verify and evaluate fixes in the S&A module as a result of the successful firings during the period of Nov 26 to Dec 8, including the effect of a longer setback-pin stroke and the addition of double-backed tape.
2. To evaluate fixes to the auto delay module, including the addition of contoured detents and a leaf spring.
3. To evaluate other concepts of setback-pin design such as Honeywell air sac design, a double integrator, and an existing HDL design (to overcome deficiencies in S&A module).

Result: See Table 4.

Conclusions:

1. Greatly increasing the stroke of the setback pin to 0.236 inch resulted in improved reliability while the increase to 0.150 inch gave less reliable results.
2. Insertion of the leaf spring in the auto delay module resulted in 100% proper functioning.
3. Other modifications to the S&A (such as the Honeywell air sac design and the HDL XM587 design) or the auto delay modules resulted in unsatisfactory performance.

Directions: Plan to fire a larger sample of M572E2 fuzes consisting of the most effective modifications for verification.

Table 4

Test results at Yuma, Jan 29 - Feb 10, 1973

Weapon/zone	Impact area soil	S&A Modifications					Auto Delay Modifications				Booster Modifications		Result	
		Setback-pin stroke (in.)	Inboard stake	Double tape in setback-pin cavity	Setback pin removed	Double Integrator setback pin	Honeywell air sac	HDL setback design No. 1	Contoured detent	Graze balls removed	6-Prong leaf spring	M1 plunger		Backed off 1/2 turn
8-in. Z1	Soft	.150	X	X										16/20
8-in. Z1	Soft	-	X		X									19/20
8-in. Z1	Hard	.150	X	X										16/20
8-in. Z1	Hard	.150	X	X								X		8/10
8-in. Z1	Hard	.236	X											21/22
8-in. Z1	Soft	-				X					X			16/20
8-in. Z1	Hard	-					X				X			6/10
8-in. Z1	Hard	-						X			X			2/6
8-in. Z1 (inert)	Soft	.150	X											18/20
8-in. Z2	Hard	.150	X	X										18/20
155mm Z2	Hard	.150	X	X									X	10/10
105mm Z7	Hard	.150	X	X					X					8/12
105mm Z7	Hard	.150	X	X					X					2/6
105mm Z7	Hard	.150	X	X					X					20/20

Firing Test: Feb 23 (1973) at Yuma

Conditions: 40 fuzes fired in 8-inch howitzer, zone 1.

1. Test A: 20 fuzes (Lot PA-22) modified the same as test group A of the December 4 firing (during period of Nov 26 - Dec 8 at Yuma) which functioned 100%. These modifications included:
 - a. Three changes in setback pin and cavity area as outlined in December 4 firing with stroke of 0.150 inc' , pin length of 0.140 inch, and double-backed tape.
 - b. PD module with chamfer cut.
 - c. M1 delay plunger.
2. Test B: 20 fuzes (Lot PA-23) of the 1972 ET/ST design except for the following:
 - a. Setback pin from HDL XM587 fuze design with lockout feature.
 - b. M1 delay plunger.

Purpose:

1. To verify results of previous Yuma tests as outlined in conditions above.
2. To test a new setback-pin design.

Results:

Test A (Lot PA-22): 100% functioned 20/20

Test B (Lot PA-23): 100% functioned 20/20

Conclusions:

1. The model used in Test A now has a successful performance of 44/44.
2. The successful testing of the model in Test B demonstrates the need for a lockout feature for the S&A setback pin.

Directions: Verify with additional tests.

Firing Test: Mar 8 (1973) at Yuma

Conditions: 40 rounds fired in 8-inch howitzer, zone 1.

1. Lot PA-24: 20 fuzes containing S&A samples selected with minimum arming time (.933 - .960 sec) from PA-15 fuze lot, as used in test of 1/29 to 2/10 period which included:

a. PD module: chamfer cut.

b. M1 delay plunger.

c. S&A:

(1) Setback pin stroke - 0.150 inch.

(2) Setback pin length - 0.140 inch.

(3) Rotor stakes inboard.

2. Lot PA-25: 20 fuzes containing S&A samples selected with maximum arming time (.977 - 1.02 sec) from PA-15 fuze lot (same as above).

Purpose: To determine whether or not low and high S&A arming times have any effect on fuze function.

Results:

1. Lot PA-24 - min arming time - 17/20.
2. Lot PA-25 - max arming time - 18/20.
3. It was determined that the lubrication of all the S&A's used in this test was contaminated during production of the units and therefore may be the cause of duds.

Directions: Rerun test with uncontaminated S&A units.

Firing Test: Mar 23 (1973) at Yuma

Conditions: 48 rounds fired in 8-inch howitzer, zone 1 with all of the following fuze modifications:

1. S&A gear train lubricated.
2. S&A setback pin removed.

M1 delay plunger.

Purpose: To determine if the lubrication process required during production of the S&A units was performed satisfactorily and correctly. (Reference contaminated S&A lubrication of March 8th firings.)

Results: 100% function (48/48)

One reversal

Conclusion: Good control of the S&A lubrication process was re-established.

Directions: None

Firing Test: April 3-13 (1973) at Yuma

Conditions: 306 rounds fired in 4.2-inch, 105 mm, and 8-inch weapons. Fuzes with various modifications as shown in Table 5.

Purpose:

1. To fire fuzes consisting of modifications which successfully functioned (100%) during period of Jan 29 to Feb 10, for verification.
2. To fire fuzes with other modifications including the inclusion of a heavier setback pin made of tungsten.

Results: 100% functioning in all three weapons of fuzes with the following modifications (PA-34 model):

1. S&A setback pin made of tungsten.
2. Setback-pin stroke of 0.236 inch.
3. Auto delay with 6-prong leaf spring (Table 5).

Conclusion: The PA-34 model has given the best functioning performance to date in all three weapon/zone conditions of 4.2 inch, 105 mm, and 8 inch, fired for extreme conditions of spin, velocity, and acceleration.

Directions: Fire the PA-34 model under extreme conditions of temperature.

Table 5

Test results at Yuma, April 3-13, 1973

Lot No.	Weapon/zone	Mode	S&A Modifications						Miscellaneous Modifications				Results	
			0.236"		0.151"		Hi-G		Auto		M1			Results
			stroke steel setback pin	stroke tungsten setback pin	stroke steel setback pin	stroke steel setback pin	lockout setback pin	lockout setback pin	delay leaf spring	delay plunger				
PA-30	8-in. Z1	SQ	X						X				21/24	
PA-31	8-in. Z1	SQ			X				X				46/48	
	105 mm Z7 4.2-in.	delay			X				X				24/24	
PA-32	Incr 10	SQ			X				X				24/24	
	8-in. Z1	SQ						X	X				47/48	
PA-34	105 mm Z7	delay						X	X				22/24	
	8-in. Z1	SQ						X	X				48/48	
PA-38	105 mm Z7 4.2-in.	delay						X	X				24/24	
	Incr 10	SQ						X	X				24/24	
PA-38	8-in. Z1	SQ								X			20/20	

Firing Test: April 24-28 (1973) at Yuma

Conditions: 144 rounds fired in 8-inch howitzer, zone 1 with fuzes set SQ.

1. 48 fuzes (PA-40) - Modification consisting of an S&A with a steel setback pin and a stroke of 0.151 inch, and an auto delay with a 6-prong leaf spring.
2. 96 fuzes (PA-41) - Modification consisting of an S&A with a tungsten setback pin and a stroke of 0.236 inch, and an auto delay with a 6-prong leaf spring.

Purpose: To confirm results of previous successful test (Apr 3-13), but fired under extreme temperature conditions.

Results:

<u>This test</u>	Same design tested <u>previously</u>	<u>Ambient</u>	<u>+145°F</u>	<u>-50°F</u>
PA-40	PA-31 (Apr 3-13)	16/16	16/16	16/16
PA-41	PA-34 (Apr 3-13)	32/32	32/32*	32/32

*Two functioned delay due to reversals; one functioned delay due to missing SQ detonator.

Conclusions:

1. The PA-34/PA-41 has given the best overall results in both normal and extreme gun environment and temperature conditions.
2. The PA-34/PA-41 design configuration has been selected for the presuitability testing of fuze M572E2.

Directions:

144 additional fuzes of the final design (PA-34/PA-41) will be fired in other weapons and conditions (including delay setting) not fired previously, to assure that this new design will function properly in all weapons and conditions.

DISTRIBUTION LIST

	<u>Copy No.</u>
Commander Picatinny Arsenal ATTN: SARPA-AD-F	1
SARPA-AD-F-E-1, Mr. E. Entin, Bldg 62S	2-10
SARPA-AD-F-D	11-16
SARPA-TS-S	17-21
SARPA-QA-A-F, Bldg 62S	22-23
SARPA-QA-A-P, Mr. J. Domen, Bldg 94	24-25
Dover, NJ 07801	
Defense Documentation Center Cameron Station	26-27
Alexandria, VA 22314	
Commander US Army Materiel Development & Readiness Command ATTN: DRCDE-WC	28
Alexandria, VA 22304	
Commander US Army Armament Command ATTN: AMSAR-RDF	29-32
AMSAR-RDT	33
Rock Island, IL 61201	
Commander Frankford Arsenal ATTN: SARFA-MDA-E	34-35
Philadelphia, PA 19137	
Commander Harry Diamond Laboratories ATTN: AMXDO-DAB	36-37
Washington, DC 20438	

THIS REPORT HAS BEEN DELIMITED
AND CLEARED FOR PUBLIC RELEASE
UNDER DOD DIRECTIVE 5200.20 AND
NO RESTRICTIONS ARE IMPOSED UPON
ITS USE AND DISCLOSURE.

DISTRIBUTION STATEMENT A

APPROVED FOR PUBLIC RELEASE;
DISTRIBUTION UNLIMITED.