

UNCLASSIFIED

AD NUMBER

ADB012785

LIMITATION CHANGES

TO:

Approved for public release; distribution is unlimited.

FROM:

Distribution authorized to U.S. Gov't. agencies only; Test and Evaluation; JUN 1976. Other requests shall be referred to Air Force Rome Air Development Center, IRRO, Griffiss AFB, NY 13441.

AUTHORITY

radc, usaf ltr, 26 sep 1980

THIS PAGE IS UNCLASSIFIED

**THIS REPORT HAS BEEN DELIMITED
AND CLEARED FOR PUBLIC RELEASE
UNDER DOD DIRECTIVE 5200.20 AND
NO RESTRICTIONS ARE IMPOSED UPON
ITS USE AND DISCLOSURE.**

DISTRIBUTION STATEMENT A

**APPROVED FOR PUBLIC RELEASE;
DISTRIBUTION UNLIMITED.**

RADC-TR-76-185
Final Technical Report
June 1976



2

AD B 01 2785

TERMINAL ANALYSIS STUDY

Harris Corporation

Distribution limited to U. S. Gov't agencies only;
test and evaluation; June 1976. Other requests for
this document must be referred to RADC (IRRO),
Griffiss AFB NY 13441.

ROME AIR DEVELOPMENT CENTER
AIR FORCE SYSTEMS COMMAND
GRIFFISS AIR FORCE BASE, NEW YORK 13441

AD No. _____
DDC FILE COPY

DDC
RECEIVED
AUG 13 1976
B

This report has been reviewed and is approved for publication.

APPROVED:

David R. Boyle

DAVID R. BOYLE, Capt, USAF
Project Engineer

APPROVED:

Howard Davis

HOWARD DAVIS
Technical Director
Intelligence and Reconnaissance Division

FOR THE COMMANDER:

John P. Huss

JOHN P. HUSS
Acting Chief, Plans Office

ACCESSION for	
NTIS	White Section <input type="checkbox"/>
DDC	Buff Section <input checked="" type="checkbox"/>
UNANNOUNCED	<input type="checkbox"/>
JUSTIFICATION.....	
BY.....	
DISTRIBUTION/AVAILABILITY CODES	
Dist.	Avail. and/or SPECIAL
B	

Do not return this copy. Retain or destroy.

UNCLASSIFIED

SECURITY CLASSIFICATION OF THIS PAGE (When Data Entered)

REPORT DOCUMENTATION PAGE		READ INSTRUCTIONS BEFORE COMPLETING FORM	
1. REPORT NUMBER RADC-TR-76-185	2. GOVT ACCESSION NO.	3. RECIPIENT'S CATALOG NUMBER	
4. TITLE (and Subtitle)	5. TYPE OF REPORT & PERIOD COVERED Final Technical Report Aug - Dec 1975		6. PERFORMING ORG. REPORT NUMBER N/A
7. AUTHOR(s) Gary/Hoffman Al/Martin	8. CONTRACT OR GRANT NUMBER(s)		9. SECURITY CLASS. (of this report) UNCLASSIFIED
10. PERFORMING ORGANIZATION NAME AND ADDRESS Harris Corporation Electronics Systems Division P O Box 37, Melbourne FL 32901	11. PROGRAM ELEMENT, PROJECT, TASK AREA & WORK UNIT NUMBERS 62702F 45941019 AT-4594		12. REPORT DATE Jun 76
13. CONTROLLING OFFICE NAME AND ADDRESS Rome Air Development Center (IRRO) Griffiss AFB NY 13441	14. MONITORING AGENCY NAME & ADDRESS (if different from Controlling Office) Same		15. NUMBER OF PAGES 117
16. DISTRIBUTION STATEMENT (of this Report) Distribution limited to U.S. Gov't agencies only; test and evaluation; June 1976. Other requests for this document must be referred to RADC (IRRO), Griffiss AFB NY 13441.			17. SECURITY CLASS. (of this report) UNCLASSIFIED
17. DISTRIBUTION STATEMENT (of the abstract entered in Block 20, if different from Report) Same			18. DECLASSIFICATION/DOWNGRADING SCHEDULE N/A
18. SUPPLEMENTARY NOTES RADC Project Engineer: Capt David R. Boyle/IRRO			
19. KEY WORDS (Continue on reverse side if necessary and identify by block number) Imagery Transmission Image Scanning and Reproducing Data Compression Facsimile Image Processing			
20. ABSTRACT (Continue on reverse side if necessary and identify by block number) This final report summarizes the results of a study performed for analysis and definition of image terminals and configurations required to meet anticipated Department of Defense image transmission requirements. The report reviews the basic study requirements and system constraints and contains a brief review of some system considerations for image terminal interaction and throughput. It is shown that some form of data compression is required to achieve the desired throughput. The specific recorder/scanner candidates include laser-galvanometer			

DD FORM 1 JAN 75 1473 EDITION OF 1 NOV 65 IS OBSOLETE

UNCLASSIFIED
SECURITY CLASSIFICATION OF THIS PAGE (When Data Entered)

408 972

UNCLASSIFIED

SECURITY CLASSIFICATION OF THIS PAGE(When Data Entered)

cathode ray tube, drum and laser beam types. It is concluded that terminal configurations should be based on drum and laser-galvanometer recorder/scanner technology, depending upon the type of imagery which is to be processed by the terminal. The main features and performance parameters of four terminal types are briefly described. The terminal configurations are comprised of modular components which, beginning with the least complex version, can be upgraded by adding higher performance recorder/scanners and more processing capability. Advanced development projects are recommended to be performed in conjunction with the program and a summary of cost estimates for several potential network implementation scenarios is provided. The final section is an appendix which discusses the current and anticipated military communications environment in Europe.

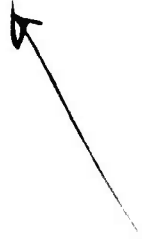

UNCLASSIFIED

SECURITY CLASSIFICATION OF THIS PAGE(When Data Entered)

TABLE OF CONTENTS

<u>Paragraph</u>	<u>Title</u>	<u>Page</u>
1.0	INTRODUCTION	2
2.0	REQUIREMENTS AND SYSTEM CONSTRAINTS	4
2.1	System Definitions and Assumptions	4
2.2	Terminal Interaction	9
2.3	Throughput Considerations	13
3.0	TECHNICAL EVALUATION	18
3.1	Image Recording and Scanning	18
3.1.1	Image Quality Factors	19
3.1.2	Speed Considerations	25
3.1.3	Scan Density Selection	34
3.1.4	Recording Media Considerations	37
3.2	Recorder/Scanner Candidates	43
3.2.1	Laser-Galvanometer Recorder/Scanner	43
3.2.2	Cathode Ray Tube (CRT) Recorder/Scanner	46
3.2.3	Drum Recorder/Scanners	47
3.2.4	Laser Beam Recorder/Scanners	50
3.2.5	Terminal Recorder/Scanner Recommendations	52
3.3	Terminal Input and Output Consideration	53
3.3.1	Operational Concepts	53
3.3.2	Store and Forward Operation	55
3.4	Terminal Intercompatibility	59
3.5	Terminal Modularity	63
3.6	Security Considerations	66
3.7	Communication Interface Considerations	68
3.8	Data Compression	70
3.9	Data Processing Options	75
4.0	TERMINAL CONFIGURATIONS	82
4.1	The "D" Terminal	82
4.2	The "D _{RO} " Terminal	85
4.3	The "C" Terminal	85
4.4	The "B" Terminal	88

TABLE OF CONTENTS (Continued)

<u>Paragraph</u>	<u>Title</u>	<u>Page</u>
5.0	PROGRAM CONSIDERATIONS	92
5.1	Technical Considerations	92
5.2	Cost and Schedule Considerations	94
	Appendix A1	97

LIST OF ILLUSTRATIONS

<u>Figure</u>	<u>Title</u>	<u>Page</u>
2.1	Image Quality and Terminal Operating Ranges for Scan Density . .	6
2.2	General Block Diagram of Terminal	9
2.3	Image Transmission Setup	11
2.4	Image Throughput Versus Link Bit Rate For Link Limited Operation (No Overhead)	14
2.5	Throughput Versus Link Range As A Function of Step-Coding Reduction	16
3.1	Image Spatial Frequency and MTF	20
3.2	Image Scanning Input/Output Responses	22
3.3	Recorder/Scanner Scan Rate Versus Scan Density	26
3.4	Film Transport Limitations	29
3.5	Laser-Galvanometer and CRT Performance Limitation	30
3.6	Drum and LBR Performance Limitations	32
3.7	Scan Density Selection Options	35
3.8	Application Range for Recording Data	40
3.9	Recorder Laser Power Requirements	42
3.10	Laser-Galvanometer Recorder/Scanner Components	44
3.11	Improved Laser-Galvanometer Implementation	45
3.12	Acausto-Optically Controlled Down Recorder/Scanner	49
3.13	Terminal Automation Options	54
3.14	Terminal Multidrop Arrangement	60
3.15	Basic Data Processing Function Diagram	64
3.16	EICS and Laserfax TEMPEST Tests	66
3.17	Terminal Interface Through MIL-STD-188C	68
3.18	REARCS and Zoom Capability	73
3.19	General Data Processing Trade-Offs	77
3.20	Data Compression Processing Limitations	78
4.1	"D" Terminal Block Diagram	83
4.2	"D" Terminal Artist's Conception	83
4.3	"DRO" Terminal Block Diagram	86
4.4	"C" Terminal Block Diagram	86
4.5	"B" Terminal Artist's Conception	87
4.6	"B" Terminal Block Diagram	88
4.7	"B" Terminal for Photointerpretable Imagery Over High-Speed Communication Links	89

LIST OF TABLES

<u>Table</u>	<u>Title</u>	<u>Page</u>
3.1	Recorder/Scanner Cost Dependent Factors	52
3.2	Level Change Statistics and Coding	71
3.3	MOS and Bipolar Microprocessor Comparison	76
5.1	First Unit Costs (\$000)	95
5.2	Unit Costs in Lots of Ten (\$000)	95
5.3	Program Costs (\$000)	96
A1	European AUTOVON Sites	99
A2	European AUTODIN Sites	100
A3	European AUTOSEVOCOM AN/FTC-31 Switch Sites	100
A4	Transmission Facilities - Europe	102

SECTION 1.0

INTRODUCTION

1.0 INTRODUCTION

This final report summarizes the results of a study performed for Rome Air Development Center by HARRIS Electronic Systems Division (Harris ESD) for analysis and definition of image terminals and configurations required to meet anticipated Department of Defense requirements. The report is divided into four major sections and an Appendix. Section 2.0 reviews the basic study requirements and system constraints and contains a brief review of some system considerations for image terminal interaction and throughput. It is shown that some form of data compression is required to achieve the desired throughput. Section 3.0 is the major technical section in which evaluation of various technologies, equipment, and operability conditions is performed. The specific recorder/scanner candidates include laser-galvanometer, cathode ray tube, drum and laser beam types. It is concluded that terminal configurations should be based on drum and laser-galvanometer recorder/scanner technology, depending upon the type of imagery which is to be processed by the terminal. Section 4.0 briefly describes the main features and performance parameters of four terminal types. The terminal configurations are comprised of modular components which, beginning with the least complex version, can be upgraded by adding higher performance recorder/scanners and more processing capability. Section 5.0 describes advanced development projects which are recommended to be performed in conjunction with the program and also summarizes the cost estimates for several potential network implementation scenarios. The final section is an appendix which discusses the current and anticipated military communications environment in Europe.

SECTION 2.0
REQUIREMENTS AND SYSTEM CONSTRAINTS

2.0 REQUIREMENTS AND SYSTEM CONSTRAINTS

2.1 System Definitions and Assumptions

The primary technical requirement of this study is to produce general specifications, operational analyses and cost data for several different image terminals. The image terminals, which are points of interface with an imagery transmission system, are devices used for the receipt and/or transmission of electrically transmitted imagery. The four different types of terminals evaluated are classified according to their ability to receive and/or transmit a range of image scanning densities. The "B" terminal has the capability of transmitting and receiving images with the highest resolution, i.e., with scanning density of 2000 lines/inch and lower. The "C" terminal receives and transmits imagery at scanning densities of between 800 and 1000 lines/inch and lower. The "D" terminal receives and transmits between 300 and 500 lines/inch and lower whereas the "E" terminal, which we will refer to hereafter as the D_{RO} ("D" Read Only) terminal, receives 300 to 500 lines/inch and lower imagery. For purposes of this study, it is assumed that imagery received from, or transmitted to, terminals with a scan density lower than 300 to 500 lines per inch will be consistent with the operating parameters of the Tactical Digital Facsimile (TDF) equipment.

Four image quality groups have been defined so that a generalized image quality performance characteristic can be identified and associated with an image product.

- Low Readability (LR): A level of image quality that is suitable for briefing aids and similar products as defined by individual users. This quality level, chosen to be less than 3 line pairs per millimeter, is established to provide a quality descriptor for transmitted materials which can fulfill an operational requirement even at this relatively low resolution. Briefing quality materials would be suitable for transmission by a system which operates at less than 220 lines per inch.

- Medium Readability (MR): An image quality range of 3-6 line pairs per millimeter viewed at a distance of 18 inches with average lighting and contrast (physiological limit of the average eye). An image of quality greater than medium readability could be optically magnified to obtain more information. An image of less than medium readability quality, if optically magnified, would not provide additional information. This quality is resolvable by a scanning system operating between 220 and 430 lines per inch.
- High Readability (HR): An image quality range of 6-20 lines per millimeter. This quality is resolvable by a scanning system operating at 430 to 1400 lines per inch.
- PI Quality: PI quality is defined as an image quality range varying from the upper bound of the "High Readability Quality" range to the quality of the sensing system that created the original image. Actual transmitted qualities may vary throughout this range depending upon format and magnification factors; however, the information content of the sensing system shall be retained as closely as possible.

Figure 2.1 compares the terminal scan density range with the image quality ranges defined above. A terminal of a given scan density range also includes the ability to receive and/or transmit at lower scan densities.

Evaluation Factors

Factors used as a basis for technical evaluation of the terminal are summarized below:

- Resolution: A factor which covers a broad range from about 3-30 cycles per millimeter. The principle aim of the study is to configure the terminal to provide a capability for transmitting all types of imagery and graphics at the minimum acceptable quality level to assure the most timely dissemination of the product.

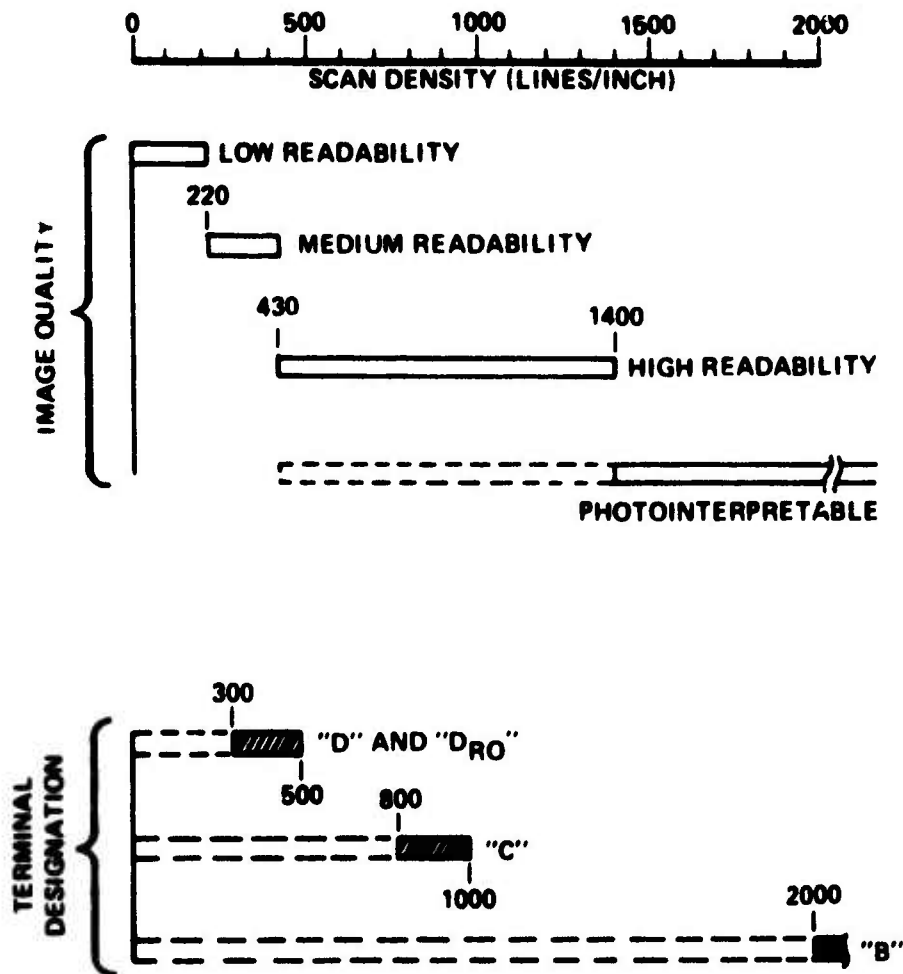

Figure 2.1. Image Quality and Terminal Operating Ranges for Scan Density

- Shades of Grey: A Factor Expressed in Bits Per Pixel - The upper limit for the number of grey shades discerned and reproduced by the equipment is specified at 6 bits/pixel or 64 shades per pixel in all areas of the image that are not degraded by data reduction schemes. For document transmission only two shades of grey are considered.
- Data Compression/Reduction: The baseline approach uses the Redundant Area Coding (REARC) scheme which has produced data reductions on the order of 20:1 and greater on the Experimental Image Compression System (EICS). The REARC concept is explained in Paragraph 3.3.

- Input/Output Factors: Each terminal will be capable of recording and scanning opaque or transparent material and be able to record positive or negative images. The maximum image format size is 9 inches by 13 inches. Terminals "B" and "C" shall have the capability to scan selective portions within this format.
- Recording Media: Both silver halide film and dry silver paper and film should be considered as options.
- Automatic Operation: Automated operation of the terminal should be considered to the maximum practicable extent without compromising reliability or producing inordinately complex or costly implementation.
- Digital Interface and Temporary Storage: A factor which permits digital input to the system processor and bulk storage of digitized imagery for a store and forward mode of operation.
- Security: A factor which assures that the terminal is compatible with existing communications security (COMSEC) equipment and meets all applicable TEMPEST requirements.
- Militarization: A factor to which consideration shall be given for ruggedization of the equipment. Most terminals are assumed to be installed in office type environments. Field deployable terminals may be used in tactical shelters and other transportable military containers. The cost impact of full military specification ruggedization is to be determined.
- Intercompatibility: A factor which requires that each terminal type be able to communicate with any other terminal. Scale and format changes should be considered.
- Modularity: A factor which requires that the terminals be configured for easy upgrading to higher capability by adding either improved or additional modules.

- Communications interface: A factor requiring easy interface to a variety of communication links including wire line, microwave, tropospheric scatter and/or satellite communications.
- Data Rate: A factor which applies to the communication network and the internal terminal data rate. The terminal's, scanning, digitizing, and recording rate should not be the limiting factor affecting transmission time for data rates up to 32 kb/s, including data compression. The "B" terminal will be configured to supply data at 1.5 mb/s but, in this case only, without data compression.
- Broadcast Mode: A factor which requires certain terminals to simultaneously transmit to more than one terminal.
- Maintenance: Terminals are to be configured for easy maintainability by field service personnel.
- Data Processing: Several data processing techniques will be examined and, if appropriate, the hardware will be selected from a list of standard DOD processors.

Although the factors listed above are adequate to perform a top level evaluation of the terminal performance, a detailed in-depth evaluation required information on communication loading and time-critical demands which were not available during the course of the study effort. Consequently, the conclusions reached and the resulting recommendations are based on certain assumptions, most of which are taken as worst-case situations. The effect of these assumptions may be to place more severe constraints on the hardware than is actually required. For example, it has been assumed that the average data rate which must be sustained by all terminals is equivalent to operating over a 32 kb/s link with data compression factors up to 20X. This produces an average data rate of 640 kb/s with instantaneous rates several times higher, thereby placing greater demands on the processing and recording equipment than may be actually required. The price for greater capability is usually higher cost. Detailed examination of all system aspects will be required to determine if the conclusions reached in this study are consistent with anticipated terminal usage.

2.2 Terminal Interaction

The image terminals which are evaluated in this report are configured on the basis of certain assumptions regarding the method which may be used to initiate, maintain, and modify transmission of the image. The terminal is assumed to be connected to a fixed rate communication link; the bit rate over the link being determined by a local oscillator located at the transmission site. A block diagram of the general terminal components is shown in Figure 2.2. The general steps for transmitting one scan line of data to a recorder are identified below.

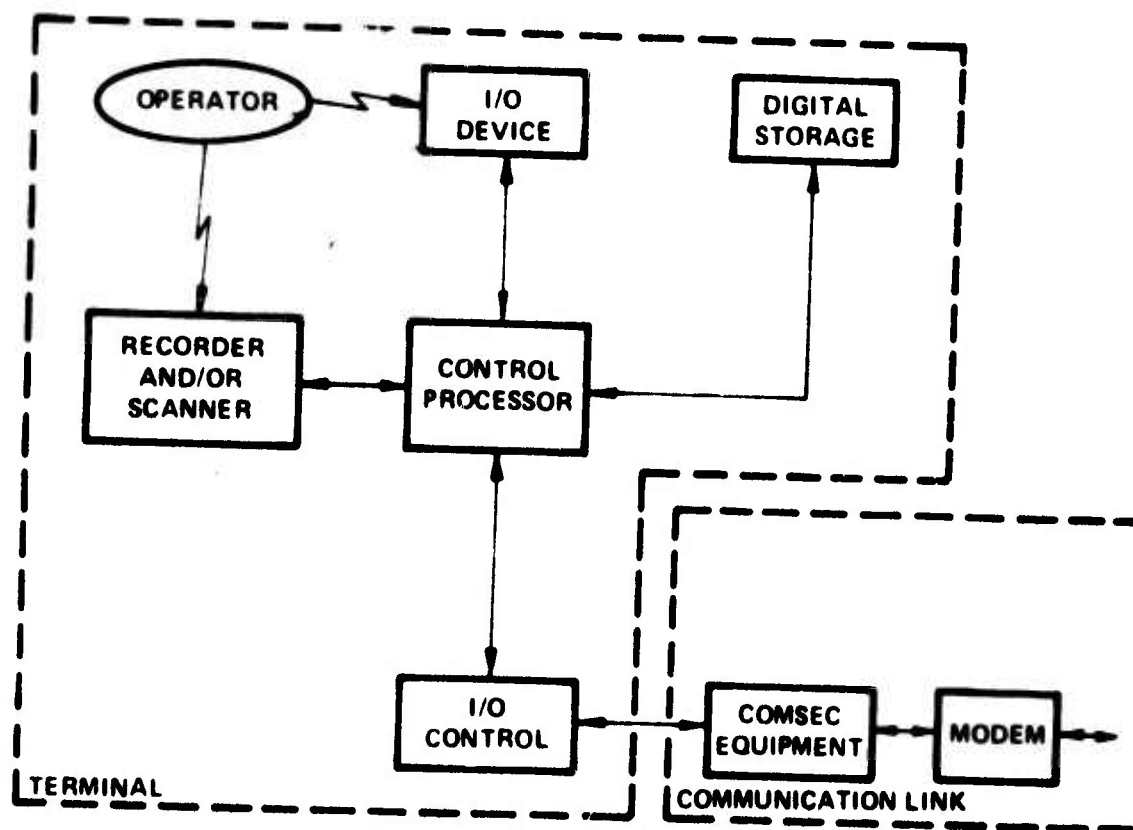

Figure 2.2. General Block Diagram of Terminal

- The terminal data processor commands the scanner to scan a line, encodes the data in an output buffer from which data is clocked at link bit rate to the COMSEC equipment.
- The COMSEC equipment encrypts the encoded data and passes the encrypted data to the modem if the transmission is to be made over an analog link.
- The modem converts the digital data into a form which is suitable for transmission over the analog link. For a digital link, the encrypted data is connected directly to the link.
- The encrypted data is transmitted over the link and reconverted to its original encrypted digital form, if required, at the receiver.
- The digital data is transmitted through the COMSEC equipment which converts it to the form of the original encoded data.
- The data is decoded and placed into an output buffer one line at a time by the data processor in the receiving terminal.
- The image recorder is commanded to step one line when the output buffer is full.
- The output buffer is emptied by transferring its contents to the image recorder which exposes one line of imagery.

Transmission is started by synchronizing the COMSEC equipment. When the transmitter is manually commanded to transmit, four setup words, such as shown in Figure 2.3, are transmitted at 512 bit intervals. The receiver detects the sync code and compares adjacent words until two are found that are identical. This multiple setup word transmission is used to reduce the probability of either missing the start of picture or obtaining the wrong setup data when burst errors are encountered. The setup information includes the scan density at which the data is to be transmitted, areas of the picture which are to be step coded, the number of bits into which the density function is quantized, and a flag bit identifying that the coding has been bypassed for this transmission. The data

processor in the receiver uses this information to select which recorder type (if more than one option is available) is to be used and to select the line and pixel deletion or repetition ratio. The receiving terminal would normally produce images with the same scale factor as on the original. The receiving terminal alters the recording resolution to maintain the same scale factor; manual intervention is required to effect a scale change.

SYNC 32 bits	Transmitter 2 bits	Redundant area select 117 bits	Quantized 1 bit	REARCS Coding Bypassed 1 bit
-----------------	-----------------------	--------------------------------------	--------------------	---------------------------------

Transmitter Setup Data Frame

- Transmitted 4 times at intervals of 512 bits
- Two adjacent frames must be received which compare at receiver for acceptance
- Elements are:

Sync	a fixed Barker word sync to allow detection of start of message by receiver.
Transmitter	Identifies transmitting terminal scan density.
Redundant Area Select	Identifies in unitary code by 1-inch square areas the redundant area.
Quantized	Identifies the level of quantization of the transmitted data.
Coding Bypass	Identifies the following message as being REARCS coded or not.

Figure 2.3. Image Transmission Setup

On completion of transmission of the last setup word, the transmitter sends three consecutive 30-bit sync words which identify the start of data. The 30-bit sync word is transmitted once more with no intervening interval to identify start of the first

data block. If the data of this first line contains both step and Huffman coded data, the 30-bit sync word is inverted and repeated once again. The data is broken every 256 samples for the insertion of 11-bit step coding parity check word or a 13-bit parity word for Huffman coding. End of line code is not provided. For the situation where the scanner or data processor cannot provide data at a rate which is fast enough to fill the link, fill bits are inserted until the next line is ready. Each line has the 30-bit sync pattern repeated once for lines which contain single codes or twice, with inversion of the second repetition, for lines which have mixed codes. The first line of each 1-inch block of copy is preceded by two consecutive transmissions of the complement of the 30-bit sync pattern. The end of picture is signalled by a repetition of three consecutive 30-bit sync patterns. After a delay of 512 bits, the end of picture message is repeated.

The receiver accepts the decrypted data and identifies the start-of-picture code. The data which follows is decoded and checked for parity error. Upon completion of the decoding operation, the line of data is transferred from the output buffer to the recorder. At the same time, a second buffer is being filled as the data from the new line is decoded. When the first buffer is empty, the recorder is commanded to step to the next line and is then ready to record data from the second buffer. Pixel deletion, repetition and line deletion is handled by the data processor before data is stored in the output buffer. Line repetition is implemented by reading the buffer several times before switching to the next buffer.

Manual inputs are required to define scan resolution, tolerance for step code, bypass condition, redundant areas and quantization. Scale change is achieved by manual intervention of both transmitter and receiver operating personnel. Manual override at the receiver may be used to cause the recorder to produce an image with a two, four or eight times expansion of scale as indicated below:

<u>Source Terminal</u>	<u>Receiving Terminal</u>	<u>Scale Change</u>
"B"	Any	1, 2, 4, 8
"C"	Any	1, 2, 4
"D"	Any	1, 2

Thus, the "B" terminal may obtain an 8X magnification of a subelement of the frame by transmitting at say 1600 and recording at say 200 lpi.

2.3 Throughput Considerations

The number of bits required to represent a scanned and digitized picture, with no coding overhead or data reduction, is given by:

$$N = H W Q S_H S_W$$

where N is the total number of bits

H is the image height

W is the image width

Q is the quantization level

S_H is scan density in the image height direction

S_W is the pixel density in the image width direction

For this discussion, S_H and S_W are assumed to be equal and will be referred to as S.

Consequently, the expression for bit capacity is

$$N = H W Q S^2$$

The number of images which can be transmitted per unit time is referred to as the system throughput. Expressed in terms of images per hour, the throughput is given by:

$$T = \frac{3600 L}{N} = \frac{3600 L}{H W Q S^2}$$

where L is link bit rate in bits per second.

The S^2 factor nonlinearly limits throughput. Doubling the sample density doubles the resolution of the reconstructed picture, but reduces the number of pictures which may be transmitted per unit time by a factor of four.

The throughput rate (in pictures per hour) for various link bit rates, quantizations, and image sizes are shown in Figure 2.4. Note that only 0.45 - 9 inches x 9 inches images per hour can be transmitted over a 9.6 kb/s link when sampled at 400 lines and samples per inch and quantized to 6 bits. A minimum of 2 hours and

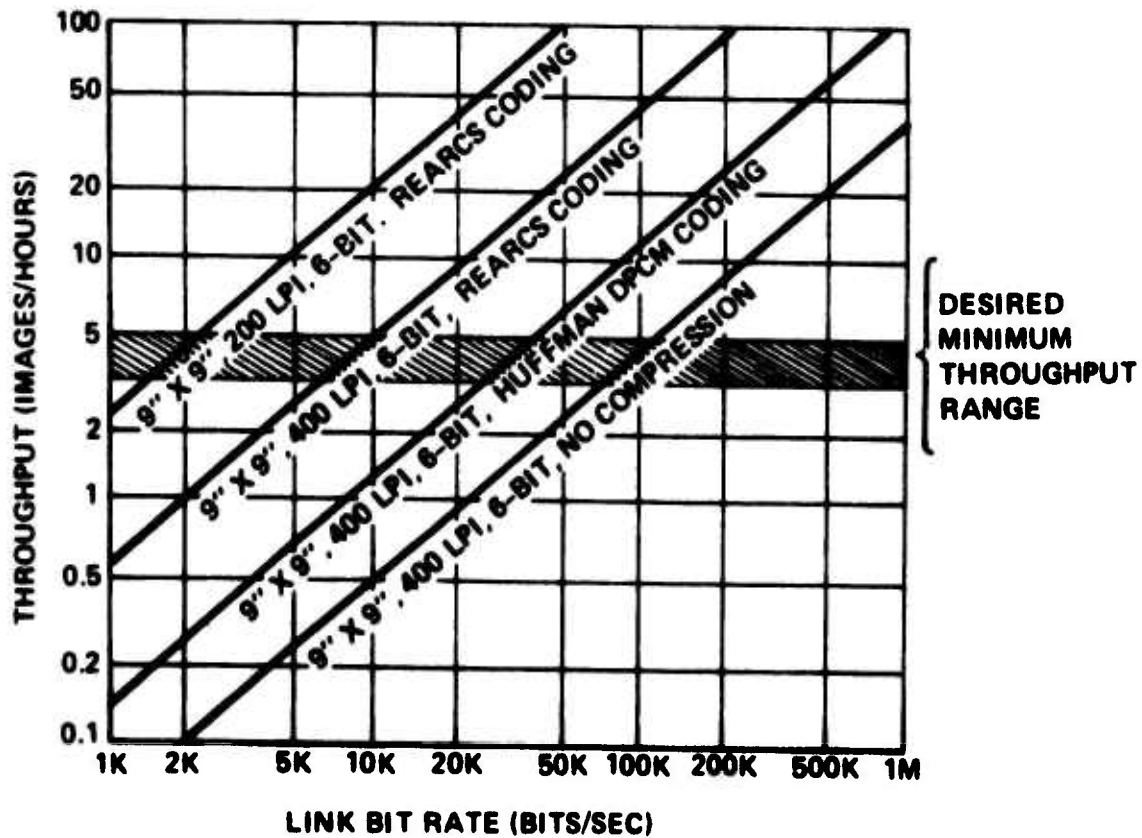

Figure 2.4. Image Throughput Versus Link Bit Rate For Link Limited Operation (No Overhead)

13 minutes would be required to transmit a single image. Using

only Huffman DPCM coding on this image increases the average throughput to 1.1 images per hour while a typical (10:1 compression) application of REARCS increases it further to 4.5 images per hour.

It should be remembered that the amount of data compression which can be achieved with any type of compression technique is not a constant but depends on many factors. The actual amount of data compression is a function of:

- image size
- the size of the redundant area
- the quantization levels in the redundant and nonredundant areas
- the line and pixel deletion ratio in the redundant area
- the tolerance assignments in the step-coded region
- spatial and temporal scanning spot intensity distribution
- the density distribution in the image

The effect of these factors is to cause the amount of data reduction to appear as a random variable. The amount of data reduction using a REARCS approach varies from 0.55 to 282 with a mean value of 10 to 12 for most grey shade imagery. The amount of data reduction using only a Huffman encoded DPCM approach varies from 0.46 to 6 with a mean value of about 3. These estimates do not, however, include the normal system overhead bits but refer only to data associated with the image. Figure 2.5 shows the range over which image throughput may be affected by different step-coding reduction ratios. The image is assumed to be a 9 inch x 13 inch image scanned at 400 lpi and quantized to 6 bits per sample.

NOTES:

9" x 9" IMAGE
400 LPI SCAN DENSITY
400 SAMPLES/INCH SAMPLING DENSITY
6-BIT QUANTIZATION

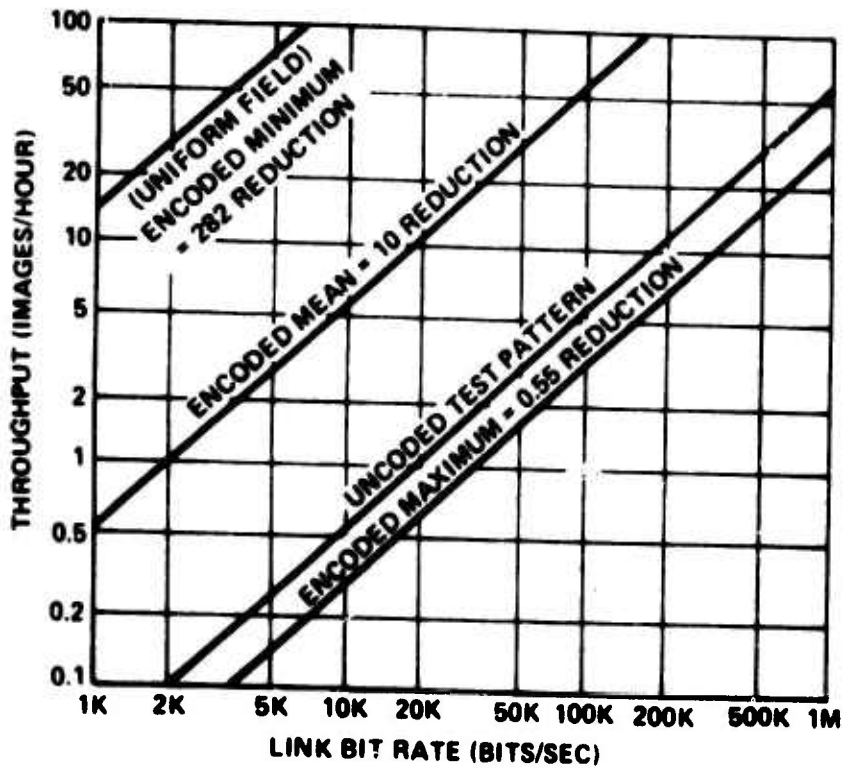

Figure 2.5. Throughput Versus Link Rate As A Function of Step-Coding Reduction

SECTION 3.0
TECHNICAL EVALUATION

3.0 TECHNICAL EVALUATION

In this section, the technical requirements are evaluated in terms of current and projected technology. In all cases, the emphasis has been placed on technology which has been either proven in field service or which could be well developed and reliable by the FY80 time frame. The frame of reference for evaluation is comprised of the system definitions and assumptions summarized in Paragraph 2.1 above.

The primary emphasis in this section is the evaluation of technology and technical approaches which will meet the image scanning, transmission and recording requirements for the Theatre Dissemination System. Specifically, several image recording/scanning techniques and associated input/output media are addressed in terms of their applicability and cost-effectiveness. The role of the data processing function is discussed along with the effect of processing speed on the selection of specific implementation approaches. Although the primary discussion focuses on the image producing hardware, it is also of use to evaluate the terminal technology in terms of key operability and functional parameters such as intercompatibility and modularity. The evaluation of technical factors leads to a general list of top-level terminal specifications which are discussed in Section 4.0.

3.1 Image Recording and Scanning

This section reviews some of the basic concepts associated with image transmission and examines the factors which limit the full exploitation of current image producing technology. A complete examination of component technology associated with image recording and scanning is beyond the scope of this study. Rather, the examination is confined to technology or devices which in some way restricts or bounds the performance of various recording and scanning equipment designs.

3.1.1 Image Quality Factors

Many factors must be considered for a thorough evaluation of image quality and a total discussion of this topic is clearly beyond the scope of this study. It is instructive, however, to examine a few of the key image quality factors and terms and to relate these to the somewhat arbitrary image quality ranges defined in Paragraph 2.1. The four major characteristics of grey scale photographic imagery which enter into a description of image quality are: 1) average density, 2) geometric fidelity, 3) resolution, and 4) contrast.

The first two factors are easily quantified in objective terms and will not be discussed in detail here. Average density refers to the average brightness of the image and is controlled by adjusting the overall exposure level and by selecting proper recording media which will support the average and extreme values of exposure. It has been shown that the eye has a limited range of average density which it perceives as an appealing scene. Geometric fidelity refers to the absolute and relative location of any point in the image. An image with high geometric fidelity corresponds very closely with the geometry of the original object. For scanning systems, high scan density usually correlates with high geometric fidelity. The recording and scanning factors which primarily determine the degree of geometric fidelity are scale factor and two-dimensional scanning linearity.

Resolution and contrast are considered together because they are interdependent; i.e., visual resolution is dependent upon the contrast. This relationship is expressed in terms of the Modulation (contrast) Transfer Function (MTF) which is defined as the contrast in the image produced by a sinusoidal intensity distribution in the object plane. This number is a function of the spatial frequency, i.e., the number of cycles per unit length of the sinusoidal object. Figure 3.1 shows a graphical representation of the input object target and the image. The graphical representation of a typical MTF curve is shown in Figure 3.1 (c).

It should be noted that MTF is only strictly defined for sinusoidal objects and linear systems. Frequently this restriction is violated which then requires careful

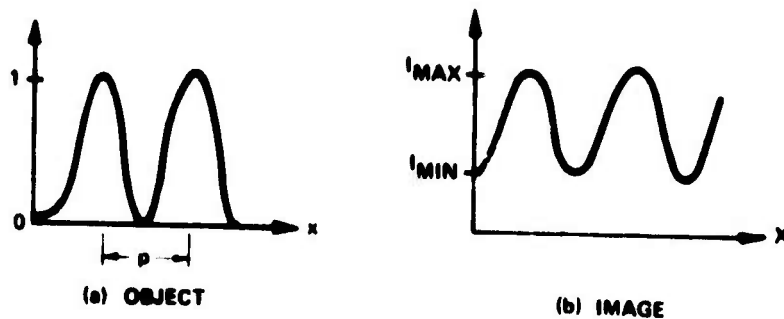

SPATIAL FREQUENCY $\nu = 1/p$ (CYCLES PER UNIT DISTANCE)

$$MTF(\nu) = \frac{I_{MAX}(\nu) - I_{MIN}(\nu)}{I_{MAX}(\nu) + I_{MIN}(\nu)}$$

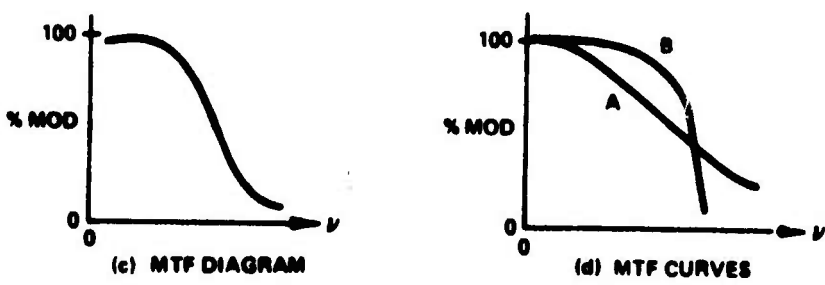

Figure 3.1. Image Spatial Frequency and MTF

interpretation of "MTF" response. Despite this limitation, the concept of MTF can be quite useful. The sinusoidal limitation is really not a limitation at all, since any object can be represented as a linear combination of sinusoidal signals by Fourier composition. Much additional information can be gained if the curve is examined in its entirety. Consider, for example, the two curves plotted in Figure 3.1 (d). Although curve A represents a system with higher resolution than system B, the image from system B would appear "sharper" and, therefore, better to most observers. This is because the eye responds primarily to spatial frequencies in the lower range where the MTF is greater in system B.

In scanning systems where the recording material is usually nonlinear, a system MTF is not rigorously defined; however, it is possible to specify the resulting modulation on the output as a function of spatial frequency, even though this number is not linearly related to the input function. Consequently, general classification ranges such as the readability criteria used in this study may be useful guides which can be used to correlate with measured performance values.

There is usually some confusion about the relationship between MTF, line scan density, spot size, etc. This can be made clear by understanding how scan line density and spot size affect the MTF curve. In general, the MTF of a scanning system is dependent upon the scan direction: the along-scan and across-scan MTF are, in general, only loosely coupled. For the along-scan direction, spot size and modulation bandwidth are the major factors which affect MTF. It can be shown that the MTF in this direction is given by the Fourier transform of the spot intensity distribution multiplied by the modulation bandwidth (spatial frequency bandwidth) of the spot. For a given scanning system, this MTF curve can be calculated exactly. In the specific case of a Gaussian spot intensity profile, the Fourier transform of the spot is also Gaussian and this, multiplied by the modulation bandwidth, is the system MTF. The along-scan MTF is therefore given by:

$$\begin{aligned} \text{MTF}_{A/S} &= B(f) \exp \left[-(\pi v d_o / 2\sqrt{2}(10^3))^2 \right]^2 \\ &= B(Vv) \exp \left[-v^2 d_o^2 / 1.23 (10^{-6}) \right] \end{aligned}$$

where

- v = spatial frequency in cycles/mm
- d_o = spot diameter in micrometers
- $B(f)$ = system electrical response in Hz
- V = scanning spot velocity in mm/s
- f = electrical frequency in Hz

In the cross scan direction the situation is more complex. The complexity arises from the fact that the "resolution" depends upon the relative alignment of the

object with respect to the scanned line. In Figure 3.2 (a) we show a square-wave object signal which is oriented as shown and is to be scanned with a spot which we assume has a

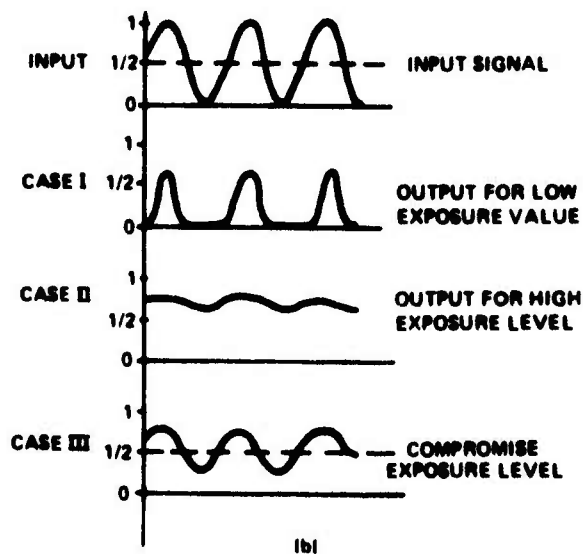
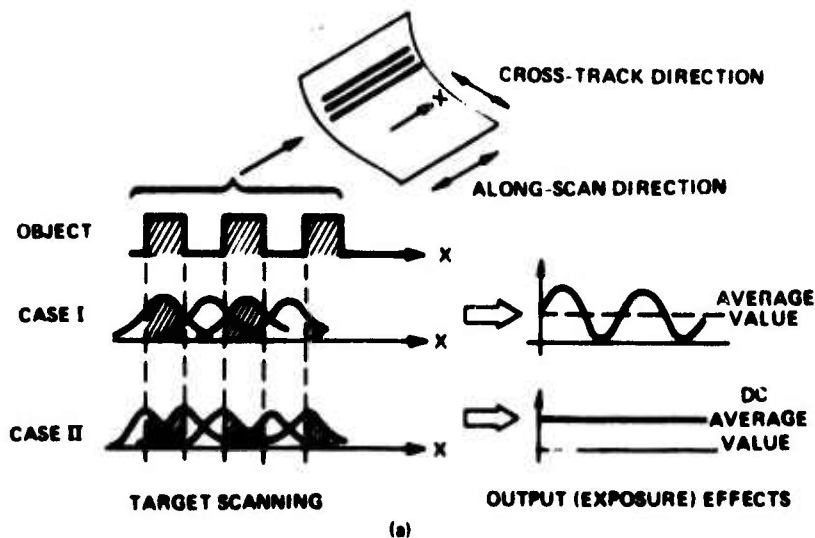

Figure 3.2. Image Scanning Input/Output Responses

Gaussian intensity profile in the cross-track direction. In Case I, the scan lines exactly coincide with the square-wave object period, thus, resulting in a strong cross modulation signal. In Case II, the same situation occurs except that the location of the scanning center line is shifted by one-quarter of the object period. Each spot intercepts the same

average area of the square-wave object resulting in no net modulation in the cross-track direction. In between these two extremes are a continuous range of solutions, all of which might be contained in any one image transmission. It is this dependence of the resolution on phase of the scan structure that causes the familiar banding or moire effect common to line scan imaging systems.

There is, however, a commonly used technique which eliminates this effect at the expense of resolution. In the previous example, one should recognize that the maximum resolution (in cycles/mm) is equal to one-half the scan density (in lines/mm). If as in Case 1 of Figure 3.2 (a) the spot size is increased so that the modulation is zero, then the modulation will always be zero at that frequency, thus, eliminating the problem. Of course, there is some residual effect for lower spatial frequencies, but once the scan line density is about four times the spatial frequency of interest, the phase dependence has been averaged out. The penalty for this is reduced resolution. The ratio of the actual resolution to the maximum resolution (1/2 scan line density) is historically known as the Kell factor. For Gaussian spot intensities the optimum Kell factor has been calculated to be $1/\sqrt{2}$ or 0.707. In practice the value ranges from about 0.65 to 0.75.

The cross-scan MTF for Gaussian profile scanning systems is similar in form to the expression previously given for along-scan MTF. It is given by:

$$\begin{aligned} \text{MTF}_{C/S} &= \exp \left\{ - \left[\pi u p K / 2\sqrt{2} (10^3) \right]^2 \right\} \\ &= \exp \left[- (upK)^2 / 1.23 (10^{-6}) \right] \end{aligned}$$

where

p = scan line density in mm and

K = Kell factor

and is valid only for Kell factors which are less than 0.75. One should note that larger spots also reduce the MTF in the along-scan direction. In some cases the spot is purposely elongated to form an elliptical scanning spot but this generally leads to performance in which horizontal and vertical resolutions are unequal.

Up to this point, only linear systems have been considered, however, most recording materials exhibit nonlinear behavior. While rigorous analyses of these effects are possible, it is perhaps more instructive to look at what happens to a linear MTF when it undergoes a nonlinear transformation. Film nonlinearities cannot increase the system MTF: at best they leave it unchanged. This can be illustrated by considering what happens to the modulation at different exposure levels as depicted in Figure 3.2 (b). For low exposure (Case I), the exposure of the peak regions have been sacrificed to obtain better definition in the low signal area. For a high exposure level (Case II) the opposite effect occurs. In between these two examples is an exposure which is a compromise such as shown in Case III. In many cases a means for purposely distorting or linearizing exposure values is implemented to produce image enhancement.

Producing uniform grey fields may cause a different set of problems. As previously explained, the Kell factor tends to smooth scan structure in the output image which, assuming no other errors, would tend to produce a uniform grey field for unmodulated input signals. For imaging from a digital source one has another potential source of error called quantization noise. If the recording material has a useful dynamic range of 30 grey shades and 5 bit (32 steps) encoding is chosen, a nearly uniform grey area may show structure due to the uncertainty in the least significant bit. This effect, called false contouring, is common to all digital systems, but it is particularly distracting in imagery work because of the human eye's ability to discriminate between two adjacent areas of slightly different density. False contouring is minimized by using the maximum grey shade capability of the system - in this study we assume that 6-bit quantization is used, thereby minimizing the effects.

We have up to now been concerned primarily with the equipment used to produce the image. In addition to many of the controlled nonlinear equipment effects, the recording and scanned media also produces nonlinear effects. Careful attention must be placed on the effects of dynamic range, substrate type, image tone and granularity. The dynamic range is the maximum to minimum range of densities that can be supported by the material. For most imagery work, the greater the dynamic range, the better. Substrate type is important in high quality imagery applications because it is not

uncommon for the substrate (film base or paper) to be of poorer surface quality than the actual photosensitive emulsion. This is particularly true for paper base materials where the fiber structure of the paper degrades the imagery. Image tone refers to the subjective "color" of the black areas on the material. Some are indeed black, while others may be brown or dark blue. The subjective image quality depends somewhat on this tone, with black being generally preferred. The last parameter, granularity, refers to the actual grain structure of photographic emulsions. Similar in effect to paper fiber structure, these grains may degrade the image but this is usually apparent only under high magnification.

In summary, many factors must be considered when analyzing and predicting performance of image transmission equipment. The MTF concept is the most commonly used measure of system "resolution" but for detailed evaluation, the effects of nonlinear factors must be assessed. Concepts such as we have discussed in this section must be used to accurately define and specify equipment and materials in detailed design exercises. To avoid a complicated specification of image quality, it is common to group classes of imagery into categories which bear some general relationship to the degree of image legibility or "readability." In Paragraph 2.1 we defined four readability groups which will be used only to aid us in our analyses of various terminal configurations.

3.1.2 Speed Considerations

The evaluation of image recording and scanning techniques requires an understanding of the speed limitations which are imposed by the selection of specific devices or subassemblies. The specification which determines the instantaneous operating speed of the recorder/scanner is that the terminal scanning, digitizing and recording rate not be limited by equipment considerations when operating over a 32 kb/s link with data reduction. It is also desirable to configure the terminal such that PI quality information can be transmitted over 1.5 Mb/s links without data compression.

The primary factor which limits the operating speed of most image recorder/scanners is mechanical inertia. This is particularly true for asynchronous recorder/scanners which operate by on-demand signaling for data recording and line advance. In

the most general case, such equipments operate with a triggered asynchronous line sweeping mechanism, e.g., CRT sweep or galvanometer, and an asynchronous line advance mechanism such as a stepped film transport. Obviously, a variety of methods could be used to overcome these limitations but they generally involve either more data buffering capacity or more costly and complex mechanisms to compensate for the mechanism shortcomings.

The operating speed of recording and scanning technology cannot be evaluated without also considering the scanning density of the image to be transmitted. Figure 3.3 displays operating speed on the ordinate axis in terms of scan lines per second

FIGURE NOTES:

IMAGE SIZE - 9" X 9"
 QUANTIZATION - 6 BITS/SAMPLE
 DUTY CYCLE - 80%

CURVE A - 32 KB/SEC (20:1 COMPRESSION)
 CURVE B - 1.5 MB/SEC (NO COMPRESSION)
 CURVE C - 1.5 MB/SEC (5.5:1 COMPRESSION)

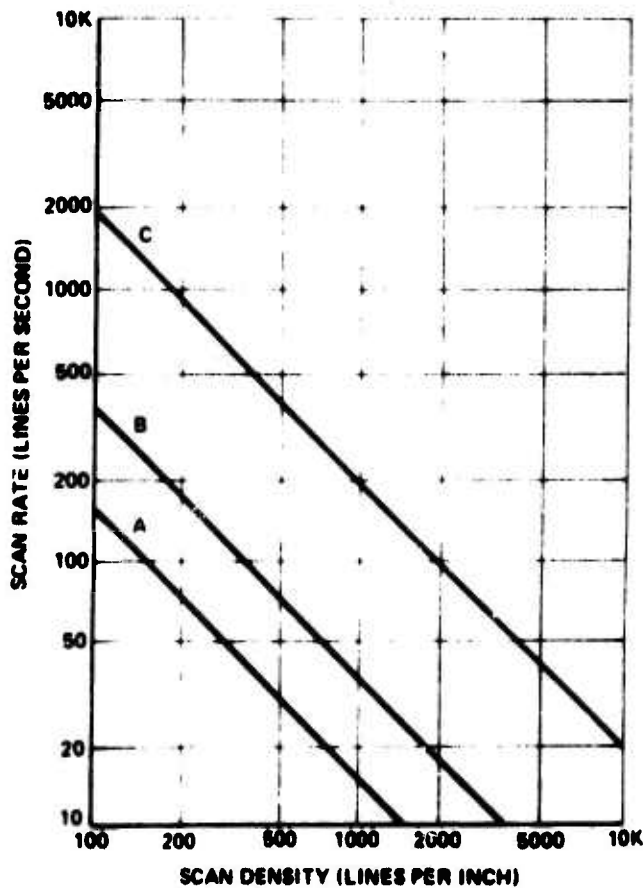

Figure 3.3. Recorder/Scanner Scan Rate Versus Scan Density

and scan density on the abscissa in pixels per inch. A "standard frame" measuring 9 inches by 9 inches and containing 64 grey shades per pixel has been used. In order

to arrive at some value for limitations to be placed on the scanning and transport mechanisms, a somewhat arbitrary 80 percent duty cycle has been assigned to the recording/scanning process. This factor is included to account for all types of processing inefficiencies including scanner flyback time (duty cycle effects), line and frame synchronization, and all other types of overhead. The diagonal lines on the graph represent the three data rates which we used to evaluate equipment performance limitations. The equation used to plot the diagonal lines in Figure 3.3 is:

$$R = \frac{LC}{(0.8)(6)(9)S} \approx 0.023 \frac{LC}{S} \frac{\text{lines}}{s}$$

where

R is the scan rate in lines/s

S is the scan density in lines/inch

C is the data compression factor and

L is the data rate in b/s

Three link parameters are shown on the figure which is of interest in this study. The lower line is the one of primary interest and represents a link operating at a data rate of 32 kb/s with an average of 20:1 data compression on the image. (Note that lower data compression values such as 10 or 12 to one would produce a line even lower on the graph.) The middle line represents a data link operating at 1.5 Mb/s without data compression. The top line is the same 1.5 Mb/s wideband link but operating with a 5.5:1 data compression factor.

It is instructive to overlay various image recording/scanning mechanisms on this chart to determine if the technology can support the link requirements. Specifically, we consider the limitations imposed by film transport mechanisms, galvanometer scanning mirrors, drum and carriage recorders and finally the high performance recorders generally referred to as "laser beam recorders" (LBR). The limits chosen for each technology should not be considered as absolute values but rather as an attempt to set some practical limits on the technology. In most cases, the limits which were set can be exceeded by either more sophisticated design approaches or by adding complexity (and cost) to the data

processing function. Consequently, the boundaries established should be considered "soft" rather than "hard" and used as a guideline for pointing toward technology which is most appropriate for the terminal requirements.

The first technology which is of interest is that associated with the movement of the recording medium by means of a transport mechanism. The two primary considerations are the precision and the step-and-settle time associated with the asynchronous advance mechanism. It is assumed that a transport of this type would be used with a cathode-ray tube, laser-galvanometer or high speed multifaceted mirror laser beam recorder. Experience indicates that 9-inch wide film can be moved reliably and repeatably by pulsed stepping motors and appropriate gear mechanisms at rates between 100 and 200 lines per second or between 5 and 10 milliseconds for stepping and settling. The precision with which film can be stepped, assuming the use of a capstan prime mover and recording on the capstan, is compatible with a scan density of about 2000 lines per inch. This implies a placement accuracy which is some fraction of the 0.5 mil line separation distance. Figure 3.4 shows the two limits imposed by stepped mode film transport technology. As discussed in Paragraph 3.1.3, scan densities between 400 and 2000 lines per inch for the three terminal configurations are of primary concern. Between these bounds, current film transport technology will support the primary link requirements of 32 kb/s with 20:1 data compression and 1.5 Mb/s without data compression. At higher system data rates (such as the upper curve of Figure 3.4), the film transport technology is able to support the link rate only at scan densities of between 1000 and 2000 lines/inch. But even in this region, the technology is being pushed to near practical limits. To avoid operation near the edge of this technology requires a detailed trade-off analysis of the cost of extra buffering, synchronous film motion or alternative optical scanning techniques which is beyond both the requirements and scope of this study.

Figure 3.5 shows the limitations of current recording and scanning technology which uses a laser as the light source in conjunction with a scanning mirror driven by a moving coil galvanometer. This technology has been recently developed for military applications in the Tactical Digital Facsimile (TDF) and for commercial applications such as the Harris Laserfax and Associated Press Laserphoto equipment. This

FIGURE NOTES:

IMAGE SIZE - 9" X 9"
QUANTIZATION - 6 BITS/SAMPLE
DUTY CYCLE - 80%

CURVE A - 32 kB/SEC (20:1 COMPRESSION)
CURVE B - 1.5 MB/SEC (NO COMPRESSION)
CURVE C - 1.5 MB/SEC (5.5:1 COMPRESSION)

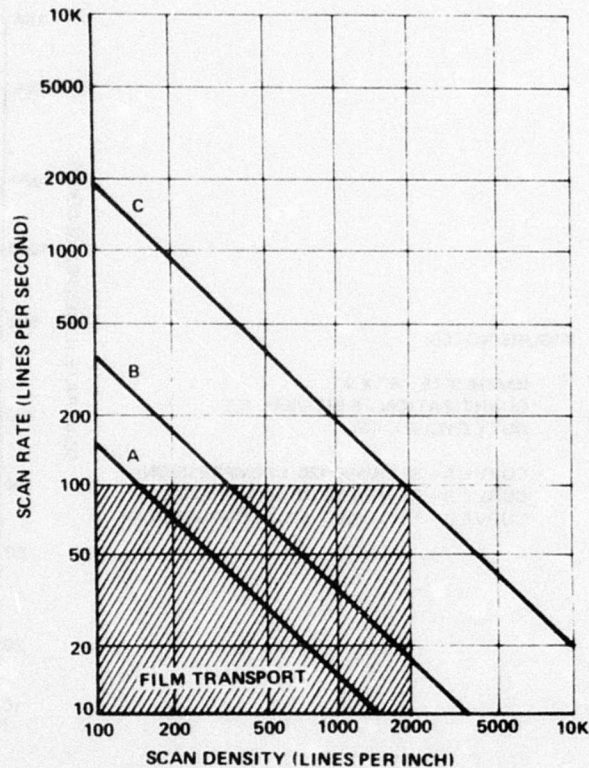

Figure 3.4. Film Transport Limitations

equipment commonly operates with 3M dry silver paper and film which is discussed in Paragraph 3.1.4. Experience with this type of equipment indicates that performance is limited in both dimensions by galvanometer constraints. To some extent speed limit and scan density limit are interdependent. The upper bound on galvanometer speed is set at about 50 scan lines per second for mirror sizes which are large enough to support medium readability imagery. The value of 50 scans per second assumes that a unidirectional scan is used and that about two milliseconds are used for retrace and settling. An approach using bidirectional scanning could improve the scan rate by a factor of two, but such an approach complicates the data buffering and adds timing complexity by requiring line-to-line phasing synchronization signals. The primary limitation on precision appears to be along-scan and cross-scan jitter of the galvanometer scanner. This limitation is set

FIGURE NOTES:

IMAGE SIZE - 9" X 9"
 QUANTIZATION - 6 BITS/SAMPLE
 DUTY CYCLE - 80%

CURVE A - 32 kB/SEC (20:1 COMPRESSION)
 CURVE B - 1.5 MB/SEC (NO COMPRESSION)
 CURVE C - 1.5 MB/SEC (5.5:1 COMPRESSION)

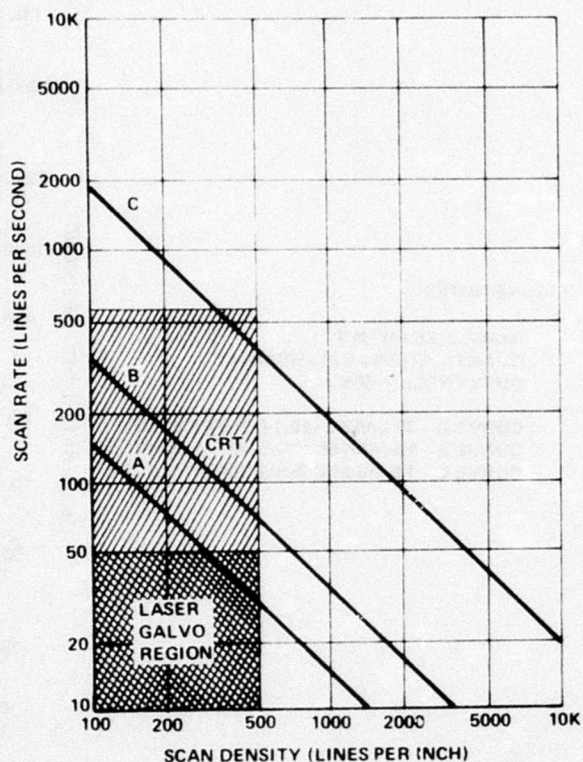

Figure 3.5. Laser-Galvanometer and CRT Performance Limitation

at about 500 scan lines per inch with selected galvanometers. The result of these two limitations relegates the basic laser-galvanometer approach to a region containing medium readability imagery. In low readability applications (say at 200 lpi), the speed limitation of the galvanometer scanner precludes filling a 32 kb/s link at 20:1 data compression.

Although the inherent limitations of the galvanometer restrict its current usage to medium readability imagery, evidence indicates that the scan density limitation can be at least doubled by using supplementary optics to compensate for mechanical uncertainties. In the along-scan direction, a precision ruling to clock data out from the buffer on the basis of laser beam position could be used rather than galvo signal. In the

cross direction, minor cross track corrections could be made using standard acousto-optical beam deflectors. Obviously, such an approach adds complexity and cost to a basically low cost device but it should be considered for future laser-galvanometer investigation and extends operation into the HR region. At 400 lines per inch, the scanning speed required is well within the physical limitation of the galvanometer so that a 32 kb/s link can be filled at 20:1 compression.

The cathode-ray tube has been used as a standard image recording device for many years and will continue to provide adequate performance in limited areas for the foreseeable future. However, it appears that during the next 5 years, CRT technology will give way to laser scanning techniques. In terms of resolution, the CRT is limited to the medium and high readability groups. Although scan density on the CRT faceplate can be increased by image demagnifications, this method is generally limited by the finite time-bandwidth product of the CRT. Although new phosphor deposition techniques may improve CRT image quality, only marginal gains may be anticipated. Experience with several CRT image recorders indicates an upper limit for reliable trouble-free operation of somewhat in excess of 5000 pixels across the tube face which, for a 9 inch image, corresponds to about 600 pixels per inch. This places the CRT resolution limit at the low end of the high readability group. The speed limitation for CRT recorders is a somewhat complicated function which is dependent upon the recording medium, the brightness of the CRT trace and the optical speed of the imaging optics. The actual sweep speed of the CRT trace, typically measured in microseconds per line, far exceeds the inherent scanning limitations of a laser-galvanometer approach for identical scan density. Figure 3.5 shows the limitation for CRT performance.

A drum recorder/scanner approach is significantly different from the technology discussed previously. In place of moving film, a fixed recording frame attached to a rotating drum is exposed by physically moving a light source carriage along the length of the drum. Although a drum recorder/scanner generally offers some definite cost/performance advantages, it may require a compromise in operational flexibility. Some methods for overcoming these constraints are indicated in Paragraph 3.2.3. Figure 3.6 shows the speed and resolution limitation for standard drum recorder/scanner

FIGURE NOTES:

IMAGE SIZE - 9" X 9"
 QUANTIZATION - 6 BITS/SAMPLE
 DUTY CYCLE - 80%

CURVE A - 32 kB/SEC (20:1 COMPRESSION)
 CURVE B - 1.5 MB/SEC (NO COMPRESSION)
 CURVE C - 1.5 MB/SEC (5.5:1 COMPRESSION)

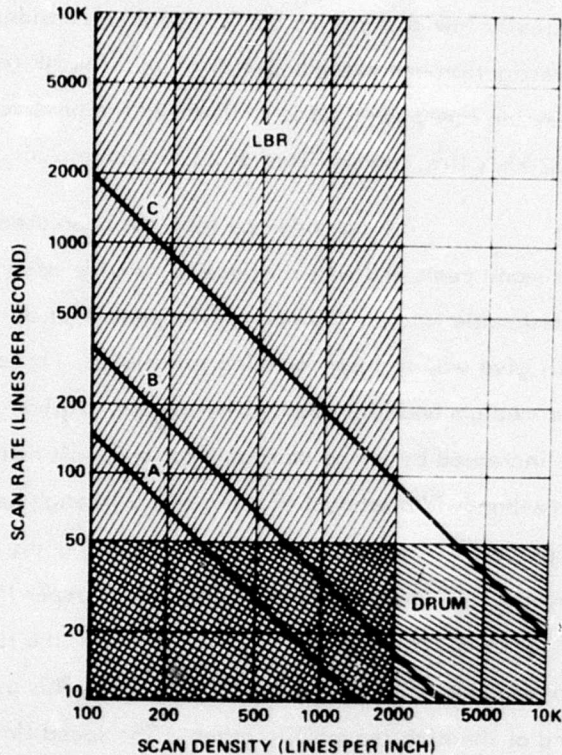

Figure 3.6. Drum and LBR Performance Limitations

implementation. The resolution limit for a drum recorder/scanner is determined primarily by the precision with which the mechanical components (e.g., lead screws, drum surface, bearings) are fabricated and assembled. Resolution well up into the photointerpretable region and approaching 10,000 scan lines are possible using the best technology available. For purposes of this study, it is clear that achieving 2000 scan line per inch resolution is easily realizable for drum recorder/scanner technology. The speed limitation for drum recorder/scanner technology is determined by two factors: the speed with which the recording carriage can be stepped to the next line and the rotation rate of the drum. The centrifugal force on the film is a function of the square of the drum rotation rate which, at high speed, may require unusual techniques to keep the film on

the drum surface. Although means are available for circumventing these problems, an upper limit for drum rotation rate at 6,000 r/min for a 9 inch circumference will be set, which corresponds to 100 scan lines per second. Step and settle times associated with the carriage are put at between 5 and 10 milliseconds which results in a total scan rate limitation of typically 50 scan lines per second. These values are plotted in Figure 3.6 and show that both the 32 kb/s and 1.5 Mb/s links can be filled using drum recorder technology. The most severe speed constraint would occur for a medium readability drum recorder/scanner operating at 400 scan lines per inch. A lower rotation and stepping rate is required for PI quality (2000 scan lines per inch) operating over a 1.5 Mb/s link without compression than is required for MR imagery.

The high performance recording devices commonly referred to as laser beam recorders generally consist of a laser, high-speed multi-faceted mirror spinner beam deflector, focussing optics and a means for moving the recording medium. Two different approaches are commonly used to implement the laser beam recorder: one which uses a complex lens to produce 20,000 or more well resolved spots on a flat field platen (capstan), and another which uses less complex optical componentry and records on a curved platen. Resolution of these recorders is determined by optical and mechanical components which can be readily configured to achieve 2000 scan line/inch PI quality and greater. The speed of the multifaceted mirror spinner is determined by the precision of the assembly. Speeds of 10,000 scan lines per second have been achieved in both ground and airborne recorders. The speed limitation of these recorders, assuming asynchronous operation, is determined by the film transport mechanism.

The speed and resolution limitations of the laser beam recorder are plotted in Figure 3.6. This technology, which is expensive, clearly meets all of the link requirements including the desire to support a 1.5 Mb/s link with 5.5:1 data reduction. Laser beam recording technology is the most suitable technology only for applications which require both high performance and high speed and where cost considerations are less important than quality and image throughput.

3.1.3 Scan Density Selection

In this section we examine several ways in which the scan density (lines per inch) may be selected to meet the terminal readability and compatibility requirements. The scan density ranges for readability groups and terminal configurations are:

Low Readability	Less than 220 scan lines per inch
Medium Readability	220 to 430 scan lines per inch
High Readability	430 to 1400 scan lines per inch
Photo Interpretable	More than 1400 scan lines per inch
"B" Terminal	2000 scan lines per inch and lower
"C" Terminal	800-1000 scan lines per inch and lower
"D" Terminal	300-500 scan lines per inch and lower

In addition, an unstated requirement exists to be compatible with TDF equipment which operates at scanning densities of 100, 150, and 200 lines per inch; thereby satisfying the requirement for handling low readability imagery.

The criteria used for selection of appropriate scan densities are highlighted below:

- Operate at a scan density of at least 2000 lines per inch when recording or scanning PI quality imagery.
- Select scan densities for the terminal equipment which are related by factors of two. This approach facilitates compatibility between terminals. By selecting the scan densities as integral multiples of the next lowest scan density, the functions required of the data processing module for magnification or demagnification are simplified. An image scanned at a low scan density can be reproduced on a higher scan density reproducer by repeating each sample the correct number of times and repeating the resulting line the same number of times. This maintains a unity scale factor between the original and the reproduction.

- Minimize the number of different scan densities required to meet the terminal readability requirements. A single scan density for each readability range will be considered to be adequate.

Figure 3.7 shows the scan density selections for two of the most likely options. The first option is derived by using the highest scan density requirement

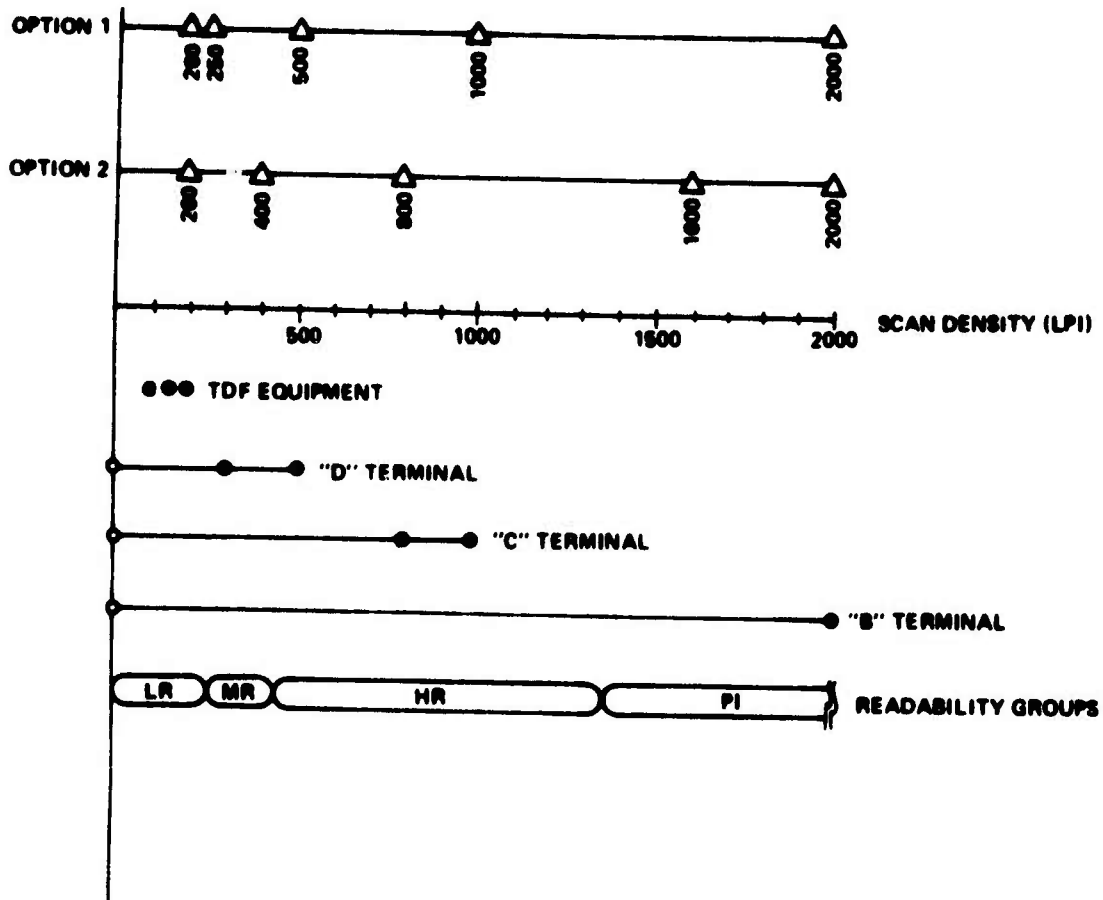

Figure 3.7. Scan Density Selection Options

(2000 lpi) and successively decreasing the value by two, thereby producing scan densities of 1000, 500, and 250 lpi. (Note that 1000 and 500 lpi fall within bounds set for the "C" and "D" terminal, respectively.) Incompatibility arises at the lower end of the readability spectrum because this selection is not consistent with any of the TDF scan densities.

The second option begins by selecting the highest TDF scan density (200 lpi) and successively increasing this by a factor of two; thereby producing 400, 800, and 1600 lpi scan densities which fall within the bounds set by the "D," "C," and "B" terminals, respectively. To these scan densities we must add the capability to effect transmission at 2000 lpi. The effect is to make reception of 2000 lpi imagery with unity scale factor on equipment which operates at a basic scan density of either 800 or 1600 lpi a difficult task which places unrealistically severe requirements on the data processing equipment. It is believed that the requirement for operating at 2000 lpi should be constrained to situations where communication is between "B" terminals only. When PI quality imagery is to be transmitted to either C or D terminals, it can be scanned at 1600 lpi over the 32 kb/s link. We believe the option which operates at 200, 400, 800, 1600 and 2000 lpi is the best choice and meets all current readability requirements.

3.1.4 Recording Media Considerations

The two candidate recording materials which are currently being used for image recording and will continue to be used in the FY 1980 time frame include conventional wet processed silver halide film and 3M dry silver film and paper. Wet and dry processed recording materials are commercially available in a wide variety of characteristics to meet the requirements of many applications. The leading domestic manufacturer of wet processed recording material, Eastman Kodak, supplies silver halide material on both a transparent film base and an opaque paper base. The 3M Company, the leading supplier of heat processed recording media, similarly supplies sensitized film and paper.

At the present time, silver halide wet processed transparent film holds an unrivaled position in applications where the ultimate in imagery quality is desired. By proper control of the recording and developing processes, exceptionally high resolution, uniform response and long tonal range can be achieved. It is readily available in a variety of formulations which cover a broad spectrum of performance characteristics. For the terminals under evaluation silver halide film is not the limiting performance factor. The price one pays for high quality is the inconvenience of handling and replenishing wet chemicals and the costs for maintaining operational processing equipment.

Heat processed dry silver film is in the early stages of the development cycle. Of the six commercially available films, two are specifically designed for image recording: type 7859 for P-31 CRT exposure and type 7869 sensitized for peak response corresponding to the helium-neon laser wavelength. Although the resolution ($>100 \sim / \text{mm}$) and maximum density ($>3.0D$) are adequate to meet some requirements, this material does not currently offer the same high degree of image uniformity, long scale range, and archival keeping quality when compared to silver halide film. Dry silver film is currently about 25 percent more expensive than the combination of silver halide film, wet chemistry and chemistry mixing labor costs. These estimates are based on current GSA schedule prices for 200-foot film rolls and do not account for higher silver halide processor maintenance costs, downtime due to chemical spillage and less troublesome operation. One of

the most significant recent developments regarding dry silver film is progress on developing the so-called hard top coat or HTC films. The process has the primary advantage that the film can now be processed in the same heat processor used to develop the dry silver paper. Care must be taken to ensure exact control of the developing temperature to produce uniformly processed images. Experience indicates that platen temperature must be controlled to within $\pm 0.5^{\circ}$ C to achieve consistent results but that temperature can be regulated to achieve results which may be considered compatible with the low end of the high readability performance group but not uniform enough to record PI quality imagery.

The situation with recording paper is somewhat different. In the past, a silver halide based stabilization paper was used in most high quality photographic quality recording applications. This paper produces high quality images but requires a two-step wet chemistry process to produce the image. We have demonstrated that pictures of equivalent quality can be produced at lower cost per image. This is due to the laser techniques used to reproduce the image and in part due to recent dramatic improvements in the recording media. Experience with facsimile equipment which operates at the low end of the medium readability group indicates that the standard 7771 paper base material may be limiting the resolution of the product. Furthermore, a significant improvement in readability can be achieved by using a still experimental polyester base material. This base material will be more costly but may provide the difference between useable and unuseable medium readability paper products scanned at 400 lines per inch.

One of the primary limitations of dry silver film and paper is the greater susceptibility of these products to environmental conditions - especially excessive temperature. This appears to be a limitation only under extreme operational conditions involving tactical missions. In this case, the care with which the recording material must be stored is outweighed by the operational convenience of a dry process. In most situations, normal film handling procedures are adequate to preserve image quality.

A detailed analysis of various wet and dry recording materials is beyond the scope of this study and depends to a large extent on the specific design details of the recorder. We can, however, make some general observations regarding the applicability of these materials to specific terminal configurations. Firstly, experience indicates that only silver halide film is currently capable of meeting the general requirements of PI quality imagery. This condition is likely to remain so into the FY 1980 time frame.

High readability requirements recorded at 800 lines per inch can be satisfied by both dry silver film and wet processed film. At the present time, the grey shade reproduction of dry silver film is marginal for this readability group but we expect that improvements will be made by the FY 1980 to improve the repeatability of the tonal scale. The medium readability requirements of 400 scan lines per inch are currently satisfied by dry silver film. It appears that currently available dry silver paper and even the newer polyester base opaque material is only marginally acceptable for medium readability imagery. Even though no paper products are able to support the quality requirements, they should be considered as an inexpensive means for obtaining minimally acceptable opaque copy. Paper base copy is completely unacceptable for HR and PI quality applications. Figure 3.8 shows the practical resolution limits for the four types of imaging media which may be considered applicable to each readability group.

Finally, it is instructive to examine the sensitivity of various recording media to determine the amount of energy which is required to expose it. This evaluation is aimed at estimating a rough order of magnitude for the required power so it will not be rigorous. A plot of scan rate versus scan density is again a useful one with which to compare results. A useful parameter for recording images is the instantaneous area scan rate measured in area per unit time. When this is multiplied by recording medium sensitivity and divided by optical efficiency, we arrive at value for laser power, i.e.,

$$P_L = \frac{(IASR) (s)}{\eta}$$

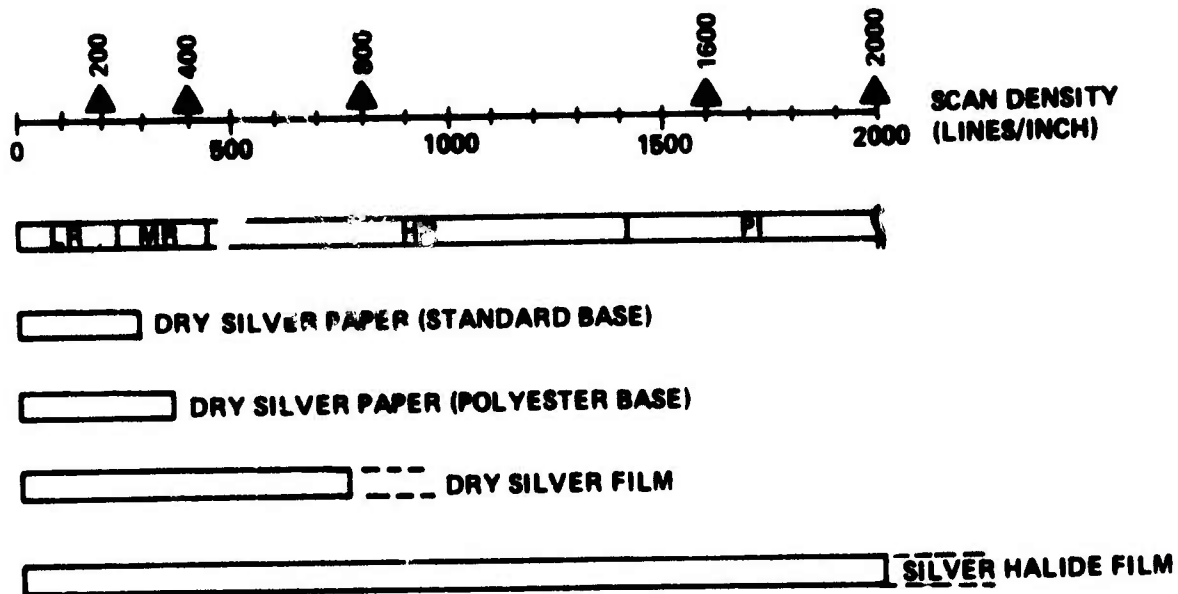

Figure 3.8. Application Range for Recording Data

where P_L is required laser power in watts
IASR is recording rate in in^2/sec
 d is media sensitivity in $\text{watt-sec}/\text{in}^2$, and
 η is optical system efficiency.

If we restrict our discussion to a standard 9 inch by 9 inch frame, it is possible to express IASR in terms of scan rate, R , and scan density, S , by:

$$\text{IASR} = 9 R/S$$

where R is the scan rate in lines per second and
 S is the scan density in lines per inch.

Substituting for IASR and solving for R yields:

$$R = \frac{P_L \eta S}{9 d}$$

Figure 3.9 shows this equation plotted for various values of laser power and 3M Brand Type 7869 Dry Silver Film. We have used a sensitivity value of 300 ergs/cm^2 or $1.94 (10^{-4}) \text{ watt-sec/in}^2$ for Type 7869 which is the least sensitive recording material under consideration. A helium-neon laser has been chosen because of its high reliability and low-noise characteristics. An overall optical efficiency of 5 percent is assumed.

The primary observation regarding this calculation relates to the application of dry silver film in the medium readability recorder which operates at 400 scan lines per inch and at about 30 scan lines per second to fill the 32 kb/s link at 20:1 data compression. For these values, a laser power of only about 2 milliwatts is required - a value which is readily obtainable from a number of small and reliable commercial lasers and is typical of the laser power currently used in commercial facsimile equipment. The general conclusion one reaches is that both recording media and laser power requirements are well within the state of the art for all terminal requirements.

In summary, both 3M Brand dry silver products and conventional wet processed films will find applications in the various terminal configurations. The 3M Brand dry silver film is recommended for rapid access to medium readability imagery recorded at 400 lpi. We have showed that only low power lasers are required to expose this material. To preserve the overall resolution and image quality of high readability and PI quality imagery, we recommend the use of conventional wet processed film.

FIGURE NOTES

IMAGE SIZE - 9" X 9"
 QUANTIZATION - 6 BITS/SAMPLE
 DUTY CYCLE - 80%
 3M BRAND 7009 DRY SILVER FILM
 HELIUM - NEON LASER
 5% OPTICAL EFFICIENCY
 CURVE A - 32 KB/SEC (20:1 COMPRESSION)
 CURVE B - 1.5 MB/SEC (NO COMPRESSION)
 CURVE C - 1.5 MB/SEC (5.5:1 COMPRESSION)

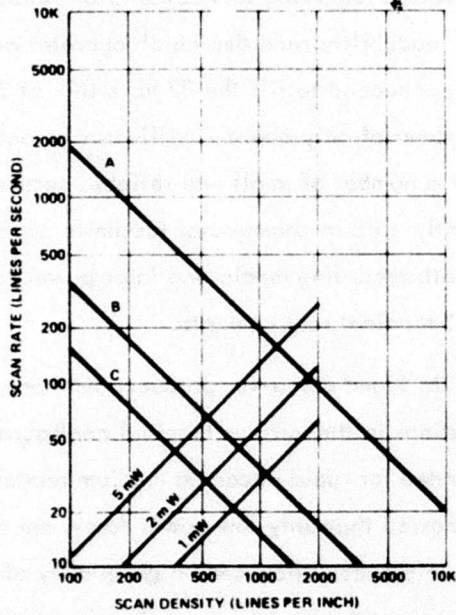

Figure 3.9. Recorder Laser Power Requirements

3.2 Recorder/Scanner Candidates

The previous section discussed several technology factors associated with image recording and scanning, and placed some bounds on the speed and resolution attainable with the technology. Using this information, some specific schemes are now examined for implementing the image recorder/scanner in terms of terminal requirements. Candidates include: (1) laser-galvanometer types, (2) cathode ray tube (CRT) types, (3) drum recorder/scanners and (4) laser beam recorders (LBR). It is believed that these four candidates, which now dominate the medium and high quality imaging recorder/scanner market, will continue to do so well beyond the FY 1980 time frame.

Specifically omitted are two candidate approaches which have either been developed or are being developed for special applications. The first of these is electron beam recorder (EBR) technology which is capable of exceptionally high quality and high speed operation and actively competes with LBR technology. EBR has been omitted because of the difficulty and cost associated with producing 9 inch by 13 inch images. Also, the applications of LED or laser diode recorder/scanner have not been considered because they do not currently provide any significant operational advantage over the other candidate technology and will find application in the marketplace only after recording material sensitivity is extended to longer wavelengths. It is expected that visible gas and ion lasers will be the preferred light source well into the FY 1980 time frame.

It is beyond the scope of this study to provide a detailed second level design analysis of the four candidate recorder/scanners. Rather, we evaluate top level design and operational parameters and their impact on terminal performance.

3.2.1 Laser-Galvanometer Recorder/Scanner

In Paragraph 3.1.2 the laser-galvanometer (L/G) recorder/scanner approach was categorized as one which is capable of supporting medium readability imagery. Successful implementation and field service for commercial L/G technology has taken place over the past few years by application to the Associated Press Laserphoto wire service. The TDF equipment currently under development also uses this technology but in the low readability region. The key elements of the L/G equipment are: (1) a laser, usually a low

power helium-neon type; (2) a modulator to change the intensity of the light during the recording process (e.g., an acousto-optic modulator); (3) a galvanometer-mounted mirror used to sweep laser beam across the recording medium, (4) focussing optics to form a recording spot and; (5) a mechanism for moving the recording medium past the scanned line. Figure 3.10, as an example, shows the components which are used in the Harris ESD product line of Laserfax equipment. This equipment is capable of operating in the lower

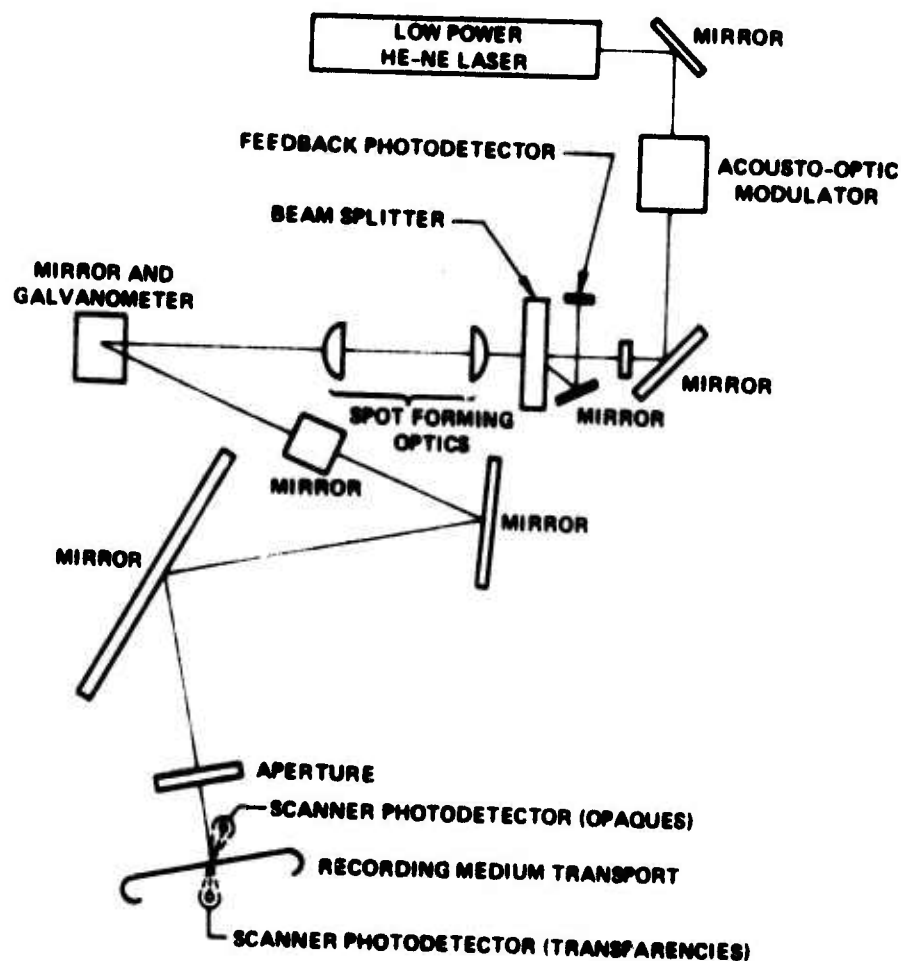

Figure 3.10. Laser-Galvanometer Recorder/Scanner Components

quality portion of the medium readability group and at scanning speeds near 50 scan lines per second. For operation at 400 scan lines per second, the same general arrangement is used but two additions are made to the system: 1) an auxiliary lens which flattens the field

of the scanning spot and 2) a linear grating through which a portion of the beam is directed to and subsequently detected to produce accurate timing for accessing the data buffer. The major components required to implement this scheme are shown in Figure 3.11.

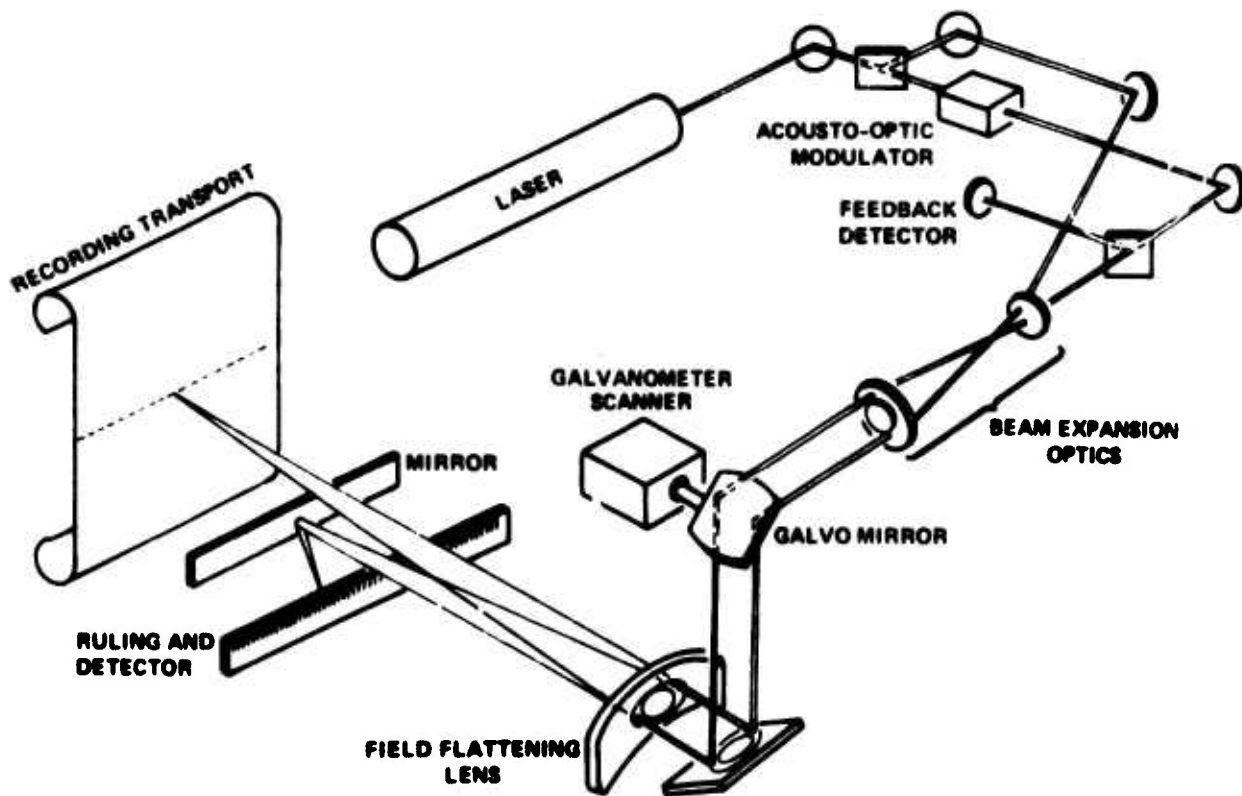

Figure 3.11. Improved Laser-Galvanometer Implementation

Similar optical, mechanical and electrical components are required for the L/G scanner. In this case, an unmodulated laser beam scans either an opaque paper copy or transparent film. For paper scanning, the light reflected from the surface is detected by either a single long detector or a series of individual segments connected together electrically. For transparency scanning, the detector is mounted behind the platen into which an aperture has been cut. The light which is detected has therefore been modulated by the film density variations. Both scanning methods have been successfully implemented on the L/G equipment.

Although it is possible to configure a transceiver design for the L/G equipment, separate transmitter and receiver implementation is favored. This approach is particularly attractive for the case where only "D_{RO}" terminals are required and minimizes the cost of these terminals. The L/G approach can be designed to meet the requirements of medium readability imagery and is the recommended image recorder/scanner for medium readability applications.

In addition to the performance advantages of L/G technology, it offers functional advantages over other medium readability image device technology. Specifically, the transmitter and receiver modules are relatively small and light. The size of the transmitter is typically 1.3 cubic feet and weighs about 40 pounds while the receiver is about 7.8 cubic feet and weighs 120 pounds. Both are mounted on a tabletop and are easily transportable.

3.2.2 Cathode Ray Tube (CRT) Recorder/Scanner

A CRT recorder/scanner approach would be applicable for medium readability applications and is therefore competitive with the laser-galvanometer approach. The laser, modulator and galvanometer deflector are replaced with a line scan CRT. The line is imaged onto the recording medium by conventional optics or fiber optics. The scanning function is performed by using an unmodulated CRT beam and the reflected (or transmitted) light is detected in a manner similar to that described for the L/G approach. The recording medium is stepped past the CRT scan line just as it is for the L/G and LBR approach.

The primary equipment limitations that we identify for CRT recorders are marginal performance when exposing dry silver recording material and a significantly lower MTBF. Experience with CRT recorders indicate that image quality is to a large extent dependent upon the quality of the phosphor and fiber optics. It is almost impossible to produce defect-free CRT's and fiber-optic assemblies, the result of which is a characteristic pattern noise which is difficult and costly to eliminate.

The MTBF of a CRT is estimated at 3,000 hours. Assuming a replacement cost of \$5,000 for a commercial high quality CRT yields an operating cost of \$1.67 per hour. By comparison, the L/G laser head, with a 10,000 hour MTBF and a \$1,000 replacement cost yields an estimated operating cost of \$0.10 per hour. The operational cost of this factor alone on several hundred "D" terminal receivers and transmitters is significant impact.

CRT recording technology is a mature one which has (and will continue to) served well in both commercial and military applications. Although it is capable of satisfying the performance requirements of medium readability imagery, it is not recommended for new equipment design. Laser-galvanometer technology coupled with dry silver recording material is already replacing CRT technology in medium readability applications. By the FY 1980, L/G technology will be the dominant one for medium readability and medium speed applications.

3.2.3 Drum Recorder/Scanners

The concept of using drum recorders and scanners for recording images precedes most of the other technology which is discussed in this section. The rotation of a drum, which is governed by accurate servo speed control, provides one of the best and most reliable means for achieving linear scan velocity. To achieve cross track motion of the recording spot, a carriage is usually moved along the drum axis - either continuously or in asynchronous steps. The discussion of drum recorder/scanner design principles is beyond the scope of this study. Rather, a few of the major factors which influence the application of this technology to image transmission will be highlighted. As indicated in Paragraph 3.1.2, the drum is capable of producing image quality across the entire range of readability groups but is limited in speed to practical limits of 50 scan lines per second. This corresponds to a drum rotation rate of 3,000 r/min. Although some applications can exceed this value, it is clear that higher rotation rates compound the problem of holding the recording material onto the drum surface. In any case, the worst-case drum speed required to meet the 1.5 Mb/s link requirements is about 1,800 r/min. (It is assumed that the "C" terminal need not

transmit 800 lpi data over a 1.5 Mb/s link.) The requirements of the link would be satisfied by the drum if the system were operating synchronously and the recording carriage were translated down the drum axis and producing a helical trace. In practice this is not possible so that one must provide for stepping the carriage to adjacent scan lines. The limitation for the carriage step-and-settle time is similar to that for a film transport mechanism; i.e., a few milliseconds for the cycle. To accommodate for this motion, the drum diameter is usually increased to provide some additional dead time around the circumference. This time decreases the duty cycle and increases the instantaneous data rate requirement. The design tasks involved here usually require a trade-off of these and other factors to arrive at compromise solutions.

The availability of efficient and reliable acousto-optic beam deflectors now permits the implementation of a technique which does not require the use of carriage step-and-settle mechanisms and thereby minimized drum diameter and decreases the instantaneous data rate. The scheme for implementing this is shown in the sketch of Figure 3.12. The acousto-optic beam deflector, which is mounted in the carriage housing, is capable of deflecting the laser beam along the axis of drum depending upon the frequency and modulation of the signal applied to the deflector. For discussion purposes, assume that the drum is recording at 2,000 scan lines per inch or 0.0005 inch between lines. The position of the beam along the drum axis is controlled by two signals, one derived from a linear encoder which runs the length of the drum and is commonly used on precision drum recorders and another signal derived from the rotational drum encoder used to strobe out data onto the drum. The linear encoder defines absolute carriage position while the drum rotation encoder supplies correction signals depending on the angular position of the drum. The carriage rate is not dependent upon drum rotation rate and in fact operates in a quasi-asynchronous manner.

The same principle of using acousto-optics to improve the operability of drum recorder/scanners can be used to increase the flexibility. In selecting a scan density for high readability and PI quality imagery, 800 and 1,600 lpi were chosen as multiples of the 200 lpi TDF scan density. However, it was also required to provide capability at 2,000 lpi. These unrelated scanning densities can be recorded on a

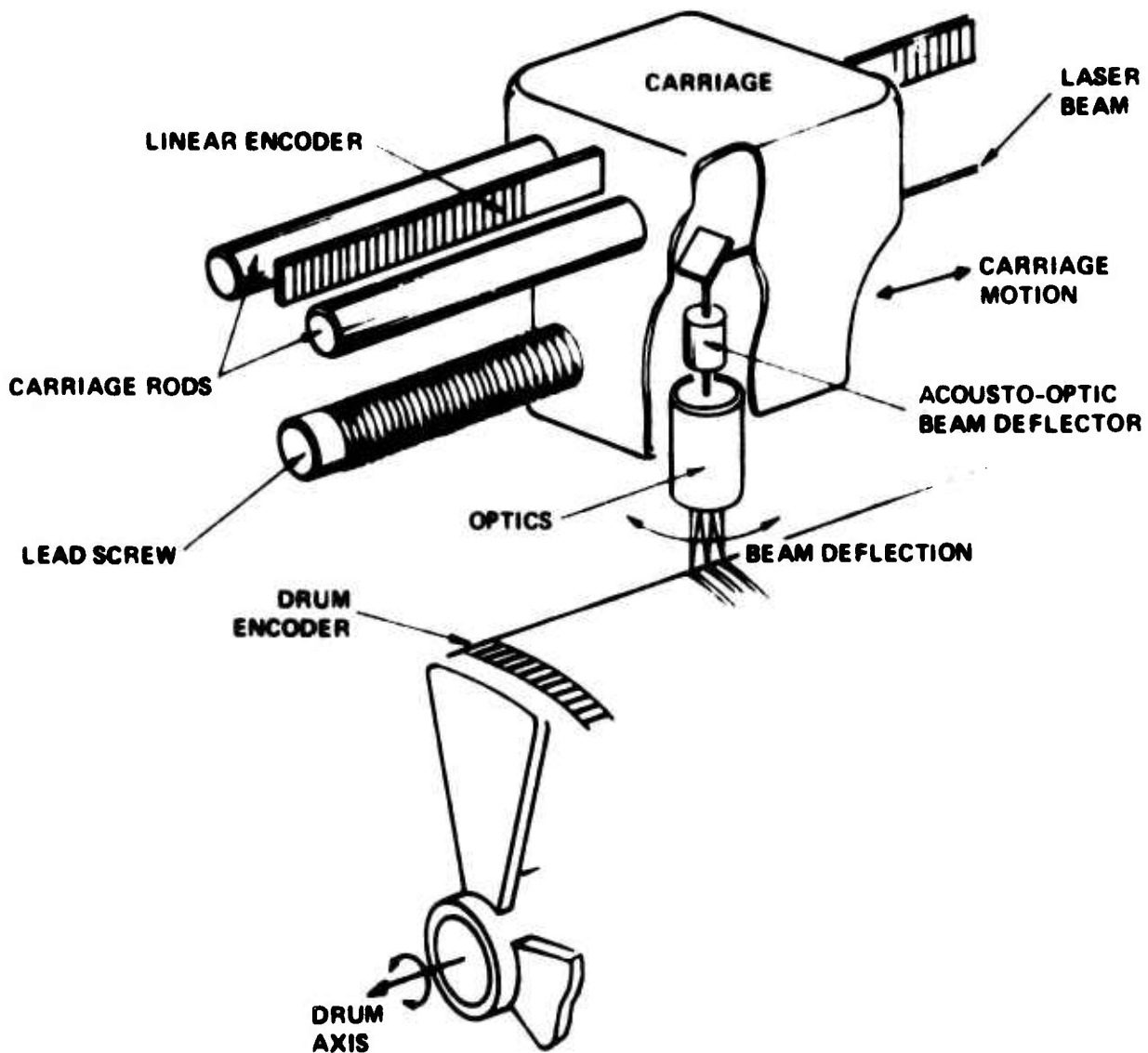

Figure 3.12. Acousto-Optically Controlled Down Recorder/Scanner

single drum scanner without physically modifying the recorder. The acousto-optic beam deflector is now used to "dither" the basic 2,000 lpi recording spot along the axis of the drum to achieve 800 and 1,600 lpi recording and scanning resolutions. A high frequency signal is applied to the acousto-optic deflector to achieve the dither effect. Consequently, a versatile recording and scanning device is obtained which covers both HR and PI quality imagery.

The scanning function is relatively easy to implement on a drum device. The detector, which can be of small size and high speed capability, is located near the recording plane and intercepts the light reflected from the surface. The same light source is used to illuminate the copy. For HR and PI quality imagery, film is the only medium which will support the resolution and grey shade. Experience has shown that film can be read in reflectance by supporting the base with a diffuse backing material. This eliminates the problem of using transparent drum cylinders for the scanning operation.

A word is in order regarding the degree of automation, especially regarding unattended operation of the image recorder/scanner. It is possible to design an automatic loading and unloading mechanism for the drum recorder. This mechanism could load 9 inch x 13 inch sheets of film onto the drum prior to recording and unload them into a catchbox upon completion of the recording operation. Such a mechanism is useful only in applications where high throughput is of paramount importance. A careful examination of the image loading should be made before this decision is made. In order to maximize terminal reliability, automatic loading mechanisms should be avoided unless all throughput traffic requirements indicated otherwise.

3.2.4 Laser Beam Recorder/Scanners

The key technology involved in laser beam recorders is contained in five major components: the laser, the optical modulator, the beam deflector, the film handling mechanisms and the recording media. The choice of laser is dictated primarily by the power required to expose the recording medium, the desired signal-to-noise ratio and, in some cases, the MTF of the recording system. Three types of lasers have been successfully used to record high resolution imagery including the common helium-neon type, the newer helium-cadmium type, which produces energy in the near ultra-violet, and the argon-ion laser, capable of producing several watts of coherent radiation.

Two types of optical modulators are used in high performance laser recorders: The electro-optic type, which modulates light by an electronically-controlled change in the refractive index of the active crystal, and the acousto-optic

type, which produces a refractive index change that forms a microscopic phase grating across the laser beam. Unless some special feature of the electro-optic process is required, the acousto-optic modulator is generally superior in all but the most unusual applications. Rise time less than 100 nanoseconds and extinction ratios in excess of 1500 are easily obtainable in off-the-shelf devices.

Current laser beam recorders which produce 20,000 spot resolution on continuous copy roll film all use multifaceted rotating mirrors to achieve the scanning motion across the film. Galvanometers are not capable of achieving 20,000 spot resolution at the required scan rates. Acousto-optic beam deflectors are limited by time-bandwidth product constraints to applications which require microsecond sweep times but less than 2,000 spot resolution. The two basic multifaceted mirror spinner configurations include scan-before-focus and focus-before-scan types. The scan-before-focus approach is used in conjunction with a special F/θ lens which is designed to produce a uniform scan on a flat field. The principal advantage of this approach is that it leads to a less complex film transport and permits recording directly on the drive capstan. The focus-before-scan approach does not require special lens design because the focussing lens always operates on-axis. A curved recording film platen is used to compensate for large field curvature produced by this type of scanning. The curved platen approach results in somewhat more complex film threading and film transport mechanisms. Both approaches have been successfully employed in high resolution scanners. The cost of a specially designed lens is usually offset by the cost of machining curved platens resulting in comparable cost impacts.

The high performance laser beam recorder is not considered to be a suitable candidate for producing PI quality imagery because of high cost. Its use would be recommended only if the link requirements were significantly higher than specified. For example, an LBR is a likely choice if PI quality (2,000 lpi) imagery, and lower were to be transmitted over 1.5 Mb/s links with 5.5:1 data compression.

3.2.5 Terminal Recorder/Scanner Recommendations

Several recorder/scanner technologies have been discussed in the four preceding paragraphs on the basis of technical performance factors. Table 3.1 summarizes the relative rankings of these technologies when viewed in terms of initial and operating costs for typical implementations.

Table 3.1. Recorder/Scanner Cost Dependent Factors

<u>Type</u>	<u>Initial Cost</u>	<u>Operating Cost</u>	<u>MTBF</u>
Laser-Galvo	low	low	long
CRT	med.	low/med.	med.
Drum	med./high	low	long
LBR	high	med./high	med./short

The evaluation of recorder/scanner technology leads to some obvious recommendations for configuring the four terminals. The recommendation for MR imagery is separate laser galvanometer transmitters and receivers operating at a scan density of 400 lines per inch with dry silver paper and film. This is the only image device required for the "D" and "D_{RO}" terminal. To handle PI quality imagery a drum recorder/scanner (transceiver) is recommended which operates at 800, 1,600 and 2,000 lpi. The "B" terminal will therefore contain both a 400 lpi L/G recorder and scanner but also a drum transceiver. The "C" terminal will similarly contain a L/G recorder and scanner but a drum which is capable of handling only 800 lpi imagery. Only minor modifications would be required to be made to this drum configuration for upgrading to "B" terminal capability. The hardware description and performance parameters for the individual terminals is discussed in Section 4.0.

3.3 Terminal Input and Output Consideration

The three primary aspects of terminal input and output products and functions are:

- e The recorder/scanner recording media
- e The degree of automated unattended operation which should be implemented
- e The feasibility of providing a store and forward capability within the terminal

Paragraph 3.1.4 discussed various recording media options in relationship to the requirements for image terminal readability. Consequently, the evaluation in this section will be confined to the latter two points listed above.

3.3.1 Operational Concepts

Figure 3.13 gives a relatively complete top level summary of the possible levels of automation within the transmitter and receiver, but neglects the remainder of the system including the communication link. As shown, both receiver and transmitter can be viewed as being comprised of several functions which may be implemented with varying levels of automation. In general, the level of automation of each of these functions may be independently selected. However, system constraints, such as a requirement for human judgment in selecting the material to be transmitted, the quality of transmission, the destination, and a second requirement for transmission to multiple receivers, serve to limit the degree of automation of several of the transmitter functions. Receiver function automation is not similarly limited. The receiver function automation levels depicted have been refined for several of the functions by distinguishing between levels of automation which are feasible under local control and those which are feasible under remote control. For example, it is feasible to provide completely automatic selection of the reproduction parameters of a receiver by remote control from the transmitter, but not by local control, due to the variability of the parameters and the lack of information available in the receiver system regarding the values for the present transmission.

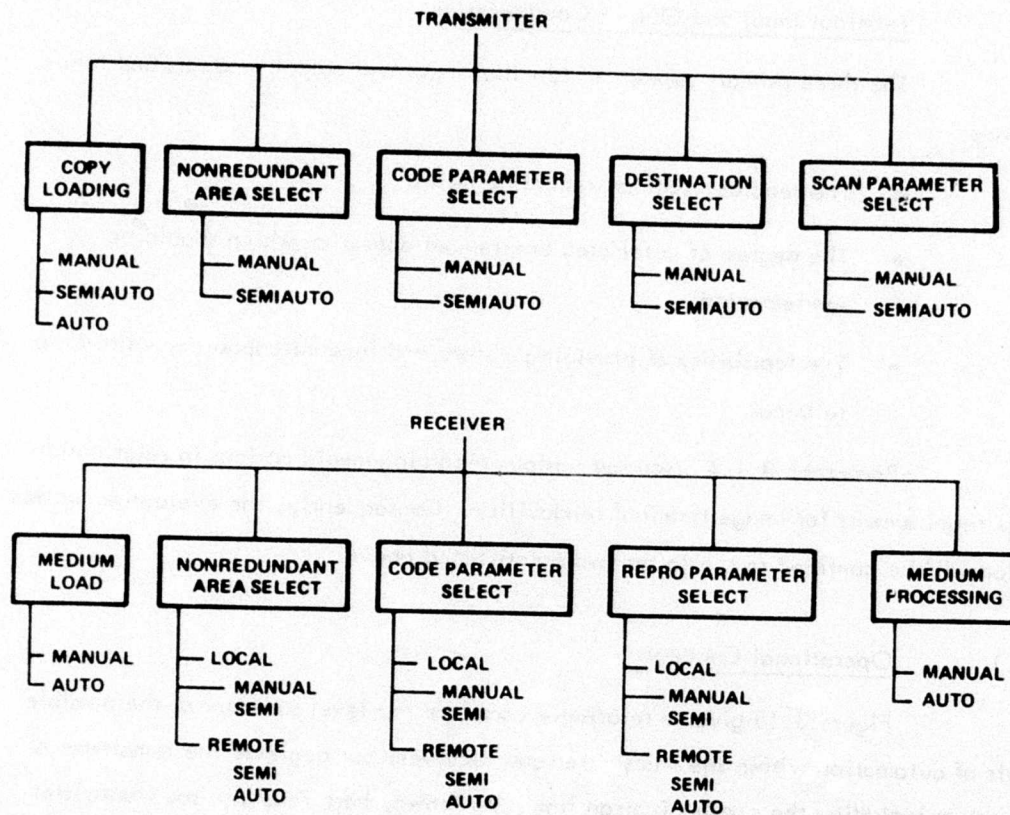

Figure 3.13. Terminal Automation Options

In order to determine the most suitable level of automation for a terminal in the receiver mode of operation, it has been assumed that unattended operation of the receiver is required. The assumption eliminates the choices requiring manual or semi-automatic implementations. The resulting fully automatic receiver mode appears to be well within the state of the art for the medium resolution range. The high resolution and photointerpretable ranges however would require the development of specialized and expensive capabilities as discussed in Paragraph 3.2. For this reason, a slightly less automated approach appears to be more cost-effective. In this approach, the medium resolution portion of all terminals is capable of fully automatic reception. The remaining

portion, if any, of all terminals is capable of fully automatic reception with the exception that manual loading and removal of film is required. The "B" and "C" terminals are thus capable of receiving one picture at high resolution and many at medium resolution without manual intervention.

The most suitable level of automation for the transmitter may be determined in a similar manner. In this case, the proper choice is much less well defined. In the absence of statistical data on the expected values for the various parameters, use of fixed preprogrammed parameter value tables is not required. The choice falls between completely manual selection and some form of semiautomatic selection in which a single selection input controls all parameters that are uniquely determined by that selection. An example of the latter is selection of both line-to-line spacing and along-scan sample spacing for a system in which it is desirable to maintain equal resolution in both dimensions by means of a single selection input. Simplicity of operation requires that the latter approach be taken. Copy loading, for the reasons discussed above, should be manual for the high resolution portion of the "B" and "C" terminals and automatic for the medium resolution portion of all terminals.

On a systems level, it is apparent that the functions of synchronization and fill character insertion and removal must be automated to achieve the desired performance. This area is described in more detail in Paragraph 2.2. The basic point of interest is that the reproducer has a fixed line length so that it will accept the data following a line sync word up to the maximum line length or next line sync word for reproduction. A line sync word starts each line. If line sync words are further apart than the maximum number of samples in a line, all excess samples are treated as fill words and deleted.

3.3.2 Store and Forward Operation

Addition of image storage capability to the basic terminal provides certain advantages which are listed below:

<u>Terminal Mode</u>	<u>Recorded Data</u>	<u>Advantages/Disadvantages</u>
• Receive	Clear Unencoded	Multiple copies with different scales from one transmission. Transmitter of this terminal free to transmit. Reproduction may be done off line.
• Receive	Clear Encoded or Secure	Picture start may be delayed. Multiple copies with different scales from one transmission. Decoding may be done off line. Reduced storage.
• Transmit	Secure	Picture start may be delayed. Encoding may be done off line. Receiver free to receive. Transmitter free to transmit. Reduced storage.
• Transmit	Clear Encoded	Picture start may be delayed. Encoding may be done off line. Reduced storage.
• Transmit	Clear Unencoded	Picture start may be delayed. Scanning may be done off line.

Only one COMSEC equipment and one encoder per terminal has been assumed. There may be some advantage in using temporary storage, but only if dedicated communication links are not used.

Communications security requirements prevent a single controller and data recorder from being used in all of the modes mentioned above. The data recorder may be either clear or secure, but not both. For this reason the data recorder should interface

to the data processing equipment and be used in the clear modes, avoiding the necessity for a complex controller and an additional data recorder while still yielding most of the advantages listed.

The expression for the bit capacity of a digitized image is given in Section 2.0. An image with 6 bit quantization measuring 9 X 9 inches and scanned at 400 lpi contains $7.8 (10^7)$ bits. Candidate storage devices should be capable of storing several equivalent images. The current technology which is applicable is:

- Digital Magnetic Tape - has a capacity of $3.7 (10^8)$ bits (about 5 images per reel) with read/write speeds at selectable fixed rates of up to $5.8 (10^5)$ bits/sec.
- Analog Magnetic Tape (Linear Scan) - has a capacity of $7.2 (10^9)$ bits (about 90 images) with read/write speeds up to $3.2 (10^7)$ bits/sec.
- Helical Scan Digital Tape - has capacity of $7.5 (10^{10})$ bits (almost 1000 images) with average read/write speed of $6.3 (10^6)$ bits/sec and maximum fixed speed of $8.1 (10^6)$ bits/sec.
- Disk - has capacity of $0.7 (10^9)$ bits (about nine images) with fixed read/write speed of $6.4 (10^6)$ bits/sec.

The various types of magnetic tape units exhibit a major disadvantage in this type of system configuration because of the variable access rate. When used as the transmitter data source, the tape must provide a line of data on demand from the data processor input buffer or operate only with the encoded data. When used as the receiver data source, the tape must provide a line of data on demand from the data processor input buffer or the reproducer output buffer. The tape transports currently available are not well suited to this type of operation - including the analog magnetic tape and helical scan digital tape. Start/stop times for these two types are on the order of seconds resulting in long intercard gaps. To utilize these techniques efficiently, the data processor buffer size must be increased to handle several seconds of data. This represents an

increase of several orders of magnitude over standard requirements so it is not an attractive solution. Digital magnetic tape transport stop or start in milliseconds, but the capacity of the tape is not very high.

The magnetic disk memory, however, suffers from none of these problems. No buffer size increase is required because the access time is no more than 20 milliseconds per line. The storage capacity is sufficiently large for three disks to be used for high scan density image storage.

Other technologies showing considerable promise for this application by the 1980 time frame are charge coupled device (CCD) memories and magnetic bubble memories. Presently these devices are experimental in nature, with indications that the cost and performance may eventually be competitive with the magnetic disk. One CCD memory device has been commercially introduced at a cost of 0.15 cents per bit with further reductions expected. This compares with a cost of 0.003 cent per bit for the disk subsystem discussed above. The CCD or magnetic bubble memory lends itself to ruggedization more readily than the disk. Since these technologies are immature at present, the prediction of precise cost trends is much more difficult than for the magnetic tape or disk.

The additional capabilities offered by the addition of picture storage to the terminal must be evaluated by the user on the basis of cost-effectiveness. The cost of a nonruggedized disk subsystem is approximately \$70 thousand. The option of store-and-forward operation is technically feasible and implementable with currently available hardware. We consider it to be an exercisable option but have not included it in the terminal configurations.

3.4 Terminal Intercompatibility

Terminal intercompatibility is one of the key requirements to ensure flexible system response to dynamic situations. A high degree of flexibility is required to respond rapidly to changing military and political situations. Several advantages may be realized if the network system and the terminals are configured so that every terminal type be capable of communicating with every other terminal type. For "B" and "C" terminals, an intercompatibility configuration in which transmit or receive portions of the equipment are used tends to increase the availability of the network.

Transmission capability from a low level ("D" or "DR0") terminal to a high level terminal ("B" or "C") is a basic requirement of this approach. Upwards compatibility is realized by including the capability within each terminal to receive transmissions from lower level terminals. This may be accomplished by providing an image recorder of the type used in the "D" terminal as part of the "B" and "C" terminal. The volume of incoming data can be increased or decreased, if required, by the data processor.

The overall impact of intercompatibility is to allow the system to be reconfigured in a variety of ways subject only to the communication system constraints and the basic terminal parameters. Depending on the availability of suitable communication links and the operational situation, networks may be merged, increased or decreased in size, and added or deleted.

Terminal types "B," "C," and "D" can easily be configured to allow automatic arbitration of image recorder type, recorder spot size, image quantization, and pixel/line deletion or repetition so that any terminal can transmit to any mix of receiving terminals either simultaneously or one at a time. The configuration of a typical multidrop system is shown in Figure 3.14. If terminal "B" is to transmit to "C" and "D" terminals in the net, manual inputs to the "B" terminal cause data to be scanned and transmitted at 800 lines and pixels per inch. The resolution of the transmitted data is signalled to the receiving terminals in the set-up word as indicated in Section 2.0. The "C" terminal receives the data and utilizes it without modifying the resolution. The "D" terminal deletes alternate lines and pixels of data to convert the received data to a compatible resolution.

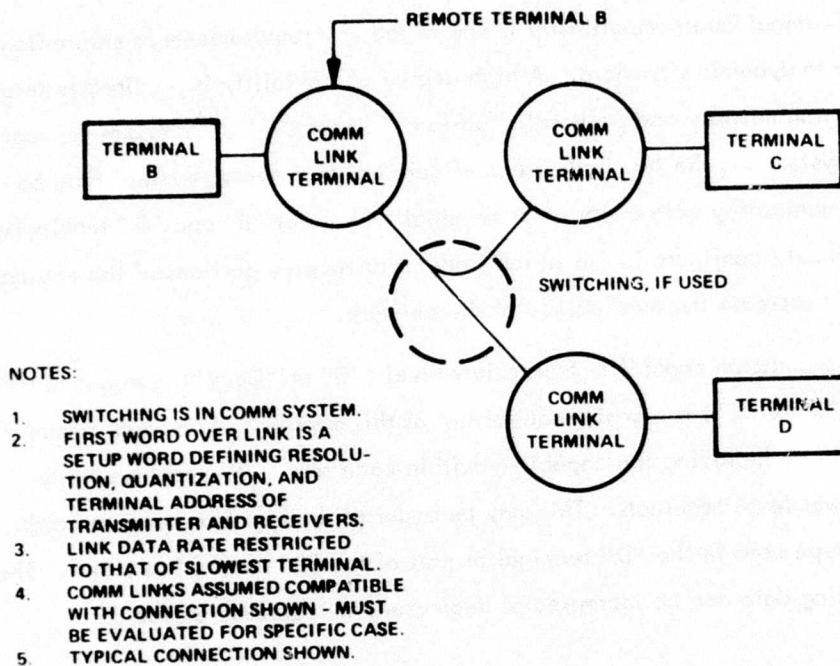

Figure 3.14 Terminal Multidrop Arrangement

In general, the data is scanned and transmitted at a resolution equal to the highest resolution which is reproducible by any single receiving terminal. Other receiving terminals would then convert the received data into a suitable resolution by line and pixel deletion. For those instances where the original data does not require high resolution reproduction, where time is an overriding factor, or where the transmitter does not have the capacity to transmit at any higher resolution, the receiving terminals utilize the proper reproducer to ensure compatibility. Note that line and pixel repetition is never required in a unity scale factor reproduction. For example, if the "D" terminal is the transmitter in Figure 3.14, the data is transmitted at 400 lines and pixels per inch. The "B" and "C" terminals would use the laser/galvo recorder contained in the terminal and reproduce the data as transmitted, without modification of the resolution. The reproducer is chosen by the receiving terminal on the basis of the set up word received.

Unattended operation, except for replenishment of paper, maintenance and repair, is thus permissible between any levels of terminals as long as the data is transmitted and received at 200 or 400 lines and pixels per inch. High resolution transmissions use a drum scanner and reproducer which require manual loading and unloading at both transmitter and receivers. Operation with other than unity scale factor also requires manual intervention at transmitter and/or receivers. Note that the discussion in this section relegates the link switching, if any, and the crypto synchronization to the communication system.

If a portion of an image or an image of less than 9 by 13 inches in size is to be transmitted, the transmitter must be informed which portion of the image is to be transmitted or the size of the image. This information is manually entered from the image area designator device.

This device allows designation of image areas 1 inch square for utilization in defining image size and redundant areas to the data processing module. The present concept of this device uses an overlay on the image with 1 inch grid lines, indexed to the upper right corner of the image. A group of pushbuttons provides the means for designating individual 1 inch square areas and the type of compression algorithms used in the redundant areas. The transmitter scans the entire 9 by 13 inch area but transmits only the designated information. Scanning will cease when the remaining portion of the picture contains no additional area designated for transmittal. This approach permits smaller formats to be handled more efficiently.

The same feature is used to transmit a magnified version of a small image. Magnification is accomplished by scanning at one scan density and recording at another. For example, a 2 inch square portion of the image could be scanned by a "B" terminal at 1600 lpi by reception as a "B," "C," or "D" terminal. This would be accomplished by selecting the area to be scanned by the image area designator and causing the transmitter data processing module to identify the 1600 lpi data as 400 lpi data to the receiver. The effect would be to cause the linear dimensions of objects in the magnified image to be four times larger than in the original image scanned. Similarly 2X magnification is accomplished by scanning at twice the scan density of the reproduction. It should be

noted that the results of the magnification process described above are effectively identical to employing optical magnification of the corresponding value (2X or 4X) on a 2 inch square image scanned and reproduced at 1600 lpi. Objects slightly above the limit of detection in the 1600 lpi reproduction appear correspondingly larger, but still only slightly above the limit of detection in the 400 lpi reproduction.

Magnification is also possible by scanning and reproducing at the same scan density, with each data sample and each line repeated twice for 2X magnification. This is called "empty magnification" because the objects in the image appear twice as large, but do not contain more information. Empty magnification could be employed to achieve magnification between terminals with the same scan density.

3.5 Terminal Modularity

A natural method of upgrading terminal performance is by exchanging a portion of the terminal for higher performance hardware or by adding equipment to an existing configuration to improve terminal capability. The primary advantage of modular design is that it affords a means for upgrading terminal performance with minimal cost impact. The two major subsystems considered for modular implementation are the recorder/scanner subsystem and the data processing subsystem.

The recorder/scanner subsystem modularity concept must be considered in terms of its application in the various terminal configurations. The lowest performance configuration is one using only the laser-galvanometer recorder for reception of 400 lpi imagery in the "D_{RO}" terminal. The image recorder receives data at 400 lpi but is capable of recording at two spot sizes - one which is consistent with 400 lpi resolution and another which has twice the spot size but still scans at 400 lpi. This latter approach tends to produce a more uniformly pleasing image than one produced by merely dropping pixels and lines for 200 lpi operation. The laser-galvanometer recorder records on either 3 M brand dry silver paper or film from continuous 200 foot rolls. Image sizes of up to 9 inches by 13 inches can be easily accommodated. The recording medium is processed automatically after completion of the recording sequence.

The image recording and scanning capability of the "D_{RO}" terminal may be upgraded to "D" terminal status by adding a laser-galvanometer scanner module. It too is designed to operate at 400 lpi but has the capability of scanning with two different spot sizes.

For performance beyond medium readability capability, a drum recorder/scanner is added. The initial step to "C" terminal status requires the addition of one capable of operating at 800 lpi. For "B" terminal capability, this drum is further modified to provide both 1600 and 2000 lpi recording and scanning capability. Input and output media for use with the drum equipment is restricted to film which is manually loaded and unloaded from the device.

Six data processing module options are recommended to cover the full range of terminal requirements. The first of these is the basic "D" terminal Data Processor, a bipolar microprocessor based device that performs the functions of setup, encoding, decoding and data buffering. This function is illustrated by Figure 3.15.

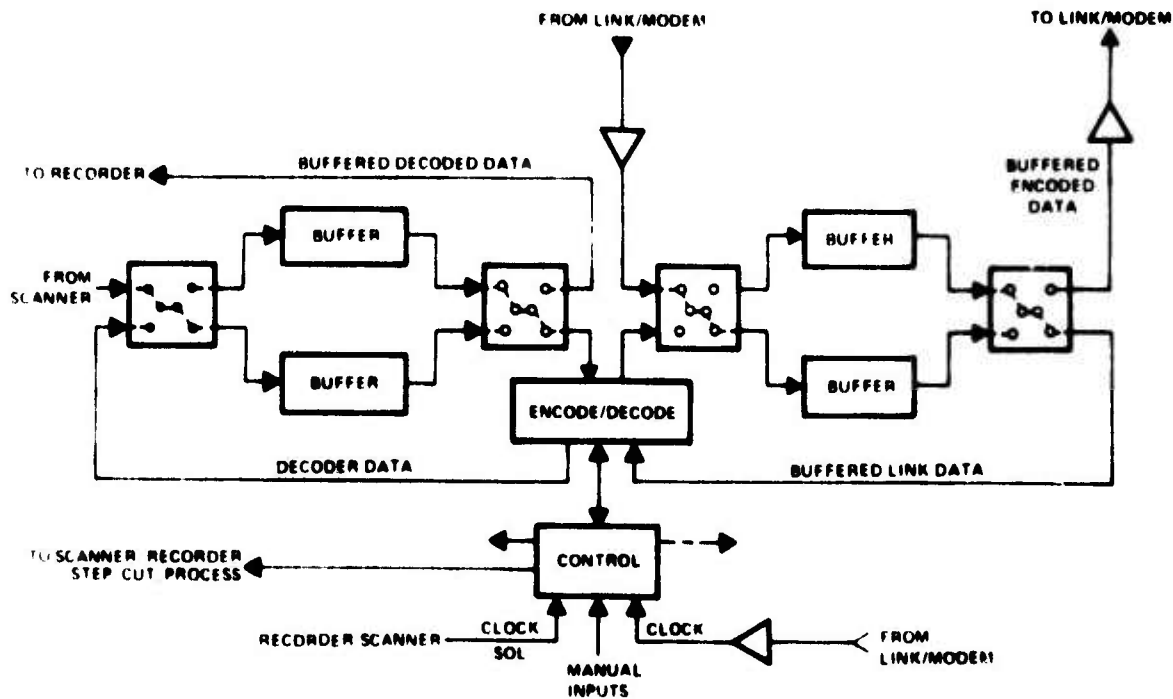

Figure 3.15. Basic Data Processing Function Diagram

The basic buffer size is 3600 words. The second module provides additional memory to extend the buffers to a 7200 word length which is required for the "C" terminal. The third module provides yet more extension memory for a total of up to 18.0K words which is required for the "B" terminal.

The fourth module is an optional high speed Huffman encoder/decoder which provides an average 2.4 x increase in picture transmission speed. This module is capable of operating at the 1.5Mb/s link rate expected on high bit rate links and provides a measure of data reduction at rates above those for which conventional general purpose serial data processors are feasible. Input buffering is provided in the module.

The fifth module is a high speed buffer/link interface. This unit allows the drum scanner/reproducer to interface to the 1.5 Mb/s link, either directly or through the Huffman code module described above. All buffering necessary for direct interface, as well as sync code insertion is provided by this module. The code output is buffered to the link when used in conjunction with the Huffman encoder/decoder module.

The sixth and final module is the store and forward module. This module provides a magnetic disk and interface to operate as described in Paragraph 3.3.2.

3.6 Security Considerations

The two aspects of security which are sufficiently important to require special attention are:

1. Conformity to TEMPEST requirements
2. Compatibility with COMSEC equipment

The elimination of compromising emanations from the RED terminal equipment must be a goal which is addressed early in the detailed design phase. Experience with the EICS equipment indicates that it is a difficult task to eliminate compromising emanations after the equipment has already been designed and built. As shown in Figure 3.16, the original EICS equipment did not meet the imposed TEMPEST requirements and even after extensive modifications, it was judged to be only marginally conforming.

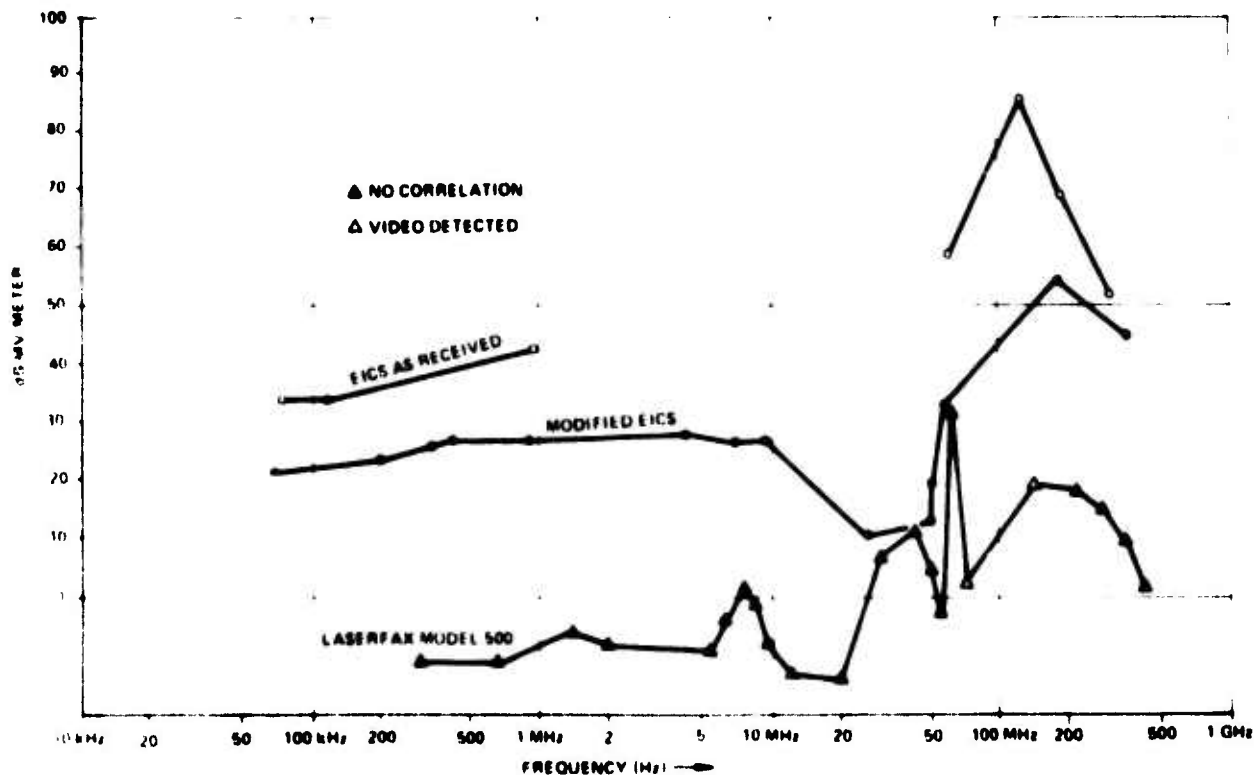

Figure 3.16. EICS and Laserfax TEMPEST Tests

Indications are that the laser-galvanometer equipment will also be difficult to modify to conform to NACSEM 5100 requirements.

Power line filters, located as far as possible from the terminal, should reduce conducted RFI/EMI to an acceptable level. AC power should be conducted to the terminal from the filter through semirigid conduit. The COMSEC equipment should also be located as far as possible from the terminal with shielded cables and optical isolators provided for the RED data interface to the COMSEC equipment. The basic EMI strategy for the terminal is one of containment with EMI cabinets to be used throughout the terminal. Special attention must be paid to the EMI design of the acousto-optic modulator and driving circuitry to reduce emanations from this source. If careful attention is given to the EMI/RFI and TEMPEST aspects of the design the terminal will conform to NACSEM 5100 and MIL-STD-461.

The terminal should be compatible with the applicable COMSEC equipment since it will be compatible with MIL-STD-188C for low level interface. Encryption and decryption devices are normally required to have MIL-STD-188C compatible interfaces. Provision for clock and data input/output lines are common to all COMSEC devices. Other lines for initiation of sync, alarms, and power control are usually present but may vary from one type to the next. Local control should be provided for these functions.

3.7

Communication Interface Considerations

Most communication links in use today are basically analog in nature, even though portions of the link may be digital. Digital signals are transmitted over analog lines by the use of modems at both ends of the link. The modems (modulator-demodulator) convert the digital signal into an analog form suitable for transmission over the analog line at the transmitter and convert the analog form back into digital form at the receiver. Compensation is usually applied to the received analog signal which allows distortion, frequency shift, phase shift noise, and band limiting to occur without disrupting the link. The upper portion of Figure 3.17 illustrates this type of operation and shows a standard MIL-STD-188C low level interface between the terminal and the modem.

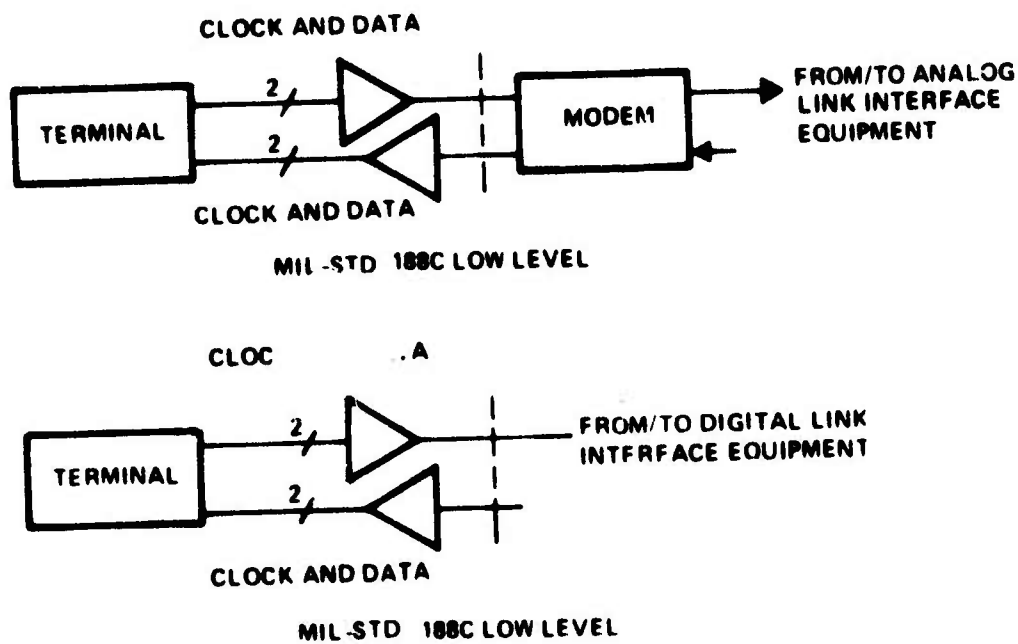

Figure 3.17. Terminal Interface Through MIL-STD-188C

A second type of interface is shown in the lower half of the figure. In this case the communication link interface is digital. The communication link may be totally digital over the entire length or digital over only a portion of the length. Few links today are wholly analog or digital - most are a composite of analog and digital portions. The effect is that there is little difference between the two types of links except for the actual location of the modem which can be either inside or outside of the link.

Another consideration for communication interface is the source of the timing for data transmission. Modems and digital link interfaces may operate either synchronously or asynchronously. At lower speeds, modems are often asynchronous, i.e., operated at a variable bit rate defined by the data source or the transmitter. At high speeds modems are almost always synchronous or operated at fixed bit rates defined by precision timing sources located most commonly within the transmitting modem but sometimes external to the modem in the transmitter. Timing for the receiver is derived from the transmitted data. Similarly, digital link interfaces may be either synchronous or asynchronous. Often digital input data at lower rates are multiplexed digitally, perhaps through several stages, to form a single higher bit rate stream for transmission over a high bit rate link. In this case, timing must be phase locked to the multiplexer rate in order to ensure usable data. At the receiver, the data stream is used to regenerate timing for control of the demultiplexing process. Demultiplexing requires phase-locked timing through the lowest stage.

Accordingly, the terminal operating as a transmitter must be capable of generating the timing signals sent to the modem or link interface, and alternately of accepting the timing signals from the modem or link interface. In the receiving mode, the terminal must be capable of accepting the timing signals from or generating the timing signals for the modem or link interface. Provision for a precision timing source internal to the terminal and selection circuitry for the timing source is a standard design technique.

3.8 Data Compression

During the course of this study, the RADC-developed Redundant Area Coding Scheme (REARCS)^{1, 2} is employed as the baseline approach for achieving high data compression factors. The data compression technique has been successfully implemented and evaluated on an Experimental Image Compression Subsystem (EICS)³ under several RADC-sponsored contracts with HARRIS Electronic Systems Division (Horris ESD). In this section, the basic operating principles of REARCS are reviewed.

The purpose of the Redundant Area Coding Scheme (REARCS) is to reduce data content in a picture so it may be transmitted in minimal time over a communication link. Since not all areas of normal reconnaissance imagery carry the same level of interest, only the areas of high information need to be transmitted exactly. The low-information (redundant) areas are used primarily for orientation, so they can be coded for transmission at the maximum data reduction rate and still be effective. Based on these facts, the REARCS approach applies different coding techniques to the two types of areas. In the nonredundant area, a statistical coding is used to preserve all of the data by coding the data exactly as it is digitized. In the redundant areas, an interpolative step technique is used that can be combined with lower resolution scanning to obtain data compression.

The redundant and nonredundant areas of the picture and the coding techniques in the boundary areas are selected by the operator using a grid matrix. A convenient grid of, say, 1 inch x 1 inch spacing is usually chosen.

In the nonredundant area we use an entropy-preserving statistical code. Starting with the value of one pixel, statistical coding is used to encode the changes in gray levels between adjacent pixels. The frequency of occurrence of

¹ U.S. Patent No. 3743765, Redundant Area Coding System, U.S. Air Force; 4 March 1970.

² "Redundant Area Coding Study," RADC-TR-71-192 September 1972.

³ "Experimental Image Compression Subsystem (EICS)," RADC-TR-74-191 January 1975.

different difference values follows a definite statistical pattern; no-change and single-level changes occur most frequently, while two- and three-level changes occur less often. Table 3.2 is a list of the statistics of level changes which were determined by measuring many different types of reconnaissance images. Only minor changes occur in the statistics of complicated images compared to uncomplicated images.

Table 3.2. Level Change Statistics and Coding

	<u>Huffman Code</u>	<u>Statistical Occurrence (In Percent)</u>
No change	1	68.0
One-level change +	01	12.1
One-level change -	001	12.1
Two-level change +	00011	2.0
Two-level change -	00001	2.0
Three-level change +	0000101	1.2
Three-level change -	000100	1.2
Four-level change +	0000011	0.4
Four-level change -	0000001	0.4
Remainder code	0000010 (followed by a 6-bit data value)	0.6

in order to assign a unique code to each event, a Huffman coding approach is used. The most likely events are assigned the shortest codes. All changes of more than four levels are assigned a new reference by assigning a special code with the absolute 6-bit value of the sample sent right after the code. This form of coding yields 2.0 to 2.4:1 data reductions depending upon the activity of the picture

data. The outstanding characteristic of this code is that it is noninterpolative or entropy-preserving. Thus, if no link errors are introduced, the decoded data will be exactly like the input.

In the redundant areas, an entropy-reducing step coding technique is used. The step coding algorithm is a zero order reduction interpolative technique. The code fixes a reference point with the "next sample" and establishes a tolerance around this point. The subsequent samples are examined to determine if they lie within this tolerance. All consecutive values within the tolerance are transmitted as a single sample with the assigned value of the center of the tolerance range. The count of the samples falling within the tolerance is transmitted as a run length. When a sample falls outside the tolerance, a new "next sample" reference is established using this sample and subsequent samples are tested against this newly established tolerance. The operator can select various tolerances and numbers of lines and samples to be dropped - depending upon the quality he desires to transmit in the redundant area. The transmission time is, of course, affected by the coding; a scheme that preserves more of the original data will take longer to transmit.

Another feature that has been incorporated in the system is the zoom technique. By using this technique, a small area of the original photograph can be scanned at higher resolution and reproduced on the receiving end in an expanded form at lower resolution. For example it is possible to:

- Scan a 4 inch x 4 inch area at 400 lines/inch and reproduce on the receive end as an 8 inch x 8 inch copy at 200 lines/inch for a X2 expansion.
- Scan a 2 inch x 2 inch area of the original photograph at 800 lines/inch and reproduce on the receive end an 8 inch x 8 inch photograph at 200 lines for a X4 expansion. This capability allows the operator the option of transmitting the whole copy at 200 lines/inch as the first picture in the set, and then zoom in to transmit the small 2 inch square of the picture at an effective 800 lines/inch.

The REARCS technique can be applied to the zoom pictures in the same manner that it was applied to the 1:1 picture. For instance, a 2 inch x 2 inch picture scanned at 800 lines/inch would be divided into 8 x 8 grid squares. Each grid square in this case would be 1/4 inch square. Thus, the operator can select very small areas within the zoom picture to be transmitted at high resolution and the remainder of the area in the zoom picture will be at a lower resolution, depending upon the number of lines and samples dropped. Figure 3.18 illustrates the zoom and the Redundant Area Coding features which can be implemented.

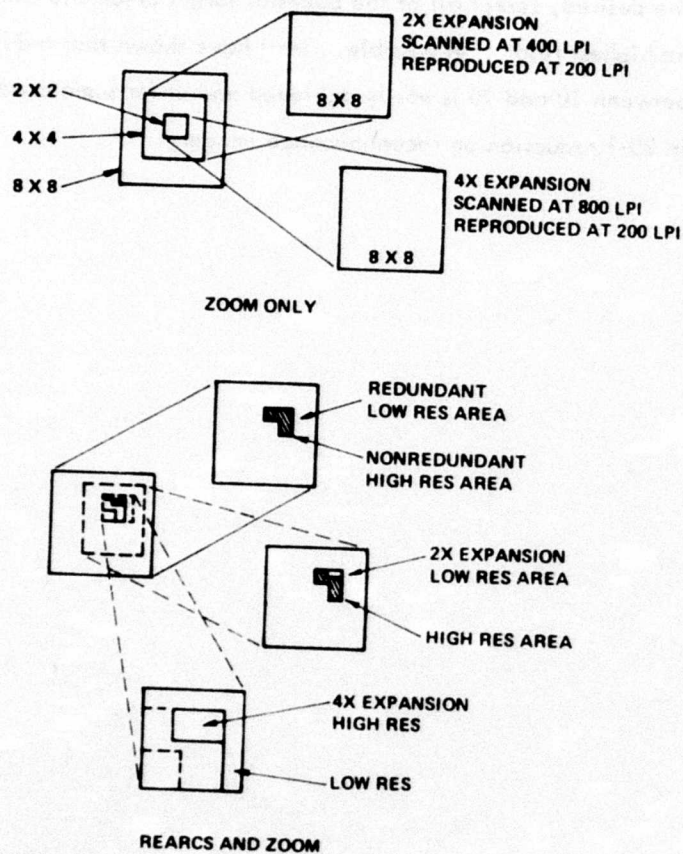

Figure 3.18. REARCS and Zoom Capability

The zoom technique, combined with REARCS has proved to be an extremely effective technique for transmitting intelligence and reconnaissance picture data. The reaction thus far to the use of the two-coding technique and the zoom technique has been very favorable. The EICS testing has shown that the coding combination described is very effective and that the lower resolution in the redundant areas does not affect the usability of the received information. This testing has shown that, on the average, between 5 and 10 boxes are all that are required to designate most of the target areas in any one picture. The system is flexible, however, such that the operator could, if he desired, select all of the boxes as target areas and transmit the entire picture at the highest resolution possible. Tests have shown that a data compression factor of between 10 and 15 is easily achieved and under some conditions, it is possible to obtain 20:1 reduction on reconnaissance imagery.

Data Processing Options

Several different technologies for implementing the data processing functions are considered in this section. The four types of implementation approaches considered are:

1. Hardwired logic
2. Minicomputers
3. MOS microprocessors
4. Bipolar microprocessors

The hardwired logic approach is the conventional one which uses individual MSI logic elements in a parallel organization to perform the buffering, encoding and decoding, and interface functions. The logic design is specifically tailored to the stored program coding algorithm which is to be used. This approach is relatively inflexible but offers the highest speed capability of any of the methods of implementation considered. Minor changes to the coding algorithm may not be implemented without expensive redesign and replacement or rework of the hardware. Although no software cost is incurred using this approach, the hardware cost is high; consequently, the overall cost is the highest of the approaches considered. The size of the control memory is dependent upon the specific stored program algorithm but it is usually smaller than for other implementation technologies.

The minicomputer approach generally offers the system designer a rapid implementation cycle and a relatively low level of design and programming effort. The primary advantages of a minicomputer approach include availability of ruggedized models as well as a wide range of software packages and peripheral equipment all of which are supported by systems oriented customer service. The disadvantages include limited operating speed, size and long delivery schedules.

The microprocessor approach utilizes LSI techniques to provide a word-parallel central processor using very few integrated circuits. Although no basic difference exists between minicomputers and microcomputers, a few trends can be identified.

Minicomputers are usually purchased as complete systems including power supplies and memory whereas microcomputers are purchased as either complete systems or sets of integrated circuits without power supplies, memory, or mounting hardware. Although present minicomputers are being fabricated with TTL and MSI circuitry, the trend is toward implementing minicomputers with LSI microprocessor chips.

The microprocessor is most often used in a dedicated application instead of as a general purpose machine; consequently, relatively little system support software is available for most microprocessors when compared with minicomputers. The minicomputer architecture is generally more easy to implement than the microprocessor because of the pin-out constraints on the LSI packages.

The two most common microprocessors available today are based on either MOS or bipolar technology. The MOS technology yields more complex and versatile chips but bipolar circuitry is much faster. The table below compares several key parameters.

Table 3.3. MOS and Bipolar Microprocessor Comparison

	<u>MOS</u>	<u>Bipolar</u>
Word Sizes (Bits)	4,8,16	2, 4
Speed Ranges (Macro Instruction Time)	2-60 μ s	.5-2 μ s
Architecture Types	Monolithic Functional Slice Bit Slice	Bit Slice
Languages	Macro Micro	Micro

Table 3.3. MOS and Bipolar Microprocessor Comparison (Continued)

	<u>MOS</u>	<u>Bipolar</u>
Software Aids	(X) Assemblers Editors Loaders 1-Higher Level Language Simulators	1-X Assembler For Micro-Code
Hardware Aids	Real-Time Development Systems	None

The general cost, speed and flexibility trade-offs are compared for the four data processing technologies in the Figure 3.19. The bipolar microprocessor offers greater

PARAMETER PROCESSOR	COST	SPEED	FLEXIBILITY
HARDWIRED LOGIC	HIGHEST	FASTEST	LOWEST
MINICOMPUTER	MODERATE	MODERATE	HIGHEST
MOS MICROPROCESSOR	LOWEST	SLOWEST	MODERATE
BIPOLAR MICROPROCESSOR	MODERATELY HIGH	MODERATELY FAST	MODERATELY HIGH

Figure 3.19. General Data Processing Trade-Offs

speed than the minicomputer at similar flexibility and cost levels. The hardware cost for the bipolar microprocessor includes firmware to perform the required coding algorithm. Firmware changes can be easily accomplished by card replacement to permit changes in the coding algorithm. Ruggedization of the bipolar microprocessor is easily accomplished. The minicomputer approach offers very high flexibility; accomplished by changes to the software. This approach does not offer the speed of the bipolar microprocessor and is quite expensive if ruggedization is required. Additional peripherals are required to

achieve full flexibility. The MOS microprocessor offers the lowest cost approach but is also the slowest. The operation of a MOS microprocessor may be changed by modifying the firmware.

The speed of operation of the four processing technologies is superimposed on a graph of computer operations versus data compression ratio as shown in Figure 3.20.

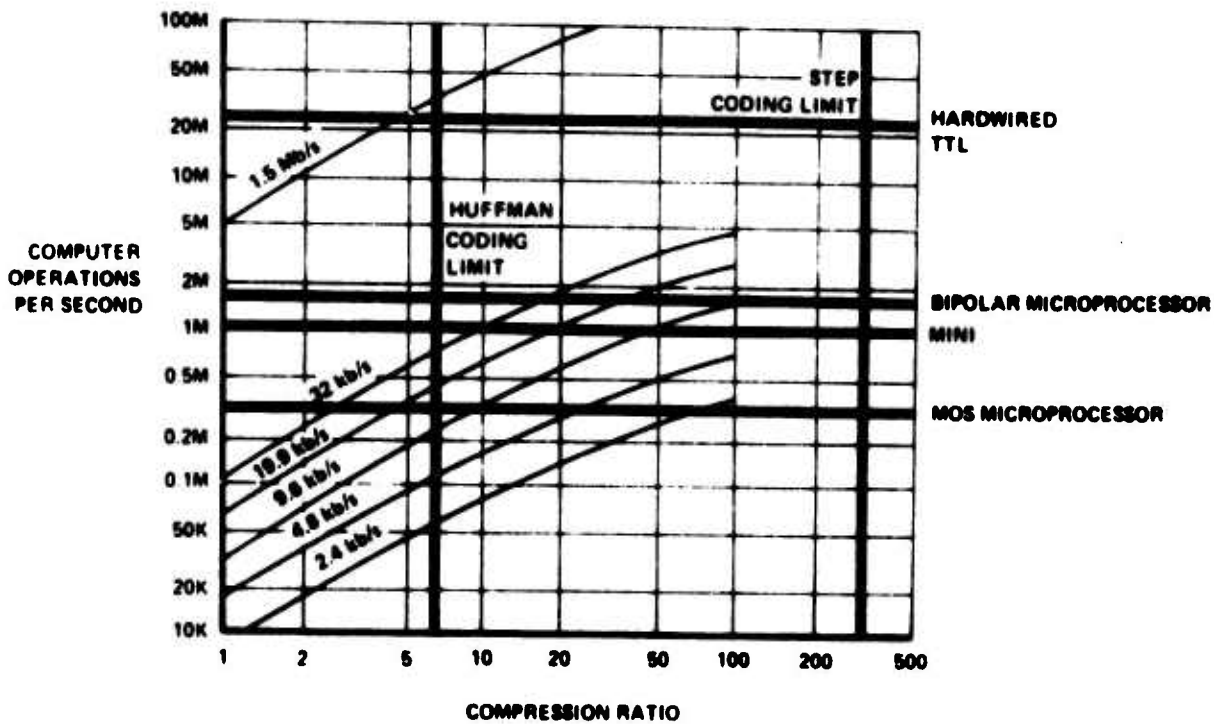

Figure 3.20. Data Compression Processing Limitations

The operating speed of the data processor is determined by the data compression factor and the bit rate which must be attained to fill the communications link. The data processing module must operate at a sufficiently high speed to be capable of supplying data to fill the link regardless of the data compression presently occurring.

The number of samples per second which must be processed can be calculated as a function of the bit rate and data compression factor and is given by:

$$Z = \frac{HWS^2}{T} \cdot \frac{LC}{Q + (OH) CHWS^2}$$

where (OH) is the total number of overhead bits C is the compression factor and the other quantities are as defined in Paragraph 2.3. Twenty operations per sample is estimated for implementing the coding algorithm for both the Huffman DPCM and step-coding modes. These operations are simple arithmetic and register-to-register operations which are compatible with microprocessor capabilities.

The calculation made above and plotted in Figure 3.20 for various link rates shows that high speed processing is required to achieve the desired goal of filling a 32 kb/s link at a 20X compression ratio. For this requirement, hardwired TTL logic can be used but a bipolar microprocessor would be marginally usable. Hardwired TTL is also required to meet the speed requirements of a 1.5 Mb/s link without compression and with 5.5X compression.

SECTION 4.0
TERMINAL CONFIGURATIONS

4.0 TERMINAL CONFIGURATIONS

Many of the technical factors which influence the general form, performance and functional features of a terminal are evaluated in Section 3.0. On the basis of these cost-dependent factors, it is possible to synthesize an implementation approach which meets the basic guidelines and objectives of the study. A summary of the recommended configurations and terminal features is presented in this section.

4.1 The "D" Terminal

The "D" terminal forms one of the basic building blocks of any image transmission system which would be constructed using the technology discussed above. This terminal is the one which is most likely to be implemented in large quantities in any practical network arrangement. This terminal transmits (and receives) medium readability imagery (and lower) to (and from) all other types of terminals. A block diagram of the "D" terminal configuration, shown in Figure 4.1, consists of a separate medium readability receiver and transmitter, data processing module with memory buffer and REARCS coder. Communication security and modem equipment are also included in the block diagram but have been treated as part of the communication link. The medium readability receiver is a laser-galvanometer recorder which is capable of recording on either dry silver paper or film. The medium readability transceiver is a laser-galvanometer scanner which can scan either opaque or transparent products. An artist's concept of a commercial grade "D" terminal configuration is shown in Figure 4.2. The laser-galvanometer recorder is located in the center and the smaller scanner unit is shown to the right. The REARCS coding selector grid and associated push button selector switches are located on the top surface of the console. The console, as depicted, contains the data processing, commsec and modem equipment. In practice, the latter two devices may be required to be physically located away from the terminal equipment to meet communication security requirements.

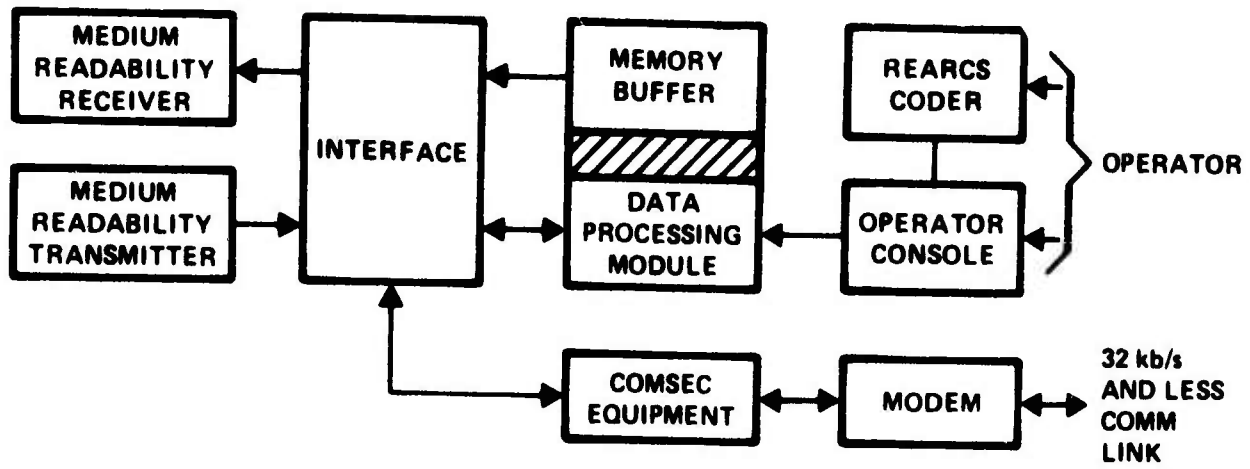

Figure 4.1. "D" Terminal Block Diagram

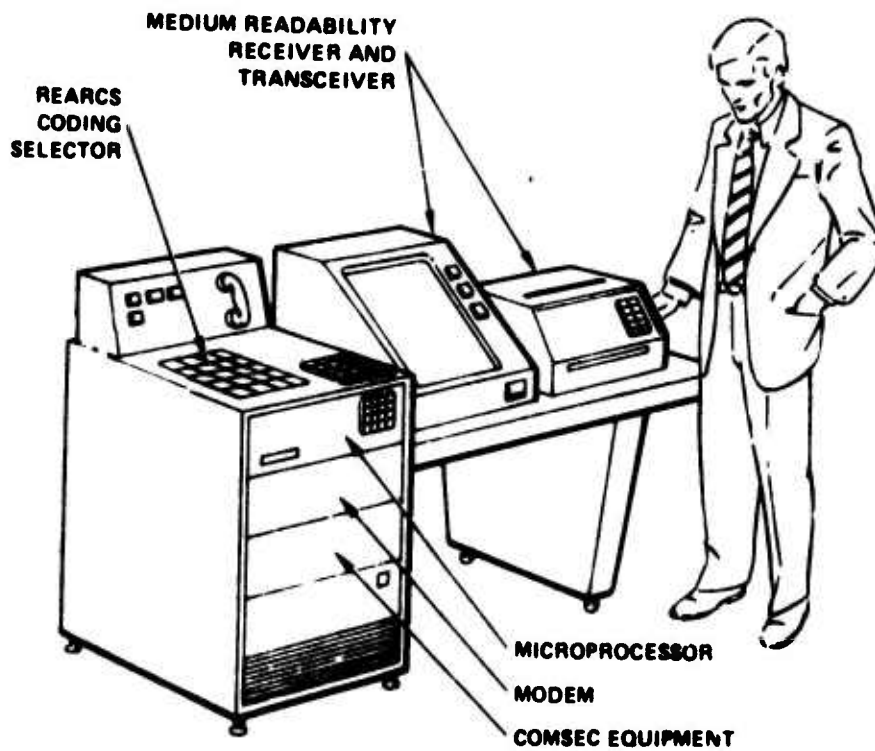

Figure 4.2. "D" Terminal Artist's Conception

The principal top level "D" terminal characteristics and performance parameters are highlighted below:

Laser-Galvanometer Scanner (Transmitter)

- Dual Scan Density: 400 and 200 lpi
- Average scan rate of approximately 30 lps
- Quantization at 6 bits/sample
- Paper opaque or film transparency input medium
- Nine inch wide by 13 inch long image size

Laser-Galvanometer Recorder (Receiver)

- Dual Scan Density: 400 and 200 lpi
- 30 lps average scan rate
- Quantization at 6 bits/sample (5 bits/sample preserved on film)
- Recording medium: 200-foot rolls of 3M Brand Dry Silver Paper or Film
- Nine inch wide by 13 inch long image size
- Positive or negative recording polarity

Data Compression

- Operator Selectable REARCS with Huffman DPCM Coding
- Three operator-selectable tolerance or deletion modes

Communication Interface

- Digital or Analog Communications Links
- MIL-STD-188C Compatible

- Compatible with 2.4, 4.8, 9.6, 16 and 32 kb/s modems
- Compatible with most COMSEC equipment

The primary features of the "D" terminal are:

- Unattended receiver operation
- Dry processed recording materials
- Compatible with all other terminals
- Microprocessor controlled coding and terminal control
- Upward compatibility (modularity)
- Up to 32 kb/s transmission rate
- REARCS compression
- Low-cost laser-galvanometer recorder/scanner

4.2 The "D_{RO}" Terminal

The "D_{RO}" terminal is a descoped version of the "D" terminal and represents the minimum terminal configuration. This terminal is capable of only receiving medium readability imagery (and lower). Consequently, it need not contain all of the equipment required for image scanning and REARCS area selection. This configuration is the one which is most readily adapted to mobile deployable field use. A block diagram of the "D_{RO}" terminal is shown in Figure 4.3. The performance parameters and features are identical to those listed for the recording aspects of the "D" terminal listed in Paragraph 4.1 and are not repeated here.

4.3 The "C" Terminal

The "C" terminal, which is capable of recording and scanning high readability imagery, is configured as shown in the block diagram of Figure 4.4.

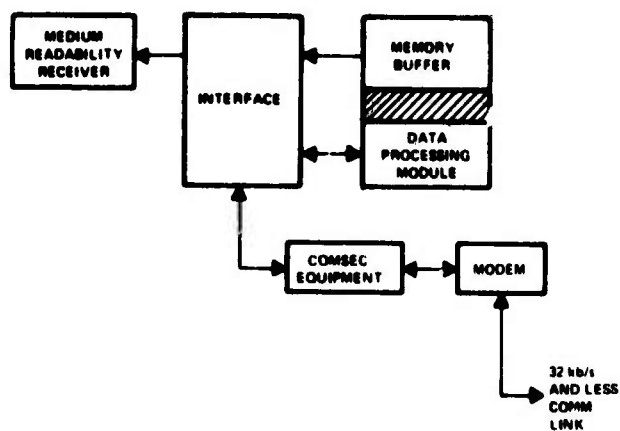

Figure 4.3. "D_{RO}" Terminal Block Diagram

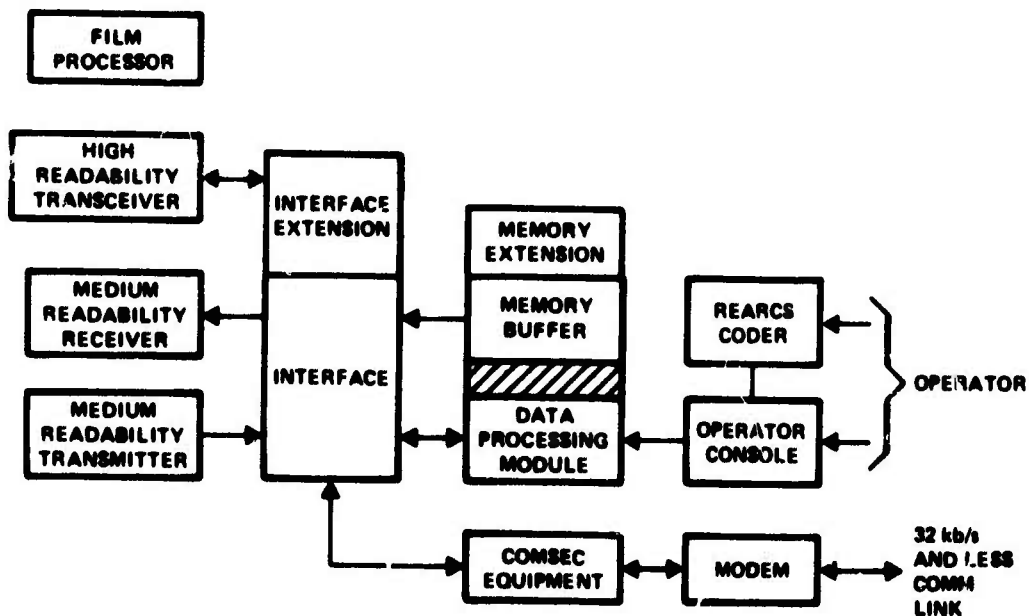

Figure 4.4. "C" Terminal Block Diagram

The major differences between the "C" terminal and the "D" terminal are the addition of a drum recorder/scanner (transceiver) which is used only for high readability imagery, the extension to the memory buffer and interface, and a film processor for the film. The approach taken to achieve terminal modularity is evident by comparing the block diagram of the "D" terminal to the "C" terminal. The equipment characteristics are

identical to those described for the "D" terminal with the exception of those factors which relate to the high readability transceiver. This equipment consists of a laser drum recorder/scanner which has the following characteristics:

- Single scan density at 800 lpi
- Single rotation rate at 2,000 r/min
- Six bit quantization preserved
- Scan and record on wet processed silver halide film
- Nine inch wide by 13 inch long copy size

The physical appearance of the "C" terminal equipment is nearly identical to the "B" terminal equipment shown as an artist's concept in Figure 4.5.

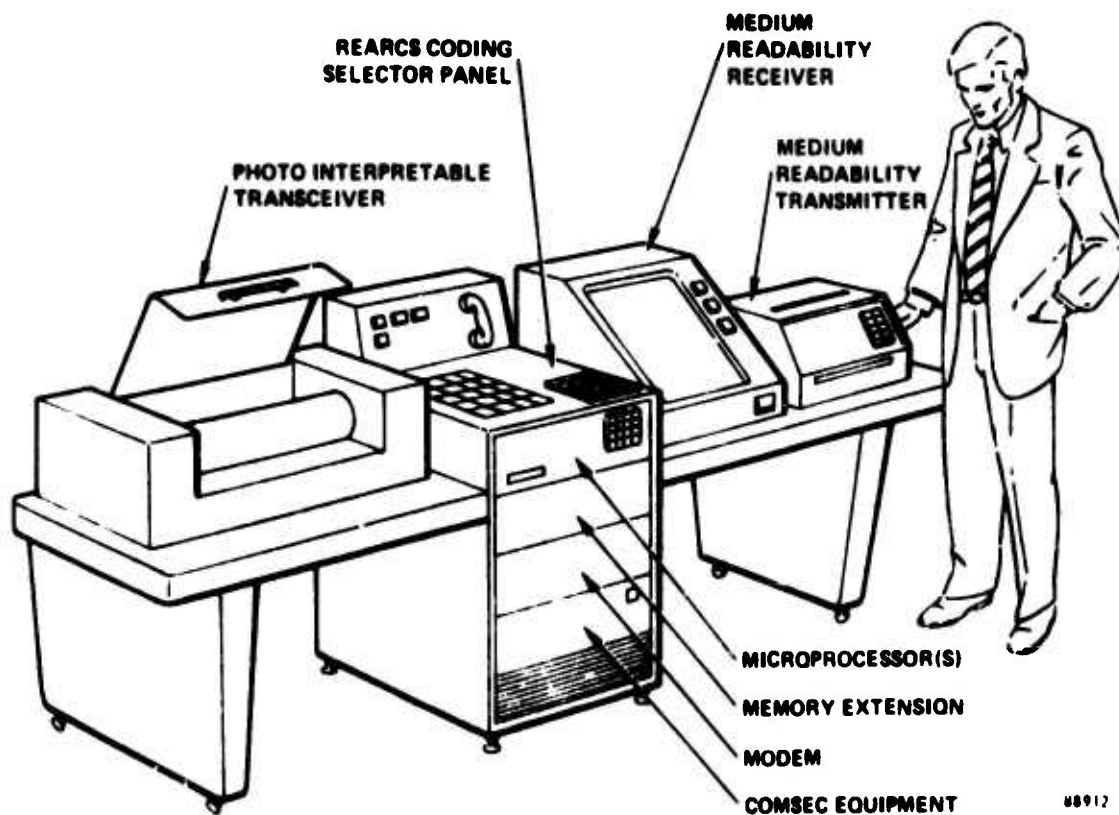

Figure 4.5. "B" Terminal Artist's Conception

4.4 The "B" Terminal

The "B" terminal configuration, which is capable of recording and scanning photo interpretable images, is the most sophisticated and costly of the terminal types. It is implemented by adding capability to the "C" terminal described in the previous section. Figure 4.6 shows a block diagram of the basic "B" terminal components. In this case, the photo interpretable transceiver is an upgraded version of the "C" terminal drum transceiver and operates at three scan densities; 800, 1,600 and 2,000 lpi. The data processing memory extension is greater than required for the "C" terminal.

The normal interconnection path to other terminals is through the 32 kb/s link shown at the bottom of the block diagram. This link is used when the data has been scanned at 400, 800, 1,600 lpi. A high speed channel (1.5 Mb/s) is shown at the top of the diagram for use only when 2,000 lpi imagery is to be transmitted to other "B" terminals. The communication over this link may be made secure and may include

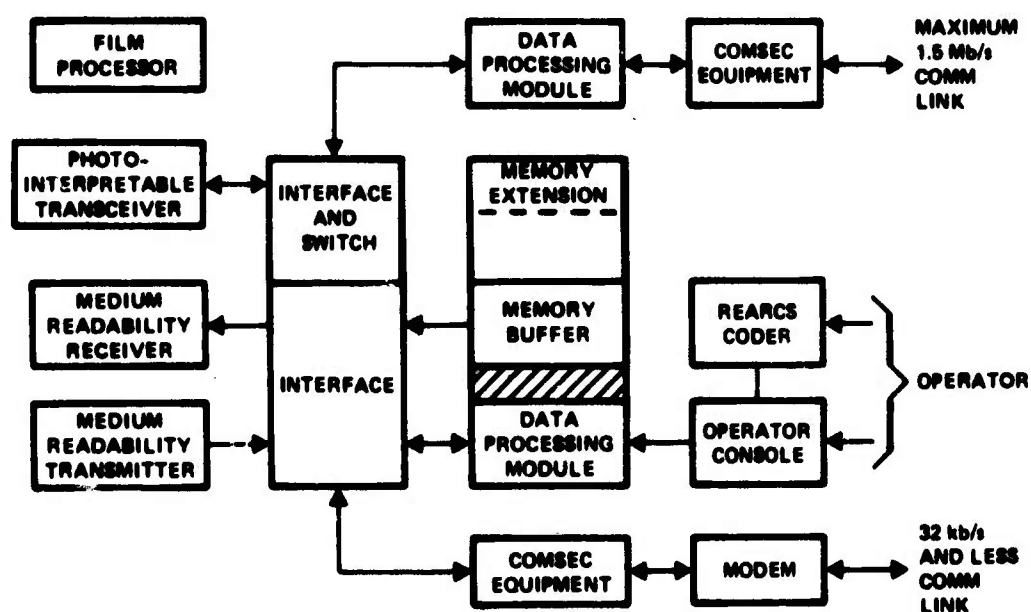

Figure 4.6. "B" Terminal Block Diagram

some form of simple data compression such as Huffman encoded DPCM. Figure 4.7 shows a block diagram of the major blocks required to configure a special channel from the PI quality transceiver over a 1.5 Mb/s communication link.

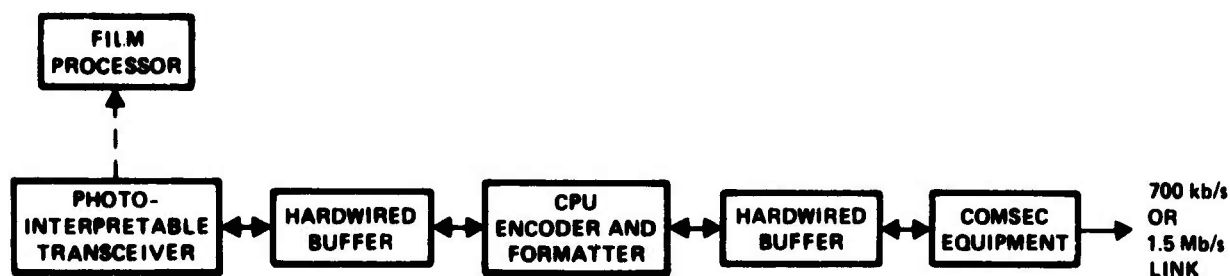

Figure 4.7. "B" Terminal for Photointerpretable Imagery Over High-Speed Communication Links

The principal features of the "B" terminal are listed below:

- Minimum operator intervention in receiver mode
- Low risk drum technology for PI quality
- Up to 32 kb/s transmission plus 1.5 Mb/s option
- REARCS compression at 32 kb/s
- Two-device recorder/scanner
- Operates at 2,000 lpi between "B" terminals
- Operates at 1,600 lpi for backup over lower rate link
- Compatible with all terminals

The ultimate "B" terminal configuration is one which is capable of transmitting and receiving PI quality imagery over 1.5 Mb/s lines with data compression in excess of 5:1. This requirement represents a significant departure from those which

are evaluated in the previous sections. As shown in Paragraph 3.1.2 and 3.9, such a requirement leads one to a terminal configuration requiring an expensive high speed laser beam recorder/scanner and special high speed coding and decoding logic.



SECTION 5.0
PROGRAM CONSIDERATIONS

5.0 PROGRAM CONSIDERATIONS

This section is devoted to a brief discussion of some program related factors which are derived from the analyses made and the conclusions reached in the previous sections. The identified program related factors include recommendations for continued technical evaluation and testing plus cost estimates which are based on the terminal configurations discussed in Section 4.0.

5.1 Technical Considerations

During the course of this study several technical questions arose which, because of the severe time constraints, were not addressed to the depth that is required for a program of this type. Accordingly, the following list is submitted as a recommendation for consideration as advanced development for the program:

1. A detailed trade-off analysis of the different source encoding algorithms for application to the nonredundant areas of the REARCS algorithm is recommended. Analysis of this problem is complicated by several interrelated factors including technical, operational and data origination. The technical factor is primarily related to the performance of the algorithm compared to the complexity of implementing the algorithm. The emphasis should be placed primarily on a comparison of transform codings versus various DPCM entropy-coded approaches. The operational considerations involve both interface compatibility between terminals (i.e., should a common algorithm be used for all terminals?) and the degree of availability of data which may be available only in Fourier-transformed forms. Thirdly, it is possible that data which undergoes cascaded source encoding processes from DPCM through transform encoding may suffer in quality due to the compounding effects of successive operations. An approach to a solution requires that the operational questions be addressed first at the proper clearance level so that the proper framework for technical analysis and simulation can be established.

2. A project to determine a practical "filter" which would reduce the bandwidth requirements of the imagery but still retain adequate information for tactical exploitation is recommended. Throughout this study it has been assumed that a very simple decision process is employed when high quality imagery is transmitted to less sophisticated and lower quality terminals. For example, consider the situation of having 2,000 lpi imagery and a communication bandwidth link to a user which only allows for 800 lpi point rastering. One method, and the simplest, is to transmit one of the pixels in every 2.5×2.5 pixel array. Another approach, and one requiring more storage, is to transmit one pixel which represents the average value of the pixels in the 2.5×2.5 array. This is termed uniform averaging. A more general approach provides for weighted averaging by transmitting one pixel which is the weighted average over one or more arrays of 2.5×2.5 pixels each.

The analysis of this problem requires a trade-off between implementation complexity and the potential for improved image quality from more complex filtering. The trade-off should be made on the basis of impact on the "B" and "D" terminal hardware and software performance and cost. A facility which has the capability for experimentally altering the filtering operations should be used with standard tactical reconnaissance photography to evaluate the effects on image quality.

3. It is recommended that the "specifications" for the MTF amplitude and phase response for the "B" and "D" terminals be formulated. This specification should include both amplitude and phase factors extending from dc to twice the sampling density. The approach recommended is one involving three phases. The first is a detailed analysis of the terminal recorder/scanner transfer functions including the effects of spot profile, modulator bandwidth, recording media limitations, etc., over the operating ranges of the equipment. The

second is an evaluation of the MTF and phase rolloff sensitivity for standard tactical reconnaissance imagery which can be determined largely by experimental techniques. Finally, a detailed second-level design of the "B" and "D" terminals is recommended which would include appropriate filtering concepts to achieve the best performance versus implementation trade-off. The second-level design effort should also include a careful analysis (and experimental verification) of the acousto-optic cross-track dither concept and a thorough characterization of dry silver film and paper for MR and HR image applications.

5.2 Cost and Schedule Considerations

Previous sections dealt with the application of measurable scientific principles. This section will deal with the rather subjective areas of cost and schedule. These parameters could vary significantly depending upon who performs the measurement. The estimates included here are based upon knowledge of typical imagery and data processing equipment development and production costs. Both commercial and military types of equipment will be addressed.

Nonrecurring Activities

Nonrecurring activities are those necessary to take existing equipment, implement new technology and update the designs to provide prototype terminals meeting the requirements presented earlier. Table 5.1 shows estimates of the costs to the Government associated with obtaining the first unit. It should be noted that the estimates are in "1976" dollars.

Table 5.1. First Unit Costs (\$000)

<u>Terminal Type</u>	<u>Commercial Specifications</u>	<u>Military Specifications</u>
"B"	545	1,120
"D"	265	560

NOTE

The nonrecurring cost for the "D" terminal is also included in the cost for the "B" terminal.

In regard to schedule, the first commercial prototype could be delivered 12 months after go-ahead. The military model would probably take 15 months.

Recurring Activities

Estimates of recurring costs for small (≤ 10) lots of terminals in terms of "1976" dollars are shown in Table 5.2.

Table 5.2. Unit Costs in Lots of Ten (\$000)

<u>Terminal Type</u>	<u>Commercial Specifications</u>	<u>Military Specifications</u>
"B"	240	300
"D"	100	180

Program Costs

Three theoretical programs have been investigated in regard to costs and funding requirements. These programs are defined as:

1. **European Test Net** - This program would deploy four "B" and 12 "D" terminals at selected sites in Europe by the beginning of 1977 for evaluation under conditions of actual use. The terminals would be built to commercial specifications.
2. **Solid Shield 1978** - This program would deploy five "B" and five "D" commercially specified terminals within the United States by the end of 1977 for use in the Solid Shield 1978 exercise. Again, evaluation would occur as a result of actual use.
3. **Normal Preproduction Production Program** - This program would be the normal military hardware procurement program with definition, prototype, qualification test, operational evaluation, preproduction and production phases.

For estimating purposes, four prototypes of each terminal types have been included with 27 production "B" terminals and 131 production "D" terminals.

Table 5.3 shows cost estimates applied by calendar year. Factors were included for economies in producing quantities and for the effects of inflation. Costs include nonrecurring efforts and contractor O&M support.

Table 5.3 . Program Costs (\$000)

	<u>1976</u>	<u>1977</u>	<u>1978</u>	<u>1979</u>	<u>1980</u>	<u>1981</u>	<u>1982</u>	<u>Total</u>
European Test Net	2,500	300						2,800
Solid Shield '78	1,300	800	100					2,200
Test Net and Solid Shield	3,500	1,200	100					4,800
Preproduction/Production	1,000	1,500	1,000	6,500	11,000	8,500	3,000	32,500

APPENDIX A1
EUROPEAN COMMUNICATION NETWORK

NETWORK CONSIDERATIONS - EUROPE

A1.0 INTRODUCTION

A look was taken at the assets available for communicating in the European theater of operation during the 1976/1977 time period and beyond. The available assets and means in which they might be utilized has been reported. Recommendations as to what the ground rules might be for establishing an imagery dissemination test in Europe are discussed. Overall evolutionary trends of the DCS and other interfacing communications assets are described herein.

It is understood that a demonstration will be established in the 76/77 time frame in the European theater involving 4 "B" and 12 "D" terminals. No attempt will be made to select the sites since this is the Government's responsibility, but ground rules which could affect the successful outcome of the overall experimental test program and the site selection will be discussed. The flexibility in providing various data rates in addition to the 2400 b/s test system rate will also be covered. DCA-EUR will allocate any circuits required in the DCS assets in the European theater. Rules for describing the needs for the experiment can be derived from the material presented here.

A2.0 EUROPEAN COMMUNICATIONS ASSETS

The current DCS is predominantly analog in nature i.e., the 4 kHz (3 kHz on some undersea cable and HF radio) frequency-division multiplex (FDM) voice channel is the carrier of most of the information transferred over the DCS.

A2.1 AUTOVON

The switched voice network commonly known as AUTOVON is a network of voice channels switched on a space division basis. Data transferred over this network is converted to quasi-analog signals and synchronization between terminals is on an end-to-end basis in the form of both bit time recovered from the received signal and frame or block timing based on specific data stream format. This system is the DCS equivalent of

the commercial telephone system that we all use at home. In addition to the normal functions of the commercial system such functions as preemption, conferencing, survivability, and precedence call initiation are provided. In Europe, the primary AUTOVON switching centers are located in Germany, Italy, England, Greece and Spain as listed in Table A1.

Table A1. European AUTOVON Sites

Feldberg, FROG	Mt. Vergine, Italy
Langerkopf, FROG	Martlesham Heath, UK
Donnersberg, FROG	Hillingdon, UK
Schoenfeld, FROG	Mt. Pateras, Greece
Coltano, Italy	Humosa, Spain

An interconnecting network has been assembled between these circuit switching sites. It is possible to dial anyone in the world who is connected to the AUTOVON telecommunications network and if the dialing party has the correct level of precedence and the other party is available a connection can be accomplished. Any terminal interfacing with AUTOVON which utilizes the correct addressing scheme as spelled out in the AUTOVON standards can communicate with another like terminal.

A2.2 AUTODIN

The switched data network is a message store-and-forward switched network. Data in AUTODIN is transferred over 4 kHz voice channels in a quasi-analog form and synchronization and encryption is on a link-to-link basis; i.e., from user-to-switch, switch-to-switch and switch-to-user. It is a master-slave relationship in that AUTODIN switching centers contain highly accurate clocks and synchronous terminals are configured to be slaved to the timing recovered from data streams received from the switch. Frame and block timing is also obtained through the rigid format and protocol used.

In Europe, there are four AUTODIN store-and-forward message switching centers. These are located in Germany, Italy, and England as shown in Table A2 below.

Table A2. European AUTODIN Sites

Pirmasens, FROG	Coltano, Italy
Augsberg, FROG	Croughton, UK

The AUTODIN Switching Center accepts properly formatted data from subscriber terminals. A hierarchical next level subscriber interface point is the Digital Subscriber Terminal Equipment (DSTE). A terminal requiring digital transfer of information to another terminal may interface either through the DSTE or directly with the AUTODIN Center once it has been ensured that the proper format and blocking is being used. The AUTODIN standards specify the proper manner in which terminals may interface this store-and-forward message switching network.

A2.3 AUTOSEVOCOM

The current secure voice network is switched on a space-division basis over a combination of 4 kHz voice channels and special 50 kb/s conditioned circuits. Depending on the specific circuit setup, synchronization is either on an end-to-end basis or on a user-to-switch-to-user basis or the switch would regenerate the signal.

There are four AUTOSEVOCOM wideband AN/FTC-31 switch sites located in Europe. These are located as shown in Table A3.

Table A3. European AUTOSEVOCOM AN/FTC-31 Switch Sites

London, UK	Heidelberg, FROG
Weisbaden, FROG	Stuttgart, FROG

The current application of this system is to interconnect localized subscribers (those within 20-30 kilometers of each other via a special 50 kb/s wideband service which is automatically switched through the FTC-31 switches). If a long-haul interconnection is required, there is an operator-controlled switchboard called the SEVAC associated with each FTC-31 that allows narrowband 2.4 kb/s to 9.6 kb/s interswitch connection.

Thus, a 50 kb/s subscriber in the London area can be connected to a similar subscriber via the narrowband trunk in the Heidelberg area. The system could be modified to transfer digital data in the immediate areas of each switch at 50 kb/s, or through an augmented store-and-forward method send the data long distance through the narrowband trunks. This could be considered as an optional secure communications capability if properly modified for an experiment. The need for mentioning this possibility here is coupled with the knowledge that the DOD secure voice capability will be changed in the future such that the current AUTOSEVOCOM system is no longer required.

A2.4 DCS Transmission Facilities

There is a significant network of transmission facilities interconnecting the DCS in the European theater of activity. The media includes microwave, cable, troposcatter communication, HF radio and commercial PTT facilities.

Since many of these transmission media interface at relay nodal points, it is not necessary to access the system solely at AUTODIN or AUTOVON switching centers. If a given relay point, let's say, for a microwave connection between two switches has what is called drops, it is possible to enter at this point. In other words, at a given nodal point very often (as can be seen by the attached representative diagram of a subsector of the European theater) the groups of voice grade channels or trunk subsets are split and sent to more than one switching center. Based on the fact that FDM multiplex schemes are currently used, it is possible to enter the system not only at a voice grade level (4 kHz channel) but at the group or supergroup level or, indeed, through proper priority at the microwave level itself. Thus, high data rate modems operating at 48 kb/s upward could be utilized if properly interfaced with either the multiplex banks at relay nodes or at the switching centers themselves.

There is currently one satellite ground station terminal associated with the DCS that is located at Landstuhl. This terminal among other destinations can connect with Ft. Dix in CONUS.

A summary of the transmission facilities that are utilized in the European theater is shown in Table A4.

Table A4. Transmission Facilities - Europe

<u>Microwave</u>	<u>Tropo</u>	<u>Other</u>
FRC-37	FRC-75	Cable
MW-508D	MRC-80	HF TRC-24
MW-509E	FRC-96	TELPACK
LC-8	FRC-136	SATCOM Terminal
74A2	MRC-98	
HM-510/560	MRC-121	
TRC-180	TRC-66	
TRC-150	FRC-56A	
FRC-109	FRC-39	
LC-4		
FM-120		
FRC-80		
FRC-147		
EM-12/400		
MW-503		
FRC-84		

A3.0 TEST RECOMMENDATIONS

The factors that will have an impact on the design of an experimental imagery dissemination effort in the European theater of operation are discussed in the following paragraphs. Of particular interest are comments on the rules that should be adopted in the planning of a successful experiment for the dissemination of secure imagery through automatic or manual means.

A3.1 Nodal Adjacency

It is very important that the tail connections to nodes or switching centers be minimized in length. The longer the tail, the more corrupt it becomes from the standpoint

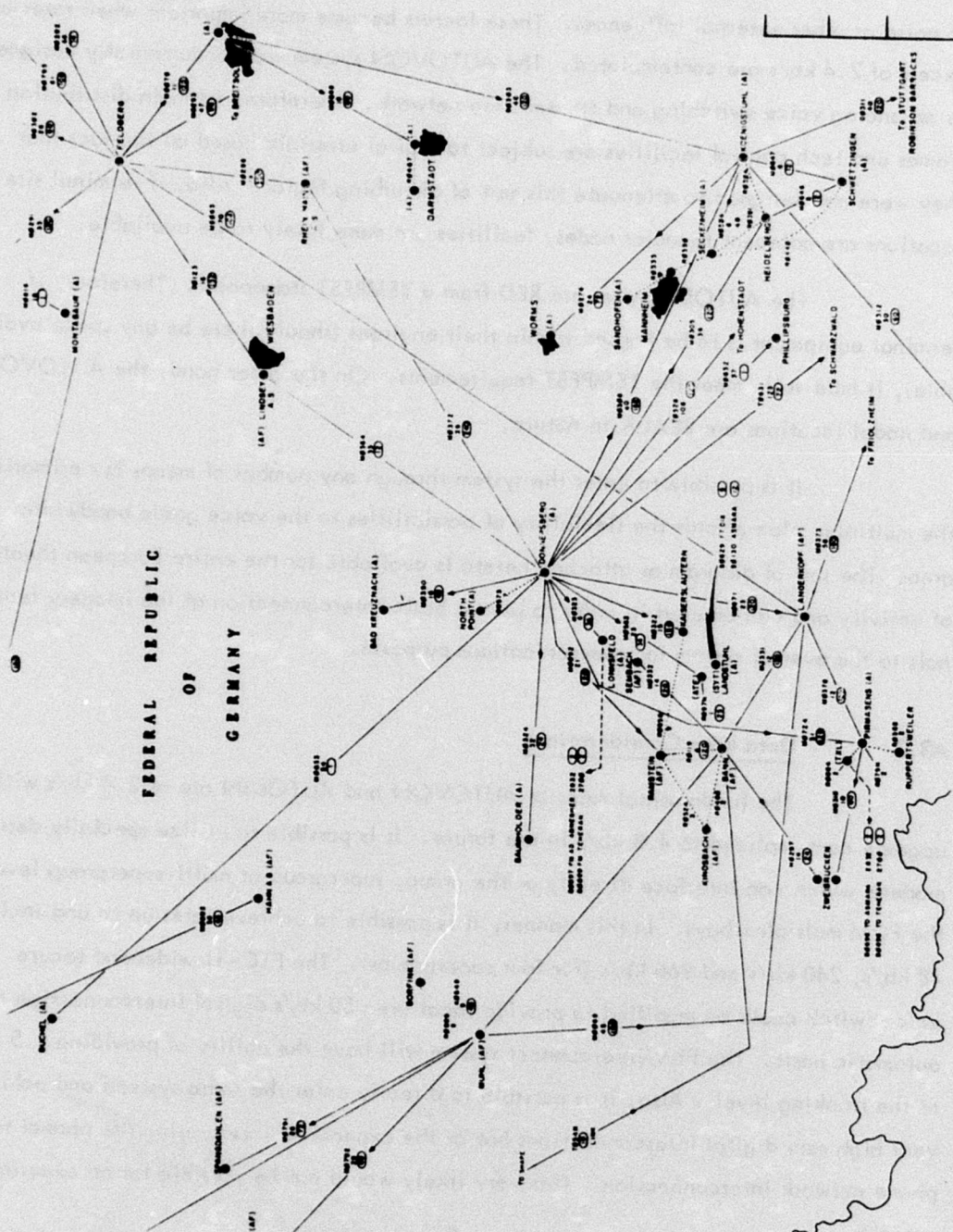

of noise or other external influences. These factors become more important when rates in excess of 2.4 kb/s are contemplated. The AUTOVON system was fundamentally designed as an analog voice switching and transmission network. Therefore, its main distribution frames and tech control facilities are subject to digital crosstalk based on the fact that they were not designed to attenuate this sort of disturbing factor. Also, if terminal site locations are adjacent to major nodes, facilities are more likely to be available.

The AUTODIN sites are RED from a TEMPEST standpoint. Therefore, if terminal equipment is to be housed within their environs (should there be any space available), it must fully meet the TEMPEST requirements. On the other hand, the AUTOVON and nodal locations are BLACK in nature.

It is possible to enter the system through any number of means but primarily the multiplex plan affords the flexibility of possibilities in the voice grade bandwidth area. The sort of diagram as attached hereto is available for the entire European theater of activity and can be used in order to plan a basic interconnection of the imagery terminals to the overall system for communications purposes.

A3.2 Data Rate Considerations

The fundamental rates of AUTOVON and AUTODIN are at 2.4 kb/s with upgrade contemplated to 4.8 kb/s in the future. It is possible to utilize specially designed modems which can interface directly at the group, supergroup or multi-supergroup level at the FDM multiplex bays. In this manner, it is possible to achieve rates up to and including 48 kb/s, 240 kb/s and 960 kb/s (for four supergroups). The FTC-31 wideband secure voice switch could be modified to provide local area 50 kb/s digital interconnection on an automatic basis. The FKV interconnect system will have the ability of providing 1.5 Mb/s at the trunking level. Also, it is possible to directly enter the radio systems and achieve very high rate digital interconnections but at the expense of interrupting the normal telephone network interconnection. This very likely would not be possible for an experimental program.

When the initial TRI-TAC switches are introduced into the European field, it will be possible to obtain trunk capability between 1 and 20 Mb/s and tail capability

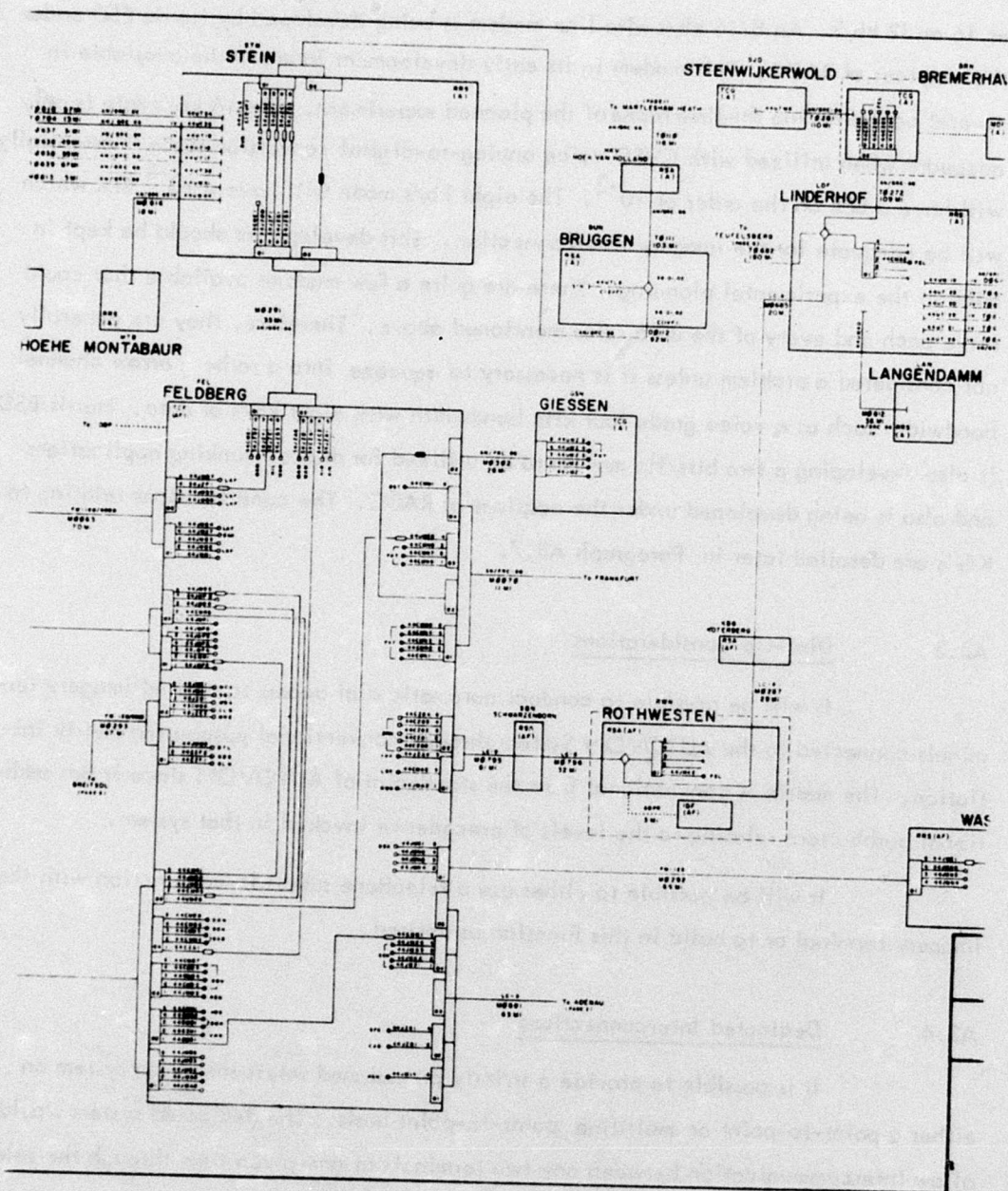

at 16 or 32 kb/s. An 8/16 kb/s wire line modem is being developed by Harris ESD under the auspices of RADC. This modem in its early development form may be available in several copies during the time frame of the planned experiment. The 16 kb/s rate is only adequate when utilized with CVSD voice analog-to-digital conversion since it essentially will have a BER on the order of 10^{-2} . The eight kb/s mode will have a 10^{-5} BER which will be adequate for the imagery interconnection. This development should be kept in mind in the experimental planning. There are quite a few modems available that could serve each and every of the data rates mentioned above. Therefore, they are generally not considered a problem unless it is necessary to squeeze into a rather narrow channel bandwidth such as a voice grade four kHz bandwidth with eight kb/s of data. Harris ESD is also developing a two bits/Hz modem to be utilized for digital trunking applications and also is being developed under the auspices of RADC. The considerations relating to KG's are detailed later in Paragraph A3.7.

A3.3 Dial-Up Considerations

It will be possible to conduct automatic dial access to desired imagery terminals connected to the AUTOVON System through conventional pushbutton matrix initiation. The matrix is conventional from the standpoint of AUTOVON since it has additional pushbuttons relating to the levels of precedence invoked in that system.

It will be possible to either use a telephone subset in conjunction with the imagery terminal or to build in this function as desired.

A3.4 Dedicated Interconnections

It is possible to provide a strictly preassigned interconnection system on either a point-to-point or multiline point-to-point basis. The dedicated system would allow intercommunication between any two terminals at one given time through the selection of the proper dedicated channel by the terminal operators.

A3.5 Operator Intervention

It is possible to provide a manual interconnection for purposes of conducting the imagery dissemination experiment through tech control patching at the nodal or circuit switching centers. This could be operationally adequate for the experiment but would not be amenable to long-term implementation of the theater dissemination system. If the AUTOSEVOCOM is modified and the SEVAC is used, an operator intervention is normally provided for the 50 kb/s interconnections should the terminal operators desire such assistance. This only applies to the case where long-haul narrowband trunking is associated with the 50 kb/s to local service.

In the case of manual PBX operation, an operator can be employed to conduct the interconnection on a requested basis.

A3.6 Certified Facilities/Clearances

Since it is expected that real intelligence imagery will be transferred during the experimental tests in Europe, it will be necessary to have RED facilities from the TEMPEST standpoint. This also implies the use of crypta equipment for protection of intersite connections.

It is essential that any special clearances required for contractor personnel to obtain access to the sites where the terminals are to be utilized must be acquired in plenty of time in order that delays in entry do not disturb the overall experimental test program. We have recently participated in the conduct of tests of the EICS system developed by Harris ESD at Ramstein and Schierstein in the FROG. Careful planning was required in order to ensure the smooth running of those tests.

A3.7 COMSEC Considerations

The AUTOVON System can provide digital interconnection when used with 2.4 kb/s modems. There are a number of contemporary cryptographic equipments that can satisfy this need. Examples are the members of the KG-30 series, the anti-quoted KG-13, the new KG-81 or KG-82, the KG-28, etc. If there is a system need to go

to data rates in excess of 1 Mb/s with the KG-30 series, the HN-74 phasing unit is required. This allows secure operation in excess of the 1.5 Mb/s contemplated for the imagery dissemination terminals.

If the FTC-31 switches are used for local 50 kb/s routing, the same KG's as above could be used after one deletes the KY-3 units from the system. Interswitch narrowband trunking via SEVAC could be accomplished directly with the current KG-13 units operating at 2.4 kb/s.

When the TRI-TAC System is employed in the field, operation will be conducted at 32 or 16 kb/s using the LKG. The TED is generally planned for trunking at either a trunk level or submultiplex level between TRI-TAC switches. However, these units (LKG and TED) could be utilized in other non-TRI-TAC related applications. The TRI-TAC use could only be employed if the experiment was delayed by some time. A ruthless preemption could be employed in that case and up to 20 Mb/s trunks could be utilized if the imagery data were important enough. A current system for interconnecting the U. and S. CINCS is currently employed which utilizes ruthless preemption at 50 kb/s for secure voice conferencing.

A4.0 COMMUNICATIONS TRENDS IMPACTING EUROPE

The evolving communications technology and plans that will affect the dissemination of imagery in the European theater (and elsewhere) are now discussed. Since the actual deployment is a function of the budgetary and political policies of several future administrations, actual dates have no real significance in depicting the evolution. In their place the time periods have been called near future, digital growth explosion and future integrated digital network. A guess for the three periods would be the present to 1985, 1978 to 1995 and 1985 to 2015.

A4.1 DCS-Near Future

This period in the DCS evolution consists of two major thrusts; that is, conversion of transmission paths to digital operation and conversion of switching to time

division techniques. Implementation of the transmission path conversion is currently in progress on a relatively small scale test bed basis and will continue throughout the conversion process. Implementation of the switching hierarchy conversion will start in the near future.

A4.1.1 The FKV Project

This project is being implemented. It involves conversion of selected line-of-sight microwave links in Germany from FDM/FM operation to PCM/TDM/FM operation. The paths connect Frankfurt, Koenigstuhl and Voehingen, thus FKV. It utilizes both commercial and military versions of the Bell System PCM/TDM hierarchy. All analog signals (voice, quasi-analog, data signals, signalling tones, facsimile, etc. are converted to digital signals in a two-step process; i.e., amplitude sampling of the analog signal at an 8 kilosamples per second rate, and quantizing of these samples into 256 levels using an 8-bit word. The eighth bit is also shared as a signalling channel for supervisory signals (on/off hook, etc.). The individual quantized signals are time division multiplexed into a composite signal of 1.544 Mb/s representing the equivalent of 24 voice channels. Data stream users in digital format can also be accommodated in later configurations of this first-level TDM; i.e., digital I/O cards can be substituted for voice channel cards on a one-for-one basis to provide 0-50 kb/s and 56 kb/s asynchronous ports, and 56 and 64 kb/s synchronous ports. The asynchronous ports are accommodated through buffering, bit stuffing and encoding techniques while the synchronous ports are clocked by the TDM.

The second level TDM accepts from two to eight of the first level streams on an asynchronous basis, i.e., each first-level TDM uses an independent internal clock at a nominal 1.544 Mb/s rate. Second level synchronization is accomplished through a combination of buffering and bit stuffing. The composite stream is then converted to a three-level partial response signal and applied to the FM modem of an analog oriented LOS path on a link-to-link basis through conventional receive time recovery techniques. First-level TDM synchronization is via the buffer/bit stuff/unstuff processing. Quasi-analog data users via the PCM voice channel maintains synchronization on an end-to-end

basis; data users, via the digital ports, maintain synchronization through the buffer/bit stuff/encoding processing in the first-level TDM for asynchronous users, and on a master-slave basis for synchronous users with the user slaved to the first level TDM as master.

The beauty of this scheme is that while it permits conversion of transmission links to digital operation with its inherent improvement in performance for both voice and data users it also permits retention of all existing analog voice channel space-division switching and data message store-and-forward switching.

A4.1.2 Project DEB

The next step in transmission path conversion is Project DEB which is a series of phased tasks for further conversion of the European LOS links to digital operation. Although at the time of this writing a final decision has not been made, it appears that early phases will be a refinement of the FKV project. Additional LOS links will be converted to digital operation utilizing the three-level partial response modulation scheme over the FM LOS radio path. However, a Digital Applique Unit (DAU) is being developed which adds considerable capability to the subsystem. In FKV, the binary-to-partial response signal conversion is accomplished as a function of the second-level TDM as is recovery of bit timing interval in the TDM receiver. Radio path diversity combining/switching and hot standby switching are still performed on an analog parameter detection basis at the IF frequency or at the FM baseband. The DAU concept combines the three-level partial response modem, a local clock, diversity switching/combining, receive bit time recovery circuitry, a means of pseudoerror performance monitoring, insertion/removal of digital order wire channels, hot standby switching control, a message stream randomizer and other digital functions in a common facility. It is arranged to be either synchronous on a link-to-link basis with the DAU clock and receive time recovery clock providing timing to the TDM hierarchy, or to operate as a slave to a station master clock which can be an independent clock or a nodal clock in a timing/synchronization subsystem.

The TDM hierarchy will also be refined in order to provide 8,000 n bits per second I/O ports for compatibility with the new 8,000 n bits per second standard data rate users; the TDM will also be arranged to be convertible from the asynchronous bit

stuff mode to a synchronous nonbit stuff mode TDM. These innovations represent good planning in that provisions are made for introduction of synchronous operation at any time period.

Later phases of the DEB project will probably introduce a new digital radio; i.e., one which eliminates the FM modem and substitutes a digital modem at an IF interface. This is known as the DRAMA terminal and includes the multiplex and radio functions. This radio can be operated on a link-to-link synchronous basis or as a slave to an external clock. From the network timing point of view, the new digital radio is similar to the DAU concept except for greater bit rates and some potential improvement in performance in terms of average BER, availability in terms of average BER, and in mean-to-loss of bit count integrity during deep fades. The latter is extremely important in the case of maintaining cryptographic synchronization.

Harris ESD is directly involved in these efforts by our participation with RADC to develop a 70 MHz IF interface digital modem having a 2-bit/Hz bit density at RF, our internal R&D program to develop the DAU, our contract with RADC to develop the concepts and initial units of an 8 kb/s/16 kb/s wire line modem, and our participation with DCA and the Army in developing specifications for the digital radio and conducting a study of the precise time and time interval requirements for the evolving DCS.

A4.1.3 Digital Tropo

Another ongoing project is the development of a digital modem for use with tropospheric scatter radio links. This modem will interface with the same multiplex hierarchy as will the LOS links and be configured to be synchronous on a link-to-link basis or be slaved to an external clock. The primary difference of the digital TROPO link will be the lower grade of performance in terms of bit error rate, bit count integrity, availability due to the more frequent deep, rapid, and dispersive fades and a wider variation in path length due to these fades.

A4.1.4 Bulk Encryption

Another significant change during these efforts is the introduction of bulk encryption; i.e., at various levels in the TDM hierarchy as opposed to encryption on an individual user channel basis. Encryption will also take place on a user channel basis, where required, but all information traversing the digital transmission link will be encrypted on a bulk basis. These bulk cryptodevices will be arranged to receive timing from the modem/TDM hierarchy or from an external clock source. The actual devices devised for this application are the Trunk Encryption Devices (TSEC/KG-81).

A4.1.5 DSCS

The DSCS will also undergo an evolution to synchronous digital link operation. Although the present DSCS links primarily serve unique users requiring wide bandwidths and access to remote areas, the future DCS concept envisions a more extensive utilization of satellite links for intermodal trunks and conversely the terrestrial DCS will provide extensive extension of the satellite channels to users remote from the earth terminal.

The DSCS conversion, in most respects, parallels that of the terrestrial LOS links; i.e., some link conversion on the basis of PCM/TDM/FM and most on the basis of single channel per carrier digital modems. Harris ESD is participating in these efforts with SATCOMA by having developed the PSK and QPSK modems being used in the DSCS terminals. The digital DSCS terminals will also contain a timing distribution capability. On the receive end of a link, buffers will be utilized to accommodate the Doppler effects and path length variations caused by the cyclic satellite pattern. A portion of the satellite transponder will be arranged to provide a frequency or timing beacon, receivable by all earth terminals and traceable to universal time. At the earth terminals, this signal will be used to slave modem and multiplex clocks.

A4.1.6 Introduction of Time-Division Switching

Introduction of time-division switching which is a combination of temporal and spatial switching in conjunction with a supporting time-division multiplex hierarchy forces the issue of synchronous nodes.

In a time-division multiplex/switching environment with bit streams arriving from many diverse sources with varying degrees of connectivity, each incoming bit must be available to enter its assigned timeslot at the specified instant it is required. An ideal system of course with exact time at every node and fixed delays between nodes could easily accommodate this requirement. However, in the real-world environment, these conditions do not exist and there are variations in both time and path delay between nodes and between users and nodes.

Two major DCS programs and one major technical program force this decision; i.e., DCS Secure Voice II, DCS AUTODIN II, and TRI-TAC.

Secure Voice II

Secure Voice II envisions conversion of CONUS users to 8 kb/s operation using voice channel modems for transmission and AUTOVON space division switching modified to accommodate the 8 kb/s quasi-analog signals. However, in overseas locations, during the same period, 16 kb/s secure voice will be introduced in conjunction with a DCS digital time-division switch (this switch may or may not be a configuration of the TRI-TAC switch).

Interface between the CONUS and overseas subsystem will be at a MAROON interface. Somewhat later some of the CONUS AUTOVON switches will be modified to switch the 8 kb/s users on a time-division basis. Also during this period, lower level time-division oriented facilities will appear; e.g., digital PABX and digital access exchange (DAX).

AUTODIN II

AUTODIN II plans not only to provide for computer teleprocessing and record communications for common users but also must provide for absorbing certain dedicated networks such as WWMCCS and SATIN IV. In the initial stages, the CONUS switches will be modified to provide packet switching for several hundred terminals and processors while continuing to provide message store and forward switching to the bulk of its users. Later during this period, time-division circuit switching and multiplexing and lower level time-division oriented concentrators or communications access processors will be introduced in the CONUS AUTODIN II complex. Overseas the conversion plan is similar except for a later schedule and Military ownership versus leased facilities in CONUS.

Another significant change introduced by AUTODIN II is the provision for end user-to-end user encryption through the switched network as opposed to the current user-to-switch, switch-to-switch and switch-to-user encryption. This is significant because the existing synchronization in AUTODIN follows the link-to-link encryption scheme and must also follow the AUTODIN II end-to-end encryption concept.

TRI-TAC

TRI-TAC is the joint Military tactical communication system and, as such, is not part of the DCS. However, the TRI-TAC transmission plan depends on the use of DCS trunks to interconnect some of the TRI-TAC switching, multiplex nodes. The TRI-TAC switch is being designed as a multifunction switch; i.e., it will handle analog voice, digital voice, and data traffic. It is a secure system and utilizes 16/32 kb/s rates for the secure voice. It will provide time-division circuit switching for voice and data and message store and forward switching for record communications. There is no switching hierarchy; i.e., all TRI-TAC switching centers (AN/TTC-39 switches) operate on a lateral basis. However, when connected to a DCS node for transmission trunking, they will appear as a minor node with unique characteristics.

The TRI-TAC switch subsystem consists of subscribers, digital switchboards, encryption devices and the switch, all of which are interconnected via a time-division multiplex hierarchy and, in turn, trunking between switches is via a time-division multiplex family. All of the devices and links within a single switch subsystem are synchronized on the master-slave basis to an atomic standard clock.

The first few TRI-TAC switches will be introduced during the same general period as the limited introduction of Secure Voice II and AUTODIN II time-division switching.

A4.2 The DCS-Digital Growth Explosion

This period consists of all the time between the limited introduction of time-division switching and up to the time at which the DCS is a totally integrated digital switch network. AUTODIN II, Secure Voice II and TRI-TAC time-division switches will be widespread and the great bulk of transmission links will be digital links. Digital subscribers will number in the 30-50,000's and switching nodes will number in the 20-30 range. The switching centers will be well established in a tandem and regional switch hierarchy.

This hierarchy is based on the concept of the tandem switch being a trunking switch serving AUTODIN II regional switches, Secure Voice II digital switches and TRI-TAC switches; i.e., users would not normally home on a tandem switch. The concept also envisions that a tandem switch would always be colocated with a regional switch and include the functions of a major Secure Voice II switch.

The tandem switch thus becomes the DCS major node in that it is the major interface between the backbone trunking subsystem and the time-division centers providing access to that trunking for all users via their respective lower level switching center.

The regional switch center, Secure Voice II switch and TRI-TAC switch then become minor nodes in that they are the interface between the tandem switch (via

digital links of a few feet to many miles) and the next lower level which can consist of users, digital PABX's, DAX, unit level switches (ULS), communications access processors and independent user subsystems. Minor node switches will normally come on two tandem switches to provide link redundancy.

From the present period through this growth period and on into the final period, other digital system conversion efforts may be implemented by others and must be considered since the DCS interfaces with these systems and, indeed, in some cases is highly dependent on them. These systems are, of course, the commercial carrier systems, foreign and domestic, and military systems, other than TRI-TAC, including NATO and other allied forces. Foreign common carriers are embarking on digital conversion plans similar to that of the U.S. carriers although somewhat delayed in implementation schedule.

INTELSAT is moving toward construction of PCM/TDM/QPSK/TDMA links at bit rates of 50-150 Mb/s. These satellite links will operate in a burst mode with precise on-off carrier control at the transmitter. Receivers will have very rapid carrier and timing interval acquisition capabilities and all earth terminal input/output port users must be synchronous with directly related data clocks by a master-slave relationship with the earth terminal.

NATO and Allied Forces interfaces are well documented in the final report of the DOD Committee on Interoperability and much of the specific data is classified. However, in general, these systems are adopting the 8,000 nb/s structure and 16/32 kb/s rates for digital voice; the NATO satellite trunks, now FDM/FM, appear to be headed toward an 8,000 nb/s digital structure upgrade.

This period is truly one of the digital explosion; not only in terms of the DCS but also including all military and commercial systems. The "wired city" concept will appear on military installations as well as in the cities. New local area distribution transmission links, such as optical waveguide, fiber optics, millimeter waveguide and LOS radio will enter the various subsystems.

A4.3 The DCS-Future Integrated Digital Network

This period is conceived to provide a switching, trunking and user access network to provide access for any type of subscriber or subsystem for communications of all types of information within bandwidth constraints to other subscribers or subsystems, within the same community of interest or between communities of interest, on an end-to-end secure basis; the JMTTS Concept.

This period would seem to be easier to accommodate than the previous explosion period. Most, if not all, of the analog facilities will have been converted to digital operation, the myriad of interface problems will have been solved, and growth will have slowed to a more reasonable rate. All of this would be true, if technology would stand still. However, it will not and so the problems presented by this period and those following are predominantly those of future technology and its potential demands and impact on the DCS.

MISSION
of
Rome Air Development Center

RADC plans and conducts research, exploratory and advanced development programs in command, control, and communications (C³) activities, and in the C³ areas of information sciences and intelligence. The principal technical mission areas are communications, electromagnetic guidance and control, surveillance of ground and aerospace objects, intelligence data collection and handling, information system technology, ionospheric propagation, solid state sciences, microwave physics and electronic reliability, maintainability and compatibility.

