

UNCLASSIFIED

AD NUMBER

ADB012981

LIMITATION CHANGES

TO:

Approved for public release; distribution is unlimited.

FROM:

Distribution authorized to U.S. Gov't. agencies only; Test and Evaluation; JUN 1976. Other requests shall be referred to Air Force Rome Air Development Center, RBRP, Griffiss AFB, NY 13441.

AUTHORITY

usaf ltr, 22 jan 1980

THIS PAGE IS UNCLASSIFIED

THIS REPORT HAS BEEN DELIMITED  
AND CLEARED FOR PUBLIC RELEASE  
UNDER DOD DIRECTIVE 5200.20 AND  
NO RESTRICTIONS ARE IMPOSED UPON  
ITS USE AND DISCLOSURE.

DISTRIBUTION STATEMENT A

APPROVED FOR PUBLIC RELEASE;  
DISTRIBUTION UNLIMITED.

ADBOI2981

RADC-TR-76-174  
Final Technical Report  
June 1976



EVALUATION OF ADHESIVES FOR HYBRID MICROCIRCUITS

Martin Marietta Corporation

Distribution limited to U.S. Gov't agencies only;  
test and evaluation; June 1976. Other requests for  
this document must be referred to RADC (RBRP),  
Griffiss Air Force Base, New York 13441.

AD No. \_\_\_\_\_  
DDC FILE COPY

ROME AIR DEVELOPMENT CENTER  
AIR FORCE SYSTEMS COMMAND  
GRIFFISS AIR FORCE BASE, NEW YORK 13441

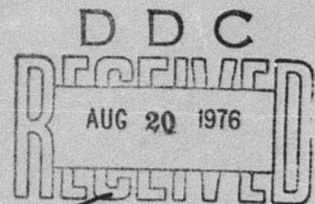

*JG*  
A

This report has been reviewed and is approved for publication.

APPROVED: *Alfred L. Tamburrino*  
ALFRED L. TAMBURRINO  
Project Engineer

APPROVED: *Joseph J. Naresky*  
JOSEPH J. NARESKY  
Chief, Reliability & Compatibility Division

FOR THE COMMANDER: *John P. Huss*  
JOHN P. HUSS  
Acting Chief, Plans Office

Do not return this copy. Retain or destroy.

*MISSION*  
*of*  
*Rome Air Development Center*

RADC is the principal AFSC organization charged with planning and executing the USAF exploratory and advanced development programs for information sciences, intelligence, command, control and communications technology, products and services oriented to the needs of the USAF. Primary RADC mission areas are communications, electromagnetic guidance and control, surveillance of ground and aerospace objects, intelligence data collection and handling, information system technology, and electronic reliability, maintainability and compatibility. RADC has mission responsibility as assigned by AFSC for demonstration and acquisition of selected subsystems and systems in the intelligence, mapping, charting, command, control and communications areas.



REPORT DOCUMENTATION PAGE		READ INSTRUCTIONS BEFORE COMPLETING FORM	
1. REPORT NUMBER <b>18</b> RADC-TR-76-174	2. GOVT ACCESSION NO.	3. RECIPIENT'S CATALOG NUMBER	
4. TITLE (and Subtitle) <b>6</b> EVALUATION OF ADHESIVES FOR HYBRID MICROCIRCUITS		5. TYPE OF REPORT & PERIOD COVERED <b>9</b> Final Technical Report, October 1975	
7. AUTHOR(s) <b>10</b> R. A. Homan		6. PERFORMING ORG. REPORT NUMBER <b>14</b> MCR-75-394	
9. PERFORMING ORGANIZATION NAME AND ADDRESS Martin Marietta Corporation P. O. Box 179 Denver CO 80201		8. CONTRACT OR GRANT NUMBER(s) <b>15</b> F30602-73-C-0149 <i>new</i>	
11. CONTROLLING OFFICE NAME AND ADDRESS Rome Air Development Center (RBRP) Griffiss AFB NY 13441		10. PROGRAM ELEMENT, PROJECT, TASK AREA & WORK UNIT NUMBERS <b>17</b> 735066 <b>16</b> AF-7350 55190636	
14. MONITORING AGENCY NAME & ADDRESS (if different from Controlling Office) Same		12. REPORT DATE <b>11</b> Jun 76	
		13. NUMBER OF PAGES <b>13</b> 14p.	
		15. SECURITY CLASS. (of this report) UNCLASSIFIED	
		15a. DECLASSIFICATION/DOWNGRADING SCHEDULE N/A	
16. DISTRIBUTION STATEMENT (of this Report) Distribution limited to U.S. Gov't agencies only; test and evaluation: June 1976; Other requests for this document must be referred to RADC (RBRP), Griffiss Air Force Base, New York 13441.			
17. DISTRIBUTION STATEMENT (of the abstract entered in Block 20, if different from Report) Same			
18. SUPPLEMENTARY NOTES RADC Project Engineer: Alfred L. Tamburrino			
19. KEY WORDS (Continue on reverse side if necessary and identify by block number) Epoxy Adhesives                      Microelectronics Adhesive bond evaluation          Hybrid circuit bonds Substrate bonding                    Thermogravimetric analyses Chip bonding			
20. ABSTRACT (Continue on reverse side if necessary and identify by block number) An evaluation of the use of adhesives in microcircuits was performed. Ten adhesives were subjected to physical properties analyses including TGA-RCA testing. Four of these adhesives having significant industry use were further used in the fabrication of hybrid test circuits. The circuits utilized a power transistor and a MOSFET transistor for evaluation of thermal/electrical and contamination/outgassing effects. Control samples using only eutectic bonds were also fabricated. High temperature storage, power burn-in, power cycling, thermal shock, mechanical shock, centrifuge, and seal tests were			

403225

over

687

UNCLASSIFIED

SECURITY CLASSIFICATION OF THIS PAGE(When Data Entered)

performed. Selected survivors of each adhesive test group were subjected to extended power cycling (50,000 cycles) or thermal shock tests (-200°C to +300°C). Failure analyses, thermal conductivity tests, gas analyses, and die shear tests were also performed.

No adverse results in the areas of mechanical bond strength, surface contamination effects on the MOSFETs, or contamination effects on hybrid assembly processes were identified from the use of these adhesives for chip bonding. Electrical and thermal conductivities were decreased as compared to eutectic bonds. Epoxy bonds that failed were limited to bonds between ceramic substrates and metal packages. Bonds that survived the initial environmental tests also survived the extended tests.

The evaluation indicated that the adhesives tested are viable candidates for use as chip attach in high reliability applications.

UNCLASSIFIED

SECURITY CLASSIFICATION OF THIS PAGE(When Data Entered)

PREFACE

This document is an update of report MCR-74-139 prepared for Rome Air Development Center under Contract F30602-73-C-0149. This updated version includes the results of additional testing and analyses recently performed on the circuits fabricated for this study in 1973. The initial report MCR-74-139 was prepared by Mr. R. D. Boblitt for work performed under the direction of Mr. R. F. Peluso.

APPROVED FOR	
NTIS	White Section <input type="checkbox"/>
DOC	Buff Section <input checked="" type="checkbox"/>
UNANNOUNCED	<input type="checkbox"/>
JUSTIFICATION.....	
BY.....	
DISTRIBUTION/AVAILABILITY CODES	
Dist.	AVAIL. and/or CONTROL
B	

## CONTENTS

		<u>Page</u>
Section I	INTRODUCTION . . . . .	1
	Technical background . . . . .	1
	Objectives . . . . .	2
	Approach . . . . .	2
Section II	PHASE 1, VENDOR SURVEY AND PRELIMINARY DATA EVALUATION . . . . .	5
Section III	PHASE 2, POLYMER EVALUATION TESTS . . . . .	9
	TGA-RGA tests in a vacuum . . . . .	9
	Final polymer selections . . . . .	12
	TGA-DTA tests in nitrogen . . . . .	13
	Vacuum outgassing and weight loss . . . . .	26
	Thermal conductivity tests . . . . .	27
	Ion and conductance tests . . . . .	29
	Dimensional stability . . . . .	29
Section IV	PHASE 3, PROCESSING EVALUATION . . . . .	31
	Lap shear strength . . . . .	31
	Electrical conductivity . . . . .	31
	Shelf life . . . . .	33
	Repairability-handling . . . . .	33
	Effect of adhesives on wire bonding and hermetic sealing . . . . .	34
Section V	PHASE 4, HYBRID TESTING . . . . .	35
	Test specimens description . . . . .	35
	Failure Analysis . . . . .	52
	Analysis method and disclosure . . . . .	53
Section VI	PHASE 5, DEVICE PROPERTY EVALUATION . . . . .	61
	Thermal conductivity . . . . .	61
	Gas analysis . . . . .	62
Section VII	ADDITIONAL TESTING . . . . .	65
	Vidicon examination . . . . .	65
	Electrical measurements . . . . .	65
	Power cycling parts . . . . .	66
	Additional failure analysis . . . . .	67
	Die shear tests . . . . .	70
Section VIII	CONCLUSIONS AND RECOMMENDATIONS . . . . .	71

## FIGURES

FIGURE 1.	Standard questionnaire to suppliers . . . . .	6
2.	Ablestick 535 adhesive . . . . .	14
3.	Ablefilm 517 adhesive . . . . .	15
4.	Epotek H-31 adhesive . . . . .	16
5.	duPont 5504 adhesive . . . . .	17
6.	Ablestick 535 Arrhenius relation in nitrogen . . . . .	18
7.	Arrhenius relation in nitrogen for Ablestick 535 . . . . .	19

FIGURE 8.	Ablefilm 517 adhesive, Arrhenius relation in nitrogen . . . . .	20
9.	Arrhenius relation in nitrogen for Ablefilm 517 . . . . .	21
10.	Epotek H-31 adhesive, Arrhenius relation in nitrogen . . . . .	22
11.	Arrhenius relation in nitrogen for Epotek H-31 . . . . .	23
12.	duPont 5504 adhesive, Arrhenius relation in nitrogen . . . . .	24
13.	Arrhenius relation in nitrogen for duPont 5504 . . . . .	25
14.	Temperature drop in thermal conductivity measurement . . . . .	28
15.	Test flow diagram . . . . .	36
16.	MOSFET 3N167 . . . . .	37
17.	Power transistor T.I. 2N2987 . . . . .	38
18.	Hybrid package used in testing . . . . .	39
19.	Burn-in and power cycling test circuit . . . . .	46
20.	Electrical measurements . . . . .	49
21.	S/N 125 group 5, magnification 50X . . . . .	54
22.	S/N 125 group 5, magnification 5X . . . . .	57
23.	S/N 125 group 5, magnification 5X . . . . .	57
24.	Simplified model of a hybrid equivalent . . . . .	59
25.	Rattler preform and substrate, S/N 136 . . . . .	68
26.	Rattler preform, rear view, S/N 136 . . . . .	68
27.	Rattler case, S/N 136 . . . . .	69
28.	Die shear test . . . . .	70

TABLES

TABLE 1.	Evaluation of adhesive for hybrid microcircuits	
	TGA-RGA screening results (tests in vacuum) . . . . .	10
2.	TGA-DTA nitrogen flow test . . . . .	13
3.	Vacuum outgassing and weight loss . . . . .	27
4.	Thermal conductivity . . . . .	29
5.	Specific ions and ion conductance . . . . .	30
6.	Cure and aging shrinkage . . . . .	30
7.	Process evaluation lap shear data . . . . .	32
8.	Test data summary . . . . .	43
9.	Hybrid testing summary . . . . .	48
10.	Retest data for 2N2987 transistor . . . . .	55
11.	Pulse level $\theta_{JC}$ in $^{\circ}\text{C}/\text{watt}$ . . . . .	56
12.	$\theta_{JC}$ measurements . . . . .	62
13.	Gas analysis of hermetically sealed packages, 1st test . . . . .	64
14.	Gas analysis of hermetically sealed packages, 2nd test . . . . .	64
15.	Additional measurements . . . . .	66
16.	Power cycling parts . . . . .	67

## EVALUATION

The polymer adhesive for semiconductor chip and substrate attach has some advantages over conventional eutectic methods primarily for hybrid parts (where repair is facilitated) but also for other applications, e.g. where the temperature of eutectic attach causes damage to sensitive chips, or where no eutectic attach method is available, as in silicon on sapphire technology. The reliability of polymer adhesive are generally outlawed in Mil-M-38510, as the result of several proven and suspected failure mechanisms.

The present study of several typical adhesives has shown that there is considerable merit in these materials, and that reliability need not be sacrificed if polymer adhesives are carefully selected, evaluated, controlled and appropriately applied.

The results of this study will be added to a substantial body of data on epoxy die attach reliability from studies by other DOD agencies as well as industry and NASA which indicate that there is an acceptable place for these materials in high reliability microelectronics.

*Alfred L. Tamburrino*

ALFRED L. TAMBURRINO  
Project Engineer

## SECTION 1

### INTRODUCTION

#### Technical Background

Polymer adhesives have been used in microelectronic circuits for a number of years, and it is apparent that the technology will continue to be used in future years. Although circuits employing adhesives have been primarily used in commercial applications, they have also been used in DOD/NASA applications to some degree. The lack of significant physical or chemical data, as well as specific reliability history concerning adhesive-bonded circuits, has restrained usage in the latter applications.

Adhesives commonly used in hybrid microcircuits fall into two general categories--conductive and nonconductive. The conductive materials are generally used for chip-to-substrate bonding where the bottom of the chip is electrically active, such as a transistor collector. These materials are made electrically conductive by adding fine metal particles, usually gold or silver. The polymer resin is usually an epoxy formulated to hold the particles in suspension. Nonconductive adhesives are used in chip-to-substrate bonds where thermal or electrical conductivity to the bottom of the chip is unnecessary, or in substrate-to-package bonding. The nonconductive materials are polymer resins, either without a filler, or with a ceramic powder filler, added for increasing thermal conductivity and improving thixotropic properties.

There are definite advantages in the use of adhesive bonding in place of eutectic bonding in microelectronic circuits. Most of the advantages are in processing, and they become much more significant when applied to hybrid circuits. Adhesive chip bonding is done at a much lower temperature than eutectic bonding, which reduces possible thermal degradation of semiconductor elements, especially in the case of multi-chip hybrids that must be subjected to eutectic temperatures for extended periods of time. Rework of hybrids is greatly enhanced with adhesive bonding, primarily because a chip is removed and replaced at a lower temperature than with eutectic bonding, and this lessens the chance of degrading wire bonds.

There are disadvantages in using adhesive bonding in hybrid microcircuits. Thermal and electrical conductivity of these materials, even with gold or silver fillers, is somewhat less than that of eutectic materials. Polymer materials are much less stable at elevated temperature than eutectic materials. They typically release loosely held substances such as water, plasticizers, and solvents at lower temperatures, and since the stoichiometry of epoxy systems is never perfect, some portion of the resin or catalyst is always available for outgassing and redeposit at elevated temperatures. These outgassing materials may cause processing problems in hermetic sealing of packages because of excessive internal pressure during solder melt, and because of polymer contaminants causing a reduction of wetting on the seal surface. The

process problems can be overcome relatively easily by carefully controlling seal time/temperature for solder, or by using weld seal techniques that localize the heat at the seal. Of more fundamental importance is the effect of these outgassing products on functional properties of semiconductor elements, particularly under long-term exposure to high temperature. It is possible for these outgassed materials to be corrosive to metallization, or to cause excessive electrical leakage on high impedance circuits because of surface contamination.

### Objecti

The objective of this study was to evaluate the use of polymer adhesives in microelectronics in both chip-to-substrate and substrate-to-package applications. Data generated from this evaluation were applied toward an assessment of the advisability of using such adhesives in high reliability microcircuits to determine which polymer testing techniques are meaningful in determining polymer microcircuit performance, and to modify existing military specifications to implement use of polymers in microcircuits.

### Approach

Vendor Survey - Hybrid and monolithic microcircuit manufacturers were surveyed to determine the type of chip adhesives commonly used, to identify significant success and failures experienced with their use, and to identify specific processing criteria or precautions used to obtain a good product. Adhesive vendors were also surveyed to obtain reliability data and to identify the major microelectronic users of their products. Using survey results and data from the MMC Skylab Hybrid studies, the MMC Program Manager and the MMC Technical Advisory Group selected ten adhesives for study and testing.

Polymer Evaluation Tests - Chemical and physical properties of the selected adhesives were ascertained using combinations of techniques MMC successfully employed for a large number of polymeric materials in the Viking Mars Lander Project. The tests employed were thermogravimetric analysis (TGA), differential thermal analysis (DTA), residual gas analysis (RGA), quartz crystal microbalance weight loss, shrinkage, thermal conductivity, and specific ion determination. The TGA in vacuum was used as an initial screen to reduce the number of evaluated adhesives. This number was reduced from ten to four.

Processing Evaluation Tests - These tests evaluated the processing characteristics of adhesives to determine their suitability for hybrid fabrication techniques and the effect of processing changes on adhesive reliability. A lap shear specimen using gold-plated Kovar adherents with a 0.1-inch square bond area was used as the evaluation mechanism. Lap shear strengths after various temperature storage and thermal cycles were evaluated. The effect of thickness on electrical conductivity was studied. Shelf life of six months was evaluated with respect to mechanical properties. Repairability using each candidate adhesive and its wetting properties was evaluated by observation during sample preparation. Detrimental effects of epoxy on wire bonding and hermetic sealing were examined.

Hybrid Testing - A hybrid test vehicle was designed containing power transistors to evaluate thermal and electrical conductivity and MOSFETS that are sensitive to surface contamination. Test vehicles were made using each of the epoxy adhesives. Equivalent test vehicles were made using eutectic attachment for comparison. Some were sealed in welded packages and some in brazed packages to evaluate the effect of sealing technique on adhesive performance. Critical parameters measured were  $V_{CE(SAT)}$  on the power transistors and  $I_{GSS}$  on the MOSFET. These parameters were measured at the start of testing and after each test environment such as power burn-in, power cycling, mechanical shock.

Device Property Evaluation - A hybrid test vehicle representing each adhesive/package type was evaluated for junction to case thermal impedance  $\theta_{JC}$ . The circuit was scanned with a microradiometer while under power to establish thermal profile. After hybrid testing was completed, representative samples of hybrid test vehicles were analyzed at RADC for internal gas composition using mass spectrometer analysis.

## SECTION II

### PHASE 1, VENDOR SURVEY AND PRELIMINARY DATA EVALUATION

Between 12 February and 23 March 1973, 27 users of adhesives in hybrid microcircuits were surveyed to determine (1) which adhesives they were using; (2) special process criteria and precautions employed; (3) what applications were successful; (4) application problems; (5) reliability data available; and (6) their recommendations for modifications to MIL screen tests.

The survey was conducted primarily by telephone; some users preferred to fill out the standard questionnaire (Figure 1).

Most hybrid circuit manufacturers surveyed declined to reveal any detailed process information because of proprietary considerations. Of those who did respond, the majority use the epoxy manufacturers' recommended storage, mixing, and curing procedures. The following materials and their uses were discussed in some detail:

- 1) Ablestick 20-1 - used by one manufacturer, screen printed, for die bonding.
- 2) Ablefilm 517 - used by three manufacturers for substrate bonding; used by two manufacturers for die bonding.
- 3) Ablestick ECF535 - used by one manufacturer for chip resistor and capacitor bonding.
- 4) duPont 5504A - used by three manufacturers for die bonding.
- 5) Epotek H-31 - used by two manufacturers for die bonding (one particularly for CMOS IC bonding).
- 6) Epotek H-72 - used by one manufacturer for package sealing (application method not specified).
- 7) Transcene Ohmex - used by two manufacturers for die bonding.

Little of the basic material property-reliability information that might have been accrued during in-house epoxy evaluation was readily available. Either this information was not available to the persons surveyed, or it was considered highly proprietary. A wide variety of processing related tests were discussed, e.g., chip push test, chip bond accelerated aging, outgassing evaluation with high impedance active devices (MOSFETs), and miscellaneous mechanical strength tests. Most hybrid circuit manufacturers evaluate epoxy properties by simulation of actual usage conditions, without accumulating data on basic properties such as outgassing rates and elements, thermal conductivity, and microadhesion.

COMPANY \_\_\_\_\_

PHONE ( \_\_\_\_\_ ) \_\_\_\_\_

NAME \_\_\_\_\_

HYBRID & MONOLITHIC MICROCIRCUIT MANUFACTURERS  
POLYMER ADHESIVE BONDING SURVEY

- I. Using adhesive bonding?
  - A. Chip bonding
  - B. Substrate bonding
  - C. Conductive adhesive
  - D. Nonconductive adhesive
  - E. Manufacturer
  - F. Type designation(s)
  
- II. Special process criteria and precautions
  - A. Polymer storage conditions
  - B. Chip, substrate and package surfaces
    - 1. Type limitations
    - 2. Special preparation
  - C. Polymer application method(s)
  - D. Polymer cure
    - 1. Manufacturer
    - 2. Special
  - E. Subsequent process limitations
  - F. Polymer composition assurance
    - 1. Receiving inspection
    - 2. Lot acceptance testing
  - G. Bond property evaluation
    - 1. Mechanical
    - 2. Thermal
    - 3. Electrical
  - H. Miscellaneous assurances
    - 1. Visual inspection
    - 2. X-ray inspection
    - 3. Other
  
- III. Successful past and present applications
  - A. Circuits built for:
  - B. Performance requirements
    - 1. Electrical
    - 2. Environmental
  - C. Reliability requirements

Figure 1. Standard questionnaire to suppliers  
(spacing closed up for example).

- IV. Problems in past and present applications
  - A. Circuits built for:
  - B. Performance requirements
  - C. Failure analysis
    - 1. Failure type
    - 2. Reasons
    - 3. Solution
  
- V. Reliability data (via letter response)
  - A. Accelerated life test data
  - B. Real life test data
  - C. Other reliability related information
  
- VI. Recommendations
  - A. Modifications to MIL screen tests
  - B. Special acceptance tests
  - C. Usage limitations

Figure 1. (concluded).

A meeting of the Technical Advisory Group was held on 1 March 1973 to select the materials to be evaluated in the initial screen using thermogravimetric analysis. Ten materials were selected for this initial list:

- 1) Ablestick 20-1, silver filled epoxy paste;
- 2) Ablestick 150-6, solvent thinned epoxy primer;
- 3) Ablefilm 517, glass epoxy film;
- 4) Ablestick ECF535, silver filled epoxy film;
- 5) duPont 5504-A, silver filled epoxy paste;
- 6) Epotek H-31, silver filled epoxy paste;
- 7) Epotek H-41, gold filled epoxy paste;
- 8) Epotek H-72, alumina filled epoxy paste;
- 9) Epotek H-74, alumina filled epoxy paste;
- 10) Transcene Ohmex, silver filled epoxy paste.

## SECTION III

### PHASE 2, POLYMER EVALUATION TESTS

The chemical and physical properties of the ten representative adhesives chosen during the vendor survey phase were determined. Vendor recommended cure times and temperatures were used in preparing the test specimens. The tests commenced in March 1973 and were completed in July 1973. Each of the ten adhesives were subjected to thermogravimetric analysis (TGA) and residual gas analysis (RGA). Based upon results of these two tests, the number of adhesive materials for complete evaluation was reduced to four. The four adhesive test specimens were subjected to the following tests:

- 1) TGA-RGA tests in vacuum;
- 2) TGA-DTA tests in nitrogen;
- 3) Vacuum outgassing and weight loss tests;
- 4) Thermal conductivity tests;
- 5) Specifications and conductances tests;
- 6) Dimensional stability.

#### TGA-RGA Tests in a Vacuum

The thermochemical behavior of the ten selected polymer test specimens in a vacuum was determined using established TGA test techniques. The temperature of a 10-mg sample of each polymer was increased at a programmed rate of 10°C/min until 600°C was reached. The weight-loss-temperature relationship was recorded. Every 12°C during the programmed temperature increase, a mass spectrometer sampled the effluent gases. Hence, the weight and nature of the outgassing products were determined.

The TGA and RGA data are shown in Table 1. The percent of weight loss at each indicated temperature is given as absolute weight loss based on the total weight of sample, and as adjusted weight loss based on weight of resin in sample. Since the exact amount of resin present was not known, it was assumed to be the weight loss at 600°C. This is not completely accurate because there is some residual resin ash at 600°C, but the amount of error is very small and does not affect the comparative data.

The TGA data show that the materials cured for relatively long times and at relatively high temperatures have significantly lower weight loss than those materials cured at lower temperature and less time. The RGA data show definite evidence of boron trifluoride activator in Epotek H-31 and H-41 material. Mass numbers 19(F), 30(BF), 49(BF<sub>2</sub>), and 68(BF<sub>3</sub>) are all present.

TABLE 1. EVALUATION OF ADHESIVE FOR HYBRID MICROCIRCUITS  
TGA-RGA SCREENING RESULTS (TESTS IN VACUUM)

Material	H-31	H-41	H-74 H-72	5504
Manufacturer	Epotek	Epotek	Epotek	duPont
Filler	Ag	Au	100A38 None	Ag
Temperature °C/ Cure hours	150 1/2	150 1/4	100 1/3	160 16
Weight loss starts, °C	75	55	80	140
Weight loss at 125°C, % Resin Sample	0.46 0.11	1.31 0.10	0.57 0.14	0 0.0
Weight loss at 180°C, % Resin Sample	1.36 0.33	2.49 0.19	0.93 0.23	0.36 0.056
Weight loss at 210°C, % Resin Sample	1.83 0.44	3.14 0.24	1.01 0.25	0.76 0.12
Sample weight loss at 600°C, %	24.1	7.61	24.8	15.73
Outgassing at 12°C M/E	18,27,28,30, 32,40,44. Trace of 45,55,56.	18,28,30, 32,40,44, and 19.	18,28,32, 40,44. Trace of 45,50,51.	18,28,32, 40,44. Trace of 50,55,57.
Outgassing at 180°C M/E	14,18,27,28, 30,32,40,44. Trace of 45.	14,18,28, 30,32,40, 44,19.	14,18,28, 40,44.	14,18,28, 32,40,44.

TABLE 1. (concl)

Ohmex	150-6 Primer	20-1	535	517
Transcene	Ablestick	Ablestick	Ablestick	Ablefilm
Ag	None	Ag	Ag	Glass cloth
150 15	R.T. 1 hr 170 1 hr	121 1	150 1	221 1/2
160	60	145	55	75
0 0.0	0.42 0.38	0 0.0	0.42 0.12	0.12 0.07
0.30 0.05	0.42 0.38	1.40 0.246	1.10 0.32	0.21 0.12
0.60 0.10	0.45 0.41	3.01 0.53	1.39 0.40	0.32 0.18
16.7	91.5	17.6	28.7	56.8
18,28,32,40, 44.	18,28,30, 32,40,44. Trace of 50.	18,27,29,30, 32,40,44. Trace of 45,50,55.	14,16-18,28, 30,32,40,44. Trace of 45,51.	14,16-18,27, 28,30,32,40, 42,44. Trace of 55,71,72.
14,16-18,28, 30,32,40,44. Trace of 45, 50.	14,18,27,28, 30,32,40,44. Trace of 45, 50,55,56.	14-18,27,28, 30,32,40,44, 50. Trace of 45,47,49,51, 52,55,56.	Same as at 125°C	Same as at 125°C

To evaluate the effects of all ten selected materials on the aluminum metalization of microelectronic devices, the following test was devised and performed.

Ten samples of 5-mil Mylar approximately 2 x 2 inches square were coated with aluminum via vacuum deposition. This is the same method used in inter-connecting various electrical functions on microelectronic devices. The thickness of the aluminum on the test samples was approximately 100 microinches. The adhesive materials were mixed as prescribed by the Vendors and a gram of each material was placed on each sample of aluminized Mylar. The surface area covered was 2 cm<sup>2</sup>.

After 24 hours, the H-31 and H-41 material had dissolved the aluminum from the Mylar. The other samples were unaffected.

Analysis of the results indicates that TGA-DTA-RGA tests: (1) provide a good evaluation of thermal stability, (2) provide a good process evaluation tool, and (3) generate useful activation energy information for thermal decomposition.\*

#### Final Polymer Selections

At a meeting of the Technical Advisory Group, held 19 April 1973, four materials were chosen for further evaluation. These were:

- 1) Epotek H-31, silver filled epoxy paste
- 2) duPont 5504-A, silver filled epoxy paste
- 3) Ablestick ECF535, silver filled epoxy film
- 4) Ablefilm 517, glass epoxy film

Each of these materials has significant use in industry. A material having boron trifluoride activator was purposely chosen so that this controversial activator could be evaluated. The two silver filled pastes represent a long time, high temperature cure and a short time, low temperature cure material so that the relative merits of these classes of resins and activators could be compared. The conductive and nonconductive films were chosen because they represent types of material that are widely used, especially in high volume production. The gold-filled paste was not chosen because of its limited usage in industry.

---

\*H. A. Papazian: "Prediction of Polymer Degradation Kinetics at Moderate Temperatures from TGA Measurement." *J. of A. Polymer Science* Vol 16, pp 2503-2510, 1972.

### TGA-DTA Tests in Nitrogen

The four polymer test specimens were subjected to the TGA-DTA tests in the presence of 5.2 liters per hour nitrogen. The TGA procedure was the same as previously described. The differential thermal analysis (DTA) portion of the test is run concurrently with and uses the same samples as the TGA portion. A reference crucible and a crucible containing the test sample are heated together; the temperature of each crucible is measured. The reference crucible material is inert; thus, a temperature difference between the two crucibles indicates that the test sample has undergone either an exothermic (higher temperature) or endothermic (lower temperature) reaction. The activation energies for thermal degradation and temperature-time exchange factors for accelerated aging tests were computed for each of the materials. The percentage weight loss in the TGA-DTA tests was calculated against total sample and total resin weight as before.

For the four final test materials, a summary of the TGA-DTA (5.2 liters per hour nitrogen flow) test data is presented in Table 2. The time at 180°C that is equivalent to aging the indicated hours at 125°C is also shown; these data were used in Phase 4 in the accelerated aging tests. These accelerated aging times were calculated using the TGA data graphically. The DTA plots in Figures 2 through 5 show no significant exotherms below approximately 300°C. Figures 6 through 13 were utilized for the determination of activation energies and acceleration factors listed in Table 2.

TABLE 2. TGA-DTA NITROGEN FLOW TEST

Material	Ablestick 535	Ablefilm 517	Epotek H-31	duPont 5504
Weight loss starts, (°C)	55	160	50	210
Weight loss at 125°C, (percent)	0.45	0.0	0.13	0.0
Resin loss at 125°C, (percent)	1.48	0.0	0.40	0.0
Weight loss at 180°C, (percent)	0.56	0.01	0.23	0.0
Resin loss at 180°C, (percent)	1.85	0.02	0.71	0.0
Weight loss at 210°C, (percent)	0.61	0.07	0.39	0.0
Resin loss at 210°C, (percent)	2.04	0.14	1.19	0.0
Weight loss at 500°C, (percent)	23.2	46.4	18.4	14.4
Initial activation energy, (Kcal)	19.0	36.9	22.8	26.9
Time at 180°C equivalent aging to 100,000 hr at 125°C, (hr)	5400	345	3000	1600
Time at 125°C equivalent aging to 132 hr at 180°C	2450	38,000	4400	8200
Figure	6	8	10	12

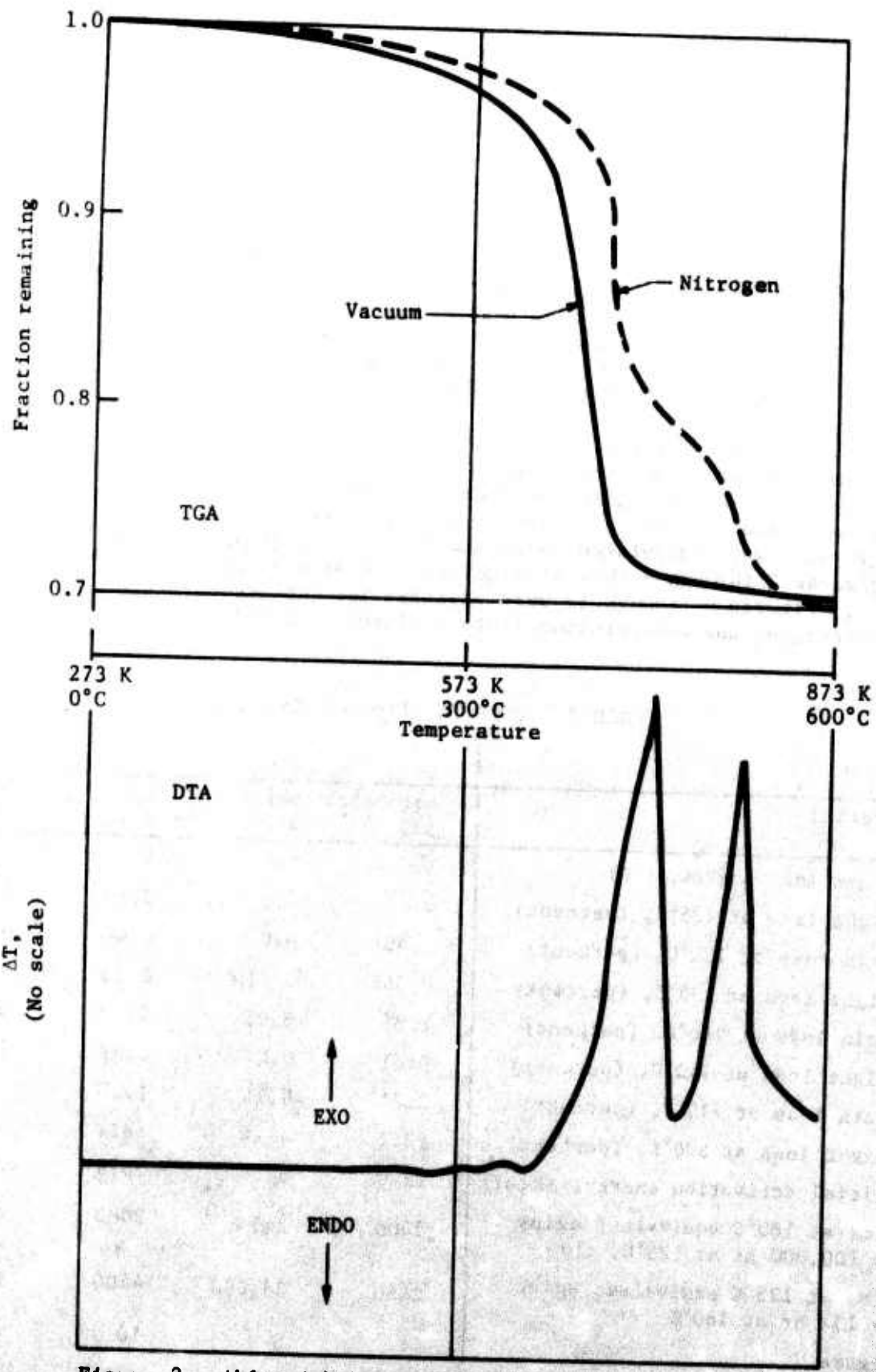

Figure 2. Ablestick 535 adhesive.

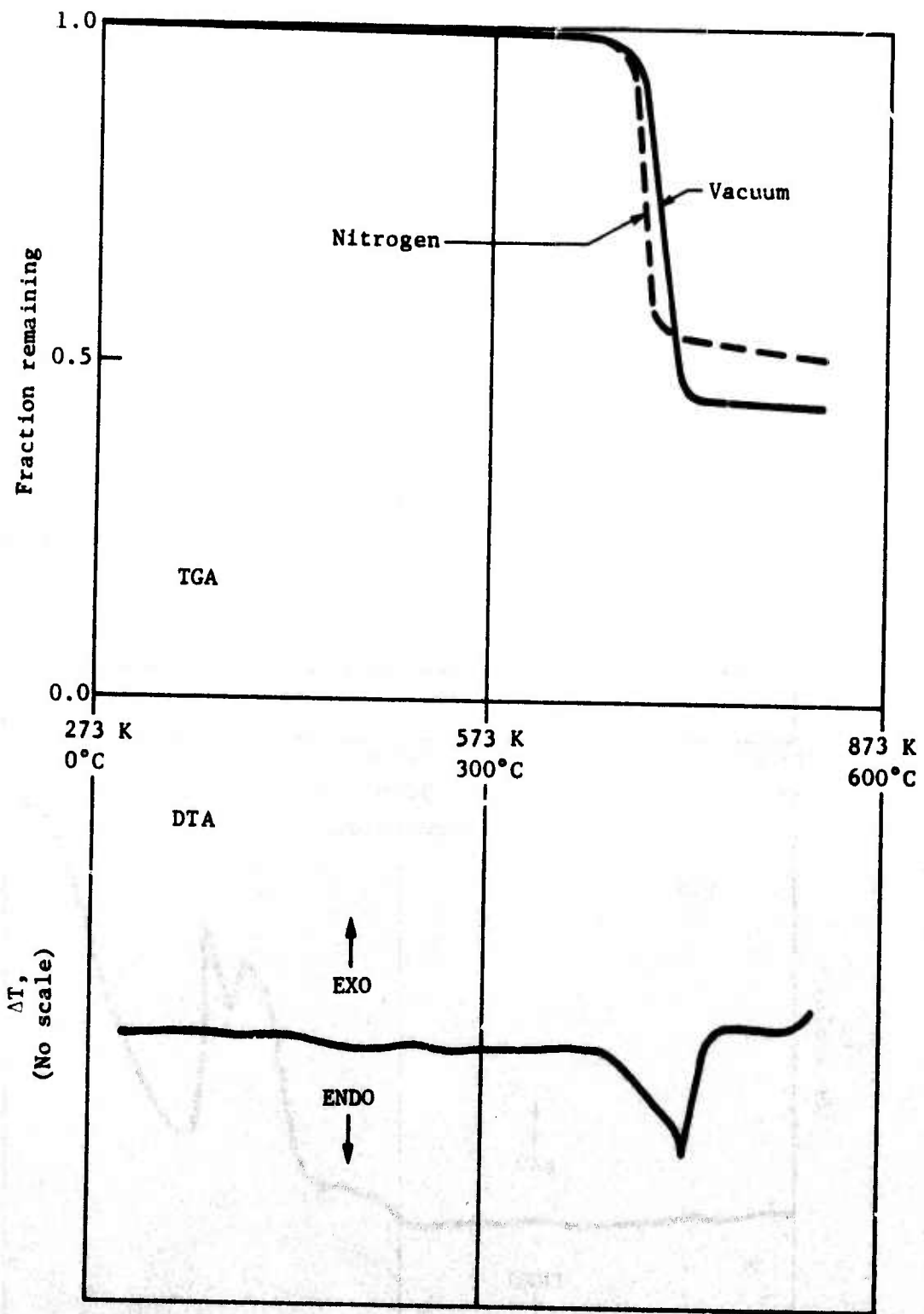

Figure 3. Ablefilm 517 adhesive.

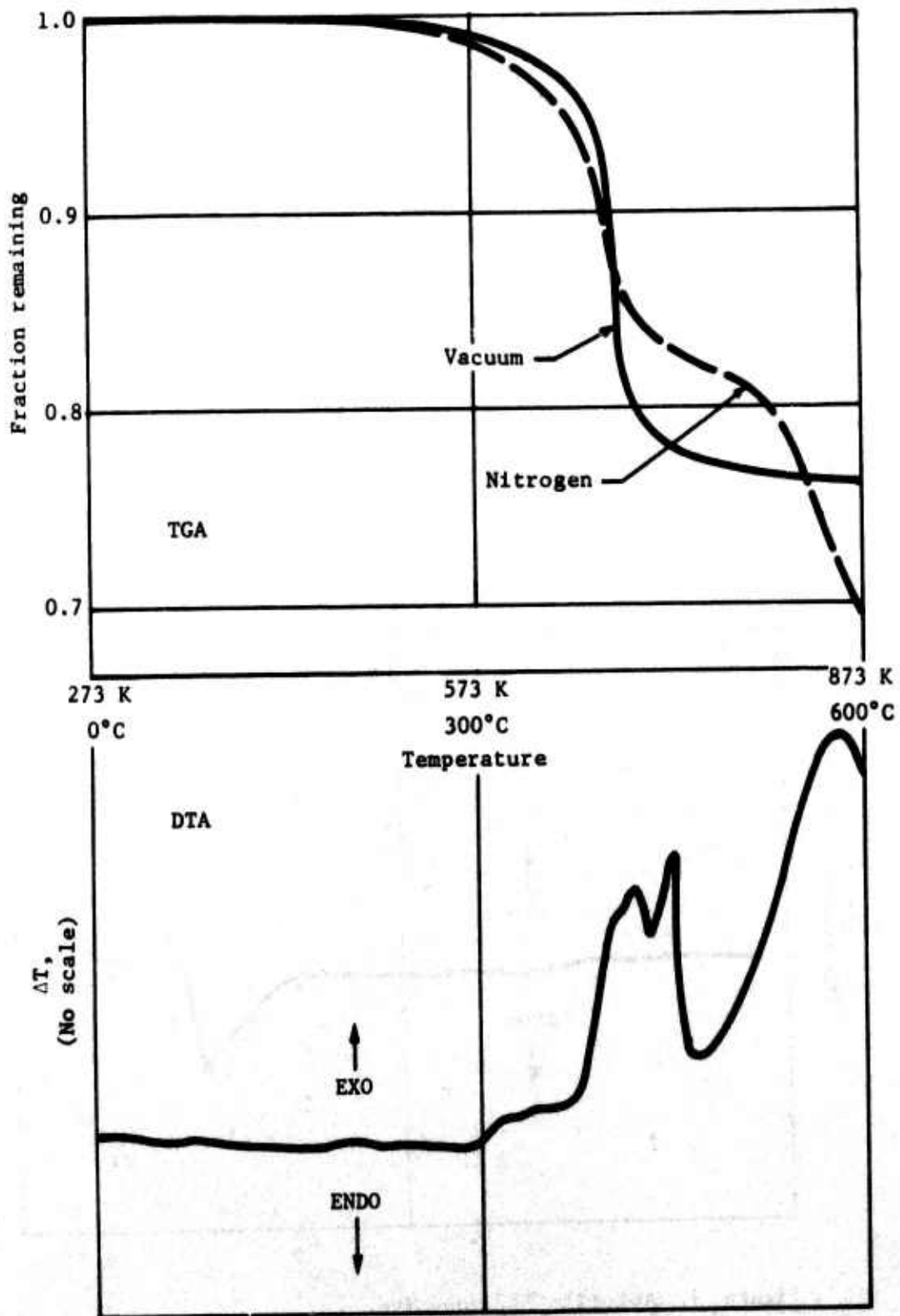

Figure 4. Epotek H-31 adhesive.

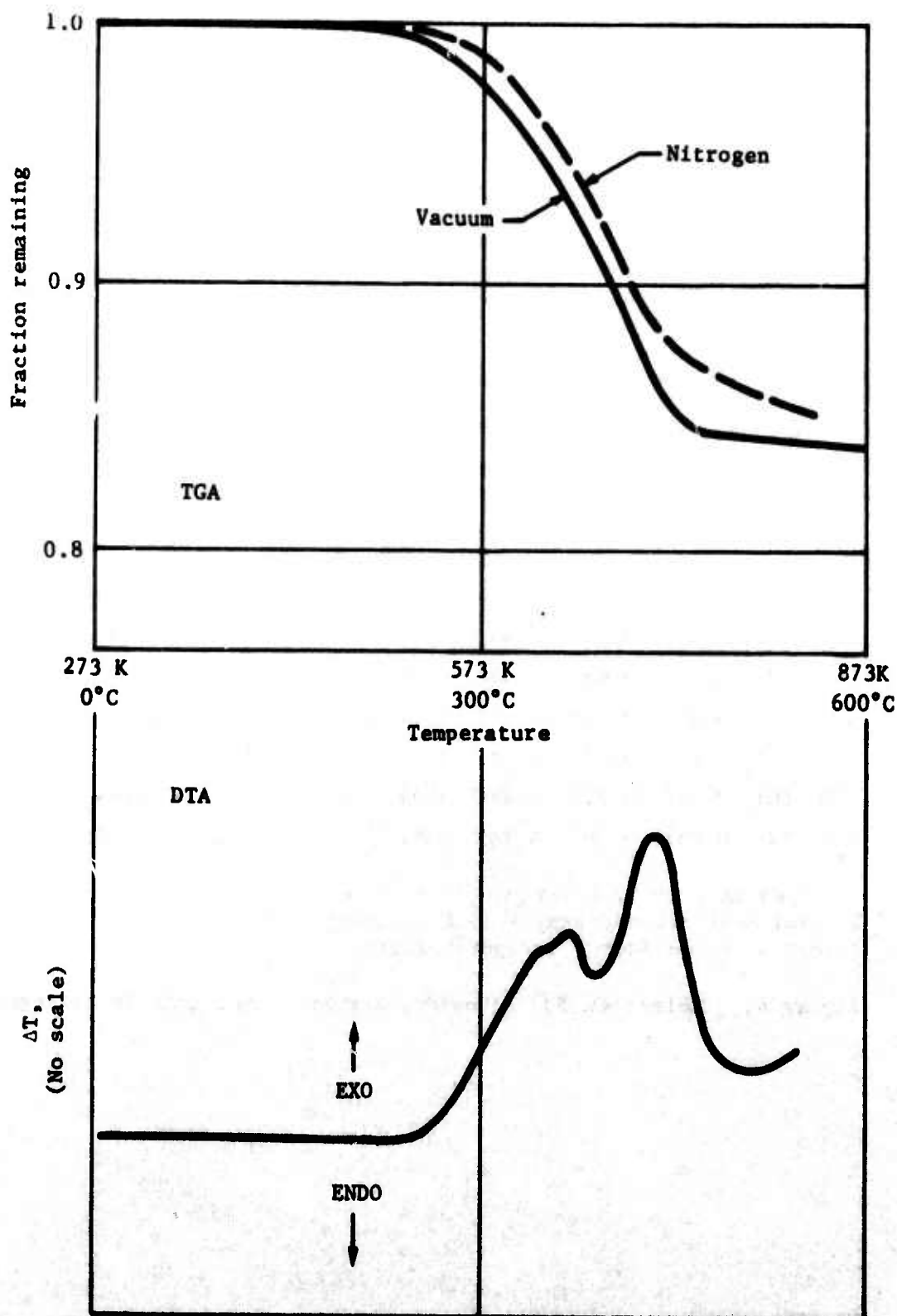

Figure 5. duPont 5504 adhesive.

The first order kinetic equation  $dx/dt = k(a-x)$  is used to describe the degradation, where

$a$  is the initial weight in mg.

$x$  is the weight loss in mg.

$k$  is the rate constant at the test temperature

$dx/dt$  is the rate of weight loss in mg./min.

The values of  $x$  and  $dx/dt$  were taken from a Mettler Thermoanalyzer I equipped with a TGA derivative output. Degradations complying with an Arrhenius rate model will plot linearly on scales of  $\log k$  and inverse  $1/T^\circ K$  with a slope proportional to the activation energy. The calculations of  $\log k$  and inverse absolute temperature are tabulated below and plotted in Figure 7. For the scales used in Figure 7, the activation energy in kilocal per mol is equal to  $-4.57$  times the slope.

T°C	T°K	dx/dt	x	a-x	k	log k	10 <sup>3</sup> /T°K
150	432	0.002	0.04	0.45	4.44 x 10 <sup>-3</sup>	-2.353	2.313
204	477	0.003	0.052	0.438	6.85 x 10 <sup>-3</sup>	-2.164	2.09
252	525	0.005	0.075	0.415	1.21 x 10 <sup>-2</sup>	-1.918	1.905
301	574	0.020	0.139	0.351	5.70 x 10 <sup>-2</sup>	-1.244	1.742
328	601	0.037	0.215	0.275	1.35 x 10 <sup>-1</sup>	-0.870	1.664
355	628	0.052	0.305	0.185	2.81 x 10 <sup>-1</sup>	-0.552	1.592

$a = 0.49$  mg., Slope  $b$  (Figure 7) =  $-4.16$   
 Initial Activation Energy = 19.0 Kcal/mol  
 (Slope  $a$  is considered insignificant)

Figure 6. Ablestick 535 Adhesive, Arrhenius Relation in Nitrogen

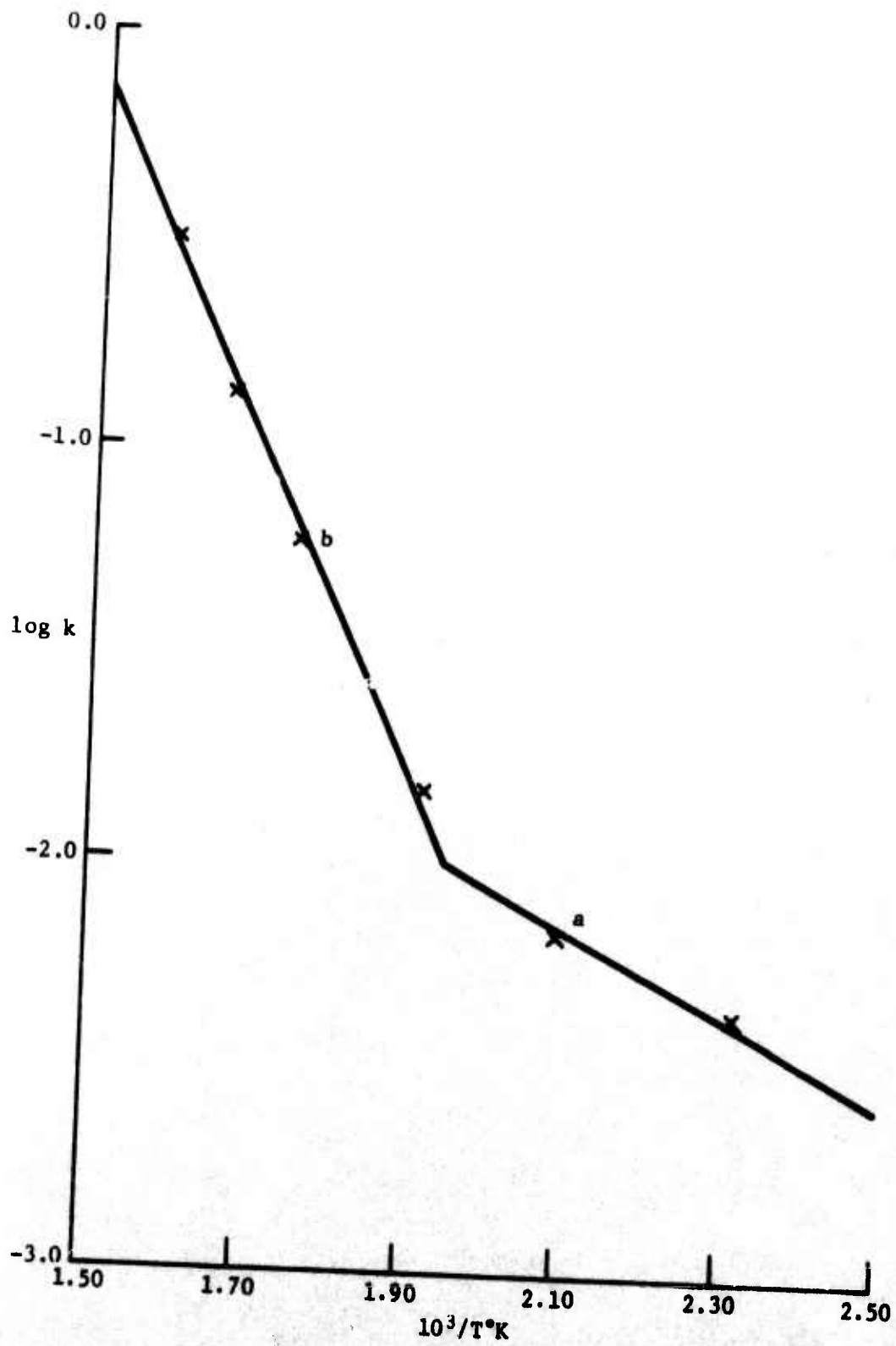

Figure 7. Arrhenius relation in nitrogen for Ablestick 535

	T°C	T°K	dx/dt	x	a-x	k	log k	10 <sup>3</sup> /T°K
a	210	483	0.002	0.004	3.956	5.06 x 10 <sup>-4</sup>	-3.296	2.070
	235	508	0.003	0.008	3.952	7.59 x 10 <sup>-4</sup>	-3.120	1.969
b	260	533	0.004	0.012	3.948	1.013 x 10 <sup>-3</sup>	-2.994	1.876
	285	558	0.005	0.016	3.944	1.268 x 10 <sup>-3</sup>	-2.897	1.792
b	312	585	0.006	0.024	3.936	1.524 x 10 <sup>-3</sup>	-2.817	1.709
	337	610	0.015	0.050	3.910	3.836 x 10 <sup>-3</sup>	-2.416	1.639
b	362	635	0.045	0.125	3.835	1.174 x 10 <sup>-2</sup>	-1.931	1.575
	386	659	0.145	0.380	3.580	4.05 x 10 <sup>-2</sup>	-1.393	1.517
b	410	683	0.385	1.100	2.860	1.346 x 10 <sup>-1</sup>	-0.871	1.464

a = 3.96 mg, Slope b (Figure 9) = -8.068

Initial Activation Energy = 36.872 Kcal/mol  
(Slope a is considered insignificant.)

Figure 8. Ablefilm 517 adhesive, Arrhenius relation in nitrogen.

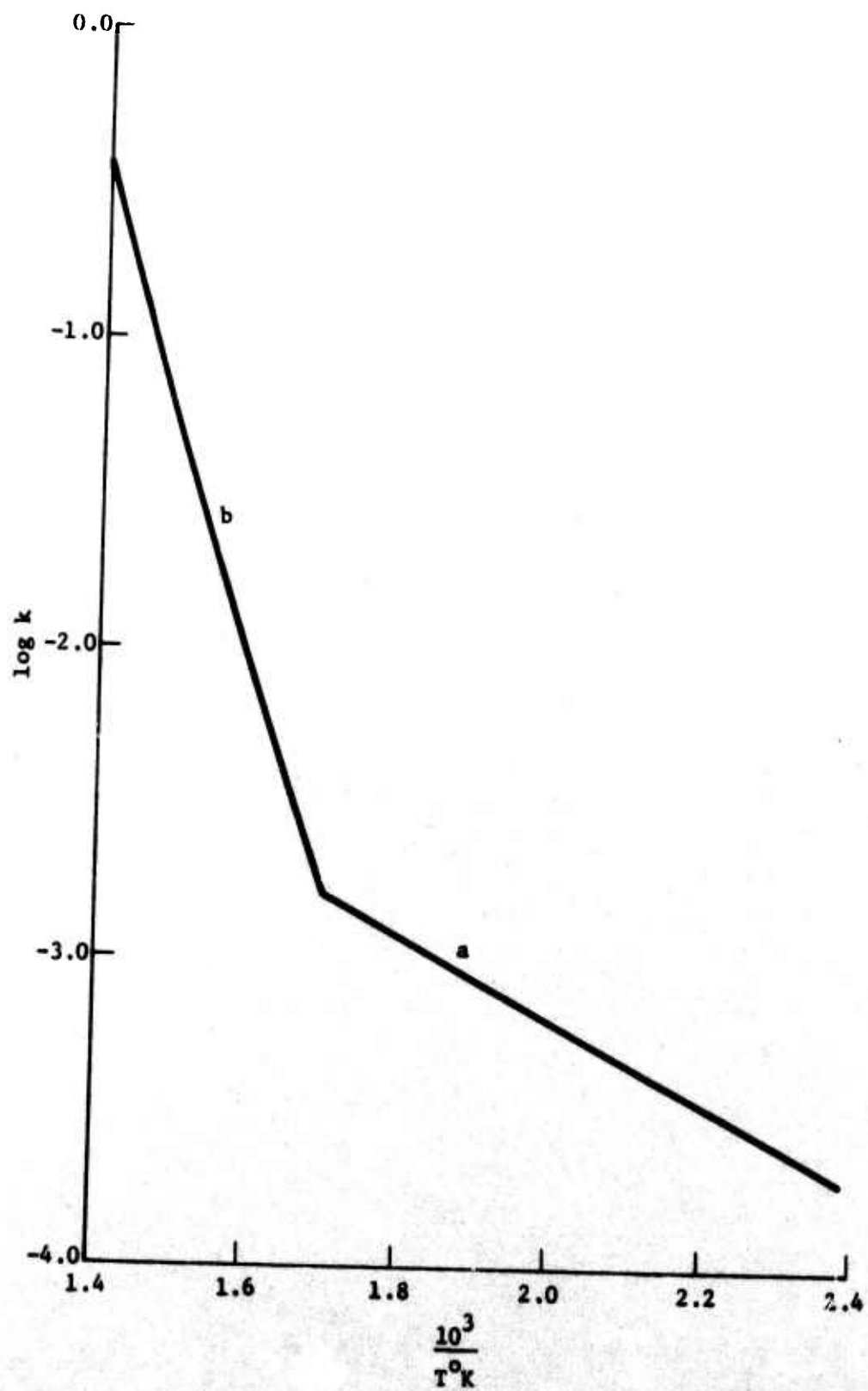

Figure 9. Arrhenius relation in nitrogen for Ablefilm 517.

T°C	T°K	dx/dt	x	a-x	k	log k	10 <sup>3</sup> /T°K
243	516	0.005	0.060	0.515	9.709 x 10 <sup>-7</sup>	-2.013	1.938
270	543	0.008	0.087	0.488	1.64 x 10 <sup>-6</sup>	-1.785	1.842
294	567	0.020	0.125	0.450	4.44 x 10 <sup>-6</sup>	-1.353	1.764
308	581	0.026	0.160	0.415	6.27 x 10 <sup>-6</sup>	-1.203	1.721
320	593	0.035	0.210	0.365	9.59 x 10 <sup>-6</sup>	-1.019	1.686
333	606	0.047	0.265	0.310	1.516 x 10 <sup>-5</sup>	-0.820	1.650
345	618	0.058	0.340	0.235	2.47 x 10 <sup>-5</sup>	-0.608	1.618

$x = 0.575$  mg., Slope (Figure 11) = -5.0

Initial Activation Energy = 22.85 Kcal/mol

Figure 10. Epotek H-31 adhesive, Arrhenius relation in nitrogen.



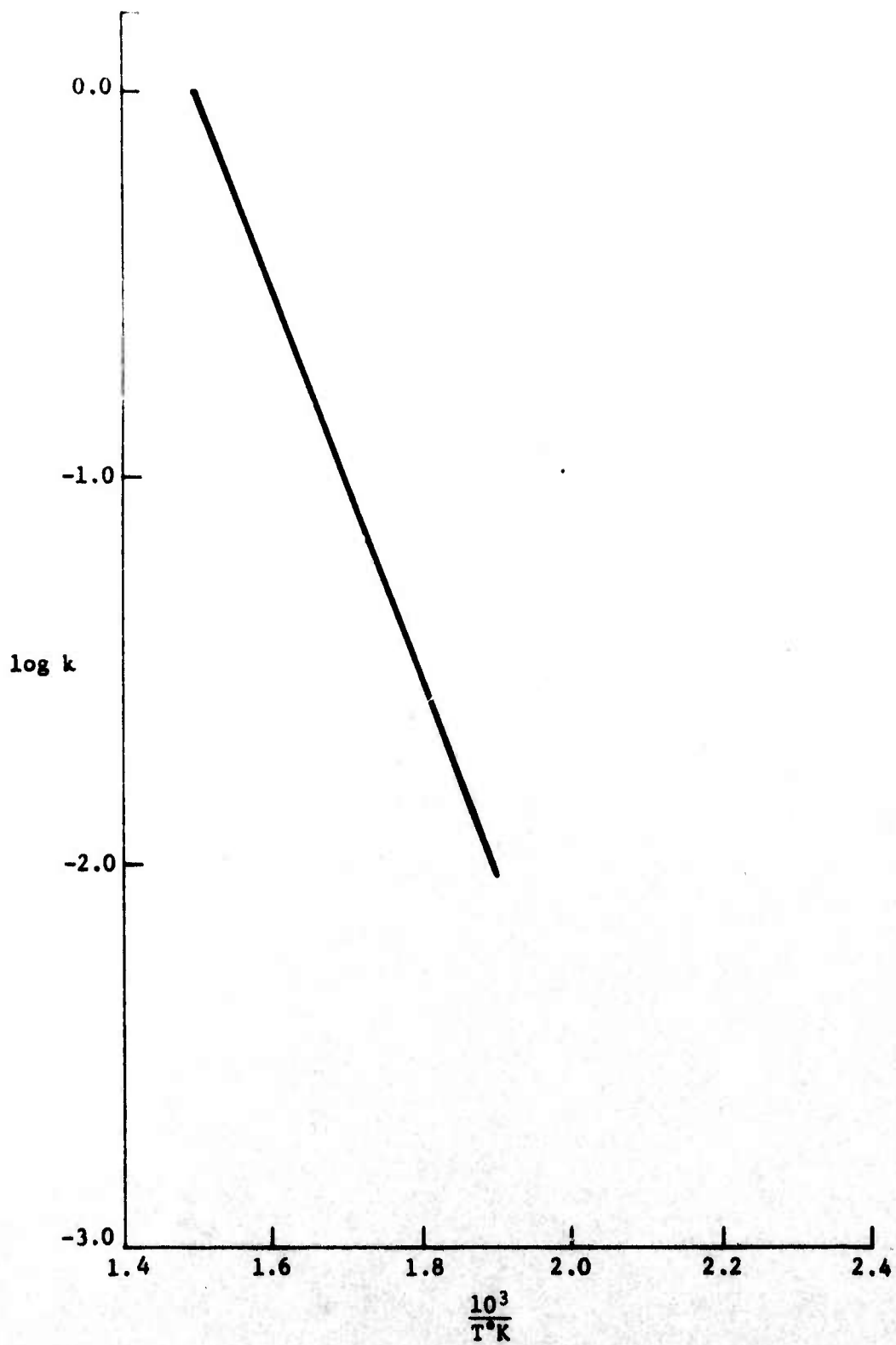

Figure 11. Arrhenius relations in nitrogen for Epotek H-31.

T°C	T°K	dx/dt	x	a-x	k	log k	10 <sup>3</sup> /T°K
240	513	0.002	0.005	1.455	1.37 x 10 <sup>-3</sup>	-2.813	1.949
265	538	0.008	0.021	1.439	5.56 x 10 <sup>-3</sup>	-2.255	1.859
290	563	0.025	0.068	1.392	1.79 x 10 <sup>-2</sup>	-1.747	1.776
303	576	0.038	0.118	1.342	2.83 x 10 <sup>-2</sup>	-1.548	1.736
315	588	0.052	0.178	1.282	4.06 x 10 <sup>-2</sup>	-1.392	1.701
328	601	0.067	0.244	1.216	5.51 x 10 <sup>-2</sup>	-1.259	1.664

a = 1.46 mg, Slope (Figure 13) = -5.88

Initial Activation Energy = 26.88 Kcal/mol

Figure 12. duPont 5504A adhesive, Arrhenius relation in nitrogen.

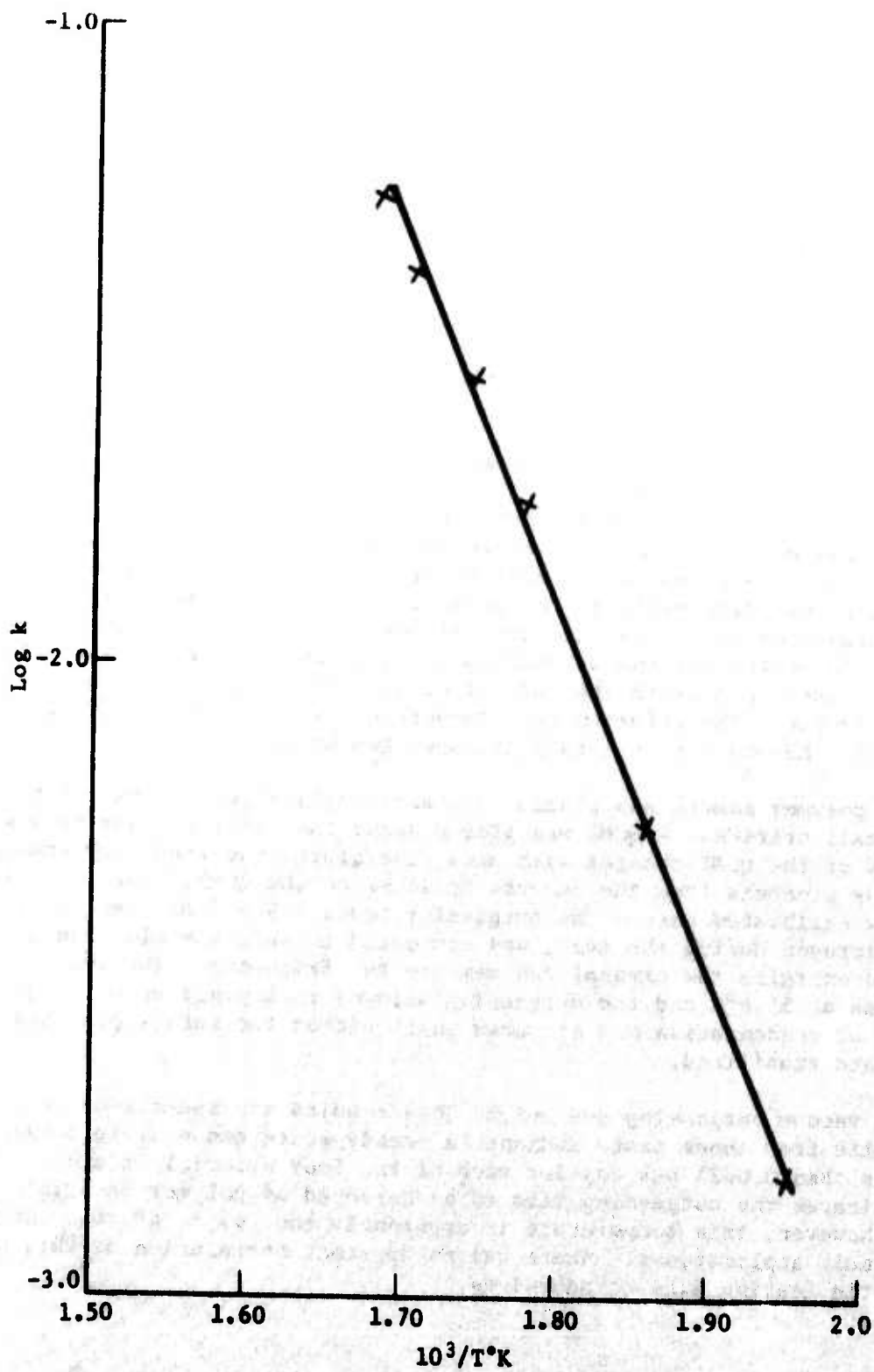

Figure 13. Arrhenius relation in nitrogen for duPont 5504A

The shape of the TGA curve depends primarily upon the kinetic parameters involved, namely, the reaction order, the frequency factor, and the activation energy. The values of these parameters can be of major importance in the elucidation of mechanisms involved in adhesive degradation and in the estimation of thermal stability.\*

Evaluation of the DTA and TGA data in conjunction with hybrid test data generated later, gives some insight into the relative value of tests. There does not appear to be any useful correlation between DTA data and performance of an adhesive in a hybrid. The TGA data correlate fairly well with the degree of contamination expected from an adhesive. The materials with the highest weight loss at 180°C have the lowest activation energies, and show the greatest tendency to cause surface leakage on devices.

#### Vacuum Outgassing and Weight Loss

Polymers used in hybrid microcircuits will outgas at operating temperatures. These products can contaminate the microcircuit or adjacent devices, degrading their performance. A maximum allowable outgassing rate should be established that will minimize the probability of device degradation. These vacuum outgassing tests measured the outgassing rate of the four test materials. In performing the outgassing test, a quartz crystal microbalance (QCMB) was used to measure the rate of condensible outgassing products issuing from the sample. The effusion cell temperature was set at 51.6°C (125°F) and the cooled QCMB was set at liquid nitrogen temperature.

The polymer sample was placed in a small cylindrical furnace fitted with a small orifice. A QCMB was placed above the orifice. The natural frequency of the QCMB changes with mass; therefore, the frequency changes as outgassing products from the furnace condense on the QCMB. The QCMB was mass-frequency calibrated before the outgassing tests. The QCMB, cooled with liquid nitrogen during the test, was connected to suitable electronic circuitry to energize the crystal and measure the frequency. The furnace was stabilized at 51.6°C and the outgassing allowed to impinge upon the QCMB. The rate of condensation was measured until either the rate approached zero or the rate stabilized.

The vacuum outgassing and weight loss results are summarized in Table 3. The results from these tests indicate a steady-state condensible outgassing rate less than 0.002% per day for each of the four materials tested. This test indicates the outgassing rate to be expected of polymer materials. At 51.6°C, however, this temperature is apparently too low to be relevant to microcircuit applications. There was no apparent correlation of this data with hybrid testing data on adhesives.

---

\*Norbert M. Bikales: "Characterization of Polymers." Interscience, N.Y. 1971

TABLE 3. VACUUM OUTGASSING AND WEIGHT LOSS

Material	Ablestick 535	Ablefilm 517	Epotek H-31	duPont 5504
Test temperature, (°F)	125	125	125	125
Monitor	QCMB	QCMB	QCMB	QCMB
Time in steady state test, (hr)	3	6	6	3
Condensable outgassing rate, (percent/day)	$3.97 \times 10^{-4}$	$1.50 \times 10^{-3}$	$1.84 \times 10^{-3}$	$1.94 \times 10^{-4}$
Weight loss, (percent)	0.21	0.46	0.37	0.053

#### Thermal Conductivity Tests

It is important that the polymer adhesive efficiently conducts the heat generated by the microcircuit to a heat sink so that allowable operating temperatures are not exceeded. These thermal conductivity tests are designed to allow evaluation of the conductivity of the four test polymers.

Thermal conductance and conductivity measurements were made using adhesive samples bonded between aluminum plates, the conductivity of the aluminum plates being a known value. The guarded hot plate technique, ASTM C-197, was used. Although the possibility of a temperature discontinuity at the aluminum-adhesive interface is acknowledged, the conductance and conductivity of the adhesive were calculated by assuming a linear temperature drop across the adhesive with no discontinuities at the interfaces. Multiple measurements of a variety of thicknesses of adhesive would have been required to evaluate the adhesive interface thermal resistance. (See Figure 14.)

The results of the thermal conductivity tests are presented in Table 4. The duPont 5504 had the highest conductance at 150°C while Ablestick 535 had the highest conductance at room temperature (25°C). Valid test data was obtained only with material thicknesses greater than the 1 to 5 mils usually employed in actual usage. It is concluded that the value of the thermal conductivity test in the evaluation of hybrid microcircuits adhesives is limited even though there was some degree of correlation with the thermal impedance determinations of the device.

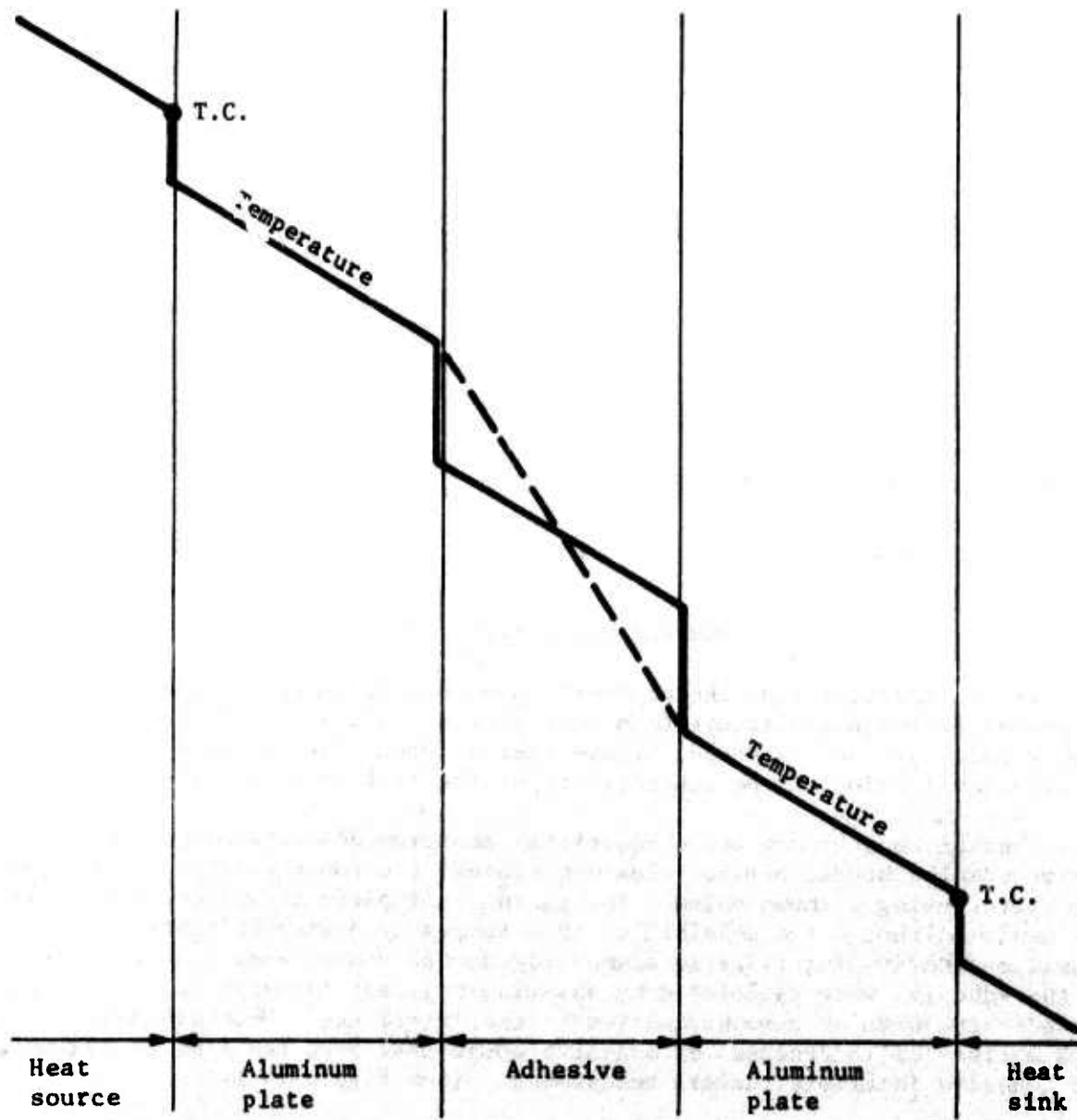

Figure 14. Temperature drop in thermal conductivity measurement.

TABLE 4. THERMAL CONDUCTIVITY

Material	Epotek H-31	duPont 5504	Ablestick 535	Ablefilm 517
Conductivity at RT W/cm°C	0.00068 ±0.00026	0.00094 ±0.00047	0.00384 ±0.00210	0.00136 ±0.00019
Conductivity at 150°C W/cm°C	0.00090 ±0.00042	0.00559 ±0.00480	0.00414 ±0.00235	0.00176 ±0.00049
Conductance at RT W/cm <sup>2</sup> °C	0.076 ±0.030	0.093 ±0.041	0.130 ±0.071	0.039 ±0.006
Conductance at 150°C W/cm <sup>2</sup> °C	0.101 ±0.048	0.550 ±0.472	0.141 ±0.080	0.051 ±0.014

#### Ion and Conductance Tests

The presence of certain metallic elements, such as sodium, potassium, copper, boron, phosphorus and chlorine, in hybrid microcircuits can be detrimental to performance. Tests were conducted to determine the presence of specific ions in the four test polymers. The percentages by weight of the elements Na, Ca, Si, Cu, B, Ag, and Al were determined using the microgram film spectrometer. Qualitative tests for chlorine were made using the same technique. To supplement this test, samples of each adhesive were placed in water and the specific conductance of the water measured at 0, 24 and 40 hours after immersion.

Table 5 presents the specific ion and ion conductance test summary. The ion test may be used to determine traces of elements potentially poisonous and detrimental to hybrid microcircuits. The test gives no evidence of ion availability. Only the Epotek H-31 adhesive had traces of chlorine. Ablestick 535 had the least conductivity after 24 and 48 hours for the materials tested. This test is useful because materials can be analyzed for elements that are potentially detrimental to circuitry whether or not ion availability can be determined.

#### Dimensional Stability

Maximum dimensional stability of the polymer during curing and aging is desirable to help ensure integrity of the bond. The amount of shrinkage is indicative of dimensional stability. For determination of shrinkage during cure, specimens of each polymer were prepared into 0.500 x 7.000-inch thin film strips on a frosted glass surface. The specimens were then cured in accordance with the manufacturer's recommendations. Changes in width and length were accurately determined to calculate shrinkage.

To determine shrinkage during life, specimens were placed in a ventilated oven with controlled humidity. Measurements were made after each of these conditions: room temperature (RT) without relative humidity (RH) control, 7 days at 23 ±2°C and 45 ±5% RH, 7 days at 50 ±2°C and 20 ±5% RH, and 7 days at 23 ±2°C and 45 ±5% RH.

TABLE 5. SPECIFIC IONS AND ION CONDUCTANCE

Materials		Epotek H-31	duPont 5504	Ablestick 535	Ablefilm 517
Specifications, percent by weight through film spectrometer	Na	0.001	0.001	0.001	0.001
	Ca	0.001	0.001	0.100	0.001
	Si	0.001	0.001	0.200	0.200
	Cu	0.001	0.050	0.005	0.001
	B	0.100	0.001	0.100	0.100
	Ag	1.000	1.000	1.000	0.001
	Al	0.005	0.001	0.100	0.005
Conductance, mhos/cm	Controls				
	0 hr at 0.4	0.0	0.0	0.0	0.0
	24 hr at 4.6	0.4	0.4	0.1	0.7
	48 hr at 9.0	1.1	1.0	0.0	1.5

Shrinkage of the adhesive materials varied between zero and 0.15% during curing; shrinkage during aging varied between zero and 0.09 percent. Ablestick 517 expanded 0.14% during RT aging. Because of the small amount of shrinkage, setting maximum allowable shrinkage limits for an adhesive for microcircuits would not necessarily help in determination of an acceptable adhesive material. (See Table 6 for test results.)

TABLE 6. CURE AND AGING SHRINKAGE

Material	Epotek H-31	duPont 5504	Ablefilm 517	Ablestick 535
Cure temperature, °C	150	160	150	150
Cure time, (hr)	1/2	16	1	1/2
Shrinkage on cure, (percent)	-0.15	-0.03	0.0	0.0
	-0.12	-0.04	0.0	0.0
Room temperature, (percent), for 30 days W/O controlled RH	+0.16	+0.04	+0.14	-0.07
	+0.24	+0.05	+0.04	-0.02
7 days at 23 ± 2°C and 45 ± 5% RH, (percent)	-0.02	-0.03	-0.09	0.0
	-0.02	-0.03	-0.09	0.0
7 days at 50 ± 2°C and 20 ± 5% RH, (percent)	0.0	-0.03	-0.02	0.0
	0.0	-0.03	-0.03	0.0
7 days at 23 ± 2°C and 45 ± 5% RH, (percent)	-0.02	-0.03	-0.09	0.0
	-0.02	-0.03	-0.09	0.0
NOTE: "+" represents the expansion "-" represents the shrinkage				

## SECTION IV

### PHASE 3, PROCESSING EVALUATION

To evaluate the utility of a polymer adhesive for hybrid microcircuits, processing characteristics must be considered in addition to the basic material properties evaluated in the previous section. Lap shear strength after temperature storage or thermal cycle, the effect of bond thickness on electrical conductivity, the effect of six-month shelf life on lap shear strength, repairability and handling properties of adhesives, and the effects of adhesives on wire bonding and hermetic sealing were evaluated during Phase 3.

In general, an ideal test specimen is one that closely matches in form and function the material or device to be evaluated. It would appear that the best way to evaluate chip adhesives is to bond chips to a typical substrate and then test and bond in some manner. Unfortunately, the process is difficult to control with sufficient precision to allow differences to be sufficiently amplified for comparison. For example, it is difficult to precisely vary adhesive thickness, and it is very difficult to get a reproducible mechanical test on a chip because of its physical size.

Because of these difficulties, a special lap shear test specimen was used. The basic specimen was two pieces of gold-plated Kovar shim stock with an adhesive bond lap joint of 0.1-inch square. The specimens were assembled and cured in a Teflon fixture that accurately controls bond area and adhesive thickness. Such a specimen is easily evaluated for mechanical strength by a lap shear test. It may also be checked for electrical conductivity by use of a bridge.

#### Lap Shear Strength

Lap shear specimens were prepared for each adhesive/cure combination. There were two cures used for each adhesive except duPont 5504. This material has an alternative cure of 260°C for one hour, but the temperature was judged to be too high for hybrid usage. The specimens were divided into four groups. The control specimens were pull tested with no exposure to special environment. The other three groups were each subjected to a different environment: (1) 200 hours at 125°C, or (2) 100 hours at -100°C, or (3) 100 cycles from -75°C to 150°C. Average pull test data are shown in Table 7. No general conclusions can be reached that would apply to all materials. The fact that lap shear strength is subject to a great deal of scatter and that the minimum strength needed in most hybrids is relatively small, makes the usefulness of such a test as routine evaluation questionable.

#### Electrical Conductivity

Past experience with conductive epoxies has shown that with improper mixing or with inferior materials, the electrical resistance of a chip bond will be unacceptably high. This can also be caused by using a bond thickness that is great enough to allow particle settling before cure. An attempt was

TABLE 7. PROCESS EVALUATION LAP SHEAR DATA

Material Manufacturer	Cure Time	H-31 Epotek	5504 duPont	ECF 535 Ablestick	517 Ablefilm
Lap shear Psi fresh epoxy	Control	120°C 150°C 1 hr 1/2 hr	160°C 16 hr	125°C 175°C 2 hr 1/2 hr	75°C 150°C 3 hr 1/2 hr
	200 hr at 125°C	1640 1510	1950	2960 3530	2300 3310
	100 hr at -100°C	2060 1876	1710	3160 3130	2910 2800
	100 cycles at -75°C +150°C	1370 2170	2230	3250 3500	1710 3110
Repair	1710 2010	2410	3010 3380	3960 3110	
Lap shear Psi 6-month shelf life	Control	2060 1810	1180	2450 1350	1300 1760
	200 hr at 125°C	550 1400	760	1616 2250	1450 1250
	100 hr at -100°C	1010 950	1150	916 1250	550 1133
	100 cycles at -75°C +150°C	760 883	650	1400 1550	513 1933
		975 866	616	1216 1966	650 633

made to check this phenomenon by making samples of each material with bond thickness ranging from 0.001 to 0.005 inches. The first attempt to measure conductivity showed that the probe contact resistance was so much greater than all bond resistances that they could not be measured. A Kelvin technique was tried, but it showed all epoxies to be too low in resistance to be measured reliably. We conclude that there was no measurable effect of thickness on conductivity for the material evaluated.

#### Shelf Life

The effect of six months' storage of the four adhesives on lap shear strength was measured. All materials were stored according to manufacturer's recommendations. After storage, lap shear specimens were made and pull tested. The results in Table 7 show very significant reduction in strength after a six-month shelf life. This would indicate that effective shelf life control on adhesives should be exercised.

#### Repairability-Handling

Repairability was evaluated by making lap shear specimens of each adhesive/cure combination. The bonds were broken in the pull test machine; the bonds were remade, and pull tested again. The lap shear strength of these repaired specimens is given in Table 7. Here again, there is no general trend. All materials were acceptably strong after repair.

Handling characteristics are highly subjective and dependent on personal preference. The only way to evaluate these properties was to ask the people who prepared the samples.

Opinions of the engineers and technicians conducting the test are tabulated:

Material	Comment
duPont 5504A	This adhesive is fairly hard to handspread. It develops a skim over the top before the chips can be placed down. It does not flow easily. It is more difficult to cut and chip away than the other epoxies. Each chip broke when removal was attempted.
Epotek H-31	This adhesive is easy to spread by hand. It flows easily. After being cured, there is no evidence of excess flowing of resin. The chips were easy to remove and all five chips came off in one piece.
Ablestick ECF535	After cutting preforms from the sheet, the ECF535 is very easy to handle. No excess flow was noted. Two of the chips broke into pieces when being removed.
Ablefilm 517	After cutting preforms from the sheet, the 517 film was easy to handle and use in making epoxy substrates into packages.

Although indicative of handling characteristics, this qualitative analysis cannot be conveniently incorporated into specifications in a quantitative statement. A qualitative analysis by the engineers and technicians provided the following conclusions:

1) Handling Characteristics:

Best H-31 - Epotek  
517 - Ablefilm  
ECF535 - Ablestick

Worst 5504 - duPont

2) The 16-hour cure time required for the duPont epoxy is not convenient.

The ideal adhesive material should spread a limited amount to show adequate wetting properties, but should not spread excessively (creep). This evaluation of wetting properties and creep onto chips was qualitative, using chips on thin and thick film substrates. The handling characteristics tests indicated Epotek H-31 had the best handling characteristics, while duPont 5504 had the worst. Hence, the "best and worst" were chosen for evaluation of wetting properties. The selected adhesives were applied to the pads and allowed to stand for varying lengths of time before attachment of the chips. Longer periods of time before attaching the chip will increase the spreading tendency, amplifying this characteristic.

The wettability and creep of the materials investigated showed that each had capability of wetting the pads to result in good adhesive strength. None showed a tendency toward excessive creep that could cause problems in wire bonding.

#### Effect of Adhesives on Wire Bonding and Hermetic Sealing

The use of epoxies in hybrids may cause invisible films to form on surfaces. This can create problems with certain processes. Using hybrid test vehicles, it was found that there was no effect on sealing yield. There was slight difficulty in making ultrasonic wire bonds. The difficulty was overcome by increasing the power and time parameters on the wire bonder. The change in power setting is not in itself harmful, except that it could cause a greater tendency for wire bond heel cracking.

Ultrasonic wire bonds are accomplished by means of the scrubbing action of the ultrasonic energy used. Theoretically, any contamination of the mating surfaces to be bonded (wire and substrate metalization) is scrubbed away allowing an intimate contact of the pure metal(s) thereby causing them to fuse. One can see why more difficulty in bonding is incurred when more than an ordinary amount of contamination exists on surfaces to be wire-bonded. In the case mentioned, more time and power were necessary to break through the epoxy contamination.

## SECTION V

### PHASE 4, HYBRID TESTING

Hybrid testing determined the effects of aging and high stress environments upon hybrid microcircuits using the four selected adhesives for bonding. Test specimens employing eutectic chip bonding were also included for comparison purposes. A secondary objective was to determine the adequacy of the tests to evaluate hybrid microcircuits employing adhesive bondings. A MOSFET device and a power transistor were chosen as the test chips. There were two package types: weld sealed and solder sealed. Hence there were ten (10) test groups, five of each package type. Of these five groups, three utilized eutectic substrate bonds and epoxy chip bonds with Epotek H 31, duPont 5504A, and Ablestick 535 material respectively, one utilized eutectic chip bonds and substrates bonded with Ablefilm 517, and one group utilized both chip and substrate eutectic bonds. A minimum of ten packages of each type were fabricated by MMC in order to obtain a minimum of eight packages in each group for evaluation testing. The eight best test packages of each type were selected for testing after hermeticity, X-ray, and electrical screening.

As a major uncertainty associated with the use of adhesives is the effect of long-term aging, half of the test samples were subjected to an accelerated-temperature aging stress at  $180^{\circ}\text{C}$  for 132 hours. The equivalent hours of life for each material at  $125^{\circ}\text{C}$ , in accordance with Arrhenius analysis of polymer degradation kinetics, is shown in Table 2.

Figure 15 presents the test flow diagram; the numbers in the upper right-hand corners indicate the quantity of test specimens. With about half of the test items subjected to the accelerated aging test, the effect of polymer breakdown or capability to meet minimum requirements can be assessed. As shown in Figure 15, samples of aged and unaged parts were subjected to step stress power cycling and thermal shock. The thermal shock limits were increased to  $-200$  to  $+300^{\circ}\text{C}$  in  $25^{\circ}\text{C}$  increments. The power cycling was performed in 5,000-cycle (83 hr) increments until 50,000 (830 hr) cycles accrued. The tests to high levels provide information on the capability, safety factor, and margin of the aged and unaged adhesively bonded devices to meet these environments, and to indicate test levels or limitations that may be required for such devices.

Detailed step-by-step descriptions of the testing performed and the results are given in the following subsections after a description of the test specimens.

#### Test Specimens Description

The hybrid test vehicles used a metal oxide semiconductor silicon field-effect transistor (MOSFET) device (Fig. 16) as a surface contamination indicator, and a power transistor to test the thermal/electrical

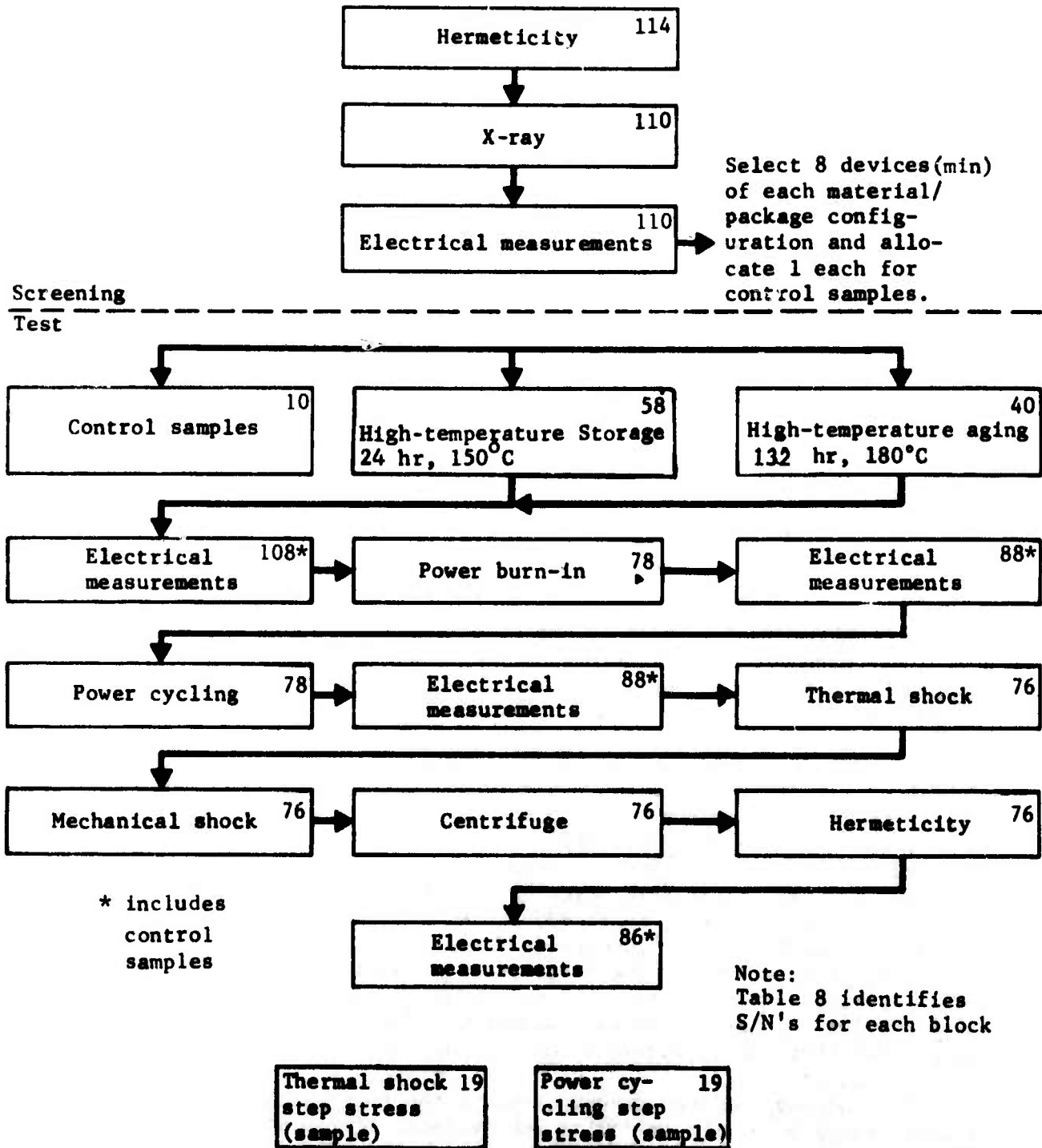

Figure 15. Test flow diagram.

characteristics of the polymer adhesives under extreme conditions. These devices were chosen rather than complex ICs for ease of analysis. Both a solder seal package and a weld seal package were used. A Siliconix CPMIOI (3N167) MOSFET chip was chosen to detect changes in leakage current. The geometry of its aluminum metallization lends itself to detecting surface leakages because of its very fine interdigitated structure and because its surface is totally unprotected. The device's own gate leakage ( $I_{GSS}$ ) is less than  $-0.1$  nA at  $V_{GS} = -20$  V. The length of the gate metallization is  $330 \times 10^{-3}$  inches, while the distance between the gate metallization and the source and drain metallizations is  $0.25 \times 10^{-3}$  inches. Therefore, a contaminant sheet resistivity of  $5 \times 10^8$  megohms per square can be detected by no less than a 100% increase in gate leakage current.

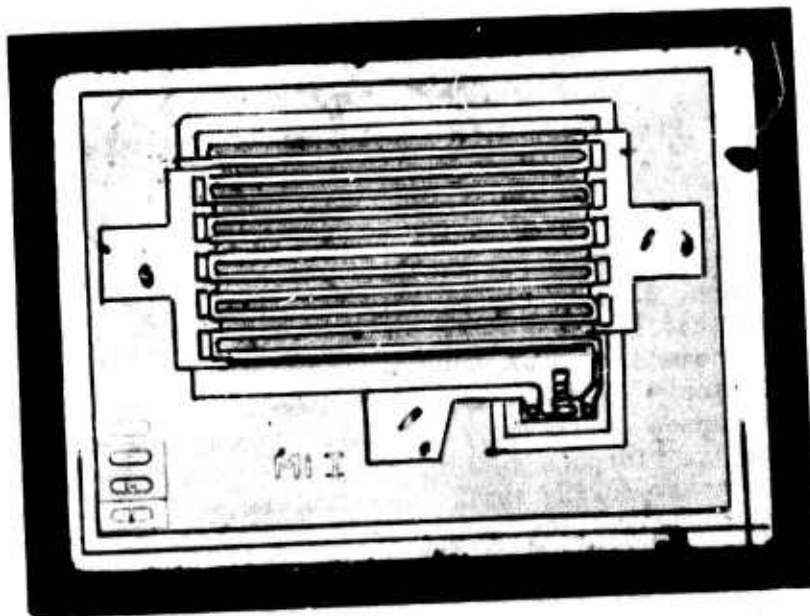

Figure 16. MOSFET 3N167.

A TI 2N2987 chip (Fig. 17) was chosen to evaluate the thermal and electrical resistances incurred in a polymer chip bond. The 2N2987 is a 15 watt high-frequency power transistor with a 1-ampere collector rating. The chip dimensions measure  $0.045 \times 0.080$  inches, yielding a die bond area of  $0.0036$  in.<sup>2</sup>. This chip was chosen because of its typical size and geometry, and relatively low and repeatable collector to emitter saturation voltage (typically  $0.2$  V at  $I_c = 200$  mA and  $I_B = 20$  mA). Since the collector current passes through the die bond, a measurement of the collector to emitter saturation voltage,  $V_{CE(SAT)}$ , evaluates the electrical quality of the bond.

Four (4) MOSFET chips and four (4) power transistors were mounted in each hybrid package (Fig. 18).

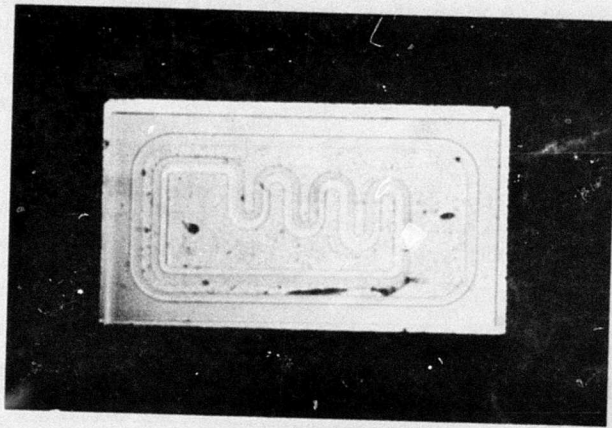

Figure 17 Power Transistor TI 2N2987

The hybrid packages (Fig. 18) used for the test vehicles are the Bendix 5/8 x 5/8-inch, 22-lead flatpack (P/N 10-299122-1) and the Tekform 5/8 x 5/8-inch, 22-lead flatpack (P/N 50181). The size and pin count were selected to accommodate four MOSFETs (3 pins each device, plus common-body connection = 13 pins) and four power transistors (2 pins each device, plus common collector = 9 pins). The Bendix package was solder-sealed in a Dix flatpack sealer, thus subjecting the polymer adhesive to thermal stress during seal. The Tekform package was weld-sealed using a special weldable lid purchased for this package from Solid State Equipment Corporation. The Tekform package was sealed on a Solid State Equipment Corporation weld sealer. The weld heat is localized and no thermal stress was imposed on the polymer during sealing.

The substrates used were 0.025-inch thick 96% alumina material with standard finish for thick-film printing. Bonding pads and conductors were Plessey C7005 gold-palladium that proved to be most compatible with ultrasonic aluminum bonds after extended high temperature exposure.

Extensive tests conducted before Viking Hybrid build showed pure gold and platinum-gold promote bond degradation at the aluminum/gold interface because of unequal diffusion rates of gold to aluminum versus aluminum to gold.

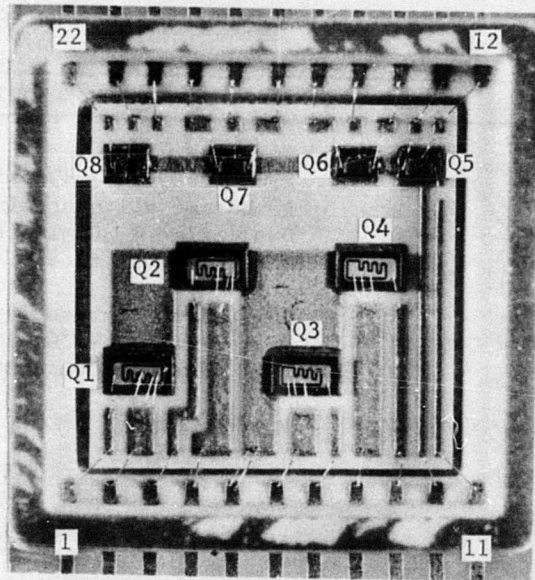

Figure 18. Hybrid package used in testing.

The reverse side of the substrate was printed with MMC's standard checkerboard pattern for eutectic bonding to the package. The substrate was bonded into the package before polymer adhesive die bonding using a eutectic preform. Eutectic bonding of the substrate was chosen so that the only polymer adhesive in the package would be the chip-to-substrate adhesive. If a substrate-to-package adhesive were used in the same package with a chip adhesive, it would be impossible to distinguish which polymer was affecting device properties. Two of the ten test groups utilized adhesively bonded substrates and eutectically bonded die. Also, two groups of test packages having eutectic substrate and eutectic chip bonds were fabricated and included in the test matrix to establish a baseline of performance for the test vehicle.

Both ultrasonic (aluminum wire) and thermocompression (gold wire) bonds were used in the test package. This introduced gold/aluminum couples that would be quite sensitive to possible corrosive effects of polymer outgassing or decomposition products. The aluminum wire was used in the MOSFET pad-to-thick-film substrate and in the power transistor-to-substrate bonds. The gold was used in the substrate-to-package bonds. The size and number of bond wires to the power transistor provide adequate margin to ensure that wire sag or melt will not occur. All hybrid test packages were fabricated to the general requirements of MIL STD-883, Level B, or to the requirements of the Martin Marietta processes in the case of adhesive bond visual criteria. Pre-cap visual and electrical tests ensured the proper performance of each device.

The detailed requirements for the tests that were performed are tabulated.

TEST	CONDITION	DETAILED REQUIREMENTS
Hermeticity		
	Fine leak	A Bomb pressure = 30 psig -0, +10% B Bomb time = 1 hour minimum C Dwell time = 30 minutes maximum D Measured leak rate $5 \times 10^{-7}$ atm/cc/sec
Gross leak	A	Perform full gross leak test
	B	Bomb pressure = 30 psig -0, +10%
	C	Bomb time = 5 hours minimum
X-ray	A	Radiographic film at two densities
	B	Y axis only
Electrical measurements	A	See Page 44
	B	Perform at $25 \pm 5^{\circ}\text{C}$ ambient
High temperature storage I	A	Storage temperature = $150^{\circ}\text{C}$
	B	Test duration = 24 hours
High temperature aging II	A	Storage temperature $180^{\circ}\text{C}$
	B	Test duration = 132 hours
Power burn in	A	Test temperature = $125 \pm 5^{\circ}\text{C}$ ambient ( $25 \pm 5^{\circ}\text{C}$ )
	B	Test duration = 240, -0, +24 hours
	C	Test circuit (See Fig. 1.)
Power cycling	A	Power levels = sufficient to raise junction temperature to $100^{\circ}\text{C}$
	B	Test duration = 5000 cycles (~83 hours)
	C	Test circuit (See Page 44)
Thermal shock	A	Fifteen cycles, +100, -0 + $5^{\circ}\text{C}$ and -0, -5 + $0^{\circ}\text{C}$
Mechanical shock	A	5 blows in $X_1$ , $Y_1$ and $Z_1$ axes, 1500 G
Centrifuge	A	Accelerator = 15 kg
	B	Test time = 1 minute minimum
	C	Axis = $Y_1$ only
	D	Fixture in Rigidex potting compound on flat aluminum plates.

Thermal shock (step stress) A

Perform 15 cycles of thermal shock using each of the following temperature extremes:

Step 1 +125 -0, +5°C and -25 +0, -5°C (liquid - liquid)

Step 2 +150 -0, +5°C and -50 +0, -5°C (liquid - liquid)

Step 3 +175 -0, +5°C and -75 +0, -5°C (air - air)

Step 4 +200 -0, +5°C and -100 +0, -5°C (air - air)

Step 5 +225 -0, +5°C and -125 +0, -5°C (air - air)

Step 6 +250 -0, +5°C and -150 +0, -5°C (air - air)

Step 7 +275 -0, +5°C and -175 +0, -5°C (air - air)

Step 8 +300 -0, +5°C and -200 +0, -5°C (air - air)

B Perform continuity test after each step as a check for failures

C Perform steps 1 through 8 or until 50% of the test devices have failed

Power cycling

A Perform 5000 cycles as previously specified

B Perform continuity test as a check for failures

C Repeat A and B until 50% of the test devices have failed or until 50,000 cycles (830 hr) have been run

Phase 4 began July 25, 1973 and ended December 17, 1973. Out of 114 test specimens, the best 108 were chosen for further evaluation. Table 8 identifies the test groups, the serial numbers within each group, and the tests performed on each serial number. The test samples were categorized in the following ten groups:

1A	Epotek H-31	Braze	(Chip Adhesive)
2A	Epotek H-31	Weld	(Chip Adhesive)
1B	duPont 5504A	Braze	(Chip Adhesive)
2B	duPont 5504A	Weld	(Chip Adhesive)
1C	Ablestick 535	Braze	(Chip Adhesive)
2C	Ablestick 535	Weld	(Chip Adhesive)
3	Eutectic	Braze	( No Adhesive)
4	Eutectic	Weld	( No Adhesive)
5	Ablefilm 517	Braze	(Substrate Adhesive)
6	Ablefilm 517	Weld	(Substrate Adhesive)

*Fine and gross leak tests* were performed in accordance with MIL-STD-883, Method 1014, Conditions A and C. The purpose of the initial tests is to eliminate nonhermetic packages for the test sequence. One hundred fourteen test specimens were subjected to the fine leak test on July 25, 1973. Three test specimens failed, leaking in excess of  $5 \times 10^{-7}$  atm/cc/sec. The serial numbers (SNs) were 061, 078, and 132. SNs 061, 078, and 132 also failed the Step 1 gross leak test conducted on July 26, 1973. These three test specimens were removed from further testing. The remaining test specimens passed the Step 2 Gross Leak test, also conducted on July 26, 1973.

*Radiographic film techniques* as specified in MIL-STD-883, Method 2012, were employed in this inspection. Film was shot at two different densities to ensure accurate interpretation of the radiographs. This test provided chip-to-substrate bond and other internal package data used in the selection phase test of the test sequence.

Radiographic screening was conducted on August 6, 1973. Anomalies were revealed in 18 test specimens. The principal discrepancy was that the lids were very much off center. These rejects are not significant as to the adhesive evaluation.

*Power transistor and FET parametric measurements* were performed at room ambient temperature. The power transistor  $V_{CE(SAT)}$  and the MOSFET ( $I_{GSS}$ ) were measured. The averaged results for the four devices in each control sample are presented below:

Group	$V_{CE}$ , Volts	$I_{GSS}$ , $10^{-9}$ Amperes
1A	0.166	0.013
1B	0.153	0.011
1C	1.200	0.015
2A	1.960	0.010
2B	0.145	0.014
2C	2.300	0.016
3	0.105	0.011
4	0.113	0.010
5	0.168	0.009
6	0.122	0.015



Run No.	Start	End	Temp	Pressure	Flow	Analysis	Notes
001	000	001	100	100	100	100	
002	001	002	100	100	100	100	
003	002	003	100	100	100	100	
004	003	004	100	100	100	100	
005	004	005	100	100	100	100	
006	005	006	100	100	100	100	
007	006	007	100	100	100	100	
008	007	008	100	100	100	100	
009	008	009	100	100	100	100	
010	009	010	100	100	100	100	
011	010	011	100	100	100	100	
012	011	012	100	100	100	100	
013	012	013	100	100	100	100	
014	013	014	100	100	100	100	
015	014	015	100	100	100	100	
016	015	016	100	100	100	100	
017	016	017	100	100	100	100	
018	017	018	100	100	100	100	
019	018	019	100	100	100	100	
020	019	020	100	100	100	100	
021	020	021	100	100	100	100	
022	021	022	100	100	100	100	
023	022	023	100	100	100	100	
024	023	024	100	100	100	100	
025	024	025	100	100	100	100	
026	025	026	100	100	100	100	
027	026	027	100	100	100	100	
028	027	028	100	100	100	100	
029	028	029	100	100	100	100	
030	029	030	100	100	100	100	
031	030	031	100	100	100	100	
032	031	032	100	100	100	100	
033	032	033	100	100	100	100	
034	033	034	100	100	100	100	
035	034	035	100	100	100	100	
036	035	036	100	100	100	100	
037	036	037	100	100	100	100	
038	037	038	100	100	100	100	
039	038	039	100	100	100	100	
040	039	040	100	100	100	100	
041	040	041	100	100	100	100	
042	041	042	100	100	100	100	
043	042	043	100	100	100	100	
044	043	044	100	100	100	100	
045	044	045	100	100	100	100	
046	045	046	100	100	100	100	
047	046	047	100	100	100	100	
048	047	048	100	100	100	100	
049	048	049	100	100	100	100	
050	049	050	100	100	100	100	
051	050	051	100	100	100	100	
052	051	052	100	100	100	100	
053	052	053	100	100	100	100	
054	053	054	100	100	100	100	
055	054	055	100	100	100	100	
056	055	056	100	100	100	100	
057	056	057	100	100	100	100	
058	057	058	100	100	100	100	
059	058	059	100	100	100	100	
060	059	060	100	100	100	100	
061	060	061	100	100	100	100	
062	061	062	100	100	100	100	
063	062	063	100	100	100	100	
064	063	064	100	100	100	100	
065	064	065	100	100	100	100	
066	065	066	100	100	100	100	
067	066	067	100	100	100	100	
068	067	068	100	100	100	100	
069	068	069	100	100	100	100	
070	069	070	100	100	100	100	
071	070	071	100	100	100	100	
072	071	072	100	100	100	100	
073	072	073	100	100	100	100	
074	073	074	100	100	100	100	
075	074	075	100	100	100	100	
076	075	076	100	100	100	100	
077	076	077	100	100	100	100	
078	077	078	100	100	100	100	
079	078	079	100	100	100	100	
080	079	080	100	100	100	100	
081	080	081	100	100	100	100	
082	081	082	100	100	100	100	
083	082	083	100	100	100	100	
084	083	084	100	100	100	100	
085	084	085	100	100	100	100	
086	085	086	100	100	100	100	
087	086	087	100	100	100	100	
088	087	088	100	100	100	100	
089	088	089	100	100	100	100	
090	089	090	100	100	100	100	
091	090	091	100	100	100	100	
092	091	092	100	100	100	100	
093	092	093	100	100	100	100	
094	093	094	100	100	100	100	
095	094	095	100	100	100	100	
096	095	096	100	100	100	100	
097	096	097	100	100	100	100	
098	097	098	100	100	100	100	
099	098	099	100	100	100	100	
100	099	100	100	100	100	100	

① - Start of Run  
 ② - Run Number at 2000  
 ③ - Start of Run, Run Analysis  
 ④ - Run Number Analysis  
 ⑤ - Run Number, Run Analysis  
 or not completely substituted.

⑥ - Run Number, Run Analysis  
 ⑦ - Run Number, Run Analysis  
 ⑧ - Run Number, Run Analysis  
 ⑨ - Run Number, Run Analysis  
 ⑩ - Run Number, Run Analysis

2

High temperature aging was performed on all test groups. These tests stimulated adhesive outgassing or physical changes in the adhesive. (Control samples were not subjected to aging environments.)

Forty test specimens were subjected to 180°C for 132 hours between August 17 and 24, 1973. The equivalent hours at 125°C to produce the same polymer aging effects are tabulated below, as well as the hours at 180°C equivalent to 100,000 hours at 125°C.

Material	Equivalent Aging			
	Ablestick 535	Ablefilm 517	Epotek H-31	duPont 5504
Hours at 180°C equivalent to 100,000 hours at 125°C	5,400	345	3,000	1,600
Hours at 125°C equivalent to 132 hours at 180°C	2,450	38,000	4,400	8,200

Fifty-eight other parts (40 plus 18 spares), containing samples from each test groups, were subjected to a 24 hour high temperature storage test at 150°C. This test took place between August 21 and 23, 1973 in accordance with MIL-STD-883, Method 1008, Condition C.

Power burn-in was performed at 125°C for 240 hours, in accordance with MIL-STD-883, Method 1015. Power transistors were powered to maximum ratings and FETs were placed in a reverse bias condition. This test was employed to stimulate adhesive outgassing and accelerate corrosive effects of outgassing. The FETs were placed in reverse bias in order to induce channeling from surface contamination.

The results of electrical measurements taken after burn-in are indicated in Figure 20, a thru j.

This test is valuable in determining whether an adhesive is acceptable, from an outgassing standpoint, for a given circuit.

Power cycling test consisted of 5000 cycles with a  $\Delta T$  of 100°C on the power transistor chips. Appropriate power levels and switching equipment were employed to perform the cycling. In addition to stimulating outgassing and corrosion, this test also provides stresses that will cause loss of bond adhesions through possible expansion coefficient mismatches. Power cycling was conducted between October 24 and 28, 1973. One cycle consists of a power on (1 to 10 sec) and a power off (50 to 60 sec) according to the thermal transfer capabilities of the adhesive used in the package. The average time of 5,000 cycles is approximately 83 hours. The test circuit is shown in Figure 19. S/N 125 (Group 5) and S/N 139 (Group 6) failed this test.

Seventy-six (76) test specimens (70 plus 6 spares) were subjected to three stress producing environments on the dates denoted below. No visually discernible failures occurred. Following these environments, hermeticity tests were conducted.

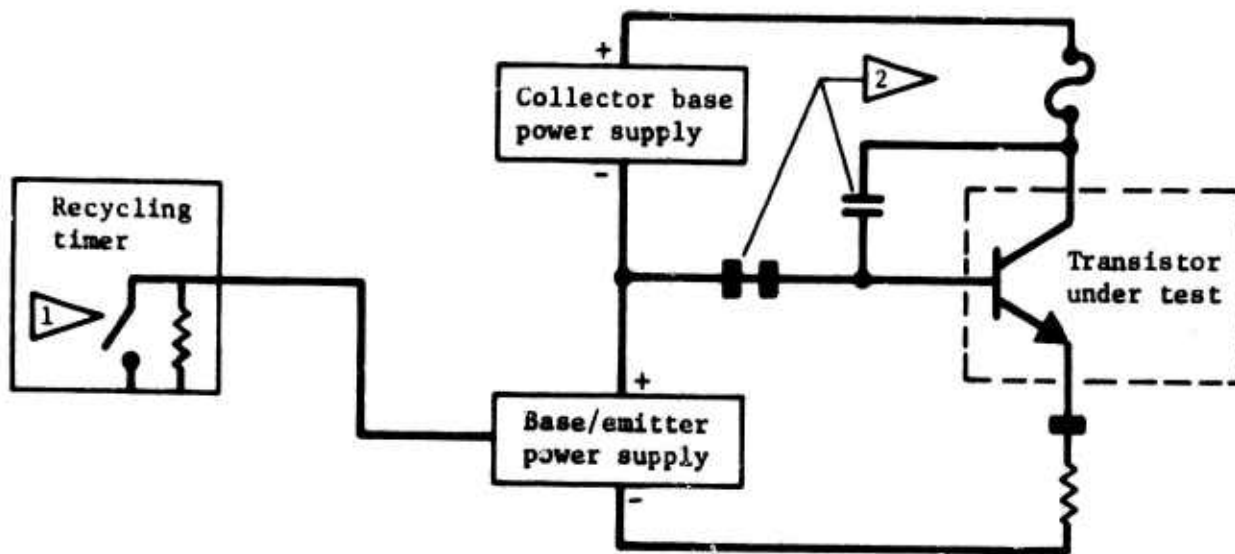

- 1 Recycling timer is connected to remote programming terminals of base/emitter power supply for power cycling.
- 2 Compensating capacitors and ferrite beads were used as required for suppression of possible high frequency oscillations.

Figure 19. Burn-in and power cycling test circuit.

*Thermal shock* was performed in accordance with MIL-STD-883, Method 1011, using Condition A (0 to 100°C) as a minimum. Fifteen cycles with 5 minutes at each extreme were used. Expansion coefficient mismatch possibilities were evaluated by this test in terms of bond and package integrity.

*Mechanical shock* test consisted of five blows in the  $X_1$ ,  $Y_1$ , and  $Z_1$  axes in accordance with MIL-STD-883, Method 2002, Condition B(1500 g). This test was performed in order to evaluate the bond and package mechanical integrity.

*Constant-acceleration* tests were performed in accordance with MIL-STD-883, Method 2001, Condition C (15 Kg). Test duration was one minute in the Y axis only. This test further evaluated the mechanical integrity of substrate, chip, and wire bonds. The final hermeticity and electrical measurement tests following these three environmental tests were designed to identify anomalies caused by the above tests.

*Fine and gross leak tests* were performed in accordance with MIL-STD-883, Method 1014, Conditions A and C. None of the test specimens failed either the fine or gross leak tests following the stress producing environments of shock and centrifuge. The tests were conducted on November 5 and 6, 1973.

*Initial electrical measurement* data were used as a baseline and in the selection phase. The other electrical measurements in the test sequence were used to determine device degradation caused by aging and other environments. The effects of adhesive outgassing and corrosion were reflected in parameter drift because of surface effects. Ten control samples were drawn

from the test devices, as shown in the flow diagram, one from each test group. A control sample was measured each time electrical measurements were taken of the corresponding test group. Data from these samples were used to determine equipment repeatability and to ensure proper interpretation of test data.

The initial electrical measurements were performed in August 1973. The original test plan called for  $V_{CE(SAT)}$  to be measured at 500 mA. It was noted this parameter was out of specification or unstable for all adhesive bonded transistors. The eutectic bonded transistors were generally all within specification. It was then decided to measure  $V_{CE(SAT)}$  for all circuits at 100 mA. This was completed and the parameters were stable and repeatable at this current level. It was believed that the 500 mA current could damage the conductive epoxy and significantly alter the collector resistance.

The four power transistors in each package were tested for  $h_{FE}$ ,  $I_{CEO}$ , and  $V_{CE(SAT)}$ . The four MOSFETS in each package were measured for  $R_{DS(ON)}$ ,  $I_{D(OFF)}$ , and  $I_{GSS}$ . Although all of these measurements were taken at each test interval, only  $V_{CE(SAT)}$  for the bipolar transistor and  $I_{GSS}$  for the MOSFET were used in evaluating bond quality and surface leakages for reasons discussed earlier. The other parameters were taken only so that changes in  $V_{CE(SAT)}$  and  $I_{GSS}$  caused by the effects of the polymers could be differentiated from actual device degradation.

Results of the electrical measurements periodically performed during the test program are presented in Table 9 and Figure 20. Each figure has four curves: a control sample (dotted) and a test specimen  $V_{CE(SAT)}$  curve for the denoted power transistor bond material/seal technique, and a control sample (dotted) and a test specimen  $I_{GSS}$  plot for the MOSFET with the same bond material/seal techniques. The test numbers indicate the position in the test sequence where the electrical measurement was made, and are summarized below.

<u>Test number</u>	<u>Measurement made after</u>
1	Radiographic inspection
2	Aging or storage
3	Power burn-in
4	Power cycling
5	Hermeticity (final measurements)

TABLE 9. HYBRID TESTING SUMMARY

Material	Eutectic		5504		H-31		517		E535	
	-----		DuPont		Epotek		Ablefilm		Ablestick	
Package	Weld	Braze	Weld	Braze	Weld	Braze	Weld	Braze	Weld	Braze
<u>At 100 MA current</u>										
$V_{CE(SAT)}$ initial	0.114	0.113	0.144	0.215	0.381	0.215	0.108	0.186	2.28	1.62
$V_{CE(SAT)}$ burn-in	0.118	0.116	0.152	0.232	0.949	0.447	0.113	0.219	1.83	1.14
$V_{CE(SAT)}$ final	0.120	0.120	0.143	0.234	1.31	0.553	2.83	Fail	2.42	2.04
<u>At 20 V <math>V_{GSS}</math></u>										
$I_{GSS}$ (pA) initial	21	15	16	11	12	17	11	11	16	18
$I_{GSS}$ (pA) burn-in	6	5	13	7	8	9	9	6	26	41
$I_{GSS}$ (pA) final	7	8	15	8	10	10	6	Fail	32	43
<u>At 500 MA current</u>										
$V_{CE(SAT)}$ initial	0.459	0.473	1.241	2.148	---	---	0.494	1.717	---	---
$V_{CE(SAT)}$ final	0.472	0.505	---	---	---	---	1.07	2.40	---	---

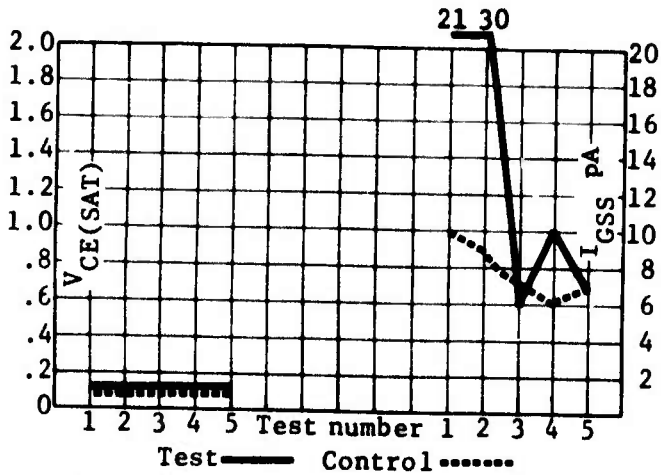

(a) Eutectic substrate bonds.  
Eutectic chip bonds.  
Welded seals.

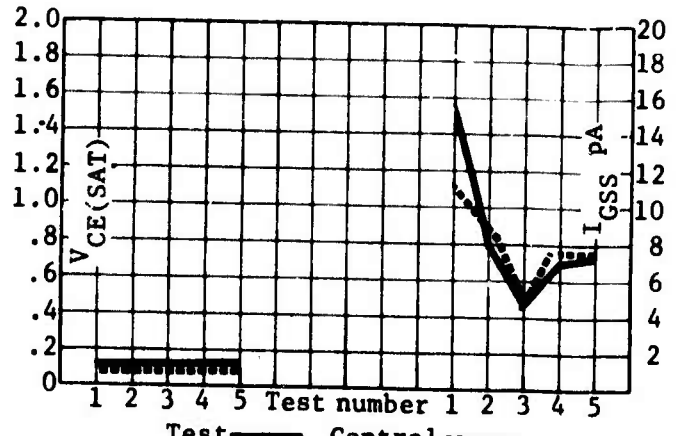

(b) Eutectic substrate bonds.  
Eutectic chip bonds.  
Braze seals.

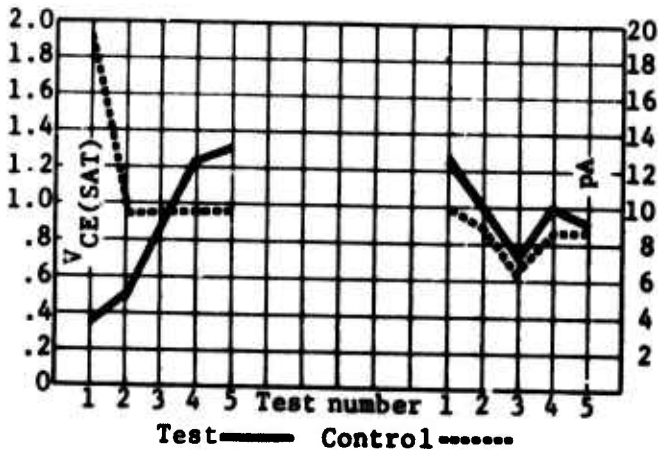

(e) Eutectic substrate bonds.  
Epotek H-31 chip bonds.  
Welded seals.

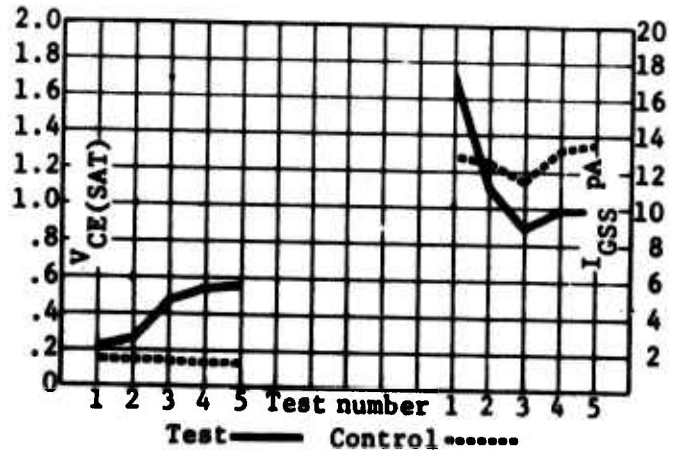

(f) Eutectic substrate bonds.  
Epotek H-31 chip bonds.  
Braze seals.

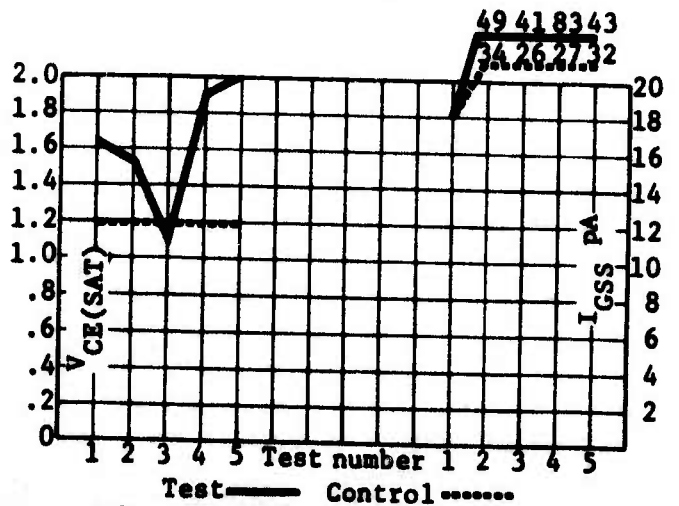

(i) Eutectic substrate bonds.  
Ablestick E535 chip bonds.  
Braze seals

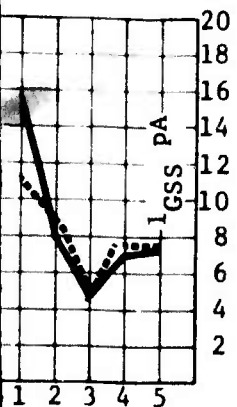

.....  
te bonds.  
nds.

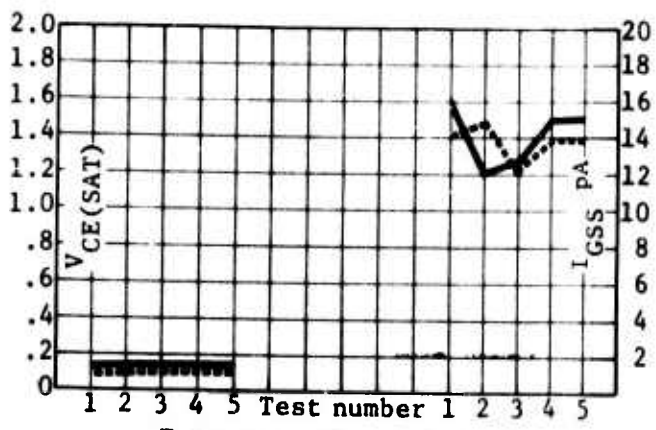

Test—— Control.....  
(c) Eutectic substrate bonds.  
duPont 5504 chip bonds.  
Welded seals.

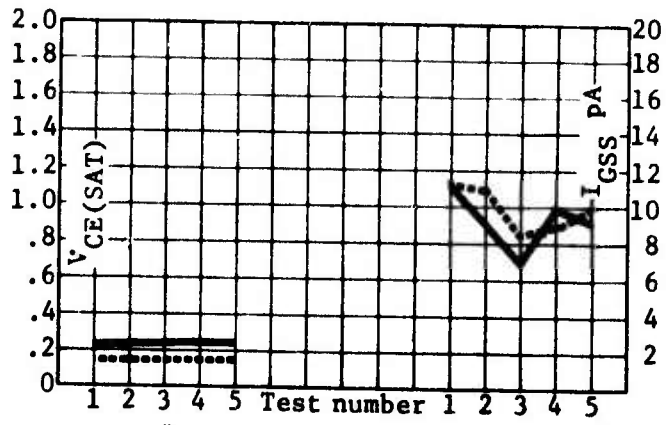

Test—— Control.....  
(d) Eutectic substrate bonds.  
duPont 5504 chip bonds.  
Brazed seals.

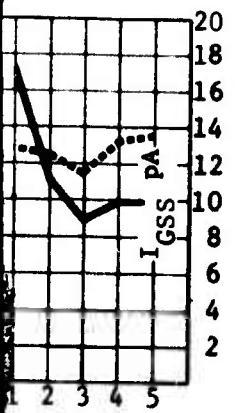

.....  
te bonds.  
bonds.

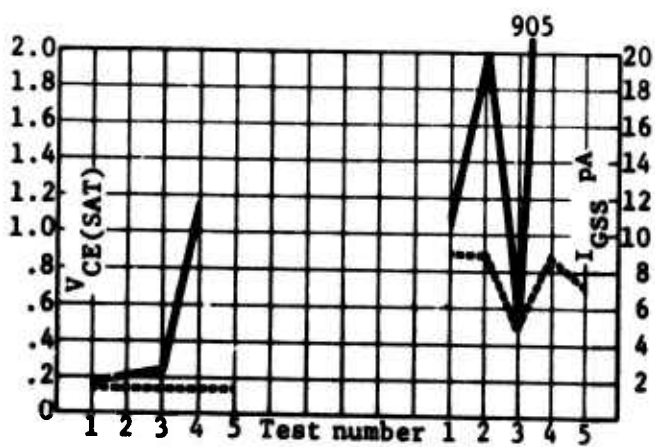

Test—— Control.....  
(g) Ablefilm 317 substrate bonds.  
Eutectic chip bonds.  
Brazed seals.

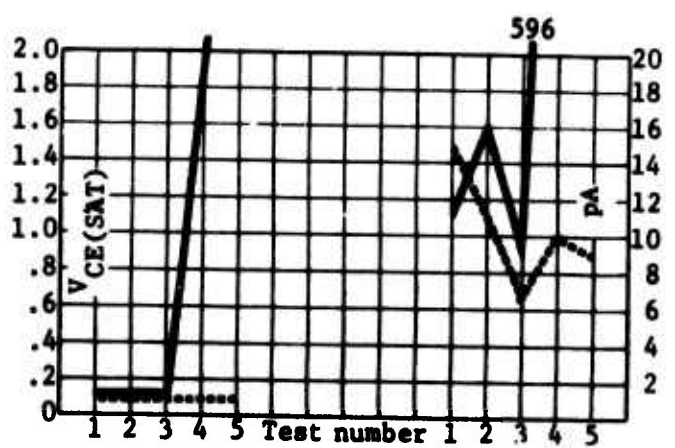

Test—— Control.....  
(h) Ablefilm 517 substrate bonds.  
Eutectic chip bonds.  
Welded seals.

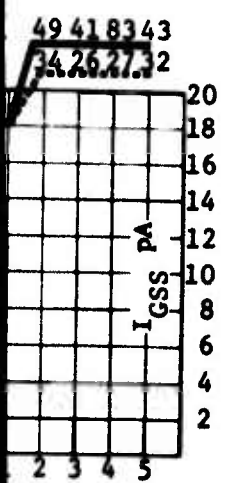

.....  
e bonds.  
ip bonds.

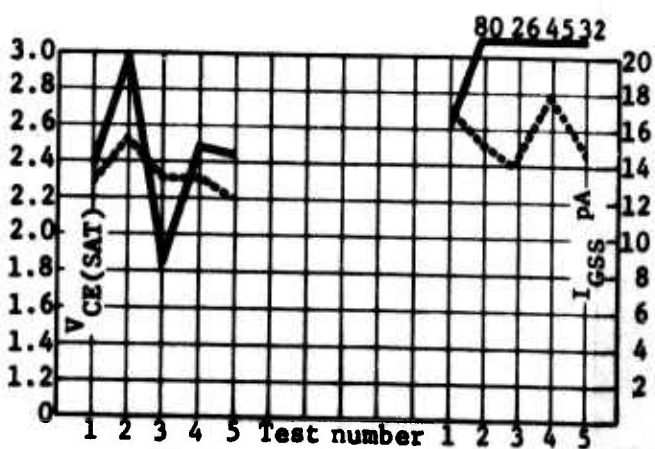

Test—— Control.....  
(j) Eutectic substrate bonds.  
Ablestick E535 chip bonds.  
Welded seals

Figure 20. Electrical measurements

*J*

Table 9 summarizes selected electrical measurement data. Each control sample data point is the average of the four power transistors or the four MOSFETs in the control sample. Each test data point is the average of all functional devices within each of the ten test groups at each point in the test sequence where measurements were made. Catastrophic failures were not included in the data. The number of power transistors or MOSFETs averaged for each data point varied from 26 to 35. The  $V_{CE(SAT)}$  increased for all power transistor test specimens (except the duPont 5504 material/weld seal test specimen) indicating the resistance of the bonding materials increased during the testing. In fact, it compares favorably with the eutectic. Table 9 indicates the eutectic had the least degradation and Ablestick E535 the most degradation.

The increases in MOSFET leakage current  $I_{GSS}$  for the groups indicated in Figure 20, g and h, are indicative of contamination that was driven out of the bonding materials being deposited on the surface of the chip. The graphs demonstrated the correlation between an increase in  $V_{CE(SAT)}$  and the increased leakage, both of which are due to adhesive degradation. The most extensive changes occurred during burn-in. Since the MOSFETs used are extremely sensitive to small amounts of surface contamination, an increase in leakage from 15 to 100 pA represents a surface resistivity of 44 million megohms per square ( $4.4 \times 10^{13} \Omega/\square$ ).

*Thermal shock and power cycling step stress tests* were conducted to assess the effects of high stress and long duration test on polymers. The tests were conducted between November 26, 1973 and January 21, 1974. The thermal shock limits were increased from  $-25^{\circ}\text{C}$  and  $+125^{\circ}\text{C}$  to  $-200^{\circ}\text{C}$  and  $+300^{\circ}\text{C}$  in eight steps consisting of  $25^{\circ}\text{C}$  increments to each temperature extreme. Method 1011 of MIL-STD-883 was utilized, 15 cycles per step, except that the last six steps were air to air. No failures occurred during the thermal shock step stress testing which were performed on samples from each test group. It would appear that the materials tested are thermal-cycle-compatible.

Power cycling step stress was accomplished by performing the test in 5,000 cycle increments until 50,000 cycles accrued. Test specimens of each material/seal group were subjected to the step stress tests. Continuity checks were performed each 5000 cycles. Within the first 5000 cycles, S/N 74 (Group 2C) and S/N 142 (Group 6) failed. S/N 115 (Group 5) indicated degradation occurred between 45,000 and 50,000 cycles. No other failures occurred during this test.

## Failure Analysis

*History* - Hybrid circuits, SN125 from Group 5 and SN139 from Group 6, failed after 2 hours of pulsed power stress cycling. The primary failure experienced by both hybrids was an open circuit failure in each of the power transistors, Q1 through Q4. It was also reported that significant increases had occurred in the MOSFET parameters for Q5 through Q8. It was requested that a failure analysis of these two hybrids be conducted to determine if the failures were the result of electrical overstress during the pulsed power stress cycling or caused by degradation of the hybrid's thermal impedance.

*Cause* - The results of this analysis did not suggest a thermal impedance related failure mode, but it can be shown that the failures probably occurred because of testing anomalies.

*Conclusion* - From the electrical characteristics of the transistors examined, the base wires were fused in a short time period, and the fusing current did not exceed the wire capability by a large amount. If the time period had been an extended duration, more severe parameter degradation would have likely been experienced. And had the fusing current greatly exceeded the wire capability, the amount of wire evaporated would have been much greater.

In light of extensive backchecking into possible test errors, such as emitter resistor shorts and increased base-emitter supply voltage, it is concluded that the most probable cause of the base wire failures was high frequency oscillations. The nature of emitter follower circuits mounted on long leads is often one of parasitic oscillations. The oscillation could produce significant current flow in the base wire under different DC bias conditions. The oscillation results because of the self-inductance in the external base wire resonating in series with the diffusion capacitance of the base-emitter junction.

*Test equipment used* Zeiss EPI-Techniscope; Zeiss Universal M Microscope; Polaroid MP-3 Camera; Tektronix Model 576 Transistor Curve Tracer; Birtcher Model 70 Semiconductor Test Set; Philco IR Microplotter.

### Analysis Method and Disclosure

The hybrid circuits were electrically examined. The dc measurements for SN125 of Group 5 follow.

#### NPN BIPOLAR (2N2987)

#### MOS FET (3N167)

		$R_{DS}$ at $V_{GS} = -20V, I_D = 1 \text{ mA}$	
Q1	Open E to B and B to C	Q5	$R_{DS} = 20 \text{ ohms}$
Q2	Open E to B and B to C	Q6	$R_{DS} = 20 \text{ ohms}$
Q3	Open E to B and B to C	Q7	$R_{DS} = 17 \text{ ohms}$
Q4	Open E to B and B to C	Q8	$R_{DS} = 19 \text{ ohms}$

The dc measurements for SN139 of Group 6 follow.

#### NPN BIPOLAR (2N2987)

#### MOS FET (3N167)

		$R_{DS}$ at $V_{GS} = -20V, I_D = 1 \text{ mA}$	
Q1	Open E to B and B to C	Q5	$R_{DS} = 20 \text{ ohms}$
Q2	Open E to B and B to C	Q6	$R_{DS} = 19 \text{ ohms}$
Q3	Open E to B and B to C	Q7	$R_{DS} = 17 \text{ ohms}$
Q4	Open E to B and B to C	Q8	$R_{DS} = 19 \text{ ohms}$

These data confirm the reported failure conditions.

An external microscopic examination from 10X to 50X did not reveal any package damage or anomalies.

The hybrid packages were opened and internally examined. The NPN transistor failure mode was common for all devices in both hybrid circuits. The base 1-mil aluminum interconnect wire had fused open on each NPN transistor. (See Figure 21.) The transistors that exhibited surface indications of high temperature stress were located in SN139. Individual die to substrate bonds were visually examined and no anomalies were observed. Substrate to package bonds were also examined; however, due to the substrate recess in this package, it was not possible to determine if any separation was present.

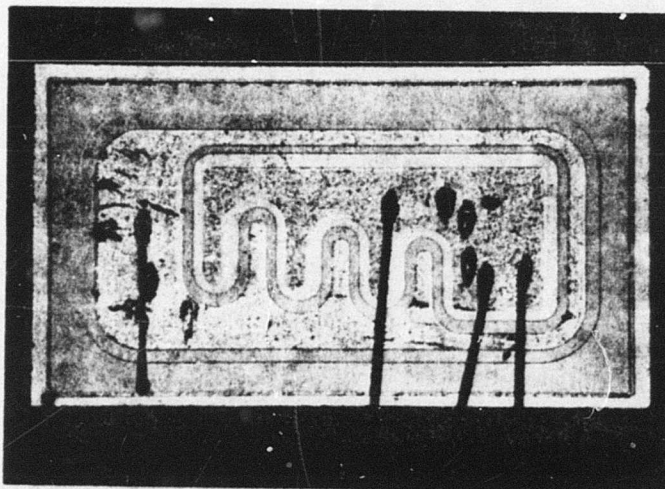

Figure 21. SN125 Group 5, Magnification 50X  
NPN transistor (2N2987) showing base  
interconnect wire (far left) fused open.

The base interconnect wires were replaced to allow further evaluation of the transistor electrical characteristics and package thermal impedances. The electrical parameters and measured data are contained in Table 10. These data do not show severe leakage,  $I_{CEO}$ . The  $H_{fe}$  ( $I_C = 1$  mA) parameter does suggest evidence of degradation. This parameter was not measured before pulsed power cycling so the extent of degradation is not certain. The initial  $H_{fe}$  ( $I_C = 100$  mA) measurements (measured before pulsed power cycling) were:

$$\underline{H_{fe}, V_{CE} = 10V, I_C = 100 \text{ mA}}$$

SN125

Q1 = 59\*, Q2 = 54\*, Q3 = 79, Q4 = 40

TABLE 10. RE-TEST DATA FOR 2N2987 TRANSISTORS,  $T_A = 25^\circ\text{C}$

Device	$BV_{CBO}$ $I_E = 25 \mu\text{A}$	$BV_{EBO}$ $I_E = 25 \mu\text{A}$	$BV_{CLO}$ $I_C = 25 \mu\text{A}$	$I_{CBO}$ $V_{CB} = 90\text{V}$	$I_{EBO}$ $V_{EB} = 7\text{V}$	$I_{CEO}$ $V_{CE} = 50\text{V}$	$H_{fe}$ $V_{CE} = 10\text{V}$ $I_C = 100\text{mA}$	$H_{fe}$ $V_{CE} = 10\text{V}$ $I_C = 1\text{mA}$
Package SN125								
Q1	210 V	12 V	140 V	4.0 NA	1.3 NA	92 NA	69	
Q2	210 V	17 V	165 V	5.0 NA	0.75 NA	5.2 NA	38	
Q3	220 V	13 V	120 V	4.0 NA	1.5 NA	87 NA	98	
Q4	200 V	12 V	220 V	255 NA	210 NA	250 NA	44	
Package SN139								
Q1	200 V	14 V	150 V	1.1 NA	2.2 NA	7.0 NA	90	
Q2	200 V	14 V	200 V	1.2 NA	1.6 $\mu\text{A}$	1.0 NA	38	
Q3	200 V	11 V	140 V	1.5 NA	3.0 NA	1.2 NA	70	
Q4	200 V	11 V	200 V	1.5 NA	105 NA	1.8 NA	98	
Package SN139								
$T_A = 100^\circ\text{C}$								
Q1				19 NA	4.0 NA	275 NA		
Q2				27 NA	1.8 $\mu\text{A}$	3.5 NA		
Q3				15 NA	4.0 NA	1.2 NA		
Q4				12 NA	140 NA	2.2 NA		

SN139

Q1 = 82\*, Q2 = 92, Q3 = 84\*, Q4 = 110\*

$$\underline{I_{CEO}, V_C = 50V}$$

SN125

Q1 = 26 nA, Q2 = 22 nA, Q3 = 30.1 nA, Q4 = 28.5 nA

SN139

Q1 = 4.1 nA, Q2 = 1.6 nA\*, Q3 = 5.3 nA\*, Q4 = 1.0 nA

\*A variation of 10% or greater was experienced between repeated measurements for these transistors.

The two hybrid packages were mounted for thermal impedance measurement. Following the mounting of SN125, it was found that the substrate had separated from the package. Therefore, the thermal impedance tests were performed only on SN139. The tests were performed in the same manner as the sample tests for establishing thermal impedance baselines. The test results were compared to the baseline test unit results (Table 11). The significance of these test results were that the group powered thermal impedance had doubled and the thermal time constant had tripled.

TABLE 11. PULSE LEVEL  $\theta_{JC}$  IN °C/WATT

Q <sub>1</sub>	Q <sub>2</sub>	Q <sub>3</sub>	Q <sub>4</sub>	Q <sub>1</sub>	Q <sub>2</sub>	Q <sub>3</sub>	Q <sub>4</sub>	
Indi- vidual	Indi- vidual	Indi- vidual	Indi- vidual	Q <sub>1</sub> Group	Q <sub>2</sub> Group	Q <sub>3</sub> Group	Q <sub>4</sub> Group	
19.7	17.9	19.3	20.5	20.3	21.0	28.4	24.7	SN132 Baseline
28.7	26.9	26.2	27.2	49.8	42.4	46.9	40.8	SN139 Failed Unit
Comparison		Ref	Fail					
Ind	JC	19.4	27.3					
Group	JC	23.6	45.0					
Time Constant increased 3X								

The substrate of SN125 was lifted away from the package and the two surfaces were microscopically examined. The separation occurred at the interface of the epoxy and the bottom of the package. There was no evidence of epoxy remaining attached. There were thin epoxy film segments that had pulled out of the air pockets and adhered to the bottom of the package (Fig. 22 and 23).

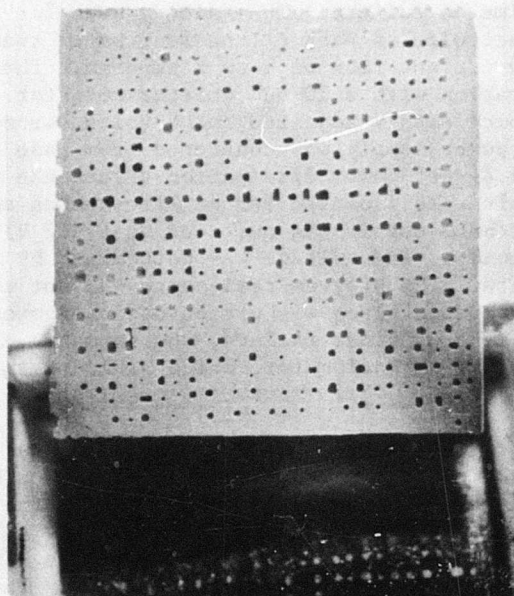

Figure 22. SN125 Group 5, Magnification 5X showing bottom of substrate lifted from package.

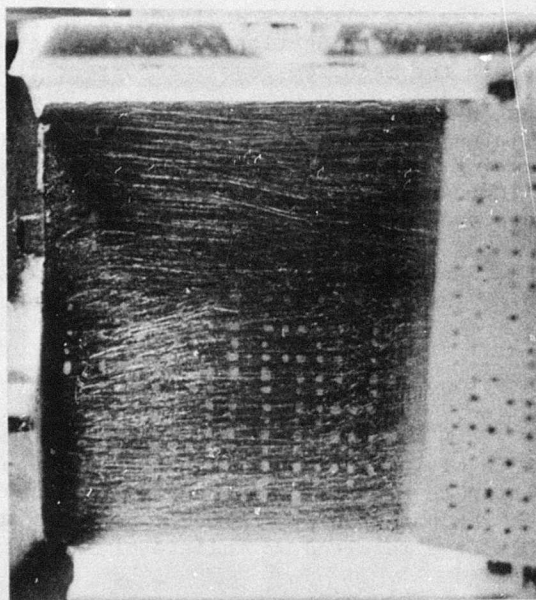

Figure 23. SN125 Group 5, Magnification 5X showing inside bottom of package after removal of the substrate.

The data collected in this analysis were reviewed and related to the test conditions at the time of failure. The failure mode for both circuits was an open base interconnect wire on each of the four power transistors. This would have required a base current flow of 1 to 2 amperes. The test circuit was a common base configuration with a 10-ohm emitter resistor. The base/emitter was driven from a power supply adjusted for 5 volts across the 10-ohm emitter resistor. A second power supply was connected from base to collector and was adjusted to obtain a 4-watt power dissipation across the transistor. Both power supply terminals were isolated for ac line common and the test system common. The emitter/base supply was switched on ( $\sim 5.7$  V) for 4 seconds and off (0 V) for 56 seconds. The voltage was determined by resistor program, i.e., 0 ohms = 0 volts. The program resistance was set using a potentiometer and a relay was switched to place a short across the potentiometer and to remove the short. In case of timer failure, the normally closed contacts would place a short across the potentiometer, which programs the power supply to 0 volts.

The conditions resulting from an increase in thermal impedance were examined first. Based on the degraded thermal impedance measured on SN139, the junction temperatures would have exceeded  $200^{\circ}\text{C}$ . The result would likely have been thermal runaway and excessive emitter current. The indication of the emitter metallization flow shows this to a limited degree, but it did not lead to a shorted die or fused emitter wires. The fact that this did not occur is because of the maximum circuit current of 1.5 amperes through the combination of the transistor and 10 ohm resistor.

Excessive  $I_{\text{CBO}}$  could result in sufficient current to fuse the base wire. However, in the case of the two circuits analyzed, this possibility is not likely because the collector-base junctions do not show evidence of degradation necessary to produce the required level of current flow. ( $I_{\text{CBO}}$  induced failures may have been involved with some of the circuits. It was reported that when circuit failures were first noticed, low level currents,  $\leq 100$  mA, were noticed to be flowing and were independent of the base/emitter supply voltage level. This indicates that emitter-collector current continued after the base wire was fused and was most probably dependent on  $I_{\text{CBO}}$  leakage.)

No cause could be identified that would result in excessive base current flow caused by high junction temperature and the electrical condition of the transistors.

The test configuration was examined for other possible causes that could produce this failure mode.

A possible cause involving the base/emitter power supply was the loss of voltage control resulting in excessive base/emitter current. This would have required an opening in the potentiometer circuit but that was discounted because it would probably have resulted in failure of the total test group.

The failures were noted to have occurred between the points of periodic circuit monitoring and therefore do not suggest a test monitoring error. Nonetheless, the circuit was examined for possible causes involving test monitoring errors. Two possibilities were examined: bypassing of the emitter current sense resistor and introduction of an external source that would result in excessive base current.

Both of these possibilities could not be supported because there was no test circuit common or power line ground within the test circuit loops. Therefore, it would have been necessary to make two connections to the circuit that had a low impedance between them (10 ohms or less) or a potential of 10 volts or greater, and 1 to 2 amperes. In reviewing the equipment used, neither possibility could be established.

A third possibility and the most probable, is that of parasitic high-frequency oscillations. Although no oscillations were detected during the periodic monitoring of the test circuits, analysis of the test circuitry exhibits the situation that very likely existed during transient bias conditions. The equivalent circuit shown in Figure 24 was arrived at in considering the test wiring. It is possible to neglect bulk resistance and stray capacitance because the base diffusion capacitance far exceeds the junction and stray capacitances. The resultant circuit is a series resonant circuit with the load resistance partially bypassed by stray capacitance. Excessive base current is possible when conditions are present to raise the Q of the circuit. A degree of series resonant rise in voltage can occur at the base terminal although the Q normally would be held low due to base resistivity. This type of oscillation is insidious in nature because it can be exaggerated by the use of bypass capacitors and ferrite bead inductors in the wrong places. In this circuit, since the base-emitter supply was switched, oscillation could have occurred during transient bias conditions and could have been missed by the test personnel conducting the tests. The other factor, which tends to support the probability of oscillations is that many circuits were "ganged" in parallel with common supply lines. All the emitter load resistors were connected externally at the end of long wires leading into the ovens.

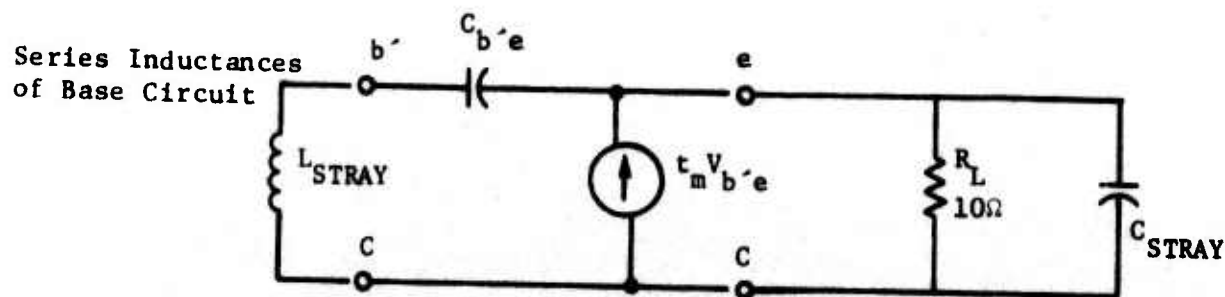

Figure 24. Simplified Model of a Hybrid pi Equivalent

## SECTION VI

### PHASE 5, DEVICE PROPERTY EVALUATION

#### Thermal Conductivity

A major concern in the evaluation of each sample is the thermal conductivity under operating conditions as indicated by junction to case thermal impedance,  $\theta_{JC}$  measured in  $^{\circ}\text{C}/\text{W}$ . A hybrid representing each of the ten various adhesive or eutectic combinations was analyzed for junction to case thermal impedance. Each circuit had a copper constantan thermocouple silver epoxied onto the base of the package to provide a case temperature reading. Interconnecting wires were attached to the package leads in order to power the four power transistors and led to a breakout box. The package, with lid removed, was mounted on an aluminum heat sink using a thermally conductive paste.

The Microradiometer was set on the middle junction of each chip and that chip powered at 20-V collector to emitter ( $V_{CE}$ ) with a variable resistor in the emitter leg. Base to emitter voltage ( $V_{BE}$ ) was applied until the chip indicated approximately  $100^{\circ}\text{C}$ . The chip was manually scanned to find the hottest point, which normally is near the end of the emitter finger at the center of the die. Set at this point, the base drive was set to give a delta of approximately  $100^{\circ}\text{C}$  between the surface temperature and the thermocouple case temperature. Normal resistor value was 10 to 11 ohms. The chip was unpowered by opening the emitter lead and repowered while connected to a 10 sec/inch time base X-Y recorder. At stability, the thermocouple, Radiometer, and input power readings were recorded as was the position of the hot spot. Without changing  $V_{BE}$  or  $V_{CE}$ , each additional die was individually powered and readjusted to give the same temperature increase as the first chip. All chips were then powered in a common base and collector mode and the readings retaken on each chip's hot spot with  $V_{BE}$  reduced to again give approximately a  $100^{\circ}\text{C}$  increase.

Heat sink temperature was then increased to give a case temperature of approximately  $125^{\circ}\text{C}$ .  $V_{CE}$  was reduced in most cases to 10 volts and  $V_{BE}$  adjusted to give a chip temperature increase in an all powered condition of  $15^{\circ}\text{C}$ . Each chip's hot spot was then measured thermally with power applied and power removed. The power removed readings were used to calculate an emissivity at the measured point while the powered readings were used to give a  $\theta_{JC}$  measurement in the burn-in condition. The emissivity numbers were then applied to the pulse data and the  $\theta_{JC}$  under a pulse condition calculated.

In all pulsed conditions, the major factor in the time constant appeared to be the interface between the package and the heat sink. In all cases stability was achieved within 15 seconds, and a pulse of 10 seconds on and 50 seconds off was sufficient to achieve a repeatable pulse condition.

The results are summarized in Table 12,  $\theta_{JC}$  measurements. The order of merit is indicated; the eutectic bonded chips/welded package had the lowest thermal impedance. The duPont 5504A adhesive bonded chip/welded package was best among the adhesive bonded test specimens. Its thermal impedance was only 5% greater for burn-in than the eutectic/bonded/welded package that served as a standard for comparison. The Ablestick E535 had the worst (highest) thermal impedance of those tested.

TABLE 12.  $\theta_{JC}$  MEASUREMENTS

MATERIAL	EUTECTIC		duPont 5504A		Epotek H-31		Ablefilm 517		Ablestick E535		
	SERIAL NUMBER	111	095	061	028	054	007	132	127	078	040
Package	Weld	Braze	Weld	Braze	Weld	Braze	Weld	Braze	Weld	Braze	
$\theta_{JC}$ in °C/W											
Average pulse	11.7	18.5	15.5	20.7	29.6	18.9	23.6	24.2	62.2	49.4	
Average burn-in	15.6	17.9	16.4	19.1	29.8	22.1	24.8	25.8	67.3	47.3	
Order of merit burn-in	1	3	2	4	8	5	6	7	10	9	

#### Gas Analysis

It is known that the use of epoxy adhesives in hybrid circuits can materially affect the composition of the gas hermetically sealed within the package. This is caused by degradation of the polymer into gaseous products and by release of absorbed materials (primarily water) from the epoxy. These contaminant gases may not be present in significant quantity to be harmful when the gas is analyzed immediately after sealing. However, if the circuit is subjected to long term aging at slightly elevated temperature, as in burn-in, materials can be released from the epoxy.

In order to assess the extent of this problem, some circuits were subjected to gas analysis after all testing was complete. The analysis was done at RADC. The technique consists of puncturing the package in a vacuum chamber and analyzing the gases quantitatively by mass spectrometry. No significant conclusions could be drawn from data collected from these tests.

The analysis was performed on circuits that were cleaned and fabricated using the MMC standard methods including a cleaning in deionized water and a vacuum bake of 125°C for one hour. Those circuits fabricated using epoxy adhesives contained from 0.9 to 1.2% water vapor while a circuit fabricated using eutectic contained 0.089% water vapor. It was reasoned that if the deionized water phase of cleaning was eliminated, water could not be absorbed by the epoxy, and that the water vapor content of the circuit packages would be greatly reduced.

More circuits were fabricated and a second analysis was performed. The packages were fabricated in the same way as before but all water was excluded from the cleaning steps and a 5-minute boil in electronic grade 2-Propanol was used instead of deionized water. The vacuum bake was performed as with the first set of packages. This time the analysis showed even more water vapor in the packages. The packages fabricated using adhesives showed from 1.7 to 4.4% water vapor while the package fabricated using a eutectic showed 1.2% water vapor.

These analyses are inconclusive and it is suggested that further testing should be performed in this area on a much larger scale than was possible in this overall study. Tables 13 and 14 give results of these tests.

Water vapor is obviously a potential hazard, especially for thin film resistors; therefore, it would be prudent to take precautions to minimize water contact with adhesive bonded circuits. The possible deleterious effects of organics, CO<sub>2</sub>, and methane are not clearly known, but their presence could be a concern.

TABLE 13. GAS ANALYSIS OF HERMETICALLY SEALED PACKAGES, FIRST TEST

Gas analysis, percent V/V

Adhesive Seal method	H <sub>2</sub>	He	CH <sub>4</sub>	H <sub>2</sub> O	Ar	CO <sub>2</sub>	Mass 78	Freon	Organics
H-31 Braze	0.0250	0.0068	0.0264	3.2	0.0350	0.6	0.0006		
5504 Braze	0.0176	---	---	1.7	0.034	0.4	0.0002		Trace
535 Braze	0.0323	6.2	0.6	1.9	0.2	0.8	0.0019	0.6	Trace
5504 Weld	0.0122	---	0.0038	0.9	0.0970	0.9	0.0005		Trace
535 Weld	0.0679	0.0662	1.0	1.9	0.0926	1.2	0.0033		High
Eutectic Braze	0.0297	0.1	---	0.089	0.0267	0.0509	---		None
517 Weld	0.100	---	0.2	7.2	0.2	2.2		0.0015	High

TABLE 14. GAS ANALYSIS OF HERMETICALLY SEALED PACKAGES, SECOND TEST

Adhesive Seal Method	H <sub>2</sub>	He	CH <sub>4</sub>	H <sub>2</sub> O	Ar	CO <sub>2</sub>	Mass 78	Freon	Organics
H-31 Braze	0.1	--	--	4.4	0.1	0.2	--	--	--
5504 Braze	0.1	--	--	3.2	0.1	0.1	--	--	--
535 Braze	--	--	--	1.7	0.1	0.2	--	--	--
Eutectic Braze	--	--	--	1.2	0.1	0.1	--	--	--
517 Braze	0.5	--	2.3	9.1	0.2	0.9	--	--	--

## SECTION VII

### ADDITIONAL TESTING

Approximately one year after completion of the power burn-in test, additional tests consisting of vidicon examination and electrical measurements were performed on 70 hybrid assemblies returned to Martin Marietta by RADC. These tests were performed to evaluate the effects of shelf aging on epoxy-bonded hybrids and to determine the nature of a number of mechanical failures which had occurred either within or subsequent to the test program. These failures were designated "rattlers" because the hybrid packages contained loose particles of a size which produced an audible rattling sound when shaken. The serial numbers of the rattlers are indicated on Table 8. Also, measurements were performed on the parts which had experienced long term power cycling. Other tests such as die shear tests, gas and chemical analyses, and failure analyses were performed as described below.

#### Vidicon Examination

Vidicon examination of the following serial numbers was performed on October 4, 1974 utilizing a Picker x-ray with Conrack video monitor at 20X magnification:

002	011	023	043*	053*	070	086	102	117*	133*
004	012	027	044*	059*	073	087	105	119*	134*
005	018	032	045	060*	077	088	106	120*	135*
006	019	034*	047	065	080	089	107	121*	136*
008	020	037	048	066	082	091	108	124*	137
009	021	038	049	067	084	094	109	126*	138*
010	022	039	050	068*	085	100	110	131	140*

The serial numbers which evidenced mechanical defects are annotated with a star. These are the rattlers, and in each instance the defect was a loose or broken substrate. It is interesting to note that all serial numbers through 114 contained eutectically bonded substrates and those above 114 contained adhesively bonded substrates. Thus, broken or loose substrates accounted for all rattlers, regardless of the method of substrate bonding.

#### Electrical Measurements

Measurements of  $V_{CE(SAT)}$  and  $I_{GSS}$  were performed on the unstarred serial numbers above. The results are shown in Table 15 along with the final data previously taken for each test group. The previous data is from Table 9, and the numbers presented are average values for each group. The comparison is an indication of drift after a period of dormancy. Group 5 data is missing because all parts from that group listed above were rattlers. It is interesting to note that, although the population of the additional measurements is a subgroup of the previous final measurements, no significant shift is evident except for the Group 6 parts

which had adhesively bonded substrates and eutectically bonded chips. The improvement of  $V_{CE(SAT)}$  in Group 6 data is probably due to the elimination of the rattlers from the test population. Higher  $V_{CE(SAT)}$  values noted for Groups 1C and 2C (Ablestick 535 adhesive), both here and throughout the program (see Table 9) are probably due to the poorer electrical conductivity as well as thermal conductivity (see Table 12) of this epoxy. The  $I_{GSS}$  measurements show marked stability and are well within the specification value of 100 pA.

TABLE 15. ADDITIONAL MEASUREMENTS

Group	$V_{CE(SAT)}$ at 100 mA (Volts)		$I_{GSS}$ at 20 V (pA)	
	Final	Additional	Final	Additional
1A	.553	.541	10	33.2
1B	.234	.256	8	9.4
1C	2.04	2.51	43	65.9
2A	1.31	1.55	10	25
2B	.143	.151	15	5.6
2C	2.42	3.20	32	45.3
3	.120	.123	8	8.6
4	.120	.124	7	6
6	2.83	.550	6	7.5

#### Power Cycling Parts

Long term power cycling had been previously performed on representative samples from each test group. A total of 19 parts were tested, the serial numbers are identified in Table 8. These parts were subjected to Vidicon examination on 27 Aug. 1975 and no mechanical defects or anomalies were detected. No rattlers existed within this group. Electrical measurements of  $V_{CE(SAT)}$  and  $I_{GSS}$  were taken on 14 Aug. 1975 and the data is listed in Table 16, together with the "final" data previously taken for each test group. The numbers presented are average values for each group. It is noted that these measurements were taken approximately 20 months after completion of the power cycling tests. The  $V_{CE(SAT)}$  measurements indicate marked stability after the relatively severe power cycling test followed by the long period of dormancy. Again, the significant exception is in Group 6, adhesively bonded substrate, and again this difference is probably a result of rattlers being included in the "final" data population. The  $I_{GSS}$  values are higher than values measured previously. It may be thought that this could be an effect of epoxy outgassing products condensing on the

chips after power cycling. However, it is noted that Groups 3 and 4 (which contain no adhesives) experienced the same shifts. It is probable, therefore, that these increases in leakage are not a direct result of the use of adhesives. Although this chip was a Siliconix 3N167 MOSFET, similar results\* on RCA MOS technology indicated no adverse effects on stability due to epoxy outgassing products.

TABLE 16. POWER CYCLING PARTS

Group	V <sub>CE(SAT)</sub> at 100 mA (Volts)		I <sub>GSS</sub> at 20 V (pA)	
	Final	Pwr. Cycle Parts	Final	Pwr. Cycle Parts
1A	.553	.221	10	76.5
1B	.234	.185	8	82.1
1C	2.04	1.14	43	157.
2A	1.31	1.23	10	45.4
2B	.143	.152	15	118.3
2C	2.42	1.86	32	104.8
3	.120	.115	8	49.0
4	.120	.122	7	105.4
5	--	.177	-	44.5
6	2.83	.132	6	91.4

#### Additional Failure Analysis

Fifty-two parts were decapped and analyzed to determine causes of electrical and mechanical failure. In summary, electrical failures were generally caused by thermal overstress. This may have been a result of test fixture oscillations or high thermal impedance caused by epoxy die or substrate bonds which resulted in thermal runaway of some parts. This was evidenced by discolorations caused by high temperatures, fused bond wires, reflowed metallization, and localized burning. In particular, Groups 5 and 6, which were fabricated with epoxy bonded substrates, contained the majority of rattlers. A typical part from these groups, S/N 136, is shown in Figures 25 through 27. Figure 25 shows the substrate attached to the preform, but the preform is detached from the case. Evidence of rattling is noted by the bent and broken leads caused by mechanical impact within the case. Evidence of over-power is noted by the base leads which are fused open. Figure 26 is the reverse side of the preform containing the substrate of Figure 25. The areas where adhesion occurred are clearly seen. Figure 27 shows the Tekform case of S/N 136 with the few areas of adhesion showing. Kevex analyses of die surfaces failed to indicate foreign materials. Infrared analyses of the case indicated that some of the stains thereon may have been caused by epoxy thermal outgassing or decomposition products. In one case an organic/ester material was found on a die but the source was probably derived from post-decap handling. The chemical analyses were inconclusive.

\* Richard M. Pietrucha and Eugene M. Reiss: "The Reliability of Epoxy as a Die Attach in Digital and Linear Integrated Circuits." *Reliability Physics, 12th Annual Proceedings, 1974.*

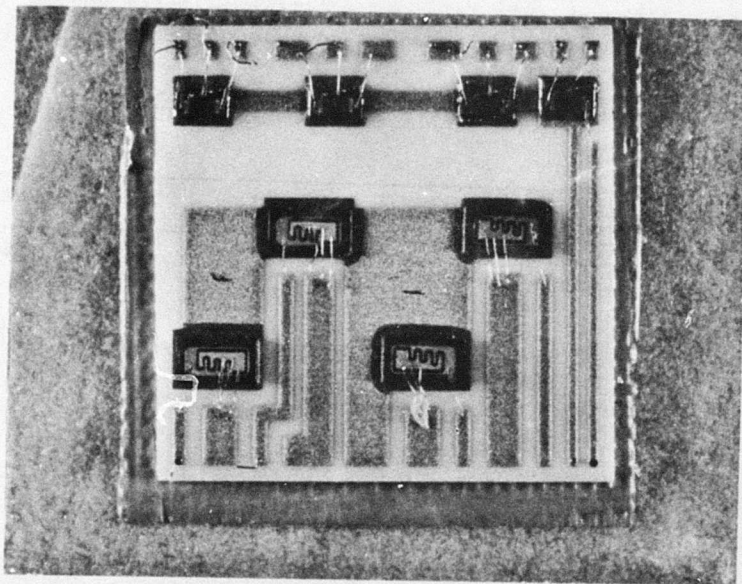

Figure 25. Rattler Pre-form and Substrate, S/N 136

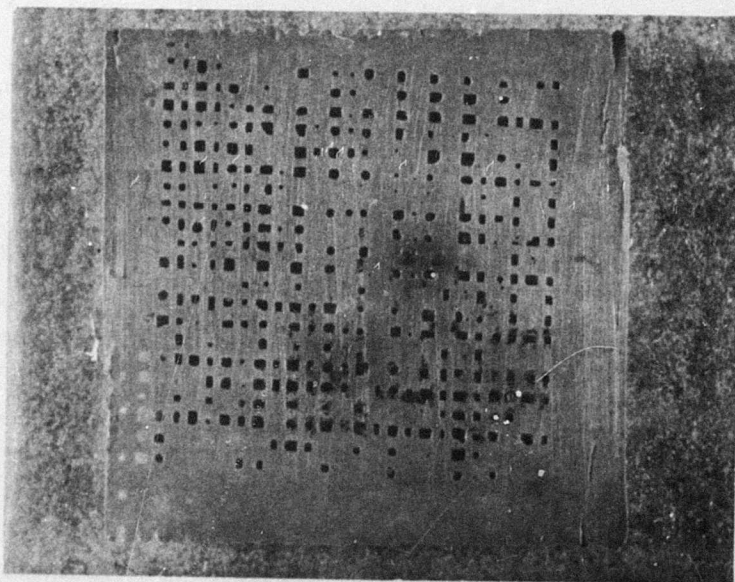

Figure 26. Rattler Pre-form, Rear View, S/N136

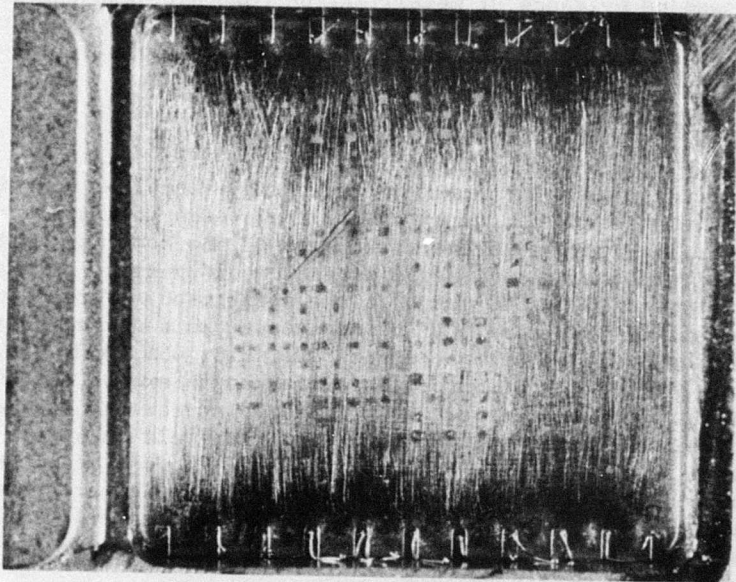

Figure 27. Rattler Case, S/N 136

Specifically, the analyses performed indicated that the mechanical failures in Groups 5 and 6 were caused solely by poor adhesion of the epoxy preform to the package. The mechanical failures in the other groups were also caused by poor substrate to package bonds although they were eutectic. Reliability problems associated with epoxy substrate to package bonds have been experienced and investigated elsewhere\*. The problems occurred with metal-bottomed flatpacks and test results indicated a significant reduction of capability in ceramic to metal bonds as opposed to ceramic to ceramic bonds.

Although the same type of reliability problem with ceramic to metal substrate bonds occurred in the test program herein, it is important to note that package to substrate failures did not adversely affect chip-to-substrate bonds.

A residual gas analysis was made of S/N 045 of Group 2A which evidenced an electrical failure. The mole percent content of gas was as follows:

Nitrogen	99.3
Oxygen	.01
Water	.01
Carbon Dioxide	.16
Methane	.03
Argon	.09
Helium	-
Hydrogen	.44

\* Roger L. Cadenhead: "Substrate Attach Epoxies." *Solid State Technology*, October 1975.

This part showed no evidence of metallization corrosion and the average leakage of the four FET's in the package was 15 pA. Although a transistor had failed there was no evidence that this failure, typically, was due to the use of an epoxy adhesive.

#### Die Shear Tests

Die shear tests were performed on 12 hybrid assemblies containing 96 chips. The tests were performed with a knife edge tool applying a shear stress as shown in Figure 28. The knife edge of the tool was applied to the die edge as uniformly as the die edge surface would permit. The applied force was calibrated up to 500 grams on the scale used. Forces could be applied in excess of 500 grams but the magnitude could not be measured in the tool used. All die on serial numbers 005, 013, 035, 050, 058, 067, 080, 092, 107, 115, 117 and 131 withstood shear forces in excess of 500 grams. At times the die would be crushed when excessive stress resulted at an irregular edge, or when the force was increased until a yield occurred. None of the shears were obtained at the epoxy interface. The die would generally shear within the silicon or be crushed. Some of the die were pried off the substrate with a knife edge. This test showed that the gold waffle pattern would separate from the substrate rather than the epoxy separating from the chip or from the gold waffle pattern.

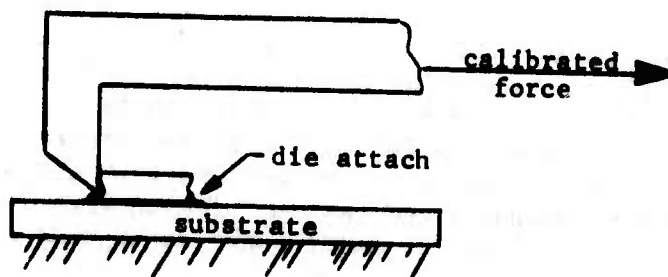

Figure 28. Die Shear Test

The mechanical integrity of epoxy die attach demonstrated in these tests is in support of similar data reported elsewhere\*. Also, further tests and data on the same epoxies tested in this program has led to the conclusion† that the mechanical characteristics of epoxy-attached die are superior to metal die attach. This is reported to be due to the plastic deformation which occurs before failure in the epoxies, which results in accommodation of larger strains than eutectics will allow. This is important when thermal expansion mismatches of bonded parts occur.

\* Op. cit.: Pietrucha and Reiss

† Dr. R. F. David: "Advances in Epoxy Die Attach." *Solid State Technology*, September 1975.

## SECTION VIII

### CONCLUSIONS AND RECOMMENDATIONS

The objective of this study was to evaluate the use of polymer adhesives in microelectronics, with emphasis on chip to substrate bonding applications. The mechanical integrity of chip-to-ceramic substrate bonds was demonstrated in a test program that included 50,000 power cycles and temperature cycling with temperature extremes up to  $-200^{\circ}\text{C}$  and  $+300^{\circ}\text{C}$ . The test vehicles contained both bipolar power transistors and MOSFET transistors. MOSFET devices showed good stability after 20 months of shelf life environment following the rigorous test sequence. No significant adverse effects from epoxy outgassing were evidenced either during the hybrid fabrication process or the test sequence. All processes, such as ultrasonic chip wire bonding, were performed with no change from the standards used for eutectically bonded assemblies.

Failures that were significant in regard to the use of epoxies occurred in the areas of substrate attach and power transistor die attach. The ceramic substrate to metal package epoxy bonds prepared in this program had a number of failures. Some eutectically bonded substrates also failed. It is important to note, however, that the substrate failures were induced with nominal environmental levels used in qualification and screening of microcircuits. Substrates which survived these tests, and which were later subjected to extensive power cycling or thermal shock tests, also survived the extended tests. Constant acceleration of 15,000 G's was adequate to detect poor eutectic and poor epoxy substrate bonds. Power transistor failures were primarily due to a marginal burn-in circuit and high thermal impedances. As compared to eutectic die and substrate bonding, the thermal and electrical conductivities were reduced with the use of epoxies. The power transistor collector resistance indicated instability at 500 mA on two of the epoxies tested. As this is approximately  $23 \text{ A/cm}^2$ , a conservative application limit for this epoxy, chip, and package combination should probably be less than  $20 \text{ A/cm}^2$ . It is significant that no failure, substrate or die related, adversely affected the mechanical integrity of power or MOSFET transistor chip-to-substrate bonds.

In summary, the die bonds were equally reliable on soldered or welded packages, whether subjected to storage tests at  $150^{\circ}\text{C}$  or  $180^{\circ}\text{C}$ , whether used on power transistor or MOSFET chips, after long term dormancy, and after long term power cycling and excessive thermal shock.

It is concluded that the epoxy adhesives used in this study provided positive and reliable chip bonds.

It is recommended that adhesives, in particular the materials used herein, be considered viable candidates for use as chip attach in high reliability low power applications. No special qualification tests are indicated at this time. This recommendation is limited to the technologies tested. Other technologies, such as chips containing thin film resistors, should be evaluated separately.