

UNCLASSIFIED

AD NUMBER

ADB012994

LIMITATION CHANGES

TO:

Approved for public release; distribution is unlimited.

FROM:

Distribution authorized to U.S. Gov't. agencies only; Test and Evaluation; MAY 1976. Other requests shall be referred to Air Force Rome Air Development Center, IRDT, Griffiss AFB, NY 13441.

AUTHORITY

radc, usaf ltr, 22 jan 1980

THIS PAGE IS UNCLASSIFIED

THIS REPORT HAS BEEN DELIMITED
AND CLEARED FOR PUBLIC RELEASE
UNDER DOD DIRECTIVE 5200.20 AND
NO RESTRICTIONS ARE IMPOSED UPON
ITS USE AND DISCLOSURE.

DISTRIBUTION STATEMENT A

APPROVED FOR PUBLIC RELEASE;
DISTRIBUTION UNLIMITED.

✓

(12) (2) J



ADBOI2994

RADC-TR-76-150
Final Technical Report
May 1976

MICROFICHE SCANNER AND REMOTE DISPLAY SYSTEM

EPSCO Labs

DDC
RECEIVED
AUG 24 1976
C

MICROFICHE SCANNER AND REMOTE DISPLAY SYSTEM

AD No. →
DDC FILE COPY

Distribution limited to U. S. Gov't agencies only;
test and evaluation; May 1976. Other requests for
this document must be referred to RADC (IRDT),
Griffiss AFB NY 13441.

ROME AIR DEVELOPMENT CENTER
AIR FORCE SYSTEMS COMMAND
GRIFFISS AIR FORCE BASE, NEW YORK 13441

The photographs of the Cathode Ray Tube (CRT) display are somewhat illegible and not of the highest quality, however they do demonstrate the display capability of the system.

This report has been reviewed and approved for publication.

APPROVED:

David A. Luther

DAVID A. LUTHER
Project Engineer

APPROVED:

Howard Davis

HOWARD DAVIS
Technical Director
Intelligence & Reconnaissance Division

ADDITIONAL

WTS

D.C.

UNCLASSIFIED

JUSTIFICATION

BY

DISTRIBUTION/AVAILABILITY CODES

Dist.

DATE

White Section

Red Section

B

FOR THE COMMANDER:

John P. Huss

JOHN P. HUSS
Acting Chief, Plans Office

Do not return this copy. Retain or destroy.

UNCLASSIFIED

SECURITY CLASSIFICATION OF THIS PAGE (When Date Entered)

19 REPORT DOCUMENTATION PAGE		READ INSTRUCTIONS BEFORE COMPLETING FORM
18 1. REPORT NUMBER RADC-TR-76-150	2. GOVT ACCESSION NO.	3. RECIPIENT'S CATALOG NUMBER
6 4. TITLE (and Subtitle) MICROFICHE SCANNER AND REMOTE DISPLAY SYSTEM	9 5. TYPE OF REPORT & PERIOD COVERED Final Technical Report 1 Jul 75 - 30 Dec 75	6. CONTRACT OR GRANT NUMBER(s) N/A
10 7. AUTHOR(s) Robert A. Botticelli, Donald J. Walker Gerald N. Wallmark	15 8. CONTRACT OR GRANT NUMBER(s) F30602-75-C-0328 new	9. PERFORMING ORG. REPORT NUMBER N/A
10. PROGRAM ELEMENT, PROJECT, TASK AREA & WORK UNIT NUMBERS	11. CONTROLLING OFFICE NAME AND ADDRESS Rome Air Development Center (IRDT) Griffiss AFB NY 13441	
11. CONTROLLING OFFICE NAME AND ADDRESS EPSCO Labs 15 River Road Wilton CT 06897	12. REPORT DATE May 1976	
12. MONITORING AGENCY NAME & ADDRESS (if different from Controlling Office) Same	13. NUMBER OF PAGES 260	
16 AF-2183	17 218304	14. SECURITY CLASS. (of this report) UNCLASSIFIED
15. DECLASSIFICATION/DOWNGRADING SCHEDULE N/A		
16. DISTRIBUTION STATEMENT (of this Report) Distribution limited to U. S. Gov't agencies only; test and evaluation; May 1976. Other requests for this document must be referred to RADC (IRDT), Griffiss AFB NY 13441.		
17. DISTRIBUTION STATEMENT (of the abstract entered in Block 20, if different from Report) Same		
18. SUPPLEMENTARY NOTES RADC Project Engineer: Presented at Conference of Society for Information David A. Luther (IRDT) Display, Los Angeles CA, 5 May 1976		
19. KEY WORDS (Continue on reverse side if necessary and identify by block number) Microfiche Display Solid State Scanner Information Transfer		
20. ABSTRACT (Continue on reverse side if necessary and identify by block number) This report presents the final results of a study to define an information transfer system between a microfiche storage center and a number of remote users. The scope of the program included a parametric/cost study and alternate system and component analysis which resulted in the definition and recommen- dation of an optimized Microfiche Scanner and Remote Display System.		

DD FORM 1 JAN 73 1473 EDITION OF 1 NOV 65 IS OBSOLETE

UNCLASSIFIED

SECURITY CLASSIFICATION OF THIS PAGE (When Date Entered)

409 539

4/B

UNCLASSIFIED

SECURITY CLASSIFICATION OF THIS PAGE(When Data Entered)

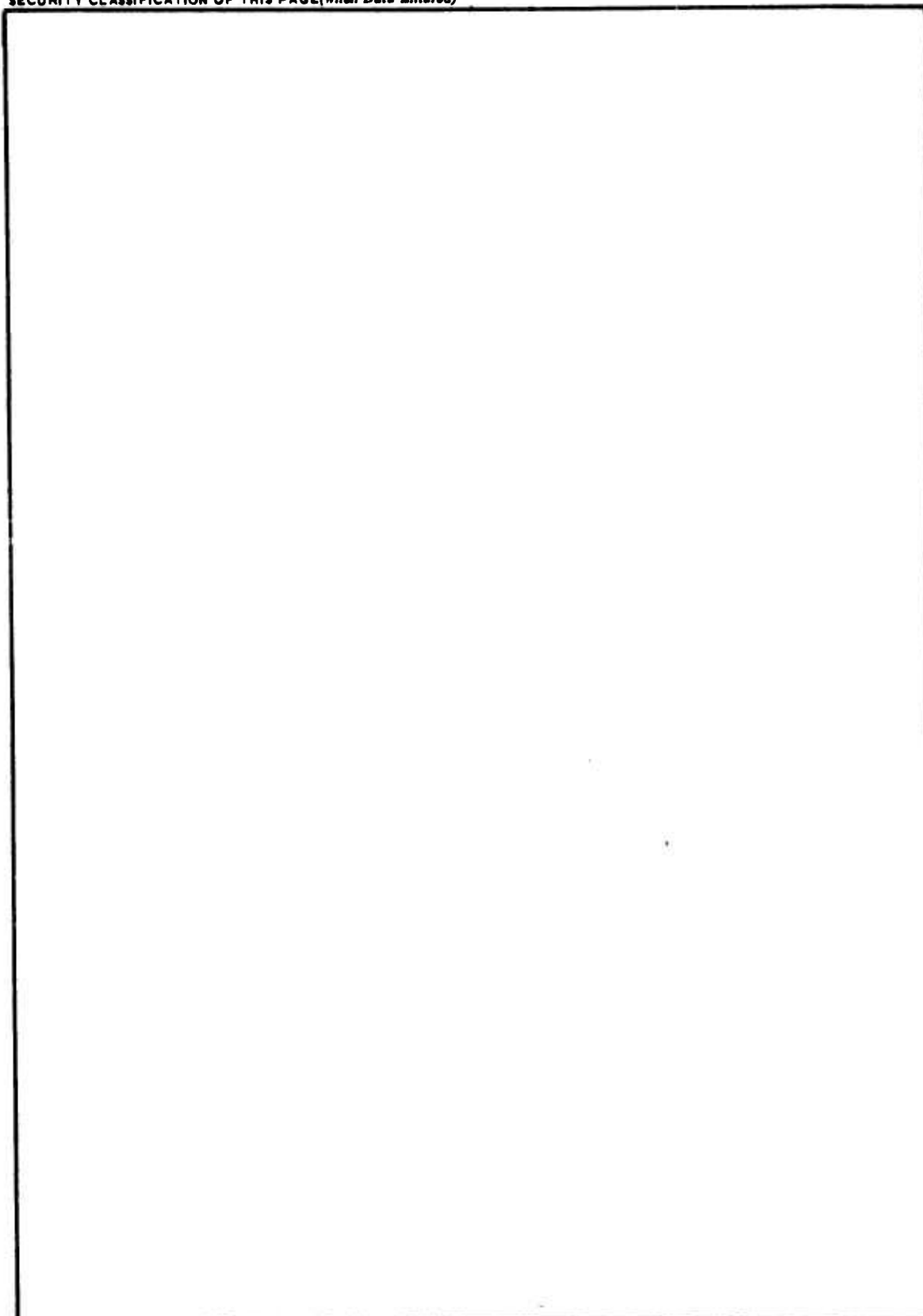

UNCLASSIFIED

SECURITY CLASSIFICATION OF THIS PAGE(When Data Entered)

SUMMARY

The primary purpose of this study was to define an information transfer system which provides a cost-effective and efficient interface between a microfiche storage center and a number of remote users. The problem base was assumed to be the Foreign Technology Division, Wright-Patterson Air Force Base. The scope of the program included a parametric/cost study and alternative system and component analyses which resulted in the recommendation and definition of an optimized "Microfiche Scanner and Remote Display System". The recommended system basically contains solid-state microfiche scanners, a minicomputer with peripheral storage, a coaxial transmission link and remote storage CRT display terminals. The results of laboratory experiments using representative equipment which emphasized the display of microfiche are included.

PREFACE

This final report was prepared by EPSCO Labs, formerly CBS Laboratories, A Division of EPSCO, Incorporated, 15 River Road, Wilton, Connecticut 06897, under Contract No. F30602-75-C-0328, for the Rome Air Development Center, Griffiss Air Force Base, New York 13440. Mr. David Luther of RADC was the Air Force Program Monitor. The work was performed during the period July 1975 through December 1975.

The major EPSCO Laboratories participants and their contributions towards the completion of the contract are given. Robert A. Botticelli was the Program Manager and also performed the display portion of the study. Gerald J. Wallmark investigated the various input scanner possibilities and Donald J. Walker conducted the system analysis and integration part of the program. The experimental effort was conducted by William Harris. A major contribution to the computer and software requirements were made by John Turek.

TABLE OF CONTENTS

SECTION OR PARAGRAPH	TITLE	PAGE
I	INTRODUCTION	1
1.0	BACKGROUND AND STUDY GOALS	1
1.1	ORGANIZATION OF THE VOLUME	2
1.2	CONCLUSIONS AND RECOMMENDATIONS	4
II	DEFINITION OF MICROFICHE SCANNER AND REMOTE DISPLAY SYSTEM FUNCTIONAL REQUIREMENTS	7
2.0	GENERAL	7
2.1	UPGRADING OF FTD INFORMATION RETRIEVAL FACILITIES	7
2.2	MICROFICHE SCANNER AND REMOTE DISPLAY SYSTEM	11
2.3	SYSTEM REQUIREMENTS	12
2.3.1	COMPATIBILITY WITH EXISTING FTD FACILITIES	12
2.3.2	COMPATIBILITY WITH PLANNED FTD FACILITIES	12
2.3.3	GENERAL SYSTEM REQUIREMENTS	12
2.3.4	MICROFICHE DATA BASE	13
2.3.5	MICROFICHE STORAGE CENTER	15
2.3.6	MICROFICHE SCANNER	20
2.3.7	COMPUTER AND MASS STORAGE	21
2.3.8	TRANSMISSION LINK	21
2.3.9	REMOTE	22
2.3.10	DATA COMPRESSION	24
2.4	SYSTEM PARAMETERS	24
2.4.1	LEGIBILITY CRITERIA	25
2.4.2	NUMBER OF PIXELS PER DOCUMENT PAGE	30
2.4.3	ELEMENTS PER PICTURE VERSUS TRANSMISSION TIME	31
2.4.4	PARAMETRIC ANALYSIS	33
III	CANDIDATE EQUIPMENT AND SYSTEM CONFIGURATION SELECTION	37
3.0	GENERAL	37
3.1	MICROFICHE SCANNER	38
3.1.1	DESCRIPTION OF CANDIDATE SCANNING SYSTEMS	38
3.1.1.1	Image Dissector	39
3.1.1.2	Flying Spot Scanner	39
3.1.1.3	Vidicon Camera	39
3.1.1.4	Laser Scanner	41
3.1.1.5	Solid State Scanner	42
3.1.2	SELECTION OF MICROFICHE SCANNING SYSTEM	42
3.1.2.1	Availability	43
3.1.2.2	Performance Analysis	45
3.1.2.2.1	Performance Analysis of the Image Dissector Scanning System	45
3.1.2.2.2	Performance Analysis of the Flying Spot Scanning System	47

TABLE OF CONTENTS

SECTION OR PARAGRAPH	TITLE	PAGE
3.1.2.2.3	Performance Analysis of Vidicon Camera Scanning Systems	47
3.1.2.2.4	Performance Analysis of the Laser Scanning System	49
3.1.2.2.5	Solid State Scanning System	49
3.1.2.2.6	Conclusion	53
3.1.2.3	Cost Analysis	53
3.1.2.4	Reliability and Maintainability Analysis	58
3.1.2.4.1	Reliability Analysis	59
3.1.2.4.2	Maintainability Analysis	59
3.1.2.4.3	Conclusion	66
3.1.2.5	Summary of Candidate Scanning Systems Selection Analyses	66
3.2	DISPLAY TERMINAL	67
3.2.1	DISPLAY TERMINAL SELECTION CRITERIA	67
3.2.2	DISPLAY TERMINAL TYPES AND RECOMMENDATION	69
3.2.2.1	Non-Storage Display	71
3.2.2.2	Direct View Storage Display	73
3.2.2.3	Display Terminal Recommendation	75
3.2.2	BUFFER MEMORY FOR NON-STORAGE CRT DISPLAY	76
3.2.3.1	Memory Types	76
3.2.3.1.1	Magnetic Disc Storage	77
3.2.3.1.2	Magnetic Core Storage	78
3.2.3.1.3	Solid State Random Access Memory	79
3.2.3.1.4	Solid State Shift Registers	79
3.2.3.1.5	Analog Storage Tube	79
3.2.3.2	Refresh Memory Summary	81
3.3	ALTERNATIVE MICROFICHE SYSTEM CONFIGURATIONS	83
3.3.1	BASIC COMMUNICATION ARRANGEMENT	83
3.3.2	POINT-TO-POINT CONFIGURATION	85
3.3.3	MULTI-DROP CONFIGURATION	87
3.3.4	MULTI-DROP CONFIGURATION WITH MULTIPLEXER	91
3.3.5	TERMINAL RANDOM ACCESS CONFIGURATION	93
IV	RECOMMENDED SYSTEM DEFINITION	95
4.0	GENERAL	95
4.1	RECOMMENDED SYSTEM DESCRIPTION AND OPERATION	95
4.1.1	INTERACTIVE LIBRARY ABSTRACT SEARCH	97
	DATA FLOW	
4.1.2	MICROFICHE REQUEST DATA FLOW	97
4.1.3	MICROFICHE STORAGE AND DISPLAY DATA FLOW	99
4.1.4	IMAGE REQUEST FROM PRIMARY STORAGE DATA FLOW	101
4.2	SYSTEM CAPABILITIES	103
4.3	SYSTEM RESPONSE TIME	104
4.4	QUEUING ANALYSIS	105
4.4.1	BASIC QUEUING ANALYSIS METHODOLOGY	105

TABLE OF CONTENTS

SECTION OR PARAGRAPH	TITLE	PAGE
4.4.2	INPUT SCANNER QUEUE	107
4.4.3	TRANSMISSION CHANNEL QUEUE	111
4.5	SYSTEM COMPONENT SPECIFICATIONS	117
4.5.1	COMMUNICATION LINK	117
4.5.1.1	Cable Network Characteristics	117
4.5.1.2	Bandwidth Allocations	119
4.5.1.3	Network Configuration	119
4.5.1.4	Modems	121
4.5.1.4.1	Modem - 9600 Baud	121
4.5.1.4.2	Modem - 48 Kbps	123
4.5.1.4.3	Multiplexer - 48 Kbps	123
4.5.1.4.4	Modem - 300 Kbps Transmit Only	124
4.5.1.4.5	Modem - 300 Kbit Receive Only	125
4.5.1.4.6	Remodulators	125
4.5.1.5	Error Consideration	127
4.5.2	COMPUTER CONFIGURATION	129
4.5.2.1	Microfiche Computer	129
4.5.2.2	Input Processor	131
4.5.2.3	Output Processor	133
4.5.2.4	Microfiche Data Storage	134
4.5.2.5	Memory Organization	135
4.5.2.5.1	Core Data Format	136
4.5.2.5.2	Disk Data Format	136
4.5.2.5.3	Input Processor Core Allocation	137
4.5.2.5.4	Output Processor Core Allocation	137
4.5.2.6	Display Update Time	139
4.5.2.6.1	Analysis of Data Handling Capability	139
	Input Processor	
4.5.2.6.2	Analysis of Data Handling Capability	142
	Output Processor	
4.5.2.7	Concentrator	146
4.5.3	SOFTWARE	146
4.5.3.1	Input Processor Software	147
4.5.3.2	Output Processor Software	150
4.5.3.3	Concentrator Software	151
4.5.3.4	Diagnostic Routines	152
4.5.4	SCANNING SYSTEM	153
4.5.4.1	Scanning System Configuration	153
4.5.4.1.1	Light Source	153
4.5.4.1.2	Vacuum Platen	155
4.5.4.1.3	Transport and Transport Controller	155
4.5.4.1.4	Optical System and Solid State Array	156
	Selection	
4.5.4.1.5	Solid State Array Logic, Drive and	157
	Counting Circuits	

TABLE OF CONTENTS

SECTION OR PARAGRAPH	TITLE	PAGE
4.5.4.1.6	Amplifier and Read Only Memory	159
4.5.4.1.7	Threshold Selector and A/D Converter	159
4.5.4.1.8	Blank Page Detector	159
4.5.4.1.9	Computer Interface	161
4.5.4.1.10	Printer - Keyboard	161
4.5.4.2	Scanning System Packaging Concept	161
4.5.5	INTERFACES	163
4.5.5.1	Scanner - Computer Interface	163
4.5.5.2	Computer - Modem Interface	165
4.5.5.3	Modem - Display Interface	167
4.5.6	DISPLAY TERMINAL	171
V	SYSTEM COST AND IMPLEMENTATION PLAN	173
5.0	GENERAL	173
5.1	ENGINEERING SYSTEM	173
5.2	INITIAL OPERATIONAL CONFIGURATION	175
5.3	FINAL OPERATIONAL CONFIGURATION	175
5.4	SYSTEM IMPLEMENTATION SCHEDULE	175
VI	SUMMARY OF RECOMMENDATIONS AND CONCLUSIONS	179

APPENDICES	TITLE	PAGE
A	MICROFICHE SCANNER PERFORMANCE AND PARAMETRIC ANALYSIS	181
A.0	INTRODUCTION	181
A.1	MODULATION TRANSFER FUNCTION	181
A.1.1	COMPONENT MODULATION TRANSFER FUNCTION	183
A.1.1.1	MTF of Lens	183
A.1.1.2	MTF of Electron Beam	184
A.1.1.3	MTF of Dissecting Aperture	184
A.1.1.4	MTF of Solid State Line Array	185
A.1.1.5	Image Motion MTF	185
A.1.1.6	Image Section, Camera Target and Readout Section MTF's	185
A.1.1.7	Scanner MTF's	186
A.2	DEVELOPMENT OF ANALYTICAL PEAK SIGNAL-TO-RMS NOISE MODELS	187
A.2.1	ANALYTICAL PEAK SIGNAL-TO-RMS NOISE MODEL FOR THE IMAGE DISSECTOR SCANNING SYSTEM	187
A.2.1.1	Output Signal Current	187
A.2.1.2	Output Noise Current	189
A.2.1.2.1	Shot Noise of the Photoelectrons	190
A.2.1.2.2	Noise Due to the Electron Multiplier	191
A.2.1.2.3	Thermal Noise of the Load Impedance	191

APPENDICES	TITLE	PAGE
A.2.2	ANALYTICAL PEAK SIGNAL-TO-RMS NOISE MODEL FOR THE FLYING SPOT SCANNING SYSTEM	192
A.2.2.1	Output Signal Current	192
A.2.2.2	Output Noise Current	195
A.2.2.2.1	Shot Noise of the CRT Electron Beam	195
A.2.2.2.2	Shot Noise of the PMT Photoelectrons	196
A.2.2.2.3	Noise Due to the Electron Multiplier	196
A.2.2.2.4	Preamp Noise	197
A.2.3	ANALYTICAL PEAK SIGNAL-TO-RMS NOISE MODEL FOR THE VIDICON CAMERA SCANNING SYSTEM	198
A.2.3.1	Output Signal Current	198
A.2.3.2	Output Noise Current	200
A.2.3.2.1	Quantum (Image) and Target Noise	201
A.2.3.2.2	Shot Noise Due to the Read Beam	202
A.2.3.2.3	Shot Noise Due to the Target Dark Current	203
A.2.3.2.4	Preamp Noise	203
A.2.4	ANALYTICAL PEAK SIGNAL-TO-RMS NOISE MODEL FOR THE LASER SCANNING SYSTEM	203
A.2.4.1	Output Signal Current	203
A.2.4.2	Output Noise Current	205
A.2.4.2.1	Shot Noise of PMT Photoelectrons and Laser Noise	205
A.2.4.2.2	Noise Due to Electron Multiplier	206
A.2.4.2.3	Preamp Noise	207
A.2.5	ANALYTICAL PEAK SIGNAL-TO-RMS NOISE MODEL FOR THE SOLID STATE SCANNING SYSTEM	207
A.2.5.1	Output Signal Current	207
A.2.5.2	Output Noise Current	208
A.3	ANALYTICAL PEAK-SIGNAL-TO-RMS NOISE MODELS FOR CANDIDATE SENSORS	209
A.4	RELATIONSHIP BETWEEN SCANNER SIGNAL-TO-NOISE RATIO AND OVERALL SCANNER-DISPLAY PERFORMANCE	212
A.4.1	ANALYSIS RELATING SNR TO DIGITIZATION ACCURACY	212
A.4.2	CONCLUSION	215
B	SIMULATION EXPERIMENTS	217
B.0	INTRODUCTION	217
B.1	SIMULATION EXPERIMENTS WITH LIPS AND STORAGE DISPLAY	217
B.1.1	TEST EQUIPMENT	219
B.1.1.1	Laser Image Processing Scanner	219
B.1.1.2	Tektronix #4014 Display Terminal	222
B.1.2	RESOLUTION EXPERIMENTS	223
B.1.2.1	Microfiche Containing Typewritten Documents	223
B.1.2.2	Microfiche Page Containing a Standard Government Form	225
B.1.3	ZOOM EXPERIMENTS	233
B.1.4	MICROFICHE DENSITY VARIATIONS	233
B.1.4.1	Threshold Optimization	239
B.1.5	PULSED WRITING EXPERIMENTS	243

APPENDICES	TITLE	PAGE
B.1.6	WRITING RATE	245
B.1.7	HARD COPY UNIT	247
B.2	SIMULATION EXPERIMENTS WITH CAMERA TUBE AND NON-STORAGE HIGH RESOLUTION DISPLAY	249
B.2.1	DESCRIPTION OF EQUIPMENT	249
B.2.1.1	Light Table	249
B.2.1.2	Focussing Lens	250
B.2.1.3	High Resolution Camera System	250
B.2.1.4	High Resolution, Non Storage Display	250
B.2.2	RESULTS OF SIMULATION	251
B.2.3	CONCLUSION	253
C	DETAILED CONSIDERATION USED IN MAINTAINABILITY NOTICE	255
C.0	INTRODUCTION	255
C.1	CONSIDERATIONS USED IN ESTIMATING PREVENTATIVE MAINTENANCE EFFORT ASSOCIATED WITH EACH SCANNING SYSTEM	255
C.2	CONSIDERATIONS USED IN ESTIMATING CORRECTIVE MAINTENANCE EFFORT ASSOCIATED WITH EACH SCANNING SYSTEM	257

LIST OF ILLUSTRATIONS

FIGURE NUMBER	TITLE	PAGE
2-1	PRESENT MICROFICHE FACILITY FTD	6
2-2	INTERACTIVE ABSTRACT LIBRARY INFORMATION SYSTEM	9
2-3	FUNDAMENTAL BLOCK DIAGRAM OF MICROFICHE SCANNER AND REMOTE DISPLAY SYSTEM	10
2-4	INTERNATIONAL MICROFICHE STANDARD	14
2-5	EXCELLENT QUALITY MICROFICHE SAMPLE FROM FTD DATA BASE	16
2-6	FAIR QUALITY MICROFICHE SAMPLE FROM FTD DATA BASE	17
2-7	POOR QUALITY MICROFICHE SAMPLE FROM FTD DATA BASE	18
2-8	MICROFICHE STORAGE CENTER	19
2-9	LEGIBILITY RESEARCH	26
2-10	SCAN LINES VERSUS CHARACTER HEIGHT	28
2-11	MICROFICHE SCANNER PARAMETRIC ANALYSIS	34
3-1	SCANNER SYSTEM - GENERAL BLOCK DIAGRAM	36
3-2	SCHEMATIC DIAGRAMS OF CANDIDATE SCANNING SYSTEMS	40
3-3	PERFORMING CURVES OF CANDIDATE SCANNING SYSTEMS	44
3-4	LASER SCANNING SYSTEM BLOCK DIAGRAM	54

LIST OF ILLUSTRATIONS

FIGURE NUMBER	TITLE	PAGE
3-5	SOLID STATE SCANNING SYSTEM BLOCK DIAGRAM	55
3-6	FLYING SPOT SCANNING SYSTEM BLOCK DIAGRAM	56
3-7	RELIABILITY ANALYSIS FOR LASER SCANNING SYSTEM	60
3-8	RELIABILITY ANALYSIS FOR FLYING SPOT SCANNING SYSTEM	61
3-9	RELIABILITY ANALYSIS FOR SOLID STATE SCANNING SYSTEM	62
3-10	DISPLAY TERMINAL - GENERAL BLOCK DIAGRAM	68
3-11	TEKTRONIX #4014 DISPLAY TERMINAL TARGET STRUCTURE	72
3-12	TEKTRONIX STORAGE DISPLAY RESOLUTION	74
3-13	SYSTEM BLOCK DIAGRAM - GENERAL	82
3-14	POINT-TO-POINT CONFIGURATION	86
3-15	MULTI-DROP SYSTEM CONFIGURATION	88
3-16	MULTI-DROP SYSTEM CONFIGURATION WITH MULTIPLEXER FOR 48 Kbps MODEMS	90
3-17	SYSTEM CONFIGURATION WITH DYNAMIC CHANNEL ALLOCATION	92
4-1	MICROFICHE SCANNER AND DISPLAY SYSTEM BLOCK DIAGRAM	94
4-2	INTERACTIVE LIBRARY ABSTRACT SEARCH	96
4-3	DATA FLOW - MICROFICHE REQUEST	98
4-4	DATA FLOW - STORAGE AND DISPLAY FROM MICROFICHE	100
4-5	DATA FLOW - DISPLAY FROM PRIMARY STORAGE	102
4-6	QUEUE AT THE INPUT SCANNER	108
4-7	INPUT QUEUING PARAMETERS	108
4-8	QUEUING ANALYSIS AT INPUT SCANNER - MEAN NUMBER OF USERS IN THE QUEUE	110
4-9	QUEUING ANALYSIS AT INPUT SCANNER - MEAN QUEUING TIME	112
4-10	QUEUING AT THE TRANSMISSION CHANNEL	113
4-11	TRANSMISSION CHANNEL QUEUING PARAMETERS	113
4-12	QUEUING ANALYSIS AT TRANSMISSION CHANNELS MEAN NUMBER OF USERS IN THE QUEUE	114
4-13	QUEUING ANALYSIS AT TRANSMISSION CHANNELS MEAN QUEUING TIMES	116
4-14	NETWORK CONFIGURATION	118
4-15	48 KBit/SECOND MULTIPLEXER	122
4-16	VARIABLE FREQUENCY MODEM - BLOCK DIAGRAM	126
4-17	COMPUTER - BLOCK DIAGRAM	130
4-18	COMPUTER - CORE ALLOCATION	138
4-19	SOFTWARE FLOW CHART	148
4-20	SOLID STATE SCANNING SYSTEM BLOCK DIAGRAM	154
4-21	SOLID STATE SCANNING SYSTEM OPTICAL SYSTEM - ARRAY CONFIGURATION	158

LIST OF ILLUSTRATIONS

FIGURE NUMBER	TITLE	PAGE
4-22	CONCEPTUAL SKETCH OF SOLID STATE SCANNING SYSTEM	160
4-23	SCANNER/COMPUTER INTERFACE - BLOCK DIAGRAM	162
4-24	COMPUTER/MODEM INTERFACE - BLOCK DIAGRAM	166
4-25	HIGH SPEED MODEM - DISPLAY INTERFACE	168
4-26	TEKTRONIX #4014-1 DISPLAY OUTLINE DIMENSIONS	170
5-1	ENGINEERING SYSTEM CONFIGURATION	174
5-2	SYSTEM IMPLEMENTATION SCHEDULE	176
A-1	SIGNAL PROBABILITY CONCEPT	214
B-1	SIMULATION EXPERIMENTS TEST EQUIPMENT DISPLAY TERMINAL AND LIPS SCANNER	218
B-2	PHOTOGRAPH OF SIMULATION EXPERIMENT TEST EQUIPMENT	220
B-3	LASER IMAGE PROCESSING SCANNER	221
B-4	LASER IMAGE PROCESSING SCANNER (LIPS) BLOCK DIAGRAM	221
B-5	PHOTOGRAPH OF AN OPTICALLY ENLARGED MICROFICHE PAGE OF A TYPEWRITTEN DOCUMENT	224
B-6	MICROFICHE PAGE PHOTOGRAPH OF A TYPEWRITTEN DOCUMENT DISPLAYED ON AN OPTICAL VIEWER	226
B-7	MICROFICHE PAGE OF A TYPEWRITTEN DOCUMENT DISPLAYED ON THE #4014 TERMINAL (1600 ELEMENTS/ LINE)	227
B-8	MICROFICHE PAGE OF A TYPEWRITTEN DOCUMENT DISPLAYED ON THE #4014 TERMINAL (800 ELEMENTS/ LINE)	228
B-9	PHOTOGRAPH OF AN OPTICALLY ENLARGED MICROFICHE PAGE OF A STANDARD GOVERNMENT FORM	229
B-10	MICROFICHE PAGE PHOTOGRAPH OF A STANDARD GOVERNMENT FORM DISPLAYED ON AN OPTICAL VIEWER	230
B-11	MICROFICHE PAGE OF A STANDARD GOVERNMENT DOCUMENT DISPLAYED ON THE #4014 TERMINAL (1600 ELEMENTS/LINE)	231
B-12	MICROFICHE PAGE OF A STANDARD GOVERNMENT DOCUMENT DISPLAYED ON THE #4014 TERMINAL (800 ELEMENT/LINE)	232
B-13	PHOTOGRAPH OF MICROFICHE PAGE WITH SMALL SUB- SCRIPTS AND GRAPHS	234
B-14	MICROFICHE PAGE WITH SMALL SYMBOLS AND GRAPHS DISPLAYED ON THE #4014 TERMINAL	235
B-15	2X ZOOM MAGNIFICATION OF MICROFICHE PAGE DISPLAYED	236
B-16	2X ZOOM MAGNIFICATION OF MICROFICHE PAGE DISPLAYED	237
B-17	ANALOG SIGNAL AMPLITUDE VARIATIONS CAUSED BY MICROFICHE DENSITY VARIATIONS	238
B-18	THRESHOLD DETECTOR AND A/D CONVERTER BLOCK DIAGRAM	240

LIST OF ILLUSTRATIONS

FIGURE NUMBER	TITLE	PAGE
B-19	THRESHOLD CIRCUIT TIMING WITH FIVE ELEMENT DELAY	240
B-20	DISPLAY RESOLUTION DURING PULSED WRITING EXPERIMENTS	242
B-21	DISPLAY SHOWING RESULTS OF PULSED WRITING	244
B-22	PHOTOGRAPH OF HARD COPY SHOWING DISPLAYED PAGE OF FIGURE B-15	246
B-23	PHOTOGRAPH OF HARD COPY OF DISPLAYED PAGE WITH HALF-TONE PICTURES	248
B-24	RECONSTRUCTED MICROFICHE PAGE	252

LIST OF TABLES

TABLE NUMBER	TITLE	PAGE
2-1	RATIONALE - NUMBER OF PIXELS PER DOCUMENT PAGE	30
2-2	ELEMENTS PER PICTURE VERSUS TRANSMISSION TIME	32
2-3	SYSTEM PARAMETRIC LIST	35
3-1	DATA USED IN GENERATING PERFORMANCE CURVE FOR IMAGE DISSECTOR SCANNING SYSTEM	46
3-2	DATA USED IN GENERATING PERFORMANCE CURVE FOR FLYING SPOT SCANNING SYSTEM	48
3-3	DATA USED IN GENERATING PERFORMANCE CURVES FOR VIDICON CAMERA SCANNING SYSTEMS	50
3-4	DATA USED IN GENERATING PERFORMANCE CURVE FOR LASER SCANNING SYSTEM	51
3-5	DATA USED IN GENERATING PERFORMANCE CURVE FOR SOLID STATE SCANNING SYSTEM	52
3-6	SCANNING SYSTEMS COST MATRIX	57
3-7	SUMMARY OF MAINTAINABILITY ANALYSIS	63
3-8	COMMERCIAL HIGH RESOLUTION CRT DISPLAYS	70
3-9	CRT REFRESH MEMORY CANDIDATES	80
4-1	SYSTEM RESPONSE TIME	104
4-2	VALUES OF PROBABILITY THAT ALL M SERVERS ARE BUSY	109
A-1	COMPONENT MTF'S FOR SCANNERS	186
C-1	MAINTENANCE TASKS AND MAINTENANCE HOURS COMMON TO THE THREE CANDIDATE SCANNING SYSTEMS	255
C-2	MAINTENANCE TASKS AND MAINTENANCE HOURS UNIQUE TO THE THREE CANDIDATE SCANNING SYSTEMS	256
C-3	T_{CM} ANALYSIS FOR LASER SCANNING SYSTEM	258
C-4	T_{CM} ANALYSIS FOR FLYING SPOT SCANNING SYSTEM	259
C-5	T_{CM} ANALYSIS FOR SOLID STATE SCANNING SYSTEM	260

EVALUATION

The effort reported herein was initiated at the request of the Air Force Foreign Technology Division in an attempt to find a more efficient mechanism for communication of scientific and technical material stored in microfiche. The consumers of microfiche, in this case, are technical intelligence analysts.

To simplify matters, two conditions were imposed on the problem. It was to be assumed that microfiche were to be retrieved and refiled by manual means. It was further assumed that the microfiche library and its users were in close proximity, i.e., within several thousand feet.

The key to the problem addressed by this study, in my opinion, is display quality and text legibility. This report addresses that issue, first, on a theoretical basis. However, I felt that subjective user reaction was essential to substantiate display acceptance.

With that basis, it is particularly impressive that the Tektronix #4014 Storage Tube Display received such excellent ratings, both on paper and during simulations. Of course, once it was determined that the 4014 could meet the visual requirements, the fact that it has inherent storage pays great additional dividends. This is especially true when upwards of 100 terminals are needed. The utility of the Tektronix 4014 in this application has to be the most significant discovery of this effort.

The analytic process used by EPSCO to determine and recommend system components was most interesting. Their "parametric analysis" was used to balance the interrelated variables in coming to a final recommendation.

David A. Luther
DAVID A. LUTHER
Project Engineer

SECTION I
INTRODUCTION

1.0 BACKGROUND AND STUDY GOALS

This report presents the technical results of the "Microfiche Scanner and Remote Display System Definition Study", performed by EPSCO Labs, Wilton, Connecticut, for the Rome Air Development Center, Griffiss Air Force Base, under Contract No. F30602-75-0328. The study was performed over a 6-month period from July 1975 through December 1975. This is the final report of the study.

The basic objective of this study was to define an information transfer system providing a cost-effective and efficient interface between a microfiche storage center and a number of remote microfiche users.

Emphasis during the study was placed on resolving the basic feasibility issue as to whether a suitable "soft" display terminal could be used to produce high quality legible displays of microfiche documents.

The problem base for this study was the microfiche data base resident at the Foreign Technology Division (FTD), Wright-Patterson Air Force Base, Ohio, for the purposes of system definition, general requirements and physical constraints. However, it is clear that the system recommendations herein may have a general appeal to other similarly configured problem areas.

At the Foreign Technology Division, significant volumes of data are, and new data will continue to be, stored in a microfiche form. These microfiche are located in a central library. FTD analysts or users often are

made aware of the existence of available microfiche through the use of a computer-based abstract system. Many times the user may seek access to one or a few pages within a single or multiple microfiche. The efficient utilization of the microfiche storage medium and the storage library, as well as the user's time, is best served when he can view his selected data in a minimum time while remaining at or near his work station. The electrical transfer of data from the fiche at a central location to a display terminal at the user's work station offers a reasonable cost effective way of satisfying this need.

The scope of this work included a parametric/cost study and alternative component and system configuration analyses which resulted in the recommendation of an optimized "Microfiche Scanner and Remote Display System". This study included the results of laboratory experiments using representative equipment which emphasized the display of microfiche from the FTD data base. The study does not address any aspect related to automatic microfiche retrieval and refile equipment or techniques. Manual loading of the scanner is assumed at the microfiche storage center.

1.1 ORGANIZATION OF THE VOLUME

The organization of the study results are presented in this Final Report in the following manner.

Section 2 presents a preliminary description of the Microfiche Scanner and Remote Display System required by FTD. The system's functional design requirements/constraints and system parameters are established.

Section 3 examines the major system components and presents the selection rationale. Alternative system configurations are also treated and equipment recommendations are established.

Section 4 presents a detailed description of the recommended Microfiche Scanner and Remote Display System. This discussion contains performance and functional specifications that may be extracted for procurement.

Section 5 summarizes a system implementation plan which includes the schedule and cost required for installation of an operational system at FTD.

Section 6 summarizes the recommendations and conclusions of the study.

Appendix A contains the detailed scanner performance and parametric analysis. The analytical signal-to-noise ratio models used in the analysis are presented.

Appendix B presents the results of the experimental simulation experiments. Tests were conducted using a laser scanner to scan samples of the FTD data base which were displayed on a Tektronix Model 4014 Display Terminal. In addition, other tests were performed using a high-resolution non-storage display for comparison.

Appendix C contains the detailed maintainability analysis related to the various scanner candidates.

1.2 CONCLUSIONS AND RECOMMENDATIONS OF THE STUDY

The major conclusions and recommendations of the study are summarized below:

- Based on the results of analyses and simulation experiments conducted during the study, it has been concluded that the Microfiche Scanner and Remote Display System is feasible. The system will provide an efficient and cost-effective interface between a microfiche storage center and remote microfiche users. EPSCO Labs recommends full implementation of the system at FTD.
- EPSCO Labs recommends a two step implementation plan leading to the installation and acceptance of the Microfiche Scanner and Remote Display System at FTD. A phased procurement will minimize the risk exposure to the government and spread cost expenditures.
- A primary concern at the offset of the study was the ability of available display units to produce highly legible displays of microfiche documents. On the basis of actual simulation demonstrations, it has been concluded that the Tektronix Model #4014 Direct View Storage Display Terminal fully meets the demanding viewing requirements. The Terminal was recommended based on an overall assessment including other analyses.
- A solid state scanner was recommended as the microfiche digitizer, based on an overall assessment of performance, cost, reliability and maintainability.

- The FTD microfiche data base contains a variety of textual documents of different quality levels and letter heights ranging down to about 0.025 inch. A system "zoom" capability is recommended so that a 2:1 magnification of the image size can be obtained at the display. This results in a doubling of the effective resolution so that the smallest symbol sizes can be clearly displayed.

- Although excellent results were obtained displaying "zoomed" images, the adverse effect of microfiche film density variations across extremely small characters and fine grid lines was evident. It is apparent that the legibility of these characters is affected by the threshold level used in digitizing the analog signal obtained from the microfiche scan. It is recommended that the thresholding problem should be studied and circuitry developed in order to optimize the legibility of poor quality microfiche originals containing excessive density variations.

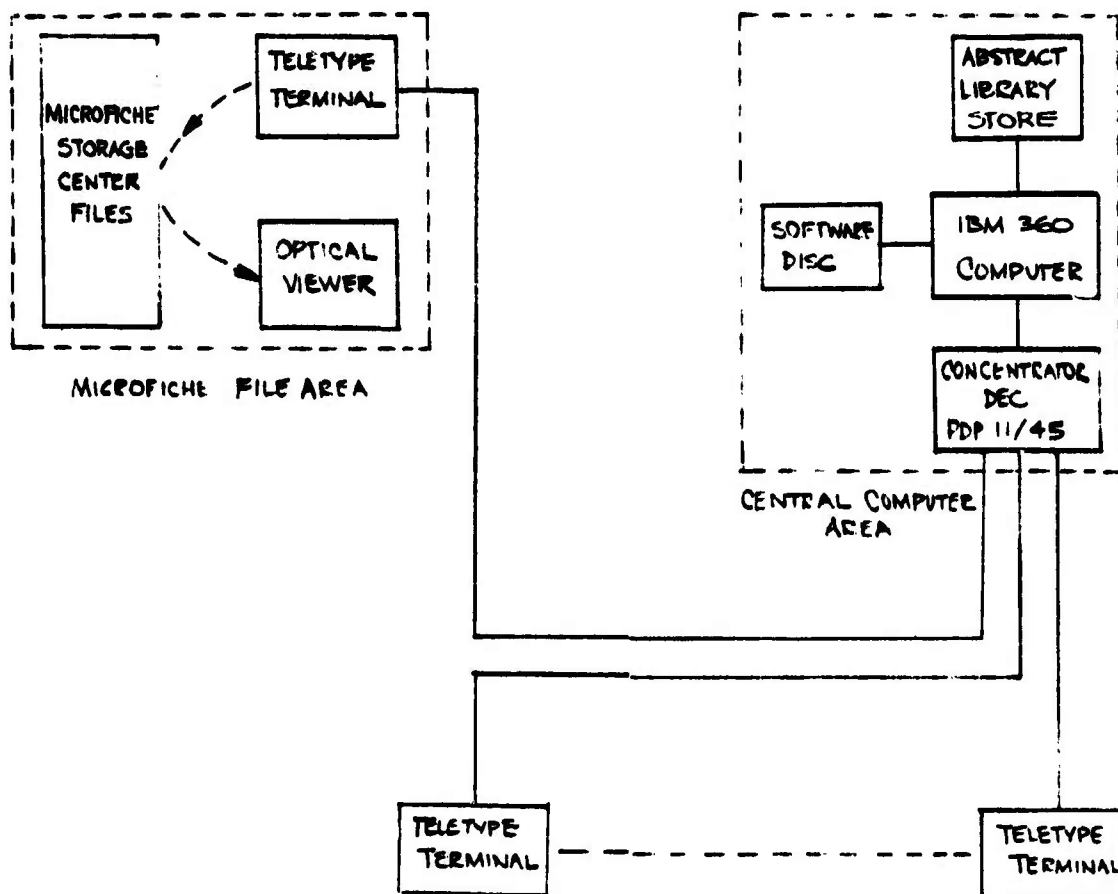

PRESENT MICROFICHE FACILITY AT FTD

FIGURE 2-1

SECTION II
DEFINITION OF MICROFICHE SCANNER & REMOTE
DISPLAY SYSTEM FUNCTIONAL REQUIREMENTS

2.0 GENERAL

This section presents a preliminary description of the Microfiche Scanner and Remote Display System (also referred to as the Microfiche System) required by the Foreign Technology Division at Wright-Patterson Air Force Base. The system's functional design requirements and system parameters are established. This preliminary definition is based on the program statement of work, discussions with RADC and FTD personnel with regard to the needs of the user community, and other information available at the offset of the program.

2.1 UPGRADING OF FTD INFORMATION RETRIEVAL FACILITIES

In recognition of the continuing growth in the use of microfiche, and the realization that it may well become the dominant medium for document storage in the 1980's, FTD has started to upgrade their information retrieval facilities and are investigating the feasibility of installing a Microfiche Storage and Remote Display System.

The microfiche facility at FTD presently is a manual system which must be upgraded if large quantities of microfiche are to be used effectively by the analyst community. Figure 2-1 illustrates how users currently acquire and read microfiche documents. A user first conducts an abstract search using teletype

terminals that are located in various departments within the FTD building. The analyst obtains a list of relevant document titles and abstracts by interactive dialogue with the Abstract Library Information System. The abstract library is essentially part of a large information retrieval network which services FTD and other government installations. Some of the documents of interest will be on microfiche and will have identifying numbers. After the analyst terminates his search at the teletype, he can either order hard copies of the documents, order microfiche, or actually go over to the microfiche storage center and obtain microfiche which can be read on an optical viewer. The existing teletype terminals are hard wired to an IBM 360 computer in the central computer area via a DEC PDP 11/45 concentrator.

The Foreign Technology Division is currently installing a two-way coaxial transmission cable within the building to service all information systems and remote peripherals connected to the IBM 360 computer (a second coaxial cable will service the Univac computer facilities). After the coaxial transmission cable is installed, all remotely located equipment, such as the teletype terminals for the interactive Library Information System, will utilize the cable. Figure 2-2 shows one possible configuration where all terminals are time division multiplexed via 48 Kbps receive/transmit modems over the cable.

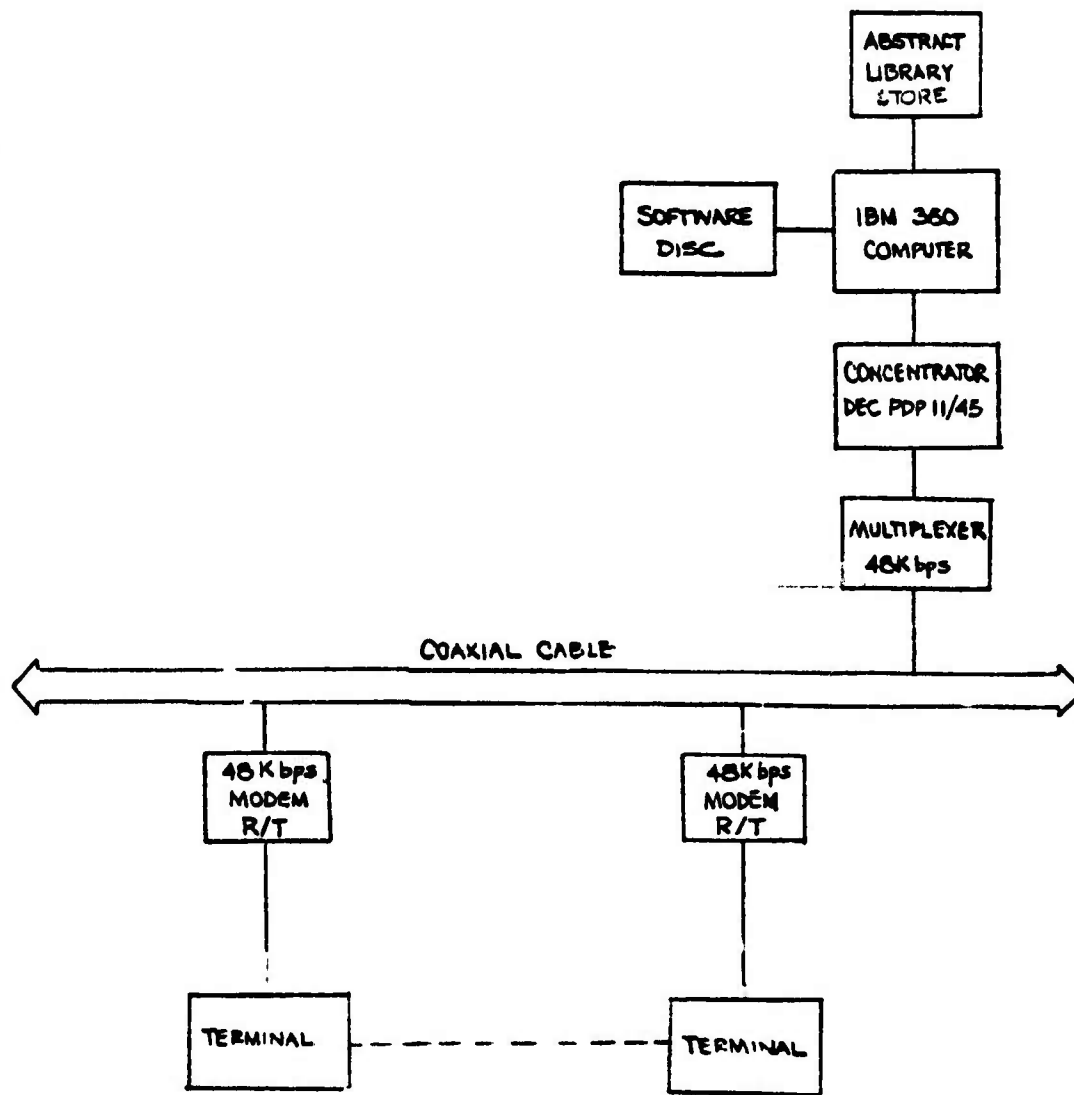

INTERACTIVE ABSTRACT LIBRARY INFORMATION SYSTEM

FIGURE 2-2

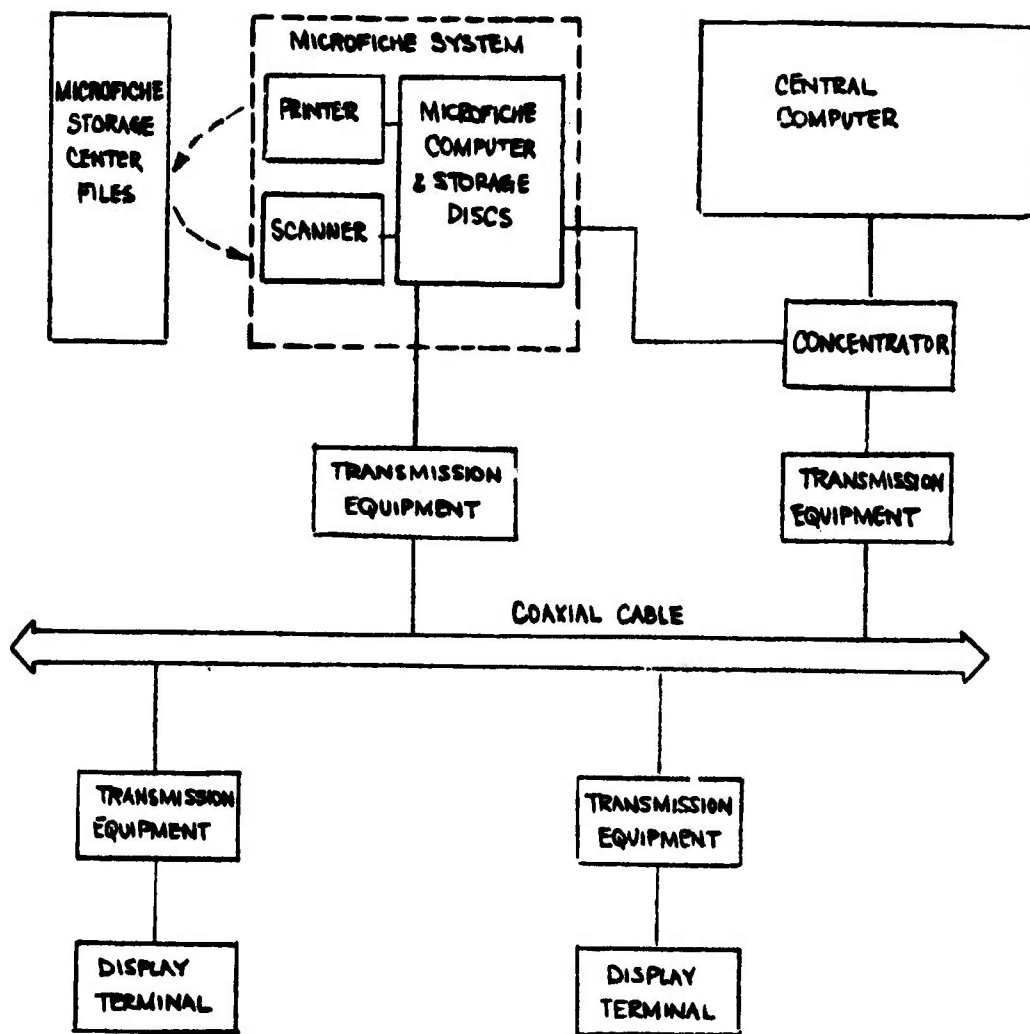

FUNDAMENTAL BLOCK DIAGRAM OF MICROFICHE
SCANNER AND REMOTE DISPLAY SYSTEM

FIGURE 2-3

The next logical step in upgrading the information retrieval facilities would be the installation of an automated Microfiche Scanner and Remote Display System. This will provide direct access of the FTD microfiche data base by analysts using remote display terminals. Definition and evaluation of the Microfiche Scanner and Remote Display System is the primary objective of this study.

2.2 MICROFICHE SCANNER AND REMOTE DISPLAY SYSTEM

A preliminary block diagram of the Microfiche Scanner and Remote Display System illustrating the major system components is shown in Figure 2-3. Major units include the microfiche archival storage center, scanner, central computer for control and storage, transmission channel, concentrator, and remote user terminals consisting of a display unit with keyboard. Many alternative configurations are possible, particularly in configuring the transmission paths and interface with the concentrator and other information systems.

During operation, the system is activated by keyboard requests from analyst users at remote locations within the FTD building complex. Microfiche document numbers, typed on the display keyboard, are transmitted to the microfiche archival storage center and recorded on a high speed printer. An operator at the center locates the requested document, manually feeds the microfiche into a scanner and types an identification code into the system. The microfiche pages are then automatically scanned, processed by the control computer, and placed in primary storage. The first page of the requested microfiche is then automatically routed via the transmission channel and displayed at the analyst's display terminal. Each page of the document can then be viewed by the analyst as desired. The system will be capable of handling a number of users simultaneously.

The purpose of this simplified system description is only to introduce the major system components and the operational concept so that the system requirements and basic operation are understood. A detailed description of the recommended system is given in Section 4.0.

2.3 SYSTEM REQUIREMENTS

The general requirements in this section form the basis for the Microfiche Retrieval and Display System at the offset of the study.

2.3.1 COMPATIBILITY WITH EXISTING FTD FACILITIES

- a. The system will utilize the existing FTD microfiche data base.
- b. A dedicated microfiche storage computer will be provided because of the current load on existing facilities.
- c. The Microfiche System will be controlled by the existing DEC PDP 11/45 concentrator.

2.3.2 COMPATIBILITY WITH PLANNED FTD FACILITIES

- a. The Microfiche System will utilize the FTD coaxial transmission cable.
- b. The system will consist of a network of at least 40 interactive display terminals located within the FTD building complex with a growth potential of up to 100 terminals. Common display terminals will be used for all information systems.
- c. The system will optimize utilization of the transmission link. This will be achieved by some form of dynamic transmission channel allocation so that no more than ten wide bandwidth channels are needed for the Microfiche System.

2.3.3 GENERAL SYSTEM REQUIREMENTS

- a. The Microfiche System should react to the initial request within 30 seconds. During this period, a microfiche will be loaded, transferred to primary storage, and finally, the first page of the requested microfiche will be displayed at the requestor's remote terminal.

- b. The primary storage buffer will provide sufficient storage to interact with a minimum of 40 active users. Each active user will be able to maintain one microfiche (assuming an average document of 20 pages) in the primary storage area until he disconnects.
- c. Human factors will be given primary consideration in defining man/machine interfaces.
- d. Available hardware will be given prime consideration during specification of the system.
- e. Microfiche will be manually fed between the storage center and the scanner.
- f. No special operator skills shall be required to operate the system.
- g. The reliability and maintainability of the system will be consistent with a very high utilization rate.
- h. The operating environment will be normal laboratory or office.

2.3.4 MICROFICHE DATA BASE

The Foreign Technology Division presently maintains over 100,000 microfiche in the existing storage center. It's reasonable to expect the total to expand beyond 250,000 as more incoming documents are converted to microfiche.

Only one standard size microfiche, 105 mm x 148 mm (approximately 4 x 6 inches) in size with 98 frames (7 rows x 14 columns) reduced by 24X, will be stored. Figure 2-4 illustrates this International Microfiche Standard showing dimensions and tolerances. The system will recognize only single pages, 10 mm wide x 12 mm high. All data and text will be orientated in the same direction as on a standard 8-1/2" x 11" typed document (that is, no pages will be rotated 90° in orientation on the microfiches). Other standard sizes, such as the 60 frame (5 rows x 12 columns), currently intermingled in the FTD microfiche files, will not be processed by the system (however, a scanner which handles both sizes could be configured).

Typical documents within the microfiche data base consist of type-written pages, reports, government forms, catalog sheets, reprints with two or three columns of text, graphics, and half-tone photographs.

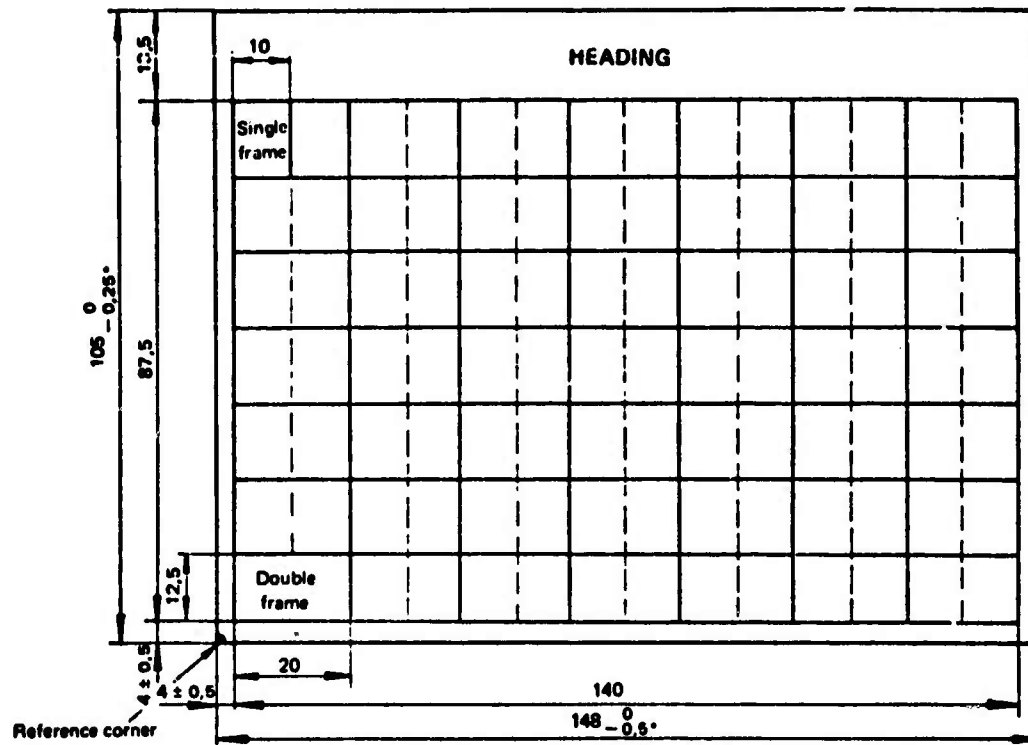

• Manufacturing tolerances for raw film.

Transparent A6 size microfiche of uniform division;
image arrangement No. 2 (98-frames).

Dimensions in millimetres

INTERNATIONAL MICROFICHE STANDARD

FIGURE 2-4

Quality levels for the microfiche contained within the data base vary widely. Examples of the quality range is illustrated in Figure 2-5, 2-6, and 2-7 which represent excellent, fair, and poor microfiche pages photographed on an optical viewer. Observe that Figure 2-7, which consists of two pages from a monograph, cannot be read on an optical viewer. Fortunately, only a small portion of the data base is of poor quality.

The quality of this microfiche data base will be continually improved. FTD has recently acquired a new microfiche camera so that all additions to the data base can now be maintained within appropriate quality limits (if the original document is of satisfactory quality).

2.3.5 MICROFICHE STORAGE CENTER

Although definition of the microfiche storage center is not within the scope of the study, the essential elements will be discussed in order to clarify the operation and requirements of the system. Figure 2-8 illustrates the organization and structure of a viable microfiche storage center (although not necessarily the best arrangement for FTD). The essential functional units consist of the microfiche storage files, a high speed printer to receive requests from remote stations, and one or more scanners to convert microfiche images into a digital data stream. The scanners, which are part of the system being defined, interface with the control computer in an adjacent room.

REFERENCES

1. FTD CIRCOL Search No. 065385.
2. Defense Documentation Center, Search Control 009590.
3. Basil'yev, V. G., Glushkov, R. N., et al. "'TsAGI' System Flutter Indicator." Patent No. 200843, TRD-HT-23-1375-68, 1965.
4. Basis, A. Ts., Lazarev, L. I., Lebedev, A. G., and Strelkov, K. S. "Flutter Indicator," 1967.
5. "Model of an Aircraft in the Wind Tunnel Prior to Testing for Flutter," PRIRODA No. 5, 1970.
6. "Soviet Tu-144 SST Wing, Fuselage Section Tested," Aviation Week, April 19, 1971.
7. Bykov, V. S. and Komshinshiy, B. A. "A Device for Measuring Low Damping Moments when Testing Models in Wind Tunnels," USSR Patent No. 128179, FTD-HT-23-1854-72.
8. Matneyev, A. P. "A Device for Determining the Rotating Derivatives of Models with Respect to the Transverse Axis," USSR Patent No. 160884, FTD-HT-23-1620-74, February 26, 1964.
9. Belotserkoukiy, S. M., Bedenho, A. A. and Odnoval, L.A. "A Device for Determining the Rotational Derivatives of Models Studied in Aerodynamic Installations," USSR Patent No. 190634, FTD-HT-23-1619-74, December 29, 1966.
10. Bychkov, N. M., Dubrovskiy, B. L., and Kovalenko, V. M. "Experimental Investigation of the Magnus Effect on a Greatly Elongated Finned Rotating Body at $M = 4$," FTD-HT-23-32-74, 1972.

EXCELLENT QUALITY MICROFICHE SAMPLE
FROM FTD DATA BASE

FIGURE 2-5

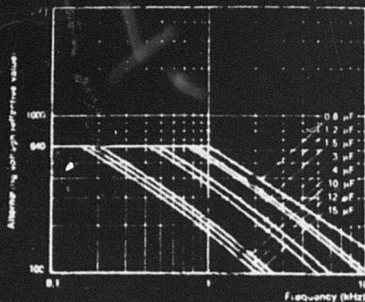

Fig. 10 Permissible capacitor AC voltage shown against frequency for capacitor rated voltage $U_{Neff} = 640$ V

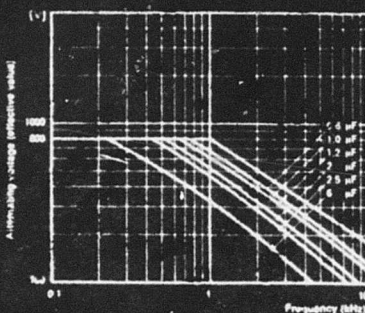

Fig. 11 Permissible capacitor AC voltage shown against frequency for capacitor rated voltage $U_{Neff} = 800$ V

2.5.5 Calculation of capacitor current

The following formula is valid for linear change in charge according to Fig. 3a:

$$J_{eff} = \frac{C (U_1 + U_2)}{T} \cdot \sqrt{\frac{T}{t_1} + \frac{T}{t_2}}$$

The following formula is valid for sinusoidal and combined change in charge according to Fig. 3b or 3c:

$$J_{eff} = \frac{\pi}{2\sqrt{2}} \cdot \frac{C (U_1 + U_2)}{T} \cdot \sqrt{\frac{T}{t_1} + \frac{T}{t_2}}$$

C = Capacity (F)
 J_{eff} = capacitor current (effective value) (Amps)
 T = period time (sec)
 t = change of charge time (see Fig. 3) (sec)
 U₁ = positive voltage amplitude (V)
 U₂ = negative voltage amplitude (V)

8

In the case of trapezoidal voltage with a steep rise slope and high operating frequency the resulting current can reach a very high value.

The effective current value quoted in the specification sheet must not be exceeded at the upper temperature limit (85 °C).

2.5.6 Calculation of capacitor power

The following formula is valid:

$$Q = \left(\frac{U_1 + U_2}{2} \right)^2 \cdot \frac{2\pi}{T} \cdot C \cdot k$$

C = Capacity (F)
 Q = Capacitor power (Watt)
 T = period time (sec)
 t = change in charge (see Fig. 3) (sec)
 U₁ = positive voltage amplitude (V)
 U₂ = negative voltage amplitude (V)
 k = $\left(\frac{t}{T} \right)$

The diagram (Fig. 12) shows the factor k against $\frac{t}{T}$ for linear and sinusoidal change of charge. In the case of combined change of charge the curve for sinusoidal change of charge should be used.

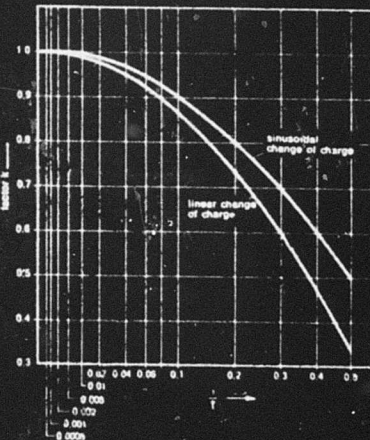

Fig. 12 Factor k for power calculation

With trapezoidal voltage having a steep rise slope the power can reach a very high value. The power limiting values quoted in the specification sheet at a housing temperature of 85 °C must not be exceeded.

2.5.7 Permissible temperatures

The rated values for voltage, current and power (see specification sheet for MPK capacitors) relate to a housing temperature of +85 °C. For lower housing temperatures higher values are permissible (factors > 1 see Figs. 13 to 15).

In case only the ambient temperature is known the housing temperature can be taken from Fig. 16.

FAIR QUALITY MICROFICHE SAMPLE
 FROM FTD DATA BASE

FIGURE 2-6

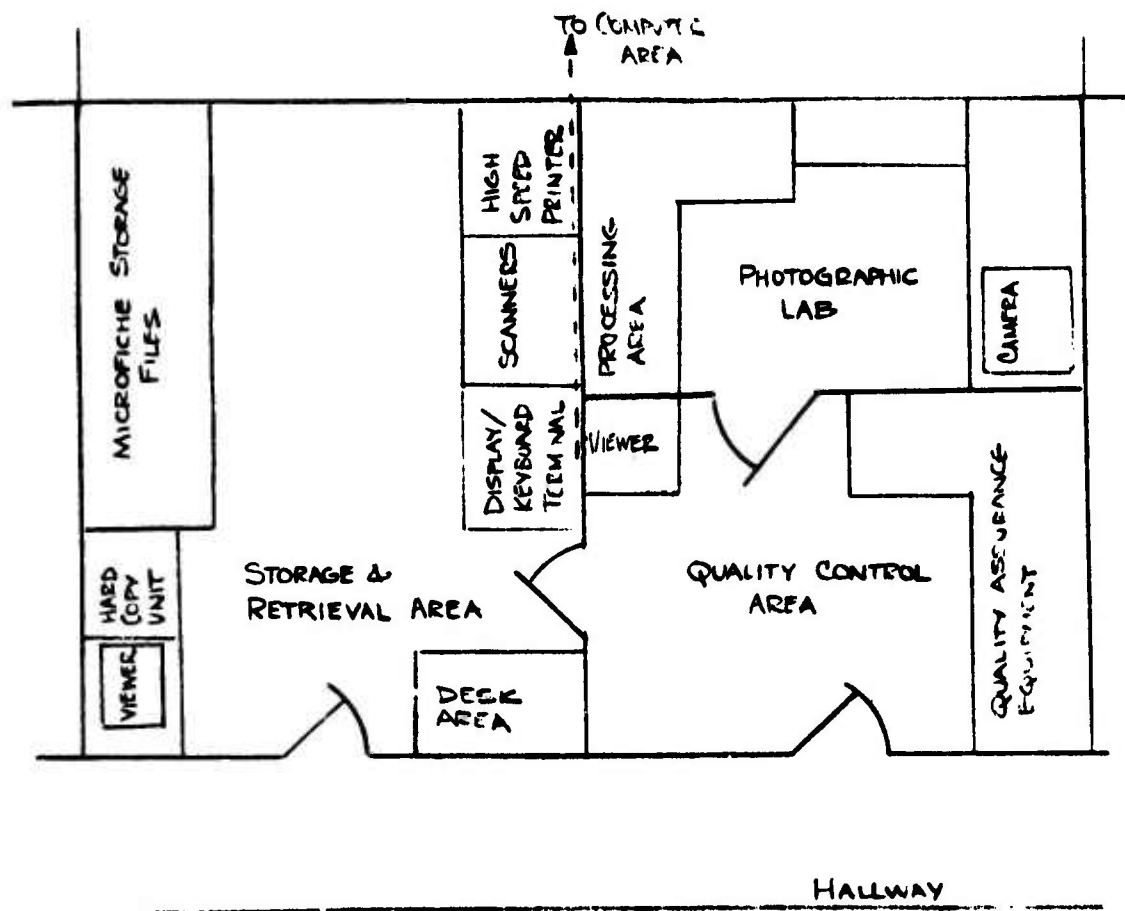

MICROFICHE STORAGE CENTER

FIGURE 2-8

In addition, the storage center may contain interactive display terminals for file searching and document display; a microfiche processing and quality control lab; equipment to produce hard copies of documents; and perhaps in the future, automated equipment to retrieve microfiche and feed the scanner.

2.3.6 MICROFICHE SCANNER

The microfiche scanner is the input element for the automated portion of the Microfiche Scanner and Display System. Its function is to scan the microfiche record and transform the pages on microfiche to a digital signal. This signal will then be stored in the primary buffer until transfer to the remote display terminal is requested. (The first image in the microfiche is automatically transferred to the user).

A number of alternative scanner configurations are considered for this application. Alternative technologies include television cameras, flying spot scanners, image dissectors, laser scanners, and solid state scanners. In general, the scanner must satisfy the following requirements:

- a. The scanner must accommodate a manually loaded microfiche and index it to the proper orientation for scanning.
- b. The scanner must scan and digitize each page of the microfiche in sequence.
- c. It must provide operator interaction via an alphanumeric keyboard so that appropriate identification codes can be input.

- d. The scanner output must be a digital binary form of signal representing opaque and transparent areas on the page of interest (no gray tones).

2.3.7 COMPUTER AND MASS STORAGE

The microfiche computer provides for the overall control of the Microfiche Scanner and Remote Display Systems and contains the mass storage required to hold digitized microfiche page images for the active users. The general microfiche computer requirements follow:

- a. A dedicated computer system is needed because of the load on existing computer facilities. The DEC PDP 11 family of computers will be used, since they are being satisfactorily employed and are well understood by the technical personnel at FTD.
- b. The computer will interface with the coaxial transmission system via the existing IBM 360 concentrator (a DEC PDP 11/45 computer which simulates an IBM Model 2703 communications processor).

2.3.8 TRANSMISSION LINK

The transmission system to be used to link the remote terminals to the Microfiche Computer is well defined. A two-way coaxial cable network will be installed at FTD by Interactive System, Inc. The cable can be used to accommodate the Microfiche Scanning and Remote Display System transmission requirements in addition to other communication networks.

The basic distribution system, discussed in detail in Section 4.5.1 provides up to 100 channel capability for two-way operation. Branching from the main cable is easily accomplished using standard modems, couplers, and amplifiers.

The following general requirements relate to the transmission link:

- a. The system must be configured to make the best use of the bandwidth (300 MHz) of the transmission lines. This will include the incorporation of time division multiplexing for communication with the concentrator (for interactive dialogue) and dynamic allocation of shared high speed transmission channels to transmit imagery from the Microfiche Computer.
- b. The transmission channel which is confined to the FTD building complex will be used to eliminate the hard wiring of system components. The maximum cable length is less than 1,500 feet long.
- c. Encryption of the data transmitted for security purposes is not required because the entire cable network is interior to a secured area.

2.3.9 REMOTE DISPLAY TERMINAL

Each remote display terminal consists of a cathode ray tube display monitor to view microfiche documents; a send-receive keyboard to communicate with the control computer; and, if necessary, a full page buffer to refresh the CRT (if a non-storage display tube is specified).

The remote user communicates with the control computer via the keyboard. He can utilize the on-line keyboard to:

- a. interactively search the microfiche data base, obtain textual abstracts, and once locating desired documents, request microfiche film by identification numbers.
- b. initiate a microfiche document request via the high speed printer in the microfiche control center.
- c. view other pages of the microfiche currently in primary storage by keying appropriate commands.
- d. request additional documents or terminate the session.

The data called up by the user is displayed on the screen at his work station. Data is retained on the display for as long as the user wishes and can be erased and replaced by other data at the user's command.

The basic requirements for such a remote display station include the following:

- a. The format of the display device will be of sufficient size to display an 8-1/2" x 11" original document at least full size.
- b. Human factors will be considered in specifying the size, configuration, resolution and brightness of the display.
- c. One page of data will be displayed (on command) on the screen at the user's work station.
- d. The user will have the ability to call up pages in any sequence within several seconds from the primary buffer.

- e. The display will be designed for good legibility when employed under normal ambient lighting conditions.
- f. The resolution should be adequate to distinguish 1/16" high characters on the original with 98% probability of recognition at ambient conditions.
- g. If a non-storage type CRT is used, the repetition rate will be high enough to prevent flicker. A refresh buffer will be supplied at each terminal with sufficient storage to hold one frame.
- h. The keyboard terminal will be a send-receive configuration capable of transmitting ASCII code.
- i. The terminal must have a built-in character generator to display and transmit alphanumeric messages.
- j. A hard copy capability is not required (however it is desirable for flexibility and growth).

2.3.10 DATA COMPRESSION

Data compression may be utilized in the system, if necessary, to make the most efficient use of the mass storage and the transmission channel. The cost and performance trade-offs of implementing data compression must be considered.

2.4 SYSTEM PARAMETERS

The objective of this section is to establish system operating parameters for use in defining the Microfiche Scanner and Remote Display System. Selection of the system parameters is highly dependent on the system requirements,

equipment constraints, microfiche quality, legibility expectations, and a host of other factors. The parameters established at this stage are preliminary. Once candidate equipment selections are made, parameters can be optimized for a particular configuration (as in Section 4 for the Recommended Microfiche System).

2.4.1 LEGIBILITY CRITERIA

Of all of the variables that must be tied down in establishing system parameters, output quality is perhaps the most involved - primarily because it is difficult to quantify as many subjective factors influence the viewer. Many studies have been conducted to assess the legibility and overall quality of images transmitted using high resolution TV and other communication systems. Results from this technical literature can be used to establish resolution requirements.

At the input end, the fundamental parameters related to the resolution capabilities of the system are the size of the scanning spot, scan density (scan lines per inch), scan line overlap, spot shape, quality of the input microfiche and other factors.

In examining the resolution determines for high legibility, an input microfiche size of 0.354" x 0.458" representing a 24X reduction of a 8-1/2" x 11" document is considered.

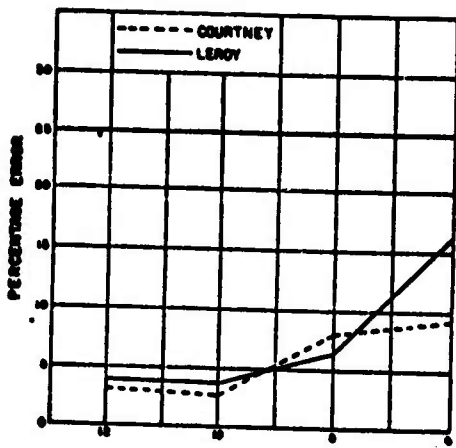

NUMBER OF SCAN LINES PER SYMBOL HEIGHT
 Relationship Between Identification Accuracy and Number of TV Scan Lines for Two Symbol Sets

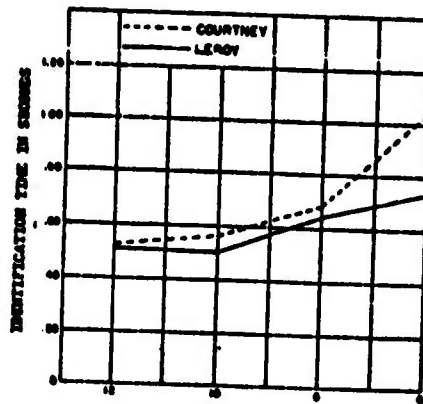

NUMBER OF SCAN LINES PER SYMBOL HEIGHT
 Relationship Between Identification Speed and Number of TV Scan Lines for Two Symbol Sets

LEGIBILITY RESEARCH

FIGURE 2-9

For legible individual characters a review of the literature¹ indicates that about 10 scan lines/character height are required to minimize character recognition errors and to reduce identification time. Figure 2-9, taken from Dr. D.A. Shurtleff's paper entitled, Legibility Research, illustrates these relationships. Ten scan lines per symbol height appears to be the point at which the percentage of recognition errors and identification time are optimally reduced for specific symbol sets. For word identification in textual material, about half of the scan lines would be required². Use of fewer scan lines than suggested in the literature is still acceptable; however, the probability of recognition would be further degraded.

Initially assume that the minimum character height commonly encountered for text type materials, normally - books, letters, forms - is close to 1/16 inch (the lower case e is used as a reference). This equates to a scan density of 160 scan lines/inch (assuming no scan line overlap). Therefore, approximately 1760 scan lines per document height are required (for a standard 11-inch high document). Since about 1500 scan lines per display height represents the limit for practical CRT display design, the requirement of 160 scan lines/inch is too demanding. Therefore, either a lower scan line density must be employed - with an accompanying reduction in the probability of symbol recognition - or a magnification of information on the display (zooming) is needed, providing an effective 1500 line resolution over a quarter of the page size.

¹ Dr. D.A. Shurtleff, "Legibility Research", Proceeding of the S.I.D.
Vol. 15-2 Second Quarter 1974
² D.M. Costigan, "FAX", Chilton, pp.142, 1971

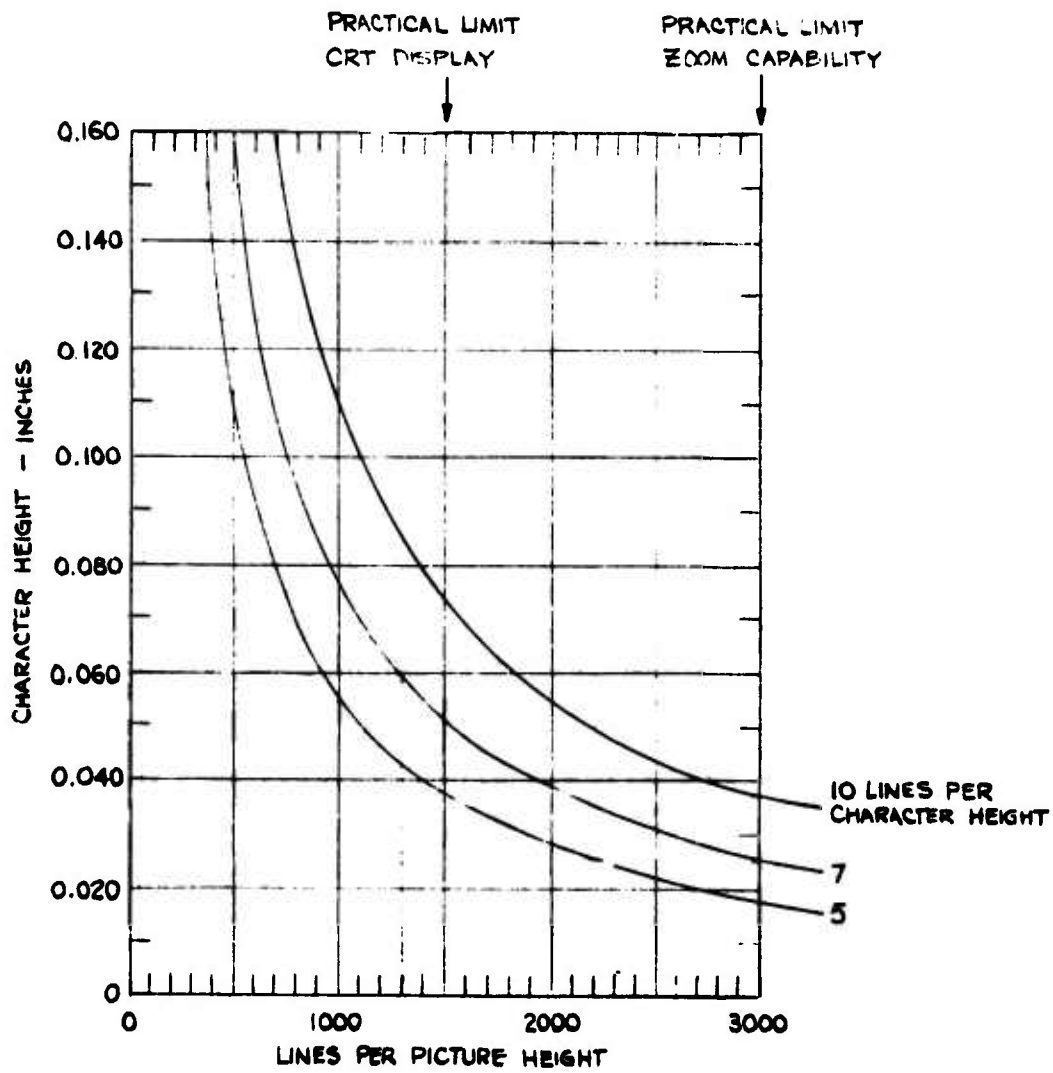

SCAN LINES VERSUS CHARACTER HEIGHT

FIGURE 2-10

Figure 2-10 illustrates the scan line density per picture height versus character height for several legibility criteria. It can be seen that for a criteria of seven scan lines per character height only 1,300 lines per picture height are required for the 1/16 inch character. The probability of recognizing 1/16" high letters is lower (than when 10 scan lines/character are used) but still adequate; in fact, it is still excellent for word recognition.

This compromise solution of being satisfied with seven scan lines per character height is not satisfactory for the FTD data base which contains lower case letters and symbols as small as 0.030 inch high. A 1500 line per picture height display could only handle a 0.050 inch high letter using the seven line per character height criterion. Hence, a zoom capability which allows a 2:1 magnification of the image size on the display is needed to read the smallest character. With 2:1 zoom, a 1500 line per picture height display handles one-quarter of a page of text with an effective 3000 line per picture height resolution. A 0.025 inch high symbol, therefore, can be effectively scanned using 7 scan lines per character height.

An alternate solution is to find, or develop, a CRT that operates at a higher resolution than 1500 scan lines. This is not practical as there are many technical reasons why high resolution displays operate in the 1000 to 1500 scan line per picture height range. Much of the circuitry becomes more involved and costly as the bandwidth requirements increase. In addition, as the spot size is reduced, it is increasingly difficult to achieve the brightness levels needed for good viewing.

2.4.2 NUMBER OF PIXELS PER DOCUMENT PAGE

A parameter which must be carefully optimized is the microfiche page element density or number of pixels required per document page (obtained by multiplying the number of elements per line by the number of scan lines per page height). This parameter must be as high as possible to maximize the resolution of the system. On the other hand, it must be minimized because increasing the data density has a detrimental impact on system cost and performance. As the data density increases, the system scan time, transmission time and response time all lengthen. The primary storage size, computer core size and system complexity also must increase as the data density per page goes up.

This conflict in establishing the optimum value for the page pixel density is resolved by closely examining the display terminal resolution limit, legibility criteria, and microfiche resolution currently achieved on a good optical viewer. Table 2-1 summarizes the rationale for the number of pixels per document page selected.

TABLE 2-1

RATIONALE - NUMBER OF PIXELS PER DOCUMENT PAGE

Display Terminal Limit	1500 Elements/Display Height 1160 Elements Per line
Zoom Assist	Effective 3000 Line Resolution
Microfiche Resolution (Good Quality Optical Viewer)	3 lp/mm Referred to Original 1676 Line Vertical Resolution 1295 Elements Per Line
Legibility Criteria	Minimum of 7 Scan Lines/Character Height 1250 Scan Lines for 1/16" High Character 2500 Scan Lines for 1/32" High Character

Perhaps the most important consideration is the display terminal resolution limit. When using the best available display about 1500 elements per display height can be resolved. This implies a resolution of 1160 elements across a scan line (assuming an 8-1/2" x 11" aspect ratio), or 1.74×10^6 elements per microfiche page. When the 2:1 zoom capability is adapted, the effective resolution required at the scanner is 3000 lines by 2320 elements per line. This corresponds to 6.96×10^6 elements per microfiche page. There is no advantage in using more elements, since the display cannot resolve them. Fewer elements result in reduced legibility.

The resolution of microfiche on a good quality optical viewer is about 3 lp/mm referred to the original. This corresponds to 1676 line vertical resolution with 1295 elements across the line. This is slightly better than the terminal resolution limit. Consequently, the resolution obtained using 1500 elements per display height will be slightly poorer than on an optical viewer. Inasmuch as zoom can be employed, the capability exists of obtaining display resolution far in excess of the optical viewer.

2.4.3 ELEMENTS PER PICTURE VERSUS TRANSMISSION TIME

Once the number of elements per picture is determined, the storage requirements and transmission time can be identified. Table 2-2 shows how these parameters are affected as the lines per picture height and elements per line vary. For the optimum case selected all 6.96×10^6 elements per page must be stored. Only one-quarter of these elements, 1.74×10^6 bits, need to be transmitted for either the normal resolution or zoom operational mode. This would take 5.8 seconds to transmit via a 300,000 bps modem.

TABLE 2-2

ELEMENTS PER PICTURE VERSUS TRANSMISSION TIME

LINES/PICTURE HEIGHT	ELEMENTS/LINE	ELEMENTS/PICTURE	STORED ELEMENTS	TRANSMITTED ELEMENTS	TRANSMISSION TIME
1400	1080	1.51×10^6	1.51×10^6	1.51×10^6	5.03 SEC
1500	1160	1.74×10^6	1.74×10^6	1.74×10^6	5.79
1600	1240	1.98×10^6	1.98×10^6	1.98×10^6	6.6
2000	1550	3.10×10^6	3.10×10^6	3.10×10^6	10.33
2500	1930	4.825×10^6	* 4.825×10^6	1.21×10^6	4.022
2800	2160	6.06×10^6	* 6.06×10^6	1.51×10^6	5.03 SEC
3000	2320	6.96×10^6	* 6.95×10^6	1.74×10^6	5.79
3200	2480	7.91×10^6	* 7.91×10^6	1.98×10^6	6.6

ASPECT RATIO $8 \frac{1}{2} \times 11$

* CAN PROVIDE 2:1 ZOOM

2.4.4 PARAMETRIC ANALYSIS

In establishing the system parameters, it was necessary to conduct the analysis parametrically, at least until most of the system components were defined. This allowed parameters to be quickly changed and system performance rapidly determined for alternative configurations.

An illustration of one tool used in the parametric analysis is shown in Figure 2-11. Consider, for example, the case of 3000 scan lines per page. The lower left hand graph, which is set up for an 8-1/2 x 11 aspect ratio, gives 7×10^6 elements per page. The upper graph determines the average number of users sharing the computer's mass storage (assuming a 20 page average microfiche). Forty users can be accommodated for the case of no data compression and a storage size of eight 44M word discs (16 bits per word). Once the scanner bandwidth is selected, 2.0 Mbps in this case, the time required to scan either one microfiche page or an entire microfiche (containing an average of 20 pages) can be determined with the graph on the right. An average document takes approximately 1-1/4 minutes to scan.

A number of different combinations of parameters were assessed during the analysis for different equipment alternatives. In this manner, the performance of various equipment combinations were optimized. Table 2-3 illustrates one of the sets of system parameter lists derived (which is for the system recommended in Section 4).

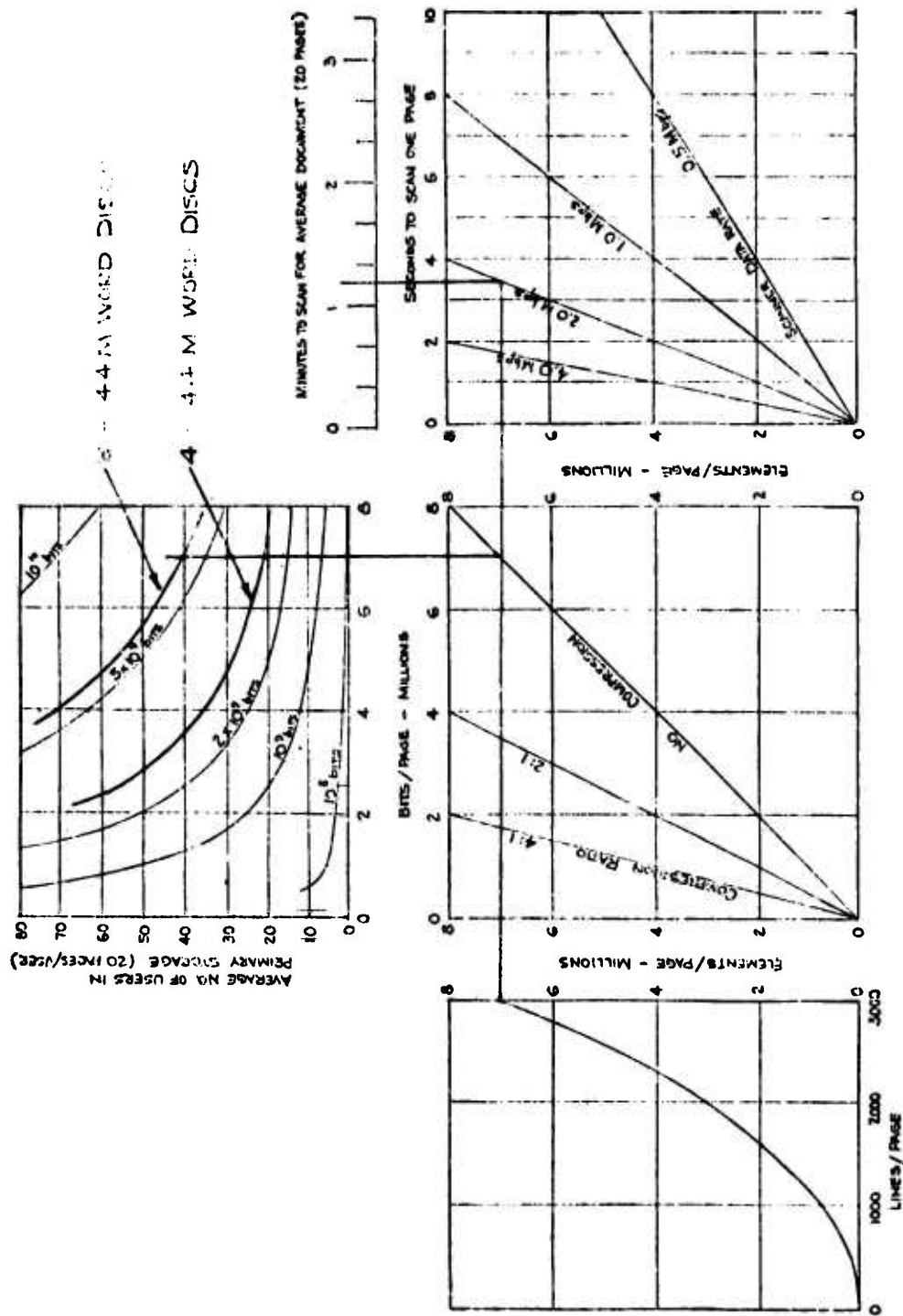

MICROFICHE SCANNER PARAMETRIC ANALYSIS

FIGURE 2-11

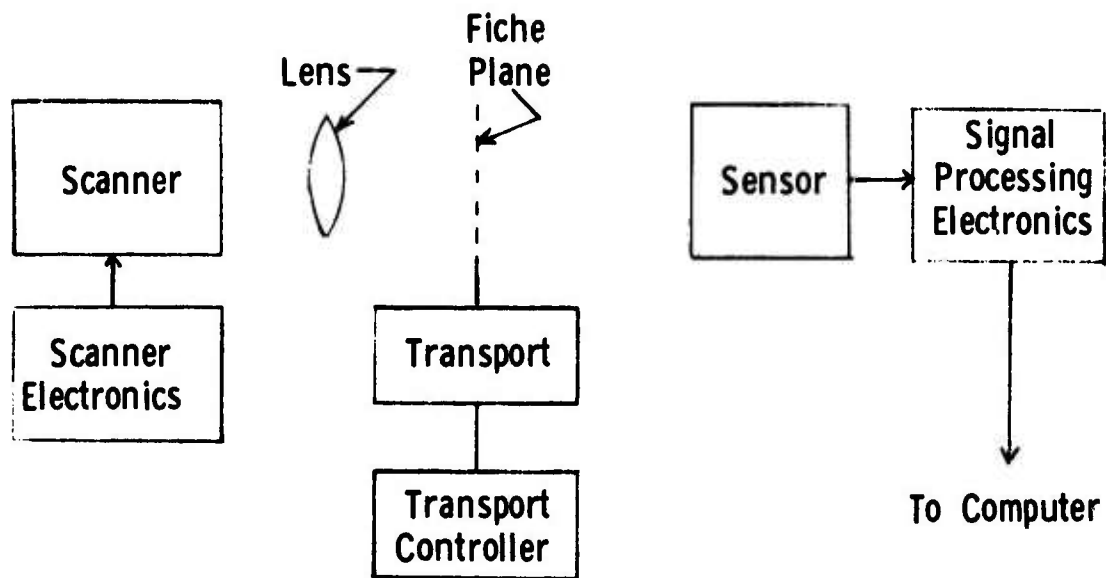

SCANNER SYSTEM - GENERAL BLOCK DIAGRAM

FIGURE 3-1

SECTION III

CANDIDATE EQUIPMENT AND SYSTEM CONFIGURATION SELECTION

3.0 GENERAL

In performing the definition study for the Microfiche Scanner and Remote Display System, various types of available equipment having potential for use in the system were investigated. The general requirements established in the previous section were used as a basis for identifying and culling promising equipment.

The selection process of the major system elements is discussed. Where many equipment alternatives exist, the justification for selection of a particular type or model is established through trade-off analyses and comparisons. Equipment selection is based on comparative performance, cost, reliability, human factors and availability; and experimental tests in the case of the display terminal.

The emphasis on equipment selection has been directed primarily towards the microfiche scanner and remote display terminal - two critical system components involving direct man/machine interaction.

For other functions, such as the computer and transmission link, equipment type and vendors have essentially been defined by the government in their requirements. The selection process, therefore, relates more to defining peripherals, storage size and special interfaces. This is treated in detail for the recommended system in Section 4. Alternative system configurations, however, are identified in this section and an approach is recommended.

3.1 MICROFICHE SCANNER

The scanning portion of the overall microfiche scanner-remote display system consists, in general, of the following:

- Scanner
- Scanner electronics
- Lens (or optical system)
- Fiche transport
- Transport controller
- Sensor
- Signal processing electronics

Figure 3-1 shows such a generalized system in block diagram form.

3.1.1 DESCRIPTION OF CANDIDATE SCANNING SYSTEMS

At the beginning of this program, a number of scanning systems were thought to have the potential of meeting the requirements associated with a microfiche scanner. All of these scanning systems had been used for similar applications in the past and none appeared to be dependent upon "state-of-the-art" technology. Specifically, these systems were:

1. Image Dissector
2. Flying Spot (CRT) Scanner
3. Vidicon Camera
4. Laser Scanner
5. Solid State Scanner

A brief description of each of these scanners is presented below. Other sections of this report will be devoted to a detailed description of the analysis which led to the selection of the particular scanning system for this application.

3.1.1.1 Image Dissector. Figure 3-2A shows a sketch of an image dissector scanning system. In such a system, the page to be scanned is illuminated from the back. This page is then imaged by a lens onto the photocathode of the image dissector. The resulting photoelectron "image" of the page is electromagnetically scanned across an aperture. At any instant in time, therefore, the number of electrons passing through the aperture (the signal) is a function of the illumination at a corresponding location on the photocathode. These electrons enter an electron multiplier. The amplified signal is subsequently fed into the signal processing electronics and onto the computer.

3.1.1.2 Flying Spot Scanner. Figure 3-2B shows a sketch of a flying spot (CRT) scanning system. As shown in this sketch, a spot of light is generated on the face of the CRT. This spot, in turn, is demagnified and focussed onto the fiche. As this spot scans the page on the fiche, the transmitted light is focussed onto the face of the photomultiplier (PMT). The resulting photoelectrons are amplified by the electron multiplier portion of the PMT. The output current from the PMT is fed into the signal processing electronics and onto the computer.

3.1.1.3 Vidicon Camera. A vidicon camera consists of a photoconductive target and a low energy electron (read) beam. The page to be scanned is illuminated from the back and its image is focussed onto the uniformly charged photoconductive target. The resulting increase in the conductivity of the target elements causes the surface potential of these elements to shift to the potential of the backing plate. A potential pattern corresponding to the imaged

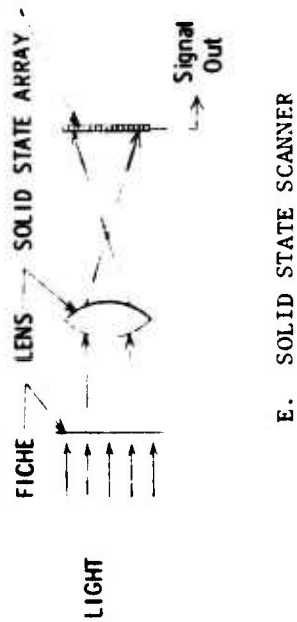
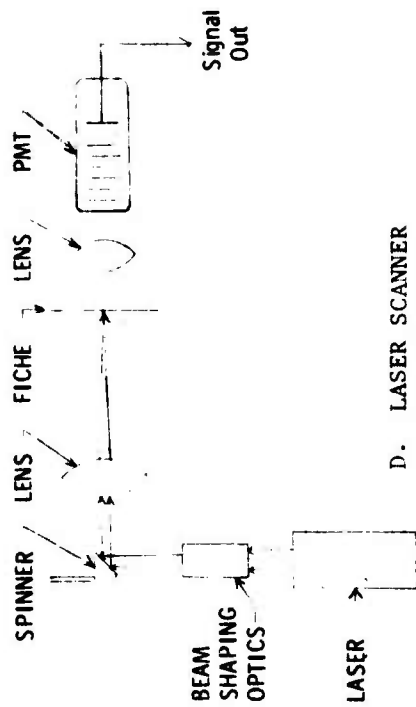
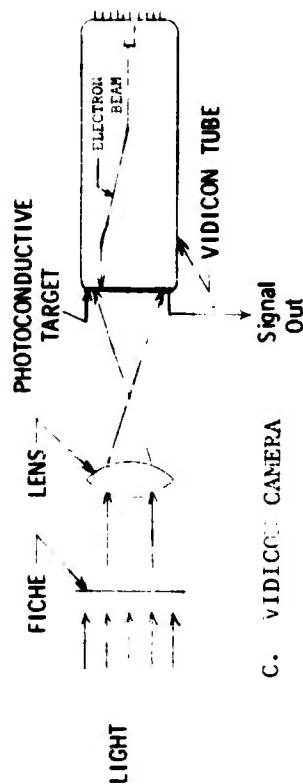
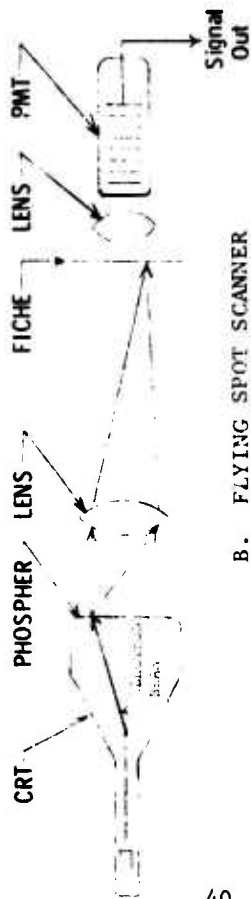
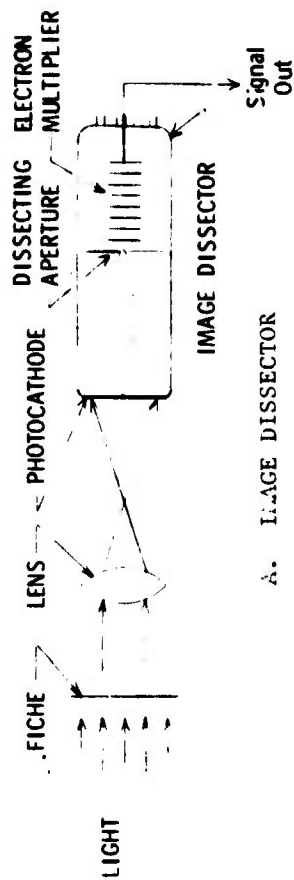

SCHEMATIC DIAGRAMS OF CANDIDATE SCANNING SYSTEMS

FIGURE 3-2

page is thus established on the target. To generate an output signal, the target is scanned by the low energy electron beam. This beam replaces the charge on the surface of the target and shifts the target elements back to their original potential. This charge replacement process results in a capacitive current through the target which is proportional to the amount of replacement charge deposited on a particular target element. As with the other scanners, this signal current is fed into the signal processing electronics and on to the computer. Figure 3-2C shows a sketch of the vidicon camera scanning system.

3.1.1.4 Laser Scanner. The laser scanner is very similar in operation to the flying spot scanner. However, in the case of this scanner, a laser is used to generate the scanning spot. The scanning spot is obtained by first passing the laser beam through a set of optics. The function of these optics is to generate a spot of light that is uniform in intensity. The beam is then directed onto a scanning spinner. The spinner deflects the beam through a given angle at a uniform angular velocity. The beam then passes through an objective lens and a field flattening lens. Thus, as the beam moves through a given angle, a focussed spot moves across the width of a page on the fiche. During each line scan interval, the fiche is moved in the direction of the page height a distance equal to the width of the scanning spot. In this way, the entire page can be scanned.

As with the flying spot scanner, the light transmitted through the fiche is focussed onto the face of a PMT (or photodiode) and the resulting signal fed into the signal processing electronics. Figure 3-2D shows schematically such a scanning system.

3.1.1.5 Solid State Scanner. "Solid State Scanners" is a broad category which includes both charge coupled arrays and photodiode arrays. These arrays can either be in the form of line or matrix arrays. In this application, only the line arrays have enough elements to become potential candidates.

While there are certain differences between a charge coupled array and a photodiode array, their operation and the operation of scanners utilizing these arrays can be described generally as follows:

The page to be scanned is illuminated from the back and the first line of that page is focussed onto the array. Electrons are accumulated within each element of the array in proportion to the intensity of the light focussed onto each element. These electron "bundles" are then transferred, one by one, out of the array and into the signal processing electronics. During the time required to transfer one line of charge bundles, the fiche is moved in the direction of the page height a distance equal to the line height. In this way, the entire page is scanned. Figure 3-2E shows schematically such a solid state scanner.

3.1.2 SELECTION OF MICROFICHE SCANNING SYSTEM

As a result of analyzing the requirements of the entire Microfiche Scanner and Remote Display System, a set of functional and technical specifications for the scanning portion of the system were established. These specifications are:

Functional Specifications

Scan, digitize and transmit data recorded on the microfiche

Interact with the computer:
Accept commands
Transmit data and status

Technical Specifications

Scan format	-	9.0mm x 11.6mm
# of pixels/line	-	2320
# of lines/page	-	3000
Output bit rate	-	2 Mbits/sec

In addition, the analysis presented in Appendix A showed that in order to realize virtually 100% accurate digitization of the output data, the scanner should have an output signal-to-noise ratio of at least 20:1 at the 130 lp/mm (2320/9.0mm) operating resolution.

With these functional and technical specifications being requirements of any scanning system selected, each of the candidate scanners discussed in Section 3.1.1 were evaluated with respect to their

- availability as an "off-the self" system
- theoretical performance
- estimated cost
- estimated reliability and maintainability

3.1.2.1 Availability. An extensive search was made to determine whether any of the candidate scanning systems were presently available as fully developed systems. In addition, inquiries were made to determine whether systems utilizing the same basic subsystems and concepts, but for other applications (e.g. image digitizers, laser recorder, etc.) could be adapted to this application in a cost-effective manner. The conclusions drawn from this effort were the following:

- a. No microfiche scanning system having all of the required functional and technical specifications is available as a fully developed system.

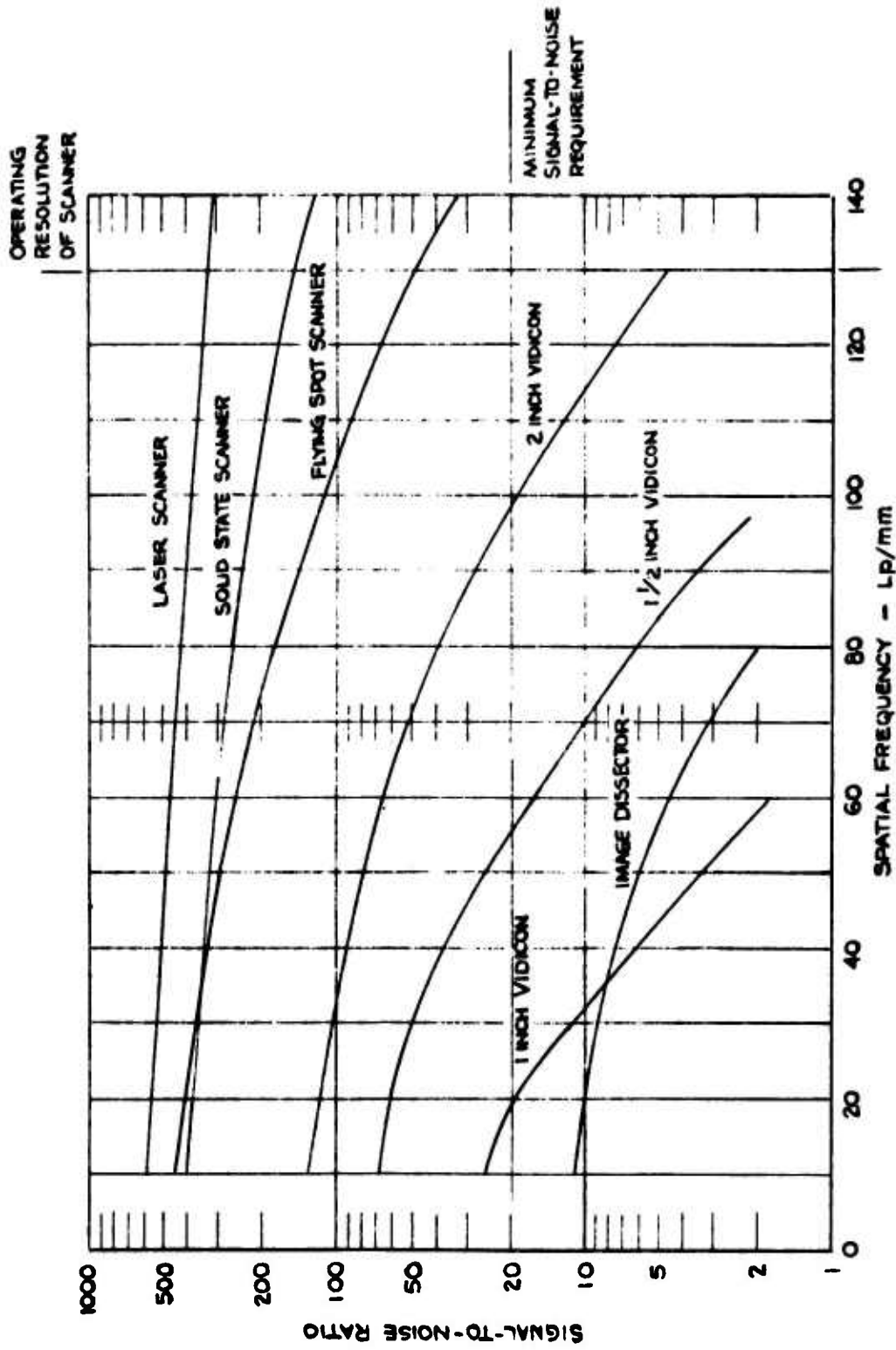

PERFORMING CURVES OF CANDIDATE SCANNING SYSTEMS

FIGURE 3-3

- b. Modifications of similar scanning systems presently being used for other applications can not be made in a cost-effective manner.
- c. All of the subsystems and components required to fabricate any of the candidate systems are commercially available and none depend upon "state-of-the-art" technology.

The subsequent performance, cost and reliability-maintainability evaluations of the candidate systems were, therefore, conducted on systems configured around commercially available subsystems and components.

3.1.2.2 Performance Analysis. Signal-to-noise models were developed for each of the candidate scanning systems. These models and their derivations are presented in Appendix A.

Using these models, or, where appropriate, variations of these models, the theoretical performance (signal-to-noise ratio vs spatial frequency) of each of the systems was determined. Figure 3-3 presents graphically the results of this analysis. The actual approach used in generating these curves and data on selected subsystems and components are presented in the following sections.

3.1.2.2.1 Performance Analysis of the Image Dissector Scanning System. The image dissector used in this analysis was an EMR* model #575. Data on this and other components used in determining the performance of the image dissector scanning system are presented in Table 3-1. Also presented in this table are values of other parameters used in the analysis.

*EMR Photoelectric, Princeton, New Jersey

TABLE 3-1

DATA USED IN GENERATING PERFORMANCE
CURVE FOR IMAGE DISSECTOR SCANNING SYSTEM

Fiche	4:1 contrast ratio
Lens	50 mm diameter #/f = 2 0.8 transmission coefficient
Illumination	2 watts/cm ² at back surface of fiche (2870°K)
Fiche-to-Dissector Linear Magnification	2.7X
*Aperture Size	18 micron diameter
*Dissector Response	τ_{ap} determined from formula A-13 τ_{is} adjusted to give 50% dissector response at 20 lp/mm at face of dissector (EMR spec. for #575 dissector)
Dissector Photocathode	S-20
Multiplier Gain	$1 \times 10^{+6}$
Secondary Emission Ratio of Multiplier Dynodes	2.2
Video Bandwidth	1 MHz
Load Impedance	$1 \times 10^{+5}$ ohms

*From EMR data

3.1.2.2.2 Performance Analysis of the Flying Spot Scanning System. The CRT package selected for use in this study was the Celco^{*}, five inch display system, Model D55-10-3. Pertinent data on this display system and values of other model parameters are presented in Table 3-2.

3.1.2.2.3 Performance Analysis of Vidicon Camera Scanning Systems. Three different vidicon camera scanning systems were analyzed; a system containing a 1" vidicon, one containing a 1-1/2" vidicon and one containing a 2" vidicon.

The vidicon tubes used in this analysis were Westinghouse^{*} slow scan vidicons

#WX-5111	(1")
#WX-5161	(1-1/2")
#WX-5156	(2")

Response values for these vidicons were obtained from information supplied by Westinghouse. In addition, data relating flat field signal current to exposure for a 3 seconds/frame scan time was supplied. This flat field signal current data eliminated the need to assign individual values to many of the parameters in the analytical model. That is, the flat field signal current is "I_o" as defined by equations A-57 and A-58 in Appendix A. Thus, the vidicon signal-to-noise equation A-84 reduces to:

$$\frac{S}{N} = \frac{2M_i \tau_L \tau_{\text{vidicon}} I_o}{\left[\frac{4kT\Delta f}{R_L} + 2eI_d \Delta f + 2eI_o \Delta f + 2en_c \Delta f (\eta_{\text{eff}} + 1) I_o \right]^{1/2}} \quad (3-1)$$

where, η_{eff} is the non-wavelength dependent equivalent of η_λ

*Constantine Engineering Laboratories Co., Mahwah, New Jersey

*Westinghouse Electric Corp., Electron Tube Div., Horseheads, N.Y.

TABLE 3-2

DATA USED IN GENERATING PERFORMANCE
CURVE FOR FLYING SPOT SCANNING SYSTEM

Fiche	4:1 contrast ratio
Objective Lens (diffraction limited)	50 mm diameter #/f = 2 0.8 transmission coefficient
Collecting Lens	0.8 transmission coefficient
*Spot Size on CRT Face	0.001" between 2 σ points
Linear Magnification Factor	0.2
*CRT Beam Current	1×10^{-6} amps
CRT Accelerating Voltage	$2.2 \times 10^{+4}$ volts
CRT Phosphor Dead Voltage	$2.0 \times 10^{+3}$ volts
*CRT Phosphor	P-11
PMT Photocathode	S-20
Multiplier Gain	$1 \times 10^{+4}$
Secondary Emission Ratio of Multiplier Dynodes	2.2
Video Bandwidth	1 MHz
Load Impedance	$1 \times 10^{+5}$ ohms

*From CELCO data

The data supplied by Westinghouse that was used in this analysis and values of other model parameters are present in Table 3-3.

3.1.2.2.4 Performance Analysis of the Laser Scanning System. No specific manufacturer's subsystems or components were selected in analyzing the laser scanning system. The analysis was performed solely on the basis of the generalized data presented in Table 3-4.

3.1.2.2.5 Solid State Scanning System. The solid state arrays selected for use in this analysis were the Reticon* 1872 element photodiode array and the Reticon 512 element photodiode array.

"Combining" these two arrays results in an equivalent 2384 element array which can be used to scan the width of a page on the microfiche. This array size is consistent with the 2320 pixels/line requirement for the scanner.

For the most part, the analytical model developed for the solid state scanning system was not used in this analysis. Only theoretical values for the responses associated with the scanner (i.e. lens MTF, image motion MTF and array MTF) were used. Signal-to-noise data used in this analysis was data supplied by Reticon on the actual arrays. They state that at saturation exposure, the flat field signal-to-noise ratio is 400:1 or better.

The equation used to obtain the S/N vs spatial frequency curve for this system was, therefore,

$$\left(\frac{S}{N}\right)_{\text{scanner}} = k_1 \tau_s \left(\frac{S}{N}\right)_{\text{flat field at saturation exposure}} \quad (3-2)$$

*Reticon Corporation, Sunnyvale, California

TABLE 3-3

DATA USED IN GENERATING PERFORMANCE CURVES
FOR VIDICON CAMERA SCANNING SYSTEMS

Fiche	4:1 contrast ratio
Objective Lens (diffraction limited)	50 mm diameter #/f = 2 0.8 transmission coefficient
*Exposure Level at Photoconductor Surface	7.5×10^{-5} joules/cm ² (2870°K, 1/2 saturation level)
Effective Quantum Efficiency (η_{eff})	0.8
Readout Efficiency	0.9
Video Bandwidth	1 MHz
Load Impedance	$1 \times 10^{+5}$ ohms

PARAMETERS DEPENDENT ON VIDICON SIZE

		1"	1-1/2"	2"
*Output Current for 3 sec/frame readout (at above exposure level)		10 na	26 na	50 na
*Dark Current		0.2 na	0.5 na	1.0 na
*Vidicon Response at:	10 lp/mm	.90	.95	.98
	20	.68	.86	.92
	40	.22	.55	.75
	60	.06	.23	.54
	80	-	.10	.32
	100	-	~ .03	.15
	120	-	-	.07
	130	-	-	~ .04

*From Westinghouse data

TABLE 3-4

DATA USED IN GENERATING PERFORMANCE
CURVE FOR LASER SCANNING SYSTEM

Fiche	4:1 contrast ratio
Objective Lens (diffraction limited)	50 mm diameter #/f = 6 0.8 transmission coefficient
Collecting Lens	0.8 transmission coefficient
Beam Shaping Optics	0.4 transmission coefficient
Spinner	0.4 transmission coefficient
Laser	4.0 milliwatt, He-Ne
*Laser Noise Factor	10
PMT Photocathode	S-20
Multiplier Gain	$1 \times 10^{+3}$
Secondary Emission Ratio of Multiplier Dynodes	2.2
Video Bandwidth	1 MHz
Load Impedance	$1 \times 10^{+5}$ ohms

*From "Noise Power Spectrum Characteristics for an He-Ne Laser Operating under Various Discharge Conditions", A. Waksberg and J. Wood, The Review of Scientific Instruments, Vol. 40, #10, October 1969, pp. 1306-1313.

It is recognized that this equation is very simplistic and can only approximate actual scanner performance in the case where the output noise current is independent of the exposure level. However, in a system such as this, where there is no signal amplification before the preamp, the output noise current generally is independent of the exposure level.

Pertinent data on the Reticon arrays and values of certain other parameters used in this analysis are presented in Table 3-5.

TABLE 3-5

DATA USED IN GENERATING PERFORMANCE
CURVE FOR SOLID STATE SCANNING SYSTEM

Fiche	4:1 contrast ratio
Objective Lens (diffraction limited)	50 mm diameter #/f = 2 0.8 transmission coefficient
Cell Size	3.8 x 3.8 microns (referred to fiche plane)
Image Motion during Integration	3.8 microns (referred to fiche plane)
Exposure Level at Array Surface	1×10^{-5} joules/cm ² (2870°K)
*Flat Field S/N at above Exposure	400:1

*From Reticon data

3.1.2.2.6 Conclusion. As can be seen from Figure 3-3, only three of the candidate scanning systems exhibit the required signal-to-noise ratio of 20:1 or better at the 130 lp/mm operating resolutions. They are:

Laser Scanner

Solid State Scanner

Flying Spot Scanner

These three systems were carried on into the cost and reliability-maintainability analyses. The other scanning systems were dropped at this point.

3.1.2.3 Cost Analysis. A cost analysis was performed on the three scanning systems exhibiting acceptable performance characteristics. This analysis was performed only to the extent of determining an estimate of the relative cost of fabricating each of the three systems.

The procedure used in this analysis was to first establish generalized system block diagrams of each scanner. With the aid of these diagrams, those subsystems and components common to all three systems were identified. Subsequently, those "blocks" common to only two of the three scanners and those blocks unique to each scanner were identified. The system block diagrams are presented in Figures 3-4 through 3-6. Those blocks common to all three scanners have been cross-hatched.

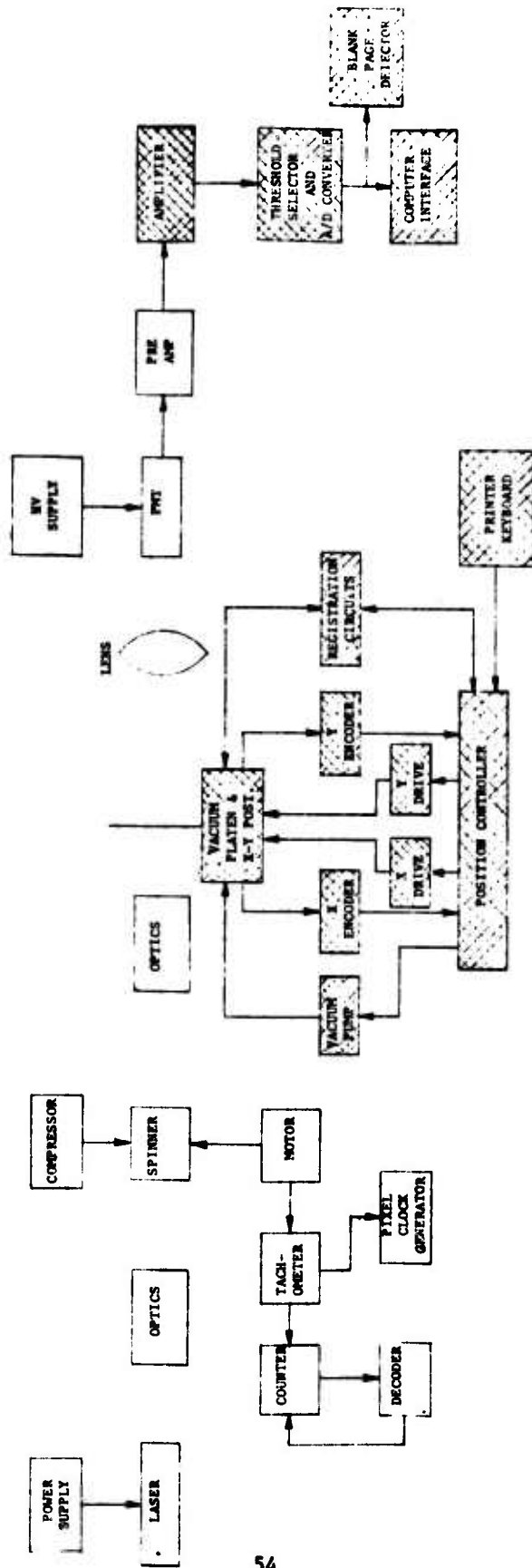

LASER SCANNING SYSTEM BLOCK DIAGRAM

FIGURE 3-4

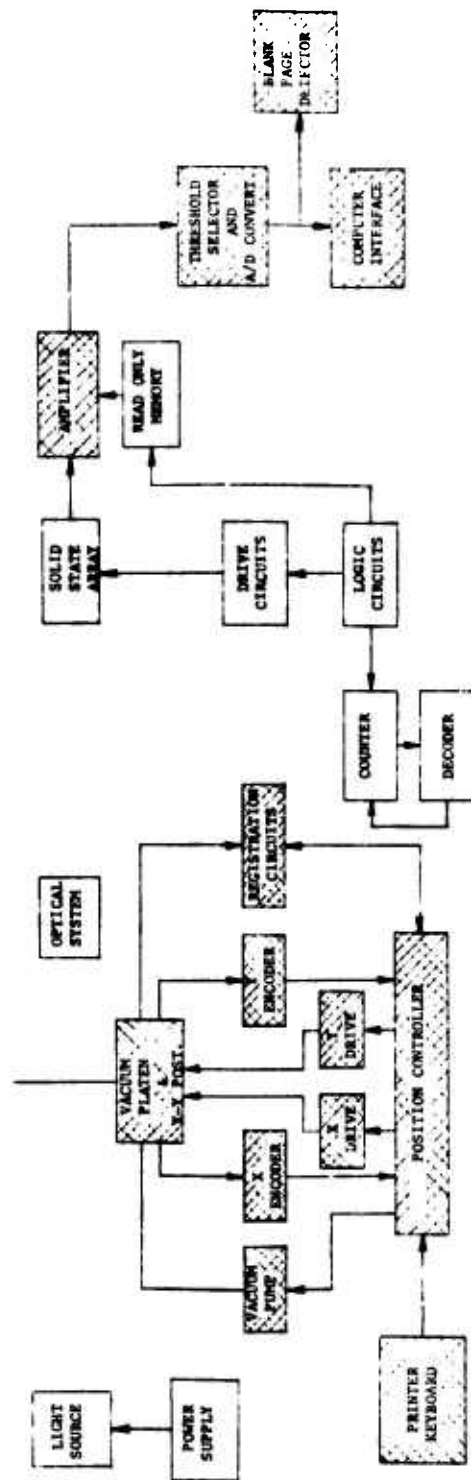

SOLID STATE SCANNING SYSTEM
BLOCK DIAGRAM

FIGURE 3-5

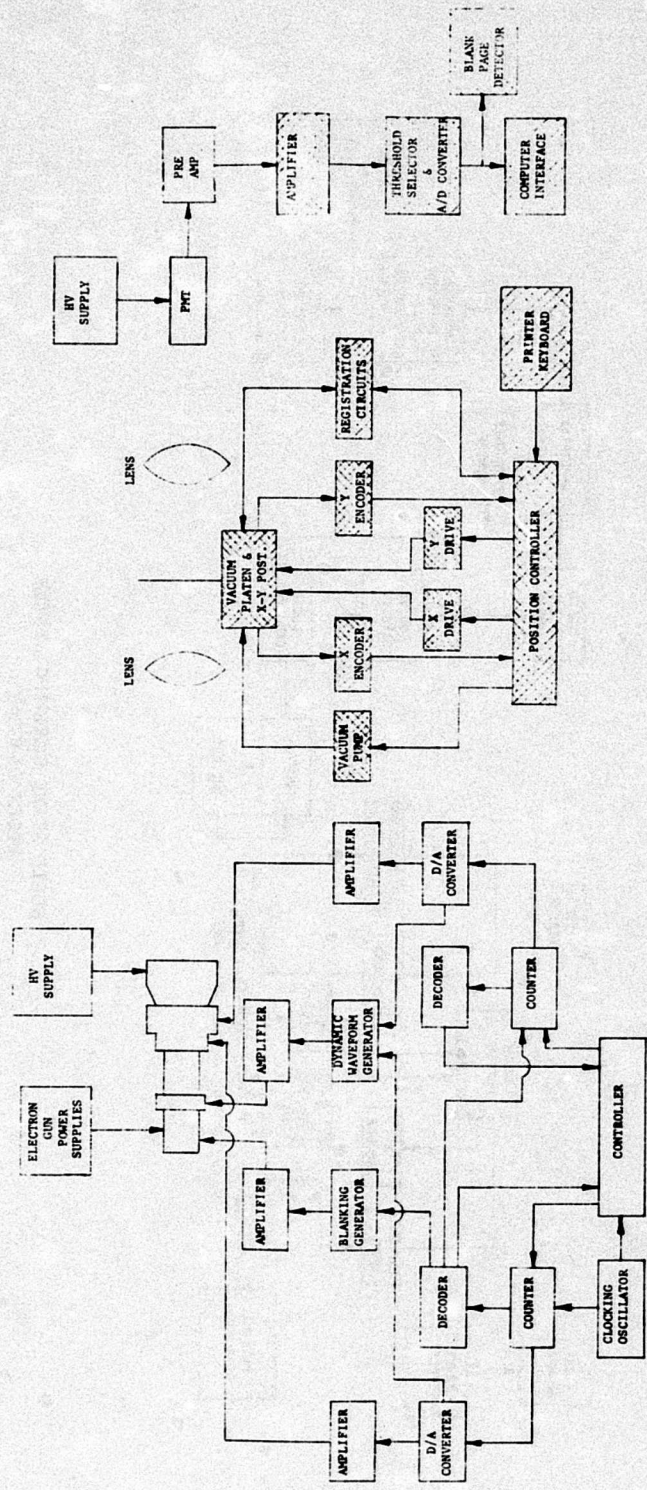

FLYING SPOT SCANNING SYSTEM BLOCK DIAGRAM

FIGURE 3-6

Naturally, those blocks common to all three systems add equally to the cost of all three systems while any unique blocks contribute solely to the cost of that particular system.

An effort was also made to identify and separate nonrecurring (first scanner) from recurring (additional scanners) costs associated with fabricating each scanner.

The results of this analysis is presented in the form of a cost matrix in Table 3-6. Presented in this table are the estimated relative costs of one unit and two units of each of the three scanners. The costs have been normalized with the lowest cost being set equal to "1".

It is apparent from the table that the estimated cost of fabricating the solid state scanner is substantially less than the cost of fabricating either of the other two systems.

TABLE 3-6
SCANNING SYSTEMS COST MATRIX

SCANNING SYSTEMS	RELATIVE COST	
	1 UNIT	2 UNITS
FLYING SPOT	1.5	2.3
LASER	1.4	2.1
SOLID STATE	1	1.4

3.1.2.4 Reliability and Maintainability Analysis. An analysis of reliability and maintainability was performed for each of the three scanning systems selected on the basis of the performance analysis.

The procedures used to predict reliability are generally referred to as the "part failure method" which is based on the premise that system malfunctions are a reflection of part failures. When failures are considered constant over the time period of interest, the system failure rate can be determined by the addition of individual part failure rates (assuming that the elements are connected in series). The failure rates are generally expressed in "failures/10⁶ hours" with the Mean Time Between Failures, MTBF, being the reciprocal of the failure rate.

In estimating maintainability, both preventative and corrective maintenance tasks were considered. Failure rates as determined by the reliability analysis were used to estimate the frequency and type of corrective maintenance tasks. Preventative maintenance tasks were determined from a review and evaluation of components and assemblies of each scanner. The man-hours required for preventative and corrective maintenance tasks were estimated on the basis of in-house experience on similar hardware components and assemblies.

Since detailed designing of each of the three candidate scanning systems was beyond the scope of this program, the reliability and maintainability indices determined from this analysis are only "ballpark" values. However, these values are considered valid for comparative evaluation since additional complexities resulting from such detailed designing would, in general, be common to all three systems.

3.1.2.4.1 Reliability Analysis. The steps that were used in determining the overall failure rates of each of the candidate scanning systems were:

Prepare a reliability block diagram (Note - Diagram does not represent signal flow).

Determine complexity factor for each major block in terms of active parts and quantities.

Determine failure rate, λ , for each active part in terms of failures/ 10^6 hrs.

Perform summation of part failure rates for each block of the reliability diagram.

Determine system failure from summation of block failure rates.

In addition, a common growth factor was included in the predictions for each system. This factor covers presently undefined elements such as interconnecting cables, operating switches, control and status displays, etc.

The results of this analysis are presented in Figures 3-7 through 3-9.

3.1.2.4.2 Maintainability Analysis. The following assumptions were made in estimating yearly downtime for both corrective and preventative maintenance tasks.

The scanner is operated for 2000 hours/year.

The scanner is designed for modular replacement.

Corrective maintenance tasks are, in general, limited to replacement of modules or plug-in circuit boards.

Spare parts are readily available to support the scanner.

Preventative maintenance tasks are performed during normal working hours with the scanner not operating.

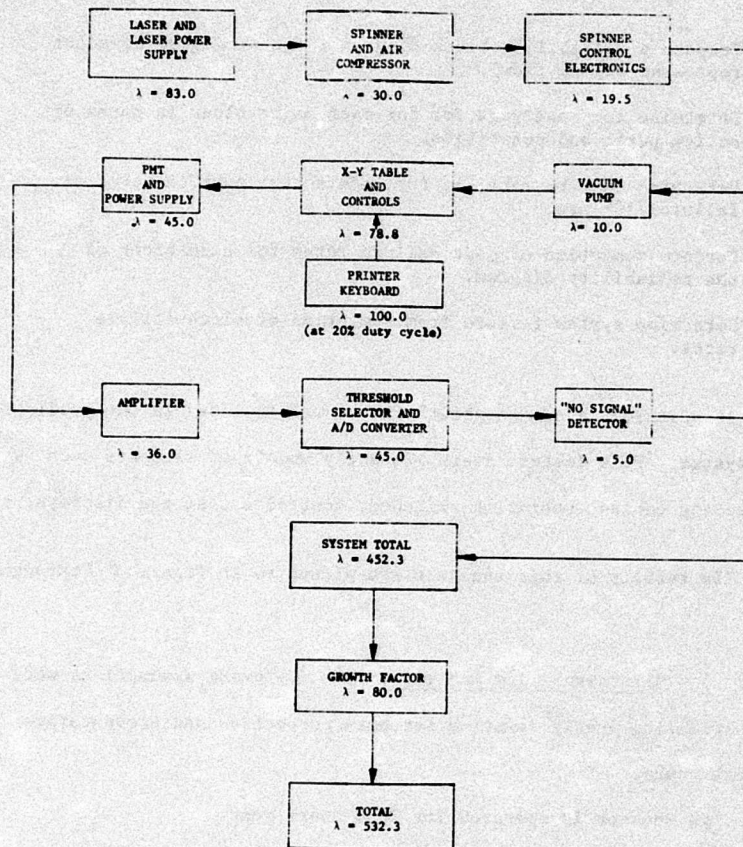

$$\text{MTBF} = \frac{10^6}{532.3} = 1880 \text{ hrs.}$$

RELIABILITY ANALYSIS FOR LASER SCANNING SYSTEM

FIGURE 3-7

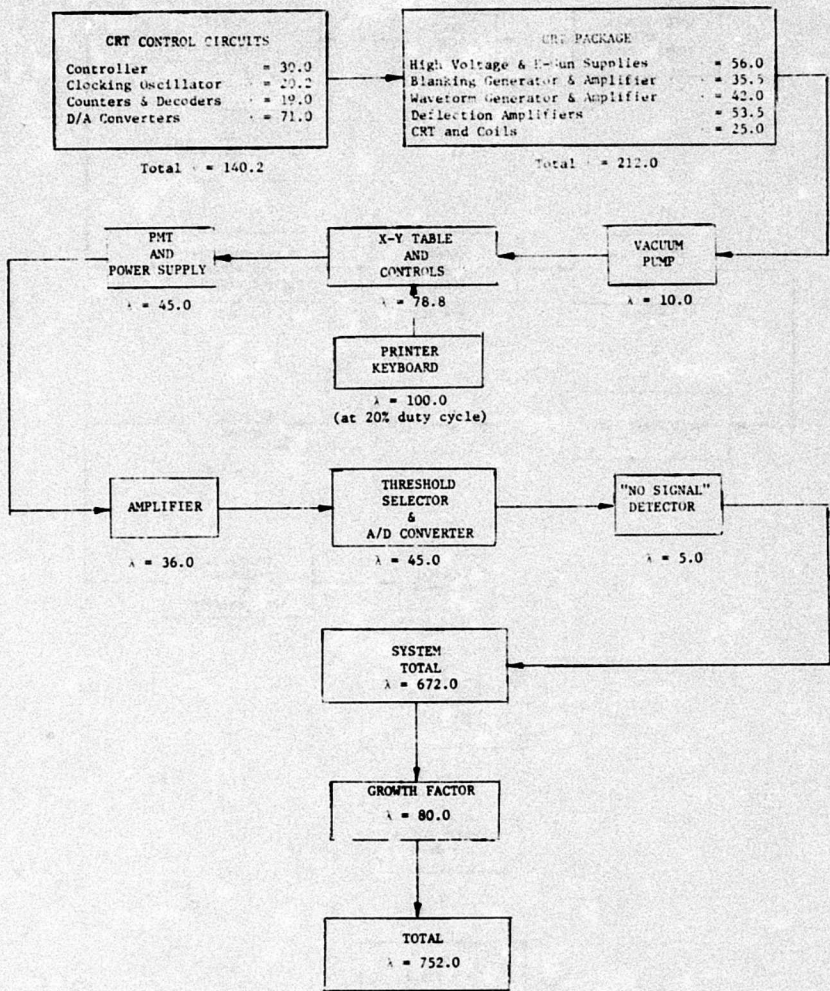

$$MTBF = \frac{10^6}{752.0} = 1330 \text{ hrs.}$$

RELIABILITY ANALYSIS FOR FLYING SPOT SCANNING SYSTEM

FIGURE 3-8

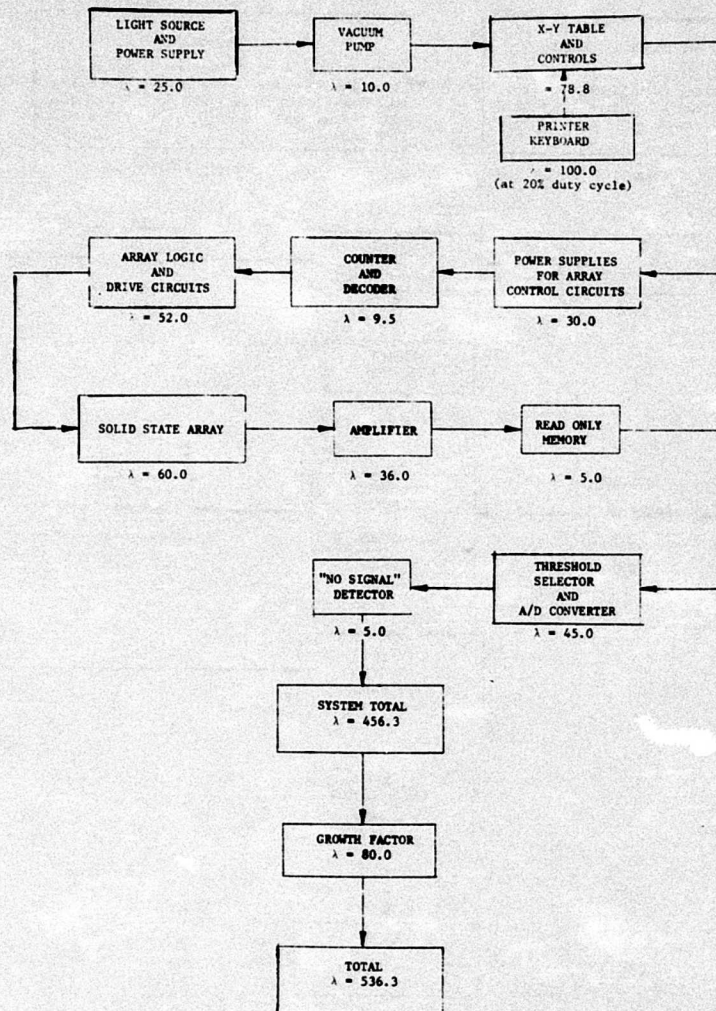

$$MTBF = \frac{10^6}{536.3} = 1860 \text{ hrs.}$$

RELIABILITY ANALYSIS FOR SOLID STATE SCANNING SYSTEM

FIGURE 3-9

3.1.2.4.2.1 Preventative Maintenance Tasks. Preventative maintenance tasks are performed on a periodic basis to assure availability of an operational system with minimum down time. For the three candidate scanners, these tasks are mainly associated with active mechanical components and other components that have limited operational life. Operating tasks (e.g. setting up, adjusting, running and general housekeeping) that are required during use of the scanners are not considered as preventative maintenance.

A summary of the results of this analysis is presented in the first column of Table 3-7. Details of the analysis are presented in Appendix D.

TABLE 3-7
SUMMARY OF MAINTAINABILITY ANALYSIS

SCANNING SYSTEM	MAINTENANCE TIME (Manhours/yr.) [*]		
	PREVENTATIVE MAINTENANCE	CORRECTIVE MAINTENANCE	TOTAL
LASER	78	42	120
FLYING SPOT	64	36	100
SOLID STATE ARRAY	51	28	79

^{*}Based on 2000 hours of operation/year.

3.1.2.4.2.2 Corrective Maintenance Tasks. The time per year, T_{CM} , required to perform corrective maintenance tasks was estimated for each of the candidate scanners using the following formula:

$$T_{CM} = \frac{T}{MTBF} \times \bar{M}_{ct} \times f_l \quad (3-3)$$

where,

T = yearly operating time (2000 hours assumed)

MTBF = Mean Time Between Failure from reliability data

\bar{M}_{ct} = average time for a corrective maintenance task

f_l = learning factor

3.1.2.4.2.2.1 Estimation of \bar{M}_{ct} . The average time for a corrective maintenance task, \bar{M}_{ct} , covers replacement of failed item and retest of the system. Average replacement time, \bar{T}_r , covers such tasks as isolation, disassembly, reassembly, alignment and subsystem checkout.

The average replacement time, \bar{T}_r , in manhours was determined for each scanner using the following equation:

$$\bar{T}_r = \frac{\Sigma(\lambda_1 t_1 + \lambda_2 t_2 \dots \lambda_n t_n)}{\lambda_t} \quad (3-4)$$

where,

λ_t = total failures/ 10^6 hours (Reliability data)

λ_1 = failure rate of applicable block

t_1 = estimated time of repairing each block

The time required for scanner retest is then added to, \bar{T}_r , to obtain values for \bar{M}_{ct} .

3.1.2.4.2.2.2 Estimation of f_L . Experience has shown that, with equipment that has little or no history associated with it, the derived values for \bar{M}_{ct} are generally smaller than the actual corrective maintenance times. This is primarily due to the fact that there is a learning curve associated with repairing such equipment. Some factors that can result in larger values of \bar{M}_{ct} are:

- a. Primary failure results in a secondary failure which requires additional repair time.
- b. During repair for primary cause, repairman observes a condition that in his judgement should be corrected. This "over repair" action increases the total maintenance time.
- c. Repair operations results in secondary or additional failure.
- d. Instructional procedures have not been checked out.

To take into account these various factors, a value of 4 was assigned to the learning factor, f_L .

The numerical analysis used to determine, T_{CM} , for each of the candidate scanners is presented in tabular form in Appendix D. The results of this analysis are presented in the second column of Table 3-7.

The total maintenance time per year associated with each scanner is simply the addition of the times required to perform both the preventive maintenance and the corrective maintenance. These times are shown in the third column of Table 3-7.

3.1.2.4.3 Conclusion. The reliability and maintainability analysis shows that all three candidate scanning systems have low enough "down times" to make them acceptable systems for this application.

From a practical standpoint, the Laser Scanning System and the Solid State Scanning System are identical with respect to reliability and maintainability.

The Flying Spot Scanning System has the largest failure rate (smallest MTBF). The small MTBF is primarily due to the electronic complexity associated with the CRT electronics. However, since the circuit boards making up the CRT electronics are readily replaceable, there is no significant difference in down time between all three systems.

3.1.2.5 Summary of Candidate Scanning Systems Selection Analyses. The results of the selection analyses discussed in the above sections can be summarized as follows:

- a. Only the Laser, CRT Flying Spot and Solid State Scanning Systems exhibit the required performance characteristics for use in this application.
- b. None of these three systems are available as fully developed systems but all can be fabricated from commercially available subsystems and components.
- c. The estimated cost of fabricating the solid state scanner is substantially less than the cost of fabricating either of the other two systems.
- d. The reliability and maintenance effort associated with each of the three systems are such as to make all three systems acceptable for this application.

Based upon this analysis and the above conclusions, the Solid State Scanning System is recommended for use in the Microfiche Scanner and Remote Display System.

3.2 DISPLAY TERMINAL

Of all of the system components the remote display terminal is the only equipment with which the analyst must directly interface. The display terminal, therefore, must be subject to the most critical evaluation. Subjective human factors in addition to functional requirements and performance must be considered during the selection of an appropriate display terminal.

Display terminal selection criteria is established in this section, available display terminal equipment is reviewed, and the most promising units identified. Finally, a display terminal is recommended.

3.2.1 DISPLAY TERMINAL SELECTION CRITERIA

In order to evaluate the display terminal and objectively choose the most suitable unit, a selection criteria based on the system requirements is first established. This selection criteria in conjunction with experimental results will determine the final display selection.

- a. Display Size - The display monitor screen shall be at least 8-1/2 inches wide by 11 inches high so that a standard document on microfiche will be displayed at least full size.
- b. Resolution - The resolution of the display shall be at least 1200 elements at 50% response along the picture height.
- c. Flicker - The display must be flicker-free to prevent operator fatigue. In the case of a non-storage display, the phosphor type and the refresh rate must be optimized to achieve this condition.
- d. Geometric Distortion - Must be less than 1-1/2% over the entire format.
- e. Writing Speed - For storage display types the writing speed must be sufficient to display an entire page within 5 seconds. For refresh tube types, frames must be written at a rate consistent with preventing flicker.

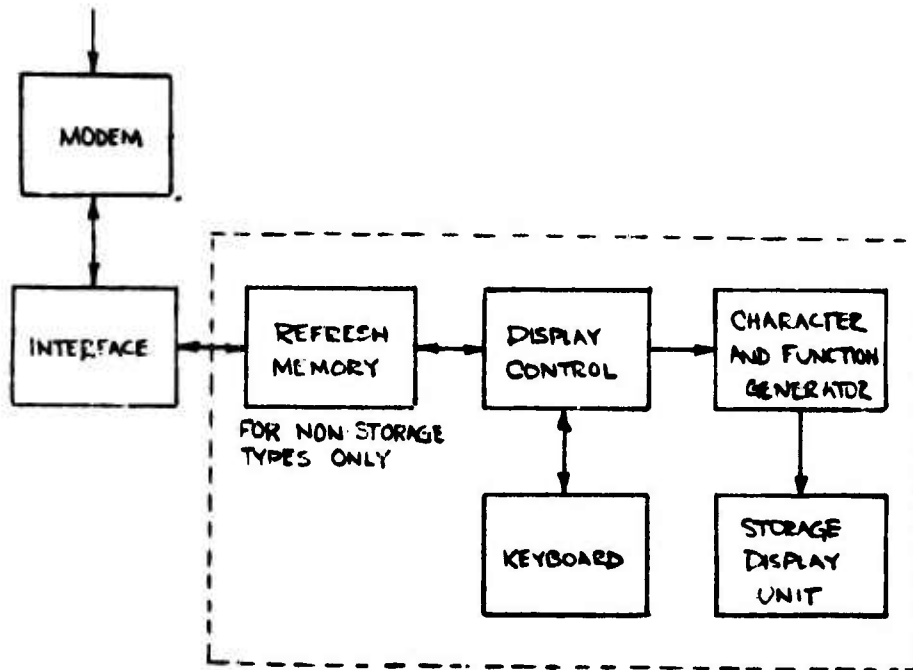

DISPLAY TERMINAL - GENERAL BLOCK DIAGRAM

FIGURE 3-10

- f. Character Generation - The terminal must be capable of providing a complete ASCII character set.
- g. Keyboard - A send-receive keyboard must be provided capable of generating a full ASCII character set.
- h. Mode Change - The display must operate in both a digital and analog mode by keyboard command. Data and commands will be transmitted in the digital mode. Displayed images of microfiche will utilize the analog circuitry (conventional TV raster mode).
- i. Transmission Link Compatibility - The display unit must be compatible with the transmission link modems or interface unit when operating in both the analog and digital modes.
- j. Brightness - The display must have adequate brightness for use in a well lit room. A faceplate light hood may be provided.

3.2.2 DISPLAY TERMINAL TYPES & RECOMMENDATION

Until quite recently the cathode ray tube was virtually the only means for displaying visual information. However, other devices are now available. These display devices include: large screen projection displays, plasma displays, liquid crystal panels, laser holographic approaches and other laboratory developments. Only the CRT's are being considered in this study because they are still the cheapest and most fully developed method of displaying information.

Two types of CRT displays are being considered; the refresh type (non-storage tube) and the direct view storage tube. Both have essentially the same basic block diagram, which appears in Figure 3-10. Common functions include the display control circuits, character and function generators, keyboard and display unit. The "refresh" memory is not required for storage tube types.

TABLE 3-8
COMMERCIAL HIGH RESOLUTION CRT DISPLAYS

DISPLAY UNIT	BALL BEBBS MIKTEL MODEL TH	CONTRAC RQB SERIES	SYSTEMS RESEARCH LAB MODEL 316-14	FUJITSU ULTRA HIGH RESOLUTION TV SET	TELETRONIK Model 9014
SPECIFICATION					
Display Size: H x W	12" x 9 1/2" or 17" x 11" or 17" x 21"	17" 21"	14" 17"	17"	15" x 11" 19"
Resolution:	180 scan lines/line center to center limiting	> 2000 TVL center to center > 1000 TVL corner	center > 2000 TVL corner > 1000 TVL	> 950 TVL both directions	80 lp/inch min 15:10 = 1200 TVL
Scan Lines	525 to 1229 lines	500 to 5000 lines	525 to 1365 lines	1425 lines	VARIABLE IN ANALOG MODE
Bandwidth	-3db at 30MHz	1db 20MHz to 30MHz	to 65MHz	59 MHz	
Phosphor	STANDARD	STANDARD	STANDARD	STANDARD	SPECIAL STORAGE SURFACE
Geometric Distortion	1/2%	< 1%	< 1%	< 1%	< 1%
Brightness		50 FT L (FOR 8 MIL SPOT)	> 100 FT L 4:1 CONTRAST		8 FT-L 6:1 CONTRAST RATIO
Horizontal Frequency	15 kHz to 32 kHz	15 kHz to 40 kHz	VARIABLE	42.75 kHz	5,000 1/4 SEC
Vertical Frequency	15, 20 or 60 Hz	15 to 30 frames	VARIABLE	60 Hz (50 frames)	
Spot Size		< .003" at 50 FT 17" tube			10 MILS
Interlace		4:1 or 2:1	VARIABLE	2:1 LOCKED	—
Storage Type	NO	NO	NO	NO	YES
Keyboard	NO	NO	NO	NO	YES
Notes:			15,000	NOT AVAILABLE AS SUPPLEMENTARY UNIT	SUPPLIED WITH CHARACTER GENERATOR

3.2.2.1 Non-Storage Display - The conventional cathode ray tube comprises the bulk of available display units manufactured. These devices do not store images but rely on the phosphor persistence and rewriting of data or "refresh" at a rate that prevents flicker.

Refreshed CRT terminals are usually of two distinct types; low-cost limited capability, or sophisticated high performance, multi-featured displays. The former are generally limited to about 1000 element resolution. They are not suitable for displaying small text and therefore have no utility for the system under study.

In the sophisticated refreshed CRT system multiple features are added and high performance is generally stressed. These CRT systems take a variety of forms and vary in intelligence. Some are supplied as video monitors; others have character generators, graphics stroke generators, refresh memories, and send/receive keyboards. A number of systems are packaged as complete graphic systems including the host computer and software. The systems vary widely in resolution, format size, cost and other specifications.

In selecting CRT systems for consideration, the resolution capability was first used to pull out unacceptable units. By applying the criterion of 1200 elements resolution per picture height - which is an absolute minimum for acceptable document legibility - the number of available displays was sharply reduced. Table 3-8 lists the displays that appear to have sufficient resolution to display microfiche documents. The major display characteristics are also listed.

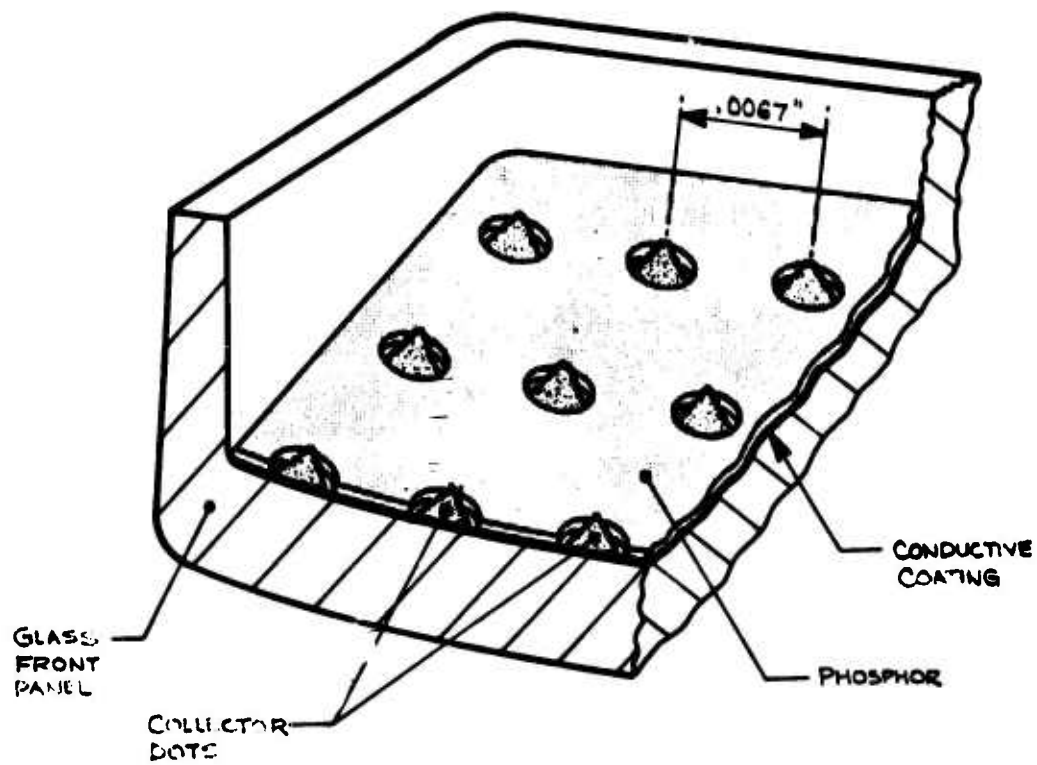

TEKTRONIX #4014 DISPLAY TERMINAL TARGET STRUCTURE

FIGURE 3-11

3.2.2.2 Direct-View Storage Display - The direct-view storage display also represents a candidate CRT display applicable to the Microfiche System. This display has the ability to store information on the phosphor screen. Video information only has to be transmitted once to be stored. This eliminates the need for a local memory and associated refreshing circuitry and results in a flickerless display which does not cause fatiguing image motion effects.

A number of storage CRT displays are manufactured by different vendors. The unit that appears most suitable in terms of performance and cost is the Tektronix Model #4014 Display Terminal. This terminal has an 11 inch x 15 inch storage screen capable of over 1500 element resolution (15 inch dimension) under controlled operation. The display terminal has a full ASCII keyboard and 5 x 7 dot matrix character generator. Interfaces are available which allow operation in both an alphanumeric/graphical or analog (conventional TV raster) mode. The unit is extremely attractive from a human factors viewpoint as it has a high contrast, bright (to the human eye response), motionless display. A hard copy unit can also be added.

The bistable storage screen is the unique element of the direct-view storage CRT that allows storage. The theory of operation is well documented in the literature^{(1), (2)} and will not be repeated here. The Tektronix #4014 Display Terminal has a "raised-collector" target (screen) structure, shown in Figure 3-11, with a 6.7 mil array pattern that tends to quantize the stored spot. Thus the minimum spot size obtained, when writing at a controlled rate, can be inscribed in a 6.7 x 6.7 mil square.

(1) "Storage Cathode-Ray Tubes & Circuits", Tektronix, Inc.
Publication 1969

(2) B. Kazan & M. Knoll, "Electronic Image Storage", Academic Press 1968

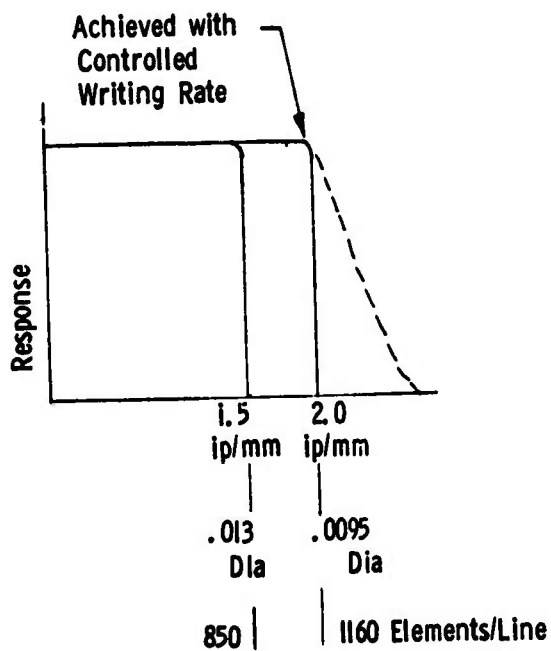
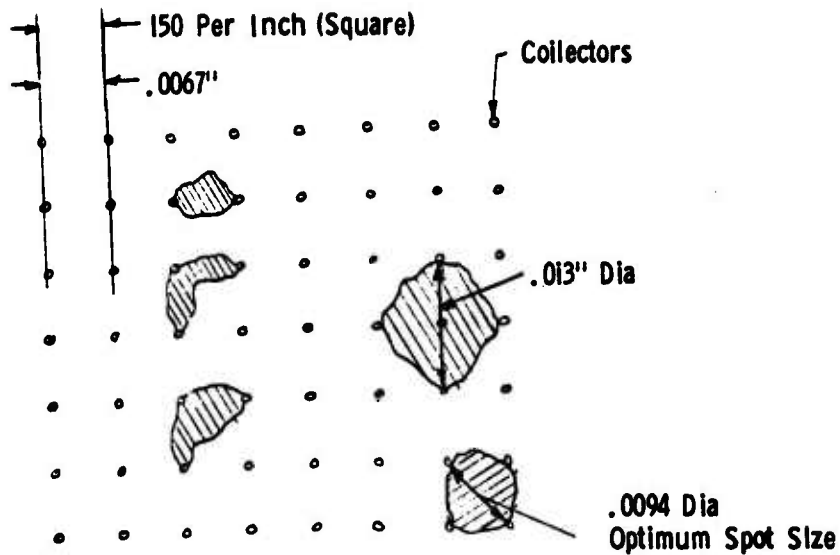

TEKTRONIX STORAGE DISPLAY RESOLUTION

FIGURE 3-12

Figure 3-12 illustrates the limiting resolution of the #4014 Display as being approximately 1160 elements per line (11" width) for an optimum spot diameter of about 0.009 inches. This is equivalent to more than 1500 elements across the picture height. Writing at a slower rate, or with more beam current, will generally produce a larger spot. Less beam current produces a pronounced quantizing effect and causes triangular shaped patterns such as illustrated on the left. By using a controlled writing rate, the optimum resolution can be maintained over the entire display screen.

Many simulation experiments (described in Appendix B) were performed during this study using the Tektronix #4014 Display Terminal. The tests confirmed the superiority of the #4014 and resulted, after conducting an overall assessment, in its selection as the recommended display terminal.

3.2.2.3 Display Terminal Recommendation - The Tektronix #4014 Display Terminal is the recommended unit for the Microfiche Scanner and Remote Display System. In summary, its performance proved to be superior to non-storage displays in comparative tests. It is capable of high resolution, can store an image for long periods of time, has a large format, is very conservative of bandwidth, and displayed data can be readily zoomed. The display had considerable viewer appeal during simulation demonstrations for FTD and RADC personnel, primarily because of its flicker-free, bright, high contrast performance. The unit has a built-in keyboard and function generators and can be vertically mounted. It doesn't require a refresh memory. The display terminal is commercially available at reasonable cost with a one year guarantee. Tube life is several thousand hours (replace tubes can be purchased).

3.2.3 BUFFER MEMORY FOR NON-STORAGE CRT DISPLAY

During the search for a suitable non-storage CRT display, a comparison was made of the various types of buffer memories available, since all non-storage type devices have to be constantly refreshed to prevent the image from fading. Therefore, each CRT terminal either has to receive a data image repeatedly and at a high rate from the computer or else has to have its own refresh image buffer. Since the computer can not transmit data at the required rate (even if it could, the situation would be impractical as the computer would be tied up for as long as a terminal user was viewing an image), the choice has to be individual refresh buffers.

The buffers were all compared using the assumption that a CRT would be capable of displaying 1350 lines each with 1200 elements of information or 1.62×10^6 bits of information (these were preliminary parameters used early in the study). Depending on the frame rate and interlace scheme selected (which are contingent on the acceptable screen flicker rate), the buffer must be able to transmit data at a rate somewhere between 15 and 50 megabits/second. Data capacity and data rate, then, are the two main requirements which any refresh buffer must meet. The cost data supplied is meant only for comparison purposes as these prices are continually changing.

Note that this section has been included to provide thorough documentation of the study results. Since a storage CRT display has been recommended, a buffer memory is not required in the system.

3.2.3.1 Memory Types. There are a variety of memory types available which are adaptable for use as refresh buffers. These devices include:

- a. Magnetic Disc Storage
 - 1. Floating head
 - 2. Fixed head
- b. Magnetic Core storage
- c. Solid-state random access memory
 - 1. Static
 - 2. Dynamic
- d. Solid state shift register
- e. Analog storage tube

With the exception of the analog storage tube, all of the above devices operate at well below a 10 megabit/second rate. However, this deficiency can be overcome by the use of multiplexing and/or extending word size. That is, by having a large number of bits per word and operating multiple channels in parallel. The following is a brief comparison of the above storage methods:

3.2.3.1.1 Magnetic Disc Storage. Floating Head - For the system under consideration, magnetic discs are available with a data capacity much greater than required. A typical disc system transmits data in the order of 5 megabits/second. In a floating head device, only one pick-up head is used, being mechanically transported to the desired track, so that data cannot be obtained from more than one track at a time resulting in a maximum output rate of 5 megabits/second which is inadequate for our purposes.

Fixed Head. Discs with fixed heads, i.e., one head for each track, are also available with sufficient storage capacity. In this case, however, a number of output tracks may be selected in parallel so that 10 tracks would have an output rate equivalent to 50 megabits/second. Such a unit is priced in the \$12,000 range.

The nature of this device, which is not unlike 10 shift registers in parallel with an unvarying clock rate, is such that data must be input at the same rate as it is taken out, 50 megabits/second in our example. Therefore, a queuing buffer would have to be added before the disc input to compensate for differences in the disc input rate and the computer memory output rate, adding to the overall system cost and complexity.

3.2.3.1.2 Magnetic Core Storage. An established technique of data storage is by the use of magnetic core. The cycle time of a typical device is about 750 nanoseconds. If the memory format is arranged to have a 40 bit word, then the memory output bit rate is 40 bits/750 nanoseconds or 53.3 megabits/second. This rate is an upper limit and both the input and output rates can be changed independently. Also, no additional buffering is required as these are random access type memories and thus require essentially no waiting time to input data. The price for a 48K by 40 bit configuration is about \$13,000.

3.2.3.1.3 Solid State Random Access Memory. Static RAMs - Static RAMs are relatively expensive, but do not require constant memory refreshing as do dynamic devices. They are most useful in small systems because of the fact that many additional support components are not required. A 1.6 megabit system capable of 3.3 megabits/second costs about \$13,000 while one capable of 2 megabits/second costs about \$9,500.

Dynamic RAMs. Although dynamic RAMs require constant refreshing, necessitating extra circuitry, they have many advantages over static RAMs. They are cheaper, have faster operating times, use less power, and are available in higher bit densities per chip. One kilobit static chips are standard compared to four kilobit dynamic RAMs. Using such high density chips, a 1.5 megabit dynamic RAM memory can be purchased for around \$10,500. Available systems are organized as 32K x 8 bits per board and are TTL compatible.

3.2.3.1.4 Solid State Shift Registers. Charge Coupled Device (CCD) shift registers provide an attractive method for constructing a refresh memory. They are dynamic devices (requiring a minimum shift time) which is of little consequence in this application and are, of course, a serial access type of memory as is a disc. However, the input and output clock rates can be varied so that no additional buffering is required as in the case of magnetic discs. A 1.6 megabit system would cost approximately \$8,500.

3.2.3.1.5 Analog Storage Tube. This device stores analog data and operates in a manner analogous to a standard picture tube. However, in this case the electron beam is directed to a charge-stored target, instead of a viewing screen,

TABLE 3-9

CRT REFRESH MEMORY CANDIDATES

Company	Pettec Corp.	Date Disk	Standard Memories	Electronic Memories	Monolithic Systems Corp.	Intel	Hughes Aircraft Corp.
Memory Type	Magnetic Disc Floating Head	Magnetic Disc. Fixed Head	Magnetic Cores	Solid State Dynamic RAMs	Solid State Dynamic RAMs	CCD Shift Register	Analog Storage Tube
Bit or Byte Rate/Second	5 Megabit	5 Megabit	1.3 Megabyte	3.3 Megabyte	5 Megabyte	2 Megabyte	30 Megabyte
No. Channels or Bits/Byte	1 Channel	16 Channels	40 Bits	20 Bits	16 Bits	32 Bits	1 Channel
Equivalent Bit Rate	5 Megabit	80 Megabit	52 Megabit	66 Megabit	80 Megabit	64 Megabit	30 Megabit
Additional Buffering Required	Yes	Yes	No	No	No	No	No
Size (No. Bits)	100 Megabits	2.72 Mega-bits	1.966 Mega-bits	1.6 megabits	1.536 Megabits	1.6 Megabits	1.058 Megabits
Approx. Cost	\$9,150	\$12,145	\$13,580	\$13,175	\$10,500	\$8,440	\$4,300

from which the data can be read out at a later time and at a different rate. Thus, these devices are also known as scan converter tubes. The upper operating limit of these tubes is 30 megahertz with reliable operation taking place with a resolution of 1029 elements per line x 1029 lines. Higher resolution tubes have been made (at greater cost) for special applications and can be obtained under certain conditions (e.g., in multiple quantities). However, they are considered, at this time, to be highly sensitive devices and would require factory maintenance to be performed on a monthly basis.

3.2.3.2 Refresh Memory Summary. Table 3-9 gives a comparison of various possible memory types which are available today and can be considered as reliable devices. All of these devices would require additional control circuitry such as formatting logic, clock generators, address control, D/A conversion, etc. The cost comparison is based on the requirements of the application under consideration. The important items of consideration are the relative capacity, speed, and cost.

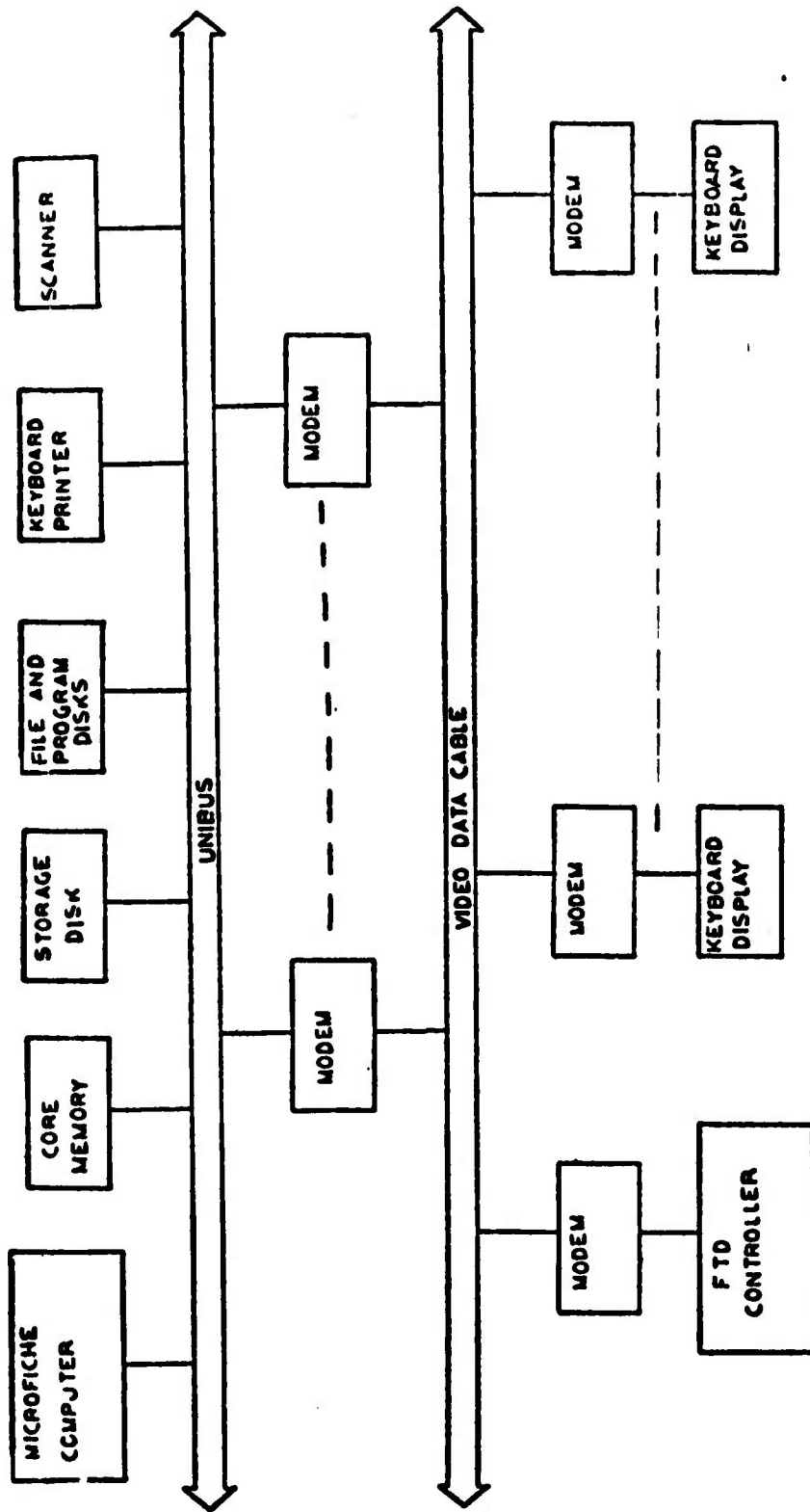

SYSTEM BLOCK DIAGRAM - GENERAL

FIGURE 3-13

3.3 ALTERNATIVE MICROFICHE SYSTEM CONFIGURATIONS

A number of alternative Microfiche System communication configurations have been assessed during the preliminary definition. The different configurations consider various transmission equipment arrangements and attempt to optimize the trade-off between system performance, total equipment requirements, cable bandwidth utilization, and software complexity. All alternatives are configured to be compatible with the specific requirements imposed by the FTD Information Systems upgrading plan.

3.3.1 BASIC COMMUNICATION ARRANGEMENT

A simplified illustration of the Microfiche System's major components and the method of communication is shown in Figure 3-13 . Image data control is handled by the microfiche computer processor. The magnetic core memory is used to provide data input and output buffers and also to hold the operating programs. A rotating dual port magnetic disk memory system will store all of the image data scanned from the microfiche input. Additional, but smaller, disk systems are provided to hold the various system programs including assignments of image data locations on the dual port disk. A keyboard printer allows an operator in the microfiche storage center to receive data requests and also to enter information into the system pertinent to the image being scanned; e.g., a microfiche identification number, number of pages, etc.

The scanning device accepts manually loaded microfiche, scans them a page at a time, and transmits digitized data to the microfiche processor. An intercommunication path for these devices is provided by the computer Unibus system, which is a high speed data transmission facility. It is, in fact, required that the scanner portion of the system be located physically close to the computer in order to take advantage of the high speed characteristics of the Unibus and thus, in effect, be hard-wired to the computer.

The remaining system components (display terminals and FTD concentrator) will be located physically far apart due to the geographical layout of areas requiring displays within the building complex. Therefore, since it is impractical to hardwire all of these devices together, a two-way coaxial cable with a high bandwidth is used as the data transmission system. One or more modems can be used to interface any system component to the coaxial cable. The modem is used to modulate a high frequency carrier with digital data at the sending end and demodulate the carrier at the receiving end. Appropriate interfaces must be used with different types of devices and/or modems.

A user will have a display and an input keyboard at his disposal to communicate with the system. Data will be presented to the user on a large screen when requested by use of the keyboard. Such data may be requested

either from the stored microfiche data, i.e., (images which must first be entered into the system and scanned or images which are already stored on the processor disk system) or from the library portion (IBM 360) of the system already installed at FTD.

The FTD concentrator (a DEC PDP 11/45 mini-computer) is responsible for all traffic control. It assigns system devices to the appropriate transmission channels and routes request and status information between the terminals and the microfiche and library processors.

In all the alternatives that follow, a primary requirement will be that high speed transmission must be accomplished between any one of up to 100 display terminals and any one of six microfiche computer output channels.

There are a variety of ways in which the system can be configured to take advantage of available communication components and optimize performance. These methods will now be explored.

3.3.2 POINT-TO-POINT CONFIGURATION

Figure 3-14 illustrates a scheme in which each display terminal has a unique transmission channel assigned to it, resulting in a total of 106 high speed transmit-receive channels. Six channels operate between the microfiche computer and the concentrator and the remaining 100 channels are between the concentrator and the display terminals. Thus, image data originating at the microfiche computer is first transmitted to the concentrator which then assigns it to the proper channel in order that the

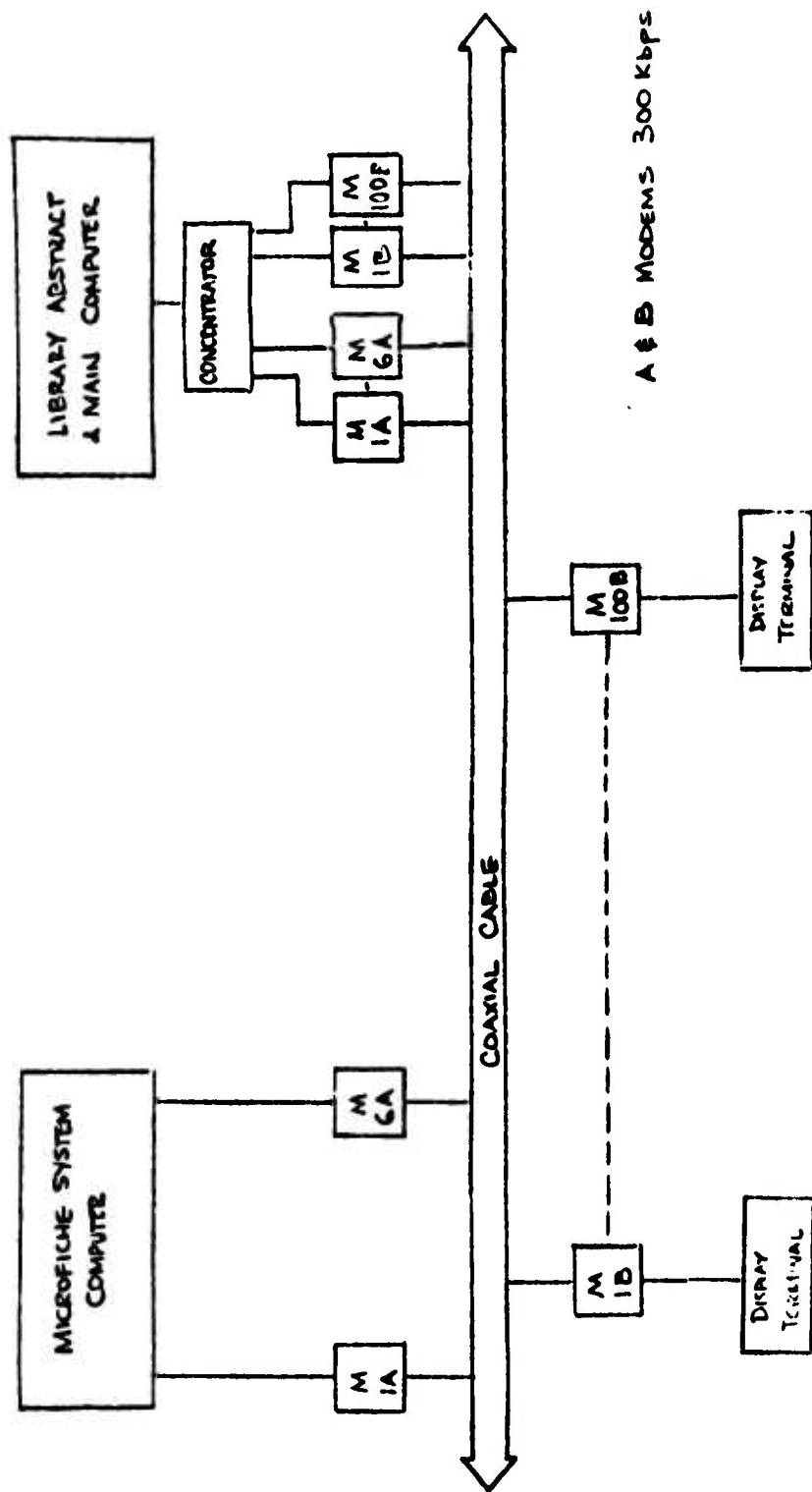

POINT-TO-POINT CONFIGURATION

FIGURE 3-14

correct terminal can receive the data. In this manner, any channel can respond to any terminal. In addition, the concentrator handles all messages passing between the display terminals and the library computer. All transmission takes place on high speed channels.

This method has a number of weaknesses. First, the number of high speed channels in use would consume so much of the cable bandwidth that the transmission system would have to be dedicated to the microfiche system and no other information system would be able to make use of it. In addition, the concentrator would have to act as a multiplexer-demultiplexer requiring more program functions and core memory. Also, at the data rates anticipated, the concentrator would be overloaded, and unable to handle all the inputs and outputs. Finally, just attempting to attach over 100 peripheral devices (including interfacing) to the concentrator would present an expensive logistics problem. For these reasons, then, the concept was quickly abandoned.

3.3.3 MULTI-DROP CONFIGURATION

The method shown in Figure 3-15 represents an improvement over the previous alternative in that the number of high speed channels is considerably reduced. This is accomplished first by not sending image data through the concentrator but instead transmitting it to six receive-only high speed modems. Then, to each of these receive-only units are assigned a group of terminals (approximately one-sixth of those in the system) which are multiplexed to the modem in the time division mode. Now there are only six high speed channels, each servicing a group of terminals. The six modems at the microfiche computer

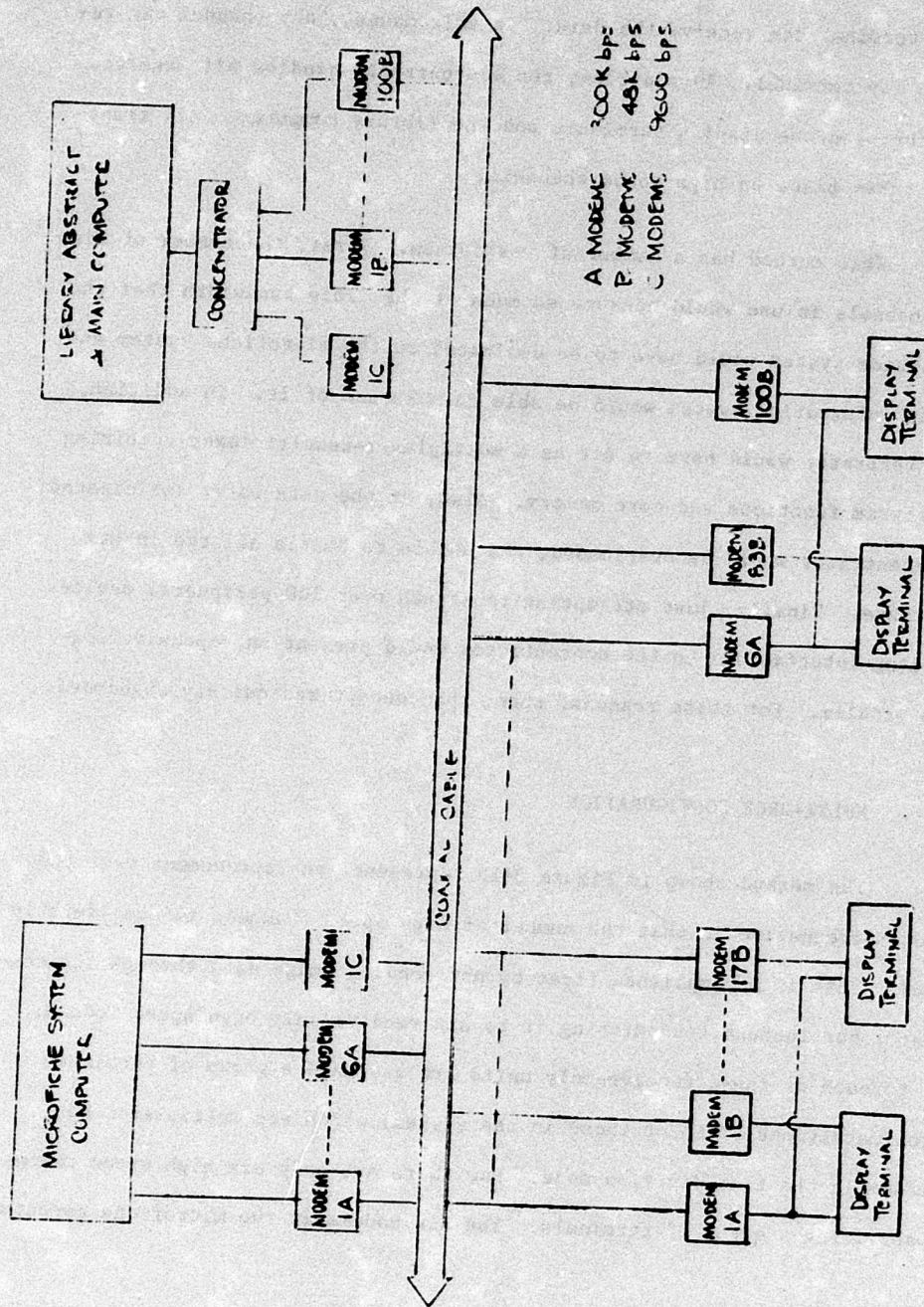

MULTI-DROP SYSTEM CONFIGURATION

FIGURE 3-15

output are send-only units. In addition, each terminal also has access to a 48 kilobit/second transmit-receive modem, each operating on a unique carrier frequency or channel. The concentrator has matching 48 kilobit/second transmit-receive modems and it is over these lower speed channels that data requests, library data, and status signals are conveyed. In addition, commands are sent to instruct a particular terminal to accept data arriving on its assigned shared high speed channel. A low speed 9600 baud modem is used to allow communication between the microfiche computer and the concentrator. The concentrator then routes requests and instructions for data channel assignments.

This scheme has a number of advantages and disadvantages compared to the method described in the previous section. When evaluated, this approach can be seen to be the better choice of the two.

The principle advantage of this configuration is the reduction of high speed channels to a total of six. Since these are the image transmission channels, they are in use a greater portion of time, but now occupy only a nominal amount of the available cable bandwidth (approximately 15 megahertz). In addition, the concentrator is no longer overloaded, although it still requires increased program and memory capacity for its role as a multiplexer-demultiplexer.

While the major objection of the point-to-point method (in terms of bandwidth considerations) has been overcome, so that this is a viable approach, there are still a number of disadvantages which result in an overall unsatisfactory system. Each group of terminals multiplexed to a receive-only high speed modem must be hardwired to that device. This is both inconvenient and expensive. Also, if one high speed modem becomes defective, then

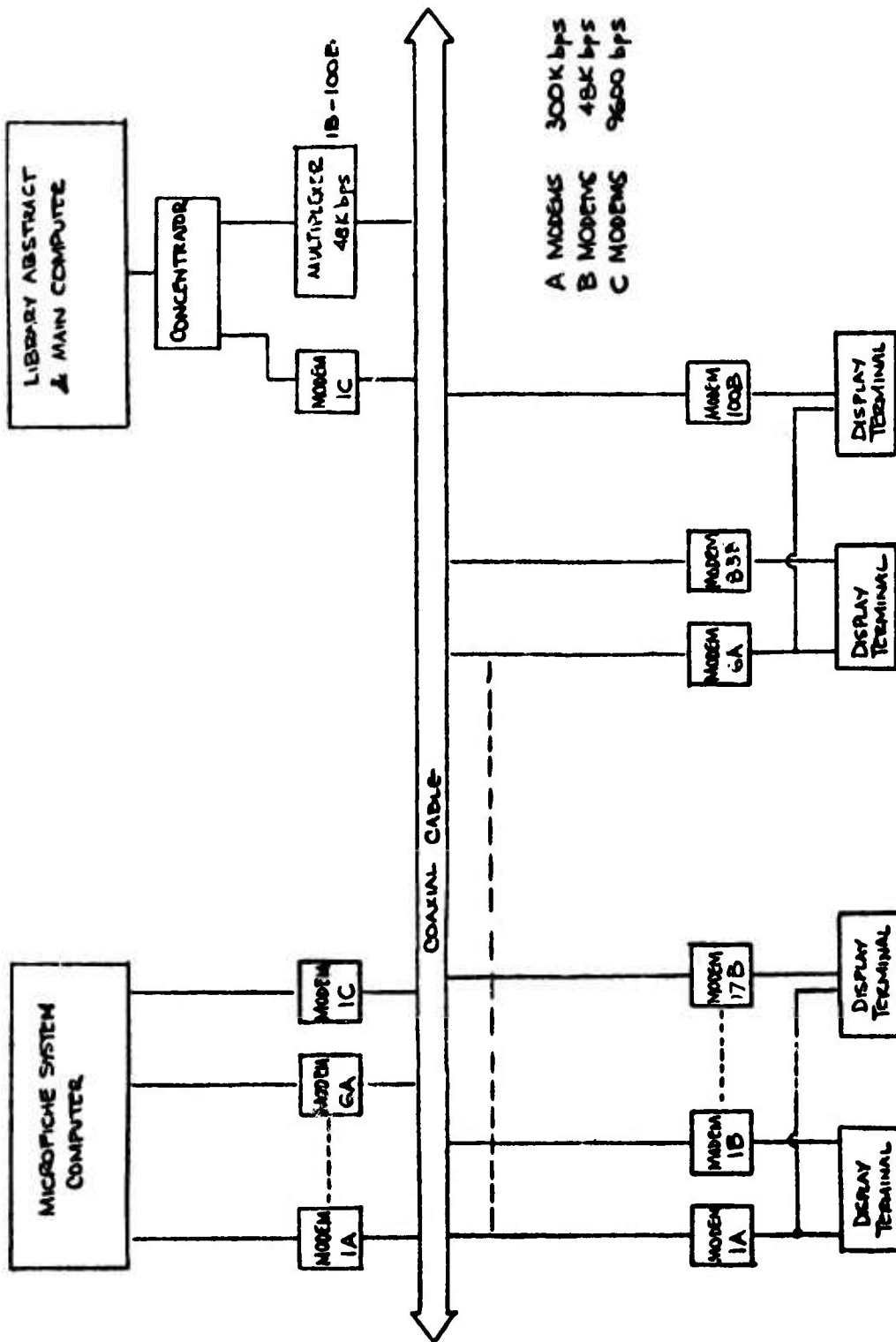

MULTI-DROP SYSTEM CONFIGURATION
WITH MULTIPLEXER FOR 48 Kbps MODEMS

FIGURE 3-16

the complete group of terminals associated with that modem also become inoperative. (An alternative solution might be to have each terminal in a group have a high speed modem, all assigned to the same carrier frequency, but, then the same problem occurs if an output modem from the microfiche computer fails). The addition of the 48 kilobit/second modems presents a bandwidth problem again, although not nearly as serious as in the point-to-point method. In this case, the 100 two-way channels would occupy approximately 30 megahertz of the cable frequency spectrum, undesirable, but not out of reason. Of course, the concentrator still has the problem involved in handling all 100 modems which, although causing both software and hardware difficulties, are not insurmountable.

Therefore, while the simple multi-drop configuration is seen to be a feasible technique, there still remain a number of undesirable features which should and can be overcome. Some of these unwanted features can be resolved as described in the following sections.

3.3.4 MULTI-DROP CONFIGURATION WITH MULTIPLEXER

The diagram in Figure 3-16 is similar to the Multi-Drop Configuration except that the 100 modems attached to the concentrator have been replaced by a 48 kilobit/second multiplexer. Addition of the multiplexer frees the concentrator from interrogating the terminals (via the 48 kilobit modems) and assembling their messages as the multiplexer is designed to perform these functions. The 48 kilobit/second modems are now time division multiplexed and use only one transmit-receive channel for a cable bandwidth requirement of approximately 300 kilohertz. Providing a multiplexer permits use of less equipment, lowers

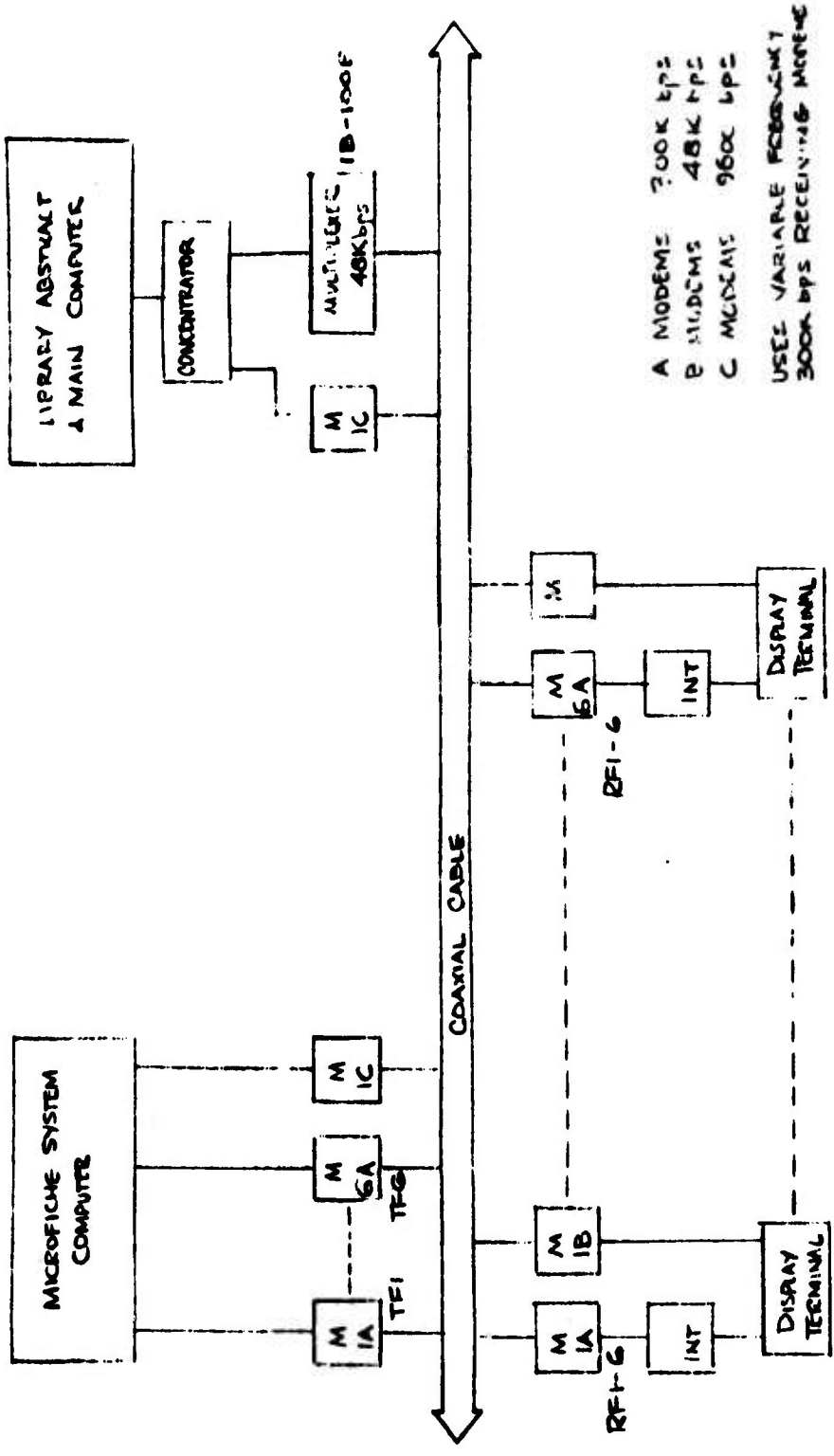

SYSTEM CONFIGURATION WITH DYNAMIC CHANNEL ALLOCATION

FIGURE 3-17

bandwidth requirements, and reduces the load on the concentrator. This, then, is an approach superior to either of the ones initially tried.

3.3.5 TERMINAL RANDOM ACCESS CONFIGURATION

The final and recommended configuration is illustrated in Figure 3-17. This method also makes use of a multiplexer for the 48 kilobit/second channel. Now, however, instead of groups of terminals being hardwired to a particular single high speed channel modem, each terminal contains its own high speed receive-only modem. These modems are unique in that they can be electronically commanded to demodulate data on any one of the six transmitting high speed channels. Therefore, in effect, any one or more of the 100 terminals can be connected to (that is, receive data from) any one of the six microfiche transmitting channels.

To summarize, this last solution has the following advantages and improvements as compared to previous approaches:

- a. Any display terminal can receive data from any of the high speed output channels.
- b. Minimum cable bandwidth requirements for both the 300 kilobit/second and 48 kilobit/second modems has been achieved.
- c. Failure of a single modem does not impair a large portion of the system.
- d. All units are connected to the coaxial cable transmission system.
- e. The concentrator controls the traffic flow.
- f. If the system is initially configured with only a few terminals, more terminals can be added at any time without regard to geographical location as is the case in a multidrop situation.

This system configuration is recommended for use in the Microfiche Scanner and Remote Display System as it meets all the system requirements in terms of convenience, flexibility, expense, and capacity.

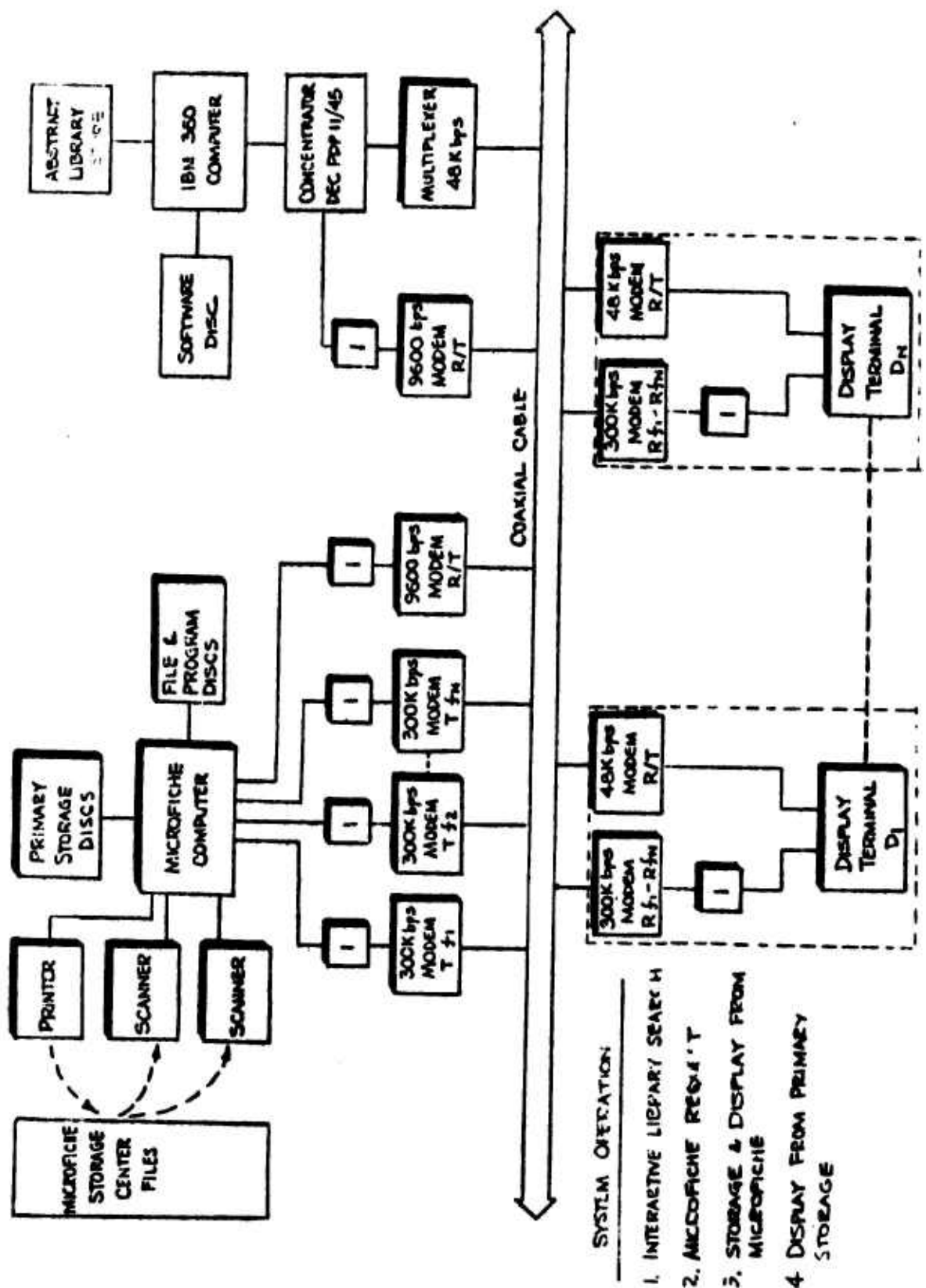

- SYSTEM OPERATION**
1. INTERACTIVE LIBRARY SEARCH
 2. MICROFICHE REQUEST
 3. STORAGE & DISPLAY FROM MICROFICHE
 4. DISPLAY FROM PRIMARY STORAGE

MICROFICHE SCANNER AND DISPLAY SYSTEM BLOCK DIAGRAM

FIGURE 4-1

4.1.1 INTERACTIVE LIBRARY ABSTRACT SEARCH DATA FLOW

Action begins at a display terminal when a user types in a request for information on a particular subject. As shown in Figure 4-2, the request is transmitted via the coaxial cable, after being modulated by a 48 kilobit/second modem, to the 48 kilobit/second modem multiplexer. When the multiplexer has assembled a complete abstract request message, it transmits the message to the concentrator. The concentrator decodes the address in the message preamble and routes it to the IBM 360 computer which proceeds to search for and retrieve the requested data.

Once the desired data is found, the above procedure is reversed. The message containing the requested information is sent from the IBM 360 computer to the concentrator. The concentrator transmits it to the multiplexer which relays the message to the correct modem via the coaxial cable. After the modem demodulates the high frequency carrier, the message containing the abstract information originally requested is displayed on the output screen. The analyst notes the microfiche index numbers corresponding to the documents of interest. These index numbers are used to initiate microfiche image requests from the microfiche computer.

4.1.2 MICROFICHE REQUEST DATA FLOW

The next step in the operation is to request that the desired microfiche be entered into the system. Again, this is initiated by a display terminal user who types in the request and pertinent information (e.g. microfiche identification number). Using Figure 4-3, it can be seen that, as before, the message is modulated by a 48 kilobit/second modem, transmitted over the cable to the

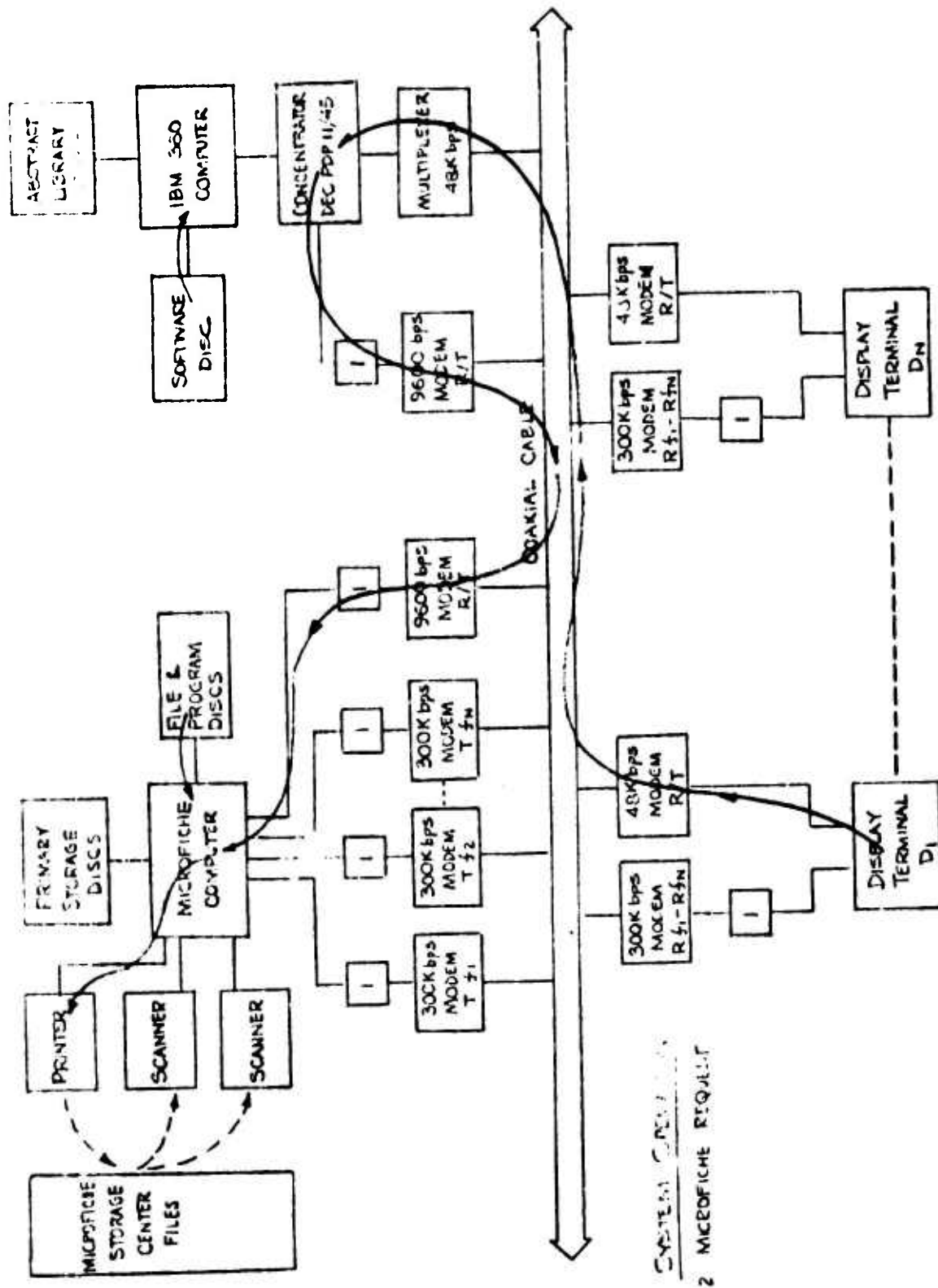

DATA FLOW - MICROFICHE REQUEST
 FIGURE 4-3

multiplexer, and again received by the concentrator. This time, upon decoding the message preamble, the concentrator determines that the message is to be sent to the microfiche processor, which it proceeds to do by means of the coaxial cable and a pair of low speed 9600 baud modems. The microfiche processor accepts the message, decodes more of the preamble, interrogates its index file to determine whether the data is already in the system and when it discovers that new information is being requested, routes the message to an output printer in the scanner area adjacent to the microfiche card storage files. An operator then reads the message and obtains the desired microfiche card.

The need for the low speed transmission link between the microfiche computer and concentrator arises because of the location of facilities in the FTD building. The two computer facilities will be located on different floors quite a distance apart and, therefore, must utilize the coaxial cable system as an interconnection.

4.1.3 MICROFICHE STORAGE AND DISPLAY DATA FLOW

At this point, the operator at the microfiche storage center inserts the microfiche card in a scanner unit, enters appropriate data (scanner number, microfiche identity, etc.) using the keyboard on the printer and starts the scanning process. The digitized and preformatted scan data is accepted by the microfiche processor and recorded on the primary storage discs as illustrated in Figure 4-4. Information regarding image location on the storage disc is recorded in the index file. As soon as the first page of the microfiche card is stored on a disc, it is retrieved by the processor and transmitted over the cable via a pair of high speed (300 kilobit/second) modems to the requesting display terminal. The demodulated image data is then scanned out on the terminal

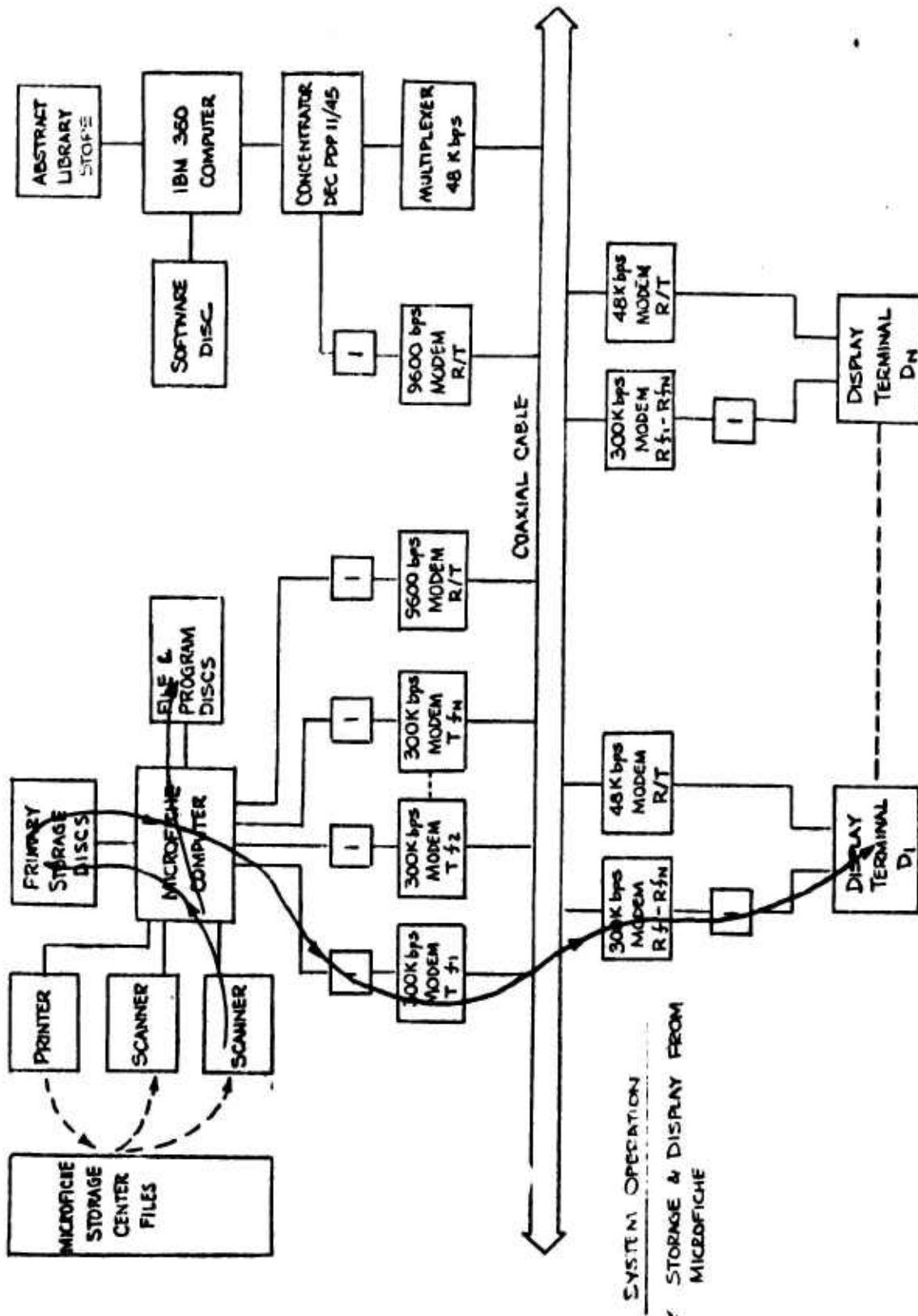

DATA FLOW - STORAGE AND DISPLAY FROM MICROFICHE

FIGURE 4-4

screen to be viewed by the analyst. The total process from the start of scan to complete display can be accomplished in about 11 seconds for the first image. Meanwhile, scanning continues until the complete microfiche card is stored on disc. A signal is then generated to notify the scanner operator that the scanning operation is finished and the scanner is available for a new input after the previous card is removed. The terminal viewer can now request any microfiche page in any sequence. Data will remain in storage until the viewer no longer needs it as evidenced either by an erase command from the terminal or expiration of a predetermined period.

The high speed transmission channel requires some discussion here. Six high-speed transmit-only modems are provided for image data transmission at the microfiche computer. Channels are dynamically allocated to the appropriate terminal under computer control. All six channels can be transmitting simultaneously. Each display terminal is supplied with a 300 kilobit/second receive only modem which can be tuned (during automatic channel allocation) to one of the six transmission frequencies.

4.1.4 IMAGE REQUEST FROM PRIMARY STORAGE DATA FLOW

The final step in the cycle is actually a repetition of previous actions. This is a request for subsequent pages on the stored microfiche. At this point, the user knows that data he desires is stored in the system on disc. As before, a message is originated at the display terminal and transmitted over the 48 kilobit/second channel to the concentrator. The sequence is shown in Figure 4-5. Again, the concentrator decodes the message preamble and routes it via the low speed 9600 baud channel to the microfiche

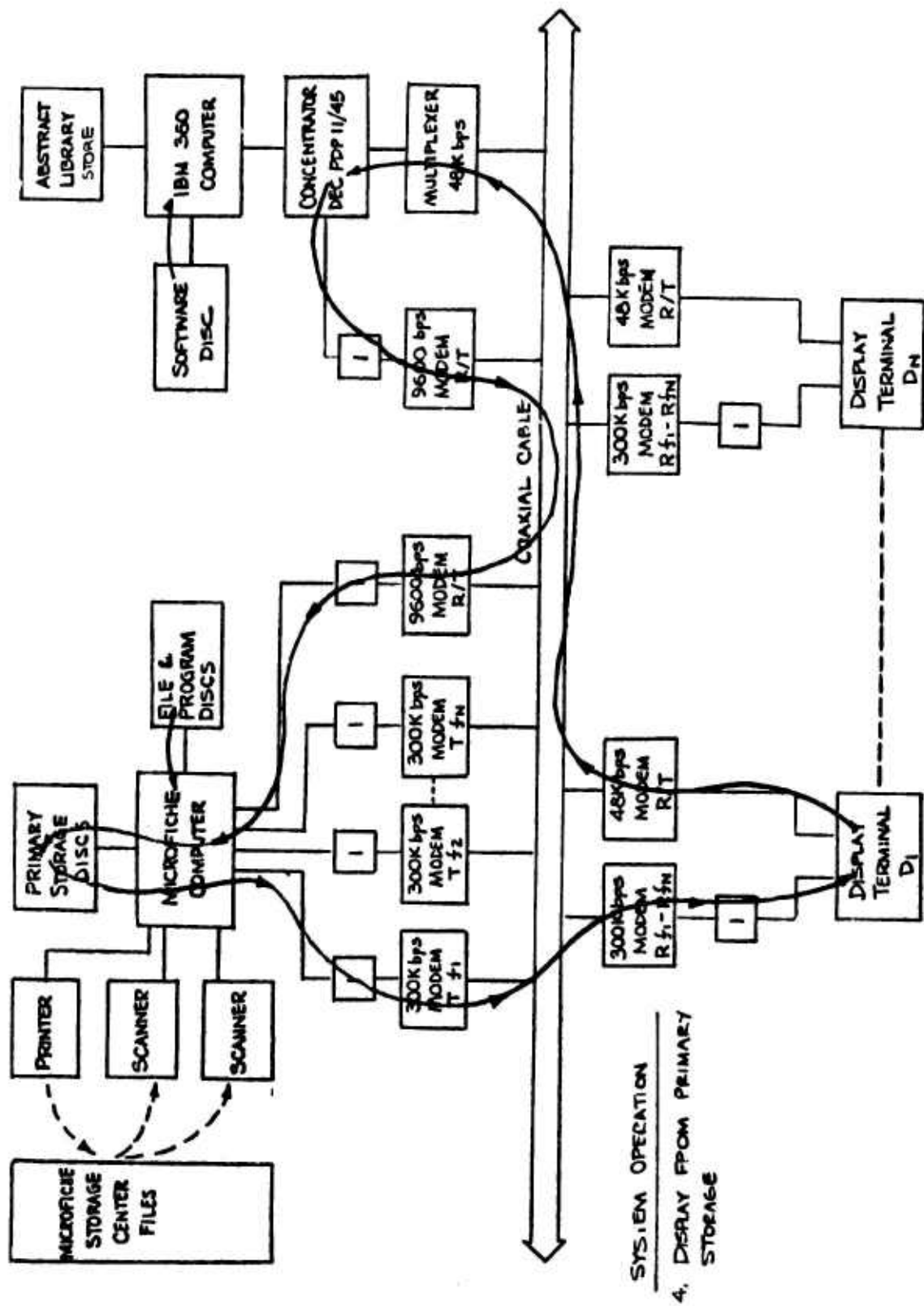

DATA FLOW - DISPLAY FROM PRIMARY STORAGE

FIGURE 4-5

processor. The processor further decodes the preamble, examines the index file to determine the data location, retrieves it from disc storage, and transmits the image data, using a 300 kilobit channel, to the display terminal. The demodulated data is then presented on the output screen for viewer evaluation. The user then continues in this mode of operation until he requires a new set of data, at which time another microfiche card request is entered. System reaction time to obtain images from primary store and to transmit an entire page is less than 7 seconds.

4.2 SYSTEM CAPABILITIES

The recommended Microfiche System has been configured to satisfy the following capabilities.

Functional Specifications

- a. Provides the capability of accessing microfiche documents and displaying pages on a remote terminal.
- b. Allows interactive dialogue via remote display keyboards with other FTD Information Systems.
- c. Provides 2:1 magnification zoom capability of any section of the microfiche page.
- d. System accommodates up to 100 remote terminals, 2 input microfiche scanners, and 6 microfiche image transmission channels.

Technical Specifications

- a. Primary storage computer accommodates 800 pages, or 40 active users (20 page average document size).
- b. Daily scanner throughput can be 10,000 pages without queuing delay.
- c. Scanning and storage time is less than 4.0 seconds per page.
- d. The transmission time from primary store is less than 7.0 seconds per page.

4.3 SYSTEM RESPONSE TIME

It is assumed that the Microfiche System work session is preceded by an interactive session with other information systems lasting from a few minutes to several hours in order to obtain abstracts and microfiche numbers of interest. Once the work session starts on the Microfiche System, the response times shown in Table 4-1 for the various activities can be considered as typical.

Because there are two scanners, both the first and second user on the system will receive their first page in about 30.5 seconds (this is highly dependent on typing time and manual loading of the scanner). Subsequent pages which are in primary storage can be displayed within 7 seconds (not considering typing time which may take another second). When three or more analysts request new microfiche documents within the scanner service time, a queue will develop at the scanner and waiting time will increase. Queues can also develop during transmission of the data when the 6 transmission channels are all being used simultaneously.

TABLE 4-1
SYSTEM RESPONSE TIME

MICROFICHE REQUEST	- TYPING TIME	5 SEC
	- SYSTEM RESPONSE	0.8 SEC
MANUAL SEARCH AND LOADING OF SCANNER		15 SEC to 30 SEC
SCANNING AND STORAGE		3.7 SEC FIRST PAGE
TRANSMISSION		6.0 SEC
		<hr/> <hr/> 30.5 SECS

4.4 QUEUING ANALYSIS

The system performance analysis cannot be considered complete without conducting a queuing analysis to determine if the system, as designed, is capable of handling the expected inputs. The analysis will quickly show if congestion or overloading will occur.

Queues can occur at two places in the Microfiche System: at the input scanner when several microfiche are requested within the scanner service period and at the transmission channel when all of the channels are simultaneously used. Both of these queues are examined. The mean number of users in each queue, average waiting times, and maximum waiting times are determined for a range of facility utilization factors.

4.4.1 BASIC QUEUING ANALYSIS METHODOLOGY

The queuing analysis was performed using the methods outlined in "Systems Analysis for Data Transmission" by James Martin, published by Prentice-Hall, Inc., in conjunction with parametric charts reprinted with the publisher's permission.

Since curves representing the basic queuing relationships are readily available, only the parameters needed to use them properly will be discussed.

The facility utilization factor, which is a measure of system loading used as the abscissa on the parametric queuing analysis charts, is defined as

$$\rho = \frac{\text{The time the facility is occupied}}{\text{The time available}} = \frac{E(n)E(t_s)}{M} \quad (4-1)$$

where

n = number of arrivals

t_s = service time of an item

$E(n)$ = mean arrival time of an item

$E(t_s)$ = mean service time of an item

M = number of channels being serviced.

By using this factor with the parametric queuing curves, it is possible to determine both the mean number of items in a queue $E(q)$ and the mean time spent by an item in the queue $E(tq)$. These calculations are based on the assumption that the service times are exponentially distributed. In practice, this is not normally the case so that this is regarded as a worst case evaluation.

Another useful parameter is the probability of waiting for longer than some arbitrary times, t .

This is given by

$$\text{Prob}(t_w > t) = B^{-M(1-\rho)t/E(t_s)} \quad (4-2)$$

where,

t_w = time an item waits to be serviced

B = probability of all servers being busy at a given instant

The parameter B may be obtained from Table 4-2.

4.4.2 INPUT SCANNER QUEUE

The schematic diagram of the queue at the input scanner, Figure 4-6, illustrates how the facility utilization factor of each of two scanners is obtained by considering the mean number of microfiche arrivals per second and the mean service time. Figure 4-7 gives the facility utilization factors for a number of different microfiche arrival rates, so that the effect of increasing $E(n)$ can be observed. As shown in row 2 of Figure 4-7 an estimate of a reasonable average input was assumed to be 320 microfiche per (8 hour) day, or $E(n) = 0.011$ microfiche/second. This corresponds to a facility utilization factor of 0.408 which represents a light system load. In addition, the last column shows the waiting time which will not be exceeded by 95% of the users. It should be noted that reliable statistics defining anticipated system usage (and corresponding arrival rates) could not be obtained from FTD so that the value $E(n)$ represents an estimate based on the best available information.

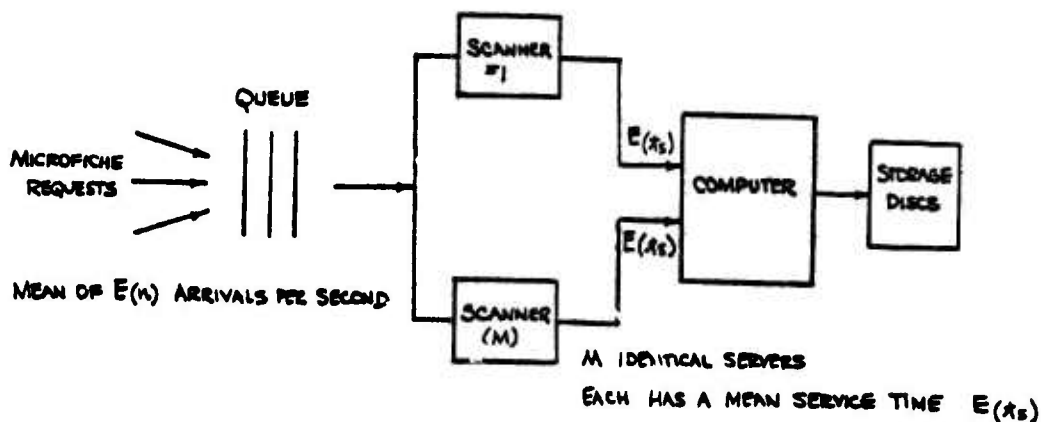

FACILITY UTILIZATION OF EACH SCANNER

$$\rho = \frac{E(n) E(x_s)}{M}$$

QUEUE AT THE INPUT SCANNER

FIGURE 4-6

ANALYSTS USING SYSTEM	DOCUMENTS/ANALYST	$E(n)$ MEAN NO ITEMS SERVED	SCANNERS (M)	SCANNER RATE	$E(x_s)$ SERVICE TIME	FACILITY UTILIZATION $\rho = \frac{E(n)E(x_s)}{M}$	5% PROB. $E(TW) > T$
10% = 40	4	$\frac{40 \times 4}{8760 \times 60} = .0055$ ITEMS/SEC	2	2 Mbps	20 (MIPS) 3.17573.5 SECS	$\frac{.0055 \times 73.5}{2} = 0.204$	19.5 Sec
20% = 80	4	.01112/sec	2	2 Mbps	73.5 SECS	0.408	96.8 Sec
20% = 80	8	.02224/sec	2	2 Mbps	73.5 SECS	0.816	537.6 Sec
25% = 100	8	.0278	2	2 Mbps	73.5 SECS	1.02	∞

ASSUME: TOTAL OF 400 ANALYSTS
100 TERMINALS MAX

INPUT SCANNER QUEUING PARAMETERS

FIGURE 4-7

TABLE 4-2

VALUES OF PROBABILITY THAT ALL M SERVERS ARE BUSY

Facility Utilization ρ	M=1	M=2	M=3	M=4	M=5	M=6	M=7	M=8	M=9	M=10	M=11
0.00	0.000	0.000	0.000	0.000	0.000	0.000	0.000	0.000	0.000	0.000	0.000
0.02	0.020	0.001	0.000	0.000	0.000	0.000	0.000	0.000	0.000	0.000	0.000
0.04	0.040	0.003	0.000	0.000	0.000	0.000	0.000	0.000	0.000	0.000	0.000
0.06	0.060	0.007	0.001	0.000	0.000	0.000	0.000	0.000	0.000	0.000	0.000
0.08	0.080	0.012	0.002	0.000	0.000	0.000	0.000	0.000	0.000	0.000	0.000
0.10	0.100	0.018	0.004	0.001	0.000	0.000	0.000	0.000	0.000	0.000	0.000
0.12	0.120	0.026	0.006	0.002	0.000	0.000	0.000	0.000	0.000	0.000	0.000
0.14	0.140	0.034	0.009	0.003	0.001	0.000	0.000	0.000	0.000	0.000	0.000
0.16	0.160	0.044	0.014	0.004	0.001	0.000	0.000	0.000	0.000	0.000	0.000
0.18	0.180	0.055	0.019	0.007	0.002	0.001	0.000	0.000	0.000	0.000	0.000
0.20	0.200	0.067	0.025	0.010	0.004	0.002	0.001	0.000	0.000	0.000	0.000
0.22	0.220	0.079	0.032	0.013	0.006	0.003	0.001	0.001	0.000	0.000	0.000
0.24	0.240	0.093	0.040	0.018	0.008	0.004	0.002	0.001	0.000	0.000	0.000
0.26	0.260	0.107	0.049	0.023	0.011	0.006	0.003	0.001	0.001	0.000	0.000
0.28	0.280	0.122	0.059	0.030	0.015	0.008	0.004	0.002	0.001	0.001	0.000
0.30	0.300	0.138	0.070	0.037	0.020	0.011	0.006	0.004	0.002	0.001	0.001
0.32	0.320	0.155	0.082	0.046	0.026	0.015	0.009	0.005	0.003	0.002	0.001
0.34	0.340	0.173	0.095	0.055	0.033	0.020	0.012	0.007	0.005	0.003	0.002
0.36	0.360	0.191	0.110	0.066	0.040	0.025	0.016	0.010	0.007	0.004	0.003
0.38	0.380	0.209	0.125	0.078	0.049	0.032	0.021	0.014	0.009	0.006	0.004
0.40	0.400	0.229	0.141	0.091	0.060	0.040	0.027	0.018	0.013	0.009	0.006
0.42	0.420	0.248	0.158	0.105	0.071	0.049	0.034	0.024	0.017	0.012	0.009
0.44	0.440	0.269	0.177	0.120	0.084	0.059	0.043	0.031	0.022	0.016	0.012
0.46	0.460	0.290	0.196	0.137	0.098	0.071	0.052	0.039	0.029	0.022	0.016
0.48	0.480	0.311	0.216	0.155	0.114	0.084	0.064	0.048	0.037	0.028	0.022
0.50	0.500	0.333	0.237	0.174	0.130	0.099	0.076	0.059	0.046	0.036	0.028
0.52	0.520	0.356	0.259	0.194	0.149	0.115	0.090	0.072	0.057	0.046	0.037
0.54	0.540	0.379	0.281	0.216	0.168	0.133	0.106	0.086	0.069	0.057	0.046
0.56	0.560	0.402	0.305	0.238	0.190	0.153	0.124	0.102	0.084	0.069	0.058
0.58	0.580	0.426	0.330	0.262	0.212	0.174	0.144	0.120	0.100	0.084	0.071
0.60	0.600	0.450	0.355	0.287	0.236	0.197	0.165	0.140	0.119	0.101	0.087
0.62	0.620	0.475	0.381	0.313	0.262	0.221	0.188	0.161	0.139	0.120	0.105
0.64	0.640	0.500	0.408	0.340	0.289	0.247	0.213	0.185	0.162	0.142	0.125
0.66	0.660	0.525	0.435	0.369	0.317	0.275	0.241	0.212	0.187	0.166	0.148
0.68	0.680	0.550	0.463	0.398	0.347	0.305	0.270	0.240	0.215	0.193	0.173
0.70	0.700	0.576	0.492	0.429	0.378	0.336	0.301	0.271	0.245	0.222	0.202
0.72	0.720	0.603	0.522	0.460	0.410	0.369	0.334	0.303	0.277	0.254	0.233
0.74	0.740	0.629	0.552	0.493	0.444	0.404	0.369	0.339	0.312	0.288	0.267
0.76	0.760	0.656	0.583	0.526	0.480	0.440	0.406	0.376	0.349	0.326	0.304
0.78	0.780	0.684	0.615	0.561	0.516	0.478	0.445	0.416	0.390	0.366	0.345
0.80	0.800	0.711	0.647	0.596	0.554	0.518	0.486	0.458	0.432	0.409	0.388
0.82	0.820	0.738	0.680	0.633	0.593	0.559	0.529	0.502	0.478	0.455	0.435
0.84	0.840	0.767	0.713	0.670	0.634	0.602	0.574	0.548	0.525	0.504	0.485
0.86	0.860	0.795	0.747	0.709	0.675	0.646	0.621	0.597	0.576	0.556	0.538
0.88	0.880	0.824	0.782	0.748	0.718	0.693	0.669	0.648	0.629	0.611	0.594
0.90	0.900	0.853	0.817	0.788	0.762	0.740	0.720	0.702	0.687	0.669	0.654
0.92	0.920	0.882	0.853	0.829	0.808	0.789	0.772	0.757	0.743	0.729	0.717
0.94	0.940	0.911	0.889	0.870	0.854	0.840	0.827	0.815	0.803	0.793	0.783
0.96	0.960	0.940	0.925	0.913	0.902	0.892	0.883	0.874	0.866	0.859	0.852
0.98	0.980	0.970	0.962	0.956	0.950	0.945	0.940	0.936	0.932	0.928	0.924

2 SCANNERS AT 2 MBPE DATA RATE
 BASED ON AVERAGE DOCUMENT OF 20 PAGES

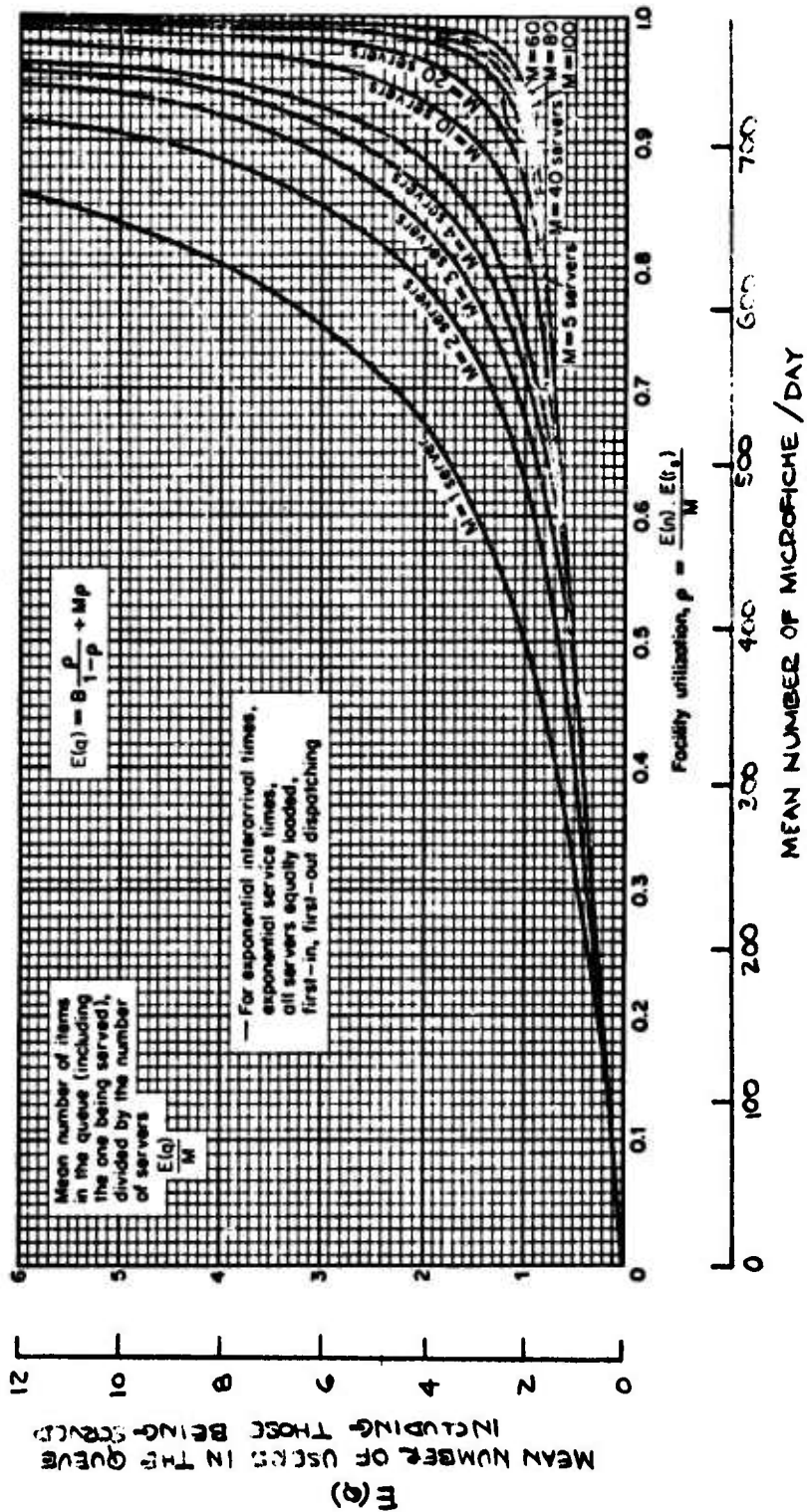

QUEUEING ANALYSIS AT INPUT SCANNER -
 MEAN NUMBER OF USERS IN THE QUEUE

FIGURE 4-8

James Martin, SYSTEMS ANALYSIS, (C) 1972, pp.462. Reprinted by permission of Prentice-Hall, Inc., Englewood Cliffs, New Jersey.

The mean number of users in the scanner queue for different facility utilization values is shown by the parametric scanner queuing chart in Figure 4.8. Note that at a facility utilization of 0.41, for two input scanners (2 servers), the mean number of users in the queue is about one, so that no one has to wait to be served. Even at a utilization factor of 0.82, which represents an input of 640 microfiche per day, only two people on the average are in the scanner queue (however, they are being served). It should be noted that at a facility utilization of 0.64, the two users in the queue are being served. This implies that 500 microfiche per day, or 10,000 pages, can be handled by the scanners without a queuing delay.

Figure 4-9 illustrates the mean waiting time before being served by the input scanner for different facility utilization factors. At $\rho = 0.41$, there is no waiting time. At a facility utilization of 0.82, however, there will be an average waiting time of about 140 seconds. This high system loading is very unlikely and may rarely occur.

4.4.3 TRANSMISSION CHANNEL QUEUE

The queue that may develop at the output transmission channel is shown schematically in Figure 4-10. The facility utilization of each of the six transmission channels is determined by knowing the mean number of pages per second requested from the computer storage and the mean service time of the transmission link. Various facility utilization factors for each transmission

James Martin, SYSTEMS ANALYSIS, (C) 1972, pp.463. Reprinted by permission of Prentice-Hall, Inc., Englewood Cliffs, New Jersey. **2 SONNERS AT 2 Mbps DATA RATE BASED ON AVERAGE DOCUMENT OF 20 PAGES**

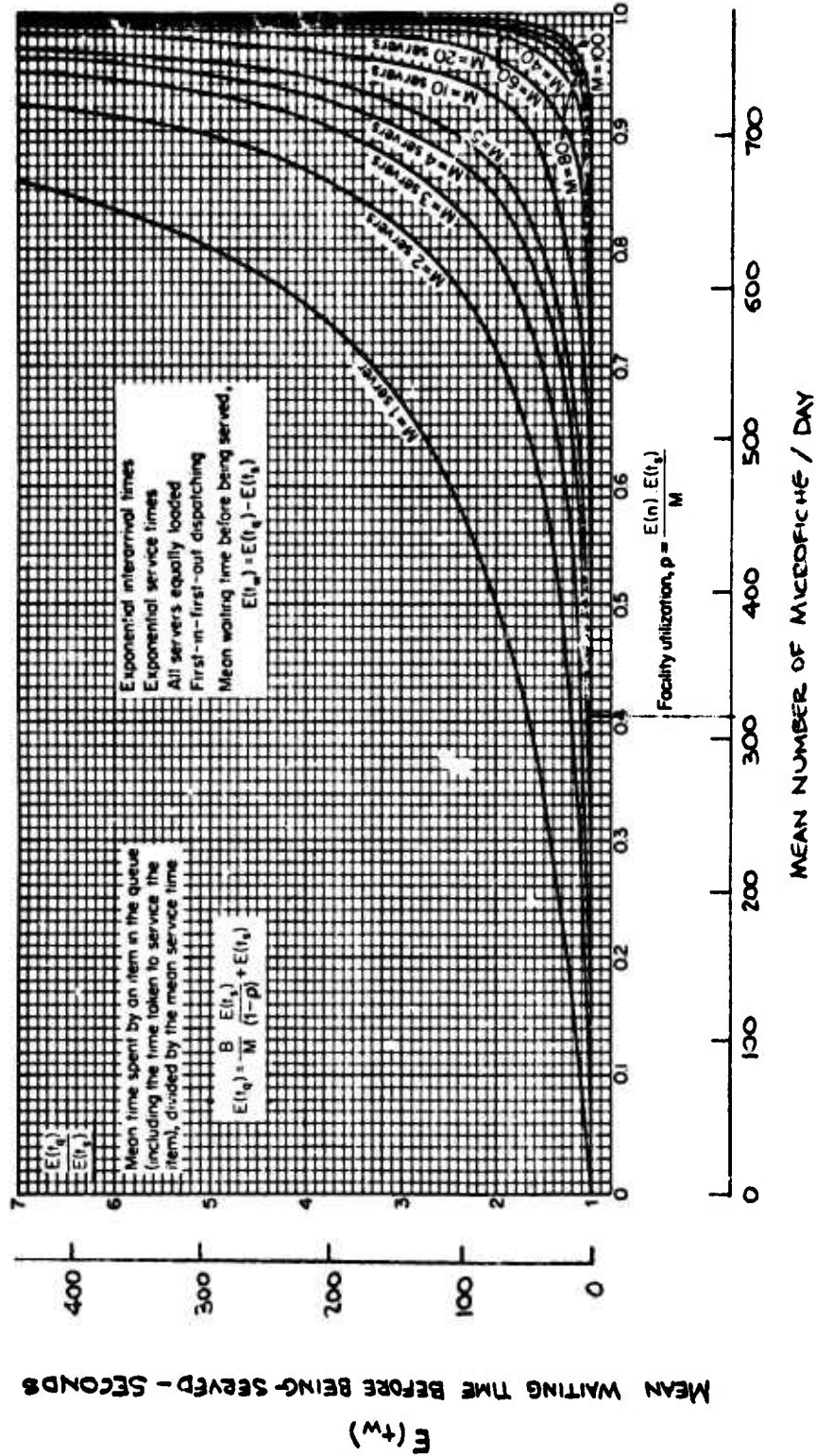

QUEUEING ANALYSIS AT INPUT SCANNER -
 MEAN QUEUEING TIME
 FIGURE 4-9

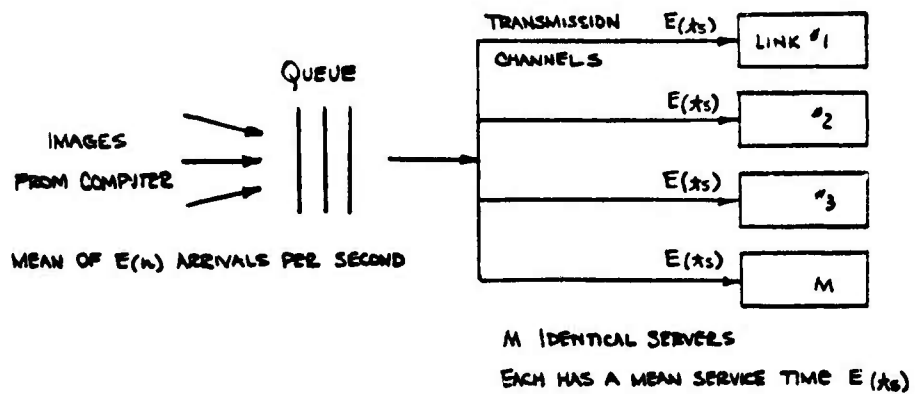

FACILITY UTILIZATION OF EACH CHANNEL

$$\rho = \frac{E(n) E(s)}{M}$$

QUEUE AT THE TRANSMISSION CHANNEL

FIGURE 4-10

ANALYSTS AT TERMINALS	MEAN TIME BETWEEN PAGES	$E(n)$ MEAN NO. PAGES PER SECOND	M TRANSMISSION CHANNELS	$E(s)$ SERVICE TIME	$\rho = \frac{E(n) E(s)}{M}$ FACILITY UTILIZATION	5% PROB $E(T_w) > T$
10% = 40	2 MINUTES	$\frac{40 \times 1 \text{ PAGE}}{120 \text{ SECONDS}} = .33$	6	6.5 SEC	$\frac{0.33 \times 6.5}{6} = 0.357$	-
10% = 40	1 MINUTE	$\frac{40}{60} = .67$	6	6.5 SEC	0.726	8.1 SEC
10% = 40	0.75 MINUTE	$\frac{40 \times 1}{45 \text{ SEC}} = .89$	6	6.5 SEC	0.964	87.0 SEC
25% = 100	2 MINUTES	$\frac{100 \times 1 \text{ PAGE}}{120 \text{ SEC}} = .83$	6	6.5 SEC	0.899	28.9 SEC
5% = 20	30 SECONDS	$\frac{20 \times 1 \text{ PAGE}}{30 \text{ SEC}} = .67$	6	6.5 SEC	0.726	8.1 SEC

ASSUME: TOTAL OF 400 ANALYSTS
100 TERMINALS MAX.

TRANSMISSION CHANNEL QUEUING PARAMETERS

FIGURE 4-11

James Martin, SYSTEMS ANALYSIS, (C) 1972, pp.462. Reprinted by permission of Prentice-Hall, Inc., Englewood Cliffs, New Jersey.

2 SCANNERS AT 2 Mbps DATA RATE

BASED ON AVERAGE DOCUMENT OF 20 PAGES

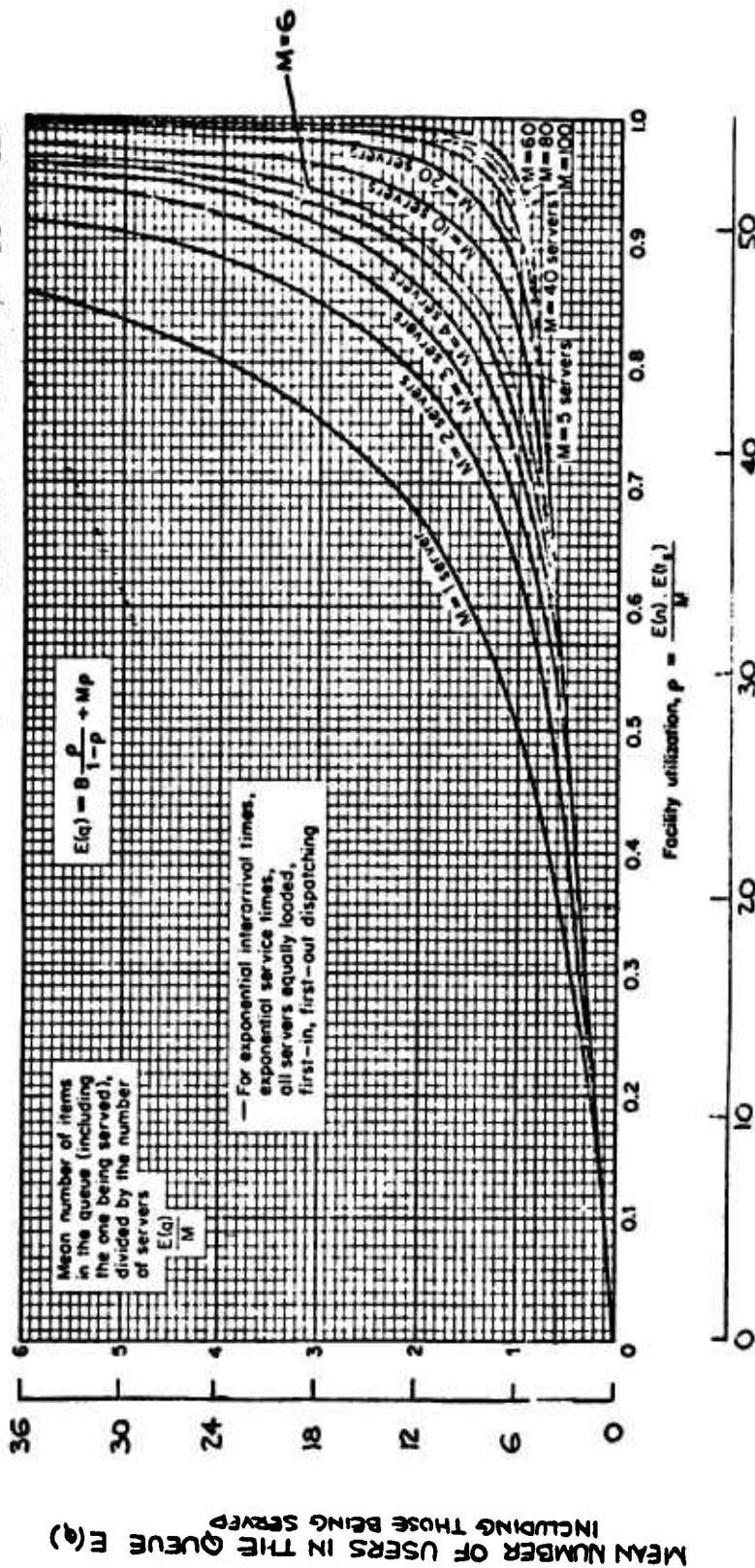

MEAN NUMBER OF PAGES REQUESTED PER MINUTE FROM PRIMARY STORAGE

QUEUEING ANALYSIS AT TRANSMISSION CHANNELS
MEAN NUMBER OF USERS IN THE QUEUE

FIGURE 4-12

channel are calculated in Figure 4-11 to illustrate the effect of changing the interarrival rate.

For a reasonable interarrival rate of 0.33 pages/second, the facility utilization is only 0.35. The parametric queuing analysis chart for the transmission channels, given in Figure 4-12, shows that no queue will develop with this system load (use the curve for 6 servers). In fact, the facility utilization can increase to 0.76 before the mean number of users exceeds the number of transmission channels. The mean number of pages requested per minute corresponding to this facility utilization is over 40 pages per minute.

The mean waiting time before being served by the transmission channel is illustrated in Figure 4-13. This parametric queuing chart shows that even at a facility utilization factor of 0.76, which is equivalent to over 40 users each requesting pages at one minute intervals, the users in the queue will have a wait of only 3 seconds.

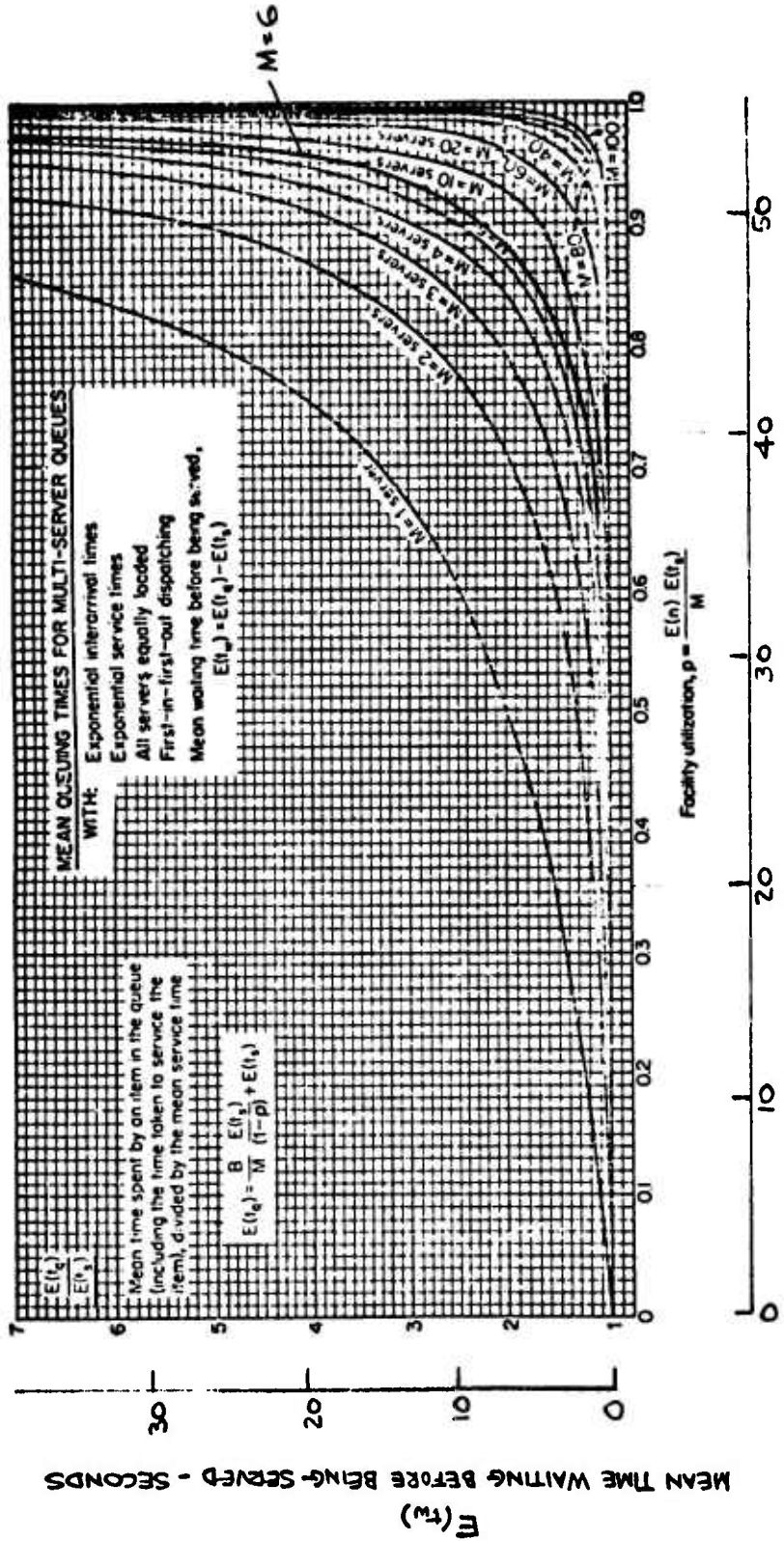

4.5 SYSTEM COMPONENT SPECIFICATIONS

The major system components are fully described in this section. Functional and technical specifications for each component are established in the discussion.

4.5.1 COMMUNICATION LINK

The communication link for the Microfiche System will be the VIDEODATA System currently being installed at FTD, by Interactive Systems, Inc., of Ann Arbor, Michigan. VIDEODATA is a radio frequency (RF) transmission system capable of distributing audio, video, or digital data information from a central location to and/or from remote stations on a single cable network. The system is composed of a single solid coaxial cable, amplifiers, directional couplers, and splitters. Information is transmitted by modulating a high frequency carrier with data at the sending location and demodulating the signal at the receiving point. Two modes of operation are available over the same transmission medium; time-division multiplexing or frequency-division multiplexing. Both methods are used in the microfiche system to achieve the desired results.

4.5.1.1 Cable Network Characteristics. Use of a simple coaxial cable eliminates the need for individual twisted pairs of wires to each location. In addition, due to its construction, the cable can be installed without conduit. It is free from electronic interference so that shielding is not required. Also, any additions in equipment do not require extra wiring or rewiring.

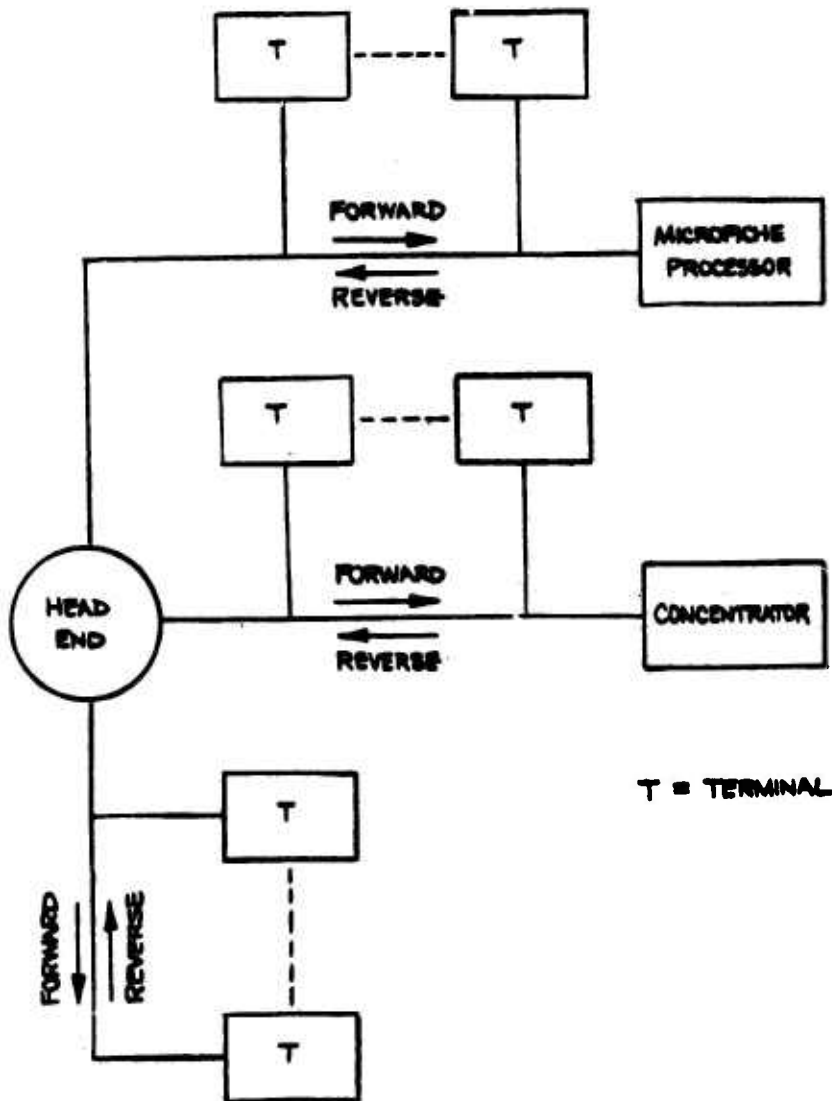

NETWORK CONFIGURATION

FIGURE 4-14

The cable itself is composed of a solid aluminum outer conductor and an inner concentric conductor which is typically copper-clad aluminum; both conductors being separated by a dielectric material which may be either polyethylene or polystyrene. The outer diameter of the cable is normally 0.412 inch or 0.500 inch. Transmission may take place over a bandwidth covering 5 megahertz to 300 megahertz. A noise shield (both in and out of the cable) is provided by the outer conductor. In addition, the thickness of this solid aluminum sheath provides a structure rigid enough so that the cable may be installed without conduit within a building. Besides the cable, amplifiers are required to regenerate the signal approximately every 2000 feet.

4.5.1.2 Bandwidth Allocations. As previously stated, the cable has a bandwidth of 5MHz (megahertz) to 300 MHz. The two-way broadband network has, by its design, an implicit signal direction. Each direction is allotted a portion of the available bandwidth. For example, using a mid-band split configuration, approximately 150 MHz to 300 MHz is allocated for the forward direction and 5 MHz to 150 MHz for the reverse direction. Also, a dead band is assigned between 116 MHz and 159 MHz which provides adequate separation between the forward and reverse channels. Directional control of these frequency groups is accomplished by means of appropriate filters in the amplifiers and directional taps used on the system. Any attempt of a signal to pass in an incorrect direction will be blocked at the amplifier.

4.5.1.3 Network Configuration. Figure 4-14 illustrates a possible layout of the cable network. Normally, it consists of remote locations and

a head end. Cable legs emanating from the head end are distributed along main thoroughfares. Feeder cables are then installed to link up remote user areas. Branches are terminated at the farthest user area and are not returned to the head end.

Typically, a computer is located at the head end. However, such a decision depends heavily on the geographical location of the various equipments within a building relative to the cable network paths. Forward transmissions are made from the head end to remote points and reverse transmissions from remote locations to the head end. As an example, using Figure 4-14, consider a message to be sent from the microfiche processor to a terminal on one of the network legs. Transmission would first take place on a reverse channel until it reached the head end. At this point, a remodulator would transfer the data from a reverse carrier frequency to a forward carrier frequency and thus transmit the message in a forward direction on all three network legs where it would be received by one or more terminals. It is immaterial whether the ultimate destination or terminal is on the same leg as the message origin for this type of system, as the final address for any particular message could be in any area of the network. Therefore, the same action takes place on all data transmissions. A separate remodulator will be required for each message channel (or forward and reverse carrier frequency pair) required in the system. For the Microfiche System a maximum of eight remodulators are required (depending on the head end location), 6 for the high speed channels, one for the 9600 baud line and one for the 48 Kbps multiplexed network.

4.5.1.4 Modems. The term modem is encountered in the data transmission field and is an abbreviation for modulator-demodulator. As applied to this system, a modem is required to accept digital data, modulate a high frequency carrier with that data, and transmit the information over the coaxial cable. It must also accept a different return modulated high frequency carrier, demodulate the data on the carrier and present it in a digital mode to the appropriate device.

Although these units will always be referred to as modems, they can and will sometimes be either modulators or demodulators only, i.e., either send or receive devices. In such cases, they will be called transmit only or receive only modems. A brief discussion of the types to be used in this system is given in the following paragraphs.

4.5.1.4.1 Modem - 9600 Baud. These relatively low speed devices are transmit-receive modems used for communication between the microfiche processor and the FTD concentrator. Only one pair is required in the system as the amount of data passing between the two processors is insignificant compared to the overall system rate.

The term baud refers to the shortest signal element in a character. For example, a character may be composed of 7 bauds, but only 5 data bits. The remaining two are start-stop elements as used in an asynchronous transmission system.

ISI 300 SERIES
FULL DUPLEX OPERATION

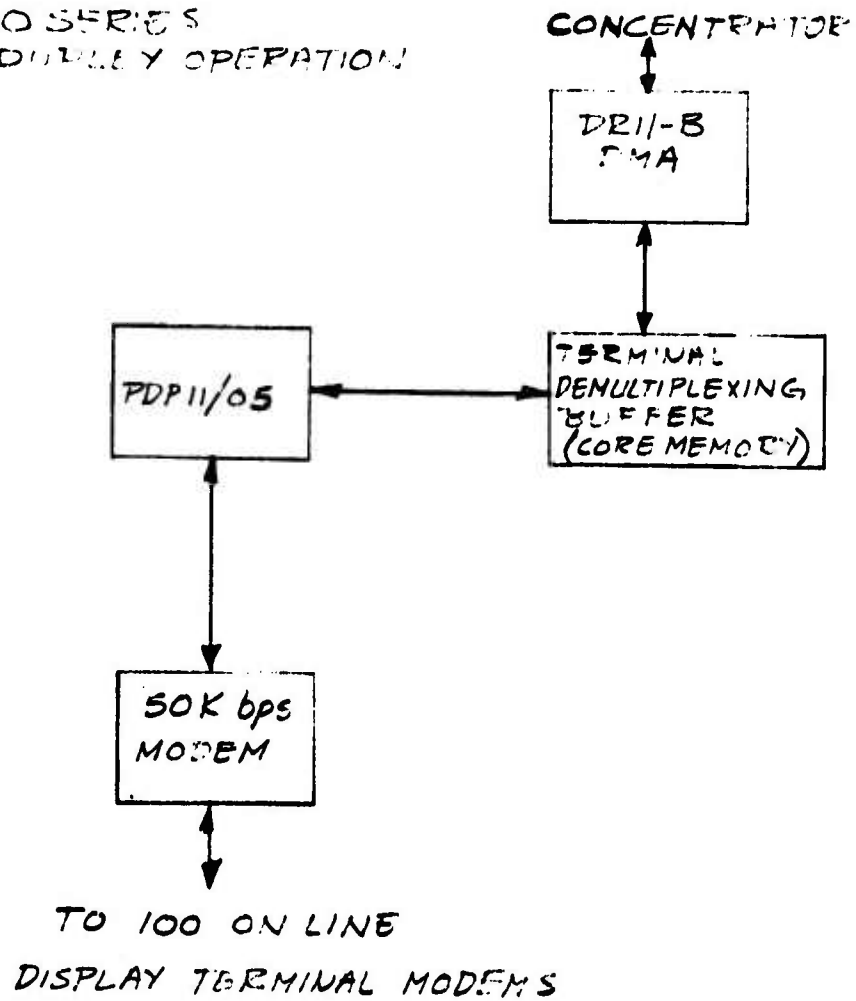

48 Kbit/SECOND MULTIPLEXER

FIGURE 4-15

4.5.1.4.2 Modem - 48 Kbps. These units are also transmit-receive modems and are used between the display terminal and the concentrator. They operate at 48 kilobits/second and are used in a time-division multiplexing scheme described in the following section. These channels are used when the terminal user is interrogating the abstract library computer, requesting data from the microfiche computer, or receiving information and/or instructions from the concentrator. One modem will be required at each terminal.

4.5.1.4.3 Multiplexer - 48 Kbps. This unit will be located at the concentrator and operates at 48 kilobits/second. It communicates with all the display terminal 48 kbit/second modems using a single high frequency carrier (to conserve cable bandwidth) and operating in the time-division multiplex mode. This is accomplished by interrogating each terminal in turn with an address code unique to a given terminal. When the desired terminal responds, it may either receive or transmit one character or no action may take place depending on the situation at that given moment in time. The multiplexer works isochronously so that each terminal receives equal attention. For example, if 100 terminals were in the system, any one or all could either receive or transmit data at a rate of approximately 36 characters/second. This is more than sufficient to handle the normal input from a display keyboard.

The multiplexer shown in Figure 4-15 contains a small processor with core memory to handle all necessary preprogrammed operations. The processor will control the multiplexing and generate the required protocol signals. Message units from each terminal will be accumulated in the memory until complete messages are assembled, at which time the total message will be sent to the concentrator for further processing.

The advantages of using a multiplexer in this instance are twofold. First is the previously mentioned saving in cable bandwidth. Second is the reduction in complexity and sheer amount of equipment involved in attaching 100 transmit-receive 48 kilobit modems to the concentrator. In addition, the concentrator is relieved of performing various software functions which are done in the processor portion of the multiplexer and as a consequence less concentrator memory is needed.

4.5.1.4.4 Modem - 300 Kbps Transmit Only. These modems operate at a high bit rate (300 kilobits/second) and are send only devices. Six of these units will be used to provide high speed output transmission channels for the microfiche processor. Each will operate on its own high frequency carrier. Connection to the processor will not be direct, but through an interface unit whose function is to format the output data properly and provide a serial stream of digital bits for the modem.

This type of modem cannot be used with abandon in a system as they account for a large amount of cable bandwidth. A single direction 300 kilobit/second modem occupies 1.2 megahertz of the available spectrum. A two-way device (using 2 separate forward and reverse carrier frequencies) uses 2.4 megahertz of the system bandwidth. Therefore, high speed modems must be used as sparingly as possible.

This high speed modem is not presently available, but is under development. Interactive Systems, Inc.⁽³⁾ has stated that the 300 kilobit modem will be ready for delivery during the first half of 1976.

(3) Private communication with Mr. George Benton of ISI.

4.5.1.4.5 Modem - 300 Kbit Receive Only. A modem of this type will be placed with each display terminal for the purpose of receiving high speed data (300 kilobits/second) on any one of the six high speed transmission channels from the microfiche computer. In order to accomplish this, which means that any one or more of the possible 100 terminals may receive information from any one of the six channels, the receive modems must be tunable or, in effect, frequency-division multiplexers. Again, it has been stated by Interactive Systems, Inc., that such devices will be available by the middle of 1976.

It is expected that a selectable frequency modem will be configured in a manner similar to that shown in Figure 4-16. In actual operation, a channel select command will be transmitted on the 48 kilobit channel from the concentrator and directed to the high speed frequency selectable modem. Internal logic circuitry will decode this signal and select one of the six crystal oscillators. The desired frequency is generated and mixed with the assigned incoming channel carrier frequency to demodulate the digital data. The demodulated data will then be serially given to the display terminal interface unit.

4.5.1.4.6 Remodulators. Remodulators are required to transfer modulated data from one carrier frequency to another. As described in Section 4.5.1.3, this is necessary when a message is transmitted from one leg on a reverse channel to a device on another leg via a forward channel. One remodulator is needed for each pair of forward and reverse channels in the cable network.

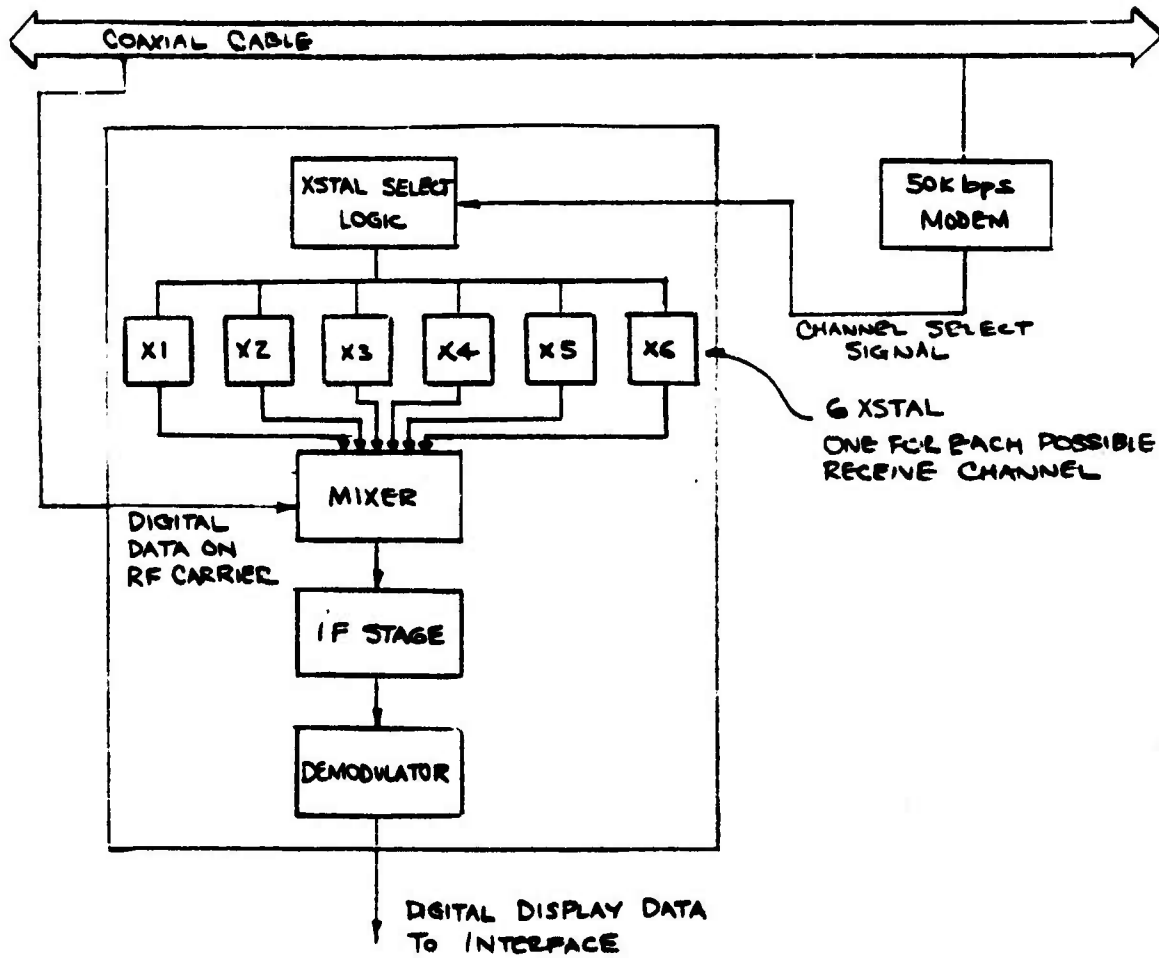

VARIABLE FREQUENCY MODEM - BLOCK DIAGRAM

FIGURE 4-16

4.5.1.5 Error Considerations. Most large data processing systems requiring extensive data transmission have some type of error checking scheme incorporating error detection and/or correction. It is the recommendation of this report that no error checking be attempted in the microfiche data retrieval system as it is unnecessary.

The primary reasons for using error checking in any system are when operating in a noisy environment or transmitting data which is especially sensitive to infrequent errors such as numerical information. Neither of these reasons apply to this system.

Image data, by its very nature, contains a large amount of redundancy and thus can accommodate many errors. In fact, it is realistic to assume that this particular system could easily tolerate an error per line or one error in 103 data bits without causing any misinformation to result. The coaxial cable system being used for data transmission provides a reasonably noise-free medium. Interactive Systems, Inc., (the cable supplier) indicates that previous installations have had error rates approaching 1 in 109. These were at lower data rates than those contemplated for the microfiche system and the error rate may be expected to increase. However, it would have to degrade by orders of magnitude before it became serious enough to cause concern.

If a simple error check were made such as a parity check, the result would be an increase in transmission time or display update. An error correction

scheme would require so much extra information to be sent that the increase in transmission time would be intolerable. Therefore, going back to a simple error detection method brings up the question of what to do in the event an error is found. If only error detection and not correction is employed, then the answer is to either retransmit the data or ignore the error. A small number of errors could cause excessive delays throughout the system if retransmission were adopted. Therefore, it is felt it is best to ignore the errors, eliminating the need for any error check. If an image is received which is badly garbled by some unusual onslaught of errors, then the terminal user has the option of requesting the display to be sent again. It follows, then, that an error check for this type of system would cause more problems than it would solve.

A simple system check which can be incorporated is to interrogate each 48 kilobit channel modem in turn and to monitor any acknowledge signal. This gives the basic information as to whether or not a terminal is still operative. Other problems which may arise can be resolved with the aid of diagnostic software routines.

4.5.2 COMPUTER CONFIGURATION

All processors and peripheral devices selected for this system are from Digital Equipment Corporation (DEC). It was elected to use DEC units for the following reasons:

- a. Both FTD and EPSCO personnel are thoroughly familiar with DEC systems;
- b. DEC equipment is currently in use at FTD and EPSCO Labs;
- c. DEC literature and information is readily available;
- d. DEC maintains an extensive service organization in case of equipment failure;
- e. The equipment enjoys a reputation for high reliability.

Essentially, the system makes use of two computers. One is the FTD PDP11/45 Concentrator, whose basic function is to maintain and control proper communication among all of the system components. The second is the microfiche computer which accepts digitized scanned microfiche data, stores it in memory, and transmits it on demand to the proper display terminal at high data rates.

4.5.2.1 Microfiche Computer. As shown in Figure 4-17, Microfiche Computer - Block Diagram, the Microfiche Computer consists of dual PDP11/40 processors, each with its own particular peripheral devices. Two processors are required in order to fulfill the system requirements in terms of storage capacity, speed of operation and user accessibility. (Use of a larger computer, such as a PDP11/70, would result in an overkill situation - its speed and memory capacity are not required -

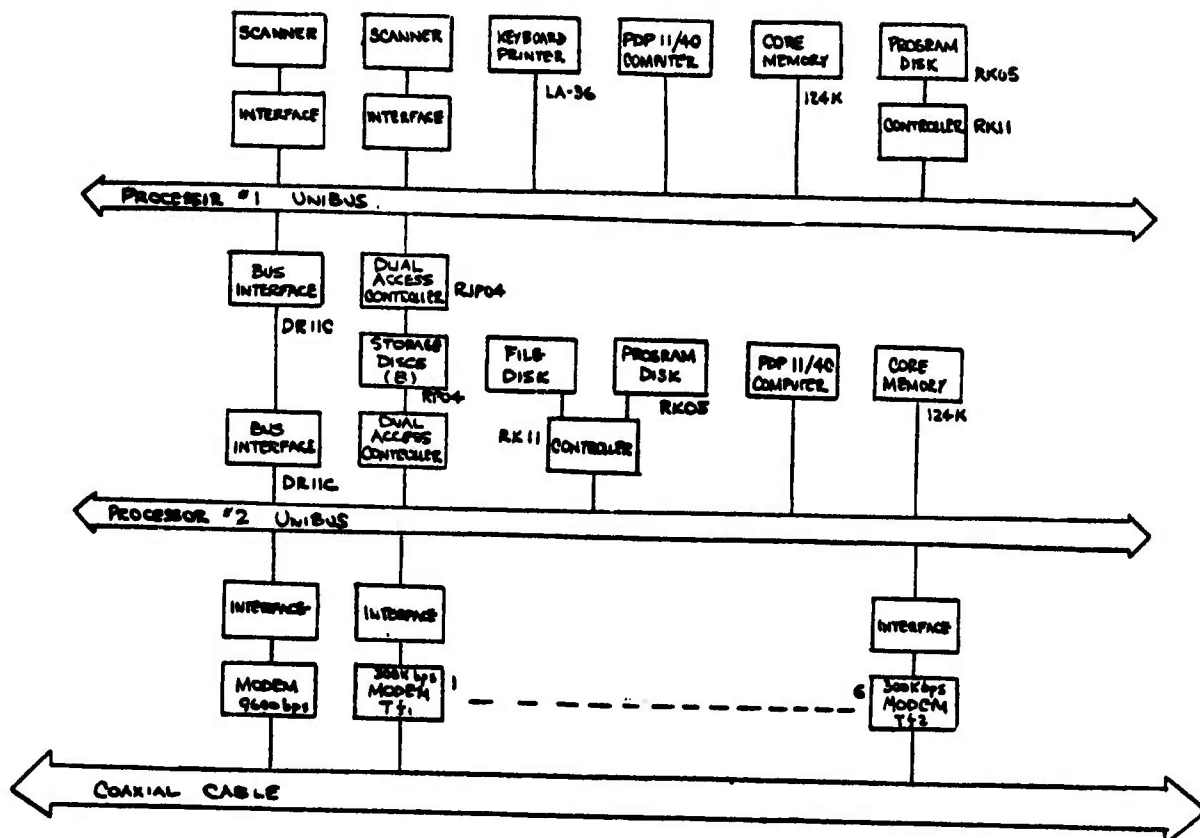

COMPUTER - BLOCK DIAGRAM

FIGURE 4-17

and also excessive cost). One processor is referred to as the input processor and the other as the output processor. The function of the input processor is to accept digitized scanned microfiche data which has been properly formatted and store it on a magnetic disc for future reference by a system user. The output processor records the location of data, retrieves data on command, transmits data to an output display, communicates with the concentrator and sends instructions to the input processor.

4.5.2.2 Input Processor. The input processing unit consists of a number of devices connected to each other on a common transmission link called a Unibus (a DEC pseudonym for a multiwire communication channel connecting a group of devices in close proximity). Following are the items which comprise the input system:

- a. PDP11/40 computer - used for overall system control;
- b. Core memory - 124K word (16 bit word) memory for program and data storage;
- c. RK05 Disk and RK11 Controller - 1.5 megaword magnetic disk used to store required program;
- d. LA-36 Keyboard Printer - used to inform operator concerning required data and to input control information into system;
- e. Two data digitizing microfiche input scanners with data formatting interfaces for entering requested data into system;
- f. DR11C Bus Interface permits communication between the input and output processor.

The basic sequence of operations for the input processor is as follows:

- a. A request for a particular microfiche card is received from

the output processor via the DR11C bus interface and printed out on the LA-36 printer;

- a. The operator (in a manual load system) obtains the desired card and places it in the scanner unit;
- b. The operator enters required control information such as microfiche card identification number, scanner number, etc., into the system via the keyboard printer;
- c. A start switch is operated, and the scanner digitizes the information on the microfiche card;
- d. The data is formatted as required by the scanner interface, buffered in the core memory and transferred to magnetic disc storage;
- e. An indicator and/or audible alarm informs the operator when the operation is complete and the microfiche card is then returned to its original location.

When operating at maximum load, the processor must be capable of handling two simultaneous scanner inputs at 2 megabits/second each, and also output data to a storage disk at 6.4 megabits/second. Since the core memory is capable of running at better than 16 megabits/second, actual data handling occupies $\frac{10.4}{16} \times 100\% = 65\%$ of the available processing time. This allows 35% for program control, which is more than sufficient for this type of operation.

From the above, it can easily be seen that for a single processor to be required to handle two scanners, both input and output data from disk, and handle a number of output channels all simultaneously, would quickly result in an overload condition. For example, just trying to both enter and retrieve data from disk simultaneously requires 12.8 megabits/second of the

available 16 megabit/second rate, leaving only 3.2 megabits/second to handle both input scanners, output channels and program control; clearly a non-permissible situation. This, then, is the primary justification for the use of two processors. There are, in addition, other advantages which will become evident later in the discussion.

4.5.2.3 Output Processor. The items in the output system consist of the following:

- a. PDP11/40 computer - used for overall system control;
- b. Core memory - 124K word memory for program and data storage;
- c. RK05 Disk and RK11 Controller - 1.5 megabit magnetic disk used to store required programs;
- d. RK05 Disk - 1.5 megabit magnetic disk, sharing above Controller, used to record location of stored data;
- e. DR11C Bus Interface - permits communication between the input and output processor;
- f. 9600 Baud Modem - used for communication between output processor and concentrator;
- g. Six high speed (300K/bit) modem with interface for data reformatting used to transmit data to requesting terminal.
- h. RJPO4 Dual Port Disc Unit with controller and eight RPO4 storage discs for microfiche data storage.

The basic sequence of operations for the output processor is as follows:

- a. An initial request for data is received from the concentrator via the 9600 baud modem, and passed to the input processor through the DR11C;
- b. The output processor also informs the input processor where to store data on disk;
- c. After the data is stored, the processor retrieves data from the disk memory (Any page of a microfiche may be requested by

the user, but the first page is transmitted automatically immediately after it is stored.), buffers it in core, and designates a transmission channel for use.

- d. The channel designation is sent via the concentrator to the requesting display terminal.
- e. When step (4) is acknowledged, data is output to the correct channel, reformatted in the interface and transmitted at a 300 Kbit/second rate to the waiting terminal.

At maximum load, the processor takes data from the disk at 6.4 megabits/second and simultaneously operates six 300K/bit/second output channels. Again, with a 16 megabit/second memory, data handling occupies $\frac{8.2}{16} \times 100\% = 51.25\%$ of available processing time, leaving a more than sufficient amount for program control and inter-computer communication.

4.5.2.4 Microfiche Data Storage Microfiche digitized and formatted data is permanently stored (until an erase command is received allowing new data to be written in place of data no longer needed) on a dual port disk unit. This device contains a dual access controller which allows both input and output processors to simultaneously interact with a particular disk. The unit will contain a total of 8 disks, each capable of recording 44 million words. Thus, one processor can enter data on one disk while the other processor can be receiving data from one of the other seven disks. In addition, subsequent disks to be used can be located during the time active disks are in operation, lowering the disk access time considerably. For example, the average access time, including head location and rotational latency, is 36 milliseconds. The average rotational latency, once the head is located, is only 8 milliseconds. This, of course, permits a larger number of output channels to be serviced simultaneously. All in all, the unique capabilities of this device permit one processor to be dedicated to input scanning operation while the second processor may be concerned solely with output problems.

Each page on a microfiche card is scanned at 2320 elements per line over 3000 lines for a total of 6.96 million bits or 435,000 words. Therefore, each disk holds approximately 100 pages of microfiche data with the total system containing 800 pages. At an average of 20 pages per microfiche, 40 users are able to be active in the system at any given time. During such a period, up to 6 terminals can be receiving data simultaneously, while the other 34 terminals have data displayed on their screens. As shown in the queuing analysis in this report, the system is quite capable of handling such a load.

4.5.2.5 Memory Organization. In order to facilitate the zoom display mode, an approach was conceived involving both hardware and software. Either approach singly is inadequate as it lengthens the time required to construct a display an undesirable amount. In both cases, the total amount of data required for high resolution zoom is stored on disk. Attempting to sort out a desired window of data for the zoom mode by software requires a substantial increase in core memory as well as additional processing time. This is due to the fact that all of the data must be read from disk and stored in core where it is operated on by a window selection program. That is, the data cannot be sorted out on the fly as it comes off the disk, either in the zoom mode or in the normal mode where only one quarter of the total data is used. Alternatively, all of the data could be transmitted to the display where simple circuitry employed in conjunction with the display sweep control circuits would easily edit out the undesired data. However, this would increase the data transmission time by a factor of four which is, of course, unacceptable.

The selected approach is to format the data for ease of manipulation with hardware before the input computer receives it, then organizing it correctly in core for subsequent storage on disk. Software programs then remove the data in the proper order as required for zoom or normal operation. Finally, the data is properly recombined by hardware after being received from the output computer and transmitted to the correct terminal.

4.5.2.5.1 Core Data Format. In order to provide for relatively simple data processing, the scanned data is organized into three groups by means of hardware and then stored in three core memory blocks. One group consists of all even lines and all elements within those lines. A second group has odd lines and all odd elements within those lines. The third group contains odd lines with all even elements. This last group of data is used to provide the information for a normal display, i.e., a picture with resolution of 1500 lines and 1160 elements per line.

4.5.2.5.2 Disk Data Format. As the data is transferred from core memory to disk, it is organized in groups of 3 records each. The first record of each group contains the data for odd lines, odd elements; the second record contains odd lines, even elements; and the third record has even lines, all elements. Now it is a simple matter to retrieve every third record for a normal display or to obtain every record for a zoom picture. This is done under program control given the proper command signal and cursor location (for zoom data) from the requesting terminal unit.

4.5.2.5.3 Input Processor Core Allocation. Figure 4-18, Computer Core Allocation, illustrates the manner in which the core memory is organized for data handling. The total amount of core available in the input processor is 124K words where a word is composed of 16 bits. 16K of core is reserved for program control with the remaining 108K of core divided for use between the two input scanners. Blocks of core are then set aside for particular sets of data associated with each scanner to act as buffers before permanent storage on a magnetic disk. Block sizes of 6,750 words are assigned for storing odd lines, odd elements and odd lines, even elements. A block of 13,500 words is used for storing even lines with all elements included. Each of these blocks is then double buffered as shown in the diagram to provide the ability to have the system operate in an asynchronous mode. An identical group of buffers is assigned for the second scanner which then accounts for a total of 108K words of core.

4.5.2.5.4 Output Processor Core Allocation. Again, refer to Figure 4-18, Computer Core Allocation. 16K of core is set aside for program control and the remaining 108K of core divided among six output channels. Blocks of core are provided to accept data in the same manner as it was presented to the input processor. Thus, associated with each output channel are block sizes of 2,250 words for storing odd lines, odd elements, and odd lines, even elements. In addition, a block of 4,500 words is provided for storing even lines and all elements. As in the case of the input processor, each core block is double buffered. An identical group of buffers is used for each of the six output channels taking up a total of 108K words of core.

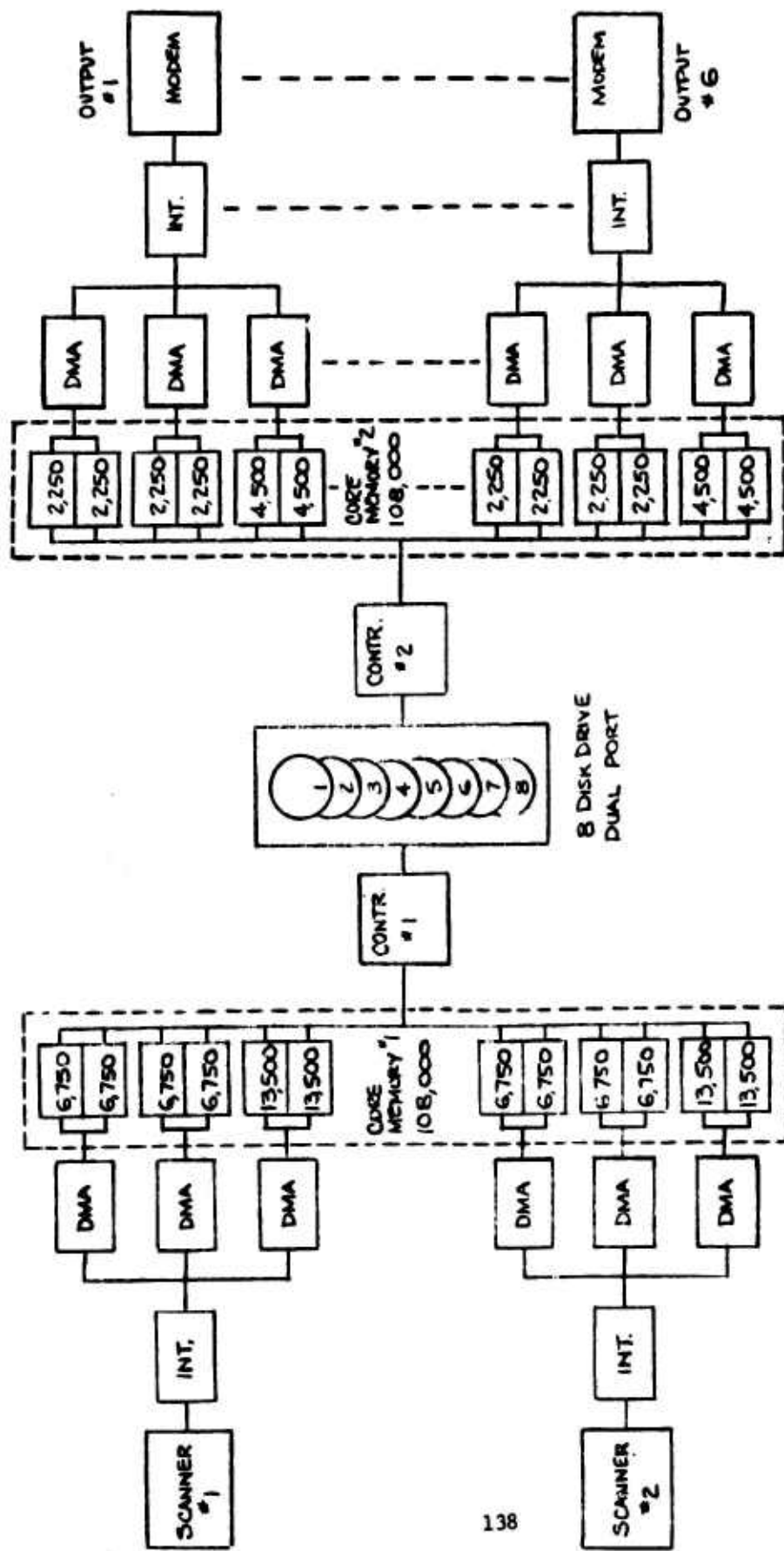

COMPUTER CORE ALLOCATION

FIGURE 4-18

In the zoom mode, data is stored in these buffers in the identical order as it was received by the input processor and stored on disk. However, in the normal mode of operation, all of the buffers are filled only with odd line, odd element data and the remaining information (odd line, even elements, and even lines, all elements) is not read out from the disk. This, of course, is all accomplished by suitable programming.

4.5.2.6 Display Update Time. In order to evaluate the time required to update a full display, an analysis must be made taking into account such factors as input and output data rates, computer speed, buffer sizes, access times, number of users, etc. This analysis is performed on a limited basis in the following sections using available information and making use of what appears to be reasonable assumptions. A more detailed analysis is not possible under the scope of this program, however, neither does it appear to be necessary as all of the major problems are discussed.

4.5.2.6.1 Analysis of Data Handling Capability - Input Processor. The microfiche scanner employs a line by line advance method incorporating a continuous motion technique as opposed to an incremental or stepping mode of operation. This implies that the scanning operation cannot be interrupted or slowed down to accommodate any queuing problems arising in the computer. That is, data flow must be constant into core memory buffer during scanning of a page although it can be postponed or delayed between pages. Therefore, the computer must be capable of accepting data continuously and simultaneously from two scanners, each operating at a 2 megabit/second rate without allowing its buffer to overflow at any time.

As described in Section 4.5.2.5.3, each scanner has a double buffered block assigned to it in core memory. In order for the input and output data flow (through the core memory) to remain in a stable condition, the input must not exceed the output at any time by more than one-half of a scanner buffer. For example, a worst case condition arises when each scanner has one-half of its buffer filled. At this point, the computer must be able to transfer data from one half of one double buffer on to disk, access another disk, and transfer data from one half of the second double buffer on to disk, all before the previously empty halves of the two double buffers are filled at which time the original condition will exist and the cycle may be repeated. If this requirement cannot be met, an overflow condition will eventually result causing loss of data.

If the following equation is satisfied, the system will operate correctly in accordance with the above provisions.

$$T_{F1} \geq T_{E1} + T_A \quad (4-3)$$

T_{F1} = time to fill one half of a double buffer

T_{E1} = time to empty one half of a double buffer

T_A = maximum disk track access time

since

- a) One half double buffer = 27,000 words
- b) One word = 16 bits
- c) Scanner rate = $2 \cdot 10^6$ bits/second
- d) Disk transfer rate = 1 word/2.5 μ seconds
- e) Maximum track seek time = 50 milliseconds
- f) One disk revolution = 16.6 milliseconds

then

$$\begin{aligned} T_{F1} &= \frac{27000 \text{ words} \times 16 \text{ bits/word}}{2 \times 10^6 \text{ bits/second}} \\ &= 216 \times 10^{-3} \text{ seconds} \end{aligned}$$

$$\begin{aligned} T_{E1} &= 27000 \text{ words} \times \frac{2.5 \times 10^{-6} \text{ seconds}}{\text{word}} \\ &= 67.5 \times 10^{-3} \text{ seconds} \end{aligned}$$

$$\begin{aligned} T_A &= 50 \times 10^{-3} \text{ seconds (seek time)} + 16.6 \times 10^{-3} \text{ seconds} \\ &\quad \text{(one revolution)} \\ &= 66.6 \times 10^{-3} \text{ seconds} \end{aligned}$$

Substituting these values into (4-1) results in

$$\begin{aligned} 216 \times 10^{-3} &> 135 \times 10^{-3} + 66.6 \times 10^{-3} \\ &> 201.6 \times 10^{-3} \end{aligned}$$

Therefore equation 4-1 is satisfied and the system speed is adequate to handle a worst case situation. At any rate such an occurrence as above is highly improbable as the program control will always endeavor to place the data from each scanner on separate disks. This will result in a lowering of T_A to $16.6 \cdot 10^{-3}$ seconds due to the overlapped positioning operation of the disk storage system.

4.5.2.6.2 Analysis of Data Handling Capability - Output Processor. The output processor is intended to handle up to six high speed output channels. The higher the number of channels used and the higher the frequency of use, the greater the load that is placed on the system. As can be seen from the queuing analysis presentation in Section 4.4, it is possible to overload the output processor such that waiting times and waiting lines grow beyond manageable sizes and the system no longer serves its purpose. However, by proper programming techniques and by setting reasonable "frequency of use" limitations (i.e., practical system load considerations), the possibility of such an event occurring can be kept to a very low probability. Maximum parameter values were used in the input processor analysis because the flow of input data is required to be continuous with no interruptions allowed (again, this is true only during a page scan and not between pages). Therefore calculations were made to ensure that sufficient buffer memory was available under worst case conditions. In this analysis, it is the average performance over a long time that is of interest and not what happens during a short period. Therefore, average parameters are used throughout the remainder of this discussion. Many of the values assumed relating to user operation are based on estimates and therefore open to question. However, since no valid data is available it has been attempted to use relatively pessimistic values in order to perform a realistic system evaluation. The result, then, should give a satisfactory indication of the manner in which the system will function during the course of a day (8 hours or longer).

Additional definitions and values required in this analysis are:

T_{F2} = time to fill one half of the output double buffer

T_{E2} = time to empty on half of an output double buffer

since

a) One half of an output double buffer = 9000 words

b) One word = 16 bits

c) Disk transfer rate = 1 word/2.5 μ seconds

d) Output Channel rate = 300 kbits/second

then

$$\begin{aligned} T_{F2} &= 9000 \text{ words} \times 2.5 \cdot 10^{-6} \text{ seconds/word} \\ &= 22.5 \cdot 10^{-3} \text{ seconds.} \end{aligned}$$

$$\begin{aligned} T_{E2} &= \frac{9000 \text{ words} \times 16 \text{ bits/word}}{3 \cdot 10^5 \text{ bits/second}} \\ &= 480 \cdot 10^{-3} \text{ seconds} \end{aligned}$$

A full display consists of

$$\begin{aligned} N_D &= \frac{1160 \text{ elements/line} \times 1500 \text{ lines}}{16 \text{ elements/word}} \\ &= 108,750 \text{ words} \end{aligned}$$

Therefore, the minimum time required to transmit and display a full picture is

$$\begin{aligned} D_{\min} &= \frac{108,750 \text{ words} \times 16 \text{ bits/word}}{3 \cdot 10^5 \text{ bits/second}} \\ &= 5.8 \text{ seconds} \end{aligned}$$

In order to determine the average update time, other events which may occur must be considered and their impact on overall performance evaluated.

Additional data to be used includes:

(e) The average track access time on a disk is T_{AD}

where,

$$T_{AD} = 36 \cdot 10^{-3} \text{ seconds}$$

(f) The average track access time when the tracks lie on separate disks is $8.3 \cdot 10^{-3}$ seconds. This results because of the overlapping positioning feature of the RJPO4 storage system. While one drive is reading or writing, one or more drives can be positioned to the new disk for the next transfer. Therefore only one half the rotational latency composes the average access time in this case and

$$T_{AS} = 8.3 \cdot 10^{-3} \text{ seconds.}$$

The Input Function Routine will be designed to assign input data in a uniform distribution over the eight available disks, so that each time a data request is received, there is equal probability that any given disk will contain the desired information. In addition, it will also be the responsibility of this routine to make certain that the two input scanners are not assigned to the same disk at the same time. Therefore, since there are two scanners and eight disks, the probability that the data for an input request resides on a disk being used by a scanner is 0.25. To examine what happens in such an instance assume both scanners are in use on tracks labeled A and B, each on a separate disk. At some time, a data request is received from track C which is on the same disk as track A. Referring to the sequence of operations described in Section 4.5.2.6.1 and again starting with the worst case condition at track A, there are $216 \cdot 10^{-3}$ seconds to transfer data to tracks A and B (a total of $135 \cdot 10^{-3}$ seconds), and to allow access time from A to B ($8.3 \cdot 10^{-3}$ seconds). This leaves

$16.6 \cdot 10^{-3}$ seconds to access track C and return to track B (in order to continue a similar sequence) and $56.1 \cdot 10^{-3}$ seconds to transfer data from track C to the output buffer. Had the sequence begun on track B, it would have had to at some point accessed between A and C which requires $36 \cdot 10^{-3}$ seconds thus leaving only $28.4 \cdot 10^{-3}$ seconds to transfer data to the output buffer. In either case, the amount of transfer time available is sufficient to completely fill the output buffer. Since the output buffer could request access to the disk at any point in the scanner transfer sequence, the average delay time expected is approximately $45 \cdot 10^{-3}$ seconds. This is the overall average of the two possible delay paths. Using the following assumptions, a realistic calculation can be made of the average expected excess transfer time resulting from simultaneous disk requests.

- a. Since there is only 25% probability that requested data will be contained on a disk engaged with inputting scanner data, the average excess transfer time becomes $0.25 \times 45 \cdot 10^{-3} = 11.25 \cdot 10^{-3}$ seconds.
- b. Further assuming that it takes about 25 seconds worst case to unload and reload a scanner in addition to typing in any required information, that there are 0.2 seconds dead time between scanning of successive pages, and that the typical microfiche contains 20 pages, all these factors combine to show that during the scanning operation itself there may be about 30% of the time available when the scanner input is not active. Thus, the transfer time is reduced again to $0.7 \times 11.25 \cdot 10^{-3} = 7.875 \cdot 10^{-3}$ seconds.
- c. The last assumption to be made is that the scanner is utilized for up to 80% during the course of its operating period, so that the average excess transfer time is finally found to be $0.8 \times 7.875 \cdot 10^{-3} = 6.3 \cdot 10^{-3}$ seconds.

If all six channels are busy and simultaneously requesting data from the same disk, a highly unlikely event, the average track access time

is $36 \cdot 10^{-3}$ seconds. Since it requires $22.5 \cdot 10^{-3}$ seconds to fill an output buffer and the average excess transfer time is $6.3 \cdot 10^{-3}$ seconds, the total cycle time required to fill each buffer is $6(22.5 + 6.3 + 36) \cdot 10^{-3}$ seconds = $388.8 \cdot 10^{-3}$ seconds. As it takes $480 \cdot 10^{-3}$ seconds to empty a buffer it can be seen that there is ample time provided to prevent any increase in average transmission time of the image data. Therefore, the average display update time is 5.8 seconds.

4.5.2.7 Concentrator. The concentrator is a PDP11/45 computer which is presently at FTD and will be used essentially as a traffic controller. Its main functions are:

- a. Search library file contained in FTD IBM 360 computer when requested by one of the display terminals.
- b. Transfer all microfiche requests to the Index Control Program residing in the output processor.
- c. Indicate to the terminals the data channel to be used.

The concentrator will communicate with the output processor by means of a 9600 baud line and with the display terminals by means of multiplexed 48 kilobit channels. This will allow the concentrator to control all communications from the display terminals to the Microfiche and/or Library computers.

4.5.3 SOFTWARE

A significant portion of the microfiche system design effort is concerned with the development of software programs to control computer operation.

The design is critical in order that the system function not only correctly, but also efficiently, when heavy loads, in the form of multiple data requests, are placed upon it. Various tasks are assigned to particular processors in the system as described in the following sections. In attempting to understand the interrelationships among the programs, reference should be made to the software flow chart in Figure 4-19.

4.5.3.1 Input Processor Software. There are four major programs concerned with input processor operation. They are responsible for accepting and processing input data, communicating with the output processor, and overall processor control. A short description of the items for which each program is accountable is given in the succeeding paragraphs.

Scanner Input Routine

This program permits the input processor to accept data from two microfiche scanners, each scanner having a 3 channel output as is required for proper formatting of the digitized data. Input core buffer areas are assigned to each scanner (one double buffer for each channel input) by the routine which also initiates direct memory transfers by the use of DMA (Direct Memory Access) devices.

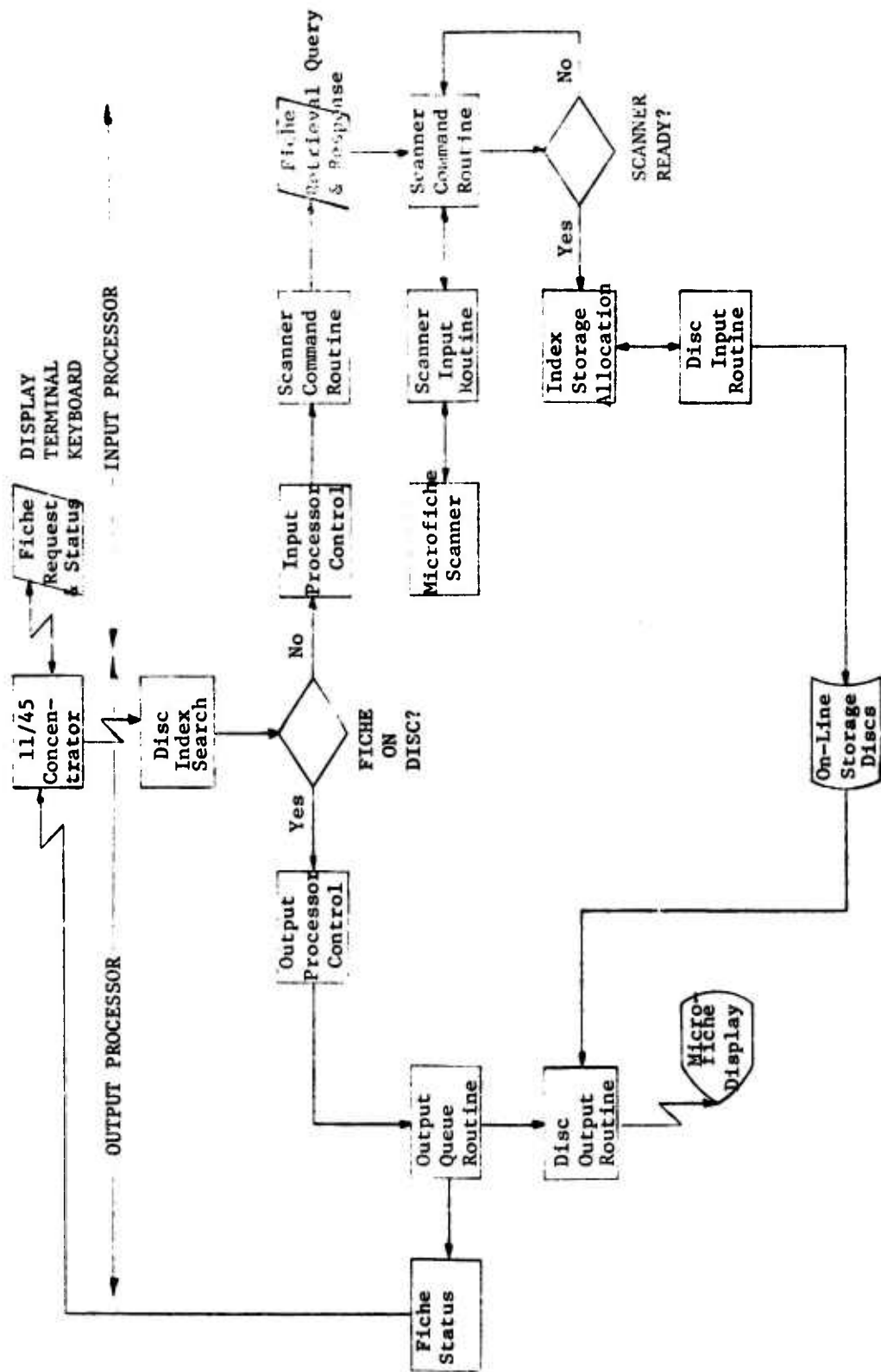

SOFTWARE FLOW CHART

FIGURE 4-19

Scanner Command Routine

The first obligation of this program is to accept microfiche data requests from the output processor and relay the data to the scanner data entry control terminal which is a printer with keyboard entry. It also accepts data from the terminal indicating both microfiche and scanner unit identification and subsequently informs the Index Control Routine in the output processor when a particular microfiche and page are about to be input.

Disk Input Routine

The function of this routine is to accept data from the scanner input buffers (as assigned by the Scanner Input Routine) and transfer it to disk storage in the proper order. In addition, the Disk Input Routine accepts storage parameter intelligence from the output processor Index Control Routine. These storage parameters include disk number, track number, etc., that is, all information required to determine the disk location for the image data.

Input Processor Control Program

This program governs overall input processor operation. It must call input/output routines as needed and in proper order. All operations must be monitored on a continuous basis in order to avoid buffer overflow and to prevent any conflicts with the output processor routines, especially with regard to disk image.

4.5.3.2 Output Processor Software. The output processor also requires four major programs. Their duties include communicating with the input processor and concentrator, processing output data, avoiding queues, storage assignments, and overall processor control. The requirements of the specific programs are briefly discussed in the ensuing paragraphs.

Index Control Routine

The initial mission this program must perform is acceptance of normal or zoom image requests from the FTD concentrator. If the image has already been stored, the routine locates the desired page address or location from the Index File and gives this information to the Output Queue Routine. If the requested microfiche has not yet been scanned and stored, the routine assigns space and transmits the microfiche request data to the Scanner Command Routine in the input processor. Space must be allocated in a uniform fashion to prevent undesirable queues from forming. For example, the two input scanners should always be operating with separate disks. When informed that the microfiche is ready to be scanned, the Index Control Routine sends the data storage location parameters to the input processor Disk Input Routine. In addition, as the individual page location assignments are transmitted to the input processor, the information is recorded on the Index File for future reference.

Output Queue Routine

This routine accepts data location parameters from the Index Control Routine and gives them to the Disk Output Routine. It also transmits microfiche identification and page number to the concentrator and informs it as to which high speed channel will be used.

Disk Output Routine

Data storage parameters from the Output Queue Routine are accepted by the Disk Output Routine which assigns output buffers for the data transfer. These buffers are also assigned to a high speed modem interface using three DMA channels. All DMA transfers are initiated by the Disk Output Routine. It is the responsibility of this routine to keep all output buffers filled and to inform the Output Queue Routine which high speed output data channel is to be used.

Output Processor Control Program

Overall output system operation is under the authority of the Output Processor Control Program. Its functions include activating the input/output routines in correct sequence as needed and to continuously monitor all other tasks to prevent any conflicts with the input processor routine.

4.5.3.3 Concentrator Software. In addition to programs already in the concentrator, a number of other routines must be added to interact with them. Their functions basically are concerned with traffic control as described in the following paragraphs.

Library Search Routine

This program accepts data requests from the display terminals for abstract information and sends it to the Library Abstract Computer (IBM 360). It then accepts replies from the Library Abstract Computer and routes the information to the requesting terminal via a multiplexed 48 kilobit/second data channel.

Image Request Routine

Requests for particular microfiche to be scanned and input to the system or for individual pages of previously scanned microfiche are routed to the Index Control Routine in the output processor. This routine also monitors the multiplexer output to determine when a request from a terminal is ready for execution.

Image Status Routine

This program accepts image parameter data from the output processor and sends it to the appropriate terminal. Relevant information includes such items as insufficient request data/queueing status, and channel number assigned for data transmission.

4.5.3.4 Diagnostic Routines. In addition to all the programs described above, a number of diagnostic routines must be provided. These will be used to monitor all functions to ensure proper operation of the system during actual use. In addition, they can be used as debugging aids in the event of a system failure. It will be possible to use them in conjunction with output printers or displays to help in determining the cause of any problems.

4.5.4 SCANNING SYSTEM

As a result of analyzing the requirements of the entire Microfiche Scanner-Remote Display System, a set of functional and technical specifications for the scanning portion of the system were established. These specifications were presented in Section 3.1.2 and are repeated below.

Functional Specification

Scan, digitize and transmit data recorded on the microfiche

Interact with the computer:

Accept commands

Transmit data and status

Technical Specifications

Scan format	-	9.0mm x 11.6mm (per page)
# of pixels/line	-	2320
# of lines/page	-	3000
Signal-to-noise ratio	-	20 at 130 lp/mm
Output bit rate	-	2 Mbits/sec
Microfiche Format	-	Standard 4" x 6" - 24X with 98 pages

4.5.4.1 Scanning System Configuration. Upon selection of the Reticon solid state arrays a scanning system was configured that will meet the above specifications. This system is shown in block diagram form in Figure 4-20. The functions and requirements of the major blocks in the diagram are discussed in the sections that follow.

4.5.4.1.1 Light Source. The saturation exposures for the solid state arrays are functions of the array element size. Nominal saturation exposure values,

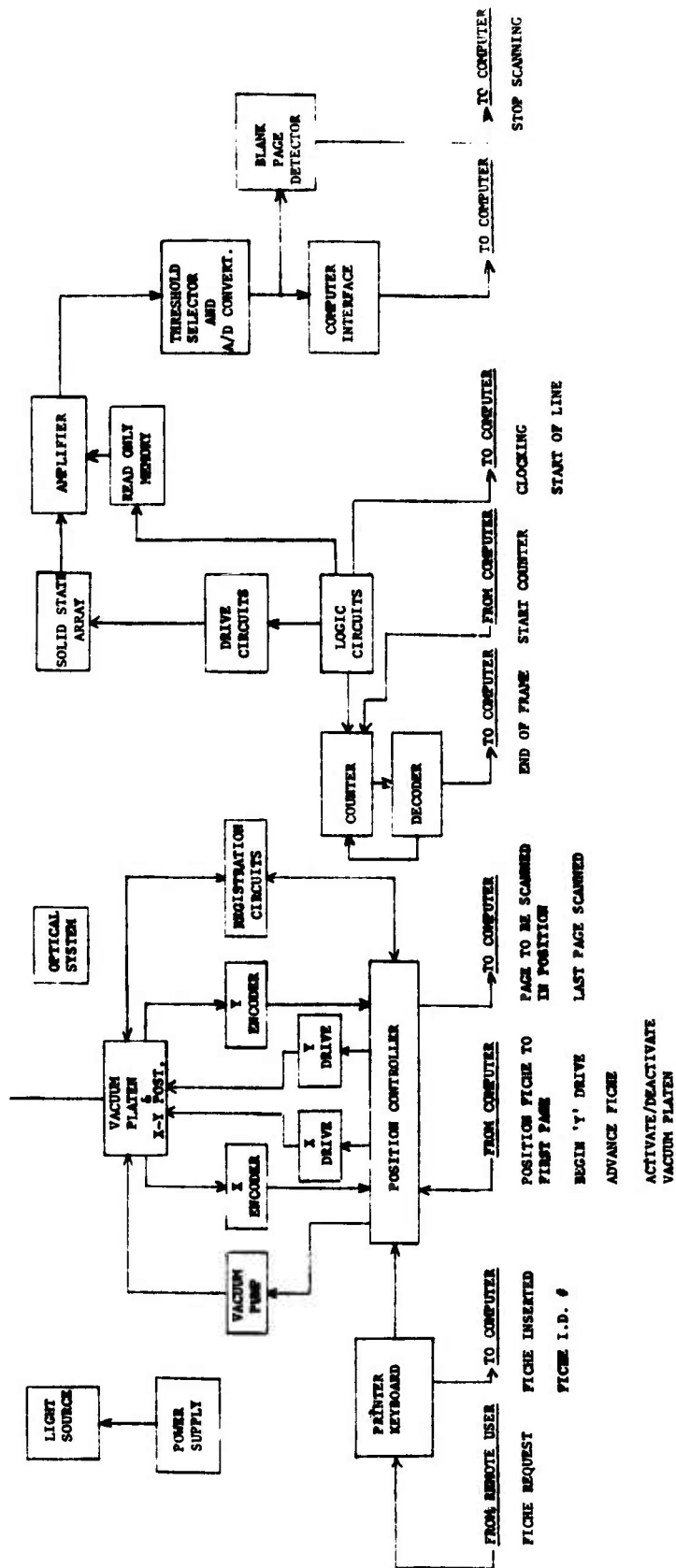

SOLID STATE SCANNING SYSTEM BLOCK DIAGRAM

FIGURE 4-20

however, are of the order of $(5-10) \times 10^{-6}$ joules/cm²*. Since the exposure time per element is of the order of 1 millisecond, the corresponding saturation light intensity at the array plane is approximately $(5-10) \times 10^{-3}$ watts/cm². The light source, therefore, should have an output intensity consistent with this image (array) plane intensity requirement.

4.5.4.1.2 Vacuum Platen. The purpose of the vacuum platen is to hold the microfiche in the object plane of the optical system during the scanning process. Since the fiche will be illuminated from behind, this platen must be transparent.

4.5.4.1.3 Transport and Transport Controller. The function of the transport is to position, in sequence, the microimages on the fiche into the scanning position. In addition, the transport must, during the scanning process, move the fiche at a constant speed along the direction of the page height.

In order to minimize the amount of "overscan" required to capture a complete page, the page should be positioned into the scanning position to within ± 0.005 inches - both along the width of the page and the height. This can be achieved through use of the internal capabilities of the transport controller and additional "registration" circuitry. In addition, the time required to step from one page to the next should be of the order of 0.2 seconds for adjacent pages and no more than 1.0 second in going from the end of one row of pages to the beginning of the next row.

*For 2870°k tungsten light

Based upon the number of pixels per page and the output bit rate, the time required to scan a page will be approximately 3.5 seconds. Since the page height is 11.6mm, the velocity at which the transport must move during scanning is $11.6/3.5 = 3.3\text{mm/sec}$ (0.13 inches/sec).

In addition to controlling the motion of the microfiche through internal feedback loops, the position controller should also "communicate" with the computer. Typical commands that it might receive from the computer are:

Position fiche to first page
Begin "Y" drive
Advance fiche to "next page" position
Advance fiche to load-unload position

In turn, the controller should send status data back to the computer. Such data might include:

Page to be scanned in position
Page # 98 scanned

4.5.4.1.4 Optical System and Solid State Array Selection. The optical system must be configured around the selected solid state arrays. To achieve the required number of pixels per line width, a combination of a Reticon 1872 element and a Reticon 512 element array are recommended. The geometry of these arrays, however, prevent them from being physically "butted-up" to form an equivalent 2384 element array with no "dead space" between them. In addition, the element sizes associated with these two arrays are different. The 1872 array element size is 15 microns x 16 microns, while the 512 array element size is 25.4 microns x 25.4 microns. Consequently, the image magnification requirements associated with each array is different. Since the pixel size at the fiche plane is approximately 3.8 microns x 3.8 microns $[9\text{mm} + (1872+512)]$, the magnification factor for the 1872 element array is 4.1X while for the 512 element array it is 6.7X.

An optical system configuration that will meet the requirements imposed by the arrays selected above is presented schematically in Figure 4-21.

As shown in this diagram, a beam splitter and two lens are used to generate two separate images of the page being scanned. By proper positioning of the optical elements, the required magnification factors can be obtained while at the same time maintaining a common image plane. The two arrays are then positioned at the image plane in front of the image having the appropriate magnification factor. By proper positioning along the image plane, the two arrays can be made to scan the entire width of the page with no loss or redundancy in information output.

Based upon the performance analysis described in Section 3.1.2.1, the lenses used in this system should have a response of 50% to 60% at 130 lp/mm (related to the microfiche) over the 9mm format width and at the appropriate magnification ratios.

4.5.4.1.5 Solid State Array Logic, Drive and Counting Circuits. The basic logic and drive circuitry required to operate the arrays are standard circuit boards available from Reticon. Signals from a master clock on these boards can be used to trigger the clocking out of the signals from the array elements. By proper triggering, the output signals from the two arrays can be combined into a single stream of data. Pulses from the logic circuits can also be used to provide the computer with clocking and "start of line" information.

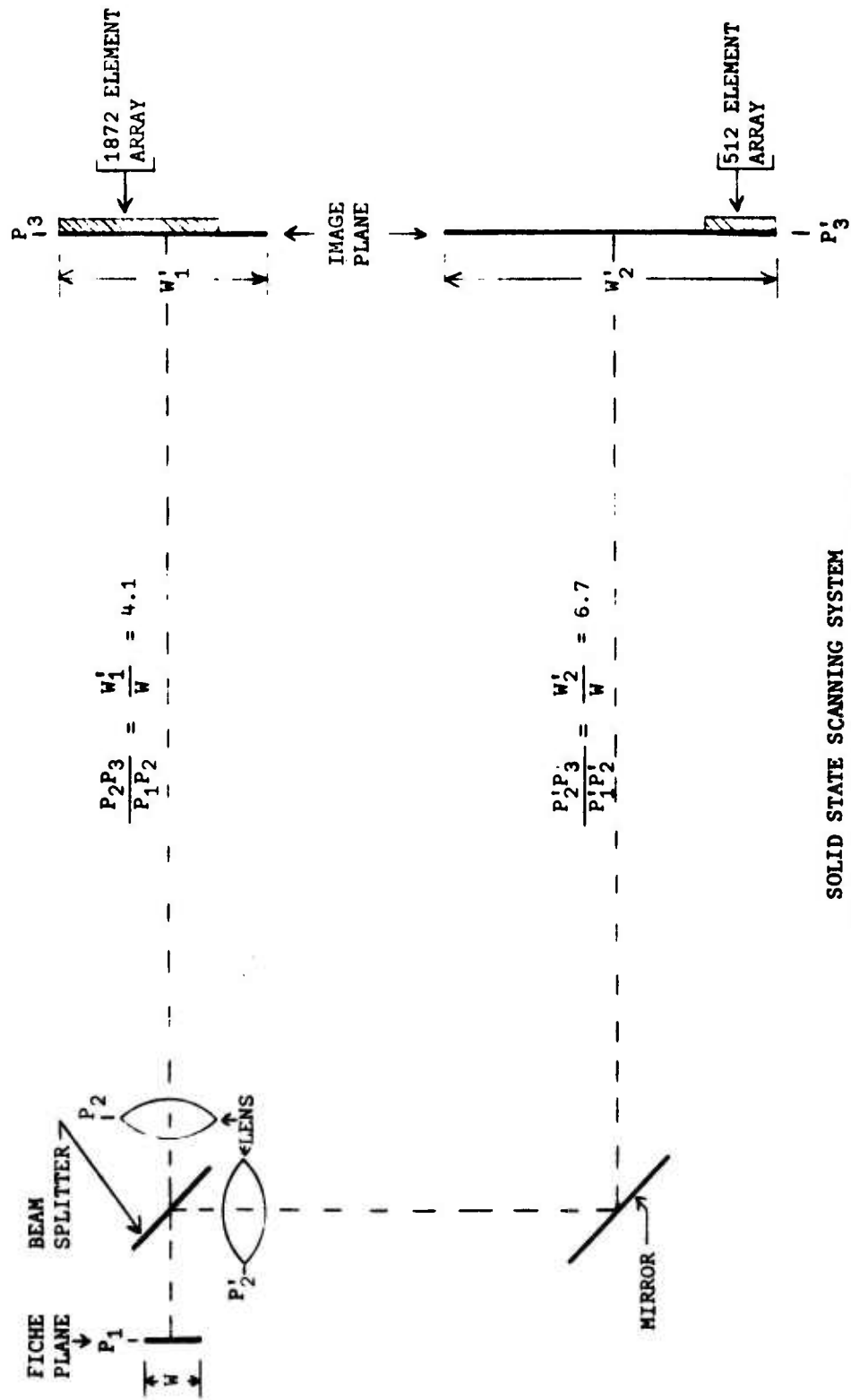

SOLID STATE SCANNING SYSTEM
OPTICAL SYSTEM-ARRAY CONFIGURATION

FIGURE 4-21

A counter-decoder circuit can be used to provide "end of page" information to the computer. This can be achieved by using the counter to count the "start of line" pulses from one of the logic circuits as the page is being scanned. Upon reaching a count of 3000 (lines/page), a signal is sent to the computer indicating that the page has been completely scanned.

4.5.4.1.6 Amplifier and Read Only Memory. The signal from the array is fed into a current amplifier. In order to compensate for variations in the sensitivity (output charge per unit input intensity) of the array elements, the gain of the amplifier is controlled by a read only memory. This memory can be programmed such that the amplifier gain is inversely proportional to the sensitivity of each element of the array on an element-by-element basis. Thus, while the signal out of each element can vary an estimated $\pm 12\%$ for a given light exposure, the signal out of the amplifier under the same conditions will essentially remain constant.

4.5.4.1.7 Threshold Selector and A/D Converter. The function of the threshold selector is to analyze the output video signal corresponding to density variations on the microfiche and establish the optimum threshold level. Upon selection of this level, signals above this level are digitized as 1's (white pixels) and signals below this level are digitized as 0's (black pixels).

4.5.4.1.8 Blank Page Detector. The function of the "Blank Page" detector is to "recognize" when all of the pages on a fiche not containing a full 98 images have been scanned out. One method of doing this is to count the number of transitions (white-to-black and black-to-white) that occur as the page is being scanned up to a minimum number of counts, N. If, N, transitions are actually counted, the detector defines that page as having information content. However,

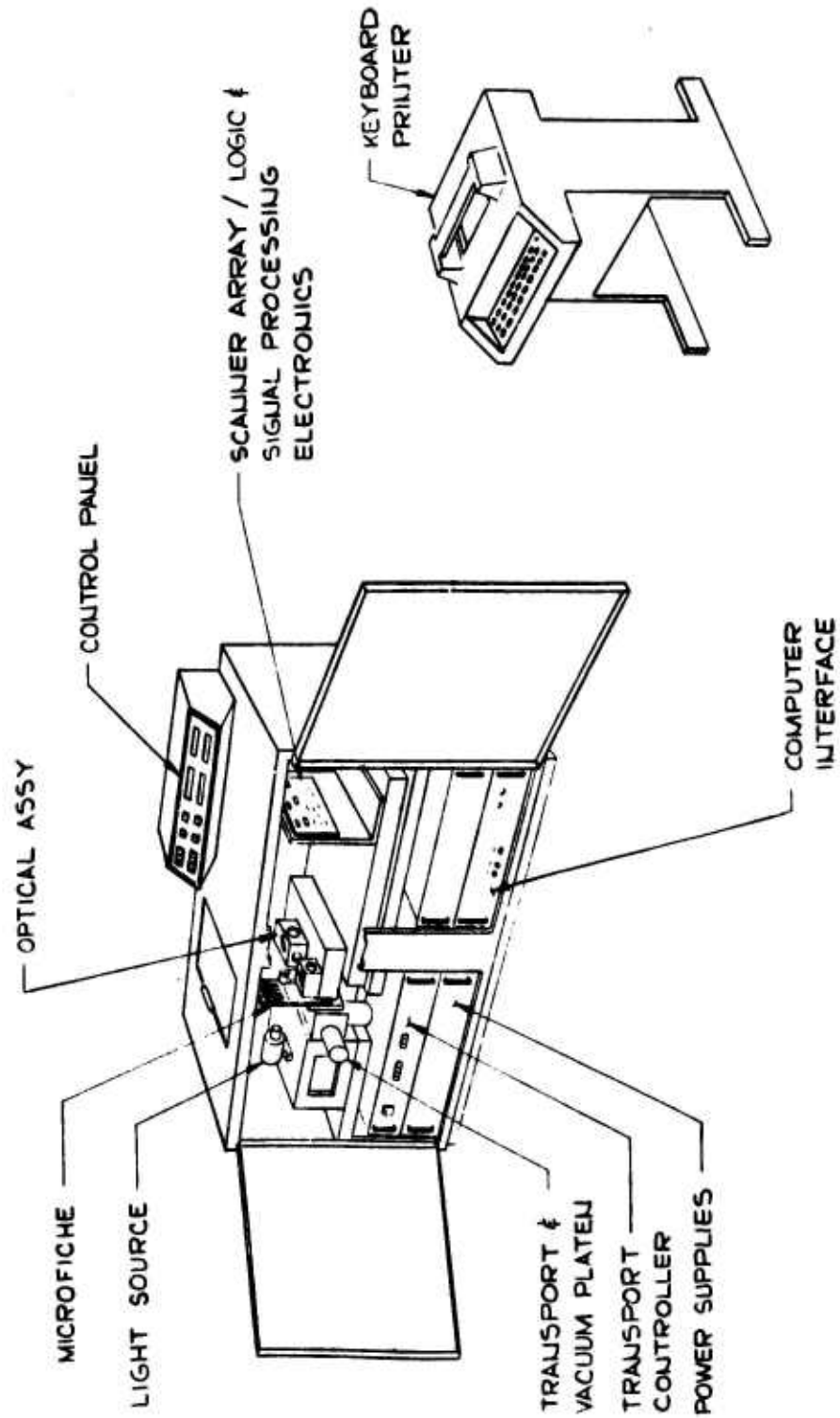

CONCEPTUAL SKETCH OF SOLID STATE SCANNING SYSTEM

FIGURE 4 - 22

if less than, N, transitions are counted during scanning of a full page, the detector defines that "page" as blank and sends a "stop scanning" command to the computer. The selected value for, N, will depend upon how many transitions can be expected from only noise sources (blemishes, dust, lint, etc.) on the fiche.

Using such a detector will prevent the scanner from sending more than one blank page from any given fiche to the computer.

4.5.4.1.9 Computer Interface. The requirements and functions of the computer interface are discussed in Section 4.5.5.1 and will not be repeated here.

4.5.4.1.10 Printer - Keyboard. The purpose of the printer - keyboard is to permit the operator of the scanner to communicate with the remote users and also with the computer. Typical information from a remote user might be in the form of requests for fiche to be scanned and sent to his display. In turn, such status data as appropriate fiche identification and "fiche ready to be scanned" might be sent by the operator to the computer.

4.5.4.2 Scanning System Packaging Concept. A detailed design effort must be done before an actual scanning system package can be defined. Such considerations as ease of operation, ease in maintainability and other human factors must be thoroughly investigated. Figure 4-22 presents, however, a conceptual sketch of how the system might look.

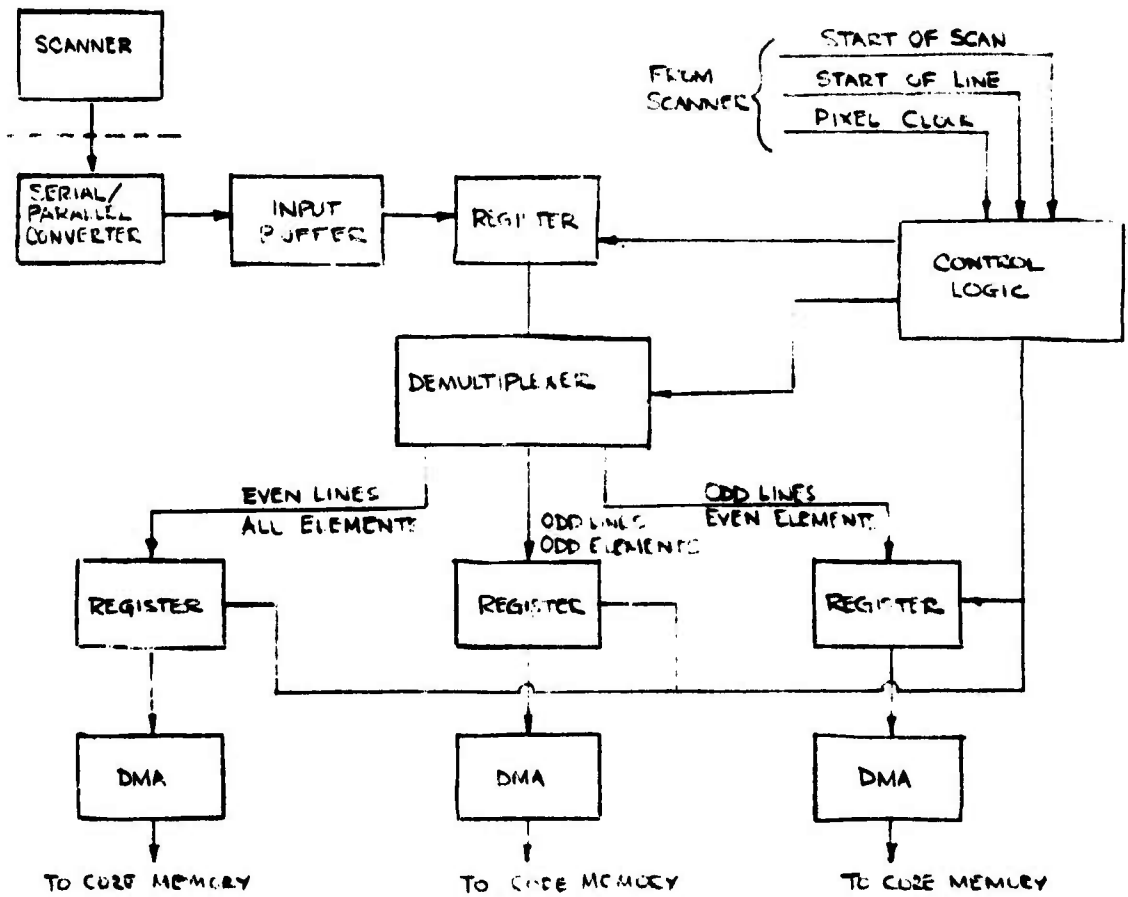

SCANNER/COMPUTER INTERFACE - BLOCK DIAGRAM

FIGURE 4-23

4.5.5 INTERFACES

Due to the unique combination of software and hardware incorporated in the design to permit simple generation of zoom pictures, a number of special interfaces are required. After the microfiche image has been scanned and digitized, it must be properly formatted before it is transferred to storage on disk. Again, when the data is transferred from storage and out of the computer, it must be reformatted before transmission at high speed to the output terminal. At the terminal, the data must be converted to analog form and suitable sweep circuits activated to control the display horizontal and vertical scan directions. These devices are described in the following sections.

4.5.5.1 Scanner - Computer Interface. Figure 4-23 is a block diagram of the interface between a scanner unit and the input processor. The digitized data is received from the scanner in serial fashion. It is then converted into parallel data consisting of 16 bit words which are compatible with the processor mode of operation. A FIFO (first in - first out) buffer of at least 64 words is provided to compensate for any short duration differences in data rates arising from the asynchronous mode of operation employed between the scanner and processor. The buffer allows data to accumulate at times when the processor is performing functions which prevent it from accepting the input at a uniform rate. Then, when the processor is available, data is taken from the buffer at a rate exceeding the input from the scanner. A 16 bit register is provided at the buffer output to hold a word while the control logic determines where the data is to be transferred and gives appropriate commands to a demultiplexer unit which acts as a traffic director. Three DMA (Direct Memory Access) devices are used to input information into predetermined core buffer blocks in the input processor. Data is channeled to the correct DMA through the demultiplexer with registers provided in each line to hold a word during the input cycle. Scan data is assigned to a particular DMA in accordance with the following partitioning criteria:

- a. odd lines, odd elements,
- b. odd lines, even elements, and
- c. even lines, all elements.

Three DMA devices are used because data is stored in three separate buffer blocks. Use of one DMA would require interleaving of data into core memory which would ultimately result in an intolerable decrease in overall system speed.

The control logic section both generates and receives signals to control the DMA communication cycle. In addition, it interacts with the scanner using such inputs as the pixel clock, start of line, etc. and also instructing the scanner to stop between pages if, for example, the processor should, for some reason, be unable to accept data on a continuous basis. The logic also keeps track of, and sends to the processor, the sequence number of each page being scanned.

4.5.5.2 Computer-Modem Interface. The block diagram in Figure 4-24 illustrates the interface required between the output processor and the high speed channel modem. Again, in order to conserve program operating time, three DMA units are used to extract data from the three associated core buffer blocks in the processor memory. In the zoom mode, data is transferred from disc storage to the three core buffers and located according to its classification as shown in the block diagram. A separate buffer is supplied for odd lines, odd element; for odd lines, even elements; and for even lines, all elements. Each buffer is unloaded through its respective DMA unit into an output buffer (composed of FIFO devices) whose use allows asynchronous operation between the modem and output processor. The control logic sends commands to a multiplexer which combines the separated data into its original scanner sequence and then feeds it to the modem for high speed transmission to a display terminal. Communication with the DMA is maintained by the control logic which generates and receives the required control signals.

Operation occurs somewhat differently in generating a normal picture. In this mode, only odd lines, odd element data is used for a display and, therefore, only this type of information is placed in the core buffer while all other information is bypassed. For this case, all data is transferred through a single DMA device and a single output buffer so that essentially a single channel output system is achieved. The multiplexer remains in a fixed address condition and is transparent to the overall operation. All action remains under command of the control logic.

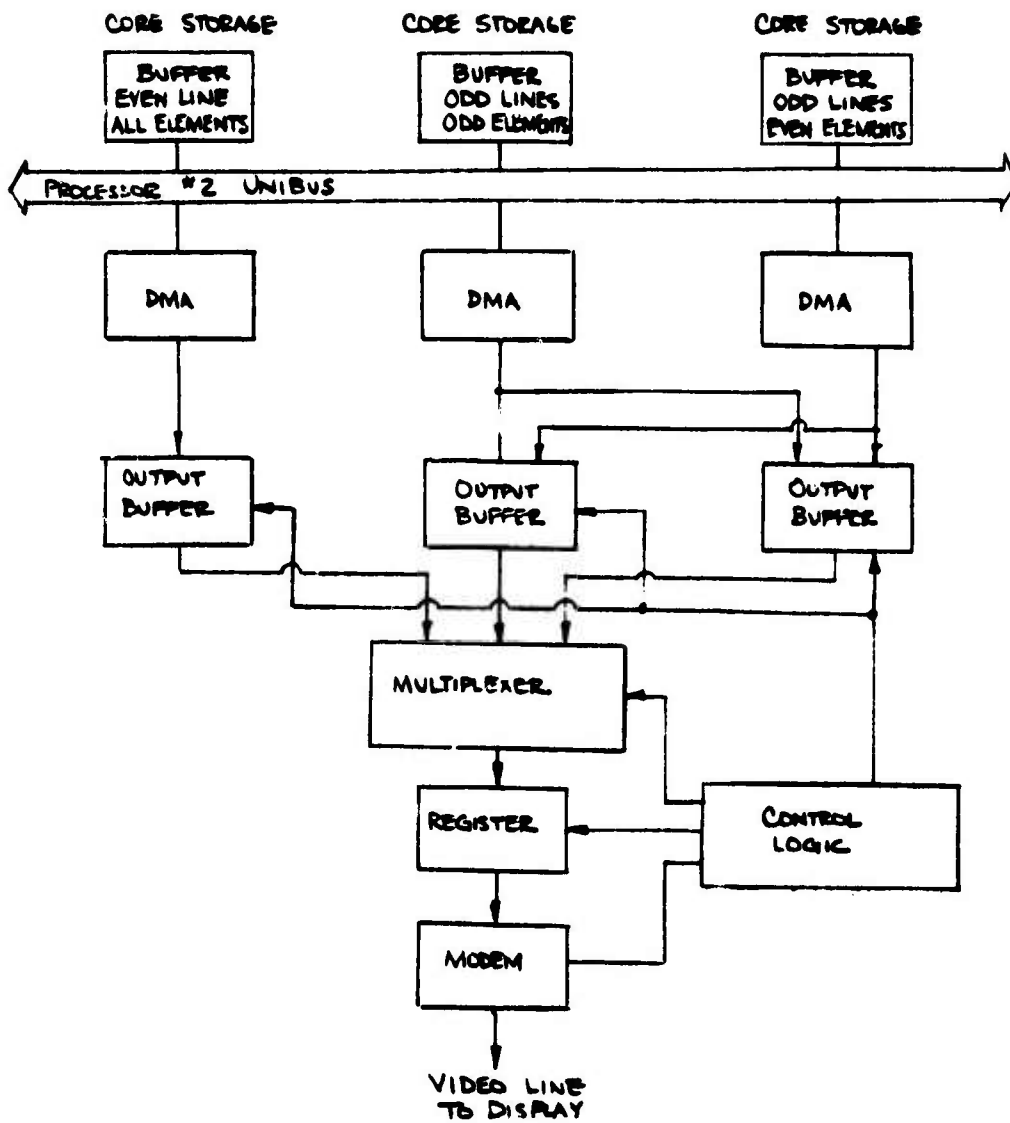

COMPUTER/MODEM INTERFACE - BLOCK DIAGRAM

FIGURE 4-24

4.5.5.3 Modem-Display Interface. Figure 4-25 represents a block diagram of equipment necessary as an interface between the high speed channel modem and the display terminal. The modem is a high speed (300 kbits/second) receive unit only and has an input (not shown here) which instructs it to operate at one of six possible carrier frequencies. A control word detector is required for such signals on Data Ready, Start of Line, etc. An acknowledge generator indicates when data has been properly received and also initiates such signals as Data Request, Not Ready, etc. In addition, a two-line buffer is provided in order that the display line scan rate may operate independently of the data transmission channel. The buffer output feeds the data serially to a beam control amplifier which turns the scanning beam on and off in accordance with the information to be recorded from the buffer.

A linear ramp generator controls the horizontal scan rate and is initiated on receipt of a control signal indicating that the input buffer is full and about to begin sending data to the display. At the finish of a scan line, the ramp circuit generates a signal which tells the control logic that it has completed its retrace and is ready to begin again. Synchronization of the data and ramp is accomplished by the control logic.

The vertical ramp is generated by means of a D/A converter. Thus it is digitally controlled and may be halted or restarted at any given time in order to compensate for any data interruptions which may occur. Because of this, the computer is not required to send data continuously except on a line by line basis. Action of the vertical ramp generator is also under command of the control logic.

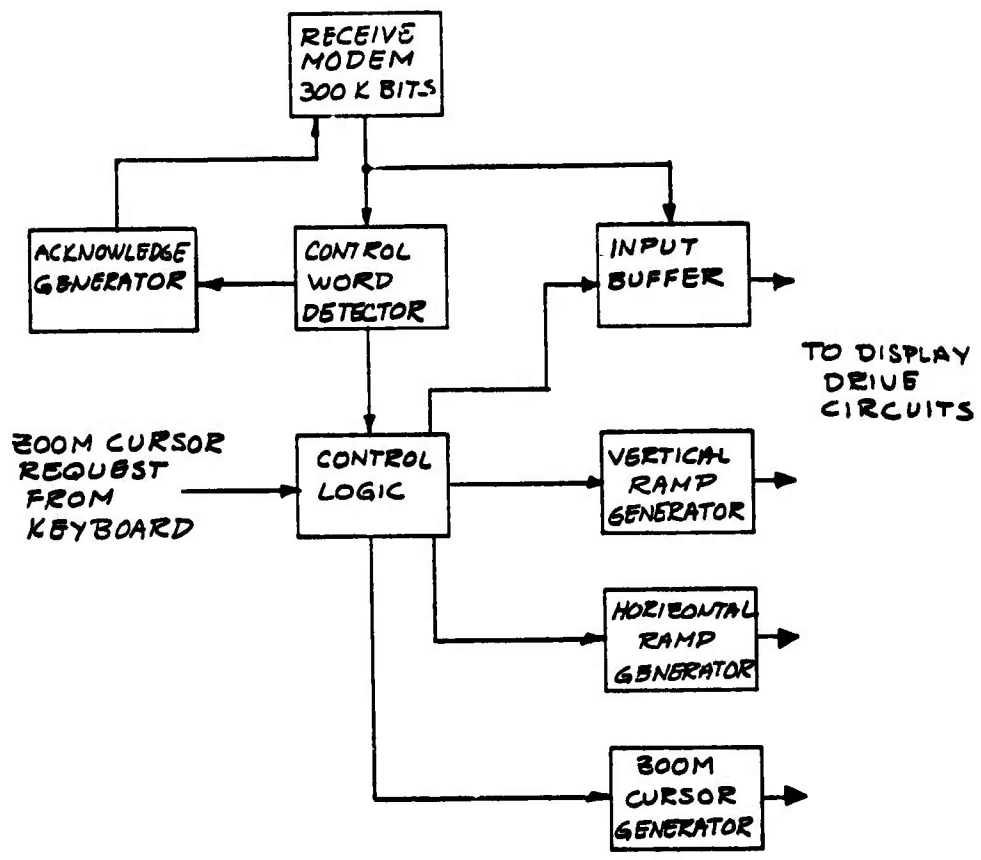

HIGH SPEED MODEM - DISPLAY INTERFACE

FIGURE 4-25

A zoom cursor generator is included to aid the viewer in selecting a portion of a normal display to be presented in the expanded mode. This unit, under control of the terminal operator, will generate on the screen an outline of a box approximately covering one-fourth of the picture area. The operator may move this figure to any desired location on the screen by means of front panel mounted thumbwheel controls. Cursor generation is accomplished by using the display's non-storage mode of operation. This technique drops the recording beam current to a point which is just enough to momentarily excite the display screen, but is not sufficient to store any information. In this manner, a mobile cursor can easily be positioned at any location on a previously stored image. Utilizing the proper front panel controls, the operator can then command the output processor to present the data enclosed by the cursor in the zoom or magnified mode.

The control logic, in addition to synchronizing the data and ramp generators, also generates and detects control characters and/or status signals in order to ensure proper communication with the computer. Typical of such signals are Busy, End of Cycle, End of Line, Start of Line, etc. Zoom cursor requests are also handled by the control logic which both initiates and deactivates the zoom cursor generator circuitry.

There is also a lower speed (48 kbits/second) modem which ties into the display which permits two-way communications with the FTD Concentrator system. However, this unit requires no external modifications and can be interfaced directly to the display terminal which already has provisions to accept such a device.

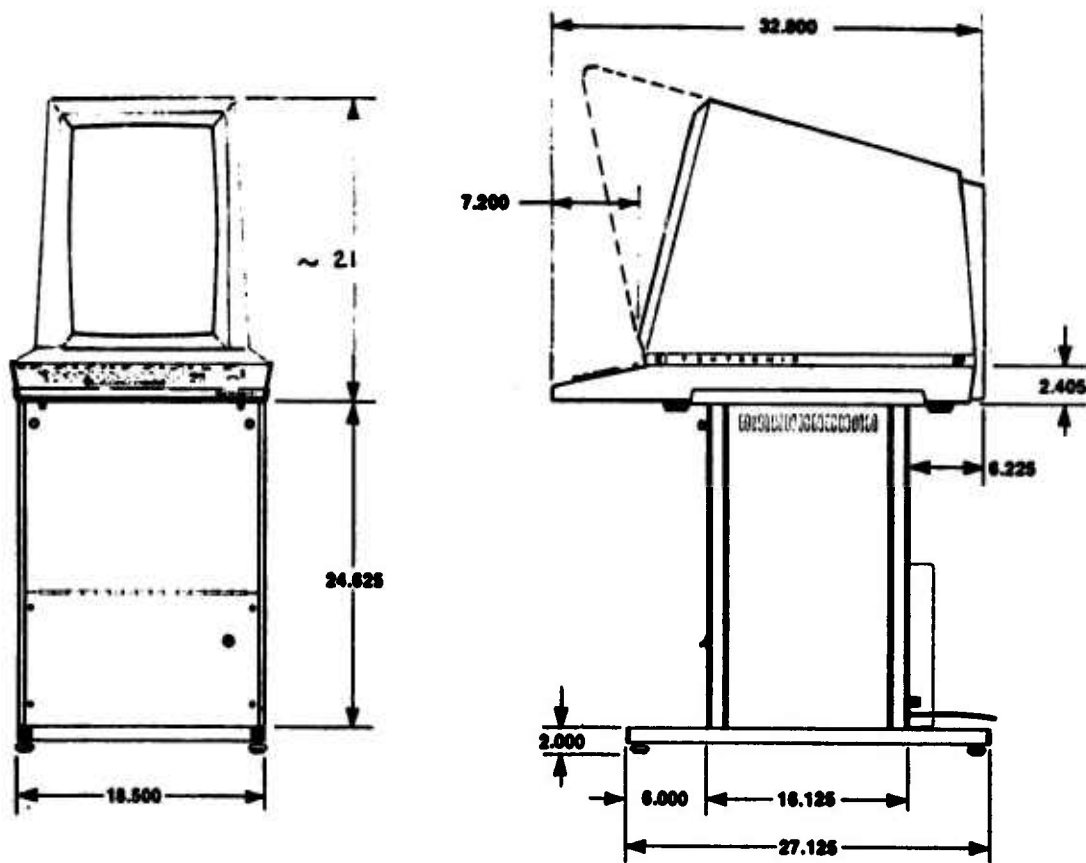

TEKTRONIX #4014-1 DISPLAY OUTLINE DIMENSIONS

FIGURE 4-26

4.5.6 DISPLAY TERMINAL

The display terminal selected for the Microfiche Scanner and Remote System is the Tektronix Model 4014-1 Display Terminal provided with a vertically mounted screen and a light hood.

The display unit with keyboard is secured to a pedestal to form a desk high unit as shown in the outline drawing of Figure 4-26. The pedestal contains power supply and control circuitry, character generator, plus communication interfaces and optional interface space. An XYZ Analog Input circuit (940C modification kit) is required to provide an analog interface for transmitting images. A Tektronix Model #4632 Video Hard Copy Unit is compatible with the display and may be added to the Microfiche System as optional equipment whenever desired.

The functional and technical specifications for the terminal are listed below.

Functional Specifications

The terminal must interact with the control computer via keyboard to initiate all operator commands.

The display terminal must be capable of displaying microfiche images.

The terminal must have a built in character generator to transmit and receive (on the display) alphanumeric messages.

The terminal display must provide a cursor overwriting capability for zoom operation.

Technical Specifications

Display Model	-	Tektronix 4014-1
Display Type	-	Direct View Storage CRT
Display Area	-	11" wide x 15" high (vertical mounting)

Keyboard	-	96 characters (full ASCII upper and lower case)
Resolution	-	1500 elements/15" height
Alphanumeric Cursor	-	7 x 9 dot matrix
Graphic Cursor	-	Yes
Writing Rate	-	> 5000 inches/second
Brightness	-	8ft - L at 6:1 contrast ratio
Configuration	-	Display Unit with keyboard secured to pedestal to form a desk height unit
Options	-	940C XYZ analog input card

SECTION V
SYSTEM IMPLEMENTATION PLAN

5.0 GENERAL

A system implementation plan is presented herein which may be exercised in two or three steps during system procurement in order to optimize the risk exposure to the government and spread cost expenditures.

5.1 ENGINEERING SYSTEM

A basic Engineering System configuration of the Microfiche Scanner and Remote Display System can be completed during a 12-month schedule. The Engineering System would provide the essential hardware and software to perform all system verification tests and eliminate all risk for subsequent procurement leading to full system implementation. The Engineering System configuration, illustrated in Figure 5-1, includes the 1st article scanner, the computer with two processors and minimum core and discs. Two display terminals, interfaces, and high speed modem sets will be provided. The system represents the minimum configuration needed to validate equipment, software and system performance. The Engineering System equipment can be directly applied to the final operational system.

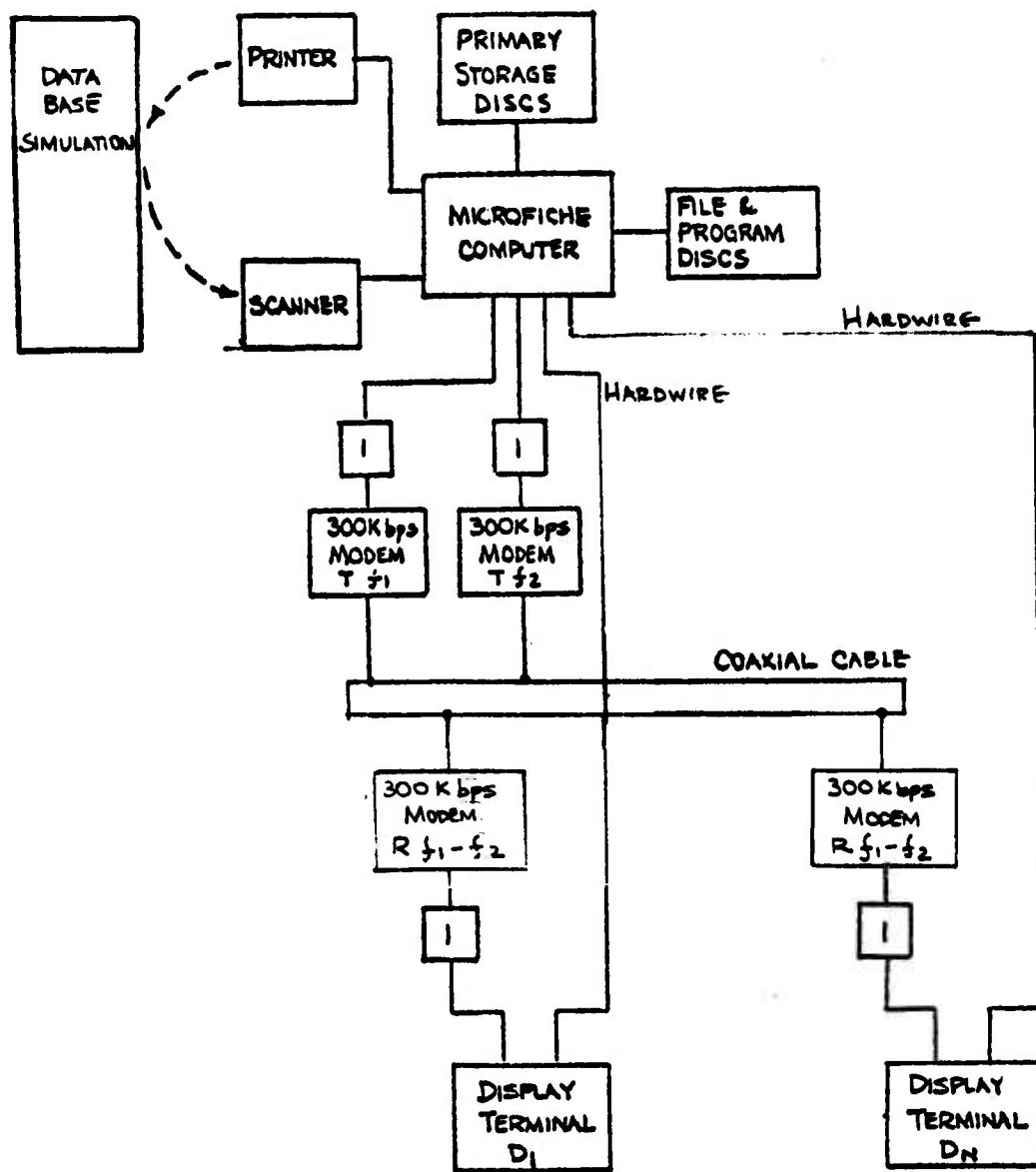

ENGINEERING SYSTEM CONFIGURATION

FIGURE 5-1

5.2 INITIAL OPERATIONAL CONFIGURATION

The next phase in the implementation is to provide an Initial Operational Configuration which is deliverable as an operational system to FTD. It represents a complete system with 40 remote terminal stations. The Initial Operational Configuration is built up by adding equipment to the Engineering System including: a second scanner, additional computer core and disks, 38 display terminals with modems, and 4 high-speed transmit-only modems. In addition, a 9600 bps line, 48 Kbps modems, and a multiplexer are supplied to interface with the FTD updated facilities. Some additional software must also be prepared. The system can be supplied within 16 months ARO.

5.3 FINAL OPERATIONAL CONFIGURATION

The final phase adds 60 remote stations (display terminals with modems) to provide a Final Operational Configuration of 100 remote stations.

5.4 SYSTEM IMPLEMENTATION SCHEDULE

A schedule for implementation of the various system steps is given in Figure 5-2. All activities required for full system implementation are completed within 24 months.

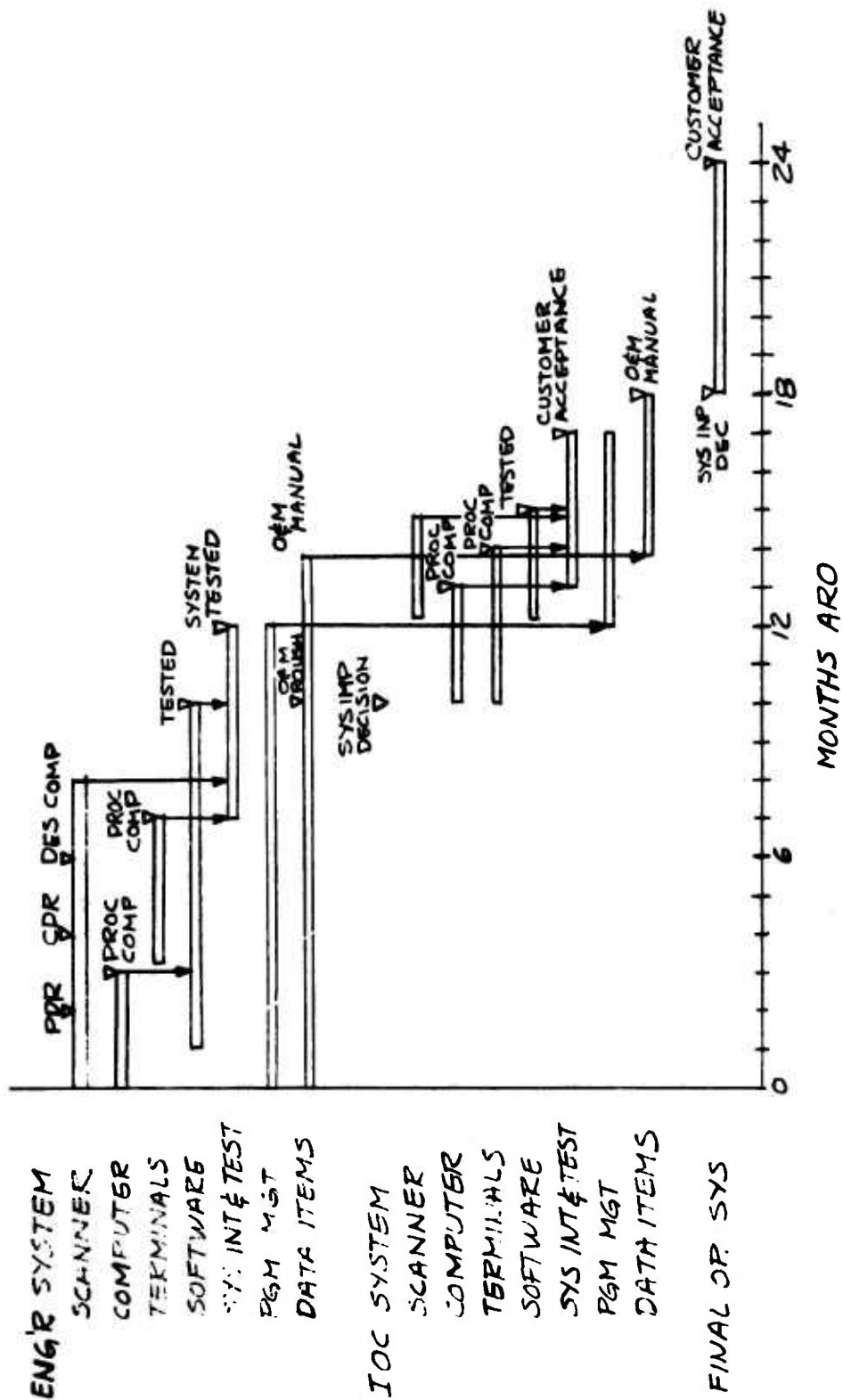

SYSTEM IMPLEMENTATION SCHEDULE

FIGURE 5-2

5.5 SYSTEM COST ELEMENTS

The total system cost structure is estimated in Table 5-1.

TABLE 5-1
TOTAL SYSTEM COST

	<u>Cost</u>	<u>Total</u>
Engineering System (2 Term.) - N/R \$420,000; R \$355,000	\$ 775,000	
Interim Operational Capability (40 Term.)	\$1,240,000	\$2,015,000
Final Operational Configuration (100 Term.)	\$1,175,000	\$3,190,000

Approximately \$420,000 of the total system cost is non-recurring and would not apply to the cost of procuring a second system.

SECTION VI

SUMMARY OF RECOMMENDATIONS AND CONCLUSIONS

A number of recommendations are made based on the conclusions of this study. These recommendations and conclusions are summarized below.

- Based on the results of analyses and simulation experiments conducted during the study, it has been concluded that the Microfiche Scanner and Remote Display System is feasible. The system will provide an efficient and cost-effective interface between a microfiche storage center and remote microfiche users. EPSCO Labs recommends full implementation of the system at FTD.
- EPSCO Labs recommends a two step implementation plan leading to the installation and acceptance of the Microfiche Scanner and Remote Display System at FTD. A phased procurement will minimize the risk exposure to the government and spread cost expenditures.
- A primary concern at the offset of the study was the ability of available display units to produce highly legible displays of microfiche documents. On the basis of actual simulation demonstrations, it has been concluded that the Tektronix Model #4014-1 Direct View Storage Display Terminal fully meets the demanding viewing requirements. The terminal was recommended based on an overall assessment including other analyses.
- A solid-state scanner was recommended as the microfiche digitizer based on an overall assessment of performance, cost, reliability and maintainability.
- The FTD microfiche data base contains a variety of textual documents of different quality levels and letter heights ranging down to about 0.025 inch. A system "zoom" capability is recommended so that a 2:1 magnification of the image size can be obtained at the display. This results in a doubling of the effective resolution so that the smallest symbol sizes can be clearly displayed.

- Although excellent results were obtained displaying "zoomed" images, the adverse effect of microfiche film density variations across extremely small characters and fine grid lines was evident. It is apparent that the legibility of these characters is affected by the threshold level used in digitizing the analog signal obtained from the microfiche scanner. It is recommended that the thresholding problem should be studied and circuitry developed in order to optimize the legibility of poor quality microfiche originals containing excessive density variations.
- It has been concluded that data compression is not required. Two advantages one would expect to obtain from data compression are lower storage equipment needs and faster transmission rates. While the storage needs can be decreased, nothing is gained in the area of data transmission speed. Furthermore, increased cost, complexity of equipment, and susceptibility to errors make data compression undesirable.
- No attempt will be made to check for errors or correct transmitted pictorial data. The conclusion is that error detection is unnecessary. Image data, by its very nature contains a large amount of redundancy and thus can accommodate many errors. In addition, the coaxial cable system being used for data transmission provides a reasonably noise-free medium.

APPENDIX A

MICROFICHE SCANNER PERFORMANCE AND PARAMETRIC ANALYSES

A.0 INTRODUCTION

In the analysis of the candidate scanners, analytical models of the scanners were generated. These models predict the performance (output signal-to-noise ratio) of the scanners as a function of the spatial frequency at the microfiche plane. In this Appendix, these models are developed.

A.1 MODULATION TRANSFER FUNCTIONS

The modulation transfer function of a scanner describes the ability of the scanner to reproduce an input sine wave. The MTF is defined as the amplitude response of the system. The overall scanner MTF, designated as $\tau_s(K)$ is the ratio, as a function of spatial frequency, of the modulation in the output signal to that in the input.

$$\text{i.e.} \quad \tau_s(K) = \frac{M_o(K)}{M_i} \quad (\text{A-1})$$

where,

K = the spatial frequency

M_i = the modulation of the input

$M_o(K)$ = the modulation of the output signal

In the case of the microfiche scanner, the input modulation, M_i , can be defined in terms of the contrast ratio, C_R , of the fiche

$$M_i = \frac{C_R - 1}{C_R + 1} \quad (\text{A-2})$$

In the analytical models of the scanners, the input signal, S_i , is expressed in terms of the difference in transmitted light intensity through the fiche

$$\text{i.e. } S_i = \Delta E = E_{\max} - E_{\min} \quad (\text{A-3})$$

where,

E_{\max} = the maximum intensity through the fiche

E_{\min} = the minimum intensity through the fiche

Since the contrast ratio is defined as E_{\max}/E_{\min} , the signal can be expressed as

$$S_i = E_{\min} (C_R - 1) \quad (\text{A-4})$$

The average intensity, \bar{E} , through the fiche can be defined as

$$\bar{E} = \frac{E_{\max} + E_{\min}}{2} \quad (\text{A-5})$$

or, in terms of the contrast ratio, C_R ,

$$\bar{E} = \frac{E_{\min} (C_R + 1)}{2} \quad (\text{A-6})$$

Solving equation (A-6) for E_{\min} and substituting that expression back into equation (A-4), equation (A-4) becomes

$$S_i = 2 \left(\frac{C_R - 1}{C_R + 1} \right) \bar{E} \quad (\text{A-7})$$

or,

$$S_i = 2 M_1 \bar{E} \quad (\text{A-8})$$

When the entire scanner is considered, the input signal is transferred and affected by many individual components. Each of these components has a unique MTF. Consequently, the processes that convert the average light intensity through the fiche (\bar{E}) to an average output electrical current (I_o) also reduces the modulation of the input signal. Therefore, the output signal of the scanner $S_o(K)$ is given by

$$S_o(K) = 2 M_o(K) I_o \quad (A-9)$$

$$= 2 M_1 \tau_s(K) I_o \quad (A-10)$$

Equation (A-10) has been used in the development of the signal expression of all the scanner analytical models presented below.

A.1.1 COMPONENT MODULATION TRANSFER FUNCTIONS

The response of the overall scanner is the product of the responses of all of the components of the scanner. The purpose of this section is to present a general description of the component MTF's and identify which MTF's are associated with each scanner.

A.1.1.1 MTF of Lens. In modeling the various scanners, the lenses selected were assumed to be diffraction limited. Aberration-limited lenses were not considered.

The MTF of a perfect diffraction-limited lens is

$$\tau_L(K) = \frac{2}{\pi} \left[\cos^{-1} \left(\frac{\pi K}{b} \right) - \frac{\pi K}{b} \sqrt{1 - \left(\frac{\pi K}{b} \right)^2} \right] \quad (A-11)$$

where,

$$b = \frac{\pi D}{F\lambda}$$

λ = the wavelength

D = lens aperture diameter

F = focal length of lens

A.1.1.2 MTF of Electron Beam. The MTF of an electron beam can be calculated assuming the beam spot has a Gaussian shape. The MTF is obtained by taking the Fourier transform of the Gaussian distribution. The result is

$$\tau_R(K) = e^{-2\pi^2 K^2 \sigma^2} \quad (A-12)$$

where, σ = standard deviation of the Gaussian distribution

In this study, σ , is taken to be one-fourth of the spot diameter; where the spot diameter is defined as the full width of the Gaussian distribution between the 5% amplitude points

A.1.1.3 MTF of Dissecting Aperture. When an aperture is used to "sample" the signal, the modulation of the sampled signal is reduced. If the aperture is circular, as in the case of the image dissector considered in this study, the MTF describing the reduction in modulation is the following:

$$\tau_{ap}(K) = \frac{2J_1(\pi D_a K)}{\pi D_a K} \quad (A-13)$$

where,

J_1 is a Bessel function

D_a = aperture diameter

A.1.1.4 MTF of Solid State Line Array. The MTF associated with the solid state array is principally the result of the finite size and spacing of the sensing elements.

For an element width, d , and assuming no dead space between the elements, the modulation transfer function takes the form

$$\tau_a(K) = \frac{\sin(\pi K d)}{\pi K d} \quad (A-14)$$

A.1.1.5 Image Motion MTF. One possible approach to scanning a fiche page using a solid state line array requires that the fiche be moved at a constant velocity along the page length. This motion results in a loss in response along the direction of motion. In terms of an MTF, this loss in response can be expressed as

$$\tau_{IM}(K) = \frac{\sin(\pi A_m K)}{\pi A_m K} \quad (A-15)$$

where, A_m = the magnitude of the image motion at the surface of the array during the integration time.

A.1.1.6 Image Section, Camera Target and Readout Section MTF's. Modulation transfer functions can be derived for image sections, camera targets and readout sections. However, such expressions can become quite complex. In addition, assigning numerical values to some of the terms contained in these expressions is frequently quite difficult. Consequently, when possible, experimental MTF data from various manufacturers is used in place of analytically derived MTF's for these components.

A1.1.7 Scanner MTF's. The MTF's used in the analytical models of each scanner is a function of the particular scanner being modeled. Table A-1 below shows which of the component MTF's discussed above are associated with each of the scanners being analyzed.

TABLE A-1
COMPONENT MTF's FOR SCANNERS

	Image Dissector	Flying Spot	Vidicon Camera	Laser	Solid State
Input (contract) modulation	X	X	X	X	X
MTF of lens	X	X	X	X	X
MTF of electron beam		X			
MTF of dissecting aperture	X				
MTF of solid state line array					X
MTF due to image motion					X
MTF of image section	X				
MTF of camera target			X		
MTF of readout section			X		

A.2 DEVELOPMENT OF ANALYTICAL PEAK SIGNAL-TO-RMS NOISE MODELS

Presented below is the development of the analytical models of the candidate scanners described in Section 3.1.

A.2.1 ANALYTICAL PEAK SIGNAL-TO-RMS NOISE MODEL FOR THE IMAGE DISSECTOR SCANNING SYSTEM

The image dissector scanning system is described in Section 3.1.1.1 of this report. To summarize, a page of the fiche is imaged onto the image dissector photocathode. The resulting photoelectron image is scanned across an aperture. Those electrons passing through the aperture enter an electron multiplier. The amplified signal is then fed into the preamp and subsequently into other signal processing electronics.

A.2.1.1 Output Signal Current. In this section, a mathematical expression for the output signal current associated with the image dissector scanning system is derived.

For an illumination level behind the fiche of, E , (watts/cm²), the average illumination, \bar{E} , in front of the fiche is to be calculated by the equation:

$$\bar{E} = E \left(\frac{C_R + 1}{2C_R} \right) \quad (\text{A-16})$$

where, C_R = the contrast ratio of the fiche

The corresponding average illumination \bar{E}' at the image dissector photocathode is given by the expression:

$$\bar{E}' = \frac{\bar{E} \tau_L}{4f^2 (M + 1)^2} \quad (\text{watts/cm}^2) \quad (\text{A-17})$$

where,

$f = \# / f$ of the lens

$M =$ magnification of the lens

$t_L =$ transmission of the lens

The illumination E has, however, spectral characteristics. These characteristics become important in determining the magnitude of the output current resulting from this illumination. Consequently, E will be replaced by the expression:

$$E \rightarrow W_p \int_0^\infty W_\lambda d\lambda$$

where,

$W_p =$ peak spectral power (watts/nm)

$W_\lambda =$ relative spectral power

$\lambda =$ wavelength (nm)

thus,

$$\bar{E} = \frac{(C_R + 1) W_p t_L \int_0^\infty W_\lambda d\lambda}{8 C_R f^2 (M + 1)^2} \quad (\text{watts/cm}^2) \quad (\text{A-18})$$

The average current density emitted from the dissector photocathode, I_c , is:

$$I_c = \frac{(C_R + 1) W_p S_p t_L \int_0^\infty W_\lambda \sigma_\lambda d\lambda}{8 C_R f^2 (M + 1)^2} \quad (\text{amps/cm}^2) \quad (\text{A-19})$$

where,

$S_p =$ peak spectral sensitivity of the photocathode (amps/watt).

$\sigma_\lambda =$ relative spectral sensitivity of the photocathode

The corresponding current, I_a , through the dissecting aperture having an area A_a is:

$$I_a = A_a I_c \quad (\text{amps}) \quad (\text{A-20})$$

This current enters an electron multiplier having a gain G_m . Thus, the average current, I_o , out of the scanner is given by the expression:

$$I_o = G_m A I_c \quad (\text{amps}) \quad (\text{A-21})$$

As concluded in Section A.1, the output signal, $S_o(K)$, corresponding to an output current, I_o , is:

$$S_o(K) = 2M_i \tau_s(K) I_o \quad (\text{A-10})$$

$$= 2M_i \tau_s(K) G_m A I_c \quad (\text{A-22})$$

$$= \frac{M_i \tau_s (C_R + 1) G_m A W S t_o \int_{\lambda}^{\infty} W_{\lambda} \sigma_{\lambda} d\lambda}{4C_R f^2 (M+1)^2} \quad (\text{A-23})$$

From the chart presented in Section A.1.1.7, τ_s component responses comprising $\tau_s(K)$ are τ_L , τ_a and $\tau_{\text{image section}}$

i.e.
$$\tau_s(K) = \tau_L(K) \tau_a(K) \tau_{\text{image section}}(K) \quad (\text{A-24})$$

Thus, the completed output signal expression for the image dissector scanning system takes the form:

$$S_o(K) = \frac{M_i \tau_L \tau_a \tau_{is} (C_R + 1) G_m A W S t_o \int_{\lambda}^{\infty} W_{\lambda} \sigma_{\lambda} d\lambda}{4C_R f^2 (M+1)^2} \quad (\text{A-25})$$

where, τ_{is} = the response of the image section.

A.2.1.2 Output Noise Current. The noise sources associated with the image dissector scanning system are:

shot noise of the photoelectrons
 noise due to the electron multiplier
 thermal noise of the load impedance

A.2.1.2.1 Shot Noise of the Photoelectrons. As derived in Section A.2.1.1, the photoelectron current, I_a , passing through the dissecting aperture is:

$$I_a = A_a I_c = \frac{(C_R+1)A_a W_p S_p t_L \int_0^\infty W_\lambda \sigma_\lambda d\lambda}{8C_R f^2 (M+1)^2} \quad (A-26)$$

This current has a shot noise current, i_a , associated with it. This shot noise current is defined as:

$$i_a = (2eI_a \Delta f)^{1/2} \quad (A-27)$$

where,

Δf = video bandwidth

e = electronic charge

This noise current is amplified by the electron multiplier in the same way as the signal current.

Thus, the output noise, i_a , due to the photoelectrons can be expressed as:

$$i_a = G_m (2eI_a \Delta f)^{1/2} \quad (A-28)$$

$$= G_m \left[\frac{(C_R+1)e\Delta f A_a W_p S_p t_L \int_0^\infty W_\lambda \sigma_\lambda d\lambda}{4C_R f^2 (M+1)^2} \right]^{1/2} \quad (A-29)$$

A.2.1.2.2 Noise Due to the Electron Multiplier. The electron multiplier uses secondary electron emission from the dynodes to amplify the signal. This secondary electron emission process generates its own noise. This noise contribution is a function of the electron current entering the multiplier and also a function of the secondary emission ratio of the first dynode of the multiplier. Defining, i_m , as the noise current due to this secondary emission process, i'_m takes the form:

$$i'_m = \left[\frac{2eI_a \Delta f}{\delta_m - 1} \right]^{1/2} \quad (\text{A-30})$$

where, δ_m = secondary emission ratio of the first dynode.

As in the case of the photoelectron shot noise current, this current is amplified by the electron multiplier. Thus,

$$i'_m = G_m \left[\frac{2eI_a \Delta f}{\delta_m - 1} \right]^{1/2} \quad (\text{A-31})$$

$$= G_m \left[\frac{(C_R + 1) e \Delta f A_a W_p S_p t_L \int_0^\infty W_\lambda \sigma_\lambda d\lambda}{4C_R f^2 (\delta_m - 1) (M+1)^2} \right]^{1/2} \quad (\text{A-32})$$

where, i'_m = the output noise current corresponding to i_m .

A.2.1.2.3 Thermal Noise of the Load Impedance. The output "load" impedance has a thermal or "Johnson" noise associated with it. In terms of a noise current, i_t , this noise is defined by the expression:

$$i_t = \left[\frac{4kT\Delta f}{R_L} \right]^{1/2} \quad (\text{A-33})$$

where,

k = Boltzmann's constant

T = absolute temperature

R_L = load impedance

The average noise associated with the scanning system is assumed to be the RMS value of all the above noise currents.

The complete analytical peak signal-to-RMS noise expression for the image dissector scanning system is presented in Section A.3.

A.2.2 ANALYTICAL PEAK SIGNAL-TO-RMS NOISE MODEL FOR THE FLYING SPOT SCANNING SYSTEM

The flying spot scanner is described briefly in Section 3.1.1.2 of this report. Due to its simplicity of operation, its description will not be repeated here.

A.2.2.1 Output Signal Current. The output signal current of the flying spot scanner is a function of the intensity of the light on the face of the CRT. This intensity can be determined as follows:

For A CRT electron beam current, I_B , an anode voltage, V_a , and a dead voltage, V_d , (resulting from penetration of the conductive film in front of the phosphor), the power, P , delivered to the phosphor is given by the expression:

$$P = I_B(V_a - V_d) \quad (\text{watts}) \quad (\text{A-34})$$

The corresponding power density, P_D , delivered to the phosphor is

$$P_D = \frac{P}{A_B} = \frac{I_B(V_a - V_d)}{A_B} \quad (\text{watts/cm}^2) \quad (\text{A-35})$$

where,

A_B = area of the beam

The light intensity output, E_p , of the CRT resulting from P_D is given by the expression:

$$E_p = P_D L_p \int_0^\infty \phi_\lambda d\lambda = \quad (A-36)$$

$$= \frac{I_B (V_a - V_d) L_p \int_0^\infty \phi_\lambda d\lambda}{A_B} \quad (\text{watts/cm}^2) \quad (A-37)$$

where,

L_p = peak monochromatic output
of the phosphor (watts/watt/nm)

ϕ_λ = relative spectral output of the phosphor

At the plane of the microfiche, but before passing through the fiche, the light intensity, E'_p , is

$$E'_p = \frac{I_B (V_a - V_d) L_p t_{L1} \int_0^\infty \phi_\lambda d\lambda}{A_B (4f_1^2) (M_1 + 1)^2} \quad (\text{watts/cm}^2) \quad (A-38)$$

where,

t_{L1} = the transmission coefficient of the
demagnifying lens

f_1 = the #/f of the lens

M_1 = the demagnification ratio of the lens

Upon passing through the fiche, the average light intensity \bar{E}' is given by the expression:

$$\bar{E}'_p = \left[\frac{C_R + 1}{2C_R} \right] E'_p \quad (\text{watts/cm}^2) \quad (A-39)$$

In turn, the average total amount of light passing through the
fiche, \bar{P}' , is equal to:

$$\bar{P}' = \bar{E}'_p A_B M_1^2 \quad (\text{watts}) \quad (\text{A-40})$$

$$= \frac{(C_R+1)M_1^2 I_B (V_a - V_d) L_p t_p t_{L1} \int_0^\infty \phi_\lambda d\lambda}{8C_R f_1^2 (M_1+1)^2} \quad (\text{watts}) \quad (\text{A-41})$$

The majority of the light is collected by a second lens having a
transmission coefficient, t_{L2} .

Thus, the total light \bar{P}'' entering the photomultiplier is:

$$\bar{P}'' = \bar{P}' t_{L2} \quad (\text{watts}) \quad (\text{A-42})$$

This light results in a photoelectron current I_c , where

$$I_c = \frac{(C_R+1)M_1^2 I_B (V_a - V_d) L_p t_p t_{L1} t_{L2} S_p \int_0^\infty \phi_\lambda \sigma_\lambda d\lambda}{8C_R f_1^2 (M_1+1)^2} \quad (\text{amps}) \quad (\text{A-43})$$

S_p = peak spectral sensitivity of the PMT
photocathode (amps/watt)

σ_λ = relative spectral sensitivity of the photocathode

This current is amplified by the gain, G_m , of the electron multiplier
portion of the PMT. Thus, the average current, I_o , out of the scanner is given
by the expression:

$$I_o = G_m I_c \quad (\text{A-44})$$

The corresponding output signal $S_o(K)$ is thus,

$$S_o(K) = 2M_1 \tau_s(K) I_o \quad (A-45)$$

From the chart presented in Section A.1.1.7, the component responses comprising $\tau_s(K)$ are τ_{L_1} and τ_R .

i.e.
$$\tau_s(K) = \tau_{L_1}(K) \tau_R(K) \quad (A-46)$$

Thus, the completed output signal expression for the flying spot scanning system takes the form:

$$S_o(K) = \frac{M_1 \tau_{L_1} \tau_R (C_R + 1) G_m M_1^2 I_B (V_a - V_d) L_p t_p t_{L_1} t_{L_2} S_p \int_0^\infty \phi_\lambda \sigma_\lambda d\lambda}{4C_R f_1^2 (M_1 + 1)^2} \quad (\text{amps}) \quad (A-47)$$

A.2.2.2 Output Noise Current. The noise sources associated with the flying spot scanning system are:

- shot noise of the CRT electron beam
- shot noise of the PMT photoelectrons
- noise due to the electron multiplier
- thermal noise of the load impedance

A.2.2.2.1 Shot Noise of the CRT Electron Beam. The shot noise current, i_b , associated with the CRT electron beam is given by the expression:

$$i_b = (2eI_B \Delta f)^{1/2} \quad (A-48)$$

where, I_B = the electron beam current

The same method used to obtain an output current I_o corresponding to the electron beam current I_B is now used to obtain an output noise current i'_b corresponding to the CRT shot noise current i_b . This method leads to:

$$i'_b = \frac{G_m (C_R + 1) M_1^2 (2eI_B \Delta f)^{\frac{1}{2}} (V_a - V_d) L_p t_{L_1} t_{L_2} S_p \int_0^\infty \phi_\lambda \sigma_\lambda d\lambda}{8C_R f_1^2 (M_1 + 1)^2} \quad (\text{A-49})$$

A.2.2.2.2 Shot Noise of the PMT Photoelectrons. The photoelectron current, I_c , is defined by equation (A-43). The shot noise current, i_c , corresponding to I_c is defined as:

$$i_c = (2eI_c \Delta f)^{\frac{1}{2}} \quad (\text{A-50})$$

The noise current is, in turn, amplified by the gain of the electron multiplier. Thus, the output noise current, i'_c , due to the PMT photoelectrons is given by the expression:

$$i'_c = G_m i_c \quad (\text{A-51})$$

$$= G_m \left[\frac{(C_R + 1) e \Delta f M_1^2 I_B (V_a - V_d) L_p t_{L_1} t_{L_2} S_p \int_0^\infty \phi_\lambda \sigma_\lambda d\lambda}{4C_R f_1^2 (M_1 + 1)^2} \right]^{\frac{1}{2}} \quad (\text{A-52})$$

A.2.2.2.3 Noise Due to the Electron Multiplier. As in Section A.2.1.2.2, the noise current, i_m , due to the electron multiplier is given by the expression,

$$i_m = \left[\frac{2eI_c \Delta f}{\delta_m - 1} \right]^{\frac{1}{2}} \quad (\text{A-53})$$

where, I_a , in the case of the image dissector is equivalent to, I_c , in the case of the flying spot scanner. This noise current is also amplified by the electron multiplier. The output noise current, i'_m , corresponding to i_m , is, therefore, $G_m i_m$, or,

$$i'_m = G_m \left[\frac{(C_R + 1) e \Delta f M_1^2 I_B (V_a - V_d) L_p t_{L_1} t_{L_2} S_p \int_0^\infty \phi_\lambda \sigma_\lambda d\lambda}{4 C_{R1}^2 (\delta_m - 1) (M_1 + 1)^2} \right]^{1/2} \quad (A-54)$$

A.2.2.2.4 Preamp Noise. The expression for the thermal noise of the load impedance is the same as in the case of the image dissector scanning system (Sections A.2.1.2.3 and A.2.1.2.4).

The complete analytical peak signal-to-RMS noise expression for the flying spot scanning system is presented in Section A.3.

A.2.3 ANALYTICAL PEAK SIGNAL-TO-RMS NOISE MODEL FOR THE VIDICON CAMERA SCANNING SYSTEM

The vidicon camera scanning system is described in Section 3.1.3.1 of this report. To summarize here, a page on the fiche is focussed onto the uniformly charged photoconductive target. Each element of the target is discharged an amount proportional to the amount of light striking that element. An output electrical signal corresponding to the input image is obtained by replacing the charge removed from each element. This is achieved by scanning the target with a low energy electron beam.

A.2.3.1 Output Signal Current. The average light illumination \bar{E}' at the photoconductive target can be derived in a manner identical to that used in Section A.2.1.1. That is, for an illumination level behind the fiche of $E = W_p \int_0^\infty W_\lambda d\lambda$ watts/cm², \bar{E}' at the photoconductive target is given by the expression:

$$\bar{E}' = \frac{(C_R + 1) W_p t_L \int_0^\infty W_\lambda d\lambda}{8 C_R f^2 (M + 1)^2} \quad (\text{watts/cm}^2) \quad (\text{A-18})$$

Expressed in terms of photons (or "quanta") per cm² per sec,

$$\bar{E}' \rightarrow \bar{E}'_q = \frac{(C_R + 1) W_p t_L \int_0^\infty \lambda W_\lambda d\lambda}{8 h c C_R f^2 (M + 1)^2} \quad (\text{photons/cm}^2\text{-sec}) \quad (\text{A-55})$$

where,

h = Plank's constant

c = speed of light

For an exposure (or integration) time of, T_e , and a resolution element on the target of area, A , the number of photons, N_p , striking a resolution element is

$$\bar{E}'_q T_e A = \frac{AT_e (C_R + 1) W_p t_L \int_0^\infty \lambda W_\lambda d\lambda}{8hcC_R f^2 (M+1)^2} \quad (\text{photons/res. ele.}) \quad (\text{A-56})$$

The quantum efficiency, η_λ , of the target is defined as the average number of electrons released within the photoconductor for every incoming photon. The value of, η_λ , is a function of the wavelength of the incoming light. Thus, for, N_p , photons striking a resolution element, that resolution element is discharged by an amount, ΔQ ,

$$\text{where,} \quad \Delta Q = \frac{eAT_e (C_R + 1) W_p t_L \int_0^\infty \lambda \eta_\lambda W_\lambda d\lambda}{8hcC_R f^2 (M+1)^2} \quad (\text{couls/res. ele.}) \quad (\text{A-57})$$

(e = electronic charge)

During readout, a fraction, n_c , of this charge is replaced in a time Δt , where Δt is approximately equal to $\frac{1}{2\Delta f}$ (Δf = video bandwidth).

The output current, I_o , generated in the target circuit by this readout process is, therefore, given by the equation:

$$I_o = \frac{n_c \Delta Q}{\Delta t} = 2n_c \Delta f \Delta Q \quad (\text{amps}) \quad (\text{A-58})$$

The corresponding output signal $S_o(K)$ is equal to:

$$2M_i \tau_s(K) I_o \quad (\text{amps}) \quad (\text{A-59})$$

From the chart presented in Section A.1.1.7, the component responses comprising $\tau_s(K)$ for the vidicon camera are τ_L , τ_{target} and $\tau_{\text{readout section}}$

i.e.,
$$\tau_s(K) = \tau_L(K) \tau_t(K) \tau_{rs}(K)$$

where, $\tau_t(K)$ = response of the target

$\tau_{rs}(K)$ = response of the readout section

Thus, the completed output signal expression for the vidicon camera scanning system takes the form:

$$S_o(K) = \frac{M_i \tau_L \tau_t \tau_{rs} (C_R + 1) n_c \Delta f e A T W_e p L_o \int_0^\infty \lambda \eta_\lambda W_\lambda d\lambda}{2hc C_R f^2 (M+1)^2} \quad (\text{amps}) \quad (\text{A-60})$$

A.2.3.2 Output Noise Current. The noise sources associated with the vidicon camera scanning system are:

Quantum noise

Noise due to the photoconductive target

Shot noise due to the read beam

Shot noise due to the target dark current

Preamp (load impedance) noise

A.2.3.2.1 Quantum (Image) and Target Noise. The average number of photons striking a resolution element is, N_p , and is defined by equation A-56. Assuming Poisson statistics, the RMS fluctuation in this number of photons is the noise associated with the input image.

In addition, the photoconductive target contributes its own noise to the signal. If the assumption is made that the randomness of the "photon-to-electron" process is best described in terms of a Poisson distribution, then this noise contribution can be taken into account by "multiplying" the image noise by the factor, F_g ,

where,
$$F_g \approx \left(\frac{\eta_\lambda + 1}{\eta_\lambda} \right)^{\frac{1}{2}} \quad (\text{A-61})$$

Thus, in terms of corresponding noise electrons, n_e , per resolution element:

$$n_e = \eta_\lambda \left[\left(\frac{\eta_\lambda + 1}{\eta_\lambda} \right) N_p \right]^{\frac{1}{2}} \quad (\text{A-62})$$

$$= \left[\eta_\lambda (\eta_\lambda + 1) N_p \right]^{\frac{1}{2}} \quad (\text{electrons/res. ele.}) \quad (\text{A-63})$$

However, recognizing the wavelength dependence of η_λ , n_e must really be expressed as:

$$n_e = \left[\frac{AT_e (C_R + 1) W_p t_L \int_0^\infty \lambda \eta_\lambda (\eta_\lambda + 1) W_\lambda d\lambda}{8hcC_R f^2 (M+1)^2} \right]^{\frac{1}{2}} \quad (\text{electrons/res. ele.}) \quad (\text{A-64})$$

The equivalent noise charge, q_e , in terms of couls/res. ele. is $e(n_e)$.

This noise charge is transferred out of the scanner in the same manner as is the signal charge, ΔQ . Thus, the output noise current, i_{qn} resulting from the input quantum noise is:

$$i_{qn} = \frac{n q_e}{\Delta t} = 2en_c \Delta f n_e \quad (\text{A-65})$$

$$= \left[\frac{e^2 n_c^2 \Delta f^2 A T_e (C_R + 1) W_p t_L \int_0^\infty \lambda \eta_\lambda (n_\lambda + 1) W_\lambda d\lambda}{2hcC_R f^2 (M+1)^2} \right]^{1/2} \quad (\text{amps}) \quad (\text{A-66})$$

A.2.3.2.2 Shot Noise Due to the Read Beam. The expression for the current, I_o , generated in the target (output) circuit by the read process is obtained by substituting the expression for, ΔQ , in equation A-57 into equation A-58. This "charge replacement" current, originating from the read electron gun, has a shot noise component given by the expression:

$$i_r = (2eI_o \Delta f)^{1/2} \quad (\text{A-67})$$

where, i_r = the shot noise due to the read beam.

By combining equations A-57, A-58 and A-67, the shot noise in the read beam can be expressed as:

$$i_r = \left[\frac{e^2 \Delta f^2 n_c A T_e (C_R + 1) W_p t_L \int_0^\infty \lambda \eta_\lambda W_\lambda d\lambda}{2hcC_R f^2 (M+1)^2} \right]^{1/2} \quad (\text{A-68})$$

A.2.3.2.3 Shot Noise Due to the Target Dark Current. During the read process, a second current, I_d , is observed in the output. This "dark current" is the result of leakage in the target. While this current does not contribute to the output signal, it does contribute to the noise in the signal. Its noise current, i_d , is equal to $(2eI_d\Delta f)^{\frac{1}{2}}$.

A.2.3.2.4 Preamp Noise. The expression for the thermal noise of the load impedance is the same as in the case of the image dissector scanning system discussed above. The complete analytical peak signal-to-RMS noise expression for the vidicon camera scanning system is presented in Section A.3.

A.2.4 ANALYTICAL PEAK SIGNAL-TO-RMS NOISE MODEL FOR THE LASER SCANNING SYSTEM

The laser scanning system is described in Section 3.1.1.4. While the method used to generate a scanning spot is different from that used in the flying spot scanner, the approach used to generate an output signal from the fiche is basically the same.

A.2.4.1 Output Signal Current. The light from the laser is inherently collimated. Thus, the development of the analytical model for the laser scanner takes a slightly different form from the cases where diffuse light is used to illuminate the fiche.

If, P , is the output power of the laser, the light power, P' , at the back surface of the fiche is given by the expression:

$$P' = t_{so} t_{sp} t_{L_1} P \quad (\text{watts}) \quad (\text{A-69})$$

where,

t_{so} = transmission of the beam shaping optics

t_{sp} = transmission of the spinner

t_{L_1} = transmission of the objective lens

In front of the fiche, the average light power \bar{P}' is equal to:

$$\left(\frac{C_R+1}{2C_R}\right) \bar{P}' = \frac{(C_R+1)t_{so}t_{sp}t_{L_1}P}{2C_R} \quad (\text{watts}) \quad (\text{A-70})$$

This power corresponds to an average power \bar{P}'' at the face of the PMT,

where,

$$\bar{P}'' = \frac{(C_R+1)t_{so}t_{sp}t_{L_1}t_{L_2}P}{2C_R} \quad (\text{watts}) \quad (\text{A-71})$$

(t_{L_2} = transmission of the collecting lens)

\bar{P}'' results in an average PMT photocathode current, I_c . This current is defined by the expression:

$$I_c = S_p \sigma_\lambda^* \bar{P}'' = \frac{(C_R+1)S_p \sigma_\lambda^* t_{so}t_{sp}t_{L_1}t_{L_2}P}{2C_R} \quad (\text{amps}) \quad (\text{A-72})$$

where, S_p = peak spectral sensitivity of the PMT photocathode (amps/watt)

σ_λ^* = relative spectral response of the photocathode at the wavelength of the incoming light

The corresponding PMT output current, I_o , is equal to:

$$G_m S_p \sigma_\lambda^* \bar{P}'' \quad (\text{amps}) \quad (\text{A-73})$$

where, G_m = the gain of the multiplier

The output signal, $S_o(K)$, is, therefore, given by the expression:

$$S_o(K) = 2M_i \tau_s(K) G_m S_p \sigma_\lambda^* P \quad (\text{amps}) \quad (\text{A-74})$$

where, from the table in Section A.1.1.7,

$$\tau_s(K) = \tau_L(K) \quad (\text{A-75})$$

Thus, the completed signal expression takes the form:

$$S_o(K) = \frac{M_i \tau_L (C_R + 1) G_m S_p \sigma_\lambda^* t_{so} t_{sp} t_{L_1} t_{L_2} P}{C_R} \quad (\text{amps}) \quad (\text{A-76})$$

A.2.4.2 Output Noise Current. The noise sources associated with the laser scanning system are:

Shot noise of PMT photoelectrons

Laser noise

Noise due to electron multiplier

Preamp noise

A.2.4.2.1 Shot Noise of PMT Photoelectrons and Laser Noise. The photoelectron current, I_c , is defined by equation A-72. The shot noise current, i_c , corresponding to, I_c , is defined as:

$$i_c = (2eI_c \Delta f)^{1/2} \quad (\text{A-50})$$

However, the laser, itself, contributes a substantial amount of noise to the photoelectron current, I_c . For this analysis, the laser noise contribution will be taken into account by multiplying, i_c , by a noise factor, κ . Thus, the total noise current, i_{cl} , in the photoelectron current, I_c , is defined as:

$$i_{cl} = \kappa(2eI_c \Delta f)^{\frac{1}{2}} \quad (A-77)$$

This noise current, in turn, is amplified by the gain of the electron multiplier. Thus, the output noise current, i'_{cl} due to the PMT photoelectrons and the laser itself is given by the expression:

$$i'_{cl} = G_m i_{cl} = G_m \kappa \left[\frac{e\Delta f(C_R+1)S_p \sigma_{\lambda}^* t_{so} t_{sp} t_{L_1} t_{L_2} P}{C_R} \right]^{\frac{1}{2}} \quad (A-78)$$

A.2.4.2.2 Noise Due to Electron Multiplier. The noise current, i_m , due to the electron multiplier has already been discussed in other sections and is defined by equation A-53. Recognizing that this noise current is amplified by the gain of the multiplier and substituting the right side of equation A-72 for, I_c , results in the following expression for the output noise current i'_m due to the electron multiplier.

$$i'_m = G_m \left[\frac{e\Delta f(C_R+1)S_p \sigma_{\lambda}^* t_{so} t_{sp} t_{L_1} t_{L_2} P}{C_R(\delta_m-1)} \right]^{\frac{1}{2}} \quad (A-79)$$

A.2.4.2.3 Preamp Noise. The expressions for the thermal noise of the load impedance is the same as in the cases of the other scanning systems discussed above.

The complete analytical peak signal-to-RMS noise expression for the laser scanning system is presented in Section A.3 .

A.2.5 ANALYTICAL PEAK SIGNAL-TO-RMS NOISE MODEL FOR THE SOLID STATE SCANNING SYSTEM

The solid state scanning system is described in Section 3.1.1.5. While the method used in "reading out" the signal differs from that used in the vidicon camera system, the signal transfer mechanisms of the two systems are basically the same. In addition, the principle noise sources associated with the two systems are the same.

A.2.5.1 Output Signal Current. The output signal for the solid state scanning system is derived in the same way as was the output signal for the vidicon camera system. In the case of the solid state system, however, the entire signal stored in each element of the array is read out (i.e. $n_c = 1$). Thus, combining equation A-57 and A-58 and setting $n_c = 1$, the average current, I_o , out of the array is given by the equation:

$$I_o = \frac{\Delta f e A T_e (C_R + 1) W_p t_L \int_0^\infty \lambda \eta_\lambda W_\lambda d\lambda}{4 h c C_R f^2 (M+1)^2} \quad (\text{amps}) \quad (\text{A-80})$$

From the chart presented in Section A.1.1.7, the component responses comprising $\tau_g(K)$ for the solid state scanning system are τ_L , τ_a and τ_{IM} .

The output signal, $S_o(K)$, is, therefore, equal to:

$$2M_i \tau_L \tau_a \tau_{IM} I_o$$

or,

$$S_o(K) = \frac{M_i \tau_L \tau_a \tau_{IM} (C_R + 1) \Delta f e A T W_p t_o \int_0^\infty \lambda \eta_\lambda W_\lambda d\lambda}{2hc C_R f^2 (M+1)^2} \quad (\text{amps}) \quad (\text{A-81})$$

A.2.5.2 Output Noise Current. The noise sources that will be considered here are those associated with the photodiode (Reticon) array. They are:

Quantum noise

Noise due to the photoconductive array

Shot noise associated with the charge replacement (readout) process

Shot noise due to the array dark current

Preamp noise

The analysis used in obtaining expressions for each of the above noise terms is identical to that used in deriving the expressions for the noise terms associated with the vidicon camera scanning system. In fact, the expressions for the total noise current associated with the photodiode array and the vidicon camera are the same provided, n_c , is set equal to "1" in the photodiode array case.

The complete analytical peak signal-to-RMS noise expression for the photodiode linear array scanning system is presented in Section A.3 .

A.3 ANALYTICAL PEAK-SIGNAL-TO-RMS NOISE MODELS FOR CANDIDATE SENSORS

The analytical peak-signal-to-RMS-noise models developed for the candidate scanners are presented in Equations (A-82) through (A-85).

IMAGE DISSECTOR SCANNING SYSTEM

$$\frac{M_1 I_1 I_2 (C_R + 1) G_A H S t_p L_1 \sigma_\lambda d\lambda}{4C_R f^2 (M+1)^2}$$

(A-82)

$$\frac{S}{N} = \left[\frac{4kT\Delta f}{R_L} + \frac{G_m^2 (C_R + 1) \omega \Delta E A W S t_p L_1 \sigma_\lambda d\lambda}{4C_R f^2 (S_m - 1) (M+1)^2} \right]^{1/2} + \frac{G_m^2 (C_R + 1) \omega \Delta E A W S t_p L_1 \sigma_\lambda d\lambda}{4C_R f^2 (M+1)^2} \Bigg]^{1/2}$$

Load Impedance Thermal Noise

Electron Multiplier Noise

PMT Photoelectron Shot Noise

FLYING SPOT SCANNING SYSTEM

$$\frac{M_1 I_1 I_2 (C_R + 1) G_M I_B (V_e - V_d) L_1 t_p L_2 t_s s_p \sigma_\lambda d\lambda}{4C_R f_1^2 (M_1 + 1)^2}$$

(A-83)

$$\frac{S}{N} = \left\{ \frac{4kT\Delta f}{R_L} + \frac{G_m^2 (C_R + 1) \omega \Delta E A W S t_p L_1 t_s s_p \sigma_\lambda d\lambda}{4C_R f_1^2 (S_m - 1) (M_1 + 1)^2} + \frac{G_m^2 (C_R + 1) \omega \Delta E A W S t_p L_1 t_s s_p \sigma_\lambda d\lambda}{4C_R f_1^2 (M_1 + 1)^2} + \frac{G_m (C_R + 1) M_1^2 (V_e - V_d) L_1 t_p L_2 t_s s_p \sigma_\lambda d\lambda}{8C_R f_1^2 (M_1 + 1)^2} \right\}^{1/2}$$

Load Impedance Thermal Noise

Electron Multiplier Noise

PMT Photoelectron Shot Noise

CRT Electron Beam Shot Noise

VIDICON CAMERA AND PHOTODIODE ARRAY SCANNING SYSTEMS

(A-84)

$$\frac{M_{1s}(C_R+1)n_e \Delta f e A T W_{pL} \int \dots \lambda n_{\lambda} W_{\lambda} d\lambda}{Z h c C_R f^2 (M+1)^2}$$

$$\frac{1}{2} \left[\frac{4kT\Delta f}{h\nu_L} + 2eI_d \Delta f + \frac{e^2 \Delta f^2 n_e A T_e (C_R+1) W_{pL} \int \dots \lambda n_{\lambda} W_{\lambda} d\lambda}{Z h c C_R f^2 (M+1)^2} + \frac{e^2 n_c^2 \Delta f^2 A T_e (C_R+1) W_{pL} \int \dots \lambda n_{\lambda} (n_{\lambda}+1) W_{\lambda} d\lambda}{Z h c C_R f^2 (M+1)^2} \right]^{1/2}$$

- Load Impedance Thermal Noise
- Target Dark Current Shot Noise
- Readout Current Shot Noise
- Quantum and Target Noise
- For Photodiode Array
- For Vidicon Camera
- $\gamma_n = \gamma_{Ls} \gamma_{IM}$
- $n_c = 1$

LASER SCANNING SYSTEM

(A-85)

$$\frac{M_{1L}(C_R+1)C_{sp} \lambda_{sp} t_{sp} t_{L1}^2}{C_R}$$

$$\frac{1}{2} \left[\frac{4kT\Delta f}{h\nu_L} + \frac{C_{sp}^2 e^2 \Delta f^2 (C_R+1) S_{p0} t_{sp} t_{L1}^2}{C_R (S-1)} + \frac{C_{sp}^2 e^2 \Delta f^2 (C_R+1) S_{p0} t_{sp} t_{L1}^2}{C_R} \right]^{1/2}$$

- Load Impedance Thermal Noise
- Electron Multiplier Noise
- PMT Photocathode Shot Noise and Laser Noise

A.4 RELATIONSHIP BETWEEN SCANNER SIGNAL-TO-NOISE RATIO AND OVERALL SCANNER-DISPLAY PERFORMANCE

Sections A.1 and A.2 of this appendix have presented in detail the development of the scanner signal-to-noise models. In scanner-display systems where the analog signal from the scanner is fed directly into the display, the scanner output signal-to-noise ratio (SNR) would have a direct affect on the quality (resolution and legibility) of the reconstructed image on the display. However, in the proposed Microfiche Scanner and Remote Display System, the scanner signal will be digitized. That is, the signal from each picture element will be characterized as either black (0) or white (1). This information will, in turn, be stored in the computer. Thus, the consideration here is that the SNR is large enough such that all of the picture elements are correctly digitized.

The analysis presented below will show that a SNR of 20:1 at the 130 lp/mm operating resolution is more than sufficient to insure 100% accurate digitization.

A.4.1 ANALYSIS RELATING SNR TO DIGITIZATION ACCURACY

The scanner signal-to-noise equations were developed using the assumption that the incoming signal and all the signal transfer mechanisms have a random nature associated with them. Consequently, the signals (input and output) can be described by Poisson statistics. That is, during a given sampling period, the input light levels (E_{\min} and E_{\max}) and the corresponding output current levels (I_{\min} and I_{\max}) have certain probabilities of

having certain values. These probabilities follow Poisson distributions. Each distribution curve has its peak at the nominal minimum and maximum levels. Figure A-1 presents this signal-probability concept graphically.

By definition, the noise associated with such a signal is equal to the standard deviation, σ , of a similar probability distribution having its peak value at the nominal \bar{E} (E average) or \bar{I} level. In the case where the maximum signal level is not much greater than the minimum signal level, the σ 's associated with each of the three distributions are approximately the same.

In terms of output SNR, the output signal current is defined as $I_{\max} - I_{\min}$ (where I_{\max} and I_{\min} are taken as their "nominal values"). Since the output noise is defined as σ ,

$$\frac{S}{N} = \frac{I_{\max} - I_{\min}}{\sigma} \quad (\text{A-86})$$

or,
$$\left(\frac{S}{N}\right)\sigma = I_{\max} - I_{\min} \quad (\text{A-87})$$

These relationships are also shown in Figure A-1.

In digitizing the output current, a threshold level is selected, typically at \bar{I} . Current levels above this threshold are digitized as "white" while current levels below this threshold are digitized as "black". However, it can be seen from Figure A-1 that sampled current levels in the I_{\min} distribution that fall above this threshold will be incorrectly digitized. Similarly, sampled current levels in the I_{\max} distribution that fall below this threshold will be incorrectly digitized. The probability of each of these

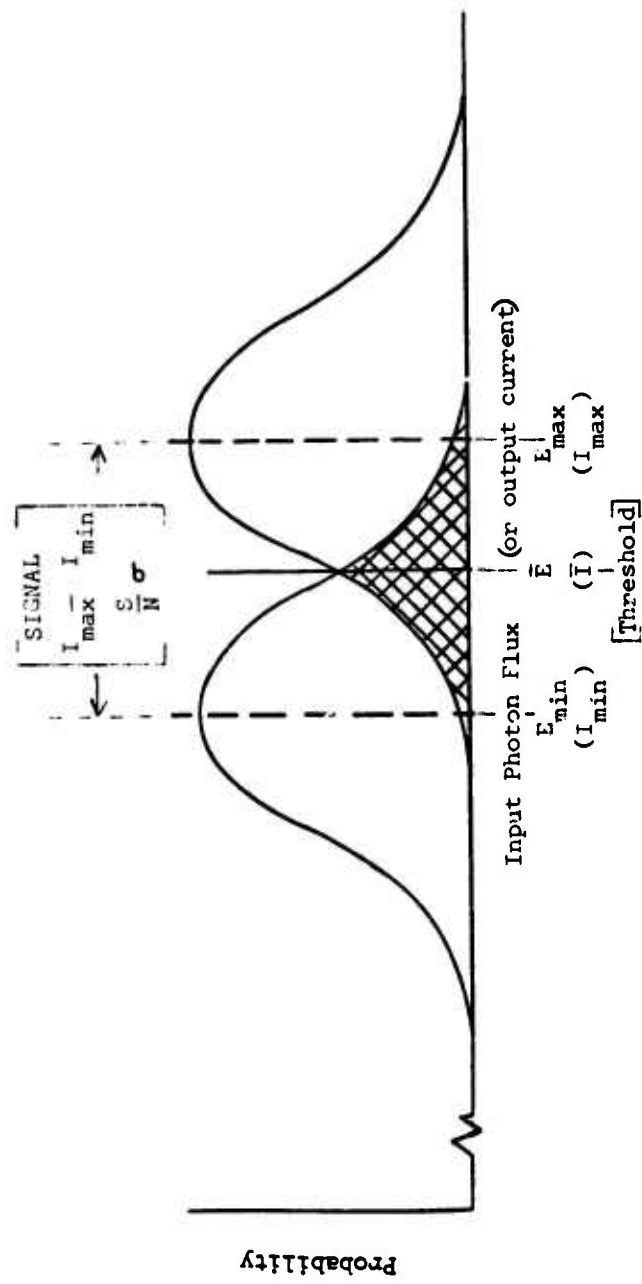

SIGNAL - PROBABILITY CONCEPT

FIGURE A-1

conditions occurring is equal to the shaded area in Figure A-1, (assuming that the probability distributions are normalized). Obviously, it is desirable to keep this probability very low. Analyses shows that this probability is of the order of 1×10^{-6} for a 10σ spread between the two distribution curves. Expressed in other terms, this probability is of the order of 1×10^{-6} for a signal-to-noise ratio of 10:1.

In the case of the proposed Microfiche Scanner and Remote Display System, a page on the fiche will be converted into approximately $7 \times 10^{+6}$ "black" or "white" picture elements. Thus, for the error probability of 1×10^{-6} , an average of only 7 of the $7 \times 10^{+6}$ picture elements will be incorrectly digitized.

A.4.2 CONCLUSION

The above analysis shows that scanners exhibiting an output signal-to-noise ratio of 10:1 or greater at the 130 lp/mm operating resolution can be considered as candidate scanners for this application. However, in order to realize a certain "margin of safety", a minimum signal-to-noise ratio of 20:1 at 130 lp/mm has been selected as a performance specification for the microfiche scanner.

APPENDIX B
SIMULATION EXPERIMENTS

B.0 INTRODUCTION

During the performance of the Microfiche Scanner and Remote Display System study, a number of simulation experiments were conducted to evaluate candidate display devices. Typical microfiche from the FTD data base were scanned and displayed on both non-storage cathode ray tube and direct view storage CRT devices. The simulation experiments, which in part were demonstrated for government personnel, were invaluable in validating the performance and selection of the Tektronix #4014 for the Microfiche System. The details of the tests that were performed and the results obtained are presented in this appendix.

B.1 SIMULATION EXPERIMENTS WITH LIPS AND STORAGE DISPLAY

A number of experiments were conducted during the study to investigate the feasibility of using a direct view storage terminal to display microfiche images. Initial experiments were conducted using a Laser Image Processing Scanner to scan the microfiche images and a Tektronix Model #613 storage display monitor with a 8-1/2" x 6-1/2" screen to display half page images. Results using the available display were of sufficient quality to justify extending the experimental tests to full page displays on a Tektronix Model #4014 Display Terminal. In addition to having a larger screen (11" x 15" display), this terminal has a higher spatial resolution than the older #613 monitor and also has a built-in keyboard.

The results obtained with the Tektronix #4014 Display Terminal were of high quality. Coupled with the results of other trade-off analyses conducted during the study, the experiments helped justify the selection of the terminal for use in the Microfiche Scanner and Remote Display System.

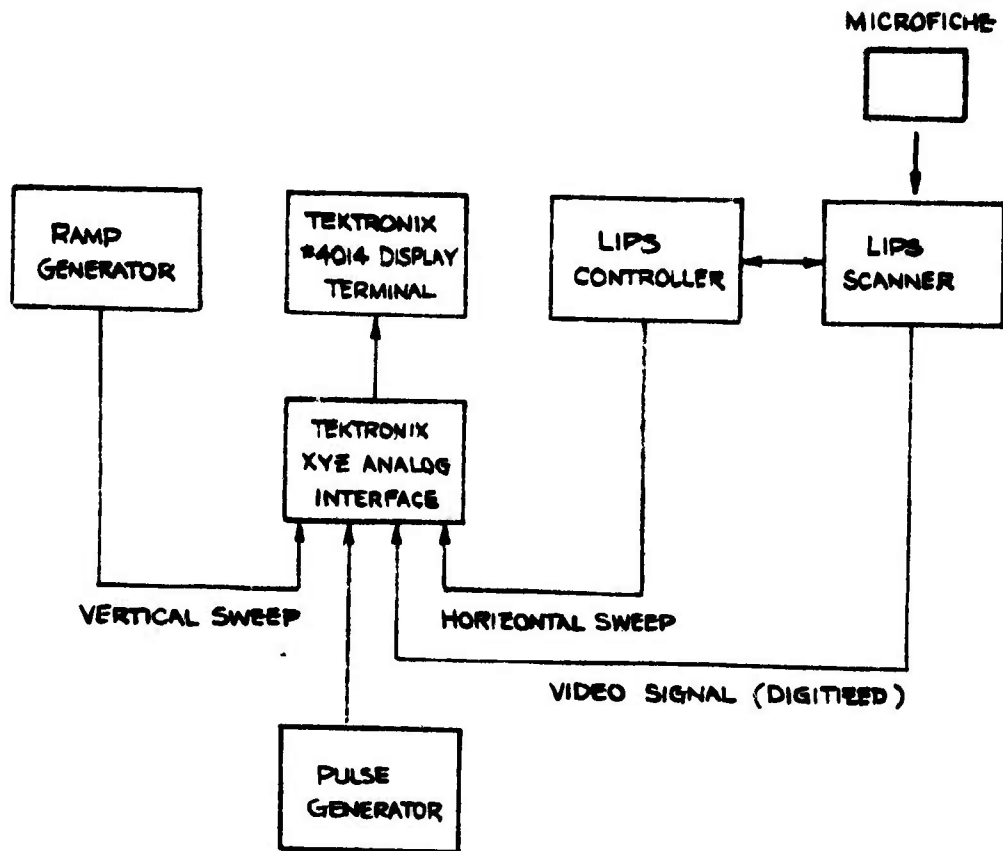

SIMULATION EXPERIMENTS TEST EQUIPMENT
 DISPLAY TERMINAL AND LIPS SCANNER

FIGURE B-1

This section will describe the simulation experiments performed with the #4014 Display Terminal, the experimental equipment, results obtained, and areas identified requiring further study. A number of tests were conducted including: display resolution, zoom experiments, writing speed tests, and pulsed writing.

B.1.1 TEST EQUIPMENT

A block diagram of the test equipment for the simulation tests is shown in Figure B-1. An actual photograph of the equipment is given in Figure B-2. The Laser Image Processing Scanner and controller (EPSCO Labs' product) provided the digitized video input signal obtained by scanning a microfiche image as well as the horizontal analog ramp to drive the display terminal. The vertical ramp signal and pulse width control signal (used for controlled pulse writing experiments) was supplied by commercial equipment. The digitized video signal, horizontal and vertical sweeps, and video pulse width signals were all fed into the Tektronix #4014 Display Terminal via a Tektronix XYZ Analog Input circuit board which allows the terminal to operate in an analog raster mode.

B.1.1.1 Laser Image Processing Scanner - The Laser Image Processing Scanner was used during the experiments in order to demonstrate display terminal limited performance. This was possible because of the small laser beam spot size available (1.25 to 40 microns) for scanning the microfiche.

A functional block diagram and photograph of the LIPS system with cover removed are shown in Figures B-3 and B-4. A central feature of the LIPS is the single laser which provides the light source for both scanning and recording.

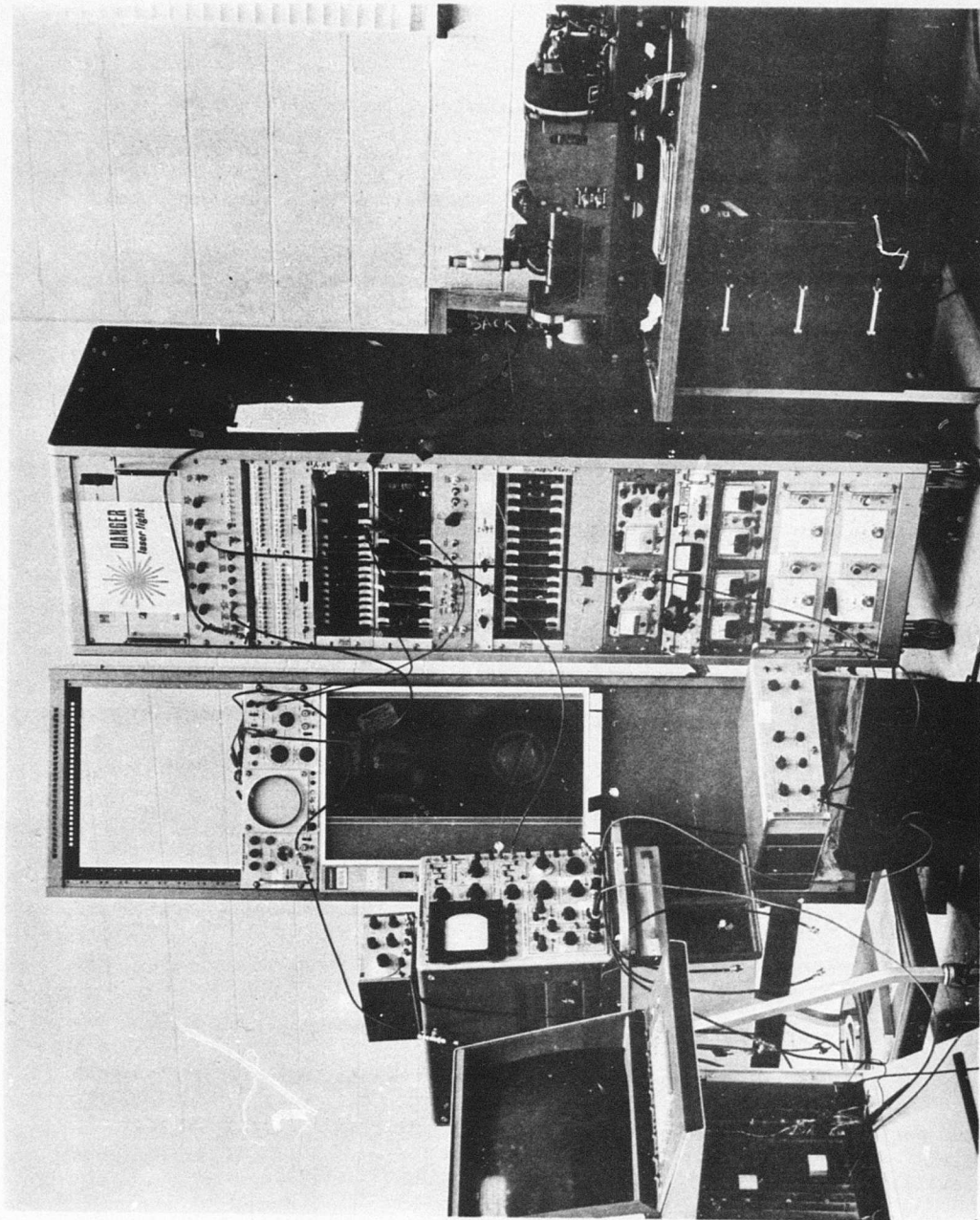

PHOTOGRAPH OF SIMULATION
EXPERIMENT TEST EQUIPMENT

FIGURE B-2

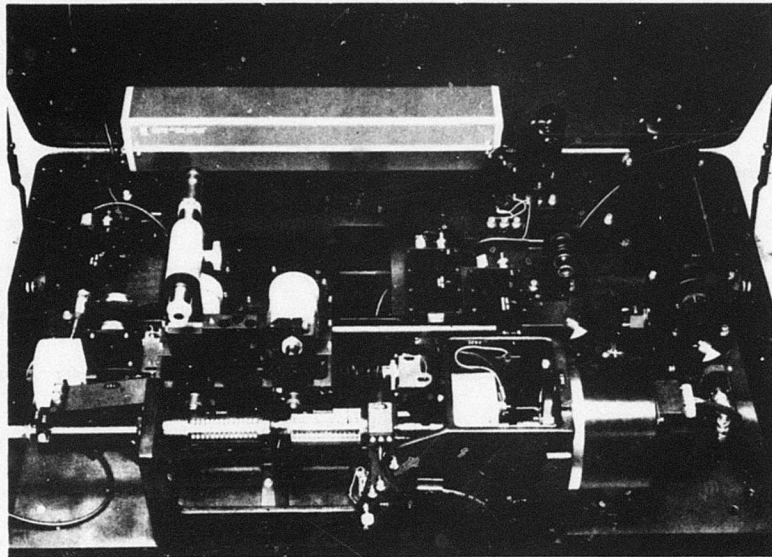

LASER IMAGE PROCESSING SCANNER (LIPS)

FIGURE B-3

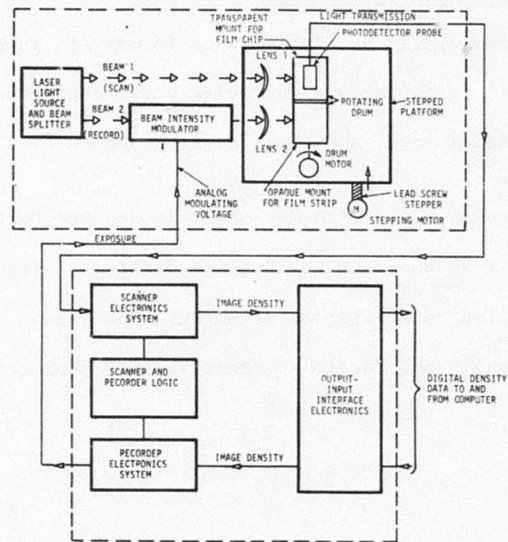

LASER IMAGE PROCESSING SCANNER (LIPS)
PHOTOGRAPH AND BLOCK DIAGRAM

FIGURE B-4

For the simulation experiments only the scanning function was required. In the scan mode the microfiche page to be scanned is mounted upon a precision quartz cylinder which has a photodetector inside. The cylinder is rotated and driven in an axial direction by means of a precision lead screw drive. With the scanning beam remaining stationary in space, the image may be scanned out line-by-line.

The signal is derived by scanning the film with the laser. The varying transmission of the microfiche provides analog voltage density values for each picture element. These density values are then digitized (either black or white for the display tests) and routed to the display terminal.

B.1.1.2 Tektronix #4014 Display Terminal - The Tektronix #4014 Display Terminal is a commercially available large format (15 inches wide by 11 inches high) display unit featuring a direct view storage cathode ray tube and a 96 character (full ASCII upper and lower case) keyboard.

The display unit (with keyboard) is secured to the pedestal to form a desk-height unit as shown in the outline drawing of Figure 4-25. The display unit can be modified to a vertical orientation as illustrated. The pedestal contains power supply and control circuitry, character generator, plus interface cards.

The terminal can operate in either a digital mode for character generation and vector plotting, or in a raster analog mode (with an optional interface circuit card) as in conventional television.

An important feature of the display terminal is its storage capability. Information needs to be transmitted to the CRT only once where it can be stored indefinitely. This results in a conservation of bandwidth since the display need not be refreshed as with a non-storage CRT. The resulting display is completely stable, without image motion effects or flicker.

B.1.2 RESOLUTION EXPERIMENTS

Resolution experiments were conducted to determine the optimum performance capability of the #4014 Display Terminal when displaying samples of the FTD microfiche data base.

Several parameters were varied during the tests including: the microfiche imagery, which contained characters of varying size, graphics, and variable density letters; the number of elements per line, laser beam spot size and threshold settings for controlling the display writing beam.

B.1.2.1 Microfiche Containing Typewritten Documents - Figure B-5 represents a photograph of an optically enlarged microfiche page containing typewritten letters with approximately 0.080" high lower case characters. The same page photographed as displayed on a good quality optical viewer is shown

REFERENCES

1. FTD CIRCOL Search No. 065385.
2. Defense Documentation Center, Search Control 009590.
3. Basil'yev, V. G., Glushkov, R. N., et al. "'TsAGI' System Flutter Indicator," Patent No. 200843, TRD-HT-23-1375-68, 1965.
4. Basis, A. Ts., Lazarev, L. I, Lebedev, A. G., and Strelkov, K. S. "Flutter Indicator," 1967.
5. "Model of an Aircraft in the Wind Tunnel Prior to Testing for Flutter," PRIRODA No. 5, 1970.
6. "Soviet Tu-144 SST Wing, Fuselage Section Tested," Aviation Week, April 19, 1971.
7. Bykov, V. S. and Komshinshiy, B. A. "A Device for Measuring Low Damping Moments when Testing Models in Wind Tunnels," USSR Patent No. 128179, FTD-HT-23-1854-72.
8. Matneyev, A. P. "A Device for Determining the Rotating Derivatives of Models with Respect to the Transverse Axis," USSR Patent No. 160884, FTD-HT-23-1620-74, February 26, 1964.
9. Belotserkouskiy, S. M., Bedenho, A. A. and Odnoval, L.A. "A Device for Determining the Rotational Derivatives of Models Studied in Aerodynamic Installations," USSR Patent No. 190634, FTD-HT-23-1619-74, December 29, 1966.
10. Bychkov, N. M., Dubrovskiy, B. L., and Kovalenko, V. M. "Experimental Investigation of the Magnus Effect on a Greatly Elongated Finned Rotating Body at $M = 4$," FTD-HT-23-32-74, 1972.

PHOTOGRAPH OF AN OPTICALLY ENLARGED
MICROFICHE PAGE OF A TYPEWRITTEN
DOCUMENT

FIGURE B-5

in Figure B-6. Several images were displayed on the #4014 terminal while varying the number of elements per scan line and the laser beam spot size. Figure B-7 represents the page digitized to 1600 elements per scan line (using a 2.5 micron laser spot diameter), while Figure B-8 illustrates a displayed image of 800 elements per line with the same spot size. Note that in the 1600 element case excellent results were obtained. No attempt was made to optimize resolution by pulsed writing techniques (see Section B.1.5). In subsequent experiments, a resolution of 1160 elements per line was determined to be a good trade-off in order to optimize legibility yet maintain a reasonable overall system configuration.

B.1.2.2 Microfiche Page Containing a Standard Government Form - Another test of the resolution capability of the Tektronix #4014 Display Terminal utilized the standard government form shown photographed in Figure B-9. The small italicized lower case letters are approximately 0.040" in height. Figure B-10 shows the same document photographed from an optical viewer (as an analyst presently perceives microfiche images at FTD). Displayed images are shown in Figures B-11 and B-12 where 1,600 and 800 elements per line are used respectively. The former display resulted in good legibility where the smallest words can be recognized. The use of 800 elements per line resulted in broken up illegible text.

REFERENCES

1. FTD CIRCOL Search No. 065385.
2. Defense Documentation Center, Search Control 009590.
3. Basil'yev, V. G., Glushkov, R. N., et al. "TsAGI System Flutter Indicator," Patent No. 200843, TRD-HT-23-1375-68, 1965.
4. Basis, A. Ts., Lazarev, L. I., Lebedev, A. G., and Strelkov, K. S. "Flutter Indicator," 1967.
5. "Model of an Aircraft in the Wind Tunnel Prior to Testing for Flutter," PRIRODA No. 5, 1970.
6. "Soviet Tu-144 SST Wing, Fuselage Section Tested," Aviation Week, April 19, 1971.
7. Bykov, V. S. and Komshinshiy, B. A. "A Device for Measuring Low Damping Moments when Testing Models in Wind Tunnels," USSR Patent No. 128179, FTD-HT-23-1854-72.
8. Matneyev, A. P. "A Device for Determining the Rotating Derivatives of Models with Respect to the Transverse Axis," USSR Patent No. 160854, FTD-HT-23-1620-74, February 26, 1964.
9. Belotserkouskiy, S. M., Bedenho, A. A. and Odnoval, L. A. "A Device for Determining the Rotational Derivatives of Models Studied in Aerodynamic Installations," USSR Patent No. 190634, FTD-HT-23-1619-74, December 29, 1966.
10. Bychkov, N. M., Dubrovskiy, B. L., and Kovalenko, V. M. "Experimental Investigation of the Magnus Effect on a Greatly Elongated Finned Rotating Body at $M = 4$," FTD-HT-23-32-74, 1972.

7

MICROFICHE PAGE PHOTOGRAPH
OF A TYPEWRITTEN DOCUMENT
DISPLAYED ON AN OPTICAL VIEWER

FIGURE B-6

#5
horizontal
mode 3
digitized
(1600 elements)

REFERENCES

1. FTD CIRCOL Search No. 065385.
2. Defense Documentation Center, Search Control 009590.
3. Basil'yev, V. G., Glushkov, R. N., et al. "'TsAGI' System Flutter Indicator," Patent No. 200843, TRD-HT-23-1375-68, 1965.
4. Basis, A. Ts., Lazarev, L. I., Lebedev, A. G., and Strelkov, K. S. "Flutter Indicator," 1967.
5. "Model of an Aircraft in the Wind Tunnel Prior to Testing for Flutter," PRIRODA No. 5, 1970.
6. "Soviet Tu-144 SST Wing, Fuselage Section Tested," Aviation Week, April 19, 1971.
7. Bykov, V. S. and Komshinshiy, B. A. "A Device for Measuring Low Damping Moments when Testing Models in Wind Tunnels," USSR Patent No. 128179, FTD-HT-23-1854-72.
8. Matneyev, A. P. "A Device for Determining the Rotating Derivatives of Models with Respect to the Transverse Axis," USSR Patent No. 160884, FTD-HT-23-1620-74, February 26, 1964.
9. Belotserkouskiy, S. M., Bedenho, A. A. and Odnoval, L.A. "A Device for Determining the Rotational Derivatives of Models Studied in Aerodynamic Installations," USSR Patent No. 190634, FTD-HT-23-1619-74, December 29, 1966.
10. Bychkov, N. M., Dubrovskiy, B. L., and Kovalenko, V. M. "Experimental Investigation of the Magnus Effect on a Greatly Elongated Finned Rotating Body at $M = 4$," FTD-HT-23-32-74, 1972.

MICROFICHE PAGE OF A TYPEWRITTEN
DOCUMENT DISPLAYED ON THE #4014
TERMINAL (1600 ELEMENTS/LINE)

FIGURE B-7

#5
horizontal
digitized
mode 4
(800 elements)

REFERENCES

1. FTD CIRCOL Search No. 065385.
2. Defense Documentation Center, Search Control 009590.
3. Basil'yev, V. G., Glushkov, R. N., et al. "TsAGI' System Flutter Indicator," Patent No. 200843, TRD-HT-23-1375-68, 1965.
4. Basis, A. Ts., Lazarev, L. I., Lebedev, A. G., and Strelkov, K. S. "Flutter Indicator," 1967.
5. "Model of an Aircraft in the Wind Tunnel Prior to Testing for Flutter," PRIRODA No. 5, 1970.
6. "Soviet Tu-144 SST Wing, Fuselage Section Tested," Aviation Week, April 19, 1971.
7. Bykov, V. S. and Komshinskiy, B. A. "A Device for Measuring Low Damping Moments when Testing Models in Wind Tunnels," USSR Patent No. 128179, FTD-HT-23-1854-72.
8. Matneyev, A. P. "A Device for Determining the Rotating Derivatives of Models with Respect to the Transverse Axis," USSR Patent No. 160884, FTD-HT-23-1620-74, February 26, 1964.
9. Belotserkouskiy, S. M., Bedenho, A. A. and Odnoval, L.A. "A Device for Determining the Rotational Derivatives of Models Studied in Aerodynamic Installations," USSR Patent No. 190634, FTD-HT-23-1619-74, December 29, 1966.
10. Bychkov, N. M., Dubrovskiy, B. L., and Kovalenko, V. M. "Experimental Investigation of the Magnus Effect on a Greatly Elongated Finned Rotating Body at $M = 4$," FTD-HT-23-32-74, 1972.

MICROFICHE PAGE OF A TYPEWRITTEN
DOCUMENT DISPLAYED ON THE #4014
TERMINAL (800 ELEMENTS/LINE)

FIGURE B-8

REPORT DOCUMENTATION PAGE		READ INSTRUCTIONS BEFORE COMPLETING FORM
1. REPORT NUMBER AEDC-CW-01-7-74	2. GOVT ACCESSION NO.	3. RECIPIENT'S CATALOG NUMBER
4. TITLE (and Subtitle) USSR Dynamic Testing Capability	5. TYPE OF REPORT & PERIOD COVERED	
	6. PERFORMING ORG. REPORT NUMBER	
7. AUTHOR(s) W. E. Carleton	8. CONTRACT OR GRANT NUMBER(s) F40600-74-C-0001	
9. PERFORMING ORGANIZATION NAME AND ADDRESS ARO, Inc. Arnold Engineering Development Center Arnold Air Force Station, Tennessee		10. PROGRAM ELEMENT PROJECT, TASK AREA & WORK UNIT NUMBERS
11. CONTROLLING OFFICE NAME AND ADDRESS Foreign Technology Division Wright-Patterson AFB, Ohio 45433	12. REPORT DATE June 1974	
	13. NUMBER OF PAGES 17	
14. MONITORING AGENCY NAME & ADDRESS (if different from Controlling Office)	15. SECURITY CLASS. (of this report) Unclassified	
	16. DECLASSIFICATION/DOWNGRADING SCHEDULE	
17. DISTRIBUTION STATEMENT (of this Report) This document is subject to special export controls and each transmittal to foreign governments or foreign nationals may be made only with prior approval of AEDC (DYF).		
18. DISTRIBUTION STATEMENT (of the abstract entered in Block 20, if different from Report)		
19. SUPPLEMENTARY NOTES		
20. KEY WORDS (Continue on reverse side if necessary and identify by block number)		
21. ABSTRACT (Continue on reverse side if necessary and identify by block number) This report presents the results of a search and study of available USSR literature and patent applications pertaining to test hardware used for dynamic stability, aeroelastic flutter, and gust load testing.		

14

DD FORM 1473 1 JAN 73 EDITION OF 1 NOV 68 IS OBSOLETE

SECURITY CLASSIFICATION OF THIS PAGE (When Data Entered)

PHOTOGRAPH OF AN OPTICALLY ENLARGED
MICROFICHE PAGE OF A STANDARD
GOVERNMENT FORM

FIGURE B-9

229

REPORT DOCUMENTATION PAGE		READ INSTRUCTIONS BEFORE COMPLETING FORM
1. REPORT NUMBER AEDC-CW-01-7-74	2. GOVT ACCESSION NO.	3. RECIPIENT'S CATALOG NUMBER
4. TITLE (and Subtitle) USSR Dynamic Testing Capability		5. TYPE OF REPORT & PERIOD COVERED
		6. PERFORMING ORG. REPORT NUMBER
7. AUTHOR(s) W. E. Carleton		8. CONTRACT OR GRANT NUMBER(s) F40600-74-C-0001
9. PERFORMING ORGANIZATION NAME AND ADDRESS ARO, Inc. Arnold Engineering Development Center Arnold Air Force Station, Tennessee		10. PROGRAM ELEMENT PROJECT, TASK AREA & WORK UNIT NUMBERS
11. CONTROLLING OFFICE NAME AND ADDRESS Foreign Technology Division Wright-Patterson AFB, Ohio 45433		12. REPORT DATE June 1974
14. MONITORING AGENCY NAME & ADDRESS (if different from Controlling Office)		13. NUMBER OF PAGES 17
		15. SECURITY CLASS. (of this report) Unclassified
		15a. DECLASSIFICATION/DOWNGRADING SCHEDULE
16. DISTRIBUTION STATEMENT (of this Report) This document is subject to special export controls and each transmittal to foreign governments or foreign nationals may be made only with prior approval of AEDC (DTF).		
17. DISTRIBUTION STATEMENT (of the abstract entered in Block 20, if different from Report)		
18. SUPPLEMENTARY NOTES		
19. KEY WORDS (Continue on reverse side if necessary and identify by block number)		
20. ABSTRACT (Continue on reverse side if necessary and identify by block number) This report presents the results of a search and study of available USSR literature and patent applications pertaining to test hardware used for dynamic stability, aeroelastic flutter, and gust load testing.		

14

DD FORM 1473 EDITION OF 1 NOV 65 IS OBSOLETE

SECURITY CLASSIFICATION OF THIS PAGE (When Data Entered)

MICROFICHE PAGE PHOTOGRAPH
OF A STANDARD GOVERNMENT FORM
DISPLAYED ON AN OPTICAL VIEWER

FIGURE B-10

230

#3 horizontal digitized mode 3 (1600elements)

1 REPORT NUMBER AEDC-CW-01-7-74	2 GOVT ACCESSION NO.	3 RECIPIENT'S CATALOG NUMBER
4 TITLE and Subtitle USSR Dynamic Testing Capability	5 TYPE OF REPORT & PERIOD COVERED	
6 AUTHOR W. E. Carleton	8 PERFORMING ORG. REPORT NUMBER	
7 PERFORMING ORGANIZATION NAME AND ADDRESS ARO, Inc. Arnold Engineering Development Center Arnold Air Force Station, Tennessee	9 CONTRACT OR GRANT NUMBER(s) F40600-74-C-0001	
11 CONTROLLING OFFICE NAME AND ADDRESS Foreign Technology Division Wright-Patterson AFB, Ohio 45433	10 PROGRAM ELEMENT PROJECT TASK AREA & WORK UNIT NUMBERS	
14 MONITORING AGENCY NAME & ADDRESS (if different from Controlling Office)	12 REPORT DATE June 1974	13 NUMBER OF PAGES 17
	15 SECURITY CLASS. (of this report) Unclassified	15a DECLASSIFICATION/DOWNGRADING SCHEDULE
16 DISTRIBUTION STATEMENT (of this Report) This document is subject to special export controls and each transmittal to foreign governments or foreign nationals may be made only with prior approval of AEDC (DYP).		
17 DISTRIBUTION STATEMENT (of the abstract entered in Block 20, if different from Report)		
18 SUPPLEMENTARY NOTES		
19 KEY WORDS (Continue on reverse side if necessary and identify by block number)		
20 ABSTRACT (Continue on reverse side if necessary and identify by block number) This report presents the results of a search and study of available USSR literature and patent applications pertaining to test hardware used for dynamic stability, aeroelastic flutter, and gust load testing.		

DD FORM 1 JAN 73 1473 EDITION OF 1 NOV 68 IS OBSOLETE

SECURITY CLASSIFICATION OF THIS PAGE (When Data Entered)

MICROFICHE PAGE OF A STANDARD
GOVERNMENT DOCUMENT DISPLAYED
ON THE #4014 TERMINAL
(1600 ELEMENTS/LINE)

FIGURE B-11

SECURITY CLASSIFICATION OF THIS PAGE (When Data Entered)

REPORT DOCUMENTATION PAGE		READ INSTRUCTIONS BEFORE COMPLETING FORM	
1. REPORT NUMBER AEDC-CH-01-7-74	7. GOVT ACCESSION NO.	3. RECIPIENT'S CATALOG NUMBER	
4. TITLE and Subtitle USSR Dynamic Testing Capability	5. TYPE OF REPORT & PERIOD COVERED		
6. AUTHOR W. E. Carleton	8. PERFORMING ORG. REPORT NUMBER		
9. PERFORMING ORGANIZATION NAME AND ADDRESS ARO, Inc. Arnold Engineering Development Center Arnold Air Force Station, Tennessee	10. CONTRACT OR GRANT NUMBER F40600-74-C-0001		
11. CONTROLLING OFFICE NAME AND ADDRESS Foreign Technology Division Wright-Patterson AFB, Ohio 45433	12. REPORT DATE June 1974		
14. MONITORING AGENCY NAME & ADDRESS (if different from Controlling Office)	13. NUMBER OF PAGES 17		
	15. SECURITY CLASS. of this report Unclassified		
	15a. DECLASSIFICATION/DOWNGRADING SCHEDULE		
16. DISTRIBUTION STATEMENT (of this Report) This document is subject to special export controls and each transmittal to foreign governments or foreign nationals may be made only with prior approval of AEDC (DYP).			
17. DISTRIBUTION STATEMENT (of the abstract entered in block 20, if different from Report)			
18. SUPPLEMENTARY NOTES			
19. KEY WORDS (Continue on reverse side if necessary and identify by block number)			
20. ABSTRACT (Continue on reverse side if necessary and identify by block number) This report presents the results of a search and study of available USSR literature and patent applications pertaining to test hardware used for dynamic stability, aeroelastic flutter, and gust load testing.			

MICROFICHE PAGE OF A STANDARD
GOVERNMENT DOCUMENT DISPLAYED
ON THE #4014 TERMINAL
(800 ELEMENTS/LINE)

FIGURE B-12

B.1.3 ZOOM EXPERIMENTS

The need for a "zoom" capability, or ability to magnify an image by a factor of two, becomes apparent when microfiche pages typical of Figure B-13 are displayed. Figure B-14 shows the same microfiche photographed from the display terminal. Note that many of the graphs and subscripts are so small they are impossible to read.

A zoom capability was simulated by scanning the microfiche image at twice the resolution (3200 elements per line) and only displaying one-quarter of the page (1600 elements per half-line). Figures B-15 and B-16 show the result of 2X zoom. While the legibility of the text and graph has improved, subscripts are still difficult to read. It is clear that some type of image enhancement is needed to bring out the subscripts and grid lines on the graph.

B.1.4 MICROFICHE DENSITY VARIATIONS

Although the results obtained during the zoom experiments were good for most of the microfiche sampled, the adverse effect of variations of the film density across extremely small characters and fine grid lines was evident. It is apparent that the legibility of these characters is affected by the threshold level used in digitizing the analog signal obtained from the microfiche scanner. Full use of the microfiche is not being utilized,

Bild 1a
Einfluß der Sinteratmosphäre auf die Dichte von Nickel-Zink-Ferrit

Bild 1b
Einfluß der Sinteratmosphäre auf die Anfangspermeabilität von Nickel-Zink-Ferrit

Schritte kann bis heute nur auf experimentellem Wege erfolgen, wobei theoretische Überlegungen allerdings wertvolle Hilfe bei der Auswahl der durchzuführenden Versuche leisten können.

Nickel-Zink-Ferrite

Nickel-Zink-Ferrite geringer Porosität werden als Material für Aufzeichnungsköpfe für Magnetbandgeräten benutzt und auch für Mikrowellen-Ferritbauelemente haben sie einige Bedeutung. Ein weiteres Anwendungsgebiet könnten induktive Bauelemente für Ultrakurzwellen sein. Bei Magnetköpfen ist geringe Porosität erforderlich um einwandfreie Spaltgeometrie verwirklichen zu können und um möglichst hohe Verschleißfestigkeit zu erhalten. Hier stehen also die mechanischen Eigenschaften im Vordergrund, während in den anderen Fällen die geringe Porosität zur Erzielung bestimmter magnetischer Eigenschaften erforderlich ist.

Nickel-Zink-Ferrite kann man verhältnismäßig leicht mit hoher relativer Dichte herstellen. Schwierigkeiten bereiten erst Porositäten unter 1%.

Betrachtet man zunächst den Sinterprozeß, so gilt in der Keramik die Regel, daß man mit steigender Sinter Temperatur und Sinterdauer geringere Porositäten erhält. Die Oberflächenenergie an den Grenzflächen zwischen den Poren und dem kompakten Material wird durch die Verkleinerung der Poren verringert, wobei der hierzu erforderliche Materialtransport durch Diffusion erfolgt. Bei Ferriten kann dieser Vorgang jedoch dadurch gestört werden, daß der Werkstoff bei hoher Temperatur nicht stabil ist. Bei Nickel-Zink-Ferriten der Formel



können bei hohen Temperaturen zwei störende Prozesse auftreten. Zum ersten gilt, formal gesehen, auch für das im Ferrit enthaltene Eisenoxid die Reaktionsgleichung

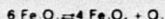

wobei sich das Gleichgewicht mit steigender Temperatur nach rechts verschiebt. Die Sauerstoffabspaltung wirkt in Richtung auf eine Neubildung oder die Vergrößerung vorhandener Poren. Gleichzeitig führt die Abspaltung von Sauerstoff zur Bildung von Anionenfehlstellen und damit zu Veränderungen der magnetischen Eigenschaften. Um nun die Sauerstoffabspaltung einzuschränken oder zu verhindern, empfiehlt sich die Sinterung in einer Atmosphäre von hohem Sauerstoffpartialdruck.

Der zweite Prozeß, der die Anwendbarkeit hoher Sintertemperaturen und langer Sinterzeiten erschwert, ist die Verflüchtigung

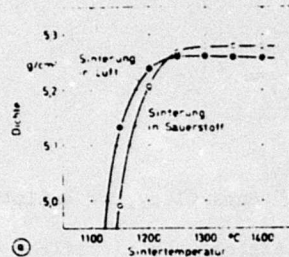

(a)

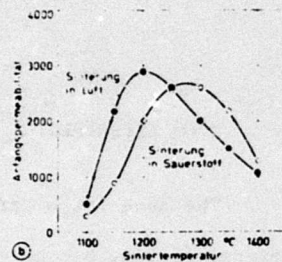

(b)

von Zink. Dieser Vorgang spielt sich an der Oberfläche des Ferrits ab und führt zu einer analytisch nachweisbaren mit zunehmendem Abstand von der Oberfläche abnehmenden Verarmung des Ferrits an Zink. Inwieweit die Zinkverdampfung einen Einfluß auf die Porosität hat, ist unklar. In Einfluß auf die magnetischen Eigenschaften zwingt jedoch dazu die Abspaltung von Zink zu unterdrücken. Bekannt ist, daß auch die Zinkabspaltung durch Erhöhen des Sauerstoffpartialdrucks in der Sinteratmosphäre verringert werden kann. Ein Beispiel dafür, daß die Sinterung in Sauerstoff von Atmosphärendruck tatsächlich zu höheren Dichtewerten führt als die Sinterung in Luft, zeigt Bild 1a für den Fall eines Nickel-Zink-Ferrits der Zusammensetzung

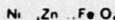

Überhalb 1250°C Sinter Temperatur sind die Dichtewerte bei Sinterung in Sauerstoff größer, bei tieferen Sinter Temperaturen ergibt sich allerdings in Luft eine relativ höhere Dichte. Bild 1b zeigt für denselben Fall den Verlauf der Anfangspermeabilität. Auch hier hat das in Luft gesinterte Ferrit bei niedrigen Sinter Temperaturen eine höhere Permeabilität, die oberhalb 1200°C aber stark abfällt. Bei Sinterung in Sauerstoff bleibt der Maximalwert niedriger und wird erst bei höheren Sinter Temperaturen erreicht. Auch die Kristallitgröße liegt bei Sinterung in Luft zunächst höher, steigt aber mit zunehmender Sinter Temperatur schwächer an. Ein ähnliches Verhalten wurde auch an anderen stochiometrisch zusammengesetzten Nickel-Zink-Ferriten beobachtet, und man möchte daraus schließen, daß bei Sinterung in Luft das Material eine höhere

Fehlstellenkonzentration hat, die den Ablauf des Sinterprozesses zunächst begünstigt, bei hohen Sinter Temperaturen der negative Einfluß der Sauerstoffabspaltung und Zinkverdampfung überwiegt. Diese Ergebnisse legen es nahe, bei der Sinterung zunächst in sauerstoffarmer Atmosphäre aufzuheizen und erst mit steigender Temperatur den Sauerstoffpartialdruck zu erhöhen. Um noch höhere Dichtewerte zu erhalten, scheinen Sinterungen unter noch höherem weit über Atmosphärendruck hinausreichendem Sauerstoffpartialdruck sinnvoll, doch wurden derartige Versuche nicht durchgeführt.

Um die bei hohen Sinter Temperaturen störenden Einflüsse auszuschalten, wird man nun bestrebt sein, die zur Erzielung hochdichter Ferrite notwendigen Temperaturen abzusenken. Dazu muß man von der Beschaffenheit der zu sinternden Teile ausgehen. Diese Teile werden mit Hilfe eines Preßvorgangs aus einem pulverförmigen Rohstoffgemisch oder einem Ferritpulver, bis aber noch kein vollständig ausgebildetes Spinnlitter zu haben braucht, hergestellt. Wesentlich für die erforderliche Sinter Temperatur sind die Eigenschaften des Pulvers und die angewandten Preßbedingungen. Beim Preßvorgang wird man sich bemühen, einen wenig porösen Preßling zu erhalten, in dem die Berührungsfächen zwischen den einzelnen Partikeln zur Erleichterung des Sinterprozesses möglichst groß sind. Die relative Dichte eines solchen Preßlings liegt im allgemeinen zwischen 55 und 70% von derjenigen des fertigen Ferrits. Da die Rohstoffe oder Ferritpulver nicht plastisch verformbar sind, erreicht die Preßdichte mit steigendem Preßdruck sehr bald einen Grenzwert.



Bild 2
Dichte von gepreßten (a) und von gesinterten (b) Ferriteilen

PHOTOGRAPH OF MICROFICHE PAGE
WITH SMALL SUBSCRIPTS AND GRAPHS

FIGURE B-13

Bild 1a
Einfluß der Sinteratmosphäre auf die Dichte von Nickel-Zink-Ferrit

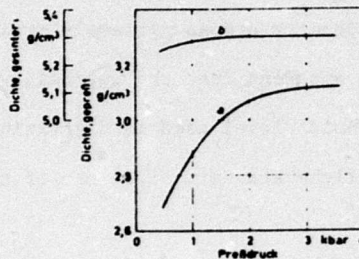
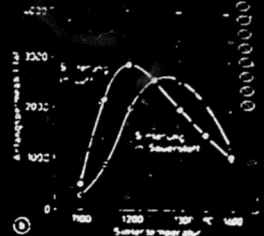
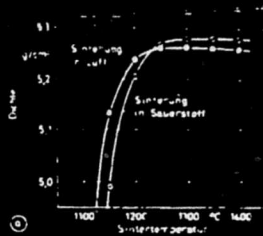

schritte kann bis heute nur auf experimentellem Wege erdäugt wobei theoretische Überlegungen allerdings wertvolle Hilfe bei der Auswahl der durchzuführenden Versuche leisten können

Nickel-Zink-Ferrite

Nickel-Zink-Ferrite geringer Porosita, werden als Material für Aufzeichnungsköpfe in Magnetbändergeräten benutzt und auch für Mikrowellen-Ferritbauelemente, haben sie einige Bedeutung. Ein weiteres Anwendungsgebiet könnten induktive Bauelemente für Ultrakurzwellen sein. Bei Magnetköpfen ist geringe Porosität erforderlich um einwandfreie Spaltgeometrien verwirklichen zu können und um möglichst hohe Verschleißfestigkeit zu erhalten. Hier stehen also die mechanischen Eigenschaften im Vordergrund, während in den anderen Fällen die geringe Porosität zur Erzielung bestimmter magnetischer Eigenschaften erforderlich ist.

Nickel-Zink-Ferrite kann man verhältnismäßig leicht mit hoher relativer Dichte herstellen. Schwierigkeiten bereiten erst Porositäten unter 1%.

Betrachtet man zunächst den Sinterprozeß so gilt in der Keramik die Regel, daß man mit steigender Sinter-temperatur und Sinterdauer geringere Porositäten erhält. Die Oberflächenenergie an den Grenzflächen zwischen den Poren und dem kompakten Material wird durch die Verkleinerung der Poren verringert, wobei der hierzu erforderliche Materialtransport durch Diffusion erfolgt. Bei Ferriten kann dieser Vorgang jedoch dadurch gestört werden, daß der Werkstoff bei hoher Temperatur nicht stabil ist. Bei Nickel-Zink-Ferriten der Formel



können bei hohen Temperaturen zwei störende Prozesse auftreten. Zum ersten gilt, formal gesehen, auch für das im Ferrit enthaltene Eisenoxid die Reaktionsgleichung

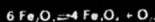

wobei sich das Gleichgewicht mit steigender Temperatur nach rechts verschiebt. Die Sauerstoffabspaltung wirkt in Richtung auf eine Neubildung oder die Vergrößerung vorhandener Poren. Gleichzeitig führt die Abspaltung von Sauerstoff zur Bildung von Anionenfehlstellen und damit zu Veränderungen der magnetischen Eigenschaften. Um nun die Sauerstoffabspaltung einzuschränken oder zu verhindern empfiehlt sich die Sinterung in einer Atmosphäre von hohem Sauerstoffpartialdruck.

Der zweite Prozeß, der die Anwendbarkeit hoher Sinter-temperaturen und langer Sinterzeiten erschwert, ist die Verflüchtigung

von Zink. Dieser Vorgang spielt sich an der Oberfläche des Ferrits ab und führt zu einer analytisch nachweisbaren mit zunehmendem Abstand von der Oberfläche abnehmenden Verarmung des Ferrits an Zink. Inwieweit die Zinkverdampfung einen Einfluß auf die Porosität hat, ist unklar. Ihr Einfluß auf die magnetischen Eigenschaften zwingt jedoch dazu, die Abspaltung von Zink zu unterdrücken. Bekannt ist, daß auch die Zinkabspaltung durch Erhöhung des Sauerstoffpartialdrucks in der Sinteratmosphäre verringert werden kann. Ein Beispiel dafür, daß die Sinterung in Sauerstoff von Atmosphärendruck tatsächlich zu höheren Dichtewerten führt als die Sinterung in Luft, zeigt Bild 1a für den Fall eines Nickel-Zink-Ferrits der Zusammensetzung

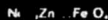

Obenhalb 1250°C Sinter-temperatur sind die Dichtewerte bei Sinterung in Sauerstoff größer, bei tieferen Sinter-temperaturen ergibt sich allerdings in Luft eine relativ höhere Dichte. Bild 1b zeigt für denselben Fall den Verlauf der Anfangspermeabilität. Auch hier hat das in Luft gesinterte Ferrit bei niedrigen Sinter-temperaturen eine höhere Permeabilität, die oberhalb 1200°C aber stark abfällt. Bei Sinterung in Sauerstoff bleibt der Maximalwert niedriger und wird erst bei höheren Sinter-temperaturen erreicht. Auch die Kristallitengröße liegt bei Sinterung in Luft zunächst höher, steigt aber mit zunehmender Sinter-temperatur schwächer an. Ein ähnliches Verhalten wurde auch an anderen stöchiometrisch zusammengesetzten Nickel-Zink-Ferriten beobachtet und man möchte daraus schließen, daß bei Sinterung in Luft das Material eine höhere

Fehlstellenkonzentration hat, die den Ablauf des Sinterprozesses zunächst begünstigt, bei hohen Sinter-temperaturen der negative Einfluß der Sauerstoffabspaltung und Zinkverdampfung überwiegt. Diese Ergebnisse legen es nahe, bei der Sinterung zu nächst in sauerstoffreicher Atmosphäre aufzunehmen und erst mit steigender Temperatur den Sauerstoffpartialdruck zu erhöhen. Um noch höhere Dichtewerte zu erhalten, scheitern Sinterungen unter noch höherwertigen Atmosphärendrücken hinaus, da der Sauerstoffpartialdruck, obwohl durch die geringeren Verdampfungsverluste, nicht

Um die bei hohen Sinter-temperaturen störenden Einflüsse auszuschalten, wird man nun bestrebt sein, die zur Erzielung hochdichter Ferrite notwendigen Temperaturen abzusenken. Dazu muß man von der Beschaffenheit der zu sinternden Teile ausgehen. Diese Teile werden mit Hilfe eines Prüfverfahrens aus einem pulverförmigen Rohstoffgemisch oder einem Ferritpulver, das aber noch kein vollständig ausgebildetes Spinngeflecht zu haben braucht, hergestellt. Wesentlich für die erforderliche Sinter-temperatur sind die Eigenschaften des Pulvers und die angewandten Prüfbedingungen. Beim Prüfverfahren wird man sich bemühen, einen wenig porösen Prüfling zu erhalten, in dem die Benetzungsfächen zwischen den einzelnen Partikeln zur Erleichterung des Sinterprozesses möglichst groß sind. Die relative Dichte eines solchen Prüflings liegt im allgemeinen zwischen 55 und 70% von derjenigen des fertigen Ferrits. Da die Rohstoffe oder Ferritpulver nicht glasig verformbar sind, erreicht die Prüflingsdichte mit steigendem Prüfdruck sehr bald einen Grenzwert.

Bild 2
Dichte von gepreßten (a) und von gesinterten (b) Ferritteilen

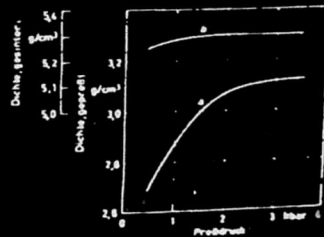

MICROFICHE PAGE WITH SMALL SYMBOLS & GRAPHS DISPLAYED ON THE #4014 TERMINAL

FIGURE B-14

verwirklichen zu können und um möglichst hohe Verschleißfestigkeit zu erhalten. Hier stehen also die mechanischen Eigenschaften im Vordergrund, während in den anderen Fällen die geringe Porosität zur Erzielung bestimmter magnetischer Eigenschaften erforderlich ist.

Nickel-Zink-Ferrite kann man verhältnismäßig leicht mit hoher relativer Dichte herstellen. Schwierigkeiten bereiten erst Porositäten unter 1%.

Betrachtet man zunächst den Sinterprozess, so gilt in der Keramik die Regel, daß man mit steigender Sintertemperatur und Sinterdauer geringere Porositäten erhält. Die Oberflächenenergie an den Grenzflächen zwischen den Poren und dem kompakten Material wird durch die Verkleinerung der Poren verringert, wobei der hierzu erforderliche Materialtransport durch Diffusion erfolgt. Bei Ferriten kann dieser Vorgang jedoch dadurch gestört werden, daß der Werkstoff bei hoher Temperatur nicht stabil ist. Bei Nickel-Zink-Ferriten der Formel



können bei hohen Temperaturen zwei störende Prozesse auftreten. Zum ersten gilt, formal gesehen, auch für das im Ferrit enthaltene Eisenoxid die Reaktionsgleichung



wobei sich das Gleichgewicht mit steigender Temperatur nach rechts verschiebt. Die Sauerstoffabspaltung wirkt in Richtung auf eine Neubildung oder die Vergrößerung

auch die Zinkabspaltung. Durch den Sauerstoffpartialdruck in der Atmosphäre verringert wird. Beispiel dafür, daß die Sinterung bei höherem Atmosphärendruck zu höheren Dichtewerten führt, zeigt Bild 1a für Nickel-Zink-Ferrite; der Zusatz

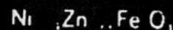

Obwohl bei 1250°C Sinterung die Dichtewerte bei Sinterung bei tieferen Temperaturen ergibt sich allerdings in der Regel höhere Dichte. Bild 1b zeigt im selben Fall den Verlauf der Permeabilität. Auch hier hat das Ferrit bei niedriger Sinterung eine höhere Permeabilität, die aber stark abfällt. Bei Sinterung bleibt der Maximalwert niedriger, erst bei höherer Sinterung. Auch die Kristallitengröße liegt bei Sinterung in Luft zunächst höher und mit zunehmender Sinterung sinkt sie ab. Ein ähnliches Verhalten auch an anderen stochiometrisch gesetzten Nickel-Zink-Ferriten, und man möchte daraus schließen, daß bei Sinterung in Luft das Material

11211-1 from 2X magnified 1600 elements (mode 3) opt for subscr

2X ZOOM MAGNIFICATION OF
MICROFICHE PAGE DISPLAYED

FIGURE B-15

1121-5 zoom Ex digitized 3200 elements (mode 2)
opt for subscr. as -3 etc.

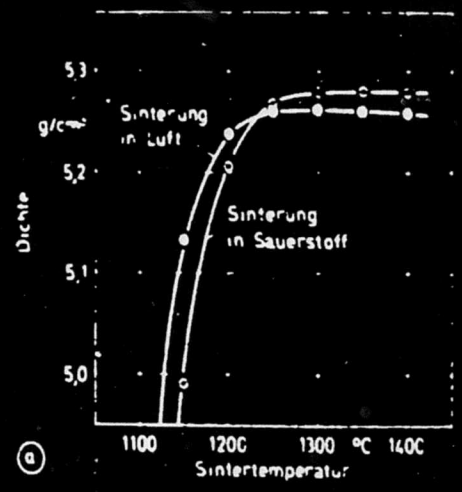

gung von Zink Dieser Vorgang spielt sich an der Oberfläche des Ferrits ab und führt zu einer analytisch nachweisbaren, mit zunehmendem Abstand von der Oberfläche abnehmenden Verarmung des Ferrits an Zink Inwieweit die Zinkverdampfung einen Einfluß auf die Porosität hat, ist unklar Ihr

2X ZOOM MAGNIFICATION OF MICROFICHE PAGE DISPLAYED

FIGURE B-16

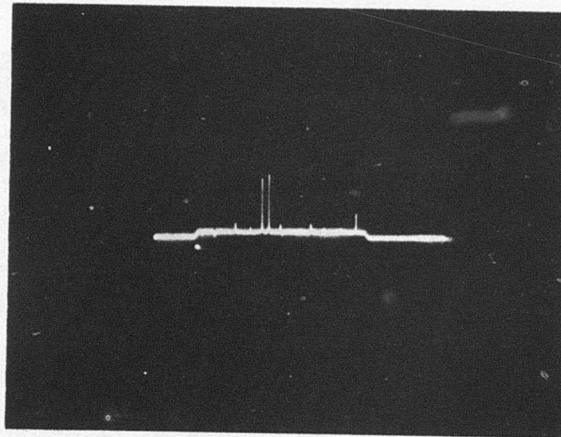

A-SCOPE TRACE PHOTOGRAPH

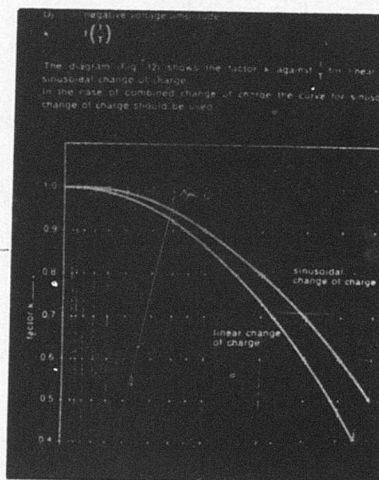

Scan Line
Represented
by A-scope Trace

DISPLAYED IMAGE PHOTOGRAPH

ANALOG SIGNAL AMPLITUDE VARIATIONS
CAUSED BY MICROFICHE DENSITY VARIATIONS

FIGURE B-17

particularly in the high resolution zoom mode of system operation.

An illustration of the amplitude variations that occur in the analog output from the microfiche scanner as a result of film density variations and scanner spot characteristics is shown in Figure B-17.

The A-scope photograph on top shows the amplitude variations of the analog signal at the scanner. The photograph on the bottom gives the displayed image with the location of the A-scope scan line identified. Note that on the A-scope trace the signal representing the vertical grid lines are very low in amplitude compared to the two plotted curves. It is apparent from this amplitude variation that some form of threshold circuitry is needed to enhance the low amplitude signals.

B.1.4.1 Threshold Optimization - It is recommended that the thresholding problem should be studied and circuitry developed which will optimize the legibility of microfiche pages containing excessive density variations. If this is accomplished, the high resolution zoom will provide excellent legibility.

As an example of what could be done, a simplified block diagram of one possible threshold circuit is shown in Figure B-18. The associated timing diagram for the circuit is illustrated in Figure B-19.

The purpose of the circuit is twofold. First, the average value of image intensity is determined by sampling the data with positive and negative peak detectors. The result is used to set a reference level for thresholding purposes. This is done on a continuous basis (with a circuit which has a relatively long response time) in order to compensate for any slow changes in average intensity which may take place during the course of scanning a microfiche. The second purpose is to detect and record data that exceeds the set threshold (which is set at a particular level to avoid short noise pulses and image blooming or smearing problems) and in addition to detect data occurring at a second (lower) threshold which would normally go unnoticed in the presence of high amplitude data.

This is accomplished by digitizing the analog video signal using a 2-bit (or greater depending on the accuracy required) A/D converter, placing the data in an N element shift register, and then continually comparing the output of the 1st stage with the last stage. If the binary weight of the digitized data goes above the first or highest predetermined level, then the data is recorded as it is shifted out of the register. If the data exceeds the second or lower threshold level, it is recorded only if succeeding elements do not exceed the first threshold (in which case all previous data is ignored) and also only when the level of a succeeding element falls below the second threshold. In this manner, data of normally inadequate amplitude can be preserved. Obviously, the amount of data which can be saved depends on the length of the memory or shift register used. In addition, the shift register, as shown in the timing diagram, delays the output by a number of elements equal to the number of stages in the register.



DISPLAY RESOLUTION DURING
PULSED WRITING EXPERIMENTS

FIGURE B-20

B.1.5 PULSED WRITING EXPERIMENTS

The #4014 Display Terminal storage target is a unique screen surface containing a discrete array of collector electrodes spaced 160 per linear inch in a rectangular matrix (refer to Section 3.2.2.2). Because of this discrete collector array, the spot size displayed on the screen will vary substantially depending on the electron beam charge density delivered. As the charge density is reduced, the spot size becomes smaller. However, as the charge density is further reduced a point is finally reached where the image is not stored. In recognition of the fact that the spot size could be optimized, a series of pulsed writing tests were made to control the time interval during which charge is delivered to the screen.

Figure B-20 shows the results obtained by varying the time interval from 200 microseconds to 800 nseconds with no overlap of the recorded spots. Observe that as the time interval becomes shorter, the spot diameter is reduced. At 800 nseconds, storage is not achieved over the entire format.

An example of a portion of a displayed microfiche page (magnified by scanning in the zoom mode) is shown in Figure B-21. Part of the display was generated without pulsing, part with 1.0 microsecond interval pulsing, and part with 0.6 microsecond pulsing. The pulsed portion is clearly more legible than the unpulsed text. Since the resolution elements overlap one another, storage was

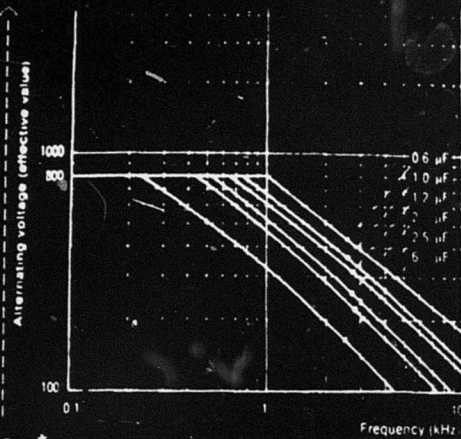

Fig 11 Permissible capacitor AC voltage shown against frequency for capacitor rated voltage $U_{N_{eff}} = 800$ V

2.5.5 Calculation of capacitor current

The following formula is valid for linear change in charge

$$J_{eff} = \frac{C(U_1 + U_2)}{T} \cdot \sqrt{\frac{T}{t_1} + \frac{T}{t_2}}$$

The following formula is valid for sinusoidal and combined change in charge according to Fig 3b or 3c

$$\frac{\pi}{2\sqrt{2}} \cdot \frac{C(U_1 + U_2)}{T} \cdot \sqrt{\frac{T}{t_1} + \frac{T}{t_2}}$$

C Capacity (F)
 J_{eff} Capacitive current (effective value) (Amps)
 T period time (sec)
 t_1 change of charge time (see Fig 3) (sec)
 U positive voltage amplitude (V)

sinusoidal change of charge
 In the case of combined change of charge the curves for sinusoidal change of charge should be used

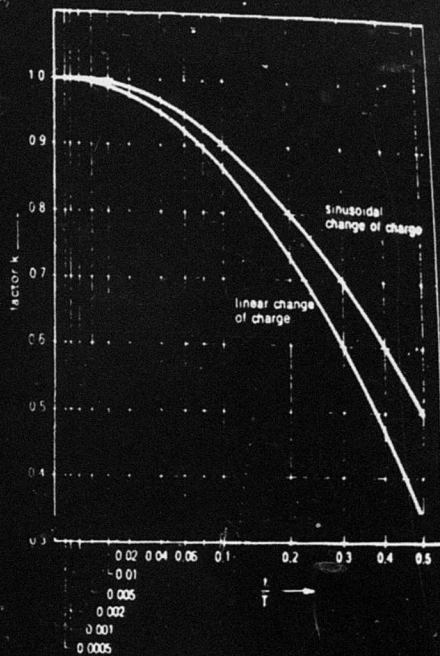

Fig 12 Factor k for power calculation

With trapezoidal voltage having a steep rise slope the power can reach a very high value. The power limiting values quoted in the specification sheet at a housing temperature of +85°C must not be exceeded.

2.5.7 Permissible temperatures

The rated values for voltage current and power (see specification sheet for MPK capacitors) relate to a housing temperature of +85°C. For lower housing temperatures higher values are permissible (factors > 1 see Figs. 13 to 15).

DISPLAY SHOWING RESULTS
 OF PULSED WRITING

FIGURE B-21

achieved even when using the 0.6 microsecond pulse width.

We conclude from these tests, that the resolution of images displayed on the #4014 Display Terminal can be optimized by using controlled pulse writing.

B.1.6 WRITING RATE

The writing rate of the display unit is specified as 5,000 inches per second by Tektronix. The writing rate was tested in order to see if the specification is conservative and if faster rates can be used.

Tests indicated that rates up to 15,000 inches per second could be used without loss in storage. It is recognized, however, that only one display terminal was tested, and that different display control settings may cause a large variation in results. One caution that must be observed is that the allowable writing rate may decrease as the display phosphor ages. Thus after several thousand hours, near the end of tube life, the writing rate limit may begin to approach the specified value.

During actual system operation the display would have to operate at less than 3,000 inches per second writing rate to keep up with the transmission channel speed. Data may be buffered into the display at a much faster rate than the transmission rate and still remain within the conservative writing rate specification.

verwirklichen zu können und um möglichst hohe Verschleißfestigkeit zu erhalten. Hier stehen also die mechanischen Eigenschaften im Vordergrund, während in den anderen Fällen die geringe Porosität zur Erzielung bestimmter magnetischer Eigenschaften erforderlich ist.

Nickel-Zink-Ferrite kann man verhältnismäßig leicht mit hoher relativer Dichte herstellen. Schwierigkeiten bereiten erst Porositäten unter 1%.

Betrachtet man zunächst den Sinterprozess, so gilt in der Keramik die Regel, daß man mit steigender Sinter-temperatur und Sinterdauer geringere Porositäten erhält. Die Oberflächenenergie an den Grenzflächen zwischen den Poren und dem kompakten Material wird durch die Verkleinerung der Poren verringert, wobei der hierzu erforderliche Materialtransport durch Diffusion erfolgt. Bei Ferriten kann dieser Vorgang jedoch dadurch gestört werden, daß der Werkstoff bei hoher Temperatur nicht stabil ist. Bei Nickel-Zink-Ferriten der Formel



können bei hohen Temperaturen zwei störende Prozesse auftreten. Zum ersten gilt, formal gesehen, auch für das im Ferrit enthaltene Eisenoxid die Reaktionsgleichung



wobei sich das Gleichgewicht mit steigender Temperatur nach rechts verschiebt. Die

auch die Zinkabsorption durch den Sauerstoffpartialdruck in der Atmosphäre verringert wird. Beispiel dafür, daß die Sinterung von Atmosphärendruck zu höheren Dichtewerten führt, zeigt Bild 1a für Nickel-Zink-Ferrit; der Zusatz



Oberhalb 1250°C Sinter-temperatur ergibt sich allerdings in diesem Fall der Verlauf der Permeabilität. Auch hier hat das Ferrit bei niedriger Sinter-temperatur eine höhere Permeabilität, die aber stark abfällt. Bei Sinterung bleibt der Maximalwert niedrig. Auch die Kristallitengröße bei Sinterung in Luft zunächst höher mit zunehmender Sinter-temperatur an. Ein ähnliches Verhalten auch an anderen stochiometrisch gesetzten Nickel-Zink-Ferriten, und man möchte daraus schließen, daß bei Sinterung in Luft das Material

1121-1 zoom 2X digitized 1600 elements mode 51 opt for subscr

PHOTOGRAPH OF HARD COPY SHOWING
DISPLAYED PAGE OF FIGURE B-15

FIGURE B-22

B.1.7 HARD COPY UNIT

A Tektronix Model #4631 Hard Copy Unit was tested during the simulation experiments. Although hard copies of the displayed images are not required for the Microfiche Scanner and Remote Display System, tests were conducted to determine the growth potential of the system.

The Hard Copy Unit is a self contained unit which interfaces directly with the display terminal. The copy-making process is initiated by operating a single switch on the Hard Copy Unit or by the display keyboard.

The standard copy size is 8-1/2 inches by 11 inches. Copy time is approximately 18 seconds for the first copy and about 8 seconds for additional copies of the same display. The unit uses 3M Type 777 Dry Silver paper.

Examples of hard copy output from the unit are shown in Figures B-22 and B-23. Figure B-22 is a photograph of a hard copy taken of the zoomed image on the display terminal shown in Figure B-15. Figure B-23 is the photograph of a hard copy taken from the display during a simulation demonstration to illustrate how half-tone images would be reproduced.

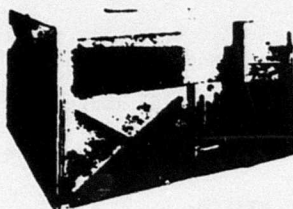

Geschirmte Kabinen u. Raumabschirmungen

Wir liefern fertige Abschirmkabinen für Laboratorien und Hochschulen, Kliniken und Krankenhäuser, Hochschulen und wissenschaftliche Institute sowie zur Abschirmung von stark strahlenden Störern. Wir liefern zerlegbare geschirmte Kabinen, deren Bauteile aus serienfertigen Normblechen bestehen, die nach dem Baukastenprinzip zusammengesetzt werden. Das Programm umfaßt drei Kabinen-Standardgrößen für Frequenzen bis 1, 10 und 35 GHz. Ein umfangreicher Katalog über Schirmungsbauteile ermöglicht es, auch Kabinen mit anderen Abmessungen zusammenzustellen. Darüber hinaus führen wir die Abschirmung vollständiger Räume unter Verwendung neuartiger Schirmungselemente durch.

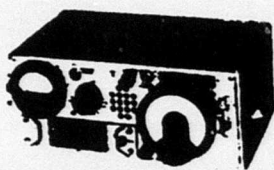

Störmeßgeräte

Störmeßgerät S 88488-A 70. Das Gerät dient zum Messen von Storspannungen im Frequenzbereich von 10 bis 150 kHz. Es entspricht den vorläufigen Empfehlungen des CISPR (676 vom April 1967).

Batterie-Störmeßgerät S 88488-B 02, ein ausschließlich mit Transistoren ausgerüstetes, aus Batterien gespeistes, tragbares Störmeßgerät für den Frequenzbereich von 0,135 bis 3,0 MHz. Es können in Verbindung mit dem Zubehör Funktorstörungen und Feldstärken gemessen werden. Das Gerät vereint in sich die Vorzüge eines hochwertigen Störmeßgerätes mit denen eines leicht transportierbaren, einfach zu bedienenden Störsuchgerätes.



Störmeßgerät S 88488-B 08, ein transistorisiertes Gerät zur Messung von hochfrequenten Storspannungen im Bereich von 0,135 bis 30 MHz. Mit geeigneten Zusatzgeräten lassen sich sowohl Storspannungen auf Leitungen aller Art, auf Antennen, an Maschinen und Anlagen als auch Storfeldstärken, z. B. von Hochspannungsanlagen (Koronamessung), industriellen und medizinischen HF-Generatoren usw. messen.

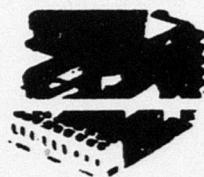

...Entstörung der einschlägigen Vorrichtungen bzw. Empfehlungen der einzelnen Länder. Im allgemeinen wird hierfür eine genaue Gerätebeschreibung mit sämtlichen für die Entstörung wichtigen Daten benötigt. In besonderen Fällen führt unsere Technische Abteilung Musterentstörungen durch, bei denen die vom Kunden anzukommenden Geräte hinsichtlich ihrer HF-Störung untersucht und für den Entstörungsprozess entsprechend...

PHOTOGRAPH OF HARD COPY
OF DISPLAYED PAGE WITH
HALF-TONE PICTURES

FIGURE B-23

B.2 SIMULATION EXPERIMENTS WITH CAMERA TUBE AND NON-STORAGE
HIGH RESOLUTION DISPLAY

In addition to the simulation demonstration using the Laser Image Processing Scanner and the Tektronix 4014 storage display, a simulation demonstration was performed using a "high resolution" TV camera tube and a high resolution, non-storage display. Since the display was a non-storage type, the simulation not only evaluated the technical performance of such a system, but also permitted determination of the extent to which "flicker" on the display caused discomfort to the viewer.

B.2.1 DESCRIPTION OF EQUIPMENT

The equipment used in this simulation consisted of the following:

Light table

Focussing lens

Cohu 1" diameter high resolution vidicon camera system

Conrac 17" high resolution monitor

B.2.1.1 Light Table. A standard photographic light table was used to illuminate the microfiche from the back. The table also served to support the fiche in a plane perpendicular to the optical axis of the lens-camera assembly.

B.2.1.2 Focussing Lens. The lens used to image a page from the microfiche onto the vidicon target was a high quality Kinoptik* photographic lens. This lens was a 50mm lens having a 100mm focal length ($f/2$).

B.2.1.3 High Resolution Camera System. The scanning system used in this simulation consisted of a Cohu** high resolution 1" vidicon camera (model #7120) and a Cohu camera control package (model #7900). The camera is reported to have an electromagnetic field emersion lens which results in higher than normal resolution and better uniformity in resolution over the face of the tube. While a center horizontal limiting resolution of 1400 TV lines reportedly can be realized with this camera, the maximum bandwidth of the camera system is 32 MHz. Consequently, the 1400 TV line center horizontal resolution can only be obtained at the expense of vertical resolution (575 TV lines).

For this simulation, the camera was operated at a 1225 line rate, 32 MHz video bandwidth and a frame rate of 30/sec.

Under these conditions, the predicted limiting resolution of the camera system was:

1000 TV lines horizontal

775 TV lines center vertical

B.2.1.4 High Resolution, Non Storage Display. The video signal from the Cohu camera was fed into a Conrac*** 17" high resolution monitor of the "RQB" series. This monitor was operated at the same rates as the camera (i.e. 1225 line rate, 32MHz video bandwidth and 30 frames/sec.).

*Kinoptik, Paris, France

**Cohu Inc., Electronics Div., San Diego, CA

***Conrac, 600 No. Rimsdale Ave., Covina, CA

B.2.2 RESULTS OF SIMULATION

A number of pages from 24X microfiche were imaged onto the vidicon target and reconstructed on the Conrac display. A photograph of one such reconstructed page is presented in Figure B-24. In order to utilize the full scan format of the camera tube (4:3 aspect ratio), the pages were scanned in a "vertical" direction (i.e. along the page height). Consequently, the pages as seen of the display were rotated 90°.

Based upon the manufacture's specification of 1000 resolvable elements per scan width (or page height), the number of "samples" for the various letter heights shown in Figure B-24 are the following:

Type #1 - 5.5 samples/letter height

Type #2 - 3.5 samples/letter height

Type #3 - 8 samples/letter height

A subjective evaluation of the corresponding legibility (or non-legibility) of these various types of letters tends to confirm the legibility criteria discussed in Section 2.4.1 of this report. That is, only the largest letters (Type #3) appear to have a sufficient number of resolvable samples to insure adequate legibility. Proportionally, more samples per page height would be required to realize good legibility of letter Types #1 and #2.

In addition to inadequate resolution in the center, the reconstructed image shows that the resolution further deteriorates along the edges of the page and particularly in the corners. The image also bows along the edges (pincushion effect). It is felt that the resolution limitations and pincushioning originated in the lens-camera portion of the system rather than at the display end.

REPORT DOCUMENTATION PAGE		READ INSTRUCTIONS BEFORE COMPLETING FORM
1. REPORT NUMBER AEIC-CR-01-7-74	2. GOVT ACQUISITION NO.	3. REPORT DATE AND NUMBER
4. TITLE (and Subtitle) USSR Dynamic Testing Capability	5. LINE OF REPORT & PERIOD COVERED	
6. AUTHOR W. E. Carleton	7. PERFORMING ORG. REPORT NUMBER	
8. PERFORMING ORGANIZATION NAME AND ADDRESS ARO, Inc. Arnold Engineering Development Center Arnold Air Force Station, Tennessee	9. CONTRACT OR GRANT NUMBER F40600-74-C-0001	
10. CONTROLLING OFFICE NAME AND ADDRESS Foreign Technology Division Wright-Patterson AFB, Ohio 45433	11. REPORT DATE June 1974	
12. DISTRIBUTION STATEMENT (to be filled in by the reporting organization)	13. NUMBER OF PAGES 17	
	14. SECURITY CLASS. of this report Unclassified	
15. STATEMENT OF RESPONSIBILITY FOR THIS REPORT This document is subject to special export controls and each transmittal to foreign governments or foreign nationals may be made only with prior approval of AEIC (DVF).		
16. SUBJECT TERMS		
17. DISTRIBUTION STATEMENT (to be filled in by the reporting organization)		
18. SUPPLEMENTARY NOTES		
19. GPO Distribution Statement (to be filled in by the reporting organization)		
20. ABSTRACT (to be filled in by the reporting organization and identify by block number) This report presents the results of a search and study of available USSR literature and patent applications pertaining to test hardware used for dynamic stability, aeroelastic flutter, and gust load testing.		

TYPE #1

TYPE #2

TYPE #3

RECONSTRUCTED MICROFICHE PAGE

FIGURE B-24

Finally, the image on the display contained a certain amount of flicker. While this flicker was not particularly noticeable when viewing the screen directly, it did become objectionable when the viewer was looking off to one side of the screen.

B.2.3 CONCLUSION

Based upon the observed legibility limitations of the system, the distortions in the image and the flicker associated with the display, it was felt that this particular camera-display system was not an acceptable candidate system for the application being studied.

APPENDIX C

DETAILED CONSIDERATION USED IN MAINTAINABILITY ANALYSIS

C.0 INTRODUCTION

Section 3.1.2.4.2 of this report discussed the Maintainability Analysis performed on the laser, flying spot and solid state array scanning systems. Certain portions of this analysis involved detailed considerations which are presented in the following section of this Appendix.

C.1 CONSIDERATIONS USED IN ESTIMATING PREVENTATIVE MAINTENANCE EFFORT ASSOCIATED WITH EACH SCANNING SYSTEM

Certain preventative maintenance tasks are common to all three scanners. These tasks and the hours required to complete each task are presented in Table C-1.

TABLE C-1

MAINTENANCE TASKS AND MAINTENANCE HOURS COMMON
TO THE
THREE CANDIDATE SCANNING SYSTEMS

Subsystem or Component	Maintenance Task	# of hours per occurrence	# of occurrences per year	# of hours per year
X-Y Table	Clean	1	12	12
	Lubricate & Adjust	8	1	8
Vacuum Pump	Replace filter, lubricate & clean	1	2	2
Printer - Keyboard	Clean	1	12	12
	Lubricate, clean & replace belt	4	1	4
Overall System	General inspection, cleaning & replacement of such items as indicator lamps	4	2	8
			TOTAL	46 hrs/year

TABLE C-2

MAINTENANCE TASKS AND MAINTENANCE HOURS UNIQUE
TO THE
THREE CANDIDATE SCANNING SYSTEMS

Subsystem or Component	Maintenance Task	# of hours per occurrence	# of occurrences per year	# of hours per year
LASER SCANNER				
Laser	Replace & align.	10	2	20
Air Compressor for Spinner Bearing	Lubricate & replace filter	2	2	4
Optical Elements	Clean	2	2	4
PMT	Replace	8	(once every <u>2</u> yrs)	4
TOTAL				32 hrs/yr.
FLYING SPOT SCANNER				
Cathode Ray Tube	Replace	20	(once every <u>2</u> yrs)	10
Optical Elements	Clean	2	2	4
PMT	Replace	8	(once every <u>2</u> yrs)	4
TOTAL				18 hrs/vr
SOLID STATE SCANNER				
Light Source	Replace bulb	1	3	3
Optical Elements	Clean	1	2	2
TOTAL				5 hrs/yr
		256		

Other preventative maintenance tasks are unique to each scanner. These tasks and the hours required to complete them are presented in Table C-2.

Combining the totals shown in Table C-1 and Table C-2, the total estimated preventative maintenance time per year associated with each scanner is:

Laser Scanner	-	78 hours
Flying Spot Scanner	-	64 hours
Solid State Scanner	-	51 hours

C.2 CONSIDERATIONS USED IN ESTIMATING CORRECTIVE MAINTENANCE EFFORT ASSOCIATED WITH EACH SCANNING SYSTEM

As discussed in Section 3.1.2.4.2 of this report, the time per year, T_{CM} , required to perform corrective maintenance tasks on each scanner can be estimated by using the formula:

$$T_{CM} = \frac{T}{MTBF} \times \bar{M}_{ct} \times f_{\ell}$$

where,

T = yearly operating time (2000 hrs assumed)

MTBF = Mean Time Between Failures (obtained from reliability data)

\bar{M}_{ct} = average replacement time, \bar{T}_r , and time required for system retest

f_{ℓ} = learning factor (taken to be "4")

In turn, \bar{T}_r can be estimated using the formula:

$$\bar{T}_r = \frac{\Sigma(\lambda_1 t_1 + \lambda_2 t_2 + \dots + \lambda_n t_n)}{\lambda_t}$$

where,

λ_t = total failures/10⁶ hrs.

λ_1 = failure rate of applicable block

t_1 = estimated time of repairing each block

The numerical analysis used to determine \bar{T}_{CM} for each of the candidate scanner is presented in Tables C-3 through C-5.

TABLE C-3

 T_{CM} ANALYSIS FOR LASER SCANNING SYSTEM

Subsystem or Component*	Failure Rate* (per 10^6 hrs.)	Estimated Repair Time (hrs)	Product
	λ	t	λt
Laser	83.0	10	830
Spinner	30.0	8	240
Control Electronics	19.5	4	78
Vacuum Pump	10.0	4	40
X-Y Table	78.8	8	630
Printer	100.0	5	500
PMT	45.0	3	135
Amplifier	36.0	3	108
Threshold Selector	45.0	4	180
"No-Signal" Detector	5.0	4	20
Growth Factor	80.0	4	320

TOTAL $\lambda = 532.3$ TOTAL $\lambda t = 3081$

$$\bar{T}_r = \frac{\text{Total } \lambda t}{\text{Total } \lambda} = \frac{3081}{532.3} = 5.8 \text{ hrs}$$

System retest time = 4.0 hrs

$$\bar{M}_{ct} = 9.8 \text{ hrs}$$

$$T_{CM} = \frac{T}{MTBF} \times \bar{M}_{ct} \times f_{\ell}$$

$$= (2000) \left(\frac{532.3}{10^6} \right) (9.8) (4)$$

$$T_{CM} = 42 \text{ hrs}$$

*From reliability data

TABLE C-4

T_{CM} ANALYSIS FOR FLYING SPOT SCANNING SYSTEM

Subsystem or Component *	Failure Rate* (per 10 ⁶ hrs)	Estimated Repair Time (hrs)	Product
	λ	t	λt
CRT Controls	140.2	3	421
CRT Package	212.0	3	636
Vacuum Pump	10.0	4	40
X-Y Table	78.8	8	630
Printer	100.0	5	500
PMT	45.0	3	135
Amplifier	36.0	3	108
Threshold Selection	45.0	4	180
"No-Signal" Detector	5.0	4	20
Growth Factor	80.0	4	320

TOTAL $\lambda = 752.0$ TOTAL $\lambda t = 2990$

$$\bar{T}_r = \frac{\text{Total } \lambda t}{\text{Total } \lambda} = \frac{2990}{752.0} = 4.0 \text{ hrs}$$

System retest time = 2.0 hrs

$$\bar{M}_{ct} = 6.0 \text{ hrs}$$

$$T_{CM} = \frac{T}{MTBF} \times \bar{M}_{ct} \times f_l$$

$$= (2000) \left(\frac{752.0}{10^6} \right) (6.0) (4)$$

$$T_{CM} = 36 \text{ hrs}$$

*From reliability data

TABLE C-5

 T_{CM} ANALYSIS FOR SOLID STATE SCANNING SYSTEM

Subsystem or Component*	Failure Rate* (per 10^6 hrs)	Estimated Repair Time (hrs)	Product
	λ	t	λt
Light Source	25.0	1	25
Vacuum Pump	10.0	4	40
X-Y Table	78.8	8	630
Printer	100.0	5	500
Power Supplies	30.0	4	120
Counter & Recorder	9.5	4	38
Array Circuits	52.0	3	156
Array	60.0	3	180
Amplifier	36.0	3	108
Read Only Memory	5.0	4	20
Threshold Selector	45.0	4	180
"No-Signal" Detector	5.0	4	20
Growth Potential	80.0	4	320

TOTAL λ = 536.3TOTAL λt = 2337

$$\bar{T}_r = \frac{\text{Total } \lambda t}{\text{Total } \lambda} = \frac{2337}{536.3} = 4.4 \text{ hrs}$$

System retest time = 2.0 hrs

$$\bar{M}_{ct} = 6.4 \text{ hrs}$$

$$T_{CM} = \frac{T}{MTBF} \times \bar{M}_{ct} \times f_l$$

$$= (2000) \left(\frac{536.3}{10^6} \right) (6.4) (4)$$

$$T_{CM} = 28 \text{ hrs}$$

*From reliability data

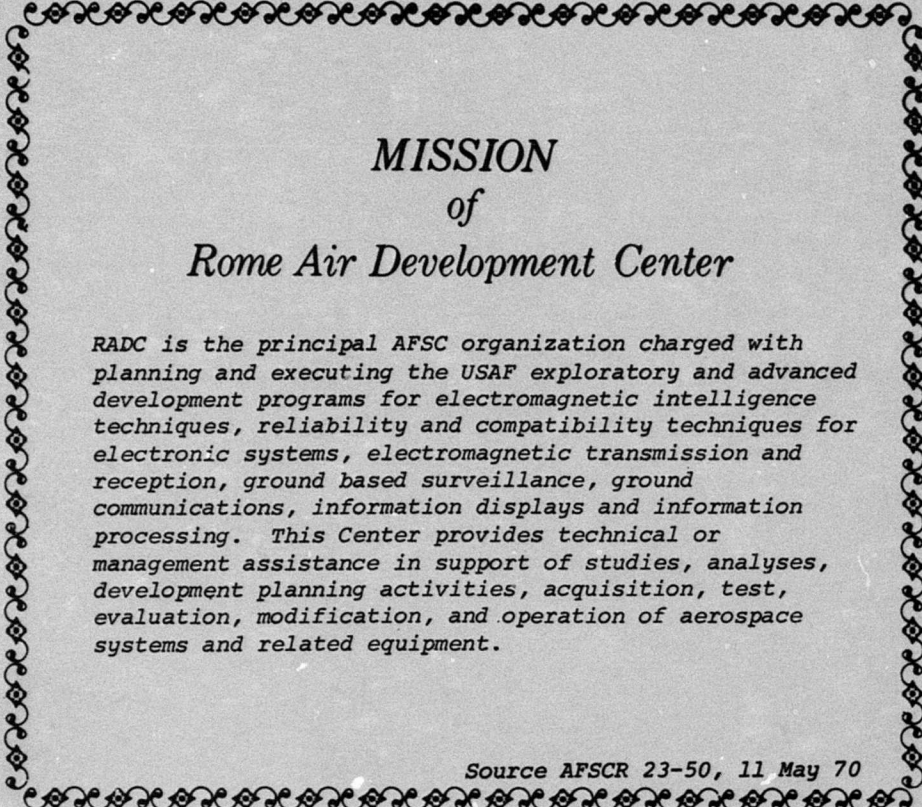
A decorative border with a repeating floral or scrollwork pattern surrounds the central text.

MISSION
of
Rome Air Development Center

RADC is the principal AFSC organization charged with planning and executing the USAF exploratory and advanced development programs for electromagnetic intelligence techniques, reliability and compatibility techniques for electronic systems, electromagnetic transmission and reception, ground based surveillance, ground communications, information displays and information processing. This Center provides technical or management assistance in support of studies, analyses, development planning activities, acquisition, test, evaluation, modification, and operation of aerospace systems and related equipment.

Source AFSCR 23-50, 11 May 70