

UNCLASSIFIED

AD NUMBER

ADB013123

LIMITATION CHANGES

TO:

Approved for public release; distribution is unlimited.

FROM:

Distribution authorized to U.S. Gov't. agencies only; Test and Evaluation; DEC 1975. Other requests shall be referred to Air Force Weapons Lab., Kirtland AFB, NM 87117.

AUTHORITY

AFWL ltr 7 Nov 1986

THIS PAGE IS UNCLASSIFIED

AD Bo 13 123

AUTHORITY:

AFWL etc.

7 NOV 86

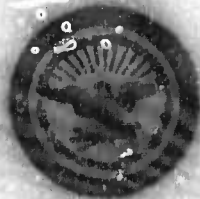

AFWL-TR-75-249, Vol. I

AFWL-TR-75-249  
Vol. I

2

ADB013123

AD No. \_\_\_\_\_  
DDC FILE COPY



# HARD PAN I TEST SERIES TEST AND INSTRUMENTATION PLANS

Volume I

Test Plan

December 1975

Final Report

Distribution limited to US Government agencies only because test and evaluation of military systems is discussed in the report (Dec 75). Other requests for this document must be referred to AFWL (DEV), Kirtland AFB, NM, 87117.

This report was sponsored by the Defense Nuclear Agency under Subtask L35JAXYX971, Work Unit 01, Work Unit Title: Construction Support for SAMSO Structure Program.

Prepared for  
Director  
DEFENSE NUCLEAR AGENCY  
Washington, DC 20305

and  
SPACE AND MISSILE SYSTEMS ORGANIZATION  
Los Angeles, CA 90009

AIR FORCE WEAPONS LABORATORY  
Air Force Systems Command  
Kirtland Air Force Base, NM 87117



DDC  
RECEIVED  
AUG 26 1976

B  
PW

This technical report was prepared for the Space and Missile Systems Organization and the Defense Nuclear Agency under Contract DNA-001-75-C-0056, Job Order 133B1412 by the Air Force Weapons Laboratory, Kirtland AFB, NM. Captain Stephen G. McGrath (DEV) was the Laboratory Project Officer-in-Charge.

When US Government drawings, specifications, or other data are used for any purpose other than a definitely related Government procurement operation, the Government thereby incurs no responsibility nor any obligation whatsoever, and the fact that the Government may have formulated, furnished, or in any way supplied the said drawings, specifications, or other data is not to be regarded by implication or otherwise as in any manner licensing the holder or any other person or corporation or conveying any rights or permission to manufacture, use, or sell any patented invention that may in any way be related thereto.

This technical report has been reviewed and is approved for publication.

  
STEPHEN G. McGRATH  
Captain, USAF  
Project Officer

FOR THE COMMANDER

  
JAMES M. WARREN  
Lt Colonel, USAF  
Chief, Facility Survivability  
Branch

  
FRANK J. LEECH  
Lt Colonel, USAF  
Chief, Civil Engineering Research  
Division

ACCESSION for	
RTIR	White Section <input type="checkbox"/>
DOC	Buff Section <input checked="" type="checkbox"/>
UNANNOUNCED	<input type="checkbox"/>
JUSTIFICATION.....	
BY.....	
DISTRIBUTION/AVAILABILITY CODES	
Dist.	Avail. and/or SPECIAL
B	

UNCLASSIFIED

SECURITY CLASSIFICATION OF THIS PAGE (When Data Entered)

19 REPORT DOCUMENTATION PAGE		READ INSTRUCTIONS BEFORE COMPLETING FORM
1. REPORT NUMBER 18 AFWL-TR-75-249-Vol-1	2. GOVT ACCESSION NO.	3. RECIPIENT'S CATALOG NUMBER
4. TITLE (and Subtitle) 6 HARD PAN I TEST SERIES TEST AND INSTRUMENTATION PLANS. I. Test Plan. Volume	5. TYPE OF REPORT & PERIOD COVERED 9 Final Report.	
7. AUTHOR(s) 10 J./Doran GE-TEMPO (DASIAE) Santa Barbara, Calif 16	6. PERFORMING ORG. REPORT NUMBER	
9. PERFORMING ORGANIZATION NAME AND ADDRESS Air Force Weapons Laboratory (DEV) AF-133B, Kirtland AFB, NM 87117 DNA-NWET	8. CONTRACT OR GRANT NUMBER(s) 15 DNA-001-75-C-0056	
11. CONTROLLING OFFICE NAME AND ADDRESS Space and Missile Systems Organization Los Angeles, CA 90009	10. PROGRAM ELEMENT, PROJECT, TASK AREA & WORK UNIT NUMBERS 11213F, 62710H; 133B1412; L35JAXYX971, 01	
14. MONITORING AGENCY NAME & ADDRESS (if different from Controlling Office) Director Defense Nuclear Agency Washington, D.C. 20305 17 14, X971	12. REPORT DATE 11 Dec 75	
	13. NUMBER OF PAGES 114 12 113 P.	
	15. SECURITY CLASS. (of this report) UNCLASSIFIED	
16. DISTRIBUTION STATEMENT (of this Report) Distribution limited to US Government agencies only because test and evaluation of military systems is discussed in the report (Dec 75). Other requests for this document must be referred to AFWL (DEV), Kirtland AFB, NM, 87117.		
17. DISTRIBUTION STATEMENT (of the abstract entered in Block 20, if different from Report)		
18. SUPPLEMENTARY NOTES This report was sponsored by the Defense Nuclear Agency under Subtask L35JAXYX971, Work Unit 01, Work Unit Title: Construction Support for SAMSO Structure Program.		
19. KEY WORDS (Continue on reverse side if necessary and identify by block number) Nuclear weapons effects; Airblast; Structure response; Ground shock; Silos; Nuclear weapons simulation; Launch facilities; High-explosive tests; Structure medium interaction (SMI)		
20. ABSTRACT (Continue on reverse side if necessary and identify by block number) The objectives, test configurations, and instrumentation implementation of the HARD PAN I test series are presented in three volumes. Volume I describes the high-explosive test events (5 major and 13 calibration events) performed to obtain experimental measurements of the shock environment in the vicinity of a test structure in a layered geology due to a simulated near-surface nuclear detonation. The test geology was clay over interbedded limestone and shale. Structure medium interaction (SMI) data obtained in the test series is to be used in development of prediction codes for use in analyses relating to facility		

NEW  
[Handwritten signature]

Cont

UNCLASSIFIED

SECURITY CLASSIFICATION OF THIS PAGE(When Data Entered)

design, modification, and hardness validation and/or assessment. Berm-loaded explosive simulation technique (BLEST), a new technique for high-explosive simulation of nuclear detonation effects, is described. The first use of BLEST was in the HARD PAN I series where it augmented the more precise HEST used to provide direct airblast loading, and increased total simulation times at acceptable additional cost. Volume I also includes specific operational plans (safety, communications, security) and data analysis requirements. Volume (Appendix P) describes the instrumentation systems used to obtain motion, stress, and strain data from free-field and structure locations in the first three major events and the calibration events. Measurements lists are included. Volume III (Appendix P, continued) describes the instrumenting of the final two major events and lists all measurements.

UNCLASSIFIED

SECURITY CLASSIFICATION OF THIS PAGE(When Data Entered)

## CONTENTS

## Volume I

<u>Section</u>		<u>Page</u>
I	INTRODUCTION	5
	1. The SMI Program and HARD PAN I	5
	2. Test Program Implementation	8
	3. Location of HARD PAN I Test Site	9
II	TEST REQUIREMENTS	13
	1. Test Objectives	13
	2. Criteria for Success of Tests	13
III	DESCRIPTION OF TESTS	15
	1. HARD PAN I-1	15
	2. HARD PAN I-2A	23
	3. HARD PAN I-2B	35
	4. HARD PAN I-3	41
IV	ADDITIONAL CALIBRATION EVENTS	46
	1. Requirement for Tests	46
	2. Calibration Test Objectives	46
	3. Test Schedule	46
	4. Test Locations	46
	5. Test Descriptions	48
V	PROGRAM MANAGEMENT	52
	1. Test Direction	52
	2. Organization	52
	3. Task/Subtask Responsibilities	52
VI	TEST SCHEDULE	56
	APPENDIXES	
	A Security Classification	59
	B Security Plan	60
	C Safety Plan	63
	D Communication Plan	71
	E SAMS0/AFWL Agreement	74
	F Photo Plan for Project HARD PAN I	81

## CONTENTS (Continued)

<u>Section</u>	<u>Page</u>
APPENDIXES (Continued)	
G Environmental Effects Monitoring	83
H Test Arming and Firing Checklist	85
I Hold Conditions and Procedures	88
J Misfire Procedures	93
K Data Reduction and Analysis	94
L Pre- and Post Test Model Survey	97
M The BLEST Concept	98
N Meteorological Support Plan	106
O Report Requirements	108

## ILLUSTRATIONS

<u>Figure</u>		<u>Page</u>
1	Outrunning Ground Shock Phenomena	7
2	Location of HARD PAN I Test Site	10
3	HARD PAN I-1 Geologic Profiles	16
4	HARD PAN I-1 Site Layout	17
5	HARD PAN I-1 HEST Construction	18
6	Detonating Cord Fishnet Weave as Installed in HARD PAN I-1 HEST	20
7	HARD PAN I-1 Geometry and Construction Details	22
8	HARD PAN I-2A Site Layout	24
9	HARD PAN I-2A Geologic Sections	25
10	Physical Layout for HARD PAN I-2A	26
11	HP I-2A Configuration versus Preliminary HP I-3 Design	27
12	HP I-2A BLEST Charge Emplacement	29
13	HP I-2A BLEST Array Firing System Trunk Lines	30
14	HP I-2A BLEST Firing System Grid	31
15	HARD PAN I-2A HEST Construction Details	32
16	Geometry of HARD PAN I-2A Structure	33
17	Plan View of HP I-2B Test Site	36
18	HARD PAN I-2B Geologic Sections	37
19	Elevation View - HP I-2B BLEST Field	38
20	HARD PAN I-2B BLEST as Part of Revised HP I-3 BLEST Design	39
21	Geometry of HARD PAN I-2B Structure	42
22	HARD PAN I-3 Geologic Sections (HEST Area)	43
23	Geometry of HARD PAN I-3 Structure	45
24	Location of Calibration Events	49
25	HP I SCAL Calibration Test Configurations	50
26	HARD PAN I Program Responsibilities	53
27	HARD PAN I Timetable	57

## TABLES

<u>Table</u>		<u>Page</u>
1	HARD PAN I-1 Instrumentation	21
2	BLEST Charge Parameters-HARD PAN I-2A	23
3	Decoupled BLEST Holes	28
4	HARD PAN I-2A Instrumentation	34
5	BLEST Charge Parameters - HARD PAN I-2B	40
6	HARD PAN I Calibration Tests	47

SECTION I  
INTRODUCTION

1. THE SMI PROGRAM AND HARD PAN I

The HARD PAN I test program is a series of field tests conducted by the Air Force Weapons Laboratory (AFWL) and sponsored by the Space and Missile Systems Organization (SAMSO) and the Defense Nuclear Agency (DNA). HARD PAN I is the field test portion of the SAMSO Structure Medium Interaction (SMI) program. The SMI program is a multi-year integrated effort whose ultimate purpose is to develop the prediction techniques needed to evaluate the response of buried facilities to the effects of nuclear detonations. Structure medium interaction data collected and the computer codes developed will substantially increase the capability to perform analyses relating to facility design, modifications, hardness validations or assessments, as required.

The primary issue to be addressed in the SMI program is the investigation of the phenomenology of structure medium interaction. The development of prediction codes possessing the desired measures of accuracy and confidence requires that a considerable effort be devoted to strengthening their phenomenological base. The HARD PAN series of high explosive test events is designed to provide experimental data in support of this effort.

The HARD PAN I tests will provide experimental measurements of the shock environment, due to a simulated near surface nuclear burst, in the vicinity of a test structure in a layered geology. The tests will be performed in a geology characterized by a layer of clay over a competent rock layer composed of interbedded limestone and shales. Certain portions of the test structures will penetrate the competent rock layers, while other portions will be entirely in the clay overburden.

Of interest also are the characteristics of the shock waves through this particular geology due to the passage of an airblast across the surface. The tremendous pressures developed by a nuclear detonation give rise to a blast wave which propagates radially outward at a very high, but decreasing, velocity.\* When the shock front from a near surface burst encounters the earth surface, a reflected shock wave is produced in the air. There is also shock wave energy transmitted into the earth, resulting in what is termed "airblast induced ground shock". Prediction and/or analysis of the resulting ground motions and stresses is complicated by the fact that the material properties of the media, including propagation velocities, are difficult to establish without extensive geophysical investigation. Seismic velocities for example, vary widely from one medium to another.\*\*

\*For a 1 MT detonation at sea level typical velocities are (approximately):  
14,000 fps at 1000 ft range, 8600 fps at 1500 ft, 6000 fps at 2000 ft range,  
and 1900 fps at 5000 ft range.

\*\*For the HARD PAN I test site, seismic velocities vary from about 1600 fps  
in clay soil to 18,000 fps in competent limestone.

Figure 1 illustrates, for several instants in time, the wave front associated with a near surface burst over a particular layered media. The upper medium, clay, has a relatively low seismic velocity: the lower medium, interbedded limestone and shale has much higher seismic velocities. A downward propagating shock wave is formed in the upper medium due to the interaction of the airblast shock wave with the medium (left portion of figure). This shock wave propagates at the seismic velocity of the medium; its direction of propagation is determined by both the seismic velocity  $c_1$  and the velocity  $u$  of the airblast shock wave across the surface. When the shock wave in the upper medium impinges on the lower medium a shock wave is formed which travels at higher velocity  $c_2$  in that medium. The propagation velocity is peculiar to the medium and is independent of the airblast propagation velocity.

At some range from detonation ground zero the airblast shock front will have slowed to a velocity less than the seismic velocity in the lower medium (middle portion of figure 1). Beyond that range the shock front in the lower medium is travelling faster than the airblast and can arrive at the target structure coincident with the airblast arrival or even earlier (right hand portion of figure 1). It is the intent of the HARD PAN I tests to obtain data for the situation in which the arrivals of both the direct airblast and the airblast induced outrunning ground shock are coincident. It is this situation which can give rise to a much more severe shock environment than that due to either the direct airblast or the airblast induced ground shock alone. It could possibly be more severe than might be predicted by a straightforward summation of the effects of the two.

There are presently little quantitative data relating to the combined effects of direct airblast and airblast induced ground shock. This lack of data places restraints in the way of the development of prediction codes. The HARD PAN I tests are designed to provide data to evaluate these combined effects\* and to contribute to prediction code development. Among the questions to which the HARD PAN I tests may provide answers is that relating to the degree to which a detailed knowledge of the subsurface geology in the neighborhood of a buried facility is required for credible predictions.

The HARD PAN I tests will comprise four major explosive events and a number of minor calibration events. The final event will include a test structure approximately half the size of a missile launch facility. Structures employed in the earlier events are for the purpose of verifying the instrumentation procedures to be used for the final event. The nuclear environment will be simulated with conventional explosives using a method designated as HEST (High Explosive Simulation Technique). The HEST will be used directly over the test structure and will be augmented by a developmental simulation technique in nearby regions. The simulation development portion of the HARD PAN I program will be supported by the Defense Nuclear Agency.

---

\*Ground shock effects due to cratering will not be addressed in these studies. Nuclear heights of burst (HOB) will be taken to be high enough that cratering does not occur.

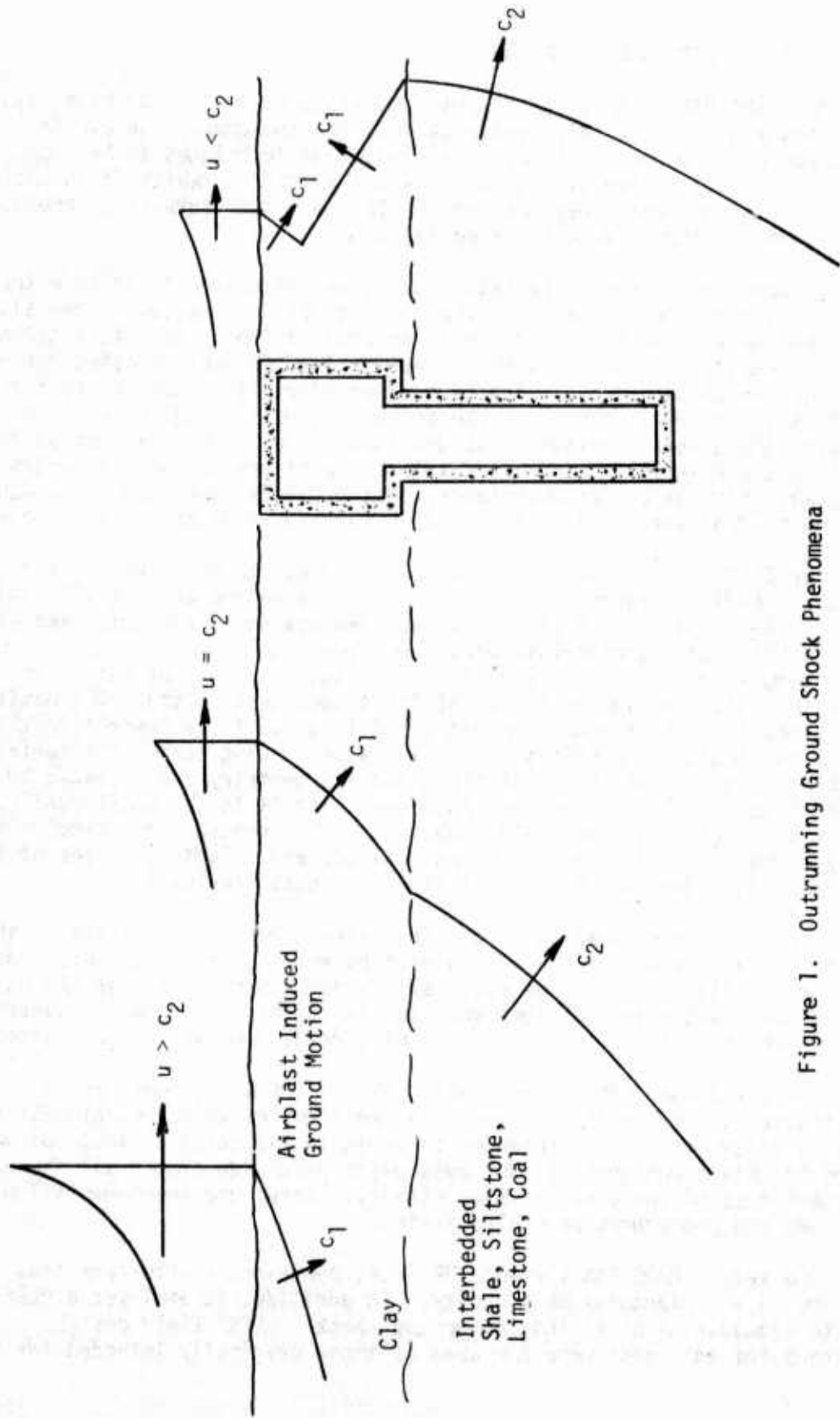

Figure 1. Outrunning Ground Shock Phenomena

## 2. TEST PROGRAM IMPLEMENTATION

The HARD PAN I (HP I) test series consists of four major high explosive (HE) events and approximately twelve calibration and comparison events. The first three major events will test the simulation techniques to be employed in the final event. They will also check the methods by which it is planned to make stress and motion measurements in the test structure, its immediate vicinity, and in the surrounding free field.

In order to economically extend the simulation area to include the outrunning ground shock effects at the test structure location, a new simulation technique was developed for use in several of the tests. This technique, designed to deliver into the earth an impulse loading approximating, for early times, that which would result from a nuclear airblast, received its first major test in the HP I-2A event. The technique, designated BLEST (Berm Loaded Explosive Simulation Technique), was developed as an economical method for simulating the effects of airblast loading on portions of the test areas where a less exact simulation was acceptable. The BLEST is thus used to augment the more precise HEST and increase the total simulation time at an acceptable cost.

The BLEST subjects a broad area surrounding the HEST area to a distributed impulse loading through the detonation of a large number of small explosive charges. These charges, of various sizes, are spaced in an array, and either placed in holes at predetermined depths or covered with a calculated depth of surcharge material, or both. The size, spacing, and depth of burial of the charges in a given region of the BLEST field combine to produce the desired average impulse. The charges are detonated in a carefully controlled time sequence to simulate the effect of a blast wave passing across the surface of the earth. The size of the BLEST field and its geometry are dictated by the required edge-free simulation time envelope. Inputs to the BLEST configuration calculations include weapon yield, HOB, range from ground zero, simulation scaling, simulation time, and detailed geologic and seismic profiles of the test area. (See Appendix M for details of the BLEST design.)

Direct airblast loading of the test structure and a portion of the surrounding earth surface will be achieved by means of the HEST which has been used successfully on many large scale simulation experiments over the past ten years. A well designed HEST configuration is capable of producing overpressure waveforms which closely reproduce those of a nuclear burst for early times.

The first HARD PAN I event, HARD PAN I-1 (HP I-1), contained a silo-type test structure, surface-flush mounted in the floor of an octagonal HEST cavity. It was an axisymmetric test intended to evaluate 2-D calculations. Of major concern in this experiment was the peak overpressure developed and the decay characteristics of the pressure-time history. Structure instrumentation techniques and procedures were also tested.

The second HARD PAN I event, HP I-2A, contained a silo-type test structure in a rectangular HEST cavity. In addition, it employed a BLEST field to simulate airblast induced ground shock. BLEST field design parameters for this test were the same as those originally intended for the

main test event, except that the overall area was reduced by a factor of approximately four, yielding a resultant edge-free simulation time of 18 ms. A major purpose of this event was to field test the BLEST concept and to evaluate the design calculations. It also demonstrated the nature and magnitude of the HEST and BLEST interaction effects. The structure instrumentation procedures received a further test.

The third major HARD PAN I Event, HP I-2B, will be similar to event HP I-2A in overall design. It will employ a larger structure, and the HEST and BLEST arrays will be redesigned to incorporate information from the HP I-2A event and the added calibration events run between 2A and 2B. This information relates primarily to the BLEST area loading parameters. Some changes will also be made in the HEST design to yield varying airblast pressure and propagation velocity from one end of the array to the other to reflect changing airblast propagation velocities (see footnote p. 8).

The final HARD PAN I event, HP I-3, will include a large silo-type structure in order to obtain structure medium interaction information useful for analysis purposes and the development of interaction relationships. The HEST and BLEST arrays for this event will be designed to simulate the scaled airblast and ground shock environment due to a 1 MT burst at 420 ft HOB and 1450 ft range. The overall size of the BLEST field will be determined to obtain 30 ms of simulation time before edge effects.

All of the HARD PAN I events will be heavily instrumented. Measurements will be made of structure strains, structure motions (velocity and acceleration), structure/medium interface stresses, soil stress, airblast pressure, and free field motions. Extensive photographic coverage will be provided to obtain information on HEST surcharge motions and dispersal, and the uplifting of the BLEST field overburden. The BLEST overburden information is important for determining the actual impulse delivered to the earth. In addition, cameras will be placed internal to the structure to record the relative motions of its parts.

### 3. LOCATION OF HARD PAN I TEST SITE

The HARD PAN I test area site is located in east-central Kansas, 62 miles south of Kansas City and 2 miles west of the Missouri border. It is in Linn County, in the southwest quarter of Section 3, T21S, R25E. Geographical coordinates are 38°15'N latitude and 94°39'W longitude. Figure 2 shows the site location.

The area in which the test site is located is largely devoted to farming, with surface coal mining activity within 10 miles to the north. Nearby population centers are: Trading Post (pop. 50), slightly over a mile to the west of the site; Pleasanton (pop. 1098), approximately 5 miles SSW; and Fort Scott (pop. 8967), 27 miles south.

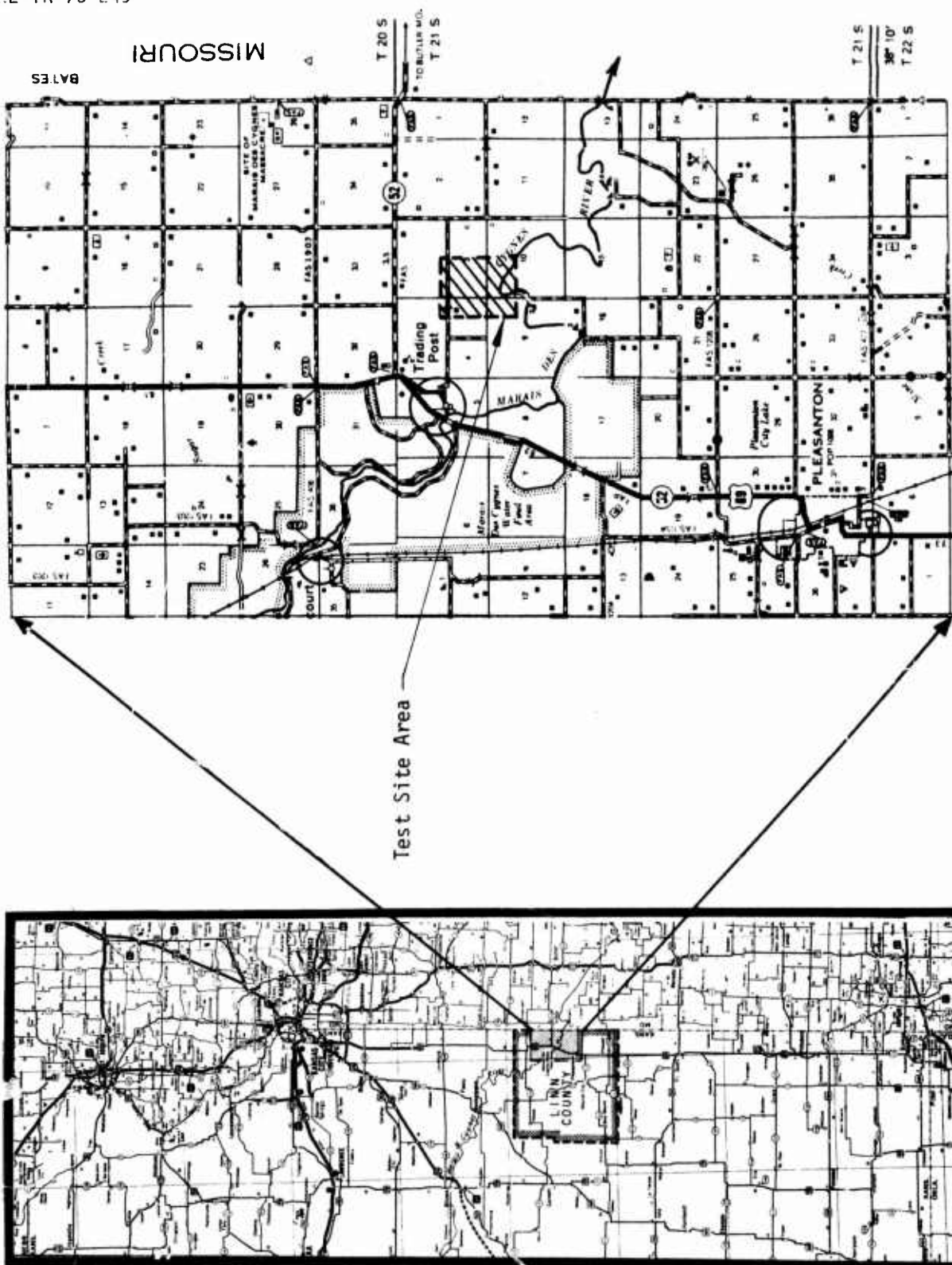

Figure 2. Location of HARD PAN I Test Site

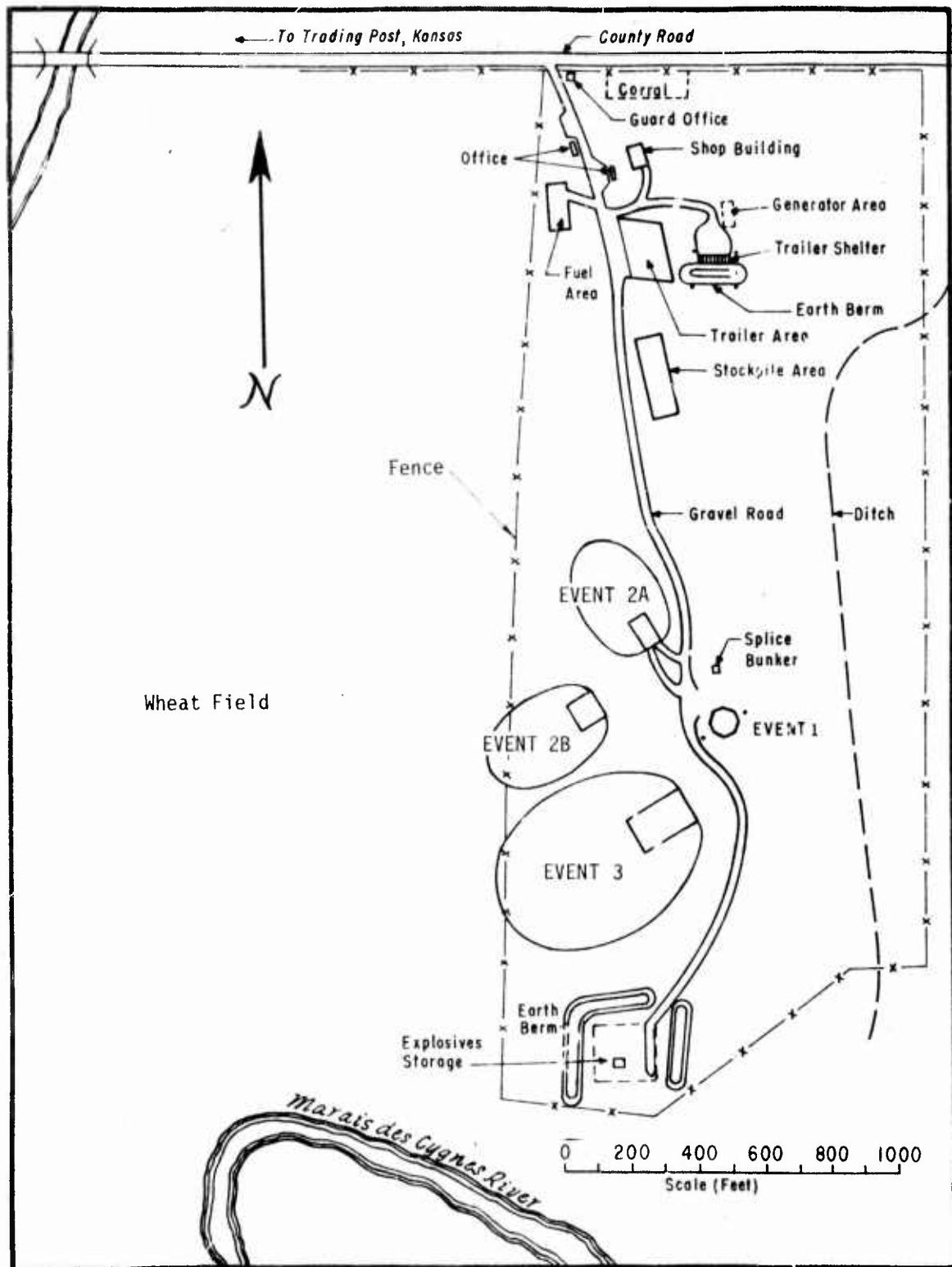

Figure 2. Location of HARD PAN I Test Site (Continued)

The test site is quite flat with elevations ranging from approximately 780 to 797 ft. The test area is located within a geomorphic region commonly referred to as the unglaciated claypan prairie and prairie sandstone. The exposed bedrock of the area surrounding the test site consists of formations of the Pennsylvanian System, Lower Missourian and Desmoinesian series, Pleasanton and Marmaton groups, composed predominantly of shale and limestone with several workable coal beds. The entire Pennsylvania sedimentary strata dips gently westward. The test site is geologically of the Marmaton group, with predominant limestone units and the Mulberry coal bed. The subsoil at the test site is a fat clay. The test site area and the environmental effects of the test series are described in some detail in the HARD PAN Environmental Assessment.\*

---

\*Gould, K.E., et al, "Environmental Effects of HARD PAN I Test Series", Air Force Weapons Laboratory Technical Report AFWL-TR-74-202, Kirtland AFB, NM, July 1974

SECTION II  
TEST REQUIREMENTS

1. TEST OBJECTIVES

The HARD PAN I series of tests is a field test program in support of the SAMSO SMI Program which has as its goal the development of accurate prediction techniques to determine facility response in a nuclear detonation environment. Specific technical objectives of the SMI Program are to:

- a. Evaluate 2-D prediction techniques
- b. Develop 3-D prediction techniques
- c. Develop facility subsystem response predictions
- d. Study air-induced outrunning ground shock (a free field ground motion phenomenon)

The first HARD PAN I event, HP I-1, will provide data in support of objective a. The second and third events, HP I-2A and HP I-2B, are primarily tests of the simulation techniques and parameters to be used in the final event, but on a smaller scale. The final event, HP I-3, is intended to yield data which will contribute to accomplishing objectives b, c and d.

2. CRITERIA FOR SUCCESS OF TESTS

a. HARD PAN I-1

The HP I-1 event will be considered successful if:

- (1) Overpressure measurements in the HEST cavity support pretest predicted peak pressures and predicted pressure decay rates, and
- (2) The percentage of recoverable data from the fielded instrumentation is high enough to enable meaningful 2-D code evaluations.

b. HARD PAN I-2A and 2B

The HP I-2 events will be considered successful if:

- (1) Sufficient data are recovered from these tests to field a high confidence simulation for the final event. This may take the form of verifying the existing design, or it may point to a requirement for redesigning the test in one or more of its aspects, and,
- (2) These first large scale tests of the BLEST concept yield data which demonstrates its utility in generating a reasonable simulation of air induced ground shock over a period of tens of milliseconds.

c. HARD PAN I-3

Success of the final event rests on the following:

- (1) A sufficiently high percentage of data of good quality is obtained so that the test results can be used in validation of 3-D codes.
- (2) SAMSO's capability to derive credible subsystem response is enhanced as a result of the data collected.
- (3) The data lead to an understanding of the structure/medium interaction phenomenology in clay over interbedded shale and limestone media.

SECTION III  
DESCRIPTION OF TESTS

1. HARD PAN I-1

a. General Test Configuration

The first event in the HARD PAN I test series is an axisymmetric test of the HEST airblast loading technique design proposed for each event of the series. In this first test an axisymmetric silo-type structure was subjected to the blast environment generated by a HEST-type simulator. The test was conducted in a part of the test area having a geologic stratigraphy resembling that for the final event except that its scale was approximately one-half in vertical dimensions. Figure 3 shows the geologic stratigraphy chosen for the HP I-1 event. The physical layout of the test is shown in figure 4. Specific aspects of the test and its configuration are described in the following sections.

b. HEST Configuration

Since the HP I-1 test was to be axisymmetric the ideal shape for the HEST cavity would have been circular. However, to decrease construction time the HEST cavity was made octagonal. The depth of cavity, 3 ft; density of explosive loading, 0.318 lb of PETN per ft<sup>3</sup>; and surcharge loading, 500 lb per ft<sup>2</sup> or approximately 4.5 ft depth, were calculated to yield an overpressure environment similar to that at the 1200 psi range from the detonation of a 125 kT nuclear device. The horizontal size of the HEST cavity was chosen to give 18 ms of simulated environment before edge effects show up. Figure 5 shows some of the construction details of the HEST configuration.

In previous HEST tests the detonating cord used to explosively load the cavity was wound on wooden racks (at a specified weave angle to control blast wave propagation velocity) in an assembly area external to the cavity. These racks were then placed in the cavity in a specified configuration to obtain the desired propagation characteristics. This method introduced what seemed to be an excessive amount of extraneous material in the cavity. A new method has been devised for deploying the detonating cord in a HEST cavity. This method employs a three-dimensional "fishnet" weave. The HP I-1 event tested it on a relatively large scale for the first time. Figure 6 shows the as built HP I-1 HEST cavity with detonating cord installed.

Detonation of the explosive in the HEST cavity was initiated simultaneously at three elevations down the center of the array. The direction of propagation of the blast wave was outward from the center of the array.

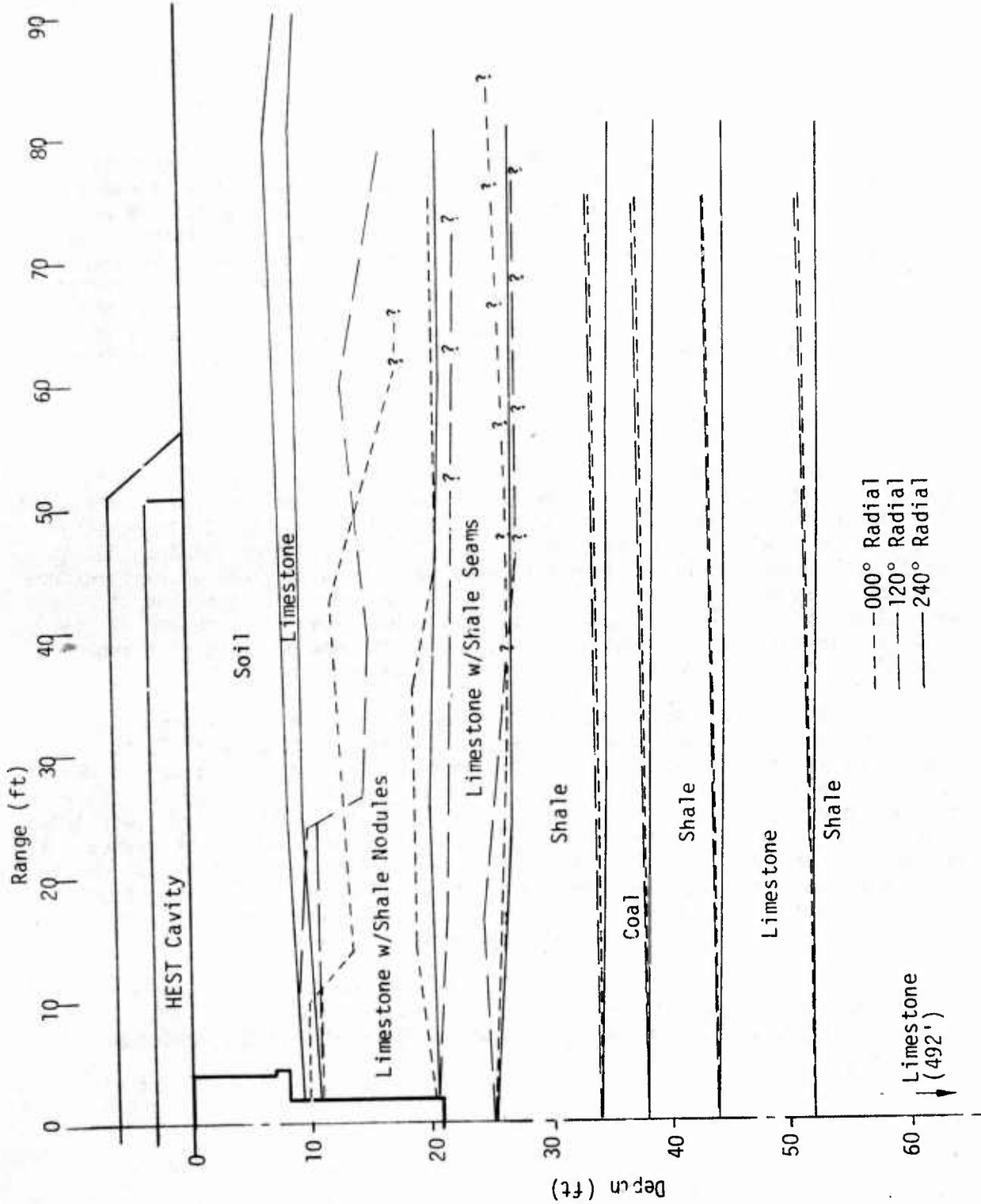

Figure 3. HARD PAN I-1 Geologic Profiles

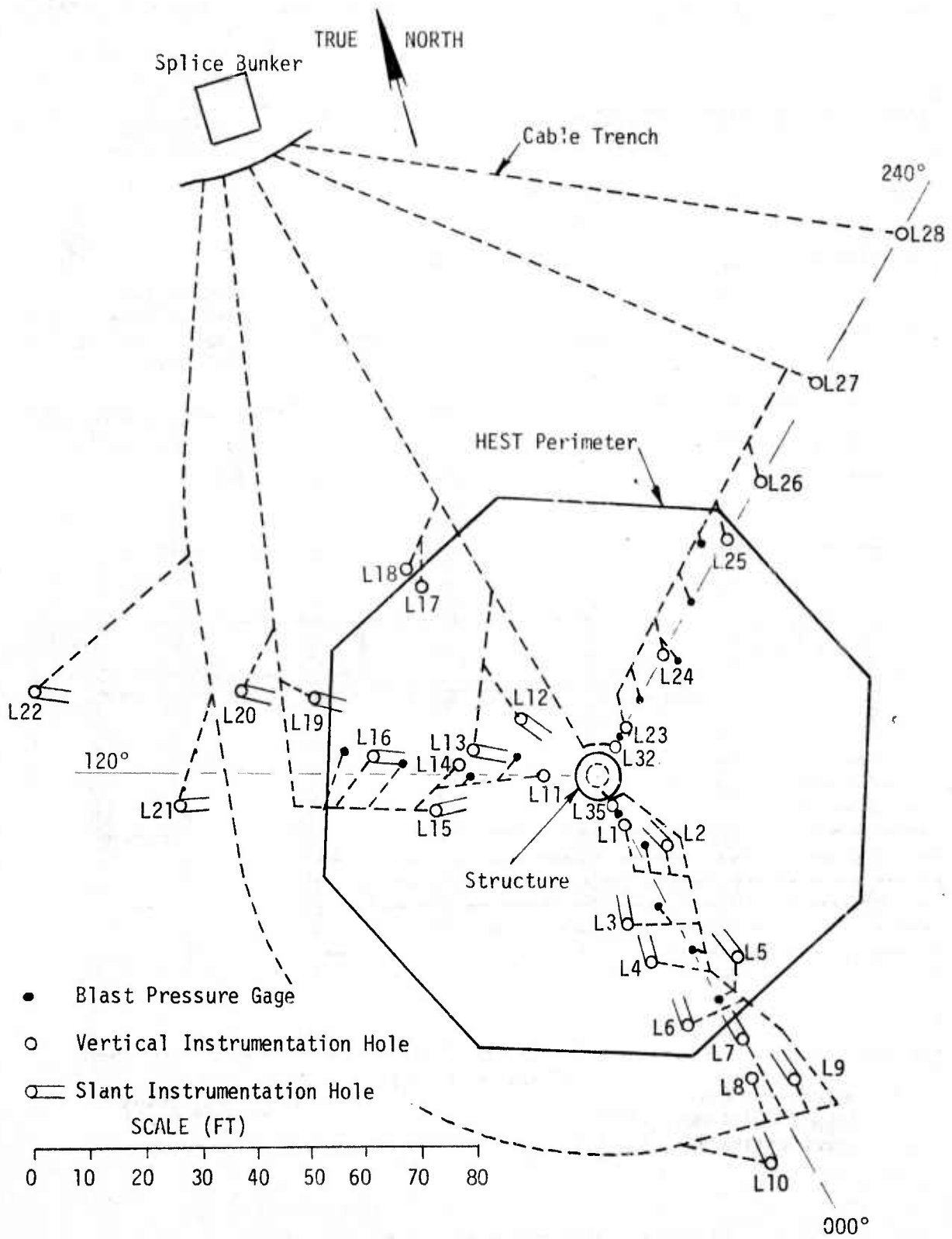

Figure 4. HARD PAN I-1 Site Layout

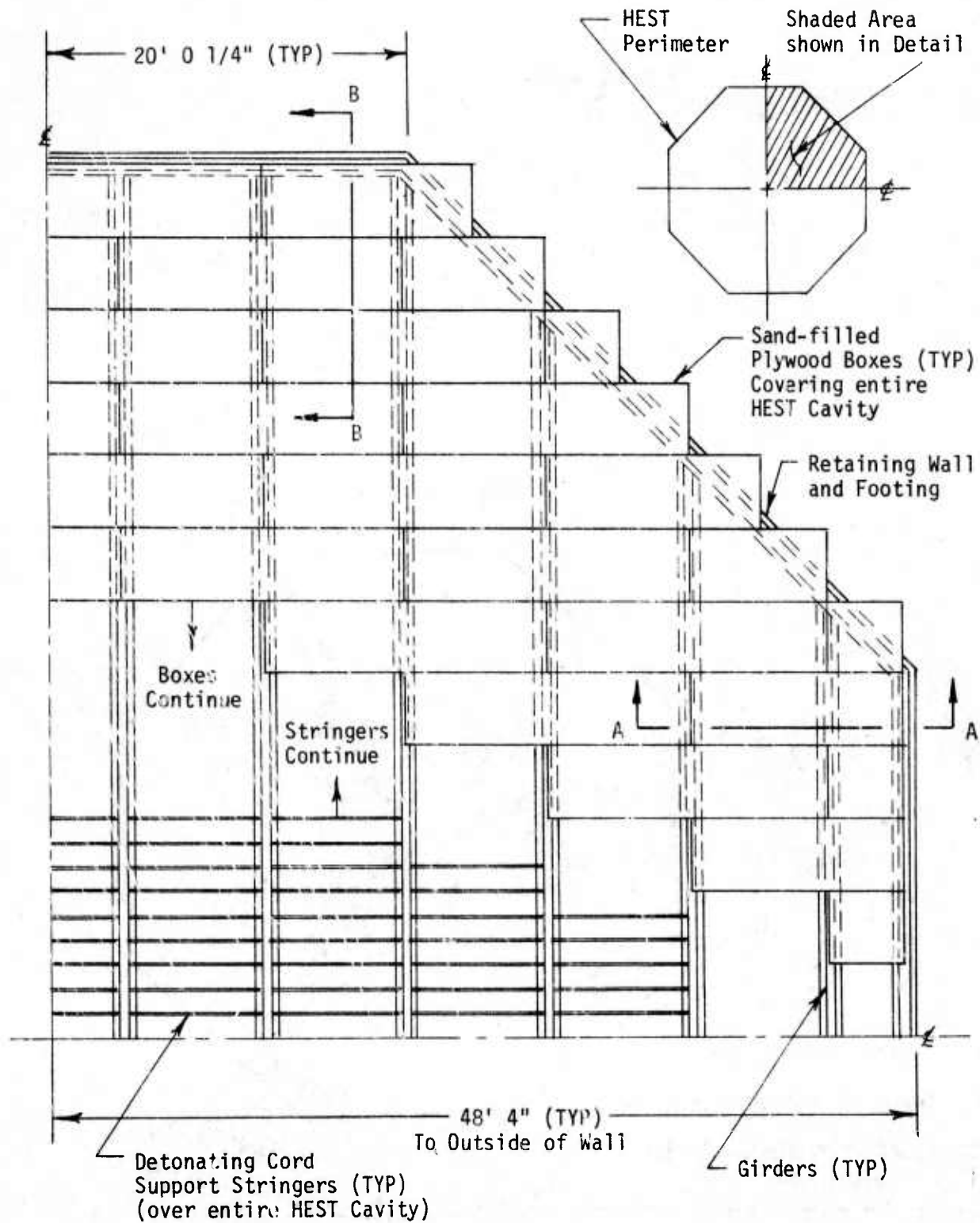
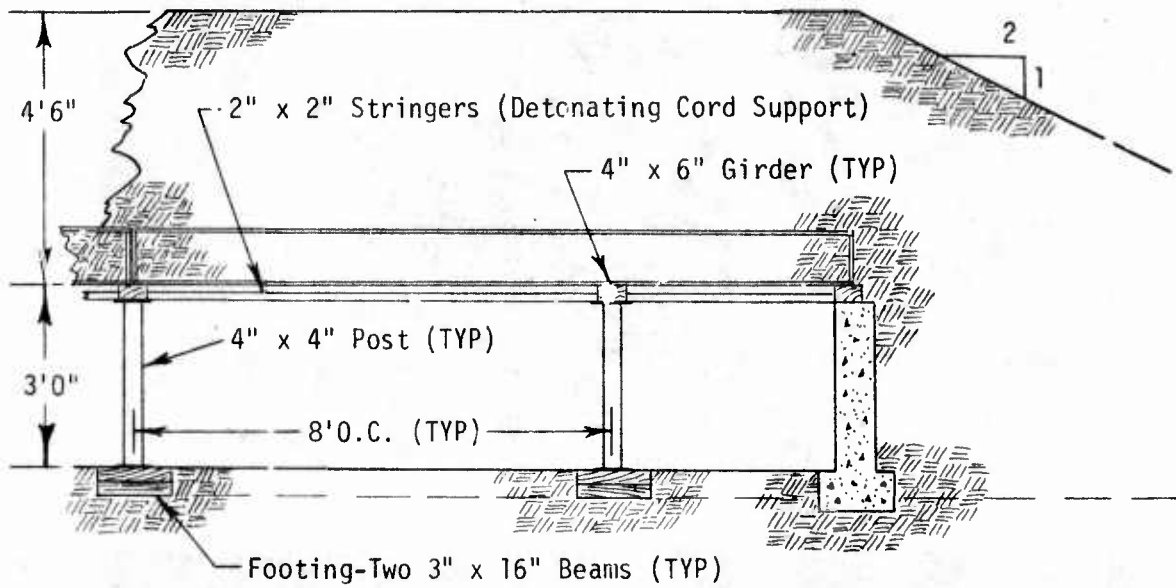
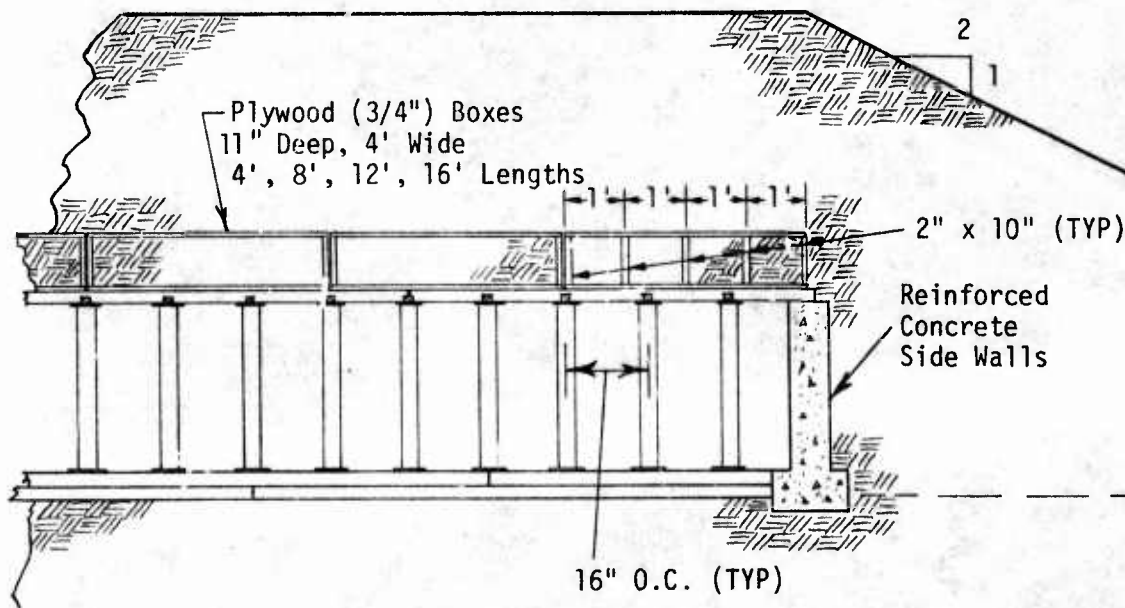

Figure 5. HARD PAN I-1 HEST Construction



Section A-A



Section B-B

Figure 5. HARD PAN I-1 HEST Construction (Continued)

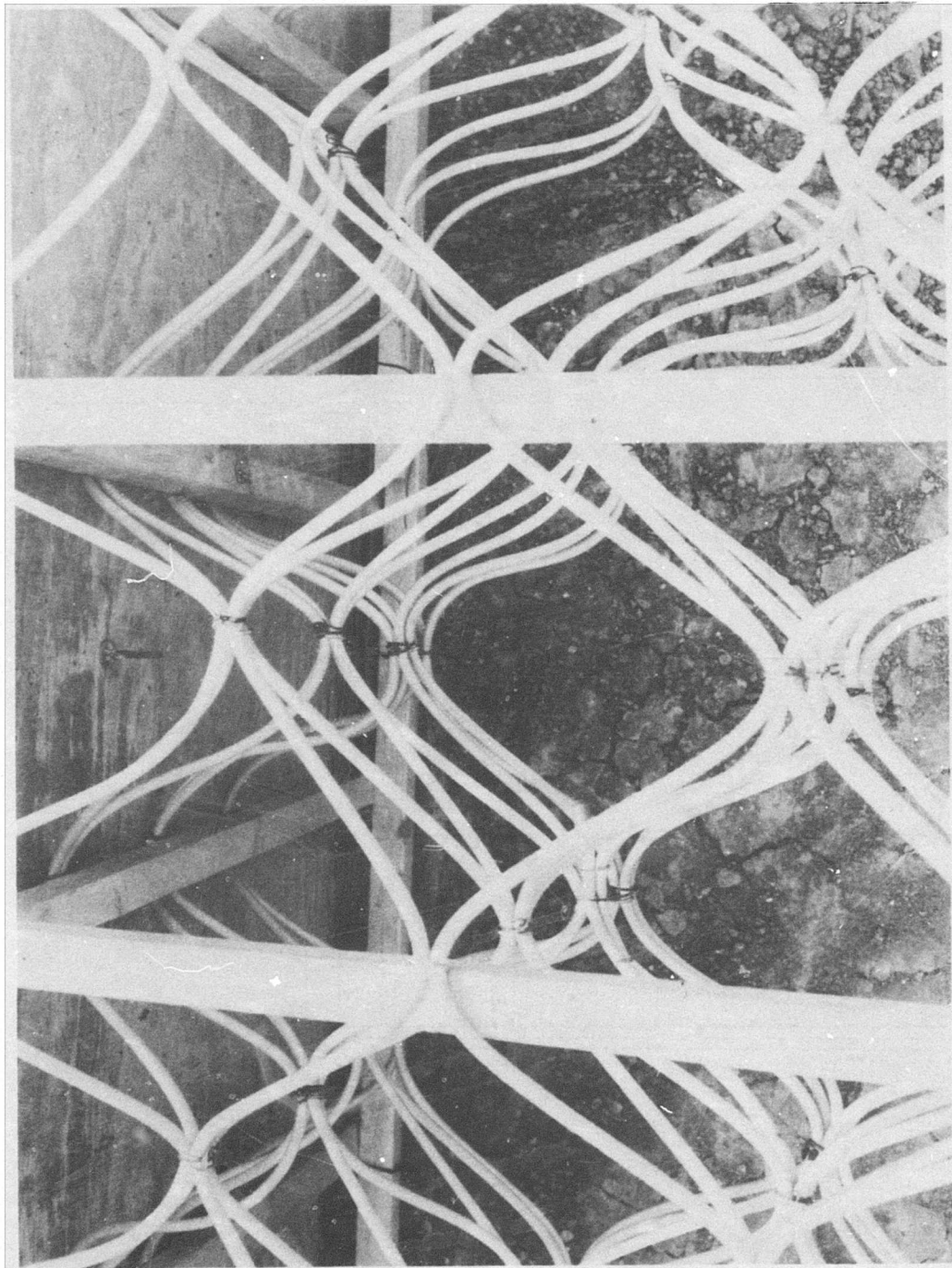

Figure 6. Detonating Cord Fishnet Weave as Installed in HARD PAN I-1 HEST

## c. Test Structure

The test structure was constructed by Waterways Experiment Station (WES) according to design specifications drawn up by the AFWL. These specifications included strain gage locations and other transducer mounting hardware to be built into the structure.

Figure 7 shows the configuration details of the HP I-1 test structure.

## d. Instrumentation

Three hundred active instrumentation transducers were fielded in the HP I-1 event. These transducers sensed blast pressure, acceleration, velocity, stress, and strain at various locations in the structure, its immediate vicinity (the near field), and the free field. Table 1 summarizes the instrumentation for the event.

Table 1. HARD PAN I-1 Instrumentation

	Structure	Structure/Medium Interface	Near Field	Free Field
Blast Pressure	6			14
Acceleration	31		26	86
Velocity	7			20
Relative Velocity		3		
Relative Displacement	4			
Rebar Strain	67			
Stress-Normal		21	12	
Stress-Shear		3		
Sub Totals	115	27	38	120
Total Active	300			

In addition to the active instrumentation, a variety of passive gages were used to measure relative displacements of the structure parts with respect to each other, relative displacement of the structure with respect to the surrounding medium, and deformation of the near field soil.

Details of the HP I-1 instrumentation plan, including specific locations at which measurements will be made, are contained in Appendix P (Vol. 2)

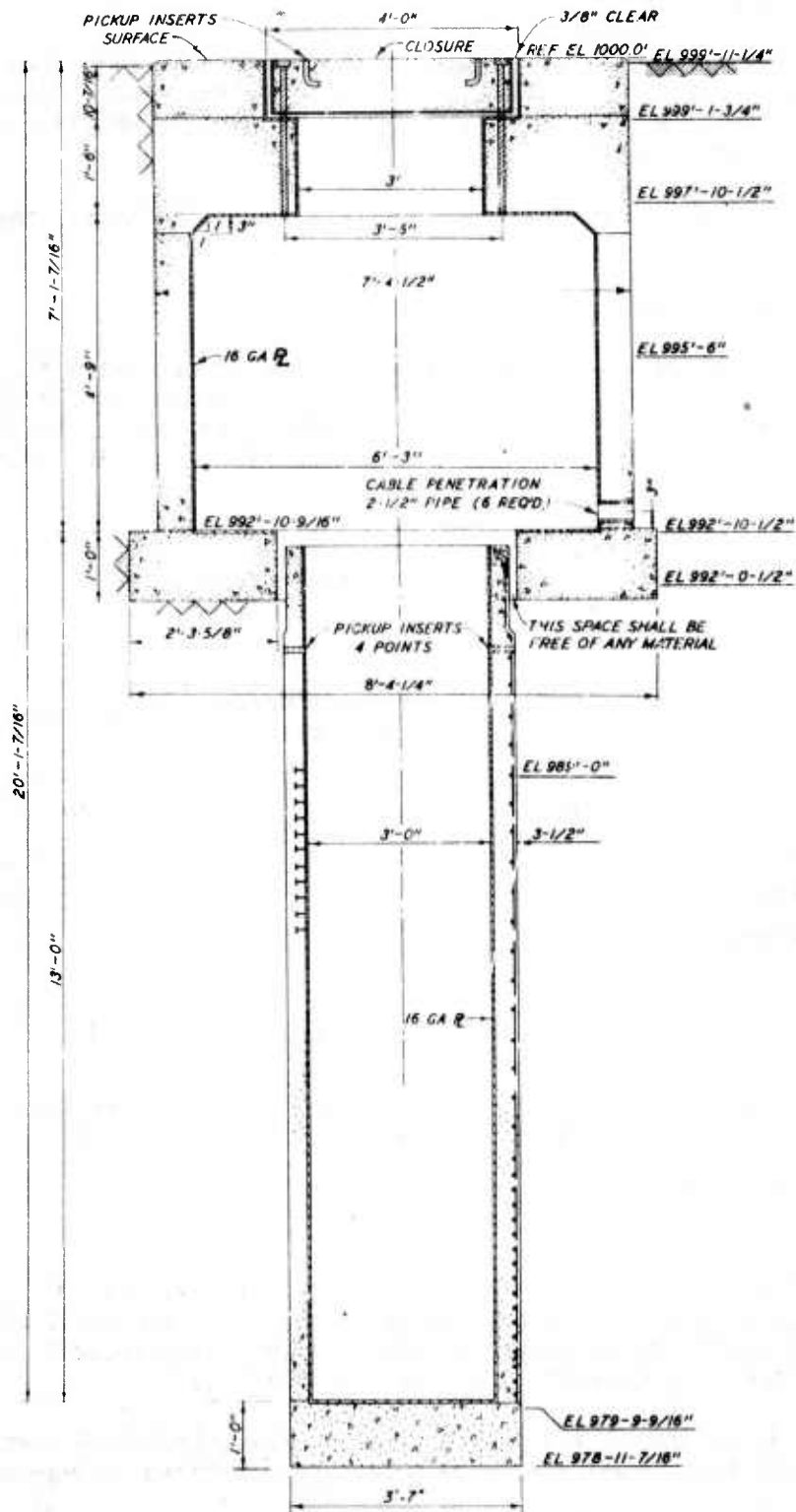

Figure 7. HARD PAN I-1 Geometry and Construction Details

## 2. HARD PAN I-2A

## a. General Test Configuration

The HP I-2A event detonated a BLEST field in conjunction with a HEST to simulate the environment at a range of 725 ft from the detonation of a 125 kT nuclear device at 210 ft HOB. Figure 8 shows the physical layout of the test event. The geologic stratigraphy of the selected test site is shown in figure 9.

## b. BLEST Configuration

For the HP I-2A event the BLEST field encompassed an area of approximately 50,000 ft<sup>2</sup>. Some 1137 individual explosive charges totalling 30.9 tons were placed at depths of 8.35 and 6.63 ft below the surface. Each consisted of 50 or 100 lb of ammonium nitrate slurry. Sizes, spacings, and depths were calculated to yield average specific impulses commensurate with the desired simulation time and yield. The simulation time for this event was 18 msec.

Figure 10 shows a plan view of the BLEST field. The area was divided into distinct zones within which charges of equal size were uniformly spaced to produce a uniform impulse loading. Table 2 lists the charge parameters for each of the HP I-2A BLEST zones.

Table 2. BLEST Charge Parameters-HARD PAN I-2A\*

Zone	Impulse (psi-sec)	Charge Weight (lb)	Depth (ft)	Spacing (ft)	Area (ft <sup>2</sup> )	No. of* Charges in Zone	Charge Wt.* in Zone (lb)
A	22	100	8.35	6.82	1440	32	3200
B	20	100	8.35	7.29	3680	68	6800
C	18	50	6.63	5.38	5504	193	9650
D	16	50	6.63	5.78	7584	227	11350
E	14	50	6.63	6.45	10112	244	12200
F	12	50	6.63	7.18	10048	153*	7650*
G	10	50	6.63	8.33	7808	92*	4600*
H	8	50	6.63	9.76	3904	20*	1000*
Totals					50080	1029*	56450*

\*Does not include decoupled charges (see table 3)

The HP I-2A BLEST field design was taken almost directly from early conceptual designs for HP I-3. The simulation time of 18 msec for HP I-2A dictated a periphery bounding a field containing a considerably smaller area. This area was superimposed on the HP I-3 design and, without change in zone boundaries or zone loadings, that portion was cut out to be used as the HP I-2A design. Some inward extension of zones was required because of the smaller HEST area. Figure 11 shows the HP I-2A BLEST configuration superimposed on the preliminary HP I-3 design.

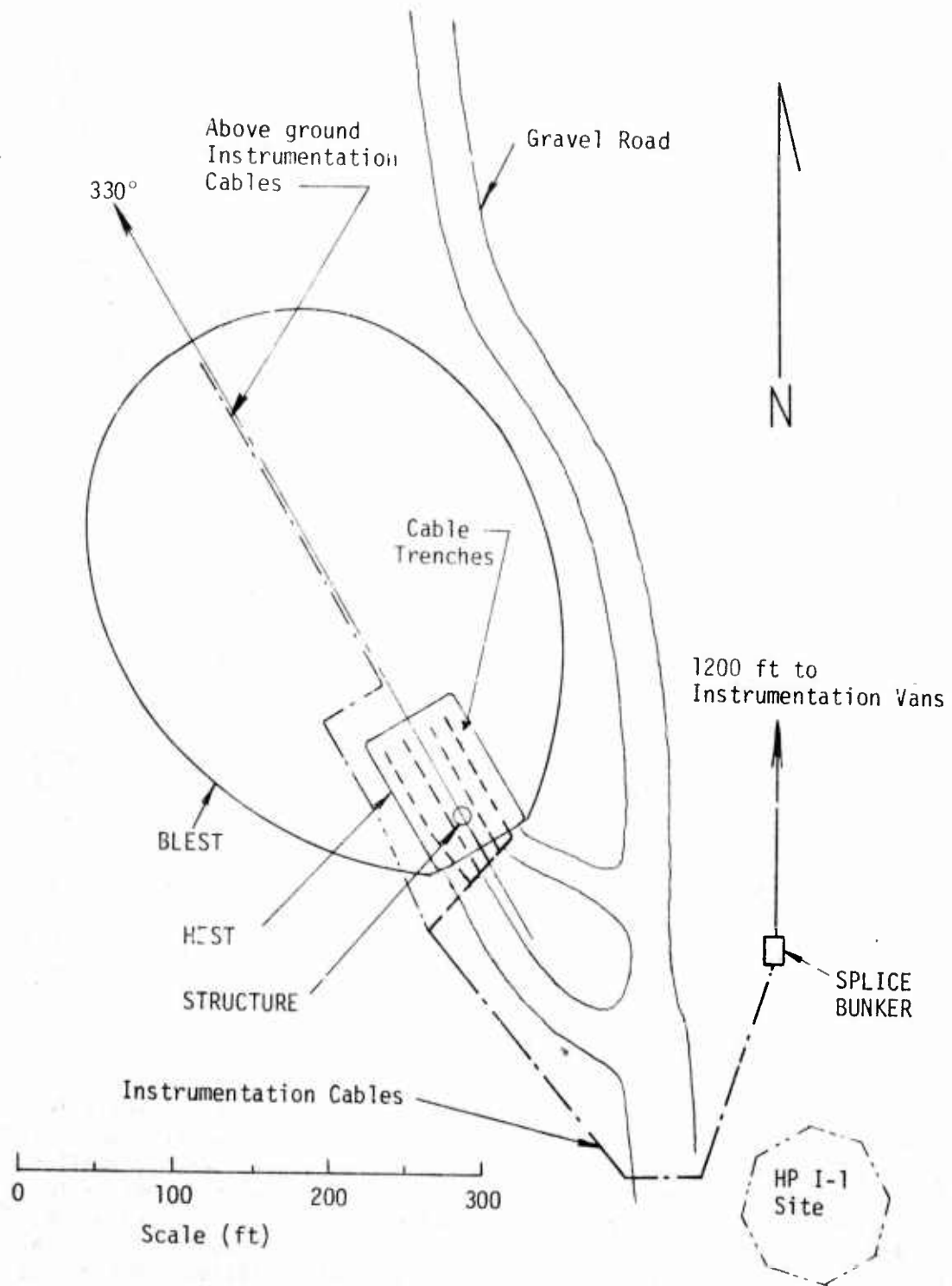

Figure 8. HARD PAN I-2A Site Layout

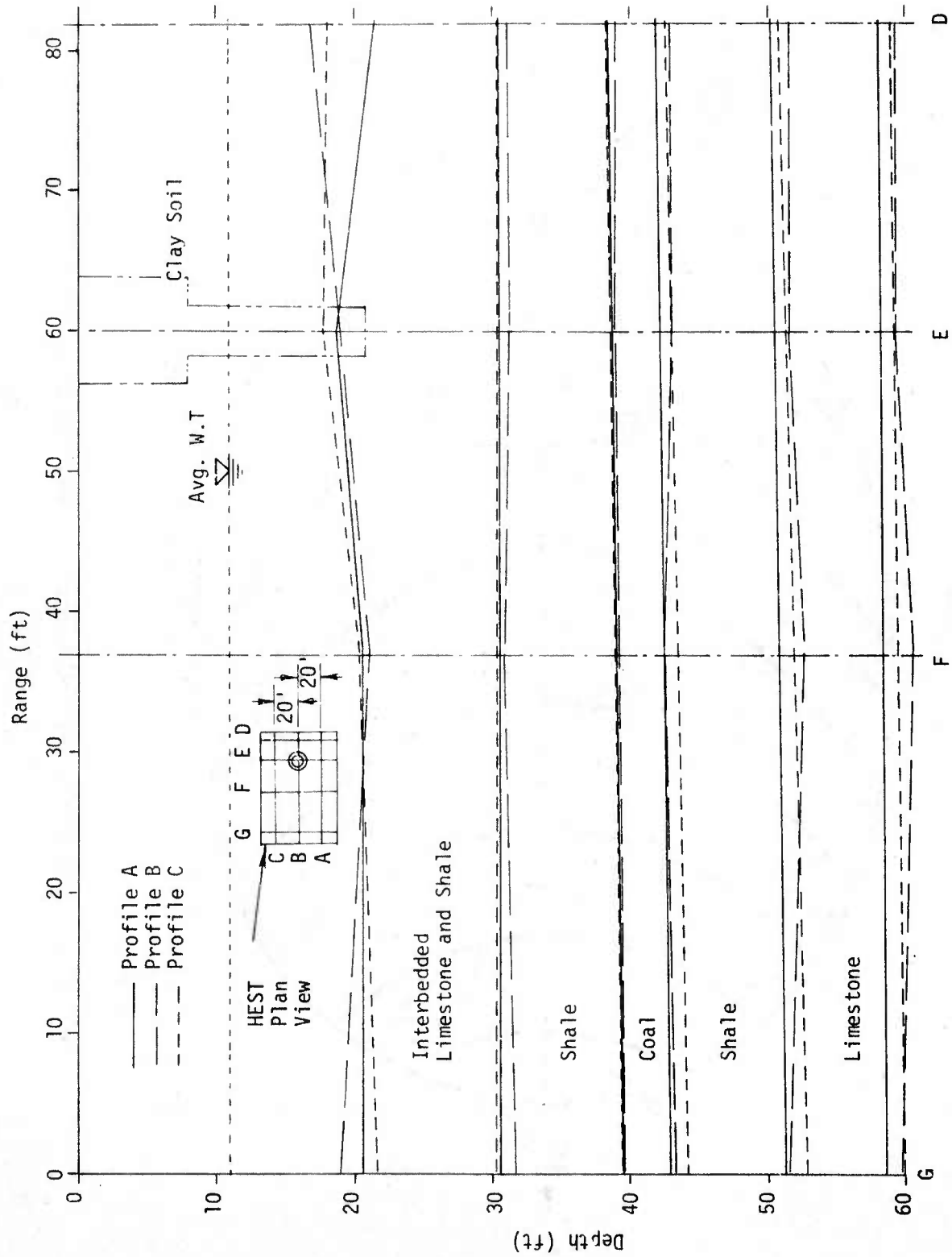

Figure 9. HARD PAN I-2A Geologic Sections

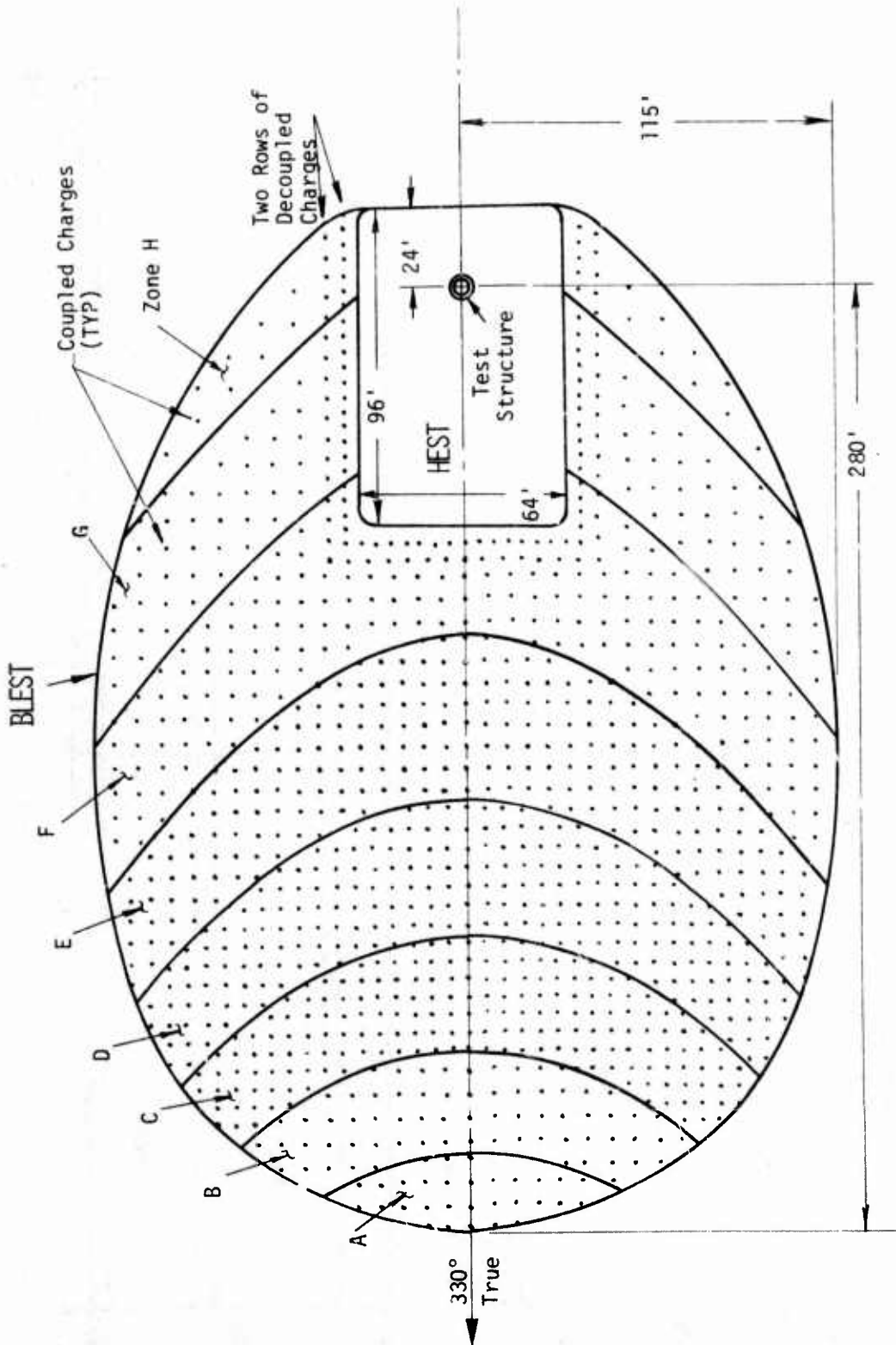
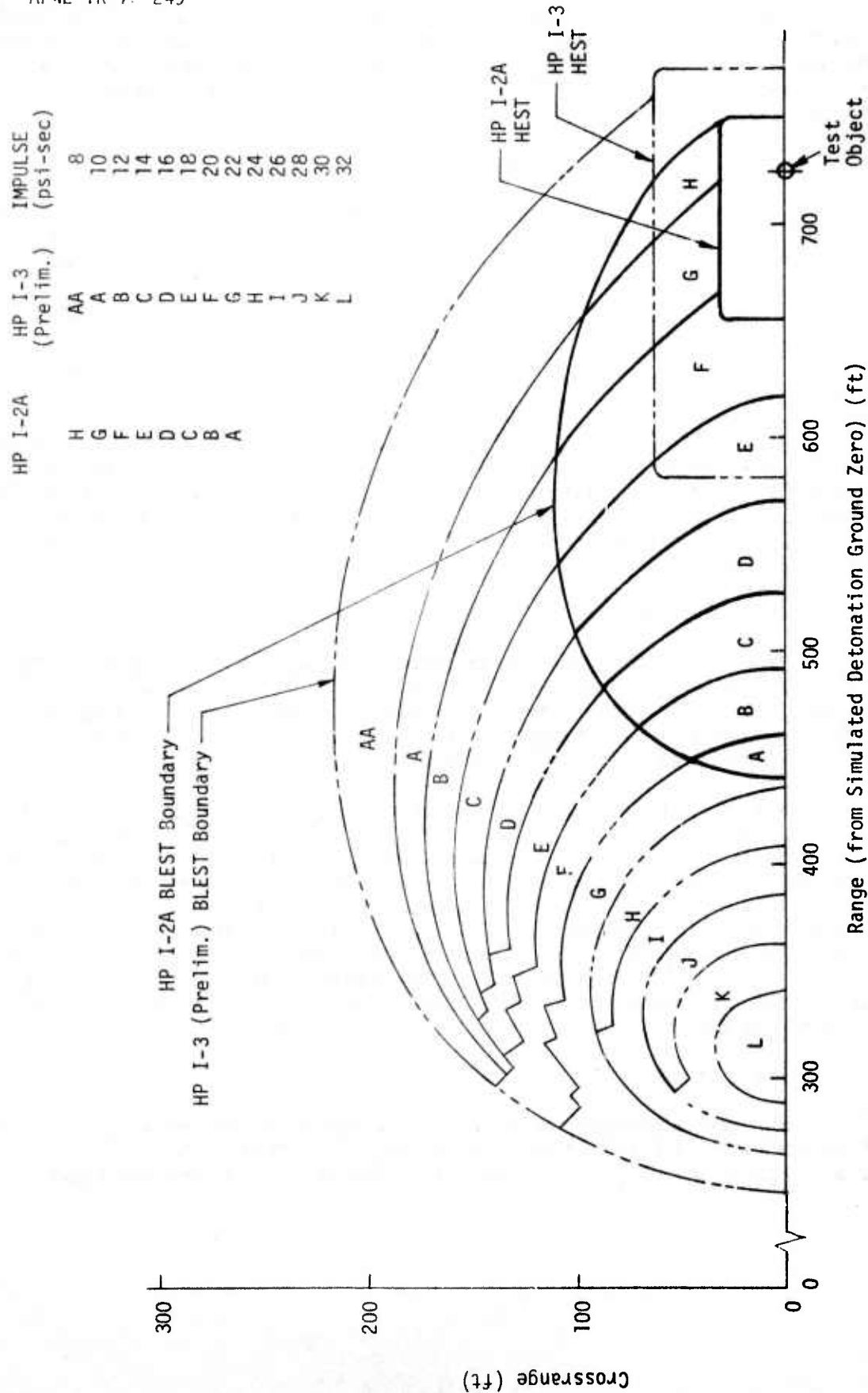

Figure 10. Physical Layout for HARC PAN I-2A



Range (from Simulated Detonation Ground Zero) (ft)

Figure 11. HP I-2A Configuration versus Preliminary HP I-3 Design

In order to provide an impulse related transition between the BLEST and HEST loaded areas, two rows of decoupled explosive holes were placed along three sides of the HEST periphery. Parameters relating to these holes are listed in table 3. Figure 12 shows cross sections of typical coupled and decoupled explosive holes.

Table 3. Decoupled BLEST Holes

Row	Impulse (psi-sec)	Weight (lb)	Depth (ft)	Spacing (ft)	Dist. from HEST Cavity (ft)	No. of Charges in Row	Charge Wt. in Row (lb)
1	18	50	6.63	4.64	4.64	61	3050
2	14	50	6.63	5.97	9.95	47	2350
Totals						108	5400

Detonation of the individual charges in the BLEST field was initiated by a system of connecting lines of detonating cord (60 grain/ft). The system was designed to have redundancy so that if a connecting link of detonating cord to a particular charge failed another path would still exist to provide detonation. Figure 13 shows the trunklines of the detonating cord firing system and figure 14 the typical tie line connections to the individual charges.

#### c. HEST Configuration

For HP I-2A the HEST configuration was rectangular as shown in figure 15. The dimensions of the HEST cavity were 96 ft long, 64 ft wide, and 3 ft high. As in the HP I-1 event, the cavity had a surcharge loading of 500 lb per ft<sup>2</sup> (approximately 4.5 ft depth). The explosive loading was 0.318 lb of PETN per ft<sup>3</sup>, for a total explosive weight of 2.93 tons.

The detonating cord was dispersed throughout the HEST cavity in a 3-dimensional weave similar to that used for the HP I-1 event. Detonation of the cord was initiated at one end by means of detonating cord lines coming in from the BLEST field. The HEST detonation was synchronized with the BLEST detonation to preserve the simulation of an airblast propagating across the earth's surface. The weave angle on the detonating cord was to be such that the blast wave would propagate down the length of the HEST cavity at a velocity of 8500 ft per sec. The HEST portion of the event was designed to produce at the cavity floor an overpressure of 1200 psi with pressure-time decay characteristics matching those of the nuclear burst being simulated.

#### d. Test Structure

The test structure for HP I-2A was constructed by the Civil Engineering Research Facility (CERF) of the University of New Mexico to specifications drawn up by the AFWL. Figure 16 illustrates the geometry of the structure.

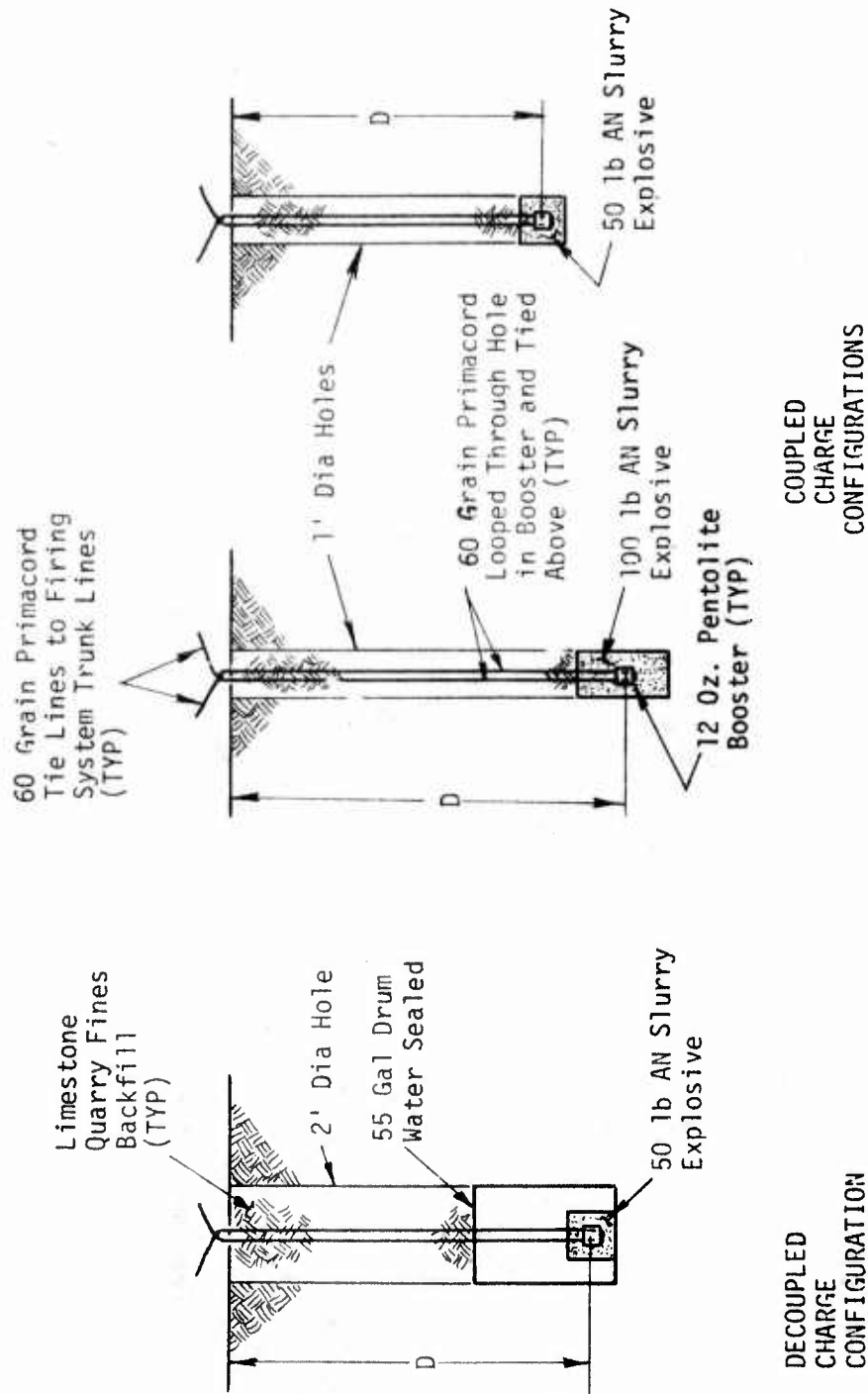

Figure 12. HP I-2A BLEST Charge Emplacement

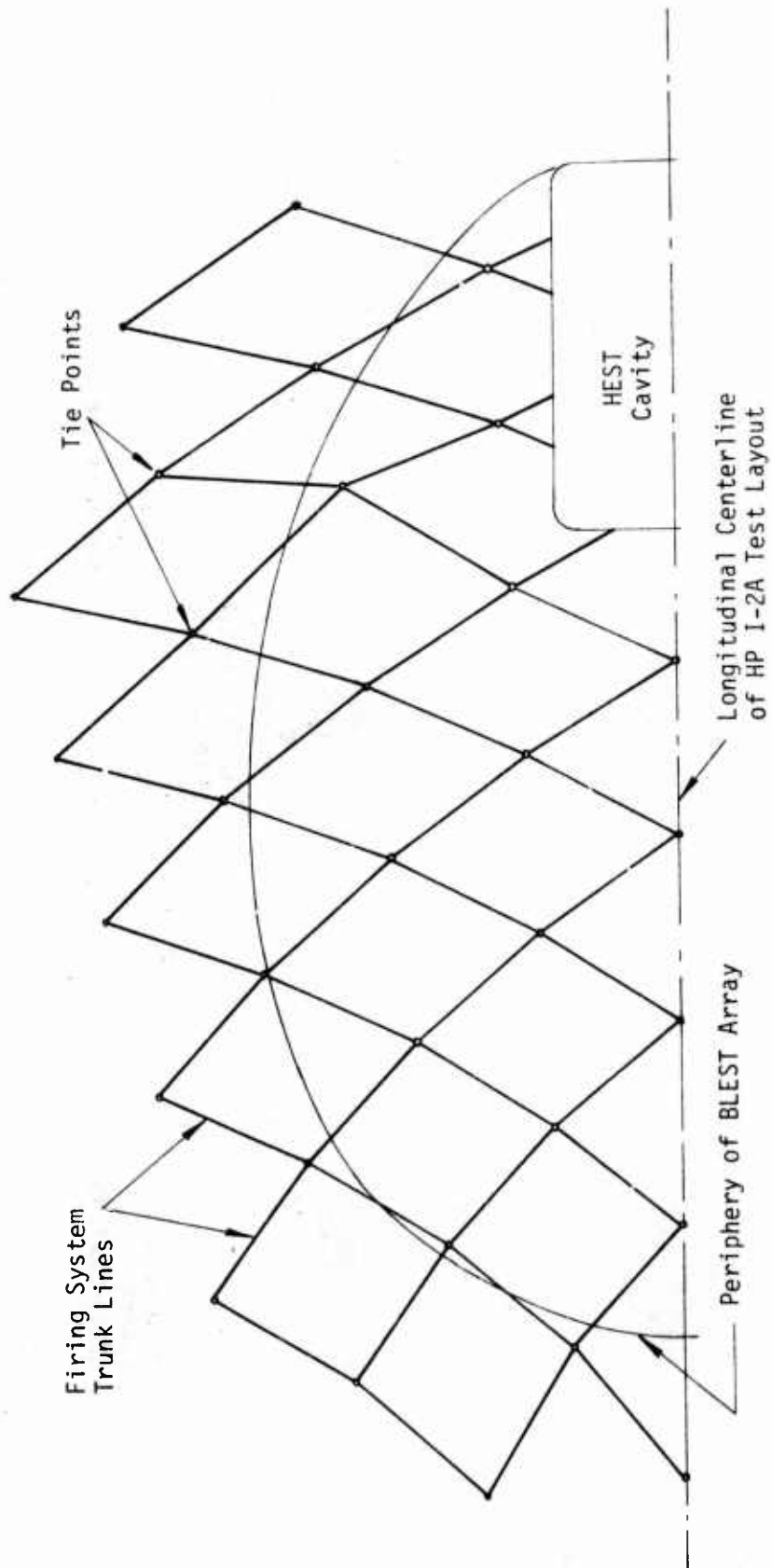

Figure 13. HP I-2A BLEST Array Firing System Trunk Lines

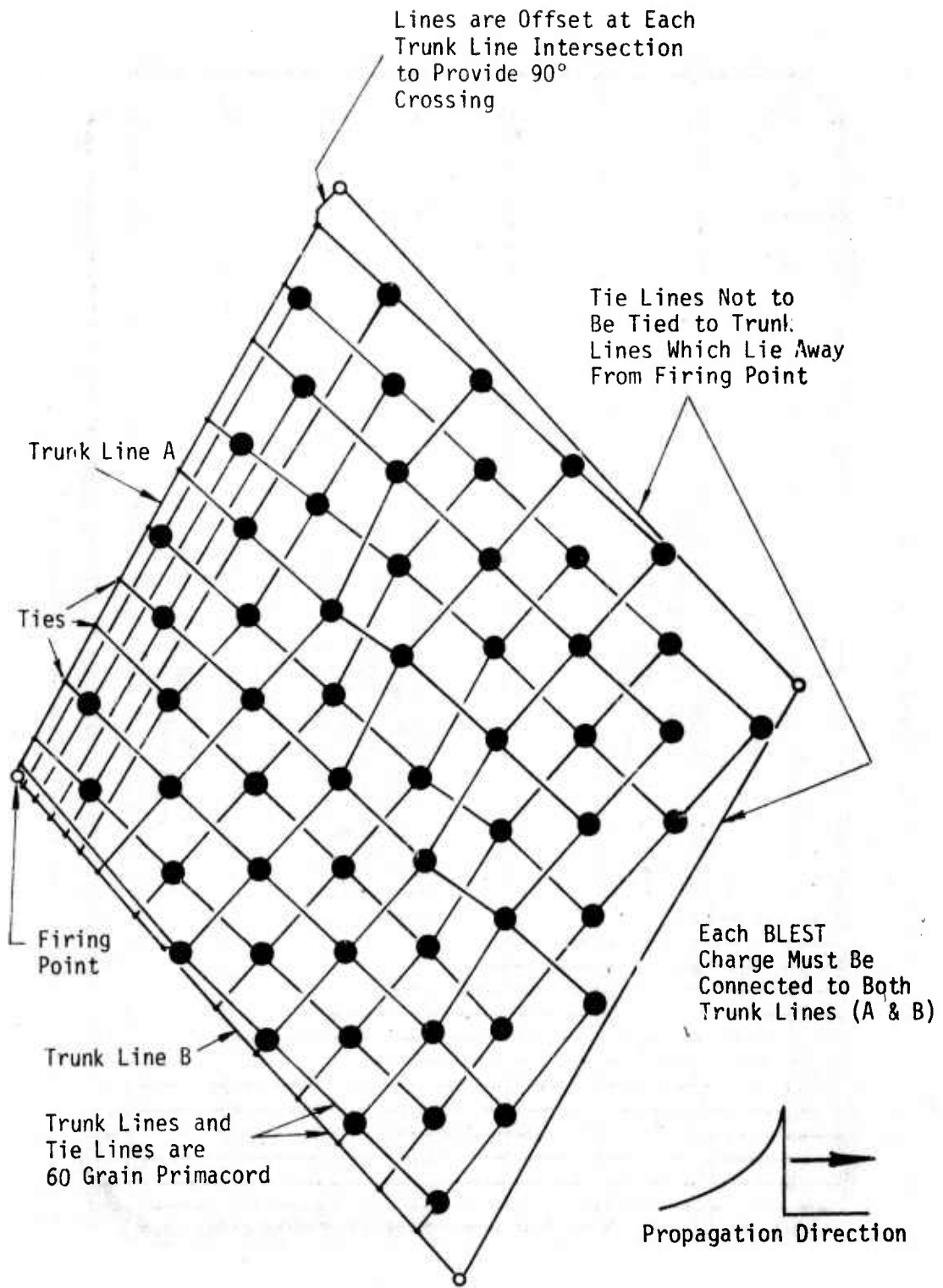
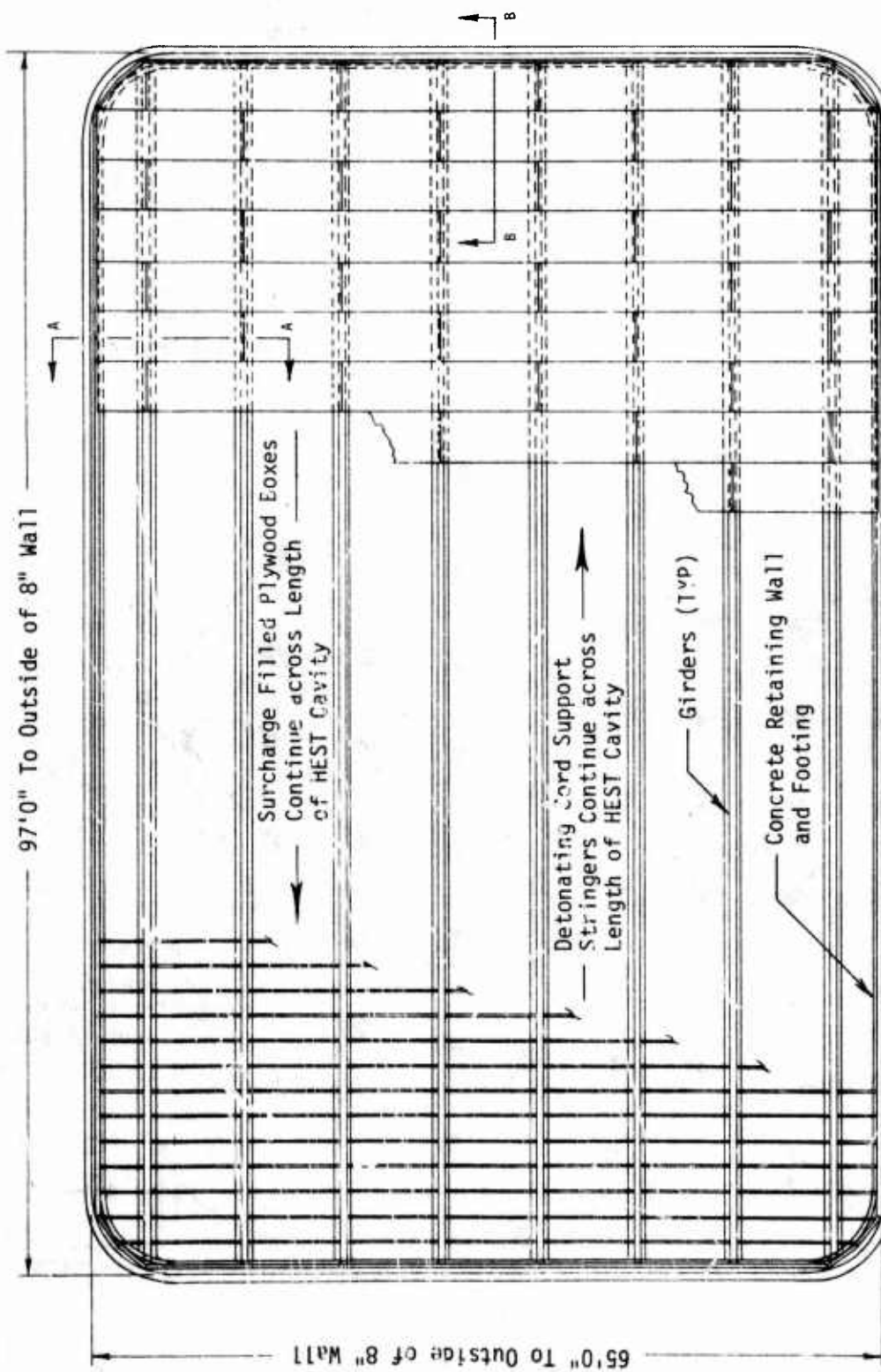

Figure 14. HP I-2A BLEST Firing System Grid



NOTE: See Figure 5 for Approximate Sectional Views

Figure 15. HARD PAK I-2A HEST Construction Details

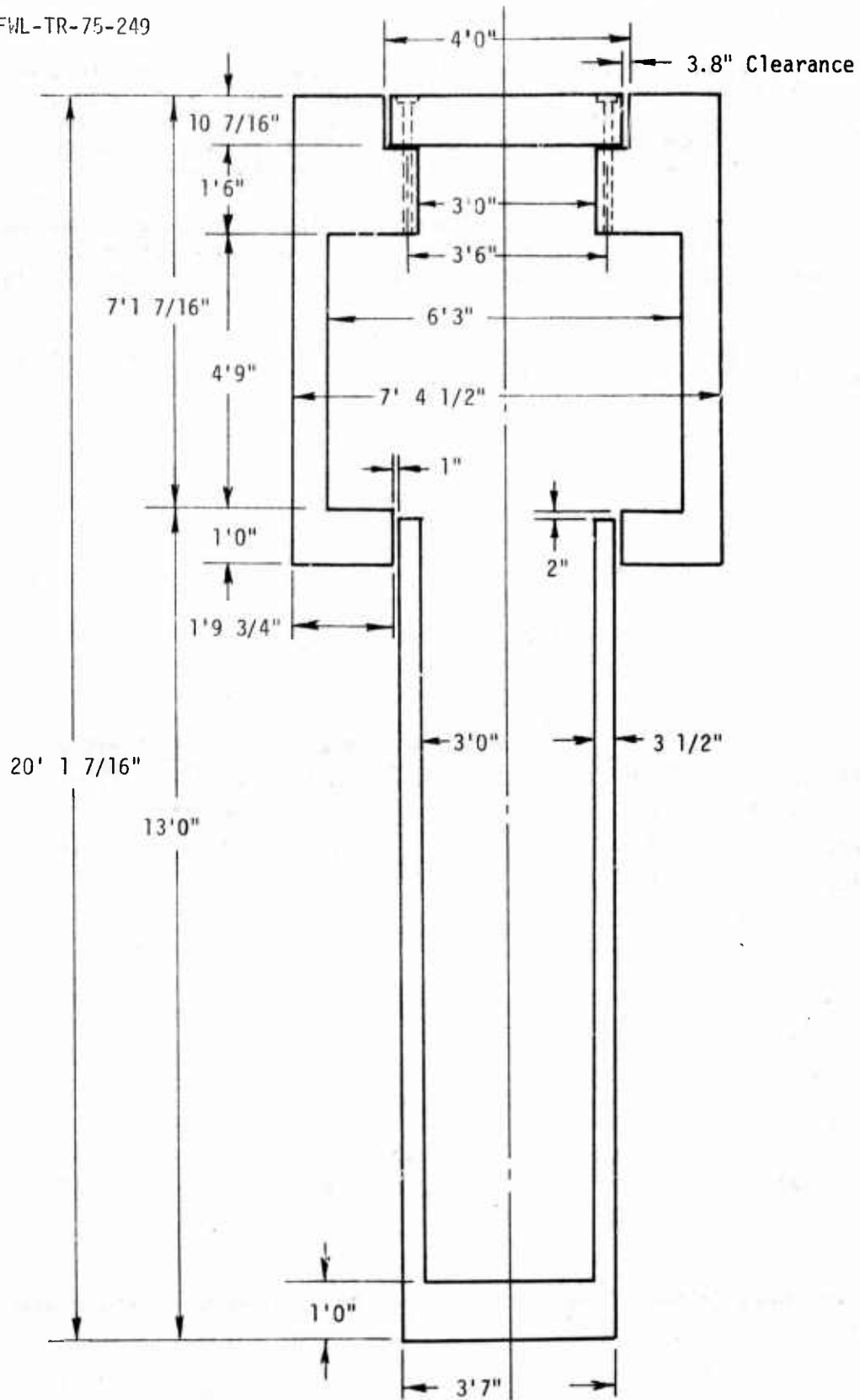

Figure 16. Geometry of HARD PAN I-2A Structure

## e. Instrumentation

Five hundred twenty-six active instrumentation transducers were fielded for the HP I-2A event. These transducers sensed blast pressure, acceleration, velocity, stress and strain at various locations in the structure, its immediate vicinity (near field) and in the outlying free field. Table 4 summarizes the instrumentation for the event.

As in the HP I-1 event a variety of passive gages were employed to measure relative displacements of the structure parts with respect to each other and the surrounding medium, and the deformation of the near field soil.

Details of the HP I-2A instrumentation plan, including specific measurement locations, are contained in Appendix P (Vol. II)

Table 4. HARD PAN I-2A Instrumentation

Measured	Structure	Structure/Medium Interface	Near Field	FREE FIELD		FAR
				HEST	BLEST	
Blast Pressure	6			20(7*)		
Acceleration	32		44	113	16(1)	(9)
Velocity	8			103	12	
Relative Velocity		2				
Relative Displacement	10					
Rebar Strain	78					
Stress-normal		21	30		(1)	
Stress-shear		3				
Sub-totals	134	26	74	236(7)	28(2)	(9)
Total sensors:	498(18)					

\*Note: Numbers in parentheses represent add-on experimental measurements

3. HARD PAN I-2B

a. General

Event HP I-2B, the third major test, was added to the HARD PAN I test series after a review of data from the HP I-2A event. Analysis of those test results pointed to a need for additional empirical testing of the HEST/ BLEST concept before the HP I-3 design could be finalized. As part of the additional testing the calibration tests outlined in Section IV were planned and conducted. In addition, the HP I-2B event was designed to repeat the earlier HP I-2A event, but with modifications dictated by the results of that earlier test and the added calibration shots.

The HP I-2B event configuration differs from that of HP I-2A in several important respects. First, the BLEST field has been redesigned with a consequent reduction in total weight of ammonium nitrate slurry to 16.1 tons from 30.9 tons. Second, the HEST cavity will be square (88 ft x 88 ft) rather than rectangular (96 ft x 64 ft) and will be tapered in depth and charge loading to yield a propagation velocity and peak overpressure varying from one end of the cavity to the other. Third, the test structure will be of a larger size than that used for HP I-2A.

Figure 17 shows the physical layout of the HP I-2B test site. The geologic stratigraphy of the site is shown in figure 18.

b. BLEST Configuration

The event 2-B BLEST and HEST loaded areas will total 74,300 ft<sup>2</sup>, which is thirty-two percent larger than the corresponding areas for the -2A event. Also, the number and sizes of charges will, in general, be reduced. Individual charge sizes will be 25, 50, 100 and 200 lb as contrasted with 50 and 100 lb in the earlier test. There will be a total of 469 individual charges for -2B where there were 1137 for -2A. Figure 17 shows the charge arrangement in the HP I-2B BLEST field. Figure 19 shows an elevation view with details of charge and overburden placements and depth.

The BLEST field for HP I-2B was derived from a redesign of the HP I-3 event. Figure 20 compares the -2B and -3 BLEST fields and indicates that the -2B field design was extracted from the -3 design using a similar "cookie cutter" technique. Table 5 summarizes the charge parameters for each of the HP I-2B BLEST zones.

The BLEST firing system for the -2B event will be quite similar to that for the -2A event (see figures 13 and 14).

c. HEST Configuration

For the HP I-2B event the HEST cavity will be 88 ft x 88 ft in its horizontal dimensions. The vertical depth of the cavity will vary from 2' - 11/16" at the end nearest the BLEST field to 3' - 5 11/16" at the opposite end. The overburden loading will be 500 lb/ft<sup>2</sup> with a nominal depth of 4.5 ft. The detonating cord will be distributed throughout the cavity in a fishnet weave similar to that used for the previous HARD PAN I events.

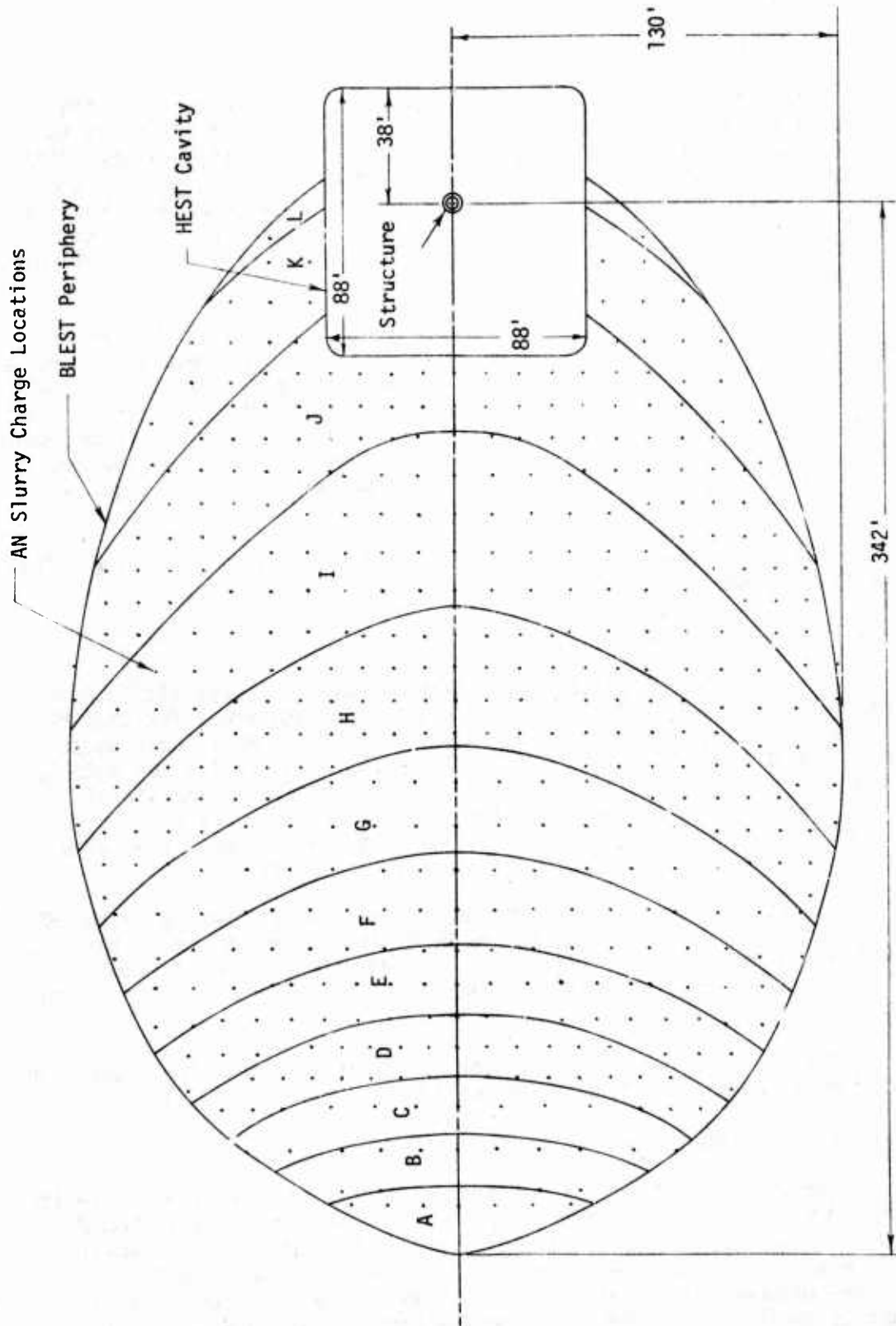

Figure 17. Plan View of HP I-2B Test Site

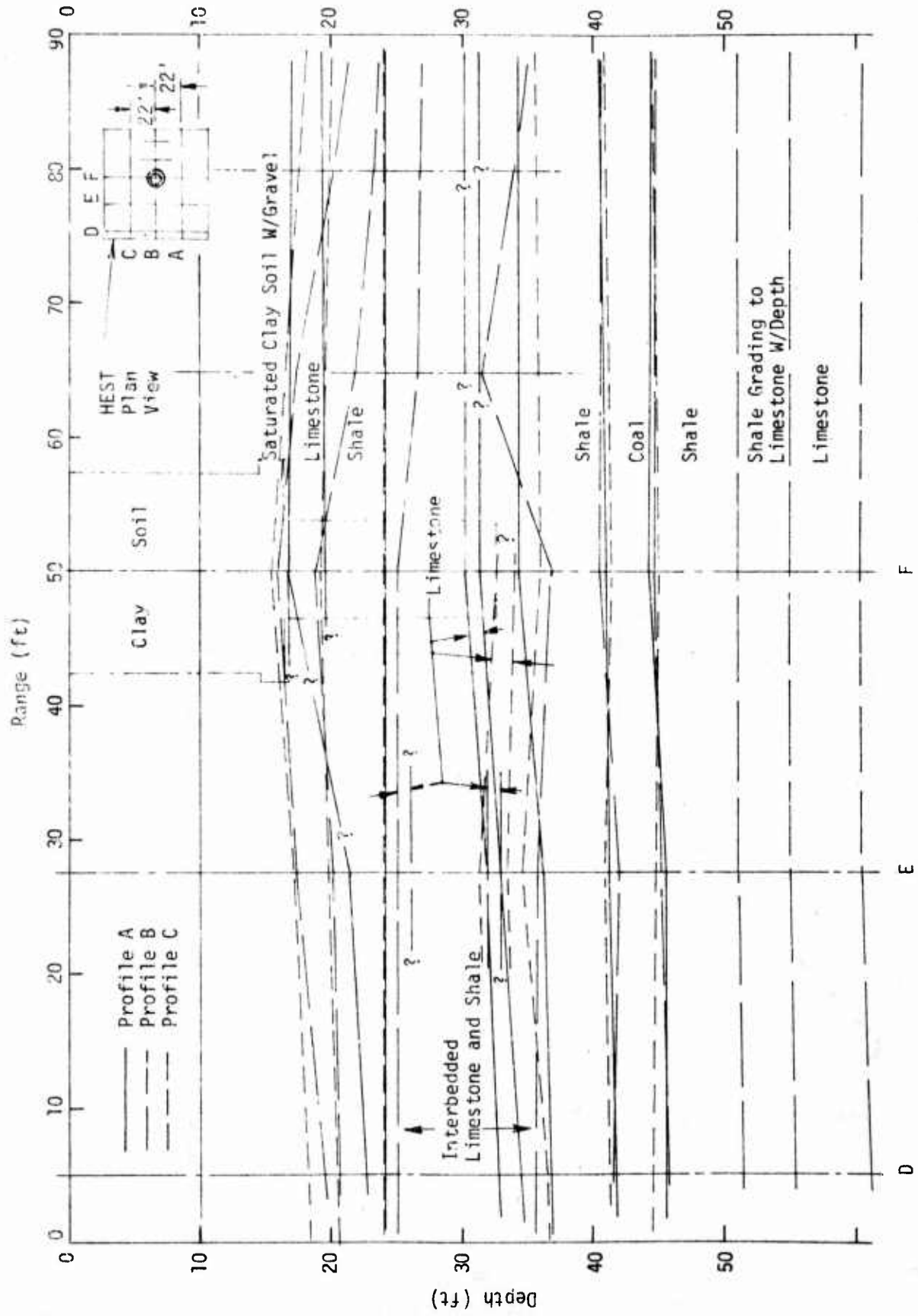

Figure 18. HARD PAN I-2B Geologic Sections

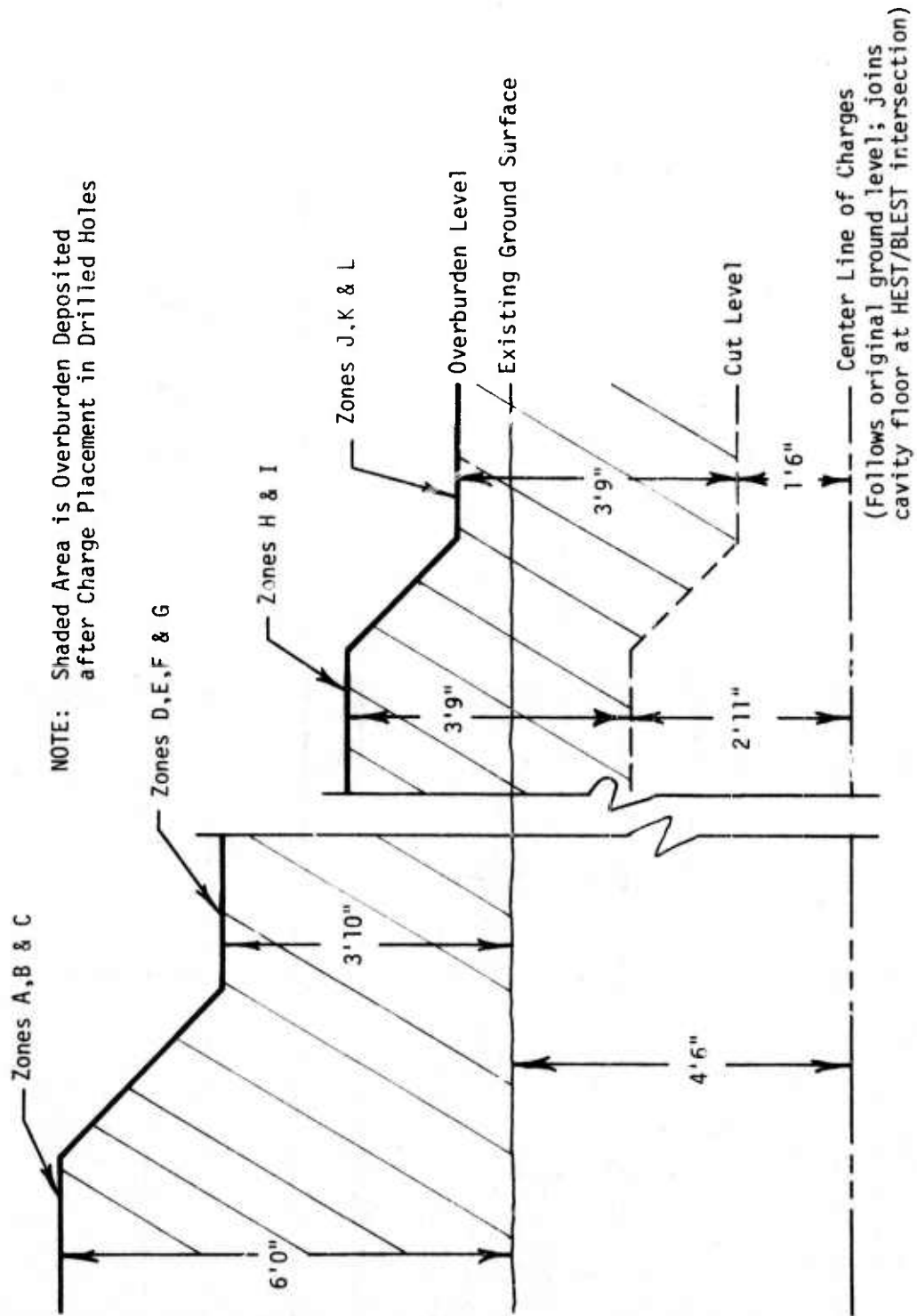

Figure 19. Elevation View - HP I-2B BLEST Field Overburden Configuration

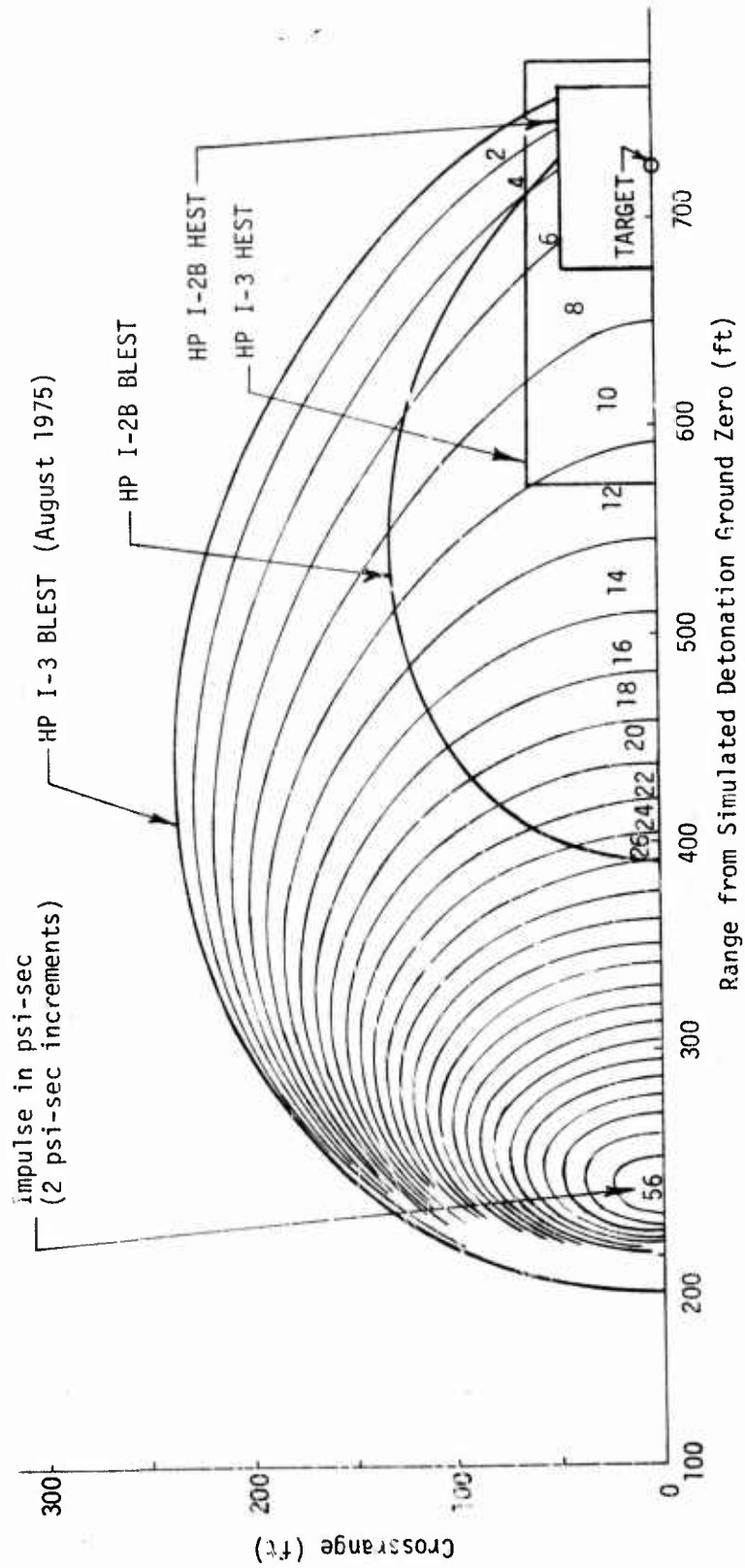

Figure 20. HARD PAN I-2B BLEST as Part of Revised HP I-3 BLEST Design

Table 5. BLEST Charge Parameters - HARD PAN I-2B

<u>Zone</u>	<u>Impulse (psi-sec)</u>	<u>Charge Weight (lb)</u>	<u>Depth* (ft)</u>	<u>Spacing (ft)</u>	<u>Zone Area (ft<sup>2</sup>)</u>	<u>No. of Charges in Zone</u>	<u>Charge Wt. in Zone (lb)</u>
A	26	200	10.50	12.4	975	7	1400
B	24	200	10.50	13.5	1910	11	2200
C	22	200	10.50	14.7	2612	11	2200
D	20	100	8.25	10.2	3548	35	3500
E	18	100	8.25	11.3	4561	34	3400
F	16	100	8.25	12.8	5887	40	4000
G	14	100	8.25	14.5	7680	38	3800
H	12	50	6.67	10.7	10,097	88	4400
I	10	50	6.67	12.8	13,138	81	4050
J	8	25	5.25	10.7	10,994	36	2400
K	6	25	5.25	13.2	4595	26	650
L	4	25	5.25	18.9	585	2	50
Totals					66,582	469	32050

\*Depth to charge center from top of overburden (figure 20)

The density of explosive loading will, however, vary from 0.390 lb/ft<sup>3</sup> at the initiating end to 0.278 lb/ft<sup>3</sup> at the final end for a total explosive weight of 3.39 tons of PETN. This loading, together with the tapered cavity and the overburden loading will yield overpressures varying from 1470 psi to 1050 psi across the length of the HEST. Propagation velocities are calculated to vary from 9350 fps to 8000 fps in that distance.

d. Test Structure

The test structure for HP I-2B is axisymmetric and in two parts as shown in figure 21. The lower structure was built to AFWL specifications by CERF and the upper structure was cast in place according to AFWL specifications by the Bob Rutherford Construction Company (BRCC).

e. Instrumentation

Approximately six hundred active instrumentation channels will be fielded for the HP I-2B event. The associated transducers will sense blast pressure, acceleration, velocity, stress and strain at various locations in the structure, its immediate vicinity (near field) and in the outlying free field.

Details of the HP I-2B instrumentation plan, including specific measurement locations, are contained in Appendix P (Vol. III).

4. HARD PAN I-3

a. General Test Configuration

The final design details for the HP I-3 event will be dependent on the results of all preliminary testing. The environment to be simulated is that due to the detonation of a 125 kT device at 210 ft HOB and 725 ft range. The simulation time for the event is to be 30 msec. Figure 22 shows the geologic stratigraphy of the proposed test site.

b. BLEST Configuration

The area encompassed by the HP I-3 BLEST field boundary will be approximately 211,000 ft<sup>2</sup>, and includes a large portion of the HEST area. For convenience, the BLEST field is divided into a number of distinct zones in which charge size, spacing, and depth of charge burial are uniform. These zones are shown in figure 20 which illustrates a potential HP I-3 BLEST configuration. Each such zone then yields a uniform impulse loading. These zones are incremented in 2 psi-sec steps and range from 2 psi-sec at the low end (periphery) to 56 psi-sec at the high end.

The total weight of AN slurry to be used for the BLEST field is approximately 95 tons. The individual charges will vary in size from 25 lb to 1000 lb and will be built up of 25 and 50 lb bags of slurry. The final BLEST design for HP I-3 is not available at the time of this writing.

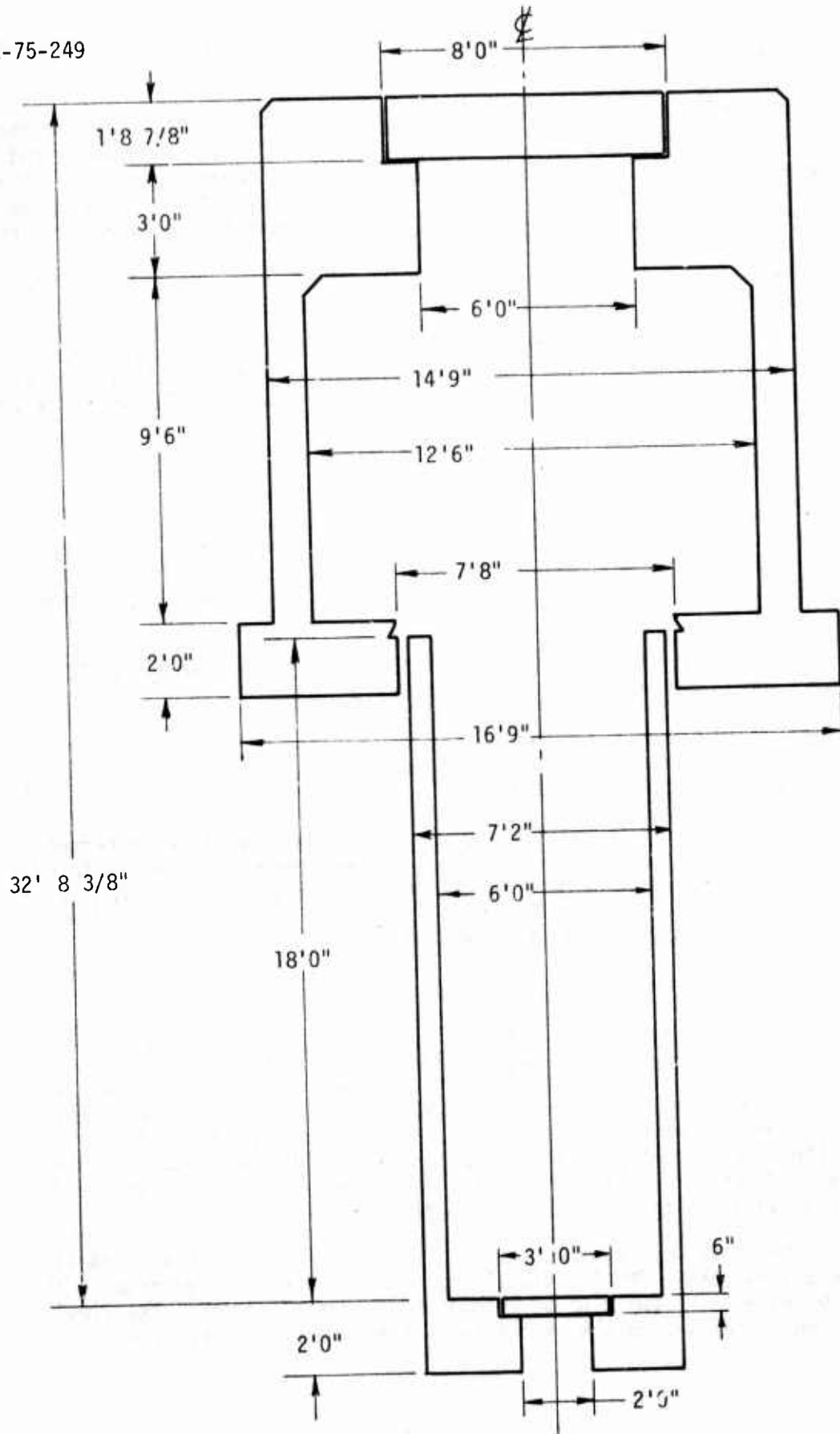

Figure 21. Geometry of HARD PAN I-2B Structure

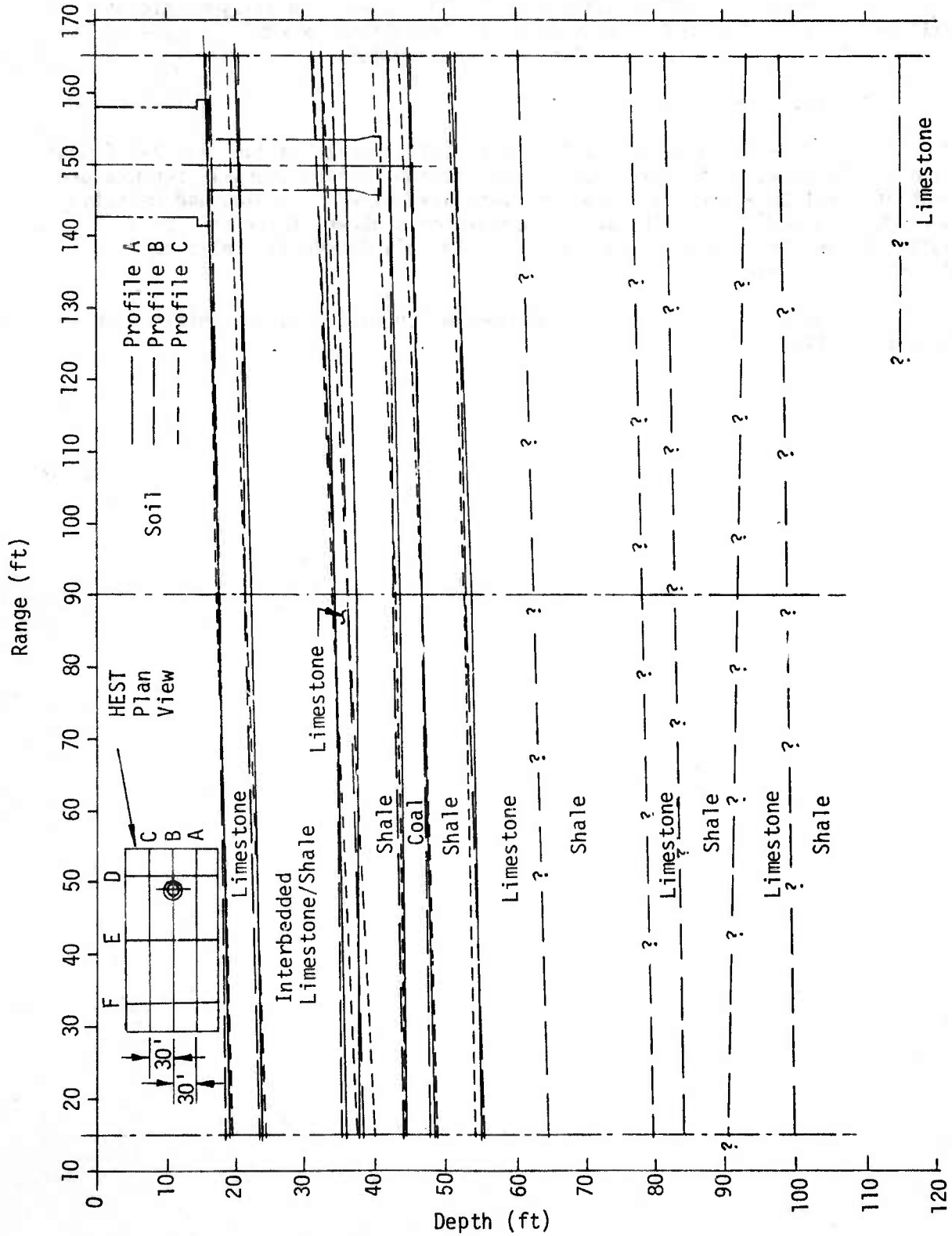

Figure 22. HARD PAN I-3 Geologic Sections (HEST Area)

c. Structure

The test model or structure for HP I-3 will be axisymmetric and will be built at the test site to AFWL specifications by BRCC. Figure 23 presents the major design dimensions of the structure.

d. Instrumentation

HP I-3 will be the most heavily instrumented of the HARD PAN I test events. There will be approximately 700 instrumentation channels for measurement of blast pressure, acceleration, velocity, stress, strain, and relative motions. In addition to the active measurements above, there will be a number of devices installed to give net total displacements, relative displacements, etc.

Details of the HP I-3 Instrumentation plan will be contained in Appendix O (Vol. III).

AFWL-TR-75-249

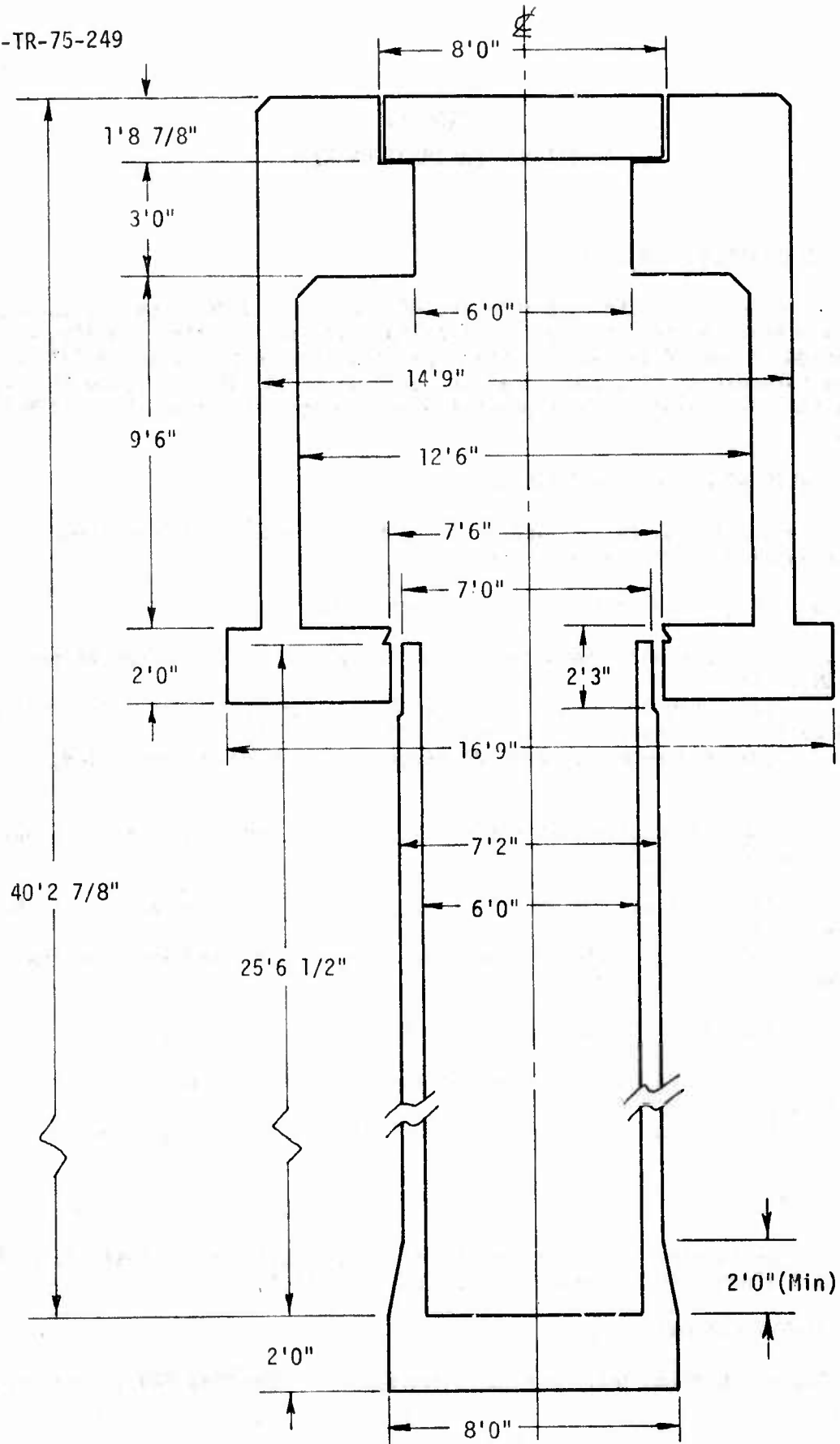

Figure 23. Geometry of HARD PAN I-3 Structure  
45

SECTION IV  
ADDITIONAL CALIBRATION EVENTS

1. REQUIREMENT FOR TESTS

As a result of the data from the HP I-2A event a decision was made by SAMSO and AFWL to conduct a series of calibration tests before finalizing the design of the HP I-3 event. Principal concerns relate to the BLEST area loading parameters. The additional calibration tests outlined below should remove the uncertainties which presently exist with respect to the HEST/BLEST design.

2. CALIBRATION TEST OBJECTIVES

The additional calibration tests to be performed fall into three categories with objectives as listed:

a. Single (Charge) Calibration Tests (SCAL)

- (1) Evaluate the motions from individual BLEST charges at the HARD PAN I site.
- (2) Develop the basic empirical data for developing a prediction procedure for the stresses which result from the BLEST.
- (3) Evaluate the relative effects of coupled and decoupled charges.

b. (BLEST) Impulse Calibration Tests (ICAL) and Supplementary Impulse Calibration Tests (SICAL)

- (1) Evaluate the empirical impulse prediction procedures at the HARD PAN I site.
- (2) Evaluate the impulse simulation for selected areas of the HARD PAN I-3 impulse design.

c. HEST/BLEST Evaluation Tests (HBL)

- (1) Evaluate the stress and motion attenuation characteristics of small BLEST arrays.
- (2) Compare a BLEST and HEST simulation for the same nuclear environment.

3. TEST SCHEDULE

The performance schedule for the HARD PAN I Calibration Tests is given in Table 6 along with parameters for each of the tests.

4. TEST LOCATIONS

The calibration tests are to be conducted in the HARD PAN I test area

Table 6. HARD PAN I Calibration tests

Test Event	Charge Configuration	Total Charge (lb)	Date
SCAL I	Single Charge (Coupled)	50 lb AN slurry	3/11/75
SCAL II	Single Charge (Decoupled)	50 lb AN slurry	3/21/75
SCAL III	Single Charge (Coupled)	50 lb AN slurry	3/28/75
SCAL IV	Single Charge (Decoupled)	50 lb AN slurry	4/4/75
ICAL I	3 x 3 BLEST	450 lb AN slurry	5/15/75
ICAL II	3 x 3 BLEST	450 lb AN slurry	4/24/75
ICAL III	3 x 3 BLEST	450 lb AN slurry	5/1/75
ICAL IV	3 x 3 BLEST	900 lb AN slurry	5/8/75
ICAL V (SICAL I)	Single Charge (Coupled)	50 lb AN slurry	6/27/75
ICAL VI (SICAL II)	3 x 5 BLEST	750 lb AN slurry	6/28/75
HBL I	4 x 4 BLEST	.4 tons AN slurry	6/10/75
HBL 2	7 x 7 BLEST	2.5 tons AN slurry	6/17/75
HBL 3	48' x 48' HEST	1.3 tons PETN	5/28/75

at locations having geologies comparing favorably with those of certain portions of the HP I-3 test bed. Figure 24 shows the locations at which the various added test events are presently planned. These are shown in relation to the sites of the completed HP I-1 and HP I-2A events and the planned HP I-2B and HP I-3 events.

## 5. TEST DESCRIPTIONS

### a. SCAL and SICAL I

The SCAL series and SICAL I are composed of single shot tests. In each of them a 50 lb charge of ammonium nitrate slurry will be center detonated. Two of the SCAL shots and the SICAL I shot will be coupled to the ground; and two of the SCAL shots will be decoupled by placing the 50 lb bag of slurry in the bottom of a 55 gallon steel drum. In the coupled configuration the charge will be placed at a depth of 3 feet below the existing ground surface; and in the decoupled configuration the center of the drum will be placed at a depth of 3 feet below the existing surface. The explosive holes will be backfilled and overburden will be laid on the surface to a total depth as listed below. To insure uniformity in the overburden, it will be laid in several courses and compacted between each course. The radius to which the overburden will be deposited will be such as to insure that the resulting crater lies within the overburden. Figure 25 shows the physical configuration in which the tests will be conducted. Velocity, acceleration, and soil stress gages will be used to record the test results. Photographic coverage will also be provided.

<u>Event</u>	<u>Configuration</u>	<u>Depth</u>	<u>Charge</u>
SCAL I, II, and SICAL I	Single Charge (Coupled)	6.75 feet	50 lb
SCAL II & IV	Single Charge (Decoupled)	6.75 feet	50 lb

### b. ICAL and SICAL II

The four ICAL shots consist of 3 x 3 arrays of buried AN slurry charges according to the schedule below. The SICAL II shot will be a 3 x 5 array.

	Spacing (ft)	Depth (ft)	Charge Size (lb)	Impulse (psi-sec)
ICAL I	5	6.6	50	19.2
ICAL II	10	6.6	50	7.8
ICAL III	7	6.6	50	12.5
ICAL IV	7	8.4	100	21.4
SICAL II	15	6.75	50	8.4

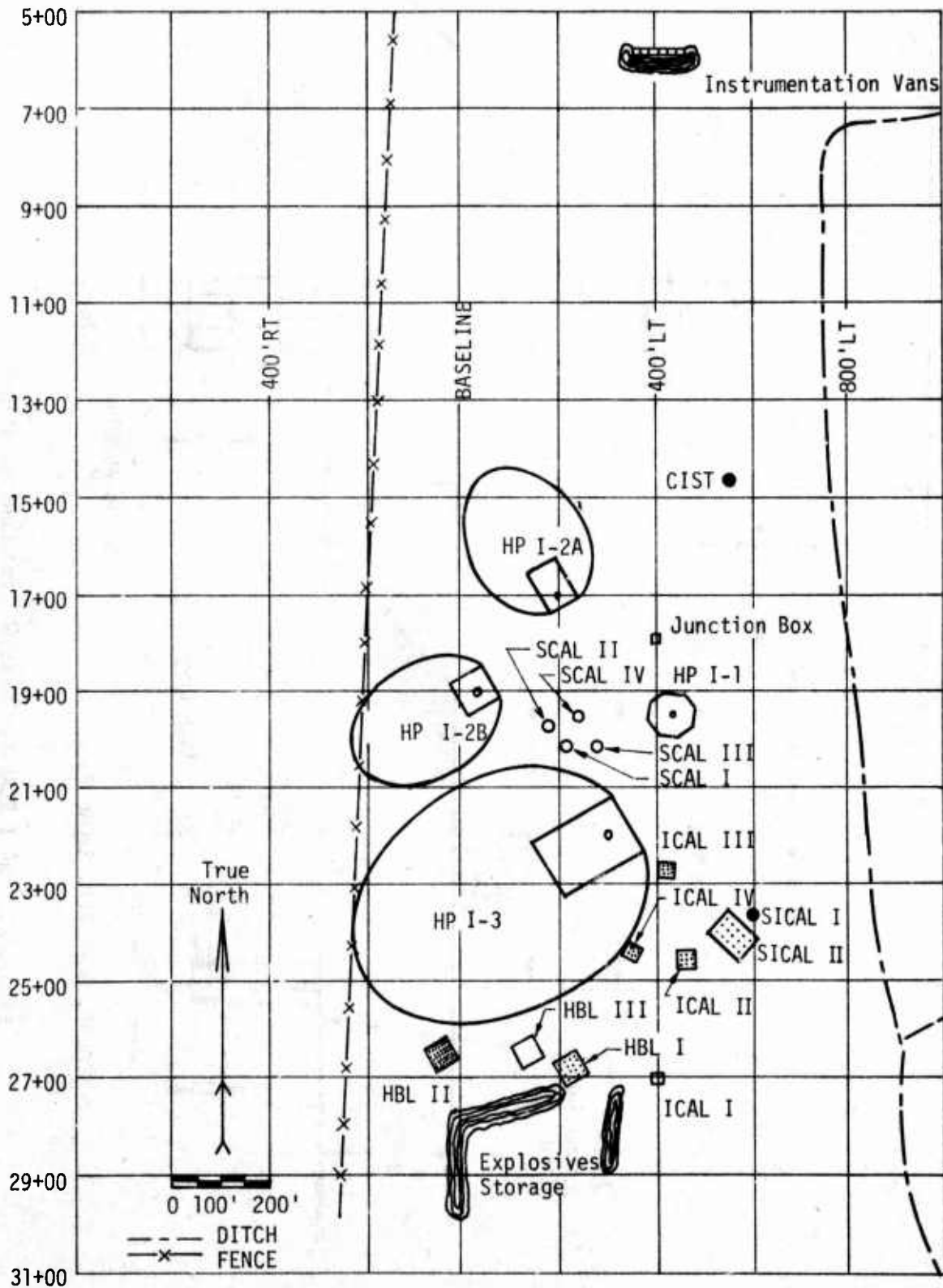

Figure 24. Location of Calibration Events

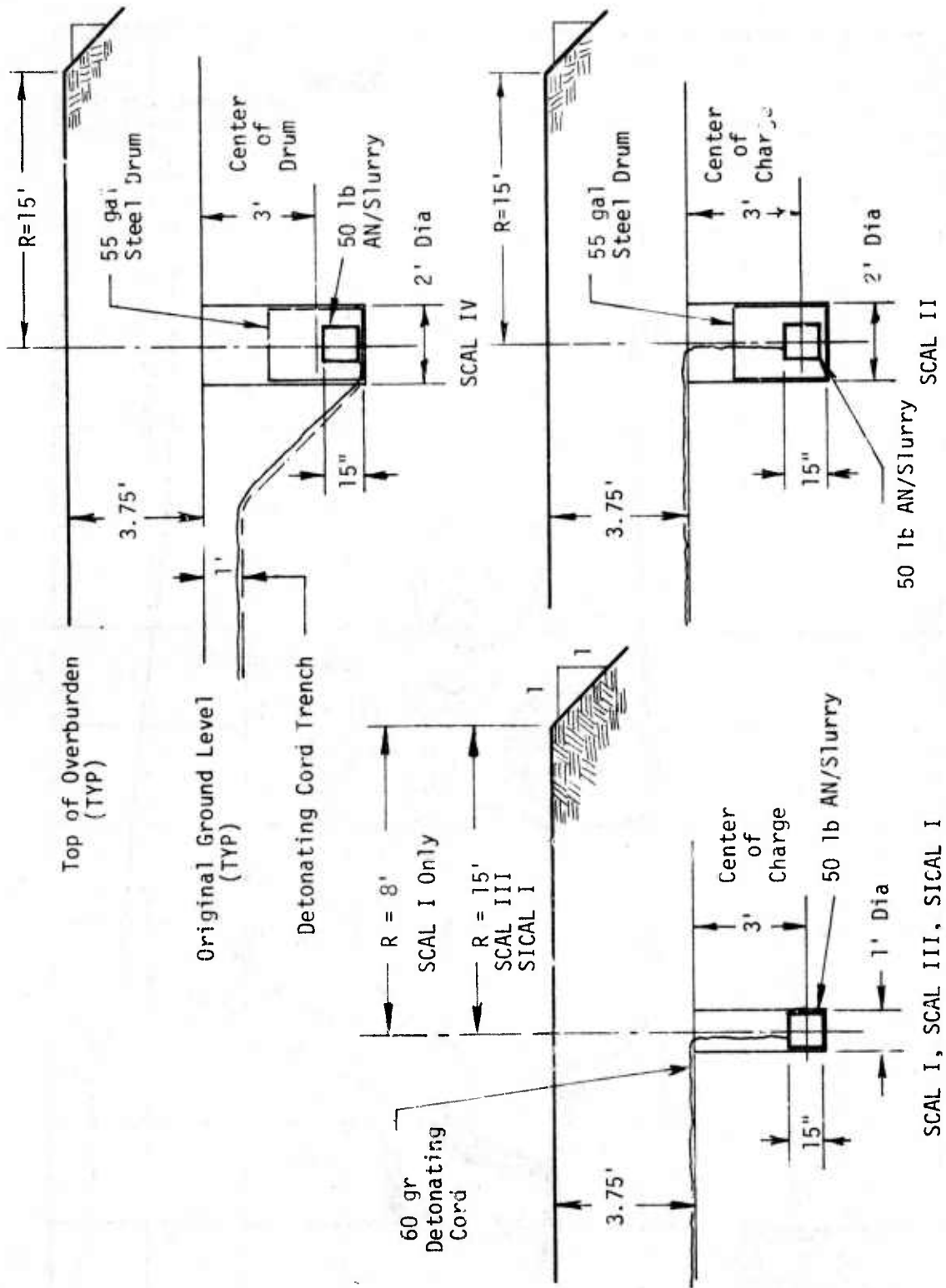

Figure 25. HP I SCAL Calibration Test Configurations

As in the SCAL series the charges will be placed in holes and backfilled. The array will then be covered with overburden approximately 3' deep to obtain the desired depth of charge burial as listed above. Charge sizes, spacings, and depths of burial were selected to yield the average impulses listed above. Instrumentation and photographic coverage will be provided to meet the test objectives stated above.

c. HBL

The HBL series of tests is to determine, among other things, the equivalency of HEST and BLEST arrays to produce a planned shock environment. Two small BLEST arrays (4 x 4 and 7 x 7) and one HEST array are to be detonated. Particulars on the BLEST arrays are

	Configuration	Spacing (ft)	Depth (ft)	Charge Size (lb)	Total Charge wt. (lb)
HBL 1	4 x 4	12	6.6	50	800
HBL 2	7 x 7	7	8.4	100	4900

Again, the depth of burial listed represents the depth measured from the top of the overburden which will be approximately 3 ft deep. The average impulse for HBL 1 is calculated to be 10 psi-sec, and that for HBL 2, 24 psi-sec.

The HBL 3 test will be of a 48' x 48' HEST array designed to yield an overpressure peak of 2750 psi. Cavity depth will be 1.5 ft and overburden depth will be approximately 4.5 ft. The explosive charge density will be .729 lb/ft<sup>3</sup> for a total PETN charge of 2515 lb. The detonating cord weave will be designed to yield a horizontal propagation velocity of 12,200 fps across the 48 ft length of the cavity.

d. Instrumentation

Details of the SCAL, ICAL, and HBL instrumentation plans, including specific locations at which measurements will be made, are contained in Appendix P, Parts 3, 4, and 5, Vol III.

SECTION V  
PROGRAM MANAGEMENT

1. TEST DIRECTION

Test direction shall be the responsibility of the Civil Engineering Research Division, Facility Survivability Branch (DEV) of the AFWL. The authority necessary to perform the fielding of this experiment is delegated to the Test Conductor. Minor field modifications shall be coordinated with the Test Conductor, while all major changes shall be approved by the Test Director. External support requirements shall be approved by or requested through the Test Director. Participating agencies shall coordinate their activities through the Test Director and shall be responsible to the Test Conductor during fielding of their experiments. Requests for AFWL field support for these agencies shall be coordinated with the Test Conductor before approval.

2. ORGANIZATION

Figure 26 displays in chart form the SAMS0/AFWL organization set up to implement the HARD Pan I test series.

3. TASK/SUBTASK RESPONSIBILITIES

The following list identifies the tasks and subtasks necessary for the successful completion of the HARD PAN I tests and indicates the AFWL branches responsible for the operations specified or for furnishing inputs.

<u>TASK/SUBTASK</u>	<u>DESCRIPTION</u>	<u>BRANCH (OPR/INPUTS)</u>
1.0	Test Direction	DEV
1.1	Schedules	DEV/DEV
2.0	Test Plan	DEV
2.1	Safety Plan	DEX/DEV
2.1.1	Van Protection/Grounding	DEX/SE
2.2	Security Plan	DEX
2.3	Communications	DEX
2.4	SAMS0 Management Agreement	DEV
2.5	Countdown Sequence/Hold Procedures	DEX/DEV
2.6	Maps	DEV
2.7	Post-Test Operations Plan	DEX/DEV
2.8	Site Restoration-Rollup	DEX/DEV
2.9	Instrumentation Plan	DEX
2.9.1	Measurement Requirements List	DEV
2.9.2	Measurement List and Gate Selection	DEX
2.9.3	Calibrations	DEX

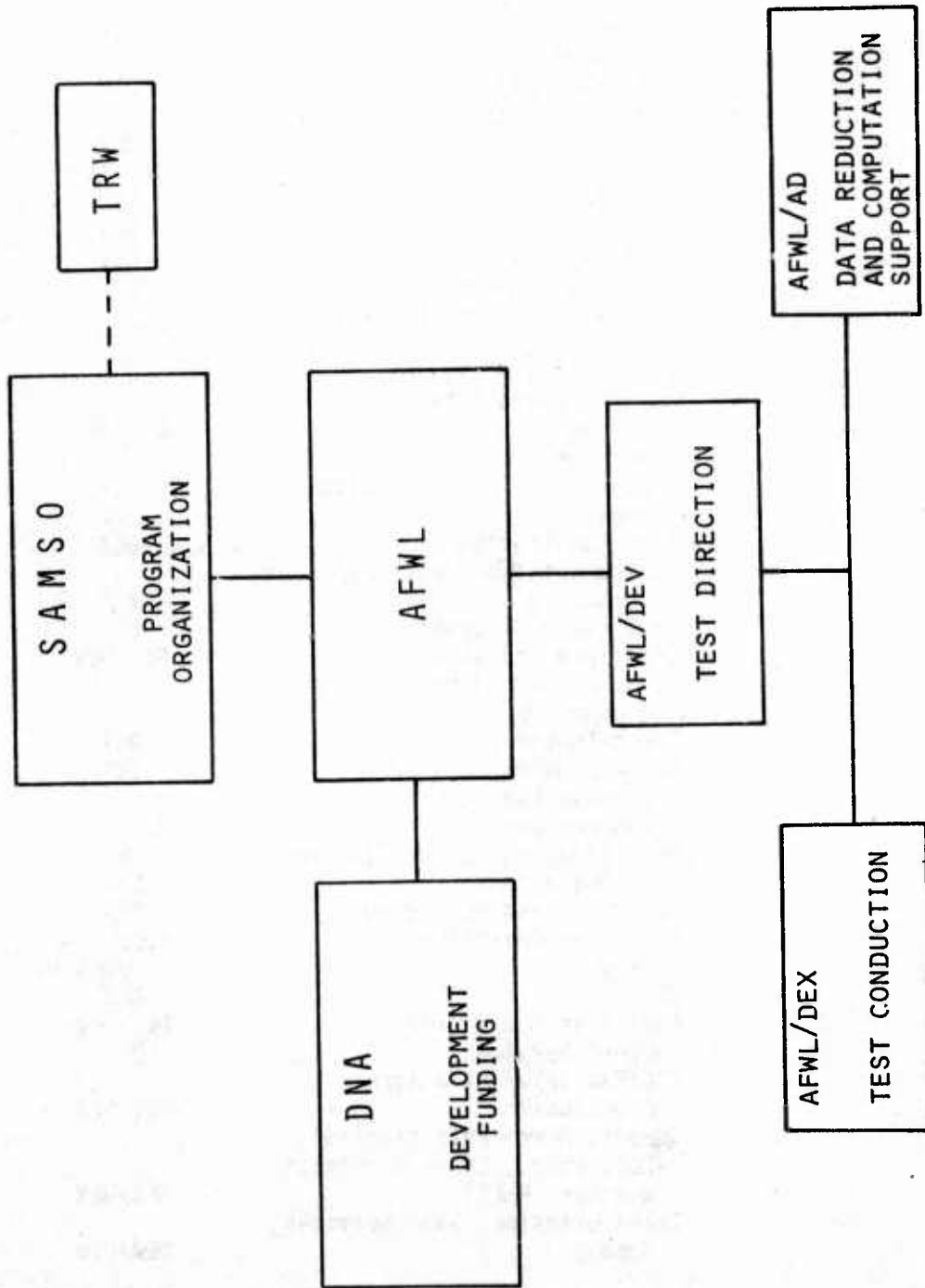

Figure 26. HARD PAN I Program Responsibilities

<u>TASK/SUBTASK</u>	<u>DESCRIPTION</u>	<u>BRANCH (OPR/INPUTS)</u>
2.9.4	Canisters/Package Techniques	DEX
2.9.5	Placement Procedures	DEX
2.9.6	Grout Mix Design	DEV
2.9.7	Test Analysis Plan	DEV
2.9.8	Data Reduction Plan	DEV/DEX
2.9.9	Predictions (Free Field, Structures)	DEV
2.9.10	Recording (Equipment, Procedures)	DEX
3.0	Site Activation and Operations	DEV
3.1	Site Selection	DEV/DEX
3.2	Soil Tests	DEV
3.3	Geologic Tests	DEV
3.4	Environmental Assessment	DEV
3.5	Site Development	DEX
3.5.1	Explosive Design (Cavity, Dispersal)	DEV
3.5.2	OP Facility Design	DEV
3.5.3	Structure and Site Design	DEV/DEX
3.5.4	Government Furnished Material (incl explosives)	DEX
3.5.5	Survey	DEV
3.5.6	Site Construction	DEX
3.5.7	Instrumentation Drilling/Trenching	DEX/DEV
3.5.8	Free Field Placement	DEX
3.5.9	Structure Installation	DEX/DEV
3.5.10	Medium Interaction Gage Placement	DEX
3.5.11	Grout/Concrete	DEX
3.5.12	Cable Hookups	DEX
3.5.13	Explosive Placement and Connections	EOD-DEX/SE
3.5.14	Participating Agency Closures	DEX
3.6	Test Operations	DEX
3.6.1	Countdown and Recording	DEX
3.6.2	Explosive Operations	EOD/SE/WE
3.6.3	Safety	SE/DEX/WE
3.6.4	QC	DEX
3.6.5	Post-Test Operations	DEX/DEV
4.0	Support Services	DEV
4.1	FCC/FAA/Interested Agency Coordination	DEV/DEX
4.2	Support Agreements (Medical, EOD, Photo, Corp, Machinists, Weather, PMEC)	DEV/DEX
4.3	Transportation, Shop Services, Supply	DEX/DEV

AFWL-TR-75-249

<u>TASK/SUBTASK</u>	<u>DESCRIPTION</u>	<u>BRANCH (OPR/INPUTS)</u>
4.1	Imprest Funds	DEX/DEV
5.0	Project Report	DEV
5.1	Data Reduction/Analysis	DEV/DEX
5.2	Geological Data	DEV
5.3	Environmental Effects	DEV/DEE/WE
5.4	Free Field Environment	DEV
5.5	Structures	DEV
5.6	Instrumentation	DEX

SECTION VI  
TEST SCHEDULE

The requirement exists to complete the HARD PAN I test series by December of 1975. The scheduling of events is therefore, very tight and successful completion of the test series is dependent upon strict adherence to the timetable of figure 27.

At the time of this writing the first two events, HPI-1 and HPI-2A, have already taken place. HPI-1 occurred on 24 October 1974 and HPI-2A on 19 December. HPI-2B is presently scheduled for 27 August 1975. HPI-3 is tentatively scheduled for 4 December 1975.

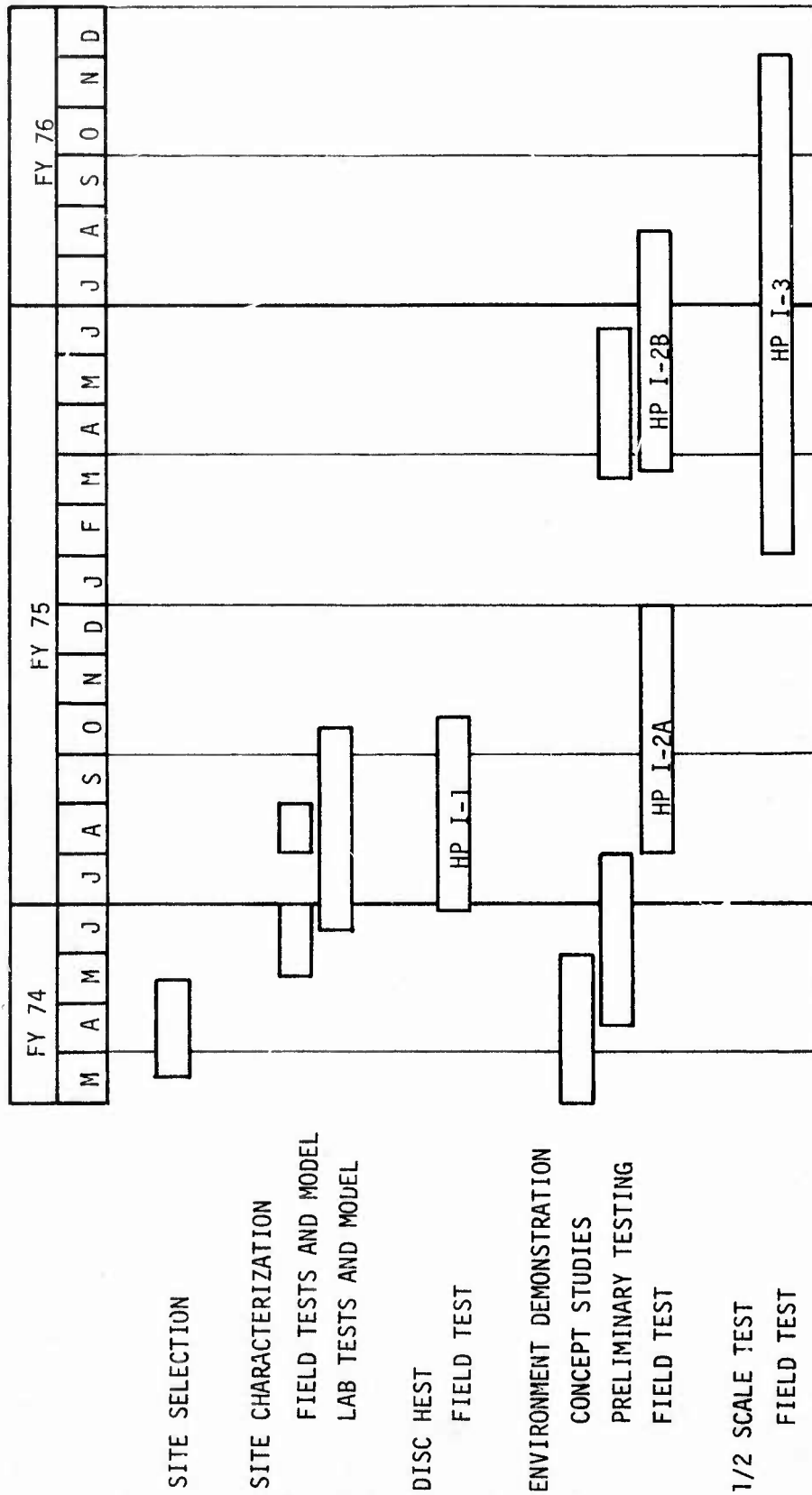

Figure 27. HARD PAN I Timetable

APPENDIX A  
SECURITY CLASSIFICATION

The following security classification guidelines apply to the HARD PAN test series and results thereof:

- |   |   |
|---|---|
| 1. Construction details, test plans, and test objectives  | UNCLASSIFIED                            |
| 2. Test site geology and material properties  | UNCLASSIFIED                            |
| 3. Detailed comparison between test site properties and any portion of MM force   | Assumes classification of MM properties |
| 4. Individual test traces showing the environment simulation performance time history   | UNCLASSIFIED                            |
| 5. Compilation and analysis reports which compare simulation performance with nuclear predictions   | C-XGDS-3                                |
| 6. Extrapolation of simulation environment results to any portion of the MM force   | S-XGDS-3                                |
| 7. Individual test traces showing structural response time history  | UNCLASSIFIED                            |
| 8. Compilation and analysis of structural response and system transfer functions  | C-XGDS-3                                |
| 9. Extrapolation of structural response data to any portion of the MM force   | S-XGDS-3                                |
| 10. Calculation of tests without comments or annotations  | UNCLASSIFIED                            |
| 11. Comparison between calculation and test results   | C-XGDS-3                                |
| 12. Extrapolation of calculations to any portion of the MM force  | S-XGDS-3                                |
| 13. Results of static component tests   | S-XGDS-3                                |
| 14. Test data, including pictures and components themselves, which indicate structural distress or weaknesses which can be interpreted as a failure mode or failure mechanism | S-XGDS-3                                |

APPENDIX B  
SECURITY PLAN

1. PURPOSE

The purpose of this document is to describe the plan, responsibilities and implementation procedures for providing security measures for the HARD PAN I series of explosive events in Linn County, Kansas.

2. SCOPE

The scope of this security document is limited to control of personnel, equipment, explosives and vehicles arriving, leaving and existing within the test area, and the safeguarding against theft and sabotage of Government-owned equipment and materials.

3. RESPONSIBILITIES

a. Each contractor employee and military person shall read, understand, and comply with all Federal and/or company regulations and requirements made available to him.

b. Each contractor employee and military person is responsible for the safeguarding and protection of his individual property and the property of the Government entrusted to him.

c. Each contractor employee and military person on the HARD PAN I project is responsible for reporting any security infraction, violation, and/or theft to his supervisor or the Security Guard on duty.

d. The individual's supervisor is responsible for reporting any security infraction, violation, and/or theft brought to his attention to the Security Guard on duty and/or the HARD PAN I Test Conductor.

e. Failure on the part of the individual or his supervisor to make a prompt report may of itself be considered a security infraction or violation.

f. The Security Service hired to protect the HARD PAN I test site area is responsible for reporting, investigating, evaluating, recording, and submitting such reports as are appropriate on all security infractions, violations, or thefts. All such activity will be closely coordinated and accomplished in complete cooperation with the local and military law enforcing offices.

g. The Test Conductor is responsible for counseling all contractor employees on all security matters applicable to Government-owned material and facilities, and is responsible for reporting suspected security infractions, violations, or thefts to the proper military and civilian authorities.

4. GENERAL SECURITY

A fence encloses a large tract of land of which the HARD PAN I test area is a part. Appropriate "Controlled Area" signs will be located along the fence. A gate equipped with a lock shall control access at the roadway entrance. At the end of each duty day, all trailers, tool sheds and equipment shall be locked to preclude theft or tampering. A security guard service shall be contracted to patrol the site 24 hours a day.

5. PROCEDURES FOR CONTROL OF PERSONNEL INTO AND OUT OF THE TEST AREA

a. An access list of all contractor and military personnel will be provided to the Security Guards by the Test Conductor. This list will be updated as required.

b. Names of all personnel entering the Site will be checked against the access list to determine admittance approval.

c. Persons whose names are not on the access list shall be denied admittance into the area unless cleared by the Test Conductor.

6. PROCEDURES FOR HANDLING REPORTING OF THEFT

a. Upon discovery of a theft of Government resources, the Test Conductor shall be notified.

b. Upon notification of theft, the Security Guard supervisor shall report to the test site.

c. On direction from the Test Conductor the Security Guard Service will immediately begin investigation of the theft, working in cooperation with local and military authorities, and will prepare a report describing the nature of the theft, the circumstance, and remedial actions taken. This report shall be submitted in triplicate within 24 hours to the Test Conductor.

7. PROCEDURES FOR CONTROLLING OF PERSONNEL AND VEHICLES IN CASE OF PERSONNEL INJURY ON THE TEST SITE

a. In the event of personnel injury on site, the Security Guard will assist as required.

b. If ambulance services are required, the Security Guard shall permit the ambulance and driver immediate access into the test area without delay.

c. The Security Guard shall control personnel and vehicle traffic in the immediate area in a manner required to expedite medical attention to the injured.

8. PROCEDURES FOR MONITORING THE TEST AREA

a. Area monitoring will be accomplished by patrolling the immediate test area, office and instrumentation trailers, and explosive storage area. The Security Guard will not patrol the fence.

b. The standard security guard shifts will be from 8 a.m. (0800 hrs) to 4 p.m. (1600 hrs), from 4 p.m. (1600 hrs) to midnight (2400 hrs), and from midnight (2400 hrs) to 8 a.m. (0800 hrs).

c. Area monitoring will be performed every hour during non-duty hours.

d. The Security Guard will record in the daily log all observed and reported incidents relating to lack of security and safety.

e. The Security Guard Chief will notify the Test Conductor of any observed or reported incident.

9. EXPLOSIVES SECURITY

a. Explosives will be stored on the test site only when actually required for assembly and installation into the BLEST or HEST prior to conducting a test.

b. Quantities of explosives stored will be maintained at the minimum level necessary to support current requirements. Excess explosives will be returned to the appropriate Air Force munitions storage area for storage.

c. Except during assembly operations, all explosives, other than the AN slurry, will be secured in the storage structures in the explosive storage area until they are to be placed in the test bed. AN slurry will be stored in the explosive storage area or near vicinity and will be under the surveillance of a security guard.

d. At all times when explosives are present, an armed security guard will provide security for the test site. During non-duty hours a second armed guard will maintain constant surveillance of the explosive storage area.

e. Structures being used for the storage of explosives will at a minimum have an audible alarm which can be heard anywhere on the test site should unauthorized entry be attempted. Alarms will be tested daily. Additionally, structures will be locked with double locks and reinforced as necessary to prevent entry. Keys will be controlled by the site explosive safety officer.

f. Should a situation arise involving the security of explosives beyond the capability of the on-site security personnel, back-up assistance will be requested from the appropriate state or local law enforcement personnel or the security guard service.

APPENDIX C  
SAFETY PLAN

1. PURPOSE

This Safety Plan establishes the safety areas for the Structure Medium Interaction Test Program. The detailed safety rules which are applicable to this project are documented herein. The following safety documents are applicable:

AFM 127-100  
AFM 127-101  
AFM 127-4  
USA Corps of Engineers Manual EM 385-1-1  
Dept. of Labor, Part 1910, Occupational Health  
and Safety Standards (OSHA).

2. OVERALL SAFETY RESPONSIBILITY

The Air Force Weapons Laboratory is responsible for enforcing the overall safety program for HARD PAN I. The authority to execute the program is delegated to the Test Director. This plan has been coordinated with and includes the safety requirements for AFWL and the contractors. The AFSWC Explosive Safety Officer is the safety officer for AFWL for this test.

3. SAFETY AREAS

The safety requirements for HARD PAN I have been divided into three separate and distinct areas to facilitate the establishment of specific requirements for the different areas of operation. The three areas of safety requirements are listed as follows:

- a. General Safety
- b. Construction Safety
- c. Explosives Safety

4. GENERAL SAFETY

The responsibility for general site safety resides with the AFWL. The authority to execute specific safety directives is delegated to the Test Conductor.

- a. Daily Safety Briefing

It is the responsibility of military and civilian supervisors to thoroughly brief their personnel at the beginning of each work day on safety

hazards existing on the site or expected during the day. Personnel arriving on site after the formal briefing shall be individually briefed by their supervisor. Construction progress, work planned and present or near future job site hazards shall be discussed near the end of the working day with the following minimum personnel:

- (1). Test Conductor (or representative)
- (2). Site Development Supervisor
- (3). Field Operations Supervisor
- (4). QC Supervisor
- (5). Site Support Supervisor
- (6). AFSWC Safety Officer

b. Visitors

Visitors shall not be allowed in the Test Facility area and/or Ordnance Area without approval of the Test Conductor or his authorized delegate. Visitors shall be instructed in the area safety regulations, general hazards and site peculiar hazards by the Test Conductor, then shall be escorted as necessary for administrative, safety and security reasons. Escorts will be AFWL personnel who have complete site familiarity.

c. Daily Inspection Tour

The Test Conductor, AFSWC Explosive Safety Officer and a member of the general contractor's supervisory staff together shall inspect the entire construction site (including all high explosive areas) at the end of each working day to insure that no hazards (fire, electrical, equipment, etc.) exist. Any hazards which are discovered will be immediately corrected before leaving the site. An inspection checklist shall be completed at the end of the inspection tour to reflect any problems encountered and the corrective measures taken.

d. Individual Safety Responsibility

It must constantly be kept in mind that safety equipment and safety rules and regulations cannot be substituted for good working practices. Careful attention to the hazards on a construction site and the potential hazards involved in work dealing with explosives must be stressed in all levels of responsibility. The purpose of the safety rules outlined herein is to present the most important precautions to be taken in operations involving explosives and construction. These rules do not cover all the possible hazards or safety precautions necessary at the site. As new problems arise, new safety measures will be established to cope with them. In the interim, common sense must be applied to insure that safety prevails. This entire Safety Plan must be closely followed by all personnel and enforced by all supervisors. The procedures contained herein shall be accepted as minimum standards until such time as the Test Conductor, with the concurrence of the AFSWC Explosive Safety Officer authorizes deviation therefrom.

e. Vehicles

Caution shall be exercised while driving to and from the test site. Speeds shall not exceed 55 mph on paved roads and shall not exceed 30 mph on unpaved roads. Within the construction area, the speed shall not exceed 15 mph. Personnel who are extremely fatigued shall not attempt to drive a vehicle. Seat belts will be used at all times while a vehicle is in motion. When parking a vehicle, the hand brake will be set and the transmission will be put in park or reverse. Two wheels shall be chocked, if the vehicle is on a grade. No vehicle shall be left unattended with the motor running.

f. Accident and Emergency Procedures

(1). Scope

This standard procedure is intended to serve as a guide to insure expedient handling and care of personnel injured as a result of an accident or disaster. All "post emergency" reporting and investigation of an accident will be performed in accordance with existing pertinent Air Force Regulations and is not considered to be within the scope of this standard procedure.

(2). Responsibility

It is the responsibility of every person involved in this program to be completely familiar with the emergency reporting procedures established by this plan and to implement these procedures immediately in the event of an accident. It is the responsibility of the Test Conductor to familiarize all AFWL personnel and non-AFWL supervisors with this standard procedure. It is the responsibility of the supervisors, in turn, to familiarize subordinate personnel with the procedures established by this plan.

(3). Emergency Procedures

In the event of an emergency at the HARD PAN I test site, the following procedures will be followed.

(a) Emergency Signal

Conditions requiring complete emergency evacuation of the test bed shall be signaled by a 1 minute wavering tone from a siren located in the construction area. If time permits, the Test Conductor shall be notified prior to sounding the siren. The evacuation signal shall be activated by the senior supervisor present in the construction area. The Test Conductor shall insure complete evacuation of the test bed area. Three 5 second blasts will be the all clear signal.

(b) Emergency Egress Routes

In the event a condition arises where an emergency evacuation of the work site becomes mandatory, personnel will exit via the shortest (safe) route to a half mile or more from the test bed. Personnel shall wait for the all clear signal before returning to the test bed.

(4). Injury Procedures

The senior supervisor at the scene of a major accident will direct appropriate first aid. Caution will be exercised to prevent aggravation of an accident related injury.

(a) The Test Conductor, or in his absence the senior supervisor, shall determine the seriousness of an accident. If it is determined that the accident is not serious enough to require emergency hospitalization or ambulance service first aid will be administered at the site. If further medical attention appears necessary, the injured person will be taken to a doctor or hospital by normal transportation means.

(b) For serious accidents, the nearest medical facility will be immediately notified by telephone. The nature of the accident, including apparent condition of injured personnel and the location of the test site, will be reported to the medical personnel. The Test Conductor, or in his absence the senior supervisor shall determine whether to attempt transfer of the injured to a hospital or to request emergency ambulance support.

g. First Aid

An adequate supply of first aid items will be maintained in the office trailer at the site. These items will be properly stored and periodically inspected to insure their adequacy in the case of an emergency.

h. Snakes

Personnel will be on the alert at all times for rattlesnakes, copperheads and water moccasins on the test site. Particular caution will be used when moving stacks of construction material.

Poisoning from snake venom is a medical emergency which requires immediate attention and the exercise of considerable judgment. Delayed or inadequate treatment for venomous snakebite may have tragic consequences. On the other hand, failure to differentiate between bites of venomous and non-venomous snakes may lead to use of measures which bring not only discomfort to the individual but may produce deleterious results. It is essential that the one responsible for treatment establish whether or not envenomation has occurred before treatment is started. A venomous snake may bite and not inject venom. Also, some persons bitten by non-venomous snakes become excited and even hysterical. These emotions may give rise to disorientation, faintness, dizziness, rapid respiration or hyperventilation, rapid pulse, and even primary shock--all symptoms and signs which may occur following envenomation.

Treatment, to be effective, must be instituted immediately following the bite and must include measures:

1. To retard absorption of the venom;
2. To remove as much venom as possible from the wound;
3. To neutralize the venom;
4. To prevent or reduce the effects of the venom; and
5. To prevent complications, including secondary infection.

5. CONSTRUCTION SAFETY

The safety procedures defined by this Safety Plan and any supplemental safety directives shall be enforced by the Test Conductor. The contractor shall conform to the safety standards as specified in this plan or in OSHA, which ever is more stringent.

a. Protective Clothing

Hard hats and hard toe shoes will be worn by all personnel working in the construction and drilling areas on site. Dust masks will be worn by all personnel during severe dust conditions.

b. Smoking

No Smoking areas will be clearly indicated by signs. Strict enforcement of "No Smoking Areas" will be observed.

c. Open Trenches and Excavations

All open trenches, ditches and shafts will be barricaded at all times when work is not actually being done on or in them. Flasher lights will be attached to the barricades during the night. Open flames shall not be used on the site to illuminate the barricades. Shoring shall be used in all excavations where personnel will be working below ground level.

d. Construction Equipment

Protective shields shall be used on all power tools and personal protective devices shall be used when operating the tools. All electrically powered equipment shall be grounded using three wire plugs.

(1) Welding Equipment

Unprotected personnel shall be kept out of the area of welding operations. Welders shall be equipped with proper face shields and body protection.

(2) Machine Shop

Safety rules for machine shop shall be posted. Only qualified operators shall be allowed to operate these machines. Safety guards shall not be removed when operating any machine. Machines and surrounding area will be cleaned after each use.

6. EXPLOSIVES SAFETY

The Test Conductor will have complete authority for the enforcement of all safety requirements and procedures pertaining to the on-site handling, storage, and transportation of any high explosives used in this program. These requirements will be specified below.

a. High Explosives Handling, Storage, and Transportation

(1) Scope

This plan will define the procedure and provide the guidance required in the handling, storage, and transportation of the high explosives used in this program.

(2) Responsibility

The Test Conductor will assume responsibility for insuring that all on-site safety procedures are observed. Individual personnel will be responsible to be completely familiar with all safety procedures dealing with explosives before entering an area containing these materials. Explosive ordnance personnel will have prime responsibility for the transportation, handling, and installation of all explosives.

(3) Personnel Limits

Due to the unique nature of the test requirements, the personnel limits will be established and controlled by the Test Conductor at the test site with the concurrence of the Safety Officer.

(4) Explosives

The explosives to be used fall into four categories: detonating cord, detonators, boosters, and AN slurry.

(a) Detonating Cord

Detonating cord in 400-grain/ft and 60-grain/ft sizes is used for two different purposes in the test series. The 400-grain/ft detonating cord is "woven" together to provide the explosive charge for the HEST while the 60-grain/ft detonating cord is used in the firing system for the BLEST. A maximum of 750,000 feet (42860 pounds explosive weight) of 400 grain/ft and 325,000 feet (2785 pounds explosive weight) of 60 grain/ft will be used for the test series. The explosive used in the detonating cord is Pentaerythritol Tetranitrate (PETN).

(b) Detonators

Exploding Bridgewire Detonators (EBW), each containing approximately 5 grams of explosive, are used to initiate the explosive system in each test. They are detonated electrically by a high energy firing system controlled from the instrumentation van.

(c) Boosters

Explosive boosters are used as a priming charge for the AN slurry. Each booster consists of 12 ounces of pentolite explosive. A maximum of 4400 (3300 pounds explosive weight) will be used for the test series.

(d) AN Slurry

This is a nitrocarbonitrate (NCN) aluminized slurry which is used as the main charge for the BLEST. A maximum of 300,000 pounds will be used for this test series.

(5) Site Selection

The test Conductor and the Explosive Safety Officer will locate areas for instrumentation trailers, and an observation post (OP) for spectators during the test taking into account ground shock, overpressure and hazardous fragment distance data. The instrumentation trailer will be located 1200' (min) from GZ, and the (OP) 24000' (min) from GZ.

(6) Storm Procedure

In the event of winds exceeding 35 knots personnel shall secure loose pieces of equipment and material. If lightning occurs within 3 miles of the site when explosives are present the area shall be evacuated to a distance of at least 1/2 mile from the explosives. The test bed shall be evacuated to a distance of at least 1/2 mile. Personnel shall wait for an all clear before returning to the test bed area.

(7) Storage of Explosives

(a) Explosives will be stored in accordance with Air Force explosive safety requirements.

(b) Storage, assembly, and test bed areas will be designated no smoking areas when explosives are present.

(c) All explosives will be stored in the explosive area designated by the Test Conductor and the Explosive Safety Officer.

(8) Handling of Explosives

(a) All handling/assembly of explosives or explosive assemblies will be done by qualified personnel aware of the necessary explosive safety precautions.

(b) The Explosive Safety Officer will monitor all activities involving explosives to insure that safe procedures are being followed.

(9) Misfire Procedure

Should a misfire of the primary explosive system occur, no person will approach the test area for a minimum of 30 minutes. The Test Conductor will direct the Ordnance Engineer to execute his misfire procedure. The Test Conductor will then, with the concurrence of the AFSWC Explosive Safety Officer, direct the EOD team to proceed to the test bed and remove the firing lines. The cause of the failure will be determined and corrected. (Test controllers and ordnance system misfire procedures are attached to this safety plan.)

(10) Partial Detonation

In the event of an obvious partial detonation, a 30 minute safety period will be observed. If there are burning explosives in the test area, no one will approach the test area for at least 2 hours after the last visible signs of burning. The first to enter the area will be an EOD team and the AFSWC Explosive Safety Officer. The Test Conductor will perform a survey with the Explosive Safety Officer and direct appropriate measures to be taken. (Undetonated explosives will be disposed of in the most appropriate manner as determined by the EOD team).

b. Open Flame and Sparks

No open flame or spark generating devices will be permitted in any high explosives handling or storage area.

c. Explosives Transport Vehicles

(1) Vehicle Specifications

Vehicles utilized for transportation of explosives will conform to the provisions of the Air Force Explosives Safety Manual, AFM 127-100. They will carry explosive placards appropriate for the type of cargo.

(2) Vehicle Inspections

Prior to transporting explosives over the public highway, the DD Form 836 (Special Instructions for Drivers) and DD Form 626 (Inspection Report Motor Vehicle Transporting Class A and B Ammunition and Explosives over Public Highways) will be completed. These forms will be completed in duplicate, one copy being submitted to the Test Conductor and the second copy being forwarded to AFSWC (SE), Kirtland AFB, New Mexico. Prior to transporting explosives, a vehicle inspection will be made.

7. NOTIFICATION

The Test Conductor will furnish a time schedule of the test firing to the AFSWC Safety Officer at least 5 working days prior to the actual firing. The AFWL Test Conductor will be responsible for contacting the necessary agencies 24 hours prior to the test.

Access roads to the test site will be barricaded as required and positive control of personnel on the test site will be maintained.

APPENDIX D  
COMMUNICATION PLAN

1. TASK ORGANIZATIONS

Air Force Weapons Laboratory/Civil Engineering Research Division  
4900th Test Group/FTTP  
4925th Field Maintenance Squadron/LGMFME  
Air Force Special Weapons Center/SE  
U.S. Geological Survey  
Sandia Corporation  
Det 9, 37th Air Rescue Squadron  
Site Security Service Contractor  
1840 Air Base Wing/DEF/SG

2. SITUATION

The Air Force Weapons Laboratory Civil Engineering Research Division (AFWL/DE) is the responsible agency for the HARD PAN I test series which will be conducted in the Trading Post, Kansas vicinity from June 1974 thru December 1975. Event 1 was conducted on 24 Oct 1974. Event 2A was conducted on 19 December 1974. Events 2 B and 3 are scheduled for 27 August 1975 and 4 December 1975 respectively. A controlled firing area (CFA) has been established by the FAA within one statute mile radius of latitude 38°14'30"N, longitude 94°38'30"W. The time of use for this CFA is from 1100 hours to 1500 hours CST each shot date. The AFWL will provide continuous visual surveillance within a five mile radius during the time that activities hazardous to aircraft are in progress.

3. COMMUNICATIONS CONTROL

The Test Control Center van shall be the communications center for all events. The communications network for HARD PAN I is shown in Figure D-1.

4. SITE WARNING

A siren, located in the trailer shelter area, shall be used as a warning device. The following signals shall apply:

- a. 1 minute, wavering tone - evacuate test bed
- b. Three 5 sec blasts - all clear
- c. 3 sec blast - T-10; T-5; T-1 minute(s) warning

5. SAFETY NET

The designated frequency for all safety-related activities shall be 149.205. AFSWC/SE shall coordinate these activities for the test controller.

6. OPERATIONS NET

Participating activities which cannot be wired into the countdown net due to distance or mobility shall use the frequency 148.515.

7. COUNTDOWN NETWORK

Instrumentation vans in the trailer shelter area shall be hardwired to the TCC van for communications and switch closures.

8. TELEPHONE

Telephone communications shall be maintained in the office van until T-0:45:00 with FAA, Richards Gebaur AFB, Whiteman AFB, and for range micro-barograph operators/aerial observers.

9. UHF

Helicopter control will be maintained by a UHF radio operator.

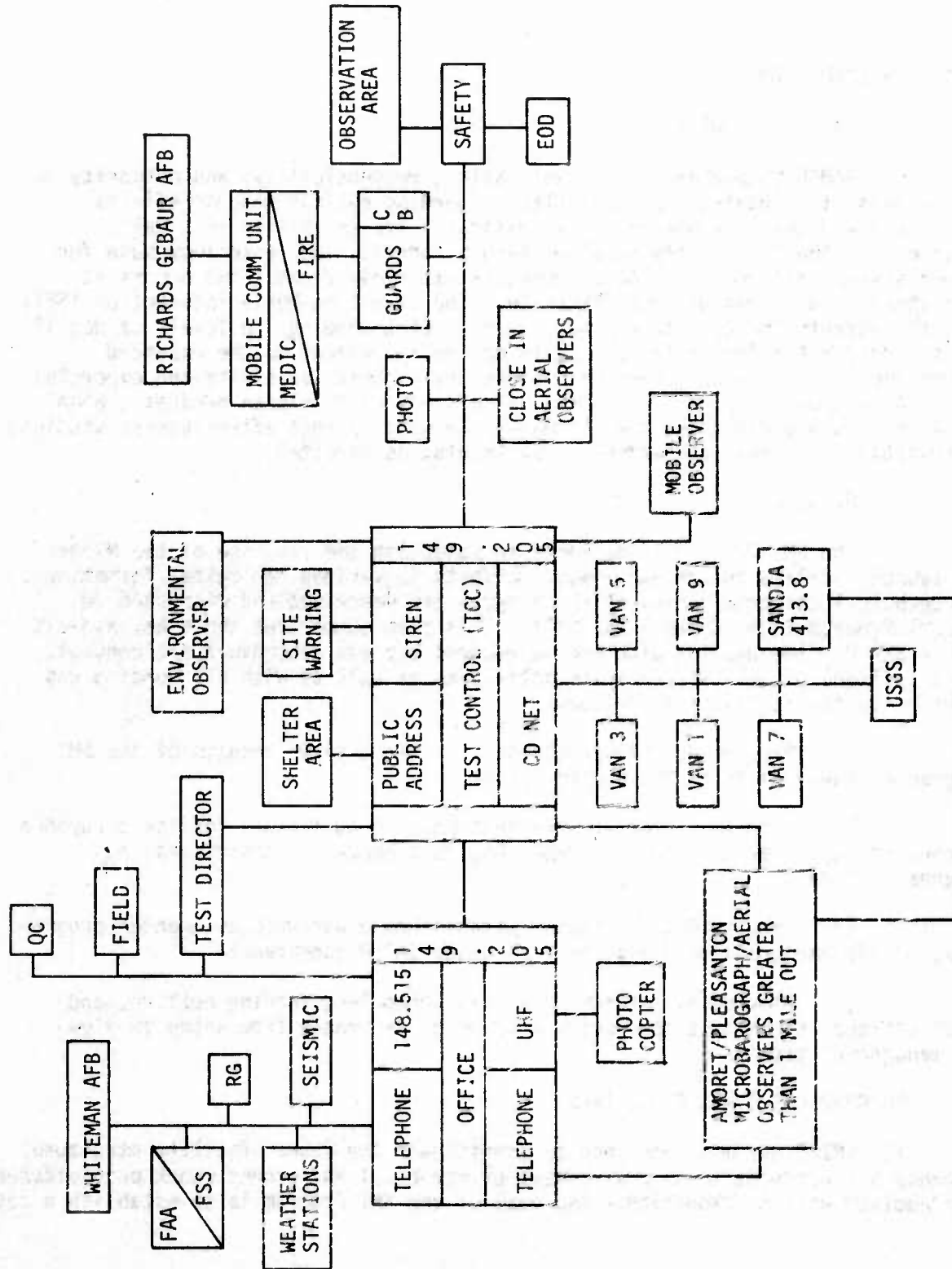

Figure D-1. HARD PAN I Communications Network

APPENDIX E  
SAMS0/AFWL AGREEMENT

1. INTRODUCTION

a. Motivation/Utility

SAMS0/Minuteman has the obligation, responsibility, and authority to ensure that it maintains its credibility regarding nuclear weapons effects technology and that the weapon system maintains its capability as a valid deterrent in the face of any possible future threat. The technology base for weapon system refinement and development is extremely dynamic and occurs at ever increasing levels of sophistication. The Structure-Media Interaction (SMI) Program presents the opportunity to determine phenomenology to levels of detail and accuracy not before attainable. To optimally respond to the enhanced future threats, it is necessary to possess the highest capability and expertise possible in order to provide accurate definitions of Minuteman hardness, when required. Such definitions may ultimately be used in cost effectiveness studies, modernization designs, or hardness assessments, as directed.

b. Purpose

The SMI Program is designed to establish the response of the Minuteman launch facility to nuclear weapons effects in various geological formations. The technical characteristics of the program are described and discussed in the SMI Program Plan, dated 1 May 1974. This plan summarizes those key aspects of the SMI Program dealing with the management process (coordination, control, and direction) of test and analysis activities as well as with all funding and program liaison functions as follows:

(1) Program Goals/Objectives: Defines desired results of the SMI Program as they relate to the weapon system

(2) Program Approach: Provides minimum guidelines for the assurance of consistency in program conduct regarding to precedents, priorities, and program rationale

(3) Program Organization: Establishes a workable documented program relationship among all involved agencies under SAMS0 cognizance

(4) Program Milestones: Devises schedules, funding outline, and organizational schematics to provide a frame of reference from which to view the management process

2. PROGRAM GOALS AND OBJECTIVES

The SMI Program is designed to investigate the launch facility structural response and hardness to an environment of air blast and ground shock precipitated by a nuclear weapon detonation. The goal of the SMI Program is to establish a set

of prediction techniques capable of providing site-by-site response and hardness definition of a launch facility for the range of geological and nuclear burst conditions appropriate to Minuteman. The technical objectives of the program are to (1) evaluate two-dimensional prediction techniques (2) develop three-dimensional prediction techniques (3) develop facility subsystem response predictions.

### 3. PROGRAM APPROACH

The SMI Program is composed of two parallel and interrelated efforts; analysis and test. Real-time utility of the program depends on the complete synergism of these efforts. The overall scope of the test portion of the program is shown in Figure E-1. The analytical portion is designed to complement the test program in a manner in which the technical objectives can be met. In the investigation of SMI phenomenology in this program three general classes of media will be considered; viz., dry granular (A), wet clay/shale (B), and wet clay/interbedded shale over limestone (C).

#### a. Two-Dimensional Air Blast Effects

The initial refinement and evaluation of a two-dimensional prediction is essential, so that a firm foundation is established from which a logical procession to the three-dimensional problem will take place. The DISC HEST test considers an axisymmetric loading on a 1/4-scale structure in a C medium. The test will be designed to simulate IMT near surface height of burst condition for the 1200 psi range. The DISC HEST results for the recently completed GRABS series (which considered an A medium), will provide the necessary data to determine the two-dimensional pressure and related effects (PARE) prediction capability. This capability will be developed through test/analysis correlations and through the synthesis of results of two-dimensional parametric analysis studies for the range of conditions applicable to Minuteman.

#### b. Three-Dimensional Air Blast Effects

(1) The first Enhanced-HEST will be in the C type of medium and will contain a 1/2-scale structure. The Enhanced-HEST tests will employ a simulation of the environment due to air blast induced ground motion environment from the close-in high overpressure region in addition to the overhead air blast HEST simulation. The analytical approaches in the studying of three-dimensional PARE will include the development of a three-dimensional SMI computer code capability. Such development is quite important to this program.

(2) One-half scale Enhanced-HEST tests will be performed in both the C and B types of media in order to understand and quantify the effects of geological variations on the SMI phenomenology. The three-dimensional PARE prediction capability will be based on parametric analytical studies using the three-dimensional code and analytical extrapolations of the experimental test results.

c. Structural Component Hardness Test

A series of tests on individual structural components on sections of the launch facility will be conducted. These tests together with a companion analysis effort will provide the basis for development of fragility relationships for critical structural components.

d. Three-Dimensional Air Blast and Crater-Related Effects

Even though funding provisions have been made for only PARE phenomenology studies, the possible SAMSO participation in the DNA effort "DICE THROW" is directed towards the study of crater and related effects (CARE), resultant from an HE detonation. The applicability of the DICE THROW environment, as it pertains to Minuteman requirements, is uncertain and will be reevaluated when the experiment is better defined. It is recognized, however, that CARE should be investigated before the program can be considered fully effective for the wide range of SMI phenomenology and weapon threats of the future.

MEDIA	AI AXISYMMETRIC	AI TRAVELING	AI/DI 3D
DRY GRANULAR	A GRABS		SPHERICAL
WET CLAY/SHALE		B ENHANCED HEST (1/2 SCALE)	HE DICE THROW
WET CLAY/ INTERBEDDED SHALE OVER LIMESTONE	C DISC HEST (1/4 SCALE)	C ENHANCED HEST (1/2 SCALE)	(MEDIA TBD)

FIGURE E-1

4. PROGRAM ORGANIZATION

a. General

(1) The Minuteman Vulnerability and Hardness Division (SAMSO/MNNH) will maintain responsibility and authority for SMI program direction with DEB acting in a line advisory role, as does TRW and AFWL/DEV.

(2) The nature and scope of the test portion dictates that an efficient, experienced and proven organization be responsible for the conduct of that effort. Accordingly, the Air Force Weapons Laboratory (AFWL) has agreed to direct the SMI field test program complying with the overall procedures and guidelines agreed to with SAMSO and contained within this plan.

(3) The analysis portion of the program will be functionally managed by the Norton Division (DEB), Directorate of Civil Engineering with AFWL as a technical advisor and TRW as the Systems Engineering and Technical Direction Contractor. Since a number of contractors will participate in the analysis program, it is imperative that sufficient managerial attention be related to the coordination activities of that effort. It is imperative that data generated by all agencies be distributed and utilized as soon as feasible in the attainment of the SMI technical objectives. Large technology programs tend to self-generate, providing more information that can be utilized, if the assessment of the results is dismissed until program completion. Provisions must be made for the correlation and utilization of data at nearly the same rate that it is generated. Specific management monitoring of all contractor activities is essential to this end. Dynamic monitoring flow diagrams will be established to implement such management principles. Accordingly, DEB, under "Memorandum of Understanding" with the Minuteman Engineering Division (MNN), will provide the appropriate line personnel to manage the analysis portions as well as all associated interface activities with the test portion of the program.

(4) The following is provided as the functional organizational schematic for the overall Minuteman SMI Program:

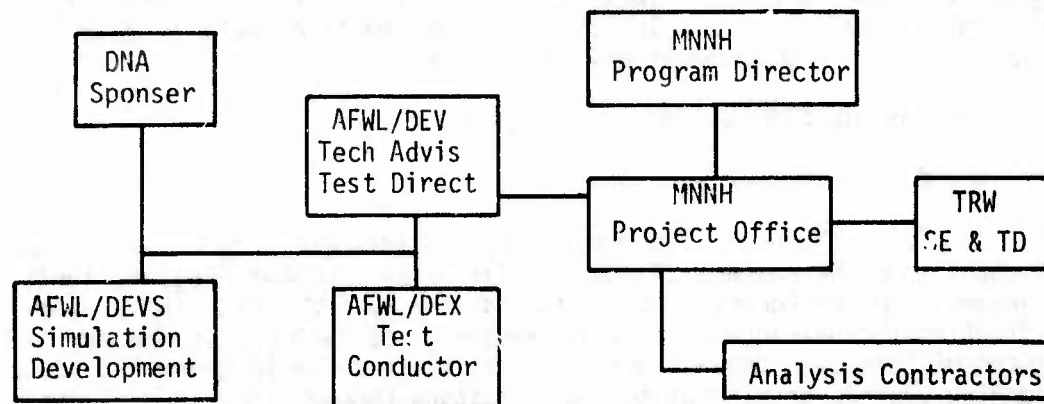

FIGURE E-2

b. Test Responsibility/Authority

Within the test program, AFWL, the test director and conductor, will maintain overall managerial authority and responsibility. SAMSO and AFWL will define the test plan in order to fulfill the objectives of the total analysis and test program. SAMSO has the responsibility to insure that it is cognizant of detailed test conduct and may, at anytime, provide recommendations as to the nature of such testing.

c. Analysis Responsibility/Authority

Even though the test and analysis portions of the SMI Program are interrelated with respect to the information processed and utilized by each, the analysis portion can be described and managed as a parallel program for the purpose of funding, contractor liaison activities and program direction. Prime responsibility for the management of this portion is delegated to DEB which also maintains the corresponding authority to define and direct contractor efforts with the concurrence of, as in all instances, MNNH. AFWL, in addition to conducting SMI analysis, shall perform the staff function as technical advisor in assessing the direction content and interaction of various facets of the analysis portion.

d. Communication

Inherent in an effective management process is a dedicated effort to monitor all program facets while optimally communicating with all line and staff functions concerned with program conduct. Such communications allow useful feedback from all organizations providing necessary information in a systems approach to program management. Accordingly, it shall be the responsibility of the SAMSO and AFWL SMI project officers to insure an effective and efficient exchange of planning and status information among all program agencies and contractors with regard to analysis and test respectively. Such an exchange must occur in a timely manner so that all organizations may impact program conduct. While it is imperative to establish effective lines of communication, it is as equally desirable to maintain flexibility in an effort to respond to transient program intensity. In consonance with the desire to provide a foundation for an effective information exchange system, Technical Interchange meetings shall be conducted by SAMSO in order to respond in real time manner to program requirements while affording the opportunity for the necessary dialogue among program participants. The need for such meeting shall be determined by the dictates of the program at any given time.

5. PROGRAM MILESTONES (Refer to Figure E-3)

a. Test

(1) Schedule: The content of the SMI test program is, in part, contingent upon the outcome of the Simulation Development Program, funded by the Defense Nuclear Agency (DNA) and conducted by AFWL/DEV. The purpose of such an effort is the development of a technique to be included in the two 1/2 scale Enhanced-HEST tests, adequately representing the close-in generated air blast, outrunning signals propagated to the structure through lower media layers.

(2) Funding: All test funding is provided by SAMSO/MNNH Project Element LC and will be forwarded under appropriate procurement directives (PD) to AFWL/DEV, the test manager and office of prime responsibility (OPR). Funding for the entire program is generated from MNP, as requested by MNNH through MNNH. Funding for all Minuteman programs is reviewed in June and February of each year in order to incorporate program changes, additions, and deletions. The milestone chart, therefore, reflects those allocations resulting from the February 1974 project element budget presentation.

b. Analysis

(1) Schedule: The associated effort in developing a three-dimensional prediction technique bridges the entire test schedule. Accordingly, the development of a 2D prediction technique will be completed and evaluated through pre- and post-test correlations with the axisymmetric DISC HEST test. The development of a 3D technique will proceed throughout the test program and evaluated in pre- and post-test calculations of the major test events and concluding with a final verified product by June 1977.

(2) Funding: All contracts, procurement directives, military inter-departmental purchase requests, obligation authorities and the like for the analysis portion of the SMI Program shall be processed through MNC and remain under the cognizance of the Minuteman SMI Project Office (MNNH). Since several as yet undefined contractors will be participating in the program, funding is detailed below only by fiscal year. Funding can be allocated to individual contractors as requirements dictate.

NOTE: This appendix reproduces, except for slight format changes, the contents of the document entitled "Minuteman Structure-Media Interaction Program Management Plan", dated 15 March 1974.

		FY-74	FY-75	FY-76	FY-77	TOTAL	
TOTAL FUNDING		SAMSO	590K	2460K	1950K	1200K	6090K
		DNA		1000K			1000K
T E S T	SIMULATION DEVELOPMENT (DNA)	▽	▽	▽	▽		
	DISC HEST (1/4 SCALE)	▽	▽				
	DICE THROW (DNA)		▽	▽			
	ENHANCED HEST (1/2 SCALE)		▽	▽	▽		
		SAMSO	965K	2030K	1500K	1000K	5475K
		DNA		1000K			1000K
A N A L Y S I S	2-D PARE	▽	▽				
	3-D PARE		▽		▽		
	3-D PARE/CARE			▽	▽		
		SAMSO	80K	430K	450K	200K	1060K

Figure E-3. Program Milestones

APPENDIX F  
PHOTO PLAN FOR PROJECT HARDPAN I

1. GENERAL

Photographic support is needed to provide documentation of activities on the HARD PAN I site both before and after each event and to provide high speed motion picture coverage during each event.

2. PRE AND POST SHOT DOCUMENTARY FILM REQUIREMENTS

Both still and motion pictures are needed for documentary purposes for each of the three events. All film must be labeled and kept in chronological order. Date, time, location, and event number or object title must be included in at least one view. An unclassified, edited and narrated film summarizing all three events is required.

3. EVENT PHOTOGRAPHIC COVERAGE

a. Tower Mounted Cameras

Cameras will be located in towers to provide both high speed and normal coverage of the test site at detonation. Tower locations for each of the events shall be documented in the instrumentation plan.

b. Helicopter Carried Cameras

A helicopter provided from Whiteman AFB, Mo. will be flown at such an altitude and range from each test as to provide photo coverage from a slant range of 3000 feet and 30° to 45° above the horizon. The following manually operated cameras are required in the helicopter.

1. One 400 fps movie camera focusing on the overburden.
2. One 70 mm Hasselblad camera to shoot a rapid sequence of stills and to provide before/after photos to show debris patterns.

c. Structure Mounted Cameras

One 1500-2000 fps and two 400 fps movie cameras with 100 pps timing generators are required for each event. Long time duration ( $\approx 1.5$  sec) flashbulbs are necessary to provide the requisite lighting. For Events 2A and 3, the vertical plane between cameras 1 and 3 should be perpendicular to the direction of shock propagation. All equipment must be placed in the structure and ready for operation no later than T-7 days as access will not be available beyond this time. A grid of alternating 6" black and white squares will be painted inside the structure. This grid will extend two feet up into the LER and three feet down into the LT.

4. RESPONSIBILITIES

a. AFWL will provide and place all necessary photo markers in the overburden and provide or establish a photo reference.

b. AFWL will provide:

- 1) Switch closure with desired timing for camera start and lighting.
- 2) Power as required for cameras and lighting.
- 3) Supplies such as film and extra four lead cable.
- 4) Guidelines for equipment placement and cable routing inside the LER.
- 5) Fuel and maintenance for generators.
- 6) Vehicle support

c. AFSWC/FTT will provide:

- 1) Cameras, timing generators and lighting as required.
- 2) Switch closure cable and relays as required to start cameras and lights.
- 3) Placement of cameras, relays and switch closure cable.
- 4) Heat as required for any photo equipment.
- 5) Manpower necessary to operate generators providing power to cameras.

APPENDIX G  
ENVIRONMENTAL EFFECTS MONITORING

The area local to the HARD PAN I test sites will be monitored to establish the level of explosive effects and to assist in determining the validity of damage claims.

1. HARD PAN I-1 ENVIRONMENTAL MONITORING PROGRAM

The first test in the series is the smallest event. Although no adverse environmental effects are anticipated, test documentation will include monitoring overpressure, ground motion, structural integrity of local wells and occupied dwellings, and conducting an ecological survey of the area.

1) Test event ground motion will be monitored with a minimum of six three-component accelograph stations along radials directed north and east toward the nearest dwellings.

2) Close-in airblast will be measured with overpressure gages at each of the above accelograph stations. Distant overpressures will be recorded at microbarograph stations at the nearest houses and communities.

3) All items of general interest in the town of Trading Post will be inspected and photographed.

4) Detailed inspection and photographic documentation will be accomplished on the four closest inhabited dwellings.

5) Water well inventories will be performed on all active wells within a 2 mile radius. Pre and post shot water quality samples will be taken.

6) An Air Force ecologist will be on site to conduct a pre and post shot survey to detect any major changes in the local ecology.

7) An Air Force meteorologist will be on site to record local weather conditions and monitor forecast predictions. The test will be postponed if any signs of atmospheric inversion, high winds, or major fronts indicate the possibility of anomalous propagation of air pressure effects. See Appendix W for additional details.

2. HARD PAN I-2A ENVIRONMENTAL MONITORING PROGRAM

Since the second event has a larger amount of explosive the environmental monitoring program will be more extensive.

1) Test event ground motion will be monitored with a minimum of eleven three-component accelograph ground stations along three radials: (a) a radial in line with the detonation direction, (b) a northwest radial oriented between the town of Trading Post and the nearest house to the north, and (c) an eastward radial toward the nearest dwelling.

2) Close in airblast will be measured with overpressure gages at most of the above ground motion stations.

3) Far field overpressure will be measured with microbarograph gages at the two nearest dwellings and the towns of Trading Post, Pleasanton, and Amoret.

4) Pre and post shot water level, water quality, and structural integrity will be determined on each active well within a two mile radius.

5) Four boreholes will be instrumented to monitor hydrostatic effects in both the upper and lower aquifers.

6) Air Force Meteorologist will be on-site to determine both the surface conditions and the temperature and winds aloft. The test event will not be detonated unless the rawinsonde and pibal measurements confirm that anomalous propagation is not significant. See Appendix N.

7) A preshot bird survey to obtain a quantitative and qualitative estimate of bird populations will be conducted on both the Marais des Cygnes Wildlife Management Area and the 40 acre pond located southeast of the test area.

8) The mammal population in the surrounding area will be observed and if possible, a census will be made of such animals as deer, raccoon, etc.

9) A survey of the 40 acre pond will be conducted to determine if any fish have been affected by the event.

10) Tree lines will be surveyed for damage - i.e., broken branches, etc.

11) A pre and post-shot chemical analysis will be accomplished on the Marais des Cygnes River and the 40 acre pond to determine dissolved oxygen, turbidity, pH factor, and alkalinity.

### 3. HARD PAN I-2B ENVIRONMENTAL MONITORING PROGRAM

The environmental monitoring program for event 2B will be essentially the same as that for event 2A.

### 4. HARD PAN I-3 ENVIRONMENTAL MONITORING PROGRAM

The last event in the series will contain approximately four times the amount of explosive as event 2B. Since the event is not scheduled until December 1975, the environmental monitoring program will not be finalized until the results of the preceding events have been analyzed. No additional environmental effects are anticipated, therefore, present plans call for a similar monitoring program of airblast, ground shock, and aquifer response in addition to surveys of the ecology, weather, and occupied buildings.

APPENDIX H  
TEST ARMING AND FIRING CHECKLIST

## 1. FIRING SYSTEM

The high voltage firing system will be used for this experiment. All arming operations are controlled from a panel inside the control trailer, and the system includes interlocks to assure safe operation and to prevent malfunction.

## 2. CHECKLIST

The following checklist will be used for arming and firing this test:

- a. All lights on high voltage firing system control panel OFF. "Power On" and "Pre-Arm Interlock" key switches and toggle switches to OFF position. Meters read zero.
- b. Remove "Power On" and "Pre-Arm Interlock" switch keys. Keys in possession of arming party.
- c. Disconnect the following from the firing system control unit:
  - (1) High voltage charge & monitor lines
  - (2) Trigger lines
  - (3) Fiducial Lines
- d. Lock all cable terminations resulting from step "c" in lock box. Key in possession of arming party.
- e. Arming party proceeds to field X-unit. Take DC ohmmeter and gap tester.
- f. Unlock X-unit lock box.
- g. Remove X-unit lock box screws & lift off cover.
- h. Perform gap test on the X-unit.
- i. Perform the following steps:
  - (1) Connect DC ohmmeter to X-unit detonator head.
  - (2) Insert bridgewire in one end of a 20' test cable.
  - (3) Connect test cable to X-unit detonator head & note continuity by ohmmeter reading.
  - (4) Remove ohmmeter line from X-unit detonator head.
  - (5) Check high voltage connections and trigger connections in rear of X-unit.
  - (6) Check option plugs in place.

- j. Arming party return to control van. Leave one of party at X-unit lock box to keep area clear of personnel.
- k. Unlock cable lock box.
- l. Make the following connections to the control unit:
  - (1) Trigger lines
  - (2) High voltage charge and monitor lines
  - (3) Fiducial line
- m. Insert "Power On" and "Pre-Arm Interlock" keys in control panel.
- n. Establish communications with man stationed at X-unit lock box.
- o. Turn on "Power On" and "Pre-Arm Interlock" key switches. (Green light comes on.) No indication on "External Trigger Monitor" or "Trigger Out Monitor" meters.
- p. Turn on pre-arm toggle switch. (The high voltage confirm light will come on when the system is fully charged.) No indication on "External Trigger Monitor" or "Trigger Out Monitor" meters.
- q. After the high voltage confirm light comes on, turn on the arm switch. All panels lights on.
- r. Give a ten-second countdown and trigger the system.
- s. All lights on high voltage firing system control panel off.
- t. Remove "Power On" and "Pre-Arm Interlock" keys. Keys in possession of arming party.
- u. Disconnect the following from the control unit:
  - (1) High voltage charge & monitor lines
  - (2) Trigger lines
  - (3) Fiducial line
- v. Lock all cable terminations resulting from step "u" in lock box. Key in possession of arming party.
- w. Notify person stationed at X-unit lock box that the system has been secured.
- x. Proceed to X-unit lock box. If the bridgewire is broken, proceed with step "y". If the bridgewire failed to break, take corrective action, then repeat steps "i" through "x".
- y. Perform the following steps at each X-unit in turn:

- (1) Connect DC ohmmeter to X-unit detonator head.
  - (2) Inspect firing lines for condition.
  - (3) Connect the firing lines to X-unit detonator head & note continuity.
  - (4) Remove ohmmeter line from X-unit detonator head.
  - (5) Check high voltage connections and trigger connections in rear of X-unit.
  - (6) Check option plugs in place.
- z. Replace X-unit lock box cover.
- aa. Arming party clears the area and returns to control van.
- bb. Unlock the cable lock box and make the following connections to the control unit:
- (1) Trigger lines.
  - (2) High voltage charge & monitor lines.
  - (3) Fiducial line.
- cc. Insert "Power On" and "pre-Arm Interlock" keys in control panel.
- dd. Turn on "Power On" and "Pre-Arm Interlock" key switches. (Green light on.) No indication on "External Trigger Monitor" or "Trigger Out Monitor" meters.
- ee. Turn on pre-arm toggle switch (High voltage confirm light comes on when system charged.) No indication on "External Trigger Monitor" or "Trigger Out Monitor" meters.
- ff. Turn on arm toggle switch. All panel lights on. (The system is now fully armed).
- gg. Test event.
- hh. All lights on high voltage firing system control panel OFF. "Power On" and "Pre-Arm Interlock" key switches and toggle switches to OFF position. Meters read zero.
- ii. Remove "Power On" and "Pre-Arm Interlock" switch keys. Keys in possession of arming party.
- jj. Disconnect the following from the firing system control unit:
- (1) High voltage charge & monitor lines.
  - (2) Trigger lines.
  - (3) Fiducial line.
- kk. Lock all cable terminations resulting from step "jj" in lock box. Key in possession of post shot reentry team.

APPENDIX I  
HOLD CONDITIONS AND PROCEDURES

1. TEST CONTROLLER'S HOLD CONDITIONS

- a. Weather conditions that would result in unacceptable airblast propagation or inadequate lighting or unsafe ordnance handling.
- \*b. Unauthorized personnel on the test site.
- \*c. Unauthorized aircraft in area. (T-0:45:00 to T-0)
- d. Loss of communications to participants (T-3:30:00 to T-0:00:20).
- e. Loss of power at any Camera Position prior to T-0:30:00 min.
- \*f. Loss of power or recording equipment malfunction on any instrumentation van prior to T-10 minutes. From T-10 to T-0, Countdown will be held for primary vans (Van 1, Van 3, Van 5, Van 9, Sandia) only.
- \*g. Greater than 5% in malfunctioning channels up to T-3 min. After T-3 min, van personnel will concentrate on tape recorders.
- \*h. Malfunction of any primary tape recorder up to T-0.
- \*i. IRIG malfunction up to T-0.
- \*j. Malfunction of manual calibrate.
- k. Malfunction in the firing system dry runs.
- l. Loss of 1 radial + 1 gage for Sandia airblast measurements. Loss of 2 out of 4 of the microbarograph instruments.
- m. Malfunction of 50% or more of the primary seismic instruments.

\*NOTE: From T-1 min to T-0 all stations will simply break in and say "HOLD" if any condition occurs which warrants a HOLD status.

2. TEST CONTROLLERS HOLD PROCEDURES

a. Hold Procedure 1

If a Hold is required from T-4:30:00 to T-0:45:00, proceed as follows:

- (1) Continue countdown to T-0:45:00. Then hold the countdown until the problem is resolved.
- (2) Resume the count from the Hold by saying: "All stations - on my mark, the time will be T-45 min. and counting".

b. Hold Procedure 2

If a Hold is required from T-0:45:00 to T-0:20:00, proceed as follows:

- (1) Hold count and determine problem extent.
- (2) Instruct Ordnance to institute Ordnance HP-2 procedures.
- (3) Helicopter:
  - 1) Problem greater than 10 min - Await clearance to land.
  - 2) Problem less than 10 min - Hold position.
- (4) Announce Hold condition over Base Station and to all stations.
- (5) Resolve problem.
- (6) Reset countdown clock to a time no later than T-0:30:00 (may be earlier).
- (7) Resume the count at time set in sequencer by saying: "All stations - on my mark, the time will be T-\_\_\_\_\_ min and counting".

c. Hold Procedure 3

If a Hold is required from T-0:20:00 to T-0:00:00 proceed as follows:

- (1) Hold count.
- (2) Instruct Ordnance to institute Ordnance HP-3 procedures.
- (3) Disable sequence outputs, if applicable.
- (4) Stop all tape recorders.
- (5) Helicopter
  - (a) If problem does not require a dry run or is not in the firing system, notify copter to hold position as long as possible. Offload at Butler if it is necessary to leave.
  - (b) If the problem is related to the firing system, and requires a dry run, notify copter to await clearance to land and refuel, if possible.
- (6) Announce Hold condition over Base Station and to all Stations.
- (7) Reload all tape recorders, if applicable.
- (8) Resolve the problem.
- (9) Assure Ordnance HP-3 procedures complete.
- (10) Reset Countdown clock to time no later than T-0:30:00 (may be earlier).

(11) Resume the count at the time set in the sequencer by saying: "All stations - on my mark, the time will be T- min and counting".

3. VAN HOLD CONDITIONS

- a. Loss of Power to Van Instrumentation System prior to T-0.
- b. Loss of equipment air conditioning power or equipment air conditioning malfunction prior to T-15 minutes.
- c. Malfunction of any tape recorder up to T-0.
- d. Loss of or malfunction of IRIG "A" timing signal to recorders up to T-0.
- e. Malfunction of auto function drawer up to T-0. (includes manual calibration)
- f. Loss of Communications
- g. Greater than 5% malfunctioning channels up to T-3 min. (After T-3 min van personnel will concentrate on tape recorders)
- h. Malfunction of Technical Cameras up to T-3 min.

4. VAN HOLD PROCEDURES

a. Hold Procedure 1

If a hold condition occurs from T-4:30:00 to T-0:45:00, proceed as follows:

- (1) Inform the Test Conductor that a hold condition has occurred-- explain the nature of the condition and an estimate of time required to resolve the problem.
- (2) Inform the Test Conductor as to the amount of time required to continue to T-0 after the problem has been corrected.
- (3) Receive instructions from Test Conductor.

b. Hold Procedure 2

If a hold is required from T-0:45:00 to T-00:05:00, proceed as follows:

- (1) Inform the Test Conductor that a hold condition has occurred-- explain the nature of the condition and an estimate of the time required to resolve the problem.
- (2) Inform the Test Conductor as to the amount of time required to continue to T-0 after the problem has been corrected.
- (3) Determine if manual calibrations (on tape at T-00:50:00) will be valid after the problem has been corrected. Inform the Test Conductor if tape recorders must be reloaded and a new set of manual cals is required.
- (4) Receive instructions from Test Conductor

c. Hold Procedure 3.

If a hold is required from T-00:05:00 to T+00:00:00, proceed as follows:

- (1) Inform Test Conductor that a hold condition has occurred.
- (2) Push the "HOLD" button on the countdown clock.
- (3) "Disable" outputs of the automatic function drawer.
- (4) If tape recorders are running, (T-00:02:00 to T-0) stop tape recorders manually.
- (5) Explain the nature of the condition, give an estimate of the time required to resolve the problem, and the amount of the time required to continue to T-0 after the problem has been corrected.
- (6) Receive instructions from Test Conductor.

5. FIRING SYSTEM HOLD PROCEDURES

a. Hold Procedure 1

If the problem occurs in the firing/detonation system between T-04:30:00 and T-00:45:00, continue working to resolve the problem. Notify the Test Conductor and Safety of the difficulties and advise him that it will be necessary to hold the count at T-00:45:00 unless the problem is resolved beforehand.

b. Hold Procedure 2

- (1) Non-firing/detonation system problems estimated to take less than 10 minutes repair time require no action on part of ordnance.
- (2) If non-ordnance system problem is estimated to take 10 minutes or more to resolve, the EOD chief will obtain all arming system keys. On approval from the Test Conductor, he will quickly proceed to disconnect the x-unit of all firing lines and notify the TCC. Upon notification that the problem has been resolved, the countdown will be resumed at T-00:35:00 with the copter liftoff and x-unit hookup.
- (3) If the problem is related to the firing/detonation system, the EOD chief will obtain all arming system keys. On approval from the Test Conductor and Safety, he will proceed to disconnect the x-unit and short the ends of the firing lines. He will resolve the problem including any required dry runs. Once the problem is corrected, the countdown will be resumed at T-00:35:00 with the copter liftoff and the x-unit hook up.

c. Hold Procedure 3

(1) Check/turn off arm switches, check/turn off pre-arm switches, check/turn off all control panel interlock keys and remove the keys from the control panels. Remove the TCC master key from the TCC control panel. If the problem is not in the firing system, hold until the problem is resolved. Resume the count at T-00:20:00 once the problem is solved.

(2) If the problem is with the firing system, disconnect all connectors from the firing system connector panel. If the problem does not require a dry run, it will be necessary to assure that the system is in its pre T-00:20:00 condition. Resume the countdown sequence at T-00:20:00 once the problem is resolved. If a dry run is required, the connectors just removed shall be locked in the ICC cable lock box. All keys will be given to the arming party who will proceed to the x-unit on approval from the Test Conductor and Safety. All firing lines shall be shorted. Dry runs shall be performed in conformance with proper procedures, as necessary. The system will be restored once the copter has lifted off and the countdown shall be resumed at T-00:30:00.

APPENDIX J  
MISFIRE PROCEDURES

1. TEST CONTROLLER'S MISFIRE PROCEDURE

If a misfire occurs the Test Controller is to:

- a. Direct the Ordnance Engineer to proceed with the disarming of the firing system in accordance with ordnance misfire procedure.
- b. Direct all personnel in all instrumentation vans to remain in their vans and standby for further instructions.
- c. Notify security to maintain preshot positions and standby for further instructions.
- d. After a thirty minute wait, the ordnance re-entry team will convene at the Test Control van in preparation for re-entry to the test bed area.
- e. Maintain contact on the COMMUNICATIONS NETWORK with all stations for follow-up instructions to all stations.

2. ORDNANCE SYSTEM MISFIRE PROCEDURES

- a. Turn off arm toggle switches.
- b. Turn off pre-arm toggle switches.
- c. Turn all control panel keys and ordnance enable key to "OFF" position. Keys in possession of arming party.
- d. All control panel meters read zero.
- e. Disconnect the following from the connector panel:
  1. High voltage charge and monitor lines
  2. Trigger lines
  3. Fiducial input lines
- f. Lock all cable terminations resulting from Step 2e in lock box. Key in possession of arming party.
- g. After waiting for a period of at least thirty minutes, and at the decision of the safety officer, a team consisting of EOD experts, safety officer, ordnance engineer, and ordnance technician will re-enter the test bed area to analyze the situation. No others will be authorized to enter the test bed area.

**THIS REPORT HAS BEEN DELIMITED  
AND CLEARED FOR PUBLIC RELEASE  
UNDER DOD DIRECTIVE 5200.20 AND  
NO RESTRICTIONS ARE IMPOSED UPON  
ITS USE AND DISCLOSURE.**

**DISTRIBUTION STATEMENT A**

**APPROVED FOR PUBLIC RELEASE,  
DISTRIBUTION UNLIMITED.**

APPENDIX K  
DATA REDUCTION AND ANALYSIS

1. RECORD DATA

Primary data recording for all HARD PAN I test events will be magnetic tape. The tapes will contain both IRIG A and B time signals as well as a fiducial signal. The recorders will use one inch magnetic tapes on 10 1/2 inch reels to produce fourteen tracks of constant bandwidth recording. Each recording channel will be calibrated prior to each test event and, where possible, immediately following the event. This calibration will consist of voltage substitution, voltage insertion, resistance insertion, shunt calibration, and/or physical stimulation.

After the recording system is completed and ready for test event, but at least 5 days prior to the event, a dry run test tape will be made. The dry run will be with all recording equipment operating in exactly the same manner as on test day. The tapes will contain all the serial time data, all calibration data, and the "null" excitation levels of all gages. Those tapes will be processed in the same manner as the test tapes to gain experience and to identify any problems.

2. QUICK LOOK DATA REDUCTION

After the test event and any post test calibrations have been completed, the test data tapes will be transported to the AFWL (AD) for data processing. Before processing, identical copies (dubs) of the original data tapes will be produced. Oscillographic records will then be made for all the signals recorded. These oscillographic records will be examined: 1) to determine that sufficient data has been obtained to determine test success, and 2) to determine the duration for digitization.

This review of oscillographic records will be used to prepare the quick look report which will be limited to a statement of test completion and a qualitative evaluation of test success and test results.

3. INITIAL DATA PROCESSING

The initial data processing will consist of three steps, each of which will result in more refined and usable data.

The first step in the initial data processing chain will consist of converting the recorded data from analog to digital form, and conversion to engineering form. The analog tapes will be played back on an Ampex FR-1800H magnetic tape reproduce system at a speed of 120 ips using direct reproduce amplifiers with standard equalizers. The output of this tape machine will be inputted to the discriminators which convert the variations in frequency to variations in voltage. This then becomes the input to the analog-to-digital (A/D) converter. The A/D sampling rate requirements for each data channel will depend on the gage frequency response, cable limitations, or analysis requirements, and will be specified in the instrumentation plan.

The second step in this chain begins when the data has been converted to digital form, converted to engineering units and recorded on a magnetic tape in computer compatible format. This tape is then read into the automated data management and processing system (ADMAPS) along with punched cards establishing data channel annotation and calibration information and a master data channel identification system. The ADMAPS will use this information to generate a data master file and directory for use in later data processing and analysis efforts. At the same time as the master file and directory are being generated, ADMAPS will produce plots of all time histories and appropriate integrated time histories.

The data analyst will then review and evaluate the data and determine on a channel by channel basis which if any will require corrections, such as baseline shift, offset correction, drift removal, etc. This determination will be made based on application of physical laws, personal evaluation of data plots and use of the interactive digigraphic system. When the necessary data corrections have been defined, the third step of initial data processing will be performed. That is, each channel to be modified is recalled by ADMAPS, the appropriate modification accomplished (by ADMAPS or the digigraphics system), and the modified data entered into the master file with an annotation describing the modification performed. ADMAPS will then be used to provide plots of all corrected data, at which time the initial data processing will have been completed. The end result of this activity will be a data report containing all test data (raw and corrected) with necessary descriptive information.

#### 4. FINAL DATA PROCESSING AND ANALYSIS

This final phase considers both data processing and analysis because they are intimately interrelated and are performed in an interrelative manner. It is during this phase that the results of prediction calculations are entered into the data master file and/or used in comparative analysis with test data. The processing accomplished on the test and analysis data will include:

- a. scaling, time shift, integrations
- b. filtering and decimation
  - (1) high pass and low pass
  - (2) band pass and band defect
- c. additional detrending
  - (1) least squares
  - (2) direct subtraction
- d. correlation analysis
  - (1) auto correlation
  - (2) cross correlation

e. frequency analysis

- (1) fast Fourier transform
- (2) power spectral density
- (3) shock response spectra
- (4) transfer functions

f. summarizations

- (1) ensemble averaging
- (2) peak envelope
- (3) statistical means and deviations
- (4) tests for significance
- (5) regression analysis

The processing performed will be accomplished in an interrelative manner with data analysis and interpretation with repeated use of the interactive digigraphics system. Processing with ADMAPS will normally be accomplished on a limited number of data channels at any one time because of the uniqueness of each piece of data. The final product of this final data processing phase will be a series of report ready plots and corresponding analysis and evaluation for use in preparation of the final test report.

APPENDIX L  
PRE- AND POST TEST MODEL SURVEY

1. PURPOSE

The purpose of performing a survey to establish the location of various points on the model before and after the test event is to:

- a. Establish net displacement of model with respect to site datum.
- b. Establish relative displacements of model parts with respect to each other.
- c. Determine warping or distortion of model.

2. REFERENCE DATUM

The entire structure shall be referenced to horizontal and vertical control points away from and unaffected by the blast.

3. MEASUREMENT TOLERANCES

- a. Referenced to site datum:

Vertical  $\pm .02'$  (1/4")  
Horizontal  $\pm .04'$  (1/2")

- b. Referenced to other parts of model:

Vertical  $\pm .01'$  (1/8")  
Horizontal  $\pm .01'$  (1/8")

APPENDIX M  
THE BLEST CONCEPT

In order to generate a shock environment similar to that produced by a surface or near surface nuclear burst it is necessary to simulate the nuclear airblast loading on a considerable area of the earth's surface in the vicinity of the specified target point. At the target point the shock environment is that due to the direct airblast loading in the immediate vicinity of the target plus that due to airblast induced shock waves transmitted through the various geologic layers underlying the surface of the earth. Figure M-1 shows the shock fronts in the air and in the underlying strata for a simple two-layered medium. For this illustrative example the height-of-burst (HOB) was taken to be 340 ft and the device yield as 1 MI. It can be seen that the shock front in the lower (hard) layer begins to outrun the shock front in the air at about 2000 ft from detonation ground zero (DGZ). Energy in this lower layer is coupled back into the upper layer and transmitted toward the surface. At the surface the airborne and the ground transmitted shocks arrive simultaneously at about 2300 ft from DGZ.

Any realistic simulation must take into account both the direct airblast loading and the ground transmitted shock. The High Explosive Simulation Technique (HEST) does this by the detonation of high explosive material in a large, but shallow, surcharge covered cavity. The desired simulation is obtained by tailoring the detonation so that the overpressure time histories at the floor of the cavity are a close approximation to those of an actual event. The length of time over which the generated shock environment at a specified target point is a good simulation is a function of the (horizontal) areal extent of the HEST cavity and the underlying geology. Where the geology is characterized by a considerable depth of material having low seismic velocities, an acceptable duration of "edge-free" simulation time can be obtained with a HEST simulator of modest extent. Where the geology is characterized by near surface hard layers with high seismic velocities the situation alters radically. This can be seen in figure M-2 which shows contours of constant simulation duration for the three geologic profiles listed. Here simulation duration is defined to be the time interval between arrival of the direct airblast at the target point and the arrival of transmitted ground shock at the same point from points on the boundary of the loaded surface area.

For 40 msec of simulation time the clay over shale geology of the upper portion of figure M-2 would require that approximately 8000 ft<sup>2</sup> of surface area be explosively loaded. That would correspond to a circle somewhat less than 100 ft in diameter. By way of contrast, the clay over limestone geology of the lower portion of the figure would require that approximately 400,000 ft<sup>2</sup> of area be loaded to obtain the same simulation time. The area (roughly that of an ellipse 850 ft long and 600 ft wide) would be 50 times as large. A HEST simulator of such large dimensions would be prohibitively expensive.

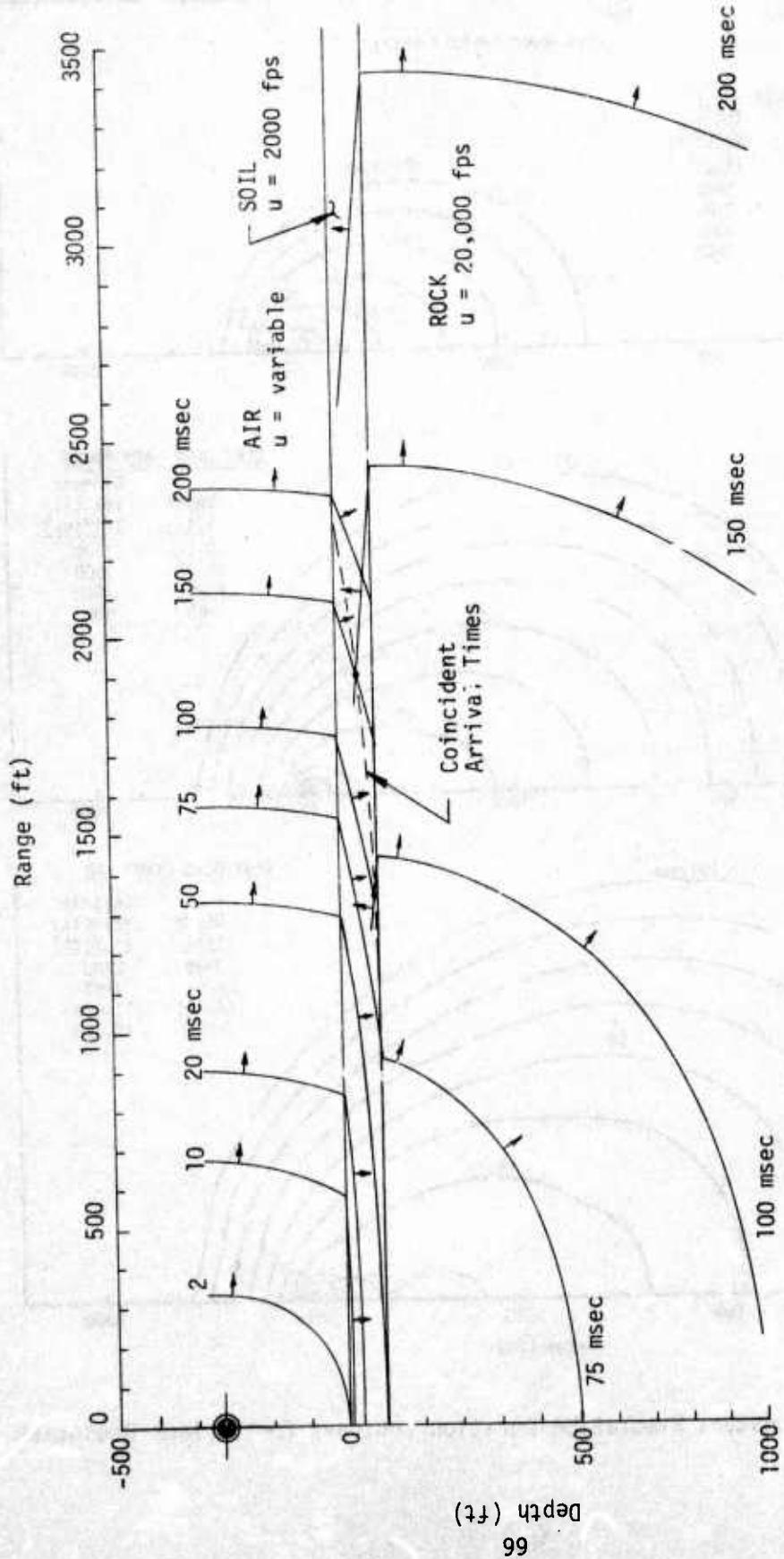

Figure M-1. Outrunning Ground Shock

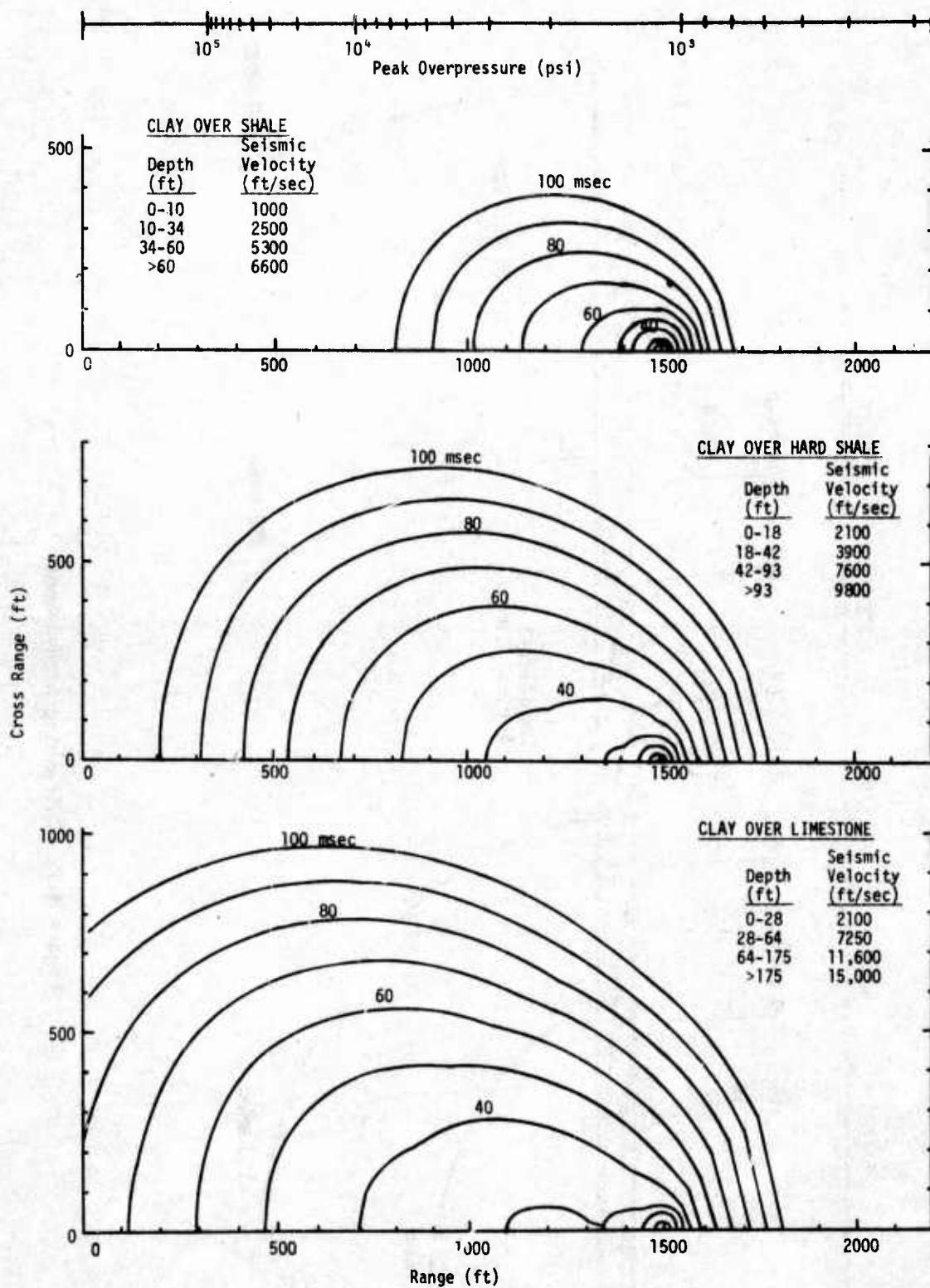

Figure M-2. Constant Simulation Duration Contours for Various Geologies

The Berm Loaded Explosive Simulation Technique (BLEST) is a technique which is an outgrowth of the HEST. Its development was spurred by a requirement to simulate airblast loading of relatively large ground surface areas at lower costs than can be attained with the HEST. The BLEST started as a HEST without a cavity, which eliminated a large part of the construction costs. In the initial investigations of the BLEST, planar arrays of explosives (in the form of sheet explosive or detonating cord) under earthen berms were considered. However, to further reduce costs, later investigations used planar arrays of cylindrical charges in drill holes. This approach was directed toward the use of low cost explosives (e.g., AN/FO). Further, by the use of in-place soil as surcharge, the cost of moving large quantities of soil to construct the overlying berm can be substantially reduced. By properly timing the detonation of the discrete charges the small radius spherical wave fronts can be combined (superimposed) to yield large radius spherical wave fronts, or, over the region of interest, near planar wave fronts.

With BLEST it is not possible to simulate at each point in the loaded area the overpressure function due to airblast from a nuclear detonation. What can be done is to approximate the specific impulse delivered to the ground by the airblast during an interval of time which depends on the location of the point in the BLEST field, the underlying geology, and the desired simulation time. Figure M-3 is a plan view showing the relationship of the target point A, surface ground zero SGZ, and a curve  $\Gamma$  is the locus of those points for which the times of first arrival of the ground borne disturbance at point A are identical. Also shown in the figure are points B, C, and D which are equidistant from SGZ so that the airblast arrives at each of them at the same time. Let

$t_A, t_B, t_C, t_D$  = airblast times of arrival at A, B, C, D

$t_{BA}, t_{CA}, t_{DA}$  = time for shock to travel in earth from B, C, and D to A

$t_s$  = desired duration of simulated environment at point A beyond  $t_A$

$\Gamma$  = locus of points such that  $t_X + t_{XA} = t_A + t_s$   
where X is an arbitrary point on the surface

Figure M-4 shows those portions of the overpressure function incident at B, C, and D which contribute to the shock environment at A during the time period ending at  $t_A + t_s$ . It is the integrals of these truncated overpressure functions which will be taken to be the specific impulses to be delivered at B, C, and C, i.e.,

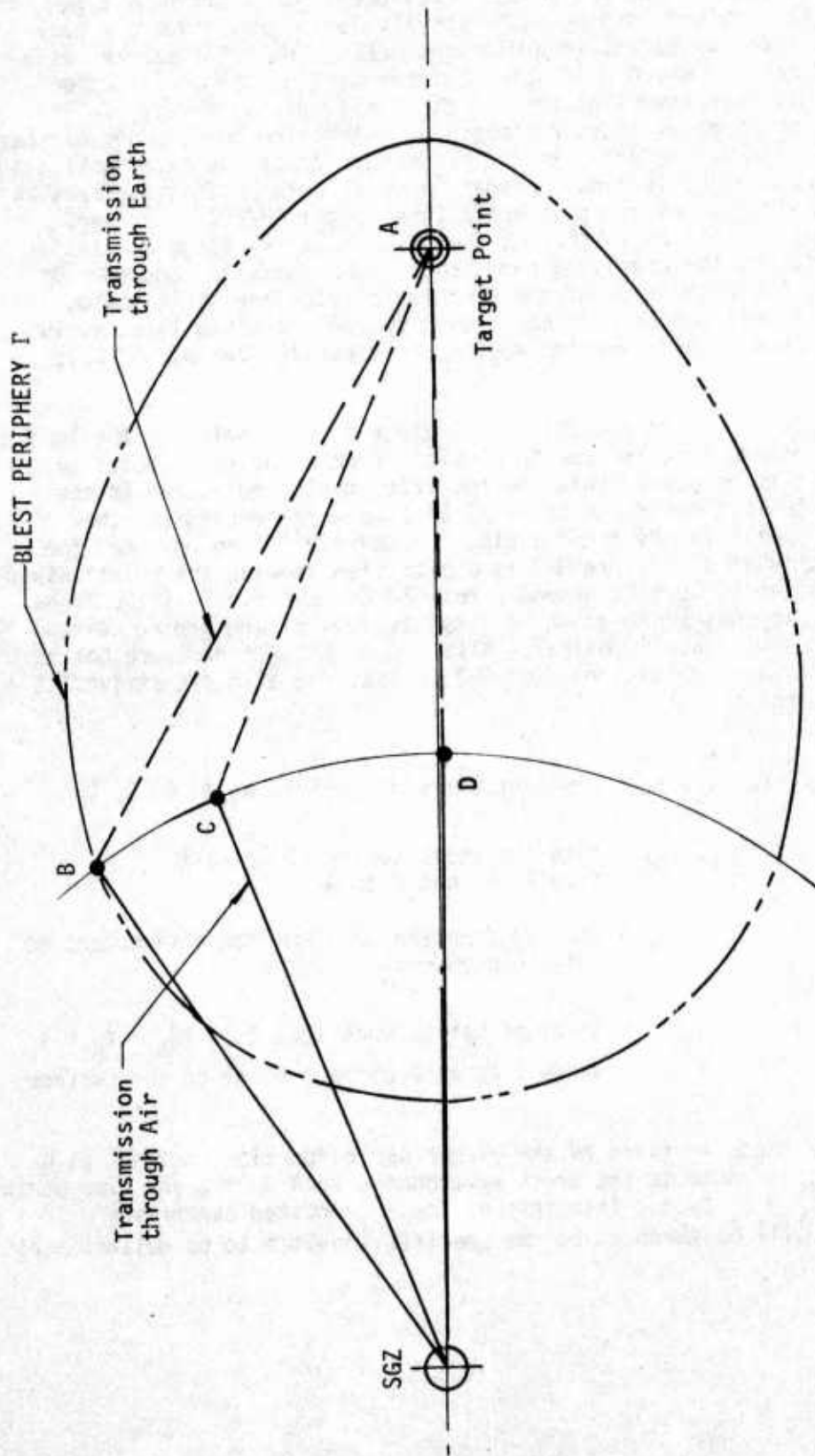

Figure M-3. Shock Travel Paths

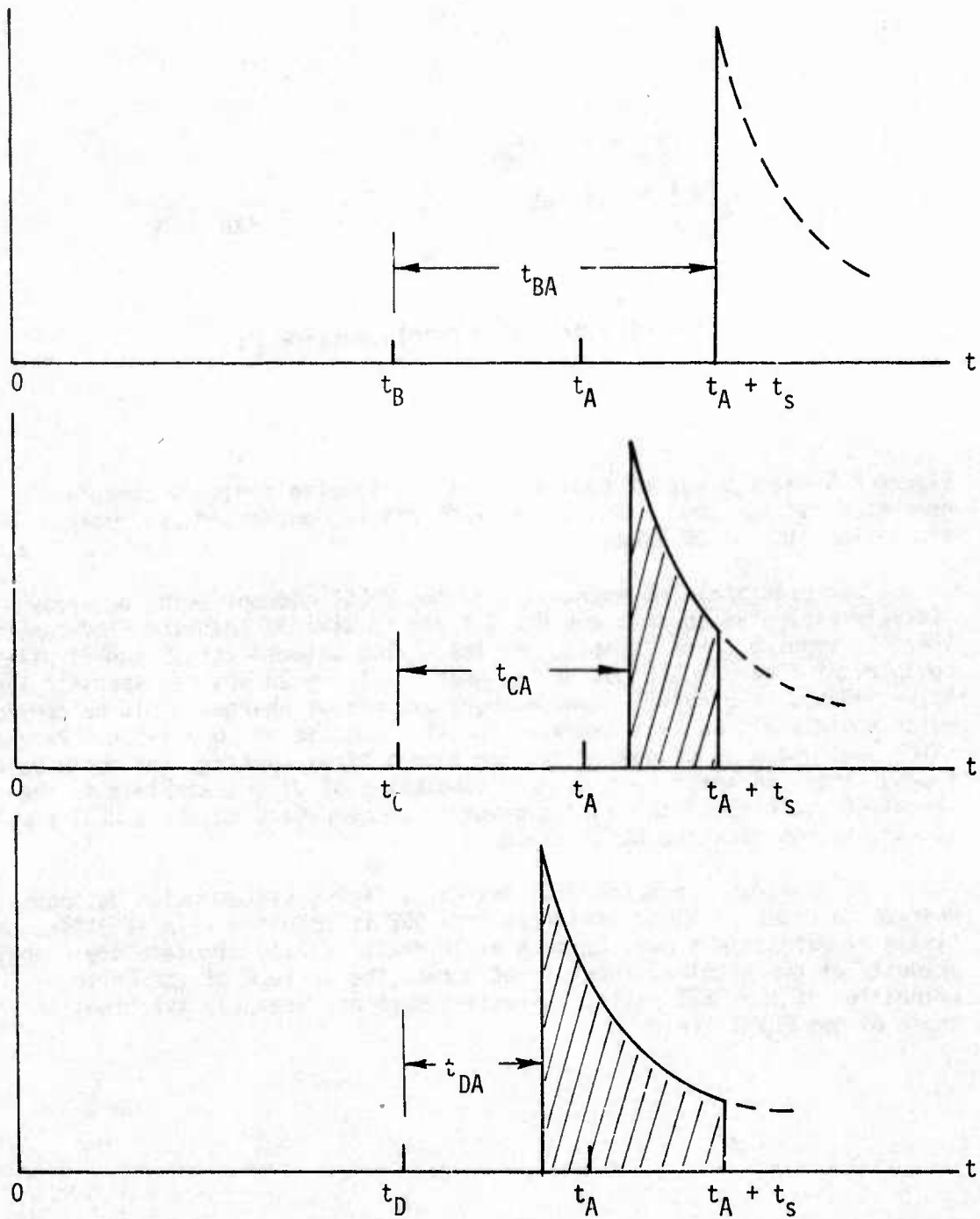

Figure M-4. BLEST Time Relationships

$$I_X = \int_{t_X}^{t_A + t_S - t_{XA}} P(X,t) dt \quad \text{for } t_A + t_S - t_{XA} > t_X$$

$$= 0 \text{ otherwise (for points outside } \Gamma)$$

Figure M-5 shows a set of constant specific impulse contours computer generated for the conditions of the HARD PAN I-3 event and assuming a simulation time of 30 msec.

For practical implementation of the BLEST concept using an array of discrete explosive charges the BLEST field is divided into zones of constant specific impulse. For example, the zone lying between the 19 and 21 psi-sec contours of figure M-5 would be assigned a uniform 20 psi-sec specific impulse value. Based on previous experience, a pattern of charges would be developed which would yield an area averaged specific impulse of 20 psi-sec. Parameters which would have to be determined are charge size, spacing, and depth below the surface. In order to provide a simulation of direct airblast in the immediate vicinity of the target point it is necessary to use a HEST simulator in conjunction with the BLEST field.

To complete the BLEST/HEST design, a firing system which detonates the charges in order of their distances from DGZ is required. In addition, the timing of detonations must be such as to realistically simulate the changing velocity of the airblast shock front across the surface of the earth. Detonation of the HEST cavity explosives must be carefully synchronized with those of the BLEST field.

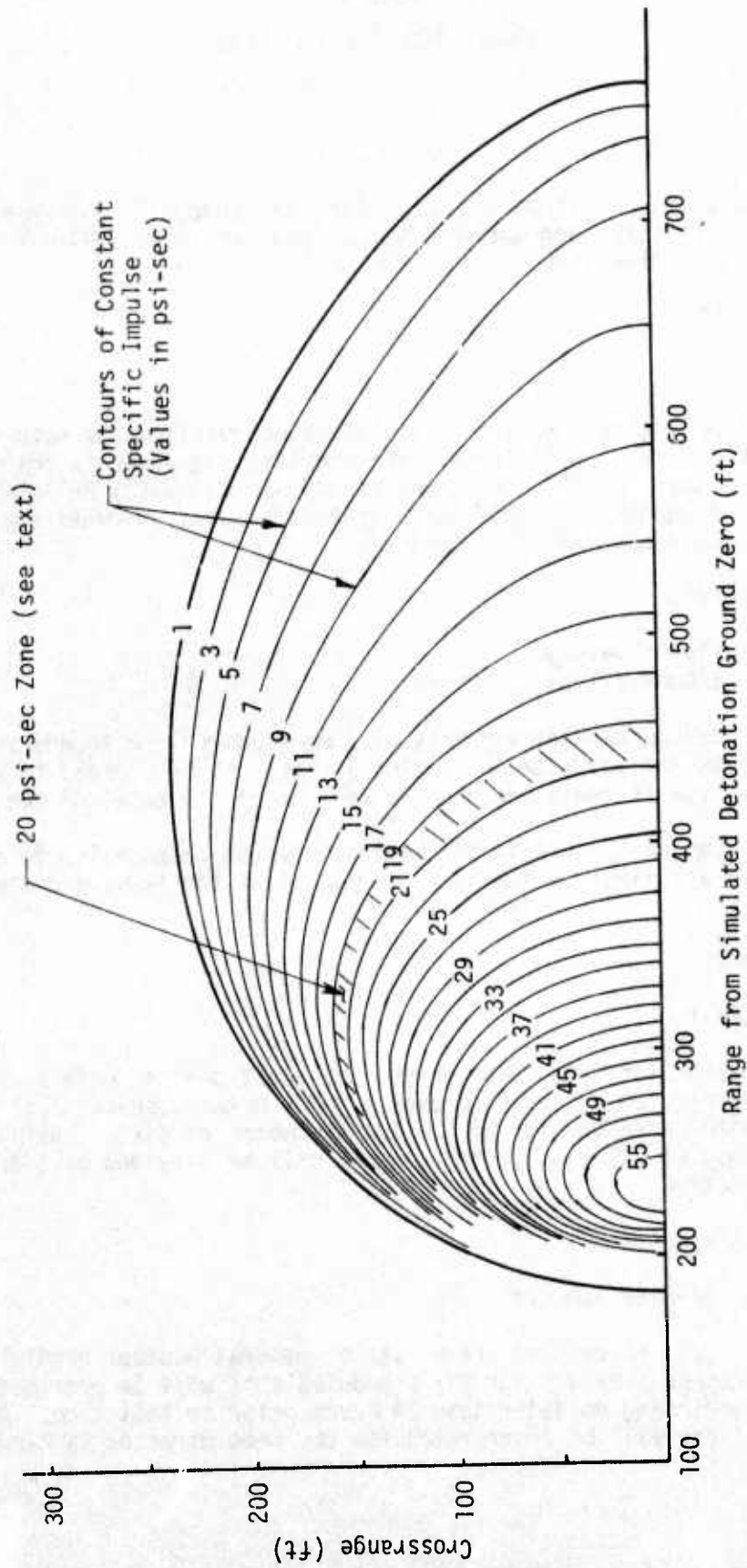

Figure M-5. BLEST Constant Impulse Contours

APPENDIX N  
METEOROLOGICAL SUPPORT PLAN

1. PURPOSE

This Appendix describes the meteorological support requirements, assigns responsibilities and outlines the procedures to be followed in providing meteorological support to HARD PAN I.

2. REQUIREMENTS

a. General

Meteorological support requirements evolve from the nature of the activities inherent in HE tests. The specific requirements come from those general areas: Flight and Ground Safety and Community Relations. The primary areas of concern in these three areas are severe weather conditions and anomalous sound propagation potential.

b. Specific

- 1) Flight Safety
- 2) Ground Safety

Severe weather warnings will be required for thunderstorms and/or surface winds, including gusts, exceeding 35 kts. To be useful, these warnings must arrive on site at least one hour in advance of the onset of the conditions specified.

3) Community Relations: Anomalous sound propagation forecasts will be required for all events which have the potential for causing disturbances off-site.

3. PROCEDURES

a. General

A meteorologist will be on-site at least one day before all major events and for selected calibration events. All meteorological support will be provided and/or arranged for by the on-site meteorologist. During periods when a meteorologist is not on-site, support will be provided by a designated weather organization.

b. Specific

(1) On-Site Support

(a) Forecasts: Forecasts of general weather conditions and vertical sound-speed profiles for the scheduled shot will be provided to the test director beginning no later than 24 hours prior to shot time. All expected conditions will be interpreted for the test director in terms of

the expected impact on the experiments (e.g. lighting conditions, enhancement regions). Hourly updating will be provided beginning at T-4 hours.

(b) Observations: As a minimum, a local winds aloft observations will be made, to be integrated with a selected, representative vertical temperature profile, to produce representative vertical speed of sound profiles for each major event. For selected events, a mobile rawin sonde team will be on site to provide the basic data required. Additional observations will be made as required by the test director and the on site meteorologist.

(2) Other than On Site Support

During periods when a meteorologist is not on-site, arrangements will be made to provide severe weather warnings to on-site personnel.

APPENDIX O  
REPORT REQUIREMENTS

1. GENERAL

Results of the HARD PAN I test series should be evaluated and submitted verbally and in writing to the Test Director as soon as possible after each event. Submittals should be in accordance with the Security Guidance given in Appendix A.

2. EVENT DAY REPORT

Project Officers participating in each event will make a verbal report to the Test Conductor and in turn to the Test Director within 4 hours after the event. The report will indicate the apparent success of the experiment, functioning of recording equipment and cameras, approximate crater dimensions, etc.

3. QUICK-LOOK DATA REPORT

Quick-Look Data reports will be required for each major event. The purpose of the Quick-Look Data Report is to provide the funding agencies with a preliminary report of individual test results so that a rational appraisal can be made to determine if the test program objectives are being met. Quick-Look Data reports will be a compilation of results or measurements from HARD PAN I Events 1, 2A, 2B, and 3 with the degree of analysis which can be accomplished in the available time. The Quick-Look Data report is not intended for distribution outside of AFWL and the primary agencies participating in the HARD PAN I events. The Quick-Look Data report will be required within 30 days after each event, and will be prepared in AFWL Technical Note (TN) format.

4. DATA REPORT

A data report for each event will be required and will be a compilation of the background, the test objectives, a description of the test to include the test site and geologic/seismic profile, the requirements for instrumentation, data analysis, data plots, results, summary, and conclusions and/or recommendations for each event. The data report is not intended for distribution outside of AFWL and the agencies participating in the HARD PAN I events. The data reports will be prepared in TN format.

5. FINAL REPORT

A final report will be prepared that will include all events. This report will be prepared from the Quick-Look Data reports and final data reports, and will be submitted for publication within 120 days after HARD PAN I, Event 3. Dissemination of the final report will be in accordance with the distribution list provided by the AFWL.

The purpose of the final report is to present data from the experiments, to draw conclusions regarding the consistency and reliability of the data, to evaluate the performance of the instrumentation, and to present recommendations for the most effective use of the data. Effective use of the results of these experiments require their integration with other programs to provide a better understanding of outrunning ground shock and structure-medium interaction. The final report should not, therefore, be a complete treatment of the subject, but a documentation of results with reasonable conclusions as to accuracy, potential usefulness, and limitations.

6. TEST CONDUCTOR'S REPORT

The test conductor's report will be submitted within 90 days of the completion of HARD PAN I, Event 3, and will cover all aspects of construction, test site operations, organization and scheduling of events, and participants.

DISTRIBUTION LIST

DEPARTMENT OF DEFENSE

DDC  
2 cy ATTN: TC

Dir.  
DNA  
3 cy ATTN: SPSS

DDR&F  
2 cy ATTN: Asst. Dir., Strat. Wpns.

JSTPS  
ATTN: JLTW

DEPARTMENT OF THE AIR FORCE

AFSC  
2 cy ATTN: DOB

AFWL  
ATTN: HO, Dr. Minge  
ATTN: DEV, Capt McGrath  
2 cy ATTN: SUL  
5 cy ATTN: DEX  
20 cy ATTN: DEV

CINCSAC  
ATTN: DEE  
4 cy ATTN: XPQT

HQUSAF  
ATTN: PREE  
2 cy ATTN: RDQS

DEPARTMENT OF THE AIR FORCE

SAMSO  
ATTN: Library  
5 cy ATTN: MNNH, Capt Kaiser

DEPARTMENT OF DEFENSE CONTRACTORS

CERF  
2 cy

Civ. Nuc. Sys.  
ATTN: Dr. Crawford

General Electric Co.  
TEMPO-Center for Advanced Studies  
ATTN: Dr. Doran

TRW Systems Group  
ATTN: Technical Library  
2 cy ATTN: Dr. Farrell, R1/2178