

UNCLASSIFIED

AD NUMBER

ADB023254

LIMITATION CHANGES

TO:

Approved for public release; distribution is unlimited.

FROM:

Distribution authorized to U.S. Gov't. agencies only; Test and Evaluation; JUL 1975. Other requests shall be referred to Army Natick Development Center, MA 01760.

AUTHORITY

NATICK ltr 21 Aug 1978

THIS PAGE IS UNCLASSIFIED

**THIS REPORT HAS BEEN DELIMITED
AND CLEARED FOR PUBLIC RELEASE
UNDER DOD DIRECTIVE 5200.20 AND
NO RESTRICTIONS ARE IMPOSED UPON
ITS USE AND DISCLOSURE.**

DISTRIBUTION STATEMENT A

**APPROVED FOR PUBLIC RELEASE;
DISTRIBUTION UNLIMITED.**

AD-B023254-L

AFFTC-TR-75-22

1

Feasibility Investigation of a Two-Stage, Platform-Mounted Airdrop System



JULY 1975

**DISTRIBUTION LIMITED TO U.S. GOVERNMENT AGENCIES ONLY
(TEST AND EVALUATION), JULY 1975. OTHER REQUESTS FOR
THIS DOCUMENT MUST BE REFERRED TO U.S. ARMY
NATICK DEVELOPMENT CENTER (ANXNM-UE),
NATICK, MASS 01760
CONTROLLING OFFICE: U.S. ARMY
NATICK DEVELOPMENT CENTER, (ANXNM-UE)**

**AIR FORCE FLIGHT TEST CENTER
EDWARDS AIR FORCE BASE, CALIFORNIA
AIR FORCE SYSTEMS COMMAND
UNITED STATES AIR FORCE**

D D C
1
D

This technical report was submitted under Job Order Number 921C40 by the Deputy Commander for Operations of the Air Force Flight Test Center, Edwards AFB, California 93523.

Foreign announcement and dissemination by the Defense Documentation Center are not authorized because of technology restrictions of the U.S. Export Control Acts as implemented by AFR 400-10.

Prepared by:

John Krizauskas

JOHN KRIZAUSKAS, Capt, USAF
Project Engineer

This report has been reviewed and is approved for publication:

James W. Wood

JAMES W. WOOD
Colonel, USAF
Deputy Commander for Operations

Robert A. Ruseworth

ROBERT A. RUSEWORTH
Brigadier General, USAF
Commander

Qualified requesters may obtain copies of this report from the Defense Documentation Center, Cameron Station, Alexandria, Virginia 22314. Department of Defense contractors must be established for DDC Services, or have "need to know" certified by cognizant military agency of their project or contract.

DDC release to NTIS is not authorized.

When U.S. Government drawings, specifications, or other data are used for any purpose other than a definitely related government procurement operation, the government thereby incurs no responsibility nor any obligation whatsoever; and the fact that the government may have formulated, furnished, or in any way supplied the said drawings, specifications, or any other data is not to be regarded by implication or otherwise, as in any manner licensing the holder or any other person or corporation or conveying any rights or permission to manufacture, use, or sell any patented invention that may in any way be related thereto.

Do not return this copy; retain or destroy.

UNCLASSIFIED

SECURITY CLASSIFICATION OF THIS PAGE(When Data Entered)

(Block #20, continued)

obtained on all tests. Selected forces on components in the test system were measured on all but one test. The most significant problem encountered during this program was test load oscillation during first stage descent. Recommendations are made on methods employed to reduce test load oscillation.



UNCLASSIFIED

SECURITY CLASSIFICATION OF THIS PAGE(When Data Entered)

PREFACE

The testing reported herein was requested by U.S. Army Natick Development Center, Airdrop Engineering Laboratory, Natick, Massachusetts in a letter dated 15 March 1974. This test program was authorized by Air Force Flight Test Center (AFFTC) Project Directive No. 74-98A and documented as Job Order Number 921C40. Testing began 29 July 1974 and was completed on 23 April 1975. This report constitutes closing action on this program.

TABLE OF CONTENTS

	Page No.
INTRODUCTION	5
Background	5
Purpose	5
Scope	5
TEST ITEM	5
Extraction/Stabilization Parachute Subsystem	6
Recovery Parachute Subsystem	7
TEST SUPPORT EQUIPMENT	7
Aircraft	7
Test Loads	7
Loading Equipment	7
DATA ACQUISITION	9
Test Data	9
Zero Time	9
Space Positioning	9
Telemetric Equipment	9
Photographic Coverage	9
TEST CONDITIONS AND PROCEDURES	9
Test Conditions	9
Parachute Packing Procedures	9
Extraction Force Transfer Device Rigging Procedures	10
Loading Procedures	10
Preflight Procedures	10
Inflight Procedures	10
Post Test Procedures	10
TEST RESULTS	10
CONCLUSIONS AND RECOMMENDATIONS	10
APPENDIX A - Test Item Configuration and Rigging Methods	15
APPENDIX B - Individual Test Results and Test Item Development	29
GLOSSARY OF TERMS	31

Preceding Page BLANK

LIST OF ILLUSTRATIONS

Figure No.	Title	Page No.
1	Two-Stage, Platform-Mounted, Single Recovery Parachute Airdrop System	5
2	Two-Stage, Platform-Mounted, Multiple Recovery Parachute Airdrop System	6
3	35K Force Transfer Device	8
4	Guillotine Knife System Force Transfer Device	8
5	Test Load Oscillation	14
A1	Test Item Configuration I	16
A2	Force Transfer Device Used with Configuration I on Tests No. 1 through 4	17
A3	Force Transfer Device Used with Configuration I on Tests No. 5 and 6	17
A4	Force Transfer Device Used with Configuration I on Tests No. 7 and 8 and with Configuration II on Tests No. 9 through 19	17
A5	Test Item Configuration II	18
A6	Suspension Sling Confluence Point Connection Used with Configuration II on Tests No. 9 and 10	20
A7	Suspension Sling Confluence Point Connection Used with Configuration II on Tests No. 11 through 15	20
A8	Suspension Sling Confluence Point Connection Used with Configuration II on Tests No. 16 and 17	21
A9	Suspension Sling Confluence Point Connection Used with Configuration II on Tests No. 18 and 19	21
A10	Rigging Method A, Used on Test Item Configuration I on Tests No. 1 and 2	22
A11	Rigging Method B, Used on Test Item Configuration I on Tests No. 3 through 8	24
A12	Rigging Method C, Used on Test Item Configuration I, Tests No. 9 through 18	26
A13	Suspension Sling Confluence Point Break Tie Used on Rigging Method C, Tests No. 9 and 10	27
A14	Suspension Sling Confluence Point Break Tie Used on Rigging Method C, Tests No. 11 through 18 and on Rigging Method D, Test No. 19	27
A15	Rigging Method D, Used on Test Item Configuration II, Test No. 19	28

LIST OF TABLES

Table No.	Title	Page No.
1	Single Recovery Parachute System (Configuration I) Test Results	12
2	Multiple Recovery Parachute System (Configuration II) Test Results	13
A1	Test Item Configuration and Rigging Method Matrix	15

INTRODUCTION

BACKGROUND

Experience in Southeast Asia has shown that the standard low altitude method of airdrop exposes the drop aircraft to excessive hazards from enemy ground fire. As a solution to these aerial delivery hazards, the capability to drop loads at high altitude without compromising accuracy of delivery at ground level is being developed. One of the methods under investigation is the two-stage system of dropping aerial delivery loads. The two-stage system allows aircraft to deliver loads from the relative safety of higher altitudes. The load descends from the higher altitudes utilizing a small stabilization parachute. The high rate of descent, during the initial stage, reduces drift. Once the load has reached a lower altitude, the recovery parachute(s) (second stage) is deployed to provide a low rate of descent for safe load recovery. This technique was initially developed using A-22 container loads. This program extends the concept to larger platform-mounted airdrop loads.

PURPOSE

The purpose of this test program was to investigate the feasibility of a two-stage airdrop system for platform-mounted loads. The specific objectives were:

1. To collect data on the behavior and performance of the platform and parachutes during two-stage airdrop. These data were to be collected on a range of load weights using various stabilization parachutes.
2. To determine and define any problems which may occur in this type of airdrop, particularly those associated with the high speed descent and the deployment and opening of the recovery parachutes.
3. To develop and apply control methods, items, and rigging techniques to overcome any problems found with this system.

SCOPE

Nineteen platform airdrop tests were conducted from C-130 aircraft. Tests were conducted at an indicated airspeed of 130 or 150 knots. Tests were initiated at mean sea level (MSL) altitudes ranging from 8,060 to 10,620 feet. The extracted weight of the loads ranged from 2700 to 15,200 pounds. Displacements, velocities, event times, and photographic coverage were obtained on all tests. Selected forces on components in the test system were measured on all but one test.

TEST ITEM

The test item was a high altitude, two-stage, platform-mounted airdrop system (Figures 1 and 2).

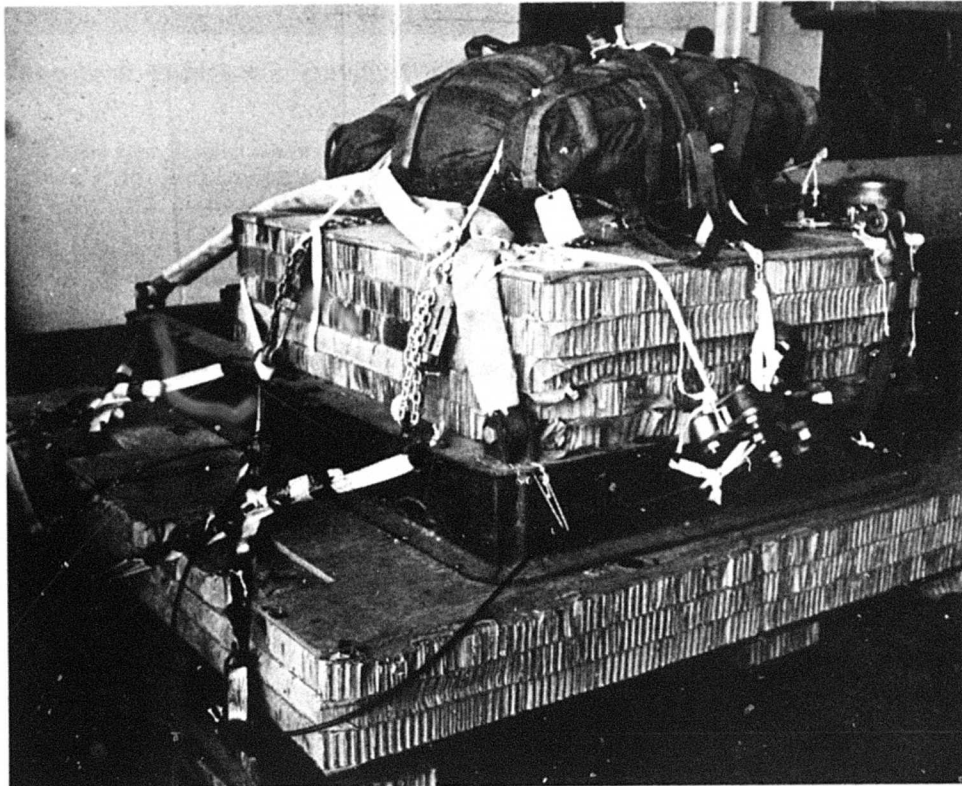

Figure 1. Two-Stage, Platform-Mounted, Single Recovery Parachute Airdrop System.



Figure 2. Two-Stage, Platform-Mounted, Multiple Recovery Parachute Airdrop System.

Two test item configurations were tested. A detailed component listing and rigging schematic for each test item configuration are presented in Appendix A. The major components of this system were an extraction/stabilization parachute, one or three recovery parachutes, and associated textile and hardware items. A description of the components and their functions follows.

EXTRACTION/STABILIZATION PARACHUTE SUBSYSTEM

Description

The extraction/stabilization parachute subsystem consisted of either a 15-, 22-, or 28-foot nominal diameter (D_0) ringslot (RS) parachute; an extraction/stabilization parachute deployment bag; either a 148-, 260-, 294- or 432-inch reefing line; and a 60-foot extraction line of either 2- or 8-ply Type X nylon webbing and associated connecting webbing and hardware. The 148- and 260-inch reefing lines were locally fabricated in accordance with Air Force T.O. 13C5-2-1. Installed lengths were 144 and 256 inches respectively. The 294- and 432-inch reefing lines were locally fabricated in accordance with 6511th Test Squadron Drawing No. 62D4368 with the following exceptions:

1. The reefing lines were fabricated from 4000-pound breaking strength tubular nylon webbing (FSN 8305-082-5753). On the 294-inch line, there were 28 loops 10-1/2 inches apart. On the 432-inch line, there were 36 loops 12 inches apart.
2. The ends of the reefing lines were fabricated so that a 1-inch connector link (P/N 101735) could be used to connect the ends of each line together.

Function

Following deployment and inflation of the extraction/stabilization parachute, the load was extracted from the aircraft. The load was stabilized by the extraction/stabilization parachute during initial descent for either 30 or 40 seconds. At force transfer, the extraction/stabilization parachute was released from the load, thus deploying the second stage recovery parachute(s).

RECOVERY PARACHUTE SUBSYSTEM

Description

The recovery parachute subsystem consisted of either one or three 100-foot D₀ G-11A recovery parachutes, each modified by the addition of a 95-foot vent pulldown line; either one or three G-11A deployment bags; either a 20-, 30-, or 40-foot reefing line with either 2- or 4-second time delay cutters; either one 20-foot or three 40-foot 6-ply Type X nylon riser extensions; either a 2- or 8-ply Type XXVI nylon webbing deployment line; either 2 or 4 release knives; parachute restraint ties of either 1-inch wide 4000- or 6000-pound nylon webbing; an open-link safety clevis (go-no-go); and associated connecting webbing and hardware.

Function

During extraction of the load from the aircraft, the open link safety clevis was closed by a static line in the aircraft. Upon transfer of the extraction/stabilization parachute force, the parachute restraint ties were cut by the release knives which were activated by the deployment line. The G-11A parachute(s) was then deployed by the extraction/stabilization parachute. As the parachute skirt was deployed from the deployment bag, the time-delay reefing line cutters were armed. The recovery parachute(s) was initially deployed in the reefed condition. After the reefing line was cut (2 or 4 seconds), the recovery parachute(s) inflated to a full open condition.

TEST SUPPORT EQUIPMENT

AIRCRAFT

C-130 aircraft equipped with either A/A 32H-4 or A/A 32H-4A Aerial Unloading Kits were used as the drop aircraft on all tests.

TEST LOADS

Load-Bearing Platforms

U.S. Army, Type II modular platforms assembled from two side rails with indents and two or three panels were used on all tests. These platforms when assembled were 8 or 12 feet long and 9 feet wide.

Weight-Test Platforms

Weight-test platforms were used as test loads on all tests. These platforms were either 8 or 12 feet long. Platform weight and center of gravity was adjusted using 250- or 500-pound steel ballast blocks.

Paper Honeycomb Material

Layers of paper honeycomb material were used between the weight-test and load-bearing plat-

forms for energy dissipation at ground impact. The paper honeycomb was also used to construct the silhouette required to give the desired projected frontal area of the test load.

Platform Restraint Straps and Devices

Standard tiedown straps, chains, and tensioning devices were used to restrain the weight-test platforms to the load-bearing platforms. Sufficient tiedowns were used to provide a minimum restraint of 4 g's forward and 2 g's in the vertical, lateral, and aft directions.

Load Suspension Slings

Suspension slings were used to suspend the weight-test platform from the recovery parachute subsystem. The slings were made in either one or two pieces. The one-piece slings were 10 feet long and the two-piece slings were composed of a 3-foot length and either a 6-foot 6-inch, 10-foot, or 12-foot length. The two pieces were connected by either a G-11 clevis or a strain link with connector plates. All slings were covered with salvaged 2-1/2-inch or 6-inch fire hose.

Force Transfer Device

A force transfer device was used to release the extraction/stabilization parachute from the load. The force transfer device was either a 35K force transfer device (Figure 3) or a gullotine knife system (Figure 4). Both items were modified to be activated by a CBS cutter which cut a shear web.

Confined Ballistic System (CBS) Cutter

A CBS cutter manufactured by Teledyne Aerospace Systems, Inc. was used to initiate the force transfer device. The CBS cutter used was a time-delayed, confined ballistic cutter. The time delays selected for use were 30 and 40 seconds. The CBS cutter was armed by an arming lanyard connected to a D-ring on the floor of the aircraft. After a pre-set time delay, a shear web was cut allowing activation of the force transfer device.

LOADING EQUIPMENT

Fork Lift

A 10,000-pound-capacity fork lift was used to transport test loads from the rigging area to the aircraft and to place the loads aboard the aircraft. The fork lift was also used to load ballast weights into the weight-test platforms.

Aircraft Loading and Unloading Truck

An A/S32H-5 aircraft loading truck (commonly referred to as a 25K loader) was used to transport test loads from the rigging area to the aircraft and to place the loads aboard the aircraft.

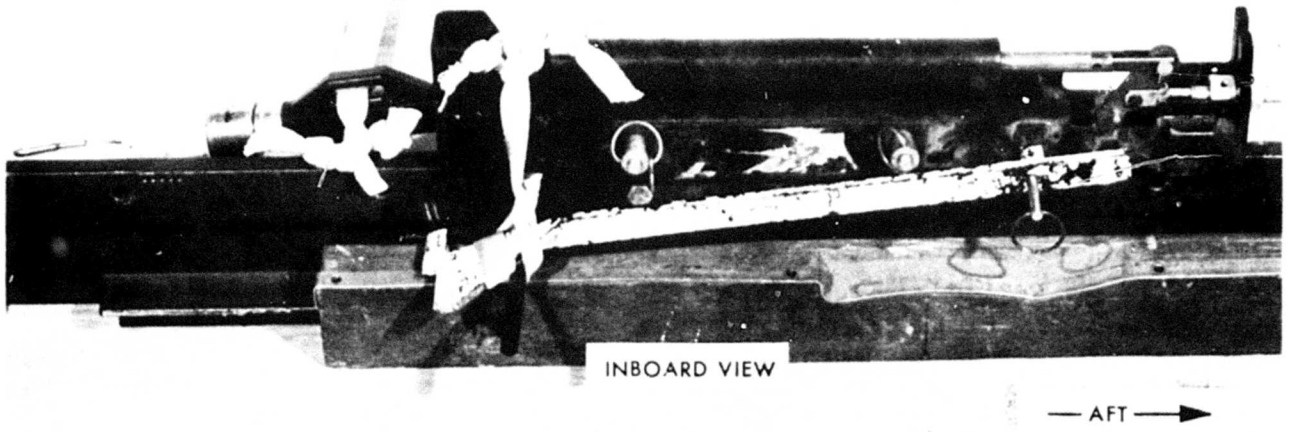

Figure 3. 35K Force Transfer Device (Actuator Only Shown).

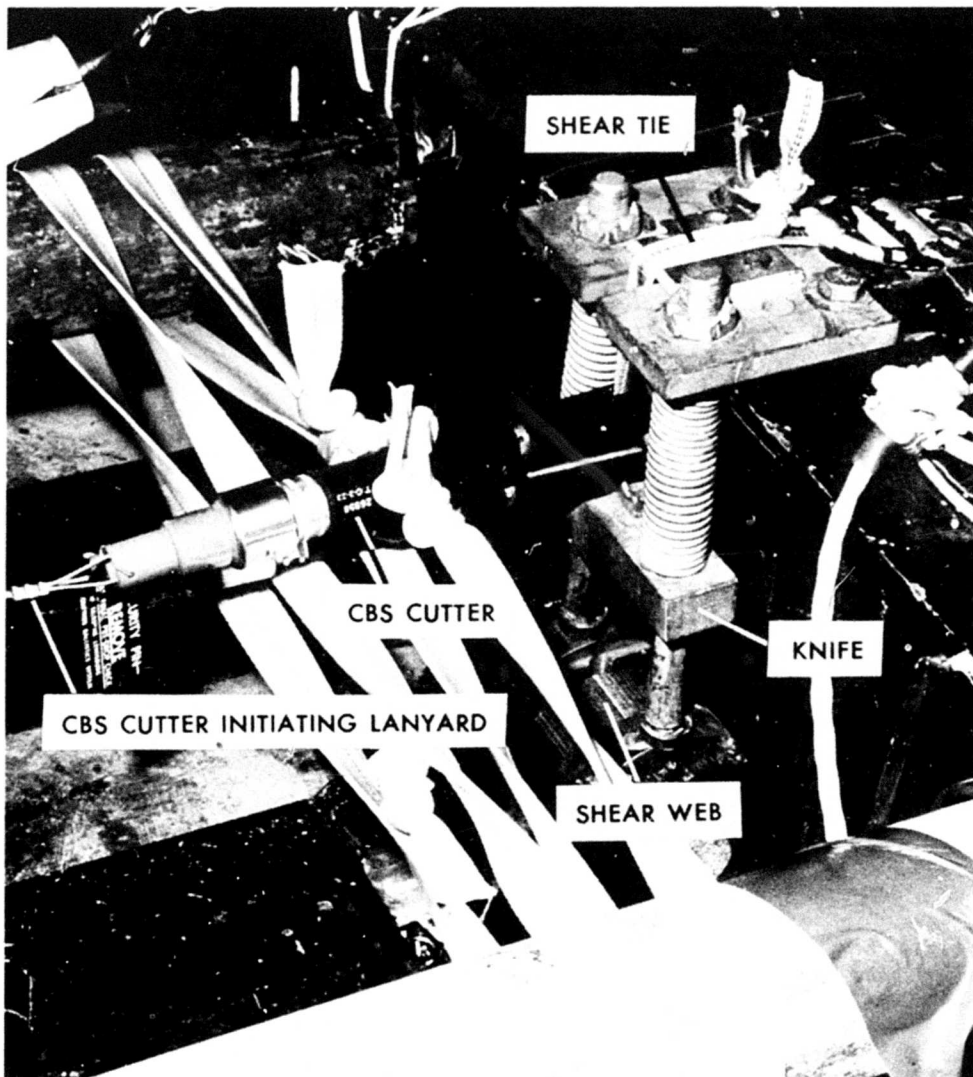

Figure 4. Guillotine Knife System Force Transfer Device.

Crane

A 65-ton-capacity truck-mounted crane was used to position test loads on the aircraft loading and unloading truck. The crane was also used to unload test loads from the recovery vehicles after drop.

DATA ACQUISITION

TEST DATA

Test data were acquired using electronic and optical methods and were recorded on 100 Hz binary coded time bases.

ZERO TIME

Zero time was determined by either a UHF signal, which was transmitted from the aircraft as the CBS cutter activation lanyards were pulled, or by visual observation of the load as it cleared the aircraft ramp.

SPACE POSITIONING

Space positioning data were acquired on all tests. Cinetheodolites were used to determine positions in space of the test loads. From this space positioning data, altitude and velocity were computed and elapsed time tabulations were printed.

TELEMETRIC EQUIPMENT

Telemetric equipment was used to obtain forces and event times. Sensors mounted on the test item fed data to transmitters mounted on the load. The transmitted signals were received at a ground-based receiving station near the drop zone. Signals were recorded on magnetic tape for subsequent playback and printout on oscillograms. The oscillograms were annotated with the values of various parameters at significant times, using calibration signals received just prior to the initiation of a test.

PHOTOGRAPHIC COVERAGE

Air-to-air, ground-to-air, and onboard motion picture coverage was obtained using 16mm and 35mm photographic equipment. The film was exposed at speeds ranging from 24 to 200 frames per second. Common binary coded timing marks on cinetheodolite or ground-to-air motion picture film were used to determine event times. Air-to-air coverage was obtained on five tests using a T-28 aircraft.

On selected tests, ground-to-air 70mm sequence still photographs were obtained. The motion picture coverage and sequence still photographs were used in making qualitative analyses of system performance. Rigging still photographs were also obtained.

TEST CONDITIONS AND PROCEDURES

TEST CONDITIONS

Single recovery parachute system test load gross weights ranged from 2,700 to 7,870 pounds. These tests were conducted from C-130 aircraft flying at 150 KIAS and at mean sea level altitudes ranging from 8,610 to 10,620 feet.

Multiple recovery parachute system test load gross weights ranged from 4,760 to 15,200 pounds. These tests were conducted from C-130 aircraft flying at 130 or 150 KIAS and at mean sea level altitudes ranging from 8,060 to 10,280 feet.

PARACHUTE PACKING PROCEDURES

Extraction/Stabilization Parachutes

The extraction/stabilization parachutes were packed as follows:

15-foot D₀ RS Parachutes. U.S. Army TM 10-1670-203-23/U.S. Air Force TO 13C5-2-22 was used to pack the 15-foot D₀ RS parachute.

22-foot D₀ RS Parachutes. U.S. Army TM 10-1670-204-25/U.S. Air Force TO 13C5-13-1 was used to pack the 22-foot D₀ RS parachute with one addition. The reefing line was attached after laying out the canopy and just prior to airing and folding. All other packing procedures remained unchanged.

28-foot D₀ RS Parachutes. U.S. Army draft TM AX-SPO-0029, dated October 1972, was used to pack the 28-foot D₀ RS extraction parachutes. When packing the 28-foot D₀ parachute with the 432-inch-long reefing line, the procedures outlined in the above draft TM were used with one addition. The reefing line was attached after laying out the canopy and just prior to airing and folding. All other packing procedures remained unchanged.

Recovery Parachutes

The G-11A cargo recovery parachutes with 95-foot-long centerlines and either 20-, 30-, or 40-foot-long reefing lines were packed in accordance with U.S. Army TM 10-1670-215-23/U.S. Air Force TO 13C5-6-2 with the following additions:

1. The centerline was attached to the canopy apex with a clevis after serving the apex. The clevis was then wrapped using cloth tape to protect the canopy.
2. The canopy apex was pulled down and the centerline attached to the suspension riser confluence clevis prior to making the canopy assembly ties. All other packing procedures remained unchanged.

EXTRACTION FORCE TRANSFER DEVICE RIGGING PROCEDURES

35K Extraction Force Transfer Device

U.S. Army FM 10-500/U.S. Air Force TO 13C7-1-5 was used to rig the 35K device with the following exception: The cover plate on the actuator was removed and the actuator rotating arm was tied in the cocked position with 1000-pound BS tubular nylon webbing. The webbing was passed around the actuator spring cylinder and through two CBS cutters. The CBS cutters were tied to the platform side rail with 1000-pound BS tubular nylon webbing.

Guillotine Knife System

The guillotine knife system was permanently mounted in the aft end of the weight-test platform. A 2- or 4-ply, Type XXVI nylon cutter web was placed around the spool (anvil) and attached at two points to a 4-point clevis in the extraction system. The guillotine knife was restrained in the cocked position by a shear web which was run through two CBS cutters. The CBS cutters were attached to a loop of 4000-pound BS tubular nylon webbing tied around the ballast restraint pipes in the weight-test platform.

LOADING PROCEDURES

All loads were loaded aboard the aircraft in accordance with procedures described in U.S. Air Force TO 1C-130A-9.

PREFLIGHT PROCEDURES

After the load was placed on board the aircraft, the CBS cutter initiating lanyards were tied to a D-ring on the floor of the aircraft and the open link safety clevis initiating lanyard was connected to the static line.

INFLIGHT PROCEDURES

Inflight procedures for airdropping platform-mounted loads were as specified in 6511th Test Squadron Checklist LCL-C130-6511-1C1-3, Series I (Go-No-Go Equipped Extraction System). At three minutes prior to drop, the safety pins on the CBS cutters were removed. At zero time, the extraction parachute was deployed from the aircraft pendulum release system.

POST TEST PROCEDURES

After each test the test system was inspected for damage.

TEST RESULTS

Test results are presented in Tables 1 and 2. A narrative of individual test results and test item development is contained in Appendix B.

On one test, the force transfer device malfunctioned and the recovery parachute was not deployed.

During first-stage descent, most loads tended to oscillate about the pitch axis. This oscillation would increase as the vertical speed increased, and would decrease as the load center-of-gravity was moved forward. (R1) Forward is the direction of load movement through the air. When the extraction/stabilization parachute attachment point was located at the aft extremity of the load, load oscillation was also reduced. (R2) Oscillation about the yaw axis also occurred, but it was not as common or as severe as oscillation about the pitch axis. Potentially damaging contact was observed between the slings and the load whenever the load rotated to an inverted or sideways attitude immediately following force transfer. The fire hose padding protected the suspension slings from this damage. Contact between the three recovery parachutes while in the reefed condition was observed when the 40-foot reefing line was used. Adequate separation between the parachutes was observed on the drop in which a 30-foot reefing line was used. On three tests, the recovery parachutes equipped with 40-foot reefing lines incurred extensive damage during deployment and opening. (R3)

CONCLUSIONS AND RECOMMENDATIONS

The most significant problem encountered during this program was test load oscillation during first stage descent. The degree of oscillation was dependent upon the longitudinal position of the center-of-gravity, the vertical speed, and the position of the extraction stabilization parachute attachment point on the load.

1. *This test system should only be used on loads with forward-located centers of gravity (forward being the direction of load movement through the air).* (Page 10)
2. *The extraction/stabilization parachute attachment point should be located on the aft extremity of the platform/load.* (Page 10)

Platform rotation from vertical to horizontal following force transfer was erratic. A reliable method to insure an acceptable rotation of the platform from vertical to horizontal was not developed.

¹ Boldface numerals preceded by an R correspond to the recommendation numbers tabulated in the Conclusions and Recommendations Section of this report.

The recovery parachutes equipped with 40-foot reefing lines incurred significant damage during the reefed open period.

3. *The use of shorter recovery parachute reefing lines and longer reefed open periods should be investigated. (Page 10)*

TABLE 1
SINGLE RECOVERY PARACHUTE SYSTEM (CONFIGURATION 1)¹ TEST RESULTS

All Tests Were Conducted From a C-130 Aircraft
Flying at an Indicated Airspeed of 150 Knots.
Modular Platforms Had a Projected Frontal Area
of 21 Square Feet.

Test sequence No.	Mean sea level/altitude at test initiation (ft)	Test platform load gross weight (lb)	Test platform length (ft)	Extraction diameter (ft)	Stabilization parachute installed length (in)	Cutting time (sec)	Reefing line length (ft)	Reefing line time (sec)	Cutting delay (sec)	Maximum force (lb)	Stabilization method (A, B)	Maximum force (lb)	Altitude loss from test initiation to force transfer (ft)
1	10,620	2700	8	15	None	40	20	2	2	(4)	A	(4)	5770
2	9,240	2700	8	15	2.56	40	20	2	2	5000	A	1250	5670
3	9,590	2700	8	15	2.56	40	20	2	2	5500	B	1600	5980
4	8,610	3490	8	15	1.44	30	20	2	2	2700	B	1500	5440
5	10,380	5200	12	15	None	40	40	2	2	7000	B	100	7470
6	8,940	5200	12	15	1.44	30	40	4	4	3000	B	(6)	(6)
7	9,990	5200	12	15	1.44	30	40	4	4	3100	B	2700	6830
7g	8,890	7870	12	15	None	30	40	4	4	7550	B	6000	5930

Test sequence No.	Maximum true vertical speed before force transfer (ft/sec)	Longitudinal position of load center-of- gravity ² (ft)	True vertical speed at force transfer (ft/sec)	First stage oscillations ³ Pitch (degrees)	Load Yaw (degrees)	Recovery parachute snatch force pull-down line		Recovery parachute reefed open force pull-down line		Recovery parachute full open force pull-down line		Maximum slings force Forward Aft (lb)
						Vent (lb)	Total (lb)	Vent (lb)	Total (lb)	Vent (lb)	Total (lb)	
1	162	4.16	156	+10,-30	---	(4)	(4)	(4)	(4)	(4)	(4)	(4)
2	173	4.16	148	+80	---	600	800	2600	7400	4500	2600	4500
3	174	3.84	166	+45	+30	(5)	(5)	(5)	(5)	(5)	(5)	(5)
4	234	3.39	230	+30	---	620	2650	1700	4600	7900	3410	2000
5	223	3.61	212	0	---	1790	6000	5200	12,000	15,600	6330	2550
6	235	5.41	(6)	+90	+45	(6)	(6)	(6)	(6)	(6)	(6)	(6)
7	293	3.61	291	+20	---	1500	7700	6000	14,200	15,000	5600	5550
7g	261	4.69	257	+0,-30	---	2650	9100	5400	14,700	13,900	5300	7850

Footnotes

- 1 See Appendix A.
- 2 The longitudinal position of the center-of-gravity was measured from the front edge of the platform.
- 3 Test load oscillation (Figure 5) was determined by visual estimate from motion picture film.
- 4 This load was not instrumented.
- 5 Test data were not acquired due to telemetric equipment damage.
- 6 Force transfer did not occur.
- 7 The recovery parachute suffered a tear from the skirt to apex on reefed opening. The parachute slowly opened after disreef.

TABLE 2
MULTIPLE RECOVERY PARACHUTE SYSTEM (CONFIGURATION II) TEST RESULTS

All Tests Were Conducted From a C-130 Aircraft
All Test Loads Were Mounted on 12-Foot Type II
Modular Platforms and Had a Projected Frontal Area
of 30 Square Feet

Test sequence No.	Launch altitude (ft)	Mean sea level altitude	Pitch (degrees)	First stage load oscillation ³ Yaw	Test Extraction/stabilization parachute		GLIA recovery parachute		Rigging configuration ¹	Maximum force during extraction	Stabilization parachute force at force transfer	Altitude lost from test initiation to speed before force transfer	Maximum true vertical speed before force transfer
					Test load weight diameter in.	Reefing line length	CBS cutter delay length	Recovery reefing line length					
9	8060	130	+10,-10	+5	3600	4150	4000	(4)	4500	2600	(4)	5270	150
10	9060	150	+10,-30	+5	(5)	(5)	(5)	(5)	(5)	(5)	(5)	6300	191
11	8260	150	+15,-40	---	3860	4000	(4)	10,800	3700	3980	(4)	5120	214
12	8810	150	+10,-20	---	4100	3600	4500	12,800	7500	2550	(5)	6200	283
13	8740	150	+15,-25	+30	4200	3966	4000	11,500	(5)	(5)	(5)	5610	234
14	9600	150	+5	+5	7350	6900	6450	19,200	17,150	8500	11,300	7480	240
7,15	9410	150	+5,-15	+5	(5)	(5)	(5)	20,000	12,550	14,800	35,900	6570	190
8,16	8410	150	+5,-20	---	(5)	(5)	(5)	(5)	(5)	(5)	(5)	4990	224
9,17	10,280	150	+0,-15	+5	(5)	(5)	(5)	17,900	(5)	(5)	(5)	6550	289
10,18	10,170	150	+20,-60	---	(3)	7800	7250	22,600	(5)	23,800	16,550	7210	213
10,19	10,240	150			8180	(3)	(3)	26,000	9580	(5)	27,200	6600	306

Test sequence No.	Longitudinal load center-of- gravity ² (ft)	Recovery parachute snatch force		Recovery parachute reefed open force		Recovery parachute full open force		Total	Maximum slings force	
		No. 1	No. 2	No. 3	Total	No. 1	No. 2			No. 3
9	5.05	(1b)	(1b)	(1b)	(1b)	(1b)	(1b)	(4)	10,200	4950
10	5.05	(5)	(5)	(5)	(5)	(5)	(5)	(5)	(5)	(5)
11	4.03	(4)	(4)	(4)	(4)	(4)	(4)	(4)	7450	6,980
12	3.62	(5)	(5)	(5)	(5)	(5)	(5)	(5)	2900	7600
13	5.12	(5)	(5)	(5)	(5)	(5)	(5)	(5)	11,300	13,450
14	4.33	(5)	(5)	(5)	(5)	(5)	(5)	(5)	7000	18,000
7,15	4.13	(5)	(5)	(5)	(5)	(5)	(5)	(5)	16,450	27,000
8,16	4.18	(5)	(5)	(5)	(5)	(5)	(5)	(5)	(5)	(5)
9,17	4.33	(5)	(5)	(5)	(5)	(5)	(5)	(5)	19,990	14,950
10,18	4.20	(3)	(3)	(3)	(3)	(3)	(3)	(3)	14,450	27,200
10,19	6.58	(3)	(3)	(3)	(3)	(3)	(3)	(3)	29,500	11,500

Footnotes

- See Appendix A.
- The longitudinal position of the center of gravity was measured from the front edge of the platform.
- Test load oscillation (Figure 5) was determined by visual estimate from motion picture film.
- Data were invalidated due to strain gage being subjected to torsion.
- These data were not acquired due to telemetric equipment damage.
- Recovery parachute opened slowly after disteef.
- One recovery parachute suffered a tear from skirt to apex on reefed opening. Chute No. 1 had blown sections, burn damage, and broken lines. Chute No. 2 had burn damage. Chute No. 3 had a tear from skirt to apex.
- All three recovery parachutes suffered extensive damage on reefed opening. Chute No. 1 had a tear from skirt to apex. Chute No. 2 had several tears from skirt to apex and separation of approximately 20 feet from the lower lateral band. Chute No. 3 had several tears from skirt to apex. Chute No. 2 never achieved full open. Chute No. 3 collapsed after disteef and then slowly reopened.
- Chute No. 3 suffered a tear in the center half of one gore.

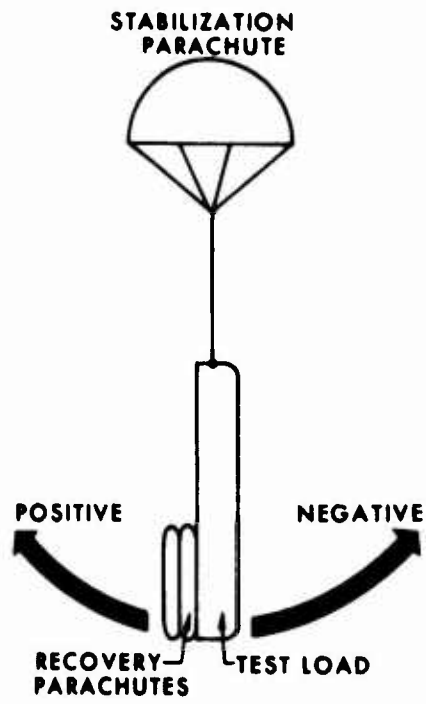

Figure 5. Test Load Oscillation.

Appendix A

TEST ITEM CONFIGURATION AND RIGGING METHODS

TABLE A1

Test Item Configuration and Rigging Method Matrix

Test sequence No.	Test item configuration (Fig ref)	Force transfer device (Fig ref)	Suspension sling confluence point connection (Fig ref)	Rigging Method (Fig ref)	Suspension sling confluence point break tie (Fig ref)
1	A1	A2	A1	A10	A10
2	A1	A2	A1	A10	A10
3	A1	A2	A1	A11	A11
4	A1	A2	A1	A11	None used
5	A1	A3	A1	A11	None used
6	A1	A3	A1	A11	None used
7	A1	A4	A1	A11	None used
8	A1	A4	A1	A11	None used
9	A5	A4	A6	A12	A13
10	A5	A4	A6	A12	A13
11	A5	A4	A7	A12	A14
12	A5	A4	A7	A12	A14
13	A5	A4	A7	A12	A14
14	A5	A4	A7	A12	A14
15	A5	A4	A7	A12	A14
16	A5	A4	A8	A12	A14
17	A5	A4	A8	A12	A14
18	A5	A4	A9	A12	A14
19	A5	A4	A9	A15	A14

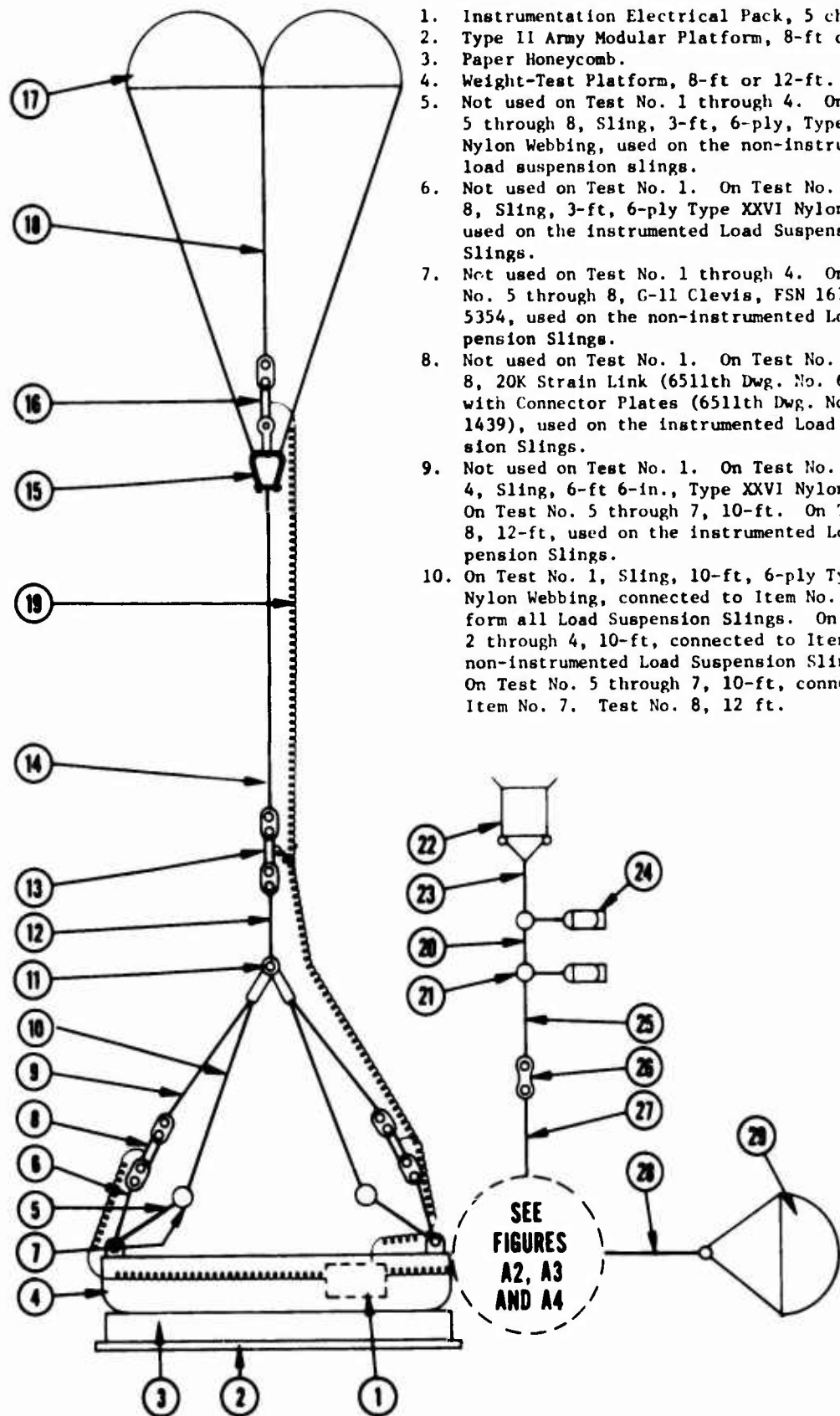

1. Instrumentation Electrical Pack, 5 channels.
2. Type II Army Modular Platform, 8-ft or 12-ft.
3. Paper Honeycomb.
4. Weight-Test Platform, 8-ft or 12-ft.
5. Not used on Test No. 1 through 4. On Test No. 5 through 8, Sling, 3-ft, 6-ply, Type XXVI Nylon Webbing, used on the non-instrumented load suspension slings.
6. Not used on Test No. 1. On Test No. 2 through 8, Sling, 3-ft, 6-ply Type XXVI Nylon Webbing, used on the instrumented Load Suspension Slings.
7. Not used on Test No. 1 through 4. On Test No. 5 through 8, G-11 Clevis, FSN 1670-090-5354, used on the non-instrumented Load Suspension Slings.
8. Not used on Test No. 1. On Test No. 2 through 8, 20K Strain Link (6511th Dwg. No. 64B1343) with Connector Plates (6511th Dwg. No. 64B1439), used on the instrumented Load Suspension Slings.
9. Not used on Test No. 1. On Test No. 2 through 4, Sling, 6-ft 6-in., Type XXVI Nylon Webbing. On Test No. 5 through 7, 10-ft. On Test No. 8, 12-ft, used on the instrumented Load Suspension Slings.
10. On Test No. 1, Sling, 10-ft, 6-ply Type XXVI Nylon Webbing, connected to Item No. 4 to form all Load Suspension Slings. On Test No. 2 through 4, 10-ft, connected to Item No. 4, non-instrumented Load Suspension Slings only. On Test No. 5 through 7, 10-ft, connected to Item No. 7. Test No. 8, 12 ft.

Figure A1. Test Item Configuration 1.

Figure A1. (Continued)

11. G-11 Clevis, FSN 1670-090-5354 (2 ea.), one standard and one spread to a 4-in. opening.
12. Not used on Test No. 1. On Test No. 2 through 8, Sling, 3-ft, 6-ply Type XXVI Nylon Webbing.
13. Not used on Test No. 1. On Test No. 2 through 8, 20K Strain Link (6511th Dwg. No. 64B1343) with Connector Plates (6511th Dwg. No. 68B1439).
14. On Test No. 1, Sling, 20-ft, 6-ply Type XXVI Nylon Webbing, connected to Item No. 11. On Test No. 2 through 8, Sling, 16-ft, 6-ply Type X Nylon Webbing, connected to Item No. 13.
15. G-11 Clevis, FSN 1670-090-5354.
16. Not used on Test No. 1. On Test No. 2 through 8, 10K Strain Link (6511th Dwg. No. 64B1343) with locally manufactured connecting hardware.
17. G-11 Parachute, FSN 1670-269-1107.
18. Vent Pulldown Line, US Army Natick Development Center Dwg. No. X11-1-1547. On Test No. 1, connected to Item No. 15. On Test No. 2 through 8, connected to Item No. 16.
19. Strain Link Electrical Lead, not used on Test No. 1.
20. Sling, 3-ft, 2-ply Type XXVI Nylon Webbing.
21. Connector Link, 15,000-lb capacity, MS 24553-1 (2 ea.).
22. G-11 Deployment Bag, FSN 1670-368-4219.
23. G-11 Deployment Bag Bridle, FSN 1670-377-9388.
24. Release Knife, FSN 1670-836-2231 (2 ea.), tied to Item No. 21 with 4000-lb breaking strength tubular Nylon Webbing, FSN 8305-082-5753.
25. Sling, 6-ft, 2-ply Type XXVI Nylon Webbing.
26. Open Link Safety Device (go-no-go).
27. Sling, 6-ft, 2-ply Type XXVI Nylon Webbing.
28. Extraction Line, 60-ft, FSN 1670-856-0265.
29. Extraction Parachute, 15-ft diameter ring slot, FSN 1670-052-1548.

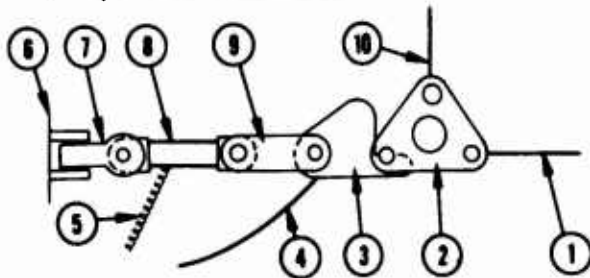

1. Extraction Line.
2. 3-point Extraction Link, FSN 1670-432-2516.
3. 35K Extraction Force Transfer Device Coupling, FSN 1670-434-5783.
4. 35K Extraction Force Transfer Device Actuator Cable, 12-ft, FSN 1670-434-5783.
5. Strain Link Electrical Lead.
6. Weight-Test Platform, 6511th Dwg. No. 66D1391.
7. Universal Strain Link Connector, 6511th Dwg. No. 69C1512.
8. 30K Strain Link, 6511th Dwg. No. 64B1342.
9. Connector Plates, 6511th Dwg. No. 67C1415 (2 ea.).
10. Recovery Parachute Deployment Line.

Figure A2. Force Transfer Device Used with Configuration I on Tests No. 1 through 4.

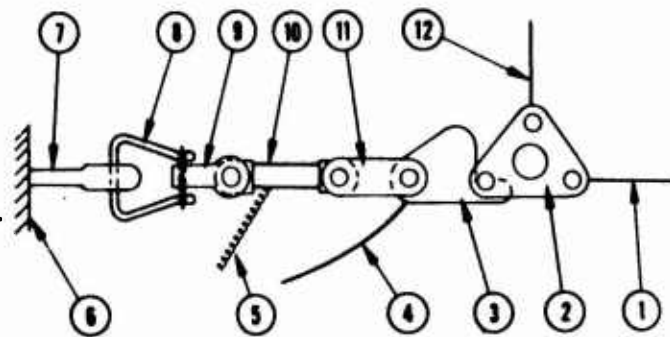

1. Extraction Line.
2. 3-point Extraction Link, FSN 1670-432-2516.
3. 35K Extraction Force Transfer Device Coupling, FSN 1670-434-5783.
4. 35K Extraction Force Transfer Device Actuator Cable, FSN 1670-434-5783.
5. Strain Link Electrical Lead.
6. Weight-Test Platform, 6511th Dwg. No. 68E1474.
7. Pintle, FSN 2540-776-0103.
8. G-11 Clevis, FSN 1670-090-5354.
9. Universal Strain Link Connector, 6511th Dwg. No. 69C1512.
10. 30K Strain Link, 6511th Dwg. No. 64B1342.
11. Connector Link, 6511th Dwg. No. 67C1415 (2 ea.).
12. Recovery Parachute Deployment Line.

Figure A3. Force Transfer Device Used with Configuration I on Tests No. 5 and 6.

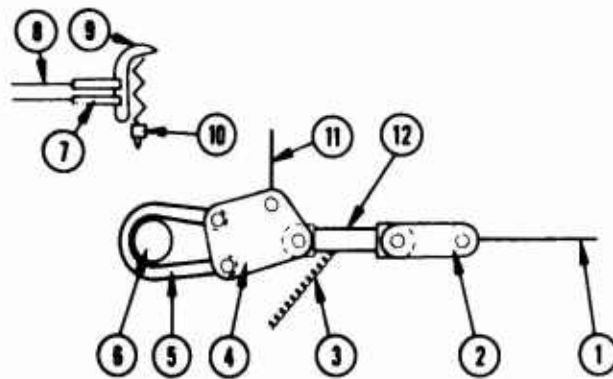

1. Extraction Line
2. Connector Plate, 6511th Dwg. No. 67C1415.
3. Strain Link Electrical Lead.
4. 4-point Extraction/Deployment Clevis For 15-ft extraction parachute - 6511th Dwg. No. 69D1496. For 22- and 28-ft extraction parachute - 6511th Dwg. No. 69D1497.
5. Shear Web, 4-ft, Type XXVI nylon webbing. For 15- and 22-ft extraction parachute, 2-ply. For 28-ft extraction parachute, 4-ply.

Figure A4. Force Transfer Device Used with Configuration I on Tests No. 7 and 8 and with Configuration II on Tests No. 9 through 19.

Figure A4. (Continued)

6. Cutter Anvil, part of guillotine knife force transfer device, 6511th Dwg. No. 69E1514.
7. CBS Cutter, (2 ea).
8. CBS Cutter Initiating Lanyard, 1000-lb BS tubular nylon webbing, FSN 8305-082-5752 (2 ea).
9. Shear Tie, 2300-lb BS nylon webbing, FSN 8305-082-5751.
10. Guillotine Knife, part of guillotine knife force transfer device.
11. Recovery Parachute Deployment Line.
12. Strain Link, either 20K (6511th Dwg. No. 64B1343) or 30K (6511th Dwg. No. 64B1342).

1. Instrumentation Electrical Pack, 7 channels.
2. Type II Army Modular Platform, 12-ft.
3. Paper Honeycomb.
4. Weight-Test Platform, 8-ft or 12-ft.
5. Sling, 3-ft, 6-ply Type XXVI Nylon Webbing, used on all Load Suspension Slings.
6. 20K Strain Link (6511th Dwg. No. 64B1343) with Connector Plates (6511th Dwg. 68B1439), used on the instrumented Load Suspension Slings.
7. G-11 Clevis, FSN 1670-090-5354, used on the non-instrumented Load Suspension Slings.
8. Sling, 12-ft, 6-ply Type XXVI Nylon Webbing, used on all Load Suspension Slings.
9. Sling, 3-ft, 6-ply Type XXVI Nylon Webbing (3 ea.).
10. 20K Strain Link (6511th Dwg. No. 64B1343 (3 ea.), with Connector Plates (6511th Dwg. No. 68B1439).
11. Sling, 40-ft, 6-ply Type X, Nylon Webbing (3 ea.).
12. G-11 Clevis, FSN 1670-090-5354 (3 ea.).
13. G-11 Parachute, FSN 1670-269-1107 (3 ea.).
14. Vent Pulldown Line, US. Army Natick Development Center Dwg. No. X11-1-1547 (3 ea.).
15. Connector Link, 15,000-lb capacity, MS 24553-1 (3 ea.).
16. Y-Bridle, 7-ft, 6511th Dwg. No. 74C1719 (2 ea.).
17. G-11 Clevis, FSN 1670-090-5354.
18. Strain Link Electrical Leads.
19. G-11 Deployment Bag, FSN 1870-368-4219 (3 ea.).
20. G-11 Deployment Bag Bridle, FSN 1670-377-9388 (3 ea.).
21. Release Knife Line, 6000-lb BS Nylon Webbing, FSN 8305-682-6803.
22. Release Knife, FSN 1670-836-2231 (4 ea.).
23. Sling, 8-ft, 6-ply Type XXVI Nylon Webbing.
24. Open Link Safety Device (go-no-go).
25. Sling, 6-ft, 6-ply Type XXVI Nylon Webbing.
26. Extraction Parachute, ring slot, 15-ft diameter (FSN 1670-052-1548), 22-ft diameter (FSN 1670-687-5458), or 28-ft diameter (Part No. X67K 1901).
27. Extraction Line, 60-ft, FSN 1670-856-0265, for 15-ft Parachute, FSN 1670-045-9972 for 22- and 28-ft Parachute.

Figure A5. Test Item Configuration II.

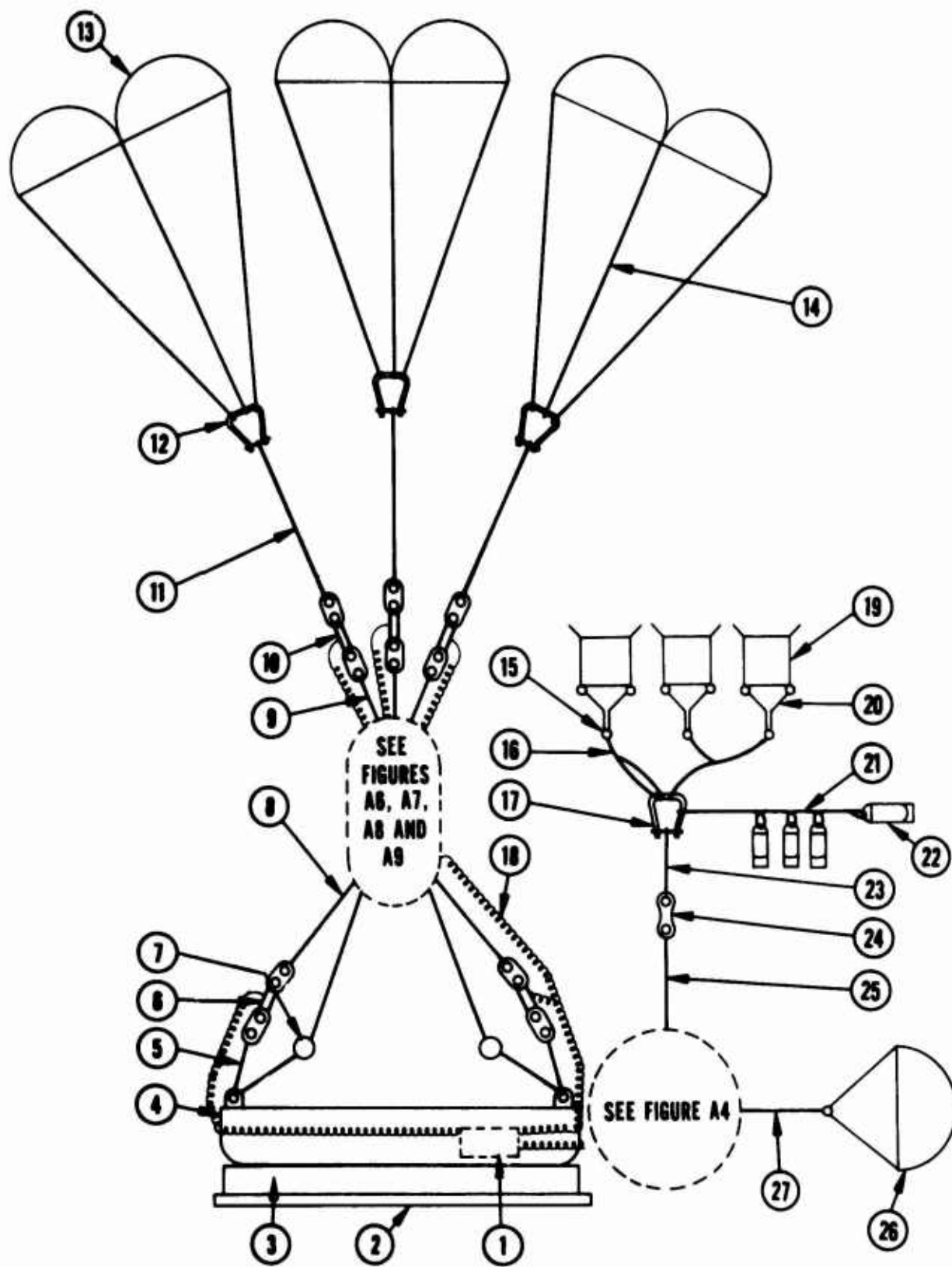
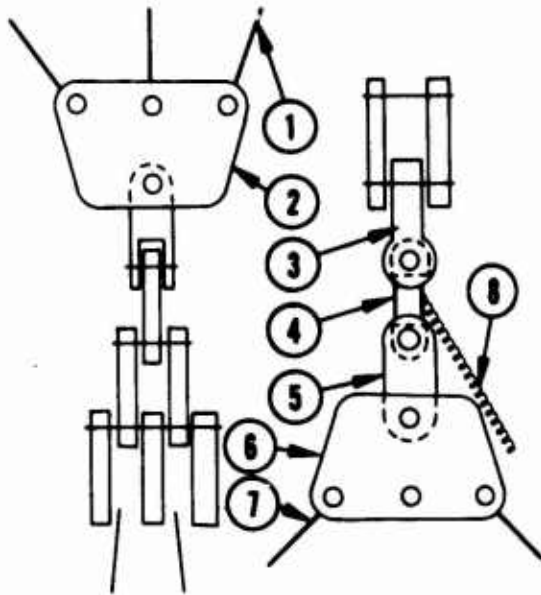
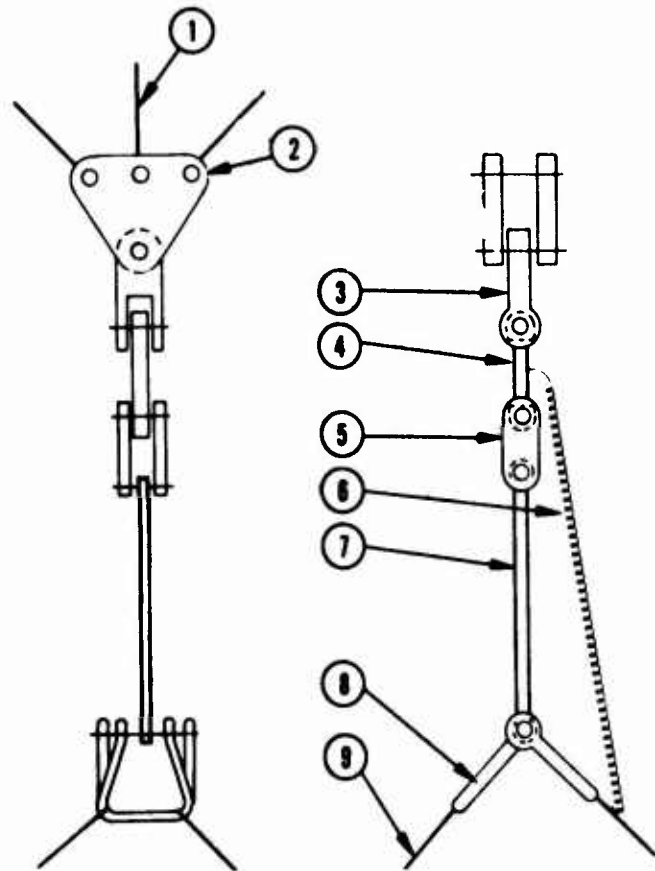

Figure A5. (Continued)



1. Sling, 3-ft, 6-ply Type XXVI nylon webbing (3 ea).
2. 4-point Separator Clevis without Separator, 6511th Dwg. No. 65D3820 (2 ea).
3. Universal Strain Link Connector, 6511th Dwg. No. 69C1512.
4. 30K Strain Link, 6511th Dwg. No. 64B1342.
5. Connector Plate, 6511th Dwg. No. 67C1415 (2 ea).
6. Same as Item No. 2 (3 ea.)
7. Load Suspension Slings (4 ea.).
8. Strain Link Electrical Lead.

Figure A6. Suspension Sling Confluence Point Connection Used with Configuration II on Tests No. 9 and 10.



1. Sling, 3-ft, 6-ply, Type XXVI Nylon Webbing (3 ea).
2. 4-point Connector Plate, 6511th Dwg. No. 69D1497 (2 ea.).
3. Universal Strain Link Connector, 6511th Dwg. No. 69C1512.
4. 30K Strain Link, 6511th Dwg. No. 64B1342.
5. Connector Plate, 6511th Dwg. No. 67C1415 (2 ea.).
6. Strain Link Electrical Lead.
7. Sling, 4-ft, 8-ply, Type XXVI Nylon Webbing.
8. G-11 Clevis, FSN 1670-090-5354 (2 ea.), one standard and one spread to 4-in. opening.
9. Load Suspension Sling (4 ea.).

Figure A7. Suspension Sling Confluence Point Connection Used with Configuration II on Tests No. 11 through 15.

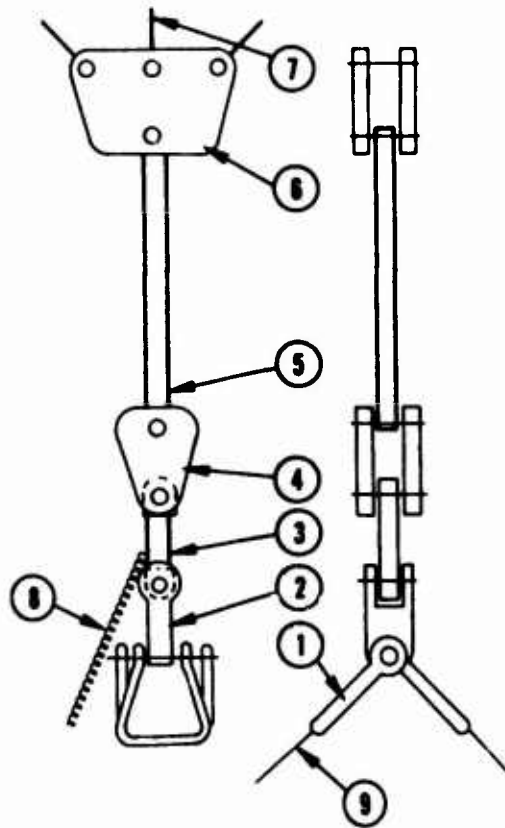

1. G-11 Clevis, FSN 1670-090-5354 (2 ea.), one standard and one spread to 4-in. opening.
2. Universal Strain Link Connector, 6511th Dwg. No. 69C1512.
3. 30 or 50K Strain Link, 6511th Dwg. No. 64B1342.
4. 2-point, 1-separator Clevis, 6511th Dwg. No. 68B1483 (2 ea.).
5. Sling, 4-ft, 12-ply, Type XXVI nylon webbing, fabricated to fit items No. 4 and 6.
6. 4-point Separator Clevis, 6511th Dwg. No. 65D3820 (2 ea.).
7. Sling, 3-ft, 6-ply, Type XXVI Nylon Webbing.
8. Strain Link Electrical Lead.
9. Load Suspension Sling (4 ea.).

Figure A8. Suspension Sling Confluence Point Connection Used with Configuration II on Tests No. 16 and 17.

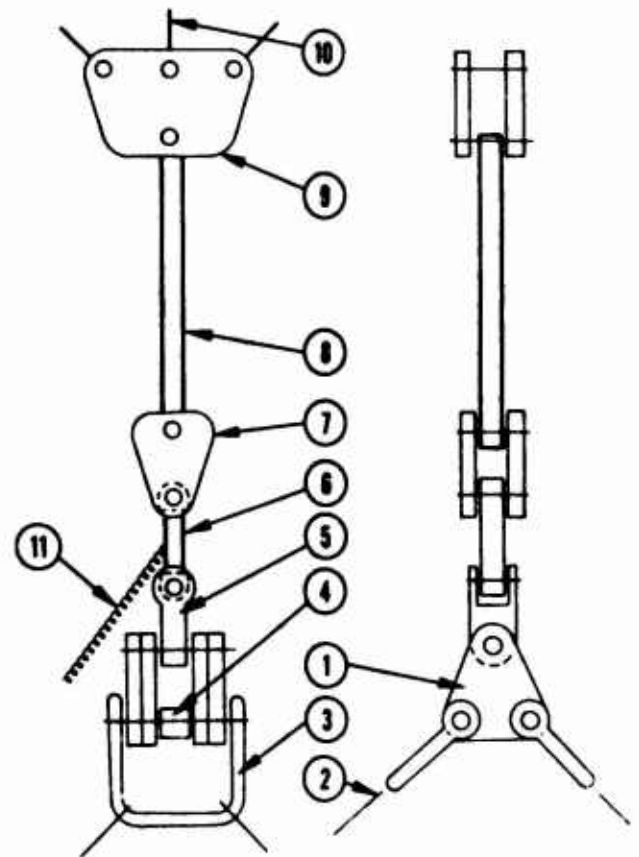

1. 3-point Separator Clevis without Separator, (4 ea.), 6511th Dwg. No. 69D1515 (4 ea.).
2. Load Suspension Slings (4 ea.).
3. G-11 Clevis, FSN 1670-090-5354 modified to 4-in. opening (2 ea.).
4. Bushing, 1-in. internal diameter and 1-3/4-in. wide (2 ea.).
5. Universal Strain Link Connector, 6511th Dwg. No. 69C1512.
6. 50K Strain Link, 6511th Dwg. No. 64B1342.
7. 2-point, 1-Separator Clevis, 6511th Dwg. No. 68B1483 (2 ea.).
8. Sling, 4-ft, 2-ply, Type XXVI Nylon Webbing, fabricated to fit items No. 8 and 9.
9. 4-point Separator Clevis, 6511th Dwg. No. 65D3820 (2 ea.).
10. Sling, 3-ft, 6-ply, Type XXVI Nylon Webbing.

Figure A9. Suspension Sling Confluence Point Connection Used with Configuration II on Tests No. 18 and 19.

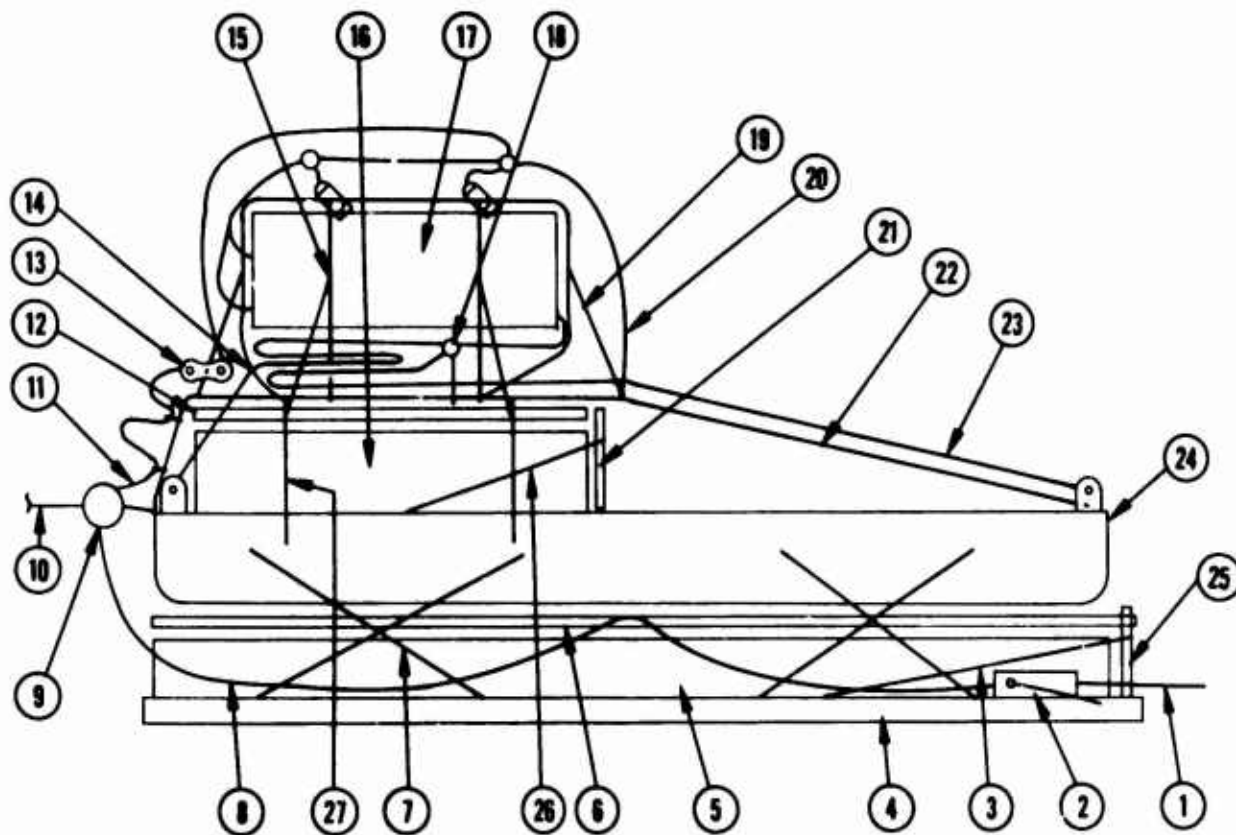

1. CBS Cutter Activating Lanyard, 1000-lb BS Nylon Webbing, FSN 8305-082-5752, tied to floor of aircraft (2 ea.).
2. 35K Extraction Force Transfer Device Actuator, FSN 1670-434-5783.
3. Strap, 15-ft, dacron, FSN 1670-360-0540, holds Item No. 25 in place.
4. Type II Army Modular Platform, 8-ft, FSN 1670-893-1624 and 1670-893-1625.
5. Paper Honeycomb, 3 layers, glued to Item No. 4, FSN 1670-753-3928.
6. Plywood, 3/4-in. thick, 4-ft X 8-ft pieces (2 ea.), with cutouts for Item No. 7.
7. Tiedown Straps, 15-ft, dacron (FSN 1670-360-0540) with Load Binder (FSN 3990-360-0248) and D-Ring (FSN 5365-937-0147), four forward and four aft.
8. 35K Extraction Force Transfer Device Actuator Cable, FSN 1670-434-5738, tied along length in three places to Item No. 4 and 24.
9. Force Transfer Device.
10. Extraction Line.
11. Recovery Parachute Deployment Line, tied to Item No. 22 in a minimum of two places with 350-lb BS cotton webbing (FSN 8305-263-3616).
12. Plywood, 3/4-in. thick, 4 ft X 5 ft.
13. Open Link Safety Device (go-no-go), tied to Item No. 12 in six places with one turn of 550-lb BS Nylon Cord (FSN 4020-240-2146).
14. Aft Load Suspension Sling (2 ea.), Webbing covered with 2-1/2-in. fire hose, strain link, and clevis covered with 6-in. fire hose.
15. Recovery Parachute Lateral Restraint Tie (2 ea.), 4000-lb BS Nylon Webbing, FSN 8305-082-5753.
16. Paper Honeycomb, 5 layers, FSN 1670-753-3928.
17. Recovery Parachute with Deployment Bag.
18. Double G-11 Clevis, tied to Item No. 22 with one turn of 550-lb BS Nylon Cord (FSN 4020-240-2146).
19. Recovery Parachute Forward Aft Restraint Tie, 4000-lb BS Nylon Webbing, FSN 8305-082-5753.
20. Break Tie, 1 strand of 350-lb BS Cotton Webbing (FSN 8305-263-3616).
21. Plywood, 3/4 in. X 48 in. X 15 in.
22. Chain, 10,000-lb capacity (FSN 1670-516-8405) with Connecting Device (FSN 1670-212-1149).
23. Forward Load Suspension Sling (2 ea.), webbing covered with 2-1/2-in. fire hose, strain link and clevis covered with 6-in. fire hose.
24. Weight-Test Platform, 8-ft, 6511th Dwg. No. 66D1391.
25. Plywood, 3/4" thick, 4 ft X 1 ft.
26. Strap, 15-ft, dacron, FSN 1670-360-0540, holds Item No. 21 in place.
27. Chain, 10,000-lb capacity (2 ea.), (FSN 1670-516-8405) with Connecting Device (FSN 1670-212-1149).

Figure A10. Rigging Method A Used on Test Item Configuration I, on Tests No. 1 and 2.

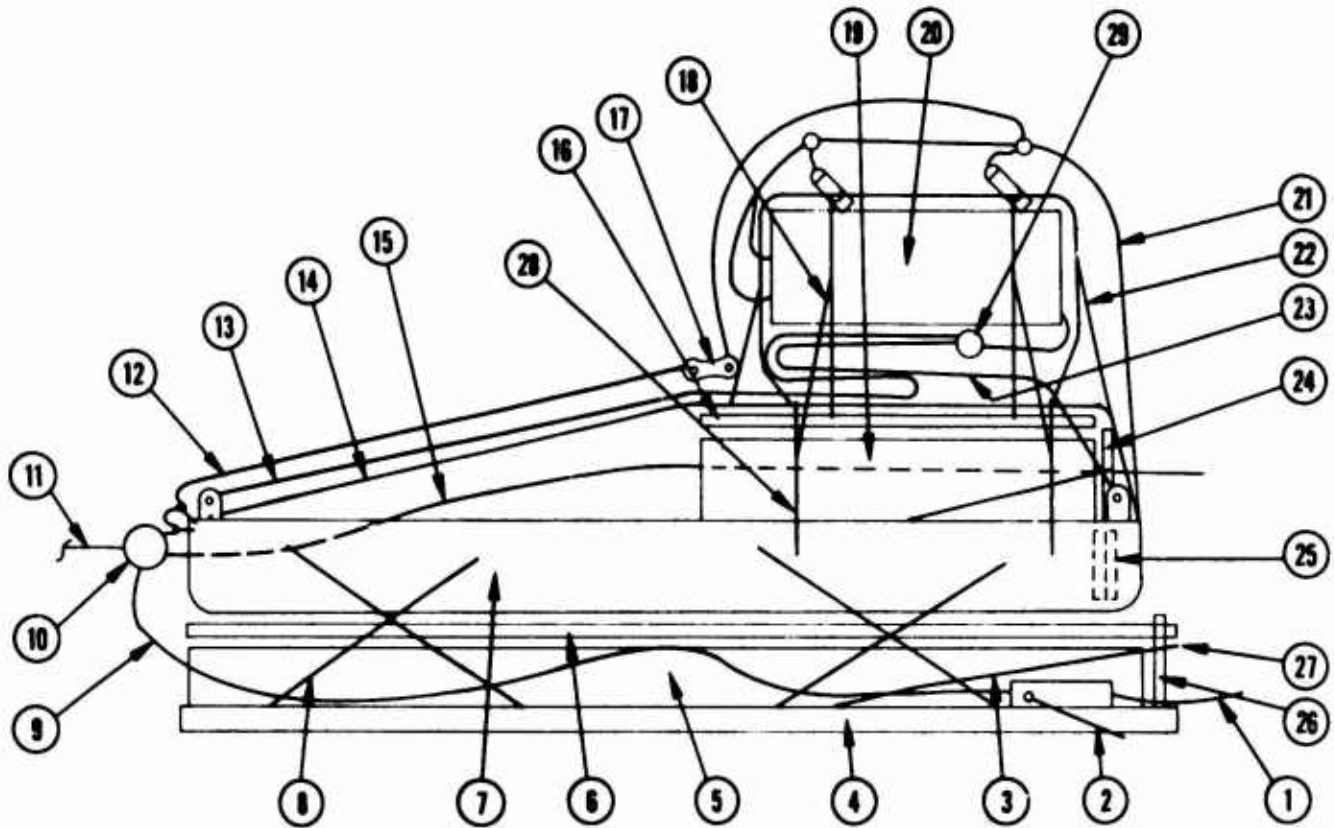

1. Not used on Test No. 7 and 8. On Test No. 3 through 6, CBS Cutter Activating Lanyard (2 ea.), 1000-lb BS Nylon Webbing, FSN 8305-082-5752, tied to floor of aircraft.
2. Not used on Test No. 7 and 8. On Test No. 3 through 6, 35K Extraction Force Transfer Device Actuator, FSN 1670-434-5738.
3. Not used on Test No. 5 through 8. On Test No. 3 and 4, Strap, 15-ft, dacron, FSN 1670-360-0540, holds Item No. 26 in place.
4. Type II Army Modular Platform. On Test No. 3 and 4, 8-ft, FSN 1670-893-1624 and 1670-893-1625. On Test No. 5 through 8, 12-ft, FSN 1670-893-1624 and 1670-893-1626.
5. Paper Honeycomb, 3 layers, FSN 1670-753-3928.
6. Not used on Test No. 5 through 8. On Test No. 3 and 4, Plywood, 3/4 in. thick (2 ea.), 4-ft X 8-ft pieces with cutouts for Item No. 7.
7. Weight-Test Platform. On Test No. 3 and 4, 8-ft, 6511th Dwg. No. 66D1391. On Test No. 5 through 7, 8-ft, 6511th Dwg. No. 68E1474. On Test No. 8, 12-ft, 6511th Dwg. No. 68E1492. On Test No. 3 through 5, 7, and 8, forward edge of weight test platform was even with forward edge of Item No. 4. On Test No. 6, forward edge of weight test platform was 2 feet aft of forward edge of Item No. 4.
8. On Test No. 3 and 4, Tiedown Straps, 15-ft, dacron (FSN 1670-360-0540) with load binder (FSN 3990-360-0248) and D-Ring (FSN 5365-937-0147), four forward and four aft. On Test No. 5 through 8, Tiedown Chains, 10,000-lb capacity (FSN 1670-516-8405) with Connecting Device (FSN 1670-212-1149), four forward and four aft.
9. Not used on Test No. 7 and 8. On Test No. 3 through 6, 35K Extraction Force Transfer Device Actuator Cable, FSN 1670-434-5738, tied along length in three places to Item No. 4 and 7.
10. Force Transfer Device.
11. Extraction Line.
12. Recovery Parachute Deployment Line, tied to Item No. 7 in a minimum of two places with 350-lb BS cotton webbing (FSN 8305-263-3616).
13. Aft Load Suspension Sling (2 ea.), webbing covered with 2-1/2-in. fire hose, strain link and clevis covered with 6-in. fire hose.
14. Chain, 10,000-lb capacity (FSN 1670-516-8405) with Connecting Device (FSN 1670-212-1149).
15. Not used on Test No. 3 through 6. On Test No. 7 and 8, CBS Cutter Activating Lanyard, (2 ea.), 1,000-lb BS Nylon Webbing, FSN 8305-082-5752, tied to floor of aircraft.
16. Plywood, 3/4-in. thick. On Test No. 3, 7, and 8, 4 ft X 5 ft. On Test No. 4 through 6, 4 ft X 7 ft.
17. Open Link Safety Device (go-no-go), tied to Item 16 in six places with one turn of 550-lb BS Nylon Cord (FSN 4020-240-2146).

Figure A11. Rigging Method B Used on Test Item Configuration I on Tests No. 3 through 8.

Figure A11. (Continued)

18. Recovery Parachute Lateral Restraint Tie (2 ea.), 4000-lb BS Nylon Webbing, FSN 8305-082-5753.
19. Paper Honeycomb, FSN 1670-753-3928. On Test No. 3 and 4, 5 layers. On Test No. 5 through 8, 3 layers.
20. Recovery Parachute with Deployment Bag.
21. Break Tie, 350-lb BS cotton Webbing, FSN 8305-263-3616. On Test No. 3 and 4, one strand. On Test No. 5 through 8, two strands.
22. Recovery Parachute Forward/Aft Restraint Tie, 4000-lb BS Nylon Webbing, FSN 8305-082-5753.
23. Forward Load Suspension Sling, 2 ea., webbing covered with 2-1/2-in. fire hose, strain link and clevis covered with 6-in. fire hose.
24. Not used on Test No. 5 through 8. On Test No. 3 and 4, Plywood, 3/4-in. thick, 48 in. X 15 in.
25. Not used on Test No. 3. On Test No. 4 through 8, Weight Test Platform Ballast, put in forward-most slots of Item No. 7.
26. Not used on Test No. 5 through 8. On Test No. 3 and 4, Plywood, 3/4-in. thick, 4 ft X 1 ft.
27. Same as Item No. 3. Holds Item No. 24 in place.
28. Chain, 10,000-lb capacity, FSN 1670-516-8405 (2 ea.), with Connecting Device, FSN 1670-212-1149.
29. Double G-11 Clevis. On test No. 3, tied to Item No. 14 with one turn of 550-lb BS nylon cord (FSN 4020-240-2146). On tests No. 4 through 8, break tie not used.

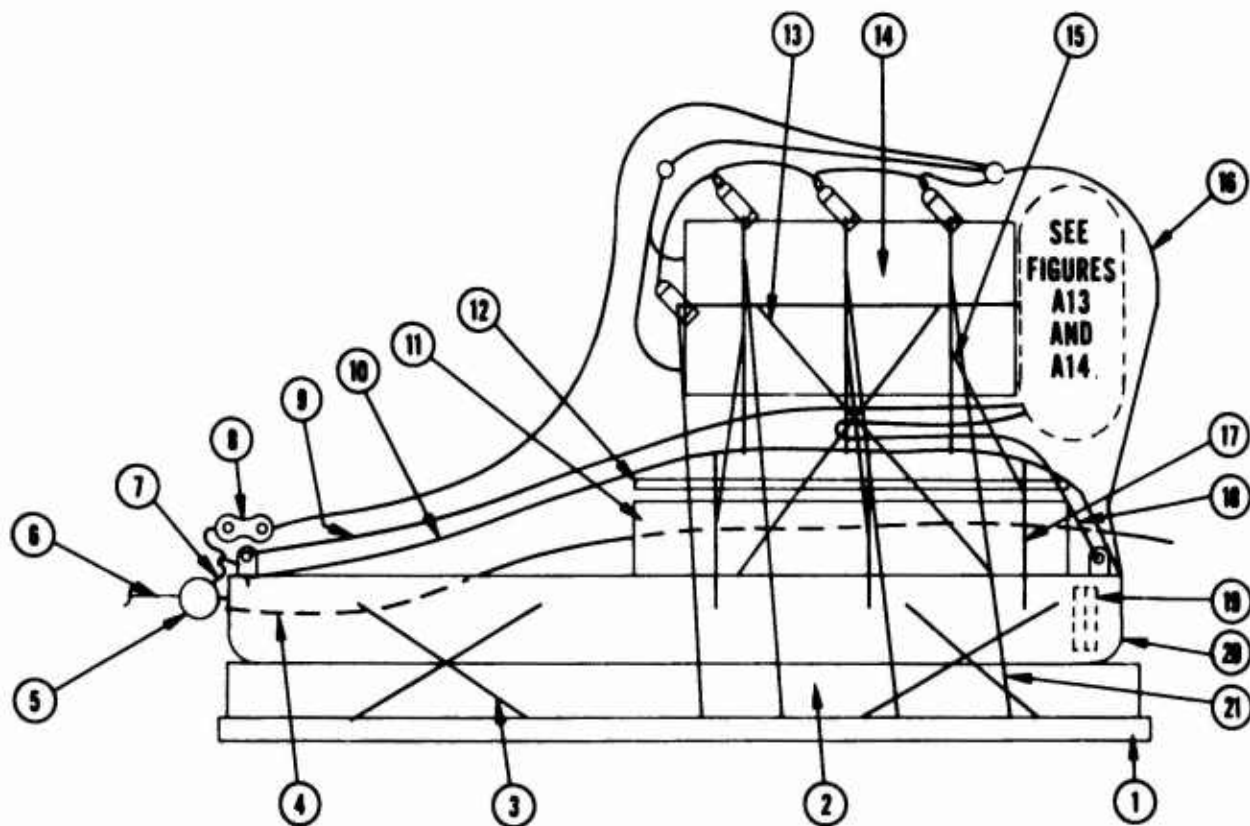

1. Type II Army Modular Platform, 12-ft, FSN 1670-893-1624 and 1670-893-1626.
2. Paper Honeycomb, 3 layers, FSN 1670-753-3928.
3. Tiedown Chains, 10,000-lb capacity (FSN 1670-516-8405) with Connecting Device (FSN 1670-212-1149), eight forward and eight aft.
4. CBS Cutter Activating Lanyard (2 ea.), 1000-lb BS nylon webbing, FSN 8305-082-5752, tied to floor of aircraft.
5. Force Transfer Device.
6. Extraction Line.
7. Recovery Parachute Deployment Line, tied to Item No. 20 in a minimum of two places with 350-lb BS cotton webbing (FSN 8305-263-3616).
8. Open Link Safety Device (go-no-go), tied to Item No. 20 in six places with one turn of 550-lb BS nylon cord (FSN 4020-240-2146).
9. Aft Load Suspension Sling (2 ea.), webbing covered with 2-1/2-in. fire hose, strain link and clevis covered with 6-in. fire hose.
10. Chain, 10,000-lb capacity, FSN 1670-516-8405 (2 ea.), with Connecting Device (FSN 1670-212-1149).
11. Paper Honeycomb, 3 layers, FSN 1670-753-3928.
12. Plywood, 3/4-in. thick, 4 ft X 4 ft.
13. Recovery Parachute Forward/Aft Restraint Tie, 6000-lb BS nylon webbing, FSN 8305-682-6803.
14. Recovery Parachute with Deployment Bag (3 ea.).
15. Recovery Parachute Lateral Restraint Tie (3 ea.), 6000-lb BS nylon webbing, FSN 8305-682-6803.
16. Break Tie. On Test No. 9 through 11, two strands 350-lb BS cotton webbing, FSN 8305-263-3616. On Test No. 12 and 13, two strands 1000-lb BS nylon webbing, FSN 8305-082-5752. On Test No. 14, two strands 4000-lb BS nylon webbing, FSN 8305-082-5753. On Test No. 15 through 18, two strands 6000-lb BS nylon webbing, FSN 8305-682-6803.
17. Chain, 10,000-lb capacity, FSN 1670-516-8405 (3 ea.), with Connecting Device, FSN 1670-212-1149.
18. Forward Load Suspension Sling (2 ea.), webbing covered with 2-1/2-in. fire hose, strain link and clevis covered with 6-in. fire hose.
19. Weight Test Platform Ballast, 6511th Dwg. No. 58D1043, put in forward-most slots of Item No. 20.
20. Weight-Test Platform. On Test No. 9, 10, 13 through 18, 12-ft, 6511th Dwg. No. 68E1492. On Test No. 11 and 12, 8-ft, 6511th Dwg. No. 68E1474.
21. Not used on Test No. 9 through 16. On Test No. 17 and 18, Bungee Cord, 3/16-in., FSN 8305-267-3116 (8 ea.).

Figure A12. Rigging Method C Used on Test Item Configuration II, Tests No. 9 through 18.

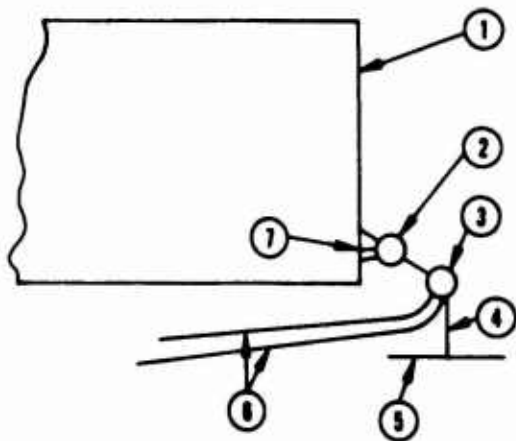

- 1 Recovery Parachute Deployment Bag.
- 2 Recovery Parachute Confluence Clevis.
- 3 Suspension Sling Confluence Clevis.
- 4 Break Tie, two strands 550-lb BS nylon cord, FSN 4050-240-2146.
- 5 Pedestal Restraint Chain.
- 6 Load Suspension Slings (4 ea.).
- 7 3-ft Recovery Parachute Attachment Slings (3 ea.).

Figure A13. Suspension Sling Confluence Point Break Tie Used on Rigging Method C, Tests No. 9 and 10.

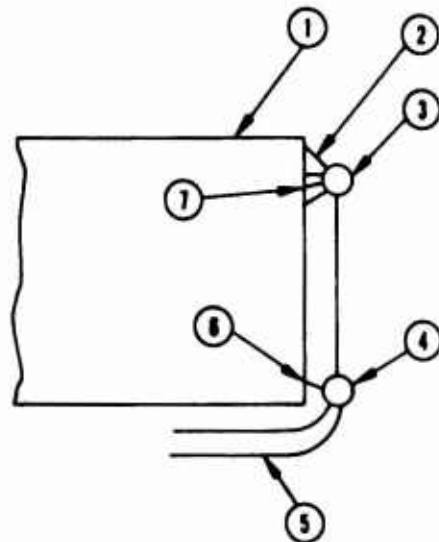

- 1 Recovery Parachute Deployment Bag.
- 2 Break Tie. On Test No. 11, 350-lb BS cotton webbing, FSN 8305-263-3616 (2 ea.). On Test No. 12, 1000-lb BS nylon webbing, FSN 8305-082-5752 (3 ea.). On Test No. 13 through 19, 550-lb BS nylon cord, FSN 4050-240-2146 (3 ea.).
- 3 Recovery Parachute Confluence Clevis.
- 4 Suspension Sling Confluence Clevis.
- 5 Load Suspension Slings, (4 ea.).
- 6 Same as Item No. 2.
- 7 3-ft Recovery Parachute Attachment Slings (3 ea.).

Figure A14. Suspension Sling Confluence Point Break Tie Used on Rigging Method C, Test No. 11 through 18 and on Rigging Method D, Test No. 19.

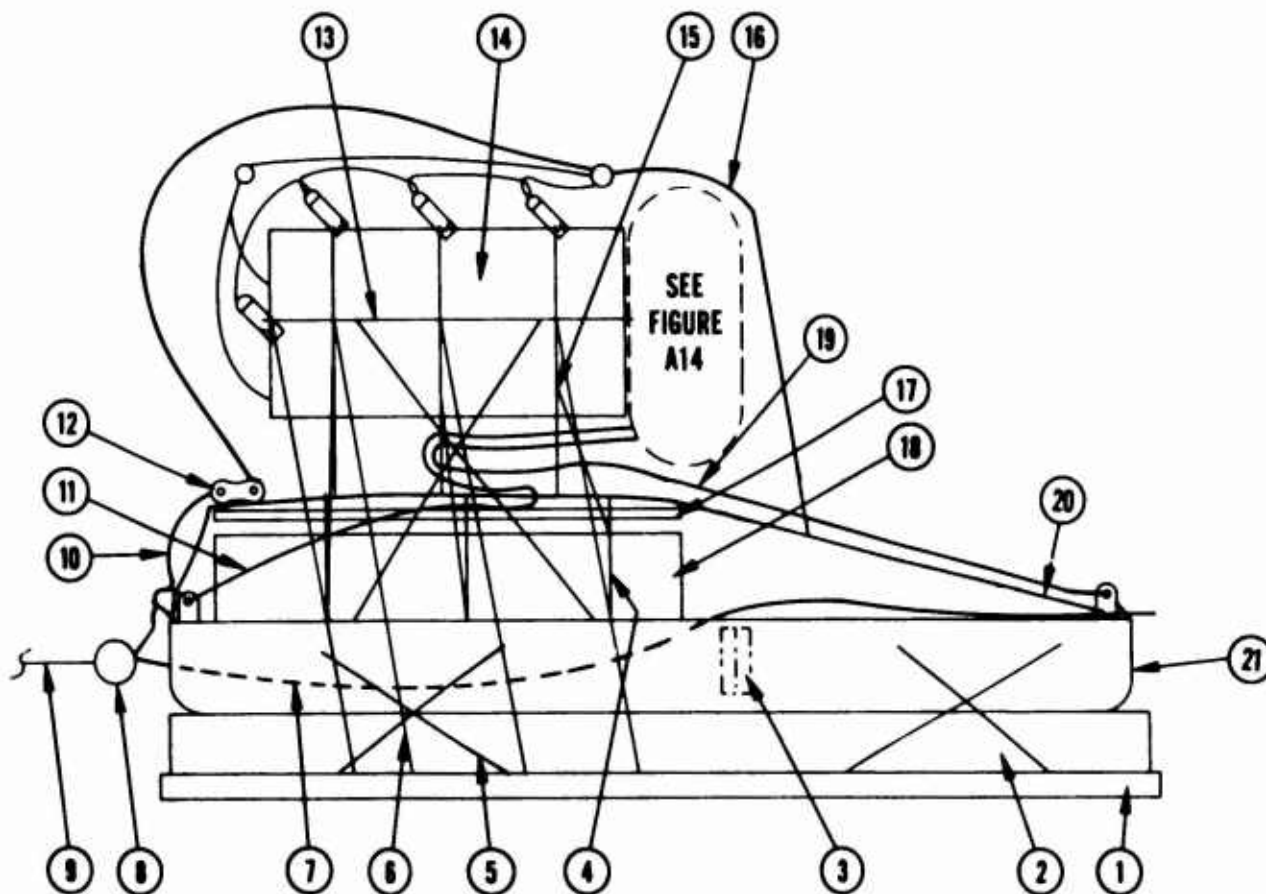

1. Type II Army Modular Platform, 12-ft, FSN 1670-893-1624 and 1670-893-1626.
2. Paper Honeycomb, 3 layers, FSN 1670-753-3928.
3. Ballast, placed in slot No. 15 through 25 of Item No. 21.
4. Chain, 10,000-lb capacity, FSN 1670-516-8405 (3 ea.), with Connecting Device (FSN 1670-212-1149).
5. Tiedown Chains, same as Item No. 4, eight forward and eight aft.
6. Bungee Cord, 3/16-in., FSN 8305-267-3116 (8 ea.).
7. CBS Cutter Activating Lanyard, 1000-lb BS nylon webbing, FSN 8305-082-5752 (2 ea.), tied to floor of aircraft.
8. Force Transfer Device.
9. Extraction Line.
10. Recovery Parachute Deployment Line, tied to Item No. 20 in a minimum of two places with 350-lb BS cotton webbing (FSN 8305-263-3616).
11. Aft Load Suspension Sling (2 ea.), webbing covered with 2-1/2-in. fire hose, strain link and clevis covered with 6-in. fire hose.
12. Open Link Safety Device (go-no-go), tied to Item No. 17 in six places with one turn of 550-lb BS nylon cord (FSN 4020-240-2146).
13. Recovery Parachute Forward/Aft Restraint Tie, 6000-lb BS nylon webbing, FSN 8305-682-6803.
14. Recovery Parachute with Deployment Bag, (3 ea.).
15. Recovery Parachute Lateral Restraint Tie (3 ea.), 6000-lb BS nylon webbing, FSN 8305-682-6803.
16. Break Tie, 2 strands of 350-lb BS cotton webbing, FSN 8305-263-3616.
17. Plywood, 3/4-in. thick, 4 ft X 4 ft.
18. Paper Honeycomb, 3 layers, FSN 1670-753-3928.
19. Forward Load Suspension Sling (2 ea.), webbing covered with 2-1/2-in. fire hose, strain link and clevis covered with 6-in. fire hose.
20. Chain, 10,000-lb capacity, FSN 1670-516-8405, (2 ea.), with Connecting Device (FSN 1670-212-1149).
21. Weight-Test Platform, 12-ft, 6511th Dwg. No. 68E1492.

Figure A15. Rigging Method D Used on Test Item Configuration II, Test No. 19.

Appendix B

INDIVIDUAL TEST RESULTS AND TEST ITEM DEVELOPMENT

Test No. 1: This load (Configuration I, Rigging Method A) was an uninstrumented load. The first stage load oscillation was marginal. Rotation of the load to the horizontal was achieved by the force exerted on the platform through the suspension slings. The load was recovered.

Test No. 2: This load (Configuration I, Rigging Method A) was an instrumented load. The first stage load oscillation was excessive. Rotation of the load to the horizontal was achieved by the force exerted on the platform through the suspension slings. The load was recovered.

Test No. 3: To reduce the first stage load oscillation, the recovery parachute was mounted on the forward end of the weight-test platform (Configuration I, Rigging Method B). This moved the load center of gravity forward. The first stage load oscillation improved but was still unacceptable. The strain link electrical leads to the recovery parachute and the vent pulldown line were cut on recovery parachute deployment and the force data were lost. Rotation of the load to the horizontal was achieved by the force exerted on the platform through the suspension slings. The load was recovered.

Test No. 4: To protect the strain link electrical leads, the break tie connecting the load suspension sling confluence to the weight-test platform was eliminated on this load (Configuration I, Rigging Method B). The load suspension slings were thus extended as the recovery parachutes were first deployed so that the electrical leads were protected from contact with the load by the fire hose padding. Ballast was placed in the forward end of the weight-test platform to increase the load weight and move the load center-of-gravity farther forward. The first stage load oscillation improved but was still marginal. The break tie provided satisfactory horizontal load rotation. The load was recovered.

Test No. 5: This load (Configuration I, Rigging Method B) had a larger 8-ft weight-test platform with longer load suspension slings mounted on a 12-ft load-bearing platform. To keep the load center-of-gravity forward, the front edge of the weight-test platform was even with the front edge of the load-bearing platform. No oscillation was observed during first-stage descent. Rotation of the load to the horizontal was achieved by the force exerted on the platform through the suspension slings. The load was recovered.

Test No. 6: For this load (Configuration I, Rigging Method B), the weight-test platform was centered longitudinally on the load-bearing platform. The first stage load oscillation on this test was excessive and the force transfer device failed to release the extraction/stabilization parachute. The load was destroyed on ground im-

pact. The probable cause of the force transfer device malfunction was the excessive oscillation which damaged the actuator cable.

Test No. 7: This load was rigged similarly to the load used on No. 5 to reduce the first-stage load oscillation. However, the force transfer device was a guillotine knife system (Configuration I, Rigging Method B), which it was thought would be capable of withstanding excessive load oscillation. The first stage load oscillation was improved but still marginal. The break tie provided satisfactory horizontal load rotation. The load was recovered.

Test No. 8: This load (Configuration I, Rigging Method B) consisted of a 12-ft weight-test platform mounted on a 12-ft load-bearing platform. This necessitated the use of longer load suspension slings. The first stage load oscillation was minimal. Rotation of the load to the horizontal was achieved by the force exerted on the platform through the suspension slings. The load was recovered. The recovery parachute suffered damage on opening. Due to damage incurred during this test, testing on the single recovery parachute system was terminated.

Test No. 9: Three recovery parachutes were used on this test load (Configuration II, Rigging Method C). A break-tie was installed between the load suspension sling confluence and the weight-test platform. Slings did not extend until the recovery parachutes were deployed. The first stage load oscillation was minimal. Rotation of the load to the horizontal was achieved by the force exerted on the platform through the suspension slings. The load was recovered. The strain link, which was installed to measure total recovery parachute force, was subjected to torsion because of its method of installation. This invalidated these force data measurements.

Test No. 10: This load (Configuration II, Rigging Method C) was identical to Test No. 9. The load suspension slings did not extend until the recovery parachutes were deployed and one strain link electrical lead was cut when the confluence area contacted the load. The electrical lead shorted out the entire strain link system power source and all force data were lost. The first stage load oscillation was marginal. Rotation of the load to the horizontal was achieved by the force exerted on the platform through the suspension slings. The load was recovered.

Test No. 11: This load (Configuration II, Rigging Method C) consisted of an 8-ft weight-test platform mounted on a 12-ft load-bearing platform. To keep the load center-of-gravity forward, the front edge of the weight-test platform was even with the front edge of the load-bearing platform. A webbing sling was used to protect

the recovery parachute total force strain link from torsion. To provide load suspension sling extension on recovery parachute deployment, a break was used between the sling confluence point and the recovery parachute deployment bags. The early suspension sling extension was intended to protect the strain link electrical leads from contact with the platform. On recovery parachute deployment, the confluence prematurely broke from the deployment bags. The first stage load oscillation was unacceptable. Rotation of the load to the horizontal was achieved by the force exerted on the platform through the suspension slings. The load was recovered.

Test No. 12: This load (Configuration II, Rigging Method C) was similar to the load used on Test No. 11 except that the break tie running from the sling confluence point to the deployment bags was strengthened to prevent premature breakage. The suspension slings extended properly on recovery parachute deployment. The first stage load oscillation was minimal. Rotation of the load to the horizontal was achieved by the force exerted on the platform through the suspension slings. The load was recovered.

Test No. 13: This load (Configuration II, Rigging Method C) consisted of a 12-ft weight-test platform running the full length of a 12-ft load-bearing platform. The first stage load oscillation was marginal. Rotation of the load to the horizontal was achieved by the force exerted on the platform through the suspension slings. The load was recovered.

Test No. 14: This load (Configuration II, Rigging Method C) was rigged similar to the load used on Test No. 13. The first stage load oscillation was minimal. Rotation of the load to the horizontal was achieved by the force exerted on the platform through the suspension slings. The load was recovered.

Test No. 15: This load (Configuration II, Rigging Method C) was rigged similar to the load used on Test No. 13. The first stage load oscillation was minimal. Rotation of the load to the horizontal was achieved by the force exerted on the platform through the suspension slings. The load was recovered.

Test No. 16: This load (Configuration II, Rigging Method C) was rigged similar to the load used on Test No. 13 except that the sling in the total recovery parachute strain link system was strengthened because of the expected high forces. This sling tangled in a cut recovery parachute restraint tie on recovery parachute deployment. Because of this, several strain link electrical leads were damaged and the entire strain link system power source was shorted out. All force data were lost. The first stage load oscillation was minimal. The load was recovered. One recovery parachute was damaged on reefed opening and the bolt in the suspension sling confluence clevis was slightly bent.

Test No. 17: This load (Configuration II, Rigging Method C) was rigged similar to the load used on Test No. 16 except bungee cord was added to pull the recovery parachute ties out of the way when they were cut. This was done to prevent the ties from tangling with the strain link electrical leads. On recovery parachute deployment, one strain link electrical lead was cut and intermittently shorted out the entire strain link power source. Some force data were obtained. The first stage load oscillation was minimal. Rotation of the load to the horizontal was achieved by the force exerted on the platform through the suspension slings. The load was recovered. All three recovery parachutes incurred some damage on opening.

Test No. 18: This load (Configuration II, Rigging Method C) was rigged similarly to the load used on Test No. 17 except that the suspensor sling confluence clevis was altered to prevent the bolt from bending (Test No. 16). The instrumentation electrical pack was modified to isolate any strain link lead that might short out. The first stage load oscillation was minimal. Rotation of the load to the horizontal was achieved by the force exerted on the platform through the suspension slings. The load was recovered. All three recovery parachutes incurred damage on opening.

Test No. 19: The recovery parachutes for this load (Configuration II, Rigging Method D) were mounted on the aft end and the ballast was located in the center of the weight-test platform. This was done to place the load center-of-gravity in the center of the load to determine the cg effect on first stage load oscillation. The recovery parachute reefing lines were shortened to reduce the damage on opening. The first stage load oscillation was excessive. Rotation of the load to the horizontal was achieved by the force exerted on the platform through the suspension slings. The load was recovered. One recovery parachute was damaged slightly on opening.

GLOSSARY OF TERMS

CBS - Confined Ballistic System	A pyrotechnic cutter which is activated at the end of a preset time delay.
Extraction/Stabilization Parachute	A parachute which both extracts a platform-mounted airdrop load from an aircraft in flight and provides a stabilizing drag force during initial descent of the load.
Guillotine Knife Force Transfer	An extraction force release device for airdrop loads which contains a spring-powered knife which is driven against and cuts a shear web.
Load-Bearing Platform	A flat-bottomed platform with side rails which is designed to fit into an aircraft rail system and to support and restrain airdrop loads.
Open Link Safety Clevis (Go-No-Go)	A separable connecting link which is rigged to separate in the event of premature application of recovery parachute deployment force on an airdrop load.
Reefing Line	A line around the skirt of a parachute canopy which reduces the initial degree of parachute opening and thus reduces the drag force of the parachute.
Riser Extension	A webbing sling used between a load and a parachute confluence point to provide separation between the parachute and the load or between multiple parachutes.
Shear Tie	A tied webbing loop which is cut to release a force.
Shear Web	A stitched webbing connector which is cut to release a force.
Vent Pulldown Line	A line running from the apex of a parachute canopy to the confluence point; the apex is pulled down toward the canopy skirt to achieve faster opening times.
Weight-Test Platform	A flat bottomed welded steel container which is fitted with slots for ballast weights and attachments for suspension slings, restraints, and an extraction system.
35K Force Transfer Device	An extraction force release device for airdrop loads consisting of a mechanical release coupling which is actuated by a rotating arm and a push-pull cable.