

UNCLASSIFIED



AD NUMBER

AD-B023 625

NEW LIMITATION CHANGE

TO

DISTRIBUTION STATEMENT - A

Approved for Public Release; Distribution Unlimited.

LIMITATION CODE: 1

FROM

DISTRIBUTION STATEMENT - B

Distribution limited to U.S. Gov't. agencies only;
Proprietary Info. Other requests shall be referred
to **US Army Command & General Staff College**
Fort Leavenworth, KS 66027.

AUTHORITY

Mr. Ed Burgess, Archive Manager, U.S. Army Command
and General Staff College, Ft. Leavenworth, KS.
July 21, 1999.

THIS PAGE IS UNCLASSIFIED

SECURITY CLASSIFICATION OF THIS PAGE (When Data Entered)

REPORT DOCUMENTATION PAGE

READ INSTRUCTIONS
BEFORE COMPLETING FORM

1. REPORT NUMBER		2. GOVT ACCESSION NO.		3. RECIPIENT'S CATALOG NUMBER	
4. TITLE (and Subtitle) Stagnation and Change in Military Thought: The Evolution of American Field Artillery Doctrine, 1861-1905--An Example.		5. TYPE OF REPORT & PERIOD COVERED Final Report, 11 Jun 76		6. PERFORMING ORG. REPORT NUMBER	
7. AUTHOR(s) Nesmith, Vardell E. Jr., MAJ, USA		8. CONTRACT OR GRANT NUMBER(s)		9. PERFORMING ORGANIZATION NAME AND ADDRESS Student at the U.S. Army Command and General Staff College, Fort Leavenworth, Kansas 66027	
10. PROGRAM ELEMENT, PROJECT, TASK AREA & WORK UNIT NUMBERS		11. CONTROLLING OFFICE NAME AND ADDRESS U.S. Army Command and General Staff College ATTN: ATSW-SE		12. REPORT DATE 11 Jun 76	
13. NUMBER OF PAGES 371		14. MONITORING AGENCY NAME & ADDRESS (if different from Controlling Office) Vardell E. / Nesmith, Jr		15. SECURITY CLASS. (of this report) Unclassified	
15a. DECLASSIFICATION/DOWNGRADING SCHEDULE		16. DISTRIBUTION STATEMENT (of this Report) (Distribution limited to U.S. Government agencies only: Proprietary Information Other requests for this document must be referred to U.S. Army Command and General Staff College, Fort Leavenworth, Kansas 66027) 15 DEC 1977			
17. DISTRIBUTION STATEMENT (of the abstract entered in Block 20, if different from Report) 382 pgs					
18. SUPPLEMENTARY NOTES Master of Military Art and Science (MMAS) Thesis prepared at CGSC in partial fulfillment of the Masters Program requirements, U.S. Army Command and General Staff College, Fort Leavenworth, Kansas 66027.					
19. KEY WORDS (Continue on reverse side if necessary and identify by block number)					
20. ABSTRACT (Continue on reverse side if necessary and identify by block number) See reverse.					

ADB023625

FILE COPY

037 260

D D C
RECEIVED
DEC 15 1977
RECEIVED

Unclassified

SECURITY CLASSIFICATION OF THIS PAGE (When Data Entered)

It is a truism that when battle erupts among nations an advantage falls to the side that has best solved the problems of the last war. An increased advantage accrues to the efficient belligerent who can transcend contemporary military precepts through the evolution of a new, major doctrine. This study is an attempt to understand the process by which doctrine changes.

The vehicle for the investigation is the evolution of American field artillery doctrine from 1861 to 1905. The study looks at the evolution of field artillery doctrine between two distinct concepts of employment--or paradigms--that of direct fire and that of indirect fire. At the time of the American Civil War, the predominant concept of employment was the direct-fire mode. Within a short time after the Russo-Japanese War, 1904-1905, the concept of indirect fire had supplanted the earlier paradigm.

The investigation reveals that in the evolution of a military doctrine, the tendency is to maintain the efficiency of the prevailing concept of employment, even though the concept may have inherent limitations in a changing battlefield environment; the progress of technology eventually permits a shift to a new doctrine, although the change is not likely to occur until it is provoked by an appropriate test of war.

ACCESSION for	
DTIC	WFO Section <input type="checkbox"/>
DDC	S&I Section <input checked="" type="checkbox"/>
...	...
...	...
INTEGRATION POINT OF ES	
...	
B	

Stagnation and Change in Military Thought: The Evolution of
American Field Artillery Doctrine, 1861-1905--An Example.

Vardell E. Nesmith, MAJ, USA
U.S. Army Command and General Staff College
Fort Leavenworth, Kansas 66027

Final Report 11 June 1976

Distribution limited to U.S. Government agencies only; 15 DEC 1977
proprietary information. Other requests for this document must be
referred to U.S. Army Command and General Staff College, ATTN: ATSW-SE,
Fort Leavenworth, Kansas 66027.

A Master of Military Art and Science thesis presented to the faculty of
the U.S. Army Command and General Staff College, Fort Leavenworth, Kansas
66027.

ABSTRACT

It is a truism that when battle erupts among nations an advantage falls to the side that has best solved the problems of the last war. An increased advantage accrues to the efficient belligerent who can transcend contemporary military precepts through the evolution of a new, major doctrine. This study is an attempt to understand the process by which doctrine changes.

The vehicle for the investigation is the evolution of American field artillery doctrine from 1861 to 1905. The study looks at the evolution of field artillery doctrine between two distinct concepts of employment--or paradigms--that of direct fire and that of indirect fire. At the time of the American Civil War, the predominant concept of employment was the direct-fire mode. Within a short time after the Russo-Japanese War, 1904-1905, the concept of indirect fire had supplanted the earlier paradigm.

The investigation reveals that in the evolution of a military doctrine, the tendency is to maintain the efficiency of the prevailing concept of employment, even though the concept may have inherent limitations in a changing battlefield environment; the progress of technology eventually permits a shift to a new doctrine, although the change is not likely to occur until it is provoked by an appropriate test of war.

STAGNATION AND CHANGE IN MILITARY THOUGHT: THE EVOLUTION
OF AMERICAN FIELD ARTILLERY DOCTRINE,
1861-1908--AN EXAMPLE

A thesis presented to the Faculty of the U.S. Army
Command and General Staff College in partial
fulfillment of the requirements of the
degree

MASTER OF MILITARY ART AND SCIENCE

by

V. E. NESMITH, MAJ, USA
B.S., United States Military Academy, 1966
M.A., Duke University, 1975

Fort Leavenworth, Kansas
1976

TABLE OF CONTENTS

	Page
LIST OF TABLES	iv
LIST OF FIGURES	v
INTRODUCTION	1
 Chapter	
I THE PROBLEM	5
II ANALYSIS OF THE PROBLEM	41
III THE POSTWAR ARTILLERY	66
IV THE NATURE OF THE PRINCIPAL AGENCY OF CHANGE	79
V 1870-1874: SCATTERED SEEDS OF TECHNOLOGICAL CHANGE.	111
VI 1875-1880: A SLOW GATHERING OF TECHNOLOGICAL MOMENTUM.	147
VII 1881-1888: FIRST MOTION IN THE DEVELOPMENT OF MOBILE ARTILLERY.	180
VIII 1889-1900: ACCELERATED DEVELOPMENT OF MOBILE ARTILLERY	211
IX 1901-1904: A TECHNOLOGICAL THRUST WITHIN THE DIRECT FIRE PARADIGM.	240
X A REVOLUTION IN THE CONCEPT OF FIELD ARTILLERY EMPLOYMENT.	267
CONCLUSIONS	287
NOTES	296
BIBLIOGRAPHY	354

LIST OF TABLES

Table	Page
1. Service Artillery in the Inventory of the U.S. Army, 1868.	69
2. Summary of Union Heavy Artillery Burst During the War	86
3. Weapons Selected for Test by the Board on Heavy Cannon, 1872.	123
4. Designs Recommended for Test by the 1873 Board on Gun-Carriages	130
5. U.S. Army Artillery Classified as Standard as of 1880.	174
6. Weapons Recommended by the Getty Board, 1882 . .	184
7. Competitive Test of Field Artillery Materiel, 1902.	256
8. General Staff Recommendation for the Organization of the Field Artillery, 1912	284

LIST OF FIGURES

Figure	Page
1. Civil War Field Artillery and Carriage	16
2. Direct and Indirect Firing Sites	45
3. Artillery Fire and the Trench.	47
4. Projectile Impact.	48
5. Manifestations of the Concept.	60
6. The Paradigm and the Interactions of Factors . .	63
7. Mounted Battery in Oblique March	75
8. Two Breech Designs Submitted to the Board on Heavy Cannon, 1872	124
9. 15-Inch Carriage with Two Air Cylinders.	129
10. Moffatt Breech-Loading Field Piece	134
11. 10-Inch Carriage with Hydraulic Recoil Check . .	149
12. Sutcliffe Breech-Loading Field Piece	153
13. Englehardt Field Carriage.	156
14. Two European Siege Weapons	157
15. 3-Inch, Muzzle-Loading, Chambered Rifle.	169
16. Hotchkiss Revolving Cannon, 1.5-Inch	172
17. Field Gun Modified with Sliding-Block Breech . .	190
18. Interrupted-Screw Breech	192
19. 3.2-Inch, Breech-Loading, Steel Field Gun. . . .	194
20. Field Carriage with Spring Recoil Brake.	196
21. Brisben's Shell for High Explosive	198
22. Steel, Breechloading, Siege Materiel	202

LIST OF FIGURES-Continued

Figure	Page
23. 3.6-Inch Mortar.	213
24. Sights for the 7-Inch Howitzer	214
25. 5-Inch Carriage with Hydraulic Buffer.	215
26. 7-Inch Carriage with Recoil Cylinder	217
27. Driggs-Schroeder Gun on Fixed Mount.	221
28. Armstrong 4.72-Inch Rapid-Fire Gun and Mount . .	222
29. Proposed System of Centralized Fire Control for Coast Defense, 1896.	231
30. French 75-Millimeter Field Gun	249
31. 3-Inch Field Gun	258
32. Panoramic Sight.	260

INTRODUCTION

This study is an attempt to understand the process by which military doctrine changes. It is concerned with shifts in attitudes about the proper employment of combat power. The term "doctrine" itself is ambiguous; it can be applied to concepts that range from finely drawn specific rules to broad generalizations. Principally, this paper is concerned with doctrine in a broad sense, although it does touch upon underlying specifics.

Doctrine is a strange phenomenon. It appears to respond to the dynamics of thought, and yet, at the same time it seems to clutch and direct thought, as if to insure its own ultimate survival. This is particularly true of doctrine in the broadest sense--doctrine that is shared by many practitioners.

In an effort to understand the phenomenon, the evolution of American field artillery doctrine has been chosen as a vehicle for the study. Consistent with the attempt to look at doctrine in its broadest sense, the study is focused upon what can be called the "concept of employment of field artillery." The study is an historical analysis; it looks at the evolution of field artillery doctrine between two distinct concepts of employment--or paradigms--that of direct fire and that of indirect fire. As a brief statement, direct fire was characterized by line-of-sight, low trajectory engagement of targets at relatively short ranges. In contrast, indirect fire featured massive, long-range, high-angle bombardment by weapons hidden from the view of

the enemy. At the time of the American Civil War, the predominant concept of employment of field artillery was the direct-fire mode. Within a short period after the Russo-Japanese War, 1904-1905, it can be said that the concept of indirect fire had supplanted the earlier paradigm. The intervening years were a period in which a multitude of factors combined at various times and in various strengths to prepare the way for the new doctrine.

The thesis is that, in the evolution of a military doctrine, the tendency is to maintain the efficiency of the prevailing concept of employment, even though the concept may have inherent limitations in a changing battlefield environment; the progress of technology eventually permits a shift to a new concept of employment, although the change is not likely to occur until it is provoked by an appropriate test of war.

Specifically, this study deals with field artillery doctrine. It shows that the introduction of the rifle and the subsequent use of the trench reduced the efficiency of direct-fire artillery. The evolution between the concepts of the direct- and indirect-fire employment of field artillery was the product of many factors, among which, the status of technology, as it related to mobile artillery, was the most important. The persistence of the old concept constrained the evolution, which resulted in attempts to maintain the efficiency of direct fire in a changing battlefield environment, although the doctrine was inherently incapable of solving the problem posed by the rifle and the trench. At the same time, and to some extent, without deliberate intent, the technology necessary for a system of indirect fire developed. A test of war eventually invited a recognition of the potential of

available technology. It was not just any war, but it was the right war at the right time. The subsequent change to a new concept of indirect fire was rapid to the point of being revolutionary.

The study is complex, because the process of change was a many faceted phenomenon. In fact, the reader may be disturbed by the wide range of subjects brought into the analysis. But the effort would be neither complete nor a fair portrayal of the process of evolution unless a conscientious attempt were made to cast the net of inquiry in a wide pattern, in order to capture all of the significant nuances of change.

Of course, there are hazards in any attempt to extract lessons from the past that might have relevance today. It is easy to dismiss the period chosen for this study as one in which the American Army existed in a parochial environment, without the benefit of the sophisticated approaches to problem solving that characterize the modern military institution. In general, there is some validity to the foregoing observation; however, human nature changes little, and it is this consistency that gives worth to any historical analysis.

The reader is cautioned that this analysis is based on the American experience. In tracing the pattern of the evolution, an attempt has been made to use material that was available to American planners during the period. European achievements are generally featured in two ways: to show the germination of pertinent ideas, and to demonstrate the effect of certain foreign concepts on American attitudes. A researcher more familiar than this writer with the progress of artillery employment in any particular European nation may argue that the concept of indirect fire was born there prior to the Russo-Japanese War. This

may be. Nevertheless, this study is based on American perceptions; and in the American experience, the Russo-Japanese War was the transition point.

The purpose of this study is to extract lessons on doctrinal change that may be useful to today's military planners. The first ten chapters trace the evolution of artillery doctrine; the final chapter outlines the lessons to be learned about doctrinal change. It is a truism to say that when battle erupts among nations an advantage falls to the side that has best solved the problems of the last war. An increased advantage accrues to the efficient belligerent who can transcend contemporary military precepts through the evolution of a new, major doctrine. The degree of advantage is not fixed, but it can be significant, as it was with blitzkrieg tactics at the beginning of World War II. Of course, with sufficient resiliency the disadvantaged side can overcome the initial superiority of its opponent by adopting the same or an improved doctrine. But the wisest course is to strive for the initial advantage. It is intended that this thesis will provide, in at least some small way, increased insight into the process by which combat doctrine evolves.

CHAPTER I

THE PROBLEM

In the days when cannons could outrange the short fire of muskets, Napoleon would mass his highly mobile artillery forward of his lines of infantry, and with relative impunity from enemy small arms batter the opposing line with direct fire. At the right moment he would pass his infantry through his guns and carry the position with the bayonet.

The French emperor depended heavily on his artillery. His battles opened with the sound of guns from the divisions, soon followed by those of the corps. Before he launched his main attack, the greater part of his army artillery reserve would rush to the front. An intensive bombardment would pulverize the opposing line at the point of assault. If fortune handed Napoleon the right to pursue a broken enemy, his horse artillery supported the cavalry. If fate withheld its favor, then artillerymen delayed to cover the army's withdrawal.¹ The importance of field guns on the Napoleonic battlefield was a derivative of their range advantage over infantry muskets. Napoleon heightened the advantage by an aggressively mobile exploitation of his artillery arm.

Canister fire was most deadly against exposed infantry. Gunners² could use canister at ranges as great as 600 meters; however, its effectiveness increased as the distance diminished. In contrast, at³ ranges beyond 250 meters the infantry musket was nearly useless.

Napoleon's artillery would often unlimber within 500 meters of

4
 the enemy. As long as it remained beyond the reach of musket fire it could dominate the battlefield. Of course, battle was never as neat as these finely drawn distances might suggest; enemy artillery could reach the offensive cannons; and only heavy canister fire could insure that defending infantry or cavalry would not advance to overrun the guns. In addition, in their enthusiasm, artillery commanders would sometimes ignore the danger of musket fire. For instance, at Friedland, Brigadier General Alexandre-Antoine de Serrarmont aggressively endured a hail of fire, while advancing his batteries to within 100 meters or so of the Russian lines.
 5

Napoleonic methods were powerful examples. They attracted military minds for half a century. In the Mexican War, the American artillery did not begin to approach the mass employed by Napoleon, but the audacious spirit was there. In the 1853 edition of his classic manual, Out-Post, Dennis Hart Mahan wrote about American gunners:

The artillery, . . . , has of late years begun to infuse a dash of dare-devil spirit of the cavalier into its ranks. If it has not yet taken to charging literally, it has, on some recent occasions in our service, shown well-considered recklessness of obstacles and dangers, fully borne out by justly deserved success Formerly, considered only in the light of an auxiliary on the battle-field, artillery now aspires, and with indisputable claims, to the rank of a principal arm. Its decisive effects, at the late battles on the Rio-Grande, are supported by testimony too emphatic to be overlooked.⁶

Direct fire was the prevailing style of field artillery engagement at the time of the Mexican War. In its basic form it was quite a simple concept--low-trajectory artillery was placed within range and line of sight of the target. The range limitation is obvious; but line of sight and low trajectory need explanation.

In the days of muskets and cannons it was not uncommon for armies to draw up within sight of each other and remain out of

engagement range. The line-of-sight coverage of battlefields varied between extremes, depending on foliage, variations in surface relief and the position of the observer. Of course, in choosing their ground, commanders tended to select positions that maximized their field of observation. The limited range of muskets meant that forces could be drawn up and battles fought well within such a distance. Cannons with a range advantage over muskets could dominate much of the battlefield. Target acquisition was no more complicated than observing the enemy from the guns and firing as ordered by commanders. Ranges were such that cannons could do their work with low-trajectory fire, unless the enemy hid himself behind the stout walls of a fort or within terrain defilade. In such cases, gunners needed fire with a higher angle of impact. But even then, the general target area, if not the enemy himself, was usually visible from the location of the artillery.

Unless an ungallant enemy hid himself, gunners preferred low-trajectory fire. Those artillery pieces that fired directly at the enemy were inherently more accurate than those that lobbed their projectiles in arched trajectories. The most obvious reason is that distance multiplies initial error in ballistic trajectories. Also, distance multiplies the effect of other error factors such as wind drift. Of course, accuracy with any smoothbore barrel was not exceptional. It was a relative advantage in accuracy that contributed to the popularity of low-trajectory weapons.

For many years, armies had maintained three types of artillery: guns, howitzers, and mortars. A gun had a relatively long barrel; it was designed to fire a projectile at a low trajectory to a distant target. The howitzer had a shorter barrel and less range. It was

capable of curved fire; therefore, it was handy for searching out gulleys and the back sides of ridges. The mortar had the shortest barrel, the least range, and a high-angle capability that was useful for dropping shells behind the walls of forts. Of course, there were contradictions to the foregoing general comparison; for instance, a small gun might have less range than a large howitzer.

Each of the three types had its own trajectory characteristics. Guns were clearly low-trajectory weapons. The Model 1841, American 12-pounder, at 5 degrees elevation, fired a shot to 1,663 yards.⁷ On the other hand, mortars were clearly weapons for high-angle fire. The Model 1841, 8-inch mortar, at 45 degrees, had a range of 1,200 yards.⁸ The howitzer is a bit more difficult to describe. It was capable of curved fire, but this was only partially the result of the elevation of the barrel. The Model 1841, 2-pounder howitzer fired at an elevation of only 5 degrees to its maximum range of 1,072 yards. The heavy 8-inch siege howitzer of the same year reached its full range of 2,614 yards at an elevation of only 12 1/2 degrees.⁹ As can be seen, the elevation of the howitzer did not vary much from that of the gun. To a great extent, the curved fire of the howitzer was a result of the reduced size of its powder chamber and hence its smaller propelling charge. The 12-pounder howitzer used .75 pounds of powder at full range compared with 2.5 pounds for the gun of the same caliber.¹⁰ The lower charge of the howitzer shortened its range and contributed to an increased angle of projectile impact.

Accuracy was one consideration for maintaining a low-trajectory; another was the effect of recoil on the carriage. As a muzzle was raised, the force of recoil was increasingly directed downward through

the carriage rather than backward. Wheeled wooden carriages could not stand great downward recoil strain. This was no problem with mortars, for they were set directly on the ground for firing. The point is that howitzers, like guns, were essentially low-trajectory weapons.

In fact, howitzers were often valued as much for the burst effect of their relatively large-caliber ammunition as they were for their ability to probe defilade areas. Because of their shorter barrels, howitzers weighed much less than guns of the same bore diameter. As a result, field batteries often contained howitzers in larger calibers than guns. For instance, in 1846, field batteries were authorized four 6-pounder guns (Model 1841, 884 pounds) and two 12-pounder howitzers (Model 1841, 788 pounds).¹¹

American artillerymen used howitzers and guns in their field batteries; mortars were left with the heavier siege, garrison, and sea-coast weapons. Mortars and larger pieces of artillery were auxiliaries in field service. They were called forward only for special siege operations.

With the start of the Civil War, the romance of the bouncing light artillery piece, rushed by mounted gunners to fire here and there between approaching lines of infantry, was cooled by the deadly fire of the rifle. By the fall 1862, many units on both sides were equipped with rifles.¹² Artillerymen could no longer dash between the lines with impunity; field guns were brought back to the line of infantry. Even infantry tactics were altered as men instinctively sought cover against the deadly accurate rifle bullet. Trenches eventually became the common form of defense, and the mass attack became costly.

When the war began, there was already a sufficient number of

rifles in the hands of the belligerents to make an impact on the battlefield. In the decade before the war, the United States Army had adopted the Minie ball. The new ammunition made the rifle a practical infantry weapon. As of January 1861, there were 77,346 rifles in government arsenals. Some were held in the South, and they fell into the possession of the seceding states. Agents from both North and South soon hurried abroad to buy more.

13

The effect of the rifle was that it swept much, if not all, of the line-of-sight area of a battlefield. Like line of sight, the extent and the conformation of the zone of fire would vary from location to location, depending upon the position of the riflemen, foliage, and undulations in the ground; the zone of fire defies a precise, universal measurement. Estimations of the effective range of Civil War rifles vary from source to source, but 500 yards for the standard infantry weapon and a somewhat greater distance for a sniper's piece seem to be adequate figures for generalizations about the rifle's impact.

14

The range of the rifle twice restricted the employment of field artillery. First, since the great majority of artillery depended on both visual acquisition of a target and low-trajectory engagement, it was restricted to the line-of-sight zone around the intended target area. Enemy rifle fire from the target area could dominate much of the zone and thereby reduce the number of potential firing sites for artillery pieces. Second, and more important, in driving the artillery back toward the far edge of the line-of-sight area, the effect of canister, so deadly against infantry at close range was substantially reduced. Within its range, canister was more effective than any other round against infantry. Beyond that distance, artillerists had to turn

to ammunition which could reach farther but that was less effective:
 15
 solid shot, shell, or case. Of course, cannoners could ignore rifle
 fire and push their pieces forward into canister range, but the penalty
 for such bravery was high.

The rifle, however, did more than drive the artillery back. Its
 accurate long-range fire caused the infantry to seek the protection of
 field fortifications. The idea of field fortifications was not new to
 the American Army. On many occasions, from Breed's Hill in 1775 through
 Chapultepec in 1847, the Army had either defended or attacked field works.
 The battles of Yorktown, New Orleans, and Cerro Gordo are three better
 known examples. The dean of West Point instructors, Dennis Mahan, had
 urged the use of defensive works in his 1836 publication, A Complete
Treatise on Field Fortifications. Mahan saw them as a means to offset
 the disadvantage of a relative lack of training among militiamen when
 16
 they were faced with a disciplined enemy. He was no doubt influenced
 by Andrew Jackson's success at New Orleans. Mahan's field fortifica-
 tions were elaborate structures that took time to prepare. They
 featured an above ground parapet protected by a wide ditch. Mahan
 described his field works with the nomenclature associated with the
 military architecture of permanent places of defense; he used terms
 17
 such as, "exterior slope," "banquette," and "counterscarp." His
 concept of field works was similar to the elaborate and well thought-
 out defenses that had occupied the talents of military engineers for
 three centuries.

Mahan also advised the use of hasty fortifications when troops
 were beyond the main line of defense. Skirmishers were to fell trees
 and align them with their branches pointing toward the enemy on the

more accessible avenues of attack. Such an obstacle was called an "abatis." The defenders could strengthen the obstacle by digging a ditch behind it, and by erecting behind that, a slight parapet.

An important consideration in the construction of field fortifications during the musket era was the need to breakup the force of a bayonet assault. The short range of muskets permitted the enemy to get quite close without suffering the effects of small arms fire. And when the foe did get within range, the effect of defending muskets was restricted by their slow rate of fire. Armed with the same type of weapon, the attackers ultimately resorted to the shock effect of the bayonet charge, or at least the fear of it, to drive opponents from the field. It was to break up such charges that one resorted to the abatis, the ditch, and the parapet, if there was time to construct them. If there was not time, the common recourse was to be prepared to meet mass with mass--everyone on the field lined up, at close intervals, and ready.

The introduction of the rifle affected the use of field fortifications in two ways. First, the rifle encouraged the soldier to look for cover. With its increased effective range, it dominated much more of the battle field than the musket. But perhaps more important, it made the use of simple entrenchments practical. The increased killing range of the rifle could wear down an attack before it got close enough to become a bayonet assault. Also, it forced assaulting formations to open up to reduce casualties, which dispersed the mass so essential to the effective use of the bayonet. The need for the ditch and the parapet was greatly reduced. Where stone walls and sunken roads were not available, trenches or simple fighting holes could be used, which is not to say that the simple trench was suddenly discovered; it just

became more practical than it had been before the widespread adoption of the rifle. The shallow trench was useful as a field expedient, but in the first years of rifled small arms, most pieces still had to be loaded from the muzzle, which was devilishly hard to do from any but an upright position. And parapets did not entirely disappear; logs were often used by themselves or in conjunction with trenches to provide protection from projectiles. One can say then, that the rifle increased the soldier's need for cover, and at the same time, it offered him the chance to use a rather simplistic form of protection that had not really been practical during the age of the musket.

The use of the trench offered an added benefit; it provided protection from artillery. If the parapet was small, or not used, then there was little to invite the battering power of solid shot. Moreover, a hole sunk in the earth gave protection, both front and back, to the fragments thrown about by the air or ground bursts of cannon shell and case. In many ways, the trench was a practical adaption to the mid-nineteenth century battlefield.

During the course of the war, however, the use of the trench was by no means universal. A fence would provide some protection; a railway embankment or a sunken road would provide more. Even the edge of a woodline was better than standing in the open. A unit in defense might accept the security of natural cover, or choose to build its own protection. Trenches appeared early in the war, but they did not become a regular feature until 1863.¹⁹ From then until the end of the siege of Petersburg, both armies employed them with increasing frequency.

In brief review, the rifle had two principal effects on artillery. First, it drove the guns back away from the infantry target

and beyond canister range. Second, it caused the infantry to seek the shelter of field fortifications which further reduced the effect of artillery fire. The two changes significantly reduced the offensive potential of field pieces.

Rifling, however, was not limited to small arms; it was quickly adapted to artillery. Initially, in the emergency created by the onset of hostilities, Secretary of War Simon Cameron ordered the purchase of two hundred wrought-iron, rifled field pieces.²⁰ The order was sent to the Ordnance Department where plans for the gun were drawn by officers of the Ordnance Board. The contract was given to the Phoenix Iron Company of Phoenixville, Pennsylvania. John Griffen, who had pioneered the use of wrought iron in the construction of field pieces seven years earlier, had brought the firm into the gun making business; he became its superintendent. The weapon produced by the Phoenix Company was called the 3-inch Ordnance Rifle. The company made about fourteen hundred of the guns during the war.²¹ Robert Parrot, another civilian, who in 1860 designed a cast-iron gun, reinforced at the breech with wrought iron, also produced many cannons for the Union. His 10-pounder gun was well represented in numbers in field batteries.²² It was not a weapon of the highest quality, but it could be produced quickly and in quantity.²³ Again, the prewar initiative of a civilian entrepreneur was a valuable supplement to the weapons development capability of the Army. Other Parrott rifled guns saw Federal service. The 20-pounder, at 1750 pounds weight, was too heavy to be considered a field gun, but it was used in the Artillery Reserve.²⁴ The 30-pounder was a siege and garrison piece. Sea coast batteries contained calibers of 60-, 100-, 200-, and 300-pounders.²⁵ The Union artillery used guns of several

varieties; however, the most numerous rifled pieces with the field batteries were the 3-inch Ordnance Rifle and the 10-pounder Parrott,²⁶ figure 1.

Rifled artillery, however, did not completely replace the smooth-bore variety. Smoothbore guns in calibers of 6- and 12-pounder, and howitzers of 12, 24, and 32-pounder could be found in Union field²⁷ batteries.

In the Confederacy, the desire for rifled artillery was not as easily satisfied by the productive power of home industry; but supplements from importation and capture eventually provided the South with a sizeable artillery force. In the summer of 1860, Major Thomas Jackson, of the Virginia Military Institute, witnessed the test of a Parrott field gun. At his recommendation, Virginia purchased twelve. During the war, the Tredegar Foundry in Richmond produced many guns on the Parrott design. The South also produced a bronze 3-inch piece; but the Union Ordnance Rifle of the same size continued to be a highly valued trophy of Confederate gunners. At the start of the war, both sides rushed to buy arms in Europe. Once Northern production caught up with demand, foreign weapons could be put aside to simplify problems of ammunition supply. The South, however, imported weapons until the blockade choked the supply to a trickle. Among other types, the South purchased a number of English Whitworth 6- and 12-pounder rifles for use in the field. These were steel, breech-loading weapons--a relatively new and untried design--that fired solid shot exclusively, but with²⁸ great accuracy. The mixed collection of rifled cannons in both armies soon made an impact on the employment of field artillery in battle.

Increased range was one of the advantages of rifled cannons.

FIGURE 1
 CIVIL WAR FIELD ARTILLERY BARRELS AND CARRIAGE

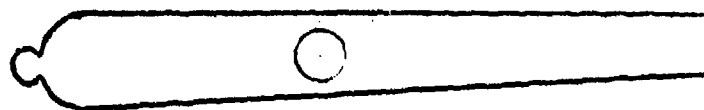

Ordnance 3-Inch Rifle

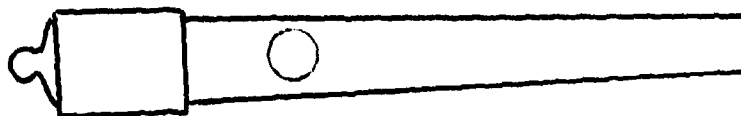

Parrott 10-Pounder Rifle

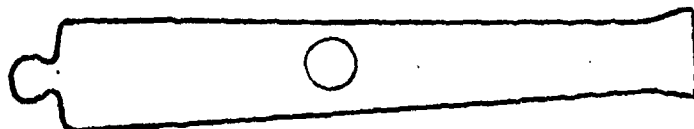

12-Pounder Smoothbore

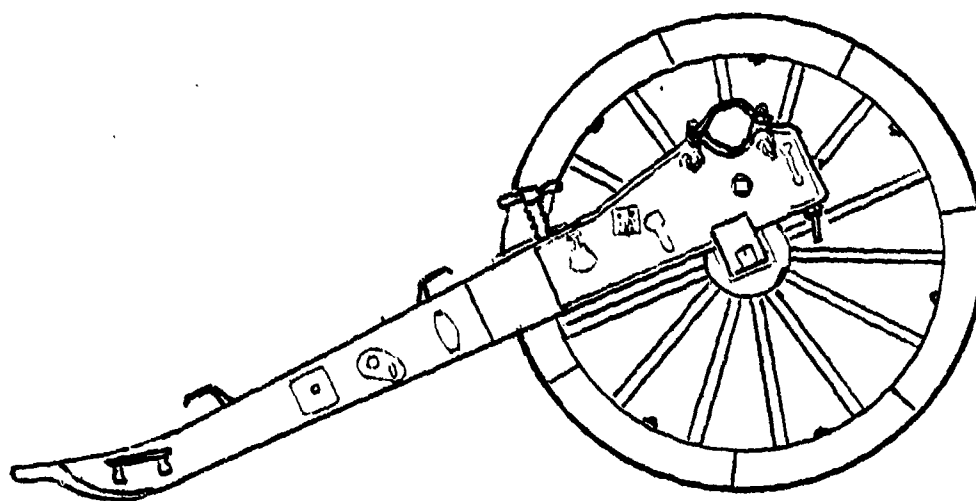

Carriage

SOURCES: Harold L. Peterson, Round Shot and Rammers (Harrisburg, Pennsylvania: Stackpole Books, 1969), pp. 93-94 (barrels); and Jack Coggins, Arms and Equipment of the Civil War (Garden City, N.Y.: Doubleday and Company, 1962), p. 66 (carriage).

The spin stabilization and the reduced air resistance of oblong projectiles added to the range of the new guns. For instance, the 3-inch Ordnance Rifle could fire a shell to 3,972 yards; the Model 1861 10-pounder Parrott could throw a shell to 5,000 yards; and the Whitworth 12-pounder could put a solid shot an amazing 10,000 yards away. In contrast, the smoothbore 12-pounder Napoleon had a maximum range of 1,680 yards with a solid shot. However, one must be careful with these raw statistics. In great part, the ranges can be attributed to the increased elevation capabilities that designers gave the newer carriages, which were respectively 20, 20, and 35 degrees for the Ordnance, Parrott, and Whitworth weapons. The maximum elevation for the older Napoleon was 5 degrees. At only 5 degrees, the range of the Ordnance Rifle was 1,830; the Parrott gun, 1,850; and the Whitworth, about 2,300 yards. Whereas, formerly artillerists had tended to avoid higher elevations in the design of field guns, the new technicians used the capability to give their weapons additional range.

Technological advances placed a "carrot" before ordnance engineers, and they tended to chase it with more concern for statistics than for practical value. The benefit of extreme long-range fire was questionable. When it exceeded the limit of the gunner's observation he could not judge the effect, nor could he adjust rounds that missed the unseen target. With the exception of a rare firing position from a high hill with an unobstructed view, or a siege engagement of a target both wide and deep, there was little practical use for extreme long-range fire in land warfare.

The impact of rifled artillery had a mixed effect. At lower elevations, and hence shorter ranges, rifled artillery was of some value

in the defense. Gunners could often engage advancing infantry at distances beyond the range of rifled muskets. But, once the novelty of rifled artillery wore off, gunners tended to prefer Napoleon smooth-bores. ³² The canister effect from the 4.62-inch bore of the Napoleon was still devastating in the final yards of an infantry assault.

A principal role for rifled artillery became counterbattery fire. It is ironic, however, that the increased range of the new guns assisted the soldier's rifle in driving field artillery back away from the infantry target. The important thing that rifling failed to do was to restore artillery to its former prominence in the attack. At ranges safe from small arm fire, gunners with rifled cannons did little damage to entrenched infantry.

The rifling of artillery did permit a significant advance in the design of ammunition. The size of a spherical shell was limited by the bore diameter of a cannon. In contrast, rifling permitted the use of oblong ammunition, which resulted in a greater projectile weight ³³ for a given caliber. Also, Ordnance engineers had long desired a shell that would explode immediately on impact; but the unstabilized flight of spherical ammunition made the design of an effective contact fuse extremely difficult. The stabilized flight of the rifled projectile removed some of the difficulty that had plagued earlier design efforts. Rifled ammunition could be reasonably depended upon to hit on one spot, the nose, which meant that a single fulminate of mercury cap could be used as a detonator. Also, it was relatively easy to protect the forward facing cap during loading and discharge, which made it bore safe by reducing the peril of a premature explosion within the cannon ³⁴ itself.

Of course the perfection of contact fuses took time. When the armies of the North and South clashed at the First Bull Run, the Confederate artilleryman Captain John D. Imboden noted that the rifled projectiles striking around his battery burrowed into the ground, before exploding rather harmlessly. After a hundred such shells had hit, he remarked that it looked as if the field had been rooted up by hogs.³⁵ It was a telling if perhaps deprecating comment about the imperfections of the new technology of rifled ordnance. But imperfections aside, rifling, particularly in small arms, was changing the nature of war.

After the indecisive clash at Manassass Junction, the Union Army began a serious expansion. Old concepts had to be reconciled with new considerations. An immediate problem was the organization of an unaccustomed mass of artillery. The practical experience of the Army was, of course, the Mexican War. Beyond that, its theoretical guidance was largely derived from the Napoleonic model.

In the Mexican War, field batteries were assigned to infantry formations of relatively small size. In Zachary Taylor's army, batteries were given to brigades. In Winfield Scott's force, they were assigned to divisions; but the divisions averaged only 2,400 men, which was less than a brigade in the new Union Army.³⁶ Also, neither force in the Mexican expedition maintained a field artillery reserve. The artillery that accompanied Union troops to Bull Run had been organized on the principles of the Mexican War. But the growing Union Army dwarfed the Mexican expedition, and as a result, it demanded other considerations in its organization.

The Napoleonic model was a ready reference for the organization of a large force. The French emperor placed artillery with his

divisions and with his corps. There were also periods in which guns were assigned down to the level of the regiment. In addition, he maintained a significant number of cannons in his artillery reserve. Napoleon's divisions contained two or more brigades, each of two or more regiments. At full strength, a regiment had 3,970 men. In the Napoleonic model, artillery could be found at all echelons from regiment to corps. Most important, roughly one-quarter of the French artillery was retained in an army reserve.

To organize the artillery of his growing army, General George B. McClellan summoned Major William F. Barry and appointed him to be his Chief of Artillery. Barry had served in the Artillery since 1838, and he was veteran of the Mexican War.

After his appointment as Chief of Artillery, Barry set about the task of establishing an organization for his arm within the Army of the Potomac. He laid down the following principles:

- "1st. That the proportion of artillery should be in the ratio of at least two and half pieces to 1,000 men, to be expanded if possible to three pieces to 1,000 men.
- "2dn. That the proportion of rifled guns should be restricted to the systems of the U.S. Ordnance Department, and of Parrott and the smoothbores (with the exception of a few howitzers for special service) to be exclusively the 12-pounder gun of the model of 1857, variously called the 'gun howitzer,' the 'light 12-pounder,' or the 'Napoleon.'
- "3rd. That each field battery should; if practical, be composed of six, and none to have less than four guns, and in all cases the guns of each battery to be of uniform caliber.
- "4th. That the field batteries were to be assigned to divisions and not to brigades and in the proportion of four to each division, of which one was to be a battery of regulars, the remainder of volunteers; the captain of the regular battery to be the commander of the artillery of the division. In the event of several divisions constituting an army corps, at least one-half of the divisional artillery was to constitute the reserve artillery of the corps.
- "5th. That the artillery reserve of the whole army should consist of 100 guns, and should comprise, besides a sufficient number of light mounted batteries, all of the guns of position, and until the cavalry was massed all the horse artillery.
- "6th. That the amount of ammunition to accompany the field batteries

was not to be less than 400 rounds per gun. 40
 "7th. A siege train of fifty pieces

41

McClellan approved Barry's proposals.

Before the Civil War, although others had ventured essays and manuals that contained generalities on the development of a large tactical field artillery force, apparently this was the first comprehensive American plan for such an organization. 42 The four peacetime artillery regiments, each with ten heavy and two light batteries, were primarily administrative organizations. 43 In addition, there was no echelon between the battery and the regiment. It was not a structure that was suitable for the development of a large field artillery force. Barry provided the needed plan. As the war progressed, some of the changes that were made to Barry's initial program reflected, to a large extent, a shifting concept in the employment of field artillery.

As Barry formulated his plan, he had to tackle the question of the proper organization of the artillery above the level of the battery. The prevailing attitude in the Army was that the proper unit of employment was the battery. 44 This worked well enough when only a few batteries took the field as they did in the Mexican War, but it was obvious that a far greater number would be employed in the coming campaign against the South. The problem was two-fold: first, several separate batteries complicated the supervisory responsibility of the supported unit; and second; the lack of formal command and staff positions beyond the level of the battery limited promotion opportunities for artillery officers. 45 The solution approved by McClellan called for the Regular Army battery commander to take charge of those batteries assigned to a division. This was in addition to his responsibilities to his own battery. The effect was that, with the exception of the

Artillery Reserve, the highest artillery command remained that of a captain. The problem of control was solved, but artillerymen resented what they saw as the lack of an adequate rank structure. Barry campaigned hard for increased command authority for his own office, but McClellan limited him to administrative functions. ⁴⁶ The Chief of Artillery's discontent with the rank structure of his organization was fueled by his perception that a battery of artillery was the equivalent ⁴⁷ of a battalion of infantry. Such an assertion was, of course, quite subjective and obviously based on firepower rather than manpower. But Barry's superiors did not necessarily disagree with the comparison. After Henry Halleck was called to the War Department to become Commanding General of the Army, in an exchange with McClellan, he referred to a battery as equivalent to a regiment. However, shortly thereafter, he ordered that artillery be taken into service as single batteries, ⁴⁸ making field grade officers and staffs unnecessary. Actually Halleck's words and actions were quite consistent. Since the regiment was the standard infantry unit called to the colors, its equivalent, the battery, would be the standard artillery unit. However, the assertion that field grade officers and staffs were unnecessary would be rendered invalid before the war passed its second year--provisional organizations would supply the need. But until the end of the war, and for many years thereafter, the battery would remain the highest organization for field artillery authorized by law.

Resistance within the Army to formalizing tactical organizations for the field artillery above the level of the battery was a complex phenomenon. Certainly there was some hesitance on the part of the Army establishment to create new organizations that would come

between infantry and cavalry commanders and their fire support assets. Also, one cannot discount the institutional tendency to keep everyone in their proper place--in other words, to keep a new power group from organizing. The field artillery component of the Army had traditionally been small and well submerged within the peacetime artillery regiments. The great buildup of the maneuver army after Bull Run swelled the ranks of the field artillery and gave it a de facto status which approached that of a separate branch. It was the failure of the establishment of the Army to formally recognize the new numerical importance of the field artillery, by adjustments in commissioned rank, that led to much frustration on the part of field artillery officers.

Although institutional resistance to change was no doubt an important factor in the failure of the field artillery to achieve an organizational status commensurate with its size, it was not the sole cause. The resistance reflected to some extent the concept held by the military establishment of the combat role of the field artillery. Very simply, the concept was that light guns were best handled in small groups, which, of course, did not prevent the massing of many such groups when conditions required it. The concept of employing artillery in small groups was the logical outgrowth of both the past experience of a small army and the maneuver and firing-site restrictions of line-of-sight artillery on many American battlefields. In other words, a tradition of small unit employment in situations that often did not permit the use of more than a few direct-fire guns, if any, tended to operate against the movement to give the field artillery a formal organization above the battery. Finally, as will be seen later in this chapter, the apparent declining usefulness of field artillery could only

reinforce resistance to change in its organizational structure. The traditional American concept of employment, combined with institutional resistance to change, and later, a perceived decline in the usefulness of field guns would continue to submerge the field artillery within the structure of the Army for many years.

In early 1862, McClellan began his final preparations for the Peninsula campaign. He drew about him all the artillery that he could reasonably muster. He asked for and received half of the total artillery of the Regular Army equipped as field batteries. ⁴⁹ Men could be withdrawn from coast defense stations because of the relatively low maritime threat posed by the Confederacy. When he embarked for the Peninsula, twenty of his forty-nine field batteries were Regulars; the rest were volunteers. Of the forty-nine batteries, eighteen were organized into the Artillery Reserve. ⁵⁰ His field artillery for the campaign contained a total of 299 pieces. In addition, his siege train consisted of 71 heavy weapons. ⁵¹ It was a formidable force, organized on the basis of Barry's plan.

The campaign went badly for McClellan. As he withdrew to the James River, he concentrated his army around Malvern Hill to await Robert E. Lee's next assault. The hill offered the artillery of the Army of the Potomac excellent fields of fire from its cleared slopes. In the late afternoon of 30 June, Colonel Henry J. Hunt, commander of the Artillery Reserve, worked feverishly to get his batteries into position. With great effort, five companies of heavy siege guns were also pulled up the hill. In addition, Federal divisions with their own artillery began to file into position. ⁵² When the sun rose the next day it lit a hill bristling with artillery.

The massed guns of Napoleon were famous for their offensive power; the massed guns of the North, however, made their reputation on the defense. At the start of the battle, Confederate batteries tried to silence the Union guns, but it was an unequal contest from the beginning. The Southern Artillery Reserve was poorly handled; access roads into the battle area were few; and rifled artillery within the Union lines battered Confederate smoothbore batteries at ranges beyond the ability of the latter to reply.⁵³ The attacking brigades had to take the full force of Union cannon fire. Sixty guns under the immediate control of Colonel Hunt shifted their fire about the field.⁵⁴ Most of the infantry was halted before it reached 150-200 yards from the muzzles of the Union guns.⁵⁵ The Confederate general D. H. Hill remarked, "It wasn't war--it was murder."⁵⁶ Over five thousand of Lee's men died that day; Hill said that more than half were slaughtered by artillery, in his opinion, ". . . --an unprecedented thing in warfare."⁵⁷ Counterbattery fire and defense against infantry, these were the demonstrated strengths of the artillery at Malvern Hill.

The commendable performance of the Union field artillery drew praise from many officers. Major General Fitzjohn Porter, the commander of Fifth Corps, endorsed Hunt's report of the action at Malvern Hill and recommended that some action be taken to secure promotion for artillery officers who had forgone volunteer appointments at higher rank in other branches in order to remain with their arm.⁵⁸ Porter's gesture did not solve the rank problem in the artillery, but it was an indication of the esteem with which the artillery was held by those who dealt directly with it at Malvern Hill.

The next Union thrust in the East was made by Major General John

Pope's Army of Virginia. Pope had no plan of organization for his artillery comparable to the one that Barry had drawn up for the Army of the Potomac. His guns were still assigned in the old style to brigades rather than divisions, and he had no artillery reserve. At the Second Battle of Bull Run, Pope's scattered guns failed to make much of an impression on the Confederates. Even in the counterbattery role, Pope's poorly managed artillery was generally ineffective.

Meanwhile in the Army of the Potomac, Barry had moved to a staff position in the War Department, and Colonel Hunt, the commander of the reserve, had been appointed Chief of Artillery. Hunt was commissioned in the Artillery in 1839. He had served with distinction in James Duncan's famous battery in the war with Mexico. The prohibition against artillery staffs was still in effect, so the new chief accomplished much of the reorganization of the army's artillery in person.

Hunt's former command, the Artillery Reserve, was reduced from eighteen batteries to seven. McClellan had eight divisions with him when he began the Peninsula campaign; by the time he reached the fields around Sharpsburg, he had eighteen. Some of the units that had arrived from Pope's army had lost portions of their artillery; cannons were withdrawn from the reserve to meet the needs of the divisions.

With respect to the organization of field artillery, the Army of Northern Virginia was not as inflexible as its Northern opponents. At the time of the Peninsula Campaigns, the Confederate Artillery Reserve under Brigadier General William N. Pendleton was indeed organized into battalions, although the artillery with the infantry divisions was still assigned by battery. The divisional artillery was committed piecemeal at Malvern Hill, and it proved itself to be relatively

ineffective. Before Lee invaded Maryland, he began a reorganization of his artillery. One battalion was assigned to each division; one reserve battalion was held at corps, and the remainder of the artillery was retained in the general army reserve. The reform was not rigidly implemented,⁶³ but it went well beyond the former scheme in the centralization of control of the batteries. Staff officers were available for the Confederate reorganization. They had been authorized by an enactment of the Confederate Congress as early as January 1862.⁶⁴

When the two armies clashed at Antietam, the fight was a confused affair: both sides resorted to desparate, piecemeal attacks. The performance of the Union artillery was uneven. Many batteries were well handled, but others failed to contribute much. As a general statement, there was a lack of close support for the infantry, the kind of support that would have permitted concentration of well directed fire to assist Union assaults.⁶⁵ On the other hand, in the defense, the overwhelming fire of Federal batteries on Confederate counterattacks may have saved McClellan's hard pressed right. In Hunt's reduced Artillery Reserve, five of the seven batteries contained 20-pounder Parrott guns. Too heavy to be considered light artillery, they were treated as guns of position and were sited on the heights east of Antietam Creek. Their principal occupation during the battle was counterbattery fire, a duty that they discharged with some success.⁶⁶ Although it was not a picture book defense like Malvern Hill, Union batteries again demonstrated their efficiency against attacking infantry and enemy artillery; but their absence in close support of the II Corps, in its near penetration of the Confederate center, may have cost the North an overwhelming victory.⁶⁷

Hunt had his problems after Antietam. There was some sentiment among senior commanders to abolish the Artillery Reserve. Some officers felt that it had failed to provide exactly the kind of offensive power that warranted its creation and maintenance. They preferred to have the cannons distributed to the divisions. Whether or not the reserve at Antietam could have lived up to their expectations is questionable. The fact is that most of the mobile field artillery had already been distributed to the divisions leaving the reserve composed principally of heavy 20-pounders. One of the arguments advanced by the detractors of the reserve was that if massed artillery were needed it could be drawn from the divisions. The new commander of the Army, Major General Ambrose Burnside, pondered the debate and seriously considered doing away with the Artillery Reserve.

The debate over the future of the reserve reflected, to some extent, a growing awareness of the limitations of field artillery in the offense. It is a truism that the initiative in the selection of the point of assault generally rests with the attacker. The employment of the reserve in the Napoleonic concept was a means to exploit that initiative. Given the firing site limitations of direct-fire artillery, logic would indicate that in many defensive situations the most efficient employment of an army's field guns would be forward on the line, ready to meet the enemy attack. Since the choice of the point of the assault rested with the attacker, logic would further indicate that the guns should be rather evenly distributed across an army's front. The relative failure of Federal field artillery in offensive support invited the conclusion that the reserve should be broken-up, and the guns distributed to the divisions.

In December 1862, at Fredericksburg, however, the hazards of a river crossing operation in the face of the enemy convinced Burnside that he still needed the protection of the massed fires that a properly handled reserve might provide. Of the sixty-seven field batteries that were with the army, nine were then held in the Artillery Reserve.⁷⁰ Burnside augmented this small force by requiring division commanders to yield another twenty-one batteries to Hunt's temporary control. The Chief of Artillery divided the expanded reserve into four "divisions" and posted them to the high ground north of the Rappahannock. The batteries placed a great weight of iron on Fredericksburg and other crossing sites, but they were largely ineffective against the scattering of skirmishers that harassed the bridge laying operation. Against the Confederates in Fredericksburg, cannons were particularly ineffective; and although the guns turned much of the town to rubble, they could not put an end to the sniping. Finally, boatloads of Union infantry had⁷¹ to be landed to drive the riflemen away from the river edge.

Union divisions, rearmed with their own artillery, soon crossed the river. But their guns did little to alleviate the embarrassment that they suffered from Lee's army the next day. An attack through wooded country against the Confederate right achieved a limited but short-lived success. The main assault then shifted to the Southern left. There, before Marye's Heights, the picture book battle of Malvern Hill was replayed with reversed roles. Federal infantry had to cross open fields to reach the Confederate line. Behind the Southern riflemen, who were protected in a sunken road, three battalions of artillery lay in silent wait. On the Federal side, the divisional batteries of the assault force were poorly handled; they were committed in piecemeal

fashion, and some never left the streets of Fredericksburg. The guns of the Union Artillery Reserve contributed their long-range support; but the Confederates, remembering the effective counterbattery fire of Antietam, had dug protection pits for their field pieces. ⁷² Six thousand Union soldiers died in the hail of rifle and cannon fire from Marye's Heights, before the repeated attacks came to a halt. Again artillery had demonstrated its utility in the defense and its considerably lower efficiency in the assault.

It would be a mistake, however, to think that the idea of offensive action--the heritage from Napoleon and the American tradition set by the batteries of Captains James Duncan and Samuel Ringold at Palo Alto in the Mexican War--died completely. From the beginning until the end of the Civil War, there were isolated instances of the aggressive forward employment of artillery. Perhaps the best known example is Major John Pelham's performance in support of Jackson on the right of the Confederate line at Fredericksburg. James E. B. Stuart had ordered his young horse artilleryman to an exposed forward position on the flank ⁷³ of a Federal division moving to assault Jackson's line. ⁷⁴ With two guns, at a distance that may have been as close as four hundred yards, Pelham brought the division to a halt. Four Union batteries put him under fire. Their bombardment soon took its toll; his rifled piece was put out of action, and several of his men became casualties. With a 12-pounder he continued to harass the stalled division while intermittently exchanging fire with the Federal guns. When counterbattery fire found his range, he would shift to a new location. On Stuart's third ⁷⁵ recommendation to withdraw, he finally abandoned the unequal contest. Pelham's performance was a dramatic demonstration of what could still be

done with sufficient courage and luck; but it was a throwback to an era of shorter engagement ranges; and it was not to be repeated often in the age of rifling.

The end of the Federal assault at Fredericksburg brought a lull of several months to the fighting in Virginia. Lee began to complete the reorganization of his artillery. He withdrew artillery battalions from divisions and concentrated them at corps. At the same time, the army reserve was reduced to six batteries. Also, he assigned a second field grade officer to each battalion. These changes increased the centralized control of his guns and improved artillery efficiency. ⁷⁶

Lee also used the lull to prepare a twenty-five mile line of fortifications south of the Rappahannock. It was the most extensive system of prepared positions yet seen on the field. The recent lesson of the destructive power of Longstreet's protected infantry and artillery was a strong one. ⁷⁷ At the same time, an ominous shortage of horses and fodder haunted Lee. He mentioned it as one of the chief reasons that he could not take the offensive in the months that followed Fredericksburg. More important than the hunger of his animals was the growing malnutrition of his soldiers. The country around the army yielded little, but there was food in the lower South; the problem was one of transportation. ⁷⁸ The lethality of the rifle, the appearance of the trench, the shortage of horses, and the difficulty of supply were ominous early signs of a drift toward position warfare.

The Army of Northern Virginia had one good offensive victory left in it. In early May of 1863, the team of Lee and Jackson crushed Major General Joseph Hooker's thrust into the woods of central Virginia. The country around Chancellorsville was close, with the exception of a

a few scattered clearings, and the maneuver of artillery was difficult. As the Federals struggled desperately to keep their line of retreat open, both sides threw the artillery that could be gathered into the small cleared areas around Fairview and the crossroads at Chancellorsville. The Confederates pushed twenty-five cannons into the field at Fairview. Union artillery responded, but the gunners missed the guiding hand of Hunt who had been sent by Hooker on a relatively insignificant mission to another part of the battlefield. It was a shabby artillery battle, fought at close quarters. The battle demonstrated the difficulty of using direct-fire artillery in wooded terrain.

The technological limitations of direct fire were a fact with which one had to live. In contrast, however, systems of control could be changed. Hooker overreacted to the piecemeal performance of his artillery at Chancellorsville. Afterward, he wanted to leave one battery with each division, concentrating the rest in a huge reserve. Hunt's view was more balanced; he convinced his chief that what was needed was the organization of artillery brigades at corps. At the same time he campaigned for a staff for each brigade. The divisions lost their artillery to the new brigades which varied in strength from four to eight batteries depending on the size of the corps. Of course, Hunt retained his reserve which continued to consist of about one-third of the artillery of the army. The new brigades were improvised formations: the battery remained the highest legal organization for the field artillery.

The problem of rank in the field artillery continued to frustrate Hunt. After Chancellorsville, he complained:

In this campaign, for command of 67 batteries (372 guns), with over 8,000 men and 7,000 horses, and all the material, and large

ammunition trains, I had 1 general officer commanding the reserve and but 4 field officers In the seven corps the artillery of two were commanded by colonels, of one by a major, of three by captains, and one by a lieutenant, The most of these commands in any other army would have been considered proper ones for a general officer.⁸³

Hunt's pleas brought no substantial change to the rank structure, and good artillerymen continued to quit their branch to take volunteer commissions with the infantry.⁸⁴ The commanders of the new brigades tended to remain officers of junior rank; and the staffs that Hunt sought appeared only in skeleton form. By calling his organizations "brigades" Hunt was no doubt continuing his campaign for higher rank for his artillerymen.⁸⁵ His repeated calls for promotions, although they may have been justified, no doubt contributed in some degree to the resistance that the artillery met within the military establishment.

With respect to the Artillery Reserve, Hunt blunted Hooker's overreactive impulse to increase it; but he was not willing to see it diminished. In contrast, Lee broke-up what remained of his reserve in May of 1863.⁸⁶ Confederate action anticipated later European artillery organization. The Prussians abandoned the concept of a reserve before their war with France; and other nations made similar changes.⁸⁷ It was a growing recognition that a reserve was no longer necessary, particularly if there was a danger that guns would remain idle in the rear.⁸⁸

The last great battle of maneuver in the Eastern theater was fought at Gettysburg. The rolling, open terrain invited the use of artillery by both sides. It was a momentous cannon duel that opened Lee's final assault on the 3d of July, 1863. The corps artillery of both Longstreet and A. P. Hill had been lined up almost hub to hub to bombard the Federal guns on Cemetery Ridge. The disposition of the Confederate artillery suffered from one serious misjudgement. Its fire

was generally perpendicular to the line of Union guns, which meant that it had to have pinpoint accuracy in range. Many of the shells fell long and were wasted. Union batteries replied until ammunition stocks dwindled. Hunt could not find the Union commander, Major General George Meade, so he took it upon himself to give the order to cease fire and pull back from exposed positions. The Confederates mistakingly assumed that their counterbattery fire had done its work, and Major General George Pickett launched his attack. Nearly fifteen thousand men lined up for the mile long march to the Union lines. Federal artillery, previously withdrawn, was hurried back into position. The attacking lines were hit at long range by shot and shell and then smashed again and again at close range by canister. At 300 yards the Union infantry, crouched behind whatever protection was available, fired its first volleys. Under the combined weight of small arms and cannon fire the attack was decimated. Some of the Confederate artillery had limbered up and moved forward behind the infantry, but ammunition was too low and the guns were too few to affect the battle.

The end of operations in 1863 marked a turning point in the style of war in the East. Soldiers had long sought any available cover from the deadly fire of rifles. At Fredericksburg and again at Chancellorsville, Lee's army had used planned field fortifications, which was a step beyond the efforts of individual soldiers at self-protection. However, it was not until after the Battle of Mine Run, in late November 1863, that the declining strength of the Army of Northern Virginia forced it increasingly on the defensive, and field fortifications became a routine.

The inability of either side to achieve a tactical decision

rested on several factors. The mobilization of large democratic populations, the vast theaters, and the state of technology all combined to draw out the struggle. Of these three, the state of technology, and particularly weapons technology, probably did the most to lengthen the war. The rifle with its fearful lethality against exposed infantry blunted the decisiveness of the attack. It drove the infantry to cover, which strengthened the defense. Against covered infantry, direct-fire field artillery had little effect. Effectively deprived of its fire support, the attack suffered further degradation. An exhausted South was forced to give up the attack as a means to successfully terminate the war. The initiative lay with the North, and by a steady attritious grind she eventually brought the conflict to an end.

At the beginning of 1864, however, the road ahead was still a long one. Lieutenant General Ulysses S. Grant assumed responsibility for the direction of the Union armies in March. His plan was simple--to continue pressure upon the South regardless of the consequences. He chose to locate himself with Meade's Army of the Potomac. That army had recently been reorganized into three large corps, the II, V, and VI, and it would soon be joined by the IX. The artillery had been reorganized at the same time. Corps brigades were increased to eight or nine batteries. The reserve consisted of two field artillery brigades of twelve batteries each, one heavy artillery brigade, which was largely employed as a guard and construction unit, and two brigades of horse artillery, which were on duty with Major General Phil Sheridan's
91
cavalry corps. Hunt still had not received authorization for the staff organization that he sought for the artillery, and as he had done
92
several times in the past, he repeated the request--again in vain. Its

reorganization complete, the Army of the Potomac moved into the Wilderness. Just as at Chancellorsville, the field artillery was hard pressed to find useful employment in the wooded thickets.

On 9 May, eight 24-pound brass Coehorn mortars were assigned for the first time to a battery of Hunt's artillery. The short mortars were fixed at an angle of 45 degrees which permitted them to hurl a shell in a high arch to a distance of 1,200 yards at full charge. They weighed just 164 pounds, light enough to be carried by 2 men. The mortars provided the artillery with the capability of delivering fire that was not restricted by the close vegetation, although observation of the target was still a problem. And more important, an occasional well placed round could be delivered into an enemy trench--it was a feat that the guns and howitzers of the field artillery could not duplicate. Union gunners used the mortars with some success at Cold Harbor. They prompted the Confederates to attempt high-angle fire of their own by raising the barrel of one of their field pieces. The Union mortars returned fire and the Confederate gun went silent. Sufficiently impressed with mortars, the Confederate artilleryman Colonel E. P. Alexander submitted a request to the Ordnance Bureau in Richmond for a supply.

While the Coehorns were proving their value, the regular batteries were clogging the roads and finding only occasional employment. Finally, Grant ordered that the Artillery Reserve be returned to Washington. Hunt, ever careful to protect his artillery organization, recommended to Grant that batteries throughout the army be reduced from six to four guns and that the excess weapons be sent to Washington. Grant accepted the recommendation, however Hunt lost his

Artillery Reserve as the reduced batteries were distributed to the
 96
 corps. Grant had the following to say about his decision to reduce
 the artillery:

The Wilderness and Spottsylvania battles convinced me that we had more artillery than could ever be brought into action at any one time Artillery is very useful when it can be brought into action, but it is a very burdensome luxury where it cannot be used. . . . , therefore, I sent back to the defences of Washington over one hundred pieces . . . this still left us more artillery than could be advantageously used. . . . , before reaching the James River I again reduced the artillery⁹⁷

Hunt was sensitive about previous criticism of the reserve. After the order to disband it, he offered the following defense of the defunct organization in one of his periodic reports to army headquarters:

. . . it had done its full share of fighting . . . , while it has rendered other and fully as important services. . . . , its ammunition trains supplied the batteries of the divisions, Whenever, , the ordinary amount of artillery attached to troops proved insufficient, it has supplied the deficiency. Its batteries in all our great battles have always gone into action at critical moments, Batteries in the corps losing their efficiency . . . , have been at once replaced from the Reserve,⁹⁸

This vestage of the Napoleonic heritage died hard. However, from Hunt's summary of the service of the reserve, it is clear that its function had become one of resupply and reinforcement. Others had questioned the utility of the organization: Grant put an end to the debate.

As Grant drove south into the Wilderness, both sides entrenched routinely. After the disastrous attack at Cold Harbor, Union troops threw up fortifications that in some places were within fifty yards of the Confederate line. Bloodied tremendously in their stand-up attacks, they even began to cut zig-zag approach trenches to avoid further punishment from Confederate rifles. Artillery was present on both sides at Cold Harbor, but as Lee remarked to a visiting cabinet member

distracted by small arms fire, "It is that that kills men."

When McClellan first threatened Richmond from the Peninsula in 1862, Confederate engineers began the construction of fortifications to protect both the capital and the Petersburg rail center to the south. Two years later, Grant, continuing his leftward shift, again placed the Army of the Potomac on the Peninsula. At the same time, the XVIII Corps from Major General Benjamin Butler's habitually inactive Army of the James moved west to threaten Petersburg. The Army of Northern Virginia responded by occupying the Richmond-Petersburg defenses, and the long siege began.

In April, before the Union Army began its move south, Meade had foreseen the coming siege, and he arranged for a train of heavy artillery to be assembled at Washington. In May, the train was shifted to Butler's army, and when the siege of Petersburg began the next month, the guns of the First Regiment of Connecticut Heavy Artillery were ready. Initially the train consisted of forty rifled siege guns (4.5-inch and 30-pounder Parrotts), ten 10-inch mortars, twenty 8-inch mortars, twenty Coehorn mortars, and a reserve of six 100-pounder Parrotts. This initial force was supplemented as the battle for Petersburg continued. ¹⁰¹

The Confederates strengthened their defenses into formidable systems. The line was indented to afford positions the mutual defense of flanking fires; artillery was placed in strong redouts; and abatis and other obstructions covered the front of the earthworks. ¹⁰² On 9 July, the command officially informed the Army of the Potomac that operations against Petersburg would be regular approaches--siege warfare. ¹⁰³ A regiment of Pennsylvania miners began to tunnel under the Southern defenses. To support the attack that was to follow the explosion of

the mine, Hunt began to assemble his siege artillery. Counterbattery fire was the artillery's first priority; but direct-fire weapons could do little damage to the Confederate guns posted as they were behind ramparts of logs and earth. Mortars from the siege train were brought forward to lend their vertical fire to the attempt to suppress the Confederate batteries. ¹⁰⁴ A total of 110 guns and 54 mortars supported the Federal attack. But the assault failed, principally because of confusion and poor leadership in the attacking columns. However, although it fired more than thirteen thousand rounds, the artillery could not silence the entrenched Confederate guns or prevent a counter-attack. It was yet another example of the growing ineffectiveness of Civil War artillery in support of the offensive. ¹⁰⁵ The mine assault was Grant's last major frontal attack until the closing days of the war.

At the beginning of the Civil War, the field artillery of the United States Army was a handful of batteries buried deeply within artillery regiments, numerically dominated by heavy guns. In spite of its small proportional representation, the field artillery enjoyed the fame won by its gunners over a decade before in the war with Mexico. And beyond the immediate glory, there shone the Napoleonic example of what field artillery could do when pitted en masse against a waiting enemy. The American Civil War brought the mass demanded by the Napoleonic model, but the adoption of the rifle by the infantry changed the equation. No longer could artillery be thrust forward in the attack. And the infantry attack itself was degraded as defending rifles devastated advancing soldiers. To save themselves, men sought what protection they could find. This further reduced the effect of artillery,

which was unable to engage hidden targets with much efficiency. If the enemy dared to assault, field guns could still cut down men deprived of cover. But in support of the offense, artillery had lost much of its sting. It fared better when pitted against its own kind in the counterbattery role. The effect of the new battlefield equation was to blunt the decisiveness of war. There were other factors of course, large manpower resources and vast theaters, to name two; but near the heart of the matter rested the relationship between the rifle, the trench, and the field artillery.

The fame of the American field artillery did not improve as a result of the new relationship. General Hunt's attempts to give the arm a more powerful organization met with continual resistance. Part of the difficulty was, no doubt, institutional rigidity. But then one must ask if the contribution of field artillery in battle clearly warranted increased recognition. Of course, there was also rigidity on the other side, Hunt's insistence on the maintenance of an artillery reserve was a throwback to the Napoleonic model. In essence, what emerges is a clash of old concepts and new realities with no clear solution.

CHAPTER II

ANALYSIS OF THE PROBLEM

The essential problem for those who must fight wars is to kill without being killed. It is not only a matter of personal survival--it is a matter of success--for the one who remains standing in the end is the victor. This truism is at the heart of the actions of the private who must fight, the general who must direct, and the planner who must prepare. Of course, the private understandably fixes his orientation upon survival. The general and the planner likewise are concerned about preserving the private; for if he is gone their side will not stand in the end.

Artillery is important in war because it is a means to kill without being killed. Firepower is a substitution for manpower. Of course, the rifle is also a firepower device, but it is a tool of the individual soldier. He uses it when he closes with the enemy. Artillery and other support weapons are of a different nature. When effectively used, the damage done by support weapons reduces the risk to the soldier who must ultimately put an end to the enemy's resistance. Of course, if the other side is equally effective in its use of support weapons, the advantage tends to be cancelled. However, the hope is ever present that through quality, quantity, or brilliance of application the effectiveness of our support weapons will surpass that of the enemy.

The role of support weapons in the American Army was essentially

the same in 1865 as it is today. War has changed somewhat since then. There are many support systems today; direct-fire artillery was the only major system available then. And reliance on fire support is greater now; reliance on the infantryman was greater then. But, in essence, the artillery of a hundred years ago performed the same function that multiple systems of fire support do today--to husband life by taking that of the enemy by fire.

What then was the reaction when the rifle significantly reduced the effectiveness of field artillery? One might expect a rush to restore the potency of fire support. But the rush failed to occur.

The failure was a curious one. Soldiers recognized that the effect of direct-fire artillery was degraded by the trench. Proof of the recognition was the resort to the ancient mortar. But as the historian Douglas Southall Freeman remarked about the campaign at Petersburg, "It was seldom that the artillerists of either army got the exact range of the trenches, but they fired steadily, sometimes furiously, . . ." ¹ An occasional mortar round might hit a trench, but it was no restoration of the offensive authority of the artillery. The difficulty posed by the trench was recognized; however there was no immediate and positive search for its solution.

As of 1865, the trench was a problem for which there was no apparent solution. The Army of the Potomac accepted the limitations imposed by the trench and "muddled through." At Petersburg, Grant finally gave up his efforts at mass fire and frontal assaults and resorted instead to slow attrition. It was simply a manifestation of man's capacity to adjust to his environment when he intuitively senses that he is powerless to change it.

In forty years, a major change in artillery fire support would provide an answer to the trench. However, the role of artillery in the eventual answer was not foreseen in 1865. Two factors operated: first, there was no apparent solution for the trench; second, the artillery was not condemned for its failure to resolve the difficulty. The two factors were interrelated. The first step in recognizing the potential of the artillery was the realization that with some modification it could do the job better; in other words, a condemnation of inadequacy. But the artillery was not condemned for its failure to solve the problem of the trench. Quite simply, the artillery was not condemned for failing to accomplish something that was never conceived to be within its capability in the first place. Rather than become an object of criticism for its failure to handle the trench, the artillery simply tended to fade from attention. It was this lack of publicity that prompted a French student of artillery at the end of the war to complain that, "The Americans have made campaigns, delivered battles both numerous and bloody, and yet none of their bulletins mention that the artillery has played an important role, . . . " ² Technological advance would eventually demonstrate that artillery could provide a solution; but the state of the art was not that far advanced at the end of the Civil War.

The end of the war itself was a factor in the failure of the American Army to actively seek a solution to the trench. As the war drew to a close and the trench began to cause the greatest difficulty, the North was obviously winning. This reduced the threat incentive to find a solution. And when the war ended, the problem itself ended--except in theory. But the most important factor was the state of technology. There simply was no apparent solution. The eventual

solution lay in an evolution from a concept of direct fire to one of indirect fire.

There are several differences between the two concepts. With respect to trajectories, the dividing line is imprecise. It is not enough to say that direct fire is flat and that indirect fire is curved. Gravity demands some elevation on all fire, and the requirement for elevation increases with range. The absence of a precise, universal delineation between direct and indirect fire may disturb perfectionists and confuse the rest, so, for the purpose of this study, let 20 degrees elevation stand as the general maximum to be called direct fire.

Trajectory is only the most apparent difference between the two concepts: there are others. The short range and line-of-sight characteristics of direct-fire engagement have been discussed elsewhere. It is sufficient to restate that both limited the number of potential firing sites for direct-fire artillery. In contrast, the eventual concept of indirect fire featured higher trajectories, longer ranges and engagement that was not limited to line-of-sight restrictions. The result was a multiplication in the number of potential firing locations from which artillery could attack a single target, figure 2. Of course communications were necessary to tie the new system together; time would provide the telephone. One advantage of the new system was the ability to shift the fire of a great number of pieces about the battlefield without having to move the guns. This permitted the use of heavier artillery with field batteries. Previously, within the direct-fire concept, cannons had to be light enough to maneuver with the close combat forces, the infantry and the cavalry. When this restriction was reduced by the advent of indirect fire, greater shell size was possible.

FIGURE 2
DIRECT AND INDIRECT FIRING SITES

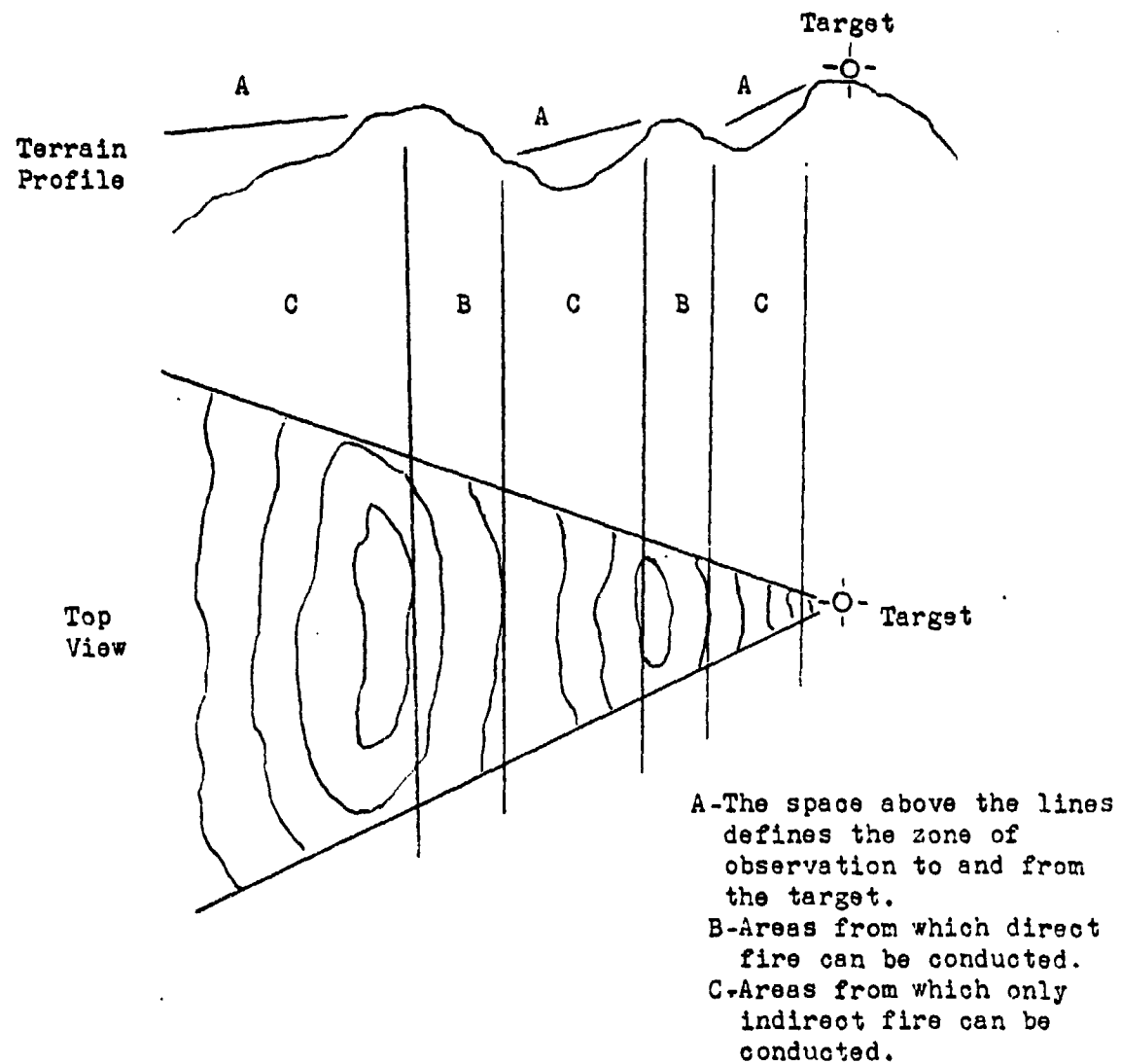

Larger ammunition fired from a greater number of sites increased the weight of explosive that could be placed upon a target. Technology added to that weight by increasing the rate of fire of single weapons. Napoleon's best gunners claimed a rate of 5 rounds per minute,³ but by 1900, 20 was common. However, a large volume of high-trajectory, heavy fire was an incomplete answer to the trench.

At the heart of the problem lay accuracy. But before considering accuracy, it is necessary to understand the bursting effect of an artillery shell. The common artillery shell explodes upon contact with the ground creating a casualty producing zone. The shape of the zone is modified by the design of the shell, the angle of impact, and the depth of penetration before detonation. The limit of the zone is further obscured by the various ranges at which individual shell fragments will produce injury and the divergent paths that they take from the center of blast. The result is that some targets quite near to the center of blast may escape injury while targets at greater distances become casualties. However, to simplify this discussion, let the zone be an idealized hemisphere, and let the hemisphere transcribe the area in which 50 percent of the man-sized targets can be expected to become casualties. Since the hemisphere will vary in radius with the size of a shell, let 25 yards represent the casualty producing radius of a hypothetical shell. The impact of the shell among troops standing in the open can be expected to turn 50 percent of those within 25 yards of the blast into casualties. However, if the same troops are in a trench, they are protected from shell fragments, unless, of course, the shell lands in the trench. The protection that trenches afford troops reduces the efficiency of artillery.

The problem that the trench posed to direct-fire artillery was quite simple: the angle of impact of the round was too low to permit a shell to enter the trench. A parapet formed of the earth thrown from the trench was sufficient to close off the narrow exposure of the opening to direct fire, figure 3.

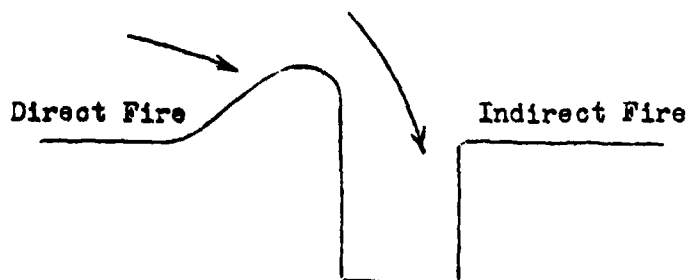

FIGURE 3

ARTILLERY FIRE AND THE TRENCH

Indirect fire, was an answer to the trench. But indirect fire was not an easy solution. The essence of the problem was accuracy. The following discussion draws upon firing data for the Whitworth 3-pounder, a weapon that was regarded as quite accurate at the time of the American Civil War.

In one series of tests, a total of 28 rounds were fired at an angle of 20 degrees. The average range was 6687 yards. The rounds impacted with average longitudinal and lateral deviations of 64 and 5.2 yards respectively. ⁴ The wide difference between the two resulted from the tendency of artillery to be much more accurate in deflection than in range. This data has been used to construct the hypothetical impact zones shown in figure 4.

Sketch A is an area defined by the average longitudinal and lateral deviations of rounds aimed to impact at point O. It approximates an impact zone into which each projectile stands a 50 percent

chance of landing. The longer axis is parallel to the direction of flight of the artillery shell. Errors in range occur along this axis. Errors in deflection occur on the shorter perpendicular axis. One half of the rounds would land above point O, and the rest would impact below it. Also, one half would land to the left of the center, while the remainder would hit to the right. Of course, the density of impacts would increase toward point O, but for the sake of simplifying this model, assume an even distribution throughout the zone.

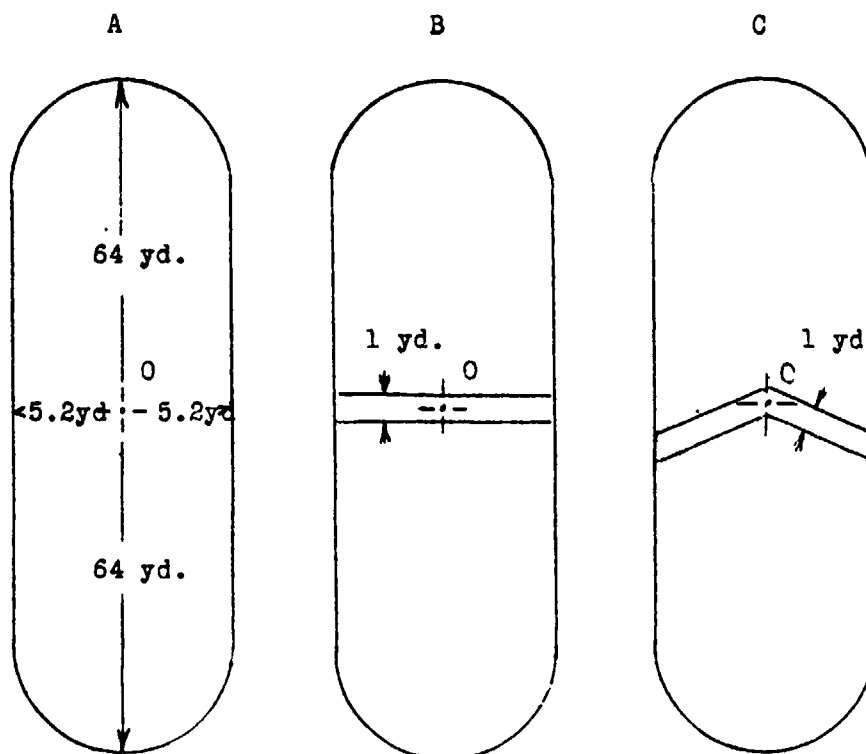

FIGURE 4

PROJECTILE IMPACT

Sketch B is the same impact zone with a straight yard wide trench as a target. Again, to simplify the model, assume that the zone approximates a rectangle. The area enclosed by the zone is about 1330 square yards. The area of the trench is 10.4 square yards. The ratio of the

two is 128 to 1. Assuming an even distribution of impacts, something on the order of 2×128 or 256 rounds would have to be fired to insure that one would fall in the trench. (Each round has only a 50 percent chance of landing in the zone.) Of course, a round of large size would not have to enter the trench; a near miss might do. Because of the straight line construction of the trench, one round could do great damage to the defenders. To prevent such damage, trenches are constructed in a broken line as shown in sketch C. The effect of the blast is thereby restricted to a smaller segment of the trench. In a trench with 2 such segments, it might take 2×256 or 512 rounds to neutralize the entire trench. But, the entire trench in this case is only a 10 1/2 yard segment. Imagine the ammunition needed to neutralize 1000 yards of enemy front with two or three consecutive lines of trenches. Of course, a complete neutralization is impractical, but on the basis of the preceding discussion one can understand why the answer of the artillery to the trench was a tremendous volume of accurate, curved fire.

There may be some confusion in the use of the term "indirect fire"; purists might insist that the method of aiming, either by direct sighting or indirect lay, determines whether fire is direct or indirect. But as can be seen from preceding paragraphs, the concepts have a broader meaning in this study. However, the method of aiming is not unimportant.

Accuracy is the product of many things, but it is critically dependent upon the method of aiming. Aiming at the time of the Civil War was called "pointing" which is rather more descriptive of the imprecise procedures of the day. Of course, when evaluating the methods of

pointing, one should keep in mind that the artillery itself was relatively inaccurate; therefore, there was no need for a finely tuned system of directing fire. In other words, if the basic accuracy of the artillery piece, irrespective of the method of aiming, was no more than ten yards laterally at a given range, then a system of aiming that was accurate to seven yards would be accuracy lost. Two methods of pointing were used: one for guns and howitzers within line of sight of the enemy, and one for mortars behind ramparts.

To point guns and howitzers, a line was drawn parallel to the cannon barrel, intersecting the high point on the base ring and the high point on the swell at the muzzle; this was the "natural line of sight," also known as the "line of metal." Since uneven ground could cause one wheel to be higher than the other, the natural line of sight tended to rotate a few degrees over the top of the barrel. To find the highest points on the barrel the gunner would use a level. When going into action, gunners would mark the points of intersection of the line of sight on the base ring and muzzle swell with chalk. Only when firing at point-blank range did gunners sight directly along the chalk marks. When firing at very close targets, gunners had to depress the muzzle. But for the great majority of targets, some elevation was required. The points of intersection then defined a vertical plane which included the target. The next step required the use of a quadrant. The quadrant looked much like a carpenter's angle with a plumb bob attached. To use the device, the range to the target had to be known. With the range, the gunner could calculate the proper elevation for the barrel. Laying the quadrant in the barrel, the gunner would read the elevation, as an assistant made adjustments with the elevating

mechanism at the rear of the gun. Once the elevation was set, the gun was aimed. Instead of a quadrant the gunner might use a breech sight. The sight would be set for the range of the target, and then it would be attached to the highest point of metal on the base ring. The gunner could look through the notch on the sight and across the chalk mark on the muzzle, and by manipulating the elevating mechanism, bring the two points in line with the target. The gun was then aimed. In the absence of a breech sight or a quadrant, the gunner would lay one or more fingers upon the base ring, perpendicular to the axis, and use them as a
5
breech sight.

Since mortars were often located behind ramparts, out of sight of the enemy, gunners had to use artificial aiming points. There were several methods, but all involved the same principles. In one method, the gunner would select two points on the rampart in line with the target and visible from the gun. He would mark the points with stakes. After tying a pointing cord on the farthest stake he would stretch it past the near stake to a point one yard behind the mortar, where he would plant a third stake. Using a plumb bob suspended from the pointing cord he would bring the chalk marked line of metal on the mortar into the vertical plane defined by the plumb bob and the front stake. The farthest stake would be removed, and the pointing cord would be tied to the near front stake. At the base of the rear stake, the gunner would place the plotting board, which was a piece of wood 1 foot long, 2 or 3 inches wide, and 1 inch thick. The board was notched at regular intervals. After firing, the mortar could be adjusted left or right by stretching the pointing cord to the appropriate notch and realigning the
6
line of metal with the new vertical plane.

These were primitive methods of aiming. They did not permit the degree of accuracy that was needed to engage trenches without prohibitive costs in ammunition. Technology, however, would eventually provide better systems.

When the rifle and the trench first demonstrated their predominance in battlefield tactics, the artillery was incapable of immediately answering the challenge for a variety of reasons, not the least of which was the technical inability to deliver heavy shells in massed, reasonably accurate, high-trajectory fire. One should not conclude from the abstract discussion of the last few pages that the evolution to a system of indirect fire was simply a matter of overcoming successive technological problems.

The problems associated with the development of high volume, accurate, curved fire were substantial. At the end of the Civil War none of the components necessary for an effective indirect-fire system were available. There was little that could be transferred from the direct-fire system without substantial development. Gun and carriage design, propellants, explosives, methods of aiming, and fire control, all required significant technological improvement. Much of the industrial capacity needed to support the development and maintenance of an indirect-fire system did not exist. The tactical organization of the field artillery was primitive even for a direct-fire system; it would require a major change. If the clear goal of the Army from the beginning had been the development of an efficient indirect-fire system, it would have been a long and difficult process. But no such goal existed. It must be remembered that the analysis of the last few pages is the product of hindsight; and that the problem and solution that it outlines benefit

from that advantage; things were not so clear at the time the problem developed.

The concept of the direct-fire employment of field artillery was a powerful and persistent doctrine within the Army. The concept determined the direction that ordnance designers would pursue in the development of new field artillery materiel. Emphasis was on increasing the efficiency of low-trajectory fire. Constraints on the internal organization and size of the field artillery were largely a product of its engagement characteristics. It was organized to suit the demands of direct fire; and its numerical representation within the field army was a reflection of its expected contribution on the battlefield.

Given the persistence of direct-fire doctrine, what then was the path to the eventual solution of the problem posed by the rifle and the trench? It was one of uneven incremental technological development that continued to pursue the maintenance of a direct-fire capability. At the same time, and as a general statement, without deliberate attempt, along the path, there developed the essential ingredients of an indirect-fire system. By 1904, the ingredients were ready, and when the Japanese were the first to put together a primitive system of indirect fire in their war with Russia, the American Army was quick to grasp the potential of the new concept. The new idea loosened the grip of the old one that had persisted for so long.

The path of development from one field artillery doctrine to another was anything but simple. In the preparation of this paper, research soon revealed the complexity of interactions that contributed to the evolution. It was apparent that the doctrine was the product of a pluralism of forces, among which the state of technological advance

tended to be the most important. It was also apparent that movement into the new doctrine was possible only when the necessary body of additional technology was available. The path between the two doctrines was clearly one of incremental development. In addition, it showed many of the characteristics of unilinear advance. However, the concept of unilinear advance did not fit all of the research data. Kuhn's paradigm has provided a closer fit.

In 1962, Thomas S. Kuhn, Professor of the History of Science at the University of California at Berkeley, published the Structure of Scientific Revolutions. In his book, Professor Kuhn sought to provide a framework for understanding the history of the development of science. He was dissatisfied with older interpretations which featured the concept of scientific advance through a progressive accumulation of ideas. In the place of linear development, he substituted the concept of the paradigm. The concept of the paradigm differs from the concept of linear development in that it provides an understanding of the causes of the long periods of relative stagnation of scientific progress-- periods which were suddenly broken by significant achievement.

The paradigm was not clearly defined by Kuhn, even after his second edition in 1970.⁷ The problem is one of a multiplicity of contextual uses. However, for the purpose of this paper, the following definition will serve as a starting point for discussion: a

" . . . universally recognized scientific achievement that for a time provides model problems and solutions to a community of practitioners."⁸

Without going into detail of prohibitive length it is not possible to present a faithful reproduction of Kuhn's argument, with all of its nuances. What follows is a brief description of the operation of

the paradigm.

Kuhn began with a discussion of the prehistory of a scientific discipline. The prehistory is a formulative period in which various interpretations of observed phenomena compete with one another. Eventually, one interpretation becomes accepted by a majority of practitioners; this interpretation becomes a paradigm, and the new discipline is born (the paradigm can be understood as a theory).⁹ The paradigm both defines problems and provides for their solution; this stable situation is what Kuhn calls "normal science." Eventually the research under normal science will develop an unanticipated result, an anomaly. First the anomaly must be recognized; then, by operating within the paradigm, scientists attempt to resolve the anomaly by the process of discovery. The paradigm itself may be altered in the process, but not fundamentally. If the paradigm cannot solve the problem then a crisis is the result. Although scientists may begin to lose faith and begin to consider alternatives, ". . . they do not renounce the paradigm that has led them into crisis. . . . once it has achieved the status of paradigm, a scientific theory is declared invalid only if an alternative candidate is available to take its place."¹⁰ Forced by the crisis to seek solutions outside of the paradigm, scientist eventually will create a new paradigm. "The transition from a paradigm in crisis to a new one . . . is far from a cumulative process, . . ."¹¹ It is not achieved by an extension of the old paradigm. "Rather it is a reconstruction of the field from new fundamentals, . . ."¹² In contrast to the linear development envisioned in the concept of science as a progressive accumulation of ideas, one can see that development as defined by Kuhn is movement along a succession of plateaus.

A question arises as to what degree Kuhn's vision of the movement of the history of science can be applied to another subject. Kuhn himself makes no specific claims, but he seems to be delighted that historians and social scientists make the attempt. In fact, he is bemused by the novelty that some historians have seen in his approach, because "periodization in terms of revolutionary breaks in style, taste¹³ and institutional structure have been among their standard tools."

Although the broadest outline of Kuhn's approach may not be novel, some of the details are. The details are predicated on his interpretation of the history of scientific development, and he makes no claims of application beyond that subject. However, several of his observations explain phenomena in the evolution of field artillery doctrine that are left unanswered by an evaluation that features only a linear development of accumulative ideas.

Military doctrine is, in some ways, analogous to scientific theory: both represent a set of beliefs shared by a specific community, and both provide model problems and solutions to their practitioners. However, there are some important differences. Kuhn dealt with ideas that were subject to willful tests and objective confirmation. Military doctrine can only be tested in the haphazard occurrence of war, and the results are not necessarily definitive. For instance, artillery was hardly used in the Indian Wars. Furthermore, as a general statement, scientific theory is the intellectual distillation of human curiosity, unencumbered by any demands other than a search for "truth"; in contrast, the development of military doctrine is encumbered by the political and financial restrictions of the government that it serves.¹⁴ It is clear that military doctrine is only roughly analogous to scientific theory.

The differences invite caution. When applying Kuhn's ideas to non-scientific thought, one must be careful not to let the borrowed precepts drive the facts. His observations can be a tool of analysis, but they must not become a mold. With that in mind, one can extract from Kuhn those concepts that explain the evidence and then place the rest of his paradigm aside.

Several of Kuhn's observations provide valuable insights into the evolution of field artillery doctrine; however, none can be accepted without qualifications. When the concept of direct fire failed to provide an answer to the trench, in Kuhn's phraseology, an anomaly occurred. In the progression of his concept, Kuhn envisioned a recognition of the anomaly followed by attempts to resolve it within the paradigm. This progression fails to describe accurately what happened in field artillery development. The problem of the trench was not really viewed as one that could be solved within the direct-fire paradigm. Therefore, subsequent development tended to ignore the problem of the trench. There was a minor attempt to neutralize the trench by the use of the shrapnel round, but the effort was not very successful, and it was secondary to the intended use of shrapnel against infantry and cavalry in the open. To some extent, the divergence from Kuhn's model can be traced to the haphazard appearance of the test of war. Neither the timing nor the conditions of the tests could be controlled as they are in the empirical scientific situation. The absence of the trench in the Indian Wars made it easy to lay the problem aside. In short, the ordered progression from problem appearance through recognition to attempts at solution as envisioned by Kuhn is too well-ordered a process to describe the reactions to the anomaly of the trench. However, the basic idea of the

appearance of an unsolvable anomaly within an operating paradigm is a useful description of the relationship between the trench and the concept of direct fire.

The real value of Kuhn's model lies in his observations on the persistence of the old paradigm and its orientation with respect to the new one at the point of change. As his theory suggests, the community of artillery practitioners continued to hold to the concept of direct fire. They advanced within that concept and continued to improve their technology. Also as his theory suggests, when the new paradigm was available, the conversion was rapid. This is a plateau orientation of paradigms, and it is clearly different from the linear model.

In describing the transition from one paradigm to another, Kuhn made one major observation that is clearly not applicable to the evolution of field artillery doctrine. He states that the second paradigm is a reconstruction from new fundamentals. Even with respect to the history of scientific progress, this statement is extreme. In the case of the evolution of field artillery doctrine, it simply is not reflective of the facts. There was a cumulative progression of development within the direct-fire paradigm, and much of it was transferred to the new one of indirect fire.

To summarize, the evolution of field artillery doctrine depended on cumulative development, but it did not make a linear transition from one paradigm to another. The concept of direct fire persisted for too long, and the recognition of the supremacy of indirect fire was too sudden. Kuhn's paradigm fills the gap by providing the example of a plateau transition.

The plateau transition is one important insight into the

evolution of field artillery doctrine, but there are others. One involves an identification of the ways in which the doctrine manifests itself; another concerns a recognition of the factors that influence changes within those manifestations; and a third features the intricate weave of interactions among the influencing factors. In addition, there are two overriding lessons: the first is the complexity of the process of evolution, the second is the critical influence of the state of technology. Each of these insights and lessons requires further elaboration.

One cannot base an analysis of doctrine solely upon what is taught. To some, military doctrine signifies instructions, such as those found in field manuals; but written doctrine is not always an accurate reflection of doctrine in practice. Expediency and tradition often compete with the written word as loci of doctrine. The written word tends to reflect past experience which may or may not be applicable to current circumstances. Extended expediency is capable of producing adjustments in doctrine that transcend the written word. And tradition is the keeper of that portion of doctrine that is so obvious to practitioners that it escapes confinement in print. The written word can be taught, but the contributions to doctrine that come from expediency and tradition often fail to find their way into formal instructions.

It would facilitate an analysis of doctrine if it could be captured on the basis of what is perceived. Of course, perceptions vary from individual to individual. The variance is not necessarily great; within a community of practitioners, the variances may amount to no more than nuances. For current issues of doctrine, one could collect perceptions and then reconcile the differences to establish a base.

However, that option is not open in a historical evaluation. Time removes individuals and clouds perceptions.

A second approach to doctrine is to analyze it on the basis of what is done. There is a strong temptation to look upon doctrine as simply an idea. An idea it is, but it remains an abstraction until it is converted into action. It is doctrine in practice that is truly meaningful. When it has been recorded, what was done is an excellent reflector of past doctrine. It captures at one time the influences of the written word, expediency, and tradition. The difficulty with this approach is that what was done was not always recorded, and if so, it was not always recorded well. This tends to force the historian into occasional reliance on the written word as an indicator of past doctrine. However, where the evidence exists, what was done is the better measure.

The concept of direct fire employment manifested itself objectively in several ways, figure 5. It appeared in the selection of the materiel, specific tactics, and organization of the field artillery. Also it manifested itself in the ratio of guns to troops. These ¹⁵ objective manifestations reflected what was done.

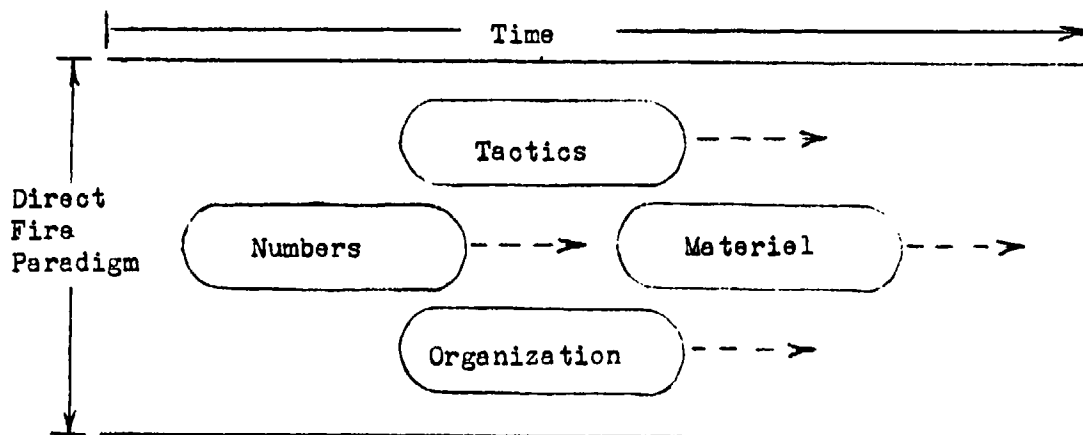

FIGURE 5

MANIFESTATIONS OF THE CONCEPT

They were not, however, simply passive reflectors of the concept of employment: they were subject to change. And it was due to such change that the doctrine remained dynamic although it was confined for a long time to the direct-fire paradigm. Advances in materiel tended to lead change in other areas, but there was no direct correlation of movement. Each objective manifestation was subject to the influence of several factors. Some acted directly, but the effect of most was indirect--the product of a matrix of interactions. The factors can be classified into four general types: actors, inputs, modifiers, and determinants. In the following list a brief description is offered only on those factors that are not self-explanatory. These are obviously major groups: details will become apparent in succeeding chapters. The list is not arranged in order of importance.

A. Actors.

1. Military personalities. Even in a bureaucracy individuals had impact.
2. Civilian government personalities. This includes members of both the executive and legislative branches.
3. Civilian inventors and producers of artillery materiel.

B. Inputs. These influenced the actors.

1. Threat perceptions.
2. Political considerations.
3. U.S. military technology.
4. Civilian technology.
5. Foreign military technology.
6. Foreign tactics, ratios, and organization of field artillery.

7. Tests of war. Such tests either confirmed or challenged prevailing doctrine.

C. Modifiers. Actors were influenced by other actors and inputs. The manner in which these influences were received and acted upon ultimately depended on the effect of certain modifiers.

1. The state of military professionalism. The effect of this factor, both in individual cases and in general, is difficult to isolate; however it cannot be ignored.
2. The formal military decisionmaking process. It assigned certain decisions to specific individuals within the military bureaucracy.
3. Civilian government decisionmaking process.

D. Determinants. The chain of input, actor, modifier, influenced the manifestations of the doctrine. However, a portion of the influence flowed through two uniquely important factors. To a considerable extent, these factors determined the rate of change within the paradigm.

1. Funding.
2. The status of American maneuver artillery technology.

Figure 6 shows many, but certainly not all, of the lines of influence among the factors. Although the display is crowded, it is no more than a simplistic portrayal of a complex phenomenon. It cannot reflect the multitude of qualifications needed to completely describe the system. The figure is offered as a guide to the many relationships that will appear among the factors in succeeding chapters.

Within the system, the flow of influence could take several

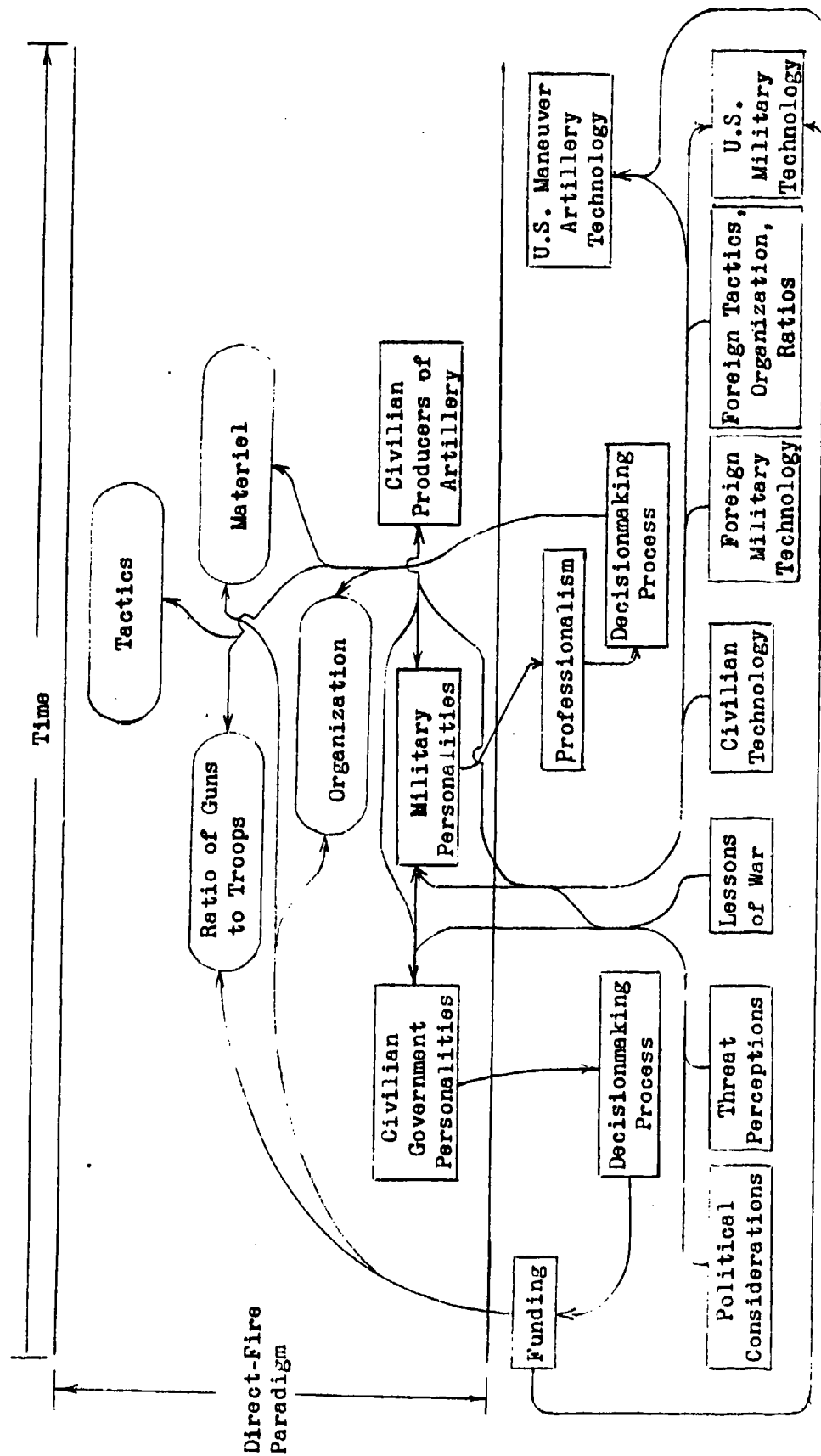

FIGURE 6
THE PARADIGM AND THE INTERACTIONS OF FACTORS

tracks. The principal flow began with any of several inputs as perceived by Army personalities within the decisionmaking process. The flow then proceeded through civilians in the national decisionmaking system. It was finally through the effects of funding and the advance of maneuver artillery technology that the flow emerged to influence the manifestations of the doctrine. Of course, along the path, various inputs and modifiers added their effects. This was only the principal path of influence. For instance, from beyond the official flow, officers outside of the decisionmaking process and civilian inventors appealed at times to both military and civilian leaders in efforts to initiate their own ideas.

It should be noted that although funding was of substantial importance, it was not a factor in all decisions. In some, either it had no effect at all or it was so submerged by other issues that its influence was negligible.

Also, it should be noted that, in general, there was influence through the civilian decisionmaking process on all manifestations of the doctrine except specific tactics. This tended to remain an area of purely military interest. However, civilian decisions did have indirect influence on tactics through their effects on other elements.

An important aspect of the operation of the direct-fire paradigm was the constraining effect that the concept had upon the actors. Through the actors, particularly those in the Army, the paradigm influenced some of the other factors. Field artillery technology particularly felt the impact of the paradigm. On the other hand, civilian technology was only remotely and indirectly touched by it, if at all. Because of its effect on the actors, the paradigm tended to perpetuate

itself.

Wars tested the paradigm. It was not necessary that American forces participate in the conflicts. American actors, principally military officers, read reports of foreign battles. Field artillery participated in strength in some fights; in others, for a variety of reasons it was hardly used. But in all cases, the principal receptors of the lessons, the military actors, were under the influence of the paradigm which tended to constrain their perceptions. This situation continued until the body of technology necessary to support an indirect-fire system was available. When that time arrived, a test of war soon brought forth the new paradigm of field artillery employment.

To go into greater detail at this time would be to steal some of the history from succeeding chapters. It is intended that the contents of these last few pages serve only as an aid to understanding for the reader. When leave was taken from the chronology of this study, the Civil War had just ended.

CHAPTER III

THE POSTWAR ARTILLERY

There was little progress in the concept of American field artillery employment in the decade after the Civil War. Tactics remained static; materiel changed only slightly; provisional tactical organizations above the battery ceased to exist; and the size of the field artillery with respect to the rest of the Army actually declined for a few years.

The end of the war left the Regular Army with the task of occupying the South. The authorized postwar Army contained nineteen regiments of infantry, six of cavalry, and five of artillery. The composition of the Army was unsuited for the responsibilities of the Reconstruction; therefore, it was reorganized and augmented in 1868¹ by the addition of twenty-six regiments of infantry and four of cavalry. The number of artillery regiments remained unchanged; there was little requirement for cannons in Reconstruction duty.

During the war, many of the foot artillery companies of the Regular Army had served as field batteries. They turned in their horses and regained their heavy guns when hostilities ended. This provided each of the five artillery regiments with ten companies of heavy weapons² and two batteries of field guns. The ten field batteries were scattered at several garrisons. Most of the foot artillery companies went to coast fortifications. The companies of the First Regiment occupied posts from Connecticut to New Jersey; those of the Second went to the Pacific

shore; the Third defended from Maine to Rhode Island; the Fourth protected Delaware and Maryland; the Fifth was split between Fort Monroe,³ Virginia, and the Florida Keys.

The Union Army emerged from the war with a wide variety of artillery. Table 1 is a list of service models of both field and foot artillery in the inventory of the Army. The War Department standardized the armament of the field artillery by providing each regiment with one battery of four 12-pounders and one battery with four 3-inch rifles.⁴ The field artillery weapons shown in table 1 as being in the hands of troops included those that were issued to the light batteries, distributed to the Militia, in post storage, or accounted for in some other way. While there were only two types of artillery in the light batteries, there was a much greater variety of weaponry in the foot companies. They were equipped with smoothbore and rifled weapons of several models and calibers. In general, coast fortifications were fully manned, which accounts for the disparity between the great number of heavy weapons and the relatively small number of foot companies.

In 1866, the War Department took a major step when it established a permanent Artillery Board ". . . , to which questions pertaining to the Artillery arm of service may be referred by the Secretary of War,⁵ or the General-in-Chief, for discussion and recommendation." The board was encouraged to take the initiative in making recommendations.⁶ As a result, it had the potential of becoming an effective voice for the Artillery within the War Department. It was composed of four artillery officers; the senior member was Lieutenant Colonel H. J. Hunt of the 3d Artillery.⁷ Since there was no Chief of Artillery for the peacetime Army, Colonel Hunt's appointment was the closest that his branch came to

TABLE 1

SERVICE ARTILLERY IN THE INVENTORY OF THE U.S. ARMY, 1868*

Weapon	With Troops	In Arsenals and armories	Total
<u>Field guns and howitzers</u>			
Smoothbore			
6-pdr. bronze guns, 3.67-inch bore	99	372	471
12-pdr. bronze guns, 4.62-inch bore	81	1,034	1,115
12-pdr. bronze guns, heavy, 4.62- inch bore	23	26	49
12-pdr. bronze mountain howitzers, 4.62-inch bore	101	203	304
12-pdr. bronze field howitzers, 4.62-inch bore	49	215	264
24-pdr. bronze field howitzers, 5.82-inch bore	11	47	58
32-pdr. bronze field howitzers, 6.4-inch bore	4	13	17
Rifled guns			
10-pdr. Parrott, iron, 2.9-inch bore	8	123	131
10-pdr. Parrott, iron, 3-inch bore	2	412	414
3-inch wrought-iron, 3-inch bore	61	752	813
20-pdr. Parrott, iron, 3.67-inch bore	8	279	287
<u>Siege, garrison, and sea-coast guns</u>			
Smoothbore			
12-pdr. cast-iron guns, 4.62-inch bore	44	11	55
18-pdr. cast-iron guns, 5.3-inch bore	54	35	89
24-pdr. cast-iron guns, 5.82-inch bore	319	288	607
32-pdr. cast-iron guns, 6.4-inch bore	600	297	897
42-pdr. cast-iron guns, 7-inch bore	129	79	208
8-inch columbiad, cast-iron	314	37	351
8-inch Rodman guns, cast-iron	198	41	239
10-inch columbiad, cast-iron	81	35	116
10-inch Rodman guns, cast-iron	1,289	10	1,299

TABLE 1-Continued

SERVICE ARTILLERY IN THE INVENTORY OF THE U.S. ARMY, 1868*

Weapon	With Troops	In Arsenals and armories	Total
<u>Siege, garrison, and sea-coast guns</u>			
Smoothbore			
13-inch Rodman guns, cast-iron	2	-	2
15-inch Rodman guns, cast-iron	293	2	295
20-inch Rodman guns, cast-iron	1	-	1
24-pdr. flank-defence howitzers cast-iron, 5.82-inch bore	458	113	571
8-inch siege howitzers, cast-iron	37	206	243
8-inch sea-coast howitzers, cast- iron	46	56	102
10-inch sea-coast howitzers, cast-iron	-	10	10
Rifled guns			
4.2-inch siege, cast-iron	4	-	4
4.5-inch siege, cast-iron	34	59	93
12-pdr. cast-iron, 4.62-inch bore	3	1	4
18-pdr. cast-iron, 5.3-inch bore	-	1	1
24-pdr. cast-iron, 5.82-inch bore	148	77	225
32-pdr. cast-iron, 6.4-inch bore	208	88	296
42-pdr. cast-iron, 7-inch bore	150	82	232
8-inch Rodman guns, cast-iron	3	-	3
10-inch Rodman guns, cast-iron	1	-	1
30-pdr. Parrott, cast-iron, 4.2- inch bore	51	321	372
100-pdr. Parrott, cast-iron, 6.4- inch bore	136	58	194
200-pdr. Parrott, cast-iron, 8- inch bore	54	28	82
300-pdr. Parrott, cast-iron, 10- inch bore	28	11	39
Mortars			
24-pdr. Coehorn, bronze, 5.82- inch bore	34	194	228
8-inch siege, cast-iron	8	27	35
8-inch siege, Rodman, cast-iron	10	160	170
10-inch siege, cast-iron	53	49	102
10-inch siege, Rodman, cast-iron	8	129	137
10-inch sea-coast, cast-iron	19	16	35
10-inch sea-coast, Rodman, cast-iron	16	8	24

TABLE 1-Continued

SERVICE ARTILLERY IN THE INVENTORY OF THE U.S. ARMY, 1868*

Weapon	With Troops	In Arsenals and armories	Total
<u>Siege, garrison, and sea-coast guns</u>			
Mortars			
12-inch sea-coast, cast- iron	2	-	2
13-inch sea-coast, cast- iron	2	-	2
13-inch sea-coast, Rodman cast-iron	8	48	56
16-inch stone mortars, bronze	1	2	3

SOURCE: U.S., Congress, House, Ordnance and Ordnance Stores,
Mis. Doc. No. 152, 40th Cong., 2d sess., 1868, pp. 2-3.

NOTE: *Does not include experimental weapons.

8
having a single voice in Washington.

A major accomplishment of the Artillery Board was the reestablishment of the Artillery School at Fort Monroe, Virginia. The school had operated in the 1820's and 1830's. It was closed in 1835 to meet the manpower demands of the Seminole War. Although there was a short-lived effort to reopen it just before the Civil War, the school remained closed until 1868, when the board set it in motion for a long period of unbroken service.⁹
¹⁰

The school was an independent command that reported directly to the General-in-Chief in Washington. The senior officer at Fort Monroe commanded the post and the school.¹¹ The first Commandant was Colonel William F. Barry, the highly capable officer who had organized McClellan's artillery.¹² Barry was given a staff of instructors to include an ordnance officer. Five companies of foot artillery supported the school. The students were second lieutenants and selected enlisted men. They were given a year of instruction before proceeding to other assignments.¹³

Instruction at the Artillery School was comprehensive. For officers it included gunnery, mathematics, the construction of artillery, military engineering, and surveying. In addition, students attended classes on the organization and duties of their branch in campaigns and sieges. Lectures on military history and law rounded out the program. Enlisted men were given instruction in mathematics, history, geography, reading, writing, and the employment of artillery.¹⁴

The school was important for the education that it provided; but more significantly, it was a place to nurture the thoughts of artillerymen about their arm. In the 1870's, the school began to require creative

essays on military subjects from officer students. In addition, after a decade of operation, it started to publish technical manuals on matters of interest to the Artillery.¹⁵ The school was a major advance in professionalism for the branch.

The school was oriented on training in heavy artillery. There was some education in the construction of field guns and the tactics of their employment; but primary emphasis was on heavy weapons.¹⁶ There was complacency in evidence in the Army with respect to the field batteries. For many years, instruction in field artillery had been decentralized to the light batteries at their various posts. In 1869, the Secretary of War initiated a project to establish a school for the light artillery at Fort Riley, Kansas. Among other objectives, the school was organized to provide a source for the achievement of uniformity in tactics and the generation of recommendations on the improvement of field artillery materiel. Four batteries assembled at Fort Riley, but before the school could begin to function, they were converted to cavalry and reassigned to frontier duty.¹⁷ The demand for cavalry in the Indian Wars strangled the nascent school and reduced the already small field artillery force.

At the same time that the Army initiated the short-lived light artillery school at Fort Riley with four batteries, it dismantled five others. Two of those that lost horses retained their light guns; the remaining three lost guns as well as beasts and reported for duty as heavy artillerymen. After the four units at Fort Riley were converted to cavalry, there remained only one battery that was both mounted and equipped as field artillery.¹⁸ The closing of the light artillery school and the conversion of several batteries to either cavalry or

coast artillery were evidence of the relatively low priority of field guns in the years that immediately followed the Civil War.

There was, however, one bright spot for the field artillery: light batteries had been spared. reduction in strength in 1867. Companies of foot artillery and infantry were reduced to the minimum number of personnel allowed by law, while the cavalry and field artillery were exempted.¹⁹ Of course, the common denominator between these last two was horses. Those valuable animals needed continuous care, and a reduction in personnel would have degraded the attention that the horses received.

In the years that immediately followed the war, the major accomplishment of the Artillery was the establishment of the school at Fort Monroe. It was a significant step toward increased professionalism within the branch, but beyond that, nothing much was done. There was a tendency in the Artillery, and in the Army in general, to rest upon the accomplishments of the recent war. Colonel Barry found that some of his students who had seen active service in the field ". . . were not well inclined to submit to the hard study and sacrifice of personal leisure which a tour of duty at the school demanded."²⁰ Even the "permanent" Artillery Board found no further work after its first year; it was adjourned and never reassembled. As a result, the Artillery lost²¹ its voice at the War Department.

In the area of tactics, there was some consolidation and digestion, during the postwar period, of recent experiences. But before continuing with a review of what was done, it is necessary to explain the term "tactics" in its mid-nineteenth-century context.

It meant, as it does today, the manipulation of combat resources

on the battlefield; however a century ago, there was an additional dimension to the word that has been lost with time. The old meaning of tactics was broad; it encompassed the employment of infantry, cavalry, and artillery in combat; ²² but it also referred to the close-order drill necessary to achieve the symmetrical battlefield deployment practiced by the armies of a hundred years ago.

In fact, a survey of old manuals reveals that far more attention was given to drill than to other aspects of tactics. Few motions were too insignificant to escape description in print; for example, the number-one man in an artillery crew:

. . . casts his eyes toward the vent to see that it is closed, inserts the sponge, drops the left hand behind the thigh, shoulders parallel to the piece, feet equally turned out, straightens the right knee, and, bending over the left, forces the sponge home.²³

Instructions for the drill of echelons above the soldier were given with similar attention to detail. Figure 7 is an example of a battery maneuver.

Each of the combat branches subscribed to its own particular manual of tactics; and as a rule, relatively few pages were devoted to combined-arms operations. Books by a variety of authors, both domestic and foreign, were available on the broader aspects of tactics; "the theory of war" was a descriptive term sometimes associated with such works. However, it was not until 1892 that the United States Army ²⁴ published its own combined-arms manual, Troops in Campaign.

Only a handful of Americans have become recognized as military thinkers; Emory Upton was one such theorist. At the beginning of the Civil War, he was graduated from the Military Academy and commissioned in the Artillery. He was one of those talented officers who soon left the branch to take a higher commission with the volunteer infantry. He

FIGURE 7

MOUNTED BATTERY IN OBLIQUE MARCH

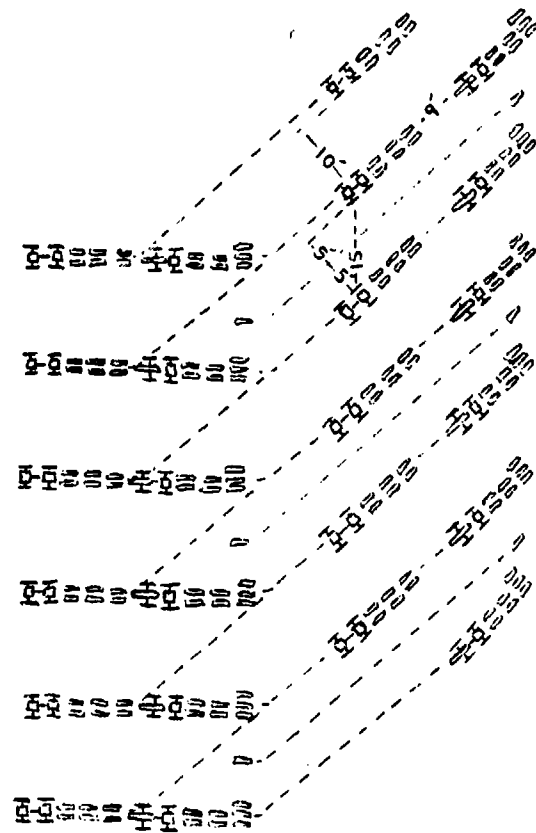

SOURCE: William H. Frank, William F. Barry, and Henry J. Hunt, Instruction for Field Artillery (Washington, D.C.: Government Printing Office, 1864), plate 47

emerged from the war a brevet major general and an acknowledged expert on infantry tactics. Upton remained with the Infantry until 1870, when he transferred with the Regular Army rank of lieutenant colonel back into the Artillery.²⁵ However, his contribution to American tactics was limited to those of his adopted branch, the Infantry. It is interesting to speculate about the benefit that might have accrued to the Artillery had it been able to continually retain the services of this talented officer.

At war's end, Upton began work on a manual of infantry tactics. In 1867, he commercially published A New System of Infantry Tactics Double and Single Rank Adapted to American Topography and Improved Fire-Arms. The manual was more than just another drill regulation; Upton's advocacy of extended-order formations was a substantial advance in concepts of infantry development.²⁶ However, aside from its conceptual achievement, like other tactical manuals of that transitory age, it contained much drill-like instruction.

The publication of Upton's manual prompted the calling of a series of boards to consider the revision of tactics throughout the Army. The first of these was headed by General Ulysses S. Grant. The Grant Board recommended that Upton's tactics be formally adopted for the Infantry, an action approved by the Secretary of War in 1867.²⁷ A year later, a board assembled under Colonel William Barry at Fort Monroe, Virginia, to devise a system of field artillery tactics that would ". . . , as far as possible, conform . . . to the present system for the Infantry . . ." ²⁸ And in 1869, a third board was ordered to assemble under Major General John M. Schofield ". . . , to practically test the systems of tactics heretofore adopted for the Artillery, Cavalry, and

Infantry . . . ; to reconcile all differences; . . ." ²⁹ These were important boards, and they attracted much attention within the service.

The Barry Board was principally concerned with artillery; however, it did little more than confirm the obvious experiences of the last war. With respect to the ratio of field pieces to troops, the board held that in broken and wooded terrain a minimum of 1 gun per 1,000 men and a maximum of 2 was all that was required; in open country, the proportion might go to 4 per 1,000. In the area of organization, the board confirmed the wartime expedient of assembling two or more batteries under a field grade officer, but it dropped Hunt's old pretense of calling them a "brigade," using instead the designation "battalion." The term "brigade" was reserved to the assembly of two or more battalion-sized units under the command of either a senior field-grade officer or a brigadier general. The board displayed a continuing faith in short-ranged artillery when it specified that on a wartime footing the guns of four batteries out of every seven were to be smoothbores; of the remaining three, two were to consist of rifles, and one was to contain Gatling guns--a new addition. In 1864, Grant disbanded the Artillery Reserve, but the concept was still alive and well four years later among the officers that worked with Barry, ³⁰ and they included it in their draft manual of tactics. One significant observation that can be made about the work of the board is that there was an absence of any consideration of high-angle fire. It is evidence that the direct-fire concept of field artillery employment continued to prevail in American military thinking.

The boards headed by Barry and Schofield, however, had not really been called to consider doctrinal change. The instruction given

to Barry to conform to the present system of the Infantry and the charter given to Schofield to reconcile the tactics of all three combat branches referred primarily to drill, commands, and bugle signals. And Schofield found that much work was needed to bring all arms into line in these matters. ³¹ The point is that although postwar boards met to consider the subject of artillery tactics nothing of substance was done with respect to doctrinal change.

Such was the state of affairs in the Artillery as of 1870. The field artillery, in particular, was in a condition of stagnation. As an active organization it had nearly ceased to exist. The paradigm of direct-fire field artillery support for the maneuver army was still very much in effect. Any major change within the paradigm would be tied to the technological evolution of artillery materiel, and the responsibility for weapons development lay not with the Artillery, but with the Ordnance Department. It is necessary to drop back in time for a close look at this agency of change.

CHAPTER IV

THE NATURE OF THE PRINCIPAL AGENCY OF CHANGE

At the end of the Civil War, the Chief of Ordnance, Brigadier General Alexander B. Dyer, proposed that attention be given to the arma-
ment of coast defenses. ¹ The difficulty of the trench was largely forgotten; there was no apparent answer for it; the war that had produced it was over; and it was time to get on with other things. Quite reasonably, Dyer identified what he considered to be the most probable future threat--foreign naval power. He did not totally neglect field artillery, but he concentrated his attention upon the development of heavy seacoast guns. Field artillery benefited in a tangential way; as time passed, ordnance engineers transferred to lighter guns some of the technological advances that had been generated for heavy weapons.

When General Dyer made his recommendation, he was operating as part of the nineteenth-century decisionmaking process that determined the direction of American military technology. The process was rather diffuse. The Ordnance Department played a principal role, but it was assisted, and sometimes supplanted, by a myriad of special officer boards and congressional committees. To understand the interrelations and relative roles in the decisionmaking process one must know something of the principal participants.

The Ordnance Department was created by the Act of 14 May 1812. During the Revolutionary War, ordnance functions had been performed by the Board of War and Ordnance, a permanent committee of five members of

the Continental Congress. In 1784, the Commissary General of Military Stores absorbed ordnance responsibilities only to lose them eight years later to the Treasury Department. Actually the responsibilities were divided; procurement and supply belonged to the Treasury Department, while the design and construction of artillery materiel was assigned for a brief period to the Artillery. Just before the War of 1812, the Ordnance Department was created and charged with the inspection, proof, and supply of weapons and ammunition. In 1815, the Department was given greatly expanded duties, to include the management of arsenals, the procurement of arms and ordnance stores, and the prescribing of standard equipment. ² In effect, the Ordnance Department was given sole responsibility for the development and selection of artillery materiel. However, in December 1820, Secretary of War John C. Calhoun proposed to Congress that the Ordnance Department be merged with the Artillery in order to involve artillery officers in the materiel acquisition process. Three months later, Congress combined the two branches. But the lawmakers went further than Calhoun had anticipated; the Secretary wanted to leave eleven of the Department's forty-four authorized officers on permanent ordnance duty, but the Senate would approve only four; all other positions were to be filled by artillery officers rotating through ordnance assignments. What was left of the Ordnance Department persevered through eleven years of the alliance. The rotation of artillery officers prevented an accumulation of the specialized talent that the Colonel on Ordnance Duty thought necessary; and, in 1827, he appealed to Congress to revise the system. Five years later, Congress ³ restored the Ordnance Department to its separate status. After the separation, the Department began to grow, and, in 1861, the Chief of

4

Ordnance was advanced to the grade of brigadier general.

The Ordnance Department enjoyed two organizational advantages over the Artillery. First, in the years that followed the war, the Chief of Ordnance continued to hold general officer rank. In contrast, the highest artillery command was that of regimental colonel; there were five such positions. Since the Artillery had no single spokesman it was at a disadvantage with respect to the Ordnance Department in the politics of intraservice rivalries. Second, the artillery regiments were part of the Army of the Line, along with the Infantry and Cavalry. They were subordinate, through territorial commands, to the Commanding General of the Army.⁵ On the other hand, the staff agencies, of which the Ordnance Department was one, were under the direct supervision of the civilian Secretary of War.⁶ As a result, the senior officer of the Army did not have the authority to intercede in technical matters within the Ordnance Department. The effect was that, for many years, the Department enjoyed near autonomy in the design and selection of weapons. Chiefs of Ordnance learned to guard their prerogatives with zeal.

The Ordnance Department played a principal role in the technological evolution of artillery, which is not to say that artillery was its sole concern. To the contrary, the Department was responsible for the procurement and development of weapons, ammunition, and related equipment for the entire Army. The many demands on the attention of the Chief of Ordnance, combined with his independence from military supervision, accentuated his importance in the decisionmaking process. The use of one office to supervise ordnance development for the entire Army was an advantage in that it had the potential of assuring a balanced program of acquisition; but inherent in that advantage was its

antithesis--that should the Chief of Ordnance tilt in one direction, there would be no influence to right him except the Secretary of War. The situation just described might have been particularly dangerous for the Army had it not been for the tradition of the board of officers.

The Army habitually assembled boards of officers for the purpose of investigating and making recommendations on special projects, such as the writing of field manuals and the selection of new weapons. Boards varied in their permanency, some were assembled for a single purpose, others might continue for years on a series of related projects. In the field of ordnance development, boards were convened on several levels, some were internal to the Ordnance Department, others were called at the direction of the Secretary of War, and occasionally Congress would require the establishment of a board. The system of boards, particularly those external to the Ordnance Department, provided a means for other branches and staff agencies to be heard on ordnance related matters. For example, on the instructions of the Secretary of War, a board of ordnance, artillery, and engineer officers convened in 1867 to select types and numbers of cannons for seacoast fortifications. ⁷

The armament of coast fortifications was an issue of growing national interest; and it became the practice of Congress to direct the formation of multibranch boards to consider questions of such high visibility. But the great majority of developmental issues were resolved within the Ordnance Department without recourse to opinion from other branches. The Ordnance Board had operated since 1841 as a principal advisor to the head of the Department on inventions, experiments, and improvements in materiel. It was an agency organic to the Ordnance Department and as such, it functioned with a degree of harmony that did

not always prevail during the meetings of mutibranch boards.

Ultimately, of course, any decision on ordnance development and procurement was meaningless until it was sanctioned by the fiscal action of Congress. The lawmakers did not make it a practice to become intimately involved with technical details. However, they did not hesitate to delve deeply into controversial issues that attracted national publicity. But the majority of development and procurement drew little publicity. The Chief of Ordnance enjoyed a significant amount of discretion in the employment of public funds. When he submitted his budget, a selective process had already taken place; he had determined the amount to be allocated for each project; and although Congress might add or, more likely, cut funds, the initial request strongly determined the relative amount finally allocated to any one particular weapons system. Of course, the discretionary fiscal powers of Congress were absolute, and at times, the relative priorities of the Ordnance Department were significantly altered, all of which made the legislative body an important participant in the decisionmaking process.

In summary, the process was one in which the Chief of Ordnance, a collection of officer boards, and occasionally, congressional committees, all played roles. The Chief of Ordnance was at the center of the process, although his actions and the recommendations of the various boards were ultimately subject to the approval of the Secretary of War and the great discretionary power of Congress. These influences would combine in various degrees to provide direction to the course of the development of American artillery.

In 1865, when the Chief of Ordnance, Brigadier General A. B. Dyer, recommended that attention be given to coast defenses, he started the

postwar decisionmaking process that was to give technological development of artillery a particular direction. Ships were the target of coast artillery; therefore, the effective engagement of ships was the goal that drove coast artillery development. Guns had to be quite large in order to exchange fire with ships of the line, simply because the ships themselves carried cannons of significant size and range, and also because the increasing use of naval armor demanded guns of greater power. This led to emphasis on the development of heavy artillery which was large and immobile and, therefore, quite unlike the light artillery of the field batteries.

Dyer was probably the most controversial officer to ever serve as Chief of Ordnance. By his own actions, he was responsible for some of the controversy; but it was not all Dyer's fault; his position was inherently sensitive. His duties included the awarding of contracts to civilian producers of artillery materiel. The potential for discontent and recriminations among disappointed applicants was high. To this must be added the volatile political atmosphere that prevailed at the end of the war. Some Congressmen were ever ready to seize upon and to exploit any charge of malfeasance within the Federal Administration. The total effect of these distractions upon weapons development is impossible to measure; however, it can be said with some assurance that the controversies that boiled around Dyer certainly reduced the potential for efficiency within the Ordnance Department.

Dyer was the third officer during the Civil War to hold the position of Chief of Ordnance. His predecessors, Brigadier Generals James W. Ripley and George D. Ramsey were both the recipients of criticism for their handling of the Department. Ripley was very conservative

in the adoption of new weapons, and Ramsey had the misfortune of incurring Secretary of War Edwin Stanton's ill will. Ramsey held the job for only one year. In September 1864, the commander of the Springfield Armory, Major A. B. Dyer, was appointed in his place.

Twenty-seven years earlier, Dyer had been graduated from West Point and commissioned in the Artillery. He served in the branch only a year before transferring to the Ordnance Department. In 1864, he had been a major for a year when he was advanced past more senior members of the Department to the position of Chief and the rank of brigadier general.

Dyer was a capable officer, but he assumed his position at a difficult time. In January of 1864, not long before Dyer took office, the Committee on the Conduct of the War, a Congressional committee of Radical tendencies, had begun an investigation to:

". . . inquire into the character and efficiency of the heavy ordnance now provided for the armament of fortifications; . . . ; the amount of 'royalty' paid, and to whom, . . . ; the tests to which these guns are subjected; what proportion of our sea and land armament is of rifled ordnance; when rifled guns were introduced, and the cause of the delay pertaining thereto."¹⁴

The declared purpose of this yearlong investigation displays a measure of suspicion and dissatisfaction over the conduct of the business of the Ordnance Department. It was Dyer's misfortune that he inherited the Department in an atmosphere of growing congressional displeasure.

In part, the investigation was caused by reports of the hazardous operation of some Union heavy artillery. During the war, 129 heavy guns burst in service (see table 2). Parrott guns, used by both the Army and the Navy, had the worst record; a total of 83 failed unexpectedly. In the naval attack on Fort Fisher, 42 sailors were killed or wounded by exploding guns. In comparison, the losses to enemy action

TABLE 2

SUMMARY OF UNION HEAVY ARTILLERY BURST DURING THE WAR

Weapon	Number
Parrott 100-pounders (rifles) (CI, WI breech-band)*	60
Parrott 150-pounders (rifles) (CI, WI breech-band)**	22
Parrott 10-inch (rifles) (CI, WI, breech-band)***	1
Parrott 30-pounders (rifles) (CI)	3
Rodman 12-inch (rifles) (CI)	4
Rodman 8-inch (rifles) (CI)	2
Rodman 15-inch (smoothbores) (CI)	17
Rodman 13-inch (smoothbores) (CI)	1
Dahlgren 150-pounders (rifles) (CI)	3
Dahlgren 80-pounders (rifles) (CI)	2
Dahlgren 50-pounders (rifles) (CI)	1
Dahlgren 30-pounders (rifles) (CI)	2
Dahlgren 13-inch (smoothbore) (CI)	1
Dahlgren 11-inch (smoothbore) (CI)	1
Miscellaneous wrought and cast-iron cannons	9
	Total <u>129</u>

SOURCE: U.S., Congress, Senate, Report, Rep. Com. No. 266, 40th Cong., 3d sess., 1869, p. 217.

NOTES:

*CI=Cast-iron, WI=Wrought-iron.

**Naval designation for 200-pounders.

***The 10-inch rifle was a 300-pounder.

were minor. It was a serious problem; naval gunners feared some of
their own weapons more than those of the Confederates. The Army
also had a problem with heavy artillery failures. Major General Quincy
A. Gillmore, in command of the siege of Charleston, told a congressional
committee that 23 of his heavy guns burst during a six month period.
Gillmore estimated that the large Parrott guns were able to stand an
average of only 310 rounds before failing. This was well below the
expected life of 1,000-1,200 rounds for heavy artillery.

It was a slightly nervous Parrott that came to testify before
the Senate committee. He wanted to leave no doubt as to his motives;
he was quick to point out that his 10-, 20-, and 30-pounders had pro-
vided excellent service to the Union; and to underline his patriotism,
he made it clear that he had not raised the prices of these guns
although the cost of material had increased greatly.

The problem, however, was with Parrott's big guns; and he
expressed understandable concern over their hazardous performance. He
postulated that the trouble was with the shells rather than the cannons.
As it happened, he produced the shell casings, and the government filled
them with powder. Perhaps Parrot's assertion was an attempt to avoid
full blame, but it was as plausible at the time as any explanation. But
others thought that the guns rather than the shells were at fault.
Major Thomas J. Rodman told the committee that the wrought-iron band
that reinforced the cast-iron breech in the Parrott design tended to
separate at every firing. The result, according to Rodman, was the loss
of the protection of the reinforcing band and the subsequent destruction
of the gun. The point is that the science of adopting both rifling
and wrought iron to heavy artillery was quite new and unsettled.

Part of the problem with Parrott's heavy guns can be traced to the rushed procedure that attended the acquisition of the weapons. Parrott offered the first 100-pounder to the government in the fall of 1861. Immediately, Captain Stephen V. Benét, an inspector of ordnance at the West Point Foundry, was ordered to test the weapon in conjunction with the Navy. The gun was fired a thousand times without failing. The success of the initial test and the good reputation of the smaller Parrott models, combined with the emergency created by the war, generated a rapid order for more of the 100-pounders. ²¹ The difficulty was that the guns were not uniformly reliable. A less rushed acquisition might have exposed the weakness of the 100-pounders before they were put into the hands of servicemen.

Although the committee was concerned about the bursting of heavy artillery, it dealt rather mildly with the matter. It leveled no charges and apparently damaged no careers, least of all that of Captain Benét, the officer who tested the first 100-pounder; he later became Chief of Ordnance.

The issue that really concerned the committee was why the ordnance agencies purchased particular types of heavy artillery to the exclusion of others. From the record of the investigation, it is apparent that the lawmakers were trying to determine if certain inventors enjoyed unwarranted preferential treatment in the procurement of heavy guns. At the time, two names dominated the field of Army heavy ordnance: Rodman and Parrott.

Major Thomas J. Rodman was an ordnance officer of great creative ability. He was a young man, just four years out of West Point, when in 1845, he developed the principle of initial tension in cast-iron

22
gun construction. Rodman's idea was stimulated by the tragic bursting of a large gun on the steamer Princeton a year earlier. He became convinced that the prevailing method of cooling newly cast guns set up strains within the metal that invited future rupture. At that time, guns were cast as solid pieces; bores were drilled later. In this method of casting, cooling began with the outside and proceeded into the inside of the metal. Guns cooled from the exterior, reasoned Rodman, compressed the interior metal, establishing permanent, adverse strains that were intensified when the cannon discharged. Rodman's solution was simple; he envisioned casting guns with hollow bores and then cooling the metal from the inside. 23 This, he felt, would cause each successive layer of metal to shrink onto the one before it, in much the same way that rims were shrunk on wheels. The result would be an even, permanent compressive force throughout the depth of the metal that would give additional strength to the cannon barrel. 24

Rodman tried three times to interest the Ordnance Department in his process. He offered it to Lieutenant Colonel George Talcott, who was acting Chief of Ordnance; and later, in 1846, he approached the head of the Department, Colonel George Bomford. In both instances, he was rebuffed. Rodman then took his idea to Charles Knap, a civilian proprietor of the Fort Pitt Foundry near Pittsburgh. Knap thought that the plan had merit. Rodman returned to Washington, found Talcott, and tried once again to interest the Department in his idea. Rebuffed the third time, he asked Talcott if there would be any impropriety in securing a patent and turning the idea over to private enterprise. Talcott, seemingly glad to be rid of the bothersome lieutenant, said, "Certainly not." Soon afterwards, Rodman entered into an agreement with

Knap whereby he yielded one half of his interest in the patent to the
25
manufacturer.

After several more years of development, the idea was a remarkable success. In 1859, Secretary of War John B. Floyd was sufficiently impressed to order that all heavy cannons for land service be cast on the Rodman principle. It is interesting that he acted without the recommendation of the Ordnance Board. However, the Department fell into line and began to purchase the weapons. The introduction of Rodman guns was given a boost in 1861 when a mixed board of artillery and engineer officers met to consider the armament of coast defenses. They concluded that the introduction of armored warships demanded guns of at least 8-inch caliber. The great majority of coast artillery was well below that requirement. An ordnance board that included Major Dyer and Captain Rodman then recommended that the required guns be cast on
26
the Rodman principle. During the war, the principle was used in the construction of substantial numbers of guns in sizes of 8-, 10-, and 15-inch. By the end of the conflict, the Ordnance Department had become fully committed to the Rodman design for heavy artillery.

In the context of today's bureaucratic morality, Rodman's service on the 1861 board may seem to be a case of conflict of interest. At the time, however, restrictions on such matters were not clearly defined. However, it was an unfortunate situation, because Rodman's association with the Ordnance Department offered detractors the suspicion that he was engaged in collusion to further his own interests. His participation on the board did nothing to allay those suspicions. In addition, Dyer's early and long association with Rodman was a situation that would return to haunt the former when he assumed responsibilities

for making decisions on heavy weapons as the new Chief of Ordnance.

The second major contributor to Army heavy ordnance was Robert Parker Parrott. He has already been introduced in these pages; however, this interesting man deserves a closer look. Parrott was commissioned in the Artillery in 1824. He soon changed his branch to Ordnance. In 1836, he resigned from the service with the rank of captain. For the next thirty-one years he was superintendent of the West Point Foundry.²⁷ His relatively cheap and easily produced design for rifled artillery helped to fill the rapidly expanding Union need for guns. The fame of his smaller artillery was uncontested; however, the tendency of his larger calibers to burst made him a controversial contributor to the ordnance of both the Army and Navy. He put a great amount of faith in the supposed strength derived from banding the breech of a cast-iron cannon with wrought iron. He cast the barrels by the old solid-core method. It was not until late in the war that he began to employ the Rodman principle of casting, in addition to the wrought-iron band, in the construction of heavy artillery.²⁸ Although his service with the Ordnance Department ended in 1836, like Rodman he was vulnerable to implications that his success in selling guns to the Army was more the product of cronyism than merit.

The Committee on the Conduct of the War took a hard look at the money paid to Rodman and Parrott. Rodman had yielded the half interest in his patent to Knap three years earlier in exchange for a payment of 1/2¢ per pound for all subsequent castings; and as a civilian entrepreneur,²⁹ Parrott claimed only a "fair" manufacturer's profit. These explanations did not seem to disturb this particular group of lawmakers; but congressional interest in the money paid to Rodman was by no means

over.

The propriety of military inventors holding patents on devices purchased by the government was to remain in limbo for a number of years. A military tribunal in 1868 issued the opinion that a government employee, in or out of the service, should be permitted a patent right on any invention, even though federal facilities might have been used in the creation of the device. However, there was an exception; the members of the tribunal felt that if it was the duty of the employee to make experiments to improve a specific piece of equipment, then the government should have the right to use the invention without further compensation. In Rodman's case, the tribunal implied that he qualified for a patent.³⁰ The military court's opinion was not a definitive resolution of the patent problem; and, of course, its interpretation was not available to the Senate committee in 1865.

The question of patent rights aside, the Senators thought that it was time to depart from heavy guns constructed of cast iron. Virtually all American heavy artillery was made of the material. The committee acknowledged that the Rodman guns were among the best smooth-bore, cast-iron pieces in any service. But they thought that rifled artillery was needed, and the adoption of rifling in large cast-iron guns had been less than successful, as evidenced by the poor record of the Parrott weapons. The committee recommended in its report that the War Department introduce large-caliber, wrought-iron guns into service as soon as practical.³¹ Herein lay one of the seeds of difficulty that was to degrade the efficiency of the Ordnance Department as an agency of weapons development for the next fifteen years: with a steadfastness that constantly provoked the anger of its critics, the Department

would remain committed to cast iron in the construction of heavy artillery.

At the time the committee conducted its hearings, a large wrought-iron gun was available to the Ordnance Department. Horatio Ames, a New England industrial pioneer, began experimenting with the construction of wrought-iron guns about 1851.³⁸ Ten years later, the Navy Department had given him an order for five 50-pounders on an experimental basis. The price was too high, and the Navy declined to order any more.³³ However, in 1863, President Lincoln became interested in Ames' wrought-iron weapons and personally gave him an order for fifteen. He stipulated that they were to be at least 100-pounders. And if they were found to be better than service guns of similar caliber, the President promised to advise the appropriate authorities that Ames be paid at a rate of 85¢ per pound of cannon weight.³⁴ Interestingly, Lincoln wrote a subsequent memorandum which said, "If Horatio Ames will make ten wrought-iron guns after his method, which shall answer satisfactorily such tests as I shall order, I will see that he gets paid \$1 per pound for each gun."³⁵ Considering the relatively high first price of the weapons, 85¢ (Rodman guns were being purchased for 7 8/10¢ per pound),³⁶ it was a curious memo. In any event, Ames did provide fifteen 7-inch guns (125-pounders) in September 1864. Lincoln ordered a mixed board of Army and Navy officers to test the weapons at Bridgeport, Connecticut. The board included one Army ordnance officer, Major Theodore T. S. Laidley.³⁷ The first gun was successfully tested, and the board unanimously reported in October that:

. . . Ames' wrought-iron guns possess to a degree never before equalled by any cannon of equal weight offered to our service, the essential qualities of great lateral and longitudinal strength, and great powers of endurance under heavy charges; that they are not

liable to burst explosively and without warning, even when fired under very high charges; and that they are well adapted to the wants of the service generally, but especially wherever long ranges and high velocities are required.³⁸

Additional tests, at the time apparently successful, were being made on the Ames guns when the inventor testified in the closing days of the congressional committee's investigation. He stated that the price of the fifteen guns was 85¢ per pound, but that the price for additional weapons would be a dollar. His explanation was that wrought-iron weapons required much labor to produce and that the cost of both labor and material had risen. Ames estimated that he could supply a 200-pounder (about 8-inch) for \$28,000. In contrast, the largest Parrott gun, the 300-pounder (10-inch), was available for \$5,000; and the largest Rodman smoothbore, the 15-inch, was being produced for \$7,500.³⁹ In spite of the high price of the Ames weapon, the committee urged the rapid adoption of wrought-iron guns.

Dyer had assumed the responsibilities of Chief of Ordnance midway through the congressional investigations. In October 1865, nine months after the issuance of the committee's recommendations, he published his first annual report.

In that report, his emphasis on heavy artillery is clear. "The estimates [Dyer's] for the next fiscal year call for appropriations only for continuing the armament of our permanent fortifications, and for the work already begun for increasing the manufacturing and storage capacity of the arsenals, . . ."⁴⁰ However, in the appropriations for armament, the Ames gun was dropped from consideration. All rifled artillery accepted by the Department was subject to proof-tests of ten rounds. Two of the Ames weapons had burst in proof; a third, bored up to 8 inches in a separate experiment and fired twenty-four times, also failed. Dyer

announced that "The failures . . . indicate that these guns cannot be relied upon, and that no more of them ought to be made for the department."⁴¹ At the same time, he ordered the construction of all the heavy artillery carriages and cast-iron barrels that manufacturing facilities could produce.⁴² This was the beginning of a great and continuing postwar emphasis by the Ordnance Department on the development and production of cast-iron heavy artillery for coast defense.

In the five years that followed the war, the Department did a negligible amount of work on field and siege artillery. In 1866, Dyer reported that experimental wrought-iron field and siege carriages had been constructed and tested. It was certain, he said, that the new designs would replace carriages of wood.⁴³ His optimism was premature. Although the Department was not opposed to the use of wrought iron in carriages, the designs by Majors Thomas J. Rodman and James G. Benton progressed no further than the experimental stage. It was not the fault of the materiel; the Chief of Ordnance subsequently decided to ignore further effort in the area for reasons of economy; he chose to rely instead on the great glut of wooden carriages produced during the war.⁴⁴ Before the decade turned, the Department did begin the design of a 3.5-inch field gun. It was to look similar to the 3-inch piece, and it was to be constructed from either bronze or wrought iron. However, like the new wrought-iron carriages, it never got beyond the development stage.⁴⁵

There was no pressure on the Department to give any emphasis to the development of light guns. William Barry, the foremost artilleryman in the Army, felt that the proportion of rifled guns to smoothbores was already greater than necessary;⁴⁶ and in addition, he was completely

opposed to the adoption of the new concept of breech-loading (introduced to the Union Army in the Whitworth). In his words, "There is scarcely any advantage in having a field-gun load at the breech; indeed, as far as rapidity of firing is concerned, it is a disadvantage." ⁴⁷ And William T. Sherman, when he became Commanding General of the Army, stated clearly, "In field guns the experience of our late war demonstrates that we have in the Napoleon twelve-pounder smooth-bore, and in the three-inch ordnance rifled gun, all that is to be desired at this time." ⁴⁸ Neither the Ordnance Department, the Artillery, the Commanding General of the Army, nor the Congress displayed much discernable interest in the improvement of field artillery materiel. The product of all this satisfaction with the status quo was that the Ordnance Department was free to devote its energies to the development of heavy guns.

The controversy over the relative merits of wrought and cast-iron construction did not effect field artillery. The 3-inch rifle, a Department design, was made of wrought iron; and the 10-pounder Parrott had a cast-iron barrel with a wrought-iron band around the breech, both served well during the war. With the relatively small 3-inch rifle, the cost of wrought-iron construction never became an issue; and the light charges used in field artillery did not expose problems with either metal. However, not many years in the future, greater power would be demanded from light guns. By then, the issue of the best cannon metal would be solved, largely because of the requirements of heavy artillery.

The problem with heavy artillery was twofold. First, the large charges of powder used to drive heavy projectiles put tremendous explosive pressures on gun barrels; therefore, much strength was needed to

to absorb the force. The second problem was that rifling increased propellant pressures. The projectile of a rifled piece engages spiral grooves as it travels down the barrel; this causes resistance and a buildup of gas pressure as the grooves impart a stabilizing spin. Of course, the pressure can be reduced by decreasing the size of the propelling charge, and this was done; in a smoothbore, the charge was about $1/2$ of the weight of the projectile; and in a rifled piece, it was about $1/10$.⁴⁹ But the charge could only be reduced to a certain point, after that, the trade off in decreased range made rifling impractical. Therefore, in order to maintain range in heavy artillery, a great strength of metal was required to retain the propelling pressure.

Rodman had already contributed significantly to a solution of the pressure problem in big guns. In 1859, for a while, he had shifted his inventive genius from the casting of metal to the manufacture of powder. For several hundred years it had been known that gunpowder burned faster when it was coarse than it did when it was packed in a finely powdered form. The reason was simple: coarse grains were exposed to more air than packed, fine powder. Rodman decided that by carefully controlling the size of powder grains it would be possible to vary the rate of combustion. To test his hypothesis, he had the duPont Company produce six batches of gunpowder, each with a specified grain size ranging from 0.10 to 0.40 inch. The test was a success; and the Army quickly adopted "mammoth" powder for heavy artillery (0.9 to 0.6 inch), and "cannon" powder for field guns (0.35 to 0.25 inch). The larger grains exposed less surface to the air; therefore, they burned more slowly. As a result, a dangerous, instantaneous development of great pressure from a large charge of powder could be avoided without a

significant loss in total propelling force. Rodman took his investigations a step further with the introduction of the "perforated cake,"⁵⁰ which was a compressed wafer of gunpowder with holes through it. The improved design permitted increased accuracy in the control of propulsive force, but the cost of production prohibited its adoption by the Army.⁵¹ Rodman's work with powder could not by itself solve the pressure problem in heavy artillery; designers were dreaming of guns of yet greater size, and the use of rifling was adding an awesome complication.

The technical question that still faced the Ordnance Department was what metal could withstand the pressures in large artillery the best? Wrought and cast-iron construction each had weaknesses. Because of the nature of its manufacture, wrought iron could not be cast into the shape of a cannon; pieces had to be made separately and then welded together to build a barrel. The Ames gun was built primarily of concentric rings.⁵² The welds were the weakest points in the construction, and they contributed to the lack of uniform reliability of the guns under the pressures of large charges.⁵³

Cast iron had no welds; it was poured into a mold in the shape of a cannon. It did, however, have drawbacks. Castings had been known to burst spontaneously on cooling; and it was not uncommon to find cavities in the metal.⁵⁴ Dyer, responding to charges in public journals that cast-iron ordnance was worthless, found it necessary to explain in his 1867 annual report that the Department maintained high standards on the quality of metal that it would accept; and as a result, many cast-iron guns were condemned before they left the factory.⁵⁵ There was another weakness to cast iron: it was brittle. Too brittle to take

very well the pressures in large rifled weapons.

In the midst of the metal controversy, Dyer requested a board of artillery, engineer, and ordnance officers to review the needs of coast defense. They reported in 1867 that:

. . . 'there would probably be required for the permanent fortifications, in addition to the ordnance now on hand, 805 smooth-bore guns of 20, 15, and 13 inches calibre, 810 rifles of 12 and 10 inches caliber, and 300 mortars of 15 and 13 inches calibre, to be provided from time to time, as the readiness of the forts to receive armament, the capacity of the foundries for its manufacture and the appropriations applicable to its procurement may warrant.' 57

Although he realized that more time was needed to develop rifled weapons,
58
Dyer wanted to produce the cast-iron smoothbores immediately.

With good cause, one might wonder why the board recommended the purchase of such a large number of additional smoothbores in an age in which rifling was the growing attraction. The obvious reason is that the design of large rifled weapons was still fraught with difficulty. But beyond that, some officers considered smoothbores to be more efficient than rifles against ships at short ranges. Smoothbores generally had higher muzzle velocities than rifles of the same caliber. Of course, the advantage reversed at long ranges, because the velocity of the spherical projectile dropped off more rapidly than that of the elongated one. But, at ranges of 1,000 yards or less, the higher velocity of the smoothbore round contributed to its crushing effect. The
59
smoothbore Rodman guns were designed to "rack" the armor of ships--to
60
break metal by concussion. In contrast, rifled projectiles tended to penetrate, which was to be an advantage as naval armor improved.

In spite of the difference in opinion on cast-iron guns, Dyer must have felt that his standing with Congress was secure. He petitioned the lawmakers for relief from an old debt to the government. Their

reply, in 1867, was a clear indication that he could expect trouble ahead.

Six years earlier, as a captain in command of the arsenal at Fort Monroe, Virginia, Dyer had been entrusted with \$9,778.42 in public funds. He maintained that the money was held, as required by law, in the United States depository twenty-five miles away at Norfolk. Dyer's problem began when Virginia seceded. He said that he was unable to retrieve the funds after the passage of the ordinance of secession. The money was never recovered by the Union; and after the war, Dyer⁶¹ petitioned Congress for relief from responsibility.

The matter was turned over to the Military Committee of the Senate for investigation. The committee, in a harsh report that was critical of Dyer, recommended against relief.⁶² The Congressmen cast suspicion on the truthfulness of Dyer's evidence, all but charged him with negligence for not withdrawing the funds in time, and even implied that he might have converted the money to his own use.⁶³

The committee was headed by Jacob M. Howard of Michigan, a Senator placed among "the most radical type" by Representative James G. Blaine, his contemporary and author of Twenty Years of Congress.⁶⁴ Radical opposition to President Andrew Johnson's Administration had reached a vehement level by the time Dyer submitted his petition. It is impossible to determine how much, if at all, politics might have influenced the committee's decision; certainly a scandal involving Dyer would have reflected badly on the Administration.

In 1867, Dyer's difficulties were just beginning. Three months after the investigation into his loss of funds, the Select Committee on Ordnance, also headed by J. M. Howard, began hearings on the purchases,

contracts, and experiments of the Ordnance Department. The investigation lasted into 1869 and covered a wide range of Department activities. In the beginning, however, it focused on Dyer's integrity in past government purchases of artillery ammunition. The committee issued a special report on the matter, which ended with the recommendation "That the President be respectfully requested to remove Brevet Major General A. B. Dyer from the position of Chief of Ordnance"

66

The recommendation was based on the accusation that Dyer had used his position for personal financial gain.

The history behind the accusation began in 1859, when Dyer, then a captain, proposed to the Chief of Ordnance that the Department develop projectiles with soft metal expanding caps at the base for use in

67

rifled artillery. Like smoothbore cannons, most early rifled guns were loaded at the muzzle. Ordnance designers were faced with two problems; first, a rifle round had to fit loosely enough in the cannon to permit the loader to ram it down the bore; second, it had to fit tightly enough to trap propelling gas and to engage the spiral grooves when the gun was fired. Dyer sought to solve the dilemma by designing a shell with a base that would expand under the force of explosion.

It was not a novel idea: the Minie bullet worked in much the same way; and Ephraim Whitman, an American, had patented a very similar concept five years earlier; but Dyer seemed to think that the invention was his.

68

However, he never took out a patent on it. Dyer's design soon appeared in shells manufactured by two civilians, Robert Parrott and John Absterdam.

69

70

As the war entered its last years, several civilian inventors sought government contracts for artillery ammunition. One of these was

Clifford Arrick, the designer of the Eureka projectile. The Ordnance Department tested the shells provided by Arrick, Absterdam, and several others. Of six shells tested, the Eureka was listed as first in order of merit, and the "Dyer" Absterdam was last. ⁷¹ Subsequently, however, as Chief of Ordnance, Dyer purchased only 5,000 of the Eureka projectiles while ordering 68,000 of the Absterdam variety. ⁷²

In Howard's congressional hearings, Dyer was accused of collaborating with the "Absterdam party" for financial gain. An attorney for Absterdam interests testified that A. C. Dickson, a contractor for the shell, had promised Dyer monetary compensation based on the size of the contract. ⁷³ Dickson's wife corroborated the testimony. It was damning enough evidence, but the accusations broadened to include the reason for Dyer's appointment as Chief of Ordnance.

It was the committee's conclusion that Dyer had been appointed to the post so that the "Absterdam party" might secure lucrative contracts for artillery ammunition. Referring to the vaguely defined "party," the Senate report states:

Impressing, . . . , the President [Lincoln] and his political friends, . . . their influence was exerted to induce General Ramsey to issue a large order for these projectiles, for service; but he [Ramsey] honestly and, as the result shows, most properly resisted all such influence, . . . the Absterdam party, despairing of their power to have their shell bought by General Ramsey, deliberately went to work to have him removed; . . . they not only succeeded in this, but . . . ; they actually named as his successor Major A. B. Dyer. Mr. Dickson testifies that he had been assured by Major Laidley [Ordnance Department] that if Major Dyer should be made Chief of Ordnance, the 'Absterdam party' would get all the orders they wanted, . . . ⁷⁴

That Lincoln was interested in the shell is indisputable. He ⁷⁵ did encourage a reluctant Ramsey to buy some for evaluation. And in an order to Captain James G. Benton at the Washington Arsenal directing that a test of the shells be conducted, the President referred to

76

A. C. Dickson as "my friend." However, former Secretary of War Stanton testified that he alone decided that Dyer should replace Ramsey and that the President did not initiate, but only approved the decision.

77

The investigation was a vicious affair with political overtones. The charges made in the report were released through the press to the public. The Chief of Ordnance was incensed; and he boldly wrote to Secretary of War John M. Schofield requesting ". . . that I may be brought to trial before a court-martial, at an early day, on each and all of the offences charged against me in the report of the Select Joint Committee on Ordnance, . . ." In response to Dyer's request, a military Court of Inquiry was convened in Washington in November 1868.

78

The investigation of Department activities begun by Senator Howard's committee in 1867 had continued through the session of the Court of Inquiry. The question of Dyer's involvement with the Absterdam interests was treated separately from the other issues that drew the scrutiny of the committee. The report on Dyer was issued in July 1868, and the Court of Inquiry convened in November. In January 1868, prior to the issuance of the July report, Dyer appeared before the committee to answer questions about royalties paid to Rodman.

79

It was a tight-lipped Dyer that took his seat before Howard's group. With replies that were cold and barely more than monosyllables, he responded to needling questions about royalties collected by Rodman. He answered that he knew little about the inventor's patent arrangements. The inquisitor suggested that total royalties already paid amounted to about \$263,660, of which half belonged to Rodman. The Congressman

implied that Rodman, with Dyer's assistance, was becoming a rich man
80
as a result of his association with the Ordnance Department.

At the time of the investigation, Rodman was assigned as
Constructor of Ordnance for the Department, a particularly sensitive
position for the man under the circumstances. Among his duties was
responsibility for determining what kind of metal should be used for
81
gun construction.

The parancia that Dyer must have felt was shared by at least
one of his interrogators. A year earlier, the committee had passed a
resolution calling for a halt to acquisitions of cast-iron heavy artil-
lery. The Secretary of War had subsequently ordered Dyer to buy no more
82
without his authority. Dyer later wrote in his annual report that
"Persistent efforts have been made for some time past by ignorant or
designing persons to destroy public confidence in the heavy guns which
83
have been provided by the ordnance departments of the army and navy."
Dyer had not made the category of "ignorant or designing persons"
sufficiently exclusive; it was too easy for his congressional inquisi-
tors to infer that they might be included. Dyer must have shifted a bit
84
in his seat as he explained that, that had not been his intention.

The anger of the Congressmen was further excited by the testimony
of civilian inventors. Horatio Ames complained to the committee that
the government had rifled some of his cannons with a twist that was too
slow, one that insured that the guns would burst. He added that some of
his pieces were test-fired with excessive propelling charges, which un-
fairly disqualified the guns from purchase, because the government had
rules against taking into service cannons that had been tested under great
85
strain. There was some validity to Ames' charges. Even Major Laidley,

an ordnance test officer, was willing to admit that the rifling and powder were inappropriate. ⁸⁶ However, in defense of the ordnance agencies, it must be said that the guns were of a new construction, and as a result, excessive testing was not necessarily unreasonable. ⁸⁷

Norman Wiard, another civilian, was called to give his opinion on heavy artillery. Like Ames, he had been disappointed in a past attempt at a government contract. Wiard did not limit his criticism to simple facts as he lashed out at the performance of military weapons developers:

. . . ; how much life of citizen soldiers and honor of the nation have been misdirected and wasted, . . . I am, . . . confident that no example of such imbecility of invention and paucity of practical results ever before attended an effort conducted with so much flourish, on so grand and expensive a scale [the development of heavy artillery] , . . . ⁸⁸

The tone of Wiard's condemnation was reflected in the final conclusions of the committee.

In February 1869, having completed its work, the committee issued a report of findings. It was a scathing denunciation of the weapons development agencies of both the Army and the Navy. Committee members were harshly critical of ordnance officers for failing to provide the nation with effective, rifled, large-caliber guns. European designers had done no better, and the Congressmen were willing to admit ⁸⁹ it, but that did not mitigate their anger. They charged the officers of the Department with incompetency:

Mechanics is an exact science, and ignorance . . . in the construction of guns would seem to show either want of knowledge of its principles, failure to understand their application, or superficiality of investigation, surprising in men whose minds have been from boyhood trained in the direction of a specialty. ⁹⁰

Also, they accused them of laziness:

. . . , the ordnance officers, knowing their positions secure to

them for life, have not felt the incentive to exertion and improvement which stimulates men not in government employ, and they have become attached to routine and to the traditions of their corps, jealous of innovation and new ideas, and slow to adopt improvements.⁹¹

And, they called them arrogant:

. . . , these officers, educated to a specialty and proud of their positions, come to look upon themselves as possessing all the knowledge extent upon the subject of ordnance, and regard citizen inventors and mechanics who offer improvements in arms as ignorant and designing persons, and pretentious innovators, who have no claim to consideration.⁹²

But, perhaps the most damning accusation was conflict of interest:

. . . prominent officers have been inventors of arms, and have possessed sufficient influence to secure the adoption and retention in service of their inventions frequently without due regard to the question of real merit. . . .⁹³

It would be no understatement to say that these were strong allegations of general misfeasance. The record of the Ordnance Department was certainly not above suspicion, but by the late 1860's antagonisms between the committee and the Department seemed to maintain their own momentum, the product of emotion as much as reason.

The Congressmen recommended that officers be prohibited patent rights on inventions used by the government.⁹⁴ The political hazards of holding a patent were clear. Although officers continued to produce novel ideas that contributed to the development of American ordnance, it is impossible to determine to what degree the example of the inuendos that attached themselves to Rodman might have discouraged military inventiveness among other soldiers.

Having considered the matter of patents, the committee moved on to attack the very existence of the Ordnance Department. They recommended that it be entirely abolished and that its duties be transferred to the Artillery.⁹⁵ The recommendation rekindled an

argument that had smoldered ever since the establishment of the Ordnance Department.

The committee made other recommendations, but the one of most immediate importance to the Ordnance Department was that work cease entirely on the armament of fortifications. The Congressmen were not opposed to coast defense, but they were very much against Dyer's program of acquisition. They regarded smoothbores as obsolete and money spent on them as wasted. And while they were in favor of rifled guns, they were opposed to Dyer's new plan to satisfy the requirement by rifling Rodman smoothbores. ⁹⁶ The record of cast-iron, rifled artillery was by no means excellent, but it was not clear that any other metal was better. The committee stopped short of recommending that Ames' gun be adopted; it did, however, insist "That every encouragement should be given to inventors [civilian], and a full and fair trial accorded to all devices offered to the government that promise a solution to the ordnance problem." ⁹⁷

The Court of Inquiry, called to investigate the July 1868 charges against Dyer, had been in session during the final months of the committee's investigation. The evidence against the Chief of Ordnance was reheard by four general officers headed by George H. Thomas (of Rock of Chickamauga fame). The court cleared Dyer of all charges of misconduct. On the central issue of the alleged manipulation of contracts for personal gain, the generals determined that Dyer had received no compensation and that any claim by Dyer for royalty rights was no more sinister than the simple ". . . pride of an inventor or a desire to protect the interests of the United States." ⁹⁸ The court did not accept the allegation that Dyer sought financial compensation. The

findings of the court give the faint appearance of a "whitewash;" but on the other hand, Dyer seems to have been somewhat "railroaded" in the previous congressional hearings.

Whatever the truth may be, the case presented by Dyer's detractors was seriously injured by a countercharge made by Major Benét and confirmed by Benjamin Hotchkiss, a notable civilian designer of ordnance. Benét declared that Clifford Arrick, had asked Hotchkiss in 1867 ". . . to join a ring of speculators in projectiles, in order to reconstruct the Ordnance Department for the purpose of putting their own projectiles upon the government. . . ." ⁹⁹ Arrick, one of Dyer's accusers, was the inventor of the Eureka projectile which had been portrayed as unfairly ignored by the Chief of Ordnance in the congressional investigations in 1867. After hearing this and other testimony, the court recommended that no further action be taken against Dyer.

President Grant approved the recommendation of the court in May 1869. ¹⁰⁰

No doubt bolstered by the court's decision, and as if to prove that he could not be intimidated by the weight of congressional criticism against him, in 1869 the irrepressible Dyer continued his emphasis on cast-iron weapons. The engineers of his department successfully increased the propelling charge for the 15-inch smoothbore, giving it greater effectiveness and new importance, according to Dyer. In addition, they were conducting experiments with smoothbore guns of even greater size--two 20-inch mammoths that had been built earlier in the decade. In his continuing work on smoothbores, Dyer was supported by William Sherman, still the Commanding General of the Army. ¹⁰¹ In a letter to Dyer, he wrote, "I have no faith at all in long range firing on land or on the seacoast. Either a 10-inch or 15-inch smoothbore has range and

accuracy enough for practical effect." Sherman's only recommendation
 on rifled artillery was that experiments should continue. ¹⁰²
¹⁰³

Earlier, with the approval of the Secretary of War, Dyer had ordered the construction of seven cast-iron, rifled guns in calibers of 8-, 10-, and 12-inches; and, it was with embarrassment that he had to admit that several had failed in recent experiments. However, the Chief of Ordnance finally appeared to be willing to give the ideas of civilians a fair hearing; he secured permission from the Secretary of War to solicit the construction of one 10-inch and one 12-inch wrought-iron rifle from any manufacturer who would agree to his specifications. His principal requirement was that the inventor would be paid double the cost of a cast-iron gun if his wrought-iron weapon proved to be twice as

durable. ¹⁰⁴ If the Ames' price of one dollar per pound wrought iron was taken as a guide, at a time when cast iron was selling for a little over seven cents, it is easy to see why there was no rush of appli-

cants. ¹⁰⁵ If Dyer was a rascal, he was certainly an unreconstructable one.

His intransigence was met by equal stubbornness from Congress. In 1867, the Army board on coast defense had recommended the acquisition of large-caliber artillery in the following numbers and types: 810 smoothbores, 810 rifles, and 300 mortars. Three years later, not one of the guns had been provided, despite Dyer's repeated annual request for

funds. ¹⁰⁶ Even the Chief of Ordnance's assurance that Rodman's patent had expired could not pull money from the lawmakers for cast-iron
¹⁰⁷ artillery.

The Ordnance Department ended the decade of the 1860's alienated, in general, from the community of civilian ordnance inventors,

estranged from Congress, and firmly committed to the construction of cast-iron heavy artillery; all of these were liabilities. The controversies that boiled around Dyer certainly reduced the efficiency of the Department, although the total effect is impossible to gage. The Department entered the next decade under the full weight of its handicaps from the last one.

CHAPTER V

1870-1874: SCATTERED SEEDS OF TECHNOLOGICAL CHANGE

The first half-decade of the 1870's was a period of stagnation in the development of American field artillery materiel. At the same time, however, it was the seedground of several ideas that would help to determine the direction of future development. The initial receptiveness of the Ordnance Department to some of the ideas was unenthusiastic at best. The ideas would flower at various rates; a few would not reach full bloom for many years. As the agency charged with the development of materiel, the Ordnance Department, with its strengths and weaknesses, was at the center of the evolutionary process.

In 1870, Dr. William E. Woodbridge, of New York, attracted Dyer's attention with a plan to construct a 12-inch rifled gun of bronze and wire. Woodbridge had pioneered the wire construction of cannon barrels in 1850. His plan was to wrap wire upon an iron tube and then strengthen the windings by brazing them with molten brass. In the early 1860's, he had successfully constructed a 2.5-inch gun on his principle, but an attempt at a 10-inch model ended in failure. Nevertheless, Woodbridge's plan was later reviewed by a board of officers, who recommended that it be used for the construction of a 12-inch rifle. The recommendation was approved by the Chief of Ordnance and the Secretary of War in 1870. Dyer then requested that Congress provide \$200,000 for the manufacture and test of the weapon.

His request for money was made necessary by a law passed by

Congress that year, which required that the unexpended balances of appropriations not designated as permanent or indefinite be returned to the government surplus fund. The act removed such money from further Ordnance Department use. Dyer had planned to use unexpended funds for the purchase and test of the Woodbridge weapon.⁴ The congressional move caught him by surprise, and denied him the flexibility that he had previously enjoyed in the use of unexpended money for development projects. To no avail, in October 1871, Dyer repeated his request for funds for the Woodbridge gun.⁵ Meanwhile, there had been a war in Europe.

In July 1870, France had declared war on the German Confederation headed by Prussia. It was a precipitous move by Napoleon III, Emperor of the French. Within two months, his armies were shattered, and he was a prisoner. Although hostilities continued until May 1871, the swiftness of initial German successes captured the imagination of the world.

The Austro-Prussian War in 1866, coming as it did only a year after the end of the American Civil War, went largely unnoticed by the United States Army--an army still resting in the aftermath of its own recent success. By 1870, the tendency of the Army to look inward on itself had dissipated enough to permit some absorption of the lessons of the Franco-Prussian conflict. In general, the artillery lessons of the war served only to reinforce the concept of direct fire.

The Prussians aggressively employed field artillery, not in the far-forward manner of Napoleon, for the rifle prevented that, but up front and in mass to the maximum extent practicable. They placed guns near the head of an infantry column with the intent of bringing massed

fires upon the enemy as soon as contact was made. ⁶ Against infantry in the open, artillery was deadly; but when riflemen fired from behind ⁷ cover they could still drive guns from the field. At the start of the war, there was some question among foreign observers about the effectiveness of the participating field artillery, particularly that of the ⁸ French. However, the conflict had not raged long before the power of ⁹ the Prussian guns became evident.

The effectiveness of the Prussian guns was the greatest tactical surprise of the war. Four years earlier in the war with Austria, the Prussian field artillery had performed poorly. At that time, they used a mixture of both smoothbores and new rifled breechloaders. Also, they employed the Napoleonic tactic of retaining a large portion of artillery in reserve. In the four year interval that preceded the war with France, the Prussians gave great emphasis to the improvement of their artillery. In essence, they did three things: stressed training, equipped themselves completely with rifled breechloaders, and abolished the concept of an artillery reserve. In contrast, when war came in 1870, ¹⁰ the French still used rifled muzzle-loaders and continued to hold many of their guns in reserve for special concentrations. In the test of battle, the Prussian artillery achieved a clear superiority over that of the French.

In hindsight, the advantage of breech-loading artillery seems indisputable; but the matter was not so clear in 1870. An observer for the British press reported from Metz that Prussian gunners often had difficulty working the mechanical breeches. In addition, loaders had to take time to move from behind the pieces to avoid the sharp recoil when the weapons were fired. Muzzle-loading artillery suffered neither

of these defects.

Even the advantage of massing all guns to the front rather than retaining some in reserve did not universally impress soldiers. In the United States, influential artillerymen had been proponents of a reserve before the War of 1870, and their advocacy was little reduced by the results of that conflict. The American artillery historian Lieutenant William Birkhimer reflected the prevailing attitude of his contemporaries in the 1870's when he wrote ". . . it is not admitted that this [the Prussian deployment of all guns] is the only proper method."¹² Birkhimer realized that the Prussians concentrated their guns rapidly to the front to prevent them from being destroyed in detail and to gain an ascendancy of fire; but he saw more of an advantage in the flexibility that accrued to the commander who withheld a portion of his artillery from the battle, with the intention of concentrating it at a decisive place.¹³

The attitude of American artillerymen, as typified by Birkhimer, was, in part, the result of a lingering belief in the Napoleonic decisiveness of cleverly executed tactical maneuver. What they failed to fully perceive was that weapon technology was producing a subtle shift toward the dominance of the great lethality of modern firepower. And the shift was indeed subtle, because the ingredient of maneuver, so difficult for the Army of the Potomac to achieve in the final months of the American Civil War, was clearly alive and well again in 1870.

The Prussians won the war in a few months, in part, by combining aggressive firepower with a combination of strategic offense and tactical defense.¹⁴ By 1870, both the Prussians and the French held the opinion that modern firearms gave the defense a devastating advantage. The Chief of the Prussian General Staff, Helmuth von Moltke, had a plan to

avoid deadlock: it was to bypass defensive positions, if possible.

If an attack was necessary, then it was to be done only after a heavy artillery bombardment. His third option was to seize ground in an attempt to compel the enemy to attack. ¹⁵ In battles up to and including Sedan, it was typical that German columns would move to occupy positions on the flanks or rear of French forces, which would cause the defenders to leave their positions and attack in an attempt to clear the threatened sector. ¹⁶ The tactic gave the invader the advantages of the defense.

17

Trenches were used during the Franco-Prussian War; but the deadlock that they had helped to generate six years earlier in the American conflict failed to reappear. Of course, there were differences between the two wars. In 1864, the mobility restriction of the Wilderness and the defensive resignation of a long exhausted Confederate army combined with the deadly effect of the rifle to add power to the trench. The full equivalents of the first two factors were absent from the fight in 1870. There were other considerations that contributed to the successful mobility of the Prussian Army: the quality of generalship, the advantage of the General Staff, and effective mobilization to name three. But the point is that the trench had greater impact in the earlier conflict in America than it did in the War of 1870. As a result, the challenge that the trench posed to the concept of the direct-fire employment of field artillery was reduced. This inconsistency in the test of war led to a rehabilitation in the reputation of direct-fire field artillery.

Historian J. F. C. Fuller has cited the Franco-Prussian War as an example of the growing power of artillery over infantry. ¹⁸ Without

question, the deadly effect of field guns against men in the open had been demonstrated; but the truth of that matter had never been in doubt. What was absent from the war was the full effect of the neutralizing power of the trench--a power so aptly demonstrated in the earlier conflict in America.

It was not long after the War of 1870 that experiments in both Bavaria and Switzerland, reported in America, tended to refute any perception that the relative power of field artillery was on the rise. At a range of 800 yards, rifle fire was judged to be three times as deadly as that of artillery. However, these were test situations; and the riflemen were said to be marksmen. As a consequence, a correlation of the results to the reality of the battlefield was difficult. ¹⁹ Between the uncontrolled tests of battles and the controlled, but perhaps unrealistic, experiments of war games, the truth of the efficiency of field artillery was clouded.

In any event, the adoption of breech-loading rifles was making even shallow shelter trenches practical. Infantrymen could load the new weapons from the prone position. Within four years after the War of 1870, the U.S. Army began to issue, for the first time, entrenching tools to individual soldiers. The action was combined with the test of a system of rapid field entrenchment more extensive than any the Army had yet employed. ²⁰ In Europe, the Austrians would not allow even the frozen ground of winter to deny them the cover of field fortifications; it was reported in the United States that they had successfully tested ²¹ the protection of snow parapets against both rifle and artillery fire. Although field fortifications had not been a significant factor in the War of 1870, concepts of their employment were growing.

If the Franco-Prussian War had any effect on American ordnance development, it was to reinforce satisfaction with the status quo. Not surprisingly, the most immediate effect of the war was the precipitation of another integrity controversy within the Ordnance Department. In February, Senator Charles Sumner introduced a resolution in the upper house calling for an investigation of the sales of ordnance stores made by the government during the war. The resolution was accompanied by an allegation of collusion between American officials and arms purchasing agents of the French government, with a subsequent lack of accountability for up to \$1,700,000.²² Both the Senate and House initiated²³ investigations into the matter.

The end of the Civil War left the United States with a great surplus of war materiel. It was government policy to dispose of unneeded ordnance stores in either public or private sales. The Ordnance²⁴ Department handled the sales. After the initial disasters suffered by the French in 1870, they began to purchase great numbers of surplus weapons from the United States. Since it was contrary to the status of a neutral to provide arms to a foreign belligerent, the French did their²⁵ purchasing through various private contractors. Sumner alleged that ordnance officers dealt with the contractors knowing that they were²⁶ acting as agents for the French government.

Evidence on the extent of such knowledge among ordnance officers is contradictory. On 13 October 1870, Dyer came into the possession of a telegram that indicated that W. C. Squire, an arms purchaser, was buying weapons for transfer to France. Dyer immediately informed the Secretary of War, William Belknap, that Squire was an agent for the French.²⁷ Belknap then ordered the sales to cease. Although Dyer exposed Squire

as an agent of France, the Ordnance Department seemed to permit sales to other contractors. Significant quantities of weapons continued to move through the port of New York. The ordnance officer in charge of the sales was Major Silas Crispin. There was no evidence presented to the investigating committees to indicate that Crispin knew where the weapons were bound; however, employees of the Ordnance Department delivered the materiel to piers for shipment; much of it was loaded on French ships; and it was common knowledge at the docks that the vessels were returning to France. ²⁸ A minority on the House committee concluded that ordnance officers must have known the destination of the vast number of weapons sold during the final months of the Franco-Prussian War; ²⁹ but the majority concluded that the Department had exercised ³⁰ diligent care to make no sales to either belligerent.

The Senate Select Committee under Hannibal Hamlin went a step further; in a reinterpretation of the status of a neutral, it declared that sales directly to Louis Napoleon himself would have been proper. And in a surprise move it criticized two of its own members for precipitating the controversy. The committee concluded that the entire episode had been the result of an attempted manipulation by a member of the French legation, the Marquis de Chamburn, to aid a relative, Monsieur Pace, on trial in France for the misappropriation of government funds. Pace had been a French consul in New York, and he was apparently involved in weapons purchasing. The Marquis de Chamburn first approached Senator Patterson and then Secretary Belknap with an allegation that the lost funds had been misappropriated within the War Department. When the Frenchman failed to spark an investigation, he turned to Senators Carl Schurz and William Sumner. Acting upon the allegation, Sumner introduced

the resolution that precipitated the congressional inquiries. At the conclusion of the investigation in May, the Select Committee included in its report:

Had Senators Sumner and Schurz applied to the Treasury and War Departments for information upon this subject, which they could have done, with the slight inconvenience of five minutes walk, but which they omitted to do, they would have learned all of the material facts which it has cost the Government thousands of dollars to ascertain by this investigation. They would have learned that there was no discrepancy between the accounts of the two Departments, and that there was no fraud nor violation of the law of nations in the sales.³²

The truth of the matter, like the earlier controversy over the Eureka shell and Dyer's appointment as Chief of Ordnance, was clouded by the opaque reality of politics. Sumner and Schurz were two Republican Radicals who had broken with Grant early in his administration. In fact, Sumner was forced from his chairmanship of the Senate Foreign Relations Committee in March 1871 as a result of differences with Grant.³³ The political cleavage was clear, when in its report, the Select Committee referred to Patterson and Belknap as "friends of the Administration," in obvious contrast to Sumner and Schurz.³⁴ Incidentally, the earlier nemesis of the Ordnance Department, Jacob Howard, was no longer in the legislature.³⁵ Whether by merit or the vicissitudes of politics, Dyer and his department emerged from the investigations in the spring of 1872 in somewhat better shape than from previous skirmishes with Congress.³⁶

Dyer's health, however, was failing. He testified before the Senate Committee, but when he was called to appear before the lawmakers of the House, his doctors replied, ". . . his health is so precarious, and he is in such a critical condition, that an examination now would endanger his life."³⁷ In deference to his health, the House committee

38

excused him. With similar consideration, his superior, Belknap, occasionally went to see him, rather than giving him the trouble of climbing the stairs to the Secretary's office. ³⁹ The poor health of its chief and the distractions of the recent investigations hardly enhanced the efficiency of the Ordnance Department.

By mid-1872, Dyer's request for experimental funds for the Woodbridge guns had remained unanswered for nearly two years. In June, the lawmakers finally took action; but it was not the kind of answer that Dyer had originally sought. They appropriated \$270,000; however, they laid down their rules for the tests. The Department was required to evaluate at least three different models of heavy ordnance as selected by a board of officers appointed by the Secretary of War. An additional requirement of significant importance was that the weapons evaluated ⁴⁰ had to contain breech-loading as well as muzzle-loading models.

Breech-loading was a relatively new and untried concept in heavy artillery. Although the idea of loading a cannon from the rear was quite old, it was not until the 1850's that the system was effectively adopted to even light artillery. The English Armstrong and Whitworth field guns were breechloaders, as were the Krupp weapons used by the Prussian field artillery in 1870. In spite of these early applications, there was no universal agreement on the value of the system over muzzle-loading.

The principal difficulty with breech-loading artillery was the escape of propellant gas around the breech mechanism. High ignition pressures were trapped by the solid butt of a muzzle-loader, but they tended to force their way past the movable parts of a mechanical breech. This would cause a fouling of the breech mechanism and a loss of

propellant force. The difficulty increased significantly with the high propellant pressures generated in large, rifled artillery. In fact, the difficulties were such that ordnance producers in Great Britain, who had pioneered breech-loading design, virtually gave up the effort and returned to the production of muzzle-loaders.⁴¹ However, the trend in artillery was toward larger and heavier guns; and as barrels lengthened and pieces became more difficult to maneuver, muzzle-loading became increasingly less efficient.

It was relatively easy to load a field piece from the muzzle; therefore, there was no real need to wrestle with the difficulty of breech improvement in light guns. As a result, in America, the needs of heavy artillery tended to drive what search there was for an effective breech design. However, it is noteworthy that it was not a military officer, but Congress that initiated the search.

In response to the requirements accompanying the 1872 appropriation, the Secretary of War appointed a board of officers to examine the plans and models of heavy ordnance offered by hopeful designers. The Board on Heavy Cannon consisted of seven officers: four from the Ordnance Corps, two from the Artillery, and one from the Corps of Engineers. Colonel Robert H. K. Whiteley of the Ordnance Department headed the board. Among the other ordnance members were Lieutenant Colonel Theodore Laidley and Major Silas Crispin.⁴² (Like Dyer, Laidley and Crispin had been the subjects of innuendos of improprieties in previous congressional investigations.)

The board convened in New York City on 10 July 1872 and completed its work by the end of August. During the session, it reviewed forty proposals and chose nine for test by the Ordnance Department.⁴³ The

nine weapons selected are shown in table 3. The variety of breech designs submitted by enterprising inventors is interesting. Two of the designs are shown in figure 8. It is worth noting that the idea of converting Rodman smoothbores to rifles by lining them with tubes of wrought iron or steel was given to the Ordnance Department by Major Crispin, a member of the evaluating board.

With the report of the board of officers in hand, Dyer predicted that the procurement and trial of the guns would probably consume all of the year 1873.⁴⁴ It was a very optimistic prediction. In reality, the report initiated an effort that would drag on for a decade. Although the affair was lengthy, it was of some benefit: it not only sparked interest in breech-loading, it briefly initiated the first serious American consideration of guns made of steel.

One of the weapons selected for test was a steel, rifled breech-loader produced by the German ordnance manufacturer Friedrich Krupp. Three years earlier, Krupp had offered to provide the United States with an 11-inch gun for evaluation. At that time, Dyer consulted with the Commanding General of the Army, Sherman, who stated that he liked the gun but that he was opposed to purchasing foreign weapons except as a model or experiment.⁴⁵ When Congress finally provided developmental funds in 1872, Dyer solicited a price from a Krupp agent. When he was told that the cost of 12-inch gun with carriage would be \$48,500, Dyer dropped the idea of purchasing the German weapon. He concluded that, "An armament composed entirely of such guns would, it is believed, cost more than the most expensive fort of modern construction."⁴⁶ Not only was the cost of a single gun high, but Krupp stipulated that should his gun successfully pass the evaluation, the United States would be

TABLE 3
WEAPONS SELECTED FOR TEST BY THE
BOARD ON HEAVY CANNON, 1872

Muzzle-loaders

W. E. Woodbridge's 10-inch rifle

Alonso Hitchcock's 9-inch rifle

Ordnance Department cast-iron guns (Rodman) lined with wrought-iron or steel tubes, 10-inch smoothbores converted to 8 or 8 1/2-inch rifles

Breech-loaders

Friedrich Krupp's system

E. A. Sutcliffe's 9-inch rifle

Nathan Tompson's 12-inch rifle

French and Swedish systems

Miscellaneous*

H. F. Mann's 8-inch rifle (breech-loader)

A. S. Lyman's multicharge, 6-inch rifle (breech-loader)

SOURCE: U.S., Congress, House, Report of the Secretary of War, Ex. Doc. No. 1, 42d Cong., 3d sess., 1872, pt. 2, 1:340; U.S., War Department, Ordnance Department, Gun Making in the United States, by Rogers Birnie (Washington, D.C.: Government Printing Office, 1907), pp. 20, 21, 29; and U.S., Congress, House, Report of the Secretary of War, vol. 3, Ex. Doc. No. 1, 44th Cong., 2d sess., 1876, pt. 2, p. 55.

NOTE: *It is not clear from the record why the guns designed by Mann and Lyman were listed as miscellaneous.

FIGURE 8

TWO BREECH DESIGNS SUBMITTED TO THE
BOARD ON HEAVY CANNON, 1872

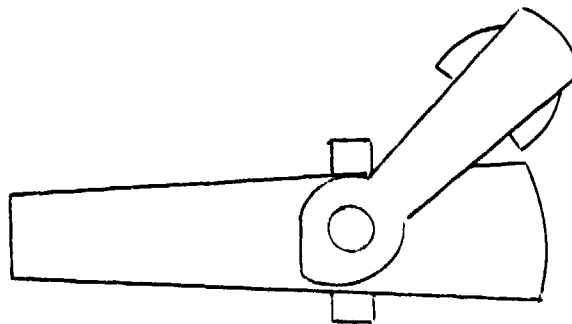

Design of John B. Moody

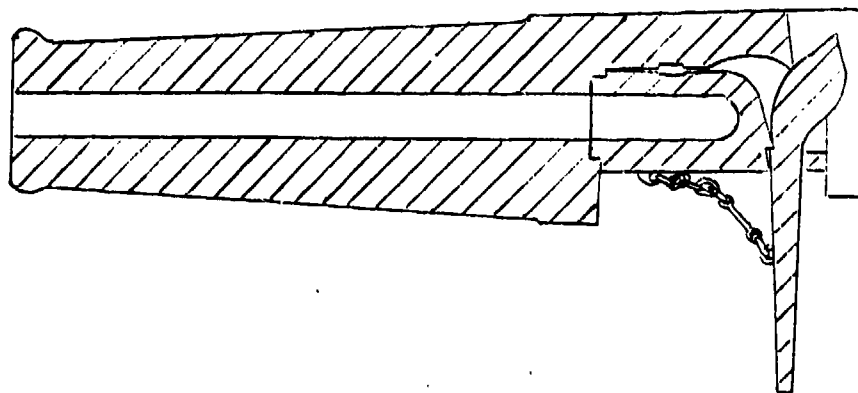

Design of L. M. Lull and J. T. Starr

SOURCE: U.S., Congress, House, Report of the Secretary of War, Ex. Doc. No. 1, 42d Cong., 3d sess., 1872, pt. 2, pp. 427, 431.

contractually bound to purchase several more. Congress balked at this demand, and as a result, the proposed test of the Krupp weapon was abandoned.⁴⁸ Although it came to nothing, the initial consideration of the Krupp weapon was the first serious interest shown by the United States in steel artillery.

Wrought iron has a low carbon content; cast iron has a high one; somewhere between the two lies steel. There are many types of steel with widely varying percentages of carbon. Wrought iron is made by heating iron ore to a pasty mass in a charcoal fire. In the process, some carbon is absorbed by the metal. The ancients were limited to the production of wrought iron simply because they did not have furnaces hot enough to convert iron ore into a fluid state.⁴⁹ Eventually, methods were devised to provide the necessary heat so that ore could be melted and then cast into desired shapes. This reduced the expense and increased the versatility of iron. However, in the melting process iron absorbs large amounts of carbon, which makes the cooled metal brittle. Cast iron, although it is inexpensive, is not an ideal metal for large gun construction because of its low elasticity. Essentially, steel is molten iron that has been partially decarbonized. The result is a castable, elastic metal.

In 1740, Benjamin Huntsman, an Englishman, had devised a method of producing crucible steel; however, it was a very expensive process. Subsequently, an American, William Kelly, discovered that molten iron could be decarbonized simply by blowing air through it. In 1855, Henry Bessemer, another Englishman, used Kelly's idea to construct an ore converter, which somewhat reduced the cost of steel production.⁵⁰

Even after the advent of Bessemer's process there was no

universal rush by gunmakers to employ steel in artillery construction. 51
For many years, the Krupp works in Germany had produced guns from steel;
and the English Whitworth field pieces were made of the material; but,
in general, ordnance designers continued to use older metals. Steel
was still more expensive than cast iron; and Bessemer steel, the least
expensive variety, had developed the reputation of changing molecularly
52 into an unsafe, fragile form. The science of steel production was
53 still relatively new, and much was yet to be learned about the metal.
In any event, in the early 1870's there was no facility in the United
States capable of producing steel of the quality needed for gun construc-
54 tion.

The prevailing requirements of field artillery design were incapable of producing interest in steel. Both wrought and cast iron were fully able to contain the propulsive pressures of light, rifled guns. A desire for longer range or greater caliber in light pieces might have created a need for a better metal, but neither the Artillery nor the Ordnance Department displayed any interest in such advances. The reason for inactivity in this area is simply that the guns on hand were thought to be well adapted to the support of the maneuver elements of the Army. In contrast, the escalating race between artillery and naval armor continued to generate a need for guns of greater power. As a result, the eventual American search for better cannon metal was the product of seacoast gun requirements.

Another advance that was driven by the requirements of heavy artillery was recoil control through the use of fluid compression. The idea appeared in 1867 when a board of Army Engineers reviewed a proposal submitted by James Ryan, a civilian inventor. Ryan had conceived of

using floating seacoast batteries on land. His concept was to create a pond, upon which would float an armored turret containing several heavy guns. The principal value, as he saw it, was the ease with which the floating turret would be rotated. His concept was quickly dismissed as impractical by the board. However, he had included a secondary design feature: machinery for using compressed air to control the recoil of a gun. The board perceived that there might be some value to this subsidiary plan;⁵⁵ but the idea lay dormant for a while.

Formerly, the recoil of heavy guns on ships and in fortifications had been controlled by a variety of mechanical devices ranging from simple ropes to mechanically complex counterpoised carriages.⁵⁶ As guns grew in size and power, the problem of efficient recoil control became more difficult.

In 1871, Dyer noted that the old iron carriages of the 10- and 15-inch smoothbores could no longer adequately contain the recoil generated by the large propelling charges then in use with the weapons.⁵⁷ The next year the Department began to experiment with pneumatic buffers. Dyer quickly became an advocate of the devices:

. . . , the buffers perform their work so freely and smoothly as to solve the very difficult problem of platform constructions, which under the old methods of checking the recoil were often shattered by the shock and strain. . . .⁵⁸

A board of five officers headed by Lieutenant Colonel William H. French of the Second Artillery convened in New York City in January 1873 to review and report upon a variety of proposals on heavy artillery carriage design.⁵⁹ The Board on Gun Carriages was packed with talent. For instance, Colonel French had collaborated with William Barry and Henry Hunt during the Civil War in the authorship of a popular manual of artillery tactics. Also, the board contained Major John C. Tidball,

the future author of an important work on heavy artillery tactics. And the ordnance representative was Captain Daniel W. Flagler, an officer who would become chief of his branch in 1891.

Dyer was particularly quick to point out in his annual report that every facility was given to inventors who wished to submit their proposals and that a wide range of designs were examined.⁶⁰ Perhaps Dyer was trying to smooth his relations with Congress. The lack of appropriations had certainly brought a halt to his efforts to provide the Artillery with cast-iron heavy weapons.

In any event, the Board on Gun Carriages reviewed fifty-eight proposals from both military and civilian inventors. In the end, it recommended for trial the six inventions shown in table 4. Dyer narrowed the selections even further. He recommended that the Ordnance Department design, figure 9, be adopted for service and that Major Benton's apparatus be tested. The other designs would be ". . . experimented with whenever funds are available for the purpose."⁶¹ Belknap⁶² approved Dyer's recommendation. Whether by merit or design, the familiar pattern of Ordnance Department preference for its own work repeated itself.

There is an interesting observation to be made about the submission of designs for the board's evaluation. Out of forty-five proposals of military origin, only one came from an artillery officer. In contrast, ordnance officers submitted thirteen designs, and members of the Corps of Engineers offered twelve.⁶³ It was evidence that the participation of artillery officers in ordnance design was minimal, even in open competition. It is not enough to say that artillery talent might not have participated because of the predilection of the Ordnance

FIGURE 9

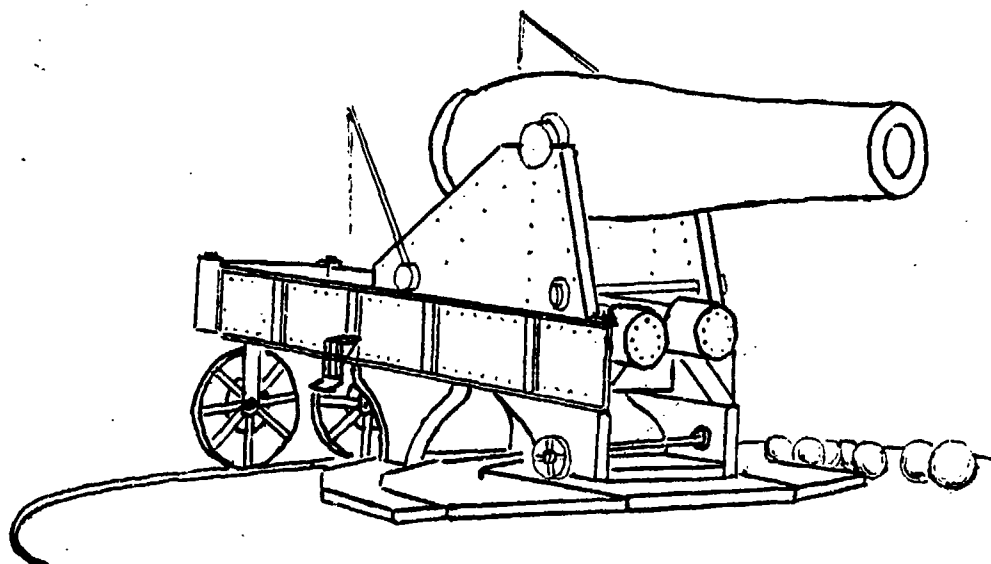
15-INCH BARBETTE CARRIAGE WITH
TWO AIR CYLINDERS

SOURCE: U.S., Congress, House, Report of the Secretary of War, Ex. Doc. No. 1, 43d Cong., 1st sess., 1873, pt. 2, 3:459.

NOTE: The cylinders can be seen on the front of the weapon. They were connected to both the upper and lower carriages. When the gun fired, the recoil drove the upper carriage backward activating the pistons in the air cylinders. The back end of the lower carriage was higher than the front so that gravity could be used to return the gun to battery.

Department for its own designs; the heavy participation by engineer officers would refute any such assertion.

TABLE 4
DESIGNS RECOMMENDED FOR TEST BY THE
1873 BOARD ON GUN-CARRIAGES

<u>Proposed</u>	<u>Inventor</u>
Apparatus for maneuvering heavy guns	Major J. G. Benton, Ordnance
15-inch barbette carriage with two air-cylinders	Ordnance Department
Counterpoise gun-carriage	Captain A. R. Buffington, Ordnance
Device for checking recoil of heavy gun	Captain J. Wall Wilson, U.S. Revenue Marine
Counterpoise muzzle-pivoting gun-sling	Captain W. R. King, Engineers
Depressing carriage	Captain W. R. King, Engineers

SOURCE: U.S., Congress, House, Report of the Secretary of War, Ex. Doc. No. 1, 43d Cong., 1st sess., 1873, pt. 2, pp. 457-458.

In any event, the concept of using a compressed fluid to control recoil, an idea to which the Ordnance Department was now firmly committed, was critical to the achievement of the high rates of accurate fire that would characterize artillery by the turn of the century. Field artillery would benefit immensely from this technological advance that was initially driven by desire to improve coast guns. In fact, the effective control of recoil was vital to the eventual emergence of the concept of indirect fire. However, this is a look ahead, and it would still be many years before compressed fluid would be used to control recoil in field guns.

In contrast to the enthusiasm shown by Dyer for advance in carriage construction, Ordnance Department efforts with new designs in rifled artillery languished. By late 1873, none of the weapons that had been recommended more than a year earlier by the Heavy Gun Board were ready for tests. Dyer attributed the delays to the necessity of overcoming the novel construction requirements of the new designs.⁶⁴

It would not be unreasonable to question the sincerity of Dyer's commitment to change in heavy artillery design. He held that since ". . . no rifle of large caliber has yet been adopted for our service, our present wants can be best met by providing . . . smoothbores . . ." Of course the smoothbores were of cast-iron construction, a metal to which Dyer was still deeply committed. And seeking the forbidden again, he asked Congress for \$75,000 to build two experimental 12-inch cast-iron rifles.⁶⁵ These weapons were separate from the models recommended by the 1872 board; they were to be rifled without the use of wrought-iron or steel inserts. They were a resurrection of a design by Rodman that had been considered but not recommended by the board.⁶⁶ Dyer's stated reason for sponsoring the construction and test of the 12-inch weapons was that recent advances in pressure control in powder promised to make cast iron by itself practical for heavy rifle construction.⁶⁷ To give force to his requests he stated in his annual report of 1873:⁶⁸

. . . should war with any naval power find our harbors open to the attack of iron-clads and their heavy guns, without proper provision having been made for a successful defense, the responsibility will not rest on this Bureau, . . .⁶⁹

In fairness to Dyer it must be noted that diplomatic tensions heightened, and war threatened, in the early years of the decade. The first crisis was over claims against Great Britain for constructing and

assisting Confederate naval raiders. The "Alabama claims," as they were called, had stirred emotions on both sides of the Atlantic. In May 1872, the situation was acute, and war with Great Britain seemed to be a possibility. ⁷⁰ The crisis soon passed, but the Alabama issue had not been cooled for long when support by Americans for the smoldering revolt in Cuba threatened war once again. The gun-running ship Virginus was seized by Spanish authorities, and fifty-three members of the crew, including Americans, were executed. In November 1873, Grant's cabinet met and ordered war preparations, to include the movement of ships and troops to the Florida and Gulf coasts. ⁷¹ In the end, this second crisis, like the first one, passed peacefully.

The Virginus issue was still cooling when Sherman analyzed the needs of national defense for the House Committee on Military Affairs. About coast artillerymen he said, ". . . you have no more valuable servants under the Government" ⁷² He added, ". . . that body of men, . . . , will be very useful to you, in case you suddenly find yourself involved in a war with Spain or Great Britain." ⁷³ Sherman said about relative threats:

The building of railroads, whereby five, ten, or fifteen thousand men may be picked up and thrown from one point to another with great rapidity, and with absolute certainty, takes away from the country all fear of invasion by any nation on earth. We do not fear, now, the landing, on our coast, of the armies of any people. The only object of fortifications on the sea-board is, therefore, to protect some rich city like New York or Boston, which is very tempting to an enemy like England that might dash in, lay the city under contribution, and get out before we could wake up. ⁷⁴

The threat of seaport ransom seems slightly overblown even in a nineteenth-century context. But Sherman was the senior officer in the Army, and his opinion certainly warranted respect.

Taken in the light of the difficulties with Britain and Spain,

and considering Sherman's threat analysis, Dyer's concern with coast defense seems reasonable. However, the particular response planned by Dyer is open to criticism. He wanted to construct great numbers of cast iron, smoothbore, muzzle-loading weapons at a time when other metals, rifling, and breech-loading were growing in importance. Even Sherman urged caution in a proliferation of coast defenses. He felt that it was better to site guns centrally for movement to threatened points, as the situation might demand.⁷⁵ In any event, Congress was not inclined to pay for the great number of old model weapons desired by Dyer.

Although the artillery acquisition effort of the Ordnance Department was oriented on the needs of coast defense, in 1873, for the first time since the Civil War, a small step was taken toward the improvement of field artillery. In its appropriations for 1873, Congress provided \$8,000 for the construction and test of a Moffatt breech-loading field piece, figure 10. The money was contained in the same bill that reserved the \$250,000 for the construction and test of heavy ordnance.⁷⁶ Although the contrast between the two sums is stark, it was a beginning. The gun was a 3.07-inch, steel rifle manufactured by the South Boston Iron Company.⁷⁷ Dyer proposed to take the Moffatt gun and test it against service muzzle-loaders and a breech-loading field piece that had been given to the War Department by the government of Germany.⁷⁸ However, haste was not a characteristic of the Ordnance Department, and tests of field artillery, like the evaluation of rifled heavy guns, would drag on through the decade.

It is not clear whether the steel for the Moffatt gun was cast in America or Europe; but it was probably the latter. A later Ordnance Department order for the metal was filled in England. American industry

FIGURE 10
MOFFATT BREECH-LOADING FIELD PIECE

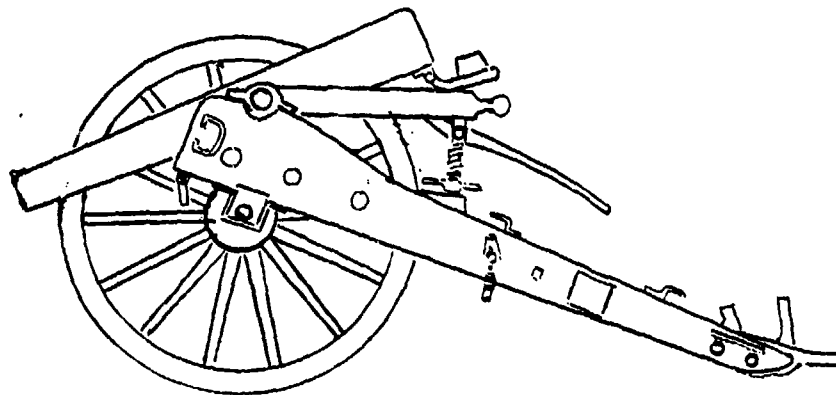

SOURCE: U.S., Congress, House, Report of the Secretary of War, Ex. Doc. No. 1, 44th Cong., 2d sess., 1876, pt. 2, 3:app. h, plate II.

NOTE: The weapon is shown in the open breech configuration.

was producing steel, but it was not of the quality needed for cannon construction. In fact, it was not until 1883, that the quality of American steel gunmetal production began to equal Europe's.⁷⁹

As the Ordnance Department took its first hesitant step toward the improvement of light guns, several disparate events had occurred in Europe which would eventually be important to the evolution of field artillery. In France, the government was considering the adoption of a metallic cartridge case for its new bronze, breech-loading, 3-inch howitzer.⁸⁰ In Austria, the government had solicited designs for shielded Gatling guns.⁸¹ It was the first attempt to enhance the direct fire capability of field artillery by providing armor protection for gunners. And in England, the fancy of sportsmen had been caught by smokeless powder. Earlier, in 1868, a Prussian captain by the name of Schultze had invented a "wood-powder" that gave off little smoke. The German manufacturing plant burned; but a group of English gentlemen soon constructed their own facility to produce the powder.⁸² Thus the desire of bird-shooters to be done with the clouds of smoke that attended their recreational firing helped to maintain interest in a revolution in powder design, although, for America, the revolution would be particularly slow. These widely separated European events were but the beginnings of ideas; their importance would grow with time.

Through 1872 and into 1873, the House Committee on Military Affairs conducted a study on the possible reorganization of the Army Staff. The Congressmen reviewed several issues; two in particular impinged upon the future role of the Ordnance Department as an agency of weapons development: the potential consolidation of the Department with the Artillery, and the possible subordination of staff agencies to the

Commanding General of the Army. In conducting its study, the committee digested the opinions of many officers, both active duty and retired,⁸³ several of whom were among the highest ranking soldiers in the Army.

On the first issue, the potential consolidation of the Ordnance Department with the Artillery, the split in opinion among soldiers is interesting. Of thirty-one officers questioned, only nine thought that the two branches should be combined. And out of seven artillery officers, only four were in favor of the proposed merger.⁸⁴ Among artillerymen, Henry Hunt and William Barry, certainly the two most active proponents of their branch, both pushed for a merger. They were joined in their opinion by Emory Upton. William French was the most notable gunner among the three dissenters.⁸⁵ The split in opinion is evidence that the need for increased participation in weapons development was not universally felt among artillerymen. The committee questioned only two ordnance officers. The sample is too small to draw any conclusions about branch solidarity on the question of merger; but for what it is worth, both ordnance officers were against the idea. One of the officers was Major Stephen Benét, who would soon become Chief of Ordnance, although he had no way of knowing it at the time.⁸⁶ He argued strongly against any merger with the Artillery.

In the early 1870's, an anonymous officer, a highly literate fellow, published a pamphlet in which he recounted the condition of the Artillery, as he saw it. The tract is revealing because it explains some of the lassitude apparent in the arm with respect to weapons development. The anonymous author was quick to criticize what he saw as a paucity of scientific experience among artillerymen. He asserted that "The standard of admittance into the artillery is so low that there

is scarcely any point at which we may begin . . . to educate some officers, . . . " ⁸⁷ (It is understandable that he sought to remain anonymous.) The Artillery School, for which he had praise, had to devote valuable time to the teaching of basic subjects like geometry. And the supplementary instruction of artillery officers given at post schools he characterized as trifling and unimportant. It was a general condemnation of the Artillery for what he perceived as its lack of achievement in the scientific aspects of gunnery. ⁸⁸

As part of a solution to the problem, he recommended the appointment of a Chief of Artillery. It was not a novel recommendation; the idea had surfaced earlier, but there was resistance to it even within the Artillery. "It had sometimes been frowned upon by officers of high rank in our arm Charges of 'axes to grind' have been freely bandied about, and little credit given for motives which would lead officers to regard the general good of the artillery rather than self-interest." ⁸⁹ As part of the anticipated "general good," the outspoken gunner asserted that the proposed office of Chief of Artillery would provide a means ". . . to direct and encourage investigation and experiment; to establish a general and uniform system of instruction; to urge in our behalf needful legislation and regulations; to give us coherency and strength." ⁹⁰ This critic's voice was just one of several that had futilely cried out for a single directing head for the Artillery.

His concern for effective investigation and experiment is of particular interest. He was troubled about what he perceived as a general lack of technical progress within the Artillery. As one example, he cited the lack of interest in curved fire. He felt that curved fire was of critical importance to coast defense because the armored flanks

of modern iron-clad vessels were more or less impregnable to engagement by low-trajectory weapons. In his emphasis on curved fire, he was following the lead of a forward thinking engineer officer, Henry L. Abbot, who had recently published an article on harbor defense in which he accentuated the use of vertical fire to crush the relatively lightly armored decks of ships. ⁹¹ The anonymous artilleryman found his contemporaries to be sadly deficient in the knowledge of mortars:

Officers ordered to the Artillery School generally see the 13-inch mortar for the first time, and regard it as a great curiosity [In addition,] We are without a single correct or useful table of ranges for the 13-inch mortar, nor is it practicable to construct one [a table] until a carefully conducted and thoroughly systematized course of experimental firing shall be had, . . . ⁹²

The critical gunner asserted that Europeans were more advanced than Americans in the area of vertical fire; although, "It is not claimed ⁹³ that other nations have arrived at entirely satisfactory results." For example, in an entire day's practice at Shoeburyness, England against a row of casements, not one shell out of a hundred fired struck ⁹⁴ the target. However, some European nations were beginning to adopt ⁹⁵ rifled mortars which promised greater precision in vertical fire. In fact, as early as 1864, the French had begun to replace smoothbore, seacoast, 32-centimeter mortars with rifled, 22-centimeter howitzers. Although the rifled pieces were more accurate than the smoothbores, their mean error in range was still long--59.9 meters at medium charge, ⁹⁶ at 40 degrees elevation.

The anonymous gunner underscored what he perceived as a general lack of technical progress within the American Artillery; but there was only so much that the members of his branch could do to correct the problem, even if all of them agreed with his conclusions. They could correct range tables; but there was little that they could do to improve

ordnance. Responsibility for weapons design lay with the Ordnance Department. Although artillerymen were the users of cannons, they had little to say about weapons development. It was a dichotomy in which technicians designed guns for the use of tacticians with only the barest of communication between the two groups.

It was an unfortunate situation, but a merger between the Ordnance Department and the Artillery was not necessarily the best solution. From the standpoint of numbers, a merger was not in the best interest of the Ordnance Department; and from the standpoint of weapons acquisition in general, it was probably not in the best interest of the Army. The Ordnance Department contained 63 officers while the Artillery had 280. In the plan of consolidation that Hunt offered the congressional committee, which was essentially a repeat of the merger of the 1820's, twenty field grade Ordnance officers would become an artillery "special staff," while the remainder of the Department would be absorbed into the line regiments. Hunt's plan contained more enthusiasm than logic; and it looked somewhat like "empire building," an observation that must not have escaped Secretary of War Belknap when he said, "Why the ordnance corps should be consolidated with the artillery any more than with the cavalry or infantry, I am at a loss to understand."

Yet to leave the status of the Ordnance Department unchanged would have meant a continuation of its isolation from the Army of the line.

Sherman and others, to include the second ordnance witness before the committee, Lieutenant Colonel Charles P. Kingsbury (retired), recommended that officers be required to serve a number of years in the line before joining the Department. This was the solution adopted by Congress in the Act of 23 June 1874. The grade of second lieutenant

of ordnance was abolished; and all vacancies in the rank of first lieutenant were to be filled by transfer from the line, after an examination by a board of ordnance officers. ¹⁰¹ The congressional action laid to rest the question of consolidation between the Ordnance Department and the Artillery. From the standpoint of artillery participation in weapons design it was not the best solution; however, it was one that realistically recognized the responsibilities of the Department to the rest of the Army.

The solution was less than perfect in other ways. In a field like ordnance development, technical proficiency was greatly dependent upon the accumulation of years of experience. The assignment of young line officers to ordnance duty provided an influx of experience from beyond the confines of the Department, while, at the same, insuring that sufficient years remained in their careers to permit an accumulation of technical expertise. However, the difficulty with the program was that the influx of non-Departmental experience was at the lowest commissioned level; and it is a bureaucratic truism that advice tends to flow down rather than up. Also, as young officers matured within the branch, the tendency, quite naturally, was to become fully committed to the Department view. Nevertheless, the absorption of talent from the line, albeit young, was an improvement over the previous isolation of the Department.

The second question of importance to the Department that was considered by the committee was the relationship of the staff agencies to the Commanding General of the Army. As a staff agency, the Ordnance Department was subordinate to the Secretary of War. Its relationship to the Commanding General was one of cooperation but nothing more. As

Sherman said:

In my office I have no authority, control [,] or influence over anything but the cavalry, artillery, and infantry, and such staff officers [from staff agencies] as are assigned by their respective chiefs, approved by the Secretary of War, and attached to these various military bodies for actual service.¹⁰²

Had the staff agencies been subordinate to the Commanding General, the freedom from military direction enjoyed by the Chief of Ordnance in weapons development would not have existed.

Discontent in the Army with the lack of the Commanding General's authority over the staff agencies was relatively high. Of twenty-four officers who gave the committee their opinions on the matter, only five¹⁰³ felt that there should not be a reorganization. Secretary Belknap, who had direct control of the agencies, was, of course, opposed to any change. It is interesting that Sherman, who had tried unsuccessfully in 1869 to secure complete authority over the staff departments, had somewhat mellowed in his opinion. He recommended that the bureaus in Washington remain under the Secretary of War but that staff agency personnel and facilities outside of the capital come under the authority¹⁰⁴ of the Commanding General. The committee decided to leave the issue alone. The direct authority of the Secretary of War over the Ordnance Department continued.

One thing that emerged from the committee's study was the deep resentment in the army of the line over what was seen to be a privileged life among officers of the Ordnance Department. Sherman was representative of the discontent when he said that,

. . . it does seem a little hard when troops, having been away in a difficult service, exposed to hardships and discomfort, and coming to an arsenal, find that they cannot enter it without permission of a junior officer in charge. It tends to create discontent when they find a captain or lieutenant living in a fine mansion with all the comforts and elegance of a gentleman, while the colonel or

major in command of the troops in the same Army must sleep out under the fence, If a regiment of troops is quartered in the vicinity of an arsenal the colonel will take a shanty or quarters in rough barracks, while the captain or lieutenant of ordnance lives in an elegant mansion, with gardens and hot-houses all around him.¹⁰⁵

Was it perceived relative deprivation or genuine concern over military efficiency that prompted the mood in the Army that demanded military control over the staff agencies? It was probably a combination of both. In any event, the Ordnance Department had successfully survived all of the challenges to its status that were raised during the committee's hearings.

Dyer's health had declined steadily through 1873, and in May¹⁰⁶ of the following year he passed away. It would be an exaggeration to say that it marked the end of an era for the Ordnance Department; some of the controversy that surrounded Dyer passed with him; but the pattern of operation of the Department changed little.

At the time of Dyer's passing, nearly a decade had lapsed since the end of the Civil War. During that time, there had been little significant change in field artillery materiel. The 3-inch rifle and 12-pounder smoothbore were still standard weapons. The author of the 1874 manual, Artillery Tactics, obliquely criticized the state of American materiel with the observation that the 12-pounder ". . . , is still . . . retained in the United States service, though abandoned by all other civilized nations."¹⁰⁷ Artillery carriages had not changed much; they were still rigid, wheeled, firing platforms. And, in general, ammunition had not advanced beyond basic Civil War designs. Percussion detonated shells, however, had clearly exceeded all other types in popularity. The one notable addition to the weaponry of the field artillery occurred in 1868 with the adoption of the Gatling gun, or

mitrailleuse as it was called in an affected resort to French terminology. The mitrailleuse was a small-caliber, rapid-fire, flat-trajectory weapon. The 1/2-inch model fired solid shot; the 1-inch variety fired both solid shot and canister. Like direct-fire cannons, the mitrailleuse held more defensive than offensive potential.

The prevailing concept of the employment of field artillery is reflected in the 1874 edition of Artillery Tactics. Like most other American manuals of the era, this book, intended for soldiers, was published by a civilian firm, in this case, D. Appleton and Company; however, it carried the official imprimatur of the War Department: "By Authority." The manual contains the cumulative digested lessons pertinent to the field artillery from the Civil War and the years that followed. One thing is clear: not much had changed.

Concepts of organization and mission were essentially the same as they had been ten years earlier. Artillery was still classified into two types: light, and heavy. On a war footing, the light, or field artillery, which was to accompany the maneuver army, was to be organized into battalions and brigades in the same way that had been clarified by the Barry Board in 1868. A brigade of light artillery was to be attached to each maneuver corps; or in smaller commands, a battalion, to a division; or if the force were small enough, a battery, to a brigade. There were no high-angle weapons within the active inventory of the light artillery; these were still to be found among the siege and seacoast weapons of the much less mobile heavy artillery.

Methods of aiming cannons had also remained essentially unchanged. Putting a projectile on target was still much more a product of art than it was of science. A gunner's skill and some luck were required for

effective engagement. For example, the following was guidance for estimating range:

With ordinary eyesight, masses of troops are distinguishable at sixteen hundred yards; . . . single figure, one thousand yards; movements of arms and legs at eight hundred yards; . . . faces . . . at three hundred yards; buttons at one hundred and fifty yards; . . . white of the eyes at thirty yards.¹¹⁰

Estimations of deflection were no more precise. Error caused by drift created by wind could ". . . only be corrected by the experience and judgement of the gunner."¹¹¹ And error caused by the drift inherent in the spinning flight of rifled projectiles could be ". . . corrected by pointing more or less to the left depending on range."¹¹² But it was still the era of relatively short-range, low-trajectory weapons, and the errors caused by imprecise methods of aiming were not yet intolerable. As engagement ranges lengthened, initial errors in aiming produced wider deviations in projectile impact. The solution, advised the manual, was calm, deliberate fire.¹¹³

Artillerymen emphasized slow fire even at moderate ranges. Rapid fire was considered to be inaccurate and wasteful. "A heavy fire is produced by concentrating a number of guns on a single point, not by increasing the rapidity of fire of a small number."¹¹⁴ At ranges from 1500 to 3000 yards, one shot per gun every four to six minutes was considered an adequate rate of fire.¹¹⁵ There was an obvious trade off between accuracy and rate of fire that limited the amount of explosives that could be effectively placed on a target.

The 1874 manual clearly reflected the tactical lessons of the Civil War. On the offensive, field artillery was to engage enemy guns with counterbattery fire; on the defensive, it was to concentrate on advancing infantry and cavalry. Continuing respect for the power of

rifled small arms was evident in the instruction to bank earth to the front and sides of cannons that were not protected by natural folds in the ground. Gunners were advised to leave positions that they had not been ordered to hold when enemy infantry closed to within 900 yards. To remain longer would subject a battery to disablement, particularly from the loss of its horses.¹¹⁶ The notable deviation from lessons of the past was the continued reference to an artillery reserve. Neither Grant's wartime elimination of the reserve artillery nor the Prussian success in doing without it could shake the concept from the consciousness of American field artillerymen.

Of course, American insistence on withholding guns from battle and the Prussian tactic of committing all of their weapons were both manifestations of the direct-fire employment of field artillery.¹¹⁷ The American tactic was a holdover from the era of the smoothbore, while that of the Prussians was an adjustment to the age of rifling.

It is clear then, that for a decade after the Civil War, the materiel, organization, and tactics of the American field artillery had remained nearly static. In the pamphlet in which he criticized the lack of technical proficiency among artillerymen, the anonymous gunner also addressed the problem of professional stagnation in the field batteries. The importance of the command of a field battery, he asserted, had greatly decreased. It failed to offer a challenge. There was no hope of recapturing the dash and enterprise that had characterized the days of the smoothbore. In addition, in the field artillery, there were only two types of cannons, and they were fired with fixed charges with just a few degrees of elevation. In contrast, in the heavy artillery, an officer was concerned with twenty different guns, a variety of propelling

charges, and a wide range of elevations. Also, the latest in mechanical
118
devices were used to maneuver the heavy weapons. His message was
clear: a young officer looking for a challenge should be in the coast
artillery.

Such was the state of affairs in the Artillery in the mid-1870's.
The field artillery, in particular, was in a condition of stagnation.
As an active organization it had nearly ceased to exist. Its materiel
and the concepts of its combat organization and tactics had changed
little since the Civil War. The paradigm of direct-fire field artillery
support for the maneuver army was still very much in effect. Any major
change within the paradigm would be tied to the technological evolution
of the mobile artillery materiel--materiel that was still largely ignored
by the Ordnance Department.

CHAPTER VI

1875-1880: A SLOW GATHERING OF TECHNOLOGICAL MOMENTUM

Stephen V. Benét was Dyer's successor. Benét was commissioned in 1849 as an ordnance second lieutenant. Like Dyer, Benét passed more senior members of the Department when he rose in June 1874 from major to brigadier general.¹ Unlike Dyer, his appointment was not clouded in innuendos of political manipulation. The sharp confrontations with congressional committees that marked Dyer's reign over the Department were nearly absent during Benét's administration, but other than that, for the first years at least, the new chief pursued the policies of his predecessor.

Benét's first annual report, in October of 1874, might well have been signed by Dyer. In that report Benét related that the weapons selected by the Heavy Gun Board two years earlier were not yet ready for a trial. The modest effort with field artillery of a year before also had lost its momentum. The one significant step taken in artillery design was the serious consideration of hydraulic buffers for recoil control.²

Europeans had jumped ahead of Americans in the use of fluid compressors to restrict the motion of recoil. In 1873, the English had adapted an oil filled, piston driven cylinder to a heavy gun carriage;³ and at the same time, they began to use the devices for light naval artillery.⁴ When the American Board on Gun-Carriages met in 1873, it had considered an English hydraulic buffer, but it failed to recommend

5
one for test.

Lieutenant Colonel Crispin, the commander of the Ordnance Agency and Arsenal in New York City, informed the Department in 1874 that one of his subordinates, A. G. Sinclair, had invented a hydraulic buffer that was superior to the English design. Crispin was enthusiastic about the buffer. His agency had successfully tested the device on a 15-inch carriage, and he was convinced that it was superior to pneumatic designs in cost and simplicity. ⁶ (Figure 11 shows a hydraulic buffer on a 10-inch carriage.) Sinclair's initiative, under Crispin's sponsorship, had closed the brief gap between American and English achievements in heavy gun recoil control.

The success of the Department with fluid buffers was a distinct contrast to the lack of progress with gun designs. As Dyer had done for several years, Benét asked Congress for funds to purchase cast-iron Rodman guns (Rodman was dead by this time). However the argument took a new form. Benét maintained that an early decision to buy was needed because a restoration of the capacity of American industry to produce the weapons, idle since 1866, would take time. Trees had to be felled for charcoal; and pig-iron casting facilities, long converted to other uses, had to be readapted to ordnance work. To add force to his request, Benét sent letters to Congress from manufacturers appealing for orders for cannons to provide work for ". . . the laboring class, many of whom have been thrown out of employment . . ." ⁷, because of ". . . the present stagnation in business resulting from the late financial ⁸ panic, . . ." The appeal had no effect.

Benét approached the problem in yet a different manner the next year. Through the Secretary of War, he sent to the President a report

FIGURE 11
10-INCH CARRIAGE WITH HYDRAULIC RECOIL CHECK

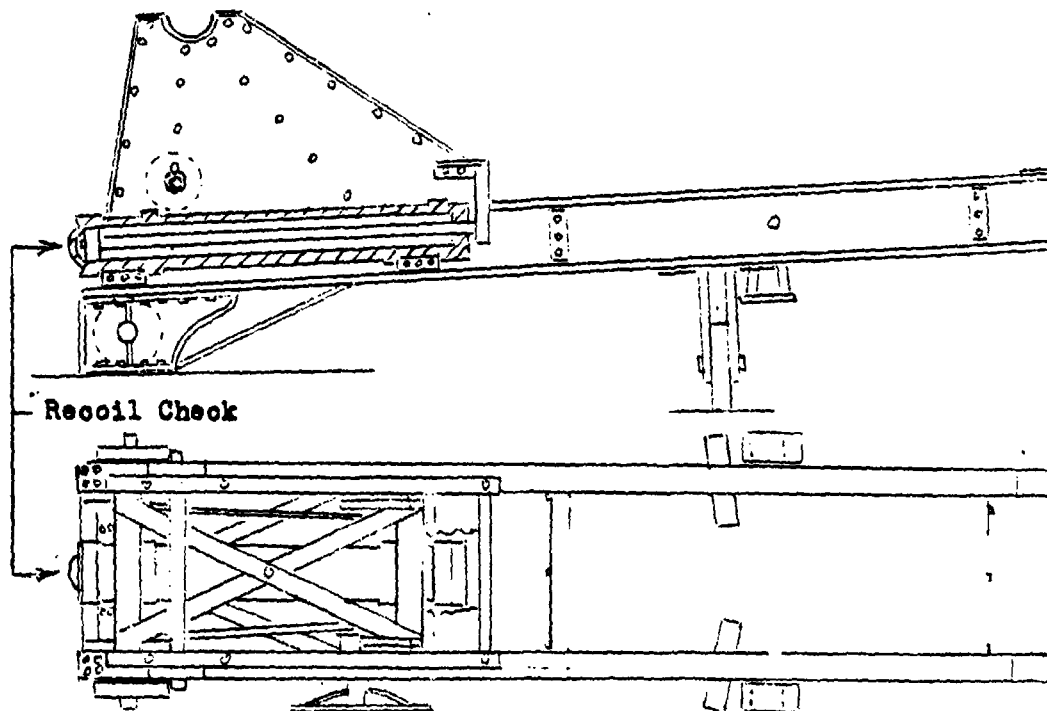

Side and Top View

SOURCE: U.S., Congress, House, Report of the Secretary of War, Ex. Doc. No. 1, 44th Cong., 2d sess., 1876, pt. 2, 3: plate VI.

of the successful test of a 8-inch rifle that had been converted from a 10-inch Rodman smoothbore. In response, in January 1875, Grant took the unusual step of sending a special message to Congress requesting \$250,000 to make additional conversions. Congress responded with \$75,000. Unsatisfied, Benét termed it "A small appropriation"

The 8-inch rifles were based on the plans originated by Crispin and submitted by the Ordnance Department in the competition judged by the 1872 board. The rationale offered by Benét for sponsorship of additional conversions was that although, "There is little doubt that steel is the best material for guns, the product is by far too costly to be considered now, and, besides, would have to be procured abroad." Benét stated that, "We have the best cast-iron gunmetal known, and this plan of conversion enables us to utilize our own products. The wrought-iron tubes can probably be manufactured in this country also." And, as a practical consideration, the casements of the sea-coast forts ". . . , are contracted to accommodate a gun of much larger size than the 10-inch Rodman;" Finally, to give urgency to the appeal, Benét reported that in England there had been a preliminary test of an 81-ton while the United States ". . . , for the want of necessary appropriations is forced to depend on a smooth-bore system and a few small rifles"

Crispin, one of the evaluators in the 1872 heavy gun design competition, was also the Constructor of Ordnance and head of the Ordnance Board, as well as the Commander of the Ordnance Agency and Arsenal in New York. Among his responsibilities were the construction and tests of the weapons recommended by the 1872 board. Benét publicly praised Crispin and the rest of the Ordnance Board in his annual report

report for the excellent work that they had done on the 8-inch pieces.

At the same time that Benét campaigned with vigor for the quick adoption of converted Rodman guns, the Ordnance Department could only report that the rest of the weapons recommended for trial by the 1872 Board on Heavy Cannon were still in preparation. Benét anticipated that some of the weapons would be ready for test in the spring. Department emphasis was clearly on using the converted Rodman muzzle-loaders. There is a strong inclination to infer that there was some procrastination by the Department in the preparation of the other weapons for tests.

England's 81-ton gun, mentioned above, began a new stage in the European heavy artillery race. It was a rifled weapon with a caliber of 14-inch. In contrast, the largest gun constructed by the American Ordnance Department, the 20-inch smoothbore, weighed about 50 tons. The weight of metal in the 81-ton gun permitted the use of heavy propelling charges, which gave it the power to hurl a shot that would penetrate 20 inches of iron armor. Not to be outdone, the Italians soon purchased a 100-ton gun that was said to be able to penetrate 30 inches of armor. Germany then ordered a gun of 124 tons from Krupp; and the British began to talk of one of 200 tons. The race for super heavy weapons was on in Europe; but the Ordnance Department, wrapped up in its own projects, did not become seriously involved in it.

By 1876, the Chief of Ordnance was ready to admit that, at least in casemated works, breech-loading artillery had an advantage over the muzzle-loading variety. As might have been expected, he requested funds to convert rifled Rodman weapons to breechloaders. Several of the long awaited experimental guns approved by the 1872 Board had finally been completed; but at the requests of the inventors they had been sent to

the Centennial Exhibition in Philadelphia. It made little difference--
no funds remained for their tests. ²¹ Benét pointed out that it cost about \$100 for each round fired. Since guns were tested for their endurance, the trial of a 12-inch weapon that could discharge 500 rounds without failure would cost \$50,000. Benét did take steps to secure additional funds for the tests. In the same report that he submitted to Grant requesting \$250,000 for Rodman conversions, he also asked for ²² an equal amount to begin tests on the other experimental weapons. Congress refused to provide another quarter million dollars for the 1872 heavy gun program. It was yet another delay for the non-Department weapons; at the same time, the Chief of Ordnance continued his efforts to salvage the Rodman guns.

In spite of the delay with large weapons, the Department began to work on a Sutcliffe breech design adapted to a 3-inch Ordnance Rifle, figure 12. (The Sutcliffe 9-inch rifle was one of the heavy pieces awaiting tests.) The modified 3-inch rifle would give the Department another breech-loading field piece to test. However, progress was certain to be slow. Although the Moffatt field gun had been available for three years, only 175 rounds had been fired from it; and the tests ²³ were still not complete. Without question, field artillery was of secondary importance to the Department.

Although work was generally stalled on American artillery, the Department had taken steps to gather information on European advances. In 1873, the Secretary of War had directed that Lieutenant Colonel Theodore Laidley and Majors Silas Crispin and James Benton "proceed to England, France, Germany, Austria, and Russia, for the purpose of collecting information in regard to the construction of heavy cannon and

FIGURE 12

SUTCLIFFE BREECH-LOADING FIELD PIECE

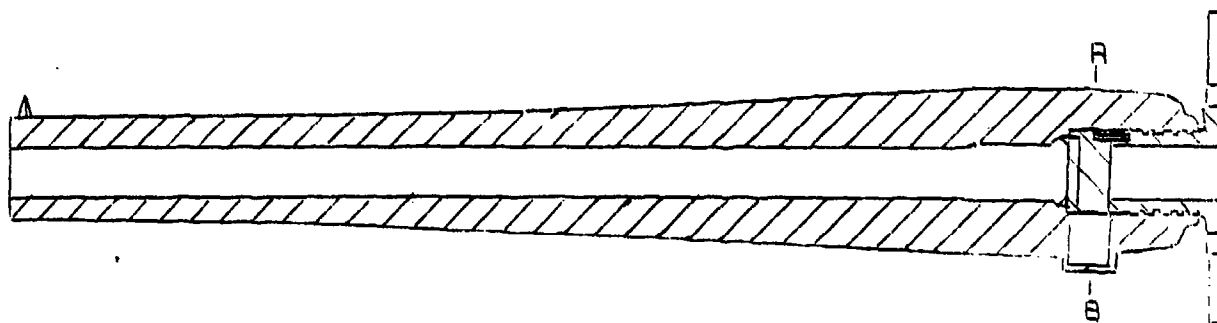

Section A-B

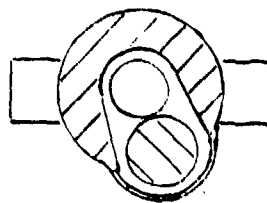

SOURCE: U.S., Congress, House, Report of the Secretary of War, Ex. Doc. No. 1, 44th Cong., 2d sess., 1876, pt. 2, 3:app. h, plate II.

NOTE: The section shows the breech in the open position. A twist of the breech handles rotated the breech plug downward, providing access to the bore for loading. In the upper illustration, a small pin is visible in the top portion of the plug. The pin connected the plug with the rest of the breech mechanism.

other ordnance manufactures." ²⁴ The three officers spent about one hundred days on the mission. However, three years passed before they submitted their reports. Benét cited the demands of other duties as the cause of the delay, ". . . but much of the information gathered has been well digested and already utilized in departmental constructions." ²⁵

The Department showed little hesitation in borrowing the ideas of others for use in its own constructions. In fact, several suits were pending against officers of the Ordnance Department for infringements of American patents. ²⁶ As early as 1869, Dyer had asked Congress for a law that would authorize officers to use, at will, all inventions applicable to the work under their charge, with the provision that aggrieved inventors could submit their claims to a civil tribunal for adjudication. ²⁷ But the Supreme Court ruled against any such plan; and officers who had already allegedly borrowed of the ideas of others were ²⁸ faced with civil suits.

The Department was selective in its borrowing, and as a result, several noteworthy European ideas reported by Laidley's team had not yet been incorporated into its designs. Principally, these lay in the areas of field and siege carriage construction.

The Russians had made some remarkable attempts at improving field carriages. Ten years before Laidley's trip, they had constructed a carriage which permitted the cannon barrel to be traversed without moving the trail. This early attempt at a pivoting field piece was unsuccessful, and the design was abandoned. ²⁹ However, it was an idea before its time; by 1900, a traversing barrel would be indispensable in the design of light artillery. Although there had been several attempts in

Europe to adopt a recoil absorbing spring to field carriages, Colonel Englehardt, of the Russian Imperial Guard seemed to have succeeded where others failed. His carriage featured a recoil absorbing cork cushion set in the middle of the trail, figure 13. In addition, the Russians had placed an iron spike on the end of the trail which was to be driven into the ground by the force of recoil to help check rearward motion.³⁰ These Russian advances were significant design improvements in light carriages, which until this time had recoiled freely. Of course, the advances were but the beginning; carriages still jumped around a bit.

While the Russians excelled in the field carriage design, the Germans made a notable improvement in the area of siege artillery. They adopted a hydraulic buffer to a 15-centimeter (6-inch) carriage. One end of the buffer was fastened to the artillery piece; the other end was bolted to a timber, anchored in the parapet, figure 14. The device reduced recoil to about one yard.³¹

Laidley also reported on the changes that he had seen in heavy mortars. The new models had been rifled and lengthened to the point that the barrels differed little from those of howitzers. They were versatile in that they could deliver fire at any angle of elevation, from 0 to 60 degrees. An Austrian mortar is shown in figure 14. It was certainly more advanced than the Model 1861, smoothbore, 8-inch mortar still being issued by the American Ordnance Department at the end of the decade.³²

It should not be assumed, however, that America was entirely behind the Europeans in ordnance development; the picture was much more complex than that. For instance, when Laidley's team made its inspection, the French did not seem to be adopting hydraulic buffers, and the

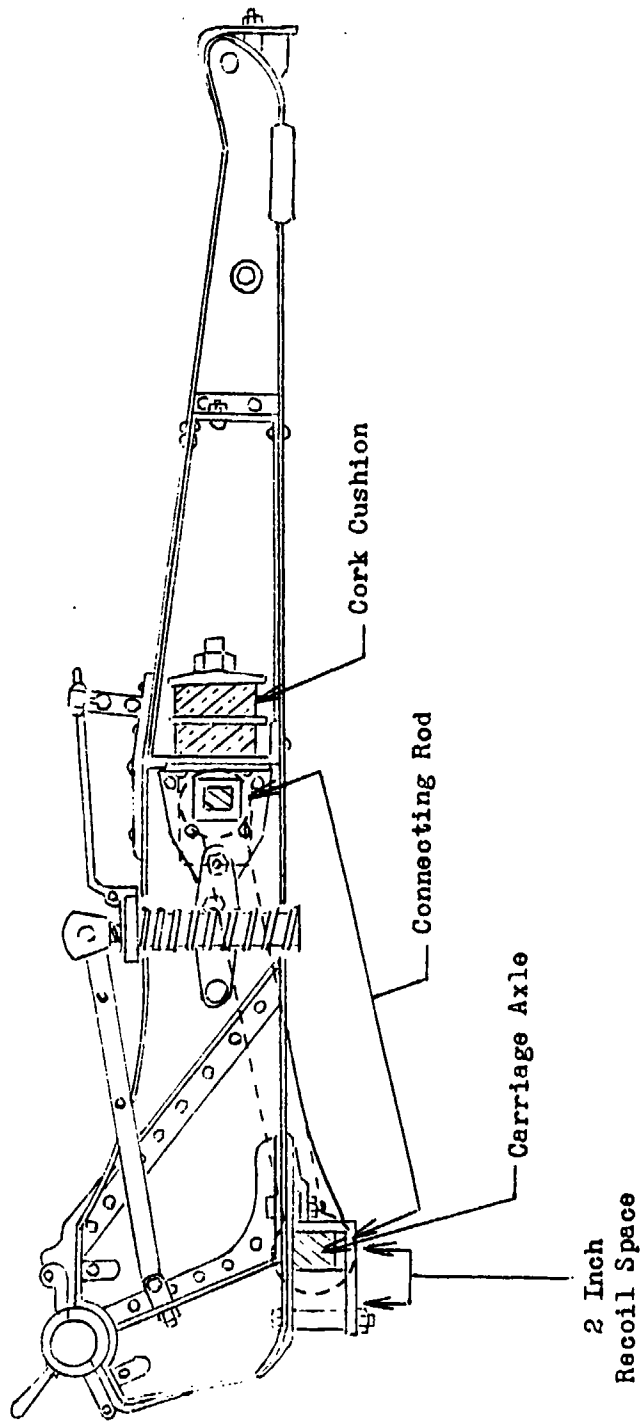
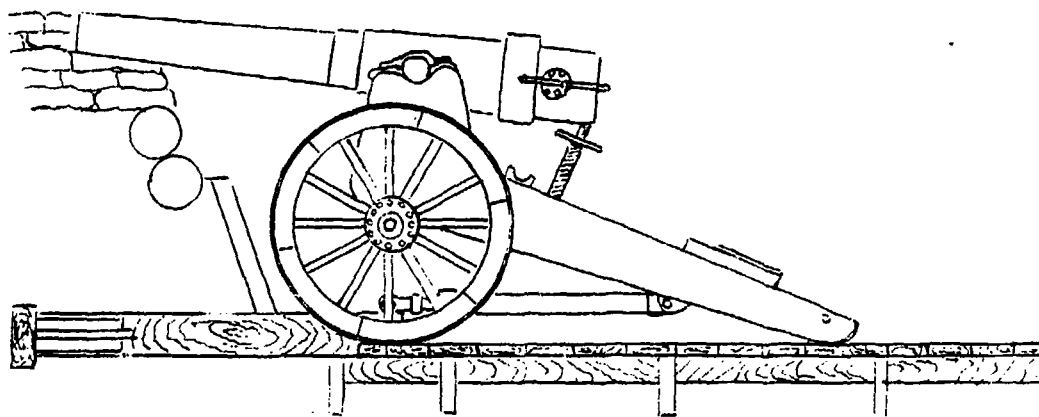

FIGURE 13

ENGELHARDT FIELD CARRIAGE

SOURCE: U.S., War Department, Annual Report of the Secretary of War for the Year 1881 (Washington, D.C.: Government Printing Office, 1882), 3:428, app 37d, plate no. 1.

FIGURE 14
TWO EUROPEAN SIEGE WEAPONS



German 21-Centimeter Siege Gun With
Hydraulic Recoil Buffer

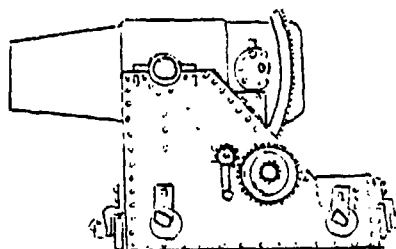

Austrian Mortar

SOURCE: U.S., Congress, House, Report of the Secretary of War, Ex. Doc. No. 1, 45th Cong., 2d sess., 1877, pt. 2, 3:app. K, plates XXXVII, XLI.

NOTE: The hydraulic buffer in the upper figure is connected to the cannon trail and one of the timbers. There is no buffer on the mortar carriage.

Russians, in spite of all their improvement in carriage design, were still casting barrels in bronze.³³

In the years between Laidley's trip and the publication of his report, several ideas had surfaced both in America and Europe which would help to increase the efficiency of artillery. The long engagement ranges of modern guns made target acquisition by the naked eye difficult; as a result, there was a need to adopt some type of visual aid. In 1876, an Englishman wrote:

Artillerymen have been using accurate rifled guns for years, and complaining of the sights; but, for some reason or another, nobody has made the subject his own, or worked steadily to carry into practical execution the belief that there may be perfect accuracy in laying a gun.³⁴

The Englishman was not quite correct in his observation that nobody was working on a solution. The problem of accurately aiming heavy artillery had already produced some forward motion in the employment of telescopic sights. In a letter to the editor of the American Army and Navy Journal in 1874, a subscriber proposed that a directing telescope be mounted on a plane table between heavy guns. Earlier attempts at mounting aiming telescopes directly on cannons had been regarded as impractical, simply because the force of recoil necessitated both the removal of the devices before firing and their adjustment after remounting.³⁵ This suggestion came at the start of a long line of developments that would eventually yield the aiming circle, a device critical in the laying of field artillery for indirect fire. However, the idea of putting a telescope directly on a cannon was not abandoned. For example, in 1876 the British were testing a telescope on their 81-ton gun.³⁶ Continual development of gun mounted telescopes would eventually yield the panoramic field artillery sight, which, with the aiming

circle, would add immeasurably to the efficiency of indirect fire.

In addition to telescopes, the long distance firing of coastal guns also demand an effective means of range estimation. In the age of short-range engagement, fortress commanders would simply give the order to fire; the rest was up to the gunner behind each piece. As engagement ranges lengthened, they became more difficult to estimate. In 1873, a British garrison artilleryman sought to solve the problem with a mechanical, telescopic range finder. The Watkin Depression Range Finder, as it was called, permitted the fortress commander to give a single, accurate range to all of his guns. It was a major step in an evolving concept of fire control. By 1877, the British were even beginning to experiment with range finders for field use. ³⁸ Although, in coming years, the idea of fire control would continue to be driven by the perceived needs of coast defense, much of the concept would be transferred to the field artillery.

The British were also making advances in artillery ammunition. To increase the fragmentation effect of their shells, they began to experiment with the pressure conducting properties of water. They filled cast-iron shells with water and a small bursting charge. The result upon detonation was a high degree of fragmentation of the shell body. ³⁹ The intent, of course, was to increase the antipersonnel effect of artillery ammunition. Although the German approach was not as imaginative as that of the British, it was perhaps more practical. The Germans were relying on strong explosives to increase the fragmentation of shell casings. ⁴⁰ Improvements in ammunition would continue to contribute to the growing efficiency of land artillery.

The problem of the trench, however, was still far from being

solved. The advances in field artillery that were being made in this or that country were, for the most part, disparate achievements; some were still little more than embryonic ideas; and even if they had all been brought together in one system, their collective advantage would not have been a sufficient answer to the trench.

In 1877, the concept of direct fire was given another test of war when the Russians invaded the Balkan possessions of Turkey. Like the War of 1870, it was a short conflict, nine months; but unlike the earlier war, the participation of field artillery was lackluster.

The outnumbered Turkish Army was on the tactical defense. It habitually sought natural cover, and if such protection was lacking, it immediately resorted to the trench. Only rarely did the Turks mount attacks. Instead, they waited in their protected positions to meet Russian assaults with heavy volumes of long-range rifle fire.⁴¹

The Russians had a large numerical superiority over the Turks in field artillery, but in most actions, the effect of the Russian guns was negligible.⁴² A British war correspondent wrote, "The sole instance where any decided success has been achieved, or even aided by artillery was the capture of the redoubt at Telis," He reported that at Loucha, after a 2 1/2 hour bombardment by 50 pieces of artillery, only one Turk had been killed by the fire. And at the great siege of Plevna, where the Russians massed over 500 artillery pieces, ". . . not one yard of the Turkish trenches was ever cleared by shell fire."⁴³ The fortress held out for five months before succumbing to hunger alone.⁴⁴ As the result of his observations, the British correspondent concluded that the usefulness of artillery was greatly diminished.⁴⁵

A molder of American military opinion, the Army and Navy Journal,

in an editorial, took exception to the implication that field and siege artillery had become nearly useless. The editorial recognized the failure of the Russian guns to damage intrenched positions; but it maintained that an army could not do without the weapons, because, at a minimum, they forced defenders under cover. In addition, they were still effective against attacking troops.⁴⁶ It was very much a replay of the perceived status of artillery at the end of the American Civil War.

In apparent contradiction to the poor performance of the Russian artillery in the Balkans, an American witness on a secondary front in the Caucasus wrote that the Russians had driven the defending Turks from their trenches with shrapnel.⁴⁷ Shrapnel was another name for case shot. In 1864, a British ordnance officer altered the design of rifled case shot by moving the detonating charge from the center to the rear of the projectile. When the timed powder train detonated the round in the air over the enemy, the effect was to throw the balls forward in a deadly shower.⁴⁸ It was more efficient than the widely dispersed pattern obtained from a detonating charge in the center of a round. In the future, artillerymen would look to shrapnel as a means to dominate the trench with their low-trajectory weapons; but it proved to be an inadequate solution.

Captain Thilo Von Trotho of the German Army wrote an insightful study of the campaign in the Balkans. His opinion of the performance of the Russian guns was no higher than that of the British correspondent. He observed that against intrenched infantry Russian artillery had little effect. But the Russians compounded the difficulty by keeping their guns directly behind attacking troops, which meant that the fire of the

low-trajectory artillery had to be lifted as soon as the assault commenced. He predicted that in the future light artillery would have to displace forward with the infantry. He made his observation just pages after reporting that the few Russian batteries that advanced with infantry were decimated by rifle fire.⁴⁹ It was a manifestation of the continuing dominance of the doctrine of direct fire in military thinking. As shown previously, some nations were already experimenting with shields to protect exposed gunners from defensive fires. In a second prediction he forecasted a trend toward the development of heavier weapons to accompany the field army. He felt that guns of greater size would be needed if earthworks were to be damaged.⁵⁰ What is missing from his observations is the role that vertical fire might play in such destruction.

Vertical fire was still an auxiliary capability to be called upon by well equipped armies for special siege applications; but the record does not indicate that the Russians employed the method at Plevna. Perhaps it was to prevent a recurrence of the deficiency in the future that they equipped twenty-four batteries with new 152mm (6-inch) field mortars.⁵¹

Also, the Russians ordered fifteen hundred steel guns from Krupp. Just five years earlier, in 1872, at great expense, they had rearmed their artillery with bronze weapons. The metal proved to be inadequate for modern artillery when it was tested in combat.⁵² The fame of steel was growing.

The Russo-Turkish War provided at least two artillery lessons. The first one was the inadequacy of bronze as a metal for modern field guns. The second lesson was a reinforcement of the experience of the

American Civil War--that field fortifications could significantly reduce the power of artillery. The battlefield reputation of field artillery, somewhat restored in the Franco-Prussian War, was again eroded, although shrapnel seemed to promise a second restoration.

While shrapnel was beginning to capture the imagination of artillerymen, some work was in progress on the improvement of high-angle fire. In the siege of Paris in 1870, the Prussians had employed guns from defilade positions, using aiming methods similar to those of the American Civil War, that is by sighting forward along lines marked on firing platforms. In 1877, the Russians adopted a system of reverse pointing for their heavy coastal guns. A large arc with marked angles was drawn to the rear of a weapon. The gunner would then sight from the weapon back to the appropriate angle.⁵³ In 1878, to improve upon the accuracy of defilade fire from siege pieces, the British began to experiment with another method of reverse pointing. They aligned two pickets at the rear of a gun and then aimed the weapon by sighting through the tangent scale back at the stakes.⁵⁴ In later years, this system of pointing, with some improvement in technique, became known as "indirect lay," and it is the method by which most artillery is aimed today.

The accuracy of high-angle weapons, however was still far from good. The British High-Angle Fire Committee conducted an elaborate series of tests with howitzers, and the results were disappointing:

. . . the difficulty of obtaining even approximate accuracy of aim with vertical fire especially at long ranges, is felt to have been scarcely diminished by all the study and practice which have been devoted to it.⁵⁵

56

The committee concluded that recoil had much to do with the problem. Experiments proved that the 6.3-inch howitzer, when fired from its field

carriage, had an average error in a range of 62 yards. If the carriage was weighted with 3 tons of iron, the error was reduced to 34 yards. If the carriage was tightly lashed to a fixed platform, the error could be reduced to 11 yards.

Fixed platforms, however, were part of the equipment of deliberate siege warfare. The German adoption of a hydraulic buffer to a siege gun and the British experiment with lashing, both depended on heavy wooden platforms. Early attempts at recoil control in siege artillery tended to bind it even more tightly to its specialized role in position warfare.

To some extent, the easy availability of railroad transportation was adding to the tactical immobility of siege artillery in Europe. Railroads were making it possible to move guns of almost unlimited size. The large pieces moved by rail had immobile carriages similar to heavy coast defense weapons. Of course, not all siege artillery was of the super heavy variety. But, like improvements in accuracy, major advances in throw-weight tended to bind siege pieces to their traditional role as specialized weapons of position.

More than a generation would pass before automotive power would provide tactical mobility to guns of large size; but initial attempts at the military use of mechanical transportation appeared as early as the 1870's. In 1876, the Russians conducted a military test on traveling steam engines imported from England. They found that the machines could propel 2,500 pounds on good roads and that they were not unreasonably restricted by bad ones. Four years later, at Le Mans, a French military committee tested similar vehicles, called traction engines. Loaded vehicles weighing up to 15,000 pounds successfully negotiated steep

grades on the streets of Le Mans. And one traction engine was driven
along a highway for 480 miles at an average rate of 6 miles per hour.⁶⁰
These tests were but the modest birth of another idea that appeared well
before its time, and nothing much would come of it for many years. In
the United States, the tests were all but ignored.

The telephone had a little better reception. Alexander Graham
Bell's 1876 invention was hardly a year old when the New York Telephone
Company provided equipment to report target strikes to the firing line
during an international rifle match. The demonstration prompted the
Army and Navy Journal to urge the military adoption of the device.⁶¹

German authorities may or may not have known about the rifle match and
the Journal editorial, but they did not hesitate to test the telephone.
The initial field evaluation was inconclusive; transmissions over the
new device were difficult to understand.⁶² However, the telephone was
improved enough by the end of the decade that the French Army adopted
a portable field model that promised to be useful in artillery practice
and siege operations, among other applications.⁶³ It is ironic that
Europeans were the first to attempt to exploit the military potential
of this American invention.

The Artillery School did recognize that the use of electricity
might help to increase the accuracy of fire. By 1878, it created a
laboratory for experimenting with artillery related applications of
electricity.⁶⁴ And by 1881, it was using a telegraph line to report
the results of target firing from an impact area.⁶⁵ Within five years,
the school replaced the telegraph with the telephone in its seacoast
practice.⁶⁶ The school's action, however, was simply a local initiative.

The United States Army was slow to begin the development of a

field telephone. The Signal Corps, the proponent agency for communications equipment, was deeply involved with national weather bureau responsibilities from 1870 to 1890. These civil duties detracted from the military responsibilities of the small Corps. ⁶⁷ It was not until 1887, that the Corps began to seriously consider the adoption of a field telephone, ⁶⁸ although a lack of funds would continue to hinder its ⁶⁹ development.

The initiative taken by the Artillery School in the establishment of its electricity laboratory is evidence of the value of the institution in the enhancement of the professionalism of young officers. In fact, in 1876, the school had been increased to a two year course. ⁷⁰ Unfortunately, however, the tenuous connection between the Ordnance Department and the Artillery that had been maintained in the person of the Ordnance member of the school staff was broken in 1875 when the ⁷¹ position was abolished.

The Ordnance Department continued its fixation on guns of its own design. In 1878, Benét announced that since the experimental conversion of 10-inch Rodman smoothbores to 8-inch rifles was a success, his Department was proceeding with the next step: the trial conversion of 15-inch smoothbores to 11-inch rifles. At the same time, borrowing Krupp's breech design, Ordnance engineers built a rear loading piece from one of the 8-inch rifles. As if to dissociate himself from earlier departmental resistance to breech-loading, Benét pointed out in his annual report that two years previously he had advocated the adoption of the idea of loading heavy cannons from the rear. ⁷²

In January 1879, a 12 1/2-inch, muzzle-loading cannon burst in a turret of the British warship Thunderer. ⁷³ An investigating committee

determined that the accident happened when seamen had unknowingly loaded the weapon with a double charge.⁷⁴ The mistake could not have happened with a breech-loader; the first charge would have been visible upon an attempt to load the second one. The success of the Krupp breech, combined with the Thunderer accident, prompted Benét to observe that the universal adoption of breech-loading was just a matter of time. And he concluded that, in any event, the large charges and long bores of modern weapons were making muzzle-loading decidedly difficult.⁷⁵ The year of 1879 was, in effect, the beginning of the end of the muzzle-loading era in American ordnance.

While the Department proceeded with an 8-inch breechloader of its own design, the tests of the other weapons recommended by the 1872 board were stalled. As of 1879, the Woodbridge gun had been fired but ten rounds; the Thompson, two; the Sutcliffe, twenty-six; the Mann, eleven; and the Lyman, three.⁷⁶

It must be said again that Benét had tried to secure funds for the tests. Grant had relayed his request for \$250,000 in 1875; and Benét repeated the appeal to Congress in 1876 and 1878.⁷⁷ In 1880, he reduced the request to \$117,600, which would ". . . enable me to have the merits of these different systems fully determined."⁷⁸ Perhaps it was still too much for a program that was supposed to be concluded within the initial appropriation. Congress failed to provide the additional funds, and the guns lay rusting at Sandy Hook as the decade closed.

Meanwhile, Benét had used the limited appropriations for seacoast armament for 1878-1879 to continue the conversion of 8-inch rifles and appealed for more.⁷⁹ Congress responded the next year with a generous

\$400,000 appropriation, which included the requirement that four improved, breech-loading, twelve-inch rifles be manufactured. In contrast to the 1372 appropriation, Congress did not stipulate that the designs were to come from any particular source, and Benét remarked, "It . . . clearly appeared that the selection of the system was left ⁸⁰ to the Ordnance Department." Relations between the Department and Congress were not as tense as they had been in the early 1870's.

There had recently been one other advance in heavy ordnance design: chambering. The concept of leaving an airspace around the propelling charge in an artillery piece was actually an old idea. Admiral John A. B. Dahlgren of the United States Navy, had done some ⁸¹ initial work with the concept in 1850; and by 1864 Confederate ordnance men had determined that the strain on a 7-inch gun could be reduced by 50 percent without a loss in muzzle velocity simply by leaving ⁸² a half-inch of space around the powder. However, the idea remained dormant until the Italians used it in 1876 to reduce the tremendous pressure in their 100-ton cannon. After thorough tests, they found chambering offered three benefits: decreased pressure on the breech ⁸³ area, higher muzzle velocity, and greater shot energy.

Benét picked up the idea, and, in 1879, the Department chambered and successfully tested a 3-inch Ordnance Rifle, figure 15. Benét did not choose a field piece because of his concern for the improvement of light artillery; it was simply an economy measure--it was a cheaper ⁸⁴ experiment than modifying a heavy gun. After the successful test of the 3-inch piece, Benét ordered the chambering of an 8-inch rifle. The ⁸⁵ test with the larger weapon was also successful. At the same time that the Department began its work with the 3-inch piece, it began to

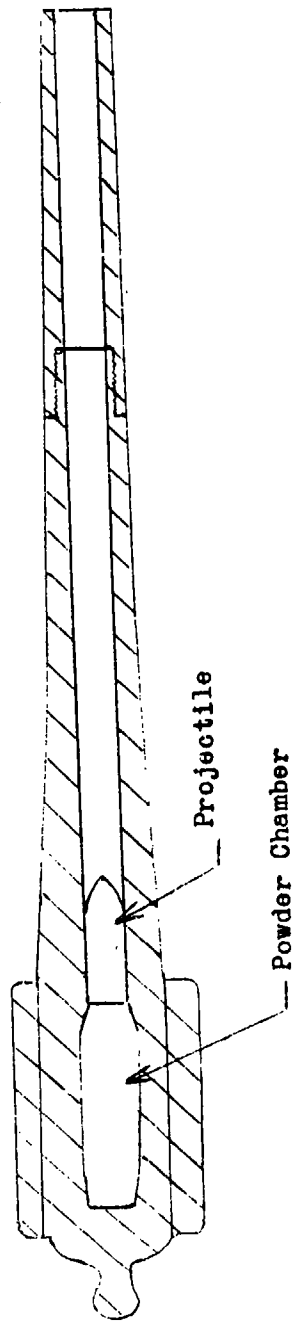

FIGURE 15

3-INCH, MUZZLE-LOADING, CHAMBERED RIFLE

SOURCE: U.S., Congress, House, Report of the Secretary of War, Ex. Doc. No. 1, 46th Cong., 2d sess., 1879, pt. 2, 3:72, plate.

NOTE: As a necessary part of the chambering process, the bore was enlarged to 3.15-inch. In addition, the experimental weapon was lengthened, and the breech was reinforced by a band of wrought iron.

consider the construction of a chambered, breech-loading, 4.5-inch⁸⁶ rifle. It was the only move the Department had made in fifteen years toward the improvement of siege materiel.

The record of the Department in the area of field artillery was not impressive. Although the Moffatt gun had been available since 1873 nothing much had been done with it. A 3-inch piece with a Sutcliffe breech was received at the proving ground in 1876, but after a satisfactory test of fifty-three rounds, it also lay silent. A bronze, muzzle-loading Dean 3.5-inch gun was procured in 1877 and tested for fifty rounds. The design was already out of date before the barrel⁸⁷ cooled, so it also led nowhere.

The single enthusiasm shown by Benét for a field artillery⁸⁸ design was one offered by Colonel Crispin, the Constructor of Ordnance. In 1878, he proposed the adaption of a Krupp breech to a 3-inch service⁸⁹ rifle. Chambering, adopted a year earlier by the Department in an effort to improve heavy artillery, was included in the plan for the construction of the new field piece. The weapon was successful; and Benét announced in 1880 that six of the experimental guns were being prepared to issue to the artillery for field tests. One advantage to Crispin's design, said Benét, was ". . . , we are enabled to utilize⁹⁰ the large number of muzzle-loading wrought-iron guns now on hand." One cannot escape the suspicion that the old pattern of Department preference for guns of its own design was repeating itself.

Virtually nothing had been done toward the improvement of field artillery carriages since the wrought-iron design of Rodman and Benton fourteen years earlier. Their plan had gathered dust in the Department's files. As Benét said, "The introduction of metal carriages for the

field service has not been a necessity until now, because of the large supply of those made of wood," ⁹¹ In 1880, however, the Department began to consider a metal carriage for the new breech-loading ⁹² chambered field gun.

The Department did not have a tradition of involvement in the design of rapid-fire artillery; the field was left to civilians. Perhaps, to some extent, the absence of involvement increased the receptiveness of the Department to the Hotchkiss revolving cannon. The Hotchkiss weapon was not a mitrailleuse, but neither was it a field gun, at least not in the traditional sense, figure 16. With five rotating 1.5-inch barrels, and Gatling-like rapidity, it fired explosive ammunition to a range of 5,500 yards. ⁹³ The inventor was Benjamin B. Hotchkiss, an American who had manufactured arms during the Civil War; ⁹⁴ by 1870, he had moved his office to France. The American Ordnance Department secured one of the new revolving cannons--of French Government manufacture--for a test that began in 1876 and ended in 1878. The Ordnance officials who examined the gun were impressed by its performance. ⁹⁵ They concluded that it would be a valuable auxiliary to light artillery.

Its equality in range, its greater capacity for delivering a deadly, incessant, and widespread fire at all field-ranges, and with a decidedly superior rapidity; its stability when fired, abolishing all but the ordinary initial pointings [the benefit of a small caliber], give it some decided advantages, apparently, over our ordinary field-guns.

For the effects of artillery-fire, however, where penetration is desirable, and where destructive effects of solid shot and shell, in rapidly demolishing large objects, , are required, we must, of course, yield the advantage to the larger calibered field pieces. ⁹⁶

At close ranges, the Ordnance board felt that the Hotchkiss surpassed ⁹⁷ the effect of standard canister, and even shrapnel fire. As a result of the successful tests, the Department procured and issued two of the

FIGURE 16
HOTCHKISS REVOLVING CANNON, 1.5-INCH

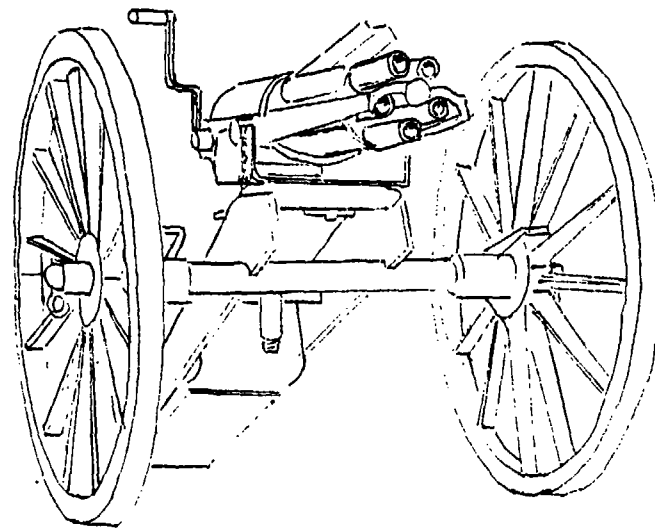

SOURCE: U.S., Congress, House, Report of the Secretary of War, Ex. Doc. No. 1, 46th Cong., 2d sess., 1879, pt. 2, 3:app 14, plate II.

Hotchkiss weapons to the Army in 1880. Although there was much interest in the Hotchkiss, it was to remain an auxiliary weapon, as the efficiency of field artillery improved through the next decade.

As of 1880, although some experimental work was in progress, the artillery materiel listed as standard by the Army had not really changed since the Civil War, table 5. The principal exception, of course, was the addition of rapid-fire, small-caliber weapons.

There is not much to be said about the practical application of field artillery in the United States during the decade of the 1870's. There was little requirement for artillery in the highly mobile campaigns against the Indians. When artillery was used, it was almost always manned by details of infantry or cavalry, a situation that angered Colonel Henry J. Hunt. However, the anger of Hunt, the artillery activist, was wasted. The cold reality of the situation was simply that the light batteries had nearly ceased to exist a decade earlier; and it was not until 1882 that their number was again restored to ten.

Although there was not much to be learned from recent American experience, ordnance designers were exposed to theory from abroad. The Department carried an interesting essay on the development of field artillery materiel in its informative publication Ordnance Notes. In 1879, Lieutenant F. M. Goold-Adams, an Englishman, won a gold medal from the Royal Artillery Institution for the essay. In his paper, he captured much of the trend of field artillery improvement over the next two decades. He proposed that muzzle velocities be greatly increased in order to provide flat trajectories. The "evil" of curved trajectories, he said, was that they required an exact knowledge of range. In addition, a curved angle of impact caused percussion projectiles to

TABLE 5

U.S. ARMY ARTILLERY CLASSIFIED AS STANDARD AS OF 1880

<u>Light guns</u>	Model
3-inch rifled, wrought-iron	1861
3.5-inch rifled, wrought-iron	1868*
1.65-inch rifled, steel breech-loading Hotchkiss mountain gun	-**
4.62-inch smoothbore, bronze (Napoleon)	1857
1.45-inch [1.5-inch], Hotchkiss revolving gun	-
1-inch Gatling guns	-
0.5-inch Gatling guns	-
0.45-inch Gatling guns	-
 <u>Siege, garrison, and seacoast guns</u>	
4.5-inch rifled, cast-iron	1861
8-inch rifled, cast-iron	
10-inch rifled, cast-iron	1871***
11-inch rifled, cast-iron	to
12-inch rifled, cast-iron	1874
8-inch rifled, breech-loading, cast-iron	
10-inch smoothbore, cast-iron	1861
15-inch smoothbore, cast-iron	1861 and 1874***
20-inch smoothbore, cast-iron	1861
 <u>Howitzers</u>	
Mountain, 4.62-inch smoothbore, bronze	1861
Siege and garrison, 8-inch smoothbore, cast-iron	1861
 <u>Mortars</u>	
Siege, 8-inch smoothbore, cast-iron	1861
Seacoast, 10-inch smoothbore, cast-iron	1861
Seacoast, 13-inch smoothbore, cast-iron	1861
Coehorn 5.62-inch [5.82-inch] smoothbore bronze	1841

SOURCE: U.S., Congress, House, Report of the Secretary of War,
Ex. Doc. No. 1, 46th Cong., 3d sess., 1880, pt. 2, p. 59.

NOTES:

*The design was adopted as standard but the weapon was not produced.

**Weapons that were not designed by the Ordnance Department had no model numbers. See note number 89, this chapter, for a brief discussion of the mountain gun.

***Altered Rodman weapons.

bury themselves before exploding, reducing their effect. Also, he asserted that curved fire reduced the coverage of shrapnel, by throwing it into the ground in a tighter pattern than might be had with a flatter trajectory. To protect gunners from infantry fire at close ranges he advised the use of some type of protective screen. ¹⁰¹ Of low-trajectory guns he said:

The artillery must now come to the front, and by its fire render works untenable, or at least shake the moral force of the defense to such a degree as to render an attack possible. For this purpose great accuracy, . . . weight and velocity of shell, and a powerful bursting charge are necessary. ¹⁰²

He did not ignore vertical fire. He advised the reintroduction of howitzers into field service, because, he said, there would be numerous instances when troops could only be dislodged by accurate and powerful high-angle fire. But he maintained that the weapons should not be given to the division; they should be retained at the corps. ¹⁰³

Of the cannon shell used to destroy field fortifications he remarked:

Although this projectile is not so important as shrapnel, since the chief function of field artillery seems to be that of firing at troops in the open, yet the increased importance given to field fortification demands that artillery be prepared to make advances in its power of destroying materiel. ¹⁰⁴

It is a telling essay, because on one hand, it accentuates the importance of direct-fire artillery, calling for its continued perfection and accentuating its primacy; yet on the other hand, it recognizes that there would be occasions when only vertical fire could dislodge troops from trenches. It is important to note that the author advises providing the maneuver army with a vertical fire capability, although it is to be restricted to the level of the corps. It is a subtle shift in the perception of the proper locus of the capability--

from the sole possession of the siege train to the partial ownership of the maneuver forces. The improved accuracy of rifled over smooth-bore delivery, combined with the effective use of the trench in the Russo-Turkish War, was making high-angle fire look better; but its application was still a long way from what would come to be the doctrine of indirect fire.

The decade of the 1870's was a seedground of modern artillery development. Nearly all of the necessary technological ingredients for indirect fire, embryonic as many were, had appeared before the decade closed. It may be recalled from chapter 2 that, when it would appear in the future, the concept of the indirect fire employment of field artillery would depend on massed, accurate, high-trajectory bombardment.

Mass would be a derivative of many things--numbers is the most obvious--but numbers alone would be shadowed by improvements in materiel and technique that contributed to mass. Steel gun construction would give barrels the strength, without making them prohibitively heavy, to use powerful propelling charges to fire large projectiles to long distances. Chambering would contribute to the ability by reducing internal pressure on cannon metal, which made the use of even more powerful charges possible. The range advantage meant that the fire of guns from several parts of the battlefield could be concentrated on a single target. Of course, some method of communication was needed to tie the many guns together. The telephone would provide the answer. And no small advantage was to be gained by recoil control and breech-loading which would permit higher rates of fire. Significant advances were yet to come in shell design, but work was progressing in Europe on more efficient burst effects. All of these factors, already present

some degree in the 1870's, would contribute to the mass necessary for the indirect-fire concept.

Like mass, accuracy would also be the product of many things. The effect of rifling was already being felt. Accuracy would also depend upon the improvement of sighting techniques. The use of telescopes with heavy guns, and aiming stakes with siege artillery had already begun to appear in Europe. In addition, the developing techniques of recoil control would be no less important to accuracy than they would be to mass.

High-trajectory bombardment was an idea as old as artillery itself; but it was still a specialized technique. The coming together of the ingredients listed above for mass and accuracy would make it a viable replacement for the technique of direct fire. But as of 1880, several of the ingredients were still disparate achievements. Certainly no nation had yet brought them together in an effective system of indirect fire for the artillery of a maneuver army.

It is important to note the derivations of the ingredients. Rifling, steel construction, and breech-loading first appeared in light artillery, where the technological difficulty of their adoption was less than in the larger calibers; but, taking the American example, the principal motivation behind the continued development of these ingredients was the perfection of heavy artillery. Recoil control, the use of aiming telescopes, embryonic concepts of fire direction, back-sighting, and chambering were devised to meet the needs of heavy artillery. And, of course, much of the basic technology of metallurgy and optics was civilian in origin, as was the telephone. Hopefully without belaboring the obvious, the point is that much of the technological advance that

would eventually make the doctrine of indirect fire possible was unrelated in its derivation to the perceived needs of the field artillery.

In the United States, the principal agency of military technological change, the Ordnance Department, had operated since the Civil War under several handicaps; some were self-inflicted. The Department displayed an obstinate predilection for designs of its own origination. The problem was that while the Department pursued its own designs, borrowing selectively from the work of others, time was lost in the acquisition process. In the areas of field and siege artillery the habit of slow acquisition was no more of a detriment than the virtual neglect of effort. The needs of coast defense dominated the artillery related efforts of the Department. It was not until the decade closed that any significant move was made in the improvement of field artillery materiel; and siege weapons had yet to excite more than the briefest interest.

On the other hand, two things need to be said in defense of the Department. First, the only real perceived threat to the nation was naval bombardment of cities. Second, Benét, like Dyer before him, put emphasis on the economy of converting old weapons, as opposed to the expense of building new ones. Of course, it is difficult to completely separate this motive of economy from the Department's habitual preference for guns of its own design--those that were to be converted.

Finally, there was the matter of the relations within the decisionmaking process as the decade closed. The Secretary of War invariably gave official support to the activities of his subordinate, the Chief of Ordnance. And although the Commanding General of the

Army was not in the staff agency chain of command, his views on weapons development were usually consistent with those of the Chief of Ordnance. Artillerymen, the users of ordnance materiel, were still involved in the decisionmaking process in only the most tangential way--board participation, usually as a minority. Perhaps most important, the difficulties with Congress that had characterized Dyer's administration had abated significantly by the end of Benét's first five years in office. In effect, the locus of decisionmaking authority on weapons development still rested with the Chief of Ordnance, even more firmly than five years earlier.

CHAPTER VII

1881-1888: FIRST MOTION IN THE DEVELOPMENT OF MOBILE ARTILLERY

The guns of modern armies lay quiet during the 1880's. Of course, there was the occasional whiff of gunpowder in far-flung lands; but meaningful experience with war was left to contemplation of the lessons of the past and theories about the future.

In the United States, the coast artillery rose to new heights of importance. Field and then siege artillery rose in the shadow of the climb, impelled by moderate attention, after years of nearly total neglect. The efforts of the Ordnance Department with the lighter types of artillery were unhurried, casual, and almost an afterthought, but at last there was motion. Real attention was focused on the requirements of coast defense, and the Department's too often repeated pattern of preference for its own designs put it once again on a collision course with Congress.

In January 1881, a subcommittee of the Senate Committee on Appropriations began hearings to determine the amount of money to be allotted to the armament of coast defenses for the following year. Norman Wiard, a civilian inventor and unremitting nemesis of the ordnance bureaus of both the Army and Navy, requested permission to appear before the subcommittee. His complaint was that the four 12-inch rifles recently selected by Benét for manufacture and test were the patented inventions of Lieutenant Colonel Silas Crispin, who held Rodman's old

job of Constructor of Ordnance. Also, he was president of the Ordnance Board. When the Department became seriously interested in breech-loading heavy artillery, Crispin, as President of the Ordnance Board, recommended to Benét that converted Rodman guns be modified to accept a breech mechanism. The problem, as Wiard saw it, was that in 1879 Crispin had secured a patent on the method by which the Rodman smoothbores were converted to rifles. He implied that Crispin had profited from the conversion of muzzle-loading smoothbores and that he stood to gain again as the Department began a program to develop breechloaders of its own design.

Benét was present at the airing of Wiard's charges. The Chief of Ordnance stated that he knew little of Crispin's patent arrangements. He added that under the law an officer was not prohibited from holding a patent; and in any event, he did not know of any money that Crispin had received for his invention. William P. Hunt, president of the South Boston Iron Company and manufacturer of the proposed 12-inch weapons, confirmed that there had been no arrangements to pay Crispin for his patent. In fact, he added, it was not clear that Crispin's patent was valid, because it conflicted with the claims of other inventors. The subcommittee was unable to question Crispin himself about the patent arrangements; Benét confirmed that the Constructor of Ordnance was sick in New York and unable to testify.

Although an officer might reject any compensation but honor when the Army used his invention, a patent still held the promise of pecuniary reward. If the invention became a military success, subsequent civilian or foreign use of it would be subject to the payment of royalties. As one subcommittee member, Senator Allison Beak said, ". . . I think it

is . . . his duty when his own invention comes up before a board of which he is president, to decline to act on the ground that he is interested,"³ It was sound advice. In view of the record of criticism received by the Department, it is surprising that officers were not prohibited by agency rules from judging their own inventions.

There was also some concern among the subcommittee for the high cost of the 12-inch guns, \$46,000 each. It appeared that Krupp was then willing to sell steel guns of the same caliber for \$30,000. Part of the high cost of the American weapon was attributed to the need to import steel for the breechblock from England.⁴

Alternate American designs for breechloaders had been available since the 1872 board, but the guns produced from those plans had not been tested enough to keep the barrels from rusting in the salt air at Sandy Hook. The civilian inventor of one of the guns, H. F. Mann, summed up his frustration before the subcommittee when he was asked if he sought a continued test for his weapon. Mann replied:

No, sir; it is perfect nonsense for me to waste time and expense to have that gun taken up and have half dozen shots fired here and half a dozen there. That does not amount to anything. It is simply to keep us crazy inventors, as they consider us, quiet; but they are developing their own plans [for guns].⁵

The subcommittee investigations ended nearly a decade of congressional non-interference in Department activities. The appropriations bill passed in March 1881 provided for the establishment of a board of officers to examine all inventions of heavy ordnance, to include guns under construction or conversion by the Department. The board was to make recommendations on weapons to be tested to Congress, through the Secretary of War. It consisted of one officer of the Corps of Engineers, two of the Ordnance Department, and two of the Artillery.

The two ordnance representatives were Colonel James Benton and Major Adelbert R. Buffington (who in 1899 would become Chief of Ordnance).⁶

The board began its deliberations in July 1881 and reported to Congress the following May. It recommended for tests the weapons shown in table 6. Noticeably absent from the list was Crispin's proposed 12-inch gun. The board gave the questionable performance of wrought-iron conversion tubes as the reason for the rejection. Also rejected was Wiard's proposal to rifle existing cast-iron artillery: "The Board does not approve of the conversion of any of the smooth-bore guns . . . , and particularly does not approve of the system or systems proposed by Mr. Wiard."⁷ Wiard's plan was simply to rifle the cast-iron bores of the old guns. He boldly admitted that the process would cost him only \$40 per weapon, although he proposed to charge the government \$500.⁸ If Wiard expected the government to pay him such a profit, he was not an entirely rational fellow; but at least his complaint to Congress helped to initiate a board outside of the Ordnance Department that had the power to give a new direction to heavy artillery acquisition. The board's subsequent recommendations did much to lay to rest the lingering episode of heavy ordnance selection that had been initiated by congressional interposition in 1872 and marked by apparent Department "foot dragging" since that time.

The hearings before the subcommittee in 1881 received notice in the national press. The Army and Navy Journal, closely attuned as it was to items of military interest, was critical, in both its editorials and in some of its printed "letters to the editor," of the Department's original selection of the Crispin guns.⁹ The Boston Daily Advertiser¹⁰ also attacked the ordnance bureau.

TABLE 6

WEAPONS RECOMMENDED BY THE GETTY BOARD, 1882

Rifled guns

Lyman-Haskell Multicharge Gun, 6-inch

W. E. Woodbridge's wire-wound, cast-iron, B. L.* gun, 10-inch

W. E. Woodbridge's wire-wound, steel tube, B. L. gun, 10-inch

W. E. Woodbridge's wire-wound, steel bars, B. L. gun, 10-inch

W. P. Hunt's steel, B. L. gun, 10-inch

Wire-wound, steel, B. L. gun, 9-inch, on the Schultz plan submitted by
Silas Crispin

Cast-iron hooped with steel, B. L. gun, 12-inch, submitted by the
Chief of Ordnance

Cast-iron tubed and hooped with steel, B. L. gun, 12-inch, submitted
by the Chief of Ordnance

Wire-wound, B. L. gun, 8-inch, submitted by the Chief of Ordnance

Rifled mortars

Chief of Ordnance's cast-iron hooped with steel, M. L. ** mortar,
12-inch

SOURCE: U.S., War Department, Annual Report of the Secretary
of War for the Year 1882 (Washington, D.C.: Government Printing Office,
1882), 3:7.

NOTES:

*B. L. = breech-loading

** M. L. = muzzle-loading

The pressure of the events of 1881 strongly suggests that the embarrassment suffered by the Department might have precipitated Colonel Crispin's relief in November from his duties as Constructor of Ordnance and member of the Ordnance Board. However, he remained in charge of the Ordnance Agency in New York.¹¹

Like Rodman before him, Crispin was a man of substantial talent; but the system was such that it invited the suspicion that these men and others in the Department abused their authority. The action of the Congress in once again placing the question of ordnance selection in the hands of a War Department board was a corrective measure in the decisionmaking process. In fact, the action began a string of congressionally initiated ordnance boards: the Gun Foundry Board was called pursuant to the act of 5 July 1884; and the Fortification Board¹² assembled after the act of 3 March 1885.

Perhaps the greatest benefit to come from the work of the 1881 board was that it did much to break the grip of the Rodman system of cast-iron construction. Crispin's 12-inch rifle was but another attempt to perpetuate the basic cast-iron design. During the 1870's, the Department had added wrought-iron tubes to cast-iron guns to give them strength to take rifling. The next step was to adopt a steel breech to the weapons so that they might be loaded from the rear. In 1881, converted cast-iron rifles of 8- and 11-inch caliber were fitted with¹³ breech receivers on the Krupp system; both weapons failed in tests. The board's rejection of the Crispin 12-inch designs effectively ended the era of the consuming commitment of the Department to cast-iron construction. It was an important event, because attention would now be turned to steel.

It was not simply a matter of dropping one metal for another. In his annual report for 1882, Benét observed that to meet the needs of coast defense guns of "moderate power" could be constructed from a combination of steel and cast-iron. Although such guns would be very heavy in proportion to their power, they would optimize the use of a national resource, cast iron. Since the national ability to produce gun steel was small, Benét thought it best to reinforce the cast iron with wraps of steel wire, a more economical use of the metal than
 14
 hoops or bands.

For an industry not yet adapted to the production of gun steel, even Benét's modest plans would take time. In 1883, to meet the immediate needs of coast defense, Congress provided for the conversion of
 15
 fifty Rodman smoothbores by the insertion of wrought-iron tubes. Benét recognized, however, that it was only an expedient solution. Guns of full power, he said, must be made of steel. But the country was unable to produce such weapons wholly out of home products. He proposed that the subject receive the careful consideration of Congress. As he saw it, there were two solutions: the establishment of a national foundry, or the encouragement of private enterprise to procure the
 16
 necessary plant and experience.

In the naval appropriations act passed in March of 1883, Congress called for the establishment of the Gun Foundry Board. It was composed of six officers, selected from the Army and the Navy, who were given the requirement to determine the best location for a government foundry ". . . , or what other method, if any, should be adopted for the
 17
 manufacture of heavy ordnance adapted to modern warfare, . . . " The board toured England, France, and Russia to investigate the methods

employed in Europe. It was not the board's intention to ignore Germany; Krupp simply denied permission for an official visit. The report of the board was transmitted to Congress by President Chester A. Arthur
18
in February 1884.

The board drew some conclusions about the status of gun steel production in the United States:

. . . the immense steel works of the United States, from lack of demand for this special material, have not the necessary plant for forging, and are in no condition at present to manufacture steel for cannon in such quantities and in such sizes as are essential for a suitable armament for the country

While the rest of the world has advanced with the progress of the age, the artillery of the United States had made no steps forward. Its present condition of inferiority is only the natural result of such want of action.¹⁹

The perceived inferiority of American artillery was clearly related to the failure to use steel in its construction. The question is where did responsibility for the failure lie? The conclusion must be that, with respect to land ordnance, a large measure of responsibility lay with the Ordnance Department. By 1881, American industry was
20
producing 1,210,285 tons of railroad grade steel annually. It was not until 1883 that the Department began a serious solicitation of American industry for a gun grade of the metal. The response to the solicitation was limited; the capacity simply did not exist. But one enterprise, the Midvale Steel Works, did successfully construct three
21
experimental hoops for heavy artillery, which was evidence that with sufficient inducement American industry could indeed produce the metal. If the Ordnance Department had shaken itself free from its devotion to cast-iron construction before the controversy of 1881, it is quite probable that a national source of gun steel would have been available at an earlier period.

In any event, the Gun Foundry Board recommended the establishment of two government gun factories, one for the Army at Watervliet Arsenal, West Troy, New York, and one for the Navy at the Washington Navy-Yard, District of Columbia. The board's use of the term "factory" rather than "foundry" is significant. They borrowed from the French a concept in which civilian industry produced rough forgings to be machined and assembled in government factories. ²² The French system did not provide for the establishment of government foundries per se, which would have performed the complete manufacture of weapons.

Previously, American guns had been manufactured by contract to civilian firms, although few orders had been let since the Civil War. ²³ The advantage to the government of the establishment of a factory was simply one of economy and efficiency. The board found British and Russian dependence on private enterprise for the production of modern artillery to be costly. ²⁴ But Congress was slow to react to the recommendations of the Gun Foundry Board, and an artillery factory for the Army would not become a reality for several years.

Until 1881, the Department had been following a dead-end path in its attempts to continually upgrade cast-iron heavy guns. Without question, an important corner was turned when Benét solicited gun steel from American industry. Four years later he reported: ". . . experience has proved the entire ability of our steel makers to produce, without too great difficulty, the required metal;" ²⁵

The turn to steel, like the interest in a gun factory, was driven by the perceived needs of heavy artillery. The construction of lighter guns would profit from these advances, as it had from past achievements stimulated by heavy gun requirements. Although the

Department concentrated its efforts on heavy weapons, it did not neglect the development of lighter pieces. In fact, the 1880's was a decade of steady, albeit unspectacular, improvement in mobile artillery.

When the 1870's closed, the Department had begun its first program of improvement in field artillery materiel since the Civil War. On a plan initiated by Crispin, several 3-inch, wrought-iron, muzzle-loading rifles had been cut off at the breech and modified by the addition of a steel, sliding-block mechanism on the Krupp plan, figure 17. In addition, the Department had begun the design of a metal carriage for the improved field pieces.

In July 1881, by general orders, a board was directed to convene in Washington, D.C. ". . . to consider the recent changes in guns, harness and equipments for light batteries, and will recommend any changes from present methods which to their experience and judgment may seem fit." ²⁶ The board was composed of seven artillery officers under the chairmanship of Major John C. Tidball. Upon finishing its work at the end of September, the board drew several conclusions about field artillery materiel. It indorsed the breech-loading modification of wrought-iron field pieces; but it thought that steel designs would be needed in the future, with muzzle velocities not less than 1,600 feet per second. Also, the board recommended the adoption of telescopic sights for field guns and the construction of a carriage that ²⁷ would permit sufficient elevation for curved fire. Benét received the views of the artillerymen and announced in his 1882 report that he had directed the design of a steel, breech-loading field gun and the preparation of a metal carriage for the inspection of a future board. ²⁸

When Benét gave his instructions to the Ordnance Board it was

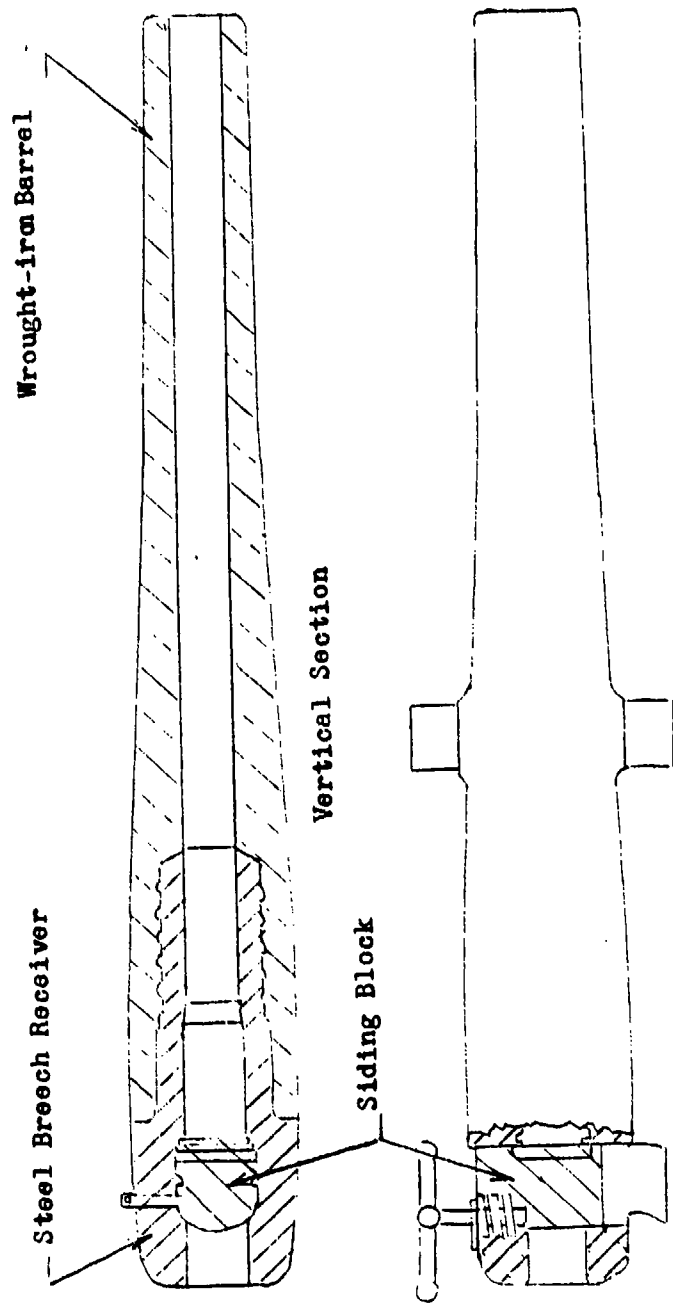

Horizontal Section of Breechblock

FIGURE 17

FIELD GUN MODIFIED WITH SLIDING-BLOCK BREECH

SOURCE: U.S., Congress, House, Report of the Secretary of War, Ex. Doc. No. 1, 46th Cong., 3d sess., 1880, pt. 2, 3:app. 8a, plate 1.

clear that the new weapon would be a departure from the recent attempt to modify the old wrought-iron guns. Not only would the new weapon be steel, in addition, Benet directed that it would have an interrupted-²⁹ screw breech.

There were two basic proven breech designs, known as the "German" and "French" systems. The German, or Krupp system, was introduced in the United States in the 1870's. It worked by the horizontal movement of a wedge through the side of the breech. In the closed position the wedge sealed the bore. The fitting was made tight against gas leaks by a replaceable Broadwell split steel ring, which lay be-³⁰ tween the wedge and the barrel. The designation "French" for the second system is misleading; it was actually American in origin. Benjamin Chambers, a Washington, D.C., mechanic, had patented a slotted-screw breech in 1849. However, it was the French who seized the idea and improved it.³¹ In contrast to the German system which worked from the side, the French breech closed from the rear. The breech was sealed by an interrupted screw, which with a short turn engaged simi-³² larly out threads in the breechblock, figure 18. Gas was sealed by a band of material, primarily asbestos, between two Broadwell rings mounted on the inside face of the breech screw. Under the pressure of the detonation of the propelling charge, the obturator, as the band was called, expanded to prevent the escape of gas.³⁵ Both systems were effective and are still in use today. Benét's new 3.2-inch gun was the first American weapon to be constructed on the French system.

In addition to trying a new breech, Benét directed the Ordnance Board to investigate the advantages of employing built-up rather than single piece construction for the barrel. In his instructions to the

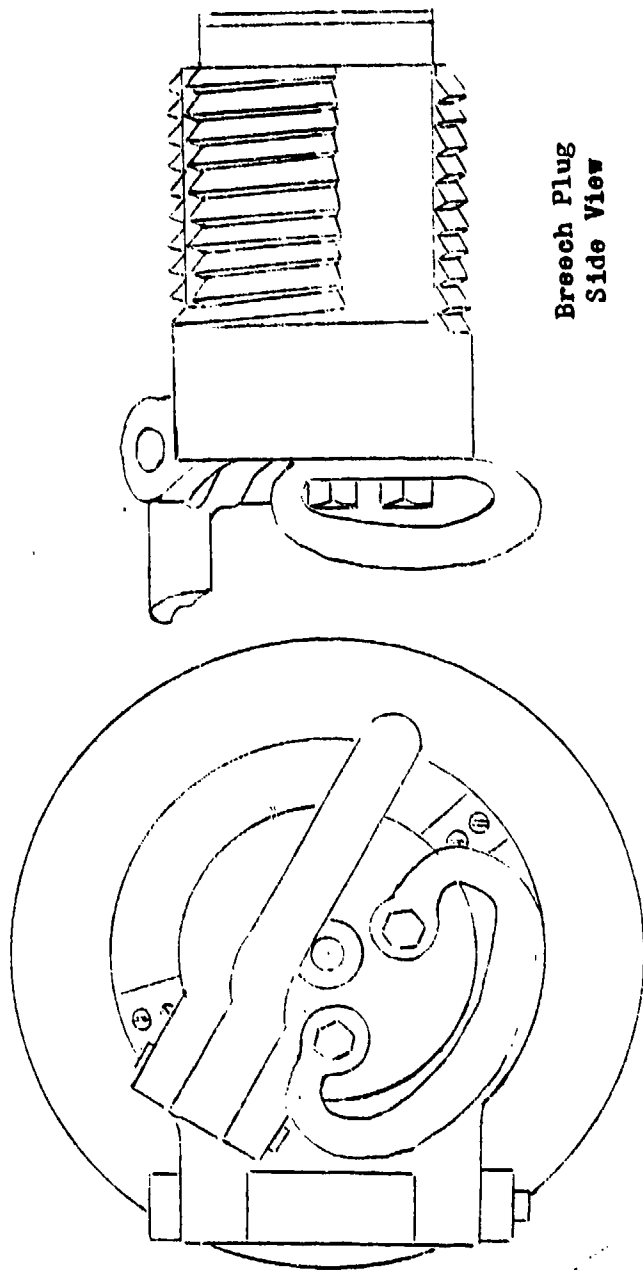

Breech Plug
Side View

Closed Breech
End View

FIGURE 18

INTERRUPTED-SCREW BREECH

SOURCE: U.S., War Department, Annual Report of the Secretary of War for the Year 1884 (Washington, D.C.: Government Printing Office, 1884), 3:app. 33, plate III.

board he noted that modern European field guns were constructed on the built-up principle. Like the "French" breech, the concept of constructing barrels with concentric hoops was an old American idea. Professor Daniel Treadwell (Harvard) had patented a built-up gun in 1855, but he was unable to interest the government in the idea. Almost simultaneously, Sir William Armstrong introduced the concept into his successful system of British artillery. ³⁴ The idea spread in Europe, and to some extent, it was adopted in American guns; for example, the banded Parrotts were a simplistic adoption of the system, as were the converted Rodmans. But it was not until the 1880's that the Ordnance Department began to seriously exploit the strength advantage of complex built-up construction in both light and heavy artillery. Figure 19 is a 3.2-inch gun of built-up design. Compare it with figure 17, the one-piece barrel construction of a wrought-iron rifle.

The Ordnance Board was successful with its design, and the first steel 3.2-inch gun was tested in 1884. Benét was proud of the results which ". . . are deemed extremely favorable as compared with the firing of similar guns in European services." ³⁵ The ordnance designers had managed to achieve a muzzle velocity of 1,629 feet per second, which exceeded the requirement of the Light Artillery Board. The trend toward higher muzzle velocities, hence flatter trajectories, is evident when one compares the capability of the new gun with the 1,215 feet per second characteristic of the wrought-iron piece that it was designed to replace. ³⁶

While the Light Artillery Board wanted a high muzzle velocity, it also wanted a carriage that would permit the delivery of curved fire. The two desires are understandable: improved performance at low

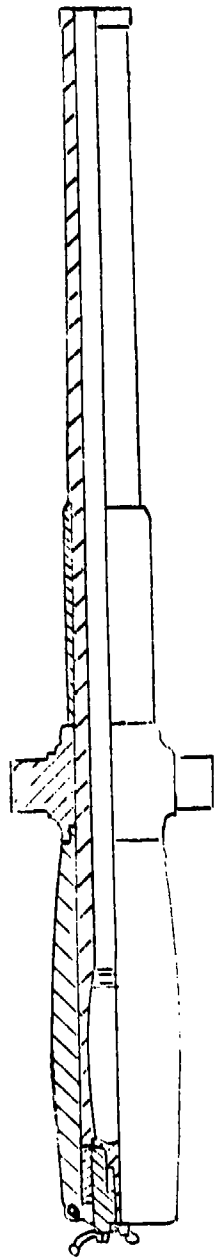

Half Horizontal Section

FIGURE 19

3.2-INCH, BREECH-LOADING, STEEL FIELD GUN

SOURCE: U.S., War Department, Annual Report of the Secretary of War for the Year 1884 (Washington, D.C.: Government Printing Office, 1884), 3:app. 33, plate 1.

NOTE: The gun is of all steel built-up construction.

trajectories, and the ability to deliver curved fire if it was needed. The difficulty was that the state of the art in carriage design made it difficult to accommodate the force of recoil of high velocity artillery at raised elevations. It was not at all clear that one field gun carriage could efficiently satisfy both requirements.

The Department had been working since 1880 on the design of a metal carriage for light artillery. After three years, the Ordnance Board tested one of steel. The carriage featured spring recoil brakes designed by Lieutenant Colonel A. R. Buffington. They were fixed at one end to the axle and at the other end to a wheel, figure 20. The brakes reduced recoil on a hard, flat surface from 26 feet to 8 feet. In addition, the carriage permitted a maximum elevation of 21 degrees. However, it was below the 30 degree capability that had been requested by the Light Artillery Board. The artillerymen's request had to yield to practical considerations. The Department continued its effort to improve the carriage, but the strain caused by the great force of recoil, resulting from the use of heavy charges in the new light guns, complicated the construction problem. When the Department finally began to manufacture carriages for issuance with the new guns, the maximum elevation was still 21 degrees. Even at lower elevations, the force of recoil caused damage to carriage components when the guns were used by troops in the field.

In 1884, word of a new German propellant powder came to America. It was said that German mills were altering the proportions of the common ingredients of black powder--saltpeter, charcoal, and sulfur--to produce a new explosive that provided higher muzzle velocity without an increase in gas pressure. In addition, brown powder, as it was called, produced

FIGURE 20

FIELD CARRIAGE WITH SPRING RECOIL BRAKE

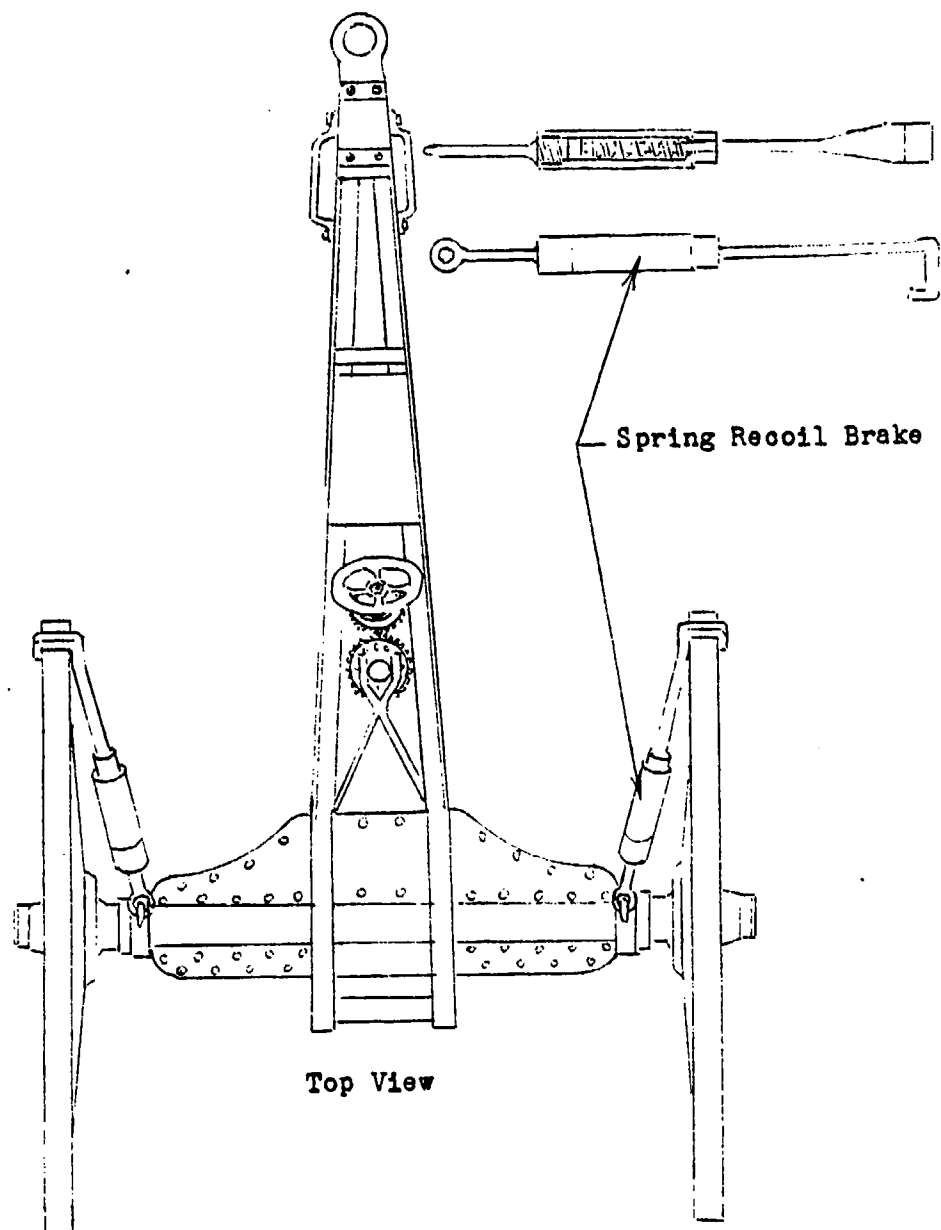

SOURCE: U.S., War Department, Annual Report of the Secretary of War for the Year 1883 (Washington, D.C.: Government Printing Office, 1883), 3:app. 32, plates I, II.

42

less smoke than the black variety. The Ordnance Department quickly secured some of the new powder for trial, tested it in a 12-inch rifle, and provided samples to du Pont. Within a year, the chemical company gave the Department a domestic sample to evaluate. It was a success, and Benét advertised for manufacturer's bids.⁴³ Following Rodman's work with controlled grain size, experts had varied the shapes of granules to achieve still greater efficiency of combustion, but it was not until brown powder was introduced that another major step was taken in propellant design.

It can be said that 1884 was the year of powder; not only did the Department begin the adoption of a new propellant, it also began an attempt to use high explosives in shell construction. High explosives, such as dynamite, held the promise of increasing the effect of artillery ammunition by giving it a more powerful burst. However, high explosives were sensitive to shock, and it was no easy matter to find ways to overcome the hazards of the propelling jar of a gun's detonation.

In 1884, Benét felt reasonably certain that explosive gelatin, a rather stable mixture that included nitroglycerine and guncotton,⁴⁵ could be safely fired from service guns. It was easier said than done. The unmodified gelatin gave erratic results.⁴⁶ Inventors made several attempts to use dynamite itself in shells. One idea offered to the Department is shown in figure 21.

Perhaps the most interesting attempt to use high explosives was the dynamite gun. It relied on compressed air rather than gunpowder to propel shells. In 1884, a 4-inch barrel of a length of 40 feet was under construction at the Delamater Iron Works in New York.⁴⁷ The

FIGURE 21
BRISBEN'S SHELL FOR HIGH EXPLOSIVE

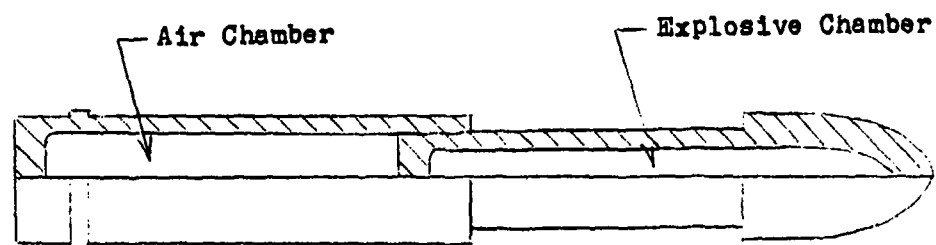

Before Firing
(Half Section)

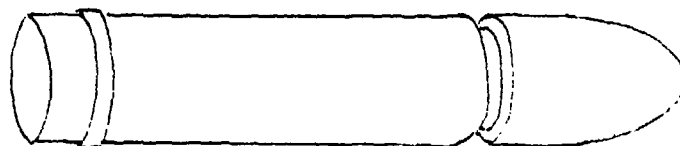

After Firing

SOURCE: U.S., War Department, Annual Report of the Secretary of War for the Year 1887 (Washington, D.C.: Government Printing Office, 1887), 3:app.12, plate I.

NOTE: The air chamber was intended to cushion the shock of propellant discharge. It was one of several ideas considered and rejected by the Department in the search for an effective system for firing high explosives.

Department was interested in the dynamite gun, and efforts at the weapons' perfection would continue for several years; but more efficient solutions to the problem of the delivery of high explosives evolved, and the dynamite gun project died without ever becoming much more than an interesting experiment.

Public criticism by ordnance officers of national policy on weapons development was not a common occurrence; but, in June 1884, Captain Otho E. Michaelis told a New York Times reporter that a national program of development simply did not exist. He said, "Fortunately, under our system of government, state policy is shaped by public opinion, and it is for our intelligent thinkers to make this felt." Since 1881, a series of military boards and congressional committees had looked at various ordnance questions; but as another ordnance officer, Captain Rogers Birnie, said, the reports ". . . contain a vast amount of valuable information . . . which we can only regret has been put to so little practical use, . . ." In effect, there was no coherent national policy on land armament.

To bring order to the armament effort, in 1885 Congress directed the formation of the Board of Fortifications or Other Defenses. The board was to consist of the Secretary of War, two officers each of the Engineers, Ordnance Corps, and Navy, and two civilians. Secretary William C. Endicott chaired the board, which included, among others, Benét himself and Lieutenant Colonel Henry L. Abbot (the engineer officer who commanded the siege train at Petersburg). The board was instructed to review the needs of coast defense. In making its report the board observed:

It is impossible to understand the supineness which has kept the nation quiet--allowing its floating and shore defenses to

become obsolete and effete--without making an effort to keep progress with the age, while other nations, besides constructing powerful navies, have not considered themselves secure without large expenditures for fortifications, including armored forts.⁵²

To correct the deficiency, the board recommended a long-range construction and armament program of a total cost of \$126,377,800. Of that amount, \$70,294,800 was to be spent on armament; the remainder was for the construction of forts. The plan was massive in its extent; it provided for the upgrading of the defenses of twenty-seven ports.⁵³

Not since the work of the 1867 board had there been a comprehensive statement of coast armament requirements. Unlike the recommendations of the earlier board, which had been submerged in the standoff between Dyer and Congress, the work of the Endicott committee initiated a building program that was to run for more than two decades, although the availability of funds would fluctuate.

In fact, after appropriating money in 1885 for armament,⁵⁴ Congress permitted two years to lapse before it provided more. The fortifications appropriation bill for fiscal year 1886-1887 passed the Senate but stalled in the House, Benét complained:

. . . the completion and test of the experimental guns under construction, the further development of powders and explosives, and the alterations of carriages for mounting existing guns have practically ceased, . . .

And not only has the work come to a standstill, . . . , but the personnel of the Department, employed on the work, has been almost entirely discharged.⁵⁵

The situation was no better the next year; Congress again failed to provide appropriations for armament. Benét struggled with the problem in the best way that he could. He reported that,

The Department has been enabled, . . . , by means of the small permanent appropriation accruing from the proceeds of sales of unserviceable and obsolete material, to proceed with the manufacture of one 8-inch B. L. gun, . . . ; of one 10-inch B. L. gun, . . . , and twenty-five 3.2-inch steel field guns.⁵⁶

During the bleak period, Benét also managed to give some attention to the most ignored area of artillery development--siege materiel. In 1885, under instructions from the Department, the Ordnance Board had prepared plans for a 5-inch siege rifle, figure 22, modeled on the successful 3.2-inch gun.⁵⁷ The next year Benet announced that the Ordnance Board had also designed a 7-inch howitzer, figure 22.⁵⁸ Except for a brief start at the design of a 4.5-inch rifle at the end of the 1870's, virtually nothing had been done to improve siege materiel in twenty years. The designs of the 5-inch gun and 7-inch howitzer were late but, in view of past neglect, significant initiatives by the Department.

The trend for several years in European siege materiel had been toward larger weapons. As mentioned previously, railroads permitted the strategic movement of guns of almost unlimited weight. By the mid-1880's, however, another class of artillery materiel had begun to achieve importance in European inventories. These were artillery pieces of larger calibers than were normally found in field batteries. Considered as less mobile than common field artillery, they were classified as guns of position.⁵⁹ The average caliber of such weapons was 3.83-inch. In contrast, the average caliber of field artillery was 3.28-inch, which may not seem like much of a difference, until average gun weights are compared, 941 pounds to 1233 pounds, respectively; and the same is done to average shell weights, 15.9 pounds to 23.1 pounds, respectively.⁶⁰ Lieutenant Alexander Schenck, a literate gunner writing at the Artillery School, observed:

When rifle-pits and other field works, however hastily thrown up, enter as a factor, it has become indispensable to bring to bear as powerful an artillery fire as possible, and at the same time this artillery must possess every essential element of an efficient field

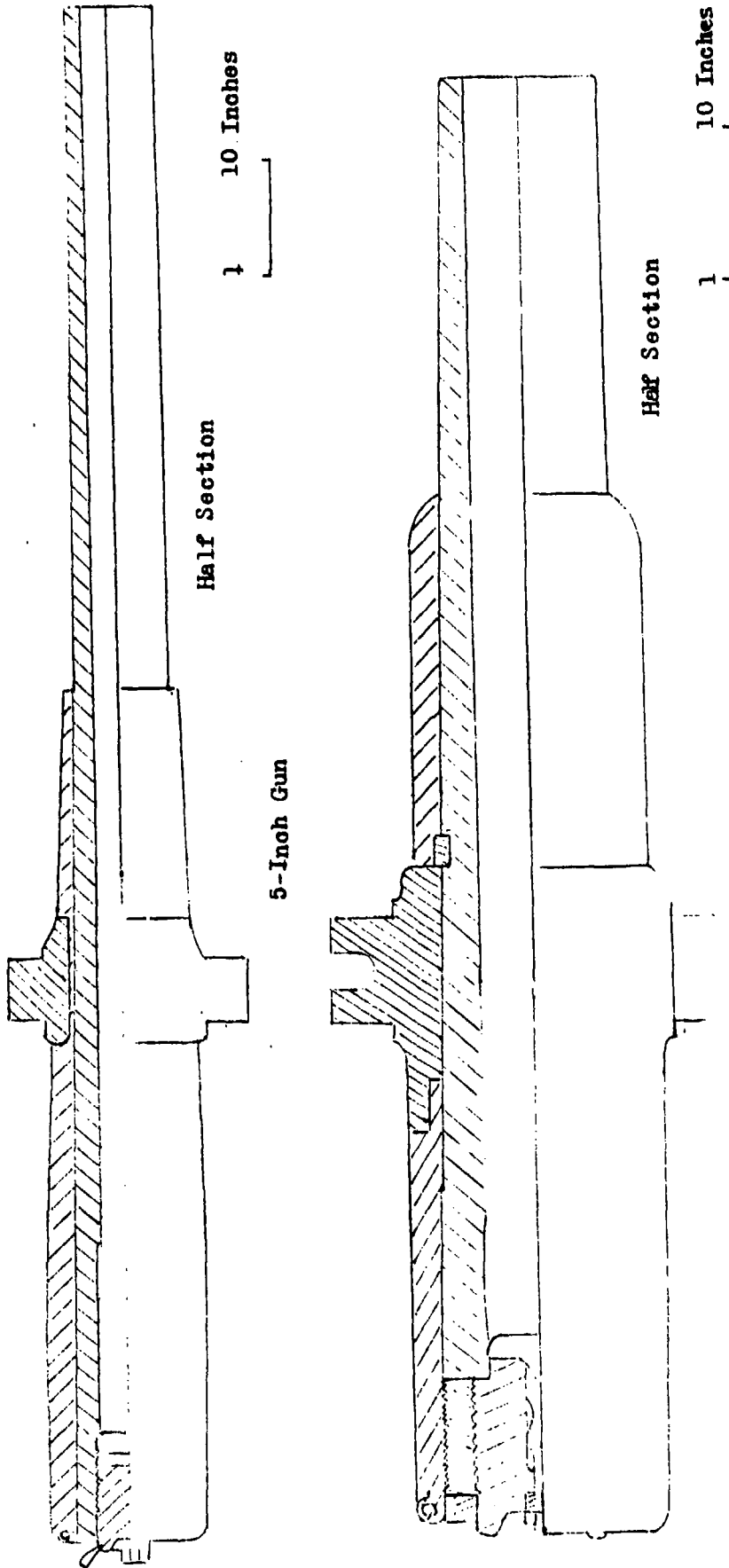

7-Inch Howitzer

FIGURE 22

STEEL, BRECHLOADING, SIEGE MATERIEL

SOURCES: U.S., War Department, Annual Report of the Secretary of War for the Year 1887 (Washington, D.C.: Government Printing Office, 1887), 3:app. 18, plate I; and U.S., War Department, Annual Report of the Secretary of War for the Year 1886 (Washington, D.C.: Government Printing Office, 1886), 3:app. 14, plate 2

artillery; must be with the troops, well to the fore and capable of being brought into action at the earliest possible moment. For those reasons the position gun has become as well established and needful as any other field gun.⁶¹

The idea of adding weight to the fire of the field artillery by increasing the size of some of its weapons is the central feature of Schenck's observation. The heavier weapons were not to be back off of the field, idle in the siege train, but forward with the troops. The proposed deployment was within the confines of the concept of direct fire; "well to the fore" was the traditional position of field artillery; however, the proposed use of heavier weapons was indicative of a conceptual advance within the paradigm. In the American experience, Schenck's observation was still no more than theory; although Benét had advised the Ordnance Board in 1882 that a field gun heavier than the 3.2-inch would be needed at some time in the future,⁶² the Department had not yet undertaken the design of such a weapon.

Siege artillery, of course, was heavier than the field variety. The weapons designed by the Ordnance Department were limited in their weight by the capacity of pontoon bridges. The weight adopted for the new 7-inch howitzer barrel was 3,750 pounds.⁶³ The carriage would eventually weigh another 3,200 pounds.⁶⁴ Ordnance designers worked to construct the most efficient weapon possible within established weight limits. The relationship between the weight of the howitzer and its caliber was important. With the same amount of metal, ordnance designers might have constructed a weapon of greater than 7-inch caliber, but the increased recoil of the more powerful piece would have made it impractical. On the other hand, a 7-inch weapon might have been constructed with less metal, but a reduction in weight would have resulted in

excessive recoil, again making it impractical. The point is that pontoon bridge capacity limited the overall weight of the American howitzer, while the absence of an efficient method of recoil control restricted the caliber. Steel had given strength to gun barrels, permitting the construction of more powerful weapons, but the problem of recoil control in mobile artillery prohibited the full use of the advantage of steel.

In field artillery, the weight of a piece was restricted, not by the capacity of pontoon bridges, but by the lower limit of the drawing power of a six horse team. The harsh demands of campaigning limited the pulling capacity of a field artillery animal to about 850 pounds. Also, gunners generally felt that a team should consist of no more than six horses, which restricted the total load behind the animals to about 5,100 pounds. Teams of more than six horses were difficult to maneuver; and the quick maneuver of artillery was important in the direct-fire concept of employment. Artillerymen saw themselves rushing into battle, deploying hastily within sight of the enemy. As a result, the drawing capacity of a maneuverable six horse team was a perceived restriction on the maximum weight of a field artillery rig. However, the American 3.2-inch gun rig was below this limitation: the barrel weighed 829 pounds; the carriage, 1,166 pounds; and the limber with ammunition, 1,780 pounds, for a total of 3,775 pounds. Even with several mounted cannoneers there was room for some weight increase in American field guns; it was simply up to the Ordnance Department to initiate development.

In 1887, Benét announced that prototypes of the 5-inch siege gun and 7-inch howitzer had been manufactured at Watertown Arsenal and sent

to a proving ground for initial tests. Department engineers had constructed an experimental carriage for the 5-inch gun using wheel brakes designed by Colonel Buffington. The brakes were similar to those used on the 3.2-inch carriage. No special carriage had been constructed for the howitzer. In fact, because of the limited availability of funds and the resulting discharge of mechanics, the Department had been forced to concentrate its efforts on one weapon at a time, first the gun, and then the howitzer. Perhaps the lack of funds prohibited consideration of the development of a heavier field piece, but there is no indication that the Department was intent on proceeding in that direction at the time.

In addition to its failure to appropriate money for armament, Congress had left the question of an Army gun factory unresolved. The Endicott committee had endorsed the earlier recommendation of the Gun Foundry Board that a factory be established. Although the lawmakers had authorized the Navy to begin the construction of such a facility, they failed to do the same for the Army. Finally, in 1887, without explicit congressional approval, the Ordnance Department, with the sanction of the Secretary of War, began to concentrate the necessary machinery to establish a gun factory at Watervliet Arsenal. It was a bold action; Benet simply assumed congressional approval and got away with it.

Actually, by 1887, construction of cannons by the Ordnance Department was no longer a novelty. In 1884, the Department had built an experimental 3.2-inch field gun at the Watertown Arsenal from forgings provided by the Midvale Company. And the following year Benet announced plans to construct twenty-five of the weapons; the

West Point Foundry was to assemble twenty guns, while the Watertown Arsenal was to put five together.⁷⁵ In addition, the 5-inch gun and the 7-inch howitzer had been constructed at Watertown. The gun construction plant at Watertown was something of a "jerry-built" facility. The officer in charge reported, "The machinery needed for the work, some of which was newly purchased, was assembled together in one of the large shops which had formerly been used as a wood worker's shop,

. . . ."⁷⁶ When the Department took action in 1887 to establish a large factory at Watervliet, the effort was more important in its scale than in its novelty. Benét planned to start work immediately on 10-inch and 8-inch, breech-loading, steel guns as well as twenty-five 3.2-inch weapons.⁷⁷ Probably the most important benefit of the new plant at Watervliet was that it gave the Department an efficient facility to produce experimental guns.

Relations with Great Britain deteriorated again in 1887, this time over fishing rights off the Canadian coast. In a dispute over alleged treaty violations, Canadian cruisers began to halt American schooners operating in the fisheries. Tempers flared, and there was talk of a fight. The Detroit News suggested: "When the next war closes,⁷⁸ there should be but one flag floating from the Rio Grande to The Pole." In the House, the Committee on Appropriations received a resolution critical of the state of coast defenses. It began:

. . . the belligerent tone of the Canada press and the announcement that Great Britain will shortly dispatch a fleet of ships to cruise in the vicinity of our northeastern coast line indicate hostility toward the United States, . . .

. . . twenty-seven of our Atlantic, Gulf, and Pacific harbors are absolutely defenseless, [and] . . . are in urgent need of immediate defenses; . . .⁷⁹

In spite of the scattered "saber rattling," Congress failed to

provide appropriations for armament. And although the issue cooled, the continuing lack of money caused Benét, in exasperation, to call upon Congress to take some kind of action. The thrust of his appeal, quite naturally, was toward the needs of coast defense:

It will cost money; but not more than the loss to the cities of New York and Brooklyn from one day's bombardment. All this and more is known to Congress and the country. Reports of boards and committees, reports of official experts, the writings in the public press, individual views, all have kept this important matter before the people, and the responsibility for weal or woe, for success or disaster, must remain with the people. At this time no half measures will do. Congress should decide, and decide at once. Another year ought not to pass without a settled and well-defined policy in regard to the national defense.⁸⁰

Finally, in September 1888, Congress resumed appropriations for heavy armament. At the same time, however, it directed that the money be spent under the supervision of a board to consist of the Commanding General of the Army, and one officer from each of the Corps of Engineers,⁸¹ Ordnance Department, and Artillery. The first officers to hold those respective positions were Major General John M. Schofield, Colonel Henry L. Abbot,⁸² Lieutenant Colonel Alfred Mordecai and Colonel Henry W. Closson. This was not just another entry in the string of congressionally mandated boards that characterized the 1880's; the Board of Ordnance and Fortification, as it was called, was unique in both its permanency and its powers. Although its period of greatest vitality was the 1890's, the board functioned for three decades.

In the initiating legislation, Congress placed the board under the direction of the Secretary of War and gave it the power to provide ". . . regulations for the inspection of guns and materiel at all stages of manufacture, . . ." ⁸³ The charter powers of the board were general to the point of being vague; however, through subsequent legislation, its authority was more clearly defined. Congress tasked the

board to make an annual report of its work. In the first report, the board outlined its method of operation. The Chiefs of Ordnance and Engineers submitted their requests for appropriations through the Secretary of War to Congress, as they had always done; but once the appropriations were made, the Secretary submitted the projects that came under the jurisdiction of the board to that body for its review and recommendations on the allocation of funds. Virtually all questions of armament fell under the jurisdiction of the board. In addition, the board examined a wide range of new inventions, selecting those to be retained for further development.

The significance of the board was that it modified the near total jurisdiction of the Chief of Ordnance over weapons development. For the first time, the Commanding General of the Army, as President of the Board, was given an official role in the choice of armament. Of course, the Chief of Ordnance still enjoyed the selective power of making the original requests for appropriations, but the final allocation of funds was subject to the approval of the board. Equally important, the board became the reviewing agency for new inventions and the judge of systems under development. But one must be careful not to overstate the real power of the board. In effect, power over weapons selection and development was shared by the board and the Ordnance Department: although the board had the responsibilities outlined above, in the final analysis, it was largely dependent on the facilities and technical expertise of the Department.

The establishment of the board certainly did not alter the preoccupation of the Army with coast defense. The 1888 appropriations act initiated the extensive program of fortification recommended by the

Endicott Board. Through the next decade, the interest of the War
 86
 Department in the program would become almost obsessive.

Although the Ordnance Department had made some advances in
 field artillery materiel by 1888, in general, the light batteries suf-
 fered from a lack of attention. The Army Inspector General reported
 that, "Some of the light artillery is still plodding along with the same
 87
 guns they had at the close of the war of the rebellion, "
 (Not all batteries had the new 3.2-inch guns.) Furthermore, he found
 that training was inadequate because of a lack of target practice
 materials and ranges, with the result that some batteries neglected
 88
 firing entirely

In tactics, the situation was equally stagnant. A board to
 revise the tactics of the Infantry, Cavalry, and light artillery was
 convened in Washington, D.C. in February 1888. It was a mixed board
 of eight officers of all three branches under the direction of infantry
 89
 Lieutenant Colonel John C. Bates. The board was convened to consi-
 der a large number of recommendations for new tactics that had accumu-
 lated over a decade. But the meaning of the term "tactics" had not
 changed appreciably since the late 1860's, and the board was primarily
 90
 absorbed in matters of drill. Colonel John Tidball, retired, but an
 artillery proponent in the manner of Henry Hunt, did precipitate a
 debate over the proposed assignment of guns to the level of the divi-
 sion. Tidball thought that they should be consolidated at corps,
 where centralized direction would maximize the advantage of modern
 91
 rifled pieces. Colonel Henry W. Closson, artillery member of the
 Board of Ordnance and Fortification, disagreed with Tidball. He
 recommended the retention of divisional batteries, because ". . . the

association between Artillery and Infantry cannot be too constant or intimate." ⁹² He saw in Tidball's proposal an attempt to separate the field artillery from its traditional close association with the infantry. ⁹³ Closson's comment was a subtle manifestation of the continuing dominance of the direct-fire concept of employment of field artillery. Closson's view's prevailed; drill regulations continued to refer to the use of divisional batteries, particularly when the division was to be "closely engaged." ⁹⁴ Beyond the updating of drill, the board did little to change the field artillery tactics.

CHAPTER VIII

1889-1900: ACCELERATED DEVELOPMENT OF MOBILE ARTILLERY

The year 1889 began a new era in American artillery development. It was a period of acceleration, made possible largely by the availability of armament funds. It was the almost compulsive concern for coast defense that drove expenditures. America was beginning to turn outward, and interest in the demands of seapower rode high. Congress did not exactly throw the doors of the Treasury open to the War Department, but it did respond to requests for appropriations for fortifications with a generosity unknown since the Civil War. Field and siege artillery benefited from the largess; appropriations for their development were buried within the fortification bills. When questioned by Congress about the practice, the Chief of Ordnance replied that until the heavy armament of coast defenses was complete, lighter artillery would be needed to repel invasion.¹ Field and siege weapons were lumped together with the heavier brethren under that magic appellation "coast defense." There should be no mistake, however, about the relative size of the monetary efforts. For instance, for Fiscal Year 1892, the Chief of Ordnance requested \$2,090,000 for the construction of coast weapons,² while asking for only \$186,000 to build field artillery. Nevertheless, the development of mobile artillery was at last receiving rather constant fiscal attention.

In 1889, following the European lead in the development of heavy field artillery, the Chief of Ordnance announced the planned

3
construction of a gun and a mortar of 3.6-inch caliber. Prototypes of the weapons were completed the next year. Benét intended that the 3.6-inch gun would replace the 3.2-inch piece in the light batteries. He felt that the 3.2-inch weapons would be more suitable for the horse artillery of the Cavalry. With a barrel of 1,181 pounds and a carriage of 1,300 pounds,⁴ the new field piece came close to the maximum capability of a six horse team. The 3.6-inch mortar, figure 23, was the first attempt to provide the American field service with a vertical fire capability since the old Coehorn smoothbores had been hauled into the Wilderness in 1864. In contrast to the 17.75 pound shell weight and 1,200 yard range of the Coehorn, the new field mortar could fire 20 pounds of shell or shrapnel to a distance of 3,500 yards.⁵ The mortar carriage permitted a variable elevation of 0 to 60 degrees. In spite of its ponderous appearance, the carriage and gun together weighed only 625 pounds, and ordnance designers hoped to reduce the weight so that the piece might be carried by four men. At the time of the mortar's development, the Department felt that it was the most powerful weapon of its type in any army.⁶

The two new weapons were part of a trend toward heavier calibers and a vertical fire capability for the field service. This trend was the result of some of the perceived lessons of the Russo-Turkish War.⁷ Generally, Europeans were moving in the same direction.⁸

The Ordnance Department did much in 1890 to catch up with the Europeans in artillery materiel: it displayed its first interest in smokeless powder;⁹ it adopted a 7-inch howitzer sight for reverse pointing, figure 24;¹⁰ and, for the first time, it attached a hydraulic recoil buffer to a siege carriage, that of the 5-inch gun, figure 25.¹¹

FIGURE 23
3.6-INCH MORTAR

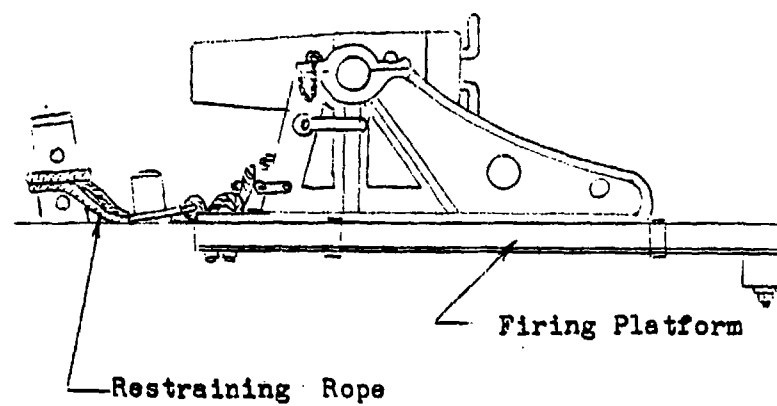

SOURCE: U.S., War Department, Adjutant General's Office,
Artillery Circular I, Series of 1893: Modern Guns and Mortars
(Washington, D.C.: Government Printing Office, 1895), p. 137.

FIGURE 24
SIGHTS FOR THE 7-INCH HOWITZER

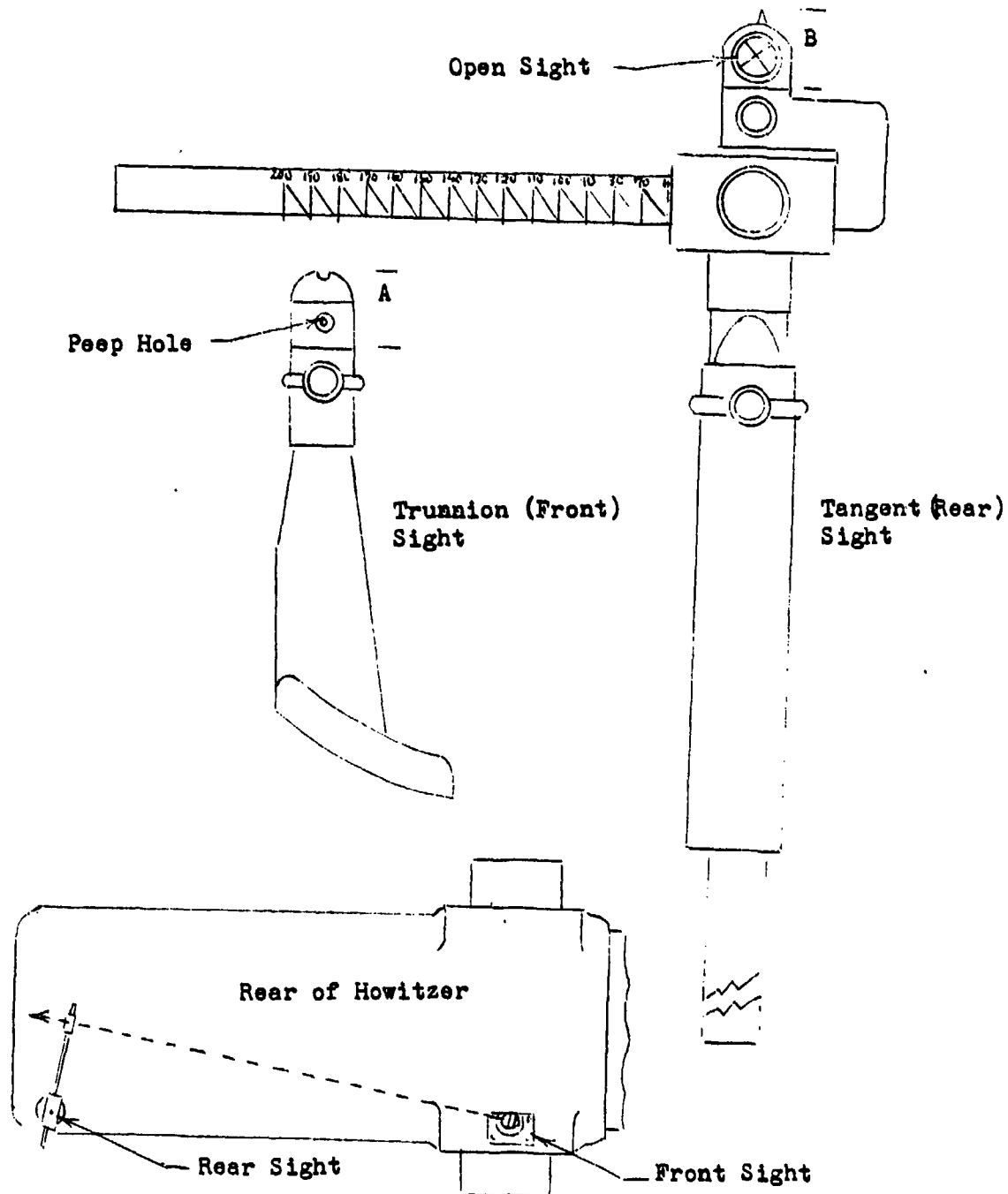

SOURCE: U.S., War Department, Annual Report of the Secretary of War for the Year 1895 (Washington, D.C.: Government Printing Office, 1895), 3:app. 9.

NOTE: Lower sketch shows sights used for reverse laying. By interchanging parts A and B the sights could be used for forward laying.

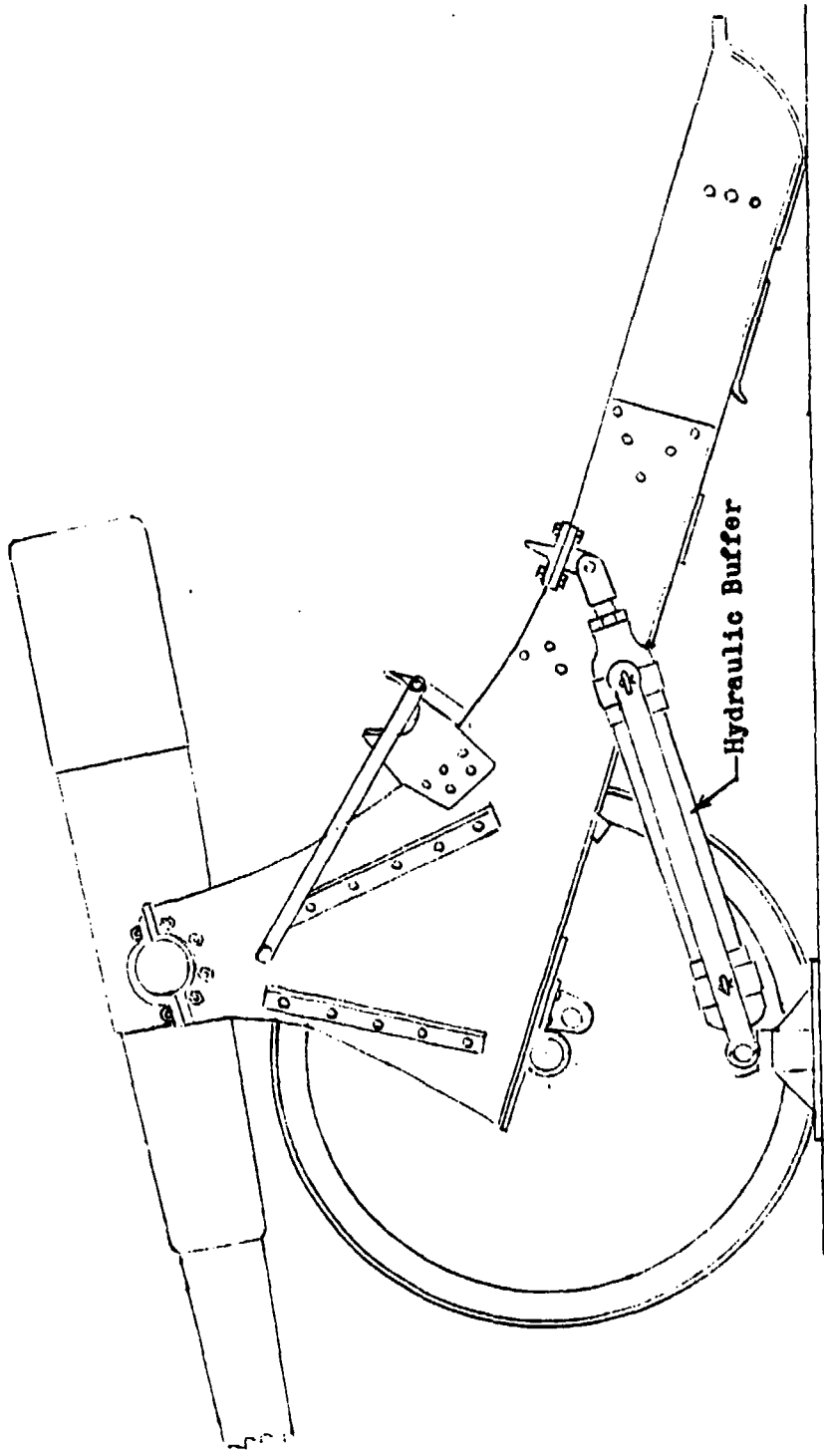

FIGURE 25

5-INCH CARRIAGE WITH HYDRAULIC BUFFER

SOURCE: U.S., War Department, Adjutant General's Office, Artillery Circular I, Series of 1893: Modern Guns and Mortars (Washington, D.C.: Government Printing Office, 1895), p. 145.

The design was essentially the same one developed by the Germans in the 1870's. Within a few years, the Department would also attach recoil cylinders to 7-inch howitzer carriages. American designers used a hydraulic buffer bolted to a firing platform. It was the same plan used for the 5-inch gun. However, following a lead in naval weapons (to be discussed later), they also fixed two recoil cylinders, with return springs, to the upper part of the carriage, ¹² figure 26. With a movement of 6 inches, the upper cylinders absorbed only a portion of the recoil--control was still dependent on the availability of a siege platform. Nevertheless, it was a significant improvement in the design of siege artillery.

The year 1890 also marked the end of Benét's administration of the Ordnance Department. He retired after forty-one years of service. ¹³ The sixteen years that he spent as Chief of Ordnance coincided with a transition period in Department professionalism. When he assumed responsibility for the Department its operations were tainted by the appearance of a parochial mentality; some of its detractors would even say corruption, but perhaps that is too strong a verdict. When Benét relinquished command, the Department operated with greater efficiency, and the old suspicions of prochialism had dissipated, although, as discussed in the next chapter, they were not entirely gone. His successor was Lieutenant Colonel Daniel W. Flagler, a member of the branch ¹⁴ since 1861, and fourth in order of seniority among ordnance officers.

During Flagler's first year in office, the Department continued to investigate the advantages of smokeless powder. Six years earlier, a French chemist, Paul Eugene Vieille, had been the first to develop a ¹⁵ smokeless powder for military use. In 1890, the Department was able

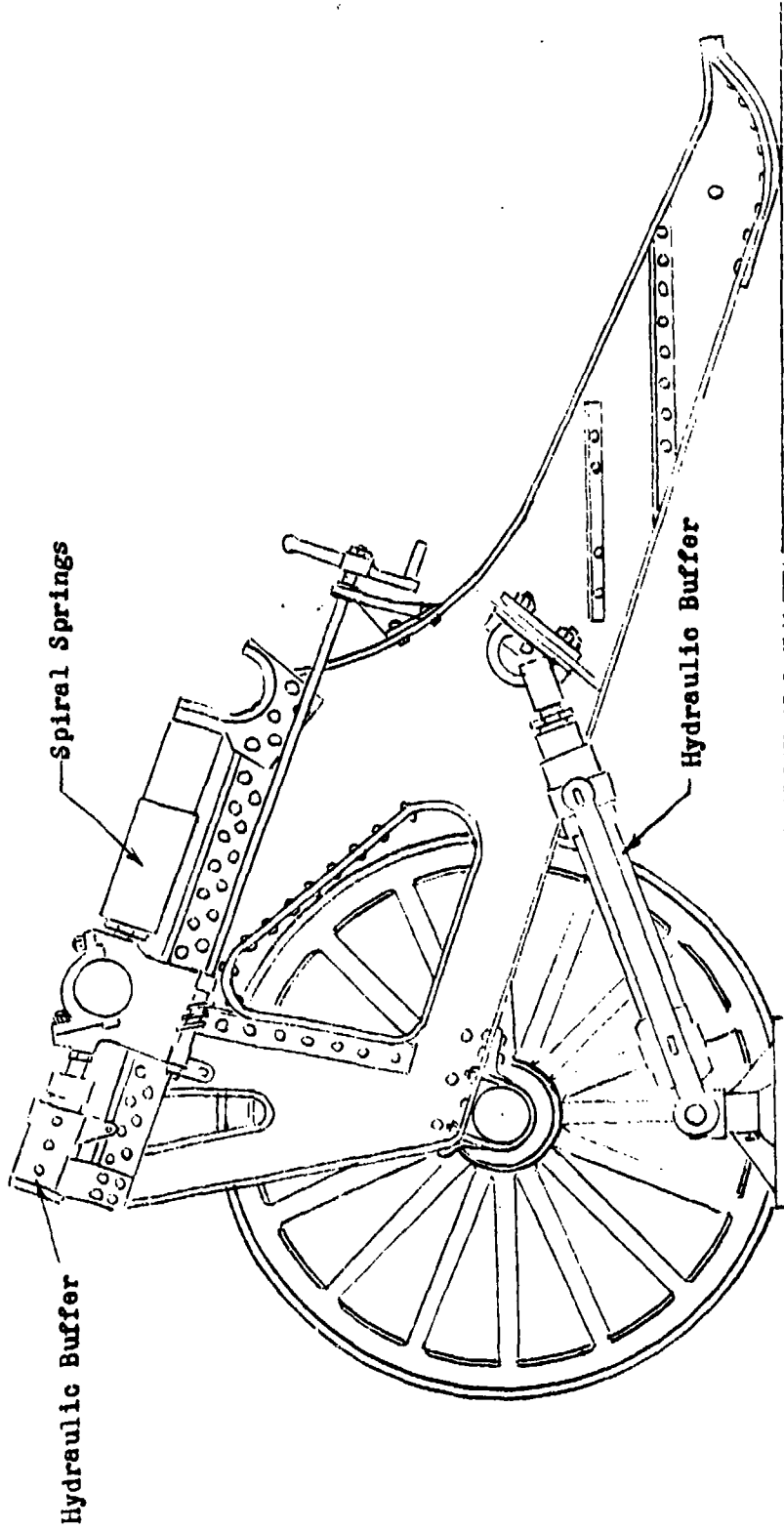

FIGURE 26

7-INCH CARRIAGE WITH RECOIL CYLINDERS

SOURCE: U.S., War Department, Adjutant General's Office, Artillery Circular I, Series of 1893: Modern Guns and Mortars (Washington, D.C.: Government Printing Office, 1895), p. 153.

to secure only a limited amount of the nitrocellulose-base propellant,¹⁶ enough for some small arms tests. A year later, it had procured¹⁷ sufficient quantities from abroad to begin tests with field guns. It was the beginning of a long series of experiments that would last until the Spanish American War. An American source for smokeless powder was available as early as 1892;¹⁸ and although several companies eventually competed to satisfy the strict requirements of the Department, as of 1897 none were successful.¹⁹ There were problems with the new propellant, not the least of which were difficulty in²⁰ preservation and irregularity of explosive pressure. But the advantages were significant; weapons could fire from hidden positions without being exposed by the plume of smoke that followed the discharge of charcoal-base powder. In addition, the burning characteristics of smokeless compounds produced higher velocities, without exceeding the²¹ bore pressures common to brown powder. Nevertheless, unrushed by the attraction of the advantages, for years the Department meticulously examined and rejected the samples submitted to it.

Powders seemed to be the Department's nemesis. The experiments of the 1880's with high explosives did no more than to demonstrate the obvious--that they were sensitive. Of eighteen shells tested, four burst within guns, nine exploded before reaching targets, and only five²² detonated on impact. Soon after it came into being, the Board of Ordnance and Fortification established a committee to investigate high²³ explosives. The committee worked until the end of the decade without²⁴ finding a satisfactory high explosive for service use.

While ordnance designers proceeded with their efforts on material, the training of the field batteries received a moderate boost in 1892

when the War Department established the Cavalry and Light Artillery School at Fort Riley, Kansas. ²⁵ It was the first school for light artillery since the short-lived attempt to establish a program of instruction at Fort Riley in the late 1860's. As the name implies, the school was shared with the Cavalry. The new training facility was primarily oriented on field exercises and the practice of drill; it was not an academic institution like the Artillery School at Fort Monroe. ²⁶ Nevertheless, it was a step forward for the field artillery.

In the same year, the Ordnance Department moved to complete the system of siege armament that it had begun with the design of the 5-inch gun and 7-inch howitzer in the late 1880's. The final weapon in the system was to be a 7-inch mortar, similar in design to the 3.6-inch field mortar. ²⁷

Two years later, the new siege weapon was ready for tests. ²⁸ All of the Department's field and siege pieces constructed since the early 1880's featured an interrupted-screw; it was a successful design. Built-up steel construction was equally successful; it was employed for all of the field and siege weapons except the mortars. They were made of a single piece of forged steel, simply because their low propellant pressures did not require the strength of built-up construction. ²⁹ The collection of field and siege ordnance completed between the 3.2-inch rifle and the 7-inch mortar might be termed an "intermediate system," for the Department was about to be drawn into new considerations in cannon design.

The new thrust was nautical in origin. In the late 1870's, the growing use of small, inexpensive torpedo boats posed a threat to the established navies of the world. If these swift craft could approach to

within 150 yards of a ship, their torpedos threatened its destruction. There was no adequate defense against torpedo boats; large-caliber weapons fired too slowly, and the projectiles of revolving cannons were too light. Consequently, beginning in 1880, the French initiated a search for a suitable defensive gun. The English were not far behind. The result was a series of a single-barreled, breech-loading, rapid-³⁰ fire, cannons.

Rapidity of fire was obtained in three ways; first, metallic case ammunition was used, which reduced loading time; second, the breech was designed to eject the case upon opening; third, recoil was held to a minimum. The latter was achieved in one of two ways: either the gun and mount were fixed rigidly to the deck of the ship, which permitted no backward motion; or a mechanism was used to permit short³¹ recoil before returning the barrel to battery. For instance, by 1887, the Elswick Ordnance Company in England had designed a mount that absorbed recoil with an oil cylinder and then returned the barrel to³² firing position through the force of springs. A rigid system could absorb the recoil of small-caliber weapons, figure 27; but as ordnance designers developed guns of greater size, some mechanical assistance was needed to prevent structural damage to mounts and decks, figure 28. Rapid-fire guns soon outgrew their original role of protection against torpedo boats, and, by 1890, manufacturers were producing a wide variety³³ of calibers of up to 6-inch.

In November 1890, the Board of Ordnance and Fortification had solicited the views of the Chief of Ordnance on the use of rapid-fire guns for coast defense. His reply was favorable. He felt that there was a role for the weapons not only against ships, but also in defense

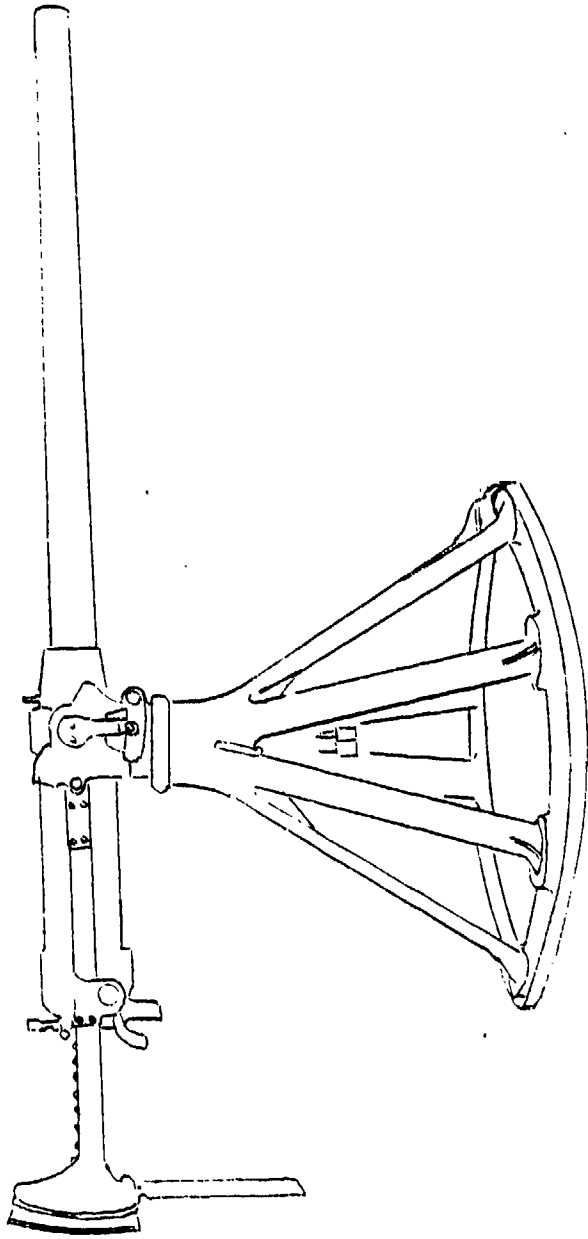

FIGURE 27

DRIGGS-SCHROEDER GUN ON FIXED MOUNT

SOURCE: "The Driggs-Schroeder Rapid-Fire Guns," Army and Navy Journal, 4 July 1891, p. 772.

NOTE: This design was common to the 3- and 6-pounder gun (1.85- and 2.24-inch).

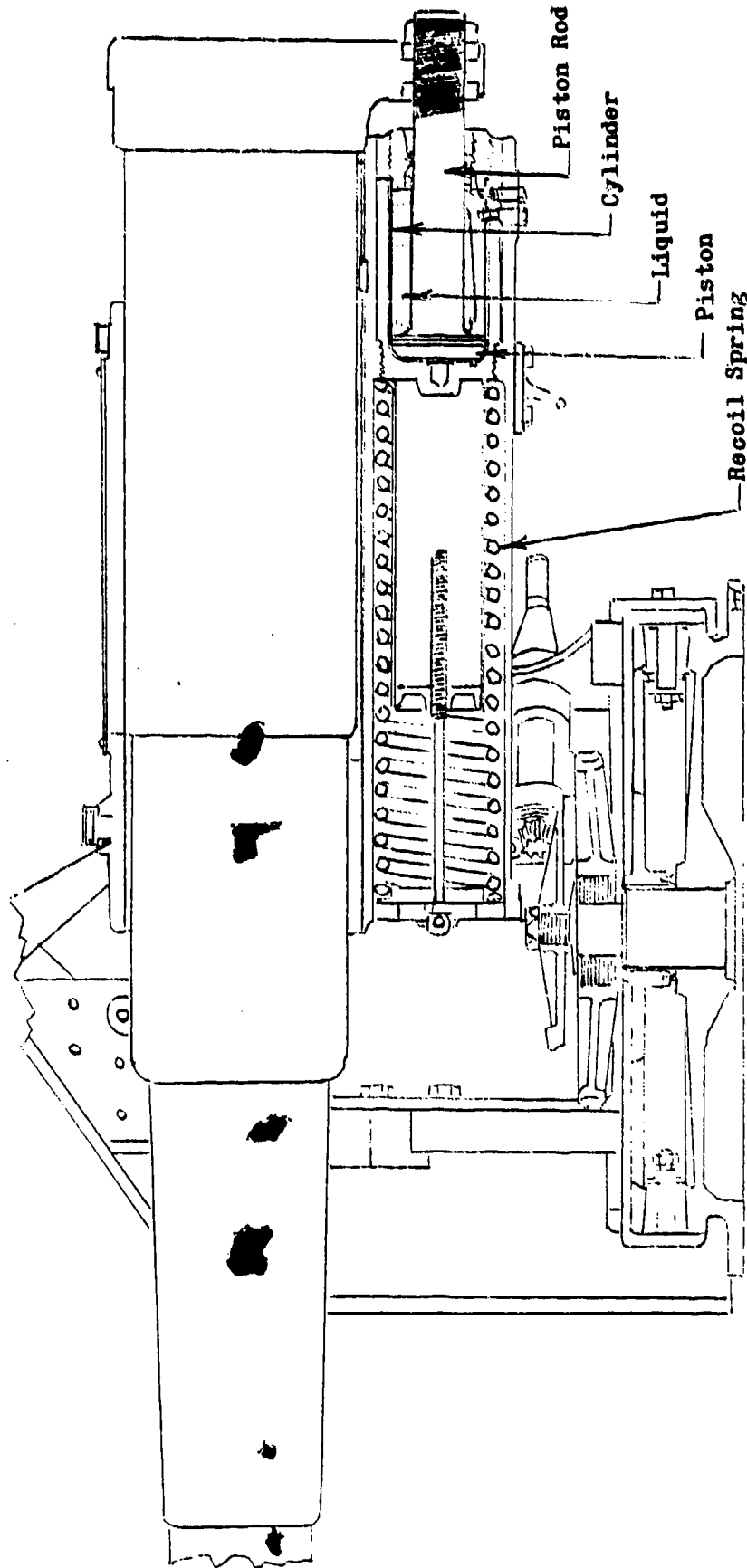

FIGURE 28

ARMSTRONG 4.72-INCH RAPID-FIRE GUN AND MOUNT

SOURCE: U.S., War Department, Annual Report of the Secretary of War for the Year 1896 (Washington, D.C.: Government Printing Office, 1897), 3:app. 21, plate IV.

NOTE: The force of recoil was reduced by the compression of the spring and the displacement of liquid in the hydraulic cylinder. The spring returned the barrel to battery.

of the land approaches to fortifications. He added that some of the weapons might even be mounted on field carriages.³⁴ Soon afterwards, the board authorized the test of three 4.72-inch weapons, the Armstrong, Hotchkiss, and Canet (French).³⁵ The board limited rapid-fire guns³⁶ for the land defense of forts to 6-pounders (about 2.24-inch). The Department already had in its possession two 6-pounders, one had been supplied by Hotchkiss, the other, by the Driggs Ordnance Company, an American firm.³⁷ By 1892, the Department was well on its way toward the adoption of rapid-fire ordnance for coast defense.

Field and siege artillery, however, were a different matter. The light 6-pounder guns, even if mounted on wheeled carriages, were not considered to be field artillery; they were fortification weapons. Lieutenant Edwin St. J. Greble, an American artillery officer, observed in a published essay that there was resistance among some of the members of his branch to the concept of rapid-fire field gun. The objections were principally against the tendency to go to smaller calibers to reduce the problem of recoil, and the additional weight that recoil control devices added to carriages. Although Greble was in favor of the new weapons, he admitted that, ". . . . no really satisfactory rapid-fire gun has ever seen field service" ³⁸

The Ordnance Department was in no rush to develop a rapid-fire field gun. It was, however, interested in metallic case ammunition. The interest of the Department in metal cartridges was practical; it was looking for a better way to keep powder dry; rapidity of fire was a secondary consideration.³⁹ An improved breech mechanism was needed to accommodate metallic cartridges, so as early as 1891, the Department had begun to experiment with a number of designs submitted by American

40

inventors.

In 1895, with some reservation, the Department accepted a Driggs-Schroeder, minimum recoil, 12-pounder gun (2.76-inch) for test. ⁴¹ Engineers at the Driggs Ordnance Company, at Derby, Connecticut, had originally designed the weapon as a landing gun for the Navy. The barrel could be transferred between a deck mount and a field carriage. ⁴² The carriage contained a hydraulic and spring recoil control system. In addition, a spade was fixed to the end of the trail. The force of firing drove the spade into the ground, helping to restrict recoil. However the buried spade made it difficult to move the trail; therefore, to provide for a shifting of aim, the carriage permitted a slight lateral traverse of the barrel. ⁴³ Guns with similar characteristics were in various stages of development in Europe. ⁴⁴ Flagler, the Chief of Ordnance, intended to test the weapon to determine the advantages of a limited recoil carriage for field service. Skepticism is evident, however, in his plan to test simultaneously a carriage fitted simply with a spade ". . . , in order to ascertain whether this simpler type will not prove on the whole quite as efficient as the others, and more suitable for the service." ⁴⁵

Flagler's initial skepticism about rapid-fire field guns yielded to advocacy by 1897. He announced that the Department had designed a new 3-inch model; however, the carriage was still under study. Flagler was unsure of the ultimate design of the carriage, but it seemed to him that a trail spade and recoil cylinder would be included. He felt that recoil control would permit the construction of a light carriage, compensating for the additional weight of the cylinder, and if necessary, a traversing mechanism, although he was worried that the

latter would be too complicated for use by inexperienced militia. He made the point that although the 3-inch projectile would be smaller than the 3.2-inch round, it would be 6 percent more efficient in its effect with shrapnel. The increased efficiency would be the result of a higher velocity and flatter trajectory. And although the Department had not yet decided on a smokeless powder, the gun was designed to use the propellant. In fact, mechanics were chambering the 3.2-inch weapons still under manufacture to permit the use smokeless compounds. The older weapons would have to suffice until ordnance designers completed their plans for the new piece.

It was an interesting phenomenon. The previous thrust in field artillery design toward heavier weapons and a vertical fire capability had been, to some extent, reversed. Benét's assertion of 1889 that the 3.6-inch gun would become the field artillery's principal weapon was only an invalid memorial to the old trend. The "intermediate" system of field, and siege artillery was in the inventory of the Army; but the new ordnance trend was clearly toward the development of light, rapid-firing, flat-trajectory weapons. The passage of time had blurred the lessons of the Russo-Turkish War--lessons that had seemed to guide artillery development at the beginning of the decade. The lingering paradigm of direct fire was challenged but never really discredited by the example of the conflict in 1878. As the lessons faded, the paradigm tended to reassert itself, exploiting technology in its own behalf.

It was not just men of the Ordnance Department who were under the influence of the paradigm, others were similarly affected. The previously cited artilleryman, Lieutenant Grabie, wrote, ". . . there comes a time when disregarding small-arms fire and irrespective of loss,

artillery must come up on the infantry line and stay there." ⁴⁷ He was an advocate of gun shields, something the Department had not yet adopted. With shields and rapid-fire weapons, gunners could ". . . come into action at short range without too much loss, "and. . . gain the ascendancy over their slow-firing long range high-powered opponerts." ⁴⁸ Greble was not alone in his rejection of the idea of placing guns behind cover. Captain Arthur L. Wagner, noted instructor at the United States Infantry and Cavalry School at Fort Leavenworth, wrote in his 1895 edition of Organization and Tactics that,

It has been recommended by respectable authorities that shelter be obtained by withdrawing the guns slightly down the reverse slope of the crest and directing their fire by means of pointing rods either in front or in rear; but the practicability of his measure in action is doubtful.⁴⁹

In his 1896 Handbook for Light Artillery, Lieutenant A. B. Dyer ⁵⁰ cited the use of stakes as a method of aligning guns behind cover; however, the official Drill Regulations for Light Artillery, of the same year, did not address the technique. The official manual did recommend the use of cover--but it was cover over which guns could be aimed. And although the manual states that, "Ordinarily artillery will hold itself beyond the zone of effective infantry fire; . . . [for] close support . . . at decisive moments, . . . it should not hesitate to enter this zone and meet the fire of the enemy's infantry at short ranges (eight hundred yards)" ⁵¹

Those that advocated placing guns behind cover did so because the tactic would protect batteries from observation and fire. The Germans had done some early work with the method of indirect lay, but their military authorities were divided on its merits. The German firing regulations of 1888 stated that indirect laying should be used

when shooting: at long distances; at a target that was not distinctly visible; over a mask; or at guns in a covered position. ⁵² However, Prince Kraft Zu Hohenliche-Ingellingen, a German artillery expert of international fame, commentated that, "this plan may be alright in peace, ⁵³ but in the hurly-burly of battle it will come to grief." In 1897, the Journal of the United States Artillery carried a reprint of a lecture given by Major General Morize Edler von Reichold. He acknowledged the dispute among German officers, even those of the artillery. Von Reichold himself felt that there was a place for indirect lay, but he strongly maintained that it should be used only in exceptional circumstances. He observed that as a practical matter it was never ⁵⁴ employed in peacetime maneuvers.

Captain Wagner witnessed the 1895 Autumn maneuvers in Europe. He was struck by the unusual degree to which the Germans had begun to employ siege artillery in the field; one regiment was allocated to ⁵⁵ each infantry corps. Normally such weapons were found in a siege train. In the American experience, siege artillery was occasionally hauled into the field to defend selected positions, as it was at Malvern Hill in 1862; but siege weapons were not provided with any formal system of field organization.

In fact, even when the Ordnance Department constructed the 3.6-inch mortar for the Artillery, it had not been decided exactly where the new weapon would fit into the field organization. Wagner hypothesized that the mortars would probably be kept separate from the field guns ⁵⁶ and would be retained at the corps level.

The Ordnance Department had designed shrapnel ammunition as well ⁵⁷ as shell for the 3.6-inch mortar. The design effort was evidence of

the perceived importance of shrapnel, because shell alone had long been the traditional ammunition of high-angle weapons. Gunners certainly had not discarded percussion shell; but, referring to the use of shrapnel in field artillery, the 1896 Drill Regulations said, "Made to burst high by means of its time fuze, it can be used against living targets behind cover, against which percussion shell could have but little effect." ⁵⁸ The Drill Regulations was referring to the use of shrapnel in low-trajectory field guns. The many small projectiles released in the air from a shrapnel round simply gave a better pattern of coverage than could be obtained with a ground detonation of a percussion shell filled with old low-power explosives. In fact, the attraction of shrapnel was such that in the early 1890's there was hardly a thought of using anything else with field artillery. As the Board of Ordnance and Fortification remarked, ". . . there is no demand ⁵⁹ for the use of high explosives in shells for field service." The antipersonnel effects of shrapnel captured the imagination of soldiers, with the result that the need for an effective ammunition to destroy field fortifications tended to be ignored. However, the omission made little difference as long as the light gun remained supreme in the field batteries; its shell was too small to hold much of any type of explosive.

A review of the Drill Regulations of 1896 reveals that the perceived employment of field artillery was still much the same as it had been at the end of the American Civil War; however, there were some differences. The 3.6-inch guns were assigned to "heavy" field batteries, a new designation. And, although the United States Army had not adopted a standard gun pit, the manual carried descriptions of European

firing positions. These were excavations that provided some protection for gunners while still permitting them to see and engage the enemy with direct fire. It is interesting that the manual fails to mention the old persistent American concept of an artillery reserve.⁶⁰ Whether or not a reserve would be employed is subject to question. Another official manual, Troops in Campaign, Regulations for the Army of the United States (1892) prescribes that under ordinary circumstances one-fourth to one-third of the field artillery would be organized into a reserve;⁶¹ and Wagner's 1895 edition of Organization and Tactics makes reference to a reserve.⁶² At best it can be said that the reserve was no longer an indisputable feature of American artillery tactics. There had been another subtle change; increased emphasis was given to the concept of the artillery "duel." In attack or defense, the first mission of gunners was to overcome the artillery of the enemy.⁶³ It was an extension of the counterbattery role of the field artillery that had developed during the Civil War, as a result of the inability of gunners to deal with entrenched infantry. The trend was accelerated by the introduction of shrapnel, which made opposing artillery deadly at all ranges against exposed personnel and animals. The vulnerability of gunners and their horses, operating from exposed positions, was not lost on artillerymen. The paradigm of direct fire restricted the use of concealment; therefore efforts at self-protection took the form of the artillery duel--the early destruction of the enemy's guns. All of this, of course, was in the realm of theory; the artillery had not fought a significant action since the Civil War.

The method of fire control had remained essentially unchanged since the war. Regulations called for the commander of a provisional

battalion to designate the target for each battery, based, of course, on the commanding general's plan. The battalion commander was also to designate the rate and order of battery fire. His instructions were to be either shouted to the batteries or carried by messenger. To control the fire of his battery, the captain had to stand to the windward side, so that his vision of the target would not be obscured by the brown powder smoke. Yet, he had to stand close enough for the gunners to hear his commands. If he were lucky, he might have a Weldon field range finder to help him determine the distance to the target. The Board of Ordnance and Fortification had sent two of the experimental devices to the Artillery for evaluation. The guns, however, had no optical sights, although the Ordnance Department was prepared to provide some, for the first time, to the coast artillery.

In fact, significant advances were being made in coast artillery fire control. In 1894, to investigate methods of integrating the fire of coast guns, the Board on Ordnance and Fortification had established the Board on the Regulation of Seacoast Artillery Fire. The board reported that it was devising methods so that every gun in a harbor could be trained on an enemy's ship without any gunner seeing the target. The board prepared a scheme of centralized control, figure 29. Telephonic and telegraphic communications were to tie the system together, allowing commanders to transmit centrally computed data to the guns. Four years after the board began its work, it announced that a sample artillery station at Fort Wadsworth, New York, had been completely equipped.

During the 1890's, implementation of the Endicott program of expanded coast rearmament raised the question of the numerical adequacy

FIGURE 29

PROPOSED SYSTEM OF CENTRALIZED FIRE
CONTROL FOR COAST DEFENSE, 1896.

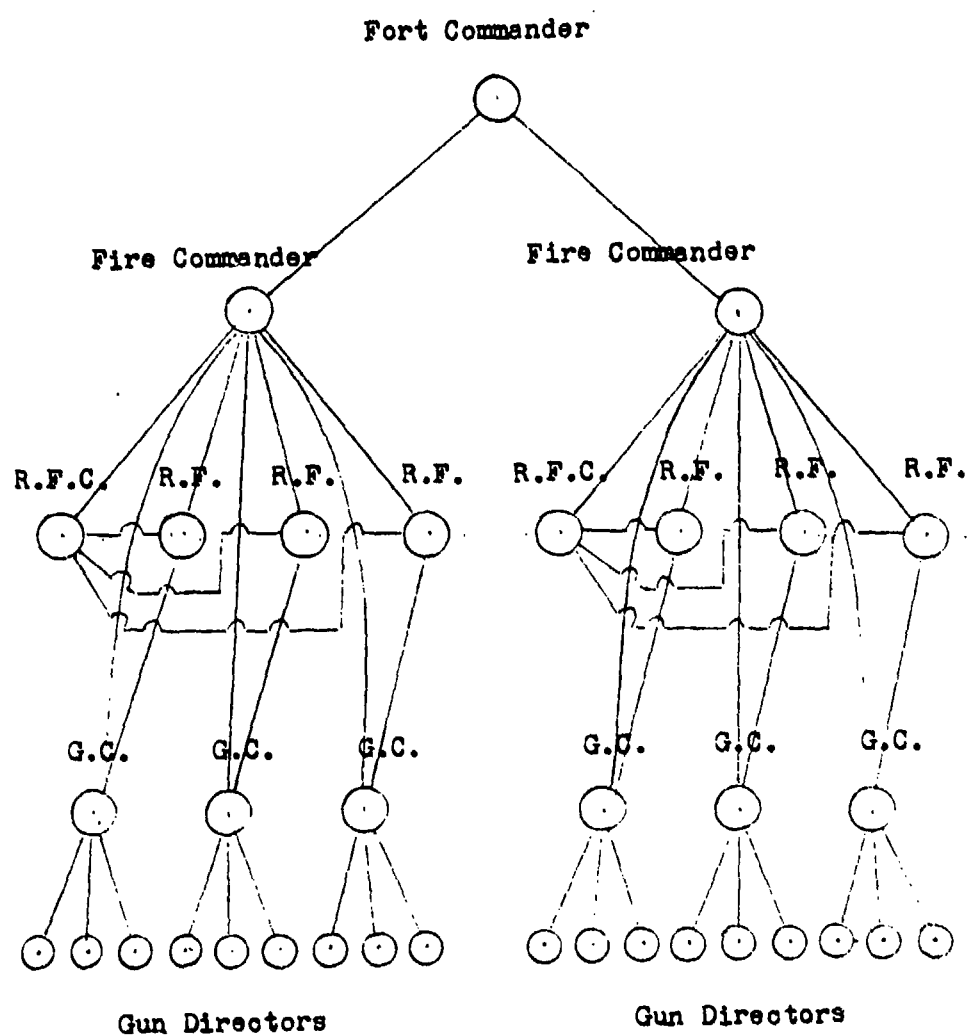

R.F.C.=Range Finder Commander
R.F.=Range Finder Officer
G.C.=Group Commander

SOURCE: U.S., War Department, Sixth Report of the Board of Ordnance and Fortification (Washington, D.C.: Government Printing Office, 1896), p. 47.

of the five existing regiments of artillery. As early as 1889, Major General John M. Schofield, the Commanding General of the Army, recommended in his annual report that the standing artillery force be increased to seven regiments.⁷¹ The additional soldiers were needed simply to care for the new armament during peacetime. The wartime manning requirement would be 85,000 men, most of whom would have to come from the militia,--the entire Regular Army contained only 27,759 personnel in 1889.⁷² Schofield's recommendation was one of several similar proposals that would come out of the War Department over the next few years, but the issue remained unresolved.⁷³ The Army and Navy Journal placed the blame for the delay on Populistic hostility to a standing army in the Senate and an economy minded Speaker in the House.⁷⁴ In the fall of 1897, to avoid an increase in the total strength of the Army, Secretary of War Russel A. Alger was reported to be considering a reduction in the Infantry, in order to provide the necessary manpower for additional artillery units. He saw occupation of the coast batteries as the primary responsibility of the Army, particularly in view of the greatly reduced Indian threat.⁷⁵ At the time, the Army contained ten regiments of cavalry and twenty-five regiments of infantry.⁷⁶ The Infantry was spared a reduction. On 22 February 1898, seven days after the sinking of the Maine, the Senate passed a bill increasing the Artillery by two regiments; and the House approved the act a few days later. The bill provided that, ". . . two batteries of each regiment may, in the discretion of the President, be organized as field artillery, . . ." ⁷⁷ Once again, the field artillery profited from the attention given to coast defense.

Events overtook the planned expansion. On 19 April, Congress

authorized the President to use the land and naval forces of the United States to drive the Spanish from Cuba.⁷⁸ During the subsequent national spasm of mobilization, the ten existing light batteries assembled at Chickamauga Park, Georgia. In May, they moved to Tampa, Florida, forming a provisional brigade under Brigadier General Wallace F. Randolph.⁷⁹ The Ordnance Department called in the 3.2-inch guns that had been distributed to the States and various military schools, with the intention of raising the armament of each light battery by two weapons, to a wartime footing of six field guns. However, the extra weapons failed to arrive before embarkation.⁸⁰ The same is true for the 3.6-inch materiel; the Department had twenty-two of these guns available for issue, but their caissons were not ready. The Department hurriedly sent what siege materiel it could gather to Tampa, to include 5-inch guns and 7-inch howitzers, as well as a number of 3.6-inch field mortars.⁸¹ Since there was no standing organization for a siege train, the Commanding General of the Army, Nelson Miles, ordered that one be formed at the Florida city.⁸²

There was insufficient room on the transport ships for all of the light batteries; consequently, four were chosen by lot to accompany the newly formed V Corps as it sailed for Cuba.⁸³ In addition, General William R. Shafter, the expeditionary force commander, took with him two siege batteries, containing four guns, four howitzers, and several field mortars.⁸⁴

The action in Cuba was centered on the capture of Santiago. Shafter's plan was to assault on 1 July, first on the right at El Caney with part of his force, and then on the left at San Juan Heights with the remainder.⁸⁵ The four batteries of field artillery were organized

into a provisional battalion under Major John W. Dillenback. Initially one battery was allocated to each attack; the remaining two were held in reserve. It was a serious division of combat strength for the already small artillery force.

The reputation of the field artillery did not fare well at Santiago. The fire of Captain Allyn Capron's single battery at El Caney, delivered at a range of 2,300 yards, was poorly directed and dispersed. It was not until late in the attack, when the artillery finally concentrated its fire on a stone fort, that it provided any assistance to the infantry. In the assault on San Juan Heights, Captain George S. Grimes' battery fired for three-quarters of an hour from a long distance and then ceased, apparently on orders from a higher authority. As a result, the infantry attack proceeded without artillery support until the reserve batteries of Captains Charles D. Parkhurst and Clermont L. Best were ordered forward. All three batteries then fired from a long distance until Best displaced forward to the infantry line. As soon as it came into action, Best's battery drew such a fusillade of rifle and artillery fire that it was forced to withdraw to its former position. Nevertheless, by nightfall, the corps had secured the objectives at both San Juan Heights and El Caney. The three batteries that had supported the attack on the left were then ordered to San Juan Hill, where the gunners sweated to dig shallow firing pits in the rocky soil. The Spanish trenches were only 500 yards away; and at daybreak, Spanish rifle and artillery fire drove the American gunners to the shelter of nearby trenches. Captain Parkhurst was wounded in the action. The situation was somewhat restored, and the gunners were back at their pieces when they received the order to

withdraw. By noon on the 2d, the three batteries from San Juan Heights were joined by Capron's battery from El Caney at a location well behind the lines. Shafter meanwhile moved to encircle the Spanish inner defenses around Santiago. The batteries of Capron and Lieutenant Ernest Hinds, who had replaced Parkhurst, took positions in the trenches on the right of the line. On the left, the batteries of Grimes and Best were placed too far to the rear to render effective support, but the action on the 2d had shown that forward positions in that zone were untenable. Shafter's investment of Santiago was followed by several days of truce, and exchange of fire on the 10th and 11th, and capitulation by the Spanish on the 14th. On the 6th, eight 3.6-inch field mortars had been brought up from the landing at Daiquiri. Their total participation in the battle was the firing of a few shrapnel rounds on the 10th. Two additional 3.2-inch batteries landed in Cuba just before the surrender; but they failed to see action. The capitulation at Santiago ended the major land action of the Spanish-American War. Fairly or not, the field artillery was to come under much criticism for its performance.

Arthur Wagner, who was present on the field, was in the forefront of the critics. He wrote in a report of the battle: "Much disappointment was felt throughout the Army at the inefficiency of our artillery;" About the attack at El Caney he said, ". . . the artillery preparation for the attack was feeble, and the position had to be carried by the infantry with very little assistance from its 'indispensable companion.'" His observation was the same for the assault at San Juan Hill. He was particularly critical of the rearward positioning of the two batteries on the left, in the latter phase

phase of the campaign. He wrote:

The average infantry soldier, . . . , understands little about the science of gunnery, and to his mind the position of the artillery so far to the rear was merely an indication of timidity. Rather than to remain where they were, it would have been better for the batteries to advance to the infantry trenches, . . . , for the infantry would then have felt, at least, the encouragement that is always given by the close and vigorous co-operation of the artillery.⁹¹

Wagner's observations were shared by others; and the resulting criticism of the field batteries sparked a lively series of letters from sensitive artillerymen to the editor of the Army and Navy Journal.⁹²

There is not much to be said about the employment of field artillery in the other ground campaigns of the war, Puerto Rico and the Philippines. In neither case did Spanish forces offer serious resistance.⁹³

The Santiago campaign was purely a manifestation of the direct-fire concept of employment of artillery. The use of the artillery indicates that not much had been learned during the years of the Indian wars, and that perhaps something had been lost. In essence, the guns were employed by battery. The provisional battalion was an organization in name only. It was much the same way that batteries had been used in the Mexican War. The 3.2-inch guns were capable of long-range fire, but without mass and effective control, it was of little use to the infantry. When guns were positioned forward, cannoners were cut down by Spanish fire. The artillerymen of the Grand Old Army could have forecast that. Yet this was the employment that was expected of the field batteries. The heavy artillery was never used, and the 3.6-inch mortars fired only a few rounds of shrapnel. In the manner of the past, the siege train was left behind. Wagner reported that only two siege guns were even taken off of the transports at the landing at

94

Daiquiri. Of course, if the Cuban campaign had lasted longer, the Army might have improved its method of artillery employment.

One serious materiel deficiency was the lack of smokeless powder--serious primarily because the Spaniards used the new propellant. Spanish guns were difficult to see, while American pieces put out clouds of smoke, marking themselves as a target and obscuring the

95

vision of gunners. With some justification, artillerymen--a recovered Captain Parkhurst for one--laid the blame on the Ordnance Department.

96

At the outbreak of the war, the Department had hurried to provide the artillery with smokeless powder for field, and siege weapons, but the first shipment arrived at Tampa nine days after the Shafter expedition had sailed. The batteries had to fight with the black powder cartridges that they carried with them; there was no ammunition resupply in the

97

field. After the war, charges of War Department supply and medical mismanagement caused President William McKinley to appoint an investigatory commission. In its investigation of the staff agencies, the Dodge Commission found that, ". . . the Ordnance Department was untiring in its work both before and during the war, and that every effort was made by its officers to properly arm and equip the troops." It was an official vindication, but it did not satisfy all of the detractors of the Department.

98

The war with Spain had been over for little more than a year when fighting broke out in South Africa. An ill-disciplined force of Boer irregulars embarrassed the British Army for two and half years. The Boers had a small quantity of German and French artillery. It was reported that their heaviest guns were 15-centimeter (6-inch) pieces. In addition, they had a few 12-centimeter (4.7-inch) howitzers.

Both types of heavy artillery were said to fire melinite, a high explosive. The Boers also used several European field pieces, to include some quick-firers constructed by Maxim-Nordenfeldt. The British carried a siege train into the field, which contained as its main armament 6-inch howitzers and guns of 5- and 4-inch. Like the Boers, the British had high explosive shells for their heavy artillery. The British ammunition was filled with lyddite.⁹⁹ The British field batteries were equipped with 3-inch guns and 5-inch howitzers. The field guns fired only shrapnel, but the howitzers used both shrapnel and high explosive shell.¹⁰⁰ The difficulty with the reports on the war that reached the United States is that they reflected a broad range of opinion.

In general, the British tended to mass their weapons, while the Boers employed their pieces individually or in pairs and sniped with long-range fires.¹⁰¹ The Boer artillery commander was not much impressed by the guns of either side. He remarked in a letter to a German publication:

To about 1000 shells about 12 men were killed, . . . Our Boer artillery was by no means as successful as I had anticipated before the war The English must have suffered heavy losses, but I know that I, with my artillery, had only a slight share in it, The riflemen disabled in 10 minutes 10 times more than our artillery did sometimes in 10 hours. Artillery in defense does not seem to be destined to play a brilliant part, and as regards the attack, its use consists chiefly in intimidating the enemy so that the attacking body can advance under its protection.¹⁰²

The Boer artillery commander had no monopoly on uncertainty about contemporary artillery. A correspondent with British troops reported:

There seems no sense in the artillery formation in batteries In the latter part of the campaign, . . . they have been split up into sections when thought necessary, but not very often. Yet I have never seen a battle yet where the regular battery formation seemed to serve any useful purpose The individual gun can accomplish vastly more . . .¹⁰³

In spite of the use of high explosives and artillery in a wide variety of calibers, the hit and run tactics of the Boers made the conflict an aberration, a colonial war, worthy of curiosity, but nothing more. The reaction in America to the artillery lessons of the war is well summed up in a comment by Captain Oliver L. Spaulding. In one of his lectures published at the Infantry and Cavalry School, Spaulding said, "The deductions drawn from the Boer war, . . . , are of but slight value to the artillerist, on account of the very special and peculiar circumstances of the fighting." ¹⁰⁴ No lessons of substance fell to the United States Army, at least none that caused a change of priorities.

The passing of the 1890's ended nearly a generation of peace for the western powers. However, the two wars that closed the period held no lessons that would make any difference in the American concept of artillery support for the maneuver army. The Boer War was largely dismissed as a peculiar event, and the Spanish-American conflict was of such short duration that it barely exercised the direct-fire paradigm. If anything, the latter conflict confirmed the same limitations of the field batteries that were apparent at the end of the Civil War. If the campaign in Cuba had lasted longer, and if the artillery had been better handled, the result might have been different. But any significant lessons that might have arisen from the short conflict, were submerged by the success of the easy victory.

CHAPTER IX

1901-1904: A TECHNOLOGICAL THRUST WITHIN THE DIRECT FIRE PARADIGM

The field artillery certainly gained no new importance as a result of the Spanish-American War. In fact, the coast artillery, which had not fired a shot at the enemy, emerged from the war with its greater relative importance entirely intact. Technology, however, would soon force an unprecedented amount of attention on the development of field artillery materiel.

After the war, the momentum for an increase in the coast artillery resumed. Congress authorized two additional batteries of coast guns for each of the seven artillery regiments.¹ To some extent, Army expansion had been desensitized as a political issue. In 1900, a Presidential election year, the Army and Navy Journal, with some cynicism, carried an observation, attributed to the New York "Press" that, "Nowhere in his canvass has the Democratic candidate expressed the fear that seacoast artillery is to be used to 'shoot the workingman down.'²"

Although the coast batteries had again been increased, artillerymen were dissatisfied with the organization of their arm. In general, they saw the administrative regiment as an anachronism unsuited to the organizational requirements of harbor defense. Some seaports required only a few batteries, while the defense of others demanded more. The regimental organization, with a set number of batteries, was somewhat

inflexible. What most artillerymen wanted was a corps structure with no standard echelon above the battery. This would permit the grouping of the batteries in each harbor under the command of an officer of appropriate rank. In addition to organizational efficiency, artillerymen saw another advantage to the proposed change: it would increase³ opportunities for promotion. In the enthusiasm for the corps organization, no thought was given to the particular needs of the field batteries.

Secretary of War Elihu Root agreed with the proposed change. He felt that the time had come to appoint a Chief of Artillery, a position inherent in a corps organization. It was Root's opinion that the Artillery needed a directing head. He felt that the "specialized and scientific" nature of modern ordnance required that one person have the responsibility of insuring that the officers and men of the branch were properly trained.⁴ Root was a dynamic force for change in the Army; his support for the corps concept would do much to secure its authorization by Congress.

In 1900, Root submitted legislation to the lawmakers to increase⁵ and reorganize the Artillery. The campaign to change the Artillery had its own rationale, but it was also part of a broader movement to keep the entire Army above its prewar level. Under the provisions of the Act of 2 March 1899, on 30 June 1901, the Army would revert from its expanded wartime strength--a strength that had swelled with volunteers to a height of 209,714 in 1898--down to 31,472. Secretary Root made an appeal for a larger standing force, and in February 1901, Congress set the ceiling of the Army at 88,619. The act added 5 regiments to both the Infantry and the Cavalry, raising the former to

25 and the latter to 15. The same act disbanded the seven regiments of artillery and established the Artillery Corps. The coast artillery was allotted 126 companies, an increase of 42; the field artillery was fixed at 30 batteries, an increase of 16.⁶ In Root's scheme of reorganization, the Artillery Corps would, in effect, consist of two branches, coast and field. The latter would contain both field and siege weapons.⁷ The concept of a field branch, however, was nearly meaningless as an organizational reform; it was simply a designation for a collection of 30 separate batteries. The primary purpose of the artillery reorganization of 1901 was to increase the efficiency of coast defense.

Root, however, had a second reason behind his push for a corps organization. He wanted a Chief of Artillery to represent branch interests in disputes with the Ordnance Department over materiel.⁸ When Root took office in the summer of 1899, he found that relations between the Department ". . . and the officers of the artillery had become strained almost to the extent of a chronic controversy."⁹ In addition, after several years of cooperation, "The same was true of the Ordnance Department and the Board of Ordnance and Fortification. Practically everything the one proposed the other opposed."¹⁰ A clash of personalities threatened to disrupt the acquisition process.

The difficulty surfaced in October 1898, when the board, under the presidency of the Commanding General of the Army, Nelson Miles, recommended that it be given the authority to spend money for the construction and testing of weapons. Previously, the board had selected weapons for tests and recommended the allocation of experimental funds from its annual appropriation, subject to the final approval of the

Secretary of War; but never before had it attempted to become involved in the actual making of contracts and the disbursement of money; such authority had always resided with the test agency, the Ordnance Department. As could be expected, the ordnance member of the board, Lieutenant Colonel Frank H. Phipps voted against the recommendation.¹¹ The Secretary of War did not change the disbursement procedures; nevertheless, the incident marked the beginning of a growing controversy between the Department and the board.

It was not Daniel Flagler, however, but A. R. Buffington who would head the Department during the period of controversy. Flagler had died in office, and Buffington was appointed to replace him. Buffington was commissioned in the Ordnance Corps at the beginning of the Civil War. He did much work on field gun carriage construction during the 1880's, but his most notable achievement was his collaboration with another ordnance officer, William Crozier, in the design of the Buffington-Crozier disappearing carriage for coast artillery. He was a colonel when Flagler had been elevated from a rank below him to the position of chief in 1890. Upon resuming the responsibilities of Chief of Ordnance, Buffington received the stars of a brigadier general.¹²

In August, Buffington cautioned the new Secretary of War, Elihu Root, about a possible conflict of interest should the Department purchase the Lewis Range Finder. The device was a successful coast artillery fire control instrument developed by Lieutenant Isaac N. Lewis, the recorder of the Board of Ordnance and Fortification. Buffington cited a federal statute of 1893 that prohibited the purchase of the device if Lewis was a member of the evaluating board. The board,

under Miles, defended Lewis with the explanation that, as the recorder,
13
he was not a voting member.

The significance of the incident, however, was more involved. Lewis was an artillery activist. About the same time that Buffington cautioned Root on the possible conflict of interest, Lewis submitted a report to the Secretary critical of the lack of a modern mountain gun in the Philippines. Without consulting the Department, Root ordered a dozen Vickers-Maxim mountain guns for use against the Filipino
14
jungle insurrectionists. It was an unusual step for a junior officer to take his complaint directly to the Secretary of War; the action was bound to create resentment in the Ordnance Department.

The feud heated in October when Miles wrote to the Senate Subcommittee on Fortifications and Ordnance, condemning disappearing carriages. He observed that a large portion of the nation's coast artillery was being mounted on the carriages; yet, he asserted, they were complex and prone to mechanical breakdown. As proof of their inadequacy he pointed out that no European nation had adopted the devices. In the interest of fairness, Root permitted Buffington to endorse a copy of the letter, so that the subcommittee might have "all of the facts." Buffington wrote a reply that understandably refuted Miles'
15
charges of inadequacy. Hostility between the Board of Ordnance and Fortification and the Department was now in the open, and Buffington
16
lost no time in taking the ordnance seat on the board himself.

The situation escalated in April 1900 when Lewis, recently promoted to captain, complained to a Senate subcommittee on appropriations about the smokeless powder situation in the Spanish-American War. He was critical of the failure of the Department to provide the

propellant before the outbreak of the conflict. In addition, he passed on rumors from the field that the Department compounded its negligence by filling shells bound for the Puerto Rican expedition with smokeless propellant rather than a bursting charge. Lewis related that guns using brown powder propellant and smokeless shells had marked their own positions but were unable to sense their fire on the enemy. Lewis' testimony appeared in the New York Tribune, which did nothing to soothe the feelings of the Department. Ordnance records failed to substantiate the allegations that smokeless shells were taken to Puerto Rico; they did, however, show that the propellant had been loaded in ammunition sent to Francisco for use at Manila. ¹⁷ The Department was still testing high explosives during the war; the resort to smokeless powder as a shell filler was an experimental attempt at a substitute.

Lewis was an advocate of high explosives, and he had urged the adoption of thorite. It was reported in the press that it was Lewis' recommendation, supported by Miles, that caused Secretary Root to take action to have the explosive sent to the Philippines for trial. ¹⁸ The Department loaded a number of 3.2-inch shells with a mixture of thorite and black powder for use in the archipelago. Although the mixture was superior to black powder alone, it deteriorated over time. As a result, the Department continued its long string of experiments with two other explosives that looked promising, picric acid and Rendrock Company's ¹⁹ No. 400 powder.

Following closely behind Lewis' attacks on the Department, Miles took the unusual step, in August, of writing to the Secretary of War to strongly recommend that he stop Buffington from pursuing his plans to to into production on the new 3-inch gun. Miles was particularly

annoyed that the Department was going into production on the weapon without having secured the approval of his board for the design. He considered the weapon already obsolete. His principal objection was that the rate of fire was too slow.²⁰

Miles' standard of comparison was the French Schneider-Canet 75 millimeter (2.95-inch) gun. The Schneider-Canet, said Miles, fired fixed ammunition, controlled recoil effectively with hydropneumatic cylinders, and was capable of twenty to twenty-four aimed shots per minute. In comparison, he noted that the rate of fire of the field gun in American service was one round per minute.²¹ Miles was speaking of the 3.2-inch weapon. Apparently, the Department had not established a rate of fire for its new 3-inch piece. Miles' resounding condemnation of the 3-inch gun may have been prematurely overstated; nevertheless, the Secretary of War ordered procurement of the American weapon stopped until the Board of Ordnance and Fortification established a standard type of field gun and carriage.²²

The gun that Buffington had proposed to produce was similar in some ways to the old 3.2-inch piece, but it was different in others. Both weapons were of proven built-up construction.²³ And like the modified models of the old gun, the new one was to use smokeless powder, which had become an ordnance standard. The greatest difference between the two guns was in the carriages. The old weapon had a rigid carriage, while the new piece was to have one that reduced recoil with hydraulic cylinders, assisted by a trail spade. The barrel was to be returned to battery by coil springs in the cylinders. In addition,²⁴ the carriage permitted a right and left traverse of 3 degrees. The breeches of both the old and new weapons were of the interrupted-screw

type. However, the mechanism of the 3-inch piece was of rapid-fire design; it opened with one motion, rather than the three movements needed to work the 3.2-inch breech.²⁵ Both the carriage and the breech of the new weapon would have contributed to a higher rate of fire. But taking two steps forward and then one backward, Buffington had rejected the metallic cartridge; and this omission greatly disturbed Miles.²⁶

In his rejection of the brass cartridge, Buffington was torn between two considerations. First, fixed ammunition helped to increase the rate of fire of field guns, which, of course, demanded a greater ammunition supply. But the brass case increased the weight of ammunition, reducing the amount that could be carried in a caisson behind a six horse team. A six gun 3-inch battery with nine caissons could carry a maximum of 1,485 rounds of separate-loading ammunition, while the same organization could haul only 1,188 rounds of the metallic case variety.²⁷ It is a tribute to the persistence of established concepts that it was not until 1903, that a new Chief of Ordnance finally took a step that seems obvious in retrospect and recommended that the number of caissons in a battery be increased. It is notable that the request came from the Ordnance Department rather than the Artillery.²⁸

In any event, as of August 1900, Buffington's plans to produce the 3-inch gun with separate-loading ammunition were halted. In the final analysis Miles was right, not so much because of the fixed ammunition question, although the issue was not unimportant, but because the 3-inch piece was to be a short-recoil weapon. The cylinders absorbed only a portion of the recoil; the carriage still jumped when the weapon fired. When Miles made reference to the Schneider-Canet gun, he may

have had it confused with the new field piece of the French Army. Both were long-recoil guns, designed to absorb most, if not all of the force of firing. However, the French army weapon was so efficient in recoil control that it was beginning to excite the envy of soldiers everywhere.

The French government began to develop its new 75 millimeter field gun in 1892. The Director of Artillery, General Charles P. Mathieu initiated a program to design a long-recoil gun for the French. Under the supervision of Colonel Albert Deport, and later, Captains Sainte-Claire Deville and Emile Rimailho, by 1897 government designers brought the "75" to perfection. The success of the gun was in the design of its hydropneumatic recuperator. The force of recoil pulled a piston against fluid, which in turn forced a second "floating" piston against trapped air, figure 30. When the energy of recoil was expended, the compressed air expanded, driving the barrel back into battery. The system was rather simple, but the secret to its success was in the seal around the "floating" piston, which kept the liquid and air separate, even though both were under great pressure. The action of the piece was so smooth that it was said that a glass of water placed on a wheel would not upset when the gun fired. The French prosecuted the design of the weapon in great secrecy; many parts were manufactured separately in a variety of shops and then assembled in one place by only a few technicians. In spite of the secrecy, reports of the efficiency of the new weapon soon circulated to other nations.

An article in the Army and Navy Journal, in March 1900, reported the appearance of the gun in the French maneuvers at Chalons. The weapon

FIGURE 30

FRENCH 75-MILLIMETER FIELD GUN

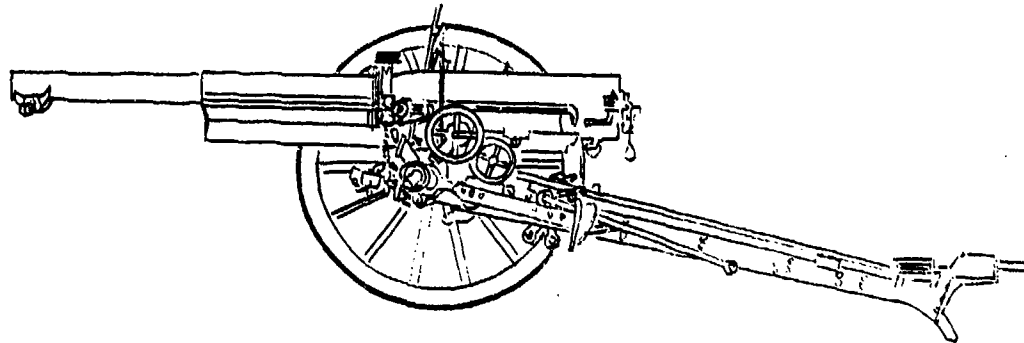

Field Gun

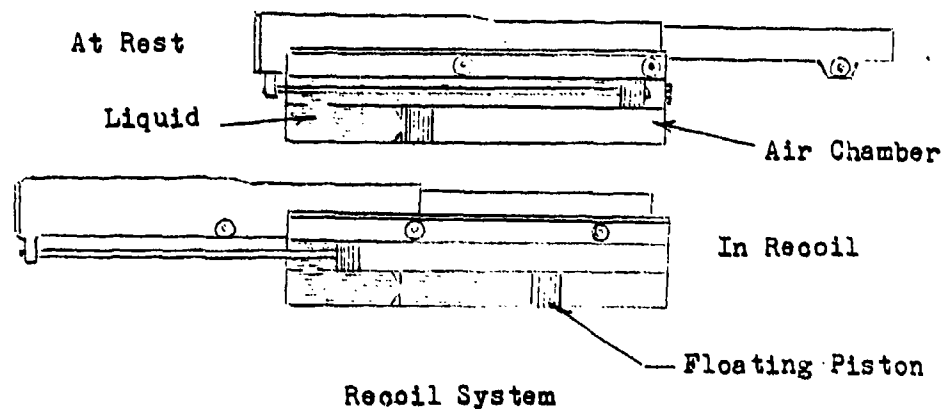

Recoil System

SOURCES: Andrew Hero, Jr., "French Rapid-Fire Field Artillery," Journal of the United States Artillery 19(1903):38; and Frank E. Comparato, Age of Great Guns: Cannon Kings and Cannoneers Who Forged the Firepower of Artillery (Harrisburg, Pennsylvania: Stackpole Company, 1965), p. 39.

NOTE: At rest, the air chamber was already pressured to almost 1,800 pounds per square inch. Recoil forced liquid from the upper to the lower chamber, further compressing the air. The stored energy returned the gun to battery. Ibid.

was described as firing fixed ammunition, being equipped with a shield,
and capable of a rate of fifteen shots per minute.³⁰ Actually, the
reported rate of fire was a little low. A well trained crew could put
twenty rounds down range in sixty seconds; and when equipped with a
semiautomatic breech that opened by itself and ejected each cartridge,
the gun was capable of 30 shots a minute.³¹ But information available
in the United States on the new gun was sparse.

Root sent Captain Lewis abroad in August and September of 1900
to investigate and report on European advances in artillery. He toured
ordnance plants in England, Germany, and France. In his report, he
lost no opportunity to criticize the American Ordnance Department for be-
ing a closed technological community, slow to adopt change, and inac-
cessible to artillery officers who had to accept and use its products
without the privilege of contributing to the designs. He asserted,
". . . we are nearly ten years behind the other great powers both in
a proper appreciation of the need of modern weapons and in the develop-
ment and construction of the weapons necessary to meet this need."³²
His observation was a bit overstated; the Department had done much to
catch up with the Europeans during the past decade--although it was slow
to decide on issues like smokeless propellant and high explosives.
Lewis was particularly impressed by the foreign interest in field artil-
lery, which he characterized as ". . . the one all-absorbing question in
Europe."³³ He echoed the sentiment of Miles that one of the new rapid-
fire French guns could outshoot an entire battery of American field
artillery.³⁴

In a letter through Miles, to Root--one that was separate from
his official report--Lewis said, "Through personal friends in Paris I

was fortunate enough to secure confidential information of such accurate technical character as to convince me that I am now informed as to every essential element of construction [of the French "75"]

He requested permission to superintend the building of a gun, based on his information, at a civilian foundry. The Board of Ordnance and Fortification reviewed the proposal on 10 November 1900 and allocated \$3,200 for Lewis to construct the weapon at the Bethlehem Steel Company.

The story was leaked, and it caused consternation in the War Department and a reported storm of indignation in the French press. The day after the board's action, The New York Herald and The Washington Post carried columns announcing that a War Department agent had possession of the French plans. The reaction in the French press was such that the American Charge d' Affaires, Henry Vignaud, felt that it was necessary to take the unusual step of making some reply. No doubt ill-informed, he announced through a Paris newspaper that, "No American naval or military officer has ever tried to find out any of the secrets of the French war organization." Although, the press kept the issue boiling, the incident did not rise to the proportions of an international crisis. Secretary of State John Hay informed Root that the French Minister of Foreign Affairs ". . . attaches no importance to the matter."

It was, nevertheless, an important issue within the War Department. Through Miles, Lewis requested an investigation to determine the source of the leak. The Department held a copy of a letter in which Lewis offered to build the gun. Moreover, the dispute between Buffington and Miles was public knowledge. It was easy to assume that the leak was a deliberate attempt

on the part of the Department to embarrass its twin nemeses, the Recorder and the President of the Board of Ordnance and Fortification. One newspaper speculated that the incident ". . . , may bring about sooner than was expected an open war between the Bureau [Ordnance Department] and the progressive artillery faction, headed by the general commanding the Army." ⁴³ The acting Secretary of War directed that ⁴⁴ Buffington make a report on any information given to the press. Buffington complied with the order by questioning each member of his office staff. The eight officers and ten civilians of the Ordnance office denied any part in the leak. ⁴⁵ Buffington then wrote to the Secretary of War recommending that the investigation be carried elsewhere, since other members of the board also had access to the information. He observed that he alone had ". . . subjected to the indignity of suspicion and . . . called upon officially for report." ⁴⁶ There is no doubt as to the sincerity of Buffington's indignation, for it was not until two days later that Major Clarence E. Dutton of the Ordnance Office came forward and admitted that he had shown Lewis' letter to a member of the Associated Press. The reporter was in Dutton's office looking for news; and the Major handed him the letter, without, as he said, considering the possible consequences. ⁴⁷ In view of his earlier letter to the Secretary of War, Buffington was no doubt embarrassed by Dutton's confession. The leak and its consequences were the result of an unpremeditated act by one subordinate in the Ordnance Office. Yet the initial suspicions and accusatory reactions that greeted the leak were indicative of the deteriorated relations between the Ordnance Department and what had become known as the "progressive artillery faction."

Having stopped the plans of the Department to produce a separate-loading, short-recoil 3-inch piece in 1900, the Board of Ordnance and Fortification had prepared a program of competitive tests to be conducted in late 1901 to select a new field gun. Several domestic and foreign⁴⁸ manufacturers indicated their intentions to enter the competition.

During the intervening year, the "progressive artillery faction" scored other victories. In the spring, Congress authorized the appointment of two additional artillery officers to the board, which gave the Artillery three representatives as opposed to one for the Ordnance Department. Root commented that it was part of a ". . . design to secure enlarged activity and usefulness for the artillery arm."⁴⁹ In August, the board recommended that two artillery officers be detailed⁵⁰ to represent it at the Sandy Hook proving ground. The recommendation was approved. It was a departure from established procedure; personnel stationed at the proving ground had normally been there under orders of the Ordnance Department. The two artillery officers were to be agents⁵¹ of the board, rather than the Department. In November, the senior artillery member of the board, Colonel John I. Rogers, informed the ordnance officer in charge of field artillery tests that the board intended ". . . to exercise exclusive direction and control of said tests."⁵² Rogers' pronouncement was the high-water mark of the "progressive artillery faction's" encroachment on Ordnance Department prerogatives. The Secretary of War, reversing his previous support of⁵³ the board, disapproved Rogers' action.

The shift in Root's support for the board was, no doubt, in part, a manifestation of his growing estrangement from Miles. He had become convinced that Miles had presidential ambitions. Philip Jessup, Root's

biographer, says that although Miles tended to be "uncooperative and insubordinate," the Secretary had tried to win him over to a policy of cooperation. The policy was tested when Miles and Root differed on the need to adhere to a strict seniority system of promotions to fill officer positions created by an expansion of the force serving in the Philippines. The matter was leaked to the press; Root was convinced that Miles had done it; and the policy of cooperation was fatally wounded. Miles also alienated Theodore Roosevelt when he hinted in a public speech in June 1901, that the President had not been at San Juan Hill. As a result of the Commanding General's growing difficulties with the Administration, Jessup reports that ". . . ; Root finally determined to crush him [,] and he did it ruthlessly." ⁵⁴ By undermining the President of the Board of Ordnance and Fortification, the vicissitudes of national politics blunted the thrust of the "progressive artillery faction" that had operated through the board. In effect, at the eleventh hour, fate rescued the imperiled prerogatives of the Ordnance Department from the hands of the artillerymen.

Fate intervened in another way on the side of the Department; Buffington retired after forty-five years of service, and Root reached deep within the ordnance hierarchy to elevate Captain William Crozier to the position of Chief. Crozier, who pinned on his stars in November 1901, was a particularly capable ordnance officer. Upon commissioning in 1876, he entered the Artillery. Five years later, he transferred to the Ordnance Department. He had collaborated with Buffington in the design of a disappearing seacoast carriage, and then he worked on his own plans for a wire-wound gun. Crozier attracted Root's attention in 1898 with a critical inspection report of the state of seacoast defenses.

In the report, Crozier asserted that artillery officers had allowed their skills to deteriorate even though they were supplied with first-class materiel. Artillery officers did not offer strong argument against the report, and Root took the moderate response as a sign that Crozier was respected by the gunners. He felt that the appointment of Crozier would help to establish good relations between the two branches. In addition, in 1899, Crozier had served with distinction as the American military representative to the International Peace Conference at the Hague. Examining the whole of Crozier's record, Root advanced him past twenty-seven officers, roughly from the middle of his corps. ⁵⁵

These two events, the break between Miles and Root, and the elevation of Crozier, did much to restore and insure the preeminence of the Department in matters of artillery materiel. The attempt by the Board of Ordnance and Fortification to extend its authority did however, have one beneficial and lasting effect: it forced the Department into the immediate consideration of long-recoil gun carriages.

In October 1901, the Department began competitive field gun trials at Sandy Hook. Eight weapons of both foreign and domestic manufacture were entered in the competition, table 6. The guns were of three basic classes: rigid carriage, short recoil, and long recoil. By February, ordnance officers had determined that the long-recoil weapons were indisputably superior to the rest, and, as a result, they eliminated the other two classes. The four remaining guns included Bethlehem Numbers 2 and 3, the Ehrhardt weapon, and Ordnance Department Number 1. Mechanical failures soon eliminated Bethlehem Number 3. The three remaining guns completed the trials, which included field marches and firings in the hands of artillerymen at Fort Riley, Kansas. The

TABLE 7

COMPETITIVE TEST OF FIELD ARTILLERY MATERIEL, 1902

Rigid carriage

Armstrong 3-inch

Cokerill-Nordenfelt 75-millimeter (2.95-inch)

Short-recoil carriage

Ordnance Department No. 1, 3-inch, model 1900, 2 hydraulic cylinders inclosing counterrecoil springs, permitting 8 inches of barrel recoil

Vickers-Maxim, 75-millimeter (2.95-inch), 2 hydraulic cylinders inclosing counterrecoil springs, permitting 14.25 inches of barrel recoil

Long-recoil

Bethlehem No. 2, 3-inch (Lewis gun), 1 hydraulic and 2 hydropneumatic cylinders inclosing counterrecoil springs, permitting 40 inches of barrel recoil

Bethlehem No. 3, 3-inch, 2 hydraulic cylinders, permitting 40 inches of barrel recoil, counterrecoil springs in trail.

Ehrhardt 3-inch, 1 hydraulic cylinder enveloped by counterrecoil, springs, permitting 53 inches of barrel recoil

Ordnance Department No. 1, 3-inch, model 1901, 2 hydraulic cylinders inclosing counterrecoil springs, permitting 46 inches of barrel recoil

SOURCE: U.S., War Department, Annual Reports of the War Department for the Fiscal Year Ended June 30, 1902 (Washington, D.C.: Government Printing Office, 1902), 12:129.

entire program of tests was finally concluded at Sandy Hook in
56

July 1902.

None of the three weapons was without its deficiencies. Only the Ehrhardt system was under the maximum weight restriction of 3,950 pounds. All of the weapons suffered mechanical breakdowns; but the Department entry had the smallest number, followed closely by the Ehrhardt gun. The Ordnance Board reserved its strongest criticism for
57
the Bethlehem weapon.

Bethlehem Gun Number 2 was the design superintended by Captain Lewis. It was based on the plans that he claimed to have brought back from France. The publicity that surrounded the gun exceeded its performance on the test range. Although Lewis used a hydropneumatic recoil system the Ordnance Board reported that, among other difficulties, the
58
jump of the wheels was excessive. Clearly, Lewis had not secured the secret to the French gun. Perhaps the French Foreign Minister knew that Lewis could not have ascertained the secret when he remarked that he attached no importance to the reported theft.

After the trials, the Ordnance Department proposed to combine the best features of the pieces that it had tested into a gun of its
59
own design. The resulting weapon was the 3-Inch Field Gun, Model 1902, figure 31. The weight of the entire system behind a six horse team to include gun, carriage, and limber was 3,800 pounds. The new weapon had a range of 6,250 yards at a maximum elevation of the 15 degrees. The muzzle velocity was 1,700 feet per second. It was of built-up steel construction with an interrupted-screw breech. The weapon featured a trail spike and a barrel traverse capability. A hydraulic cylinder in the carriage absorbed the force of recoil with a

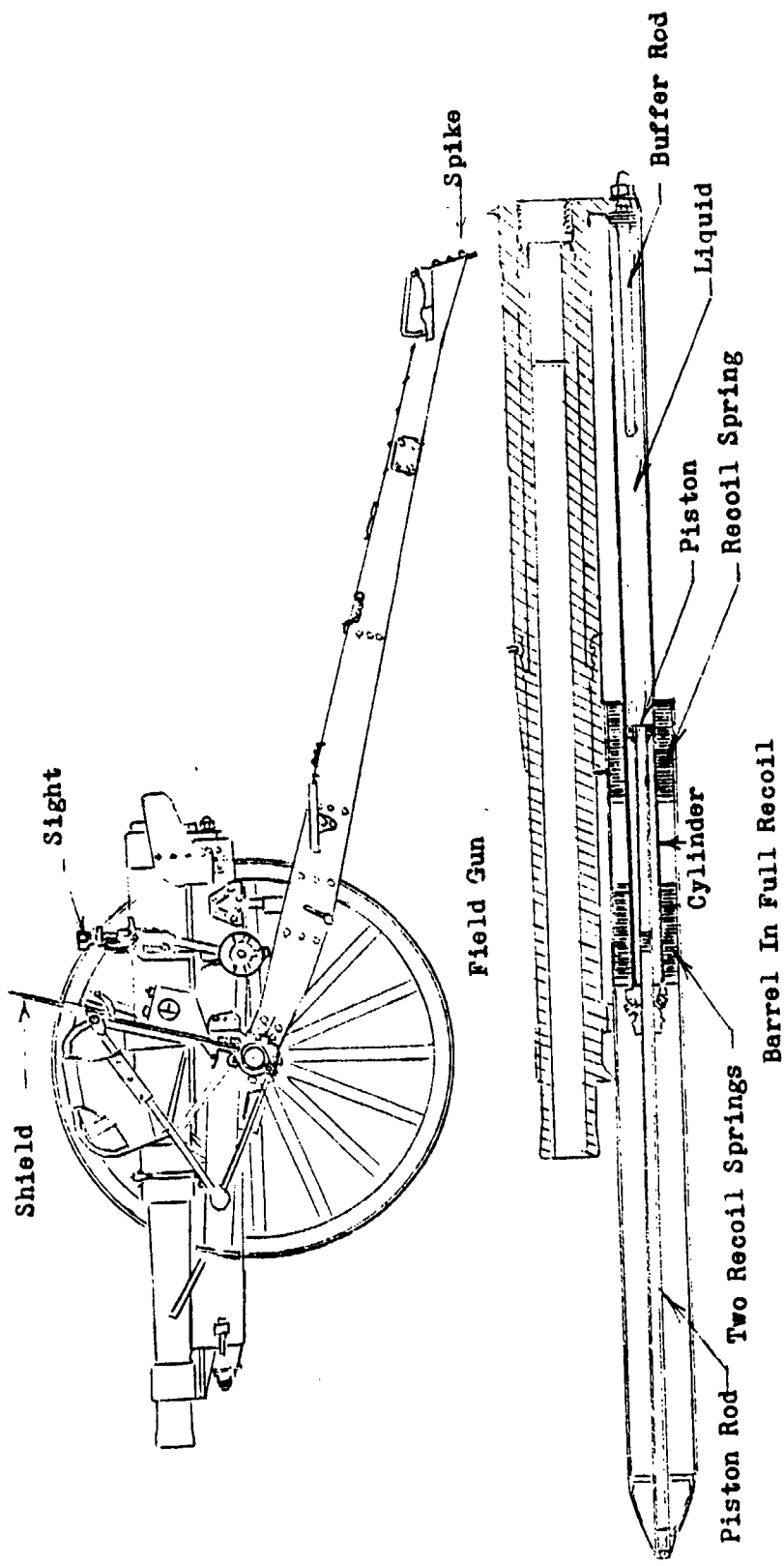

FIGURE 31

3-INCH FIELD GUN

SOURCE: U.S., War Department, Handbook of the 3-Inch Gun Materiel, Model of 1902, with Instructions for Its Care (Washington, D.C.: Government Printing Office, 1917), plates IX, XI.

NOTE: The piston remained fixed, while the cylinder moved. Liquid was forced through piston parts slowing recoil. Compression of the springs assisted recoil control. Expansion of the springs returned the barrel to battery. The force of return was eased by the displacement of liquid by the buffer rod.

smooth action, permitting the barrel to slide rearward for 48 inches. In comparison, the last short-recoil weapon tested by the Department stopped the barrel within 8 inches;⁶¹ the unexpended force quite naturally caused the weapon to jump. However, the Department had not mastered a hydropneumatic system. As a result, its new 3-inch piece would never be quite as good as the French "75." Nevertheless, like the "75," the 3-inch gun mounted a shield and fired at a claimed maximum rate of 20 rounds per minute.⁶² In 1904, the Department began to issue the new weapons to the field artillery. The same year, using the long-recoil concept, ordnance engineers began the construction of a 4.7-inch siege gun.⁶³ The problem of recoil control in mobile artillery was all but ended.

With the end of the recoil problem, optical sights for mobile artillery became practical. With a stationary carriage, there was no jolt upon discharge to damage sensitive sighting instruments. In February 1903, a German manufacturer of optical instruments, C. P. Goerz,⁶⁴ offered his new telescopic sight to the American Army, figure 32. The device was a radical departure from previous aiming instruments because it permitted a gunner to sight on a point at any angle from the gun without having to change his position. The eyepiece remained stationary, while the upper portion could be rotated in 360 degrees. The panoramic sight offered the image intensification advantages of a telescope and the accuracy of fine cross hair alignment with a point of aim. Mounted on a stationary carriage, it permitted the continuous, accurate sighting necessary for high rates of effective fire. In principal, it was similar, in many respects, to the periscope of a submarine--probably the example from which Goerz drew his inspiration.⁶⁵

FIGURE 32
PANORAMIC SIGHT

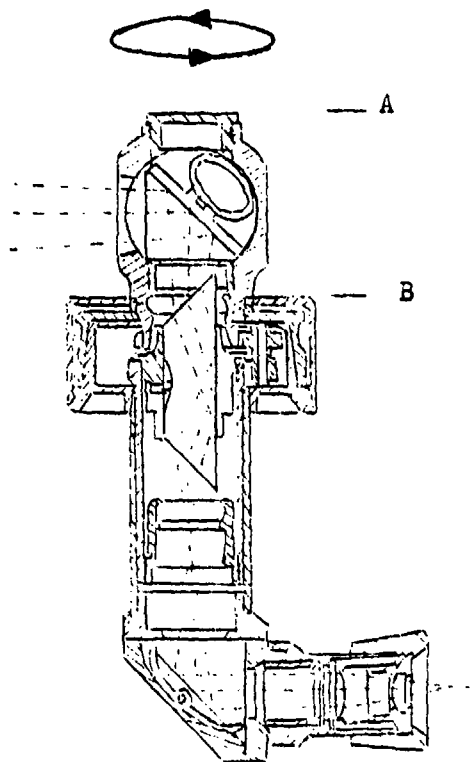

SOURCE: H. Korrodi, "The Panoramic Telescopic Sight," trans. C. T. Mencher, Journal of the United States Artillery 19(1903):312.

NOTE: Section A-B rotated to give a stationary gunner 360 degrees of vision.

Within a year, Crozier had one of the devices to test on his new field guns. Sold on it, he proceeded to arrange for production of the sights in the United States.⁶⁶ The rapid adoption of the sight was an example of Crozier's relatively progressive attitude toward mobile artillery development.⁶⁷

In fact, it can be said, as a general statement, that the United States had come abreast of Europe in the development of field artillery materiel. In specific cases America was actually ahead. For instance,⁶⁸ the Germans had not yet adapted along a long-recoil system.

Although methods of recoil control might vary, nearly every country in Europe had been thrown into a race to improve its field guns after the introduction of the French "75." Some countries sought to modify their existing weapons; others, like the United States held competitive trials. By 1901 Russia, Sweden, Italy, Spain, Norway, Rumania, Switzerland, and Belgium had invited gun manufacturers to display their wares.⁶⁹ A 1902 report of competitive trials in Holland reflects the seriousness of the drive toward higher rates of fire. The competition was between weapons manufactured by Schneider of France, and Ehrhardt and Krupp of Germany. Each gun was timed for its delivery of 20 rounds. The Schneider weapon took 160 seconds; the Ehrhardt, 60 seconds; and the Krupp, 49 seconds. In addition to its high rate of fire, the Krupp gun had the shortest time for delivery of the first round. The report observed that, ". . . in real warfare . . . , the gun that opens fire first will be victorious; it may even prevent the other gun from firing at all."⁷⁰ The British had purchased the Ehrhardt weapon, and by 1904, they were working on a long-recoil gun of their own design. The German Army, however, found itself in a dilemma. They had just finished

rearming with a short-recoil weapon, model 1896; and it was with some hesitancy that the country approached the great expense of completely reequipping its army again.⁷¹ It should be noted that the United States was spared a similar error when Miles stopped Buffington from going into production on his first 3-inch gun.

It was the French, however, among all nations that led the way in the adoption of rapid-fire, light field guns. They also led the way in new concepts of employment for field artillery. In his 1892 work, Field Artillery in Cooperation with Other Arms, General Hippolyte Langlois conceived the rafale, or shell-storm.⁷² The rafale was a sudden gust of battery fire, designed to bring havoc on an unsuspecting and exposed enemy. The concept was later incorporated into French drill regulations and expounded upon by Gabriel Rouquerol, an artillery major, whose book, The Tactical Employment of Quick-Firing Field Artillery, was translated into English in 1903 and widely circulated. The rafale, as described by the drill regulations, was a burst of battery fire, with each gun rapidly delivering a series of eight rounds. Gunners fired the first two shots based upon the battery commander's orders, and then they automatically added 100 meters for each succeeding set of two rounds. The impact area was an imaginary rectangle, roughly the width of a battery front.⁷³ Of course, it was all peacetime theory. The Germans rejected the concept of the rafale. They maintained that the tactical situation alone determined the rate of fire. In addition, in general, they considered preset adjustments, unrelated to a specific target, to be a waste of ammunition.⁷⁴ In the United States, Captain Oliver L. Spaulding, an instructor at the Infantry and Cavalry School at Fort Leavenworth, wrote in one of his published lectures that the

French seem to ". . . have gone too far in their theorizing."⁷⁵

Spaulding's opinions carried weight; he was becoming an intellectual leader among American artillerymen.⁷⁶

It is interesting that one result of the adoption of the rapid-fire gun was the birth of the idea that armies could get along with less artillery: the increased rate of fire making it possible to reduce the total number of guns carried into the field. For instance, the French reduced the number of guns in their "75" batteries to four.⁷⁷ In 1903, Secretary Root told the House Military Affairs Committee that new 3-inch materiel would make it possible to equip a given force of infantry with a much smaller number of guns. He thought that 1 gun per 1,000 soldiers would suffice where 3 had previously been required.⁷⁸ A year later, General Crozier gave it as his opinion that 2 rapid-fire guns per 1,000 men would probably be enough.⁷⁹ Again, it was all theory.

The French appreciated, perhaps better than anyone else, the power of rapid-fire guns, particularly when they were used against opposing artillery. For that reason, they were more receptive to the idea of indirect lay than the Germans, who continued to insist that the method only be used in exceptional circumstances. However, there was no fundamental difference in the two concepts of application; it was only a matter of degree. The French drill regulations specified that indirect lay was ". . . only admissible in cases where the tactical situation does not require fire to be directed on [from] the forward slope."⁸⁰ Spaulding's advice to American officers was similar. He recommended cover for guns, with just enough exposure so that the target could be seen through the sights. Although, "In some cases it may seem advisable to withdraw them even more . . . and have recourse to indirect

81
 laying." As a general statement, indirect lay was still an auxiliary technique for field artillerymen.

Methods of employment were related to the nature of the materiel. Rapid-fire guns like the American 3-inch piece and the French "75" have been called the first of modern artillery. But in many ways, they were the ultimate in design of the old artillery. They were mobile, light, low-trajectory weapons, as direct-fire artillery had always been. Recoil control permitted high rates of discharge, giving the new artillery unprecedented firepower. The elimination of recoil also made it possible for crews to stay behind their guns all of the time, making shields for protection against bullets and shrapnel practical, which in turn, promised to enhance the survivability of the weapons in forward deployment. In addition, as Rouquerol said, "The true projectile for modern field artillery is the shrapnel shell, . . ." 82
 Shrapnel was most effective against personnel in the open: the traditional target of field artillery. All of the above enhanced the usefulness of the new guns within the direct-fire concept of employment. The reason is quite simple: the paradigm had continued to dominate changes in materiel and tactics since the Civil War.

Although, in general, gun designers and artillerymen had become carried away with the new field pieces. There were some who argued for a different direction. For instance, in 1898, when interest in rapid-fire guns was beginning to rise, the Journal of the United States Artillery carried a series of articles by Major Tiedemann, of the German Army, in which he called for the assignment of howitzers and mortars to field batteries. 83
 And in 1903, when excitement over rapid-fire field guns was at its height, the Army and Navy Journal carried an

article by an English captain, C. Holmes Wilson, in which he stated a need for a weapon that could search cover. It:

. . . should be a howitzer, and should be mobile enough to keep pace with the infantry, . . . It should be . . . capable of rapid firing, . . . Behind these would come the heavy guns of large caliber drawn, possibly by traction engines . . . ⁸⁴

To its credit, by 1904, the American Ordnance Department had begun the construction of a 4.7-inch siege gun on a long-recoil carriage, and it had initiated the design of a 3.8-inch field piece; ⁸⁵ but, although these weapons would add weight to artillery fire, they were not howitzers. High-angle weapons had been ignored by the Department since the mid-1890's.

A set of rules for the conduct of field exercises provides insight into American artillery tactics in 1903. Except under favorable circumstances, such as the protection of cover, the artillery was not permitted to unlimber within 800 yards of enemy infantry. "This, however, should not prevent it from accompanying advancing lines under cover of their fire to a decisive attack." ⁸⁶ The American conception of employment was still one of guns aggressively handled to the front.

Between the reorganization of 1901 and the beginning of 1904, there had been a notable institutional change for the field artillery: the establishment of a permanent board. Wallace C. Randolph, the Chief of Artillery, had recommended the formation of the board in June 1902, ⁸⁷ and within a few months it was in operation at Fort Riley, Kansas. The board contained much talent; among its members were a future Chief of Staff, Captain Peyton C. March and a future Chief of Artillery, Captain William J. Snow. The board was the first permanent test agency established by the Army, outside of the Ordnance Department, for the evaluation of field artillery materiel. In the past, batteries had

been selected on a one time basis to field test specific items of equipment. The board did not supersede the functions of the Ordnance Department, but it did give the field artillery a qualified forum to evaluate the products of weapons designers. In addition to its materiel evaluation functions, the board reviewed actual and theoretical schemes of instruction for the field batteries. ⁸⁸ Although it was in its infancy, and its effect had not yet been felt, the board was a major step for the field artillery.

A second major step was the upgrading of the course at the Cavalry and Field Artillery School. Whereas previously, the course had consisted primarily of drill and field exercises, the school expanded its curriculum in 1903 to include a variety of academic subjects. Among the courses were field engineering, military topography, and tactics. ⁸⁹ The school was not the academic equal of the institution at Fort Monroe, but it was started in that direction.

The field artillery had emerged from the Spanish-American War with its reputation tarnished. However, within six years, it had achieved a new importance, largely as a result of the nearly universal fascination with rapid-fire, long-recoil field pieces. If anything, its commitment to the direct-fire concept of employment had been strengthened during the period. Organization and tactics remained virtually unchanged. Institutionally, the branch profited from the establishment of a board sensitive to its particular needs; it profited also from the upgrading of the course at Fort Riley; although neither of these reforms was yet old enough to be felt to any significant degree. Such was the state of affairs in the field artillery when the first reports of the Russo-Japanese War began to reach the United States.

CHAPTER X

A REVOLUTION IN THE CONCEPT OF FIELD

ARTILLERY EMPLOYMENT

By 1904, the advance of technology had already provided all of the necessary ingredients for the implementation of a new concept of field artillery employment. All that was needed was a stimulus for change. That stimulus was provided by the example of the Russo-Japanese War.

On 8 February 1904, the Japanese Navy launched a surprise attack on the Russian fleet and shore defenses at Port Arthur on the Liaotung Peninsula of Manchuria. A few days later, the Japanese First Army landed in Korea and began a northward trek to the Yalu River. Defeating a Russian force there in early May, the First Army advanced into Manchuria. At the same time, the Japanese Second and Fourth Armies also landed on the Liaotung Peninsula. The Second Army turned south to seal the landward approaches to Port Arthur, and the Third Army soon arrived to take over responsibility for the investment of the Russian garrison. The subsequent siege of Port Arthur lasted until January 1905. Meanwhile, the First, Second, and Fourth Armies turned north to fight a steadily growing Russian field force. In a series of hard fought battles, beginning at Liaoyang in August and ending at Mukden in March 1905, the Japanese drove the Russians deep into
1
Manchuria.

In the fall of 1904, reports of the war began to appear in the

American press. The efficiency of the artillery, particularly that of the Japanese, universally impressed observers. One of the more vivid and succinct accounts was written by Thomas F. Millard for Scribner's Magazine, The Army and Navy Journal reprinted parts of the article for its own readers.

In this war we have seen battles with a fighting front of more than forty miles; . . . an advance of either party quickly resulting in a collision. One consequence of this is the great prolongation of battles instead of their quick decision . . . In this war we have seen battles which lasted ten days, . . .

At Liao-Yang . . . Some Russian batteries fired more than 600 rounds per gun, . . . More ammunition has been used in a single day in Manchuria than was required to fight the Spanish-American War.

The old dashing use of Artillery like that of cavalry, is no longer possible . . . We no longer see batteries dashing at full gallop across a battlefield, the limbers and guns bounding madly after excited animals to take up a new position. It is seldom that any considerable part of an army's artillery changes position during an action, . . .

Hardly any opportunity for initiative remains to battery commanders. Engineers select their positions . . . The effects of the fire are observed by officers appointed to that duty, . . . communicating by telephone with artillery chiefs who alone comprehend what is going on. The guns are hidden and the battery commander probably cannot see fifty feet in any direction.²

Both sides used artillery extensively. There was no question of the new importance of cannons. As an American General Staff report said: "There has been a school of theorists in the United States Army who have insisted that the effect of field artillery was largely moral. The facts, as shown by this war, demonstrate the complete falsity of such a supposition."³ The same report held that, "The losses caused by artillery fire have been decidedly greater than in any previous war, . . ."⁴ At Liaoyang, in some trenches, 75 percent of the casualties were attributed to artillery.⁵

The Japanese made the best use of their guns. It was not

necessarily a matter of superior materiel. The Japanese field gun, the 75 millimeter Arisaka, was a short-recoil weapon; the rate of fire was only seven shots per minute.⁶ Originally, the gun did not have a shield, although the Japanese began to adopt an improvised, wooden protective plate before the war ended.⁷ The principal Russian field gun was a 3-inch long-recoil weapon. The range of the Russian gun was about 1,000 yards better than that of the Japanese piece. Like the Japanese, the Russians entered the war without shields for their field artillery, although they attached the devices to the improved guns that they rushed into production.⁸ Also, the field pieces of neither side had panoramic sights.⁹ However, overall, the Russian field gun was decidedly superior to that of the Japanese.

On the other hand, in general, the Japanese enjoyed an advantage in heavy artillery. In Manchuria, beginning at Liaoyang, the Russians employed 4.2-inch siege guns. In later battles, they brought howitzers of up to 15-centimeter (5.9-inch) and guns of up to 6-inch to the front. The Japanese hauled 15-centimeter howitzers to the Yalu, but from there, the army proceeded without them. Rough country made it difficult to move even light artillery. Later, however, the Japanese made use of captured 10.5-centimeter (4.1-inch) guns and even managed to bring some of their 15-centimeter howitzers up the peninsula from operations around Port Arthur. As the war in Manchuria progressed, the Japanese moved siege guns and howitzers, some as large as 11-inch, up to their armies fighting from Liaoyang to Mukden.¹⁰ Heavy artillery played a role in the fights to the north, but it was at Port Arthur that the big guns had their greatest effect.

The Japanese closed on the outer defenses of Port Arthur

equipped with only their light artillery, while the Russian positions contained weapons of heavier caliber. Initially, the Japanese captured some of the Russian pieces; but it was not until the invaders brought their heavy howitzers down from the Yalu that their artillery became formidable. To supplement their artillery, the Russians took guns off the ships of their trapped fleet, some as large as 6-inch, and hauled them, with much effort, to the heights above Port Arthur. As the Japanese lines tightened around the port, they expanded their heavy artillery force, bringing weapons from Japan and even removing guns from the blockading fleet. ¹¹ One American military observer was particularly impressed with the high proportion of howitzers in the Japanese force; 62 as compared with 270 guns. As the siege progressed, the invaders brought eighteen 28-centimeter (11-inch) howitzers from the coast defenses of Japan. It was an action unprecedented in warfare. Each howitzer weighed nearly 23,000 pounds; the carriage and metal platform weighed even more. ¹² Ship and rail transportation brought the coast defense weapons close the front, and gangs of up to five hundred men ¹³ dragged them to their final positions. With 484 pound shells, the howitzers pounded Russian defensive positions and the port. In all, to include heavy and light weapons, the Japanese massed 428 pieces of ¹⁴ artillery against Port Arthur.

The method by which the Japanese controlled the fire of their guns was no less important than number and size of their weapons. One officer controlled all of the siege artillery. He had telephonic communication with observers and with each siege artillery regiment and separate group. In addition, a field howitzer regiment came under his control. He assigned objectives to subordinate commanders, often

specifying the rate and number of rounds to be fired. Regimental commanders, at their observation posts, had telephonic communications down to the firing units, batteries or platoons, depending on the type of artillery. Firing units maintained their own observation posts, communicating with the guns by voice or messenger. The Japanese had prepared accurate maps of the area, on a scale of 1 to 20,000. They ruled the maps with 1 centimeter squares, and thereby, were able to centrally direct fire by reference to specific locations on the grid.¹⁵ The siege artillery commander did not have control of the field batteries.¹⁶ Each Japanese division had a field artillery regiment, which generally consisted of two battalions of three batteries, each with six guns. In addition, a Japanese corps had a field artillery brigade,¹⁷ also organized into regiments, battalions, and batteries. The various echelons of the field artillery regiments were tied together by telephone, and fire was controlled in much the same way that it was conducted in the siege organization.¹⁸

The Japanese had used telephones for military purposes for several years. In 1890, they adopted the devices for fire direction at coast defense installations. Seven years later, they began to issue a model for field service.¹⁹ By 1904, the military potential of the invention was no novelty to them.

The same is true of modern tactics and organization. As early as 1862, the Japanese began to organize their army along Western lines, looking first to Dutch traders for information and then to the French with a formal request for instructors. The French responded, but with the rise of Germany after the War of 1870, the Japanese soon turned to that nation for military advice. In 1885, the Germans sent a General

Staff officer, Major Klemense W. J. Meckel, to assist the Japanese.

21

Meckel taught at the staff college until 1888. Two German officers continued Meckel's work for a short period after his departure, but the Japanese allowed their contracts to expire. Having absorbed what they wanted, the Japanese ended their dependence on foreign instruction. They did, however, continue to subscribe to various German service regulations as the documents became available.

22

The modernized Japanese Army, of course, had its own talent. General Iwao Ohyama was Commandant of Artillery in the prewar period; tactics and techniques were his responsibility. The development of communications systems fell to the pioneer branch of the service, under the direction of General Yuusuke Vehara. Technology, foreign instruction, and professional competence well prepared the Japanese Army for its war with Russia.

23

The nature of the war, however, ultimately determined the utility of specific techniques. Unlike the earlier low-intensity conflicts in Cuba and South Africa, the war between Japan and Russia saw the clash of large armies, reasonably well armed with weapons of great lethality to exposed infantrymen. The result was the habitual use of extensive lines of trenches, both at Port Arthur and in the campaigns to the north. In addition, the effectiveness of opposing artillery tended to drive guns to cover.

24

Both armies eventually made extensive use of the technique of laying guns indirectly from behind cover. Generally, at Port Arthur, all of the howitzers and mortars of the Japanese siege artillery fired from behind cover. Many of the big low-trajectory guns, however, were aimed by direct lay; and these drew the heaviest fire in reply. When

25

they had to use exposed positions, the Japanese took great care in their selections. The Russians, on the other hand, carelessly exposed their heavy batteries on the skyline, with the result that many were destroyed.²⁶ Japanese field batteries were generally deployed forward of the siege positions, in the low hills that separated the massifs occupied by the heavy artillery of the opposing armies.²⁷ The Japanese used their field artillery in both the direct and indirect mode. The former method predominated at Port Arthur. At the beginning of the siege, they held the guns back at ranges of 3,500 to 5,000 yards. As the campaign progressed and Russian artillery fire slackened, they pushed some of their pieces to within 1,000 and even 500 yards of the enemy line. The moves were usually made at night, and the guns were concealed until the moment to commence support for an infantry assault.²⁸ In the campaigns to the north, both sides made use of indirect lay. At first, the Russians tended to disdain the technique. But their exposed batteries were bloodied at Liaoyang; and from then on they increasingly turned to indirect lay. Copying the Japanese, they began to centralize the control of batteries with telephone lines. The Japanese continued to employ field guns by both direct and indirect methods, although, like the Russians they turned increasingly to the latter tactic.²⁹ At Liaoyang, they hid their guns behind stands of tall kaoliang grain; and in later engagements, after the Manchurian crops had been harvested, they used the high shocks for concealment.³⁰ As a general statement, reliance on indirect lay began with the howitzers and mortars of the Japanese heavy artillery and they spread to the field batteries of both sides by war's end.

The Japanese used their heavy artillery effectively at Port

Arthur to destroy Russian fortifications that refused to yield to light guns and infantry attacks. The 203-Meter Hill position was a particularly difficult objective. The Russians used thick overhead cover that was immune to shrapnel and the light concussions of field gun shells. It was not until the heavy artillery, led by the 28-centimeter howitzers, battered the Russian trenches that Japanese were able to carry the position.³¹

The Japanese had an additional advantage over the Russians in the destruction of defenses; they employed high explosive shells. The Japanese used high explosive ammunition with both heavy and light artillery. There was some difference in opinion among observers as to the precise type of explosive used by the Japanese; but it appeared that some of the heavy artillery, particularly the naval batteries, used Shimose powder, a Japanese compound, while light artillery shells were charged with picric acid.³² The Russians were impressed by the ability of high explosive shells to destroy covered positions; and they were embarrassed by their own lack of the effective ammunition. They had a small amount for heavy artillery, but it was not nearly enough. Shrapnel, however, also received praise. The Japanese had by no means abandoned this ammunition; two-thirds to three-fourths of their field gun supply was shrapnel.³³ It readily drove exposed infantry into trenches, and then high explosive shells did their work.

Perhaps the most penetrating lesson of the war was the power of the Japanese concentration of fire. Captain Carl Reichman, an American observer with the Russian Army in the field, commented: "The long range of the modern gun permits of a concentration of fire on any desired point without change of position, . . ." ³⁴ With their efficient

system of fire control, the Japanese were able to mass the effects of widely dispersed batteries. In contrast, the Russians had put their faith in a method similar to the rafale made popular by the French: rapid delivery of evenly spaced rounds. The Russians would fire a quick sweep and then rest for one or two minutes. Japanese gunners would then emerge from their trenches and continue their slower but more effective fire. ³⁵ When the Russians finally began to adopt methods of fire control similar to those of the Japanese, they had some difficulty implementing the unpractical system. ³⁶ One American artilleryman, Captain Tiemann N. Horn, observed without hesitation that the ". . . the idea of rapidity taking the place of concentration was exploded." ³⁷ It was not an unreasonable fate for a theory derived in ³⁸ peace.

The United States sent several military observers to the war. Among others, Lieutenant Colonel Edward J. M'Clernand, Major Joseph E. Kuhn, and Captains Peyton C. March and J. F. Morrison were with the Japanese, while Lieutenant Colonel W. S. Schuyler and Captain Carl ³⁹ Reichman were the Russians. Each of these officers reported his observations in detail to the War Department.

The Chief of Artillery, Brigadier General John P. Story, recognized the significance of the artillery lessons of the war. In his annual report, completed on 3 November 1904, he criticized the antiquated organization of the American field artillery, calling for the establishment of formal regiments and battalions. He pointed out that there was not one senior field grade officer in the entire field artillery branch. ⁴⁰ The Army had already taken the step in September of collecting the thirty batteries into battalions, generally of two

batteries each: however, they were only provisional groupings. In addition to his complaint about the organization of the field artillery, Story attacked a General Staff decision, made before the land battles in Manchuria, that 2 guns per 1,000 men was a sufficient ratio.

President Theodore Roosevelt himself was impressed by the performance of artillery in Manchuria. His interest was stimulated, not by Story's report, which perhaps he had not yet seen but by a letter from an American correspondent, James F. J. Archibald, who was with the Russian forces. On 1 December, Roosevelt wrote to the Secretary of War, "What steps have been taken to practice and develop our artillery."

It was an extraordinary expression of concern for the branch. Presidential interest did not end with the first note; Roosevelt followed it in January with a request for a formal report on the status of the field artillery, ". . . and what efforts are being made to secure its proper use in battle." Story's honest reply was that little had been done beyond ". . . epistolary efforts, by the Chief of Artillery and other artillery officers." Roosevelt's reaction was, "General Story's report certainly shows that the present status of the field artillery is most unsatisfactory."

It was not weapons, but organization and tactics that were the source of concern. Story reported that the condition of the field artillery materiel had simply outrun the concepts of its employment.

Story summed up many of the lessons of the Russo-Japanese War. He noted that although the Japanese were inferior to the Russians in field gun materiel, they constantly outperformed their adversaries through superior gunnery, organization, and methods of fire. He was convinced that the proper utilization of artillery in the future would

demand fire regulated through an echeloned organization by telephonic communication. In addition, he felt that it would be seldom when indirect lay was not used.⁴⁹

The process to revise the organization of the Artillery began in the autumn of 1904, after the receipt of Story's annual report.

Secretary Taft sought the advice of the General Staff on a proposed five thousand man increase for the Artillery Corps. Much of the increase was to go to the coast artillery, but he recognized the inadequate proportion of field artillery in the maneuver army. The difficulty was that he sought to increase the Artillery by reducing the

other branches, rather than by increasing the total strength of the Army.⁵⁰

Taft should have known that this impolitic suggestion would be strongly opposed by the General Staff, which is what happened. The officers did, however, recommend that both the field and coast artillery be increased and reorganized as entirely separate branches.⁵¹

Roosevelt solicited the views of the Chief of Artillery on the proposal.

Story replied that he was in favor of a separation, if the field artillery was given a regimental organization at the same time.⁵² It was

certainly an unselfish act on Story's part, for he would lose part of the Artillery Corps if the separation became effective. The Chief of Artillery went further; he recommended that the field branch be expanded, not just to a proper proportion in the Regular Army, but to a size that would suffice if the infantry were suddenly expanded upon a declaration of war.⁵³

Earlier, Story had criticized the General Staff for its recommendation that a proper ratio of guns to men was about 2 per 1,000. In April 1905, he queried the General Staff for another opinion on the

54
matter. Apparently somewhat sensitive about the issue, even though the initial recommendation was made before the war in Manchuria, the acting chief of the First Division of the Staff replied that the figure "2" was a popular misconception and that the actual number was 3.15. The previous official ratio, as established by Field Service Regulations, had been 2.1 guns per 1,000 troops of other arms. Nevertheless, as a result of the testimony of liaison officers who had returned from Manchuria, the General Staff recommended that the new ratio be 3.35 guns per 1,000 infantry. In comparison, the number of guns per 1,000 infantry of other nations was: Japan 3.76, Russia 3.65, Germany 5.76 and France 3.30.⁵⁵ With the exception of Germany, the new General Staff recommendation placed the United States close to the other major powers.⁵⁶

Of course, it was not just numbers but a major reorganization that was needed to give efficiency to American field artillery. In response to Roosevelt's January interrogative, Story requested a study by the Board for the Preparation of Field Artillery Drill Regulations. In its report, the board recommended that the field artillery be organized into regiments of three battalions composed of two batteries.⁵⁷ Captain Peyton March, a liaison officer in Manchuria, was impressed by the Japanese organization; he recommended regiments of two battalions, each with three batteries. March had some influence with Story. The Chief of Artillery decided to experiment with both proposals; he recommended that a provisional regiment on each plan be formed, one at Fort Riley, Kansas, the other at Fort Sill, Oklahoma.⁵⁸ The War Department ordered the two regiments into being on 14 June 1905, and the field artillery had at last arrived at modern organization.⁵⁹ However, the units were only provisional; they still had to be confirmed by law.

Within a few months after the fall of Port Arthur, the American Army had raised the accepted ratio of guns to infantry and had initiated a modern organization for the field artillery. The speed, however, was no more rapid than the move to secure fire control equipment for the branch.

By May 1905, the Board on the Preparation of Drill Regulations for Field Artillery was hard at work on a fire control system. The Ordnance Department had a range finder and plotting board under design, and the Chief Signal Officer soon sent what equipment he had to Fort Riley for evaluation. There seemed to be a rush to claim credit for initiating fire control in the field artillery. The Chief of Artillery stated that the organization of the provisional regiments permitted some practice of methods, although the necessary equipment was not complete; and the Chief Signal Officer asserted that he had initiated action through the General Staff that caused the board to consider a fire control system in the first place. Personal efforts aside, it was the lessons of the Russo-Japanese War that drove the introduction of fire control into the American field artillery system. However, years of neglect were not easily overcome, and it was only after much test and experimentation that the Chief Signal Officer announced in 1908 that his department was issuing standardized fire control equipment.

Hardly one to be left behind, Crozier was doing his part to modernize the field artillery. As stated previously, in 1904, he had a 4.7-inch siege gun on a long-recoil carriage under construction, and a 3.8-inch field piece under design. The siege gun had a maximum elevation of 15 degrees, and that of the field piece was only 1/2 degree more. Although the weapons were low-trajectory types, they were of

heavier calibers than had been designed in recent years. To his credit, Crozier fought advice to build guns lighter than the 3-inch piece. He rejected claims that a 2-inch cannon, with a high rate of fire, would exceed the effect of a 3-inch piece.⁶⁴ The next year it was apparent that the lessons of the Russo-Japanese War had not been lost on the Chief of Ordnance; he stated, "The mobile artillery of an army should contain a certain number of howitzers for searching out trenches, . . ."⁶⁵ Following through with his observation, he proposed to build howitzers of 3.8-inch and 4.7-inch on long-recoil carriages for field use. In addition, he announced that a 6-inch siege howitzer was under design.⁶⁶ All howitzer carriages permitted an elevation of 40 degrees.⁶⁷ Crozier, however, was not interested in cannons alone.

In 1903, the Ordnance Department had ordered an automotive wagon, built to its specifications, from a civilian manufacturer. It was Crozier's intention to test the machine as a battery wagon, a vehicle for hauling the tools and supplies of an artillery unit. The 28-horsepower, 4-cylinder wagon was even equipped with a winch, to pull itself from the mud. There was no thought, however, of committing it to the rough terrain encountered by horse teams deploying guns in combat.⁶⁸ The vehicle was to be used on roads. But even there, a problem arose: fully equipped, at 12,000 pounds, it was too heavy for the bridges of country lanes. The Department had to go back to the design process.⁶⁹ Nevertheless, it was a hesitant start at bringing automotive power to the field artillery, although it would still be several years before much would come of the idea.

Having launched the howitzer program, Crozier turned his attention to building a reserve of field guns in order to supply an expanded

army in the event of another war. In 1906, he reported that all of the Regular batteries and several militia units had been equipped with the 3-inch gun. But he observed that the nation would need at least 250 batteries in the time of war, well above the number in the organized forces. As a result, he was allocating funds to build a separate reserve.⁷⁰ He had the support of the Secretary of War and the Chief of Staff, but Congress was not appropriating enough money for field materiel to finance construction at the rate that Crozier thought necessary. The Chief of Ordnance adjusted to the situation by modifying some of the old 3.2-inch guns, in part, with funds available from another account.⁷¹ As a Chief of Ordnance, Crozier was both progressive and resourceful.

Modern war required large quantities of ammunition as well as guns. Drawing upon the Russo-Japanese conflict as an example, the new Chief of Artillery, Brigadier General Arthur Murray, strongly recommended that the available supply of projectiles for field pieces be increased three-fold, to at least 1,000 rounds per gun. He observed that the rapid fire capability of modern artillery was useless without an adequate supply of ammunition. Murray made the recommendation in the last report signed by a Chief of Artillery as head of both branches.⁷²

In January 1907, the President signed a bill permanently separating the Field from the Coast Artillery.⁷³ The Chief of Artillery superintended the transition, relinquishing control over the field branch in July 1908.⁷⁴ The new Field Artillery consisted of six regiments. Each regiment was formed of two battalions, each with three batteries. Murray remarked that the organization ". . . closely followed the teachings of the Russo-Japanese War."⁷⁵ He added that a large number of

artillerymen favored an alternate organization of three battalions of two batteries.⁷⁶ In that age of slow promotions, the increased number of field grade positions inherent in the latter organization no doubt played some part in the popularity of the three battalion scheme.

Three of the regiments were organized as light artillery; two,⁷⁷ as mountain artillery, and one, as horse artillery. The horse artillery, of course, was to support the cavalry. Mountain artillery consisted of guns that could be dismantled for pack transportation. It was, in effect, field artillery; there was little difference between the drill regulations for the two types.⁷⁸

There were no siege batteries provided in the new organization. After the war with Spain, the Army had retained two siege batteries in its Regular establishment. That in itself was a significant departure from the past practice of maintaining no formal organization for the siege weapons. But in 1907, the siege materiel constructed in the mid-1890's was considered obsolete, and artillerymen turned it in, temporarily drawing light guns. The Chief of Artillery was careful to explain that the importance of heavy materiel was not disparaged by the exchange of materiel. He stated that, "On the contrary, this is an indispensable element of field artillery, . . .," and that the batteries would be re-issued heavy artillery as soon as the Ordnance Department furnished equipment. Although the Ordnance Department was working on heavy artillery, it had not yet completed enough of the new materiel to issue any to the field service.⁷⁹

There was no lack of interest in heavy artillery. In the fall of 1907, the Field Artillery conducted tests at Fort Riley on the effects of high explosive shells on field fortifications. For the

evaluation, gunners used 3-inch field pieces as well as obsolete siege materiel, 5-inch guns and 7-inch howitzers. ⁸⁰ The light pieces did little damage to the works; the 5-inch guns did more; but the large howitzers tore up bombproofs, smashed reinforcing timbers, and destroyed tunnels with relative ease. The shells were loaded with a compound of picrate of ammonia. There was some problem with projectiles failing to detonate, but, in all, the test was a much needed and successful ⁸¹ evaluation of the destructive effect of heavy, high explosive ammunition. Like much the Army had done since 1905, interest in the destruction of earthworks by high explosives was stimulated by the lessons of the Russo-Japanese War.

It is important, that in 1909 the Chief of Ordnance stopped using the term "siege" to describe the heavy weapons he was preparing for the maneuver army. ⁸² The larger pieces were still less mobile than field guns; they were designed, as in the past, to be hauled by teams of eight horses. ⁸³ But, since the Manchurian war, the old concept of siege artillery as weapons of special application had progressively given way to one in which they were considered to be part of the normal complement of a field army's equipment.

Nowhere is the trend more evident than in the artillery organization for a field army proposed by the General Staff in 1912, table 7. Howitzers of 4.7-inch were to be assigned down to divisions, and the largest weapons under construction by the Ordnance Department, guns of 4.7-inch and howitzers of 6-inch, were allocated to army artillery. ⁸⁴ The days of the siege train were gone.

With the amalgamation of siege and field pieces, the transition to a concept of indirect fire can be said to be complete. The objective

TABLE 7

GENERAL STAFF RECOMMENDATION FOR THE ORGANIZATION OF
THE FIELD ARTILLERY, 1912

For each infantry division:

<u>An artillery brigade, with:</u>	<u>weapons</u>
1 regiment of 3 battalions:	
1 battalion of 3 batteries of four 3-inch guns	12
1 battalion of 3 batteries of four 3-inch guns	12
1 battalion of 2 batteries of four 3.8-inch howitzers	8
1 regiment of 3 battalions:	
1 battalion of 3 batteries of four 3-inch guns	12
1 battalion of 3 batteries of four 3-inch guns	12
1 battalion of 2 batteries of four 4.7-inch howitzers	8

For each field army in addition to divisional artillery:

1 regiment of 2 battalions, with:	
1 battalion of 2 batteries of four 4.7-inch guns	8
1 battalion of 2 batteries of four 6-inch howitzers	8

SOURCE: U.S., War Department, Annual Reports of the War Department for the Fiscal Year Ended 30 June 1912 (Washington, D.C.: Government Printing Office, 1913), 1:107, 116.

NOTES:

1. It might be noted that the proposed artillery support for a division had grown to a brigade of 2 regiments, each of which contained 3 battalions. The proposed increase as of 1912 goes too far beyond the chronological scope of this study to cover it in detail; it is enough to say that it was part of the continuing emphasis on field artillery that began with the lessons of the Russo-Japanese War.

2. The field army was to consist of 3 infantry divisions and a cavalry division equivalent. The cavalry was to have its own regiment of horse artillery.

manifestations of the concept--materiel, tactics, organization, and the ratio of guns to troops--all would undergo farther refinement; but the basic concept itself had already shifted paradigms, clearly as a result of the perceived lessons of the Russo-Japanese conflict.

Before 1904, the American concept of field artillery employment was essentially one of direct fire. The objective manifestations, particularly materiel, had changed since the Civil War; but the prevailing paradigm had given its own direction to the changes. Field artillery pieces were still light, low-trajectory weapons; and heavier guns, howitzers, and mortars were still reserved for special use. Although improved design gave range and accuracy to field artillery, soldiers visualized its employment forward, in relatively close proximity to the enemy, firing under the voice direction of the battalion and battery commanders, who observed fire from the location of the guns. Ordnance designers, in spite of the improvements that they made in materiel, were subject to the same perceptions, which, of course, gave direction to the improvements. The American artillery in Cuba was no more effective against entrenched infantry than it had been in Virginia, thirty-four years earlier.

Technology, however, had advanced substantially since the 1860's. Nearly all of the ingredients necessary for a doctrine of indirect fire were available by 1898. It was simply a matter of putting the system together. If the war with Spain had been of a different nature, with massed armies and a longer duration, the United States might have effected the transition itself. As it was, the Japanese did it first. They showed what could be accomplished with a heavy volume of concentrated, accurate fire, much of which was from high-angle weapons

firing from defilade positions. By the end of the war, engagement from defilade was a favored technique for both sides. Telephones brought the fire of many weapons together, providing the saturation needed, even with rifled weapons, to overwhelm the protection of field fortifications. Recoil reduction increased the rate of discharge of each piece and thereby added to the mass of fire, while, at the same time, contributing to accuracy. High explosives and large calibers added their share to the power of artillery. The concept of indirect fire appeared in the massing of these ingredients; and like the paradigm of direct fire before it, in the future, the new concept would give direction to its objective manifestations; materiel, tactics, organization, and relative numbers.

CONCLUSIONS

The ultimate purpose of this study has been to extract lessons on the nature of doctrinal change that might contribute to the insight of military planners. Admittedly, the study has the obvious weakness that it addresses a single example, American field artillery doctrine from 1861 to 1905; and as any layman statistician knows, a single example can only validate conclusions about itself. With this concession to the acknowledged authority of statistical proof, the author nevertheless wishes to draw conclusions from the study, framed, to some extent, in general terms. This is perhaps intellectually hazardous; but little harm can come of it, since the reader is free to accept or reject the author's conclusions based upon his own perceptions.

The investigation has gone beyond the obvious but superficial observation that doctrine changes because of willful initiatives by military thinkers--those whose position or intellectual stature give them influence over the selection of methods of combat. The role of such individuals is by no means unimportant; however, the study indicates that their contributions are the culmination of a complex process that tends to move with a momentum of its own.

Two phenomena emerge as most important in the process of change. The first is the persistence of the prevailing paradigm. The phenomenon is somewhat like what is often vaguely described as "institutional resistance to change." But the paradigm had an influence that extended beyond the operations of bureaucrats--the class generally associated

with institutional resistance to change. Military bureaucrats were influenced by the prevailing concept of field artillery employment-- direct fire; but they were no more subject to the dogma than other soldiers, or civilians who were involved with artillery. The concept of the employment manifested itself in four ways: tactics, organization, the ratio of guns to troops, and materiel. Each of these manifestations was capable of change with the advance of time; however, the paradigm gave direction to the changes; they tended to evolve toward maintenance of the efficiency of the old doctrine.

The evolution did not occur as an isolated event. It was part of a changing battlefield environment. For instance, the rifle drove the artillery back from its infantry targets, a tactical change. A subsequent restoration of some of the efficiency of cannons demanded an accuracy and range that only rifling could provide, which contributed to the abandonment of smoothbore guns, a materiel change. One change in the battlefield environment led to another; the threat posed by the increased range and accuracy of rifled, enemy artillery prompted gunners to search for positions that provided some cover from counter-battery fire, a minor tactical change. There are, of course, other examples of the influence of the changing battlefield environment on the manifestations of the doctrine; but the point to be made, without becoming repetitious, is that the changes in artillery employment were ultimately given direction by the direct-fire paradigm. The changes occurred largely as the result of attempts to maintain the efficiency of direct fire, consistent with perceptions of a changing battlefield situation. In essence, changes in the manifestations of the doctrine represented efforts to do more of the same, albeit in a different way.

This study is oriented primarily on considerations of battle-field efficiency. To prevent a distortion of the total picture, however, it is necessary to remind the reader that changes in the manifestations of a doctrine can be subject to additional influences. The best example in this study is the pattern of organizational change. The field batteries remained submerged in regiments numerically dominated by coast artillery until after the turn of the century. This condition can be attributed to traditional American perceptions of the employment of field guns; but light artillerymen, particularly during the Civil War, campaigned for a hierarchial organization for their arm. The campaign was certainly influenced by two considerations: a genuine concern for combat efficiency on one hand, and an understandable desire for promotion and institutional aggrandizement on the other. The latter motives are difficult to separate from the former, but it is important to recognize that they do exist. A second example is the support of artillerymen for the reorganization of 1901, which promised increased rank for officers but did nothing for the efficiency of the field batteries. It is a demonstration of the ability of other considerations to rise above concern for efficiency. The point is that soldiers' support for a particular form of a doctrinal manifestation is not always tied exclusively to perceptions of battlefield efficiency.

The persistence of the prevailing paradigm is one important phenomenon to emerge from the study; the importance of technology in the process of doctrinal change is another. Of all of the manifestations of the doctrine, materiel experienced the greatest improvement with the advance of time. Like the rest of the manifestations, however, it was given direction by the paradigm of direct fire.

During the Civil War, when the problem of the rifle and the trench degraded the efficiency of field artillery, the state of technology was such that there was no apparent solution to the difficulty. In fact, it was not even perceived that the artillery might provide an eventual solution. Although ordnance engineers made significant advances in the design of artillery materiel, particularly as the century drew to a close, the improvements tended to contribute to the efficiency of guns within the direct-fire concept of employment. As a result, the trench was no less of a problem in 1898 than it had been a generation earlier.

There was a tendency for artillerymen and ordnance designers to be swept up by technological momentum. The tendency showed itself in the enthusiasm that developed late in the century for small-caliber, low-trajectory, rapid-fire field guns. In effect, the paradigm of direct fire exploited technology in its own behalf. A period of protracted relative peace contributed to the tendency. Although the direct fire paradigm was challenged in the Russo-Turkish War of 1878, it was not overturned. In the subsequent decades of peace, the lessons of the conflict faded, and theory tended to replace the practical example of war. "Theory" refers to the perceived application of the new guns. The rafale is a tactical example--but one to which the American Army never entirely subscribed. On the other hand, important decisionmakers did believe that the rapidity of the new field pieces would permit a reduction in the ratio of guns to troops. This perception was given direction by the paradigm of direct fire; it was consistent with the relatively limited volume of fire associated with the paradigm. It stands in contrast to the great saturation bombardments that were common

under the paradigm of indirect fire. In effect, certain materiel advances tended to outrun the efficiency of the concept of their application. The advance of field artillery technology did two things; it responded to the demands of the direct-fire paradigm by providing light, low-trajectory, rapid-fire field guns; but at the same time, it helped to prepare the way for a new doctrine. However, a stimulus was needed to effect the shift.

The paradigm of direct fire was not affected by the conflicts in Cuba and South Africa at the end of the century. The duration of the first war was too short to provide a meaningful exercise of the paradigm. In addition, it ended in a celebrated victory--a situation that was not likely to provoke an analysis of tactical methods. The field artillery was criticized for its performance in the war, but the criticism took the form of assertions that gunners failed to aggressively provide direct-fire support; critics found fault, not with the method, but with its application. The conflict between America and Spain was closely followed by the Boer War in South Africa. American soldiers tended to perceive the combat in South Africa as an aberration, a colonial conflict worthy only of curiosity. As a result, little was learned from the war. Neither the experience in Cuba nor reports from South Africa challenged the domination of the direct-fire paradigm.

The war in Manchuria was of a different nature. Massed, well equipped armies closed with one another in protracted battle. The lethality of modern weaponry was felt as the infantry took to trenches and the artillery also sought cover. The war tested the direct-fire paradigm for the last time. As the efficiency of the old method faltered, the belligerents shifted to a system of indirect fire for

maneuver artillery. The advance of technology had provided all of the necessary ingredients to support the new system. The example set by the Japanese quickly produced a change in the American concept of field artillery employment. In effect, the Russo-Japanese War was the right war at the right time. Had that particular type of war occurred a few years earlier, the result might have been the same, because the necessary technology was available at the end of the 1890's.

The general growth of technology will eventually provide the resources necessary to allow the military planner to escape from the constraints of his current paradigm. Much of the technology that made indirect fire possible was progressively taken from a number of sources; most of which were initially unrelated to mobile artillery development. However, it took a test of war to force a recognition of the potential of available technology.

Thus far these conclusions have ignored the effect of personalities on the evolution of doctrine. The dominance of a paradigm, the thrust of technology, and the accidental test of war transcend man's ability at conscious manipulation.

Men, however, do play a role in the speed of technological change. For instance, there is a marked contrast between A. B. Dyer's conservative approach to artillery development and William Crozier's progressive efforts. Of course, in evaluating the actors, one must keep in mind that each man operated in a different environment. Threat perceptions, political considerations, and the availability of funds all changed with time. In addition, during the period of the study, there was a general improvement in that vaguely defined attribute "professionalism." All of these factors operated through the men

charged with responsibility for technological development to contribute to the rate of change.

Also, the rate of change was influenced by the nature of the decisionmaking process. The role of the Ordnance Department was predominant throughout the period of the study. The early preoccupation of the Department with coast artillery did much to delay certain advances in materiel for many years. Of course, preoccupation with coast defense was not unique to the Department; it was the product of a widely held threat perception. However, in the provision of heavy armament, the Department was determined to construct guns of its own design. The predilection added to the delay in certain areas of materiel development. Even when machinery was imposed on the ordnance organization to oversee the development process, as it was with the establishment of the Board of Ordnance and Fortification, the supervisors were ultimately at the mercy of the technicians; invariably the Department built cannons of its own design.

In the final analysis, there is little evidence that the process of materiel evolution would have been much different if soldiers outside of the Ordnance Department had exerted a greater influence in weapons development. In essence, all American officers were subject to the paradigm of direct fire. Increased participation by artillerymen in the design process might have accelerated certain technological achievements, but the indications are that the general direction of improvement would have been the same.

Men influenced at least the rate, if not the direction of materiel change; they also contributed to the speed of transition to the new paradigm. For instance, the initiative of the Chief of Artillery

John P. Story, accelerated organizational adjustments; William Crozier did the same for materiel; but perhaps President Theodore Roosevelt, with his direct interest in the status of the field artillery, provided the greatest impetus.

In summary, the process of evolution of field artillery doctrine was a complex phenomenon. The persistence of the prevailing paradigm, the general advance of technology, and the haphazard test of war were features that operated beyond the conscious control of men. However, men certainly were not left without a conscious role to play; they determined the rate of materiel development, and, in the end, they recognized and accepted the new paradigm.

It is not the intention of the author to apply the lessons of the study to the present or to the future in detail; however the following brief, general observations are offered for the reader's interest. The Army is experiencing the emergence of an anti-armor doctrine, currently called the "active defense" concept. It gives the appearance of being a shift in paradigms, similar in some respects to the earlier change in attitudes about field artillery employment. The growth of technology seems to have provided the necessary materiel, and the 1973 Mideast War seems to have provided the necessary example. But the phenomenon is too close to draw a definitive conclusion about the actuality of a paradigm shift; the passage of time will provide the necessary perspective. It is probable that a shift is indeed occurring. On the other hand, there is a chance that the current change is an advancement within the old battlefield concept, that the situation is more analogous to the period following the Franco-Prussian War than it is to the era that followed the conflict in Manchuria, and that a true shift

in paradigms is yet to come. In any event, it is certain that the technology necessary to support the next change, whenever it may come, is already gathering.

NOTES

CHAPTER I

¹David G. Chandler, The Campaigns of Napoleon (New York: Macmillan Company, 1966), pp. 362-363, 578-579.

²Ibid., pp. 358-359. Six hundred meters was a maximum range. Shorter ranges were more common. During the American Civil War gunners were instructed to begin the use of canister when the enemy was within 350 yards. William H. Frank, William F. Barry, and Henry J. Hunt, Instruction for Field Artillery (Washington, D.C.: Government Printing Office, 1864), p. 29.

³Chandler, Napoleon, p. 341.

⁴Ibid., p. 363.

⁵Fairfax Downey, Gannonade: Great Artillery Actions of History (Garden City, New York: Doubleday and Company, 1966), pp. 170-172.

⁶Dennis Hart Mahan, An Elementary Treatise on Advance-Guard, Out-Post and Detachment Service of Troops, and the Manner of Posting and Handling Them in Presence of an Enemy (New York: John Wiley, 1853), pp. 45-46.

⁷Warren Ripley, Artillery and Ammunition of the Civil War (New York: Promontory Press, 1970), p. 366. Guns were capable of higher elevations by the expedient of digging the carriage trail into the ground.

⁸Ibid., p. 368.

⁹Ibid., p. 367.

¹⁰Ibid., pp. 366-367.

¹¹Ibid.; and Janice E. McKenney, "Field Artillery" (draft manuscript for the Army Lineage Series, U.S. Army Center of Military History, Washington, D.C., 1972), p. 68.

¹²Russell F. Weigley, History of the United States Army (New York: The Macmillan Company, 1967), pp. 235-236.

¹³Claud E. Fuller, The Rifled Musket (New York: Bonanza Books, 1958), p. 2, reprint of a letter from Col. H. K. Craig, United States Ordnance Department, to Hon. J. Holt, Secretary of War, dated 21 January 1861.

¹⁴ Bruce Catton, The Army of the Potomac: Mr. Lincoln's Army (Garden City, New York: Doubleday and Company, 1951, 1962), p. 187, gives the rifle's effective range as ". . . 200 to 250 yards--'effective range' meaning the distance at which a defensive line of battle could count on hitting often enough to break up an attack by relatively equal numbers." J. F. C. Fuller, A Military History of the Western World, vol. 3 From the Seven Days Battle, 1862, to the Battle of Leyte Gulf, 1944 (n.p.: Minerva Press, 1967, paperback edition), p. 17, gives the effective range of the Civil War rifle as 500 yards without further qualification. Fuller, Rifled Musket, p. 5 says that the Model 1855 rifled musket was expedited to put 10 consecutive shots in a 27-inch bullseye at 500 yards. Claud Fuller's explanation is precise enough to validate rifle effectiveness at 500 yards.

¹⁵ Solid shot was simply a metal ball. Shell was a hollow metal sphere filled with explosive which was ignited by a burning time fuse. Case was like shell; but, in addition, it contained small metal balls that increased its effect against men and horses. Canister was simply a tin container filled with metal projectiles that yielded a shotgun effect from the cannon's mouth. Grape was similar to canister, but its projectiles were larger, and they were fewer in number. Since canister had a better anti-infantry effect, grape had been discontinued in the U.S. field artillery several years before the war, although it was still issued to the heavier siege and fortress guns, and to the Navy. L. Van Loan Naisawald, Grape and Canister: The Story of the Field Artillery of the Army of the Potomac, 1861-1865 (New York: Oxford University Press, 1960), p. 541. The author explains his title as poetic license.

¹⁶ Dennis Hart Mahan, A Complete Treatise on Field Fortification, With the General Outlines of the Principles Regulating the Arrangement, the Attack, and the Defence of Permanent Works (n.p.: originally published by Wiley and Long, 1836), reprint edition, by the West Point Military Library series (New York: Greenwood Press, 1968), pp. vii-viii.

¹⁷ See *Ibid.*, pp. 2-5.

¹⁸ Edward H. Hagerman, "The Evolution of Trench Warfare in the American Civil War" (Ph.D. dissertation Duke University, 1965), p. 26.

¹⁹ Douglas Southall Freeman, R. E. Lee, 3 vols. (New York: Charles Scribner's Sons, 1934), 3:204.

²⁰ William E. Birkhimer, Historical Sketch of the Organization, Administration, Materiel and Tactics of the Artillery, United States Army (Washington, D.C.: James J. Chapman, 1884), p. 266.

²¹ Ripley, Artillery and Ammunition, pp. 161-163. The 3-inch designation was a bore diameter that corresponded with that of a 6-pounder smoothbore. The older method of designating artillery size was based on the weight of a spherical, solid iron shot. The weight of elongated projectiles used in rifled artillery did not obey any geometric limitation, so the term "pounder" tended to yield to bore measurement as a means of designating the size of rifled artillery.

The 3-inch gun fired a shell that weighed 9 pounds. *Ibid.*, p. 374.

²²Naisawald, Grape and Canister, p. 37. The continued use of "pounder" with Parrott guns is a manifestation of the confusion that attends change. Initially, the weapon called the "10-pounder" had a bore diameter of 2.9 inches. This was changed to 3 inches in 1863. Other bore diameters were as follows:

20-pounder	3.67-inch
30-pounder	4.2-inch
60-pounder	5.3-inch
100-pounder	6.4-inch
200-pounder	8-inch
300-pounder	10-inch

²³Ripley, Artillery and Ammunition, p. 109.

²⁴Naisawald, Grape and Canister, p. 37.

²⁵Ripley, Artillery and Ammunition, pp. 370-371.

²⁶Naisawald, Grape and Canister, p. 37.

²⁷French, Instruction for Field Artillery, pp. 29-30.

²⁸Ripley, Artillery and Ammunition, pp. 124, 137, 162-163, 177.

²⁹*Ibid.*, pp. 366, 370, 372, 374. The Napoleon was named for Louis Napoleon who initiated the tests in 1850 that resulted in the development of the gun.

³⁰*Ibid.*

³¹McKenney, "Field Artillery," table 6; and A. F. L. V. de Marmot, The Spirit of Military Institutions, trans. Frank Schaller (Columbia, S.C.: Evans and Cogswell, 1864), p. 81.

³²Weigley, History, p. 237.

³³Elongated shot were occasionally used with smoothbores, but success was erratic. Ripley, Artillery and Ammunition, p. 271.

³⁴*Ibid.*, p. 28. Efforts to devise similar fuses for spherical projectiles met with only limited success. By 1850, it was known that the Belgians had devised one, the Splingard. It used a slow burning primer charge which was ignited when the piece was fired. The flame was contained in a light plaster tube which shattered on impact, igniting the bursting charge. *Ibid.*, p. 279.

³⁵Naisawald, Grape and Canister, p. 8.

³⁶Birkhimer, Historical Sketch, p. 79.

³⁷Vincent J. Esposito and John R. Elting, A Military History and Atlas of the Napoleonic Wars (New York: Frederick A. Praeger, 1964),

Introduction.

³⁸Chandler, Napoleon, p. 332.

³⁹Naisawald, Grape and Canister, p. 28. Barry was a capable artilleryman who had recently suffered embarrassment for his tragic misidentification of a host of oncoming Virginians at Bull Run. The two Union batteries that helped to put Brigadier General Banard E. Bee's brigade to flight, which led him to appeal to the vision of Jackson "standing like a stone wall," were enjoying considerable success until Barry commanded them not to fire on a rapidly closing force that he took to be Federals. The advancing Virginians were far less confused about who was friend and who was foe, and at seventy yards their musketry put an end to the effectiveness of the batteries. Fairfax Downey, Sound of the Guns: The Story of American Artillery from the Ancient and Honorable Company to the Atom Cannon and Guided Missile (New York: David McKay Company, 1956), p. 128.

⁴⁰U.S., War Department, War of the Rebellion: A Compilation of the Official Records of the Union and Confederate Armies, series 1, vol. 5 (Washington, D.C.: Government Printing Office, 1881), p. 67.

⁴¹Ibid.

⁴²Birkhimer, Historical Sketch, p. 81.

⁴³McKenney, "Field Artillery," pp. 71-72, 97-98.

⁴⁴Ibid., p. 85.

⁴⁵Ibid.

⁴⁶Naisawald, Grape and Canister, pp. 30, 33.

⁴⁷Ibid., p. 32.

⁴⁸Ibid. This was not an arbitrary ruling by Halleck. He wrote, ". . . artillery acts by batteries, . . ." in the 1846 edition of his book. The same appears in the 1859 edition. Henry Halleck, Elements of Military Art and Science: Or Course of Instruction in Strategy, Fortification, Tactics of Battles; Embracing the Duties of Staff, Infantry, Cavalry, Artillery, and Engineers (New York: D. Appleton and Company, 1859), p. 289.

⁴⁹Naisawald, Grape and Canister, p. 34.

⁵⁰Birkhimer, Historical Sketch, p. 81.

⁵¹Downey, Sound of the Guns, p. 129.

⁵²Naisawald, Grape and Canister, p. 123, 124.

⁵³Ibid., pp. 29, 131-135.

- ⁵⁴Downey, Sound of the Guns, p. 133.
- ⁵⁵Naisawald, Grape and Canister, pp. 131-135.
- ⁵⁶Downey, Cannonade, p. 191.
- ⁵⁷Naisawald, Grape and Canister, p. 135.
- ⁵⁸U.S., War Department, War of the Rebellion: A Compilation of the Official Records of the Union and Confederate Armies, series 1, vol. 11, pt. 2 (Washington, D.C.: Government Printing Office, 1881), p. 241.
- ⁵⁹Naisawald, Grape and Canister, pp. 146-150.
- ⁶⁰Ibid., pp. 28, 182.
- ⁶¹Birkhimer, Historical Sketch, p. 98.
- ⁶²Naisawald, Grape and Canister, pp. 181-182.
- ⁶³Jennings Cropper Wise, The Long Arm of Lee: The History of the Artillery of the Army of Northern Virginia, with a Foreword by L. Van Loan Naisawald (New York: Oxford University Press, 1959), pp. 277, 279.
- ⁶⁴U.S., War Department, War of the Rebellion: A Compilation of the Official Records of the Union and Confederate Armies, series 1, vol. 25, pt. 2 (Washington, D.C.: Government Printing Office, n.d.), p. 651. The law authorized field grade officers at a rate of a major for every sixteen guns; a lieutenant colonel for every twenty-four guns, and a colonel for every forty guns.
- ⁶⁵Downey, Sound of the Guns, p. 142.
- ⁶⁶Naisawald, Grape and Canister, pp. 183, 187, 189, 228.
- ⁶⁷Ibid., pp. 214-215.
- ⁶⁸Ibid., pp. 229-230.
- ⁶⁹Birkhimer, Historical Sketch, p. 99.
- ⁷⁰Ibid., p. 83.
- ⁷¹Naisawald, Grape and Canister, pp. 236-237, 239-244.
- ⁷²Ibid., p. 83.
- ⁷³Douglas Southall Freeman, Lee's Lieutenants, vol 2: Cedar Mountains to Chancellorsville (New York: Charles Scribners Sons, 1942, 1971), p. 349.
- ⁷⁴Downey, Sound of the Guns, p. 143.

- 75Freeman, Lee's Lieutenants, 2:349-350.
- 76Freeman, R. E. Lee, 2:490-491.
- 77Hagerman, "Trench Warfare", pp. 170, 254.
- 78Freeman, R. E. Lee, 2:491-494.
- 79Ibid., 2:540.
- 80Naisawald, Grape and Canister, p. 310.
- 81Ibid., pp. 329-330.
- 82Birkhimer, Historical Sketch, pp. 84, 86, 90-91.
- 83U.S., War Department, Annual Reports of the War Department for the Fiscal Year Ended June 30, 1904 (Washington, D.C.: Government Printing Office, 1904), vols. 1-4, p. 419.
- 84Birkhimer, Historical Sketch, p. 85.
- 85Naisawald, Grape and Canister, p. 330. Hunt's brigades averaged five batteries. At four batteries, the Confederate battalions were but one less.
- 86U.S., War Department, War of the Rebellion: A Compilation of the Official Records of the Union and Confederate Armies, series 1, vol. 27, pt. 2 (Washington, D.C.: Government Printing Office, 1889), p. 346.
- 87Birkhimer, Historical Sketch, pp. 104-105.
- 88Wise, The Long Arm, p. 556.
- 89Naisawald, Grape and Canister, pp. 416-417, 420, 427-431.
- 90Freeman, R. E. Lee, 3:204.
- 91Naisawald, Grape and Canister, p. 463-465.
- 92U.S., War Department, War of the Rebellion: A Compilation of the Official Records of the Union and Confederate Armies, series 1, vol. 36, pt. 1 (Washington, D.C.: Government Printing Office, 1891), p. 286.
- 93Naisawald, Grape and Canister, p. 477.
- 94War Department, War of the Rebellion, series 1, vol. 36, pt. 1, pp. 527-528.
- 95Naisawald, Grape and Canister, p. 500.
- 96Ibid., p. 287.
- 97Ulysses S. Grant, Personal Memoirs of U. S. Grant (New York:

Charles L. Webster and Company, 1886), vol. 2, p. 241.

⁹⁸War Department, War of the Rebellion, series, 1, vol. 36, pt. 1, p. 288.

⁹⁹Hagerman, "Trench Warfare," pp. 394-395.

¹⁰⁰Freeman, R. E. Lee, 3:389.

¹⁰¹"Siege Artillery at Petersburg" [sic], Army and Navy Journal, 30 September 1865, p. 83.

¹⁰²Hagerman, "Trench Warfare," p. 401.

¹⁰³Naisawald, Grape and Canister, p. 508.

¹⁰⁴During the Petersburg campaign, the U.S. Army for the first time used spherical case in addition to the traditional shell in heavy mortars. "Siege Artillery," Journal, p. 83.

¹⁰⁵Naisawald, Grape and Canister, p. 514-519.

NOTES

CHAPTER II

¹Freeman, R. E. Lee, 3:463.

²"French Study of Artillery," Army and Navy Journal, 29 April 1865, p. 586.

³Chandler, Napoleon, p. 357.

⁴The figures are calculated from data contained in Marshal Marmont, The Spirit of Military Institutions, trans. Frank Schaller (Columbia, S.C.: Evans and Cogswell, 1864), p. 81.

⁵Instruction for Heavy Artillery: Prepared by a Board of Officers for the Use of the Army of the United States (Charleston, S.C.: Evans and Cogswell, 1861), pp. 85-88.

⁶Ibid., pp. 89-91.

⁷Margaret Masterman determined that Kuhn had used the term "paradigm" in 21 different contexts. Margaret Masterman, "The Nature of a Paradigm" in Criticism and the Growth of Knowledge, ed. by Imre La Katos and Alan Musgrove (Cambridge, England: Cambridge University Press, 1970), pp. 61-65. In order to clear the confusion, he redefined "paradigm" in the postscript of the revised edition by substituting "disciplinary matrix" for some of his contextual uses of "paradigm" and relegating "paradigm" itself to one element in the disciplinary matrix. Actually, because of the confusion attending the use of the word "paradigm," he substituted the term "exemplar" for the element of the matrix. An exemplar is a piece of scientific knowledge that is both basic and common to a particular scientific discipline. Thomas S. Kuhn, The Structure of Scientific Revolution (Chicago: University of Chicago Press, 1970), pp. 181, 182, 186, 187. The difficulty with his redefinition of the term "paradigm" is that the change is not effectively carried into the text of the second edition; usage in a variety of contexts continues to plague the reader.

⁸Kuhn, Revolution, p. viii.

⁹Actually, it can be either a theory or a fact.

¹⁰Kuhn, Revolution, p. 77.

¹¹Ibid., pp. 84-85.

¹²Ibid.

¹³Ibid., p. 208.

¹⁴Modern science increasingly is experiencing some of the encumbrances of military doctrine. Government allocation of funds to provide the vast sums demanded by modern research will influence development much the same as it influences the development of military doctrine. Kuhn gives no hint as to how this might affect his scientific paradigm.

¹⁵Of course, each of these manifestations also can be thought of as either a concept or a body of concepts; and each can be analyzed in much the same way as the direct-fire paradigm; although it is not the intent of this paper to do so. However, should one make such an attempt, he must keep in mind as he proceeds up, down, or across the scale of ideas, that with a different set of facts this approach may fail in one or more of its particulars. Like any model it should not be allowed to drive the facts.

NOTES

CHAPTER III

¹Weigley, History, p. 266.

²McKenney, "Field Artillery," p. 119, Table 7.

³U.S., War Department, General Orders Number 144, 9 October 1865. With the exception of Fort Monroe and the Keys, the coast of the South was defended by black soldiers under regional department commanders.

⁴U.S., War Department, General Orders Number 151, 16 October 1865.

⁵U.S., War Department, General Orders Number 6, 30 January 1866.

⁶Ibid.

⁷Ibid. Like many officers Hunt reverted to his Regular Army rank at the end of the war. However, it was common for veterans to use their brevet titles, particularly in correspondence.

⁸The Artillery was not unique in being without a chief; neither the Infantry nor the Cavalry had one.

⁹Birkhimer, Historical Sketch, pp. 124, 125.

¹⁰For several years, the Artillery was the only branch to have its own instructional institution. The School of Application for Infantry and Cavalry at Fort Leavenworth was not established until 1881.

¹¹U.S., War Department, General Orders Number 99, 13 November 1867.

¹²U.S., Congress, House, Report of the Secretary of War, Ex. Doc. 1, 42d Cong., 2d sess., 1871, pt. 2, 1:81.

¹³War Department, General Orders Number 99, 13 November 1867.

¹⁴Congress, Report of the Secretary of War, Ex. Doc. 1, 42d Cong., 2d sess., 1871 pt. 2, 1:79-81.

¹⁵In 1877 the Artillery School published its first manuals. The titles are indicative of the technical and professional nature of the material. The four initial works were: Service and Description of

Getling Guns; Mechanical Maneuvers with 13-inch Sea-Coast Mortar; Description and Use of Dyer's Method of Pointing Mortars; and Notes on Gun-Cotton and Other Explosives. See Checklist of United States Public Documents 1789-1909, 3d ed, vol 1 (Washington; D.C.: Government Printing Office, 1911; reprint ed., New York: Kraus Reprint Corporation, 1967), pp. 1311-1312.

¹⁶See House, Report of the Secretary of War, Ex. Doc. 1, 42d Cong, 2d sess., 1871, pt. 2, 1:79-81.

¹⁷Birkhimer, Historical Sketch, p. 138-139.

¹⁸U.S., War Department, General Orders Number 6, 18 February 1869

¹⁹U.S., War Department, General Orders Number 101, 26 November 1867.

²⁰House, Report of the Secretary of War, Ex. Doc. 1, 42d Cong., 2d sess., 1871, pt. 2, 1:82.

²¹Birkhimer, Historical Sketch, pp. 186-187.

²²For instance, see Halleck, Elements of Military Art and Science

²³Artillery Tactics United States Army, Assimilated to the Tactics of Infantry and Cavalry (New York: D. Appleton and Company, 1874), p. 52.

²⁴U.S., Department of the Army, Combat Operations Research Group (CORG), Evolution of the United States Army Field Manual, by Virgil Ney, CORG-M-244 (memorandum for Headquarters United States Army Combat Developments Command, 1966), p. 51.

²⁵U.S., War Department, Official Army Register for January, 1879 (Washington, D.C.: Adjutant General's Office, 1879), p. 136.

²⁶Combat Operations Research Group, Evolution of the Field Manual, pp. 43-44.

²⁷U.S., War Department, General Orders Number 73, 1 August 1867.

²⁸"Proceedings of a Board to devise and report upon a system of 'Artillery Tactics,' 1868" Letters Received by the Adjutant General's Office, 1801-70, Microcopy No. M-619, Roll No. 681, Old Military Records Division, Record Group 94, Records of the Adjutant General's Office 1780's-1917, National Archives, Washington, D.C. Hereafter referred to as "Proceedings of a Board, 1868."

²⁹U.S., War Department, General Orders Number 69, 6 August 1869.

³⁰"Proceedings of a Board, 1868," passim. The board used the "grand battery" interchangeably with "battalion"--a holdover from Napoleonic usage.

31 "Schofield Board Report," and related material, Letters Received by the Adjutant General's Office, 1801-70, Microcopy No. M-619, Roll No. 682, Old Military Records Division, Record Group 94, Records of the Adjutant General's Office, 1780's-1917, National Archives, Washington, D.C.

NOTES

CHAPTER IV

¹U.S., War Department, Message of the President of the United States, and Accompanying Documents, Ex. Doc. No. 1, 39th Cong., 1st sess, 1866, p. 995.

²The Army Almanac: A Book of Facts Concerning the Army of the United States (Washington, D.C.: Government Printing Office, 1950), pp. 34, 114. The board of War and Ordnance was the forerunner of the Department of War, which was established by the Act of August 7, 1789. Ibid., p. 34.

³U.S., War Department, Ordnance Department, The Ordnance Department as a Portion of the United States Military Establishment: Being a Historical Statement of the Rise and Progress of the Ordnance Department, Secretary of War, and Army Proper (Washington, D.C.: n.p., 1876), pp. 38, 39, 43, 44, 78, 79.

⁴Ibid., p. 81.

⁵Maurice Matloff, ed., American Military History (Washington, D.C.: Office of the Chief of Military History, 1969, partially revised 1973), p. 291.

⁶Weigley, History, p. 285.

⁷U.S., Congress, House, Report of the Secretary of War, Ex. Doc. 1, 41st Cong., 2d sess., 1869, pt. 2, 1:444.

⁸Theophilos F. Rodenbough and William L. Haskin, eds., The Army of the United States: Historical Sketches of Staff and Line with Portraits of Generals-in-Chief (New York: Arno Press, 1966, first published 1896), p. 129.

⁹Weigley, History, p. 238.

¹⁰Rodenbough, Army of the United States, p. 133.

¹¹U.S., War Department, Official Army Register for January, 1870 (Washington, D.C.: Adjutant General's Office, 1870), p. 3.

¹²U.S., Congress, Senate, Report, Rep. Com. No. 173, 40th Cong., 2d sess., 1868, p. 13.

¹³The committee was dominated by antislavery Republicans. It

is known best for its investigations of officers of conservative and Democratic political views who were thought to be unwilling to conduct a harsh war against the South. See Weigley, History, p. 255.

¹⁴U.S., Congress, Senate, Report, Rep. Com. No. 121, 38th Cong., 2d sess., 1865, p. 1.

¹⁵U.S., Congress, Senate, Report, Rep. Com. No. 266, 40th Cong., 3d sess., 1869, p. 217.

¹⁶Senate, Report, Rep. Com. No. 121, 38th Cong., 2d sess., 1865, pp. 3, 171, 172.

¹⁷Senate, Report, Rep. Com. No. 266, 40th Cong., 3d sess., 1869, p. 42.

¹⁸Senate, Report, Rep. Com. No. 121, 38th Cong., 2d sess., 1865, p. 139.

¹⁹Ibid., p. 140, 141. Parrott felt that the shock of the exploding propelling charge caused a detonating friction between the inner wall of the shell and the powder that it contained. Well before his congressional appearance, to correct the deficiency, he had begun to coat the inner walls with a melted mixture of rosin, tallow, and brown soap. Ibid., pp. 141-142.

²⁰Ibid., p. 105.

²¹Ibid., pp. 40, 139. The West Point Foundry was not associated with the Military Academy. It was a civilian concern located at Cold Springs, New York.

²²U.S., War Department, United States Artillery School, "Changes Wrought in Artillery in the Nineteenth Century, and their Effect Upon the Attack and Defense of Fortified Places," Essay by Lieutenant Henry R. Lemly (Fort Monroe, Virginia: The Artillery School, 1886), p. 5.

²³U.S., War Department, Ordnance Department, A Collection of Ordnance Reports and Other Important Papers Relating to the Ordnance Department. (Washington, D.C.: Government Printing Office, 1890), 3:229-230.

²⁴Senate, Report, Rep. Com. No. 121, 38th Cong., 2d sess., 1865, p. 98.

²⁵Ibid., pp. 98-99.

²⁶Ibid., pp. 7-8, 44-45, 99.

²⁷Ripley, Artillery and Ammunition, p. 109.

²⁸Senate, Report, Rep. Com. No. 121, 38th Cong., 2d sess., 1865, pp. 11, 141, 146.

²⁹Ibid., pp. 5, 6.

³⁰U.S., War Department, General Orders Number 51, 15 May 1869, p. 15.

³¹Senate, Report, Rep. Com. No. 121, 38th Cong., 2d sess., 1865, pp. 2, 6. During the war, the Army rifled many of its old cast-iron smoothbores, the 12-, 18-, 24-, 32-, and 42-pounders (see table 1). But it was a stopgap measure pending the development of better weapons. Ripley, Artillery and Ammunition, p. 17.

³²Frank E. Comparato, Age of Great Guns: Cannon Kings and Cannoneers Who Forged the Firepower of Artillery (Harrisburg, Pa.: Stackpole Company, 1965), p. 199.

³³Senate, Report, Rep. Com. No. 121, 38th Cong., 2d sess., 1865, p. 132.

³⁴Roy P. Basler, ed., The Collected Works of Abraham Lincoln, 8 vols. (New Brunswick, New Jersey: Rutgers University Press, 1953), 6:484-485.

³⁵Ibid., p. 485. The date of the memo is uncertain, but the editor has assigned to it the same date as the order to Ames, 28 September 1863.

³⁶Senate, Report, Rep. Com. No. 121, 38th Cong., 2d sess., 1865, p. 40.

³⁷Ibid., p. 133.

³⁸Ibid., p. 152.

³⁹Ibid., pp. 5, 133.

⁴⁰House, Message of the President, Ex. Doc. No. 1, 39th Cong., 1st sess., 1866, p. 994. The underlining is mine.

⁴¹Ibid., pp. 995-996.

⁴²Ibid., p. 995. This was apparently done with funds already appropriated.

⁴³Ibid.

⁴⁴U.S., Congress, House, Report of the Secretary of War, Ex. Doc. No. 1, 46th Cong., 3d sess., 1880, pt. 2, 3:xiii.

⁴⁵Artillery Tactics, p. 409, gives a date of 1870 for the adoption effort. Birkhimer, Historical Sketch, p. 294, gives a date of 1868. The Ordnance Department, engrossed with heavy artillery, failed to mention the 3.5-inch gun effort in its annual reports.

⁴⁶Senate, Report, Rep. Com. No. 121, 38th Cong., 2d sess., 1865,

p. 50.

⁴⁷Ibid., p. 46. A battery of six 10-pounder Whitworths had been given to the Union Army by Americans abroad. They were little used. Ibid., pp. 47-48.

⁴⁸U.S., Congress, House, Report of the Secretary of War, Ex. Doc. No. 1, 41st Cong., 2d sess., 1869, pt. 2, 1:32.

⁴⁹Senate, Report, Rep. Com. No. 121, 38th Cong., 2d sess., 1865, pp. 39. A straight comparison of the fractions can be misleading. At the same caliber and type, an elongated projectile would weigh more than a spherical one. But the fractions do give some idea of the difference in charges.

⁵⁰Comparato, Great Guns, pp. 58, 75, 76.

⁵¹Senate, Report, Rep. Com. No. 121, 38th Cong., 2d sess., 1865, p. 176. In addition to his work with powder, in 1861, Rodman had developed a "crusher" gage which permitted, for the first time, the measurement of pressure inside a cannon's bore. Comparato, Great Guns, p. 73.

⁵²Ibid., p. 149.

⁵³House, Message of the President, Ex. Doc. No. 1, 39th Cong., 1st sess., 1866, p. 995.

⁵⁴U.S., War Department, Ordnance Department, Gun Making in the United States, by Rogers Birnie (Washington, D.C.: Government Printing Office, 1907), pp. 14-15. (reprinted from the Journal of the Military Service Institution from a paper prepared in 1887.)

⁵⁵U.S., Congress, House, Message of the President of the United States and Accompanying Documents, Ex. Doc. No. 1, 40th Cong., 3d sess., 1867, p. 611.

⁵⁶Artillery School essay, "Changes Wrought in Artillery," p. 6.

⁵⁷House, Message of the President, Ex. Doc. No. 1, 40th Cong., 2d sess., 1867, p. 611.

⁵⁸U.S., Congress, House, Message of the President of the United States and Accompanying Documents, Ex. Doc. No. 1, 40th Cong., 3d sess., 1868, p. 992.

⁵⁹Senate, Report, Rep. Com. No. 121, 38th Cong., 2d sess., 1865, pp. 12, 39. The reasons for the low muzzle velocity of rifled projectiles were greater bore resistance and projectile weight, and a smaller propelling charge.

⁶⁰Artillery School essay, "Changes Wrought in Artillery," pp. 5, 6.

⁶¹U.S., Congress, Senate, Report, Rep. Com. No. 165, 39th Cong.,

2d sess., 1867, pp. 12, 13.

⁶²The Chief of Ordnance continued to press his case; however, it was seven years before the Congressmen gave it favorable action. U.S., Congress, House, Report, Rep. No. 78, 43d Cong., 1st sess., 1874, p. 1; and U.S., Congress, Senate, Report, Rep. No. 166, 43d Cong., 1st sess., 1874, p. 1.

⁶³Senate, Report, Rep. Com. No. 165, 39th Cong., 2d sess., 1867, pp. 1-4.

⁶⁴James G. Blaine, Twenty Years of Congress: From Lincoln to Garfield (Norwich, Connecticut: Henry Bill Publishing Company, 1886), 2:296.

⁶⁵U.S., Congress, Senate, Report, Rep. Com. No. 173, 40th Cong., 2d sess., 1868, p. 1.

⁶⁶Ibid., p. 21.

⁶⁷Ibid., p. 6.

⁶⁸Ibid., pp. 6, 9.

⁶⁹See War Department, General Orders Number 51, 15 May 1869, p. 3.

⁷⁰Senate, Report, Rep. Com. No. 173, 40th Cong., 2d sess., 1868, pp. 18-19.

⁷¹Ibid., pp. 15-16.

⁷²War Department, General Orders Number 51, 15 May 1869, pp. 4-5.

⁷³Senate, Report, Rep. Com. No. 173, 40th Cong., 2d sess., 1868, pp. 18-19.

⁷⁴Ibid., pp. 12-13.

⁷⁵Basler, Works of Lincoln, 7:229, 236-237.

⁷⁶Ibid., 7:216n.

⁷⁷Stanton so testified to a subsequent military court of inquiry. War Department, General Orders Number 51, 15 May 1869, pp. 5-6.

⁷⁸U.S., Congress, Senate, "Letter of the Secretary of War," Ex. Doc. No. 81, 40th Cong., 2d sess., 1868, p. 1.

⁷⁹War Department, General Orders Number 51, 15 May 1869, p. 1.

⁸⁰Senate, Report, Rep. Com. No. 266, 40th Cong., 3d sess., 1869, pp. 53-54.

⁸¹Ibid., pp. 57, 63.

- ⁸²Ibid., pp. 56-57.
- ⁸³House, Message of the President, Ex. Doc. No. 1, 40th Cong., 2d sess., 1867, p. 611.
- ⁸⁴Senate, Report, Rep. Com. No. 266, 40th Cong., 3d sess., 1869, p. 55.
- ⁸⁵Ibid., pp. 9-10.
- ⁸⁶Ibid., pp. 32, 36.
- ⁸⁷See Ibid., p. 15.
- ⁸⁸Ibid., pp. 38-39.
- ⁸⁹Ibid., p. 2.
- ⁹⁰Ibid.
- ⁹¹Ibid., p. 4.
- ⁹²Ibid.
- ⁹³Ibid.
- ⁹⁴Ibid., p. 6.
- ⁹⁵Ibid.
- ⁹⁶Ibid., pp. 6-7.
- ⁹⁷Ibid., p. 5.
- ⁹⁸War Department, General Orders Number 51, 15 May 1869, pp. 1, 3
- ⁹⁹Quoted in Comparato, Great Guns, p. 201.
- ¹⁰⁰War Department, General Orders Number 51, 15 May 1869, pp. 16-17.
- ¹⁰¹House, Report of the Secretary of War, Ex. Doc. 1, 41st Cong., 2d sess., pt. 2, 1869, 1:32, 445.
- ¹⁰²A Collection of Ordnance Reports, 3:286.
- ¹⁰³House, Report of the Secretary of War, Ex. Doc. 1, 41st Cong., 2d sess., pt. 2, 1869, 1:33.
- ¹⁰⁴Ibid., pp. 447-448.
- ¹⁰⁵Ibid., p. 448.
- ¹⁰⁶U.S., Congress, House, Report of the Secretary of War, Ex. Doc.

No. 1, 41st Cong., 3d sess., pt. 2, 1870, 1:292-293. The 1867 report called for 805 smoothbores rather than 810 cited in the above document. House, Message of the President, Ex. Doc. No. 1, 40th Cong., 2d sess., 1867, p. 611.

¹⁰⁷House, Report of the Secretary of War, Ex. Doc. 1, 41st Cong., 2d sess., pt. 2, 1869, 1:444.

NOTES

CHAPTER V

¹U.S., Congress, House, "Letter of the Secretary of War," Ex. Doc. No. 56, 41st Cong., 3d sess., 1871, p. 1.

²Comparato, Great Guns, p. 198. The terms "brass" and "bronze" were often used interchangeably in American literature on artillery during the Nineteenth Century, with little regard for fine distinctions in the compositions of the two alloys.

³House, "Letter of the Secretary of War," Ex. Doc. No. 56, 41st Cong., 3d sess., 1871, pp. 1-2.

⁴Ibid., p. 1.

⁵U.S., Congress, House, Report of the Secretary of War, Ex. Doc. No. 1, 42d Cong., 2d sess., 1871, pt. 2, 1:255.

⁶Birchimer, Historical Sketch, p. 105.

⁷"Artillery Grand Tactics," Army and Navy Journal, 20 May 1876, p. 662.

⁸"French and German Artillery," Army and Navy Journal, 24 September 1870, p. 86; and Army and Navy Journal, 29 October 1870, p. 1.

⁹Army and Navy Journal, 19 November 1870, p. 218.

¹⁰Michael Howard, The Franco-Prussian War, (n.p.: Macmillan Company, Collier Books, 1969, first copyright 1961), pp. 5-6, 35-36, 96n.

¹¹"French and German Artillery," Journal, 24 September 1870, p. 86.

¹²Birchimer, Historical Sketch, p. 105.

¹³Ibid., p. 105-106.

¹⁴Howard, The Franco-Prussian War, p. 7. Howard sees a more complete reason for German success in the failure of the French to stay abreast of a general military revolution. p. 1.

¹⁵Ibid., p. 7.

¹⁶Tom Wintringham and J. N. Blashford-Snell, Weapons and Tactics (Baltimore: Penguin Books, part 1 1943, part 2 1973), p. 146.

275. ¹⁷For instance, see Howard, The Franco-Prussian War, p. 167,
- ¹⁸Fuller, From Seven Days to Layte Gulf, p. 133.
- ¹⁹Army and Navy Journal, 12 September 1879, p. 72.
- ²⁰"Rapid Field Entrenchments," Army and Navy Journal, 11 July 1874, p. 766. During the Civil War, digging emplacements for units had been carried in supply wagons. Hagerman, "Trench Warfare," p. 373.
- ²¹Army and Navy Journal, 8 April 1876, p. 571. Four feet of well-rammed snow would stop a bullet, but it took over fifteen feet to neutralize the effect of an artillery shell.
- ²²U.S., Congress, Senate, "Resolution," Mis. Doc. No. 73, 42d Cong., 2d sess., 1872, pp. 1-2.
- ²³See U.S., Congress, Senate, Report, Report No. 183, 42d Cong., 2d sess., 1872; and U.S., Congress, House, Report, Report No. 46, 42d Cong., 2d sess., 1872.
- ²⁴U.S., Congress, House, "Letter from the Secretary of War," Ex. Doc. No. 89, 42d Cong., 2d sess., 1872, p. 1.
- ²⁵See House, Report, Report No. 46, 42d Cong., 2d sess., 1872.
- ²⁶House, "Letter from the Secretary of War," Ex. Doc. No. 89, 42d Cong., 2d sess., 1872, p. 2.
- ²⁷House, Report, Report No. 46, 42d Cong., 2d sess., 1872, pp. 7, 14.
- ²⁸Ibid., p. 106. The amount of surplus war materiel sold between October 1870 and the end of the war in May 1871 was well above what was normally sold during an eight month period. The obvious conclusion was that the materiel was going to France. See, U.S., Congress House, "Letter of the Secretary of War," Ex. Doc. No. 89, 42d Cong., 2d sess., 1872, for a list of materiel sold.
- ²⁹U.S., Congress, House, "Views of the Minority," Report No. 46, 42d Cong., 2d sess., 1872, pt. 2, p. 4.
- ³⁰House, Report, Report No. 46, 42d Cong., 2d sess., 1872, p. 7.
- ³¹Senate, Report, Report No. 183, 42d Cong., 2d sess., 1872, pp. xx-xxi, xxiii, xxv.
- ³²Ibid., p. xxv.
- ³³Kenneth M. Stamp, The Era of Reconstruction, 1865-1877 (New York: Vintage Books, Random House, 1965), p. 189.
- ³⁴Allan Nevins, Hamilton Fish: The Inner History of the Grant

Administration (New York: Dodd, Mead and Company, 1936), pp. 460-462.

³⁵Senate, Report, Report No. 183, 42d Cong., 2d sess., 1872, p. xxv.

³⁶He did not return to the Senate when the Forty-Second Congress opened in March 1871. See Blaine, Twenty Years of Congress, 2:503, 692, 295.

³⁷House, Report, Report No. 46, 42d Cong., 2d sess., 1872, p. 12.

³⁸Ibid., pp. 10-11.

³⁹Senate, Report, Report No. 183, 42d Cong., 2d sess., 1872, p. 664.

⁴⁰U.S., Congress, House, Report of the Secretary of War, Ex. Doc. No. 1, 42d Cong., 3d sess., 1872, pt. 2, 1:326.

⁴¹Comparato, Great Guns, pp. 24-25.

⁴²House, Report of the Secretary of War, Ex. Doc. No. 1, 42d Cong., 3d sess., 1872, pt. 2, 1:326.

⁴³Ibid., p. 340.

⁴⁴U.S., Congress, House, Report of the Secretary of War, Ex. Doc. No. 1, 44th Cong., 1st sess., 1875, pt. 2, 3:97.

⁴⁵House, Report of the Secretary of War, Ex. Doc. No. 1, 42d Cong 3d sess., 1872, pt. 2, 1:315.

⁴⁶Collection of Ordnance Reports, 3:284, 286.

⁴⁷House, Report of the Secretary of War, Ex. Doc. No. 1, 43d. Cong., 1st sess., 1873, pt. 2, 1:7.

⁴⁸Birnie, Gun Making, pp. 20-21.

⁴⁹Jobe, Guns, p. 140.

⁵⁰Ibid.

⁵¹Comparato, Great Guns, pp. 25-26. Krupp entered the steel business in 1810 as a result of Napoleon's desire for a continental producer of British crucible steel.

⁵²Comparato, Great Guns, p. 209.

⁵³U.S., War Department, Artillery School, Essays of the Department of Artillery, "Steel as a Gun Metal," by Adam Slaker (Fort Monroe, Virginia: Artillery School Press, 1892), p. 19. Even as late as the 1890's, steel metallurgy was still something of a new science.

- ⁵⁴Comparato, Great Guns, p. 209.
- ⁵⁵U.S., Congress, House, "Letter from the Secretary of War," Ex. Doc. No. 17, 41st Cong., 2d sess., 1869, p. 5.
- ⁵⁶See Comparato, Great Guns, pp. 34-35.
- ⁵⁷House, Report of the Secretary of War, Ex. Doc. No. 1, 42d Cong., 2d sess., 1871, pt. 2, 1:256. The 14-pound charge for the 10-inch gun had been increased to 20 pounds, and the propellant for the 15-inch piece had been raised from 60 pounds to 100.
- ⁵⁸U.S., Congress, House, Report of the Secretary of War, Ex. Doc. No. 1, 43d Cong., 1st sess., 1878, pt. 2, 3:9.
- ⁵⁹Ibid., 3:445.
- ⁶⁰Ibid., 3:9.
- ⁶¹Ibid., 3:457-458.
- ⁶²Ibid., 3:458.
- ⁶³Ibid., 3:457. Civilians submitted thirteen proposals.
- ⁶⁴House, Report of the Secretary of War, Ex. Doc. No. 1, 43d Cong., 1st sess., 1873, pt. 2, 1:7.
- ⁶⁵Ibid.
- ⁶⁶Ibid.
- ⁶⁷U.S., War Department, Ordnance Office, Ordnance Notes, Nos. 1-40 (Washington, D.C.: n.p., n.d.), No. xxx, p. 187.
- ⁶⁸House, Report of the Secretary of War, Ex. Doc. No. 1, 43d Cong., 1st sess., 1873, pt. 2, 1:7.
- ⁶⁹Ibid., 1:6.
- ⁷⁰Nevins, Hamilton Fish, p. 542.
- ⁷¹Ibid., p. 675.
- ⁷²U.S., Congress, House, Report of the Committee on Military Affairs, Report No. 384, 43d Cong., 1st sess., 1874, p. 11.
- ⁷³Ibid., p. 12.
- ⁷⁴Ibid., p. 24.
- ⁷⁵Ibid., p. 25.
- ⁷⁶U.S., War Department, General Orders Number 46, 15 June 1872.

⁷⁷U.S., Congress, House, Report of the Secretary of War, Ex. Doc. No. 1, 44th Cong., 2d sess., 1876, pt. 2, 3:89.

⁷⁸House, Report of the Secretary of War, Ex. Doc. No. 1, 43d Cong., 1st sess., 1873, pt. 2, 1:10.

⁷⁹See Birnie, Gun Making, p. 24-25.

⁸⁰Army and Navy Journal, 29 November 1873, p. 245. Initial American interest in the French development was shown by the Navy rather than the Army.

⁸¹"The Shielded Gatling," Army and Navy Journal, 29 November 1873, p. 254.

⁸²"Smokeless Gunpowder," Army and Navy Journal, 26 October 1872, p. 174.

⁸³See U.S., Congress, House, Report, Report No. 74, 42d Cong., 3d sess., 1873.

⁸⁴Ibid., passim.

⁸⁵Ibid., pp. 3, 46-48, 51-53, 55-58, 139, 289.

⁸⁶Ibid., p. 102-106.

⁸⁷See "A Few Thoughts on the Artillery," Army and Navy Journal, 9 September 1871, p. 68. Later, the author was generally thought to be Major Charles H. Morgan (brevet brigadier general). For example, see "The Ordnance and Artillery," Army and Navy Journal, 16 September 1871, p. 78.

⁸⁸"A Few Thoughts on the Artillery," Journal, 9 September 1871, p. 68.

⁸⁹Ibid., p. 67.

⁹⁰Ibid..

⁹¹Ibid., p. 65.

⁹²Ibid., pp. 65-66.

⁹³Ibid., p. 66.

⁹⁴Ibid.

⁹⁵"A Few Thoughts on Artillery," Army and Navy Journal, 15 July 1871, p. 768.

⁹⁶U.S., War Department, Ordnance Office, Ordnance Notes, Nos. 68 to 100, No. LXVIII, pp. 534, 536.

⁹⁷See, "Few Thoughts on the Artillery," Journal, 9 September 1871, p. 67.

⁹⁸House, Report, Report No. 74, 42d Cong., 3d sess., 1873, pp. 289, 293. This is the breakdown of rank by branch:

	<u>Ordnance</u>	<u>Artillery</u>
Colonels	3	5
Lieutenant Colonels	4	3
Majors	10	15
Captains	20	60
First Lieutenant	16	130
Second Lieutenant	10	65

⁹⁹Ibid., p. 213.

¹⁰⁰Ibid., pp. 35-38, 277.

¹⁰¹Rodenbough, The Army of the United States, p. 135.

¹⁰²House, Report of the Committee on Military Affairs, Report No. 384, 43d Cong., 1st sess., 1874, p. 3.

¹⁰³House, Report, Report No. 74, 42d Cong., 3d sess., 1873, *passim*.

¹⁰⁴Ibid., pp. 213, 279. In 1869, when Grant became President and Sherman took his place as Commanding General of the Army, Grant promised Sherman that he would have authority over the staff agencies. The War Department issued orders to that effect, General Orders Number 11, 8 March 1869. But Grant reneged, and General Order Number 11 was rescinded only three weeks after it was issued. Weigley, History, p. 286; U.S., War Department, General Orders Number 28, 27 March 1869.

¹⁰⁵House, Report, Report No. 74, 42d Cong., 3d sess., 1873, p. x.

¹⁰⁶Rodenbough, The Army of the United States, p. 135.

¹⁰⁷Artillery Tactics, 1874, p. 410.

¹⁰⁸Ibid., pp. 409, 432, 441-442, 523.

¹⁰⁹Ibid., pp. 405-406, 409. Light batteries were formed of two or three platoons, each of which consisted of two sections. A section was a piece of light artillery with men and horses. Light artillery was still divided into two types: horse and mounted. The former was to stay with cavalry, and the latter was to work with infantry. Ibid., pp. 207, 405. Except in theory, the two titles were really meaningless as separate designations in the depleted postwar field artillery. Also, in the Army, the designation "garrison" for heavy artillery had largely fallen into disuse by the 1870's.

¹¹⁰Ibid., p. 514. The famous command, "Do not fire until you see the whites of their eyes," was not so much poetic as it was practical.

¹¹¹Ibid., p. 515.

¹¹²Ibid. Bores grooved with right-handed twist caused projectiles to spin from left to right causing a rightward drift.

¹¹³Ibid., p. 522.

¹¹⁴Ibid., p. 525.

¹¹⁵Ibid.

¹¹⁶Ibid., pp. 520-523, 525.

¹¹⁷As George McClellan correctly observed in 1874, the Europeans were giving emphasis to flat trajectories in field artillery design. "Modern Weapons and Modern Tactics," Army and Navy Journal, 1 August 1874, p. 807.

¹¹⁸"A Few Thoughts on the Artillery," Journal, 9 September 1871, p. 65.

NOTES

CHAPTER VI

¹U.S., War Department, Official Army Register for January, 1870 (Washington, D.C.: Adjutant General's Office, 1870), pp. 33-34; and U.S., War Department, Official Army Register for January, 1879 (Washington, D.C.: Adjutant General's Office, 1879), p. 101.

²See, U.S., Congress, House, Report of the Secretary of War, Ex. Doc. No. 1, 43d Cong., 2d sess., 1874, pt. 2, 1:257, 382-385.

³Army and Navy Journal, 8 November 1873, p. 206.

⁴Army and Navy Journal, 25 October 1873, p. 174.

⁵House, Report of the Secretary of War, Ex. Doc. No. 1, 43d Cong 1st sess., 1873, pt. 2, 3:457.

⁶House, Report of the Secretary of War, Ex. Doc. No. 1, 43d Cong., 2d sess., 1874, pt. 2, 1:382, 283, 285.

⁷U.S., Congress, House, "Letter from the Secretary of War," Ex. Doc. No. 69, 43d Cong., 1st sess., 1874, pp. 1-3. Charcoal was used for the production of high quality cast iron for cannons, but coal was used in the normal manufacture of the metal for civilian purposes.

⁸Ibid., p. 3.

⁹James D. Richardson, ed., A Compilation of the Messages and Papers of the President, 20 vols. (n.p.: Bureau of National Literature, 1897), 10:4271.

¹⁰House, Report of the Secretary of War, Ex. Doc. No. 1, 44th Cong., 1st sess., 1875, pt. 2, 3:10.

¹¹Ibid., 3:94.

¹²Ibid., 3:10.

¹³Ibid., 3:11.

¹⁴U.S., Congress, House, Report of the Secretary of War, Ex. Doc. No. 1, 44th Cong., 2d sess., 1876, pt. 2, 3:10, 55.

¹⁵House, Report of the Secretary of War, Ex. Doc. No. 1, 44th

Cong., 1st sess., 1875, pt. 2, 3:95.

¹⁶"The New Eighty-One Ton Gun," Army and Navy Journal, 16 May 1874, p. 631.

¹⁷House, Report of the Secretary of War, Ex. Doc. No. 1, 44th Cong., 1st sess., 1875, pt. 2, 3:380.

¹⁸Army and Navy Journal, 8 June 1876, p. 358.

¹⁹"The One Hundred Ton Gun," Army and Navy Journal, 2 September 1876, p. 59.

²⁰"Foreign Items," Army and Navy Journal, 20 January 1877, p. 383.

²¹House, Report of the Secretary of War, Ex. Doc. No. 1, 44th Cong., 2d sess., 1876, pt. 2, 3:10-11.

²²House, Report of the Secretary of War, Ex. Doc. No. 1, 44th Cong., 1st sess., 1875, pt. 2, 3:96.

²³House, Report of the Secretary of War, Ex. Doc. No. 1, 44th Cong., 2d sess., 1876, pt. 2, 3:86, 94.

²⁴U.S., Congress, House, Report of the Secretary of War, Ex. Doc. No. 1, 45th Cong., 2d sess., 1877, pt. 2, 3:XVIII.

²⁵Ibid.

²⁶Ibid., 3:XXV.

²⁷House, Report of the Secretary of War, Ex. Doc. No. 1, 41st Cong., 2d sess., 1869, pt. 2, p. 443.

²⁸House, Report of the Secretary of War, Ex. Doc. No. 1, 45th Cong., 2d sess., 1877, pt. 2, 3:XXV.

²⁹Ibid., 3:471.

³⁰Ibid., 3:471-472.

³¹Ibid., 3:505.

³²U.S., Congress, House, Report of the Secretary of War, Ex. Doc. No. 1, 46th Cong., 3d sess., 1880, pt. 2, 3:5.

³³House, Report of the Secretary of War, Ex. Doc. No. 1, 45th Cong., 2d sess., 1877, pt. 2, 3:4/5, 517.

³⁴"The Eyes of Artillery," Army and Navy Journal, 4 November 1876.

³⁵"Pointing Heavy Guns," Army and Navy Journal, 9 May 1874,

p. 618.

³⁶Army and Navy Journal, 7 October 1876, p. 142.

³⁷John Batchelor and Ian Hogg, Artillery (New York: Ballantine Books, 1972), p. 61.

³⁸Army and Navy Journal, 3 March 1877, p. 486.

³⁹Army and Navy Journal, 11 September 1875, p. 78. For battle-field illumination, by 1877, the British had already developed a parachute light, and they were in the process of developing artillery star clusters. Army and Navy Journal, 29 December 1877, p. 334.

⁴⁰Army and Navy Journal, 26 September 1874, p. 111.

⁴¹Thilo Von Trotha, Tactical Studies of the Battles Around Plevna, trans. Carl Reichmann, Arthur L. Wagner, ed., International Series, no. 3 (Kansas City, Missouri: Hudson-Kimberly Company, 1896), pp. 206-208. Wagner was an influential instructor at the U.S. Infantry and Cavalry School at Fort Leavenworth. In 1896, he made Von Trotha's book available in English for the first time.

⁴²Ibid., p. 222.

⁴³"The Modern Breechloader," Army and Navy Journal, 13 April 1878, p. 571.

⁴⁴Ibid. There were twenty 24-pounder siege guns in the Russian artillery at Plevna. Von Trotha, Tactical Studies, p. 224.

⁴⁵Ibid., p. 226.

⁴⁶"The Breechloader in Warfare," Army and Navy Journal, 13 April 1878, p. 575.

⁴⁷Comparato, Great Guns, p. 69.

⁴⁸Comparato, Great Guns, pp. 68-69. Shrapnel was named for Lieutenant Henry Shrapnel of the British Army who had invented spherical case about 1784. Ibid., p. 67.

⁴⁹Von Trotha, Tactical Studies, p. 223, 225.

⁵⁰Ibid., p. 225.

⁵¹See Comparato, Great Guns, p. 116.

⁵²Ibid. Comparato relates the Soviet boast that in 1877 a Russian inventor designed a 2.5-inch quick-firing gun; the first the world had seen. Ibid. Whether the story is true or not, European and American development of such weapons was still years away.

⁵³"Artillery Practice at Cronstadt," Army and Navy Journal,

7 April 1877, p. 562.

⁵⁴"Aligning Guns Under Cover," Army and Navy Journal, 25 May 1878, p. 836.

⁵⁵Army and Navy Journal, 6 January 1877, p. 350.

⁵⁶Ibid.

⁵⁷Army and Navy Journal, 13 October 1877, p. 150.

⁵⁸House, Report of the Secretary of War, Ex. Doc. No. 1, 45th Cong., 2d sess., 1877, pt. 2, 3:503.

⁵⁹Army and Navy Journal, 4 November 1876, p. 207.

⁶⁰"Foreign Intelligence," Army and Navy Journal, 28 August 1880, p. 74.

⁶¹Army and Navy Journal, 29 September 1877, p. 121.

⁶²Army and Navy Journal, 29 December 1877, p. 334.

⁶³"French Portable Field Telephone," Army and Navy Journal, 5 February 1881, p. 551.

⁶⁴U.S., Congress, House, Report of the Secretary of War, Ex. Doc. No. 1, 46th Cong., 2d sess., 1879, pt. 2, 1:179.

⁶⁵U.S., War Department, Annual Report of the Secretary of War for the Year 1881 (Washington, D.C.: Government Printing Office, 1881), 1:174.

⁶⁶U.S., War Department, Annual Report of the Secretary of War for the Year 1886 (Washington, D.C.: Government Printing Office, 1886), 1:199.

⁶⁷U.S., War Department, Annual Report of the Secretary of War for the Year 1890 (Washington, D.C.: Government Printing Office, 1890), 1:15; and U.S., War Department, Annual Report of the Secretary of War for the Year 1898 (Washington, D.C.: Government Printing Office, 1898), 1:29.

⁶⁸U.S., War Department, Annual Report of the Secretary of War for the 1887 (Washington, D.C.: Government Printing Office, 1887), vol. 4, pt. 1, p. 4.

⁶⁹See U.S., War Department, Annual Report of the Secretary of War for the Year 1892 (Washington, D.C.: Government Printing Office, 1892), 1:596.

⁷⁰U.S., War Department, General Orders Number 89, 21 October 1875.

71 U.S., War Department, General Orders Number 92, 10 November 1875.

72 U.S., War Department, Report of the Secretary of War (Washington, D.C.: Government Printing Office, 1878), 3:VIII-IX. The 8-inch weapons were made by the breech insertion of wrought-iron tubes into 10-inch cannons. To convert the design to a breech-loader, the Department used a steel insert tube that projected through the rear of the cast-iron barrel. For extra strength, a steel hoop was then heated and shrunk on the cast-iron of the rear portion of the barrel. The breech-loading mechanism, or fermeture as it was called, was fixed to the steel insert tube. Birnie, Gun Making, p. 27.

73 "The Problem of Naval Guns," Army and Navy Journal, 11 January 1879, p. 396.

74 "The Thunderer Gun Trials," Army and Navy Journal, 7 February 1880, p. 544.

75 House, Report of the Secretary of War, Ex. Doc. No. 1, 46th Cong., 2d sess., 1879, pt. 2, 3:8.

76 House, Report of the Secretary of War, Ex. Doc. No. 1, 46th Cong., 3d sess., 1880, pt. 2, 3:XIV.

77 War Department, Report of the Secretary of War, 1878, 3:IX.

78 House, Report of the Secretary of War, Ex. Doc. No. 1, 46th Cong., 3d sess., 1880, pt. 2, 3:XIV.

79 U.S., Congress, House, Report of the Secretary of War, Ex. Doc. No. 1, 46th Cong., 2d sess., 1879, pt. 2, 3:6-7.

80 House, Report of the Secretary of War, Ex. Doc. No. 1, 46th Cong., 3d sess., 1880, pt. 2, 3:XI.

81 Comparato, Great Guns, p. 77.

82 House, Report of the Secretary of War, Ex. Doc. No. 1, 46th Cong., 2d sess., 1879, pt. 2, 3:77.

83 "Power of Chambered Guns," Army and Navy Journal, 17 August 1878, p. 30.

84 House, Report of the Secretary of War, Ex. Doc. No. 1, 46th Cong., 2d sess., 1879, pt. 2, 3:8.

85 House, Report of the Secretary of War, Ex. Doc. No. 1, 46th Cong., 3d sess., 1880, pt. 2, 3:XIII.

86 House, Report of the Secretary of War, Ex. Doc. No. 1, 46th Cong., 2d sess., 1879, pt. 2, 3:77.

87 See Birnie, Gun Making, pp. 31-32.

⁸⁸House, Report of the Secretary of War, Ex. Doc. No. 1, 46th Cong., 2d sess., 1879, pt. 2, 3:9.

⁸⁹See Birnie, Gun Making, pp. 32. In 1877, the Department purchased a breech-loading 1.65-inch mountain rifle (not field artillery) from B. B. Hotchkiss for a test on the frontier. The small caliber weapon was a success and forces in the field called for more. Benet proposed to release the remaining five that the Department held. War Department, Report of the Secretary of War, 1878, p. XIII.

⁹⁰House, Report of the Secretary of War, Ex. Doc. No. 1, 46th Cong., 3d sess., 1880, pt. 2, 3:XIII.

⁹¹Ibid.

⁹²Ibid.

⁹³House, Report of the Secretary of War, Ex. Doc. No. 1, 45th Cong., 2d sess., 1877, pt. 2, 3:619.

⁹⁴Comparato, Great Guns, p. 33.

⁹⁵House, Report of the Secretary of War, Ex. Doc. No. 1, 45th Cong., 2d sess., 1877, pt. 2, 3:620-621.

⁹⁶Ibid., 3:620.

⁹⁷House, Report of the Secretary of War, Ex. Doc. No. 1, 46th Cong., 2d sess., 1879, pt. 2, 3:161.

⁹⁸House, Report of the Secretary of War, Ex. Doc. No. 1, 46th Cong., 3d sess., 1880, pt. 2, 3:5.

⁹⁹Robert M. Utley, Frontier Regulars: The United States Army and the Indian, 1866-1890 (New York: Macmillan Publishing Company, 1973), p. 74.

¹⁰⁰McKenney, "Field Artillery," p. 122.

¹⁰¹U.S., War Department, Ordnance Office, Ordnance Notes, Nos. 101-125, Note No. 119, 3 November 1879, pp. 190-191.

¹⁰²Ibid., p. 197.

¹⁰³Ibid., pp. 200-201.

¹⁰⁴Ibid, p. 197.

¹⁰⁵From a survey of the Report of the Secretary of War for the years 1870-1880.

NOTES

CHAPTER VII

¹U.S., Congress, Senate, Evidence Taken Before the Committee on Appropriations of the Senate, Mis. Doc. No. 44, 47th Cong., 1st sess., 1882, pp. 1, 2, 7, 9, 26, 60. The method of conversion was the breech insertion of a wrought-iron bore tube.

²Ibid., pp. 21, 28, 58, 60-61.

³Ibid., p. 29.

⁴Ibid., pp. 51-52, 61.

⁵Ibid., p. 52.

⁶U.S., War Department, General Orders Number 48, 16 May 1881. Benton died in August 1881 and was replaced by Major Francis H. Parker, Ordnance Department. U.S., Congress, Senate, Report of the Board on Heavy Ordnance and Projectiles, Ex. Doc. No. 178, 44th Cong., 1st sess., 1882, p. 4.

⁷Ibid., pp. 1, 8.

⁸Senate, Evidence Taken Before the Committee on Appropriations, Mis. Doc. No. 44, 47th Cong., 1st sess., 1882, p. 12.

⁹For Example see "Guns for the Army and Navy," Army and Navy Journal, 12 February 1881, p. 571; and "The Mixed Ordnance Board," Army and Navy Journal, 2 April 1881, p. 730.

¹⁰Daily Advertiser quoted in the Army and Navy Journal, 17 December 1881, p. 435.

¹¹Army and Navy Journal, 12 November 1881, p. 323.

¹²Birnie, Gun Making, p. 35.

¹³U.S., War Department, Annual Report of the Secretary of War for the Year 1882 (Washington, D.C.: Government Printing Office, 1882), 3:6.

¹⁴Ibid., 3:8.

¹⁵U.S., War Department, Annual Report of the Secretary of War for

the Year 1883 (Washington, D.C.: Government Printing Office, 1884), 3:5-6.

¹⁶War Department, Annual Report, 1882, 3:8.

¹⁷U.S., Congress, House, Report of the Gun Foundry Board, Ex. Doc. No. 97, 48th Cong., 1st sess., 1884, pp. 1-2.

¹⁸Ibid. Board members were Rear Admiral E. Simpson; Captain E. O. Matthews, Navy; Colonel T. G. Baylor, Ordnance; Lieutenant Colonel Henry L. Abbot; Engineers; Major Samuel S. Elder, Artillery; and Lieutenant W. H. Jaques, Navy. Krupp's refusal was good business sense. He did not want American officers touring his facilities if they were there to inspect his manufacturing process rather than to buy weapons. Ibid., pp. 63-67.

¹⁹Ibid., p. 39.

²⁰Blaine, Twenty Year of Congress, 1:634. The following is the annual tonnage of steel railroad bars produced in America:

1866	-	1874	129,414
1867	2,277	1875	259,699
1868	6,451	1876	368,269
1869	8,616	1877	385,865
1870	30,357	1878	499,817
1871	34,152	1879	618,851
1872	83,991	1880	684,353
1873	155,192	1881	1,210,285

²¹War Department, Annual Report, 1883, 3:6-10.

²²House, Report of the Gun Foundry Board, pp. 47-49.

²³Prior to, and during the Civil War, guns were produced by:
 The Cold Spring Foundry, West Point, N.Y.
 The South Boston Iron Works, Boston, Mass.
 The Fort Pitt Foundry, Pittsburg, Pa.
 The Reading Iron Works, Reading, Pa.
 The Builders' Iron Foundry, Providence, R.I.
 The Phoenix Iron Company, Phoenixville, Pa.
 The Ames Manufacturing Company, Chicopee, Mass.

Since the Civil War, the Fort Pitt Company had gone out of business and the few orders given the Department had been executed by the South Boston and West Point Foundries. Ibid., p. 39.

²⁴Ibid., pp. 8-10, 35-36, 47.

²⁵War Department, Annual Report, 1887, 3:10.

²⁶U.S., War Department, General Orders Number 39, 28 April 1881.

²⁷"The Light Artillery Board," Army and Navy Journal, 8 October 1881, p. 115.

²⁸War Department, Annual Report, 1882, 3:9-10.

²⁹War Department, Annual Report, 1883, 3:289.

³⁰U.S., War Department, Artillery School, "Comparisons of the Armaments of European Nations, Describing Their Systems of Artillery" essay by Alexander D. Schenck (Fort Monroe, Virginia: Artillery School, 1886), p. 3. The Broadwell ring was the invention of L. W. Broadwell, an American, who went into the ordnance business in Germany. Comparato, Great Guns, pp. 318-319.

³¹Ibid., pp. 30-31.

³²Artillery School, "Comparison of the Armaments," p. 3.

³³Comparato, Great Guns, pp. 31-32.

³⁴Ibid., p. 198.

³⁵War Department, Annual Report, 1884, 3:19.

³⁶The velocity of the wrought-iron gun is taken from Harold L. Peterson, Round Shot, and Rammers (Harrisburg, Pa.: Stackpole Books, 1969), p. 96.

³⁷War Department, Annual Report, 1883, 3:313-315.

³⁸War Department, Annual Report, 1884, 3:541.

³⁹U.S., War Department, Annual Report of the Secretary of War for the Year 1885 (Washington, D.C.: Government Printing Office, 1885), 3:app. 57.

⁴⁰War Department, Annual Report, 1886, 3:23; and War Department, Annual Report, 1887, 3:92.

⁴¹"The New Field Guns," Army and Navy Journal, 26 December 1891, p. 313.

⁴²Army and Navy Journal, 7 June 1884, p. 930; and "Brown Powder," Army and Navy Journal, 6 September 1884, p. 110. In 1875, German mills began to produce brown powder. The British moved to establish similar production facilities six years later. Comparato, Great Guns, p. 76.

⁴³War Department, Annual Report, 1884, 3:17; and War Department, Annual Report, 1885, 3:x.

⁴⁴In Sweden, in 1867, Alfred Nobel began the production of dynamite. It was a mixture of white clay and nitroglycerine. Clay was used to add stability to the highly volatile nitroglycerine. Comparato, Great Guns, pp. 83-84. Nitroglycerine was first developed by A. Sobrero in 1846. It was made by treating glycerol with nitric and sulphuric acids. Encyclopaedia Britannica, 1955, ed., s.v. "Nitroglycerine," by George B. Kistiakowsky.

⁴⁵War Department, Annual Report, 1884, 3:18, 215. Guncotton was a high explosive made by treating cotton fiber with a mixture of nitric and sulphuric acids. Encyclopaedia Britannica, 1956 ed., s.v.

⁴⁶War Department, Annual Report, 1885, 3:113.

⁴⁷"The Dynamite Gun," Army and Navy Journal, 5 April 1884, p. 733

⁴⁸"American Guns," Army and Navy Journal, 21 June 1884, p. 965.

⁴⁹Birnie, Gun Making, pp. 35-36.

⁵⁰U.S., War Department, General Orders Number 26, 13 March 1885, p. 1.

⁵¹U.S., Congress, House, Report of the Board on Fortifications or Other Defenses, Ex. Doc. No. 49, 49th Cong., 1st sess., 1886, p. 1.

⁵²Ibid., p. 6.

⁵³Ibid., p. 28.

⁵⁴War Department, General Order Number 26, 13 March 1885, pp. 1-2

⁵⁵War Department, Annual Report, 1886, 3:8-9.

⁵⁶War Department, Annual Report, 1888, 3:5.

⁵⁷War Department, Annual Report, 1885, 3:xxii.

⁵⁸War Department, Annual Report, 1886, 3:22, 203.

⁵⁹U.S., War Department, Artillery School, "Material for Field Artillery for the United States Army," essay by Alexander D. Schenck (Fort Monroe, Virginia: Artillery School, 1886), p. 3.

⁶⁰Artillery School, "Comparison of the Armaments," pp. 16-17.

⁶¹Artillery School, "Material for Field Artillery," pp. 3-4.

⁶²War Department, Annual Report, 1883, 3:289.

⁶³War Department, Annual Report, 1886, p. 203.

⁶⁴U.S., War Department, Adjutant General's Office, Artillery Circular I, Series of 1893: Modern Guns and Mortars (Washington, D.C.: Government Printing Office, 1895), p. 156.

⁶⁵War Department, Annual Report, 1886, 3:203.

⁶⁶Artillery School, "Material for Field Artillery," pp. 2-5. The British were an exception to the six horse rule; they used eight animals to draw their 16-pounder, a position gun. American siege

horses, with a reduced need for mobility, were rated at about 1,000 pounds per animal. Ibid., pp. 3, 5.

⁶⁷Alexander B. Dyer, Handbook for Light Artillery, 4th ed. (New York: John Wiley and Sons, 1896), pp. 89, 131, 133.

⁶⁸War Department, Annual Report, 1887, 3:13, 169.

⁶⁹War Department, Annual Report, 1888, 3:8. Weapons could be tested from stationary mounts.

⁷⁰War Department, Annual Report, 1887, 3:181.

⁷¹War Department, Annual Report, 1886, 3:7.

⁷²War Department, Annual Report, 1887, 3:18-21.

⁷³In the appropriations act of 22 September 1888, Congress authorized and provided funds for the gun factory. U.S., War Department, Annual Report of the Secretary of War for the Year 1889 (Washington, D.C.: Government Printing Office, 1889), 3:8-9.

⁷⁴War Department, Annual Report, 1884, 3:18-19, 509.

⁷⁵War Department, Annual Report, 1885, 3:xxiv.

⁷⁶War Department, Annual Report, 1886, 3:453.

⁷⁷War Department, Annual Report, 1887, 3:13, 21.

⁷⁸Quoted in Thomas A. Bailey, A Diplomatic History of the American People, 9th ed. (Englewood Cliffs, New Jersey: Prentice-Hall, 1974), p. 402.

⁷⁹U.S., Congress, House, "Coast Defenses," Mis. Doc. No. 109, 49th Cong., 2d sess., 1887.

⁸⁰War Department, Annual Report, 1887, 3:11.

⁸¹U.S., Congress, House, Report of the Board of Ordnance and Fortifications, Ex. Doc. No. 12, 52d Cong., 2d sess., 1892, p. 7.

⁸²War Department, Annual Report, 1889, 3:10.

⁸³House, Report of the Board of Ordnance and Fortification, Ex. Doc. No. 12, 52d Cong., 2d sess., 1892, p. 7.

⁸⁴Ibid., pp. 7-9. For example, between 1888 and 1896, the board was concerned with the examination of a new site for an ordnance proving ground, the prescribing of conditions of tests for weapons, the selection of ". . . guns, small arms, cartridges, projectiles, fuses, explosives, torpedoes, armor plates, . . . and other war materials and articles as may in the judgement of the Board, be necessary in the proper discharge of the duty leveled upon it . . ." Ibid., p. 29.

⁸⁵Ibid. The board reviewed 350 inventions between 1888 and 1891 to include: guns, carriages, powders, shells, small arms, applications of electricity, optical devices, and many others. From 1894 to 1904, Congress annually appropriated about \$100,000 solely to finance the administration and experimental work of the board. See reports from U.S., War Department, Fourth Report of the Board of Ordnance and Fortification to the Secretary of War (Washington, D.C.: Government Printing Office, 1894), to U.S., War Department, Fourteenth Report of the Board of Ordnance and Fortification (Washington, D.C.: Government Printing Office, 1904).

⁸⁶Weigley, History, p. 266.

⁸⁷U.S., Congress, House, Report of the Secretary of War, Ex. Doc. No. 1, 50th Cong., 2d sess., 1888, pt. 2, 1:104.

⁸⁸Ibid., 1:104-105.

⁸⁹"Proceedings of the 1888 Board," Letters Received by the Office of the Adjutant General, Main Series, 1881-1889, Microcopy No. M-689, Rolls 587-606, Old Military Records Division, Record Group 94, Records of the Adjutant General's Office 1780's-1917, National Archives, Washington, D.C., Roll No. 601, Special Order Number 14, 18 January 1888

⁹⁰Ibid., Roll 587, "Memorandum," 8 February 1888; and Roll 600, Memorandum of Decisions made on Tactics since January 1, 1888."

⁹¹Ibid., Roll 601, Letter to the Adjutant General, 31 October 1890.

⁹²Ibid., Roll 601, Letter to the Adjutant General, 31 March 1891, p. 3.

⁹³Ibid.

⁹⁴See U.S., War Department, Drill Regulations for Light Artillery, United States Army (Washington, D.C.: Government Printing Office, 1896), p. 387.

NOTES

CHAPTER VIII

¹U.S., Congress, House, Committee on Appropriations, The Fortification Appropriation Bill, Hearings, before a Subcommittee of the Committee on Appropriations, 54th Cong., 1st sess., 1896, p. 20.

²See, War Department, Annual Report, 1890, 3:32-36.

³War Department, Annual Report, 1889, 3:19.

⁴Dyer, Handbook, pp. 108-109.

⁵War Department, Annual Report, 1890, 3:22-23.

⁶"Memoranda, 3.6-inch Field Mortar," Board of Ordnance and Fortification General Correspondence, 1888-1919, No. 104, Old Military Records Division, Recored Group 165, National Archives, Washington, D.C.

⁷See Henry J. Reilly, "Siege Artillery," Journal of the United States Artillery 3(1894):35.

⁸See L. G. Berry, "The Artillery of Siege Warfare," Journal of the United States Artillery 2(1893):14.

⁹War Department, Annual Report, 1890, 3:5-6.

¹⁰Ibid., 3:27.

¹¹U.S., War Department, Annual Report of the Secretary of War for the Year 1891 (Washington, D.C.: Government Printing Office, 1892), 3:529.

¹²War Department, Artillery Circular I, Series of 1893, pp. 155-156.

¹³War Department, Annual Report, 1890, 3:37.

¹⁴U.S., War Department, Official Army Register for January, 1890 (Washington, D.C.: Adjutant General's Office, 1890), p. 46.

¹⁵Comparato, Great Guns, p. 84. Nitrocellulose was cotton or wood fibers soaked in a nitro-sulphuric acid mixture (guncotton), Vielle added special stabilizers to reduce the unpredictable sensitivity of the compound. Encyclopaedia Britannica, 1955 ed., s.v. "Nitrocellulose," by George B. Kistiakowsky.

- ¹⁶War Department, Annual Report, 1890, 3:5-6.
- ¹⁷War Department, Annual Report, 1891, 3:17.
- ¹⁸War Department, Annual Report, 1892, 3:22.
- ¹⁹See U.S., War Department, Annual Reports of the War Department for the Fiscal Year Ended June 30, 1897, Report of the Chief of Ordnance (Washington, D.C.: Government Printing Office, 1897), p. 32.
- ²⁰"Ordnance Notes," Army and Navy Journal, 7 June 1890, p. 786.
- ²¹Laurence V. Benet, "A Study of the Effects of Smokeless Powder in a 57mm Gun," Journal of the United States Artillery 1 (January 1892): 207.
- ²²War Department, Annual Report, 1891, 3:217.
- ²³House, Report of the Board of Ordnance and Fortification, Ex. Doc. No. 12, 52d Cong., 2d sess., January 1892, p. 25.
- ²⁴U.S., War Department, Tenth Report of the Board of Ordnance and Fortification (Washington, D.C.: Government Printing Office, 1900). p. 8.
- ²⁵War Department, Annual Report, 1892, 1:11.
- ²⁶See U.S., War Department, Annual Report of the Secretary of War for the Year 1894 (Washington, D.C.: Government Printing Office, 1894), 1:160-167.
- ²⁷War Department, Annual Report, 1892, 3:21.
- ²⁸War Department, Annual Report, 1895, 3:50.
- ²⁹War Department, Annual Report, 1893, 3:595, 612.
- ³⁰U.S., War Department, Annual Report of the Secretary of War for the Year 1893 (Washington, D.C.: Government Printing Office, 1893), 3:660-661.
- ³¹Ibid., 3:661-662.
- ³²"The Hotchkiss Cannon," Army and Navy Journal, 24 September 1887, p. 167.
- ³³See "Rapid Fire Guns--1890," table, Board of Ordnance and Fortification General Correspondence, 1888-1889, No. 966, Old Military Records Division, Record Group 165, National Archives, Washington, D.C.; and War Department, Annual Report, 1893, 3:661. In 1885, two firms, Hotchkiss and Nordenfelt, had a near monopoly on rapid-fire gun construction. By 1893, there were at least eighteen companies making the weapons.

³⁴Letter, Chief of Ordnance to Secretary of War, Board of Ordnance and Fortification General Correspondence, 1888-1889, No. 962, Old Military Records Division, Record Group 165, National Archives, Washington, D.C.

³⁵House, Report of the Board of Ordnance and Fortification, January, 1892.

³⁶House, Report of the Board of Ordnance and Fortification, Ex. Doc. No. 11, 52d Cong., 2d sess., December 1892, p. 21.

³⁷Letter, Chief of Ordnance to Secretary of War, Board of Ordnance and Fortification General Correspondence, 1888-1919, No. 962.

³⁸War Department, Annual Report, 1893, 3:670-671.

³⁹See War Department, Annual Reports, 1897, Chief of Ordnance, p. 43. The Department experimented with cases of both brass and aluminum. In tests, the latter metal was unsatisfactory. U.S., War Department, Annual Report of the Secretary of War for the Year 1896 (Washington, D.C.: Government Printing Office, 1897), 3:45.

⁴⁰House, Report of the Board of Ordnance and Fortification, January 1892, p. 25. The Department tested breeches of four types: Gerdon, Dashiell, Fletcher, and Seabury. It eventually settled on the Gerdon, a modified interrupted-screw design. War Department, Annual Reports, 1897, 3:38; and U.S., War Department, Annual Reports of the War Department for the Fiscal Year Ended June 30, 1902 (Washington, D.C.: Government Printing Office, 1902), 3:10.

⁴¹U.S., War Department, Annual Report of the Secretary of War for the Year 1895 (Washington, D.C.: Government Printing Office, 1896), 3:53.

⁴²"The Rapid-Fire Field and Landing Gun," Army and Navy Journal, 8 December 1894, p. 247.

⁴³War Department, Annual Report, 1895, 3:53.

⁴⁴See Comparato, Great Guns, pp. 35-37.

⁴⁵War Department, Annual Report, 1895, 3:53.

⁴⁶War Department, Annual Report, 1897, 3:32, 38-39. The shrapnel round for the new gun was designed with a greater sectional density than the 3.2-inch projectile, which would contribute to a higher velocity at all ranges. The weights of the two rounds were: 3-inch, 15 pounds; 3.2-inch, 16.5 pounds.

⁴⁷War Department, Annual Report, 1893, 3:672.

⁴⁸Ibid., 3:672-673.

⁴⁹Arthur L. Wagner, Organization and Tactics (New York:

B. Westermann and Co., 1895), p. 356.

⁵⁰Dyer, Handbook, p. 390.

⁵¹War Department, Drill Regulations, 1896, pp. 394-395, 404.

⁵²Moriz Edler von Reichold, "Indirect Fire," trans. J. A. Shipton, Journal of the United States Artillery 8(1897);171.

⁵³Letters on Artillery quoted in Wagner, Organization, p. 356.

⁵⁴Edler, "Indirect Fire," Journal of the Artillery, pp. 170, 173.

⁵⁵U.S., War Department, Military Information Division, The Military System of Sweden and Other Papers Selected for Publication (Washington, D.C.: Government Printing Office, 1896), p. 154. Of course, the Germans were concerned about the potential need to reduce the increasingly formidable line of French border forts that had been constructed since the 1870's. For a description see Keith Mallory and Arvid Otter, The Architecture of War (New York: Pantheon Books, Random House, 1973).

⁵⁶Wagner, Organization, p. 57, 66.

⁵⁷War Department, Annual Report, 1894, p. 46.

⁵⁸War Department, Drill Regulations, 1896, p. 412. High explosives were not available in American service ammunition.

⁵⁹"Proceedings of the Board of Ordnance and Fortifications," vol. 3, Records of the War Department General and Special Staffs, Old Military Records Division, Record Group 165, National Archives, Washington, D.C., p. 73.

⁶⁰War Department, Drill Regulations for Light Artillery, 1896, pp. 381, 424-431.

⁶¹U.S., War Department, Troops in Campaign, Regulations for the Army of the United States (Washington, D.C.: Government Printing Office, 1892), p. 8.

⁶²Wagner, Organization, p. 335.

⁶³War Department, Drill Regulations for Light Artillery, 1896, pp. 386-387.

⁶⁴Ibid., pp. 385, 414.

⁶⁵Wagner, Organization, p. 339.

⁶⁶U.S., War Department, Fifth Report of the Board of Ordnance and Fortification (Washington, D.C.: Government Printing Office, 1895), p. 16.

⁶⁷War Department, Annual Reports, 1897, 3:44.

⁶⁸War Department, Fifth Report of the Board of Ordnance and Fortification, p. 17.

⁶⁹U.S., War Department, Sixth Report of the Board of Ordnance and Fortification (Washington, D.C.: Government Printing Office, 1896), pp. 41, 47-59. The board consisted of Lieutenants Henry L. Harris, William C. Rafferty, and Isaac N. Lewis, all of the Artillery.

⁷⁰War Department, Eighth Report of the Board of Ordnance and Fortification, p. 10.

⁷¹U.S., Congress, House, Report of the Secretary of War, Ex. Doc. 1, 51st Cong., 1st sess., 1889, pt. 2, 1:65.

⁷²U.S., Congress, House, Report of the Secretary of War, Ex. Doc. No. 1, 52d Cong., 2d sess., 1892, pt. 2, 1:48; and Weigley, History, p. 567.

⁷³For instance, Schofield repeated the request in 1892, as did his successor Lieutenant General Miles three years later. See House, Report of the Secretary of War, Ex. Doc. No. 1, 52d Cong., 2d sess., 1892, pt. 2, 1:47; and Letter, Lieutenant General Miles to the Secretary of War, 28 December 1895, Records of the Adjutant General's Office, 1780's-1917, No. 54647, Old Military Records Division, Record Group 94, National Archives, Washington, D.C.

⁷⁴"Prospects for Army Legislation," Army and Navy Journal, 7 March 1896, p. 474.

⁷⁵"Increasing the Artillery," Army and Navy Journal, 2 October 1897, p. 72.

⁷⁶Ernest Dupuy, The Compact History of the United States Army (New York: Hawthorn Books, 1951), pp. 168, 171.

⁷⁷"Artillery Bill Passes the Senate," Army and Navy Journal, 26 February 1898, p. 474; and "The New Artillery Regiments," Army and Navy Journal, 12 March 1898, p. 513.

⁷⁸Weigley, History, p. 295.

⁷⁹The Santiago Campaign (Richmond, Virginia: Williams Printing Company, 1927), p. 181. The book is a collection of personal reminiscences of the Cuban expedition.

⁸⁰C. D. Parkhurst, "The Artillery at Santiago," Journal of the United States Artillery 11(1898):139.

⁸¹U.S., War Department, Annual Reports of the Secretary of War for the Fiscal Year Ended June 30, 1898 (Washington, D.C.: Government Printing Office, 1899), 3:21-23.

⁸²"Memorandum for Major Johnson," 16 November 1899, Records of the Adjutant General's Office, 1780's-1917, Doc. No. 220887, Old Military Records Division, Record Group 94, National Archives, Washington, D.C.

⁸³The Santiago Campaign, p. 184.

⁸⁴War Department, Annual Reports, 1898, 3:23.

⁸⁵Vincent J. Esposito, ed., The West Point Atlas of American Wars, vol. 1 1689-1900 (New York: Frederick A. Praeger, 1959), map 156.

⁸⁶The Santiago Campaign, pp. 184, 188.

⁸⁷Ibid., pp. 188, 190-193; and Arthur L. Wagner, Report of the Santiago Campaign (Kansas City, Missouri: Franklin Hudson Publishing Co., 1908), pp. 73, 77, 87-88, 118.

⁸⁸Parkhurst, "The Artillery at Santiago," Journal of the Artillery pp. 169-170.

⁸⁹Wagner, Santiago Campaign, p. 116.

⁹⁰Ibid., p. 107.

⁹¹Ibid., pp. 106, 118.

⁹²For instance see "Results of the Santiago Battles," Army and Navy Journal, 23 July 1898, p. 952; "The Artillery at San Juan," Army and Navy Journal, 19 November 1898, p. 274; and "Honor to the Artillery," Army and Navy Journal, 28 January 1899, p. 516.

⁹³Esposito, Atlas, vol. 1:1889-1900, map 158.

⁹⁴Wagner, Santiago Campaign, p. 119.

⁹⁵See The Santiago Campaign, p. 191; and Wagner, Santiago Campaign, p. 87.

⁹⁶See "The Artillery at Santiago," Army and Navy Journal, 27 May 1899, p. 923.

⁹⁷U.S., Congress, House, Annual Reports of the War Department for the Fiscal Year Ended June 30, 1900, Report of the Chief of Ordnance, Doc. No. 2, 56th Cong., 2d sess., 1900, pp. 336-337.

⁹⁸U.S., Congress, Senate, Report of the Commission Appointed by the President to Investigate the Conduct of the War Department in the War with Spain, vol. 1, Doc. No. 221, 56th Cong., 1st sess., 1900, p. 199. The Dodge Commission was named for its president, Greenville M. Dodge.

⁹⁹"British and Boer Artillery," Army and Navy Journal, 31 March 1900, p. 717.

¹⁰⁰U.S., War Department, Office of the Chief of Staff, Second Division, General Staff, Selected Translations Pertaining to the Boer War. "Notes on the Artillery in the South African War," by P. Van Rerchem (Washington, D.C.: Government Printing Office, 1905), p. 23.

¹⁰¹Army and Navy Journal, 22 September 1900, p. 75.

¹⁰²"An Experts Opinion," Army and Navy Journal, 3 March 1900, p. 620, citing a letter from Major Albrecht, the Boer artillery commander, to Deutsche Worte.

¹⁰³"Lessons of the Boer War," Army and Navy Journal, 8 September 1900, p. 42, citing a Sun correspondent with British troops in South Africa.

¹⁰⁴Oliver L. Spaulding, Artillery in Defense (Ft. Leavenworth, Kansas: Staff College Press, 1904), p. 1.

NOTES

CHAPTER IX

¹U.S., War Department, Annual Reports of the War Department for the Fiscal Year Ended June 30, 1899, vol. 1, pt. 3 (Washington, D.C.: Government Printing Office, 1899), p. 401.

²"A Coast Artillery Corps," Army and Navy Journal, 27 October 1900, p. 215.

³"What do the Artillery Want?" Army and Navy Journal, 29 December 1900, p. 418. The movement toward a corps organization was underway in 1898. See U.S., Congress, House, Reorganization of the Army, Rpt. 1709, 55th Cong., 3d sess., 1898, pt. 1, p. 4.

⁴War Department, Annual Reports, 1899, vol. 1, pt. 3, p. 52.

⁵"Secretary Root's Plan of Reorganization," Army and Navy Journal, 24 February 1900, p. 595.

⁶U.S., War Department, Annual Reports of the War Department for the Fiscal Year Ended June 30, 1900, vol. 1, pt. 1 (Washington, D.C.: Government Printing Office, 1900), p. 50; and Weigley, History, pp. 317, 568.

⁷"Secretary Root's Plan of Reorganization," Journal, 24 February 1900, p. 595. The field branch would also contain horse, mountain, and machine gun batteries.

⁸War Department, Annual Reports, 1899, vol. 1, pt. 3, p. 52.

⁹U.S., Congress, Senate, "Selection of Captain Crozier for Chief of Ordnance," Doc. No. 387, 57th Cong., 1st sess., 1902, p. 1.

¹⁰Ibid.

¹¹U.S., War Department, Ninth Report of the Board of Ordnance and Fortification (Washington, D.C.: Government Printing Office, 1899), p. 11.

¹²U.S., War Department, Official Army Register for 1900 (Washington, D.C.: Adjutant General's Office, 1899), p. 45. The disappearing carriage mechanically raised a gun above a wall to fire and then lowered it for reloading.

¹³"Proceedings of the Board of Ordnance and Fortifications,"

vol. 11, Records of the War Department General and Special Staffs, Old Military Records Division, Record Group 165, National Archives, Washington, D.C., p. 77. Lewis is best known for his invention of the Lewis machine gun used by the Allies in World War I.

¹⁴"The French Field Gun," Army and Navy Journal, 24 November 1900, p. 307.

¹⁵U.S., Congress, Senate, "Disappearing Carriages for the Seacoast Fortifications," Doc. No. 332, 56th Cong., 1st sess., 1900, pp. 1-5. The United States had free use of the Buffington-Crozier Carriage. Senate, "Selection of Captain Crozier for Chief of Ordnance," Doc. No. 387, 57th Cong., 1st sess., 1902, p. 21.

¹⁶See U.S., War Department, Tenth Report of the Board of Ordnance and Fortification (Washington, D.C.: Government Printing Office, 1900), p. 3.

¹⁷House, Annual Reports, 1900, Report of the Chief of Ordnance, Doc. No. 2, 56th Cong., 2d sess., pp. 331-332, 337.

¹⁸"The French Field Gun," Journal, 24 November 1900, p. 307.

¹⁹U.S., War Department, Annual Reports of the War Department for the Fiscal Year Ended June 30, 1901 (Washington, D.C.: Government Printing Office, 1902), 3:612-613. Picric acid, as a high explosive, was called "Lyddite" in England, "melinite" in France and Germany and "shinosite" in Japan. It was a nitro-compound, originally used as a yellow fabric dye. Rendrook explosive 400 contained a lead salt and a nitrated hydro-carbon. Encyclopaedia Britannica, 1955 ed., s.v. "Picric Acid or Lyddite," by William R. Hodgkinson; and "Extract from Report of the Ordnance Board," Board of Ordnance and Fortification General Correspondence, 1888-1919, No. 5000, Old Military Records Division, Record Group 165. National Archives, Washington, D.C. The report contains a summary of the Department efforts with high-explosives in 1901.

²⁰"Proceedings of the Board of Ordnance and Fortification," vol. 12, Records of the War Department General and Special Staffs, Old Military Records Division, Record Group 165, National Archives, Washington, D.C., pp. 59-60.

²¹Ibid.

²²House, Annual Reports, 1900, Report of the Chief of Ordnance, Doc. No. 2, 56th Cong., 2d sess., p. 402.

²³Ibid., p. 403.

²⁴War Department, Annual Reports, 1901, 3:50.

²⁵House, Annual Reports, 1900, Report of the Chief of Ordnance, Doc. No. 2, 56th Cong., 2d sess., pp. 401, 403, 405.

²⁶"Proceedings of the Board of Ordnance and Fortifications," vol. 12, National Archives, pp. 59-60.

²⁷House, Annual Reports, 1900, Report of the Chief of Ordnance, Doc. No. 2, 56th Cong., 2d sess., pp. 406-408.

²⁸Letter, Chief of Ordnance to the Secretary of War, 27 March 1903, Records of the Office of the Chief of Ordnance, 1888-1915, No. 37835, Enc. 7, Old Military Records Division, Group 156, National Archives, Washington, D.C. The request was forwarded through the Chief of Artillery to the Field Artillery Board. The board then recommended that field artillery batteries be given twelve caissons.

²⁹Comparato, Great Guns, pp. 37-39. It was subsequently calculated that the energy released in firing the "75" was equal to that of an automobile going 100 miles per hour. Without jarring the wheels, the "75" absorbed the energy within about a yard of barrel recoil.

³⁰"A New French Cannon," Army and Navy Journal, 17 March 1900, p. 681.

³¹See Comparato, Great Guns, p. 39.

³²Letter, Captain I. N. Lewis to the Adjutant General, 20 October 1900, Records of the Adjutant General's Office, 1780's-1917, No. 332323, Old Military Records Division, Record Group 94, National Archives, Washington, D.C.

³³Ibid., p. 8.

³⁴Ibid., p. 9.

³⁵Letter, Captain I. N. Lewis to the Secretary of War, 16 October 1900, Board of Ordnance and Fortification General Correspondence, 1888-1919, No. 4908, Old Military Records Division, Record Group 165, National Archives, Washington, D.C.

³⁶Ibid. Lewis offered to place his information ". . . unreservedly at the disposal of the government."

³⁷"Proceedings of the Board of Ordnance and Fortification," vol. 12, National Archives, pp. 94-95.

³⁸See "The French Field Gun," Army and Navy Journal, 17 November 1900, p. 273; and "The French Field Gun," Army and Navy Journal, 24 November 1900, p. 301.

³⁹Letter, Captain I. N. Lewis to Lieutenant General Nelson A. Miles, 11 November 1900, with newspaper clippings, Records of the Adjutant General's Office, 1780's-1917, No. 332323, Old Military Records Division, Record Group 94, National Archives, Washington, D.C.

⁴⁰Letter, Henry Vignaud to John Hay, 17 November 1900, Records of the Adjutant General's Office, 1780's-1917, No. 332323, Old Military

Records Division, Record Group 94, National Archives, Washington, D.C.

⁴¹Letter, John Hay to the Secretary of War, 28 November 1900, Records of the Adjutant General's Office, 1780's-1917, No. 332323, Old Military Records Division, Record Group 94, National Archives, Washington, D.C.

⁴²Letter, Lewis to Miles, 11 November 1900, Adjutant General's Office, No. 332323.

⁴³New York Herald, Paris Edition, quoted in "The French Field Gun," Army and Navy Journal, 24 November 1900, p. 307.

⁴⁴Letter, Lewis to Miles, 11 November 1900, 1st indorsement, 12 November 1900, Adjutant General's Office, No. 332323.

⁴⁵Letter, A. R. Buffington to the Adjutant General, 26 November 1900, Records of the Adjutant General's Office, 1780's-1917, No. 332323, Old Military Records Division, Record Group 94, National Archives, Washington, D.C.

⁴⁶Letter, A. R. Buffington to the Secretary of War, 26 November 1900, Records of the Adjutant General's Office, 1780's-1917, No. 332323, Old Military Records Division, Record Group 94, National Archives, Washington, D.C.

⁴⁷Letter, C. E. Dutton to General Buffington, 28 November 1900, Records of the Adjutant General's Office, 1780's-1917, No. 332323, Old Military Records Division, Record Group 94, National Archives, Washington, D.C.

⁴⁸U.S., War Department, Eleventh Report of the Board of Ordnance and Fortification (Washington, D.C.: Government Printing Office, 1901), p. 10.

⁴⁹War Department, Annual Reports, 1901, vol. 1, pt. 1, p. 14.

⁵⁰"Proceedings of the Board of Ordnance and Fortification," vol. 13, Records of the War Department General and Special Staffs, Old Military Records Division, Record Group 165, National Archives, Washington, D.C., p. 75.

⁵¹Letter, William Crozier to the Secretary of War, 24 October 1901, Records of the Adjutant General's Office, 1780's-1917, No. 405262, Old Military Records Division, Record Group 94, National Archives, Washington, D.C.

⁵²Letter, John I. Rogers to Major R. Birnie, 9 November 1901, Records of the Office of the Chief of Ordnance, 1885-1915, No. 35524, Enc. 8, Old Military Records Division, Record Group 156, National Archives, Washington, D.C.

⁵³Letter, M. C. Corbin (AG) to the President of the Board of Ordnance and Fortification, 20 November 1901, Records of the Office of

the Chief of Ordnance, 1885-1915, No. 35524, Old Military Records Division Record Group 156, National Archives, Washington, D.C.

⁵⁴Philip C. Jessup, Elihu Root, 2 vols. (New York: Dodd, Meade and Company, 1938), 1:244-245.

⁵⁵Senate, "Selection of Captain Crozier," Doc. No. 387, 57th Cong., 1st sess., 1902, pp. 2, 7, 11-12, 21, 22, 33.

⁵⁶U.S., War Department, Annual Reports of the War Department for the Fiscal Year Ended June 30, 1902 (Washington, D.C.: Government Printing Office, 1902), 7:129-131.

⁵⁷Ibid., 7:167-168.

⁵⁸Ibid., 7:167.

⁵⁹"Proceedings of the Board of Ordnance and Fortification," vol. 14, Records of the War Department General and Special Staffs, Old Military Records Division, Record Group 165, National Archives, Washington, D.C., pp. 83-84.

⁶⁰George W. Burr, "The New Field Artillery," Journal of the United States Artillery 19(1903):293, 295, 298, 302.

⁶¹War Department, Annual Reports, 1902, 7:129.

⁶²Burr, "The New Field Artillery," Journal of the Artillery, pp. 299, 301.

⁶³U.S., War Department, Annual Reports of the War Department for the Fiscal Year Ended June 30, 1905 (Washington, D.C.: Government Printing Office, 1905), 9:30.

⁶⁴"Proceedings of the Board of Ordnance and Fortification," vol. 15, Records of the War Department General and Special Staffs, Old Military Records Division, Record Group 165, National Archives, Washington, D.C., p. 30.

⁶⁵C. T. Menoher, "The Panoramic Telescopic Sight," Journal of the United States Artillery 19(1903):308-310.

⁶⁶Letter, W. R. Warner to Chief of Ordnance, 29 February 1904, Records of the Office of the Chief of Ordnance, 1885-1915, No. 38545-6, Old Military Records Division, Record Group 165, National Archives, Washington, D.C.: and War Department, Annual Reports, 1904, 10:25.

⁶⁷The Germans did not equip their own field artillery with the sight until 1914. Comparato, Great Guns, p. 104.

⁶⁸"Present State of Field Artillery Rearmament," Journal of the United States Artillery 21(1904):192.

⁶⁹"Notes on Rapid-Fire Field Artillery trans. W. W. Gibson,

Journal of the United States Artillery 16(1901):145.

⁷⁰"Foreign Items of Interest," Army and Navy Journal, 12 April 1902, p. 813.

⁷¹"Present State of Field Artillery Rearmament," Journal of the United States Artillery 21(1904):191-192.

⁷²Comparato, Great Guns, p. 36.

⁷³Gabriel Rouquerol, The Tactical Employment of Quick-Firing Field Artillery, trans. F. De B. Radcliffe (London: Hugh Rees, 1903), pp. 33, 47.

⁷⁴Ibid., pp. 44, 45.

⁷⁵Spaulding, Artillery in Defense, pp. 1-2.

⁷⁶Spaulding published the first edition of his Notes on Artillery in 1908. By 1819, the book was in its fourth edition.

⁷⁷"French Guns," Army and Navy Journal, 25 August 1900, p. 1224.

⁷⁸U.S., Congress, House, Committee on Military Affairs, Army Appropriations Bill: 1905, Hearings before the Committee on Military Affairs, 58th Cong., 2d sess., 1903, p. 27.

⁷⁹U.S., Congress, House, Committee on Fortifications, The Fortification Appropriation Bill, Hearings before a subcommittee of the Committee on Appropriations, 58th Cong., 3d sess., 1904, p. 27.

⁸⁰Rouquerol, Quick-Firing Field Artillery, pp. 50-52.

⁸¹Spaulding, Notes, p. 4.

⁸²Rouquerol, Quick-Firing Field Artillery, p. 15. As Rouquerol, further observed, at one time it was thought that high explosives would add power to field artillery, but the small-caliber shells simply did not contain enough of the compound to make much difference. Ibid., pp. 20-21.

⁸³See "Howitzers and Mortars for Field Artillery, to Supply a Need of Curved Fire," Journal of the United States Artillery 10(1898):42

⁸⁴Holmes Wilson, United Service Magazine (Great Britain), cited by Army and Navy Journal, 22 August 1903, p. 1280.

⁸⁵War Department, Annual Reports, 1904, 10:26, 28.

⁸⁶Walter Fieldhouse, Fall Maneuvers, West Point, Kentucky, 1903, Report (Springfield, Illinois: Phillips Brothers, 1904), p. 20.

⁸⁷Letter, Wallace F. Randolph to the Assistant Adjutant General, 17 June 1902, Records of the Adjutant General's Office, 1780's-1917,

Number 439797, Old Military Records Division, Record Group 94, National Archives, Washington, D.C.

⁸⁸"Field Artillery Board," Army and Navy Journal, 24 January 1903, p. 494.

⁸⁹U.S., War Department, Annual Reports of the War Department for the Fiscal Year Ended June 30, 1903 (Washington, D.C.: Government Printing Office, 1903), 4:142-143.

NOTES

CHAPTER X

¹R. Ernest Dupuy, and Trevor N. Dupuy, The Encyclopedia of Military History from 3500 B.C. to the Present (New York: Harper and Row, 1970), pp. 921-925. After Mukden there were no major land battles. The war was ended by treaty, 6 September 1905.

²"New Features of War," Army and Navy Journal, 31 December 1904, pp. 460-461, citing an article by Thomas F. Millard in Scribner's Magazine for January, 1905.

³"Report of a Special Committee of the General Staff, Upon the Reorganization and Increase of the Artillery Corps of the United States Army," 5 October 1905, General Staff, 1903-1906, Field Artillery, General Correspondence, Old Military Records Division, Record Group 165, National Archives, Washington, D.C., p. 31.

⁴Ibid., p. 32.

⁵Ibid. In three fights around Port Arthur casualties due to artillery were estimated at 27 percent; and Liaoyang, 50 percent; at Shako, 33 percent; at Sandepu, 12 percent.

⁶Oliver L. Spaulding Jr., Notes on Field Artillery for Officers of All Arms (Leavenworth, Kansas: U.S. Cavalry Association, 1906), pp. 50-51.

⁷U.S., War Department, Office of the Chief of Staff, Second Division, General Staff, "Report," by Peyton C. March, Reports of Military Observers Attached to the Armies in Manchuria during the Russo-Japanese War, pt. 1 (Washington, D.C.: Government Printing Office, 1906), p. 21.

⁸Ibid., p. 19; U.S., War Department, Office of the Chief of Staff, Second Division, General Staff, "Report," by Carl Reichman, Reports of Military Observers Attached to the Armies in Manchuria during the Russo-Japanese War, pt. 1 (Washington, D.C.: Government Printing Office, 1906), p. 266; and Spaulding, Notes on Field Artillery, p. 52. The Russian gun was not as good as some Western models; it jumped some on recoil.

⁹Ibid., p. 53; and Major M. Takai, JGSDF Staff College, Tokyo, Japan, from archival research in response to interrogatives from the author.

¹⁰War Department, "Report," by March, Reports of Military Observers, p. 30; and Harry L. Hawthorne, "Heavy Caliber Cannon in the Field," Journal of the United States Artillery 29(1908):144-146.

¹¹Ibid., pp. 146-147.

¹²U.S., War Department, Office of the Chief of Staff, Second Division, General Staff, "Report" by Joseph Kuhn, Reports of Military Observers Attached to the Armies in Manchuria during the Russo-Japanese War, pt. 3 (Washington, D.C.: Government Printing Office, 1906), pp. 180-182. The 62 howitzers included 18, 28-centimeter howitzers. Several of the Japanese siege guns were obsolete, bronze pieces.

¹³Fairfax Downey, Cannonade (Garden City, New York: Doubleday and Company, 1966), p. 221.

¹⁴War Department, "Report," by Kuhn, Reports of Military Observers, pp. 181-182.

¹⁵Great Britain, Historical Section of the Committee of Imperial Defence, Official History of the Russo-Japanese War, pt. 3, The Siege of Port Arthur, pp. 161-163. Battalion commanders were apparently restricted to administrative duties.

¹⁶B. W. Norregard, The Great Siege: The Investment and Fall of Port Arthur (London: Methuen and Company, 1906), p. 138.

¹⁷War Department, "Report," by March, Report of Military Observers pp. 34-35; and War Department, "Report," by Kuhn, Report of Military Observers, pp. 180-181.

¹⁸Major Takai; and Great Britain, Historical Section, Official History, Port Arthur, p. 163.

¹⁹Major Takai.

²⁰Ernst L. Presseisen. Before Aggression: Europeans Prepare the Japanese Army, The Association for Asian Studies: Monographs and Papers, No. 21 (Tucson, Arizona: University of Arizona Press, 1965), pp. 1-3, 6, 96-97, 105.

²¹Major Takai.

²²Presseisen, Before Aggression, pp. 132-134, 139.

²³Major Takai.

²⁴See War Department, "Report," by Kuhn, Report of Military Observers, pp. 108-115.

²⁵Great Britain, Historical Section, Official History, Port Arthur, p. 156.

²⁶War Department, "Report," by Kuhn, Reports of Military

Observers, p. 186.

²⁷Norregard, The Great Siege, p. 51.

²⁸Great Britain, Historical Section, Official History, Port Arthur, p. 163.

²⁹War Department, "Report," by Reichman, Reports of the Military Observers, p. 267.

³⁰War Department, "Report," by Kuhn, Reports of the Military Observers, pp. 33-34.

³¹Ibid., p. 138.

³²See War Department, "Report," by March, Reports of the Military Observers, p. 21; War Department, "Report," by Kuhn, Reports of the Military Observers, p. 31; and Hawthorne, "Heavy Caliber Cannon," Journal of the Artillery, 29(1908):149.

³³War Department, "Report," by Reichman, Reports of the Military Observers, p. 269; and U.S., War Department, Office of the Chief of Staff Second Division, General Staff, "Report," by William Judson, Reports of Military Observers Attached to the Armies in Manchuria during the Russo-Japanese War, pt. 5 (Washington, D.C.: Government Printing Office, 1907), p. 212.

³⁴"Report of a Special Committee of the General Staff," 5 October 1905, General Staff 1903-1906, Field Artillery, p. 34.

³⁵See War Department, "Report," by March, Reports of Military Observers, pp. 21-22, 42.

³⁶H. M. Johnstone, A History of Tactics (London: Hugh Rees, 1906), p. 215.

³⁷Tiemann N. Horn, "Present Method and Lessons in Regard to Field Artillery Taught by the Russo-Japanese War," Journal of the United States Artillery 30(1908):299.

³⁸The concept of guns rapidly delivering a specified number of rounds was not abandoned. "Volley fire," as it was called, in the American, Drill Regulations for Field Artillery (Provisional), 1911 was one method of shooting. Tiemann's observation was directed at the tendency of some artillery practitioners to put excessive emphasis on the rafale.

³⁹See U.S., War Department, Office of the Chief of Staff, Second Division, General Staff, Reports by Military Observers Attached to the Armies in Manchuria during the Russo-Japanese War, pts. 1, 3, 5 (Washington, D.C.: Government Printing Office, 1906, pt. 5, 1907)

⁴⁰War Department, Annual Reports, 1904, vol. 1-4, pp. 418-420.

⁴¹Report, Board for the Preparation of Field Artillery Drill Regulations to the Chief of Artillery, 25 January 1905, Records of the Adjutant General's Office, 1780's-1917, No. 949387, Old Military Records Division, Record Group 94, National Archives, Washington, D.C., p. 2.

⁴²War Department, Annual Reports, 1904, vol. 1-4, p. 420.

⁴³Letter, Theodore Roosevelt to the Secretary of War, 1 December 1904, Records of the Adjutant General's Office, 1780's-1917, No. 949387, Old Military Records Division, Record Group 94, National Archives, Washington, D.C.

⁴⁴Letter, Secretary to the President to the Secretary of War," 9 January 1905, Records of the Adjutant General's Office, 1780's-1917, No. 949387, Old Military Records Division, Record Group 94, National Archives, Washinton, D.C.

⁴⁵"Memorandum for the Honorable, The Secretary of War," 7 February 1905, Records of the Adjutant General's Office, 1780's-1917, No. 949387, Old Military Records Division, Record Group 94, National Archives, Washington, D.C., p. 6.

⁴⁶Letter, Theodore Roosevelt to the Secretary of War, 9 February 1905, Records of the Adjutant General's Office, 1780's-1917, No. 949387, Old Military Records Division, Record Group 94, National Archives, Washington, D.C.

⁴⁷War Department, Annual Reports, 1904, vol. 1-4, p. 429.

⁴⁸Letter, Secretary of War to the President, 13 January 1905, Records of the Adjutant General's Office, 1780's-1917, No. 949387, Old Military Records Division, Record Group 94, National Archives, Washington, D.C.

⁴⁹Letter, Chief of Artillery to the Military Secretary, 7 June 1905, Records of the Adjutant General's Office, 1780's-1917, No. 1023341, Old Military Records Division, Record Group 94, National Archives, Washington, D.C.

⁵⁰War Department, Annual Reports, 1904, vols. 1-4, pp. 14-16.

⁵¹U.S., War Department, Annual Reports of the War Department for the Fiscal Year Ended June 30, 1905 (Washington, D.C.: Government Printing Office, 1905), 1:24-25.

⁵²Report, Chief of Artillery to the Chief of Staff, 17 June 1905, Office of the Chief of Artillery, General Correspondence, 1901-1917, No. 4489, Old Military Records Division, Record Group 77, National Archives, Washington, D.C., p. 4.

⁵³Ibid., pp. 16-17.

⁵⁴Letter, Chief of Artillery to the Chief of Staff, 26 April 1905,

General Staff, 1903-1906, Field Artillery, General Correspondence, Old Military Records Division, Record Group 165, National Archives, Washington, D.C.

⁵⁵Memorandum Report, First Division General Staff, 5 May 1905, General Staff, 1903-1906, Field Artillery, General Correspondence, Old Military Records Division, Record Group 165, National Archives, Washington, D.C., pp. 3-5, 8. The dispute over a proper ratio was initially complicated by a failure of the arguing parties to sufficiently define their terms. The basis of calculation was variously described as a certain number of guns to troops, to infantry, and to infantry and cavalry. The result was a confusion of conflicting calculations. The final figures were based on the number of guns per 1,000 infantry.

⁵⁶The figures for Great Britain were not available to the planners. Ibid., p. 10.

⁵⁷Report, Board for the Preparation of Field Artillery Drill Regulations to the Chief of Artillery, 25 January 1905, Adjutant General's Office, No. 949387.

⁵⁸Letter, Chief of Artillery to the Military Secretary, 7 June 1905, Adjutant General's Office, No. 1023341.

⁵⁹U.S., War Department, General Orders Number 89, 14 June 1905.

⁶⁰Letter, Capt. T. C. Dickson to the Commanding Officer, Frankford Arsenal, 2 May 1905, Records of the Chiefs of Arms, Field Artillery Board, 1904-1939, Old Military Records Division, Record Group 177, National Archives, Washington, D.C.

⁶¹War Department, Annual Reports, 1905, 2:242.

⁶²U.S., War Department, Annual Reports of the War Department for the Fiscal Year Ended 30 June 1908 (Washington, D.C.: Government Printing Office, 1908), 2:1991.

⁶³B. P. Joyce, "New 'Four--Point--Seven' Guns," The Field Artillery Journal 12(1922):73; and U.S., War Department, Ordnance Department, Handbook of the 3.8-Inch Gun Materiel (Washington, D.C.: Government Printing Office, 1917), p. 17.

⁶⁴War Department, Annual Reports, 1904, 10:27. The Ordnance Department was at work on a 2.38-inch field gun for use around coast defenses; but Crozier was careful to mention that the piece was being built on the recommendation of the Board of Ordnance and Fortification. In 1907, Crozier openly cast doubt on the utility of such a light round, and that seems to have killed the project. U.S., War Department, Annual Reports of the War Department for the Fiscal Year Ended 30 June 1907 (Washington, D.C.: Government Printing Office, 1907), 6:44

⁶⁵War Department, Annual Reports, 1905, 9:31.

⁶⁶Ibid., 9:31-32.

⁶⁷U.S., War Department, Annual Reports of the War Department for the Fiscal Year Ended 30 June 1909 (Washington, D.C.: Government Printing Office, 1910), 6:30.

⁶⁸U.S., War Department, Annual Reports of the War Department for the Fiscal Year Ended 30 June 1903 (Washington, D.C.: Government Printing Office, 1903), 14:15.

⁶⁹War Department, Annual Reports, 1904, 10:26-27.

⁷⁰U.S., War Department, Annual Reports of the War Department for the Fiscal Year Ended 30 June 1906 (Washington, D.C.: Government Printing Office, 1906), vols. 6-7, p. 30.

⁷¹War Department, Annual Reports, 1908, 1:43, 366. Crozier used funds credited to the Department from sales of small arms to the militia.

⁷²Ibid., 2:254.

⁷³War Department, Annual Reports, 1907, 1:177.

⁷⁴War Department, Annual Reports, 1908, 1:253.

⁷⁵War Department, Annual Reports, 1907, 2:217.

⁷⁶Ibid.

⁷⁷Ibid.

⁷⁸See U.S., War Department, Drill Regulations for Field Artillery, United States Army (Provisional) (Washington, D.C.: Government Printing Office, 1907), and compare with U.S., War Department, Drill Regulations for Mountain Artillery (Provisional), United States Army, 1908 (Washington, D.C.: Government Printing Office, 1908).

⁷⁹War Department, Annual Reports, 1908, 2:217-218.

⁸⁰"Redoubt Firing at Fort Riley," Army and Navy Journal, 14 September 1907, p. 43.

⁸¹"Fort Riley Artillery Experiments," Army and Navy Journal, 28 September 1907, pp. 92-93.

⁸²War Department, Annual Reports, 1909, 6:30.

⁸³War Department, Annual Reports, 1907, 6:44.

⁸⁴U.S., War Department, Annual Reports of the War Department for the Fiscal Year Ended 30 June 1912 (Washington, D.C.: Government Printing Office, 1913), 1:107.

BIBLIOGRAPHY

A. PRIMARY SOURCES

1. Manuals

Artillery Tactics United States Army, Assimilated to the Tactics of Infantry and Cavalry. New York: D. Appleton and Company, 1874.

Dyer, Alexander B. Handbook for Light Artillery, 4th ed. New York: John Wiley and Sons, 1896.

Frank, William H; Barry, William F.; Hunt, Henry J. Instruction for Field Artillery. Washington, D.C.: Government Printing Office, 1864.

Halleck, Henry W. Elements of Military Art and Science: or Course of Instruction in Strategy, Fortification Tactics of Battles; Embracing the Duties of Staff, Infantry, Cavalry, Artillery, and Engineers. New York: D. Appleton and Company, 1859.

Instruction for Heavy Artillery: Prepared by a Board of Officers for the Use of the Army of the United States. Charleston, S.C.: Evans and Cogswell, 1861.

Mahan, Dennis Hart. A Complete Treatise on Field Fortification, with the General Outlines of the Principles Regulating the Arrangement, the Attack, and the Defense of Permanent Works. n.p.: originally published by Wiley and Long, 1836, reprint edition, by the West Point Military Library Series. New York: Greenwood Press, 1968.

. An Elementary Treatise on Advance-Guard, Out-Post and Detachment Service of Troops, and the Manner of Posting and Handling Them in Presence of an Enemy. New York: John Wiley, 1853.

U.S. War Department. Drill Regulations for Field Artillery, United States Army (Provisional). Washington, D.C.: Government Printing Office, 1907.

U.S. War Department. Drill Regulations for Light Artillery, United States Army. Washington, D.C.: Government Printing Office, 1896.

U.S. War Department. Drill Regulations for Mountain Artillery (Provisional) United States Army, 1908. Washington, D.C.: Government Printing Office, 1908.

- U.S. Congress. House. Report of the Board of Ordnance and Fortification.
Ex. Doc. No. 12, 52d Cong., 2d sess., 1892.
- U.S. Congress. House. Report of the Board on Fortifications or
Other Defenses. Ex. Doc. No. 49, 49th Cong., 1st sess., 1896.
- U.S. Congress. House. Report of the Committee on Military Affairs.
Report No. 384, 43d Cong., 1st sess., 1874.
- U.S. Congress. House. Report of the Gun Foundry Board. Ex. Doc.
No. 97, 48th Cong., 1st sess., 1884.
- U.S. Congress. House. Report of the Secretary of War. Ex. Doc. No. 1,
41st Cong., 2d sess., 1869, pt. 2, vol. 1.
- U.S. Congress. House. Report of the Secretary of War. Ex. Doc. No. 1,
41st Cong., 3d sess., pt. 2, 1870, vol. 1.
- U.S. Congress. House. Report of the Secretary of War. Ex. Doc. No. 1,
42d Cong., 2d sess., 1871, pt. 2, vol. 1.
- U.S. Congress. House. Report of the Secretary of War. Ex. Doc. No. 1,
42d Cong., 3d sess., 1872, pt. 2, vol. 1.
- U.S. Congress. House. Report of the Secretary of War. Ex. Doc. No. 1,
43d Cong., 1st sess., 1873, pt. 2, vol. 3.
- U.S. Congress. House. Report of the Secretary of War. Ex. Doc. No. 1,
43d Cong., 2d sess., 1874, pt. 2, vol. 1.
- U.S. Congress. House. Report of the Secretary of War. Ex. Doc. No. 1,
44th Cong., 1st sess., 1875, pt. 2, vol. 3.
- U.S. Congress. House. Report of the Secretary of War. Ex. Doc. No. 1,
44th Cong., 2d sess., 1876, pt. 2, vol. 3.
- U.S. Congress. House. Report of the Secretary of War. Ex. Doc. No. 1,
45th Cong., 2d sess., 1877, pt. 2, vol. 3.
- U.S. Congress. House. Report of the Secretary of War. Ex. Doc. No. 1,
46th Cong., 2d sess., 1879, pt. 2, vol. 1.
- U.S. Congress. House. Report of the Secretary of War. Ex. Doc. No. 1,
46th Cong., 2d sess., 1879, pt. 2, vol. 3.
- U.S. Congress. House. Report of the Secretary of War. Ex. Doc. No. 1,
46th Cong., 3d sess., 1880, pt. 2, vol. 3.
- U.S. Congress. House. Report of the Secretary of War. Ex. Doc. No. 1,
50th Cong., 2d sess., 1888, pt. 2, vol. 1,
- U.S. Congress. House. Report of the Secretary of War. Ex. Doc. No. 1,
51st Cong., 1st sess., 1889, pt. 2, vol. 1.

U.S. War Department. Light Artillery Drill Regulations, United States Army, 1891. Washington, D.C.: Government Printing Office, 1891.

U.S. War Department. Troops in Campaign, Regulations for the Army of the United States. Washington, D.C.: Government Printing Office, 1892.

2. United States Government Documents

U.S. Department of the Army. The Army Almanac: a Book of Facts Concerning the Army of the United States. Washington, D.C.: Government Printing Office, 1950.

U.S. Department of the Army. Combat Operations Research Group (CORG). Evolution of the United States Army Field Manual, by Virgil Ney. CORG-M-244. Memorandum for Headquarters United States Army Combat Developments Command, 1966.

U.S. Congress. House. Annual Reports of the War Department for the Fiscal Year Ended June 30, 1900, Report of the Chief of Ordnance. Doc. No. 2, 56th Cong., 2d sess., 1900.

U.S. Congress. House. "Coast Defenses." Mis. Doc. No. 109, 49th Cong., 2d sess., 1887.

U.S. Congress. House. "Letter of the Secretary of War." Ex. Doc. No. 56, 41st Cong., 3d sess., 1876.

U.S. Congress. House. "Letter from the Secretary of War." Ex. Doc. No. 89, 42d Cong., 2d sess., 1872.

U.S. Congress. House. "Letter from the Secretary of War." Ex. Doc. No. 69, 43d Cong., 1st sess., 1874.

U.S. Congress. House. Message of the President of the United States and Accompanying Documents. Ex. Doc. No. 1, 40th Cong., 3d sess, 1867.

U.S. Congress. House. Message of the President of the United States and Accompanying Documents. Ex. Doc. No. 1, 40th Cong., 3d sess, 1868.

U.S. Congress. House. Ordnance and Ordnance Stores. Mis. Doc. No. 152, 40th Cong., 2d sess., 1868.

U.S. Congress. House. Reorganization of Army. Rpt. 1709, 55th Cong., 3d sess., 1898, pt. 1.

U.S. Congress. House. Report. Report No. 46, 42d Cong., 2d sess., 1872.

U.S. Congress. House. Report. Report No. 74, 42d Cong., 3d sess., 1873.

- U.S. Congress. House. Report of the Secretary of War. Ex. Doc. No. 1, 52d Cong., 2d sess., 1892, pt. 2, vol. 1,
- U.S. Congress. House. "Views of the Minority." Report No. 46, 42d Cong 2d sess., 1872, pt. 2.
- U.S. Congress. House. Committee on Appropriations. The Fortification Appropriation Bill, Hearings, before a Subcommittee of the Committee on Appropriations. 54th Cong., 1st sess., 1896.
- U.S. Congress. House. Committee on Fortifications. The Fortification Appropriation Bill, Hearings before a Subcommittee of the Committee on Appropriations, 58th Cong., 3d sess., 1904.
- U.S. Congress. House. Committee on Military Affairs. Army Appropriations Bill: 1905, Hearings before the Committee on Military Affairs, 58th Cong., 2d sess., 1903.
- U.S. Congress. Senate. Evidence Taken Before the Committee on Appropriations of the Senate. Mis. Doc. No. 44, 47th Cong., 1st sess., 1882.
- U.S. Congress. Senate. "Letter of the Secretary of War." Ex. Doc. No. 81, 40th Cong., 2d sess., 1868.
- U.S. Congress. Senate. Report. Rep Com. No. 121, 38th Cong., 2d sess., 1865.
- U.S. Congress. Senate. Report. Rep. Com. No. 165, 39th Cong., 2d sess, 1867.
- U.S. Congress. Senate. Report. Rep. Com. No. 173, 40th Cong., 2d sess, 1868.
- U.S. Congress. Senate. Report. Rep. Com. No. 266, 40th Cong., 3d sess., 1869.
- U.S. Congress. Senate. Report. Report No. 183, 42d Cong., 2d sess., 1872.
- U.S. Congress. Senate. Report of the Board on Heavy Ordnance and Projectiles. Ex. Doc. No. 178, 44th Cong., 1st sess., 1882.
- U.S. Congress. Senate. Report of the Commission Appointed by the President to Investigate the Conduct of the War Department in the War with Spain, vol. 1, Doc. No. 221, 56th Cong., 1st sess., 1900.
- U.S. Congress. Senate. "Resolution." Mis. Doc. No. 73, 42d Cong., 2d sess., 1872.
- U.S. Congress. Senate. "Selection of Captain Crozier for Chief of Ordnance." Doc. No. 387, 57th Cong., 1st sess., 1902.

- U.S. War Department. Annual Report of the Secretary of War for the Year 1881, vol. 1. Washington, D.C.: Government Printing Office, 1881.
- U.S. War Department. Annual Report of the Secretary of War for the Year 1882, vol. 3. Washington, D.C.: Government Printing Office, 1882.
- U.S. War Department. Annual Report of the Secretary of War for the Year 1882, vol. 3. Washington, D.C.: Government Printing Office, 1883.
- U.S. War Department. Annual Report of the Secretary of War for the Year 1885, vol. 3. Washington, D.C.: Government Printing Office, 1885.
- U.S. War Department. Annual Report of the Secretary of War for the Year 1887, pt. 2, vol. 4. Washington, D.C.: Government Printing Office, 1887.
- U.S. War Department. Annual Report of the Secretary of War for the Year 1889, vol. 3. Washington, D.C.: Government Printing Office, 1889.
- U.S. War Department. Annual Report of the Secretary of War for the Year 1890, vol. 1. Washington, D.C.: Government Printing Office, 1890.
- U.S. War Department. Annual Report of the Secretary of War for the Year 1891, vol. 3. Washington, D.C.: Government Printing Office, 1892.
- U.S. War Department. Annual Report of the Secretary of War for the Year 1892, vol. 1. Washington, D.C.: Government Printing Office, 1892.
- U.S. War Department. Annual Report of the Secretary of War for the Year 1893, vol. 3. Washington, D.C.: Government Printing Office, 1893.
- U.S. War Department. Annual Report of the Secretary of War for the Year 1894, vol. 1. Washington, D.C.: Government Printing Office, 1894.
- U.S. War Department. Annual Report of the Secretary of War for the Year 1895, vol. 3. Washington, D.C.: Government Printing Office, 1896.
- U.S. War Department. Annual Report of the Secretary of War for the Year 1896, vol. 3. Washington, D.C.: Government Printing Office, 1897.
- U.S. War Department. Annual Reports of the War Department for the Fiscal Year Ended June 30, 1897, Report of the Chief of

- Ordnance. Washington, D.C.: Government Printing Office, 1897.
- U.S. War Department. Annual Reports of the Secretary of War for the Fiscal Year Ended June 30, 1898, vol. 1. Washington, D.C.: Government Printing Office, 1898.
- U.S. War Department. Annual Reports of the Secretary of War for the Fiscal Year Ended June 30, 1898, vol. 3. Washington, D.C.: Government Printing Office, 1899.
- U.S. War Department. Annual Reports of the War Department for the Fiscal Year Ended June 30, 1899, vol. 1, pt. 3. Washington, D.C.: Government Printing Office, 1899.
- U.S. War Department. Annual Reports of the War Department for the Fiscal Year Ended June 30, 1900, vol. 1, pt. 1. Washington, D.C.: Government Printing Office, 1900.
- U.S. War Department. Annual Reports of the War Department for the Fiscal Year Ended June 30, 1901, vol. 3. Washington, D.C.: Government Printing Office, 1902.
- U.S. War Department. Annual Reports of the War Department for the Fiscal Year Ended June 30, 1902, vol. 3. Washington, D.C.: Government Printing Office, 1902.
- U.S. War Department. Annual Reports of the War Department for the Fiscal Year Ended June 30, 1902, vol. 7. Washington, D.C.: Government Printing Office, 1902.
- U.S. War Department. Annual Reports of the War Department for the Fiscal Year Ended June 30, 1903, vol. 4. Washington, D.C.: Government Printing Office, 1903.
- U.S. War Department. Annual Reports of the War Department for the Fiscal Year Ended 30 June 1903, vol. 14. Washington, D.C.: Government Printing Office, 1903.
- U.S. War Department. Annual Reports of the War Department for the Fiscal Year Ended June 30, 1904, vol. 10. Washington, D.C.: Government Printing Office, 1904.
- U.S. War Department. Annual Reports of the War Department for the Fiscal Year Ended June 30, 1905, vol. 1. Washington, D.C.: Government Printing Office, 1905.
- U.S. War Department. Annual Reports of the War Department for the Fiscal Year Ended June 30, 1905, vol. 9. Washington, D.C.: Government Printing Office, 1905.
- U.S. War Department. Annual Reports of the War Department for the Fiscal Year Ended 30 June 1906, vols. 6-7. Washington, D.C.: Government Printing Office, 1906.

- U.S. War Department. Annual Reports of the War Department for the Fiscal Year Ended 30 June 1907, vol. 6. Washington, D.C.: Government Printing Office, 1907.
- U.S. War Department. Annual Reports of the War Department for the Fiscal Year Ended 30 June 1908, vol. 2. Washington, D.C.: Government Printing Office, 1908.
- U.S. War Department. Annual Reports of the War Department for the Fiscal Year Ended 30 June 1909, vol. 6. Washington, D.C.: Government Printing Office, 1910.
- U.S. War Department. Annual Reports of the War Department for the Fiscal Year Ended 30 June 1912, vol. 1. Washington, D.C.: Government Printing Office, 1913.
- U.S. War Department. Fourth Report of the Board of Ordnance and Fortification to the Secretary of War. Washington, D.C.: Government Printing Office, 1894.
- U.S. War Department. Fifth Report of the Board of Ordnance and Fortification. Washington, D.C.: Government Printing Office, 1895.
- U.S. War Department. Sixth Report of the Board of Ordnance and Fortification. Washington, D.C.: Government Printing Office, 1896.
- U.S. War Department. Ninth Report of the Board of Ordnance and Fortification. Washington, D.C.: Government Printing Office, 1899.
- U.S. War Department. Tenth Report of the Board of Ordnance and Fortification. Washington, D.C.: Government Printing Office, 1900.
- U.S. War Department. Eleventh Report of the Board of Ordnance and Fortification. Washington, D.C.: Government Printing Office, 1901.
- U.S. War Department. Fourteenth Report of the Board of Ordnance and Fortification. Washington, D.C.: Government Printing Office, 1904.
- U.S. War Department. General Orders Number 144, 9 October 1865.
- U.S. War Department. General Orders Number 151, 16 October 1865.
- U.S. War Department. General Orders Number 6, 30 January 1866.
- U.S. War Department. General Orders Number 73, 1 August 1867.
- U.S. War Department. General Orders Number 99, 13 November 1867.

- U.S. War Department. General Orders Number 101, 26 November 1867.
- U.S. War Department. General Orders Number 6, 18 February 1869.
- U.S. War Department. General Orders Number 28, 27 March 1869.
- U.S. War Department. General Orders Number 51, 15 May 1869.
- U.S. War Department. General Orders Number 69, 6 August 1869.
- U.S. War Department. General Orders Number 46, 15 June 1872.
- U.S. War Department. General Orders Number 89, 21 October 1875.
- U.S. War Department. General Orders Number 92, 10 November 1875.
- U.S. War Department. General Orders Number 48, 16 May 1881.
- U.S. War Department. General Orders No. 39, 28 April 1881.
- U.S. War Department. General Orders Number 26, 13 March 1885.
- U.S. War Department. General Orders Number 89, 14 June 1905.
- U.S. War Department. Message of the President of the United States, and Accompanying Documents. Ex. Doc. No. 1, 39th Cong., 1st sess., 1866.
- U.S. War Department. Report of the Secretary of War, 1878, vol. 3. Washington, D.C.: Government Printing Office, 1878.
- U.S. War Department. War of the Rebellion: A Compilation of the Official Records of the Union and Confederate Armies, series 1, vol. 5. Washington, D.C.: Government Printing Office, 1881.
- U.S. War Department. War of the Rebellion: A Compilation of the Official Records of the Union and Confederate Armies, series 1, vol. 11, pt. 2. Washington, D.C.: Government Printing Office, 1881.
- U.S. War Department. War of the Rebellion: A Compilation of the Official Records of the Union and Confederate Armies, series 1, vol. 25, pt. 2. Washington, D.C.: Government Printing Office, n.d.
- U.S. War Department. War of the Rebellion: A Compilation of the Official Records of the Union and Confederate Armies, series 1, vol. 27, pt. 2. Washington, D.C.: Government Printing Office, 1889.
- U.S. War Department. War of the Rebellion: A Compilation of the Official Records of the Union and Confederate Armies, series 1, vol. 36, pt. 1. Washington, D.C.: Government Printing Office, 1891.

- U.S. War Department. Adjutant General's Office. Artillery Circular I, Series of 1893: Modern Guns and Mortars. Washington, D.C.: Government Printing Office, 1895.
- U.S. War Department. Artillery School. "Changes Wrought in Artillery in the Nineteenth Century, and Their Effect Upon the Attack and Defense of Fortified Pieces," essay by Lieutenant Henry R. Lemly. Fort Monroe, Virginia: the Artillery School, 1886.
- U.S. War Department. Artillery School "Comparisons of the Armaments of European Nations, Describing Their Systems of Artillery," essay by Alexander D. Schenck. Fort Monroe, Virginia: Artillery School Press, 1886.
- U.S. War Department. Artillery School. Essays of the Department of Artillery, "Steel as a Gun Metal," by Adam Slaker. Fort Monroe, Virginia: Artillery School Press, 1892.
- U.S. War Department. Artillery School. "Material for Field Artillery for the United States Army," essey by Alexander D. Schenck. Fort Monroe, Virginia: Artillery School, 1886.
- U.S. War Department. Military Infromation Division, The Military System of Sweden and Other Papers Selected for Publication. Washington, D.C.: Government Printing Office, 1896.
- U.S. War Department. Office of the Chief of Staff. Second Division, General Staff. Selected Translations Pertaining to the Boer War. "Notes on the Axtillery in the South African War," by P. van Berchem. Washington, D.C.: Government Printing Office, 1905.
- U.S. War Department. Office of the Chief of Staff. Second Division, General Staff. "Report," by Carl Reichman. Reports of the Military Observers Attached to the Armies in Manchuria during the Russo-Japanese War, pt. 1. Washington, D.C.: Government Printing Office, 1906.
- U.S. War Department. Office of the Chief of Staff. Second Division, General Staff. "Report," by Joseph Kuhn. Reports of Military Observers Attached to the Armies in Manchuria during the Russo-Japanese War, pt. 3. Washington, D.C.: Government Printing Office, 1906.
- U.S. War Department. Office of the Chief of Staff. Second Division, General Staff. "Report," by Peyton G. March. Reports of Military Observers Attached to the Armies in Manchuria during the Russo-Japanese War, pt. 1. Washington, D.C.: Government Printing Office, 1906.
- U.S. War Department. Office of the Chief of Staff. Second Division, General Staff. "Report," by William Judson. Reports of Military Observers Attached to the Armies in Manchuria during

the Russo-Japanese War, pt. 5. Washington, D.C.: Government Printing Office, 1907.

U.S. War Department. Ordnance Department. A Collection of Ordnance Reports and Other Important Papers Relating to the Ordnance Department, 4 vols. Washington, D.C.: Government Printing Office, 1890.

U.S. War Department. Ordnance Department. Gun Making in the United States, by Rogers Birnie. Washington, D.C.: Government Printing Office, 1907.

U.S. War Department. Ordnance Department. Handbook of the 3.8-Inch Gun Materiel. Washington, D.C.: Government Printing Office, 1917.

U.S. War Department. Ordnance Department. The Ordnance Department as a Portion of the United States Military Establishment: Being a Historical Statement of the Rise and Progress of the Ordnance Department to the Secretary of War and Army Proper. Washington, D.C.: n.p., 1876.

U.S. War Department. Ordnance Office. Ordnance Notes, Nos. 1 to 40. Washington, D.C.: n.p., n.d.

U.S. War Department. Ordnance Office. Ordnance Notes, Nos. 68 to 100. Washington, D.C.: n.p., n.d.

3. Unpublished Material

Washington, D.C. National Archives. Old Military Records Division. Record Group 77. Office of the Chief of Artillery, General Correspondence, 1901-1917.

Washington, D.C. National Archives. Old Military Records Division. Record Group 94. Records of the Adjutant General's Office, 1780's-1917.

Washington, D.C. National Archives. Old Military Records Division. Record Group 94. Records of the Adjutant General's Office. Letters Received by the Adjutant General's Office, 1801-70, Microcopy No. M-619, "Proceedings of a Board to devise and report on a system of 'Artillery Tactics,' 1868."

Washington, D.C. National Archives. Old Military Records Division. Record Group 94. Records of the Adjutant General's Office. Letters Received by the Adjutant General's Office, 1801-70, Microcopy No. M-619, "Schofield Board Report."

Washington, D.C. National Archives. Old Military Records Division. Record Group 94. Records of the Adjutant General's Office 1780's-1917. Letters Received by the Office of the Adjutant General, Main Series, 1881-1889, Microcopy No. M-689.

"Proceedings of the 1888 Board."

Washington, D.C. National Archives. Old Military Records Division.
Record Group 156. Records of the Chief of Ordnance, General
Correspondence, 1885-1915.

Washington, D.C. National Archives. Old Military Records Division.
Record Group 165. Board of Ordnance and Fortification, General
Correspondence, 1888-1919.

Washington, D.C. National Archives. Old Military Records Division.
Record Group 165. General Staff, General Correspondence,
1903-1906.

Washington, D.C. National Archives. Old Military Records Division.
Record Group 165. Records of the War Department General and
Special Staffs. "Proceedings of the Board of Ordnance and
Fortifications," vols. 1-12.

Washington, D.C. National Archives. Old Military Records Division.
Record Group 177. Records of the Chiefs of Arms, Field Artillery
Board, 1904-1939.

4. Other

Great Britain. Historical Section of the Committee of Imperial Defence.
Official History of the Russo-Japanese War. Pt. 3, The Siege
of Port Arthur.

Japan. Archival research done by Major M. Takai, JGSD Staff College,
Tokyo, in response to interrogatives from the author.

B. SECONDARY SOURCES

1. Books

Birkhimer, William E. Historical Sketch of the Organization,
Administration, Materiel, and Tactics of the Artillery, United
States Army. Washington, D.C.: James J. Chapman, 1884.

Blaine, James G. Twenty Years of Congress: From Lincoln to Garfield.
2 vols. Norwich, Connecticut: Henry Bill Publishing Company,
1886.

Chandler, David G. The Campaigns of Napoleon. New York: The Macmillan
Company, 1966.

Comparato, Frank E. Age of Great Guns: Cannon Kings and Cannoneers
Who Forged the Firepower of Artillery. Harrisburg, Pennsylvania:
Stackpole Company, 1965.

- Downey, Fairfax. Cannonade: Great Artillery Actions of History. Garden City, New York: Doubleday and Company, 1966.
- . Sound of the Guns: The Story of American Artillery from the Ancient and Honorable Company to the Atom Cannon and Guided Missile. New York: David McKay Company, 1956.
- Dupuy, R. Ernest, and Dupuy, Trevor N. The Encyclopedia of Military History from 3500 B.C. to the Present. New York: Harper and Row, 1970.
- Esposito, Vincent J. and Elting, John R. A Military History and Atlas of the Napoleonic Wars. New York: Frederick A. Praeger, 1964.
- Fieldhouse, Walter, Fall Maneuvers, West Point, Kentucky, 1903, Report. Springfield, Illinois: Phillips Brothers, 1904.
- Freeman, Douglas Southall. R. E. Lee. 4 vols. New York: Charles Scribner's Sons, 1934.
- Fuller, Claud E. The Rifled Musket. New York: Bonanza Books, 1958.
- Grant, Ulysses S. Personal Memoirs of U. S. Grant. New York: Charles L. Webster and Company, 1886.
- Howard, Michael. The Franco-Prussian War. n.p.: Macmillan Company, Collier Books, 1969, first copyright 1961.
- Jessup, Philip C. Elihu Root. 2 vols. New York: Dodd, Meade and Company, 1938.
- Johnstone, H. M. A History of Tactics. London: Hugh Rees, 1906.
- Kuhn, Thomas S. The Structure of Scientific Revolution. Chicago: University of Chicago Press, 1970.
- Matloff, Maurice, ed. American Military History. Washington, D.C.: Office of the Chief of Military History, 1959, partially revised 1973.
- Naisawald, L. Van Loan. Grape and Canister: The Story of the Field Artillery of the Army of the Potomac, 1861-1865. New York: Oxford University Press, 1960.
- Nevins, Allan. Hamilton Fish: The Inner History of the Grant Administration. New York: Dodd, Mead and Company, 1936.
- Norregard, B. W. The Great Siege: The Investment and Fall of Port Arthur. London: Methuen and Company, 1906.
- Presseisen, Ernst L. Before Aggression: Europeans Prepare the Japanese Army. The Association for Asian Studies: Monographs and Papers, No. 21. Tucson, Arizona: University of Arizona Press, 1965.

- Richardson, James D. A Compilation of the Messages and Papers of the President. 20 vols. (n.p.: Bureau of National Literature, 1897), vol. 10.
- Ripley, Warren. Artillery and Ammunition of the Civil War. New York: Promontory Press, 1970.
- Rodenbough, Theophilos F. and Haskin William L., editors. The Army of the United States: Historical Sketches of Staff and Line with Portraits of Generals-in-Chief. New York: Arno Press, 1966.
- Rouquerol, Gabriel. The Tactical Employment of Quick-Firing Field Artillery. Translated by F. De B. Radcliffe. London: Hugh Rees, 1903.
- Spaulding, Oliver L. Artillery in Defense. Fort Leavenworth, Kansas: Staff College Press, 1904.
- _____. Notes on Field Artillery for Officers of All Arms. Leavenworth, Kansas: U.S. Cavalry Association, 1906.
- The Santiago Campaign. Richmond, Virginia: Williams Printing Company, 1927.
- Trotha, Thilo von. Tactical Studies of the Battles Around Plevna. Translated by Carl Reichman. Arthur L. Wagner, editor. International Series, no. 3. Kansas City, Missouri: Hudson-Kimberly Company, 1896.
- Wagner, Arthur L. Organization and Tactics. New York: B. Westermann and Co., 1895.
- Wise, Jennings Cropper. The Long Arm of Lee: The History of the Artillery of the Army of Northern Virginia, with a Foreward by L. Van Loan Naisawald. New York: Oxford University Press, 1959.
- Weigley, Russell F. History of the United States Army. New York: The Macmillan Company, 1967.

2. Periodicals (by publication and date)

- "French Study of Artillery." Army and Navy Journal, 29 April 1865, p. 586.
- "Siege Artillery at Petersburg [sic]." Army and Navy Journal, 30 September 1865, p. 83.
- "French and German Artillery." Army and Navy Journal, 24 September 1870, p. 86.
- Army and Navy Journal, 29 October 1870, p. 1.
- Army and Navy Journal, 19 November 1870, p. 218.

- "A Few Thoughts on Artillery." Army and Navy Journal, 15 July 1871, p. 768.
- "A Few Thoughts on the Artillery." Army and Navy Journal, 9 September 1871, pp. 65-68.
- "The Ordnance and Artillery." Army and Navy Journal, 16 September 1871, p. 78.
- "Smokeless Gunpowder." Army and Navy Journal, 26 October 1872, p. 174.
- "The Shielded Gatling." Army and Navy Journal, 29 November 1872, p. 254
- Army and Navy Journal, 25 October 1873, p. 74.
- Army and Navy Journal, 8 November 1873, p. 206.
- Army and Navy Journal, 29 November 1873, p. 245.
- "Pointing Heavy Guns." Army and Navy Journal, 9 May 1874, p. 618.
- "The New Eighty-One Ton Gun." Army and Navy Journal, 16 May 1874, p. 631.
- "Rapid Field Entrenchments." Army and Navy Journal, 11 July 1874, p. 766.
- "Modern Weapons and Modern Tactics." Army and Navy Journal, 1 August 1874, p. 807.
- Army and Navy Journal, 11 September 1875, p. 78.
- Army and Navy Journal, 26 September 1874, p. 111.
- Army and Navy Journal, 8 April 1876, p. 571.
- "Artillery Grand Tactics." Army and Navy Journal, 20 May 1876, p. 662.
- Army and Navy Journal, 8 June 1876, p. 358.
- "The One Hundred Ton Gun." Army and Navy Journal, 2 September 1876, p. 59.
- Army and Navy Journal, 7 October 1876, p. 142.
- "The Eyes of the Artillery." Army and Navy Journal, 4 November 1876, p. 197.
- Army and Navy Journal, 4 November 1876, p. 207.
- Army and Navy Journal, 6 January 1877, p. 350.
- "Foreign Items." Army and Navy Journal, 20 January 1877, p. 383.
- Army and Navy Journal, 3 March 1877, p. 486.

- "Artillery Practice at Cronstadt." Army and Navy Journal, 7 April 1877, p. 562.
- Army and Navy Journal, 29 September 1877, p. 121.
- Army and Navy Journal, 29 September 1877, p. 334.
- Army and Navy Journal, 13 October 1877, p. 150.
- Army and Navy Journal, 29 December 1877, p. 334.
- "The Modern Breechloader." Army and Navy Journal, 13 April 1878, p. 571.
- "The Breechloader in Warfare." Army and Navy Journal, 13 April 1878, p. 575.
- "Aligning Guns Under Cover." Army and Navy Journal, 25 May 1878, p. 836.
- "Power of Chambered Guns." Army and Navy Journal, 17 August 1878, p. 30
- "The Problem of Naval Guns." Army and Navy Journal, 11 January 1879, p. 396.
- Army and Navy Journal, 12 September 1879, p. 133.
- "The Thunderer Gun Trials." Army and Navy Journal, 7 February 1880, p. 544.
- "Foreign Intelligence." Army and Navy Journal, 28 August 1880, p. 74.
- "French Portable Field Telephone." Army and Navy Journal, 5 February 1881, p. 551.
- "Guns for the Army and Navy." Army and Navy Journal, 12 February 1881, p. 571.
- "The Mixed Ordnance Board." Army and Navy Journal, 2 April 1881, p. 730
- Army and Navy Journal, 12 November 1881, p. 323.
- Army and Navy Journal, 17 December 1881, p. 435.
- "The Light Artillery Board." Army and Navy Journal, 8 October 1881, p. 115
- "The Dynamite Gun." Army and Navy Journal, 5 April 1884, p. 733.
- "American Guns." Army and Navy Journal, 21 June 1884, p. 965.
- "Brown Powder." Army and Navy Journal, 6 September 1884, p. 110.
- "The Hotchkiss Cannon." Army and Navy Journal, 24 September 1887, p. 167.

- "Ordnance Notes." Army and Navy Journal, 7 June 1890, p. 786.
- "The New Field Guns." Army and Navy Journal, 26 December 1891, p. 313.
- "The Rapid-Fire Field and Landing Gun." Army and Navy Journal,
8 December 1894, p. 247.
- "Prospects for Army Legislation." Army and Navy Journal, 7 March
1897, p. 474.
- "Increasing the Artillery." Army and Navy Journal, 2 October 1897,
p. 72.
- "Artillery Bill Passes the Senate." Army and Navy Journal, 26 February
1898, p. 474.
- "The New Artillery Regiments." Army and Navy Journal, 12 March 1898,
p. 513.
- "Results of the Santiago Battles." Army and Navy Journal, 23 July
1898, p. 952.
- "The Artillery at San Juan." Army and Navy Journal, 19 November 1898,
p. 274.
- "Honor to the Artillery." Army and Navy Journal, 28 January 1899,
p. 516.
- "The Artillery at Santiago." Army and Navy Journal, 27 May 1899,
p. 923.
- "Secretary Root's Plan of Reorganization." Army and Navy Journal,
24 February 1900, p. 595.
- "An Experts Opinion." Army and Navy Journal, 3 March 1900, p. 620,
citing a letter from Major Albrecht, the Boer artillery
commander, to the Deutsche Worte.
- "A New French Cannon." Army and Navy Journal, 17 March 1900, p. 681.
- "British and Boer Artillery." Army and Navy Journal, 31 March 1900,
p. 717.
- "French Guns." Army and Navy Journal, 25 August 1900, p. 1224.
- "Lessons of the Boer War." Army and Navy Journal, 8 September 1900,
p. 42, citing a Sun correspondent with British troops in
South Africa.
- Army and Navy Journal, 22 September 1900, p. 75.
- "A Coast Artillery Corps." Army and Navy Journal, 27 October 1900,
p. 215.

- "The French Field Gun." Army and Navy Journal, 17 November 1900, p. 273.
- "The French Field Gun." Army and Navy Journal, 24 November 1900, p. 301.
- "The French Field Gun." Army and Navy Journal, 24 November 1900, p. 307.
- "What Do the Artillery Want?" Army and Navy Journal, 29 December 1900, p. 418.
- "Foreign Items of Interest." Army and Navy Journal, 12 April 1902, p. 813.
- "Field Artillery Board." Army and Navy Journal, 24 January 1903, p. 494.
- Wilson, C. Holmes. United Service Magazine (English). Cited by Army and Navy Journal, 22 August 1903, p. 1280.
- Millard, Thomas F. Scribner's Magazine, January 1905. Cited in "New Features of War." Army and Navy Journal, 31 December 1904, pp. 460-461.
- "Redoubt Firing at Fort Riley." Army and Navy Journal, 14 September 1907, p. 43.
- "Fort Riley Artillery Experiments." Army and Navy Journal, 28 September 1907, pp. 92-93.
- Benet, Laurence V. "A Study of the Effects of Smokeless Powder in a 57mm Gun." Journal of the United States Artillery 1(January 1892).
- Berry, L. G. "The Artillery of Siege Warfare." Journal of the United States Artillery 2(1893).
- Reilly, Henry J. "Siege Artillery." Journal of the United States Artillery 3(1894).
- Reichold, Moriz Edler von. "Indirect Fire." Translated by J. A. Shipton. Journal of the United States Artillery 8(1897).
- "Howitzers and Mortars for Field Artillery, to Supply a Need of Curved Fire." Journal of the United States Artillery 10(1898).
- Parkhurst, C. D. "The Artillery at Santiago." Journal of the United States Artillery 11(1899).
- "Notes on Rapid-Fire Field Artillery." Translated by W. W. Gibson. Journal of the United States Artillery 16(1901).
- Burr, George W. "The New Field Artillery." Journal of the United States Artillery 19(1903).

Menoher, C. T. "The Panoramic Telescopic Sight." Journal of the United States Artillery 19(1903).

"Present State of Field Artillery Rearmament." Journal of the United States Artillery 21(1904).

Hawthorne, Harry L. "Heavy Caliber Cannon in the Field." Journal of the United States Artillery 29(1908).

Horn, Tiemann N. "Present Method and Lessons in Regard to Field Artillery Taught by the Russo-Japanese War." Journal of the United States Artillery 30(1908).

Joyce, B. P. "New 'Four--Point--Seven' Guns." The Field Artillery Journal 12(1922).

3. Unpublished Material

Hagerman, Edward H. "The Evolution of Trench Warfare in the American Civil War." Ph.D. dissertation Duke University, 1965.

McKenney, Janice E. "Field Artillery." Draft manuscript for the Army Lineage Series, U.S. Army Center of Military History, Washington, D.C., 1972.