

UNCLASSIFIED

AD NUMBER

ADB027191

LIMITATION CHANGES

TO:

Approved for public release; distribution is unlimited.

FROM:

Distribution authorized to U.S. Gov't. agencies only; Test and Evaluation; APR 1977. Other requests shall be referred to Air Force Armament Lab., Eglin AFB, FL 32542.

AUTHORITY

USADTC ltr 10 Apr 1980

THIS PAGE IS UNCLASSIFIED

THIS REPORT HAS BEEN DELIMITED
AND CLEARED FOR PUBLIC RELEASE
UNDER DOD DIRECTIVE 5200.20 AND
NO RESTRICTIONS ARE IMPOSED UPON
ITS USE AND DISCLOSURE.

DISTRIBUTION STATEMENT A

APPROVED FOR PUBLIC RELEASE;
DISTRIBUTION UNLIMITED.

AFATL-TR-77-50

✓ FOR FURTHER TRAN

(2)



A ROCKET ENGINE EXHAUST PLUME TEMPERATURE PROFILE BY LINE REVERSAL TECHNIQUE

AIR-TO-AIR MISSILES BRANCH
GUIDED WEAPONS DIVISION

APRIL 1977

FINAL REPORT FOR PERIOD
JULY 1976-NOVEMBER 1976

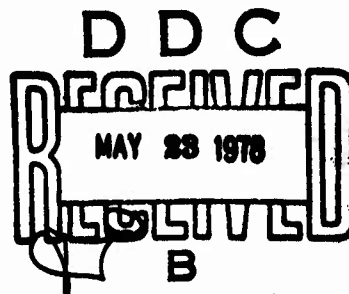

Distribution limited to U. S. Government agencies only; this report documents test and evaluation; distribution limitation applied April 1977 . Other requests for this document must be referred to the Air Force Armament Laboratory (DLMI), Eglin Air Force Base, Florida 32542.

AU INU.
DDC FILE COPY

AD B 0 2 7 1 9 1

AIR FORCE ARMAMENT LABORATORY

AIR FORCE SYSTEMS COMMAND • UNITED STATES AIR FORCE

EGLIN AIR FORCE BASE, FLORIDA



REPORT DOCUMENTATION PAGE		READ INSTRUCTIONS BEFORE COMPLETING FORM	
1. REPORT NUMBER	2. GOVT ACCESSION NO.	3. RECIPIENT'S CATALOG NUMBER	
14 AFATL-TR-77-51			
4. TITLE (and Subtitle)		5. TYPE OF REPORT & PERIOD COVERED	
6. A ROCKET ENGINE EXHAUST PLUME TEMPERATURE PROFILE BY LINE REVERSAL TECHNIQUE		Final Report July - Nov 1976	
7. AUTHOR(s)		6. PERFORMING ORG. REPORT NUMBER	
10 Jeffrey W. Griffin, Richard T. Schneider William J. Rothschild		8. CONTRACT OR GRANT NUMBER(s)	
9. PERFORMING ORGANIZATION NAME AND ADDRESS		10. PROGRAM ELEMENT PROJECT, TASK AREA & WORK UNIT NUMBERS	
Air-to-Air Missiles Branch Guided Weapons Division Air Force Armament Laboratory Eglin Air Force Base, Florida 32542		Program Element: 62602F JON: 1921-03 01	
11. CONTROLLING OFFICE NAME AND ADDRESS		12. REPORT DATE	
Air Force Armament Laboratory Armament Development and Test Center Eglin Air Force Base, Florida 32542		11 Apr 1977	
14. MONITORING AGENCY NAME & ADDRESS (if different from Controlling Office)		13. NUMBER OF PAGES	
12 76p		77	
		15. SECURITY CLASS. (of this report)	
		UNCLASSIFIED	
		15a. DECLASSIFICATION DOWNGRADING SCHEDULE	
16. DISTRIBUTION STATEMENT (of this Report)			
Distribution limited to U.S. Government agencies only; this report documents test and evaluation; distribution limitation applied April 1977. Other requests for this document must be referred to the Air Force Armament Laboratory (DLMI) Eglin Air Force Base, Florida 32542.			
17. DISTRIBUTION STATEMENT (of the abstract entered in Block 20, if different from Report)			
18. SUPPLEMENTARY NOTES			
Available in DDC			
19. KEY WORDS (Continue on reverse side if necessary and identify by block number)			
Hydrocarbon Exhaust Plume Characteristics Air-to-Air Missiles and Target Systems IR Signature Optical Measurement of Plume Properties Temperature Maps of Exhaust Plumes			
20. ABSTRACT (Continue on reverse side if necessary and identify by block number)			
This report contains temperature profile measurements of a small rocket engine burning RP-1 fuel. A standard line reversal technique with sodium as the emitting species was utilized. Apparent temperature maps of the engine plumes produced by oxygen-rich and fuel-rich mixture ratios in a stratochamber simulating altitude (pressure) conditions are also represented.			

→ Apparatus used for the measurements and calibration procedure
are fully described in the report. ↖

PREFACE

The work reported herein was conducted by the Air Force Armament Laboratory (AFATL) at Eglin Air Force Base, Florida, under Program Element 62602F, Project Number 19210301 as a part of the Infrared Technology Program. The work was performed in-house by the Infrared Technology Team of the Air to Air Missiles Branch during the period July 1976 to November 1976. By agreement between the AFATL and the University of West Florida, the data acquired and the experimental technique are also the subject of a masters' thesis for Mr. Jeffrey W. Griffin.

The authors wish to acknowledge the valuable assistance of Mr. Dale E. Fink and SSgt. Daniel Santo (DLMI).

This technical report has been reviewed and is approved for publication.

FOR THE COMMANDER

CLIFFORD H. ALLEN, JR., Colonel, USAF
Chief, Guided Weapons Division

ACCESSION for		
NTIS	Life Section	<input type="checkbox"/>
DDC	Gift Section	<input checked="" type="checkbox"/>
UNANNOUNCED		<input type="checkbox"/>
JUSTIFICATION		
BY _____		
DISTRIBUTION/AVAILABILITY CODES		
Dist.	AVAIL	SPECIAL
B		

TABLE OF CONTENTS

Section	Title	Page
I.	INTRODUCTION	1
II.	THE MEASUREMENT METHOD	3
	1. Line Reversal Technique	3
	2. Temperature Unfolding Technique	6
	3. Determination of Concentration	9
III.	EXPERIMENTAL SET-UP	11
	1. Rocket Engine	11
	2. Optical Arrangement	12
IV.	EXPERIMENTAL RESULTS	15
	1. Temperature Measurements	15
	2. Relative Concentrations	16
References	39
Appendixes		
A	Determination of Species Concentration	41
B	Plume Temperature Unfolding Technique	44
C	Radial Temperature Scans	57

LIST OF FIGURES

Figure	Title	Page
1	Line Reversal Technique	18
2	Cross Section of Rocket Produced Plasma Field	19
3	Three Ring Division System	20
4	Ray Path Through Two Rings	21
5	Ray Path Through Three Rings	22
6	Imaging System	23
7	Oscilloscope Display for Sodium Doublet	24
8	Oscilloscope Displays for Pre- and Post-Reversal	25
9	Sample Data Set	26
10	Tungsten Lamp Calibration Curve	27
11	Filament Image Calibration Curve	28
12	Exhaust Plume	29
13	Centerline Temperature Distribution (O/F = 4.5)	30
14	Centerline Temperature Distribution (O/F = 4.5)	31
15	Radial Temperature Distribution (O/F = 4.5)	32
16	Unfolded Plume Temperature Distribution	33
17	Temperature Map of Plume	34
18	Relative OH Concentration Versus O/F Ratio	35
19	Relative CH Concentration Versus O/F Ratio	36
20	Relative C ₂ Concentration O/F Ratio	37
21	Infrared Radiant Intensity Versus O/F Ratio	38

SECTION I

INTRODUCTION

The investigation of hydrocarbon exhaust plume characteristics is of interest to the Air Force for air-to-air missiles and target systems. IR seeker response during terminal guidance is at least partially determined by the spatial distribution of plume radiation.

The optical and IR signature of the plume is determined by the temperature distribution and the characteristic frequencies (spectrum lines) of the radiating species. The radiating species are the combustion products and radicals formed by the chemical reactions in the rocket plume. For this reason, experimental determination of these properties is of utmost importance. In addition, reliable analytical models of hydrocarbon rocket or jet engine plumes need to be developed to predict the behavior of new or unknown engine designs.

Optical measurement of plume properties (temperature and intensities) is mandatory for the validation of these models. Another way to check these models is to measure the concentration of the combustion products and radicals formed in the rocket plume and the relative changes in concentration of these species if the oxygen to fuel (O/F) ratio is changed. This information can also be obtained by spectroscopic measurements. Consequently, the primary objective of this project was to produce temperature maps of the exhaust plume generated by a small rocket engine burning RP1 with gaseous O_2 as the oxidizer. After having obtained the temperature distributions, previous measurements of spectral intensities of radicals could be converted into relative changes in concentration as a function of oxygen to fuel ratio. The method chosen for the temperature measurements was the line reversal technique with sodium used as the emitting species. The temperatures obtained with such a technique are most accurate when obtained from a homogeneous plasma of constant temperature, density, and species concentration. When such conditions are not met (such as in rocket exhaust plumes) the measurements produce an average temperature due to the existence of temperature gradients. Techniques are proposed for unfolding these average temperature profiles to produce corrected radial temperature distributions of the plume. The investigations reported here are the first experimental application of these techniques to a rocket plume.

Average temperature maps were made of plumes produced by both oxygen-rich (O/F = 4.5) and fuel-rich (O/F = 2) mixture ratios. For the oxygen-rich conditions (O/F = 4.5) both radial centerline temperature measurements were made.

A corrected (unfolded) radial temperature distribution was generated for one plume cross section at the O/F = 4.5 condition. The unfolded temperature profile was compared with the average temperature profile obtained at the same location. This procedure provides an estimate of the error incurred in applying standard line reversal techniques to non-homogeneous rocket plumes.

Due to unstable burning conditions and poor plume definition at the fuel-rich mixture ratio ($O/F = 2$) only a centerline temperature distribution was produced. However, the experience gained with unfolding of the $O/F = 4.5$ temperature profile makes it possible to estimate the true temperature of these measurements even without undergoing an unfolding procedure.

SECTION II

THE MEASUREMENT METHOD

1. LINE REVERSAL TECHNIQUE

For a homogeneous plasma in thermodynamic equilibrium, the radiation field is given by

$$I_{\lambda} = B_{\lambda}^P(T) = \frac{2hc_0^2}{\lambda^5} \frac{1}{\exp(hc_0/\lambda kT) - 1} \quad (1)$$

where $B_{\lambda}^P(T)$ is the Planck function and T is the plasma temperature.

In case of complete thermodynamic equilibrium, the plasma is a blackbody and its radiation is only a function of surface area and temperature. It is not a function of any material constants. A rocket plume is not such a radiator, it is only local in thermodynamic equilibrium (LTE). In this case, the radiation is determined by the volume of the plasma, its temperature and a materials constant, usually expressed as an absorption coefficient. Consider a homogeneous slab of plasma in local thermodynamic equilibrium (LTE) as indicated in Figure 1. At any given point inside this plasma the radiation field is determined by two competing factors. The plasma emits energy of amount ϵ_{λ} erg/cm³ sec per unit wavelength, where ϵ_{λ} is the emission coefficient. It also absorbs energy at the rate $k(\lambda)I_{\lambda}(r)$ where $k(\lambda)$ is the absorption coefficient of the plasma at a particular wavelength and $I_{\lambda}(r)$ is the radiation intensity of some position r in the plasma slab. The rate of change of intensity through the slab is a function of these two competing terms and is, obviously, given by their difference

$$\frac{dI_{\lambda}(r)}{dr} = \epsilon_{\lambda} - k(\lambda)I_{\lambda}(r) \quad (2)$$

It is assumed that the plasma slab under consideration is homogeneous, which means that temperature, emission coefficient and absorption coefficient are not a function of r . Of course, this is only an initial assumption for discussion of the method. In a real plasma, like a rocket plume, these properties are indeed a function of r . In this case, it will be necessary to divide the plume into rings small enough that it can be assumed that within one ring the plasma is homogeneous.

The assumption of LTE requires that Kirchoff's Law is valid. Kirchoff's Law establishes a connection between ϵ_{λ} and $k(\lambda)$. It states that the ratio of emission coefficient to the absorption coefficient is only a function of temperature and is equal to the Planck function. The result being that

$$\epsilon_{\lambda} = k(\lambda) B_{\lambda}^P(T). \quad [B_{\lambda}^P(T) \text{ Planck function of the plasma}] \quad (3)$$

Inserting this result into equation (2) yields

$$\frac{dI_{\lambda}(r)}{dr} = k(\lambda) B_{\lambda}^P(T) - k(\lambda) I_{\lambda}(r) \quad (4)$$

or

$$\frac{dI_{\lambda}(r)}{dr} = k(\lambda) [B_{\lambda}^P(T) - I_{\lambda}(r)] \quad (5)$$

This may be integrated utilizing a change of variable

$$B_{\lambda}^P(T) - I_{\lambda}(r) = K \quad (6)$$

or

$$I_{\lambda}(r) = B_{\lambda}^P(T) - K \quad (7)$$

and

$$dI_{\lambda}(r) = -dK \quad (8)$$

Inserting equation (6) and equation (8) into equation (5) we have

$$- \frac{dK}{dr} = k(\lambda) K \quad (9)$$

or

$$\frac{dK}{K} = -k(\lambda) dr \quad (10)$$

Integration of equation (10) produces

$$\int_{K_0}^K \frac{dK}{K} = -k(\lambda) \int_0^r dr \quad (11)$$

or

$$\ln K = -k(\lambda)r + \ln K_0 \quad (12)$$

and

$$K = C e^{-k(\lambda)r} \quad (13)$$

where

$$K_0 = C \quad (14)$$

Utilizing equation (6) yields

$$I_{\lambda}(r) = B_{\lambda}^P(T) - C e^{-k(\lambda)r} \quad (15)$$

Letting $I_{\lambda}(r) = I_{\lambda,0}$ at $r = 0$, C may be evaluated

$$C = B_{\lambda}^P(T) - I_{\lambda,0} \quad (16)$$

Finally, inserting equation (16) into equation (15) yields

$$I_{\lambda}(r) = B_{\lambda}^P(T) - [B_{\lambda}^P(T) - I_{\lambda,0}] e^{-k(\lambda)r} \quad (17)$$

or

$$I_{\lambda}(r) = B_{\lambda}^P(T) [1 - e^{-k(\lambda)r}] + I_{\lambda,0} e^{-k(\lambda)r} \quad (18)$$

In the technique of line reversal temperature measurement a standard illumination source is imaged upon the boundary of the plasma field. The image of the source is calibrated against a standard blackbody, thereby giving an equivalent brightness temperature for the illuminating radiation $I_{\lambda,0}$ in Figure 1. The incident radiation intensity can thereby be given as

$$I_{\lambda,0} = B_{\lambda}^S(T) \quad (19)$$

where $B_{\lambda}^S(T)$ is the Planck function for the source image. The temperature of the standard source is adjusted until the output intensity equals the incident intensity or

$$I_{\lambda}(r) = B_{\lambda}^P(T) [1 - e^{-k(\lambda)r}] + B_{\lambda}^S(T) e^{-k(\lambda)r} = B_{\lambda}^S(T) \quad (20)$$

for $r = \ell$ we have

$$B_{\lambda}^S(T) = B_{\lambda}^P(T) [1 - e^{-k(\lambda)\ell}] + B_{\lambda}^S(T) e^{-k(\lambda)\ell} \quad (21)$$

the final result being that

$$B_{\lambda}^S(T) = B_{\lambda}^P(T) \quad (22)$$

Since the Planck function is a function only of temperature, this implies that the plasma and source image temperature are equal

$$T_P = T_S \quad (23)$$

The above technique is correct only for homogeneous slabs in local thermodynamic equilibrium. In other words, the states of atoms or molecules emitting the wavelength region which is used for the line reversal technique have to be excited according to a Maxwell-Boltzmann distribution. For a good precision of the measurement it is also required that the absorption coefficient is of a certain minimum value. Although the absorption coefficient is not explicitly measured, the method depends on the fact that absorption takes place in the plasma [see Equation (2)].

Absorption requires that the lower state of the spectrum line used for the method is appreciably populated. This can be guaranteed best by using as the lower state the ground state of the atom. For this reason mostly resonance lines are used for the line reversal method. Only a few chemical elements have resonance lines in the visible spectrum region (e.g., Na, K,).

2. TEMPERATURE UNFOLDING PROCEDURE

Temperatures are not additive. Therefore, if a temperature gradient exists, regular Abel unfolding techniques which are based on the fact that intensities are additive cannot be used.

However, the quantity $t = k \cdot \ell$, sometimes referred to as an optical length, is additive. A temperature unfolding technique can be based on this fact.

Therefore, a radial temperature distribution may be obtained by dividing the plume cross section into thin concentric homogeneous rings. Figure 2 illustrates such a division where a three-ring section is utilized. Each ring is assumed to contain a homogeneous plasma with Planck function $B_{\lambda}^{Pn}(T)$ and absorption coefficient $k_n(\lambda)$. This assumption requires the existence of LTE with Kirchoff's Law being valid in a narrow spectral range. The accuracy of such a layering technique is, of course, dependent upon the thickness of the slabs, therefore Δ is kept small.

The calculation of the $B_{\lambda}^{Pn}(T)$ is straightforward, provided the outermost ring temperature is known. This temperature may be obtained by a line reversal temperature measurement. The method of determining the remaining $B_{\lambda}^{Pn}(T)$ is now explained.

For simplicity, consider a plasma divided into three rings as seen in Figure 3. Consider incident radiation of intensity $I_{\lambda,0n}$. The total intensity on the right side of the plasma is I_{Tn} . Let I_{Pn} be the intensity of radiation emitted by the plasma itself. Then

$$I_{Tn} = I_{Pn} + I_{\lambda,0n} e^{-\tau_n} \quad (24)$$

where τ_n is the optical thickness of the plasma for a given path and is given byⁿ

$$\tau_n = 2 \sum_{m=1}^n k_m(\lambda) \ell_{n,m} \quad (25)$$

For the outermost ray (outside ring only traversed) we have that

$$I_{T1} = I_{P1} + I_{\lambda,0} e^{-\tau_1} \quad (26)$$

where

$$\tau_1 = 2k_1(\lambda)l_{1,1} \quad (27)$$

or

$$k_1(\lambda) = \frac{1}{2l_{1,1}} \ln \left[\frac{I_{\lambda, O_1}}{I_{T_1} - I_{P_1}} \right] \quad (28)$$

The intensities in equation (28) are easily determined and $l_{1,1}$ is measurable from the plume geometry. Knowing $k_1(\lambda)$ the remaining $k_n(\lambda)$ may be determined.

$$k_2(\lambda) = \frac{1}{2l_{2,2}} \ln \left[\frac{I_{\lambda, O_2}}{I_{T_2} - I_{P_2}} \right] - \frac{k_1(\lambda)l_{2,1}}{l_{2,2}} \quad (29)$$

where

$$\tau_2 = 2[k_2(\lambda)l_{2,2} + k_1(\lambda)l_{2,1}] \quad (30)$$

and

$$k_3(\lambda) = \frac{1}{2l_{3,3}} \ln \left[\frac{I_{\lambda, O_3}}{I_{T_3} - I_{P_3}} \right] - \left[\frac{l_{3,1}k_1(\lambda) + l_{3,2}k_2(\lambda)}{l_{3,3}} \right] \quad (31)$$

where

$$\tau_3 = 2[l_{3,1}k_1(\lambda) + l_{3,2}k_2(\lambda) + l_{3,3}k_3(\lambda)] \quad (32)$$

The problem now remains to calculate the $B_{\lambda}^{Pn}(\tau)$. As stated earlier, the temperature and thereby the Planck function of the outer ring are determined through line reversal measurements. Therefore $B_{\lambda}^{P1}(\tau)$ is known.

Consider now the ray that passes through the outer two rings (Figure 4).

Inside the first ring the intensity may be written as

$$I(r_1) = B_{\lambda}^{P1}(\tau) [1 - e^{-k_1(\lambda)r_1}] + I_{\lambda, O_2} e^{-k_1(\lambda)r_1} = A \text{ for } r_1 = l_{2,1} \quad (33)$$

Inside the second ring we have

$$I(r_2) = B_{\lambda}^{P2}(\tau) [1 - e^{-k_2(\lambda)r_2}] + A e^{-k_2(\lambda)r_2} = B \text{ for } r_2 = 2l_{2,2} \quad (34)$$

On the far side again in the first ring we have

$$I(r_3) = B_{\lambda}^{P1}(T) [1 - e^{-k_1(\lambda)r_3}] + B_{\lambda} e^{-k_1(\lambda)r_3} \quad (35)$$

At reversal for $r_3 = l_{2,1}$ we have

$$I(r_3) = I_{\lambda, O_2} = B_{\lambda}^{S2}(T) \quad (36)$$

where $B_{\lambda}^{S2}(T)$ is the Planck function for the source image. Since the objective of this technique is to improve upon line reversal temperature measurements the $B_{\lambda}^{Sn}(T)$ are known from previously generated average temperature profiles. So we have that

$$\begin{aligned} B_{\lambda}^{S2}(T) = & B_{\lambda}^{P1}(T) [1 - e^{-k_1(\lambda)l_{2,1}}] \\ & + \left[B_{\lambda}^{P2}(T) \{1 - e^{-2k_2(\lambda)l_{2,2}}\} \right. \\ & + \{B_{\lambda}^{P1}(T) [1 - e^{-k_1(\lambda)l_{2,1}}] \\ & \left. + B_{\lambda}^{S2}(T) e^{-k_1(\lambda)l_{2,1}} e^{-2k_2(\lambda)l_{2,2}} \right] e^{-k_1(\lambda)l_{2,1}} \quad (37) \end{aligned}$$

This may be solved for $B_{\lambda}^{P2}(T)$ and we have

$$\begin{aligned} B_{\lambda}^{P2}(T) = & \left[\frac{B_{\lambda}^{S2}(T) - B_{\lambda}^{P1}(T) [1 - e^{-k_1(\lambda)l_{2,1}}]}{e^{-k_2(\lambda)l_{2,1}}} \right] \\ & - \frac{\{B_{\lambda}^{P1}(T) [1 - e^{-k_1(\lambda)l_{2,1}}] + B_{\lambda}^{S2}(T) e^{-k_1(\lambda)l_{2,1}} e^{-2k_2(\lambda)l_{2,2}}\}}{[1 - e^{-2k_2(\lambda)l_{2,2}}]} \quad (38) \end{aligned}$$

Since the Planck function is a function of temperature only, the temperature of the second ring is determined. The process is cascading one, i.e., each consecutive ring temperature requires all of the outer ring temperatures. For the path through three rings we have (Figure 5)

$$I(r_1) = B_{\lambda}^{P1}(T) [1 - e^{-k_1(\lambda)r_1}] + I_{\lambda, O_3} e^{-k_1(\lambda)r_1} = A \text{ for } r_1 = l_{3,1} \quad (39)$$

$$I(r_2) = B_{\lambda}^{P2}(T) [1 - e^{-k_2(\lambda)r_2}] + A e^{-k_2(\lambda)r_2} = B \text{ for } r_2 = l_{3,2} \quad (40)$$

$$I(r_3) = B_{\lambda}^{P3}(T) [1 - e^{-k_3(\lambda)r_3}] + B e^{-k_3(\lambda)r_3} = C \text{ for } r_3 = 2l_{3,3} \quad (41)$$

$$I(r_4) = B_{\lambda}^{P2}(T) [1 - e^{-k_2(\lambda)r_4}] + C e^{-k_2(\lambda)r_4} = D \text{ for } r_4 = l_{3,2} \quad (42)$$

and finally

$$I(r_5) = B_{\lambda}^{P1}(T) [1 - e^{-k_1(\lambda)r_5}] + D e^{-k_1(\lambda)r_5} = E \text{ for } r_5 = l_{3,1} \quad (43)$$

For the reversal condition we have

$$E = B_{\lambda}^{S3}(T) \quad (44)$$

and

$$B_{\lambda}^{P1}(T) [1 - e^{-k_1(\lambda)l_{3,1}}] + D e^{-k_1(\lambda)l_{3,1}} = B_{\lambda}^{S3}(T) \quad (45)$$

This equation contains one unknown, namely $B_{\lambda}^{P3}(T)$. Thus it can be seen that the ring temperatures can be determined by the above procedure. The technique can be extended to any number of rings desired.

3. DETERMINATION OF CONCENTRATIONS

As pointed out in the introduction the measurement of concentrations of radiating species provides insight into the chemistry of the rocket plume. In case of atomic species, if a Maxwell-Boltzmann distribution of states exists, the intensity density of an emission line of a spectrum line can be related to the particle density n_0 (and so to the concentration) by:

$$I = n_0 \frac{g}{U} h\nu A e^{-\frac{E}{KT}} \quad (46)$$

where

g = statistical weight or degeneracy of the upper state of the line

A = transition probability

$h\nu$ = energy of the photon

U = partition function

E = excitation energy of the line

K = Boltzmann factor

T = temperature.

If the temperature is known, measurement of the intensity will produce a value for n_0 , since all the other quantities in equation (46) are known atomic constants. Measurement of relative change of intensity for a changing O/F ratio in the rocket plume can be interpreted in terms of the relative change in concentration of a certain species, again under the assumption that the temperature has been measured by some means (e.g., the line reversal method). The complete technique is described in Appendix A.

Most of the radiating species in the rocket plume are, however, molecules or radicals. In this case a modified form of equation (46) which gives the intensity of a line in a rotational band must be used.

$$I \propto (2J + 1) e^{-\frac{J(J+L)h}{8\pi^2 \Theta KT}} \quad (47)$$

where

J = rotational Quantum number

$\Theta = mr^2$ (m = mass of molecule

r = intermolecular separation distance)

h = Planck's Constant

SECTION III EXPERIMENTAL SET-UP

1. ROCKET ENGINE

The experiment described in this report was conducted at the Range 22 Stratochamber Test Facility at Eglin Air Force Base. The capabilities of this installation are described in Reference 1. The experimental apparatus consisted of a small kerosene/gaseous oxygen rocket which exhausted into a vacuum chamber, a sodium injection system, a standard illumination source, an imaging optical system, and a spectroscopic measurement system.

The rocket engine used in the experiment was a small kerosene/gaseous oxygen rocket that is based on an original design by Astrosystems, Inc., Lake Success, New York. The rocket engine injector essentially consists of a cylinder with a 0.055-inch-diameter orifice. Gaseous oxygen is introduced into the injector upstream of the kerosene and at a higher pressure than the kerosene. This design permits mixing and atomization to occur prior to injection into the combustion chamber. In the wall of the combustion chamber is a port for injection of seed material (sodium chloride) into the plume for application of the line reversal technique. Typical chamber pressure is 40 psi requiring that the seed supply line be pressurized at a higher value (80 to 100 psi).

The engine was mounted on a horizontal/vertical translator which was electronically controlled outside of the chamber during data runs. The translator was capable of engine movements of 1 mm increments along both axes. Associated with the rocket engine was the control panel and flow hardware. Precision micrometer valves located in the respective lines permitted the fuel and oxygen flow rates to be adjusted to achieve a desired oxygen to fuel ratio during operation of the engine. The combustible mixture is initially ignited by a spark plug. Total mass flow for the engine was maintained at 5 grams per second. For the O/F = 2

condition, the flow rates were oxygen 3.33 grams per second, RPI 1.67 grams per second and for O/F = 4.5, oxygen 4.10 grams per second, RPI 90 grams per second.

A sodium chloride/water solution of 47 grams per liter was used as the plume seed material. The solution was force-fed to the engine through a 0.25 inch copper line from a nitrogen pressurized steel tank. Tank pressure ranged from 80 to 100 psi. Metering was accomplished by a precision micrometer needle valve. To facilitate metering, a 0.018-inch-diameter orifice was placed ahead of the combustion chamber port. The orifice also acted as an atomizer for the sodium chloride solution and prevented extinction of the plume by excess water. Consistent sodium chloride injection was insured by constant monitoring of combustion chamber pressure and maintenance of this pressure at approximately 40 psi.

2. OPTICAL ARRANGEMENT

The objectives of the optical imaging system were to (1) image a tungsten ribbon lamp filament upon the rocket plume centerline with a magnification ratio equal to unity, and (2) image the plume and filament upon the entrance slit of the spectrometer with a convenient magnification ratio. A schematic diagram of the imaging system is shown in Figure 6.

The tungsten filament was imaged by a telephoto astigmat lens with an effective focal length of 20 inches and f-number of 5.6. Unity magnification required that the filament be located a distance of $(2) \times$ (effective focal length) from the principal plane of the lens. Verification of correct distances is accomplished by accurately measuring the filament size and adjusting the optics to obtain unity magnification.

The filament image and plume were imaged onto the spectrometer entrance slit by a 12-inch-diameter parabolic mirror of focal length 2.51 meters. This is facilitated by folding the beam with a 12-inch-diameter plane front surface mirror. The plume and filament image are slightly magnified by this system with a magnification ratio of 1.05. The spectrometer used was a 0.75 meter Czerny-Turner mount (manufacturer: Jarrell-Ash).

The spectrometer was equipped with a 148-groove/mm grating blazed for 5 microns.

A 500-element silicon multichannel detector unit was mounted at the exit plane of the spectrometer and the grating rotated to allow illumination of the detector array by the sodium doublet (approximately 5890Å). The multichannel detector unit was interfaced with an Optical Multichannel Analyzer (OMA). The OMA (manufacturer: Princeton Applied Research) allowed real time display of relative incident intensities upon the silicon detector array via oscilloscope interfacing, as indicated in Figure 7.

Such relative intensity displays could be stored in the OMA memory unit and plotted for permanent record with an X-Y plotter.

Figure 8 shows a typical output of the X-Y plotter for pre-reversal and post-reversal conditions. Figure 9 shows how actual reversal was established. Once a reversal condition was established (center part of Figure 9) the lamp temperature was increased slightly (upper part of Figure 9) and decreased slightly (lower part of Figure 9) until a distinct signal could be detected. In the case of Figure 9, this required an increase or decrease of the shunt voltage drop by 0.04 mV. This translates into change in temperature of $\pm 6^{\circ}\text{K}$. The sensitivity of the method, which is the relative error, is therefore better than this value.

The standard light source consisted of a calibrated tungsten ribbon lamp with its associated variable high current dc power supply. A precision shunt was inserted in series with the lamp filament and the voltage drop across the shunt was monitored by a dc micro-voltmeter. This allowed calibration of the lamp with an optical pyrometer, the result being establishment of a relationship between shunt voltage and filament brightness temperature. The calibration curve is shown in Figure 10.

As pointed out above, in the line reversal technique the tungsten ribbon lamp filament is imaged onto the boundary of the plasma field produced by the rocket plume. The filament image thereby becomes the new standard source for experimental measurements. This necessitates calibration of the filament image with an optical pyrometer.

The resultant calibration curve which relates the shunt voltage of the filament of the standard lamp to the brightness temperature of the filament image at the centerline of the plume is shown in Figure 11. This calibration curve is slightly different from Figure 10, due to the fact that the standard lamp radiation experiences a slight absorption at window No. 1 when entering the vacuum chamber. Of course, there is also some absorption in window No. 2. But, since both the light coming from the standard lamp and light coming from the plume are absorbed in the same way, the influence of window No. 2 cancels and the temperature measurement is not affected.

SECTION IV

EXPERIMENTAL RESULTS

1. TEMPERATURE MEASUREMENTS

A photograph of the exhaust plume is shown in Figure 12. There is a visible shock structure which corresponds quite well to the structure observed in the temperature scans.

These results are shown in Figures 13 and 14. The spatial resolution of the measurement setup was 1 mm. Figure 13 is a plot of the centerline temperature of the plume for an O/F = 4.5, which is a lean mixture. The nozzle exit temperature was found to be $T_{ex} = 2503^{\circ}\text{K}$, which compares very well with the theoretical prediction of $T_{ex} = 2570^{\circ}\text{K}$ reported by Vamos (Reference 2). The temperature rises in the front of each shock drastically (from 1825°K to 2245°K within 1 mm at the first shock front) and decreases to a temperature of $T = 1827^{\circ}\text{K}$ which is fairly uniform between all shocks. Figure 14 shows the same measurement for an O/F = 2.0 (rich mixture). The temperatures are, in general, lower and the temperature rise in the shock front is not nearly as pronounced as in the O/F = 4.5 case. These findings have to be compared to Figures 18, 19, and 20, which indicate increased formation of radicals with increasing richness of the fuel mixture. This means formation and excitation of the radicals at the expense of random energy of the plume proper.

The line reversal measurements indicate that the plume exhibits a moderate temperature gradient in the radial direction. A reversal temperature profile for one cross section at the O/F = 4.5 condition is shown in Figure 15. This profile was unfolded to produce a true radial temperature distribution which is shown in Figure 16. A full discussion of the unfolding technique including actual data and a computer program for numerical evaluation of the data are contained in Appendix B. A large number of cross sections were scanned and this material is compiled in Appendix C. From this material a temperature map of the plume was

constructed for the case of $O/F = 4.5$. This map is shown in Figure 17. Since the radial temperature gradients were moderate, the correction obtained by the unfolding process was less than 30 percent. However, the precision of the line reversal technique for the temperature range of interest for this investigation is ± 1 percent. Therefore, the corrections resulting from this unfolding process seem very worthwhile.

2. RELATIVE CONCENTRATIONS

The visible and ultraviolet spectra were obtained in the rocket plume previously (Reference 3). The observed spectra were those of the radicals OH, CH, and C_2 (Swan and higher pressure bandhead at 5165\AA). The relative intensity of these bands was measured as a function of oxygen to fuel mixture ratio. In all cases, an extremely sharp increase in band intensity occurs when the mixture ratio is reduced below $O/F = 3.5$ (stoichiometric) and reaching a maximum at $O/F = 1.8$. The same behavior is found for the total CO_2 in the 4- to 5-micrometer infrared emission band. These data show that the plume radiation is primarily due to external combustion between fuel-rich exhaust products and air.

The obtained relative intensities were converted into relative concentrations using the reported temperatures. Details of the conversion technique are contained in Appendix A. The results based on the above three bandhead wavelengths are shown in Figures 18, 19 and 20. In all cases, an extremely sharp increase in band radiation intensity occurs as the O/F ratio is reduced below 3.5 (stoichiometry). This variation with O/F ratio is similar to that observed in molecular CO_2 emission in the infrared band between 4 and 5 microns, although the rate of increase in visible band radiation is much larger. The previously measured (Reference 3) infrared radiant intensity variation with mixture ratio is reproduced in Figure 21 to show the comparison.

The presence of strong C_2 and CH emission are indicators of fuel-rich flame combustion. Their concentrations begin to fall off below a mixture ratio of 1.8, as does the infrared radiant intensity, indication that the threshold for carbon luminosity may have been reached. However, although

carbon soot is visually evident in the exhaust of engines under these fuel-rich conditions, it is apparent that the amount is nonetheless not high enough to contribute significant infrared radiation.

The data thus show the rocket engine radiation to be primarily due to external combustion. An increase in infrared radiation accompanies the increase in visible radiation, i.e., the increase in external combustion. No graybody radiation is present in the infrared spectrum under these conditions (Reference 3) and only a limited visible continuum was observed over the shock regions.

OH radical was determined to be the major plume emitter at visible and ultraviolet wavelengths at high mixture ratios and beyond the region of the shocks. None of the major molecular combustion products, such as H_2O , CO_2 , or CO , some of which are primary infrared radiators, were observed to emit in the visible or ultraviolet. The O/F ratio, as in the infrared wavelengths, is the predominant parameter affecting the intensity and spectrum of OH radiation in the UV.

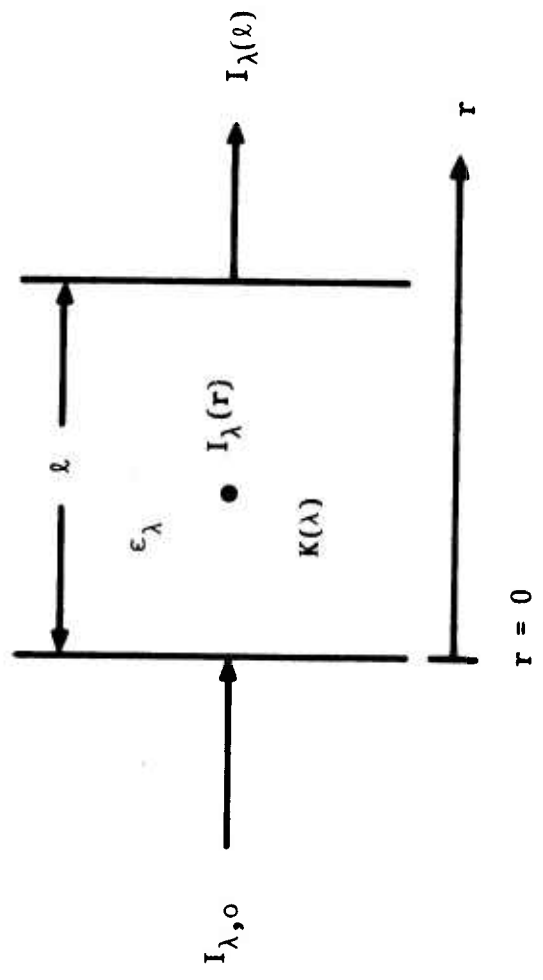

Figure 1. Line Reversal Technique

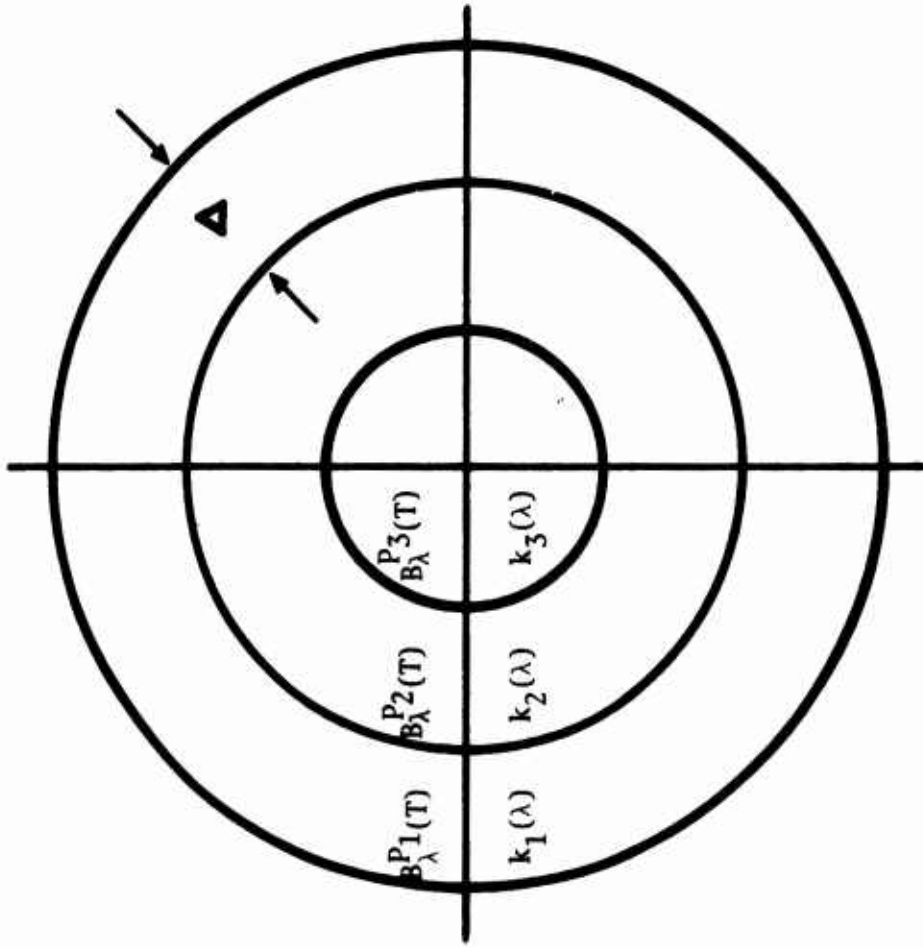

Figure 2. Cross Section of Rocket Produced Plasma Field

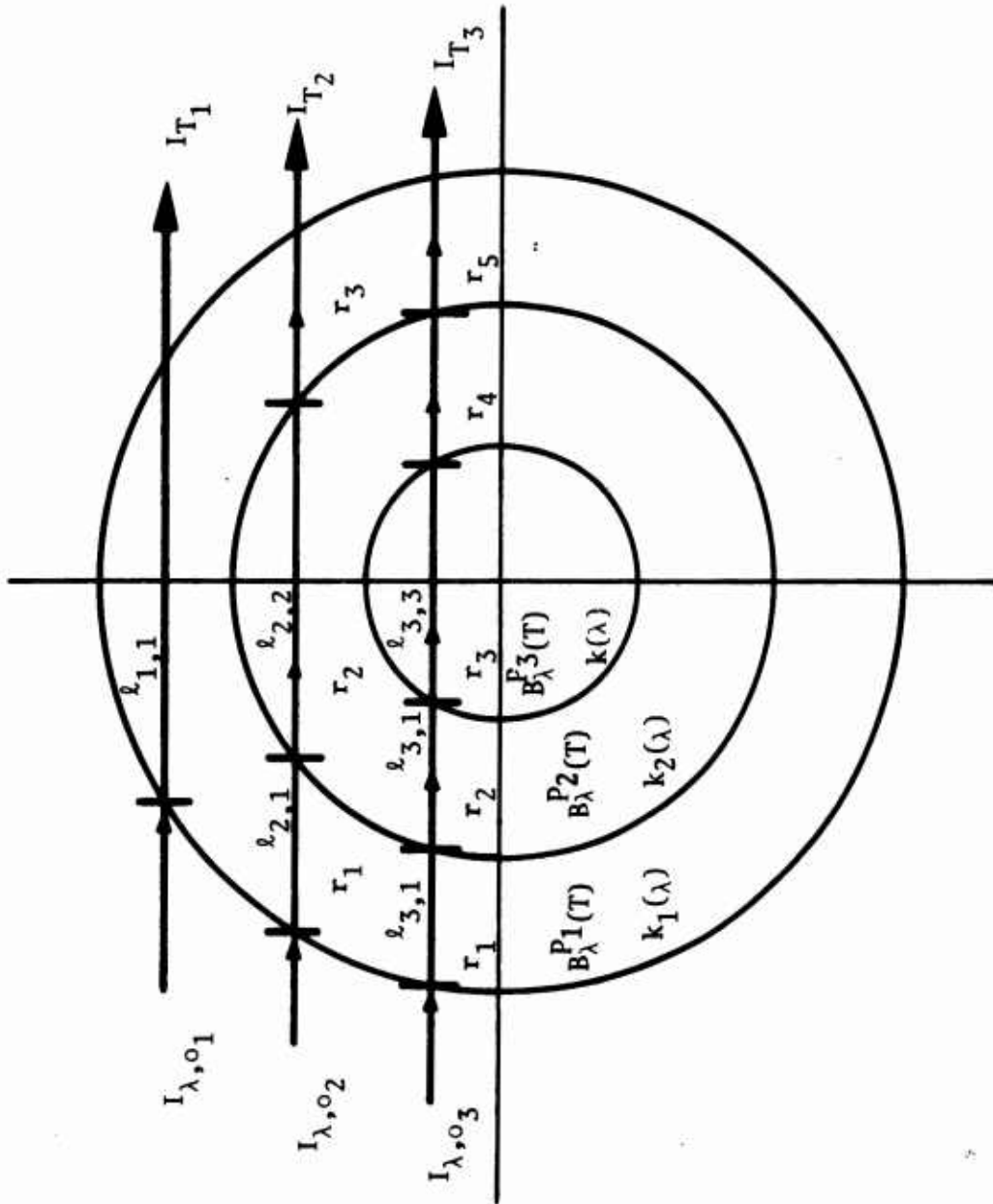

Figure 3. Three Ring Division System

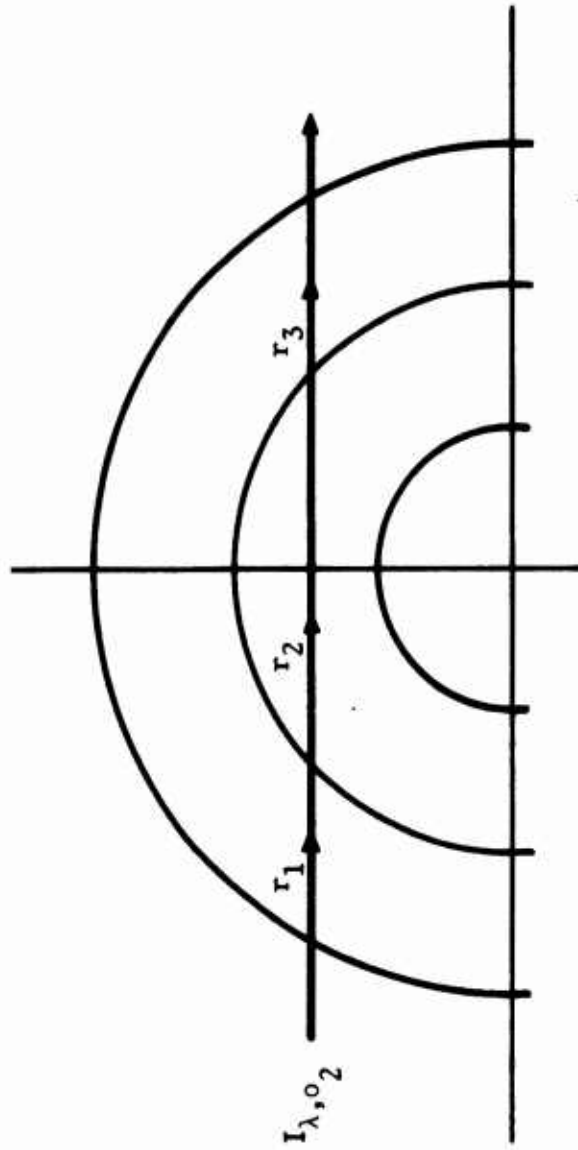

Figure 4. Ray Path Through Two Rings

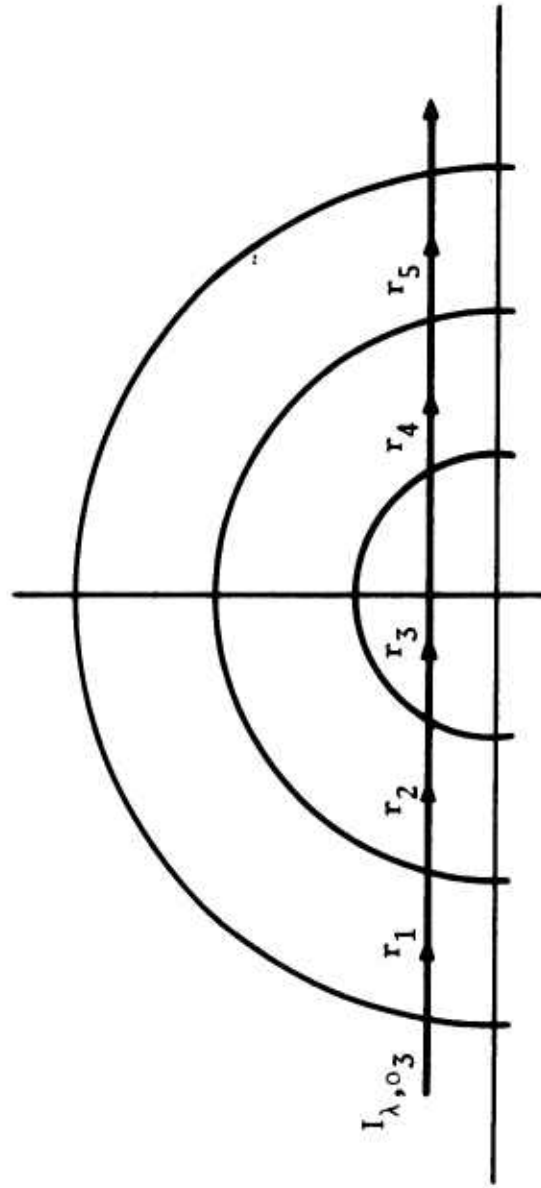

Figure 5. Ray Path Through Three Rings

Experimental Setup for Sodium
Line Reversal Plume Temperature Mapping

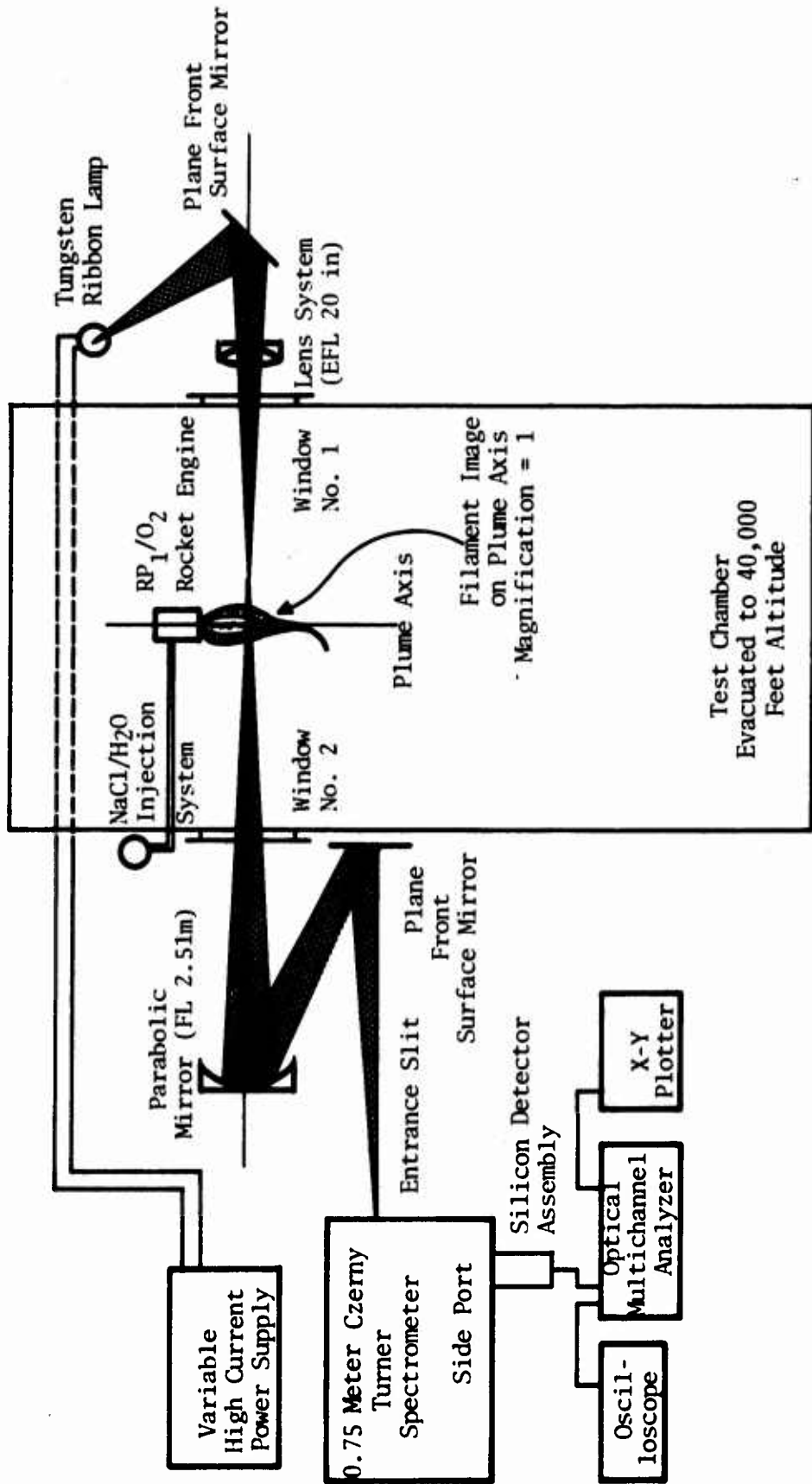

Figure 6. Imaging System

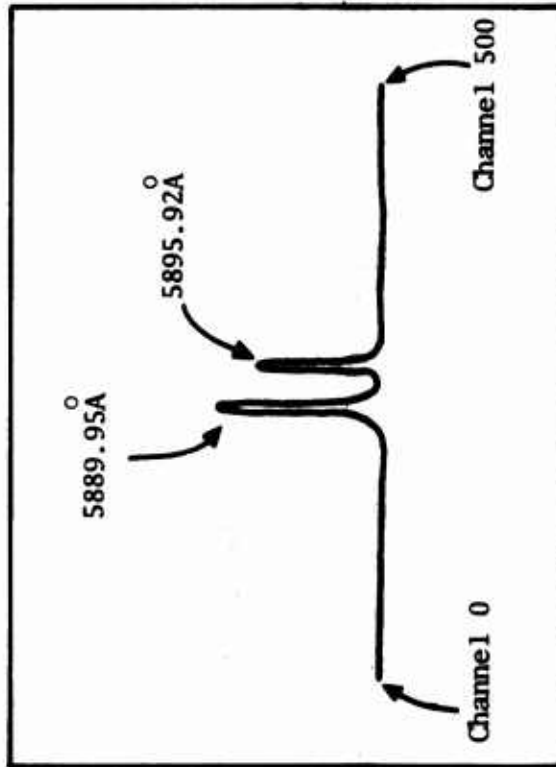
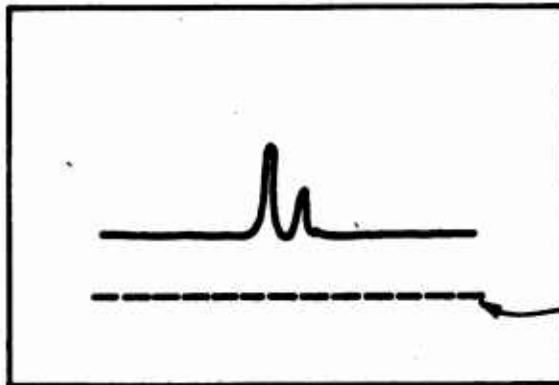

Figure 7. Oscilloscope Display for Sodium Doublet

Pre-Reversal Condition

A.



Zero Intensity Level

Post-Reversal Condition

B.

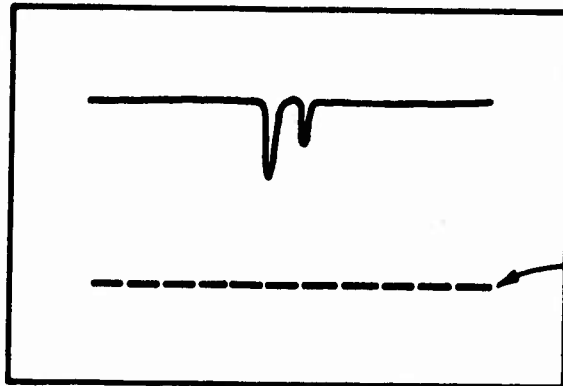

Zero Intensity Level

Figure 8. Oscilloscope Displays for Pre- and Post-Reversal

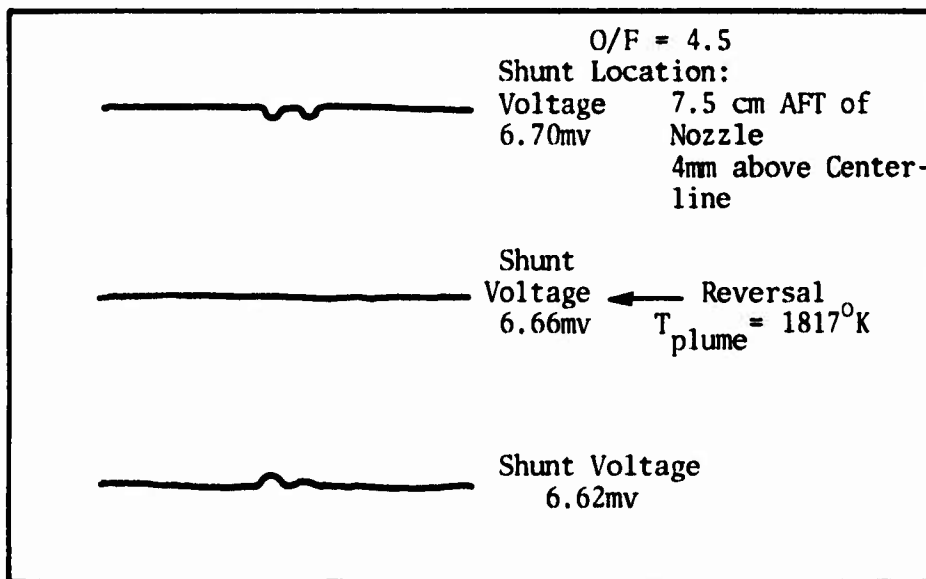

Figure 9. Sample Data Set

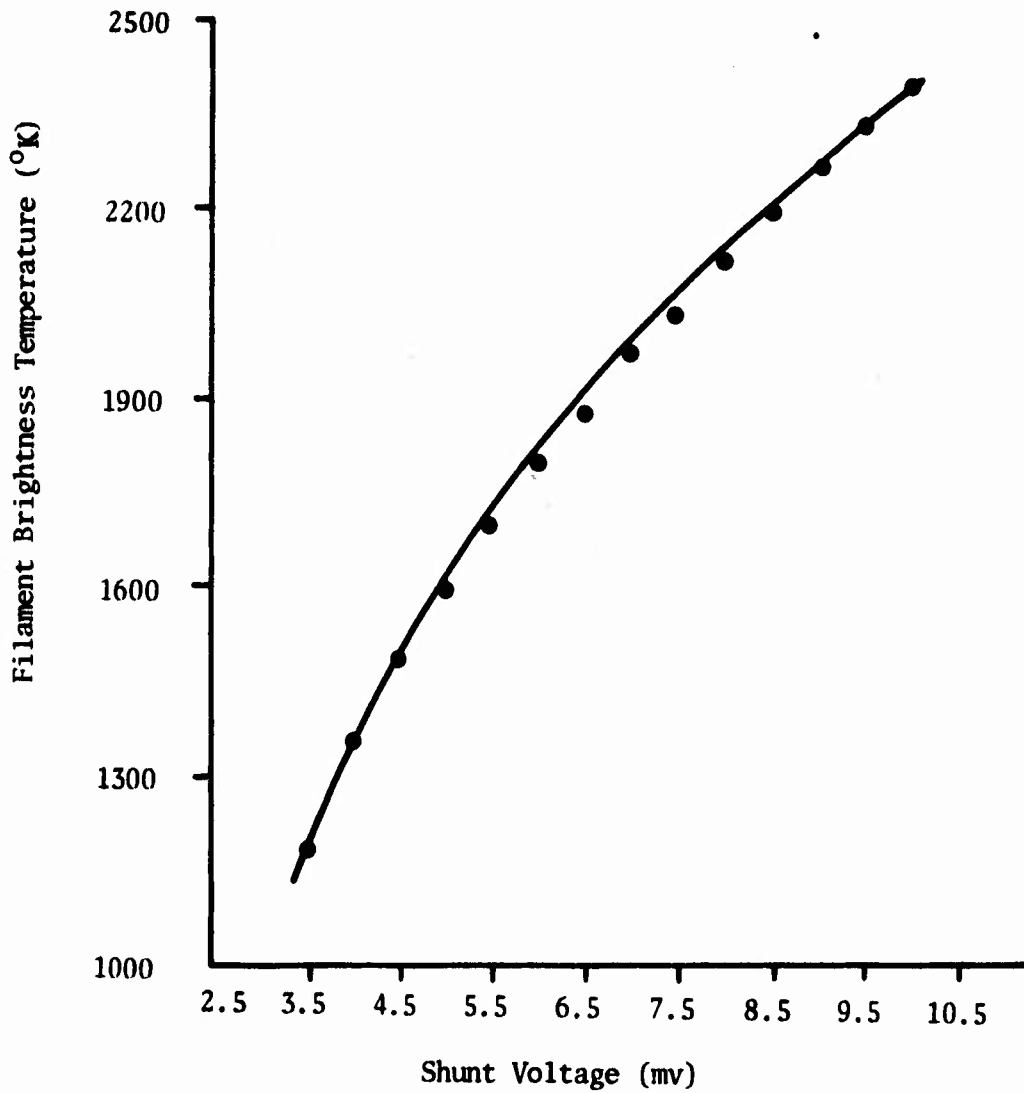

Figure 10. Tungsten Lamp Calibration Curve

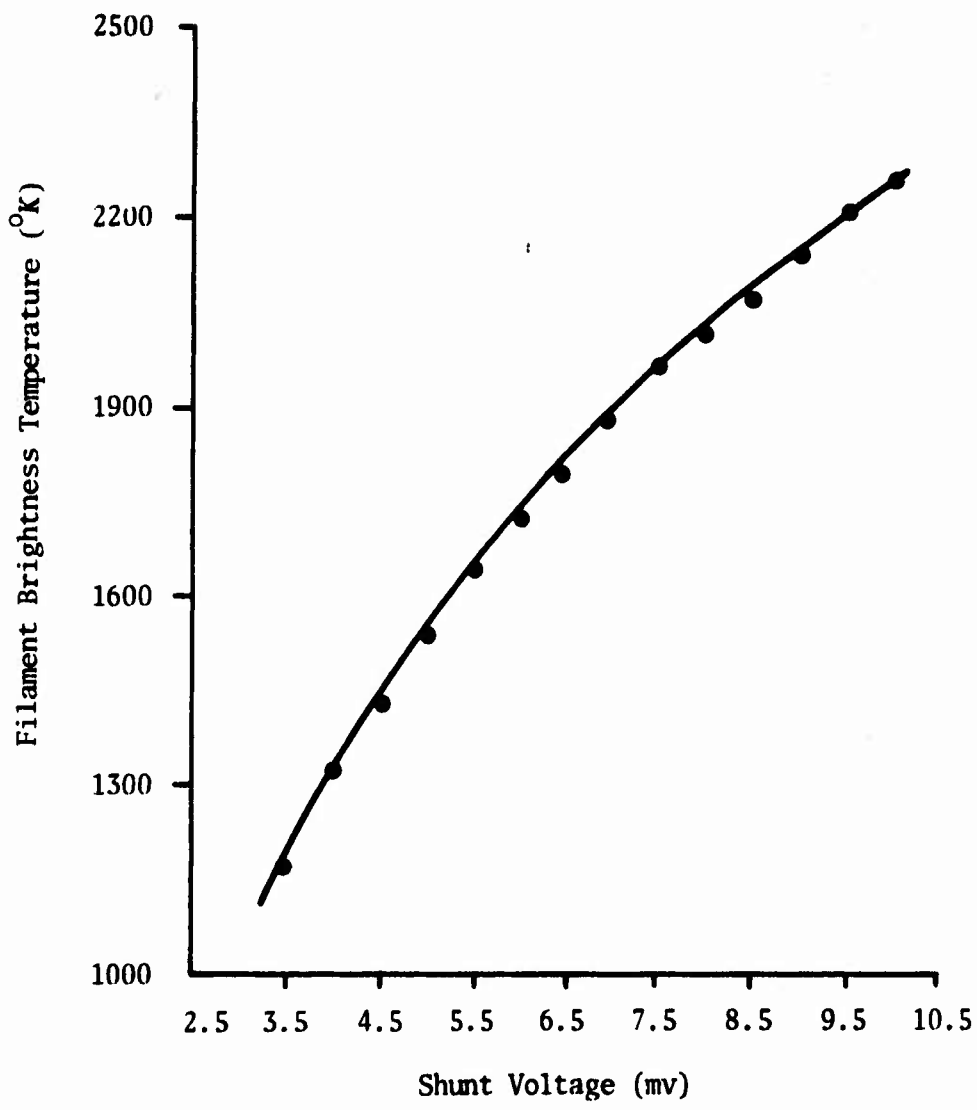
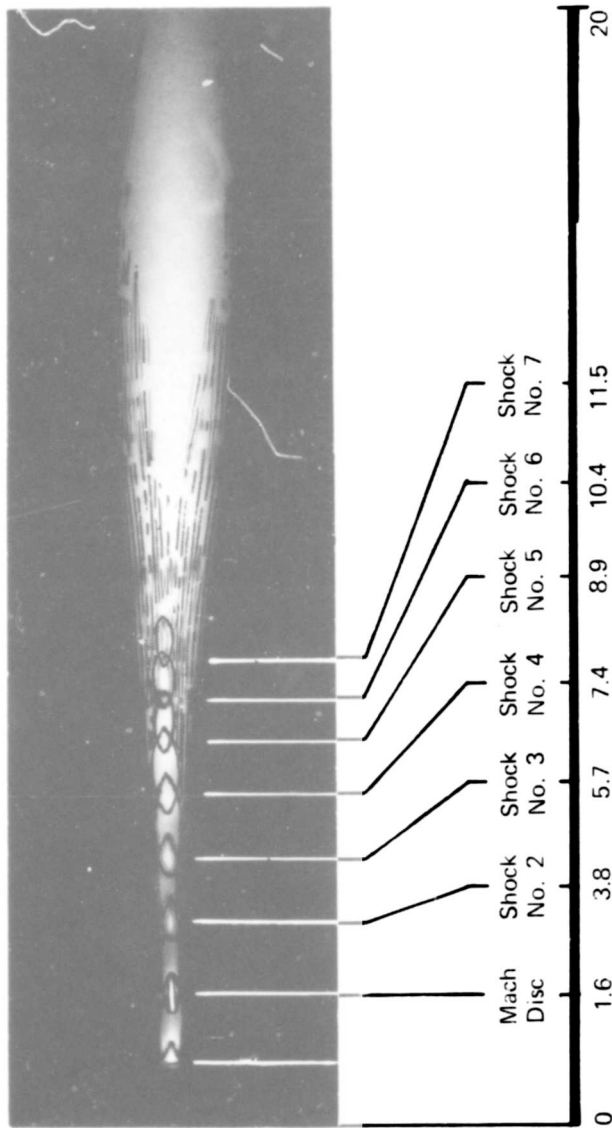

Figure 11. Filament Image Calibration Curve



$O/F = 2.0$

$P_c = 4 \text{ atm}$

$\dot{m}_t = 5 \text{ gm/sec}$

13.1 km, Static Air

Figure 12. Exhaust Plume

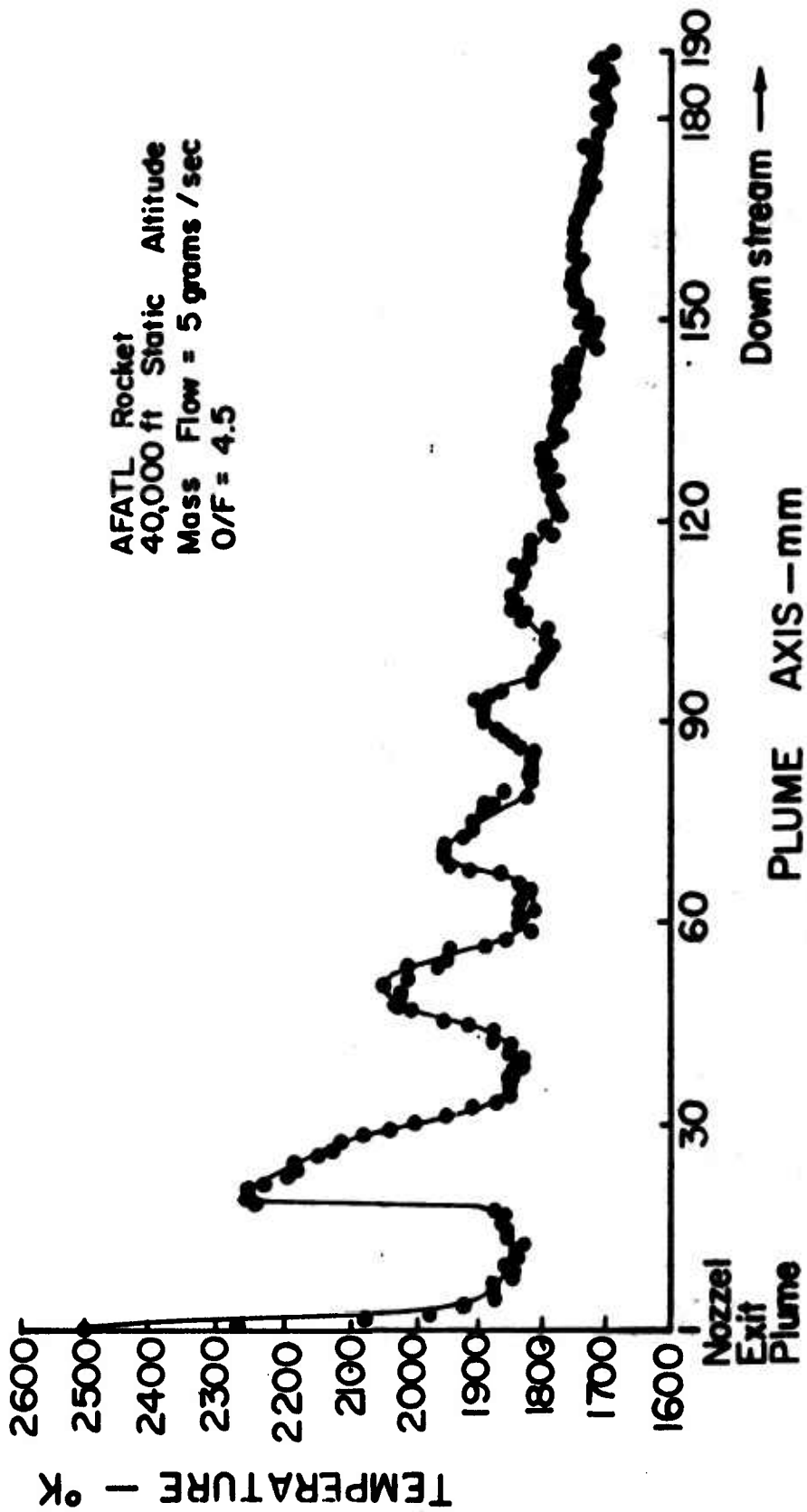

Figure 13. Centerline Temperature Distribution (O/F = 4.5)

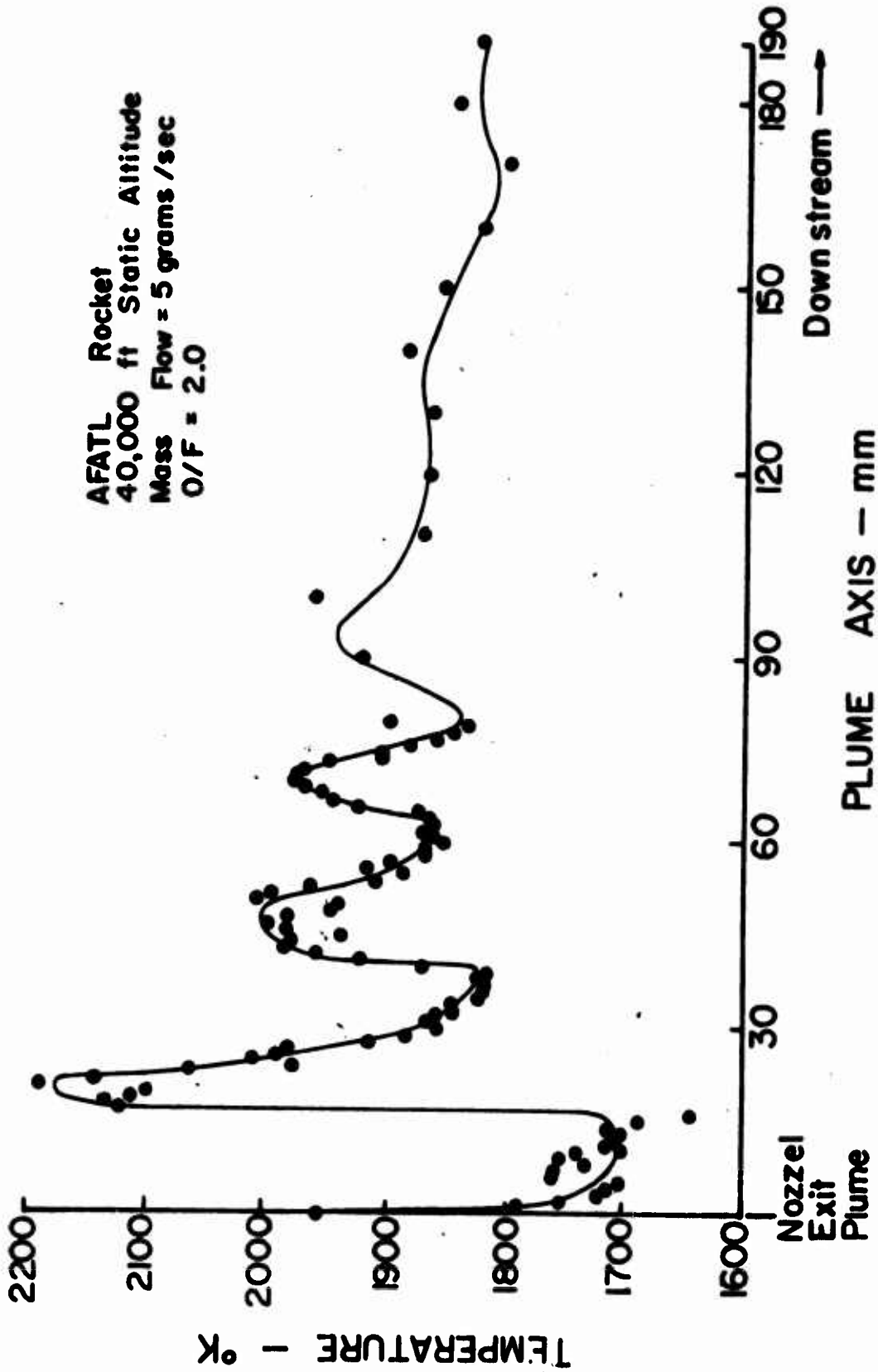

Figure 14. Centerline Temperature Distribution (O/F = 2.0)

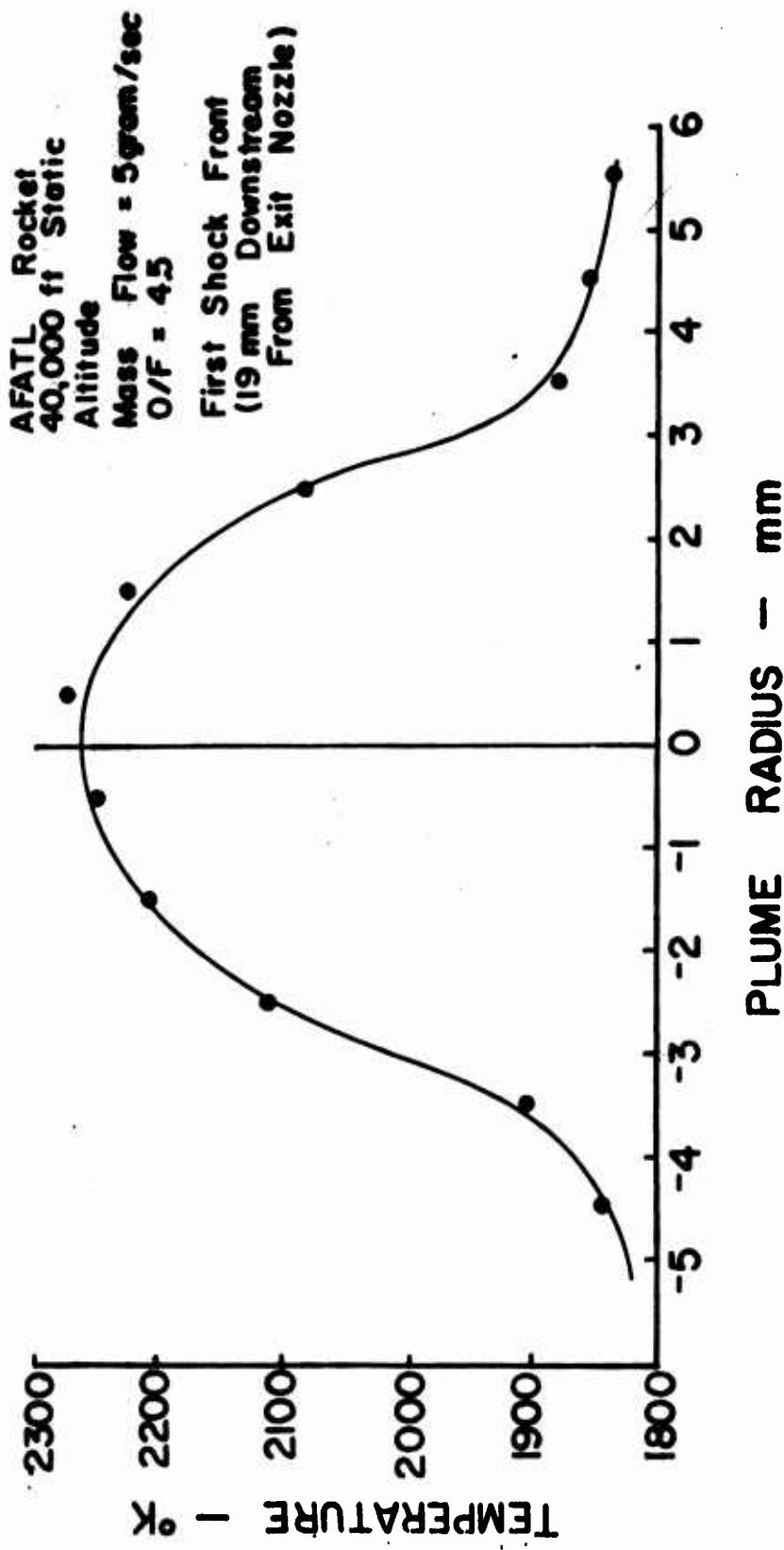

Figure 15. Radial Temperature Distribution (O/F = 4.5)

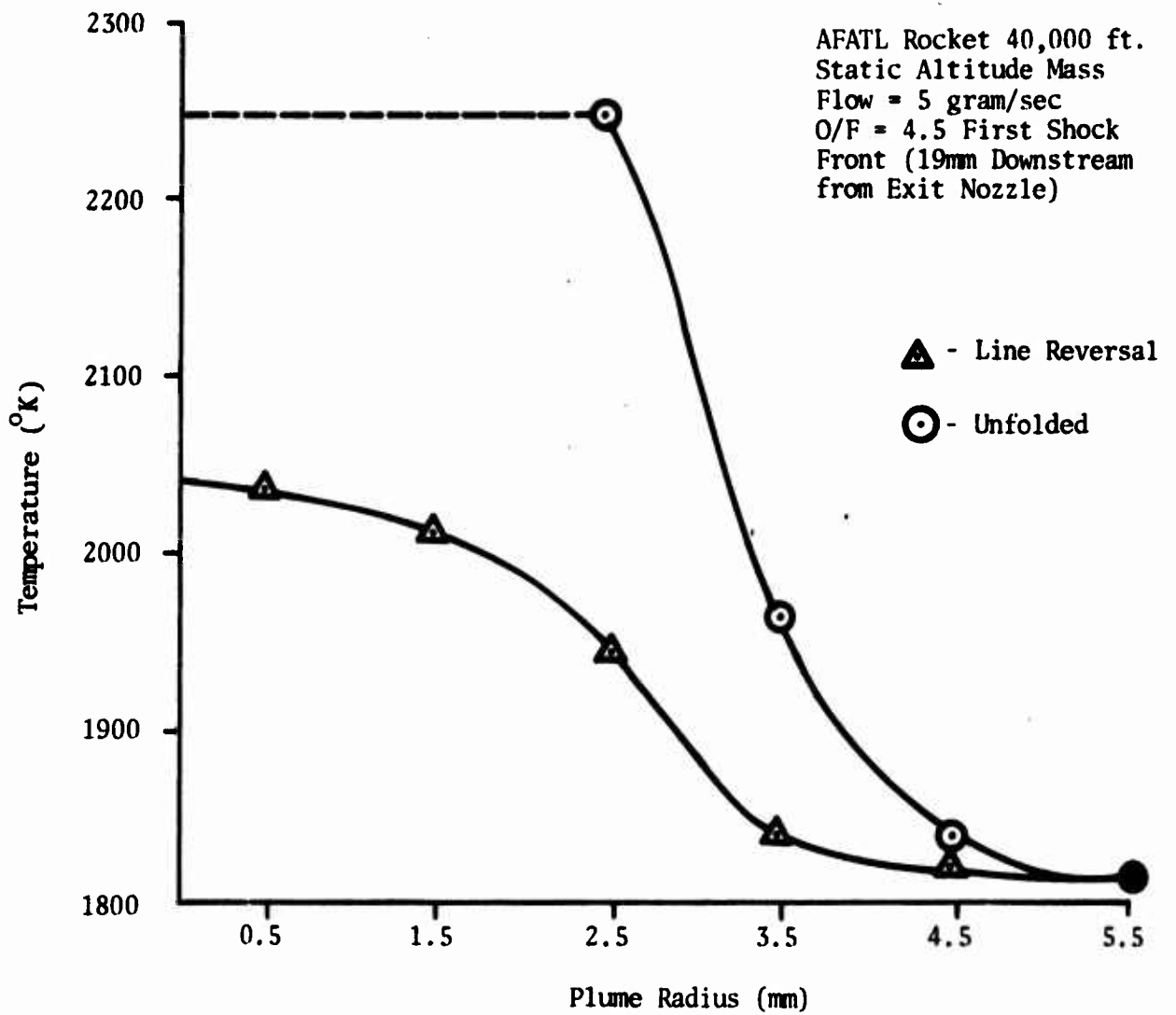

Figure 16. Unfolded Plume Temperature Distribution

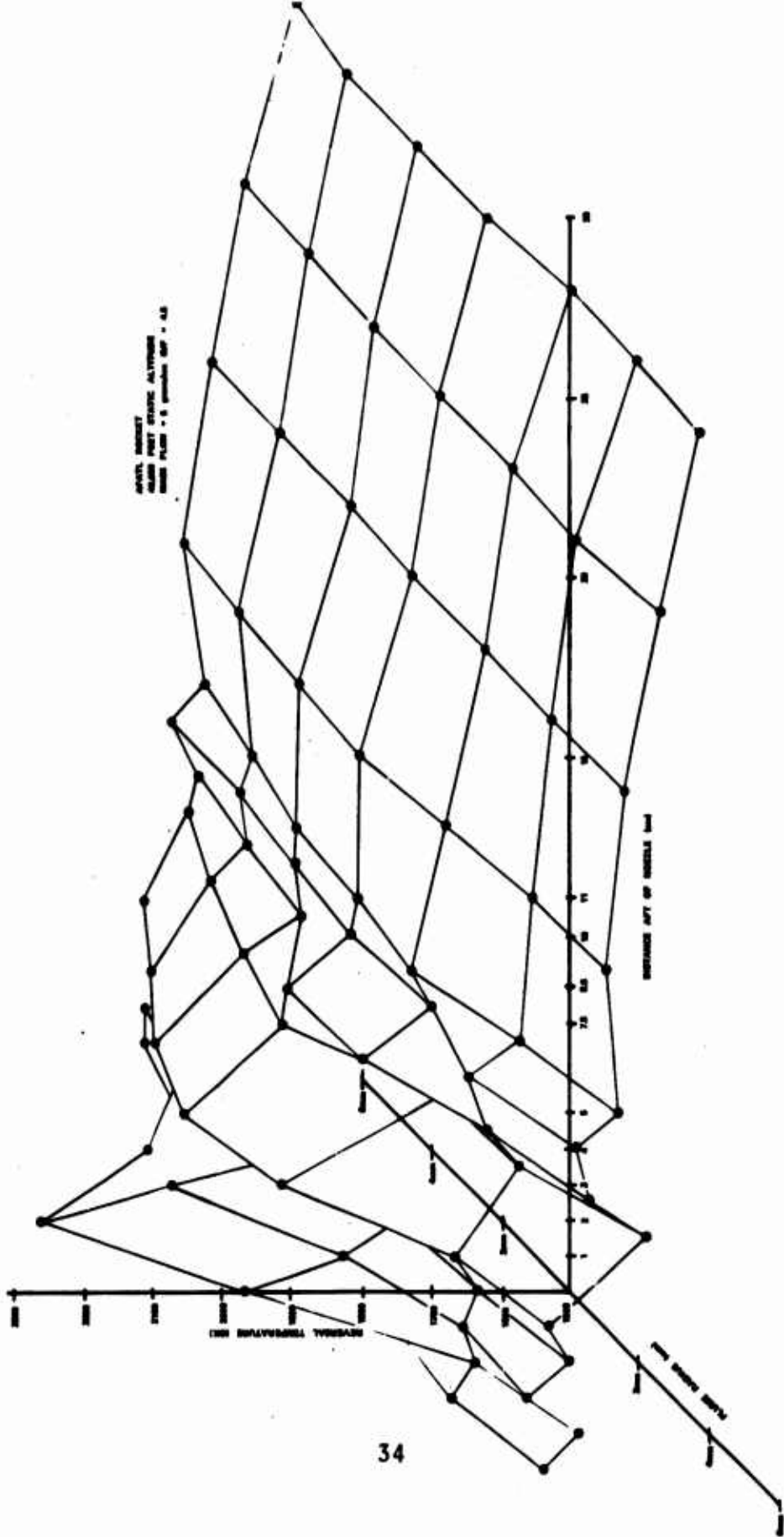

Figure 17. Temperature Map of Plume

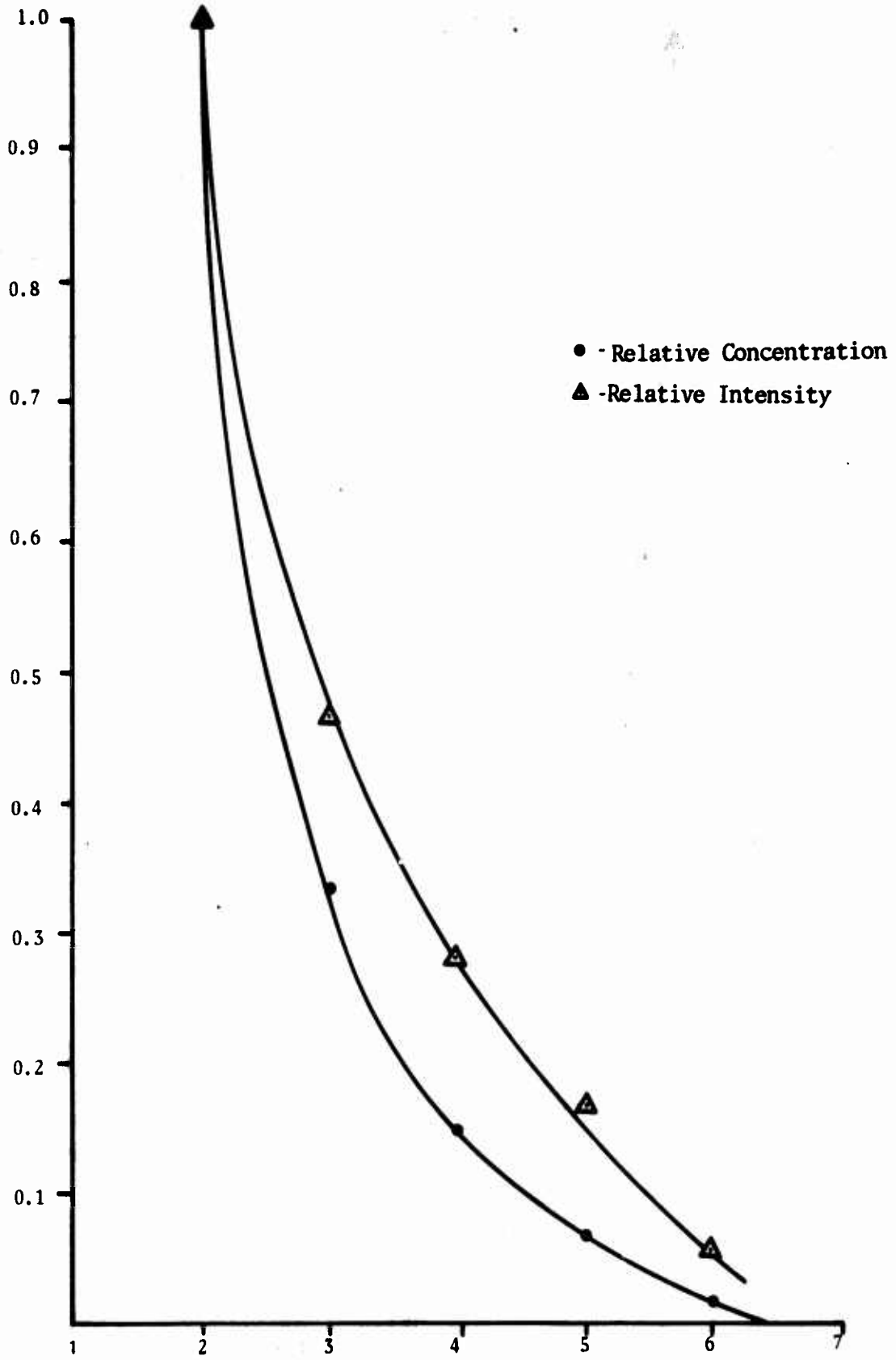

Figure 18. Relative OH Concentration Versus O/F Ratio

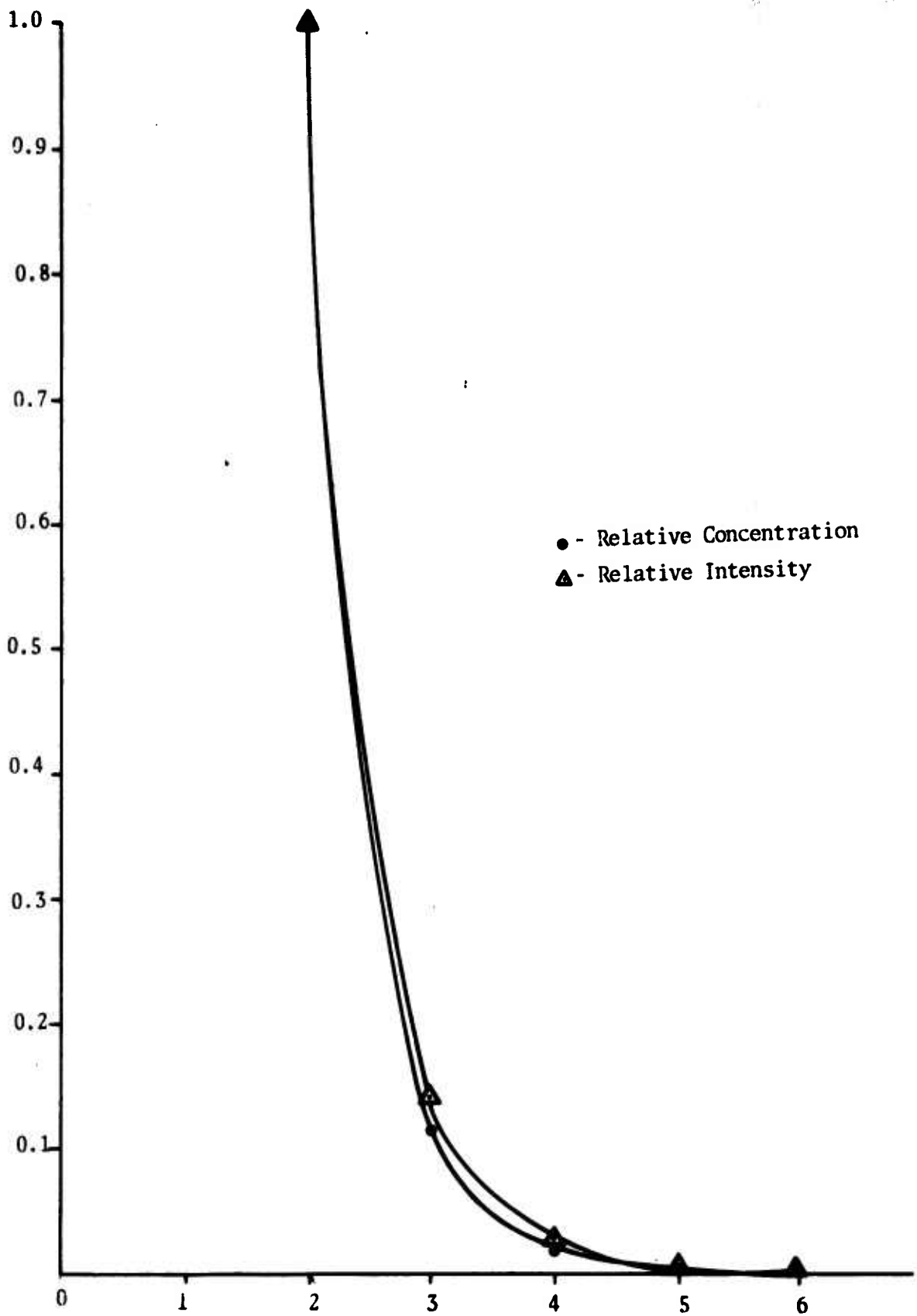

Figure 19. Relative CH Concentration Versus O/F Ratio

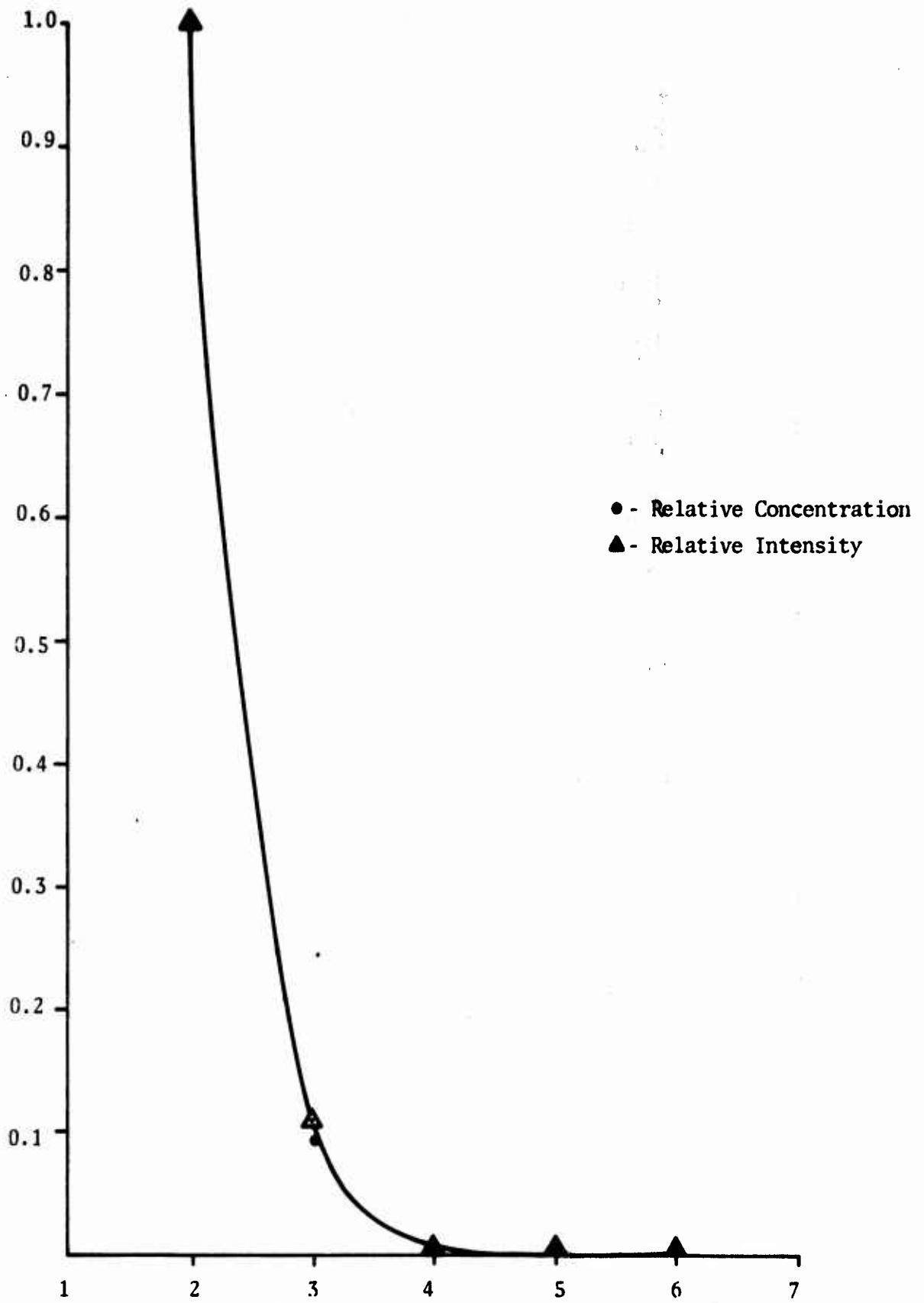

Figure 20. Relative C_2 Concentration Versus O/F Ratio

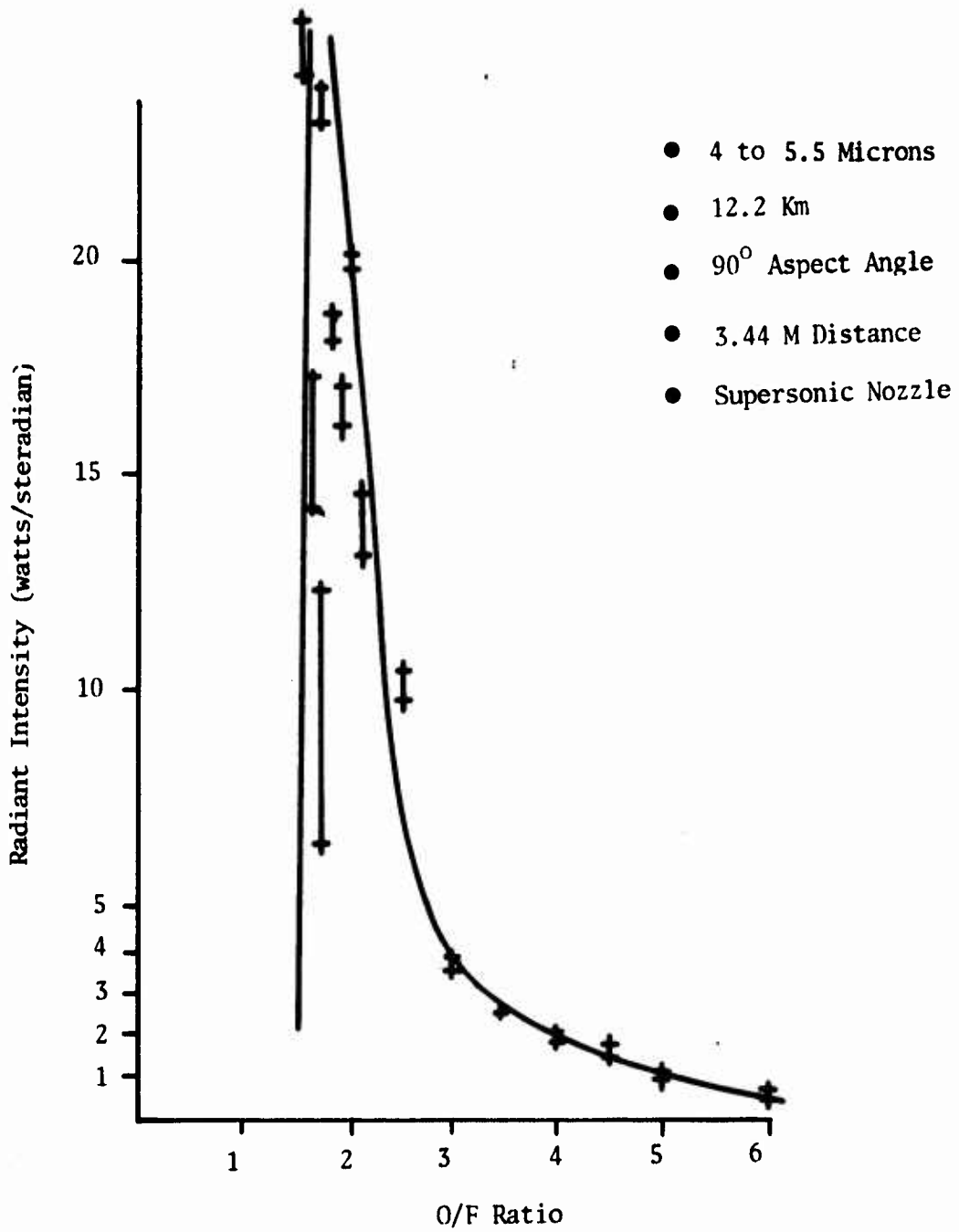

Figure 21. Infrared Radiant Intensity Versus O/F Ratio

REFERENCES

1. J. F. Long, Air Force Armament Laboratory Infrared Plume Simulation Capabilities, Air Force Technical Report No. AFATL-TR-76-26, Air Force Armament Laboratory, Eglin Air Force Base, Florida (May 1976).
2. A. Vamos, Non Equilibrium Effects in Kerosens/O₂ Rocket Nozzle Flows, Technical Report No. AE-75-4, University of Maryland, June 1975.
3. D. B. Ebeoglu and C. W. Martin, Effect of Mixture Ratio on UV. Visible and Infrared Radiation from Exhaust Plumes, Air Force Technical Report No. AFATL-TR-75-79, Air Force Armament Laboratory, Eglin Air Force Base, Florida, May 1975.
4. G. Herzberg, Molecular Spectra and Molecular Structure, D. Van Nostrand Company, Inc., Toronto, Canada, 1939.

APPENDIX A

DETERMINATION OF
SPECIES OF CONCENTRATIONS

CONCENTRATION

For the band-head line of a molecular band we have that

$$I = An^* e^{-E_n/KT}$$

where A is the transition coefficient and E_n is the energy of the upper state. n^* is the density of particles with electrons in energy state E_n .
So

$$I = I(n^*T).$$

Then

$$dI = \frac{\partial I}{\partial T} dT + \frac{\partial I}{\partial n^*} dn^*$$

where $\frac{\partial I}{\partial T} = An^* e^{-E_n/KT} \left(\frac{E_n}{KT^2} \right)$ and

$$\frac{\partial I}{\partial n^*} = Ae^{-E_n/KT}$$

so $dI = \frac{An^* E_n}{K} \frac{e^{-E_n/KT}}{T^2} dt + Ae^{-E_n/KT} dn^*$ and

$$\frac{dI}{I} = \frac{E_n}{K} \frac{dT}{T^2} + \frac{dn^*}{n^*}$$

Integrating

$$\int_{I_{\max}}^I \frac{dI}{I} + \frac{E_n}{K} \int_{T_{\min}}^T \frac{dT}{T^2} + \int_{n^*_{\max}}^n \frac{dn^*}{n^*} \quad \text{and finally}$$

$$\frac{I}{I_{\max}} = \exp \left[\frac{E_n}{K} \left(\frac{1}{T_{\min}} - \frac{1}{T} \right) \right] \left(\frac{n^*}{n^*_{\max}} \right)$$

$$\text{or } \frac{n^*}{n^*_{\max}} = \frac{I}{I_{\max}} \left[\exp \left(\frac{-E_n}{K} \right) \left(\frac{1}{T_{\min}} - \frac{1}{T} \right) \right]$$

$$\text{Then } n^*_{\text{rel}} = I_{\text{rel}} \left[\exp \left(\frac{-E_n}{K} \right) \left(\frac{1}{T_{\min}} - \frac{1}{T} \right) \right]$$

Thus, the connection between the relative intensity and relative concentration is established.

The relative intensity distribution is obtainable from previous measurements (Reference 3). The E_n are tabulated in the Appendix of Reference 4.

A distribution of the plume temperatures for O/F = 2 through O/F = 6 is obtained by fitting a straight line through two known temperatures. These temperatures were taken to be those measured by sodium line reversal at the first shock front of the plume at the O/F = 2 and O/F = 4.5 conditions.

APPENDIX B

PLUME TEMPERATURE
UNFOLDING TECHNIQUE

UNFOLDING TECHNIQUE

The plume geometry is shown in Figure B-1. The plume cutoff limit was determined photographically to be 7.26 mm from the plume centerline axis. With the exception of the outer ring, all rings have a thickness of 1 mm and data paths are taken through the center of each ring. Poor signal to noise ratio near the outer boundary of the plume prevented the use of a seven-ring system.

All path lengths were determined graphically from a scaled drawing of the plume.

For each path, the following procedure was followed: (1) intensity of the plasma only (I_p) was measured (5889Å) and (2) the tungsten ribbon lamp was increased past the reversal point and the baseline (I_L) and minimum (I_T) intensities were measured. The intensity displays and the tabulated intensities appear in Figure B-2.

A computer program was written in order to simplify the analysis of the data and this appears at the end of this appendix.

The outer ring is taken as ring 1. For data input

$$I_p(n) \rightarrow S(N)$$

$$I_T(n) \rightarrow T(n)$$

$$I_L(n) \rightarrow E(n)$$

The TLAMP (n) value corresponds to the measured line reversal temperatures through each respective path.

The computer output includes a list of the ring absorption coefficients [KAPPA (n)] and the ring temperatures [TEMP (n)].

For the plume data tabulated here the KAPPA (n) are seen to go negative in the fifth and sixth ring. This is caused by the fact that the plasma

is optically very thin ($\kappa \cdot l < 1$) and the fact that errors are compounded as the unfolding process advances toward the center ring. Ring temperatures may be obtained only for positive KAPPAS so the generated ring temperatures are useful only through the fourth ring. This indicates that the center temperature of the plume is at least that attained in the fourth ring (2697°K).

PLUME TEMPERATURE UNFOLDING PROGRAM

```

/list
0000 1 DIMENSION PATH(6,6),KAPPA(6),E(6),T(6),S(6),TERM(6),BPLAS(6),BLAMP
0001 1(6),A(6),V(6),TEMP(6),TLAMP(6)
0002 2 PSUM=0
0003 REAL KAPPA, LAMB, WAVE
0004 3 N=6
0005 $CUTOFF=2
0006 4 D07I=1,N
0007 5 D06J=1
0008 6 PATH(I,J)=0
0009 7 CONTINUE
0010 8 D012I=1,N
0011 9 KAPPA(I)=0
0012 10 E(I)=0
0013 11 T(I)=0
0014 12 CONTINUE
0015 13 MESSAGE'ENTER THE PATH (I,J) VALUES'
0016 14 D020I=1,N
0017 15 D019J=1,I
0018 16 MESSAGE'PATH SUB'
0019 17 WRITE(6)I,J
0020 18 MESSAGE'EQUALS'
0021 19 READ(5)PATH(I,J)
0022 20 CONTINUE
0023 21 MESSAGE'ENTER THE E(N) VALUES'
0024 22 D026I=1,N
0025 23 MESSAGE'E SUB'
0026 24 WRITE(6)I,J
0027 25 MESSAGE'EQUALS'
0028 26 READ(5)E(I)
0029 27 MESSAGE'ENTER THE T(N) VALUES'
0030 28 D032I=1,N
0031 29 MESSAGE'T SUB'
0032 30 WRITE(6)I
0033 31 MESSAGE'EQUALS'

```

```

0034
0035
0036
0037
0038
0039
0040
0041
0042
0043
0044
0045
0046
0047
0048
0049
0050
0051
0052
0053
0054
0055
0056
0057
0058
0059
0060
0061
0062
0063
0064
0065
0066
0067
0068
0069
0070

32 READ(5)T(I)
33 MESSAGE'ENTER THE S(N) VALUES'
34 D038I=1,N
35 MESSAGE'S SUB'
36 WRITE(6)I
37 MESSAGE'EQUALS'
38 READ(5)S(I)
39 D045I=1,N
40 TERM(I)=(ALOG(E(I)/(T(I)-S(I))))/(2*PATH(I,I))
41 D043J=1,I-1
42 PSUM=PSUM+(KAPPA(J)*PATH(I,J))
43 CONTINUE
44 KAPPA(I)=TERM(I)-(PSUM/PATH(I,I))
45 PSUM=0
46 MESSAGE' THE KAPPA VALUES APPEAR BELOW'
47 D051I=1,N
48 MESSAGE'KAPPA SUB'
49 WRITE(6)I
50 MESSAGE'EQUALS'
51 WRITE(6)KAPPA(I)
52 D058J=1,N
53 BPLAS(J)=0
54 BLAMP(J)=0
55 A(J)=0
56 V(J)=0
57 TEMP(J)=0
58 CONTINUE
59 MESSAGE 'ENTER LAMBDA DESIRED IN ANGSTROMS'
60 READ(5)LAMB
61 MESSAGE 'ENTER TEMPERATURE OF OUTER RING IN DEGREES KELVIN'
62 READ(5)TEMP(I)
63 MESSAGE 'ENTER THE TLAMP VALUES'
64 D069J=1,N
65 MESSAGE'TLAMP SUB'
66 WRITE(6) J
67 MESSAGE'EQUALS'
68 READ(5)TLAMP(J)

```

```

0071 69 CONTINUE
0072 70 D073J=1,N
0073 71 WAVE=(LAMB)*1.E-8
0074 72 BLAMP(J)=(1.191E-5)*(WAVE**5)/(EXP(1.4388/WAVE/TLAMP(J)))
0075 73 CONTINUE
0076 74 BPLAS(1)=BLAMP(1)
0077 75 D085I=2,N
0078 76 A(1)=BPLAS(1)*(1-EXP((-1)*(KAPPA(1))*(PATH(I,1))))+BLAMP(1)*(EXP((
0079 1-1)*(KAPPA(1))*(PATH(I,1)))
0080 77 D079J=2, I-1
0081 78 A(J)=BPLAS(J)*(1-EXP((-1)*(KAPPA(J))*(PATH(I,J))))+A(J-1)*(EXP((-1
0082 1)*(KAPPA(J))*(PATH(I,J))))
0083 79 CONTINUE
0084 80 V(1)=(BLAMP(1)-((BPLAS(1))*(1-EXP((-1)*(KAPPA(1))*(PATH(I,1))))))/
0085 1(EXP((-1)*(KAPPA(1))*(PATH(I,1))))
0086 81 D083J=2, I-1
0087 82 V(J)=(V(J-1)-((BPLAS(J))*(1-EXP((-1)*(KAPPA(J))*(PATH(I,J))))))/(E
0088 IXP((-1)*(KAPPA(J))*(PATH(I,J))))
0089 83 CONTINUE
0090 84 BPLAS(1)=(V(1-1)-(A(1-1)*(EXP((-2)*(KAPPA(1))*(PATH(I,1))))))/(1-E
0091 IXP((-2)*(KAPPA(1))*(PATH(I,1)))
0092 85 CONTINUE
0093 86 D088J=1,N
0094 WAVE=LAMB*1.E-8
0095 87 TEMP(J)+C1.4388/WAVE*(1/ALOG((1.19E-5)*(WAVE**5)/BPLAS(J))+1))
0096 88 CONTINUE
0097 89 D094J=1,N
0098 90 MESSAGE 'TEMP SUB'
0099 91 WRITE(6)J
0100 92 MESSAGE'EQUALS'
0101 93 WRITE(6)TEMP(J)
0102 94 CONTINUE
0103 95 END
END OF WORK FILE

```

DATA INPUT (PATH VALUES)

BEGIN COMPILATION	134		
ENTER THE PATH (I,J) VALUES			
PATH SUB			
I= 1 J= 1			
EQUALS			
021	19	READ(5)PATH(I,J)	
			.123
PATH SUB			
I= 4 J= 2			
EQUALS			
021	19	READ(5)PATH(I,J)	
			.226
PATH SUB			
I= 6 J= 1			
EQUALS			
021	19	READ(5)PATH(I,J)	
			.103
PATH SUB			
I= 6 J= 2			
EQUALS			
021	19	READ(5)PATH(I,J)	
			.102
PATH SUB			
I= 6 J= 3			
EQUALS			
021	19	READ(5)PATH(I,J)	
			.106
PATH SUB			
I= 6 J= 4			
EQUALS			
021	19	READ(5)PATH(I,J)	
			.102
PATH SUB			
I= 6 J= 5			
EQUALS			
021	19	READ(5)PATH(I,J)	
			.106
PATH SUB			
I= 6 J= 6			
EQUALS			
021	19	READ(5)PATH(I,J)	
			.086
ENTER THE E(N) VALUES			
E SUB			
I= 1			
EQUALS			
028	26	READ(5)E(I)	
			.195

PATH SUB			
I= 4 J= 2			
EQUALS			
021	19	READ(5)PATH(I,J)	
			.123
PATH SUB			
I= 4 J= 3			
EQUALS			
021	19	READ(5)PATH(I,J)	
			.146
PATH SUB			
I= 4 J= 4			
EQUALS			
021	19	READ(5)PATH(I,J)	
			.164
PATH SUB			
I= 5 J= 1			
EQUALS			
021	19	READ(5)PATH(I,J)	
			.233
PATH SUB			
I= 5 J= 2			
EQUALS			
021	19	READ (5) PATH(I,J)	
			.106
PATH SUB			
I= 5 J= 3			
EQUALS			
021	19	READ(5)PATH(I,J)	
			.111
PATH SUB			
I= 5 J= 4			
EQUALS			
021	19	READ(5)PATH(I,J)	
			.128
PATH SUB			
I= 5 J= 5			
EQUALS			
021	19	READ(5)PATH(I,J)	
			.130

INPUT (LINE REVERSAL TEMPERATURES)

ENTER LAMBDA DESIRED IN ANGSTROMS
038 60 READ(5)LAMB
5889.95
ENTER TEMPERATURE OF OUTER RING IN DEGREES DELVIN
040 62 READ(5)TEMP(1)
1833
ENTER THE TLAMP VALUES
TLAMP SUB
J= 1
EQUALS
046 68 READ(5)TLAMP(J)
1833
TLAMP SUB
J= 2
EQUALS
046 68 READ(5)TLAMP(J)
1852
TLAMP SUB
J= 3
EQUALS
046 68 READ(5)TLAMP(J)
1877
TLAMP SUB
J= 5
EQUALS
046 68 READ(5)TLAMP(J)
2222
TLAMP SUB
J= 6
EQUALS
046 68 READ(5)TLAMP(J)
2272

OUTPUT (KAPPA VALUES)

THE KAPPA VALUES APPEAR BELOW

KAPPA SUB
I= 1
EQUALS
KAPPA(1)= 0.485485
KAPPA SUB
I= 2
EQUALS
KAPPA(2)= 0.607077
KAPPA SUB
I= 3
EQUALS
KAPPA(3)= 0.561228E-01
KAPPA SUB
I= 4
EQUALS
KAPPA(4)= 0.6684593-01
KAPPA SUB
I= 5
EQUALS
KAPPA(5)= -0.964486
KAPPA SUB
I= 6
EQUALS
KAPPA(6)= -0.326086

DATA INPUT (INTENSITY VALUES)

E SUB					
I= 2					
EQUALS					
028	26 READ(5)E(I)		32 READ(5)T(I)		38 READ(5)S(I)
<u>201</u>					
E SUB					
I= 3					
EQUALS					
028	26 READ(5)E(I)		32 READ(5)T(I)		38 READ(5)S(I)
213					
E SUB					
I= 4					
EQUALS					
028	26 READ(5)E(I)		32 READ(5)T(I)		38 READ(5)S(I)
<u>396</u>					
E SUB					
I= 5					
EQUALS					
028	26 READ(5)E(I)		32 READ(5)T(I)		38 READ(5)S(I)
<u>679</u>					
E SUB					
I= 6					
EQUALS					
028	26 READ(5)E(I)		32 READ(5)T(I)		38 READ(5)S(I)
<u>881</u>					
ENTER THE T(N) VALUES					
T SUB					
I= 1					
EQUALS					
034	26 READ(5)E(I)		38 READ(5)S(I)		
<u>139</u>					
T SUB					
I= 2					
EQUALS					
034	32 READ(5)T(I)				
<u>127</u>					
T SUB					
I= 3					
EQUALS					
034	32 READ(5)T(I)				
<u>127</u>					
T SUB					
I= 3					
EQUALS					
034	32 READ(5)T(I)				
<u>153</u>					
T SUB					
I= 4					
EQUALS					
034	32 READ(5)T(I)				
<u>310</u>					
T SUB					
I= 5					
EQUALS					
034	32 READ(5)T(I)				
<u>660</u>					
T SUB					
I= 6					
EQUALS					
034	32 READ(5)T(I)				
<u>860</u>					
ENTER THE S(N) VALUES					
S SUB					
I= 1					
EQUALS					
040	38 READ(5)S(I)				
<u>17</u>					
S SUB					
I= 2					
EQUALS					
040	38 READ(5)S(I)				
<u>17</u>					
S SUB					
I= 3					
EQUALS					
040	38 READ(5)S(I)				
<u>23</u>					
S SUB					
I= 4					
EQUALS					
040	38 READ(5)S(I)				
<u>52</u>					
S SUB					
I= 5					
EQUALS					
040	38 READ(5)S(I)				
<u>66</u>					
S SUB					
I= 6					
EQUALS					
040	38 READ(5)S(I)				
<u>70</u>					

OUTPUT (RING TEMPERATURES)

TEMP SUB
J= 1
EQUALS
TEMP(1)= 1833.11
TEMP SUB
J= 2
EQUALS
TEMP(2)= 1874.55
TEMP SUB
J= 3
EQUALS
TEMP(3)= 2126.75
TEMP SUB
J= 4
EQUALS
TEMP(4)= 2696.90

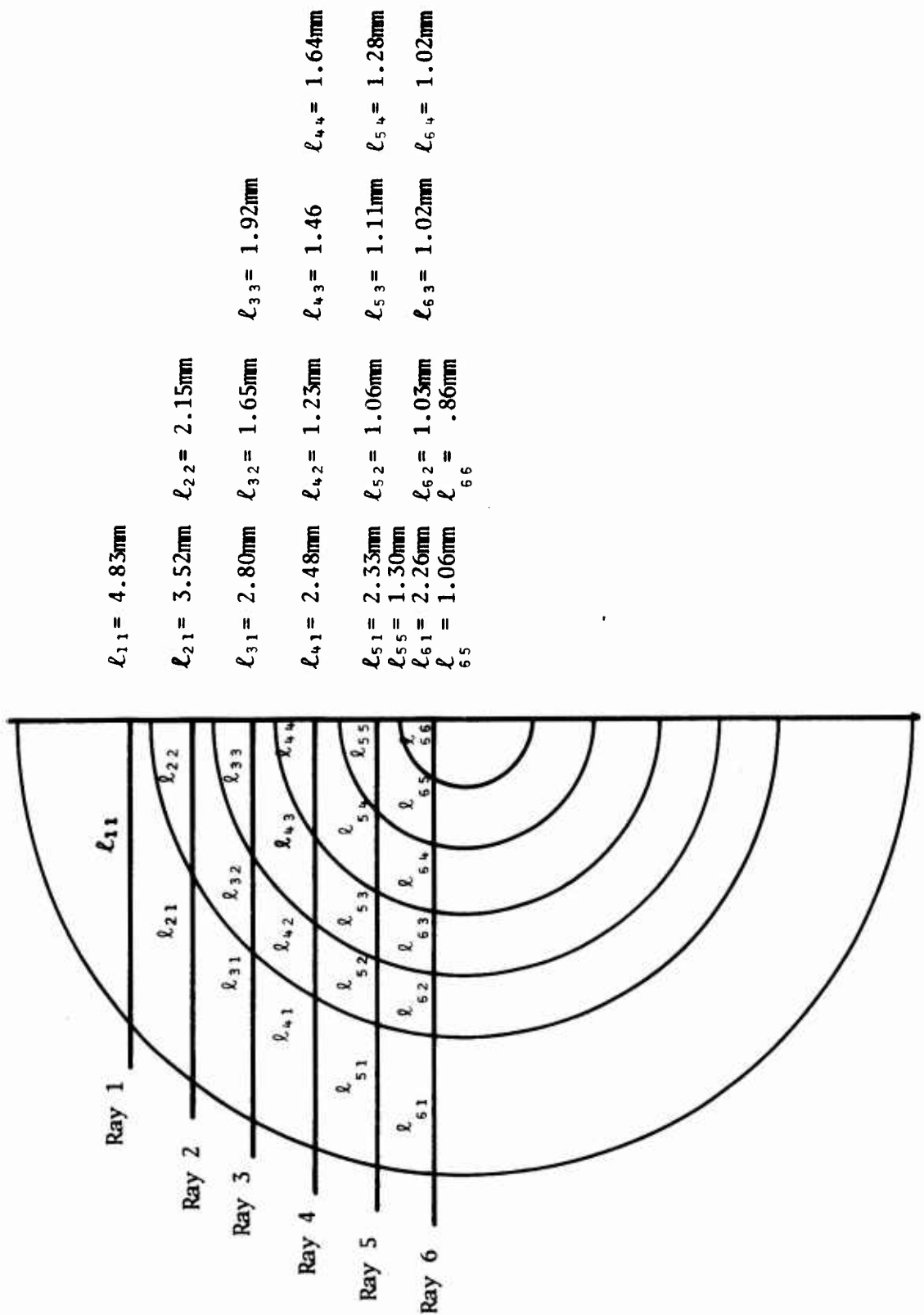
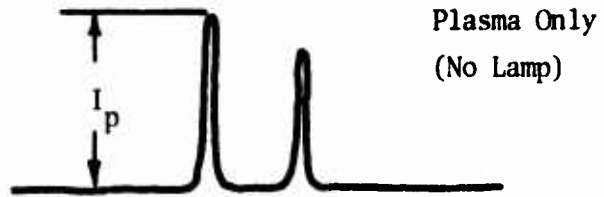

Figure B-1. Plume Geometry

All Intensities in Relative Units

$I_p(1) = 17$
 $I_p(2) = 17$
 $I_p(3) = 23$
 $I_p(4) = 52$
 $I_p(5) = 66$
 $I_p(6) = 70$



$I_L(1) = 195$	$I_T(1) = 139$
$I_L(2) = 201$	$I_T(2) = 127$
$I_L(3) = 213$	$I_T(3) = 153$
$I_L(4) = 396$	$I_T(4) = 310$
$I_L(5) = 679$	$I_T(5) = 660$
$I_L(6) = 881$	$I_T(6) = 860$

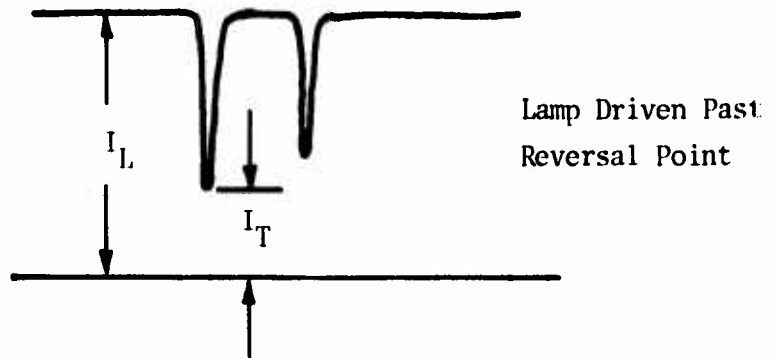

Figure B-2. Data Collection Technique

APPENDIX C
RADIAL TEMPERATURE
SCANS

AFATL Rocket 40,000
Feet Static Altitude
Mass Flow = 5.0 grams/sec
O/F = 4.5
1.0 cm Aft of Nozzle

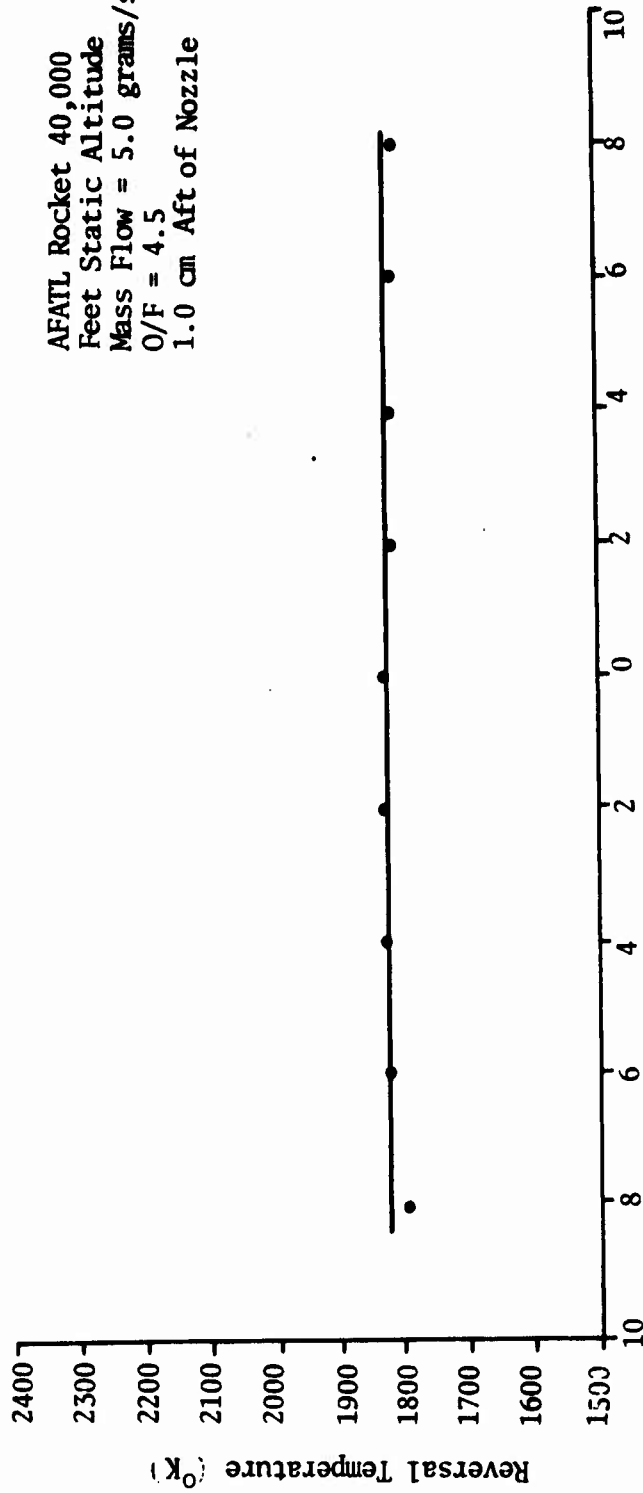

Figure C-1. Radial Temperature Scan (1.0 cm Aft of Rocket Nozzle)

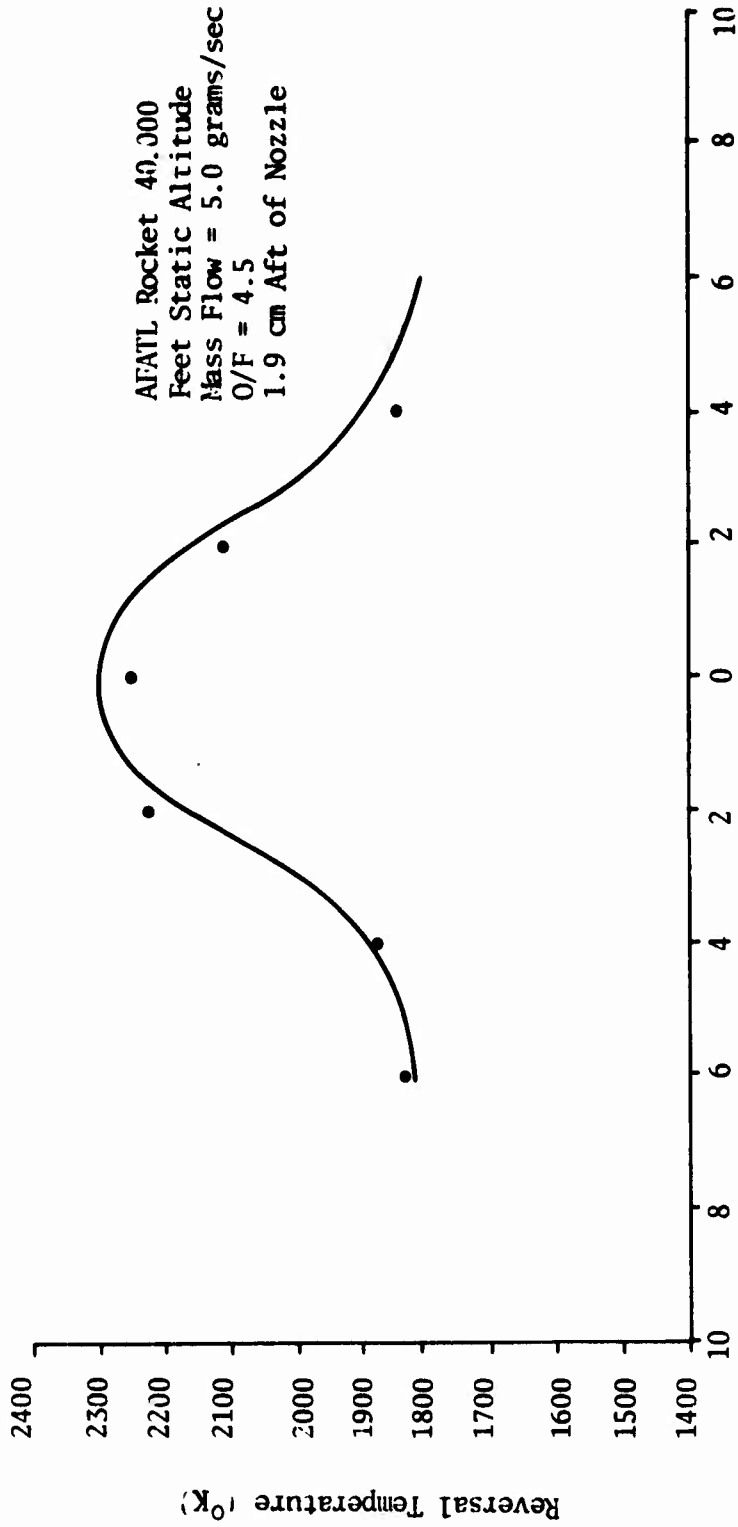

Figure C-2. Radial Temperature Scan (1.9 cm Aft of Rocket Nozzle)

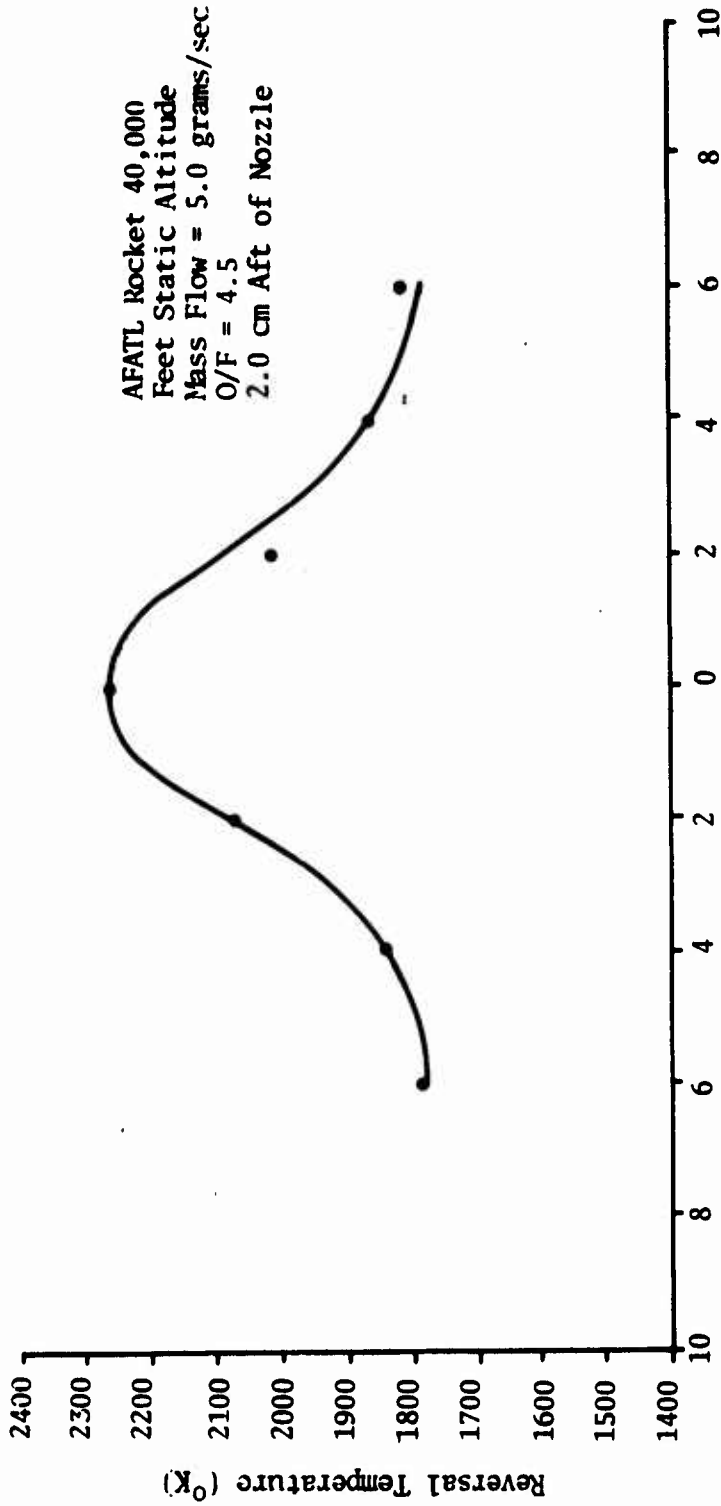

Figure C-3. Radial Temperature Scan (2.0 cm Aft of Rocket Nozzle)

AFATL Rocket 40,000
Feet Static Altitude
Mass Flow = 5.0 gram/sec
O/F = 4.5
3.0 cm Aft of Nozzle

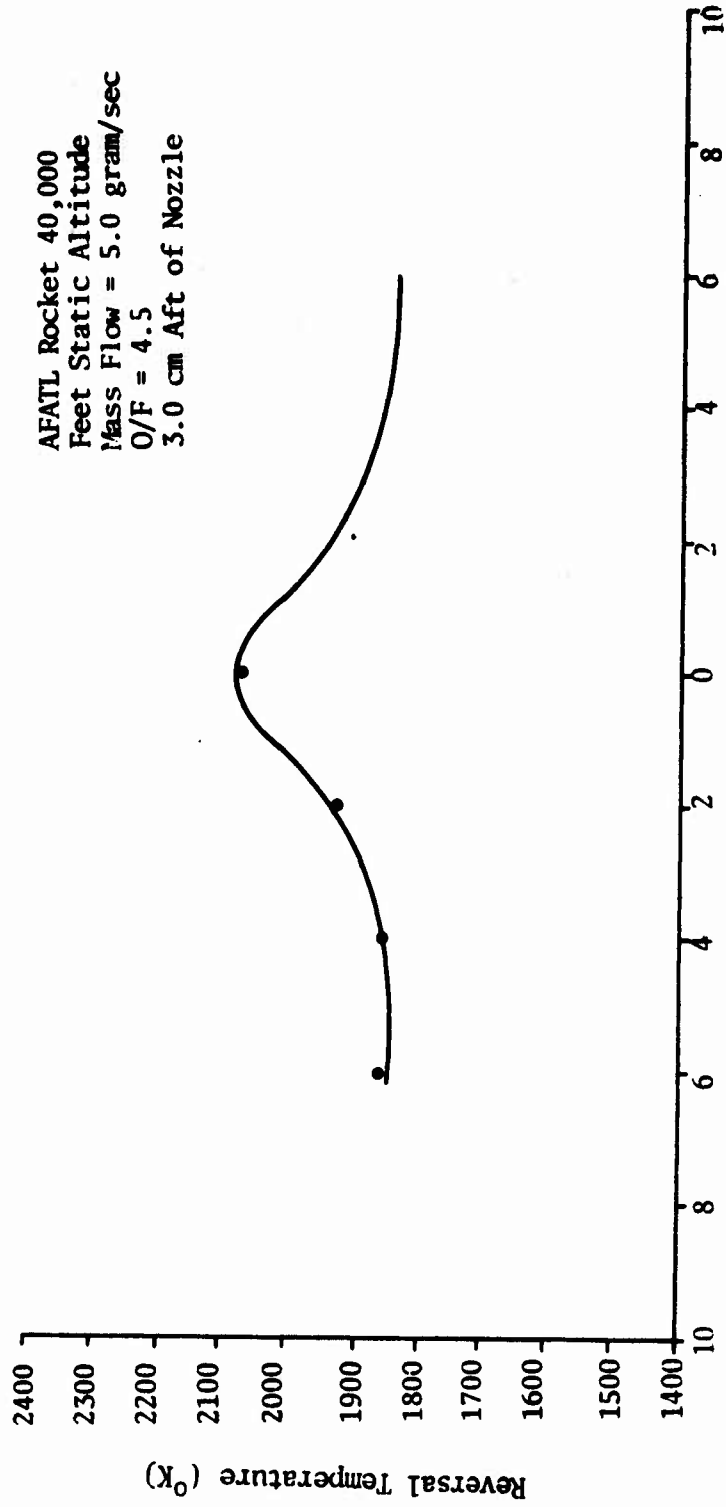

Figure C-4. Radial Temperature Scan (3.0 cm Aft of Rocket Nozzle)

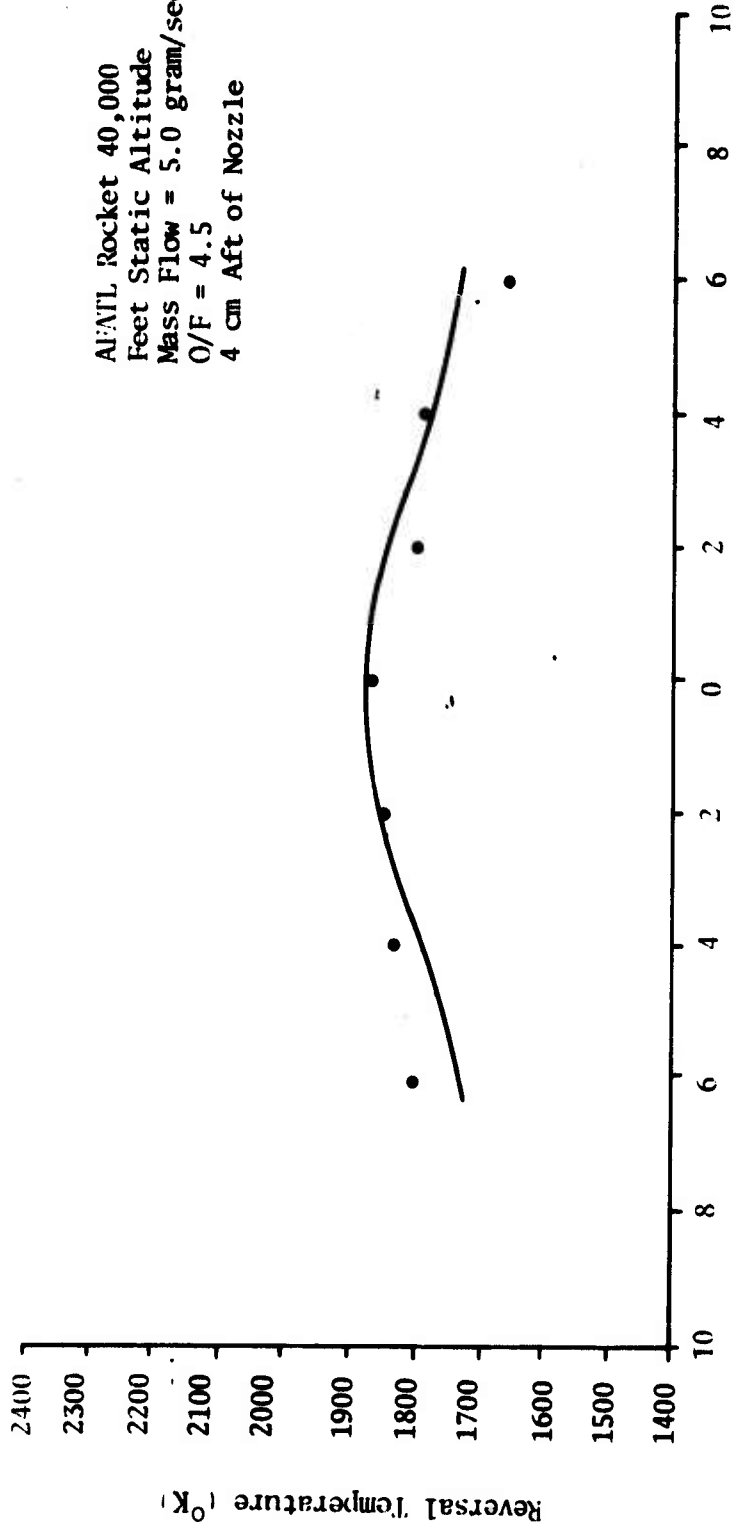

Figure C-5. Radial Temperature Scan (4 cm Aft of Rocket Nozzle)

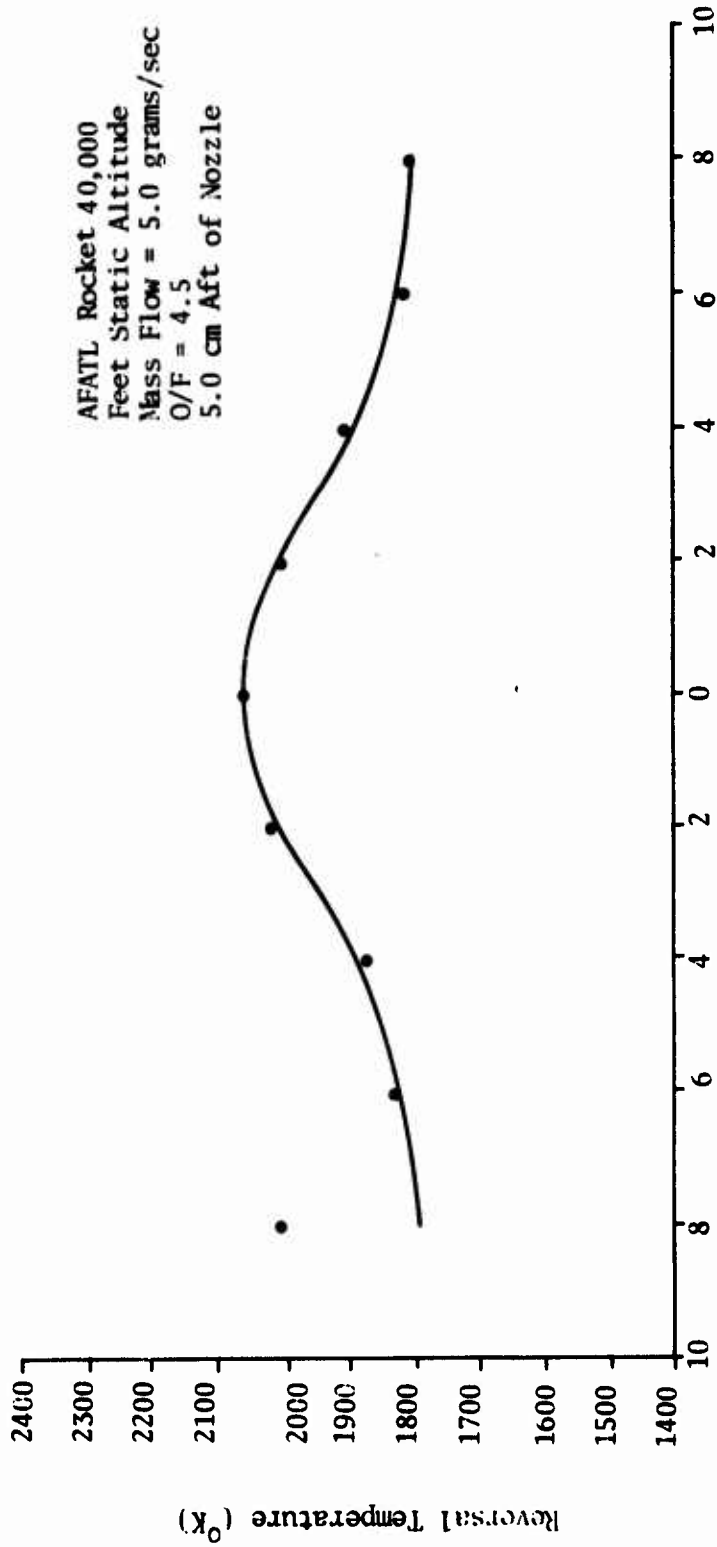

Figure C-6. Radial Temperature Scan (5.0 cm Aft of Rocket Nozzle)

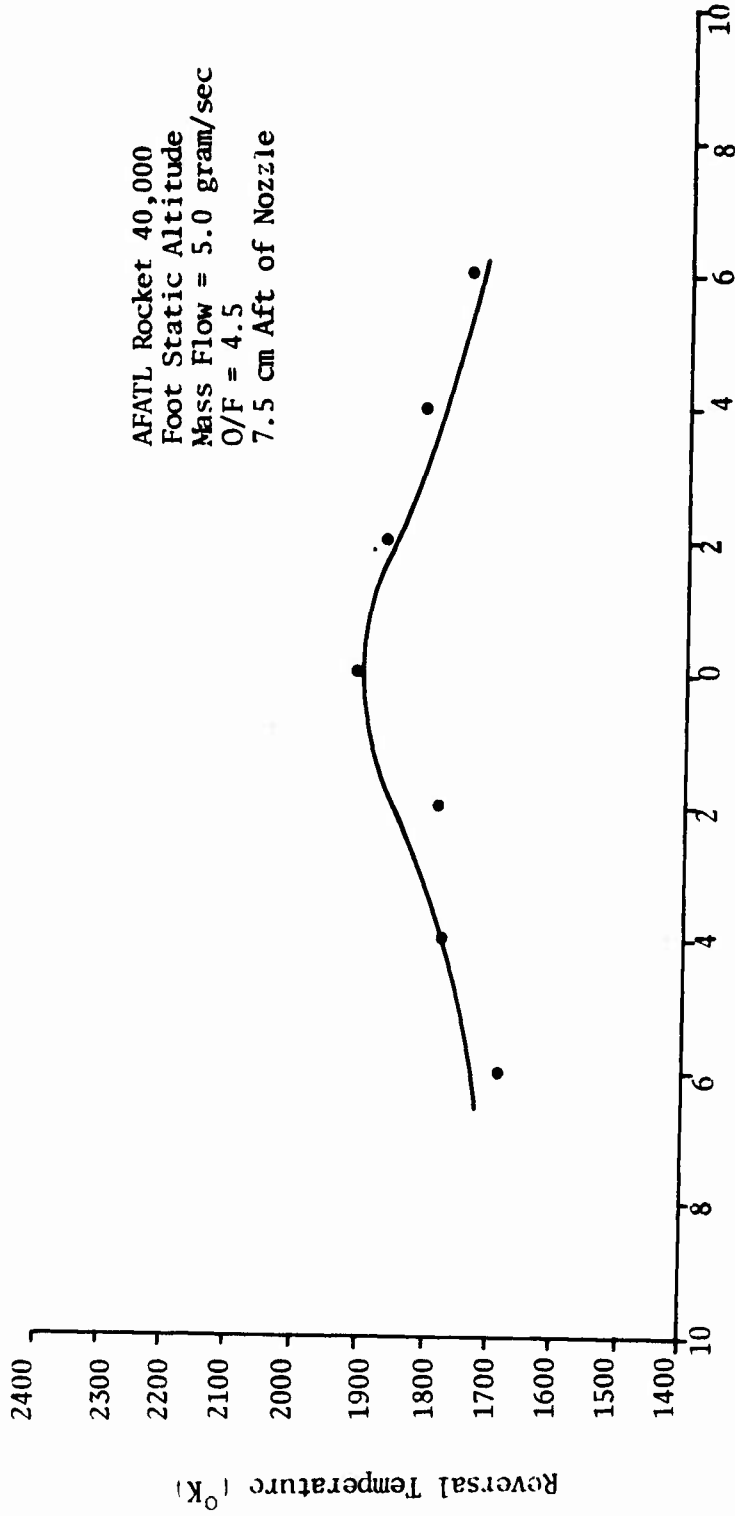

Figure C-7. Radial Temperature Scan (7.5 cm Aft of Rocket Nozzle)

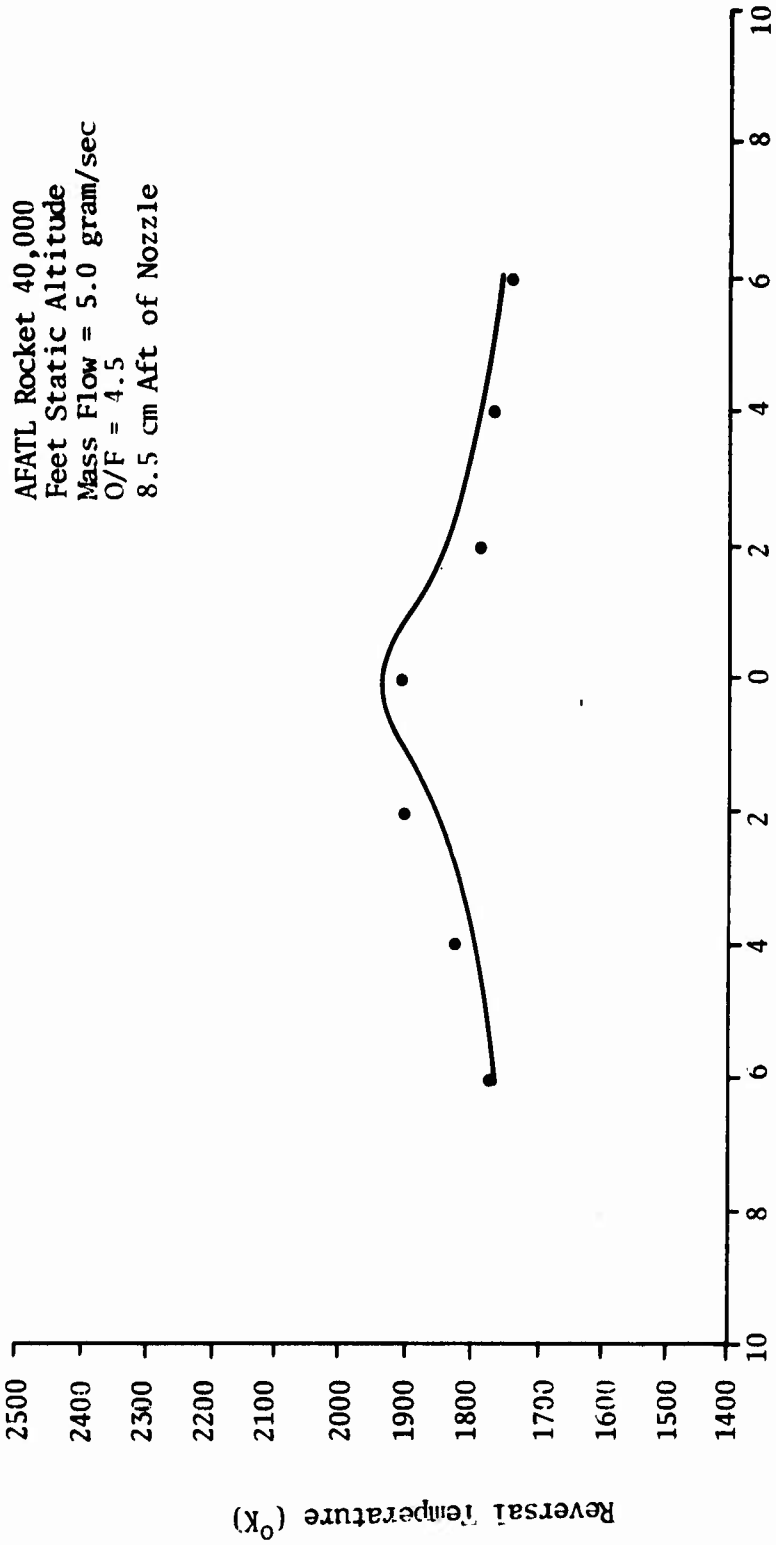

Figure C-8. Radial Temperature Scan (8.5 cm Aft of Rocket Nozzle)

AFATL Rocket 40,000
Feet Static Altitude
Mass Flow = 5.0 grams/sec
O/F = 4.5
10.0 cm Aft of Nozzle

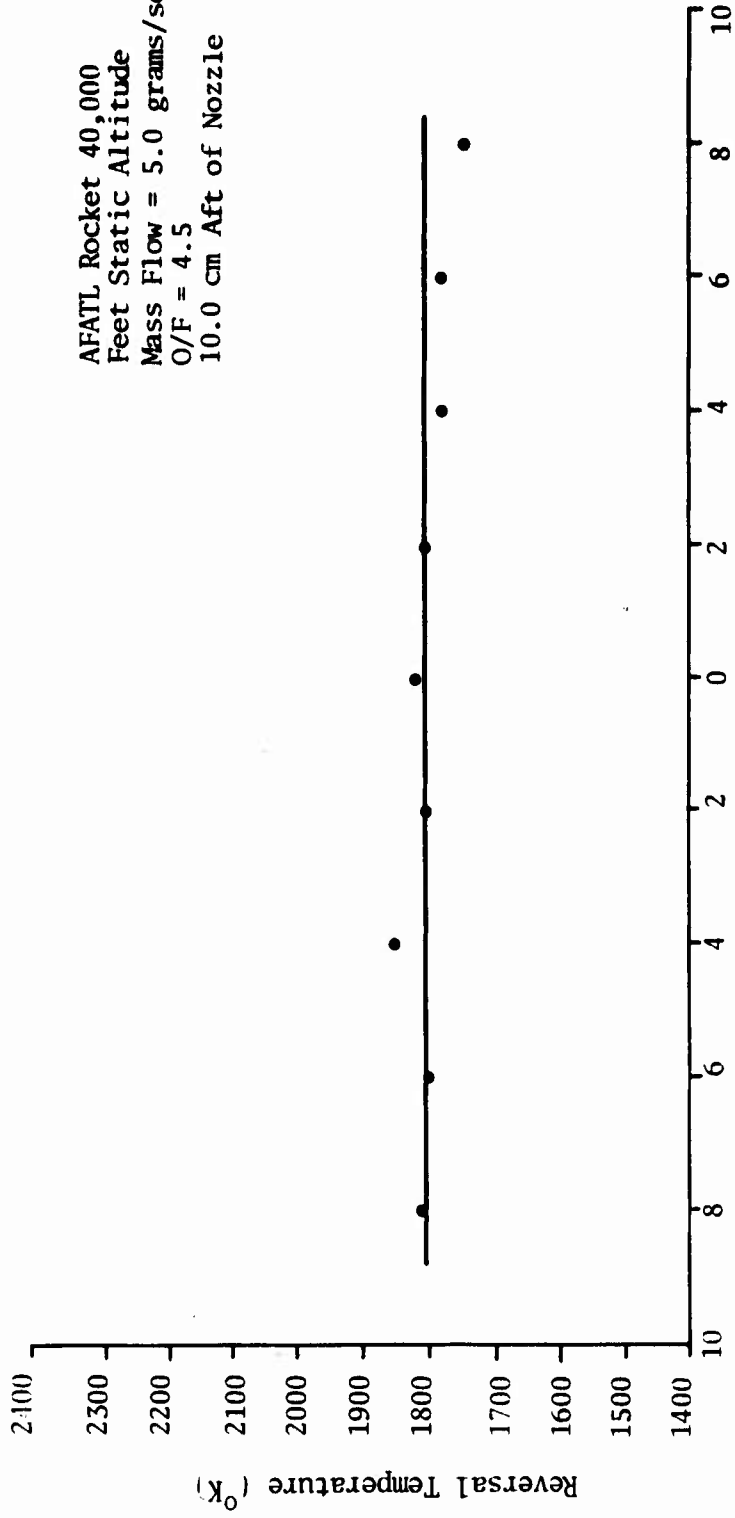

Figure C-9. Radial Temperature Scan (10.0 cm Aft of Rocket Nozzle)

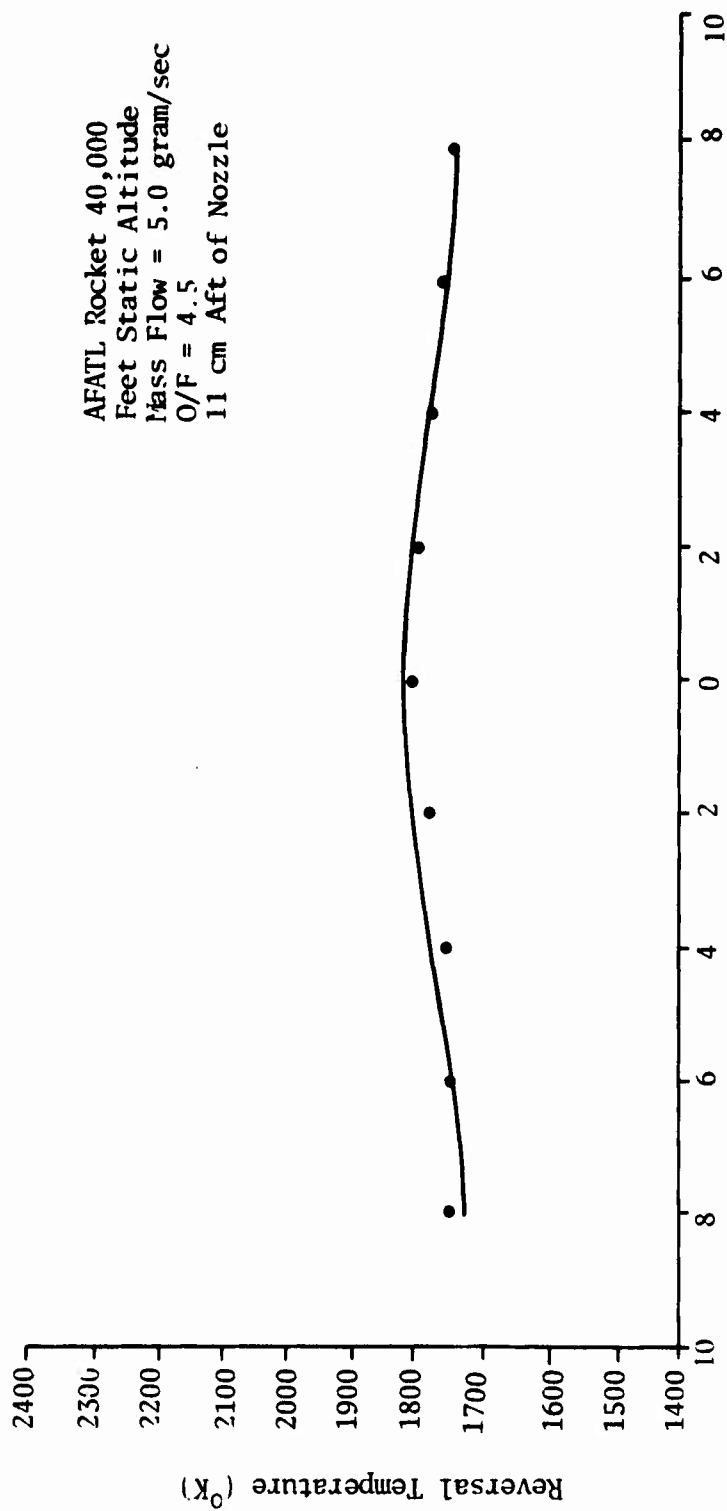

Figure C-10. Radial Temperature Scan (11 cm Aft of Rocket Nozzle)

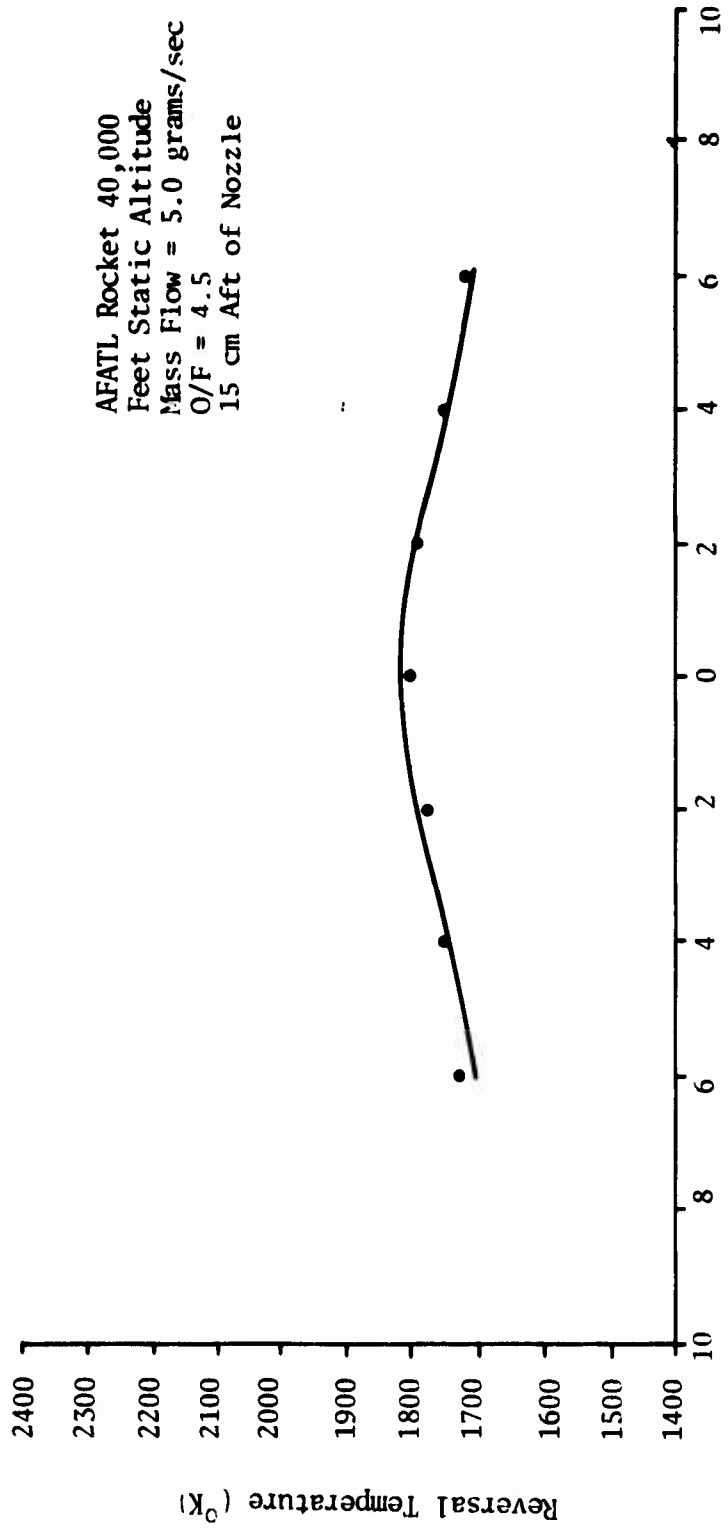

Figure C-11. Radial Temperature Scan (15 cm Aft of Rocket Nozzle)

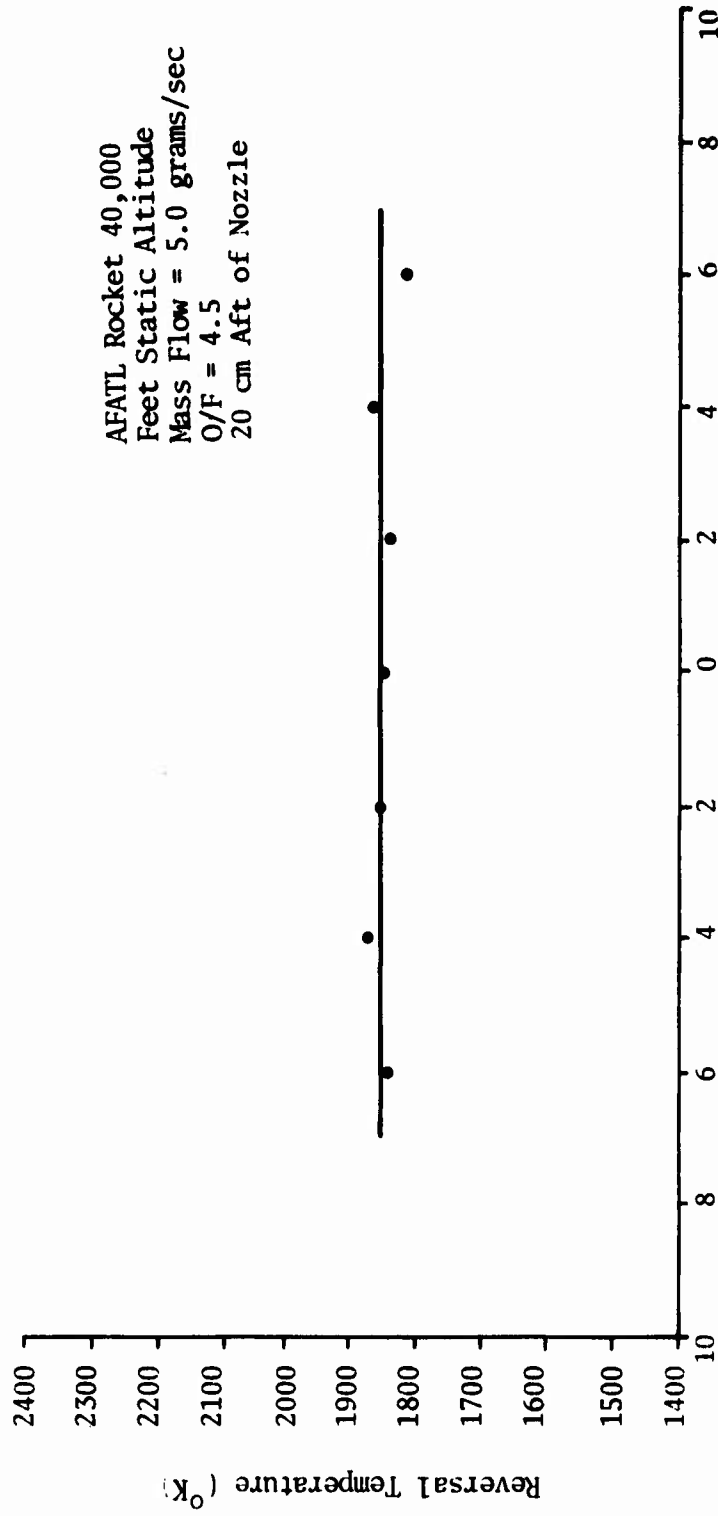

Figure C-12. Radial Temperature Scan (20 cm Aft of Rocket Nozzle)

AFATL Rocket 40,000
Feet Static Altitude
Mass Flow = 5.0 gram/sec
O/F = 4.5
25 cm Aft of Nozzle

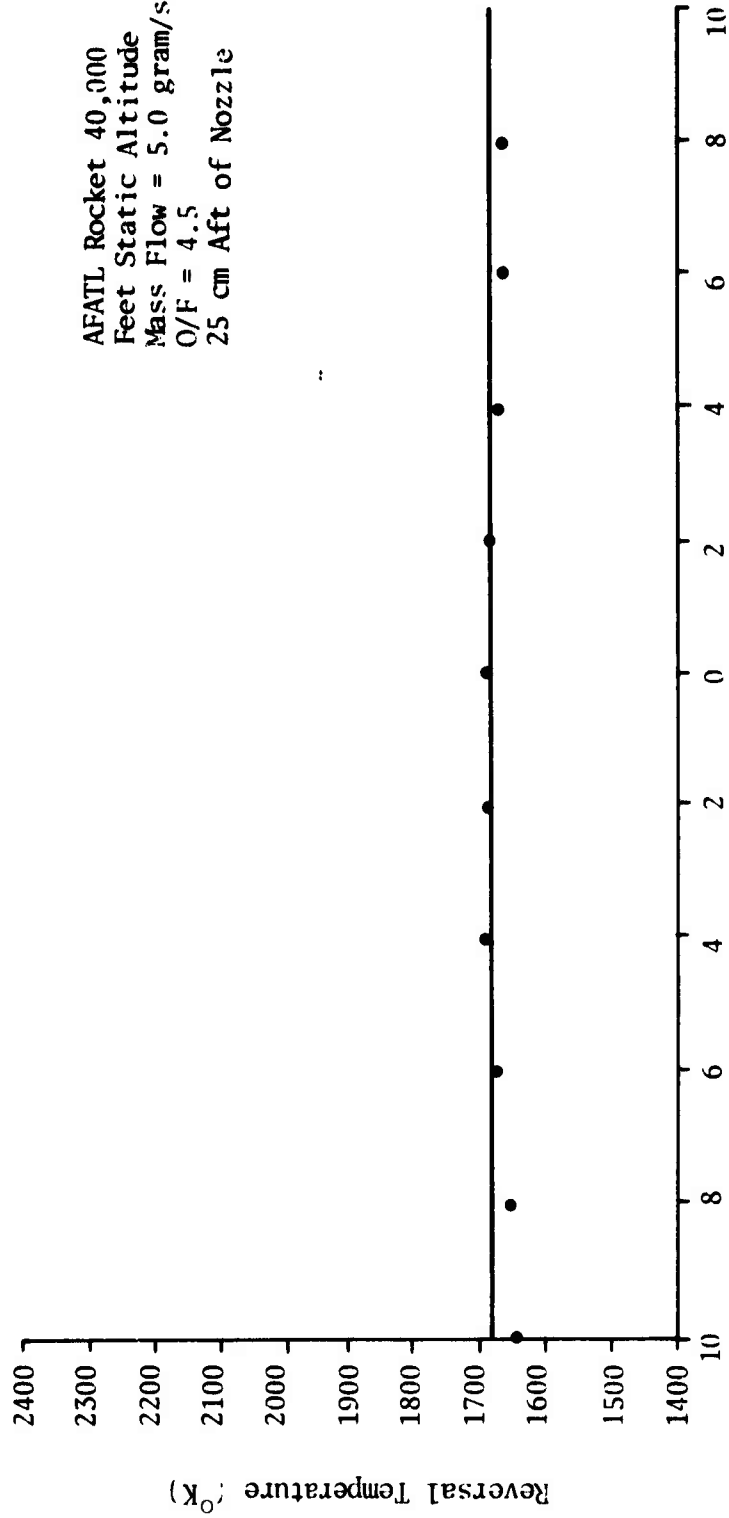

Figure C-13. Radial Temperature Scan (25 cm Aft of Rocket Nozzle)

AFATL Rocket 40,000
Feet Static Altitude
Mass Flow = 5.0 gram/sec
30.0 cm Aft of Nozzle

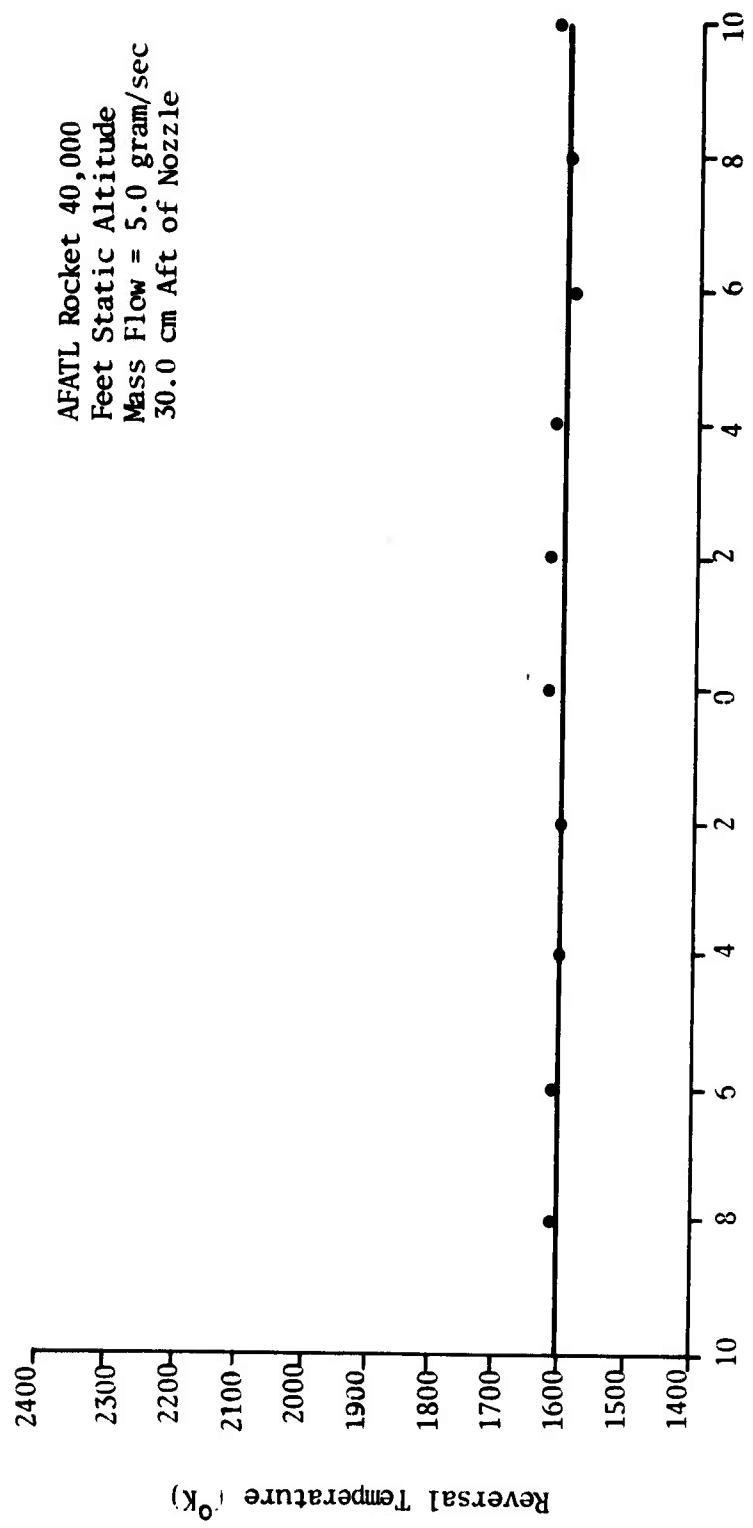

Figure C-14. Radial Temperature Scan (30.0 cm Aft of Rocket Nozzle)

INITIAL DISTRIBUTION

HQ, USAF/SAMI	1	ODDR&E/TST&E	1
HQ USAF/RDPA	1	DARPA/TIO	1
HQ USAF/RDQRM	1	NAVAIR SYS COMD	1
HQ USAF/XOOPA	1	USAF/AFSC LIASON OFFICE	6
AFSC/INA	1	COMMANDER NWC/CODE 456	2
AFSC/SDA	1	COMMANDER NWC/CODE 533	1
AFSC/DLCAW	1	COMMANDER NWC/CODE 4063	1
AFIS/INT	1	COMMANDER NWC/CODE 40903	3
AFSC/DPSL	1	COMMANDER NWC/CODE 3301	1
AFSC/SDWM	1	COMMANDER NWC/CODE 335	1
TAC/DRA	2	REDSTONE SCI INFO GEN	3
TAC/XPSY	1	USN WEAPONS LAB (MAL)	1
AFAL/AA	1	CG USAMI COM	1
AFAL/TEM	1	DDC-TC	2
AFAL/RWM	1	CINCPACAF/IGFW	1
AFAL/RW	3	ADTC/PP	1
ASD/YHEV	1	ADTC/TE	1
ASD/XRG	2	ADTC/XR	2
ASD/YFEI (ARMAMENT)	1	SOP/DR	1
ASD/ENO	1	TAWC/ERW	1
ASD/ENYW	1	TAWC/TX	1
ASD/ENASA	1	AFATL/DL	1
ASD/YPEX	1	AFATL/DLB	1
ASD/RWS	11	AFATL/DLMI	5
ASD/RWR	2	AFATL/DLMM	1
ASD/ENFEA	1	AFATL/DLOU	1
ASD/SD (TECH DIR)	1	AFATL/DLY	2
ASD/SD7	2	AFATL/DLYA	1
ASD/SD5EI	1	AFATL/DLYW	1
ASD/SD4T	2	AFATL/DLJ	1
AFFDL/FE	1	AFATL/DLJF	1
AFFDL/FGL	1	AFATL/DLJC	1
AFFDL/FX	1	AFATL/DLJA	1
AFFDL/FY	1	AFATL/DLODL	2
AFML/MX	1	ADTC/SD	1
AFML/LL	1	ADTC/SDM	1
AFML/MB	1	ADTC/SDE	3
AFML/LP	1	ADTC/SD7	3
AFLC/MMWM	1	ASD/SDO	1
OO-ALC/MMWMP	2	ASD/SDM	1
6585 TG/GDP	1	AFFDL/FGC	1
AUL/LSE 71-249	1	AFML/LPO	1
ATC/XPOS	1	USAF ACADEMY	1
NAV AIR SYSTEMS COMD/AIR-5323	1	SAC/XHIN	2
NAV AIR SYSTEMS COMD/AIR-5324	1	SAC/DOXT	1

SAC/LGWC	1
AFAL/NVA-679A	2
ASD/SD-65	1
TAWC/TXA	1
PHILCO-FORD	1
ROCKWELL INTERNATIONAL	1
HUGHES AIRCRAFT CO.	1
MARTIN-MARIETTA	1
RAND CORPORATION	1
AFRPL/MK	1
GENERAL DYNAMICS	1
TAC/INAT	1
ASD/XRP	1
HQ USAFE/DOQ	1
USA TRADOC SYS ANALYS ACTVY	1
HQ PACAF/DOOFQ	3
COMIPAC/I-232	1
ASD/ENESS	1