

UNCLASSIFIED

AD NUMBER

ADB027957

LIMITATION CHANGES

TO:

Approved for public release; distribution is unlimited.

FROM:

Distribution authorized to U.S. Gov't. agencies only; Test and Evaluation; DEC 1977. Other requests shall be referred to Air Force Armament Lab., Eglin AFB, FL.

AUTHORITY

AFATL ltr 28 Jan 1981

THIS PAGE IS UNCLASSIFIED

**THIS REPORT HAS BEEN DELIMITED
AND CLEARED FOR PUBLIC RELEASE
UNDER DOD DIRECTIVE 5200.20 AND
NO RESTRICTIONS ARE IMPOSED UPON
ITS USE AND DISCLOSURE.**

DISTRIBUTION STATEMENT A

**APPROVED FOR PUBLIC RELEASE,
DISTRIBUTION UNLIMITED.**

FOR FURTHER TRAN

②

AFATL-TR-77-136

Instrumentation Development to Measure Camoflet Size

ORLANDO TECHNOLOGY, INC
ORLANDO, FLORIDA 32810

DECEMBER 1977

FINAL REPORT FOR PERIOD AUGUST 1977-SEPTEMBER 1977

Distribution limited to U.S. Government agencies only; this report documents test and evaluation; distribution limitation applied December 1977. Other requests for this document must be referred to the Air Force Armament Laboratory (DLYV), Eglin Air Force Base, Florida 32542.

DDC
JUN 22 1978
RECEIVED
F



Air Force Armament Laboratory
AIR FORCE SYSTEMS COMMAND * UNITED STATES AIR FORCE * EGLIN AIR FORCE BASE, FLORIDA

78 06 20 032

AD B027957

DDC FILE COPY

UNCLASSIFIED

SECURITY CLASSIFICATION OF THIS PAGE (When Data Entered)

REPORT DOCUMENTATION PAGE		READ INSTRUCTIONS BEFORE COMPLETING FORM
1. REPORT NUMBER 18 AFATL-TR-77-136	2. GOVT ACCESSION NO. 9 Final rept. Aug-Sep 77	3. REPORT NUMBER
4. TITLE (and Subtitle) 6 INSTRUMENTATION DEVELOPMENT TO MEASURE CAMOFLET SIZE,	5. TYPE OF REPORT & PERIOD COVERED Final August 1977 through Sept 1977	6. PERFORMING ORG. REPORT NUMBER
7. AUTHOR(s) Hans R. Fueher John W. Keeser, Jr.	8. CONTRACT OR GRANT NUMBER(s) 15 F08635-77-C-0073	
9. PERFORMING ORGANIZATION NAME AND ADDRESS Orlando Technology, Inc. 6237 Edgewater Drive Orlando, FL 32810	10. PROGRAM ELEMENT, PROJECT, TASK AREA & WORK UNIT NUMBER Program Element 62602F JON 2549-02-26	
11. CONTROLLING OFFICE NAME AND ADDRESS Air Force Armament Laboratory Armament Development and Test Center Eglin Air Force Base, Florida 32542	12. REPORT DATE 11 December 1977	13. NUMBER OF PAGES 12 30p.
14. MONITORING AGENCY NAME & ADDRESS (if different from Controlling Office)	15. SECURITY CLASS. (of this report) UNCLASSIFIED	15a. DECLASSIFICATION/DOWNGRADING SCHEDULE
16. DISTRIBUTION STATEMENT (of this Report) Distribution limited to U. S. Government agencies only; this report documents test and evaluation; distribution limitation applied December 1977. Other requests for this document must be referred to the Air Force Armament Laboratory (DLYV), Eglin Air Force Base, Florida 32542.		
17. DISTRIBUTION STATEMENT (of the abstract entered in Block 20, if different from Report)		
18. SUPPLEMENTARY NOTES Available in DDC		
19. KEY WORDS (Continue on reverse side if necessary and identify by block number) Camoflet Ionization Trigger Points Ionization Probe Schmitt Trigger		
20. ABSTRACT (Continue on reverse side if necessary and identify by block number) This report summarizes results of 2 months of design and testing. The objective was to develop instrumentation capable of recording the time dependent growth of the camoflet produced by a buried explosive charge by using the conductive properties of an ionized gas. The initial instrument consisted of a heavy steel pipe probe containing evenly spaced twisted wire-pairs. Each twisted wire-pair led to an electronic logic circuit which changed state		

DD FORM 1473
1 JAN 73

EDITION OF 1 NOV 65 IS OBSOLETE

UNCLASSIFIED

391064 SECURITY CLASSIFICATION OF THIS PAGE (When Data Entered)

CL

UNCLASSIFIED

SECURITY CLASSIFICATION OF THIS PAGE(When Data Entered)

when ionized gas completed the electrical circuit through the ends of the twisted wires. An oscilloscope recorded the series of waves produced by completing the circuit through several spaced wire-pairs by the expanding ionized gaseous explosive detonation products. Test results indicated that the ionization concept is valid for this application, but the electronic logic system used should be hardened to withstand higher shock pressures. More meaningful results may also be obtained by use of three or more probes per test since the camoflet did not seem to be symmetric. Another system of detection, such as a photo-transistor light detector, may add additional reliability to the system and is recommended for investigation. This system would use the light from the incandescent gaseous detonation products to measure the camoflet expansion rate.



UNCLASSIFIED

SECURITY CLASSIFICATION OF THIS PAGE(When Data Entered)

PREFACE

This report summarizes experimentation and analysis conducted from August through September 1977 by Orlando Technology, Inc., 6237 Edgewater Drive, Orlando, Florida 32810 under Contract F08635-77-C-0073 with the Air Force Armament Laboratory, Armament Development and Test Center, Eglin Air Force Base, Florida 32542. Mr. G. Rickey Griner (DLYV) served as program manager for the Armament Laboratory.

Orlando Technology, Inc. principal investigators were Dr. Hans R. Fuehrer and Mr. John W. Keeser, Jr. Mr. Jerry H. Ross (TEEPF) designed the electronics system used during the program.

This technical report has been reviewed and is approved for publication.

FOR THE COMMANDER:

J. R. Murray
Chief, Analysis Division

TABLE OF CONTENTS

Section	Title	Page
I	INTRODUCTION.....	1
	A. Objective.....	1
	B. Background.....	1
	C. Program Approach.....	1
	D. Achievements.....	2
	E. Recommendations.....	2
II	IONIZATION PROBE CHARACTERISTICS.....	3
	A. Probe Design.....	3
	B. Mechanical Design.....	3
	C. Electrical Design.....	10
III	EXPERIMENTAL TEST RESULTS.....	12
	A. Test Setup.....	12
	B. Test Results.....	12
IV	CONCLUSIONS AND RECOMMENDATIONS.....	20
V	NEW TEST SYSTEM.....	22
	REFERENCES.....	24

LIST OF FIGURES

Figure	Title	Page
1.	Ionization Probe Body.....	4
2.	Detachable Nose Section.....	5
3.	Massive Base Ring.....	6
4.	Close-up of Ionization Switch Probe.....	7
5.	Complete Probe/Electronics Assembly.....	8
6.	Final Feed-Through for Ionization Lead.....	9
7.	Final Ionization Wire Configuration.....	9
8.	Typical Logic Circuit for Two Ionization Switches.....	11
9.	Test Setup Prior to Backfill.....	13
10.	Test Setup-Mechanical and Electrical.....	14
11.	Oscillograph for Test Number 5.....	15
12.	Oscillograph for Test Number 7.....	17
13.	Test Results for a 27-Pound Buried Charge (Test Number 8).	17
14.	Burned Area on Probe-27 Pounds of C4 in Soil (Test Number 10.....	18
15.	Test Results-27 Pounds C4 in Soil (Test Number 11).....	19
16.	Modified Ionization Probe Tip.....	21
17.	Proposed Test Setup.....	23

SECTION I
INTRODUCTION

A. OBJECTIVE

The objective of this program was to develop a practical system for measuring the maximum size and growth rate of the camoflet produced when an explosive charge is detonated underground.

B. BACKGROUND

Earlier work on the standoff distance required to breach a hardened structure using buried explosive charges (Reference 1) indicated that physical contact of the camoflet with the target was desirable and/or necessary to obtain maximum efficiency from the explosive.

The size of the camoflet produced by a given amount of buried explosive is determined by soil characteristics and other parameters. When determining the behavior of soils under the influence of an exploding high explosive charge, accurate data on the detonation product expansion is necessary. Many techniques have been deployed including those of solving the continuum mechanics equation in finite difference forms. This method allows the expanding products to act against the surrounding soil causing stress waves to be generated in that media.

It is well known that the detonation products are highly conductive as a result of ionization occurring within the products themselves. Techniques for measuring detonation fronts in explosives employ this feature to determine the rate at which the detonation wave travels through the explosive (Reference 2). The ionized property of gaseous detonation products has also been used as a trigger to indicate when the detonation occurs so that subsequent events can be recorded in relationship to that starting time. The ionized property of detonation products in air have been used to determine the expansion history of the gases.

C. PROGRAM APPROACH

The basic approach was to measure the ionized detonation products and apply the data to measure camoflet growth rate. Effort was directed toward design and development of a time dependent ionization switch triggered by the detonation products.

An ionization switch in the explosive charge has been used to trigger oscilloscope traces for previous underground work. The simplest form of the switch was two insulated wires twisted together and clipped. A voltage was applied across the wires and when a conductive ionization path was established, the ΔV across a resistor provided the oscilloscope trigger. This switch technique does not lend itself to repetitive pulsing, and further, has poor edge response because of cable capacitance.

A solid state circuit was developed using Schmitt triggers (one per switch) as inputs into operational amplifiers connected as summers, then into a monostable multivibrator (one shot). The one shot had an output pulse width of 50 microseconds at 3.5 volts when driving 250 feet of RG58U cable.

Each time a Schmitt trigger is shorted, a square wave pulse is produced. The distance between the leading edges of a train of pulses can be converted to camoflet front velocity. Two duplicate circuits were used in the system for redundancy and increased reliability.

D. ACHIEVEMENTS

Following the preceding approach, a probe/logic system was designed and built. Limited testing of the system in air indicated a need for better shock mounting of the logic boards and improved electrical isolation of the active probe elements from the probe body. Of six tests conducted, only two gave positive results. Indicated changes were made to the system and underground testing commenced.

Detonating 8 pounds of C4 buried 5 feet deep gave two trigger points, indicating ionization radius of 9 to 12 inches. Subsequent visual inspection of the probe showed burned areas extending to 14 inches but not in line with trigger wire.

Four attempts to measure the camoflet produced by 27 pounds of C4, buried 10 feet deep, gave inconclusive results. These were caused by ground water and circuit failure. Visual post-test examination of the probe and surrounding soil indicated a maximum camoflet radius of 35 to 38 inches.

E. RECOMMENDATIONS

It is recommended that several changes be made to the system to improve reliability and accuracy. The ionization probe should be redesigned to incorporate both optical and thermal sensing systems in addition to the ionization systems. The logic circuit should be further isolated from both electrical and mechanical pulses. Several possible approaches are presented in Section IV.

SECTION II

IONIZATION PROBE CHARACTERISTICS

A. PROBE DESIGN

The initial ionization probe concept was to use a massive steel bar with the trigger wire sets inside and terminating at spaced points along its surface. The massive design was necessary to preclude motion prior to the arrival of the camoflet and also to allow for possible reuse. The inside was hollow to allow for internal placement of the trigger wires. The probe design is broken into two areas for discussion: mechanical and electrical.

B. MECHANICAL DESIGN

Figures 1 through 5 show all phases of the steel probe including the ionization wire sets. The basic probe body (Figure 1) was machined from a length of 1-inch wall by 4-inch O.D. mechanical steel tubing. A hardened steel nose piece (Figure 2) was threaded on the front end. This nose piece was replaceable in case of damage and also for ease of installing the ionization wire sets. The wire sets were also replaceable as required. The body of the probe was inserted into a base ring (Figure 3). This base gave additional massive restraint to the probe. Figure 1 shows the assembly details for the internal wiring, while Figure 4 shows a close-up of the probe wires. Figure 5 is a complete assembly.

Initial testing with explosives revealed several necessary changes to the probe body. The orientation and size of the feed-through holes was changed to allow easier wire feed. Figure 6 details this new configuration. The trigger wire end was also modified per Figure 7 to allow for easier assembly. The center conductor was twisted together and tinned, then cut to a length of 0.05 inch. The ground shield was then brought radially up to, but not touching, (≈ 0.02 inch away) the center conductor. The shield wires were then soldered together to form a ring around the center conductor. This procedure gave a rigid ring of ground shield evenly spaced around the center conductor. The air gap was adjusted to 0.01 to 0.02 inch. A 2-inch length of plastic tubing was then fitted over the cable end for abrasion resistance. RTV was used to hold the gage assembly in place in the pipe.

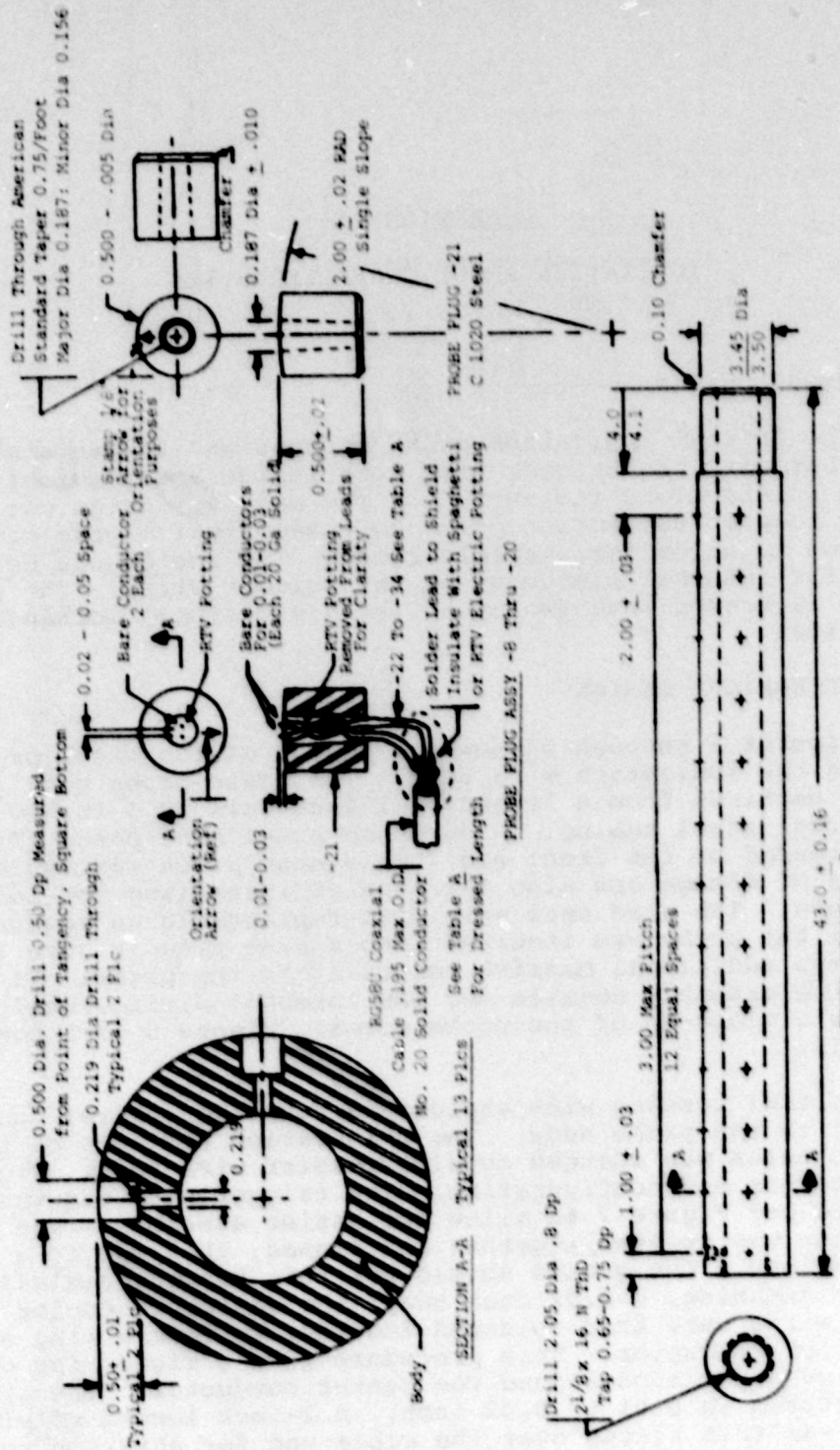

All Dimensions in Inches

Figure 1. Ionization Probe Body

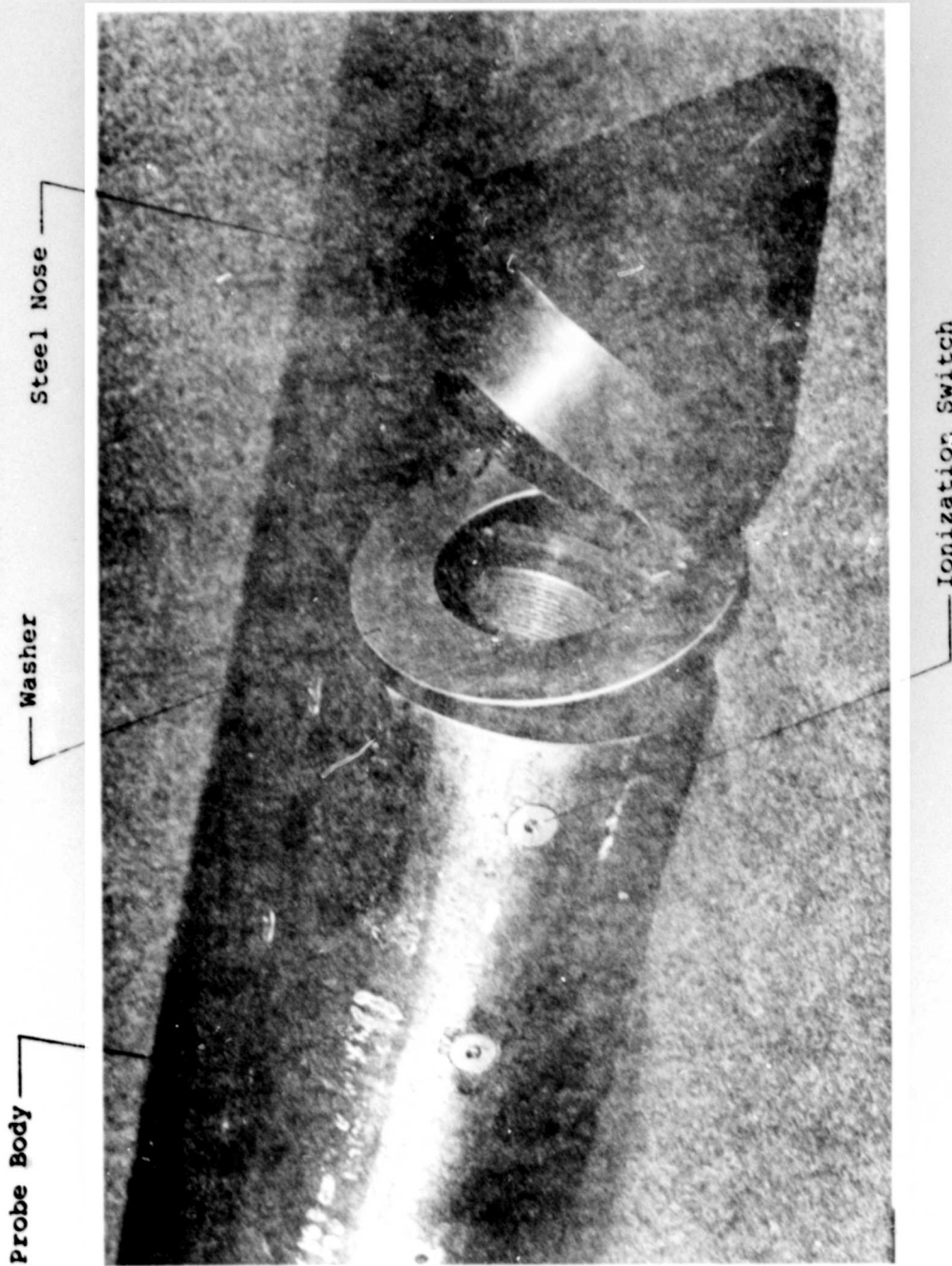
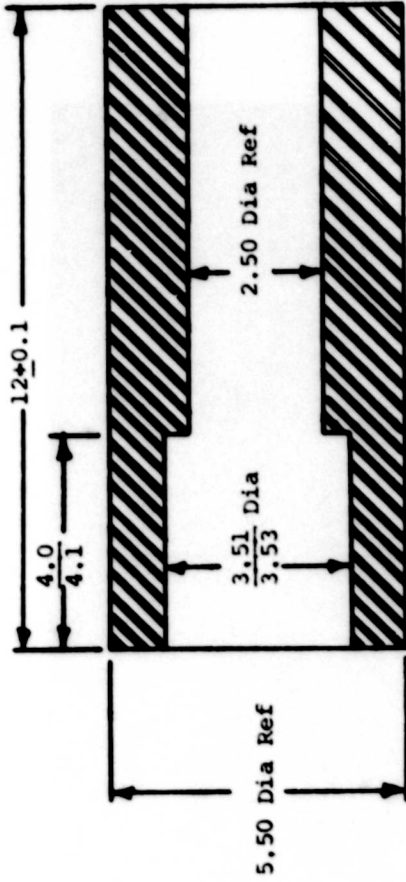
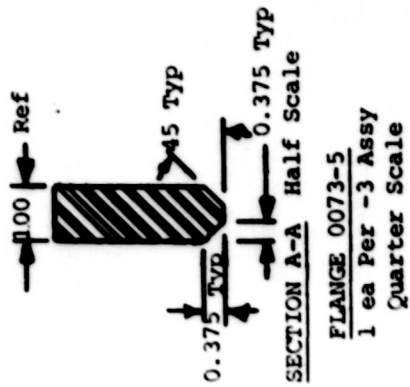
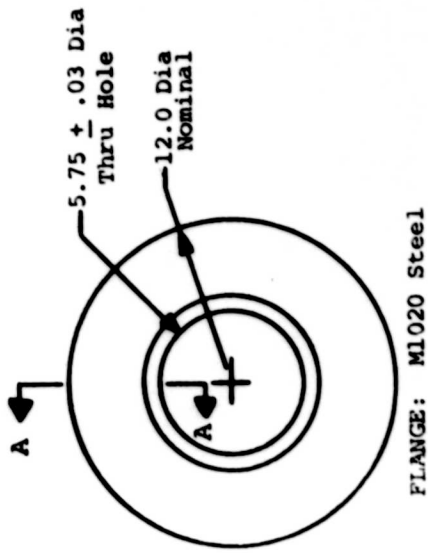
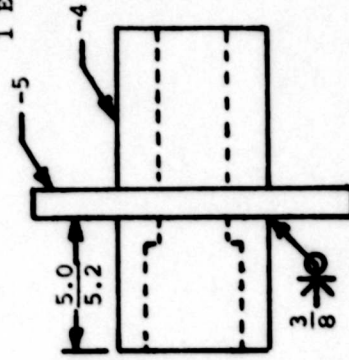

Figure 2. Detachable Nose Section



BASE PIPE Matl: 5.5 ODX2.5 ID Mechanical Steel Tubing: Hot Rolled, Low Carbon

0073-4
1 Each Per -3 Assy Half Scale



BASE ASSY 0073-3

NOTES

1. All Dimensions in Inches
2. Remove all Burs & Sharp Edges

Figure 3. Massive Base Ring

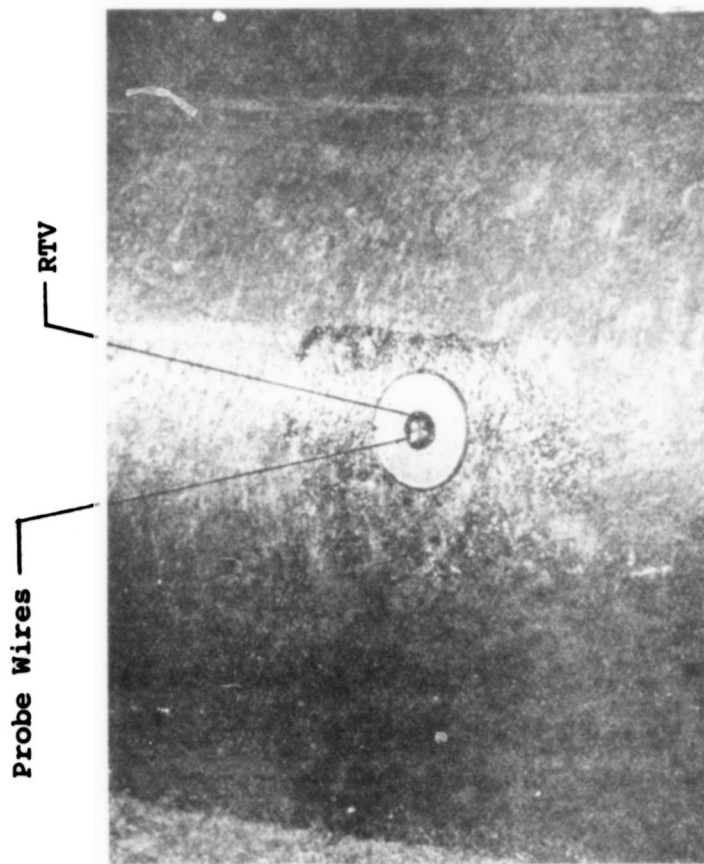

Figure 4. Close-up of Ionization Switch on Probe

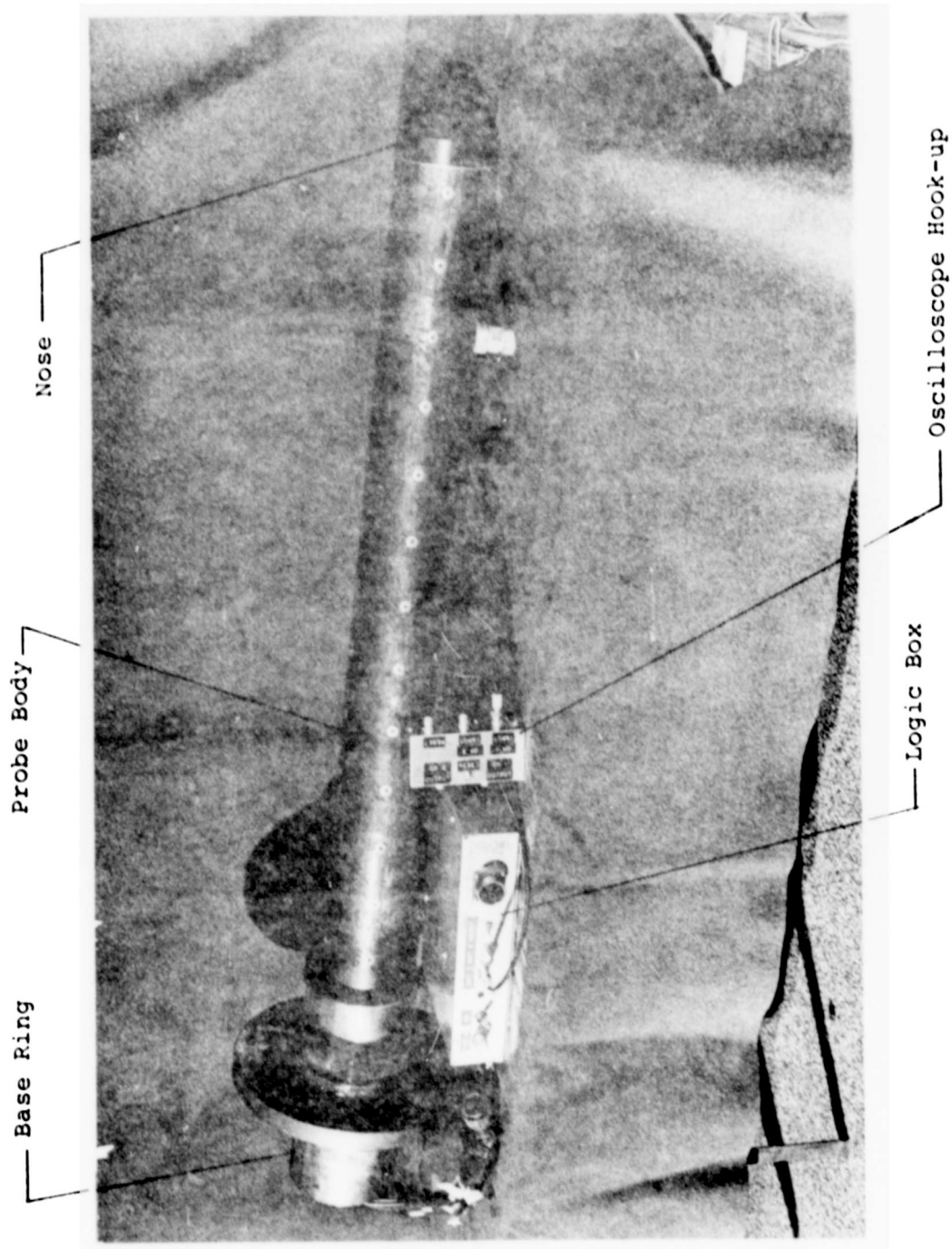

Figure 5. Complete Probe/Electronics Assembly

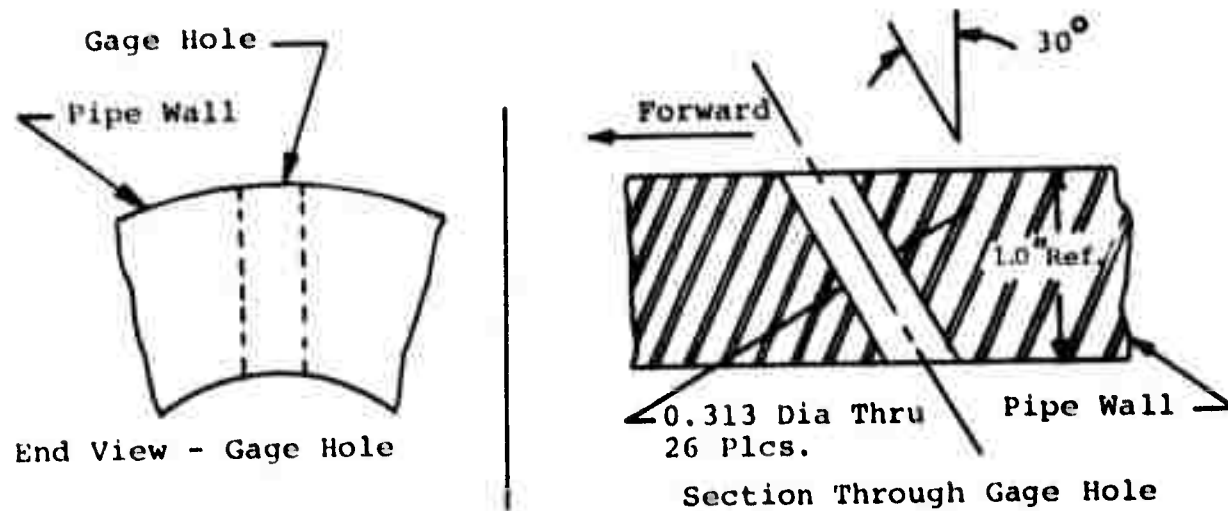

Figure 6. Final Feed-Through for Ionization Lead

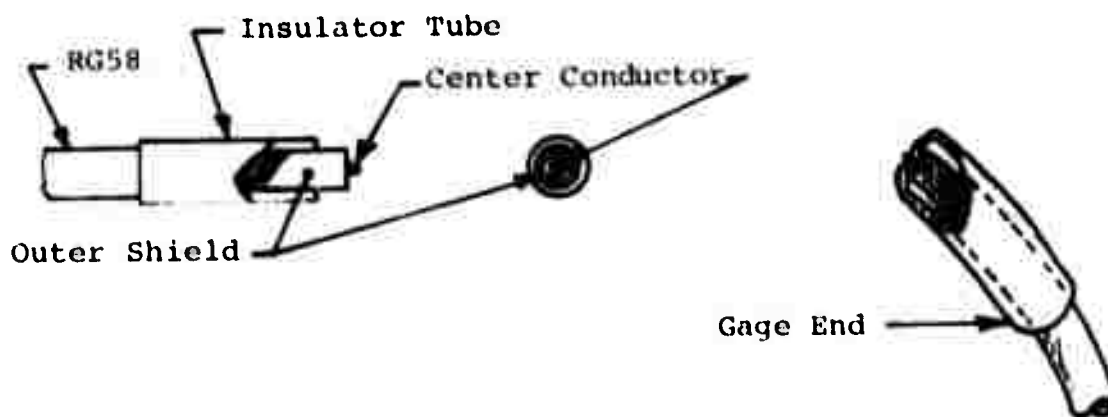

Figure 7. Final Ionization Wire Configuration

C. ELECTRICAL DESIGN

The electrical systems for the probe had to satisfy several criteria:

- 1 Fast response time (1 to 5 microseconds rise time);
- 2 High noise tolerance;
- 3 Square wave pulses, one per trigger; and
- 4 Shock tolerance.

A solid-state logic circuit using Schmitt triggers driving a one-shot through a summing amplifier was used to get the square wave output. Figure 8 shows the logic circuit. The values of R and C were initially set to give a 50 microsecond pulse width. The initial design had 16 Schmitt/ionization points per circuit with 2 circuits per probe for redundancy. A reset button was incorporated so that all the triggers could be reset to the ground state just prior to detonation.

A regulated power supply was built into the logic circuit box for field operation. All components were mounted on a wire-wrapped board using DIP sockets.

Initial field testing revealed that this system would not withstand heavy shock loads, as the chips fell out of the circuit board. A slab of foam was placed between the chips and box cover as a quick-fix to correct this. Future systems would be encapsulated after final check and verifications.

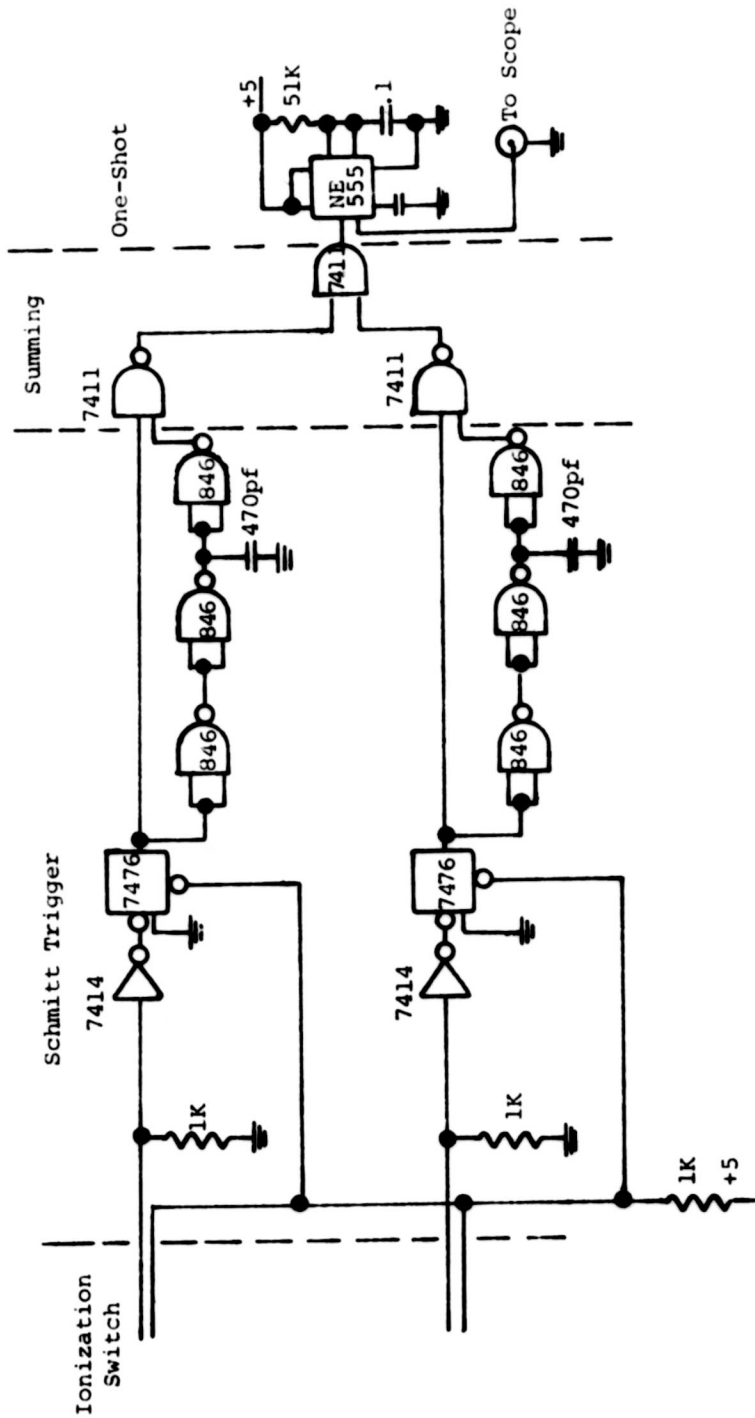

Figure 8. Typical Logic Circuit for Two Ionization Switches

SECTION III

EXPERIMENTAL TEST RESULTS

Eleven attempts were made to get the maximum camoflet size using the ionization probe. Mixed results ranging from no-trace to multiple triggers were obtained.

Six tests were conducted using 1 pound of Composition C4 in air. Only two definite triggers were obtained. The other four tests gave either no trace or ambiguous readings.

One test was conducted using 8 pounds of C4. Both the probe and C4 were buried 5 feet deep. Two trigger points were ionized. This indicated a radius of from 9 to 12 inches for the ionized gas ball.

Four tests were run using 27 pounds of C4 buried 10 feet deep. No clear trigger sequence was obtained; with two tests having smooth traces and two tests showing only 1 trigger ionized. The first attempt at placing a charge 10 feet deep showed that ground water would be a problem. To eliminate false triggers caused by ground water, the explosive-probe assembly was wrapped in plastic and sealed. Figure 9 shows a test set prior to backfill. Further, each trigger was tested to verify an open circuit after backfill was completed.

A. TEST SETUP

The electrical setup used for all the tests is shown in Figure 10. The explosive charge was placed either on-axis or in-line with the upper surface of the pipe (above-ground tests only). Figure 9 is a photograph of the probe/cable set emplaced prior to backfill.

B. TEST RESULTS

A discussion presenting the significant parameters and results for each probe test is contained in the following paragraphs.

Test 1: A charge of 1½ pounds C4 was positioned on axis at six inches to the first ionization point. This was an above-ground test. No oscilloscope trace was obtained. The shock wave shook the logic box apart. The box was reassembled and foam filled.

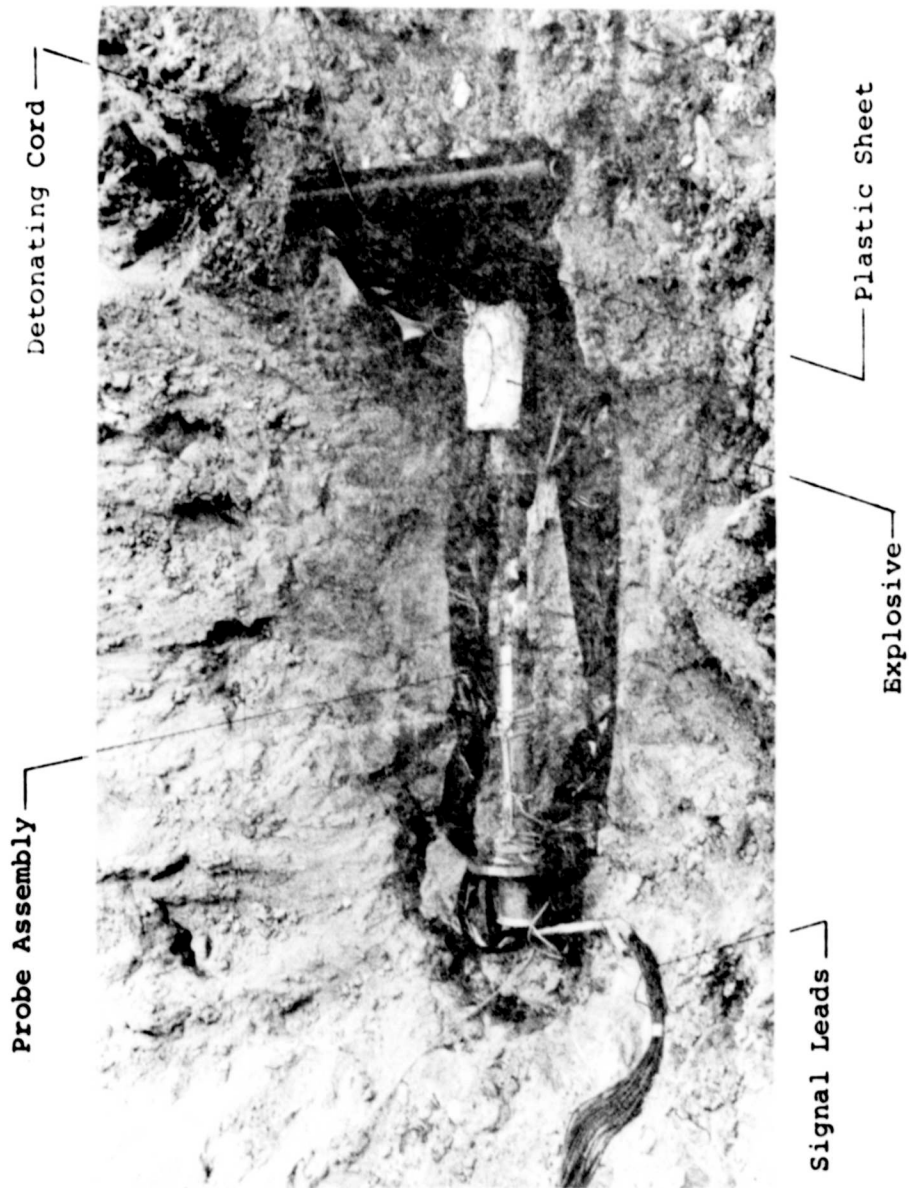

Figure 9. Test Setup Prior to Backfill

1. Trigger system connected to external trigger on scope
2. Firing line initiated by remote firing system
3. Trace photographed with scope-mounted Polaroid camera

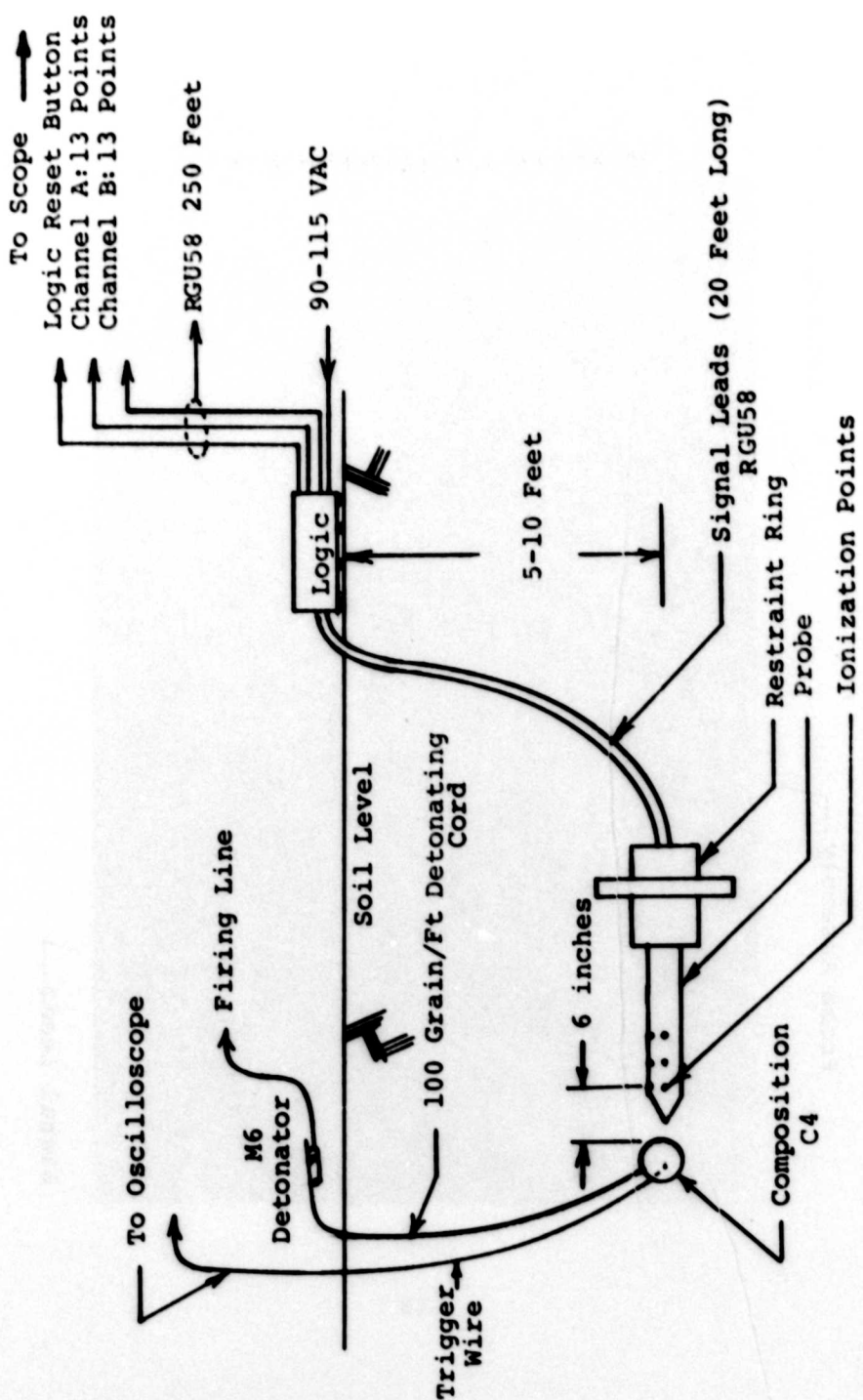

Figure 10. Test Setup-Mechanical and Electrical

Test 2: Test conditions were the same as Number 1. Both channels super-imposed on trace. No real data was obtained.

Test 3: Test conditions were the same as Number 1 except the charge was placed 30 degrees off the probe longitudinal axis and 6 inches to the nearest ionization point. Channel 2 had four apparent triggers. Channel 1 did not indicate. After this test, the probe and wires were modified as per Figure 7 to improve the ionization potential and to eliminate shorts to the steel shell of the probe body.

Test 4: Test conditions were the same as test Number 1 except the charge was placed in line with the upper surface of the probe. No usable signals were obtained.

Test 5: Test conditions were the same as test Number 4. Channel 1 gave two triggers indicating a bubble radius of 9 to 12 inches. Figure 11 is the oscillograph.

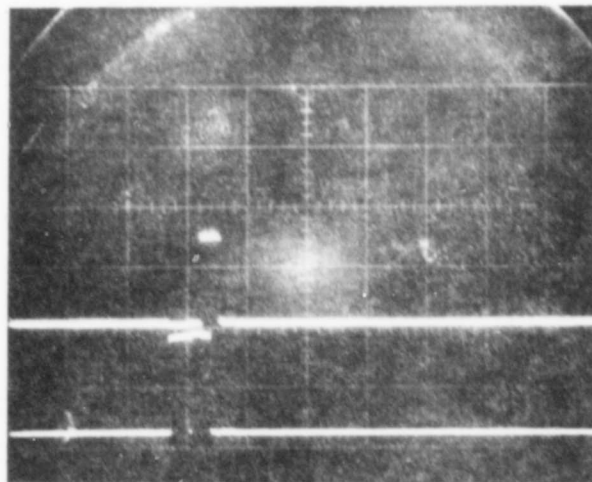

20 μ sec/cm Sweep Rate

Figure 11. Oscillograph For Test Number 5

Test 6: The charge was spherical, and 1 pound of C4 was placed in line with upper probe surface positioned 6 inches to the first ionization point. Each channel had one trigger point indicating a 6 to 9-inch radius.

Test 7: This was the first buried charge and probe test. The charge was 8 pounds of C4 at a 6-inch standoff, and was buried 5 feet deep. Channel 2 had 2 trigger points, and channel 1 had 1 trigger point. Figure 12 is an oscilloscope trace.

Test 8: The charge was 27 pounds of C4 at a 6-inch standoff. It was buried 8 feet deep. No scope data was recorded. Physical examination showed the probe to be vertical (collar down) with all of the test wires pulled out. The probe body had a 2-inch deflection near the nose. Figure 13 is a post-test photograph.

Test 9: This test was similar to Number 8 except buried 10 feet deep. One trigger point on each channel was recorded. Visual inspection of probe indicated four burned test points on each channel, or a 15 to 18-inch camoflet radius. It was felt that ground water had shorted out the test points. The remaining tests were conducted with the probe and charge wrapped in plastic to exclude water (Figure 9).

Test 10: The test conditions were the same as test Number 9. The probe and explosive were sealed in plastic. One trigger point was recorded on each channel. Visual examination showed the burned area extended past 4 points. Figure 14 shows the extent of the burned area. After test Number 10, the logic circuit was tested and found to be erratic. Pulses were sineusoidal and/or round-topped. A new logic circuit was installed and checked-out. The probe/explosive system was carefully packed in dry sand within a plastic sheet to exclude ground water. All entrance/exit points were sealed with tape. Upon completion of backfilling, each ionization point was measured for total resistance at the logic box plug. No point had less than 800 K ohms, indicating the probe was not moisture contaminated.

Test 11: Test conditions were the same as test Number 9. No trigger pulses were obtained. No logical reason could be found for the absence of trigger pulses on the oscilloscope trace. In order to gain some useful data from the test, the soil overburden was removed down to the area of the probe. Careful hand work revealed a burned ring in the sand, (Figure 15) consisting of dry pulverized sand near the probe nose and wet sand/clay near the probe base. The burn pattern on the probe was also measured and found to extend a maximum of 28.5 inches from the probe nose. Adding the clear standoff and distance to the charge gave a radius of 35.5 inches. Taking chordal measurements of the spherical burn pattern in the soil gave chord length of 44.8 inches with a maximum center height of 7.25 inches. These distances convert to a sphere with a radius of 38.25 inches. This distance was in very close agreement with the burn pattern distance.

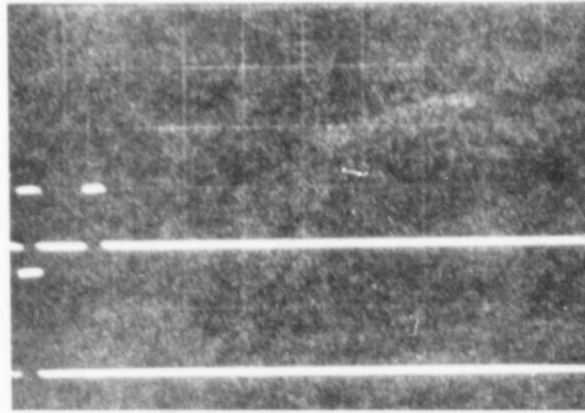

200 μ sec/cm
Sweep Rate

Figure 12. Oscillograph For Test 7



Figure 13. Test Results For a 27-Pound Buried Charge (Test 8)



Figure 14. Burned Area on Probe - 27 Pounds of C4 in Soil (Test 10)

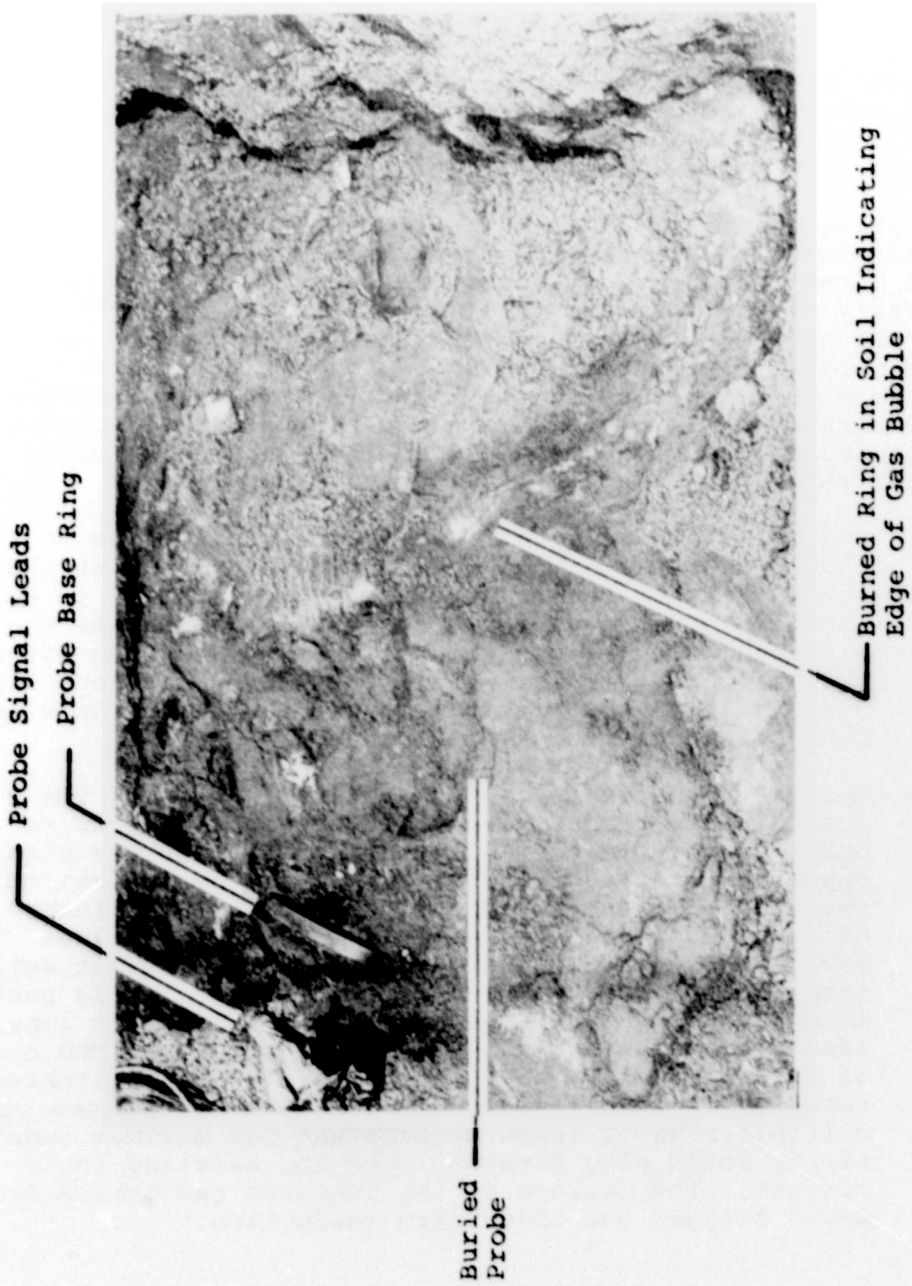

Figure 15. Test Results-27 Pounds C4 in Soil (Test 11)

SECTION IV

CONCLUSIONS AND RECOMMENDATIONS

Based on the limited success obtained during this limited program, the use of an ionization switch to determine camoflet size of a buried explosive does appear to be feasible, but the measuring system should be modified.

Physical examination of the soil surrounding the probe post-test indicated that the burned areas were very irregular having rays of burned soil extending outward from the main bubble. This was clearly shown in Figure 14. In addition, a definite physical difference in the soil in front of (near explosive) the white ring (Figure 15) was noted. This soil area was dry and more homogeneous than soil outside of the ring. It was also noticeably warmer. Taking these differences into account, it is recommended that the probe concept be modified to include the following characteristics:

1. Thermal response mode: Each probe should have several fast-response thermocouples in conjunction with the ionization switches. A response time of 0.25 to 0.50 second should be sufficient to roughly indicate the extent of the hot gas detonation products even after they collapse. This measurement cannot give any time history of the bubble, but may be useful in correlating data obtained from other sources.
2. Optical response mode: Use should be made of the incandescent properties of the gaseous products to determine camoflet size. The probe should use evenly spaced photo transistors in place of the ionization switches. Texas Instruments type LS400 NPN Planar Silicone Phototransistors are a promising choice. This device presents an open circuit in the dark but switches into conduction at ambient light levels. It is packaged in a glass rod 0.085-inch diameter by 0.6-inch long; ideal for mounting in a probe. It operates into a load of 1000 ohms at voltages of up to 30 Vdc. Switching speed at this voltage is 8 microseconds. A probe with multiple rows of these devices set for maximum sensitivity could plug directly into the existing logic circuit. The passage of the luminous gas bubble front would trigger the LS400 into conduction.

3. Ionization response mode; The ionization mode is a viable measuring technique which appears to lack sensitivity in the switch area. It is recommended that a circular switch be used similar to that shown in Figure 7. Improvement in reliability can be obtained by using a cup-shaped washer soldered over the braid with a central hole only 0.01 to 0.015 inch diameter larger than the center conductor. A spacer insulator might be used to maintain gap concentricity. Figure 16 shows the concept.

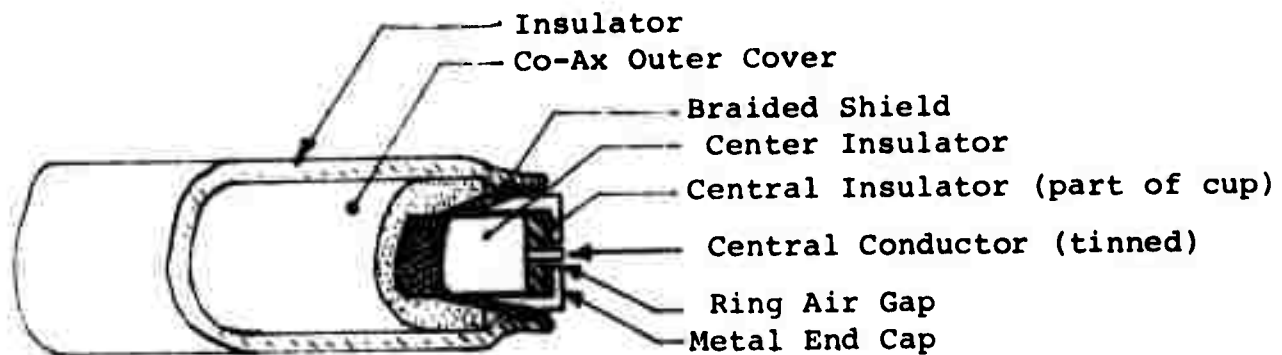

Figure 16. Modified Ionization Probe Tip

SECTION V

NEW TEST SYSTEM

The second series of development tests conducted in future work should incorporate all three of the recommended techniques in Section IV. At least three separate probes should also be used, spaced 120 degrees apart on a common horizontal plane with the explosive. All probes used should be multiple response-mode, i.e., optical/ionization/heat to insure data reliability. Figure 17 illustrates the suggested test setup.

It is further recommended that the probe assembly be mounted in a massive concrete block to maintain orientation during detonation and subsequent soil motion. The probe turn-around time could be significantly improved if a pre-cast sensor unit was designed to be locked into a probe, then removed after testing. The unit, with its cast-in-place sensors could be easily checked out and replaced if necessary. The sensor sets would be placed in position in a channel section, then the section would be filled with a rubber base casting resin.

This assembly could then be placed on, or in, a rigid steel bar for the actual test.

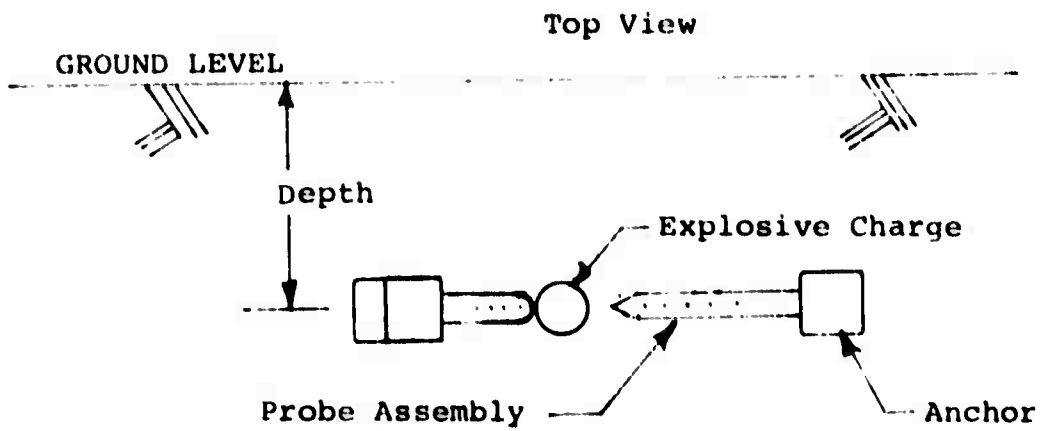
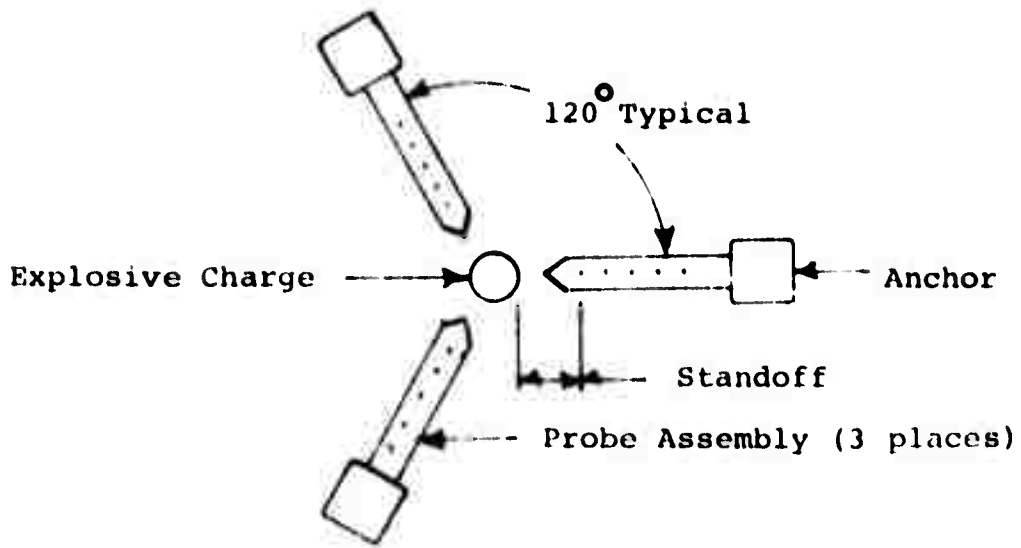

Figure 17. Proposed Test Setup

REFERENCES

1. Fuehrer, H. R. and Keeser, J. W., Investigation of Oblique Shocks and Edge Effects For Underground Targets, Volume II Edge Effects, AFATL-TR-77-1, Volume II, Air Force Armament Laboratory, January 1977, Unclassified.
2. Fuehrer, H. R. and Emmons, D. L., Multichannel Electronic Counter Chronograph for Determining Detonation Velocity in Explosives, Review of Scientific Instruments, Volume 39 #10 1488-1490, October 1968, Unclassified

INITIAL DISTRIBUTION

Accessions Div (DIX-TC)	2	Falcon Research & Development	1
AUL/LSF 71-249	1	ADTC/XRS	1
ASD/ENFEA	1	USAFTAWC/TEF	1
Hq USAF/SAMI	1		
OO-ALC/MMWMP	2		
AFIS/INTA	1		
TAC/DRA	1		
TAC/INA	1		
US Army TRADOC Sys Analysis Act			
ATAA-SL	1		
USAFE/DCQ	1		
PACAF/DCOFQ	1		
ASD/XRP	1		
COMPAC/1-232	1		
AFATL/DLODL	9		
AFATL/DL	1		
ASD/ENYEM	1		
AFWL/LR	2		
AFATL/DLY	1		
AFATL/DLYV	6		
AFATL/DLYW	1		
AFATL/DLJW	2		
AFATL/DLM	1		
Orlando Tech, Inc	10		
Fowler, Fuehrer & Assoc, Inc	1		
Univ of Florida Grad Ctr	1		
Univ of Florida	1		
Rand Corp	1		
Naval Wpns Ctr/Code 407	1		
Ballistics Rsch Lab/AMXBR-VL	1		
Texas Tech Univ	1		
Defense Nuclear Agency	1		
GOI Ministry of Defense	1		
Oklahoma State Univ	1		
US Army Engineer Waterways Exp Stn	3		
AMSA/DIRXSY-D	1		
Physical Chemistry Div/Materials			
Research Labs	1		
Defense Research Establishment	1		
Royal Armament Research &			
Establishment	2		
Defense Research & Development Staff	1		
NSWC/Code WA-13	1		
Hq AFSC/DLCA	1		
Southwest Research Inst	1		
Naval Wpns Ctr/Code 3269	1		
ADTC/CEEDO	1		