

UNCLASSIFIED

AD NUMBER

ADB029235

LIMITATION CHANGES

TO:

Approved for public release; distribution is unlimited.

FROM:

Distribution authorized to U.S. Gov't. agencies only; Administrative/Operational Use; JUL 1977. Other requests shall be referred to Air Force Materials Lab., Wright-Patterson AFB, OH 45433.

AUTHORITY

AFWAL ltr 21 Sep 1982

THIS PAGE IS UNCLASSIFIED

AD B029235

AUTHORITY: AFWAL
1tr, 21 Sep 82



✓

LEVEL III (2)

18

19

AFMLTR-77-100-VOL-1
VOLUME I

see page 9 10 11

AD B 0 2 9 2 3 5

6

RELAXED MANUFACTURING DESIGN TOLERANCE
CONCEPTS
Volume I, Discussion and Summary

General Dynamics Corporation
Fort Worth Division
Fort Worth, Texas 76101

15 F33615-74-C-5444

AJ INU.
DDC FILE COPY

11 JUL 1977

12 138P.

10 Fred Lindstrom

9 Final Report, 1 April 1974-4 April 1977

DDC
RECEIVED
AUG 7 1978
REGULATIVE
A

Distribution limited to U.S. Government agencies only;
test and ~~performance~~ data; statement applied April 1977.
Other requests for this document must be referred to
Manufacturing Technology Division/LTC, Air Force
Materials Laboratory, Wright-Patterson Air Force Base,
Ohio 45433.

AIR FORCE MATERIALS LABORATORY
AIR FORCE WRIGHT AERONAUTICAL LABORATORIES
AIR FORCE SYSTEMS COMMAND
WRIGHT-PATTERSON AIR FORCE BASE, OHIO

78 08 04 072
402 709

NOTICE

When Government drawings, specifications, or other data are used for any purpose other than in connection with a definitely related Government procurement operation, the United States Government thereby incurs no responsibility nor any obligation whatsoever; and the fact that the government may have formulated, furnished, or in any way supplied the said drawings, specifications, or other data, is not to be regarded by implication or otherwise as in any manner licensing the holder or any other person or corporation, or conveying any rights or permission to manufacture, use or sell any patented invention that may in any way be related thereto.

This technical report has been reviewed and is approved for publication.

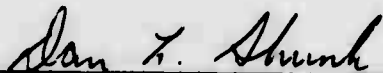

Capt. Dan L. Shunk
Project Engineer
Metals Branch
Manufacturing Technology Division

FOR THE DIRECTOR



H. A. Johnson
Chief, Metals Branch
Manufacturing Technology Division

Copies of this report should not be returned unless return is required by security considerations, contractual obligations, or notice on a specific document.

UNCLASSIFIED

SECURITY CLASSIFICATION OF THIS PAGE (When Data Entered)

REPORT DOCUMENTATION PAGE		READ INSTRUCTIONS BEFORE COMPLETING FORM
1. REPORT NUMBER AFML-TR-77-100, Vol. I	2. GOVT ACCESSION NO.	3. RECIPIENT'S CATALOG NUMBER
4. TITLE (and Subtitle) Relaxed Manufacturing Design Tolerance Concepts Vol. I	5. TYPE OF REPORT & PERIOD COVERED Final Report April 1974 - April 1977	
	6. PERFORMING ORG. REPORT NUMBER	
7. AUTHOR(s) Fred A. Lindstrom	8. CONTRACT OR GRANT NUMBER(s) F33615-74-C-5044	
9. PERFORMING ORGANIZATION NAME AND ADDRESS General Dynamics Corporation Fort Worth Division P.O. Box 748, Fort Worth, Texas 76101	10. PROGRAM ELEMENT, PROJECT TASK AREA & WORK UNIT NUMBERS DD 1473 - Report Documentation Page	
11. CONTROLLING OFFICE NAME AND ADDRESS Air Force Materials Laboratory (LTM) Air Force Systems Command 45433 Wright-Patterson Air Force Base, Ohio	12. REPORT DATE July 1977	
	13. NUMBER OF PAGES 137	
14. MONITORING AGENCY NAME & ADDRESS (if different from Controlling Office)	15. SECURITY CLASS. (of this report) Unclassified	
	15a. DECLASSIFICATION/DOWNGRADING SCHEDULE	
16. DISTRIBUTION STATEMENT (of this Report) Distribution limited to U. S. Government agencies only; test and analytical data <i>evaluation</i> statement applied April 1977. Other requests for this document must be referred to Manufacturing Technology Division, Air Force Materials Laboratory, Wright-Patterson Air Force Base, Ohio 45433		
17. DISTRIBUTION STATEMENT (of the abstract entered in Block 20, if different from Report)		
18. SUPPLEMENTARY NOTES		
19. KEY WORDS (Continue on reverse side if necessary and identify by block number) Relaxed Tolerance Surface Integrity Fatigue Life Design Guidelines Hand-Finishing End-Milling Mfg/Design Interface Measured Roughness Numerical Control Aluminum 6Al-4V Beta Annealed Programming Guidelines		
20. ABSTRACT (Continue on reverse side if necessary and identify by block number) This report describes the work on a program designed to relax design requirements on milled airframe parts. In addition, numerical control (NC) programming methods are optimized to decrease cutting time. Traditional design dimensional tolerances, and geometric details such as corner radii, are analyzed as to cost effectiveness,		

UNCLASSIFIED

SECURITY CLASSIFICATION OF THIS PAGE(When Data Entered)

and cost/weight trade-off data is developed. Guidelines for relaxation of specific detail design requirements are recommended for aluminum and titanium milled parts. Measured surface roughness is shown by component test to have no correlation with fatigue life, and revised surface roughness inspection guidelines are proposed. Hand-finishing of milled parts is shown to have little or no value in extending fatigue life. Geometric stress concentrations such as notches or fastener holes are shown to dictate fatigue life.

NC programming guidelines are developed by conducting stiffener machining tests and NC programming development tests. Two F-16 production parts are re-programmed and machined and eleven pieces and the revised programming are accepted for F-16 production. Cutting time is reduced substantially.

Design guidelines are incorporated into F-16 production airframe drawings from the beginning of production. Cost records show 22% reduced hand-finishing in the factory, and a 14% total cost reduction for milled aluminum parts for 1000 F-16 aircraft is conservatively projected.

F O R E W O R D

This final technical report covers work performed under Contract F33615-74-C-5044, "Relaxed Manufacturing Design Tolerance Concepts," from 1 April 1974 to 4 April 1977. The work was performed under the direction of the Metals Branch of the Manufacturing Technology Division of the Air Force Materials Laboratory at Wright-Patterson Air Force Base, Ohio. The original Project Engineer was Mr. John R. Williamson. The latter half of the program was under the direction of Capt. Dan L. Shunk.

The work was performed by the Fort Worth Division of the General Dynamics Corporation with Mr. Fred A. Lindstrom of the Structures and Design Department as Program Manager. Advisors included Mr. E. R. Collinsworth, Manager, Structural Design, Mr. L. M. Smith, Manager, Structures Technology, and Mr. W. D. Buntin, Director, Structures and Design. Participating team members were Mr. L. J. Hawkins, Supervisor, Manufacturing Technology, and Mr. F. P. Blanscet, Quality Control Engineer. Mr. C. E. Doyle and Mr. K. D. Mabry aided in engineering analysis and report preparation. Mr. R. L. Madarasz, Mr. U. H. Livingston and Mr. A. D. Crowe aided in programming and machining guideline development. Component testing was conducted by Mr. A. C. Shafer, and metallurgical examinations were performed by Mr. Z. R. Wolanski. Mr. J. W. Shaffer of Value Engineering advised on cost analysis and conducted implementation cost reduction analyses. Dr. W. P. Koster of Metcut Research Associates, Inc., provided valuable advice on surface integrity.

ACCESSION ID		
NTIS	White Section	<input type="checkbox"/>
DDC	Off. Section	<input checked="" type="checkbox"/>
UNANNOUNCED		<input type="checkbox"/>
JUSTIFICATION		
BY		
INSTITUTION/AVAILABILITY CODE		
MAIL	AVAIL. NO./W. SPECIAL	
β		

78 08 04 072

	<u>Page</u>
3.2.2.4.1 Breakdown of Machine Manhours	28
3.2.2.4.2 Breakdown of Hand-Finish Time	28
3.2.2.4.3 Total Cost Data Breakdown	29
3.2.3 Design Guidelines	29
3.2.3.1 Aluminum Design Guidelines	29
3.2.3.1.1 Nomograph for Cost Difference Between Two Sizes of Corner Radii	29
3.2.3.1.2 Limitation on Pocket Stiffener Spacing	40
3.2.3.1.3 Design Guideline for Corner Undercuts	40
3.2.3.2 Titanium Design Guidelines	42
4. SURFACE ROUGHNESS AND HAND-FINISHING	48
4.1 TEST DESCRIPTION AND HISTORY	48
4.1.1 Design and Analysis of Development Test Specimens	49
4.1.2 Design and Analysis of Verification Test Specimens	52
4.1.3 Manufacturing of Test Specimens	53
4.1.3.1 Selective Hand-Finishing on Test Specimens	55
4.1.4 Test Fixtures and Loading	56
4.1.4.1 I Beam Test Setup	56
4.1.4.2 Spar Segment Test Setup	58
4.1.4.3 YF-16 Titanium Frame Test Setup	58
4.1.4.4 Spectrum Loading	58
4.1.5 Test History	60
4.1.5.1 I Beam Test History	60
4.1.5.1.1 First Failure in Transition Bay	62
4.1.5.1.2 Transition Bay Reinforcement	62
4.1.5.1.3 Significance of Transition Bay Stress Concentration	62

	<u>Page</u>
4.1.5.1.4 Long Life with Re- inforcement	62
4.1.5.1.5 Titanium I Beams	63
4.1.5.1.6 Aluminum I Beams with Fastener Holes	64
4.1.5.2 Component Verification Tests	64
4.2 ANALYSIS OF RESULTS	66
4.2.1 Analytical Approach	67
4.2.1.1 Description of Analytical Methods	67
4.2.1.1.1 Surface Roughness vs. Equivalent Fatigue Life	67
4.2.1.1.2 Crack Distribution in Beams with Fastener Holes	74
4.2.1.1.3 Crack Distribution vs. Type of Finish	74
4.2.1.1.4 Variation in Notch Sensitivity Factor	77
4.2.1.1.5 Summary of Statistical Analyses	81
4.2.1.2 Analysis of Component Verifi- cation Tests	84
4.2.2 Conclusions Derived from Analyses	85
4.3 INSPECTION STANDARDS ON ROUGHNESS	86
5. NC PROGRAMMING AND MACHINING GUIDELINES	88
5.1 STIFFENER TESTS	89
5.1.1 Investigation for Overheating Effects and Smear Thickness	91
5.2 NC PROGRAMMING DEVELOPMENT TESTS	93
5.2.1 Development Test Description	93
5.2.2 Webs and Corners	98
5.2.3 Quality Comparison, S/N 10 vs. Baseline, S/N 2	98
5.2.4 Cost Reduction Indicated	101

	<u>Page</u>
5.3 REPROGRAMMING F-16 PRODUCTION PARTS	101
5.3.1 Effect of Guidelines on Metal Removal Rates	105
5.3.2 Effect of Guidelines on Cutting Time	107
5.3.3 Effect of Guidelines on Quality	107
5.3.4 Significance of Cutting Time Reduction	108
5.3.5 Re-Programming/Machining of Second F-16 Production Part	108
6. IMPLEMENTATION	114
7. COST REDUCTION ANALYSIS	115
7.1 GUIDELINE EFFECTIVITY	115
7.2 BASELINE AND F-16 COST DATA SOURCES	115
7.3 HAND-FINISH COST COMPARISON	115
7.4 TOTAL COST COMPARISON	116
7.5 NC REPROGRAMMING EFFECT ON COST	116
7.6 TOTAL ESTIMATED COST REDUCTION	117
8. REFERENCES	118

LIST OF ILLUSTRATIONS

<u>Figure</u>		<u>Page</u>
1	Detail Design Cost Reduction Features	5
2	Correlation Between Surface Roughness and Fatigue Life - I Beams without Fastener Holes	7
3	NC Programming/Machining Guideline Development	9
4	Typical Survey Data Record	12
5	Frequency of Occurrences - Dimensional Deviations on Webs and Stiffeners	17
6	Web Dimensional Deviations for Excessive Stiffener Spacing	19
7	Deviation Occurrences vs. Stiffener Spacing - Typical Record Plot	21
8	Design Comparison Part	24
9	Design Comparison Part as a Part of Production Design	26
10	Design Guideline - Flanged vs Vertical Stiffeners	33
11	Design Guideline - Lands vs No Lands	34
12	Design Guideline - Relaxed Web Land Requirement	35
13	Design Guideline - Stiffener Excessive h/t	36
14	Design Guideline - Increased Pocket Corner Radius	37
15	Design Guideline - Relaxed Dimensional Tolerance	38
16	Nomograph - Cost Difference Between Two Sizes of Corner Radii	39

LIST OF ILLUSTRATIONS (cont'd)

<u>Figure</u>		<u>Page</u>
17	Design Guideline - Tolerance Relaxation for Corner Undercut	41
18	Design Guideline - Titanium, Flanged vs Vertical Stiffeners	43
19	Design Guideline - Titanium, Land vs No Land	44
20	Design Guideline - Titanium, Relaxed Web-Land Requirement	45
21	Design Guideline - Titanium, Stiffener, Excessive h/t	46
22	Design Guideline - Titanium, Increased Pocket Corner Radius	47
23	Aluminum I Beam Fatigue Test Specimen	50
24	Aluminum I Beam with 1/4 Fastener Holes	50
25	Titanium I Beam Fatigue Test Specimen	51
26	F-111 Rear Spar Inboard Test Specimens	51
27	YF-16 Titanium Frame Test Specimen	54
28	I-Beams in Test Fixture	57
29	F-111 Rear Spar Specimens in Fatigue Test Fixture	59
30	YF-16 Titanium Frame in Fatigue Test Fixture	59
31	Correlation Between Surface Roughness and Fatigue Life - I Beams w/o Fastener Holes	73
32	Crack Distribution from 1/4" Fastener Holes in Aluminum I Beam Specimens	75

LIST OF ILLUSTRATIONS (cont'd)

<u>Figure</u>		<u>Page</u>
33	Residual Stress in Milled Aluminum	78
34	Correlation Between Notch Sensitivity Factor and Fatigue Life - I Beam Specimens	80
35	Correlation Between Notch Sensitivity Factor and Surface Roughness - Aluminum I Beams	82
36	Correlation Between Notch Sensitivity Factor and Surface Roughness - Titanium I Beams	83
37	Stiffener Machining Test on Bohle Vertical Mill	90
38	NC Programming Development Test Specimen	95
39	NC Programming Development - Quality Comparison	96
40	NC Development Test Specimen, S/N 10	99
41	NC Programming Development Tests - Cutter Time Variation	102
42	RTC Reprogrammed F-16 Part - 16B5222	103
43	RTC Reprogrammed F-16 Part - 16B1262	104

LIST OF TABLES

<u>Table</u>		<u>Page</u>
I	Work Sheet Tabulation of Survey Results	13
II	Factory Survey - Machining Dimensional Accuracy - Milled Aluminum Summary Table for Webs	15
III	Factory Survey - Machining Dimensional Accuracy - Milled Aluminum Summary Table for Stiffeners/Flanges	16
IV	F-111 Machined Parts Surface Roughness	22
V	Design Guideline Summary	30
VI	Design Guideline - Maximum Recommended Critical Panel Dimension vs Web Thickness for Aluminum	40
VII	Component Test Program Summary	61
VIII	Test Summary - Aluminum I Beams Without Fastener Holes	68
IX	Test Summary - Titanium I Beams	69
X	Test Summary - Aluminum I Beams With Fastener Holes	70
XI	Summary of Test Results at Site of Failure - I Beam Specimens	71
XII	Effect of Surface Finish on Fatigue Notch Sensitivity and Surface Roughness - I Beam Specimens	72
XIII	Correlation of Finish and Crack Frequency in I Beam Specimens w/o Fastener Holes	76
XIV	Stiffener Machining Test - Matrix of Test Numbers (Aluminum)	92

LIST OF TABLES (cont'd)

<u>Table</u>		<u>Page</u>
XV	Stiffener Machining Tests - Matrix of Test Numbers (Titanium)	92
XVI	Machining Parameters for Surface Effect Analysis	94
XVII	Summary Overall Comparison - S/N 2 and S/N 10	100
XVIII	Typical NC Programming Comparison - 16B5222-7	106
XIX	Machining Time Comparison - 16B5222-7	109
XX	Quality Comparison - 16B5222-7	110
XXI	Typical NC Programming Comparison - 16B1262	111
XXII	Machining Time Comparison - 16B1262	112
XXIII	Quality Comparison - 16B1262	113

NOMENCLATURE AND DEFINITIONS

The jargon and terminology of engineers, programmers and the machine shop, as used in this report, are defined below:

- AA - Arithmetic average; average of measured deviation from reference plane.
- APT - Automatic Program Tool, a specialized modification of Fortran language to convert drawing geometry into numerical coordinates.
- Area of Cut - is the product of radial cut and axial cut by an end-mill and is the amount of material engaged by the cutter, in square inches.
- Axial deflection or axial cut - deflection of material (web) or cutter along direction parallel to rotational centerline of cutter, or cutting done by a cutter moving along its rotational axis as in drilling or ramping.
- Block - a unit of spectrum test loading including a specific number, sequence, and magnitude of loads, applied repeatedly.
- Canning - distortion of a thin web out of plane due to internal residual stresses.
- Chatter - cutter vibration leading to a series of incomplete flute engagements of the material resulting in torn metal with burrs. This is an unacceptable surface condition in that the tears and burrs can initiate cracks and constitute initial flaws. The condition is usually due to a harmonic effect created by the cutter slenderless ratio and the RPM aggravated by low feed per tooth. Closely spaced wave peaks with "whole" surfaces between peaks are often erroneously classed as chatter.
- Dimensional deviation - a cutter may leave, or remove, material on a web or stiffener in excess of, or below, the thickness called for on the engineering drawing. This amount constitutes a deviation from the drawing dimension. The permissible amount of deviation is stipulated by the dimensional tolerance given on the drawing.

End-mill - is a cylinder with spirally curved cutting edges, or flutes, along its sides and also on the bottom. Cutters used on aluminum can have as few as two flutes. Titanium and steel end-mills may have six flutes. The end-mill can cut radially or axially, or both simultaneously.

Equivalent Life - the fatigue life predicted by the cumulative damage theory when converting a number of actual cycles of loading to failure at one or more stress levels to a predicted number of cycles to failure at another stress level.

Feed per tooth - is the depth of cut engaged by a flute during each rotation of the end-mill. It is a function of RPM and feed rate.

Feed rate - is the velocity with which material is fed into the cutter. Along with the area of cut, feed rate dictates the cubic inches of metal removed per minute. Motion is usually induced on a conventional mill by the table moving longitudinally or laterally and by the cutter moving vertically.

Finish machining - is the final machining to the drawing dimensions after the majority of metal has been removed by the "rough" machining. The finish cutter usually makes a light radial or axial cut, typically .015, .030, or .050 inches deep.

Flange - is usually the structural element along the border of an integrally stiffened part. It often carries heavy loads and is usually the most critical structural element of the part. It may be "L" or "T" shaped. It is machined by the side of the end-mill just as are stiffeners.

Flute - is the spirally shaped cutting edge on the surface of the cutter. See "end-mill".

Free travel - is the free movement by the cutter from one location on a part to another, usually at higher than feed rate (cutting) velocity.

K_f - The ratio of the fatigue strength of a specimen with no stress concentration to the fatigue strength at the same number of cycles with stress concentration for the same conditions, commonly determined by experiment.

- K_t - the ratio of the greatest stress in the region of a notch or other stress concentrator as determined by the theory of elasticity (or by experimental procedures that give equivalent values) to the corresponding nominal stress.
- Lay - is the direction of the trough or wave shape occasionally created by the side of the end-mill when milling at high feedrates and low RPM.
- Mean deviation - is the average deviation from the nominal dimension for a number of measured thicknesses of the same or differing dimensions, as used herein.
- Metal removal rate - is the cubic inches of metal removed per minute and is equal to the product of radial cut times axial cut times feed rate.
- Micro-inch - is one millionth of an inch, frequently referred to by the symbol μ .
- Mismatch - is a step in thickness on a web or stiffener made by two different cutter operations that inadvertently did not meet in the same plane.
- MSSL - maximum spectrum stress level; the stress produced by the highest applied load of a loading spectrum.
- NC - numerical control
- Nominal dimension - is the thickness, width, or length of an element called out as a dimension on the engineering drawing. It is always accompanied by a tolerance, or allowable deviation, from the nominal dimension.
- Numerical control (NC) - is the technique of controlling the motion of the end-mill cutter by a programmed tape input to the milling machine. It is used on a variety of types of machines.
- Pocket - is a volume bordered by a floor, or web, and walls, or stiffeners or flanges. It is created by milling metal out of a thick plate with end-mill cutters.
- Pre-penetrant etch - chemical removal of outer metal surface to remove smears and reveal flaws.

Programming - is the technique of creating input information to a computer whose output creates a tape which in turn controls the motion of a NC milling cutter in three linear dimensions and about two rotational axes.

q - fatigue notch sensitivity is a measure of the degree of agreement between K_f and K_t
 $q = (K_f - 1) / (K_t - 1)$

Radial cut - is a cut by the flute on the side of an end-mill and is measured by the difference in thickness of the material before and after the cutter pass.

Ramp - is an entry by an end-mill into a plate by combined axial and slot (radial) cutting. The cutter descends a steep slope into the plate with the flutes on the sides and bottom both removing metal. It is accompanied by heavy cutter forces.

Rough machining - is the relatively rapid removal of metal by an end-mill where little concern need exist for dimensional accuracy. More critical is the demand on the machine bearings, the cutter flutes and the hold-down tools due to the high cutter forces. Finish machining is then used to remove the remaining metal.

Roughness - see surface roughness

Router - is a machine similar to a milling machine in function but not in construction. A router moves the end-mill type cutter through the various motions and the part remains stationary. The cutter motion is controlled by the operator and a template that simulates the finished part. The same part can often be machined on a router or on a milling machine.

Slot cut - is the motion of an end-mill through material where the cutter engages material across its entire diameter and machines a slot. It is part of rough machining, after ramping in, and involves heavy cutter forces.

Smear - outer material of a milled surface deformed along plane of surface due to wiping action of the end-mill flute.

- Standard deviation - is a statistical term describing the average difference between individual values and the arithmetic mean. An amount equal to one standard deviation beyond each side of the mean includes 68.3% of all the predicted values for a normal distribution.
- Stiffener - is a structural element usually rectangular in cross-section that stabilizes the web (bottom) of a pocket. It seldom carries high loads, unlike the similar flange. It may also have an "L" or "T" shaped cross-section. It is machined by the side of the end-mill.
- Surface roughness - is the deviation of a surface profile from a perfectly smooth surface. It is measured by instruments that determine the arithmetical average (AA) deviation of the minute surface irregularities from a hypothetical surface, produced by a cutter in millionths of an inch or micro-inches, expressed as μ AA. A value of 125 μ AA is a commonly used upper limit on roughness.
- Tolerance - is the permissible deviation from a dimension given on an engineering drawing. The tolerance should be selected with due consideration of quality versus cost. A typical aerospace dimensional tolerance on milled parts is ± 0.010 inches.
- Tooling - for end-milling is the hardware provided to support the material being machined. It may include hold-down clamps, vacuum pressurized surfaces to hold thin webs in position, set-ups for moving the material rapidly from one machine to another, etc. It must be sturdy to withstand cutter forces and be easily assembled and dismantled.
- Under-cut - is the excessive removal of metal by an end-mill. It can occur in any mode during finish machining. It is most common in corners of pockets due to the small cutter diameter used.
- Web - is the bottom of a walled enclosure or pocket, usually thinner than the stiffener/flange walls around it. In typical aerospace parts it can range from a practical minimum of 0.040 inches to almost any amount. It is machined by the end of the end-mill. When very thin, accuracy is difficult to maintain and it is easily damaged.

μ - symbol used to designate micro-inch

Note: Throughout the report, definitions of terms are occasionally provided adjacent to the related text for easier reading.

1. INTRODUCTION AND SUMMARY

Under Contract F33615-74-C-5044, "Relaxed Manufacturing Design Tolerance Concepts," General Dynamics has developed quantitative guidelines that will permit relaxed manufacturing tolerances and thus reduce manufacturing cost. The program, sponsored by the Metals Branch of the Manufacturing Technology Division of the Air Force Materials Laboratory, was planned to meet a need which has received increasing attention in recent years.

At a meeting in Sagamore, New York, in 1972 the Air Force/ Industry Cost Reduction Study group identified three primary high-cost manufacturing areas: material utilization, assembly, and material removal. The group also identified an equally critical overlying problem: manufacturing/design interface, which directly impacts cost.

The high cost of manufacturing is still increasing since current aircraft designs tend to require more machined parts than those of the past. The designer of these parts usually does not have available information as to how cost-effective his design is. Although he knows its benefit to aircraft performance in terms of added range or increased payload, he does not know the cost impact of a given dimensional tolerance or a small radius in a pocket corner or how to optimize his design for minimum-cost machining and finishing. Consequently, his decisions usually favor those features that enhance aircraft performance. These decisions, made with inadequate knowledge of the manufacturing process, actually dictate the manufacturing process, the type of tooling, and the intensity of inspection required. This traditional approach to design usually results in a cost that is higher than necessary.

The conclusions reached at Sagamore were examined in more detail at a Design/Manufacturing Interface Seminar conducted in French Lick, Indiana, in May 1973. Also examined at the seminar was the practice of hand-finishing machined parts to control surface roughness and fatigue life.

In a related effort, Metcut Research Associates, Incorporated, under contract to the Air Force Materials Laboratory, Manufacturing Technology Division, found a lack of relationship between surface roughness and fatigue life for certain metals

including aluminum. Similar work at General Dynamics Fort Worth Division under corporate sponsorship showed the same result.

In April 1974, the contract documented in this final report was awarded to General Dynamics to develop quantitative relationships between design features and manufacturing cost in the form of design guidelines. It was also intended to determine the relationship, if any, between surface roughness and fatigue life of aircraft components. In an addition to the contract, AFML called for the development of more efficient methods of milling aluminum. These methods were to capitalize on program developments, which permitted relaxation of traditional design, tolerance, and surface finish requirements.

1.1 OBJECTIVE AND SCOPE

The objective of the task assigned to General Dynamics by the Metals Branch was to achieve significant cost reduction in the production of aerospace machined parts by the following means:

1. A discrete relaxation of dimensional tolerances, with cost-effective results in terms of performance and quality.
2. A relaxation of surface finish requirements based on tests verifying adequacy of surface integrity.
3. Development of design analysis guidelines providing cost-weight trade-off data for design optimization.
4. Development of numerical control programming guidelines that will reduce machining cost by increasing metal removal rates without loss in quality of product.

The scope of the investigation was defined in terms of five program phases:

- Phase I - Analysis of F-111 and YF-16 airframe design drawings to identify cost-sensitive geometric features and dimensional and surface tolerances.
- Phase II - Identification of those surface finish requirements that are candidates for change and evaluation of the cost effect of such changes.
- Phase III - Determination of the effect of dimensional tolerance requirements on cost and weight, performance of cost analyses, and proposal of design changes.
- Phase IV - Establishment of the acceptability of proposed design relaxations by designing, manufacturing, and fatigue testing typical airframe components.
- Phase V - Performance of the machining tests necessary to develop numerical control programming guidelines that will permit reductions in machining costs without loss in quality and demonstration of the acceptability of the guidelines by reprogramming two F-16 aluminum production parts, and machining five of each part.

As the program progressed, the five phases overlapped and merged with each other. This interaction illustrated the interdependence of the various functions and the importance of the basic program objective: investigation of the design/manufacturing interface.

1.2 RECOMMENDATIONS ON GUIDELINES

Most of the design and manufacturing practices examined during the relaxed tolerance concepts (RTC) program have been traditional throughout the aerospace industry for many years. Hence, it was encouraging to the investigators to have most of the proposed guidelines - some of which depart from these practices - accepted almost immediately for F-16 design and

manufacturing. Because of the F-16 acceptance of these guidelines, recommendations can be made with a reasonable level of confidence that the proposed guidelines (Figure 1) are practical and useful and will reduce cost.

1.2.1 Detail Design

The quality of detail design on an airframe part is measured by adequacy of strength and functional provisions, by the degree of achievement of minimum weight, and by cost of manufacturing, usually in decreasing order of importance to the designer.

By providing the designer with a better understanding of the relation between weight and cost through quantitative guidelines and by providing evidence that strength is not adversely affected by a discrete relaxation of surface and dimensional requirements, cost is reduced and detail design quality is achieved more cost-effectively. Cost/weight details are provided in section 3.2.3.

Recommendations are as follows:

1. Relax dimensional tolerances on nominal thickness for flanges and stiffeners - elements machined with the side of the end-mill - from the traditional ± 0.010 inch to $+0.015$, -0.010 . Rejections and hand-finishing cost will reduce significantly as will machining cost.
2. Do not relax the traditional ± 0.010 inch dimensional tolerances on the nominal thickness for webs - elements machined by the end of the end-mill. Control is easier to maintain and weight is more sensitive to tolerance than is the case for flanges and stiffeners.
3. Consider relaxation of requirements on geometric features such as corners of pockets and "lands" to the extent described in section 3.2.3. Cost/weight trade-off analysis will usually show this to be profitable for anything other than a space vehicle.

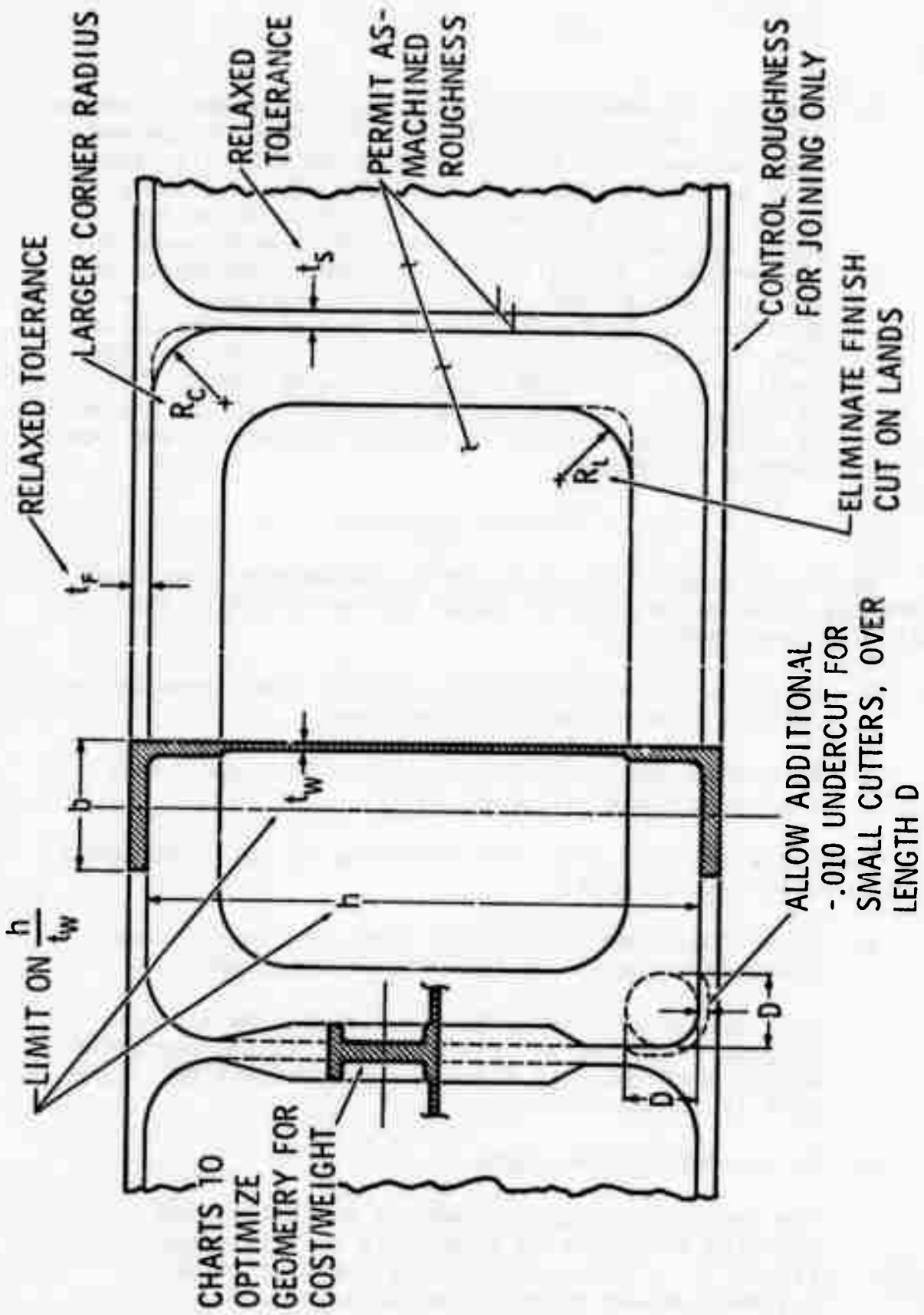

FIGURE 1 DETAIL DESIGN COST REDUCTION FEATURES

4. Consider allowance of an additional negative tolerance of 0.010 inch for a total of -0.020 inch in corners that are cut with small flexible cutters, i.e. less than 1 inch in diameter. Drafting practice may require that this allowance be set forth in an inspection standard and the standard be referenced on the drawing. Where such a decrease in thickness is not acceptable (and this is seldom the case), the designer should specify an increase of nominal thickness. Undercuts, which are chronic in corners with small radii, are almost always "bought off." The relief offered by the added tolerance will be extremely profitable in terms of reduced inspection and engineering paperwork.

1.2.2 Surface Roughness

As illustrated in Figure 1, it is recommended that hand-finishing of aluminum airframe parts be restricted to the following functions only:

1. To correct unacceptable dimensional discrepancies resulting from the machining process.
2. To produce an acceptable roughness in areas requiring contact with adjacent parts.

It should be noted that hand-finishing is not recommended for the following purposes:

1. To eliminate normal milling waves and swirls from aluminum surfaces for the sake of appearance.

Such irregularities do no functional harm and are largely dispelled by pre-penetrant etching and painting of surfaces. As a result, measurement of roughness is seldom necessary.

2. To control milled roughness.

The lack of correlation between durability and measured roughness of components is illustrated in Figure 2. A discussion of the correlation and residual stress is presented in section 4.2.

1.2.3 NC Programming and Machining

The NC programming/machining guidelines, presented in Appendix L, are too complex to present here as specific recommendations; however, general recommendations as to the use of these guidelines are appropriate and are set forth below:

1. Relieve the machine operator of as much responsibility as possible by the use of adequate instructions and by providing a program with feed rates that do not require operator override.

The programming guidelines presented in Appendix L are intended to provide such guidance and are applicable to a majority of conventional aluminum airframe parts. Less experienced operators may be used when this recommendation is followed.

2. Reduce machining time substantially below that required by conventional programming by using the guidelines of Appendix L.

Experience to date in the application of the guidelines, admittedly limited, indicates a 25 to 50% reduction in total time on the machine if the guidelines are rigorously applied. The result is a saving in manpower, capital equipment, and schedule time.

Figure 3 illustrates the development program conducted to create the guidelines producing these benefits.

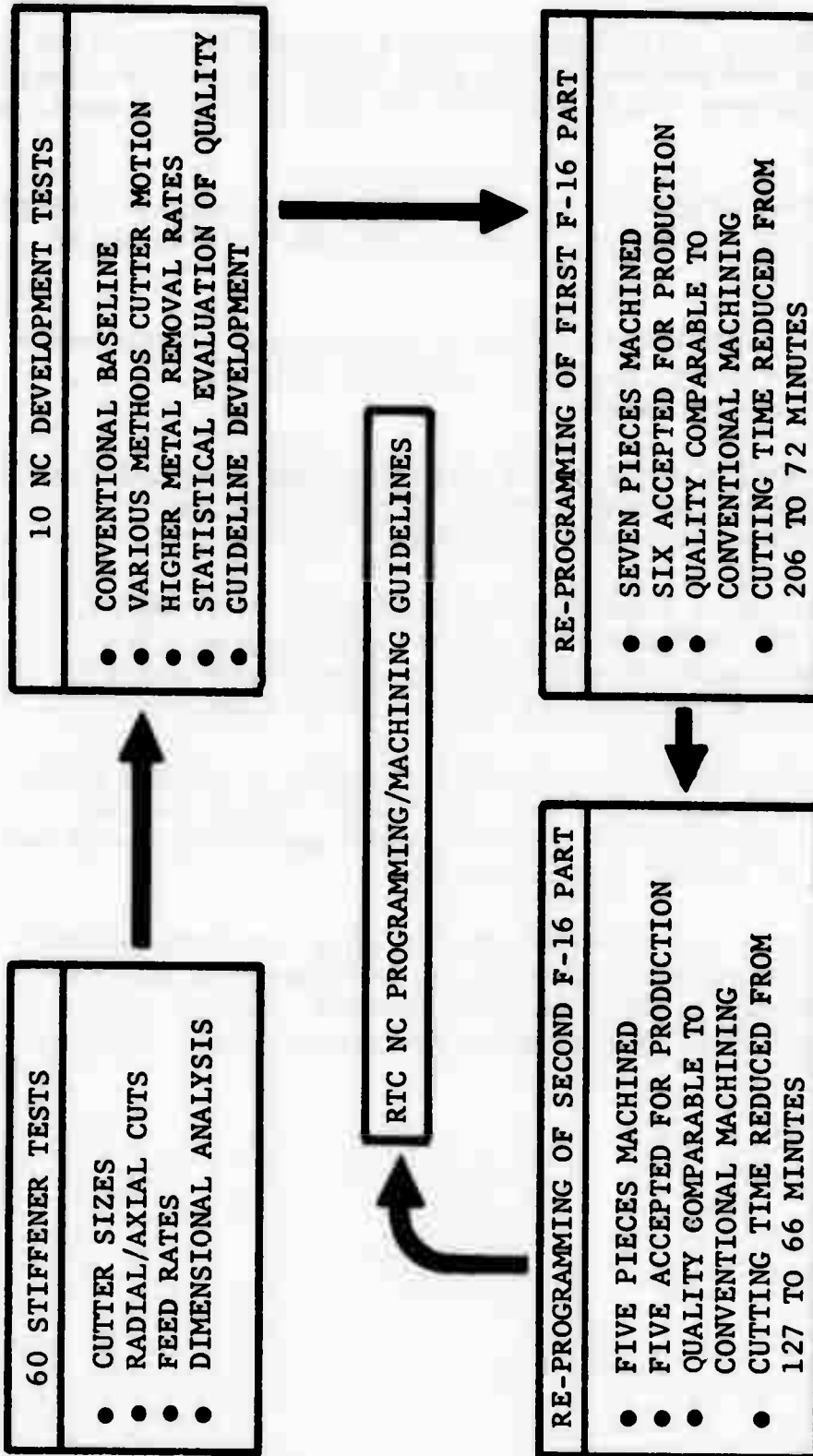

FIGURE 3 NC PROGRAMMING/MACHINING GUIDELINE DEVELOPMENT

2. CONCLUSIONS

The results of analytical and test investigations into traditional design and manufacturing practices for milled aluminum and titanium airframe parts have led to the following basic conclusions:

1. Measured roughness is not related to fatigue strength in either aluminum alloys or 6Al-4V beta annealed titanium.
2. Properly milled surfaces on aluminum airframe parts need not have roughness measured for reasons involving strength.
3. Hand-finishing is not a cost-effective method for increasing fatigue life in either aluminum or 6Al-4V beta annealed titanium.
4. Conventional dimensional tolerances on elements machined with the side of the end-mill may be relaxed substantially with little weight penalty and with a significant reduction in cost.
5. Designing certain geometric details on milled parts so as to permit the use of larger finish cutters is often cost-effective in terms of man-hours saved per pound of weight not removed.
6. Metal removal rates as produced by conventional NC programming and machining of aluminum can be increased by as much as 100% without genuine loss in quality by use of more efficient cutter motion.

3. DESIGN GUIDELINE DEVELOPMENT

This section describes how basic data was obtained from the manufacturing and design areas and analyzed so as to develop cost/weight relationships for design guidelines.

3.1 SURVEY OF MACHINE SHOP CAPABILITY

In order to make recommendations on relaxing dimensional tolerances, it was found necessary to determine the capability of the machine shop to meet the then current dimensional and surface quality requirements of the engineering drawings. Over a period of five months in 1975 the RTC Quality Assurance team member and F-111 production inspectors surveyed milled aluminum parts. Thorough analysis of this data revealed a wealth of useful information on the cost-effectiveness of engineering requirements and resulted in some useful changes in the configuration, dimensioning and tolerancing of F-16 machined parts. These were incorporated into the GD/FWD Design Manual and were part of the instructions to designers issued by the F-16 Chief Engineer at the beginning of the F-16 FSD design phase. All F-16 milled aluminum airframe parts incorporate one or more of the design benefits derived.

Appendix B presents the raw data obtained and the manner of processing the data. The recommendations derived are discussed in the following paragraphs and presented in section 3.2, Detail Design Analysis.

3.1.1 Data Gathering and Processing

Eleven major F-111 aluminum milled parts were inspected with up to five pieces of each design, for a total of 36 pieces. One thousand and seventy thickness measurements were made on areas cut with the end of the end-mill (webs) and 866 measurements on areas cut with the side of the end mill (stiffeners and flanges). Parts known to have problem areas were excluded for separate consideration on the assumption that anticipated design guidelines would reduce the likelihood of unnecessarily difficult designs in the future. This has generally held true on the F-16 program.

3.1.1.1 Organization of Survey Data

Measurements were recorded on sketches of each part as shown in Figure 4 and tabulated in the form of Table I. The drawings were then consulted for the required thicknesses and pocket widths, and these values were entered as shown in Table I. The deviations from the nominal drawing dimensions were then calculated and entered.

TABLE I WORK SHEET TABULATION OF SURVEY RESULTS

DWG. NO. 12B2703-83

HAND FIN

DATE 4/15/75

AS MACHD

WEBS							STIFFENERS/FLANGES				
#	DWG t	POCKET WIDTH	S/N F193900		S/N F186213		DWG t	S/N F193900		S/N F186213	
			DATE	3/21/75	DATE	3/21/75		DATE	3/21/75	DATE	3/21/75
			ACTUAL t	Δt	ACTUAL t	Δt		ACTUAL t	Δt	ACTUAL t	Δt
1	.045	4.5	.056	.011	.051	.006	.105	.117	.012	.116	.011
2	.045	5	.054	.009	.052	.007	.105	.117	.012	.116	.011
3	.045	5	.055	.010	.052	.007	.100	.101	.001	.105	.005
4	.045	5	.056	.011	.053	.008	.100	.101	.001	.106	.006
5	.045	5	.053	.008	.053	.008	.150	.163	.013	.162	.012
6	.045	3.5	.056	.011	.054	.009	.100	.102	.002	.105	.005
7	.055	2	.053	-.002	.062	.007	.110	.124	.014	.122	.012
8	.065	4.5	.078	.013	.076	.011	.110	.122	.012	.119	.009
9	.055	4.5	.067	.012	.063	.008	.110	.110	0	.114	.004
10	.065	3	.079	.014	.077	.011	.100	.102	.002	.105	.005
11	.055	4.2	.066	.011	.064	.009	.125	.126	.001	.129	.004
12	.065	6.7	.078	.013	.078	.013	.100	.108	.008	.105	.005
13	.055	7.2	.067	.012	.067	.012	.100	.103	.003	.106	.006
14	.055	6.7	.065	.010	.064	.009	.100	.101	.001	.105	.005
15	.065	4.2	.077	.012	.079	.014	.150	.164	.014	.162	.012
16	.055	4.8	.066	.011	.066	.011	.100	.101	.001	.105	.005
17	.055	7.5	.065	.010	.065	.010	.100	.101	.001	.105	.005
18	.065	2.0	.077	.012	.079	.014	.105	.116	.011	.116	.011
19	.055	7.2	.064	.009	.063	.008	.105	.118	.013	.117	.012
20	.055	7.2	.066	.011	.061	.006					
21	.055	7.2	.065	.010	.063	.008					
22	.065	5.4	.079	.014	.078	.013					
23	.055	7.5	.068	.013	.065	.010					
24	.065	4.9	.078	.013	.078	.013					
25	.055	6.8	.066	.011	.065	.010					
26	.065	3.7	.077	.012	.078	.013					
27	.055	4.2	.066	.011	.066	.011					
28	.065	4.2	.076	.011	.076	.010					
29	.055	4.2	.066	.011	.065	.010					
30	.045	3.5	.055	.010	.055	.010					
31	.055	2	.064	.009	.062	.007					
32	.045	5	.053	.008	.054	.009					
33	.045	5	.053	.008	.053	.008					
34	.045	5	.053	.008	.053	.008					
35	.045	5	.054	.009	.053	.008					
36	.045	4.8	.054	.009	.053	.008					

3.1.1.1 (Cont'd)

Next, the deviations were tabulated to create a frequency distribution. The total number of deviations were determined versus the magnitude of the deviation. The totals were then accumulated from the largest minus value to the highest plus value, and these cumulatives were then converted to a percentage of the total number of measurements. Table II shows the data for webs and Table III for flanges and stiffeners.

Deviations from web nominal dimensions were plotted versus panel width for several designs to observe the tendency of deviations from the nominal thickness for various web thicknesses discussed in 3.1.2. This led to proposed limits on pocket width for each nominal web thickness, described in 3.2.3.

Surface roughness was also measured and recorded, but in view of the obvious consistent and good quality of milled surfaces, the costly profilometer readings were discontinued after some 70 readings. This data is also described in 3.1.2.

3.1.2 Data Analysis

The survey data was analyzed for the purpose of determining to what degree present design practices were within shop capability on milled aluminum.

3.1.2.1 Dimensional Tolerance

Figure 5 is the plot of the data generated in Tables II and III. As expected, elements cut with the side of the end mill (stiffeners/flanges) showed the larger positive dimensional deviation due to inherent flexibility in both cutter and part material due to lateral loads.

Stiffeners/flanges exceeded the conventional +0.010 inches tolerance in a surprising 23% of the occurrences and exceeded +0.015 inches in 10%. Webs exceeded +0.010 12% of the time. Negative deviations did not appear to be significant. These results suggested that tolerances for stiffener/flanges might be relaxed if accompanied by an acceptably small weight increase. Also, a significant amount of hand-finishing and inspection rejections could be avoided if, for example, discrepant stiffeners/flanges could be reduced by over 50%, from 23% to 10% by permitting a +0.015 inch tolerance for these elements.

Data Base:	Number of Measurements - Webs:	1,070
	Number of Measurements - Stiffeners:	866
	Number of Part Numbers:	11
	Number of Pieces:	36

Notes:

- (1) Data was Gathered During November 1974-March 1975 by General Dynamics Inspection on F-111 Production Aluminum Machined Parts
- (2) Analysis was Restricted to Parts with ± 0.010 Tolerance, Excluding Parts with History of Material Warpage or Other Problems

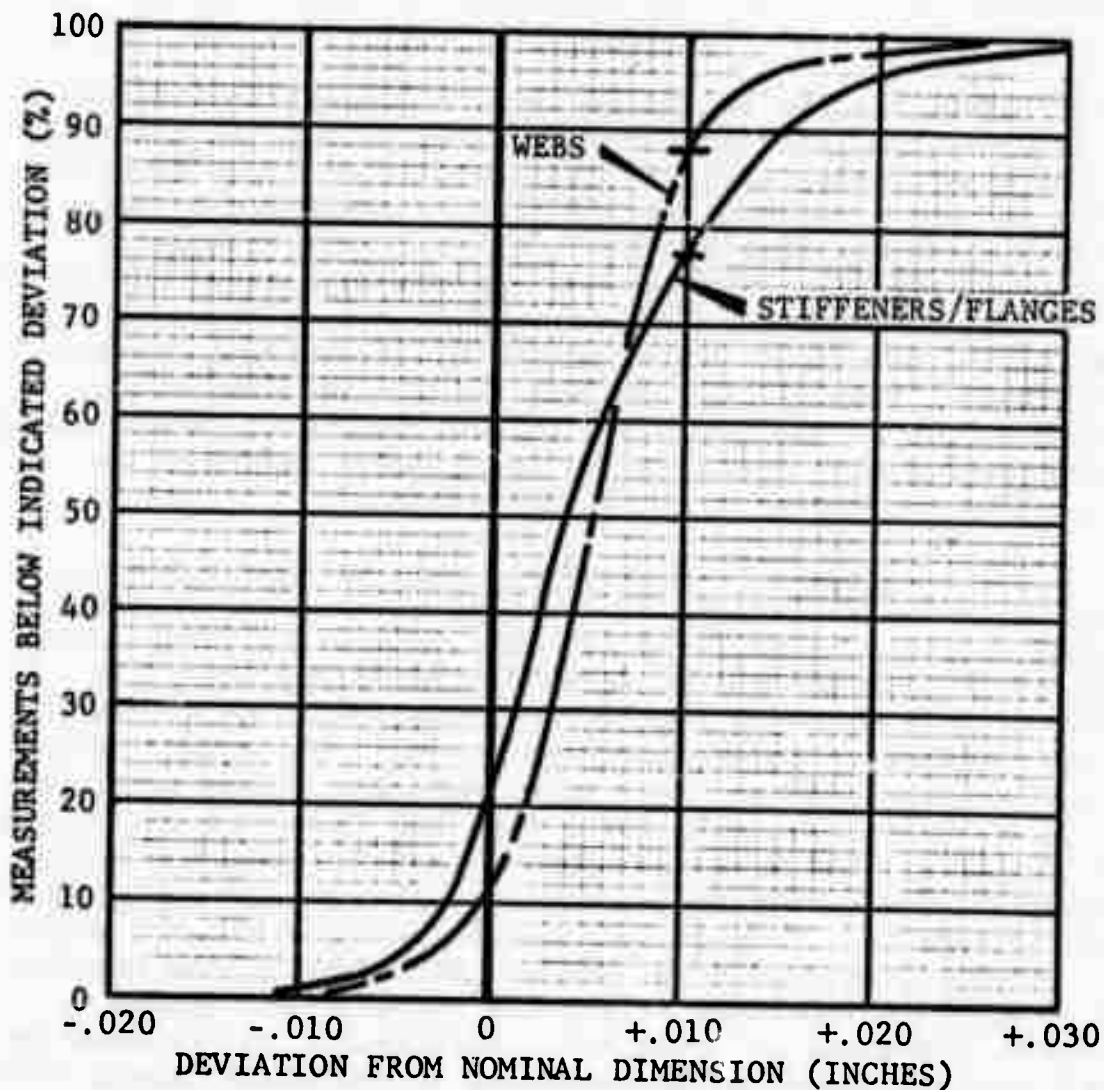

FIGURE 5 FREQUENCY OF OCCURRENCES - DIMENSIONAL DEVIATIONS ON WEBS AND STIFFENERS

3.1.2.1 (Cont'd)

Analysis of Figure 5 is presented in paragraph 3.2.3, Design Guidelines, for the effect on weight and cost.

3.1.2.2 Design Configuration

A common and costly cause of machined parts rejections is warpage during machining. Rolling and heat treatment induce high internal residual stresses that are often not removed by tempering the 2-6 inch thick aluminum plates commonly used for milling integrally stiffened parts. Consequently, a plate that is initially flat may warp and destroy dimensional accuracy as metal is progressively removed, and the remaining residual stresses seek their new internal load equilibrium.

Efficient, minimum weight design of integrally stiffened parts requires that webs and stiffeners be as thin as loads and machining capabilities permit. As a result, webs may be as thin as 0.040 inches. Stiffener weight will be minimized by using the widest stiffener spacing that will still retain buckle resistance of the web. This design approach has resulted, in the past, in stiffener spacing large enough to permit "canning" of the web during the final finish machining as residual stresses are modified. "Canning" may deflect the web into the cutter, producing a hole in the web. Or, the web may be so flexible that the natural tendency of the end of the endmill flutes to pull material into the cutter will produce a hole.

3.1.2.2.1 Example of Excessively Wide Stiffener Spacing.

The web thickness deviations of the type illustrated by Table I were plotted for a large F-111 bulkhead (Figure 6). This data illustrates the result of excessive stiffener spacing. All the webs of this bulkhead were 0.040 inches thick as a result of a major effort to reduce airframe weight. The weight saving was largely lost, however. The thin, wide web lacked sufficient stiffness to resist the pull force from the flutes on the bottom of the end mill. The webs also tended to "can" into the cutter. Consequently, the cutter frequently cut holes in the web, requiring costly repairs. Finally, engineering relaxed the web positive tolerance from +0.010 to +0.020. As a result, the machine operator quite legitimately raised his cutter 0.010 inches, effectively producing an 0.050 web. This result can be seen in Figure 6 where a number of measurements on the wider panels showed a deviation over +0.010 inches. Even when the tolerance had been relaxed to +0.020, machining accuracy was not adequate to prevent frequent deviations beyond the +0.020 inch allowance.

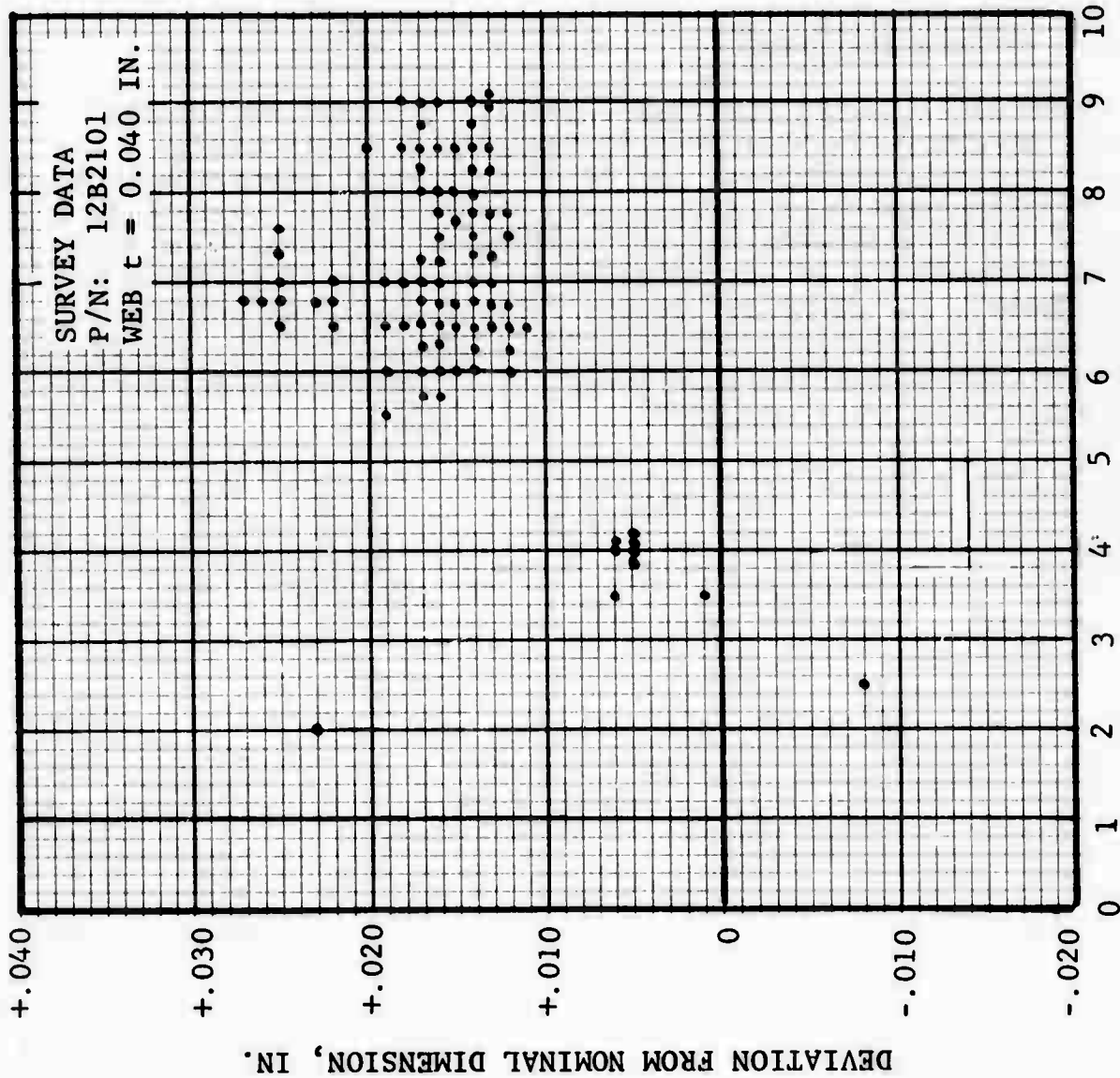

FIGURE 6 WEB DIMENSIONAL DEVIATIONS FOR EXCESSIVE STIFFENER SPACING

3.1.2.2.2 Stiffener Spacing vs. Dimensional Deviation. The raw data of the type shown in Table I and in Appendix B were then organized for correlation between machining accuracy and stiffener spacing. This correlation is shown in Figure 7 for a web thickness of 0.050 inches. There clearly exists a trend towards higher deviation from the nominal dimension as stiffener spacing increases. Similar plots were prepared for thicknesses from 0.040 to 0.085 inches (Appendix B).

3.1.2.3 Surface Roughness

Table IV lists the roughness readings obtained during the survey. Measurements were made on some parts before and on others after hand finishing. It is of interest to note the lack of correlation between roughness and "hand-finished" parts. In Table IV, 49 measurements are on as-machined surfaces. The mean roughness was 43.3 μ AA with a standard deviation of 13.57 on 47 measurements. The other two points reflected a minor cutter malfunction (P/N 12B4166, S/N 2). The combined was 50.3 (36.9). On the so-called hand finished surfaces, 22 measurements resulted in 69.9 (19.14).

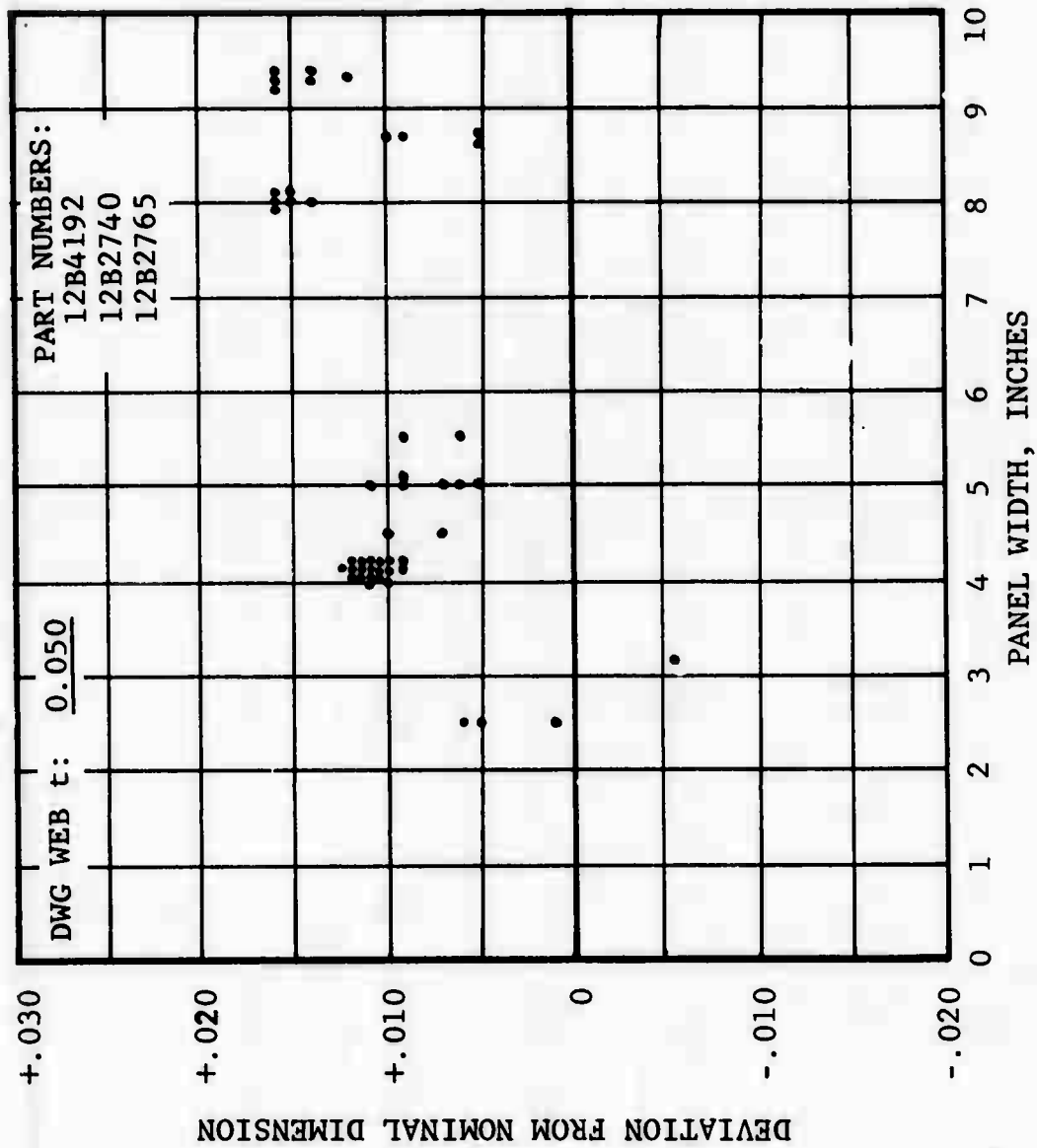

FIGURE 7 DEVIATION OCCURRENCES VS. STIFFENER SPACING -
TYPICAL RECORD PLOT

TABLE IV F-111 MACHINED PARTS SURFACE ROUGHNESS

P/N	S/N *	Dwg Web t (in.)	Roughness (μ AA)	Dwg Web t (in.)	Roughness (μ AA)
12W902-25	#1 (A-M)	.117	33	.100	39
		.117	45	.130	43
		.117	28	.130	41
		.117	47	.130	47
		.117	41	.110	41
		.100	62	.160	19
				.140	56
	#2 (A-M)	.140	67	.125	55
		.117	21	.100	54
		.117	51	.100	40
		.117	56	.130	44
		.117	49	.130	45
		.117	48	.220	59
		.117	46	.160	25
.125		37			
12W902-19	F190388 (A-M)	.286	44	.055	50
		.077	33	.385	50
		.050	41	.065	45
12B42680	#1 (A-M)	.095	58	.070	22
		.095	49	.120	53
		.095	42	.095	54
		.095	52	.105	61
		.095	67		
	F187633 (H-F)	.095	63	.070	65
		.095	62	.095	58
		-	56	.095	54
12B4166	#1 (A-M)	.125	9		
		.125	25		
		.125	28		
	#2 (A-M)	.125	221	.125	13 (opp. side)
		.125	210		
12B4021-107	F178237 (H-F)	.064	86	.064	48
		.064	101	.064	70
		.064	84	.064	49
		.064	41	.064	51
		.064	99	.064	107
		.064	86	.085	46
		.064	71	.064	76
		.064	77	.064	87

Results: 49 measurements on As-Machined surfaces
 Mean = 50.3 in AA, standard deviation = 36.9
 22 measurements on Hand-Finished surfaces
 Mean = 69.9 in AA, standard deviation = 19.14

* Where parts were not serialized, pieces were given the numbers shown.

3.2 DETAIL DESIGN ANALYSIS

The following paragraphs describe the manner in which cost/design guidelines were developed. Also, design guidelines are summarized based on the details presented in Appendix A.

3.2.1 Design of Baseline Part and Competitive Details

The shop survey described in 3.1 provided useful basic information on what the machine shop can and cannot do, thereby contributing to better understanding of the role of dimensional tolerance and design configuration.

In addition, a survey of F-111 and YF-16 machined parts was conducted to identify the various major features of design. Parts selected were limited to aluminum and titanium parts weighing five pounds or more, with the following breakdown:

	<u>Number of Parts</u>		
	<u>F-111</u>	<u>YF-16</u>	<u>Total</u>
Aluminum	89	63	152
Titanium	<u>7</u>	<u>5</u>	<u>12</u>
Total	96	68	164

These parts were classified according to their major geometric features, i.e. (1) parts with pockets on both sides, (2) pockets on one side, and (3) special shapes such as zees, tees, Y sections, etc. The competing geometric details for the design comparison parts evolved from this survey in the form of web lands, flanged stiffeners, warped contour flanges, thin tall stiffener, corner radius, and dimensional tolerances.

It also became clear that the high cost of machining is caused not by the heavy, local concentrations of special purpose material, but, instead, by the areas of low load or minimum thickness where the tolerance is a significant percentage of the thickness. Consequently, it was for these areas that guidelines were developed.

The baseline configuration is shown in Figure 8 along with the competing alternate details. Not all of these developed as useful comparisons, but all were analyzed and are described in detail in the tables of Appendix A. The baseline is representative

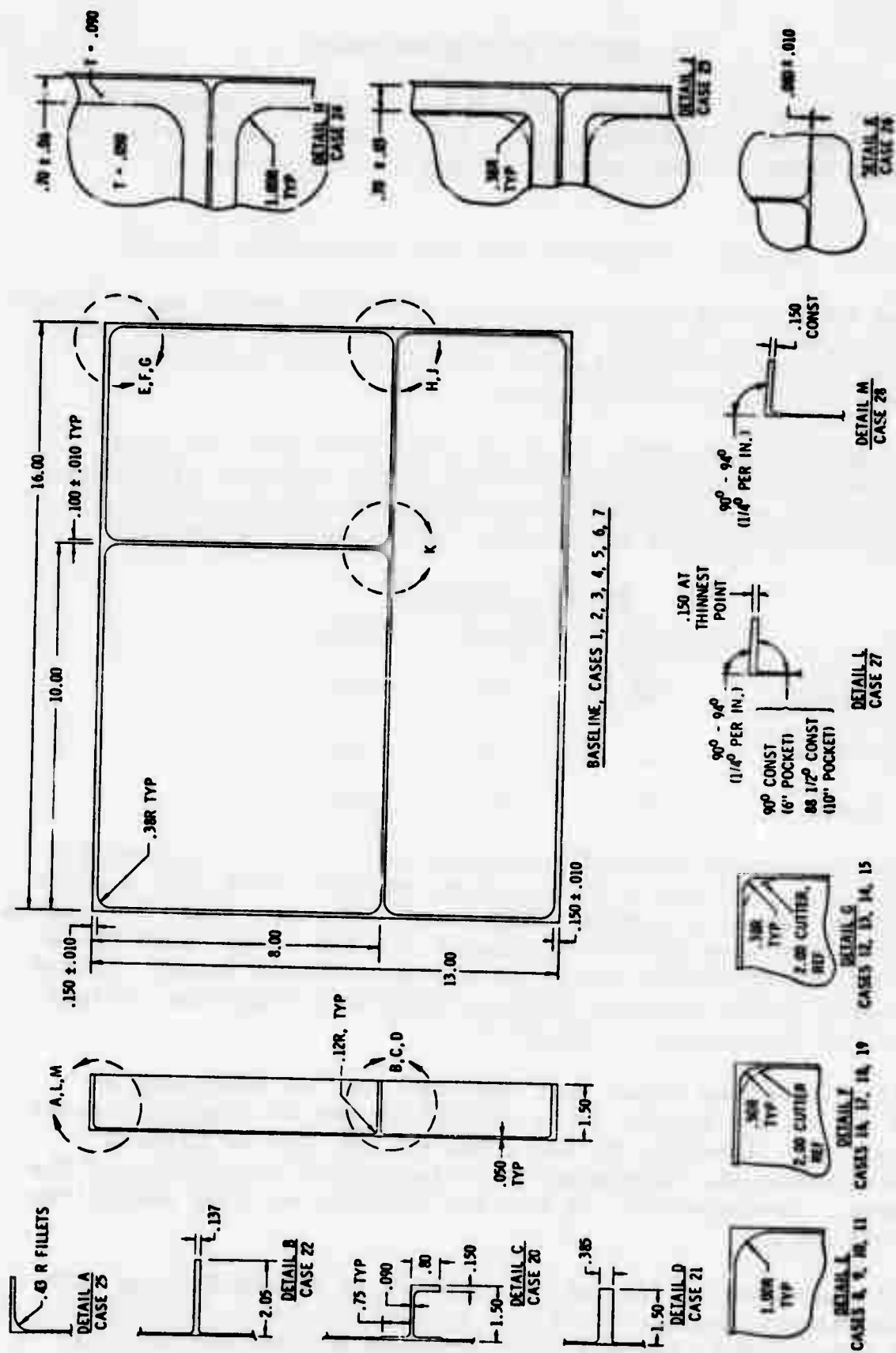

FIGURE 8 DESIGN COMPARISON PART

of segments of many larger parts as illustrated in Figure 9. Also it is large enough to demonstrate the effect of the various design features, and yet minimized the NC programming task required. Programming was completely conventional and realistic as if parts were actually to be machined.

Pockets were provided on one side only, since whether a part should have pockets on both sides or not is seldom a design option, but is, instead, usually dictated by required flange width or the need for structural attachment to one or both sides.

The baseline configuration and alternates shown on Figure 8 are applicable for both aluminum and titanium.

3.2.2 Basic Data Development for Comparison Parts

Normal methods of estimating cost are usually not sensitive to differences in detail design or small weight differences, so a better procedure was needed. When it was discovered that NC tape time was used by the factory as a guide to scheduling parts, the necessary approach was self evident. This section describes how the various configurations were NC programmed and how manhour costs were derived from this programming. The detailed data is presented in Appendix A.

3.2.2.1 Weight Change and NC Tape Time

Twenty-eight cases were analyzed in Appendix A, Table A-1 for aluminum, as to weight change, cubic inches removed, cubic inches remaining, and machining operations. Tape time per cutter operation and total tape time were determined. The 28 cases included not only configuration cases but also cases with relaxed dimensional tolerance, relaxed surface finish requirements, varying feed rates, and various cutter sizes and cutter paths. Programming was done by an experienced programmer and was computer processed to yield a data print-out for engineering analysis. Similarly, Table A-V presents data from a computer printout for titanium comparison cases.

3.2.2.2 Cost Analysis of 31 Aluminum F-111 Parts

In order to develop a data base for relating design comparison part tape time to manhours, cost data for F-111 aluminum and Advanced Metallic Air Vehicle Structure (AMAVS) titanium parts was obtained from the various factory task center records. These are available on microfiche and show NC machining, hand

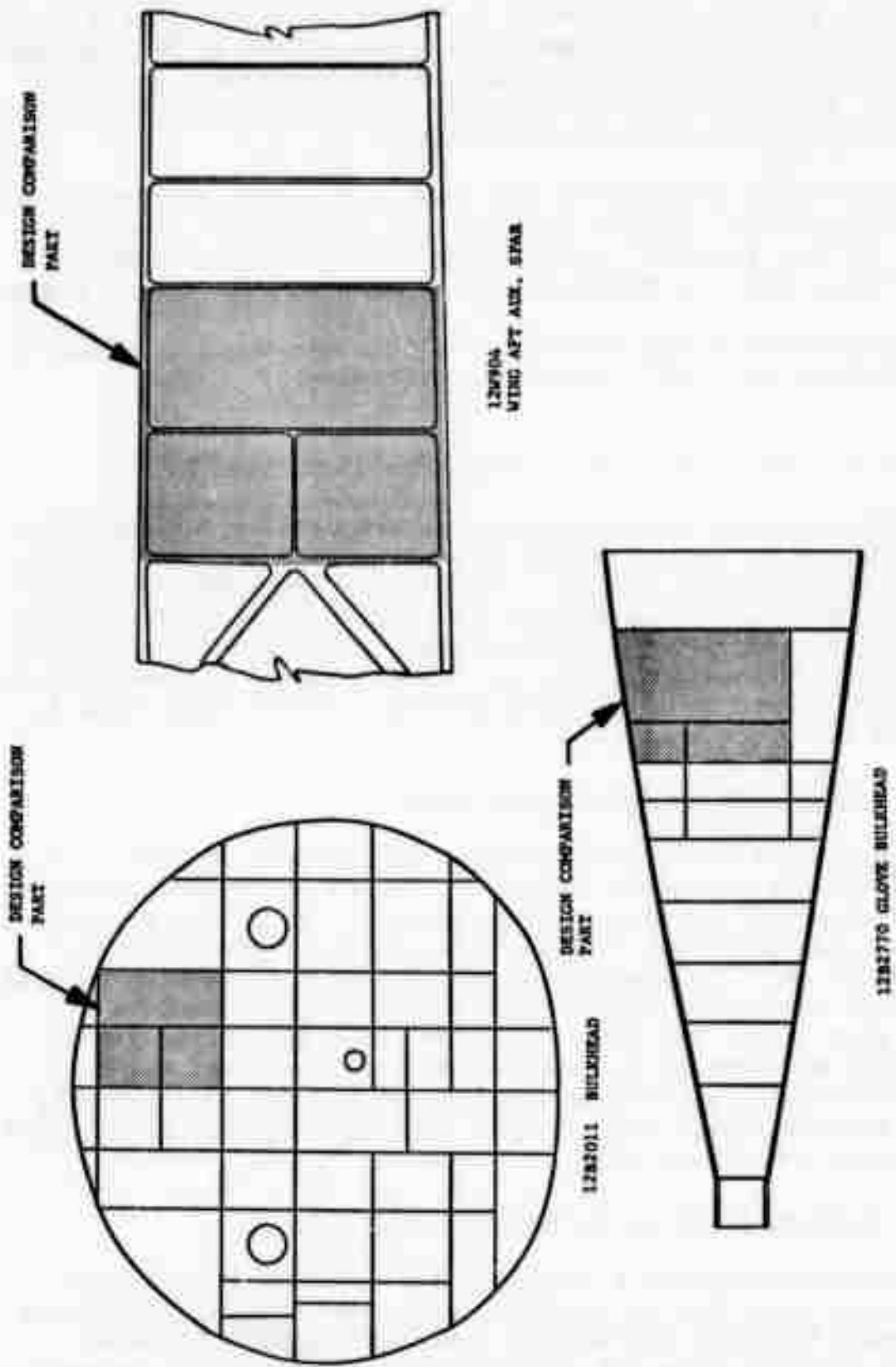

FIGURE 9 DESIGN COMPARISON PART AS A PART OF PRODUCTION DESIGN

finishing and other process costs in manhours. From the cost records of the Value Engineering group, the cubic inches removed and remaining were obtained. Tape time for each part was obtained from Manufacturing Control.

NC machining manhours were adjusted from multiple spindle to single spindle manhours. Three categories of manhours were then tabulated, (1) NC machine manhours, (2) hand-finish manhours, and (3) all other manhours. Next, each of the three category manhours were divided by cubic inches removed and cubic inches remaining. Then, NC machining manhours were divided by NC tape hours.

These manipulations were performed in order to observe the variation of each manhour category with part characteristics. The mean, the standard deviation and the coefficient of variations were calculated for each category.

The data base for aluminum was quite substantial (Table A-II). It consisted of 31 F-111 designs, each over five pounds in weight. Each of the 31 part numbers had data for an average of 51 pieces, so the sample size was substantial. The data for titanium (Table A-VI) was not nearly as satisfactory. The AMAVS program machined only one piece each of thirteen parts; nevertheless, it was the only data source available for parts large enough to be representative of the types required. The F-111 titanium parts consisted mostly of small fittings, of little use for this purpose.

3.2.2.3 Production Cost Factors

From the data described in 3.2.2.2 factors were developed that would permit the conversion of the tape time and other characteristics computed for each design comparison part into manhours. These manhours would completely reflect all cost contributions in terms of the three cost categories, NC machine time, hand finish time and all other costs. For each of these categories, ratios were calculated relative to tape time, cubic inches removed and cubic inches remaining.

Actual mean NC machine time related best to tape time, as expected. Actual hand-finish manhours related best to cubic inches remaining, also as expected. All other actual time was best related to cubic inches removed, although no rational basis could be found for this.

The production first part cost factors are presented in Appendix A, Table A-III (aluminum) and Table A-VII (titanium). The cost factors derived from these data are summarized below.

Cost Category (1)	Related Function (2)	Cost Factors (1) / (2)	
		Aluminum	Titanium
NC Machine M-H	NC Tape Time	11.435	5.350
Hand-Finish M-H	Cubic Inches Left	0.09830	0.04654
Other Man-Hours	Cubic Inches Removed	0.00883	0.02715

3.2.2.4 Man-Hour Cost Analysis, Comparison Parts

With the comparison part design characteristics and tape times described in 3.2.2.1, the actual cost data described in 3.2.2.2 and the actual cost/production part characteristics relationships developed, as described in 3.2.2.3, the production cost factors could now be applied to the comparison parts to obtain estimated man-hours for each design comparison part. Appendix A, Tables A-IV (aluminum) and A-VIII (titanium) show the results.

3.2.2.4.1 Breakdown of Machine Manhours. The production cost factor for NC machine manhours includes actual machine run time as well as "set-up" time (set-up, cutter changes, tear-down, clean-up). The set-up time is assumed constant for all comparison parts. From production data for aluminum, set-up time was established as 32% of total machine time. For the aluminum baseline part this percentage converts to 2.68 hours which is assumed to be the required set-up time for titanium also. As a result, the set-up time is 12.5% of the total for the titanium baseline part. Thus, aluminum run time is 68% and titanium run time is 87.5%.

3.2.2.4.2 Breakdown of Hand-Finish Time. Hand-finish time was divided into various types based on a survey of the amount and types done on parts similar to the comparison parts. The division was as follows:

De-burr	29%
Surface finish	42%
Tolerance control	29%

Once established, the comparison part configuration differences were allowed to affect hand-finish time only if there was a significant surface area change or if dimensional or roughness tolerances were relaxed.

3.2.2.4.3 Total Cost Data Breakdown. The total manhours for each comparison part were also expressed in manhours per pound and manhours per cubic inch removed, for use in the Design Guideline development, and is presented in Tables A-IV (aluminum) and A-VIII (titanium).

3.2.3 Design Guidelines

Competing design configurations are evaluated in terms of manhour cost and weight by comparing results from Appendix A, Table A-IV for aluminum, and from Table A-VIII for titanium. The data from these tables is assembled and manipulated on Design Analysis Guideline sheets following the above tables. The machining operations are listed, or referenced, and the manhours are given for each. The difference in manhours and the difference in weight are determined, and, finally, the percentage change in total cost and also in total weight as well as, for example, cost saved by not removing the added weight is arrived at.

Each guideline analysis in the Appendix includes an analytical discussion providing the rationale behind the guideline as presented. Also, an explanatory sketch is shown. The final proposed guidelines and the sketches are also shown on the following pages of this section. Separate guidelines are shown for aluminum and for titanium.

The guidelines, for aluminum and titanium, are summarized in Table V.

3.2.3.1 Aluminum Design Guidelines

Figures 10 through 15 and paragraphs 3.2.3.1.1 through 3.2.3.1.3 describe the design guidelines for aluminum pocketed parts.

3.2.3.1.1 Nomograph for Cost Difference Between Two Sizes of Corner Radii. Appendix A contains an extensive analysis of the cost/weight relationships between designing 0.50 inch vs. 0.38 inch corner radii in pocketed aluminum parts. The result was the nomograph seen in Figure 16, enabling a designer to determine fairly easily whether his design should have 0.50 or 0.38 inch corners. The data is based on using a 90% learning curve.

TABLE V DESIGN GUIDELINE SUMMARY

Material	Subject	Guideline Description	% ΔC	% ΔW	Approx. ΔM-H/LB (1st Part)
Aluminum	Flanged vs Vertical Stiffeners	(Use charts in guideline to optimize stiff. config.)	-	-	-
Aluminum	Lands vs No Lands on Pocket Webs	If edge is critical, use lands. Cost is roughly equivalent.	0	(-)10-15	0
Aluminum	Relaxed Tolerance & Radii on Lands	Leave land corner radii as cut by rough cutter, elim. finish cut	(-)3-5	(+)0.3	(-)52
Aluminum	Excessive Height/ Thickness Ratio on Stiffeners	Ratio above 15 requires additional finish passes by cutter; <u>however</u> weight saving is substantial	(+)4-6	(-)5-6	(-)5
Aluminum	Design Permitting Larger Finish Cutters	Design with 0.50" pocket corner radii instead of common 0.38" permits faster metal removal	(-)4-6	(+)1-2	(-)16-17
	Fig. 16 Nomograph for rapid est. of ΔM-H/LB	Determine finish machining length, no. of corners, enter nomograph for cost saving	-	-	-
Aluminum	Reduced H-F due to Relaxed Dim. Tolerance	Relaxing dim. tol. on stiffeners/flanges increases acceptances, reduces dim'l hand finishing	(-)2	(+) 0-0.3	(-)39

TABLE V (cont'd) DESIGN GUIDELINE SUMMARY

Material	Subject	Guideline Description	% Δ C	% Δ W	Approx. Δ M-H/LB (1st Part)
Aluminum	Limit on Stiffener Spacing	Cost avoidance is achieved by limiting stiffener spacing per Table VI for various web thicknesses	-	-	-
Aluminum	Corner Undercuts	Cost avoidance is achieved by allowing a dimensional tolerance of +0.015, -0.020 in pocket corners with a radius of 0.38 or less. Compensate in design if necessary.	-	-	-

TABLE V (cont'd) DESIGN GUIDELINE SUMMARY

Material	Subject	Guideline Description	% Δ C	% Δ W	Approx. ΔM-H/LB (1st Part)
Titanium	Flanged vs Vertical Stiffeners	(Use charts in guideline to optimize stiff. config.)	-	-	-
Titanium	Land vs No Land on Pocket Webs	Despite added cost, if edges are critical lands are cost effective weight savers	(+)6-8	(-)10-15	(+)3
Titanium	Relaxed Tolerance & Radii on Lands	Leave land corner radii as cut by rough cutter, elim. finish cut	(-)8-12	(+)0.3	(-)229
Titanium	Excessive Height/Thickness Ratio on Stiffener	Ratio above 15 requires additional finish passes by cutter; designer must consider trade-off values	(+)9-14	(-)5-6	(+)14
Titanium	Design Permitting Larger Finish Cutters	Design with 0.50" pocket corner radii instead of common 0.38" permits faster metal removal	(-)4-7	(+)1-2	(-)25

SUBJECT: FLANGED VS. VERTICAL STIFFENERS

MATERIAL: ALUMINUM

GUIDELINE: A vertical stiffener up to a maximum height equal to the plate thickness should be used before considering a flanged stiffener. An "L" shaped stiffener will cost 3-4% more, and a "T" shaped stiffener will cost 9-11% more than a vertical stiffener in plates of equal thickness. Only when more stiffness is needed than the vertical stiffener can provide, should a flange stiffener be used.

ILLUSTRATION:

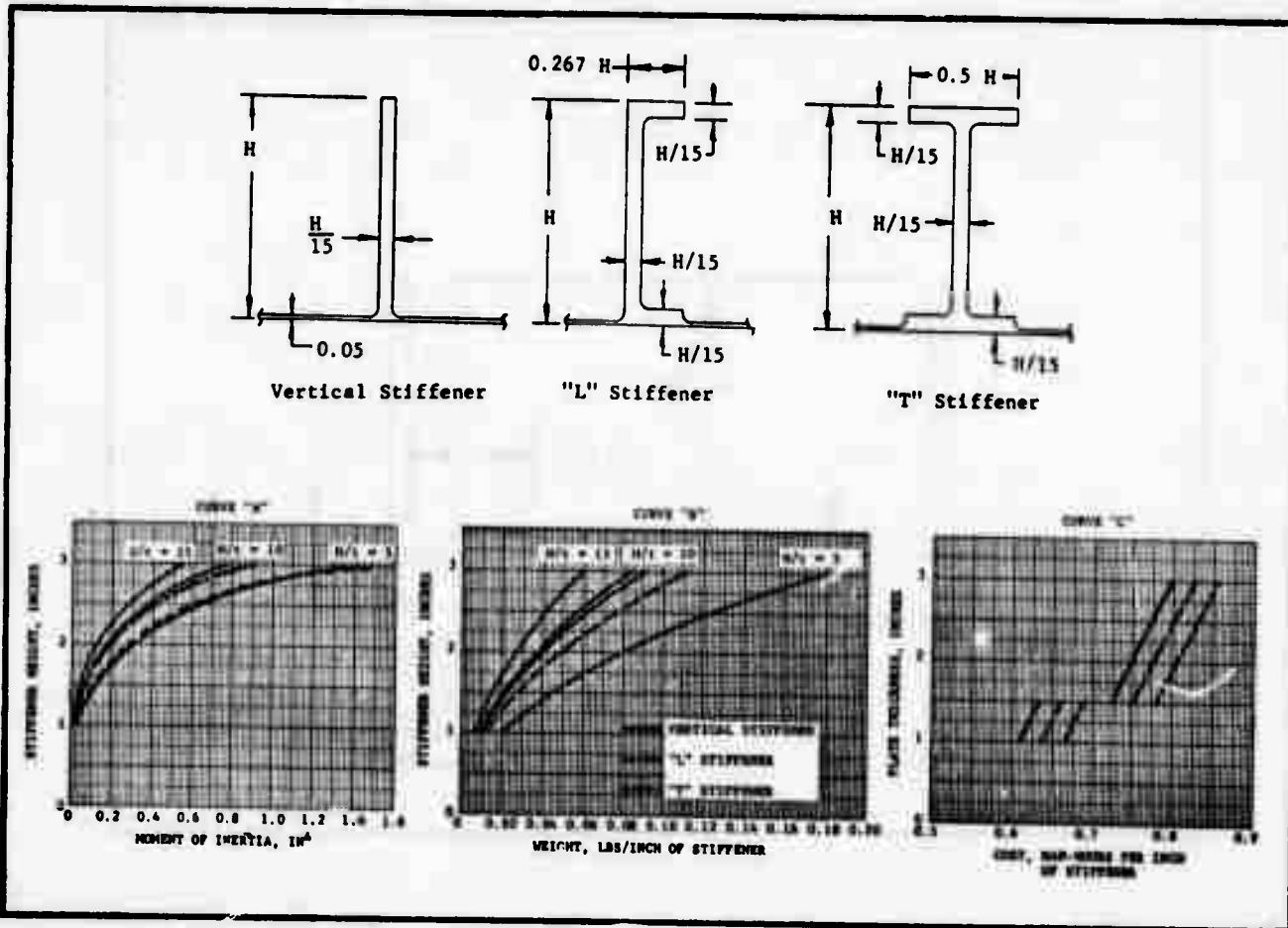

FIGURE 10 DESIGN GUIDELINE - FLANGED VS. VERTICAL STIFFENERS

SUBJECT: LANDS VS. NO LANDS ON POCKET WEBS

MATERIAL: ALUMINUM

GUIDELINE: Edging a pocket with a land is roughly cost equivalent to a web without a land in aluminum. Design should therefore be based on weight and strength rather than cost. If web loads permit, 10-15% weight can be saved by use of a land, at no cost.

ILLUSTRATION:

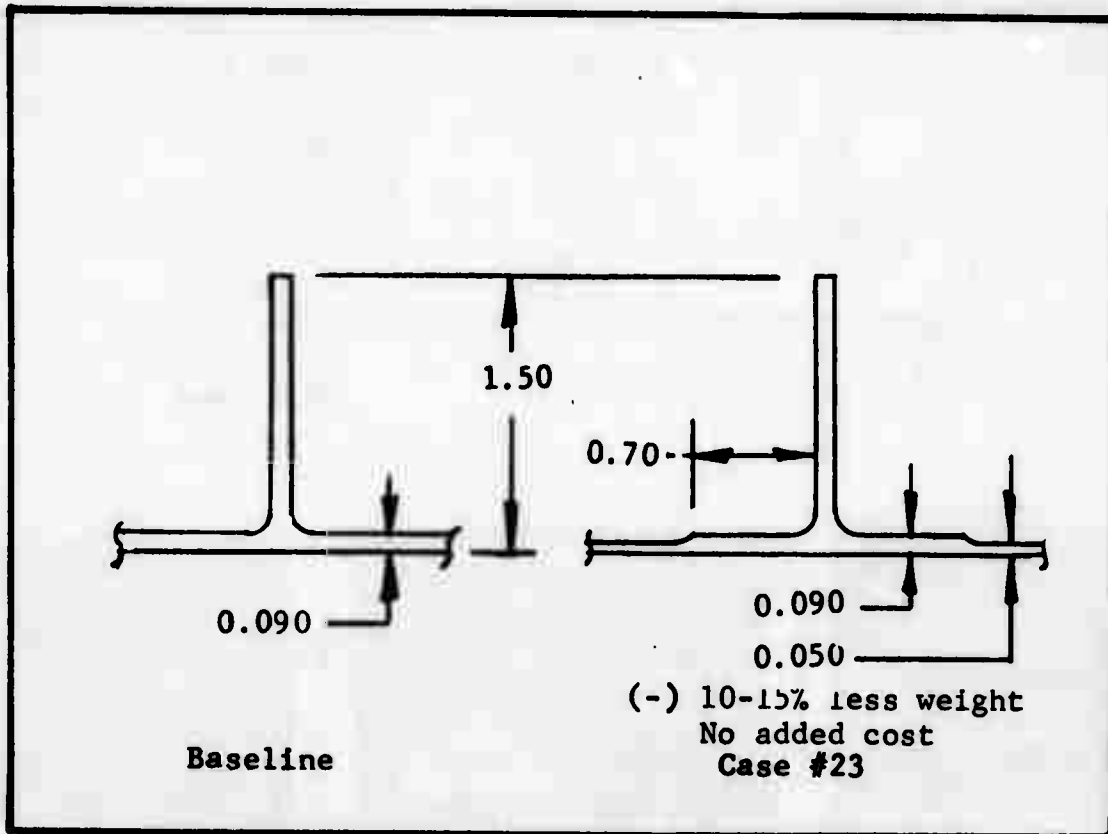

FIGURE 11 DESIGN GUIDELINE - LANDS VS. NO LANDS

SUBJECT: RELAXED TOLERANCES AND RADII ON "LANDS"

MATERIAL: ALUMINUM

GUIDELINE: "Lands" are provided to reinforce the edge of a 0.040-0.050 web. A designer can save 3-5% of the part cost by permitting a 1" land corner radius and a ± 0.06 tolerance on land width rather than the 0.375" R and ± 0.03 " usually required. Cost of avoiding the small weight increase is extremely high.

ILLUSTRATION:

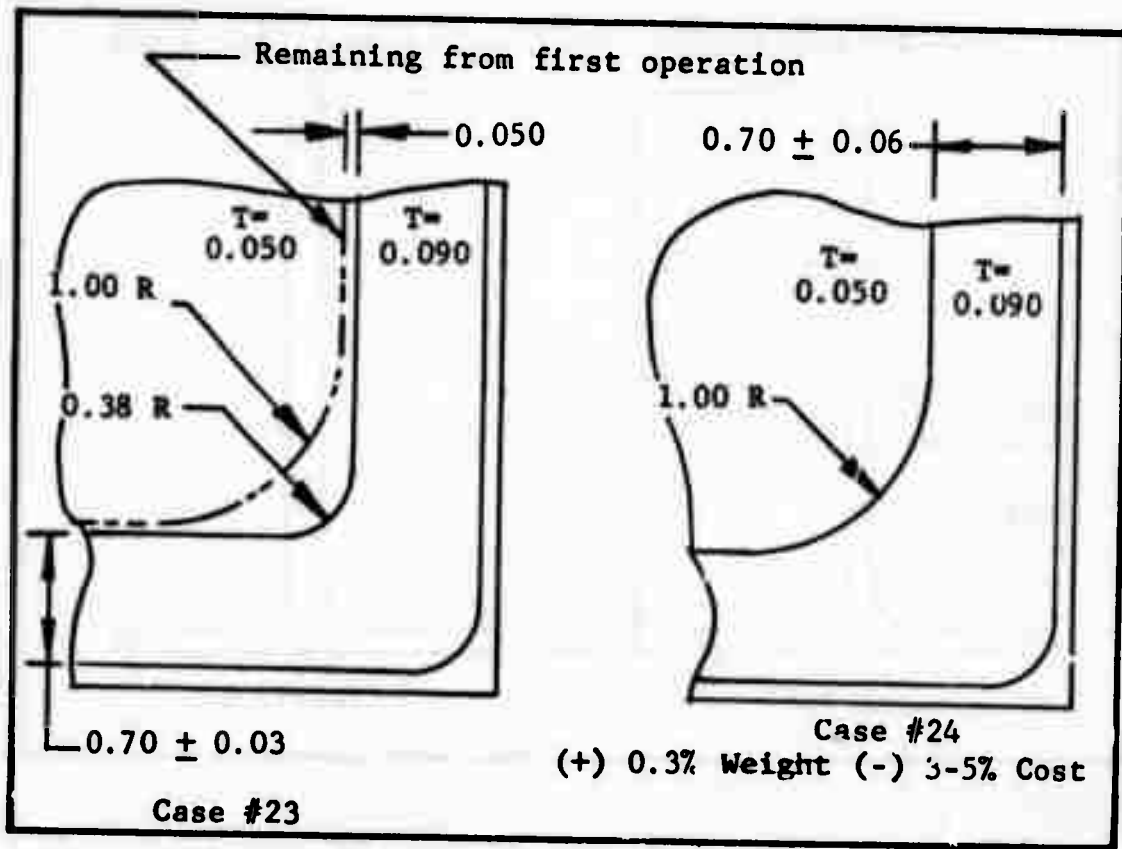

FIGURE 12 DESIGN GUIDELINE - RELAXED WEB-LAND REQUIREMENTS

SUBJECT: EXCESSIVE HEIGHT/THICKNESS RATIO ON STIFFENERS

MATERIAL: ALUMINUM

GUIDELINE: Designing to save weight by use of stiffener height/thickness ratio above 15 increases cost 4-6% due to additional required finish passes by the cutter. Weight saved, however, is 5-6%. The cost rate for removing the weight saved is not higher than that for a typical finish cut.

ILLUSTRATION:

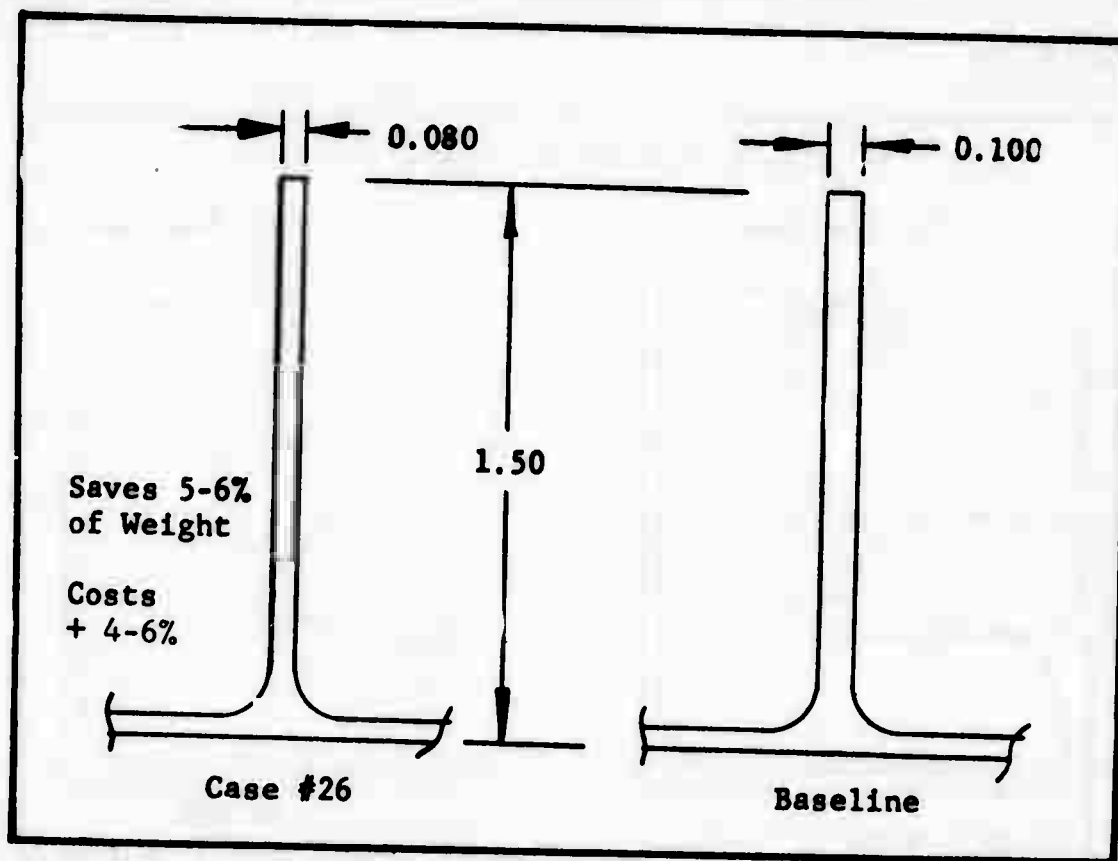

FIGURE 13 DESIGN GUIDELINE - STIFFENER EXCESSIVE h/t

SUBJECT: DESIGN PERMITTING LARGER FINISH CUTTERS
MATERIAL: ALUMINUM

GUIDELINE: Designing pocket corners with a 0.5-inch radius instead of the usual 0.375 permits using a stiffer cutter capable of higher feed rates and fewer passes on the side and corners. Heavier corners increase part weight 1-2%, but cost reduces 4-6%. Avoiding the weight increase requires 15-20 man-hrs/lb., many times the part average rate.

ILLUSTRATION:

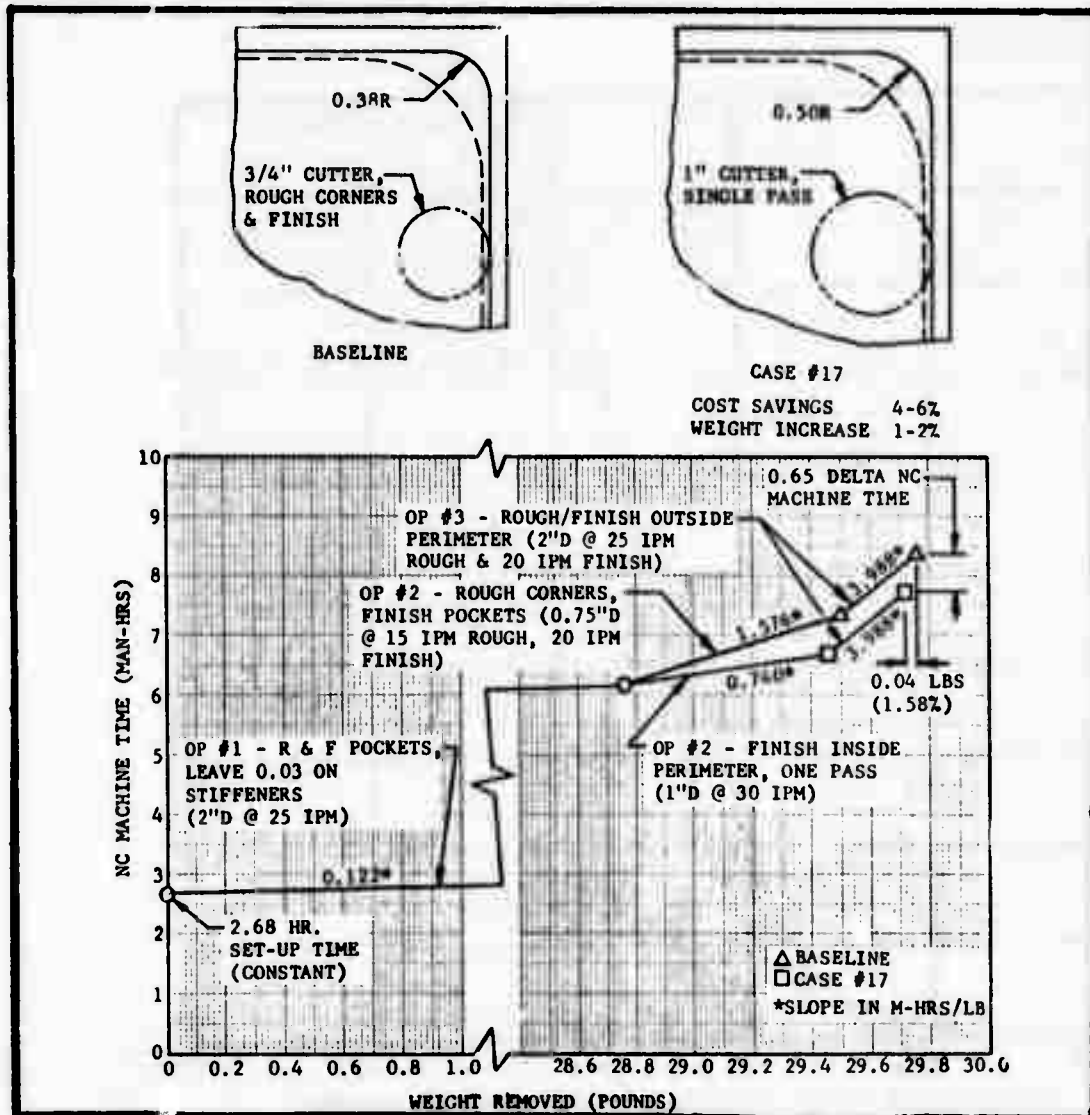

FIGURE 14 DESIGN GUIDELINE - INCREASED POCKET CORNER RADIUS

SUBJECT: REDUCED HAND FINISHING DUE TO RELAXED DIMENSIONAL TOLERANCE
MATERIAL. ALUMINUM

GUIDELINE: It is recommended that dimensional tolerance on aluminum-milled webs be held at the current conventional ± 0.010 and that tolerances on stiffeners and flanges be relaxed to $+ 0.015$, $- 0.010$. This may cause a weight increase of up to 0.3% above current weight but will reduce part total cost by 2%. The cost of avoiding the weight increase is roughly 39 man-hours per pound.

ILLUSTRATION:

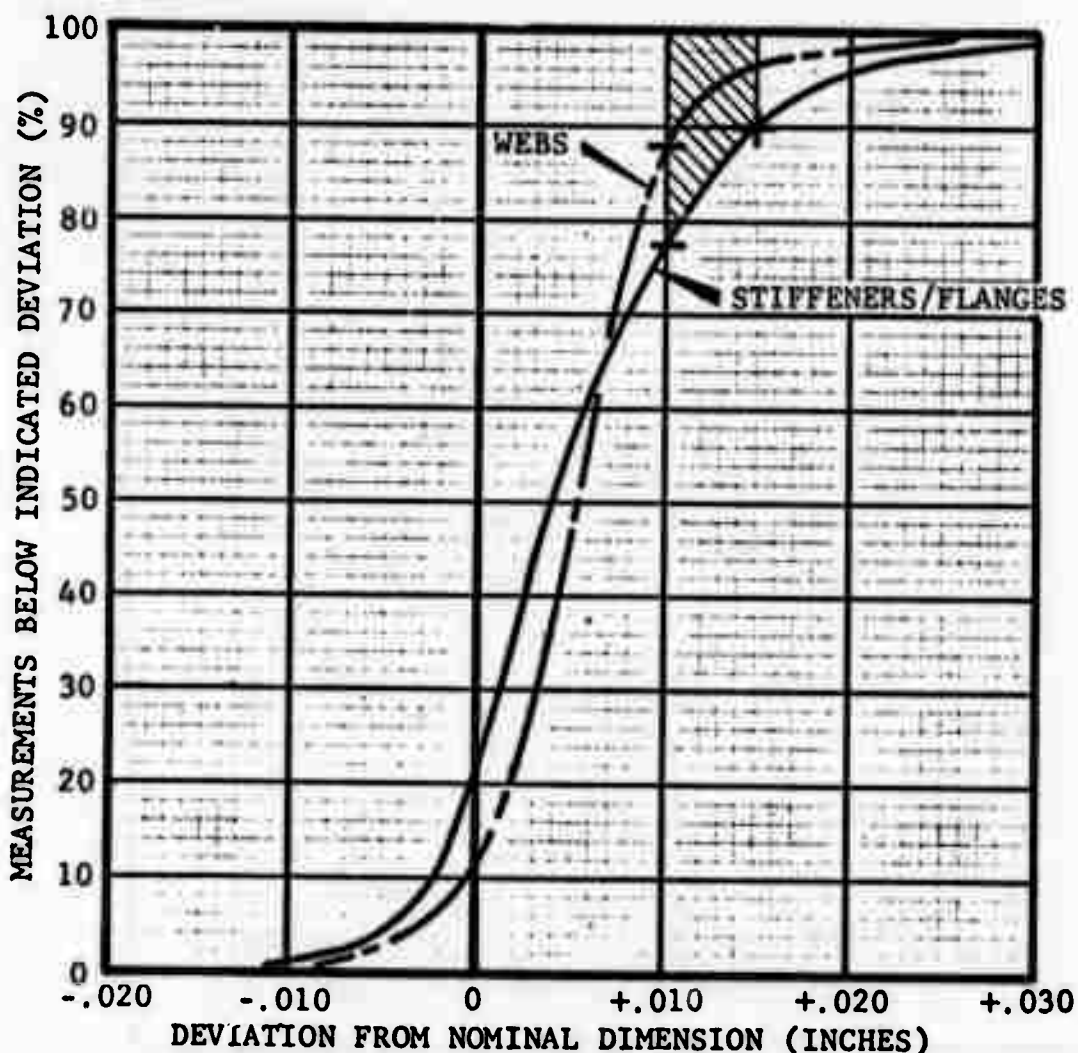

FIGURE 15 DESIGN GUIDELINE - RELAXED DIMENSIONAL TOLERANCE

An approximate cost difference in man-hours per pound between 0.38 and 0.50-inch corner radii can be derived from the chart below. A 0.38-inch radius is considerably more costly to machine. From the overall pocket dimensions, determine L, the total nominal length to be finish-machined, determine the number of corners, N_c , calculate L/N_c and enter the chart to obtain $\Delta C/lb$. If the stiffener height differs from 1.0 or 1.5 inches, ratio $\Delta C/lb$ accordingly.

Fuel tight fastener patterns often require spotface in a corner radius whether 0.38 or 0.50 inch. If 0.38 does not require spotface and 0.50 does, 0.50 radius is not cost effective; nevertheless, 0.50 should be used wherever else possible.

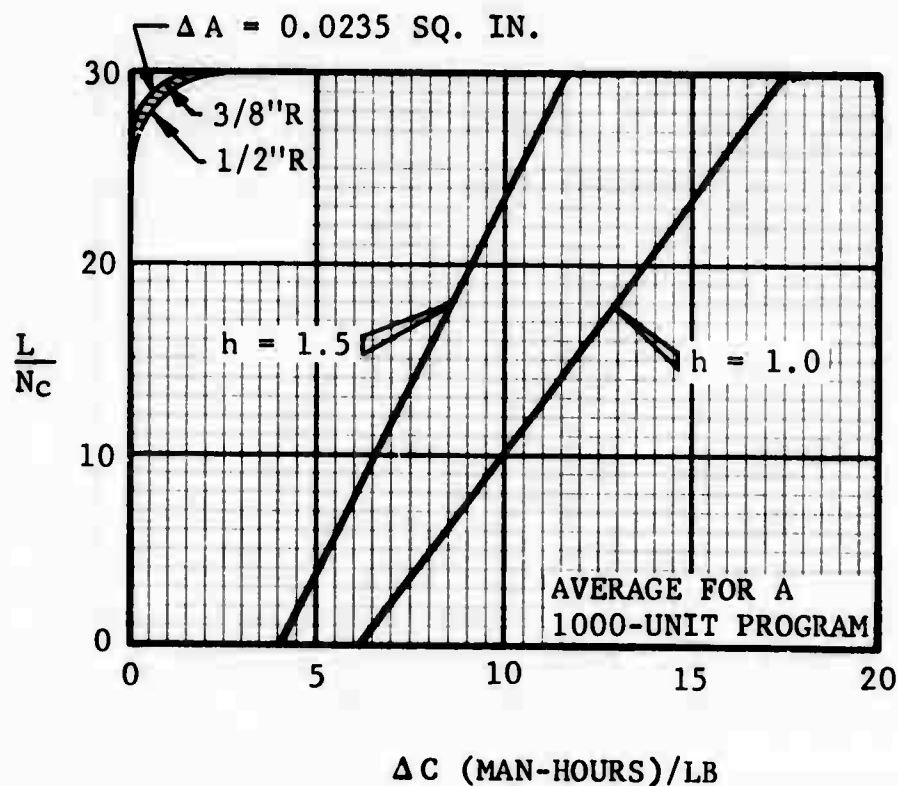

FIGURE 16 NOMOGRAPH - COST DIFFERENCE BETWEEN TWO SIZES OF CORNER RADII

3.2.3.1.2 Limitation on Pocket Stiffener Spacing. Paragraph 3.1.2.2.1 previously referred to charts derived from the factory survey shown in Appendix B that plotted measured thickness deviation from the nominal dimension versus the stiffener spacing, for each of various aluminum web thicknesses. Those plots suggest that machining accuracy would be increased if stiffener spacing were limited for each web thickness. Table VI below is the result of review of the Appendix B data. The F-16 design generally complies with this guideline. Exceeding these spacings will not always result in poor quality, but frequency of occurrences may, however, increase.

TABLE VI
 DESIGN GUIDELINE - MAXIMUM RECOMMENDED CRITICAL PANEL
 DIMENSION VS. WEB THICKNESS
 FOR ALUMINUM

WEB THICKNESS, IN. ± 0.010	MAX. CRITICAL PANEL DIMENSION*, IN.
0.040	5.0
0.045	6.0
0.050	7.0
0.055	8.0
0.060	9.0
0.070 +	9.0

* Critical panel dimension is the smaller dimension of a rectangular panel.

3.2.3.1.3 Design Guideline for Corner Undercut. Another result of the factory survey was recognition of a seemingly unavoidable discrepancy, that of corner undercut. Figure 17 illustrates the problem; however, it is awkward to present such a relaxation directly on a production drawing; consequently, this guideline was incorporated into the hand-finish inspection standard for the F-16 program. This standard is referenced in the drawing notes and thus becomes part of the drawing contents

Design Guideline for Corner Undercuts

A significant cause of rejections in NC and routed finish machining of aluminum with 3/4-inch or smaller diameter cutters is machining a stiffener or flange too thin at the corner of a pocket. This happens to a greater extent in the pocket wall normal to the direction of cutter motion due to machine mass inertia but occurs often on both walls due to vibration during "dwell" while changing direction.

Consequently, it is recommended that all stiffener and flange thicknesses at corners with 0.38 inch radius or less be given an additional - 0.010 inch permissible deviation along the stiffener for a distance equal to the cutter diameter, i.e. in the corner the stiffener thickness tolerance should be $+ 0.015$, $- 0.020$ (see Figure 15). This would have no significant effect on the stiffener function which depends largely on the thickness along the middle portion of span.

Where flange fastener hole spacing and required spot facing fall within the undercut flange area, the designer must consider the effect of the relaxed tolerance and consequent potentially thinner flange on the net flange area.

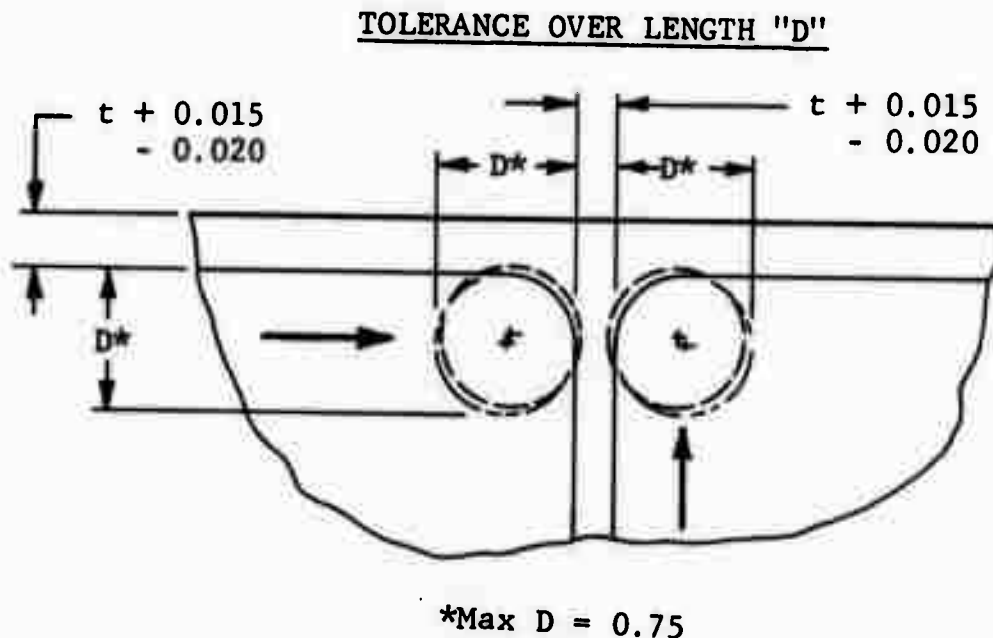

FIGURE 17 DESIGN GUIDELINE - TOLERANCE RELAXATION FOR CORNER UNDERCUT

that must be evaluated by the stress analyst and designer. The cost avoidance involved has not been determined, since the savings are almost entirely in the form of reduced inspection time and paperwork. Such discrepancies are consistently dispositioned "use as is."

3.2.3.2 Titanium Design Guidelines

Figures 18 through 22 describe the design guidelines for titanium pocketed parts. They are generally similar to those for aluminum; however, as one would expect, the drastically lower feedrates and higher material density change the cost/weight relationships substantially from those for aluminum. Generally, the cost reductions are higher since feed rates reduce more than density increases, making application of the titanium guidelines more desirable.

SUBJECT: FLANGED VS VERTICAL STIFFENERS

MATERIAL: TITANIUM

GUIDELINE: A vertical stiffener up to a maximum height equal to the plate thickness should be used before considering a flanged stiffener. An "L" shaped stiffener will cost 7-8% more, and a "T" shaped stiffener will cost 14-16% more than a vertical stiffener in plates of equal thickness. Only when more stiffness is needed than the vertical stiffener can provide, should a flanged stiffener be used.

ILLUSTRATION:

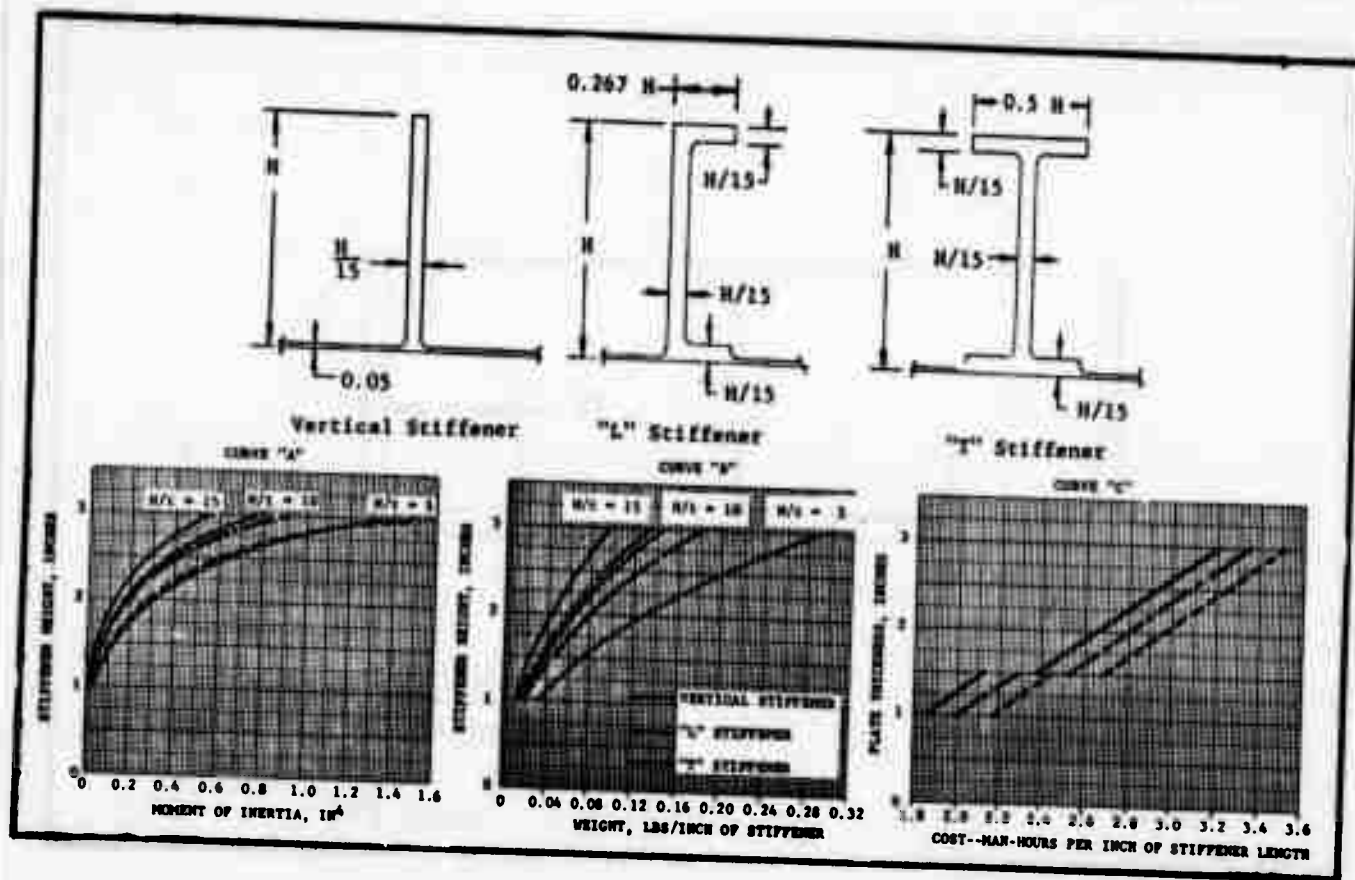

FIGURE 18 DESIGN GUIDELINE - TITANIUM, FLANGED VS. VERTICAL STIFFENERS

SUBJECT: LANDS VS. NO LANDS ON POCKET WEBS

MATERIAL: TITANIUM

GUIDELINE: Where a titanium pocket web thickness is dictated by fuel pressure strength requirements at web edge, the designer must choose between a complete web of the required thickness and a "land" of that same thickness surrounding a thinner web area. The "land" approach is 10-15% lighter and 6-8% more costly for typical cases. The cost rate of additional weight removal is 2-4 man-hours/pound, considerably lower than typical finish machining costs for titanium. Lands should be used when loads permit.

ILLUSTRATION:

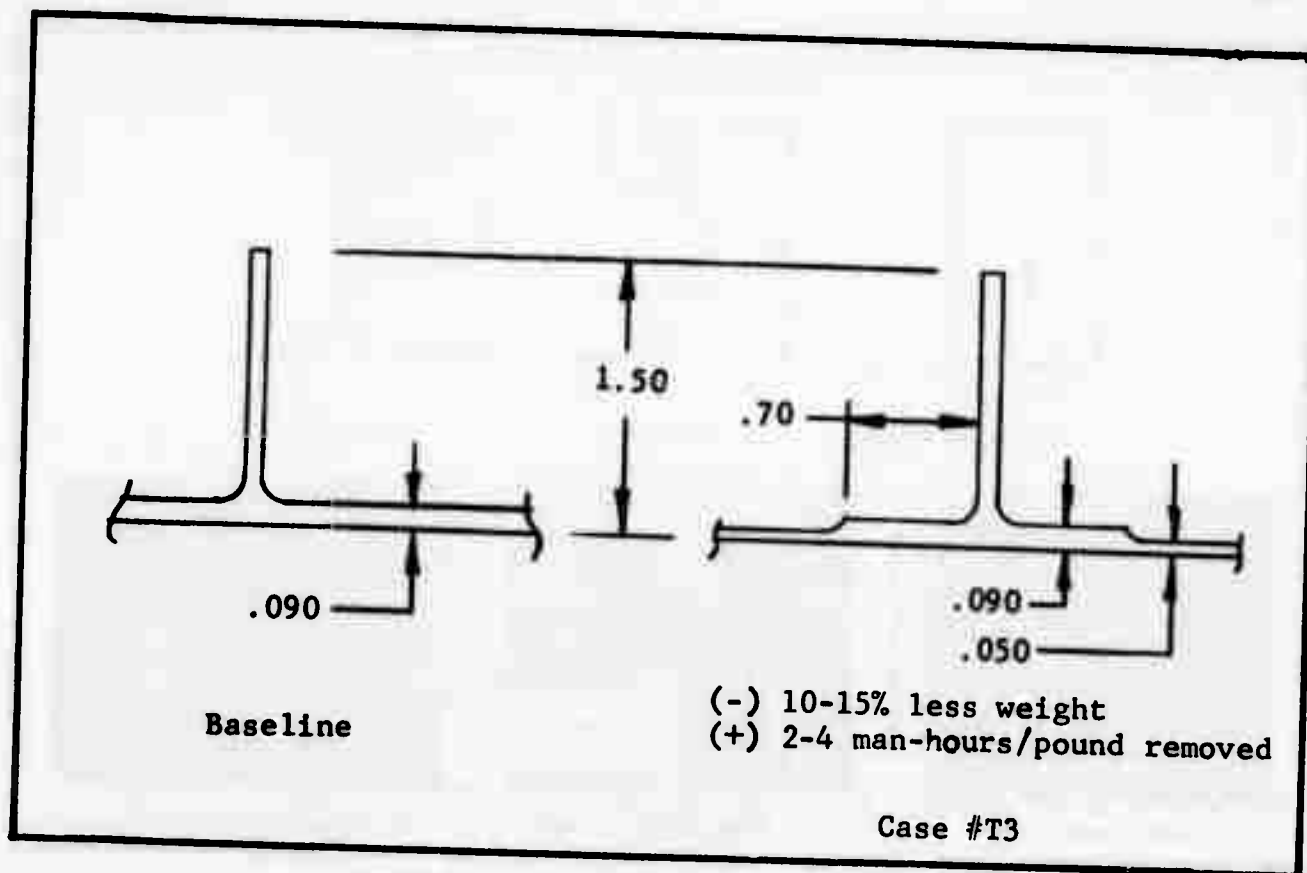

FIGURE 19 DESIGN GUIDELINE - TITANIUM, LAND VS. NO LAND

SUBJECT: RELAXED TOLERANCES & RADII ON LANDS

MATERIAL: TITANIUM

GUIDELINE: "Lands" are provided to reinforce the edge of a 0.040-0.050 web. A designer can save 8-12 percent of the part cost by permitting a 1-inch land corner radius and a ± 0.06 tolerance on land width rather than the 0.38 R and ± 0.03 inch usually required. Weight increases 0.3%. Cost of avoiding the weight increase is extremely high.

ILLUSTRATION:

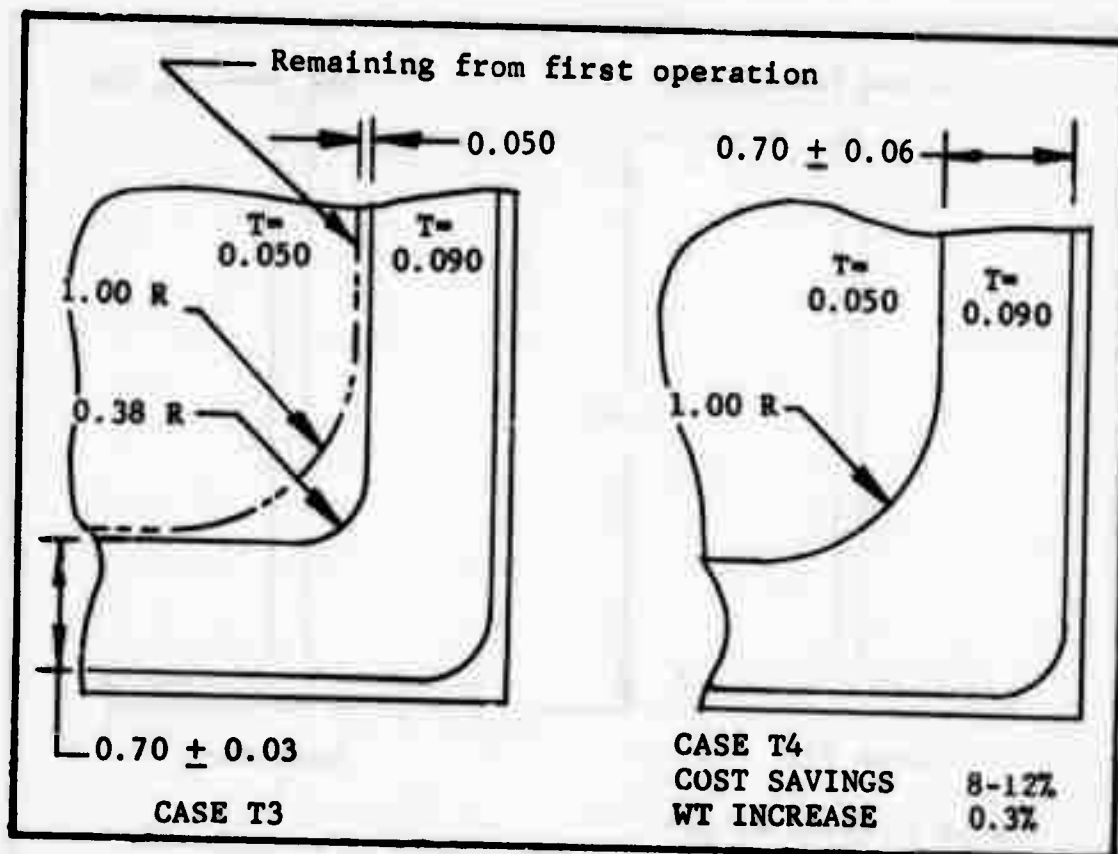

FIGURE 20 DESIGN GUIDELINE - TITANIUM, RELAXED WEB-LAND REQUIREMENT

SUBJECT: EXCESSIVE HEIGHT/THICKNESS RATIO ON STIFFENERS

MATERIAL: TITANIUM

GUIDELINE: Designing to save weight by use of stiffener height/thickness ratio above 15 increases cost 9-14 percent due to additional required finish passes by the cutter. Weight saved, however, is 5-6 percent for a typical case.

Weight avoidance costs roughly 14 man-hours/lb, compared with typical finish cost of 6-7 man-hours/lb.

ILLUSTRATION:

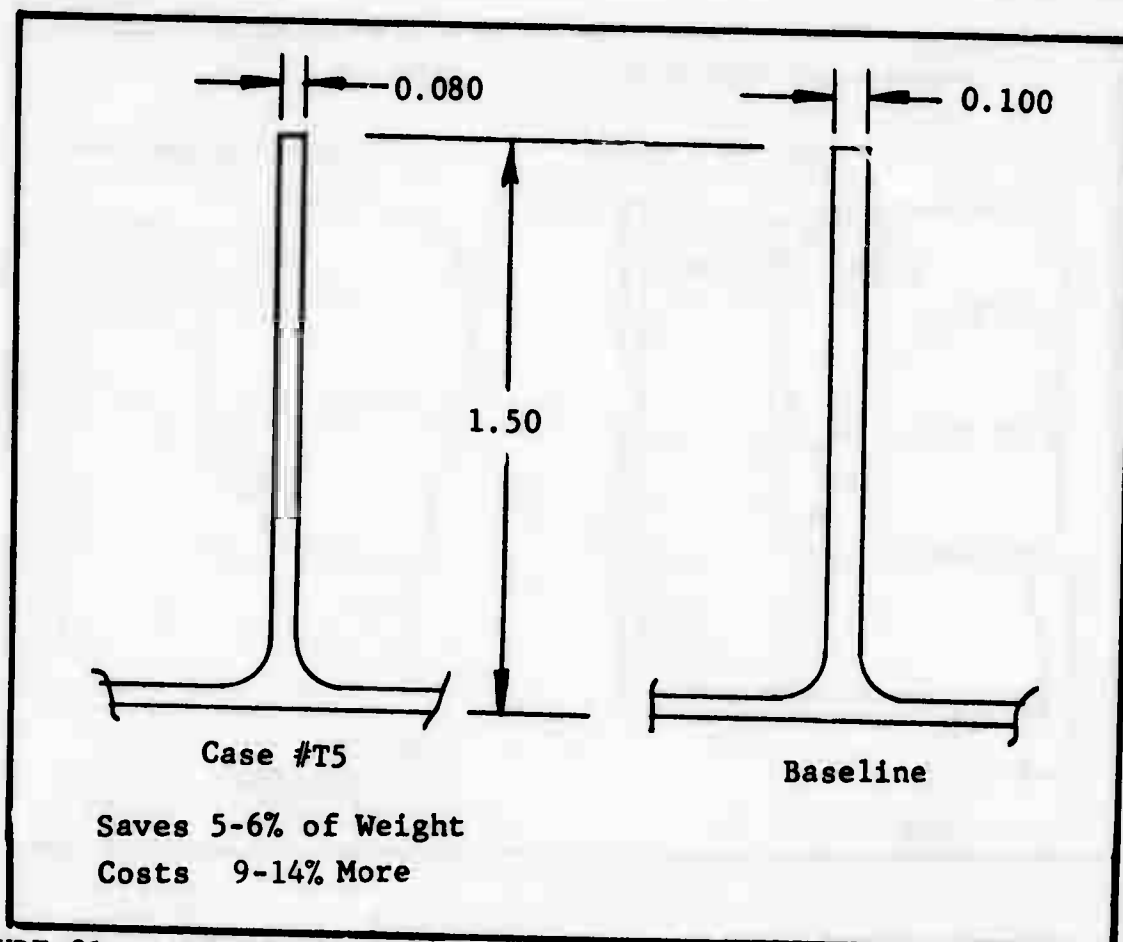

FIGURE 21 DESIGN GUIDELINE - TITANIUM, STIFFENER, EXCESSIVE h/t

SUBJECT: DESIGN PERMITTING LARGER FINISH CUTTERS

MATERIAL: TITANIUM

GUIDELINE: Designing pocket corners with a 0.5 inch radius instead of the usual 0.38 radius permits using a stiffer cutter capable of higher feed rates and fewer passes on the sides and corners. Heavier corners increase part weight 1-2%, but cost reduces 4-6%. Avoiding the weight increase costs 25 manhours per pound.

ILLUSTRATION:

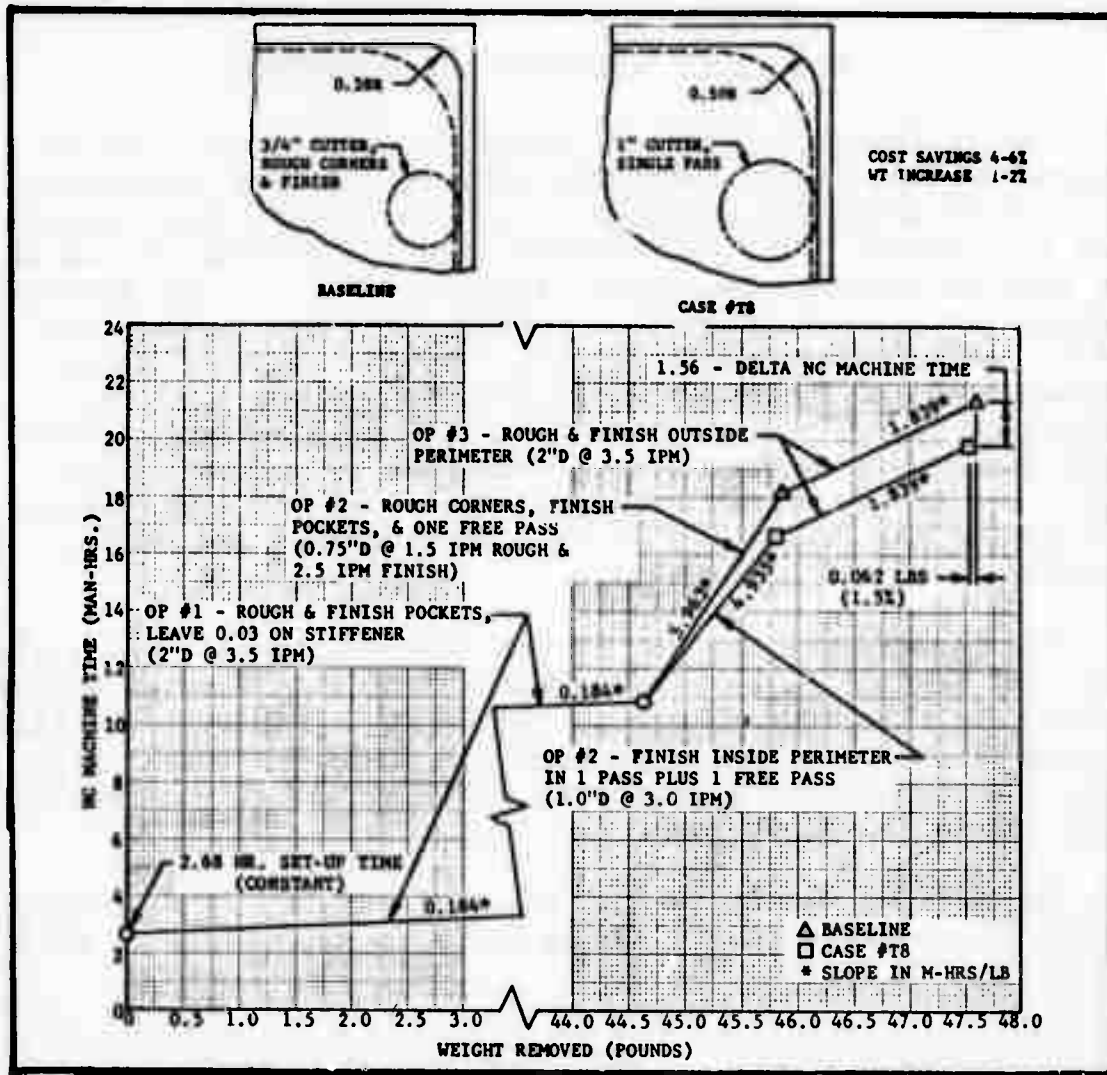

FIGURE 22 DESIGN GUIDELINE - TITANIUM, INCREASED POCKET CORNER RADIUS

4. SURFACE ROUGHNESS AND HAND - FINISHING

One major program objective was to evaluate the present AFSC Design Handbook 2-1 requirement for control of measured roughness on fatigue-critical parts. This requirement causes extensive, costly hand-finishing on airframe parts throughout the industry. RTC contract scope required that this subject be explored by testing of specimens that fully represented aircraft components in detail design and manufacturing processes. This section describes how this objective was achieved.

4.1 TEST DESCRIPTION AND HISTORY

The objective of the test program, as proposed, was to design specimens fully representative of airframe components in terms of geometric configuration, manufacture these specimens in a manner fully representative of production processes, and test in a manner reasonably representative of the aircraft environment. The test program consisted of two tasks. One was to conduct development tests to provide evidence as to whether measured roughness is related to fatigue life, by testing at aircraft spectrum stress levels to generate cracks which would be prevented from propagating by polishing out. When a sufficient number of cracks was generated, correlation of location and frequency, if any, to roughness and hand-finishing would be analyzed.

The second task was to provide verification of the development test results by testing actual aircraft production parts to the same spectrum and stress levels until the aircraft life demonstration requirement had been experienced. These tests would then constitute a realistic verification of the results hoped for in the first task.

The design, manufacturing, and test history is described herein. A complete record can be found in Appendices C, D, E and F.

4.1.1 Design and Analysis of Development Test Specimens

The development test specimens are I beams designed to be representative of typical, integrally machined and fatigue-critical airframe components. The I beam design, consisting of pockets on each side, permits typical NC programming and machining techniques for duplication of common dimensional deviations, surface finish, cutter mismatches, tool marks, etc. that normal production parts experience.

Specimens were designed in 2124-T851 aluminum and 6Al-4V beta annealed titanium, identical except for web and flange thicknesses. The stress analysis task was to design specimens that were structurally stable for possible unsymmetrical alignment of ram loads and yet would produce the desired stress level within ram load capacity. Aluminum I beams were designed without and also with a 1/4 inch typical fastener hole pattern. These are illustrated by Figures 23 and 24. The titanium beam is shown in Figure 25.

The beams were 6 inch by 2.88 inch in cross-section, 54 inches long with a 30 inch test section with six 1.3+ inch deep pockets. Corner radii were a typical 0.375 inches. A 12 inch segment on each end served to introduce the loads. The outboard pockets were intended to transition the ram loads into the test section. Dimensional details can be obtained from Figures C-1 and C-2 of Appendix C. Drawings called for hand-finishing from the span midpoint to one end, leaving the other half span as machined.

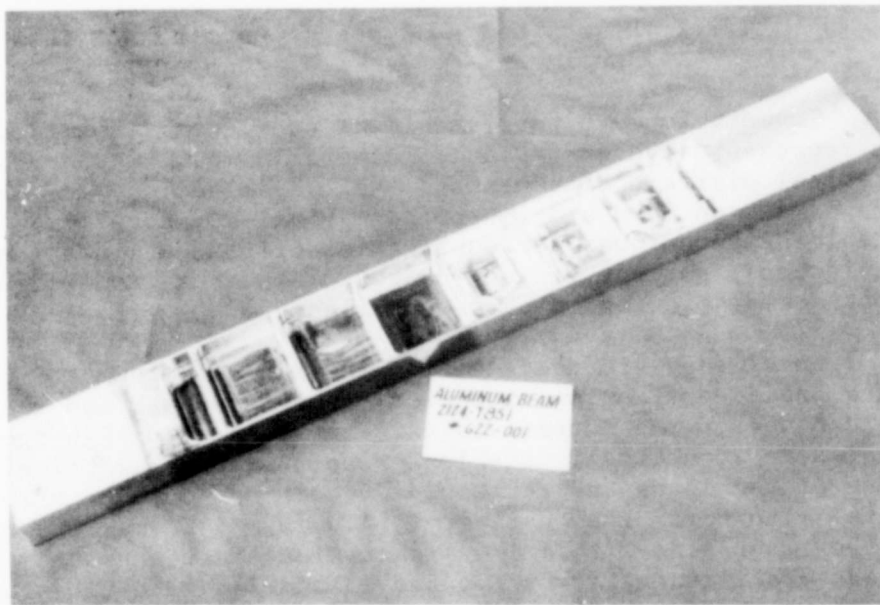

FIGURE 23 ALUMINUM I-BEAM FATIGUE TEST SPECIMEN

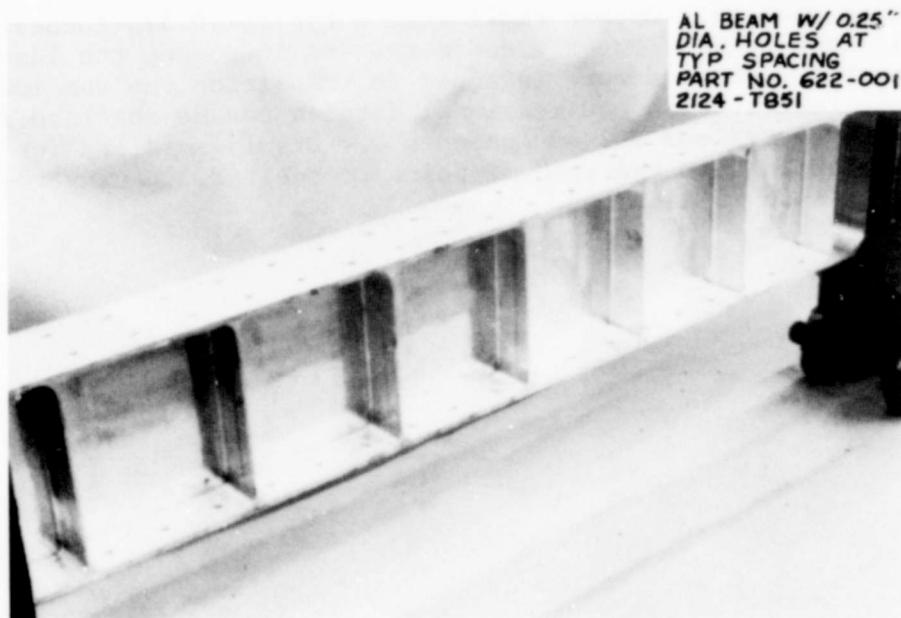

FIGURE 24 ALUMINUM I-BEAM WITH 1/4" FASTENER HOLES

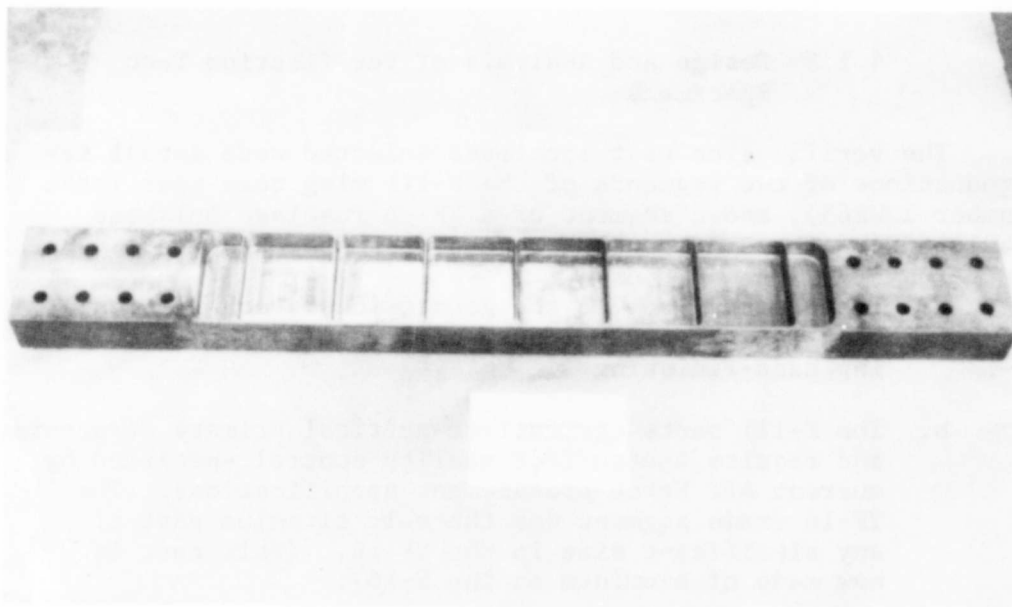

FIGURE 25 TITANIUM I-BEAM FATIGUE TEST SPECIMEN

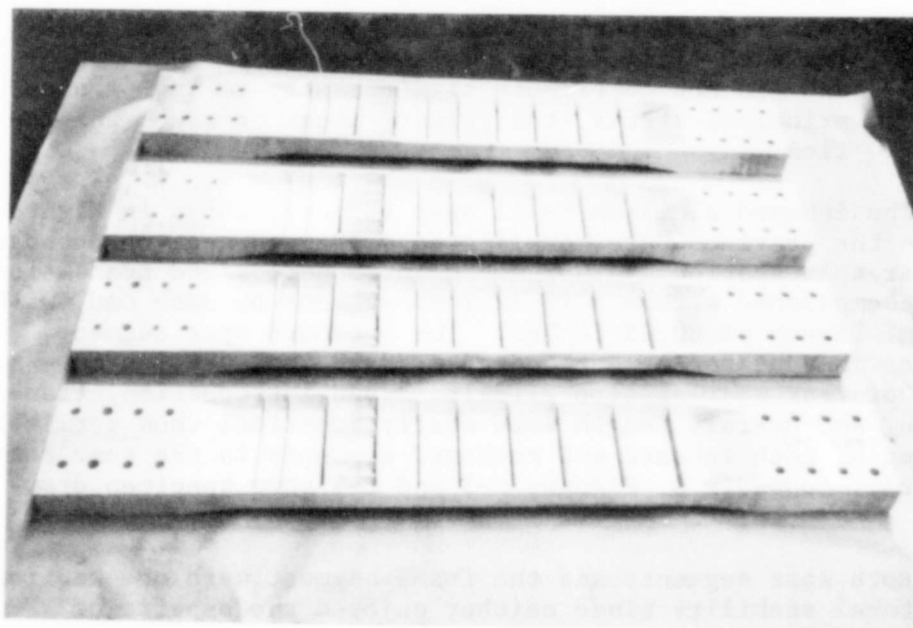

FIGURE 26 F-111 REAR SPAR INBOARD TEST SPECIMENS

4.1.2 Design and Analysis of Verification Test Specimens

The verification test specimens selected were actual reproductions of two segments of the F-111 wing rear spar (part number 12W865), and a segment of a YF-16 fuselage bulkhead (401B2692). These components were selected because:

- a. These parts provide the geometric characteristics that lead to typical surface irregularities requiring hand-finishing.
- b. The F-111 parts are fatigue-critical primary structure and require the surface quality control specified by current Air Force procurement specifications. The YF-16 frame segment was the only titanium part of any significant size in the YF-16. (This part is now made of aluminum on the F-16).
- c. The nature of the wing loading on the spar segments in the aircraft was such as to enhance test fixture design in that, over the short span of these parts, the F-111 wing bending moment was nearly constant. This feature permitted equal and opposite ram loading with little error. Also, spar shear was low and did not contribute significantly to spar flange principal stress, the primary cause of crack initiation.

The inboard aluminum F-111 spar segment, shown in Figure 26 on the previous page, duplicated a 30 inch section outboard of rear spar station 143.40. Load introduction and transition was accomplished within a 15.12 inch segment on each end, with a total length of 60.25 inches. The outboard spar segment, similar in appearance, duplicated a 28.18 inch section outboard of rear spar station 211.716. Load introduction, transition, and overall length were nearly identical thus permitting testing of both inboard and outboard segments in the same test fixture. Appendix C, Figures C-3 and C-4 show specimen drawings.

Both spar segments and the frame segment were checked for structural stability since neither enjoyed the benefit of attachment to adjacent skins in the test fixtures.

4.1.2 (Cont'd.)

The frame, shown in Figure 27, is part of an assembly of two channels back to back held together by the skin and cover plates. The vertical tail loads are introduced by two bolts near the centerline. In the aircraft, the ends are bolted to the lower bulkhead segment with a multiple bolt pattern which provide a convenient attach point for the test fixture.

The YF-16 titanium frame eventually presented a difficult predicament. The design was a result of prototype expediency. It probably did not need to be titanium but was made in titanium in order to provide insurance against excessive vertical tail loads during the prototype test programs. Consequently, the highest frame spectrum stresses were found to be little higher than that which aluminum could tolerate. Increasing the stresses to the levels representative of titanium would have created load introduction problems as well as questions on YF-16 structural integrity if a premature failure should occur. Finally, the test proceeded as planned since no feasible alternate titanium production part existed.

Appendix C, Figure C-5 shows a specimen sketch.

4.1.3 Manufacturing of Test Specimens

Eighteen I beams were fabricated, twelve in aluminum and six in titanium. Four aluminum beams had fastener holes drilled in each flange representing a typical fastener pattern, using current production practice and quality criteria. Eight spar segments were manufactured, four inboard and four outboard representations of the F-111 rear spar. One assembly of the YF-16 frame was fabricated.

All the I beams and spar segments were machined with typical NC programming on milling machines maintained to established specifications and considered as average in condition. Only sharp cutters were used, however, so as to eliminate variables due to cutter dullness. Specifications for the cutters and NC machines are presented in Appendix C.

The YF-16 titanium frame segments were machined from a pattern on a conventional profile mill in the same manner that the prototype parts were machined.

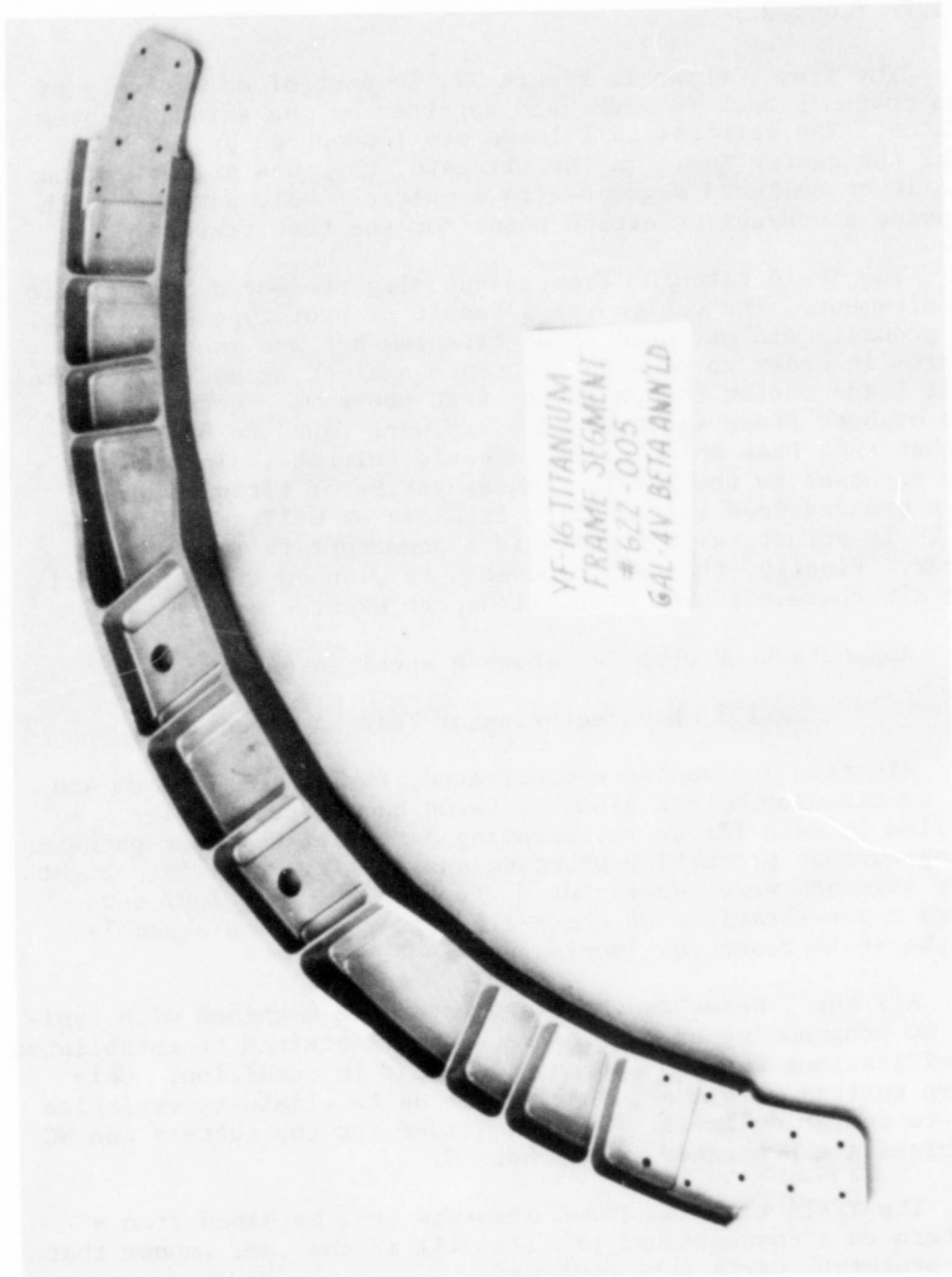

FIGURE 27 YF-16 TITANIUM FRAME TEST SPECIMEN

4.1.3 (Cont'd.)

Standard milling rates normally produce as-machined surfaces well within conventional roughness limits. In an attempt to produce a rougher as-machined surface, feed rates for the aluminum I beams were doubled. Despite the increase in metal removal rates, surface finish was generally far better than required.

De-burring on all specimens was done with a file instead of the usual scraper in order to provide additional protection against machining burrs that could initiate cracks and cause premature loss of specimens.

4.1.3.1 Selective Hand-Finishing on Test Specimens

The eighteen I beams were hand-finished over the entire surface of one half of the span. The other half, from the mid-span outboard, was left in the as-machined, de-burred condition. There was no deliberate attempt to achieve a given measured roughness, but merely to achieve a sufficient contrast in roughness, compared to the as-machined condition, through hand-finishing. By this approach, a constant load along the beam would stress each type surface identically.

The spar segments were paired. One of each pair was left as-machined and the other was completely hand-finished. Thus, the four inboard specimens were paired in the same test fixtures, each of the two pairs loaded by the same rams, thereby insuring identical loads on both as-machined and hand-finished specimens. The four inboard and the four outboard specimens were treated in the manner described.

The curved titanium frame segments were hand-finished over all surfaces on one side of the frame centerline, leaving the other half as-machined. An alternative was to hand-finish one channel completely and the other not at all; however, since the two back-to-back channels were not quite identical due to aircraft contour and since the vertical tail load spectrum was symmetrically applied, relative to left and right, the above hand-finishing approach was used.

Hand-finishing was done primarily with a hand-held, air-powered disc sander but occasionally by hand, using grit paper. Both methods are standard shop practice.

4.1.3.1 (Cont'd.)

Surface roughness was measured with a digital profilometer. Measurements on the I beams were oriented to a location reference system to facilitate communication and record keeping. Measurement data on all specimens is presented in Appendix C.

4.1.4 Test Fixtures and Loading

Test spectra were applied with computer controlled rams for all specimens. Frequency of loading was set as high as possible, limited by hydraulic flow capability. Load level for each spectrum load was controlled with a closed loop electrohydraulic servo, with a load cell feedback closing the loop.

4.1.4.1 I Beam Test Set-Up

The I beams were tested in a frame (Figure 28), four at a time. Two rams per beam applied a constant load along the entire length of each flange, one in tension and one in compression, thereby effectively applying a constant bending moment along the beam. Thus, each flange had the same stress along the entire test section span. The remaining conditions that could cause crack initiation would then be the surface finish, material properties, or the manufactured geometric stress concentrations, or a combination of these.

Before testing began, a strain survey was conducted on the first aluminum I beam to verify the adequacy of the test fixture and load introduction. Eighty channels for strain gages were installed, pictured in Appendix E, Figure E-5. The results are shown in Table E-1. The objective was to achieve the nominal stress $\pm 5\%$ along the length of the beam flange, and this objective was generally achieved.

The remaining 17 I beams were checked for ram load alignment and flange internal stress symmetry with eight strain gages, as shown in Appendix E, Figure E-5. Readings for each beam are listed in Table E-V. Adjustments were provided to achieve ram load symmetry.

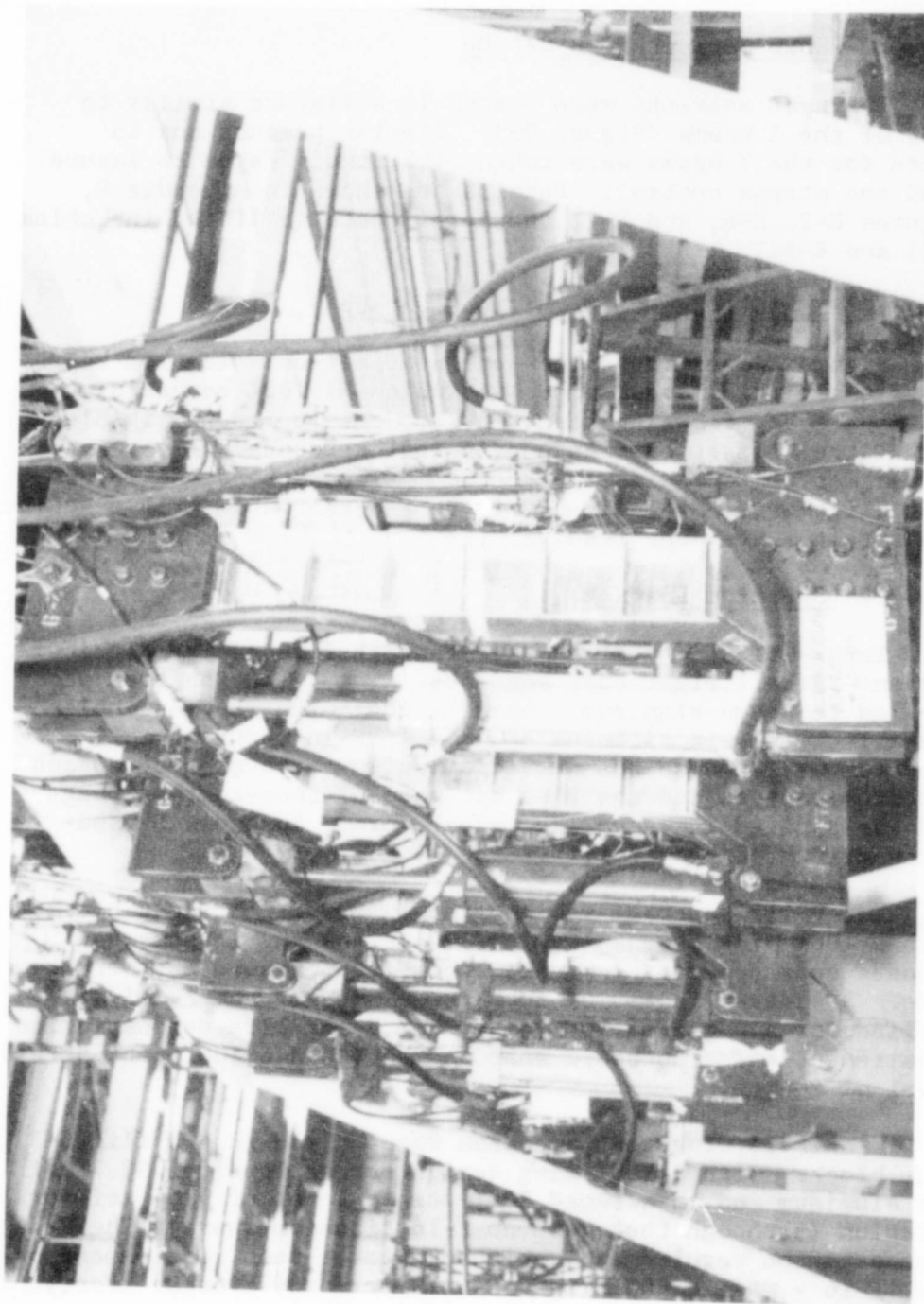

FIGURE 28 I-BEAMS IN TEST FIXTURE

4.1.4.2 Spar Segment Test Set-Up

The spar segments were tested in a fixture similar to that of the I beams (Figure 29). Similar precautions to those for the I beams were taken with strain gages to insure load and stress control. Details are shown in Appendix E, Figures E-2, E-6, and E-7, and strain data is listed in Tables E-II and E-III.

4.1.4.3 YF-16 Titanium Frame Test Set-Up

Figure 30 best describes the test set-up. The ram represents the vertical tail side load which is 100% reversible. Fuselage shear flows to the skin were considered negligible, with little effect on flange principal stresses. A strain survey was conducted to locate the maximum stress and insure load alignment. Appendix E, Figure E-8 and Table E-IV describe the strain survey and results.

4.1.4.4 Spectrum Loading

The F-111 spectrum was used to test five of the aluminum I beams and all eight spar segments. The YF-16 spectrum was applied to seven aluminum I beams - four with fastener holes - and all of the six titanium beams. A YF-16 vertical tail spectrum was used on the curved titanium frame segment. Each spectrum represented the best estimate of then-current usage and was applied in randomized block form. Appendix D tabulates all three spectra.

The F-111 spectrum was applied in 200 flight-hour blocks with a 100% wing stress level of 24 ksi on the I beams and inboard spar segments. Twenty blocks represented one service life. A scatter factor of four, required for the F-111, was applied for a total of 80 blocks, the F-111 life demonstration requirement. The outboard spar segments had a 100% test stress level of 28 ksi.

The YF-16 wing test spectrum was applied in 400 flight-hour blocks, with a 100% wing design stress level of 30.7 ksi for aluminum and an assumed 100% stress level of 61.4 ksi for titanium (although there are no F-16 titanium spars). The F-16 demonstration requirement - although not a test requirement on the YF-16 - was 16,000 flight hours, or forty blocks. Forty blocks was two F-16 lives.

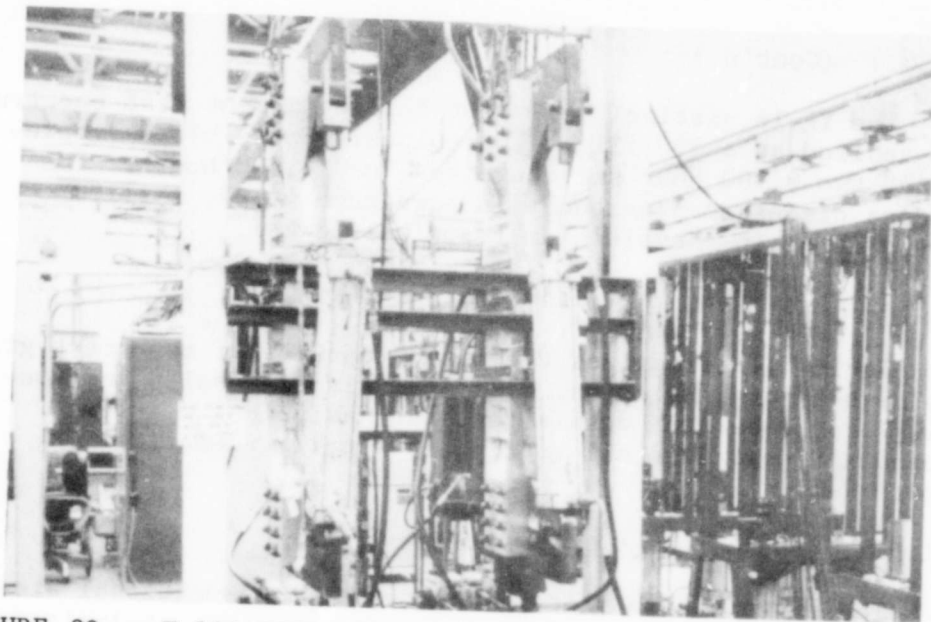

FIGURE 29 F-111 REAR SPAR SPECIMENS IN FATIGUE TEST FIXTURE

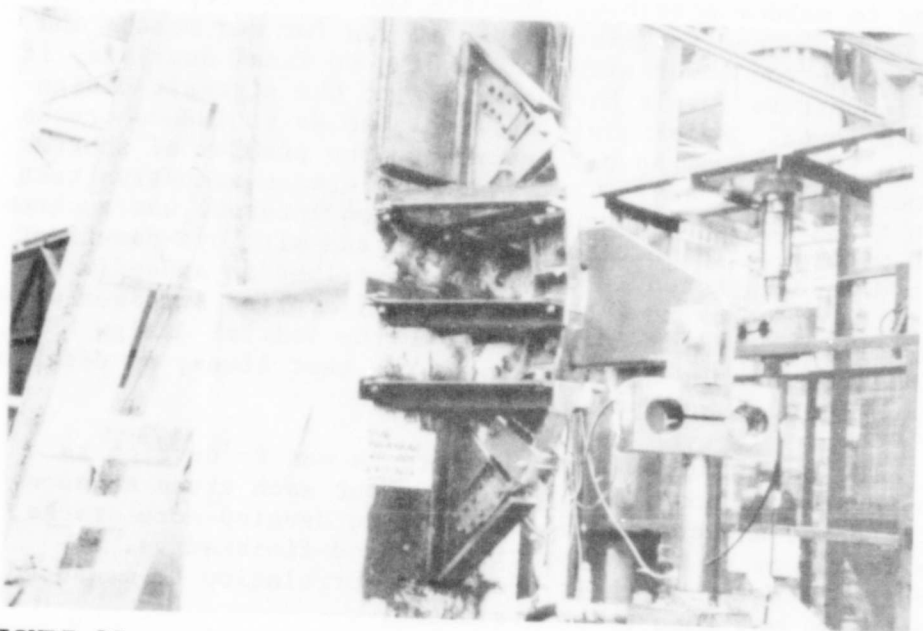

FIGURE 30 YF-16 TITANIUM FRAME IN FATIGUE TEST FIXTURE

4.1.4.4 (Cont'd.)

The YF-16 vertical tail root rolling moment test spectrum was applied as a 400 flight hour block. Forty blocks represented two 8,000 hour service lives, or 16,000 hours. For reasons discussed previously in paragraph 4.1.2, the 100% stress level in the titanium frame was 38 ksi.

4.1.5 Test History

Table VII summarizes the basic features of each test group. The next major subsection, 4.2, Analysis of Results and Conclusions, tabulates detail test and analytical results. Appendix F describes all testing in detail, summarized in Figure F-1.

4.1.5.1 I Beam Test History

The extreme durability encountered in conventional aircraft components with no fastener holes or other equivalent, severe stress concentrations - despite the absence of hand-finishing - was totally unanticipated since design without holes is seldom possible. Whereas the I beam test program had been planned for six months, it ran for ten months and would have run indefinitely according to final analysis, if applied stress levels had been left at the aircraft design stress level. Raising stress levels so as to induce cracks within the program span-time created the problem of shorter inspection intervals. The "squeeze" between excessive test span time versus an adequate inspection interval was a chronic test problem. Inspection was visual and with dye penetrant to a demanding schedule typically described in Appendix E, Table E-VI. Upon test completion, all applied stresses were "normalized" by fatigue analysis to the initial design MSSL, with corresponding adjustments to the test lives, as described in section 4.2 and Appendix G.

The objective of the I beam tests was to develop as many cracks as possible by grinding out each crack as soon as detected and continuing the test to develop more cracks. The frequency of crack location in hand-finished vs. as-machined areas, and their frequency correlation to measured roughness, was then to be evaluated.

TABLE VII COMPONENT TEST PROGRAM SUMMARY

SPECIMEN	PART NO.	MATERIAL	NO. OF SPECIMENS	LOAD SPECTRUM	SURFACE FINISH AND MAJOR FEATURE
I-BEAM	622-001	2124-T851 ALUMINUM	5	F-111A PHASE I AND II TRAINING USAGE	HALF SPAN AS-MACH'D (A-M) HALF SPAN HAND-FIN. (H-F) NO FASTENER HOLES
I-BEAM	622-001	2124-T851 ALUMINUM	3	YF-16 AIR SUPERIORITY RANDOM ORDERED	(SAME AS ABOVE)
I-BEAM	622-001	2124-T851 ALUMINUM	4	(SAME AS ABOVE)	HALF SPAN A-M HALF SPAN H-F $\frac{1}{2}$ " FASTENER HOLES @ 1 5/8" SPACING, TWO ROWS/FLANGE
I-BEAM	622-002	6 A1-4V b.a. TITANIUM	6	(SAME AS ABOVE)	HALF SPAN A-M HALF SPAN H-F NO FASTENER HOLES
F-111 REAR SPAR SEGMENT (INBOARD)	622-003	2124-T851 ALUMINUM	4	F-111A PHASE I AND II TRAINING USAGE	L/R AS-MACHINED L/R HAND-FINISHED NO FASTENER HOLES
F-111 REAR SPAR SEGMENT (OUTBOARD)	622-011	7050-T73651 ALUMINUM*	4	(SAME AS ABOVE)	(SAME AS ABOVE)
YF-16 BULK-HEAD SEGMENT	622-005	6 A1-4V b.a. TITANIUM	1 ASSY (2 PCS)	YF-16 VERT. TAIL AIR SUP., RANDOM ORDERED, MODIFIED	HALF SPAN A-M HALF SPAN H-F NO FASTENER HOLES

* NOT SAME AS F-111 PRODUCTION MATERIAL

4.1.5.1.1 First Failure in Transition Bay. Testing began on three beams at the maximum spectrum stress level (MSSL) of 24,000 psi for the F-111 spectrum. After 80 blocks (F-111 requirement) without detectable cracks, the MSSL was increased to 45,000 psi in order to accelerate crack initiation. Testing continued until an unexpected catastrophic failure occurred in the outboard pocket - the transition area - of one beam. A strain survey revealed that the stress at the pocket corner large radius tangent point was 35% higher than the nominal stress throughout the rest of the beam flange.

4.1.5.1.2 Transition Bay Reinforcement. In order to prevent future premature failures and thus compel crack initiation where desired, doublers were bonded on the flange effectively increasing local flange area and improving load introduction to the test section. Strain survey showed a significant stress reduction at the point of failure of the first failed beam; however, despite a thorough visual inspection, before all the beams could be thus reinforced, a 0.5 inch crack was found in the same load transition area location on a second beam. It was concluded, therefore, that 45,000 psi did not permit an adequate inspection interval before crack propagation to failure.

4.1.5.1.3 Significance of Transition Bay Stress Concentration. It should be noted that a stress concentration such as was found in the transition bay, $K_t = 1.35$, is not severe when compared to the 2.5 - 3.0 attributed to fastener holes or other conventional, unavoidable design features. Holes were omitted from the I beams initially because it was correctly reasoned that if holes were present, no cracks caused by surface roughness or lack of hand-finishing would have an opportunity to appear. It developed, however, that even a moderate stress concentration, such as the one described, was much more critical than an as-machined or rough surface.

4.1.5.1.4 Long Life with Reinforcement. The MSSL was then lowered to 30,000 psi. Fracture analysis indicated 10% as rapid a crack growth rate as at 45,000 psi. Doublers were now in place over the transition area on all beams; however, upon resuming testing, the second beam soon failed in the transition bay due to re-activation of the 0.5 inch crack polished out previously. A crack was also found and polished out in the third beam transition bay at the time of doubler installation. This beam, however, survived at the 30,000 psi MSSL to go to 265 blocks with failure near midspan after

4.1.5.1.4 (Cont'd.)

generating three cracks which appeared, were polished out, and re-appeared. The beam life of 265 blocks was 3.3 times the F-111 requirement.

The remaining eight aluminum beams with doublers and without holes, loaded with F-111 and F-16 spectra, were loaded to various MSSL's as testing economics dictated. All cracks and failures were in the test section of the span. One beam, S/N 758, stubbornly refused to develop cracks. MSSL was raised to 35,000 psi at 200 blocks. The beam continued to block 394 when the first crack appeared - in the hand-finished zone. Finally, from economic necessity, the MSSL was raised to 50,000 psi at block 415, and failure occurred at block 422 - in the as-machined zone, symmetrically opposite to the first crack in location. Failure occurred at 422/80 or 5.3 times the F-111 life demonstration requirement of 16,000 hours, or 21 F-111 lives.

4.1.5.1.5 Titanium I beams. The stress level selected as the F-16 design MSSL for 6Al-4V beta annealed titanium was 68,000 psi; however, program time and budget limitations compelled raising the MSSL to as high as 94,000 psi on five of the six beams. Also, to expedite crack initiation the transition bay doublers were removed. Four of the five beams failed in the transition bay and one in the test zone. Being a rather typical design detail, the transition bay was also considered a test zone. Three of the five beams were loaded to 94,000 psi and failed below the 40 block F-16 life requirement. Two, at 87,000 and 90,000 psi went somewhat above.

One titanium I beam was left at 68,000 psi, the assumed F-16 design MSSL, while permitting more rapid test progress in the other three fixture positions. This beam demonstrated adequate life, failing at 120 blocks, three times the F-16 requirement. Crack propagation was watched in both ends of the beam in the transition bays. The first crack observed was in the as-machined end, but failure occurred in the hand-finished end.

4.1.5.1.6 Aluminum I Beams with Fastener Holes. These beams were tested to the F-16 design MSSL of 30 ksi, without transition bay doublers since holes were known to be more critical than the transition bay radius. In every respect, these beams represented realistic aircraft wing applied stress and detail design conditions. If each of these beams had been a F-16 wing, each would have passed its demonstration requirement acceptably, with one exception. Failure occurred after 40 blocks, the first crack detection occurred after 40 blocks, and crack initiation was found - after metallurgical examination - to have occurred after 40 blocks. The one exception, beam S/N 316, was found to have had crack initiation at approximately 35 blocks.

Beam failures occurred in various locations along the beam but all cracks originated at fastener holes. Of the 144 holes in the four beam flanges receiving the high tension stress - representing the F-16 wing lower surface - 39 holes had cracks, with distribution fairly uniform along the beam.

The detail results are illustrated and discussed in section 4.2. Appendix F, Figure F-1, should be referred to for a good perspective of the test history.

4.1.5.2 Component Verification Tests

The four inboard F-111 rear spar segments were tested with a MSSL of 24,000 psi. The same spectrum was used as for the I beams representing the F-111 wing. Segments were tested to 120 blocks - six service lives - instead of the four required for the aircraft, a recognition of the fact that these were component tests with a lack of the completeness in representation that a test of the actual aircraft provides. The outboard spar segments were also tested to six lives, to a MSSL of 28,000 psi which represented the design MSSL in that portion of the rear spar.

Testing of the outboard spar segments happened to be concurrent with the latter stages of I beam testing, so testing was continued beyond the requirement of 120 blocks until I beam testing was completed, at no added test support cost. The four specimens were stopped at 228-230 blocks, 11.5 F-111 lives.

4.1.5.2 (Cont'd.)

After testing, the eight segments went through pre-penetrant etch to remove machining/hand-finishing smears and make dye penetrant examination more reliable in detecting cracks. No cracks were found in any specimens.

The YF-16 titanium frame was tested to six service lives, or 60 blocks, for the YF-16 vertical tail rolling moment test spectrum with a MSSL of 38,000 psi. No cracks were found by visual inspection. The maximum stress was then raised to 67,000 psi and failure occurred in just over five blocks more, or 65 blocks.

Failure occurred in the hand-finished half of the -7 frame. The vertical tail load reversal damaged the fracture surface and prevented metallurgical determination of the time of crack initiation. The specimens were then examined by dye penetrant. Five radial cracks were found around the loading bolt hole, and two cracks in one flange, all in the as-machined portion of the -7 part. The -9 part had one crack on the outside flange in the as-machined portion. Appendix F, Figure F-23 illustrates the results.

4.2 ANALYSIS OF RESULTS

The I beam tests showed clearly that surface roughness and residual stresses - tensile or compressive - were not the dominant factors affecting fatigue life. In fact, there was no evidence of correlation between measured roughness and fatigue life. Instead, fatigue life was largely influenced by the degree of geometric design stress concentration and stress level. For example, at the design maximum spectrum stress level for the YF-16 aircraft, the dominant influence was the presence of fastener holes.

Without holes, the I beams posed a problem to the test program - that of excessive life relative to contract span time and budget. This fact, in itself, is a testimonial to the lack of importance of surface roughness control. When failure in these beams did occur, failures were more frequent in those areas with as-machined surface than in hand-finished surfaces; however, in three such cases cracks in as-machined surfaces were followed shortly by cracks in hand-finished surfaces (see 4.2.1.1.3).

Since the original program plan for generating adequate data was dependent on the development of cracks followed by polishing out of these cracks and then generating more cracks so as to achieve a respectable sample size, stress level was raised to higher and higher levels so as to generate the cracks. A new problem then arose in that the resulting inspection interval became so short as to make crack arrest almost impossible.

The effect of this predicament was to reduce statistical data sample size to a level less than originally desired, as will be seen.

F-16 parts are required to be processed through pre-penetrant etch prior to inspection. Etching the I beams would have masked the desired comparison between as-machined and hand-finished surfaces, so etching was not called for; however, it is likely that the frequency of cracks in the two types of finish would have been quite different if the beams had been etched. The probable results would have been to further emphasize the futility of hand-finishing for the purpose of controlling either roughness or residual stress. Paragraph 4.2.1.1.3 discusses the nature of residual stress.

4.2.1 Analytical Approach

The testing of I beams at various stress levels at, and above, design MSSL required that fatigue analysis be performed to normalize the test results to a common stress baseline for each spectrum and for each material. This work is presented in Appendix G. Once the test data was normalized, the various comparative analyses could be performed.

4.2.1.1 Description of Analytical Methods

Several approaches to evaluation of type of surface finish were taken. One, the simplest, is perhaps the most convincing. Roughness at failure sites was compared to equivalent fatigue life. Another was to show the frequency of crack distribution when fastener holes are present. A third analytical tool was the relative fatigue notch sensitivity factor which, for a given geometric stress concentration factor, K_t , and material, shows the notch sensitivity to other possible influence such as roughness, finish, and loading. Finally, the statistical analysis from review of all of these approaches, in Appendix H, is summarized in general terms herein.

The basic data from which all analyses were derived are summarized in Tables VIII, IX, X, XI, and XII.

4.2.1.1.1 Surface Roughness vs. Equivalent Fatigue Life. Figure 31 shows the local measured roughness at the I beam failure site and the associated fatigue life. All I beams except those with fastener holes are included. If one encountered this plot with no background in this technical field, one might be tempted to suspect that fatigue life increases as measured roughness increases; however, such an interpretation is not suggested. It is sufficient to observe that there is no trend of either measured roughness or type of finish - as-machined or hand-finished - versus fatigue life that substantiates the widely held belief that control of measured roughness is necessary to maximize fatigue life.

Appendix I contains a comprehensive discussion and tension coupon test data on the relationship between milled roughness and fatigue life. A number of data plots are provided of stress versus constant amplitude loading cycles for various roughness, loading conditions and finishes for two aluminum alloys. The lack of correlation between fatigue life and measured roughness

TABLE VIII

TEST SUMMARY - ALUMINUM I-BEAMS WITHOUT FASTENER HOLES

S/N	LOC. NO.	CRACK LOCATION (2) (9)		SURFACE ROUGHNESS μ IN., AA	S. ROUGH. @ OPP. END μ IN., AA	EQUIV. BLOCKS @ TO INITIATION @ MSSL (1)	K _t (3)	q (4)	COMMENT	
		FINISH UP/ LWR FLANGE	NEAR/ FAR SIDE							OUTSIDE/ INSIDE FLANGE
ALUMINUM 2124-T851 F-111 SPECTRUM, 24 KSI MAX. SPECTRUM STRESS LEVEL										
755	<u>1</u> 1	A-M H-F	LF LF	NS --	IF IF	107 26-44	26-44 107-110	∞	1.35	.1117
764	<u>1</u>	A-M	LF	--	IF	45-58	25-28	758	1.35	.2505
759	1 4 <u>3</u>	A-M A-M A-M	LF LF LF	-- -- NS	IF IF IF	37-51 35-54 50	29-36 31-35 33-35	∞	1.10	.1224
762	<u>3-4</u>	H-F	LF	FS	OF	6	45-78	15,385	1.10	.1556
758	4 <u>4-5</u>	H-F A-M	UF UF	-- FS	IF IF	11-15 38-79	58-79 15-26	22,222	1.10	.1357
ALUMINUM 2124-T851 YF-16 SPECTRUM, 30 KSI MAX SPECTRUM STRESS LEVEL										
757	(2-3)	(H-F)	UF	FS	OF	(5)	--	235	1.10	.8293
760	(2-3)	(A-M)	UF	NS	OF	(5)	16-25	455	1.10	.6024
765	2-5 <u>6</u>	A-M A-M	LF LF	-- NS	IF IF	41-69 102	13-21 16	900	1.10	.4821

- NOTES: (1) Actual applied stress levels and blocks to failure were "normalized" to the MSSL and resulting estimated life by procedures described in Appendix G.
 (2) Location and accompanying roughness is correlated in Appendix G.
 (3) Geometric stress concentration, reference Appendix G.
 (4) Fatigue notch sensitivity factor, reference Appendix G.
 (5) Failed due to local damage.
 (6) Underlined location indicates failure location
 (7) Number of primary failures in as-machined surfaces 5
 in hand-finished surfaces 1
 as-machined surfaces 8
 hand-finished surfaces 3
 (8) Distribution of cracks:
 As-machined (A-M); Hand-finished (H-F);
 Upper flange = UF; Near side = NS; Outside flange = OF
 Lower flange = LF; Far side = FS; Inside flange = IF

TABLE IX
TEST SUMMARY - TITANIUM I-BEAMS

S/N	CRACK LOCATION (2)			SURFACE ROUGHNESS μ IN., AA	S. ROUGH. OPP. END μ IN., AA	EQUIV. BLOCKS TO INITIATION @ MSSL (1)	K _L (3)	q (4)		
	LOC. NO.	FINISH	UPR/LWR FLANGE						NEAR/ FAR SIDE	OUTSIDE/ INSIDE FLANGE
TITANIUM 6Al-4V T1 BETA ANNEALED YF-16 SPECTRUM, 68 KSI MAX. SPECTRUM STRESS LEVEL										
767	1 1 1	A-M H-F A-M	UF UF LF	FS NS NS	IF IF IF	73 36 32	43 37 52	1,667	1.35	.2638
768	1 1 3-4	A-M H-F H-F	LF LF LF	FS NS NS	IF IF OF	30 55 34	30 57 100	2,000	1.35	.2614
769	3-4	A-M	UF	FS	OF	55	22	2,000	1.10	.2706
772	1 1	H-F A-M	UF UF	NS FS	IF OF	48 70	33 24	1,333	1.35	.2698
771	1	A-M	UF	NS	IF	44	23	2,000	1.35	.2614
770	1 1	H-F A-M	LF LF	FS NS	OF OF	34 60	55 34	625	1.35	.2912

- NOTES: (1) Actual applied stress levels and blocks to failure were "normalized" to the MSSL and resulting estimated life by procedures described in Appendix G.
(2) Location and accompanying roughness is correlated in Appendix C.
(3) Geometric stress concentration, reference Appendix G.
(4) Fatigue notch sensitivity factor, reference Appendix G and par. 4.2.1.1.4.
(5) Underlined location indicates failure location.
(6) Number of primary failures in as-machined surfaces 3
in hand-finished surfaces 3
as-machined surfaces 7
hand-finished surfaces 5
(7) Distribution of cracks:

TABLE X
TEST SUMMARY - ALUMINUM I-BEAMS WITH FASTENER HOLES

S/N (1), (2)	NO. OF CRACKS AT FAILURE	NO. OF (3) CRACKS IN		BLOCKS AT CRACK INITIATION	BLOCKS AT FAILURE	K_t (4)	q (5)
		H-F	A-M				
761	4	<u>4</u>	0	45	56	2.80	.2556
763	9	5	<u>4</u>	57	65	2.80	.1333
766	15	<u>4</u>	11	45	62	2.80	.2556
316	11	<u>10</u>	1	35	48	2.80	.4352
		(23)	(16)				

- NOTES: (1) 2124-T851 ALUMINUM WITH 1/4" DRILLED HOLES @ REGULAR SPACING, IN EACH SIDE OF EACH FLANGE.
- (2) YF-16 SPECTRUM WITH 30 KSI MAX. SPECTRUM STRESS LEVEL (MSSL). MSSL AND ACTUAL TEST STRESS LEVEL WERE IDENTICAL, SO NO "NORMALIZATION" BY FATIGUE ANALYSIS WAS NECESSARY.
- (3) UNDERLINED NUMBER INDICATES SIDE WHERE FAILURE OCCURRED.
- (4) GEOMETRIC STRESS CONCENTRATION, REFERENCE APPENDIX G, BASED ON NET SECTION STRESS.
- (5) FATIGUE NOTCH SENSITIVITY FACTOR, REFERENCE APPENDIX G AND PAR. 4.2.1.1.4.

TABLE XI

SUMMARY OF TEST RESULTS AT SITE OF FAILURE - I-BEAM SPECIMENS

S/N	MATL	R _f (1)	MAX. SPECTRUM DESIGN STRESS (KSI)	SURFACE CONDITION AT FAILURE SITE		EQUIV. BLOCKS TO INITIATION @ MSSL	TOTAL CRACKS		FATIGUE NOTCH (2) SENSITIVITY (q)	REMARKS
				TYPE	ROUGHNESS (μ IN., AA)		A-M	H-F		
759	AL	1.10	24	A-M	50	22,222	3	0	.1224	
758	AL	1.10	24	A-M	38-79 (58.3)	15,385	1	1	.1357	
762	AL	1.10	24	H-F	6	800	0	1	.1556	
765	AL	1.10	30	A-M	102	455	2	0	.4821	
760	AL	1.10	30	A-M	19-28 (23.5)	235	1	0	.6024	
757	AL	1.10	30	H-F	16-17 (16.5)		0	1	.8293	
755	AL	1.35	24	A-M	107	∞	1	1	.1117	DAMAGED FLG
764	AL	1.35	24	A-M	45-58 (51.5)	758	1	0	.2505	DAMAGED FLG
763	AL	2.80	30	A-M	70	57	4	5	.1333	W/FSTNR HOLES
761	AL	2.80	30	H-F	16	45	0	6	.2556	W/FSTNR HOLES
766	AL	2.80	30	H-F	23	45	11	4	.2556	W/FSTNR HOLES
316	AL	2.80	30	H-F	17	35	1	10	.4352	W/FSTNR HOLES
769	Ti	1.10	68	A-M	55	2,000	1	0	.2706	
768	Ti	1.35	68	H-F	55	2,000	1	2	.2614	
771	Ti	1.35	68	A-M	44	2,000	1	0	.2614	
767	Ti	1.35	68	A-M	73	1,667	2	1	.2638	
772	Ti	1.35	68	H-F	48	1,333	1	1	.2698	
770	Ti	1.35	68	H-F	34	625	1	1	.2912	

NOTES: (1) Geometric stress concentration at failure site (Reference Appendix G).
 (2) Reference Appendix G and par. 4.2.1.1.4.

TABLE XII
EFFECT OF SURFACE FINISH ON FATIGUE NOTCH SENSITIVITY
AND SURFACE ROUGHNESS - I-BEAM SPECIMENS

MATERIAL	K _t (1)	MAX SPECTRUM DESIGN STRESS -KSI- (SPECTRUM)	SURFACE FINISH AT FAILURE SITE	QUANTITY OF SPECIMEN FAILURES	FATIGUE NOTCH (2)		SURFACE ROUGHNESS AT FAILURE SITE	
					MEAN (\bar{q})	STD DEV	MEAN ($\bar{\mu}$ IN., AA)	STD DEV
ALUMINUM	1.10	24 (F-111)	A-M	2	.1291	.0094	↑	↑
			H-F	1	.1556	--	↓	↓
	1.35	30 (YF-16)	A-M	1	.4821	--	↑	↑
			H-F	0	--	--	↓	↓
	2.80	30 (YF-16)	A-M	2	.1811	.0981	↑	↑
			H-F	0	--	--	↓	↓
			1	.1333	--	↑	↑	
			3	.3155	.1037	↓	↓	
TITANIUM	1.10	68 (YF-16)	A-M	1	.2706	--	↑	↑
			H-F	0	--	--	↓	↓
	1.35	68 (YF-16)	A-M	2	.2626	.0017	↑	↑
			H-F	3	.2741	.0154	↓	↓
						66.07 A-M	29.78	
						15.70 H-F	6.12	
						57.33 A-M	14.64	
						45.67 H-F	10.69	

NOTES: (1) Geometric stress concentration at failure site (Reference Appendix G).
(2) Reference Appendix G.

4.2.1.1.1 (Cont'd.)

is evident. These data were generated in a General Dynamics Fort Worth Division IRAD program.

In addition, some of the data developed by Metcut Research Associates under an AFML contract (reference 3) is shown in Appendix I for aluminum and titanium, for further substantiation of the lack of such correlation.

4.2.1.1.2 Crack Distribution in Beams with Fastener Holes.

Figure 32 shows the overwhelming domination by fastener holes over any other intentional geometric design feature in these test parts and, of course, surface roughness. These holes have an estimated stress concentration factor, $K_t = 2.8$, based on net section stress, which over-rides the transition bay K_t of 1.35 and the test section typical stiffener-flange intersection which has a K_t below 1.1.

Cracks initiated in each beam such that the sum total of cracks for all the four beams was fairly uniformly distributed, as the plot illustrates. The fact that more cracks and three of four catastrophic failures occurred in the hand-finished half of the beams briefly attracted the attention of the statisticians, but was dismissed as random in nature.

4.2.1.1.3 Crack Distribution vs. Type of Finish.

Table XIII shows the distribution of crack and failures in hand-finished and as-machined surfaces of the aluminum and titanium I beams. The statistical analysis showed a 89% confidence level that cracks are more likely to occur in as-machined surfaces than in hand-finished surfaces but also concluded that finish and roughness effects could not be separated; therefore, the roughness could not be said to be a contributing factor which, however, does not exclude its effect.

Early in the test program it became clear that cracks and failures would be more frequent in as-machined areas than in those that were hand-finished. Since as-machined areas were usually rougher than hand-finished areas, the program objective seemed to be jeopardized. Metcut Research Associates suggested a residual stress analysis, since hand-finishing was known to affect residual stress. Specimens were cut from the stiffeners of a failed beam, from the as-machined and from the hand-finished sides. Stiffeners were selected because other more highly stressed beam elements such as flanges might

TABLE XIII

CORRELATION OF FINISH AND CRACK FREQUENCY
IN I-BEAM SPECIMENS W/O FASTENER HOLES

TYPE SPECIMENS	TOTAL CRACK POPULATION		CRACKS CAUSING FAILURE	
	H-F	A-M	H-F	A-M
ALUMINUM I-BEAMS*	3	8	1	5
TITANIUM I-BEAMS	5	7	3	3
TOTAL	8	15	4	8

*TWO SPECIMENS (S/N 757 AND 760) FAILED DUE TO LOCAL
DAMAGE AND ARE NOT INCLUDED IN THIS DATA.

4.2.1.1.3 (Cont'd.)

have relaxed the residual stresses due to the high cyclic loading. Metcut then performed an X-ray diffraction analysis. The results are shown in Figure 33. The magnitude of the stresses in both tension and compression shows a dramatic contrast. It is quite believable that crack initiation would be delayed due to such a high surface compression stress. The depth of penetration, however, is only 0.001 inches. A crack in an as-machined surface would, therefore, possibly be followed closely by one in a hand-finished area. Such was the case in two aluminum beams (S/N 755 and 758) and one titanium beam (S/N 770). Four aluminum beams and three titanium beams had cracks only in a single type of finish, more often the as-machined side. Appendix F, Figure F-1 should be referred to for this discussion.

Such data is hardly enough for a conclusion as to the relative merits of the two finishes, but it offers a convincing explanation of the failure trends. More important, it suggests that the difference in fatigue life between the two types of finish does not involve their measured roughnesses.

One might be tempted to utilize hand-finishing to enhance fatigue life in certain specialized structural elements; however, hand-finishing is by its nature non-repeatable in useful terms. Furthermore, it seems futile to induce 0.001 inches of residual stress and then etch away 0.0005 inch thereby removing the majority of the benefit, when performing pre-penetrant etching prior to inspection.

4.2.1.1.4 Variation in Notch Sensitivity Factor. In an attempt to isolate the effects of roughness and finish process from the geometric stress concentration factor and conventional material characteristics, the notch sensitivity factor was utilized. Reference 1, pages 368-375, may be consulted for an academic discussion of notch sensitivity, but a brief explanation is provided herein for the reader's convenience.

The ASTM Standard of reference 2 defines fatigue notch sensitivity, q , as "a measure of the degree of agreement between K_f and K_t ."

$$q = (K_f - 1)/(K_t - 1) \quad (1)$$

K_f is defined in reference 2 as "the ratio of the fatigue strength of a specimen with no stress concentration to the

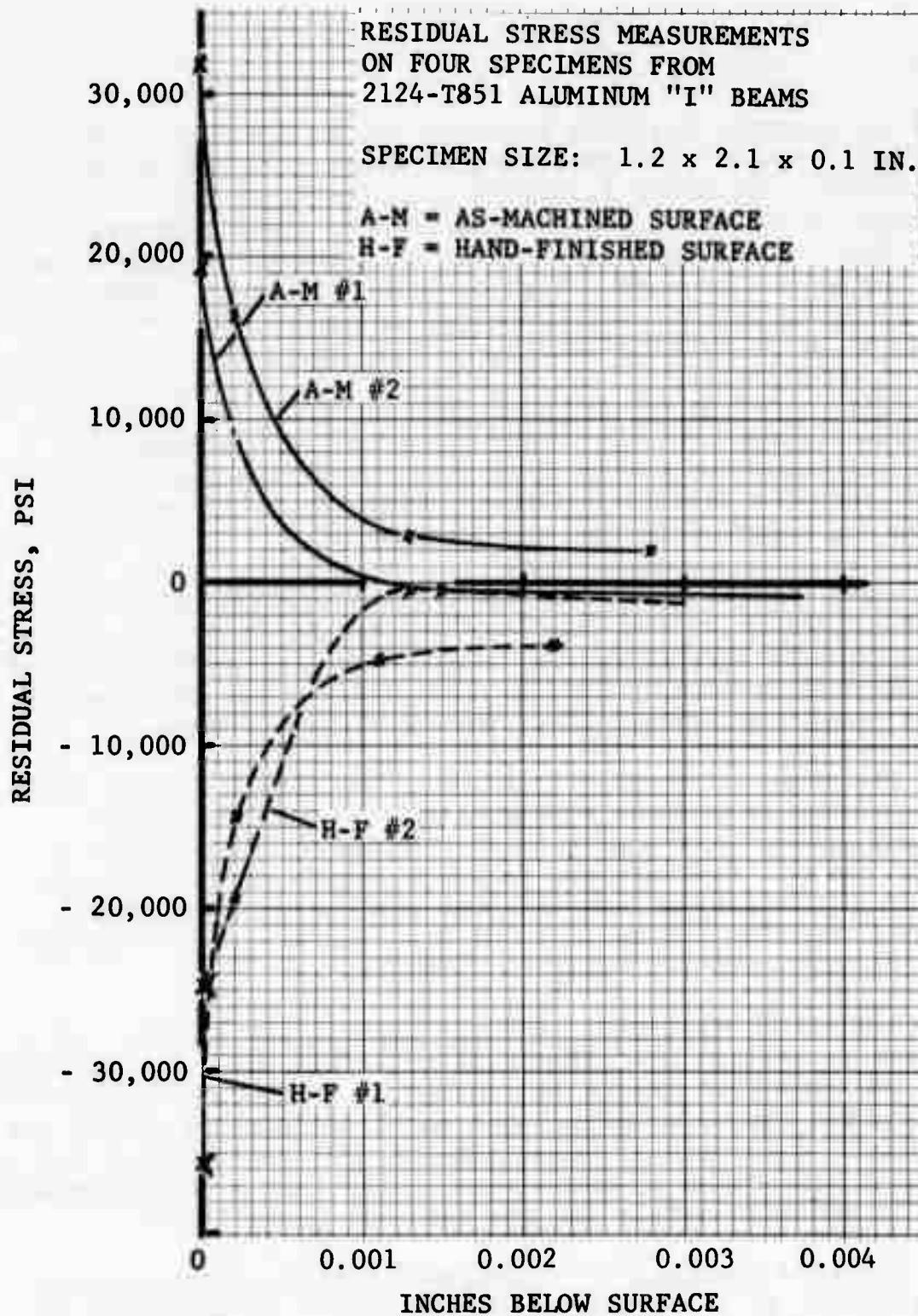

FIGURE 33 RESIDUAL STRESS IN MILLED ALUMINUM

4.2.1.1.4 (Cont'd.)

fatigue strength at the same number of cycles with stress concentration for the same conditions."

$$\text{or } K_f = \sigma_n / \sigma'_n \quad (2)$$

K_t is defined in reference 2 as "the ratio of the greatest stress in the region of a notch or other stress concentrator as determined by the theory of elasticity (or by experimental procedures that give equivalent values) to the corresponding nominal stress".

K_f is commonly determined by experiment, as was done in the tests described in this report (Appendix G) and is usually less than K_t . The variables that are known to influence K_f are the material, the character of the geometric discontinuity, the magnitude of stress and the number of cycles endured.

In this test program, the various data were isolated in groups, i.e. in Table XI, each group of beams represents its own conventional K_t , material and loading. The remaining variables are measured roughness, the two competing types of finish and the fatigue life achieved. These variables - if significant - will contribute in varying degrees to K_f (see Appendix G) which, in turn, permits determination of q , the notch sensitivity factor, plotted in Figure 34.

Figure 34 shows q plotted versus fatigue life for each K_t and material type. Each type of finish and loading is identified for each data point. Figures 35 and 36 show q plotted versus measured roughness at the failure site for aluminum and titanium.

In Figure 34, for aluminum specimens with $K_t = 1.10$, the two beams with damaged flanges have the highest q . The damage on one was a bruise at the edge of the flange that escaped detection. The other was damaged by hand grinding during installation of the doublers over the transition bay, shown in Appendix F, Figure F-9. These flaws were dominant over finish.

Another trend that dominated over finish was loading. The combat fighter YF-16 spectrum had not only a higher design MSSL but also is known to be a more severe spectrum than the F-111 fighter/bomber spectrum. The YF-16 data points appear to generate a higher q than the F-111 data points.

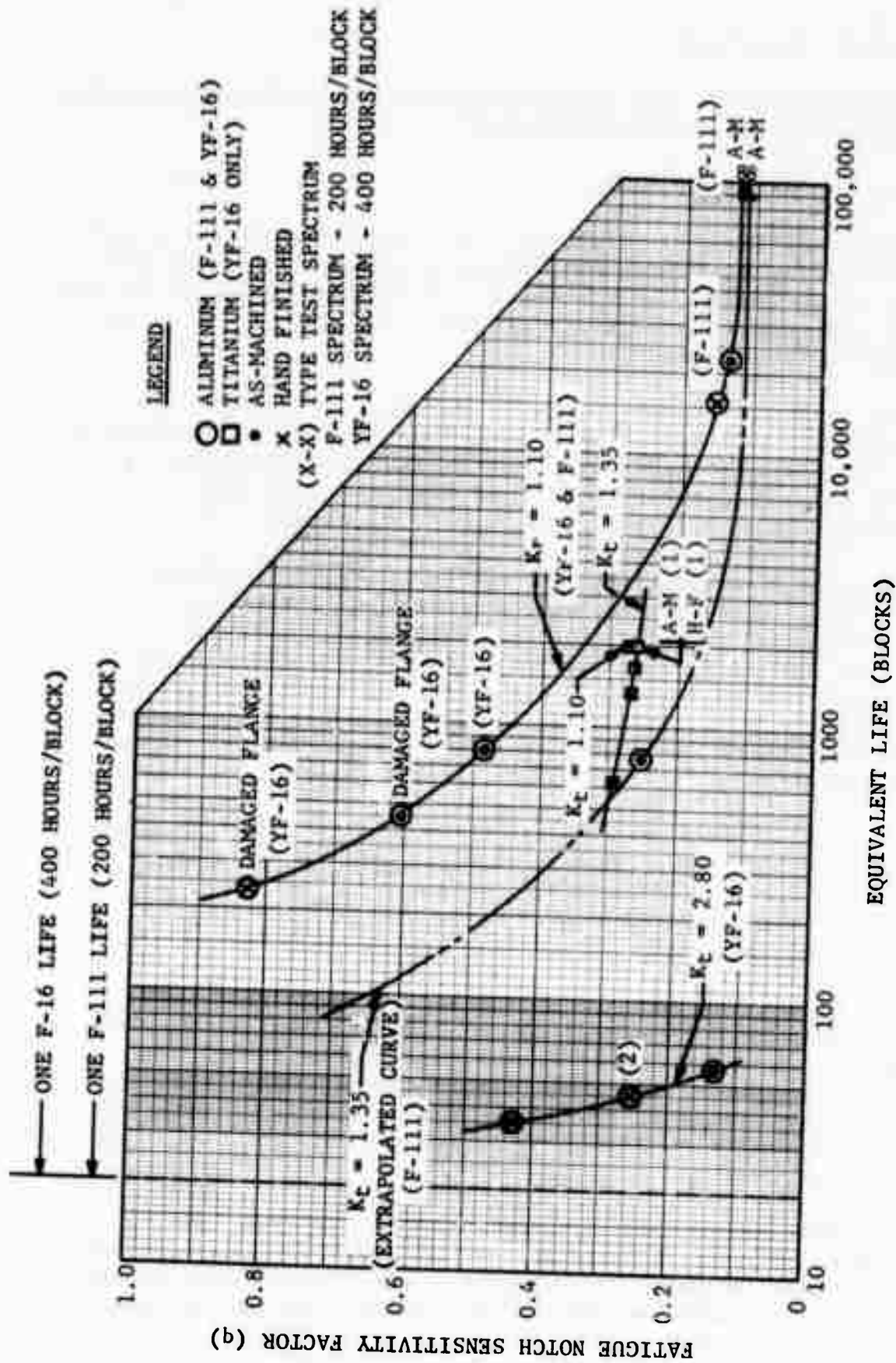

FIGURE 34 CORRELATION BETWEEN NOTCH SENSITIVITY FACTOR AND FATIGUE LIFE - I-BEAM SPECIMENS

4.2.1.1.4 (Cont'd.)

The four beams with holes - $K_t = 2.80$ - seemed to have a higher q due to being hand-finished, but the sample size is too small for such a conclusion.

For the titanium specimens, the lives were less and q was higher for those beams that failed in hand-finished areas. Again, sample size is inadequate for such a conclusion.

In summary, however, there is no evidence to support a need for hand-finishing.

Figure 35 shows no correlation between q and measured roughness for aluminum. Figure 36 shows a rather strong lack of correlation for titanium despite a fairly wide variation in measured roughness.

4.2.1.1.5 Summary of Statistical Analyses. Appendix H presents a comprehensive analysis of the relationships between fatigue life, crack probability and notch sensitivity as these may be related to finish and roughness.

It should be noted that a statistical analysis can conclude that a difference between values representing either small or large sample sizes can be statistically not significant; conversely, if a relationship is said to exist, it means that the relationship has met certain statistical test requirements.

A summary of the Appendix H discussion follows:

1. Both cracks and failures are more likely in as-machined surfaces on aluminum beams.
2. Within as-machined surfaces, the difference in roughness at failure sites compared to elsewhere is not significant.
3. Failure cannot be related to measured roughness only, because these surfaces may be either as-machined or hand-finished and the two effects - roughness and finish - cannot be separated.
4. No relationship can be established between surface finish and equivalent fatigue life.

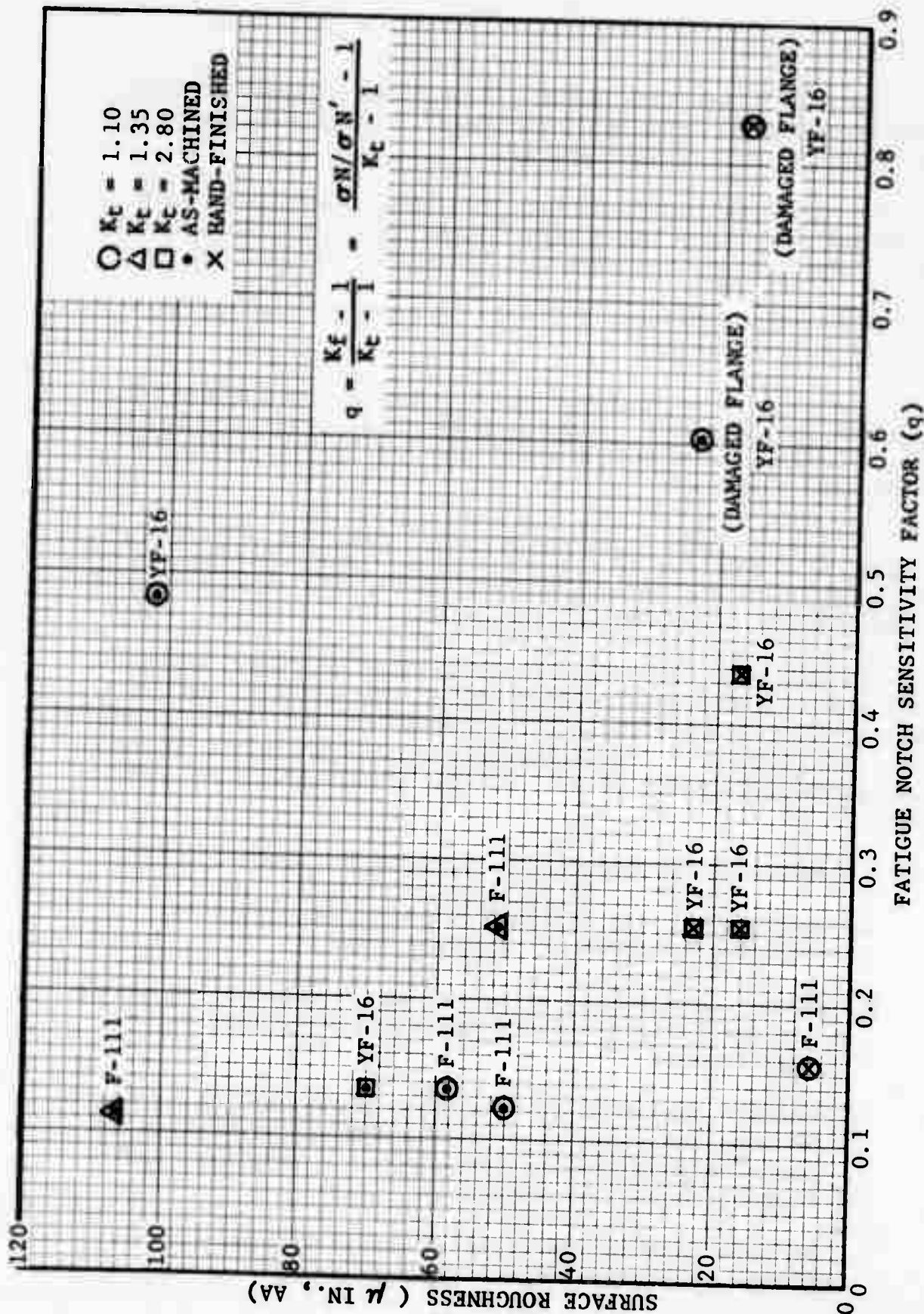

FIGURE 35 CORRELATION BETWEEN NOTCH SENSITIVITY FACTOR AND SURFACE ROUGHNESS - ALUMINUM I-BEAMS

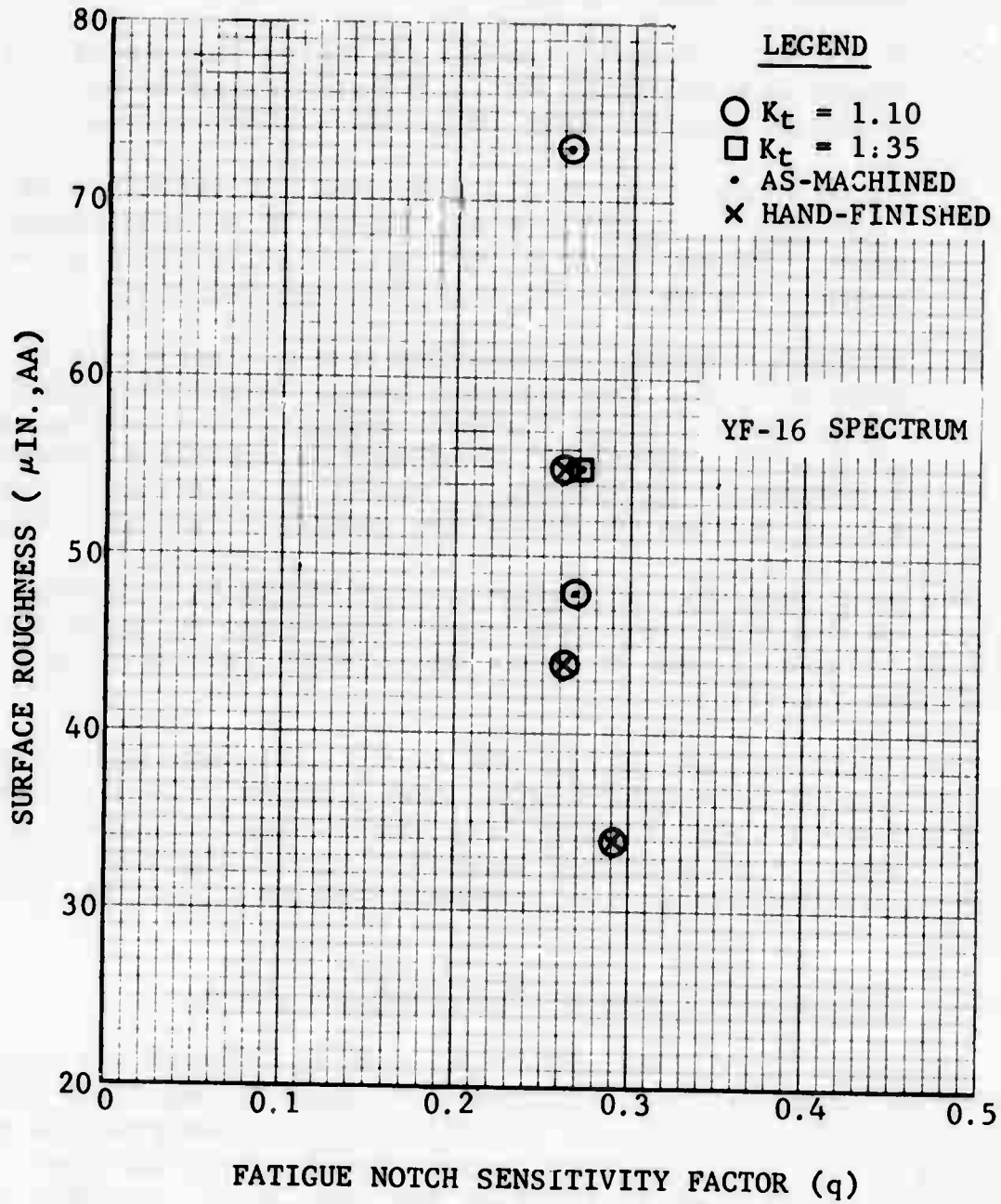

FIGURE 36 CORRELATION BETWEEN NOTCH SENSITIVITY FACTOR AND SURFACE ROUGHNESS - TITANIUM I-BEAMS

4.2.1.1.5 (Cont'd.)

5. On beams with fastener holes, crack distribution is random, without regard to surface roughness or finish.
6. On titanium beams, evidence is weaker than it is for aluminum that cracks will initiate sooner in as-machined surfaces than in hand-finished surfaces.
7. Notch sensitivity on aluminum does not appear to be relatable to either surface finish or measured roughness. Therefore, it cannot be determined that either surface finish is more critical than the other.
8. Notch sensitivity on titanium does not appear to be relatable to either surface finish or measured roughness. (There is no rational basis for the indication that notch sensitivity decreases as surface roughness increases). Therefore, it cannot be determined that either surface finish is more critical than the other.

The only positive conclusion that statistical analysis provided is the first item, that both cracks and failures in aluminum are more likely in an as-machined surface than in a hand-finished surface.

The remaining conclusions are essentially negative. This could be due to inadequate sample size; however, if no correlation existed between fatigue life and measured roughness or finish - which other evidence described previously does strongly indicate - the statistical analysis results would also be negative.

4.2.1.2 Analysis of Component Verification Tests

Paragraph 4.1.5.2 describes the test history of the eight F-111 spar segments, four of which were hand-finished and four which were left as-machined. These parts were designed and manufactured to all F-111 aircraft requirements except for the finish and except that they had no fastener holes. Loaded to the design MSSL, four tests were stopped at six lives, and four at 11.5 lives. No cracks were found in any parts after thorough inspection.

4.2.1.2 (Cont'd.)

The results substantiate the analytical results of the I beam tests. An aluminum component without fastener holes, designed with conventional detail design features and a MSSL arrived at through current fatigue and fracture considerations, will survive many lives beyond requirements before initiating cracks - possibly with infinite life. The lack of hand-finishing did not influence the test results.

The titanium frame test regrettably was inconclusive as to the time of crack initiation. The component passed the life requirement, and no cracks were found during a subsequent visual inspection; however, when testing was resumed at a higher stress - one more typical for a titanium design MSSL - failure occurred after only five blocks. Although five blocks is a fourth of a life of the YF-16 spectrum, it is felt that cracks must have existed and escaped the visual inspection. The 100% reversible loading damaged the fractured surfaces and prevented estimation of the time of crack initiation.

The primary failure was in a hand-finished area, but there were several cracks in both as-machined and hand-finished areas (Appendix F, Figure F-23). Local loading appeared to be the dominant factor, as at the large load bolt holes. Finish appeared to play no role in the distribution of cracks.

4.2.2 Conclusions Derived from Analyses

The program test and analytical results described in Section 4 have resulted in the following conclusions at General Dynamics Fort Worth Division and have led to implementation in design and inspection requirements on the F-16 program.

1. Control of measured roughness is not required to provide adequate fatigue life on milled and routed aluminum airframe parts.
2. Although the program test results on titanium also show that measured roughness is not relatable to fatigue life, the tests by Metcut Research Associates, Inc. described in reference 3 and Appendix I, Figure I-5 suggest that fatigue life is affected by the orientation of the applied stress to the milled surface wave - or lay - direction although not to

4.2.2 (Cont'd.)

- the accompanying measured roughness. In addition, it is felt that not enough is known about the sensitivity of titanium alloys to abusive milling. Consequently, the traditional controls on measured roughness and hand-finishing have not been relaxed for this material.
3. In a milled aluminum aircraft component with fastener holes and conventional, moderate, geometric discontinuities, along with a design MSSL established by current Air Force procurement requirements, cracks will initiate earlier in fastener holes regardless of the distribution of surface roughness or type of finish.
 4. If there are no fastener holes in a part such as is described in item 3, cracks will initiate only long after aircraft life requirements have been met. In such a case, cracks will initiate first in as-machined surfaces. It is likely that hand-finished surfaces will develop cracks shortly afterwards. It is also possible that under the above conditions, cracks will not initiate regardless of the duration of loading, depending on the type of load spectrum.
 5. It is not known how to induce a specific magnitude or direction of a residual stress, nor is it known if all techniques for hand-finishing will induce only a compressive residual stress.
 6. The above conclusions are not applicable to the roughness within fastener holes.

4.3 INSPECTION STANDARDS ON ROUGHNESS

The conclusions described in paragraph 4.2.2 led to a revision to the General Dynamics Fort Worth Division standard used by engineering and inspection on milled aluminum airframe parts. The document is an "M" standard, one of many standards developed by engineering for use in manufacturing. The portion of the standard dealing with aluminum is shown in Appendix I, Figure I-6. It is divided into sections dealing with surface roughness and also with mismatches, each with a critical and a non-critical category. It also includes requirements on dimensional tolerances.

4.3 (Cont'd.)

Each airframe drawing calls out the standard in the drawing notes. Symbols are then used on the face of the drawing to identify surfaces considered critical. All other surfaces are then considered non-critical.

NC programming and the machine shop - including hand-finishers - take special pains to program, machine and hand-finish as necessary to meet critical area requirements. Inspection then uses the document requirements to pass on part quality.

As now revised for F-16 manufacturing, the document requires hand-finishing only on surfaces that contact adjacent surfaces, and then only if the roughness exceeds a measured value of $125\mu\text{AA}$ inches (micro-inches arithmetic average). Table IV of paragraph 3.1.2.3 lists measured roughness on five different F-111 production parts. It can be seen that exceeding a 125 roughness is rare. Consequently, very little hand-finishing is done on F-16 parts. Even contact surfaces are usually judged visually by experienced inspectors eliminating profilometer readings except in marginal cases.

Mismatches are of interest to those concerned with surface roughness. A mismatch is an inadvertent step in a surface due to an inaccurate intersection of two cutter paths. The thickness of a flange will be different on each side of the mismatch. The inspection standard required that the thickness on each side be within the drawing tolerance along the flange. The standard also requires that the shape of the step have a minimum radius of 0.060 inches to minimize local stress concentration. The largest mismatch permitted would be the sum of the tolerances, i.e. a thickness with a +0.015, -0.010 inch tolerance could have a mismatch up to 0.025.

The standard as presented in Appendix I has other features also designed to reduce machining cost, but they are not relevant to this discussion.

5. NC PROGRAMMING AND MACHINING GUIDELINES

The original approach to increasing metal removal rates was to run stiffener tests of the type described in section 5.1 and produce charts that would permit a programmer to select feed rates, RPM, radial and axial cuts for the required cutter diameter that would result in an element that would be within the required dimensional tolerance. Such charts were developed and are shown in Appendix J.

The next phase applied this data to the NC programming of a test part of typical production complexity, described in paragraph 5.2. Results were far from satisfactory, however. Several attempts were made using heavy metal removal rates in accord with the charts but results were unsatisfactory both in terms of dimensional accuracy and surface quality. It was not entirely understood why this was so, but apparently the cutter forces on a complex production part were excessive for the NC machine and the production type tooling.

With great reluctance, programming was revised to lighten the finish cut and increase the RPM. Quality immediately improved; however, the original technique of using the rough cutter for all finish machining except for corners was still used. When the smaller cutter was introduced for corner machining, mismatches resulted that detracted from appearance and threatened acceptance by programmers, machinists and inspectors. Mismatches up to dimensional limits are not rejectable, but pride in quality is not to be ignored. It was decided to finish-machine all sides and corners with the small cutters and yet try to retain the cost reduction the earlier approach offered.

The basic problem was one encountered long ago by machinists. Dimensional accuracy required very light cutter forces under production conditions, an environment not reproduced adequately by the stiffener tests which did not involve corners or sufficiently wide stiffener spacing or thin webs.

5. (Cont'd.)

Nevertheless, the stiffener tests clearly showed that rough machining was needlessly conservative, and it was felt that finish machining metal removal rates could be maximized by optimizing RPM and feed rates. Also, techniques for machining of corners were selected that were less time consuming and yet produced an acceptable corner. In addition, care was selected in programming to reduce free travel time to a minimum.

The last NC development test part, S/N 10, compared adequately in quality with the conventionally programmed part, S/N 2 and achieved a cutting time reduction of over 50%, reported on in section 5.2 and Appendix K of Volume 2.

Finally, two F-16 production designs were re-programmed to the still developing guidelines. Further refinements were made in programming technique. The average reduction in cutting time for the seven pieces machined for the first part selected was 69%, and the average reduction in total time on the machine was 46%. The second design - a simpler part - was not re-programmed in full compliance with the guidelines and reduced cutting time only 48%. This work is described in section 5.3 and Appendix L of Volume 2.

The final result, reflected by the guidelines in Appendix L, achieved the hoped for cost reduction and yet does not constitute a revolutionary departure from more conventional methods. The NC programming developed for the two F-16 designs has been retained as the production programming. All of the thirteen pieces machined by these guidelines - except for two destroyed by programming/operator error - have been accepted and placed in F-16 production stock.

5.1 STIFFENER TESTS

The stiffener machining tests were designed to develop milling techniques that would increase metal removal rates and yet retain adequate dimensional and surface quality. The approach is illustrated by Figure 37. A block of aluminum - or titanium - was machined to produce 3-4 stiffeners, each stiffener machined with the same radial cut and RPM but at increasing feed rates. Each stiffener was then examined for dimensional quality and surface roughness near the center of the span to exclude free end effects.

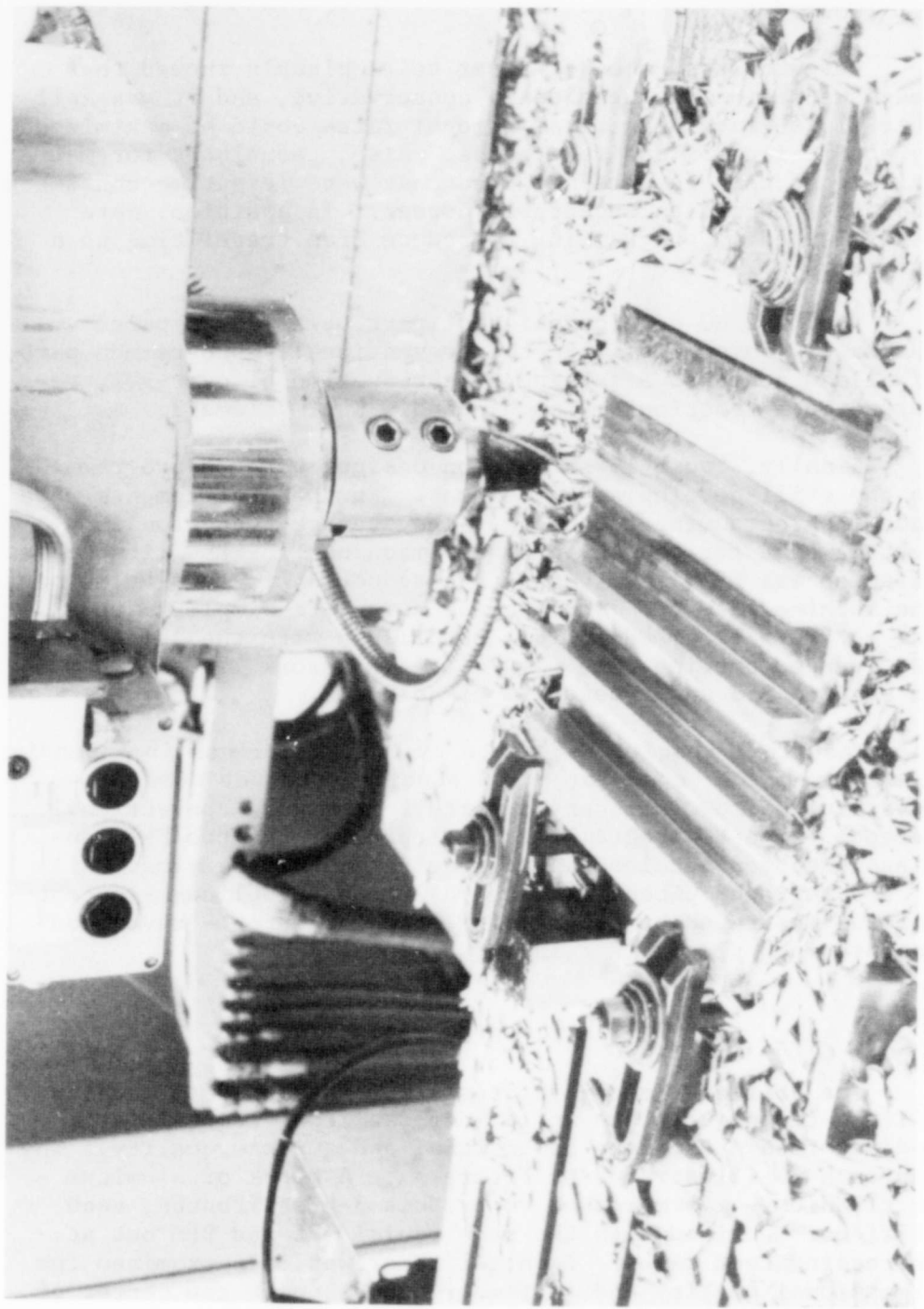

FIGURE 37 STIFFENER MACHINING TEST ON BOHLE VERTICAL MILL

5.1 (Cont'd.)

Tables XIV and XV summarize the variables in terms of cutter diameter, radial and axial cut on test serial numbers. The test results are presented in Appendix J in various Tables and data plots.

The early tests were run on a 50 hp Bohle vertical mill which has a RPM limit of under 1500. Later tests were run at higher RPM on a variety of NC 3 axis mills. Test results varied widely even for tests repeated under identical conditions for reasons not clear, as can be seen by review of Appendix J, Figures J-6 through J-10. These charts present metal removal rate limits in terms of area of cut vs. feed rate that are intended to produce dimensionally acceptable flanges and stiffeners.

The limits as presented do exploit the +0.015 inch dimensional tolerance used on F-16 drawings which leaves an insufficient margin for other uncertainties and variables. The need for this margin was not apparent until the data was used in programming and machining the NC development test specimens discussed in the next section.

5.1.1 Investigation for Overheating Effects and Smear Thickness

Although the extreme feed rates used in the stiffener tests were not anticipated in actual NC programming and machining of production parts, it was of interest to investigate whether such cutter velocities would damage material through overheating. Aluminum 2124-T851, milled with a heavy one inch radial at an extreme of 70 inches per minute, showed no difference in conductivity or microstructure from one milled at ten inches per minute or from the base metal. A similar test was run on 6Al-4V beta annealed Titanium. A stiffener milled at the unrealistic rate of 15½ inches per minute, over twice the customary titanium feed rate, and with an extreme radial cut of one inch, showed no change in microstructure from one milled at 3½ inches per minute with a light 0.05 inch radial cut. Appendix J, Figures J-12 - J-15 illustrate the results.

TABLE XIV STIFFENER MACHINING TESTS - MATRIX OF TEST NUMBERS (ALUMINUM)

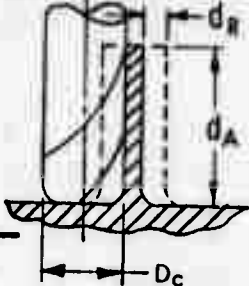
D _c	d _A	d _R							
		.05	.125	.20	.25	.375	.50	.75	1.00
.50	1.0	31	32		33				
	1.5	34	35		36				
.75	1.0	14	37		25	38			
	1.5	15	39		40	41			
1.00	1.0	42			26	43	44		
	1.5	45			46,62	47	48		
1.50	1.0	49			50		51	52	
	1.5	53			54,60,61*		55,63	56	
2.00	1.0	5,6		7			8	57	9
	1.5	4,10		3,11			1,12, 59,64	58	2,13

* "Conventional" cutter rotation, all others are "climb cuts".

TABLE XV STIFFENER MACHINING TESTS - MATRIX OF TEST NUMBERS (TITANIUM)

D _c	d _A	d _R			
		.05	.25	.50	1.00
.75	1.0	22			
	1.5	23			
2.00	1.0	16,19		17	18
	1.5		21	20	

5.1.1 (Cont'd.)

Smear thickness due to the wiping/shearing action of the end-mill was measured for an extreme range of feed rates and two extremes of radial cuts, 0.05 and 1.0 inches. Smear thickness varied roughly with metal removal rate, i.e., cutter force, up to a value of 0.00057 inches for aluminum and 0.00065 for titanium for the extremes tested. At typical finish machining metal removal rates, the smear thicknesses were roughly half of these values. The results are shown in Table XVI. This data helped establish the pre-penetrant etch requirements on the F-16 so as to meet the requirements of MIL-I-6866B, the specification governing the penetrant inspection process for "soft" metals such as aluminum and titanium.

5.2 NC PROGRAMMING DEVELOPMENT TESTS

The part configuration selected for developing NC programming techniques that would reduce cutting time had to reflect typical design details and machining problems. Figure 38 illustrates the open and closed angles and sharp corners, large and small pockets, thick and thin webs and straight and curved flanges that are commonly encountered in airframe bulkheads and frames. The design required a wide range of cutter sizes, from $\frac{1}{2}$ inch to 2 inch diameter. Each element was identified so that each web, each side of each stiffener and flange and each corner could be identified, so that data could be recorded for analysis.

Programming development was done by an experienced programmer. F-16 material was used. Machining was on production NC equipment with production operators. Machining was witnessed by the RTC Manufacturing Engineering team member who timed all operations and insured operator compliance with test requirements. Inspection was by the RTC Quality Assurance team member aided by production inspection.

5.2.1 Development Test Description

Figure 39 provides a statistical evaluation of dimensional quality useful for following this discussion. The figure summarizes the mean dimensional deviation separately for both positive and negative deviations from the nominal dimension for all elements on each test part. In addition, it was considered important to estimate the probable scatter around these mean deviations so as to predict likely production quality

TABLE XVI
MACHINING PARAMETERS FOR SURFACE EFFECT ANALYSIS

<u>Specimen Number</u>	<u>Material</u>	<u>Radial Depth of Cut</u>	<u>Feed Rate in./min.</u>	<u>Avg. Max. Depth of Smeared Metal, in.</u>
2A	2124 Al T851	1"	10	0.00009
B			30	.00026
C			50	.00042
D			70	.00057
4A		.05"	10	.00013
B			30	.00029
C			50	.00051
D			70	.00049
16A	Ti-6Al-4V Beta Annealed	.05"	3½	.00037
B			7½	.00037
C		15½	.00038	
18A		1"	3½	.00035
B			7½	.00043
C			15½	.00065

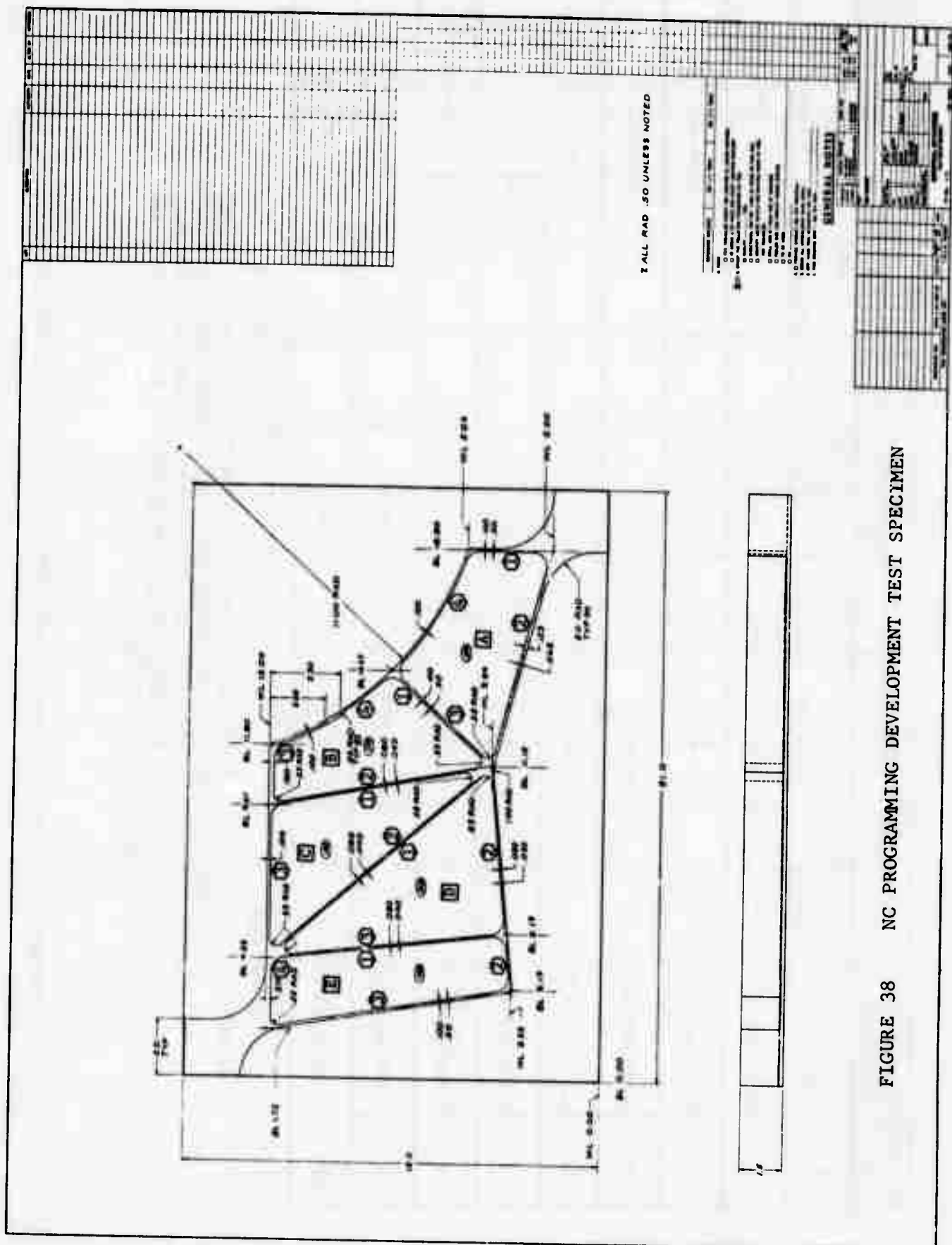

FIGURE 38 NC PROGRAMMING DEVELOPMENT TEST SPECIMEN

NC TEST NO.	PROGRAMMING APPROACH	STIFFENERS				WEBS				ALL ELEMENTS			
		-.010		0 +.010		-.010		0 +.010		-.010		0 +.010	
2	Conventional												
3	Combined R/F												
4	Combined R/F												
5	Combined R/F												
6	Separate R/F												
7	Separate R/F												
8	Combined R/F												
9	Combined R/F												
10	Separate R/F												

RANGE OF TOLERANCE RANGE OF TOLERANCE RANGE OF TOLERANCE

NOTES: - M = MEAN OF LOW END OF DIMENSIONAL DEVIATIONS SHOWN IN FIGURE
+ M = MEAN OF HIGH END OF DIMENSIONAL DEVIATIONS SHOWN IN FIGURE
- sigma = STATISTICAL STANDARD DEVIATION ABOUT - M ON LOW SIDE ONLY
+ sigma = STATISTICAL STANDARD DEVIATION ABOUT + M ON HIGH SIDE ONLY
R/F = ROUGH/FINISH MACHINING

FIGURE 39 NC PROGRAMMING DEVELOPMENT - QUALITY COMPARISON

5.2.1 (Cont'd.)

variation. The standard deviation obtained from, for example, the negative dimensional deviations was added algebraically to the negative or low mean to obtain a probable negative deviation for 68% of all parts. The same was done with the positive or high mean. The value of this can be seen by examining the range of mean deviations for all elements for S/N 3 which is well within the tolerance range; however, the standard deviation added to each of these means reveals the quality problem that really exists.

Details of the NC programming used on the ten test pieces are shown in Appendix K, Table K-1. The first part was used only for proofing the programming of S/N 2. S/N 2 was programmed by strictly conventional feed rates and cutter motion so as to provide a baseline. As can be seen in Figure 39, dimensional quality was excellent, as was surface quality, and a difficult standard was created to compete against.

S/N 3 was programmed using heavy, combined rough/finish cuts and high feed rates based on the stiffener test data and limits charts of Appendix J. Results in terms of quality were disappointing (Figure 39 and Appendix K, Figure K-6) and unacceptable. RPM was increased for S/N 4, and quality improved but was still unacceptable. Further refinements in S/N 5 improved quality to a significant degree but only by the costly expedient of lowering feed rates and increasing cutting time more than was felt necessary.

Next, separate rough and finish machining on some cuts was tried (S/N 6, 7) and quality again improved. The stiffener test data provided useful data on feed rates. A second attempt at combined rough/finish machining (S/N 8, 9) with new refinements again resulted in disappointing quality.

Finally, on S/N 10, separate rough and finish machining was used on all surfaces, and quality of all elements reached an acceptable level.

5.2.2 Webs and Corners

The most difficult elements to control were the sides. The webs on the various test specimens were generally adequate dimensionally. Roughness of webs although not as good as on S/N 2, was acceptable when judged by the newly adopted F-16 surface roughness standard (section 4.3).

A troublesome area was the 0.25 inch radius corners. The time spent in removing material with a $\frac{1}{2}$ inch diameter cutter was considered excessive, and chatter was difficult to avoid. Drilling the material out before finish machining saved no time when drilling time was added to the finish time, and surface quality was such as to require hand-finishing. As a result, drilling was abandoned. The best quality was achieved by using three passes. Examination of Appendix K, Table K-III, shows that good surface quality is often unacceptable and never excellent for a 0.25 inch corner machined with a $\frac{1}{2}$ inch diameter two inch long cutter.

5.2.3 Quality Comparison, S/N 10 vs. Baseline, S/N 2

Appendix K shows a detailed comparison in terms of quality of dimensions and surface roughness of stiffeners and webs and presents a qualitative evaluation of corner quality. The detailed inspection results are shown in Figures K-4 and K-5. Mismatches and surface roughness are compared in Tables K-IV and K-V.

A photograph of S/N 10 is presented in this report in Figure 40. An overall quality comparison is shown in Table XVII. Examination of this table shows that the less costly S/N 10 has a higher stiffener positive deviation, has larger stiffener mismatches and has a few more such mismatches than S/N 2. It has slightly lower stiffener roughness but fewer rejectable corners requiring hand-finishing. Webs on S/N 10 are of better quality dimensionally but have larger, more numerous mismatches than S/N 2. Roughness of S/N 10 webs is significantly higher than for S/N 2 due to the extremely high web finish machining feed rate; however, this roughness is not rejectable, is not damaging structurally, and does not detract noticeably from appearance.

All in all, the quality of S/N 10 is acceptable and is accompanied by a substantially lower cost.

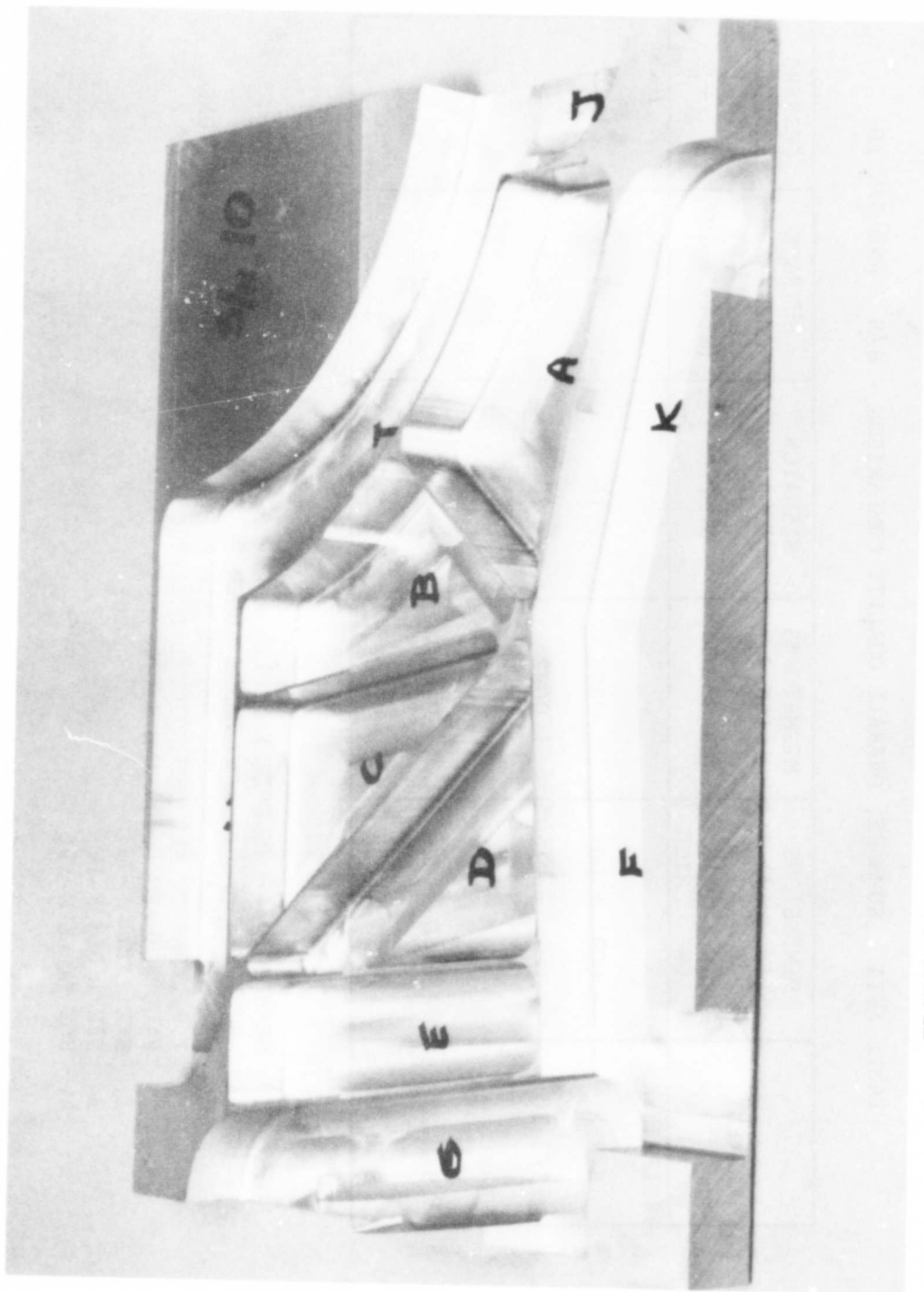

FIGURE 40 NC DEVELOPMENT TEST SPECIMEN, S/N 10

TABLE XVII SUMMARY, OVERALL QUALITY COMPARISON - S/N 2 AND S/N 10

ELEMENT	DIMENSIONS (IN.) (2) (MEAN + 1σ) (1) LOW HIGH	MISMATCHES (IN.) (3) (MEAN + 1σ)	MISMATCH OCCURRENCES (3) NUMBER	SURFACE ROUGHNESS μAA (3) (MEAN + 1σ)	CORNERS REJECTED (4)
STIFFENERS					
S/N 2	-.009 +.007	.0035	14	39.7	8
S/N 10	-.007 +.016	.0082	20	34.4	3
WEBS					
S/N 2	-.014 .000	.0047	7	38.7	
S/N 10	-.007 +.003	.0080	22	153.8	

- NOTE: 1. MEAN + 1σ SHOWS THE MEAN PLUS A REPRESENTATION OF THE VARIATION ABOUT THE MEAN. A 1σ RANGE ADDED TO THE LOW MEAN AS WELL AS TO THE HIGH MEAN INCLUDES 68% OF ALL PREDICTED DIMENSIONAL DEVIATIONS, I.E., 68% OF ALL DIMENSIONAL DEVIATIONS FROM THE NOMINAL IN S/N 2 FALL BETWEEN -.009 AND +.007.
2. SEE TABLE K-II
3. SEE TABLE K-IV
4. SEE TABLE K-III

5.2.4 Cost Reduction Indicated

Figure 41 illustrates the cutting time for each cutter for each part. During all the tests, except S/N 5, the reduction in cutting time was roughly 50% of that for the baseline, S/N 2, whether the approach was combined or separate rough and finish machining. Effort was therefore concentrated on achieving acceptable quality. The final reduction in cutting time, for S/N 10, was 54%, a good indication of the extent of reduction in cutting time that could be achieved with the guidelines developed from these tests and shown in Appendix L.

5.3 RE-PROGRAMMING F-16 PRODUCTION PARTS

Appendix L provides complete data on the results of applying the RTC NC Programming/Machining Guidelines to two F-16 parts typical of roughly half of the 60 milled aluminum parts on that airframe. Whereas the results of the development tests described in the previous section of this volume indicated a 45 - 50% reduction in cutting time, application of the guideline to the more complex production part, 16B5222, shown in Figure 42, resulted in almost 70% reduction in cutting time. This, in turn, resulted in an average reduction in total time on the machine - including set-up, tear down, etc. - of 46% for the seven pieces machined.

The second part re-programmed, Figure 43, was not done with full compliance to the guidelines. Consequently, reduction in cutting time was only 53%, and total time on the machine was reduced 36% - still a respectable reduction.

As will be seen in the following discussion, the cost-reductions achieved did not result in lowered quality. In addition, the shop welcomed the features permitting the operator to let the NC tape run the machine without operator responsibility for tape over-ride and having the machine RPM stipulated on the operator's instructions.

CUTTER DIA.	SPECIMEN NO.																							
	#2	#3	#4	#5	#6	#7	#8	#9	#10															
	CUTTER TIME (MINUTES)																							
DRILL	0	5	10	0	5	10	0	5	10	0	5	10	0	5	10	0	5	10	0	5	10			
2"	8.8 min. 15.6%	3.1 11.7	3.1 11.7	7.8 21.3	3.0 11.2	3.7 min. 13.8%	4.8 18.3	4.1 16.7	4.1 16.7	5.0 19.0	4.1 16.7	4.1 16.7	4.1 16.7	4.1 16.7	5.4 21.1	4.1 16.7	4.1 16.7	4.1 16.7	4.1 16.7	5.4 21.1	4.1 16.7	4.1 16.7	5.4 21.1	
1½"	13.6 min. 24.3%	10.6 40.1	10.6 40.1	13.3 36.3	10.6 39.3	8.5 32.7	10.8 44.1	10.8 44.1	10.8 44.1	10.8 44.1	10.8 44.1	10.8 44.1	10.8 44.1	10.8 44.1	10.5 41.0	10.8 43.9	10.8 43.9	10.8 43.9	10.8 43.9	10.5 41.0	10.8 43.9	10.8 43.9	10.5 41.0	
1"	15.1 min. 27.0%	3.3 12.6	3.3 12.6	3.8 10.2	3.0 11.2	3.1 11.7	3.0 12.2	3.0 12.2	3.0 12.2	3.1 11.7	3.0 12.2	3.0 12.2	3.0 12.2	3.0 12.2	3.0 12.2	3.0 12.2	3.0 12.2	3.0 12.2	3.0 12.2	3.0 12.2	3.0 12.2	3.0 12.2	3.0 12.2	3.0 12.2
½"	18.5 min. 33.1%	9.5 35.6	9.5 35.6	11.8 32.2	6.6 24.5	4.8 18.3	6.6 26.9	6.6 26.9	6.6 26.9	4.8 18.3	6.6 26.9	6.6 26.9	6.6 26.9	6.6 26.9	6.7 27.2	6.7 27.2	6.7 27.2	6.7 27.2	6.7 27.2	6.7 27.2	6.7 27.2	6.7 27.2	6.7 27.2	6.7 27.2
TOTAL MIN.	55.9	26.5	26.5	36.7	26.9	26.0	24.5	24.5	24.5	26.0	24.5	24.5	24.5	24.5	25.6	24.6	24.6	24.6	24.6	25.6	24.6	24.6	25.6	

FIGURE 41 NC PROGRAMMING DEVELOPMENT TESTS - CUTTER TIME VARIATIONS

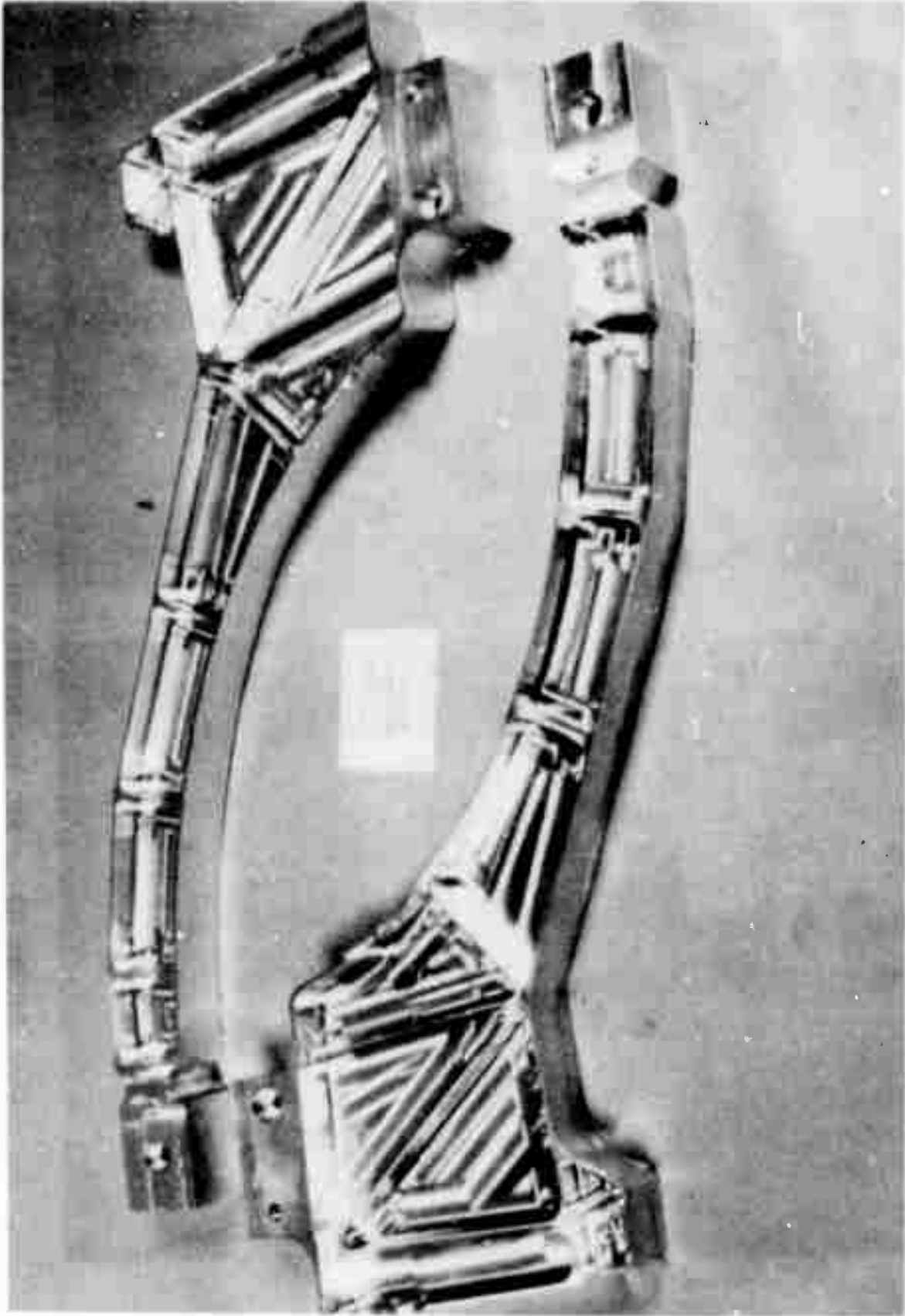

FIGURE 42 RTC RE-PROGRAMMED F-16 PART - 16B5222

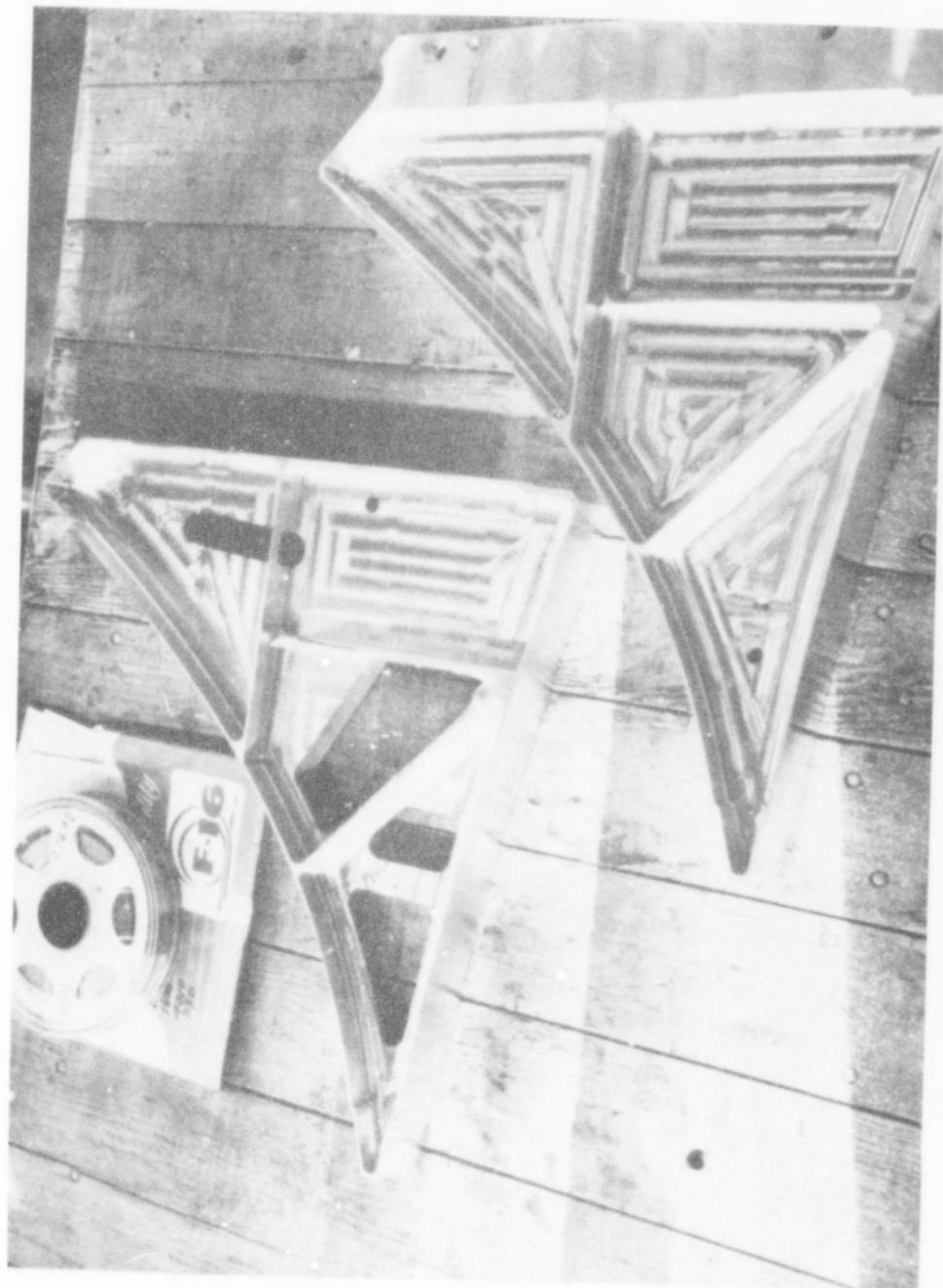

FIGURE 43 RTC RE-PROGRAMMED F-16 PART - 16B1262

5.3 (Cont'd.)

The guidelines are presented in their entirety in Appendix L. Guideline departures from conventional programming are neither extreme nor revolutionary. Their acceptability to F-16 programmers was demonstrated by the immediate adoption of the tapes for the two re-programmed parts for F-16 production use.

5.3.1 Effect of Guidelines on Metal Removal Rates

Table XVIII compares cuts, feed rates and metal removal rates for conventional programming with those derived from the NC development tests. These features and values were eventually incorporated into the guidelines for the first production part. The stiffener tests showed that heavy metal removal rates were possible without machine or cutter overload and without metallurgical damage. Rough machining takes roughly half of the total cutting time, so an increase in feed rate of 100% permitted a 25% time reduction. Such a reduction, and more, was realized for slotting, ramping, roughing and web finish machining. Finish machining was increased 80% for the sides. Machining of the 0.50 inch corners with the one inch cutter and the 0.25 inch corners with the $\frac{1}{2}$ inch cutter could not be increased in metal removal rate over the conventional rate without damaging the surface by inducing chatter; however, the approach speeds and traversing of the corners was improved.

Rapid traversing was increased in velocity, and the cutter reference point was located such as to reduce rapid traverse distance.

The power required for the heavier roughing cuts reached a momentary 26 hp, of which 10 was required for the free rotating spindle. Machine shop supervision was asked to witness the rough cutting and expressed satisfaction with the demand on the machine as not being excessive.

The net result of reprogramming the first production part was a substantial increase in the average metal removal rate of over 100% leading to an unexpectedly large reduction in cutting time which is discussed in the following section.

TABLE XVIII TYPICAL NC PROGRAMMING COMPARISON

P/N 16B5222-7 MATERIAL: 2124-T851

CUTTER DIAMETER (in.)	CUTTER OPERATION	PRODUCTION PROGRAMMING (ALL CUTTERS @ 1800 RPM)					RTC PROGRAMMING					$\frac{M2}{M1}$
		dA	dR	A	f	M1	dA	dR	A	f	M2	
2.0	Slot cut down to top of stiffeners	0.5	2.0	1.0	18	18.0	0.5	2.0	1.0	40	40	2.2
1.5	Ramp into pockets	1.0	1.5	1.5	5	8.0	1.0	1.5	1.5	15	22.5	2.8
	Rough machining	1.0	.75	.75	20	15.0	1.0	.75	.75	40	30	2.0
	Finish web	.05	1.5	.075	20	1.5	.03	1.5	.045	75	3.4	2.3
1.0	Finish sides	1.0	.05	.05	20	1.0	1.0	.05	.05	35	1.8	1.8
	Finish corners	1.0	1.0	1.0	3	3.0	1.0	1.0	1.0	3	3.0	1.0
0.5	Approach corners	1.0	.5	.5	5	2.5	1.0	.5	.5	10	5.0	2.0
	Finish corners	1.0	.5	.5	3	1.5	1.0	.5	.5	3	1.5	1.0
1" cone	Mill 40-30' sides	1.0	.04	.04	20	.8	1.0	.04	.04			
	Rapid traverse x&y	70					95					
	Rapid traverse z	50					50					

Notes: $M = d_A \times d_R \times f$ where M = metal removal rate, cu. in./min.
 d_A = axial cut, in.
 d_R = radial cut, in.
 f = feed rate, in./min.

5.3.2 Effect of Guidelines on Cutting Time

Table XIX lists the time required for each function for each of the seven pieces machined with re-programmed tape for the first F-16 part, 16B5222-7. The wide variation in set-up and tear down is the result of shop scheduling, i.e., two pieces machined one after the other used the same tool set-up. Tooling time was occasionally high because tooling was often removed to make room for another part.

Cutter and clamp changes profited from learning, so time decreased for each piece. Cutting time varied somewhat due to minor program changes.

The column called "Actual Production Cutting Time" is shown with a constant time of 206.1 minutes. This was the production tape time. In reality, the cutting time varied for each part due to operator over-ride which also means that every production part took more than 206.1 minutes; therefore, the time listed is conservatively low by as much as 10-20%.

Since there was no difference in tooling and cutter sizes between the production and the RTC operations, the actual, measured RTC time was assumed equally applicable to the production operation, and the total time on the machine was thus calculated.

5.3.3 Effect of Guidelines on Quality

Table XX shows a breakdown of the Quality Assurance department inspection results on 16B5222-7 for three recent, randomly selected production pieces and for the seven pieces machined by RTC. The biggest quality problem encountered in re-programming was not the effect of the guidelines but, instead, was programming/machine operator errors unrelated to the RTC features. This was common to both production and RTC operations as can be seen with the second production part and the first and second RTC parts. Tape errors existed in all the parts; however, usually, engineering is able to judge these errors as not sufficiently serious to require scrapping of the part. Repairs, however, are expensive. The second RTC part cost doubled due to the repair that was found necessary. Schedule need demanded a repair despite the cost.

5.3.3 (Cont'd.)

The one discrepancy that was considered related to the programming was the dimensional. The first three RTC pieces had more of these than was considered desirable for a demonstration part, so small program changes were made and the results improved. The guidelines were adjusted accordingly.

Surface roughness, i.e., "waviness," were, strictly speaking, not a rejectable item according to the RTC-revised inspection standard, but good surface quality was still a desired objective and the result was therefore recorded.

All in all, the quality of the RTC pieces was comparable to production pieces.

5.3.4 Significance of Cutting Time Reduction

The reduction in cutting time is a quantity controlled entirely by the NC tape as long as the operator finds no need to over-ride the tape; therefore, learning influences play no part. As learning continues to effect reduction in total machined part cost, the cutting time will become a continuously increasing and important portion of total cost. For example, the 2.2 hours saved in cutting time on 16B5222-7 is roughly 5% of current F-16 manhour total cost. By the 1000th unit, the same 2.2 hours will be approximately 20% of total cost.

Furthermore, if savings encountered in the two parts that were re-programmed to the guidelines, are typical of the 50% of all F-16 machined parts that are considered potential candidates for re-programming, some benefit should also be felt in terms of work force and capital equipment needs.

5.3.5 Re-Programming/Machining of Second F-16 Production Part

Tables XXI, XXII and XXIII describe the programming, machining time comparison and quality comparison between RTC and conventional production machining. The discussion submitted in the preceding paragraphs for the first re-programmed part is fully applicable here. The lesser cutting time saving of 53% and in total time average of 36% is partly due to the nature of the design (more small corner radii than on most F-16 parts) and selection of a 1½ inch cutter instead of the more efficient 2 inch cutter for rough machining; however, some variation in effectiveness of guideline application must be expected, which is one reason why this part was selected.

TABLE XIX MACHINING TIME COMPARISON - 16B5222-7

S/N (1)	TIME, IN MINUTES					COMPARISON, TOTAL TIME		
	TOOL SETUP, TEAR-DOWN (2)	CUTTER, CLAMP CHG'S (3)	ACTUAL RTC CUTTING TIME (4)	ACTUAL PRODUCTION CUTTING TIME (5)	MINUTES		RTC % OF PROD. (8) (6)/(7)	
					RTC (6) (2)+(3)+(4)	PROD. (7) (2)+(3)+(5)		
001	120.0	42.9	63.6	206.1	226.5	369.0	61%	
002	119.0	29.0	60.5	206.1	208.5	354.1	59	
003	40.0 ①	27.6	61.0	206.1	128.6	273.7	47	
004	122.6	22.2	62.9	206.1	207.7	350.9	59	
005	40.0 ①	17.6	62.9	206.1	120.5	263.7	46	
006	75.7	11.5	65.9	206.1	153.10	293.3	52	
007	②	②	71.6	206.1	—	—	—	
MEAN			64.1		174.1	317.5	54	

Notes: ① Tooling was in place from previous S/N.
 ② Data was not measured.

TABLE XX QUALITY COMPARISON - 16B5222-7

SERIAL NO.	QAR NO.	NUMBER & TYPES OF DISCREPANCIES				COMMENTS
		DIMENSIONAL	SURFACE	DAMAGE	OTHER	
F207460 F-16 Prod. Part	AK47559 16 rejections	15	0	0	1 tape error	8 items - use as is 3 items - rework 4 items - smooth & use
F449945 F-16 Prod. Part	AK47661 9 rejections	5	0	1	2 tape errors	1 item - doubler repair 4 items - use as is 2 items - rework
F207462 F-16 Prod. Part	AK47537	9	1 (cutter run in radius)	0	2 tape errors	7 items - use as is 3 items - rework
F455337 RTC Part S/N 1	AK47702 35 rejections	24	0	1 (web cut thru)*	5 axis tape error	*Tape error-scrapped part. (Used on metal mockup)
F455333 RTC Part S/N 2	AK35278 19 rejections	14	0	1 (rib cut thru)*	5 axis tape error	*Tape error-repaired. Added to F-16 production stock. 14 items - use as is. 3 items - rework to B/P
F455335 RTC Part S/N 3	AK35452 16 rejections	10	2 (excessive waviness)	-	5 axis tape error	10 items - use as is 4 items - rework to B/P 2 items - smooth & use Added to production stock.
F455334 RTC Part S/N 4	AK35399 11 rejections	8	1 (excessive waviness)	-	5 axis tape error	8 items - use as is 3 items - rework to B/P Added to production stock.
F455336 RTC Part S/N 5	AK23950 9 rejections	8	0	-	5 axis tape error	5 items - use as is 3 items - rework to B/P 1 item - smooth and use Added to production stock.
F460852 RTC Part S/N 6	AK28451 16 rejections	13	2 (chatter marks)	-	5 axis tape error	13 items - use as is 2 items - rework to B/P 1 item - smooth & use Added to production stock.
F460853 RTC Part S/N 7	AK28379 7 rejections	6	0	-	5 axis tape error	2 items - use as is 3 items - rework to B/P 2 items - smooth & use Added to production stock.

TABLE XXI TYPICAL NC PROGRAMMING COMPARISON

P/N 16B1262-23 MATERIAL: 2124-T851

CUTTER DIAMETER (in.)	CUTTER OPERATION	PRODUCTION PROGRAMMING (ALL CUTTERS @ 1800 RPM)					RTC PROGRAMMING					$\frac{M2}{M1}$
		dA	dR	A	F	M1	dA	dR	A	F	M2	
1.25	Ramp into pockets	1.0	1.25	1.25	10	12.5	1.0	1.25	1.25	15	18.8	1.5
	Rough machining	1.0	.6	.60	20	12.0	1.0	.6	40	24	2.0	
	Finish web	.05	1.25	.063	20	1.3	.03	1.25	75	2.8	2.2	
0.75	Finish sides	1.0	.05	.05	20	1.0	1.0	.05	35	1.8	1.8	
	Finish corners	1.0	.75	.75	3	2.3	1.0	0.75	3	2.3	1.0	
0.5	Approach corners	1.0	.5	.5	10	5	1.0	.5	10	5.0	1.0	
	Finish corners	1.0	.5	.5	3	1.5	1.0	.5	3	1.5	1.0	
0.75 cone	86° wall	1.0	.04	.04	20	.8	1.0	.04	20	.8	1.0	
	Rapid traverse x&y Rapid traverse z				70 50				95 50			

Notes: $M = dA \times dR \times f$ where

M = metal removal rate, cu. in./min.

dA = axial cut, in.

dR = radial cut, in.

f = feed rate, in./min.

$A = dA \times dR$

TABLE XXII MACHINING TIME COMPARISON - 16B1262

S/N (1)	TIME, IN MINUTES ON 3 AXIS MILL					COMPARISON, TOTAL TIME		RTC % OF PROD. (8) (6)/(7)
	TOOL SETUP, TEAR-DOWN (2)	CUTTER, CLAMP CHG'S. (3)	ACTUAL CUTTING TIME (4) ③	ACTUAL PRODUCTION CUTTING TIME (5) ③ ④	MINUTES		PRODUCTION (7) (2)+(3)+(5)	
					RTC (6) (2)+(3)+(4)	DATA INVALID ⑤		
F463031	(180) ②	(10.5)	(120.33)	119.7	99.90	159.9	-	
F463033	30.2	10.0	59.7	119.7	74.8	137.6	62%	
F436034	8.1 ①	9.8	56.9	119.7	74.0	145.8	54	
F463035	8.4 ①	9.3	56.3	119.7	248.6	311.7	51	
F219521A	182.0 ②	10.0	56.6	119.7	74.9	140.2	80	
F471743	9.2 ①	11.3	54.4	119.7	114.4	179.0	53	
			56.8 (47%) (-53%)	119.7			64% (-36%)	

- NOTES: ①
②
③
④
⑤

Tooling was in place from previous part.
Tooling was removed, and re-installed after machining other parts.
Three-axis time, only, is reported. Five-axis time is code minutes, not re-programmed,
is used for cutting periphery to size.
Conservatively reported. Conventional running time is always higher than tape due to
operator over-ride.
NC machine ran slower than tape at 100%, needed repair. Also, programming not to
guidelines.

TABLE XXIII QUALITY COMPARISON, 16B1262

PART NO.	SERIAL NO.	QAR NO.	NUMBER & TYPES OF DISCREPANCIES				COMMENTS
			DIMENSIONAL	SURFACE	DAMAGE	OTHER	
16B1262-13	F426528 Prod. Part	AK23515 12 Rejections	9	0	1	2 Mislocated Cut	Morey #4 mill malfunctioned Part scrapped
16B1262-13	F426530 Prod. Part	AK23585 7 Rejections	6	0	0	1 Mislocated Cut	6 Items - Use as is 1 Item - Rework to B/P
16B1262-13	F426529 Prod. Part	AK23586 7 Rejections	6	0	0	1 Mislocated Cut	6 Items - Use as is 1 Item - Rework to B/P
16B1262-21	F219521 Prod. Part	AK28156 5 Rejections	5	0	0	0	5 Items - Use as is 1 Item - Smooth and use
16B1262-21	F463031 RTC S/N 001	AK28054 11 Rejections	7	0	0	4 Part was milled to a -15 tape	4 Items - Rework to B/P 2 Items - Rework to -21 & use 3 Items - Use as is 1 Item - Smooth & use
16B1262-21	F463033 RTC S/N 003	AK47466 10 Rejections	7	2	5	Hole not cut clear thru web	2 Items - Use as is 5 Items - Rework to B/P 1 Item - Break sharp edges and smooth & use 2 Items - Smooth & use
16B1262-21	F463034 RTC S/N 004	AK53952	8	1	1	0	Part scrapped. Machine malfunctioned.
16B1262-23	F463035 RTC S/N 005	FAI 3/31/77 See Note (1)	4	0	0	0	
16B1262-23	F219521A RTC S/N 006	None	0	0	0	0	Tape acceptable for production.
16B1262-23	F471743 RTC S/N 007		4	0	0	0	Tooling positioning error. Status unresolved at time of this report.

NOTES: (1) FAI is "First Article Inspection" record, conducted to proof tape before formal inspection.

6. I M P L E M E N T A T I O N

Implementation of program findings was aided by involving the same functional groups in data development that would eventually be the users of the findings.

The dimensional and design relaxation resulting from the survey of machine shop capability were coordinated with and reviewed by F-16 stress analysts, designers and weights engineers and were adopted across the board on all F-16 machined parts. The design guidelines were similarly coordinated and found acceptable. Most of the RTC relaxations to engineering requirements were issued over the F-16 Chief Engineer's signature as recommendations to the F-16 engineering staff. In addition, these findings were incorporated in the GD/FWD Design Manual

Relaxation of roughness and hand finishing requirements were implemented by repeated coordinating sessions with inspection, machine shop, process control, planning, materials engineering, stress analysis and airframe design representatives. Extensive revisions were made to the F-16 hand finish standard. Classes were taught by RTC personnel to all machine shop, assembly and inspection personnel, including their supervision, to aid in interpretation of the revisions to the standard.

Implementation of NC programming changes was more difficult. Manufacturing Engineering and F-16 NC production programmers played a major role in developing the guidelines, and there was general agreement that the guidelines were practical and usable; however, the work was done at a time of great schedule pressure due to F-16 start-up problems, so guideline development lagged the initial programming of F-16 parts. The two NC programs that were developed according to the guidelines were adopted for F-16 production, but implementation across the board had to await future opportunities to re-program parts. Nevertheless, the objectives were met in terms of cost reduction on the parts that were re-programmed, and it can be assumed that further implementation will take place on a timely, cost-effective basis with similar cost reductions.

7. COST REDUCTION ANALYSIS

In order to lend credibility and objectivity to any claims of cost reduction, the GD/FWD Value Engineering Group was asked to examine the limited cost data generated thus far by the F-16 program.

7.1 GUIDELINE EFFECTIVITY

The guidelines for design and surface roughness/hand-finishing had been in effect from the very beginning of Full Scale Development (FSD), so it was hoped that despite the difficulties of production start-up, some indication of cost reduction might be found. The NC programming guidelines were developed much later, so no indications were expected from factory cost records although the verified reductions in machining time for the two production parts that were re-programmed were considered hard data.

7.2 BASELINE AND F-16 COST DATA SOURCES

The baseline for comparison was the F-111 cost data records from the hand-finishing department and the total cost recorded for machined aluminum parts. Since the F-111 was a larger aircraft, the F-111 parts examined in terms of total cost were restricted to those with a weight no more than those for the F-16.

7.3 HAND-FINISH COST COMPARISON

From the above data sources, 23 F-111 parts consisting of 1,242 pieces of milled aluminum were compared with 60 F-16 parts with 450 pieces. For each group, hand-finish manhours were determined as a percentage of total manhour cost. The F-111 parts required 18.4% and the F-16 parts 14.3%, a reduction of 22.3% for the F-16 parts. This reduction amounts to 5% of total cost.

For a sample size of this magnitude, there is no available explanation for such a large difference in hand-finishing except that there is less hand-finishing being done. Furthermore, this reduction is at a time when NC programming is still being worked to ferret out dimensional discrepancies which are being corrected

on the machined parts by hand-finishing. Learning curve corrections to standardize the two sets of data would have no influence on a percentage-type comparison. Processing of parts is almost identical, and machine shop equipment has not been improved as yet.

In view of the above status, it is expected that the saving in hand-finishing cost will increase further, to a substantially larger percentage.

7.4 TOTAL COST COMPARISON

After adjusting F-16 and F-111 total costs for learning curve effects, the mean total cost for 207 pieces for 28 F-16 parts was compared to comparable F-111 costs. The F-16 parts were found to be 9% less than the F-111 parts in total cost. It was established above, that hand-finishing differences reduced total cost by 5%, so other sources must have been responsible for 4%.

To claim that as small a difference as 4% is due to RTC design guidelines requires some examination; however, nothing is very different in the F-16 machining operation from that of the F-111. The same equipment and personnel are in use. The same NC programming/machining metal removal rates are in use. Processes are identical except that instead of shot-peening a few critical F-111 parts, all F-16 aluminum machined parts are now put through pre-penetrant etch. The only difference of significance is that flange/stiffener dimensional tolerances have been increased by 50% and almost all machined pockets have larger corner radii permitting quicker, easier machining. Other design guidelines have lesser benefits, being less generally applicable. These relaxations have an unquestionable, quantitative effect on cost, so, for lack of any other beneficial impact, it is not unreasonable to attribute the 4% cost reduction to these influences until further data becomes available.

7.5 NC RE-PROGRAMMING EFFECT ON COST

No cost reduction due to higher metal removal rates would be evident from F-16 cost records since only two parts were re-programmed to the NC programming/machining guidelines; however, certain data can be used for making a projection of cost reduction.

The RTC NC programming approach requires no operator control of feedrates, so any reduction in cutting time is constant and repetitive, and unaffected by learning. Of the approximately 60 machined aluminum parts on the F-16, at least half are candidates for re-programming.

Re-programming of the first of the two parts examined, 16B5222-7, resulted in a cutting time reduction of 2.24 hours. The estimated average unit cost for 1000 pieces of 16B5222-7 is 15.10 manhours. The percentage cost reduction would therefore be $2.24/15.10$ or 14.8%.

Although the second part, 16B1262-21, was not re-programmed in full compliance with the guidelines, cutting time was still reduced by 1.02 hours. The estimated average unit cost for 1000 pieces of 16B1262-21 is 14.64 manhours. The percentage cost reduction would then be $1.02/14.64$ or 7.0%.

Assuming that the average of these two percentage reductions is applicable to the 30 candidate parts, the average percentage reduction for all 60 parts would then be roughly $(30/60) (14.8 + 7.0) \times \frac{1}{2}$ or 5.45%.

7.6 TOTAL ESTIMATED COST REDUCTION

If one accepts the above rationalization, the cost reduction indicated on the F-16 machined aluminum airframe parts would summarize as follows:

Hand-finish spec relaxations	- 5%
Design relaxations	- 4%
NC programming/machining guidelines	<u>- 5%</u>
Total estimate	-14%

Every attempt has been made to be conservative in estimating these costs; however, it remains to be seen just how cost-effective the implemented relaxations eventually become.

8. REFERENCES

1. Richards, Cedric W., "Engineering Materials Science," Wadsworth Publishing Co., Inc., 1961
2. 1976 Annual Book of ASTM Standards, Part 10, Metals-Mechanical, Fracture, and Corrosion Testing; Fatigue; Erosion; Effect of Temperature
3. Koster, W. P., et al, "Surface Integrity of Machined Materials," pp. 146-147, AFML-TR-74-60, Metcut Research Associates, Inc., 1974

THIS REPORT HAS BEEN DELIMITED
AND CLEARED FOR PUBLIC RELEASE
UNDER DOD DIRECTIVE 5200.20 AND
NO RESTRICTIONS ARE IMPOSED UPON
ITS USE AND DISCLOSURE.

DISTRIBUTION STATEMENT A

APPROVED FOR PUBLIC RELEASE;
DISTRIBUTION UNLIMITED.