

UNCLASSIFIED

AD NUMBER

ADB048811

LIMITATION CHANGES

TO:

Approved for public release; distribution is unlimited. Document partially illegible.

FROM:

Distribution authorized to U.S. Gov't. agencies only; Test and Evaluation; MAR 1980. Other requests shall be referred to National Aeronautics and Space Administration, PM, GFRAP, Langley Research Center, Hampton, VA 23665. Document partially illegible.

AUTHORITY

nasa, ltr, 17 sep 1980

THIS PAGE IS UNCLASSIFIED

AD-B 048 811

USADAC TECHNICAL LIBRARY



5 0712 01018069 2

TECHNICAL LIBRARY

AD

MEMORANDUM REPORT ARBRL-MR-02946

CARBON FIBER TRANSFER FUNCTIONS THROUGH FILTERS AND ENCLOSURES

John J. Paszek
Dudley D. Davis
James H. Patrick

19971009 222

March 1980



US ARMY ARMAMENT RESEARCH AND DEVELOPMENT COMMAND
BALLISTIC RESEARCH LABORATORY
ABERDEEN PROVING GROUND, MARYLAND

Distribution limited to US Government agencies only;
Test and Evaluation; Mar 1980. Other requests for
this document must be referred to PM, GFRAP, NASA
Langley Research Center, Hampton, VA 23665.

DTIC QUALITY INSPECTED 3

Destroy this report when it is no longer needed.
Do not return it to the originator.

Secondary distribution of this report by originating
or sponsoring activity is prohibited.

Additional copies of this report may be obtained
from the Defense Technical Information Center, Cameron
Station, Alexandria, Virginia 22314.

The findings in this report are not to be construed as
an official Department of the Army position, unless
so designated by other authorized documents.

*The use of trade names or manufacturers' names in this report
does not constitute indorsement of any commercial product.*

THIS REPORT HAS BEEN DOWNGRADED
AND CLEARED FOR PUBLIC RELEASE
UNDER DOD DIRECTIVE 5200.10 AND
NO RESTRICTIONS ARE IMPOSED UPON
ITS USE AND DISCLOSURE.

DISTRIBUTION STATEMENT A
(APPROVED FOR PUBLIC RELEASE)
DISTRIBUTION UNLIMITED.

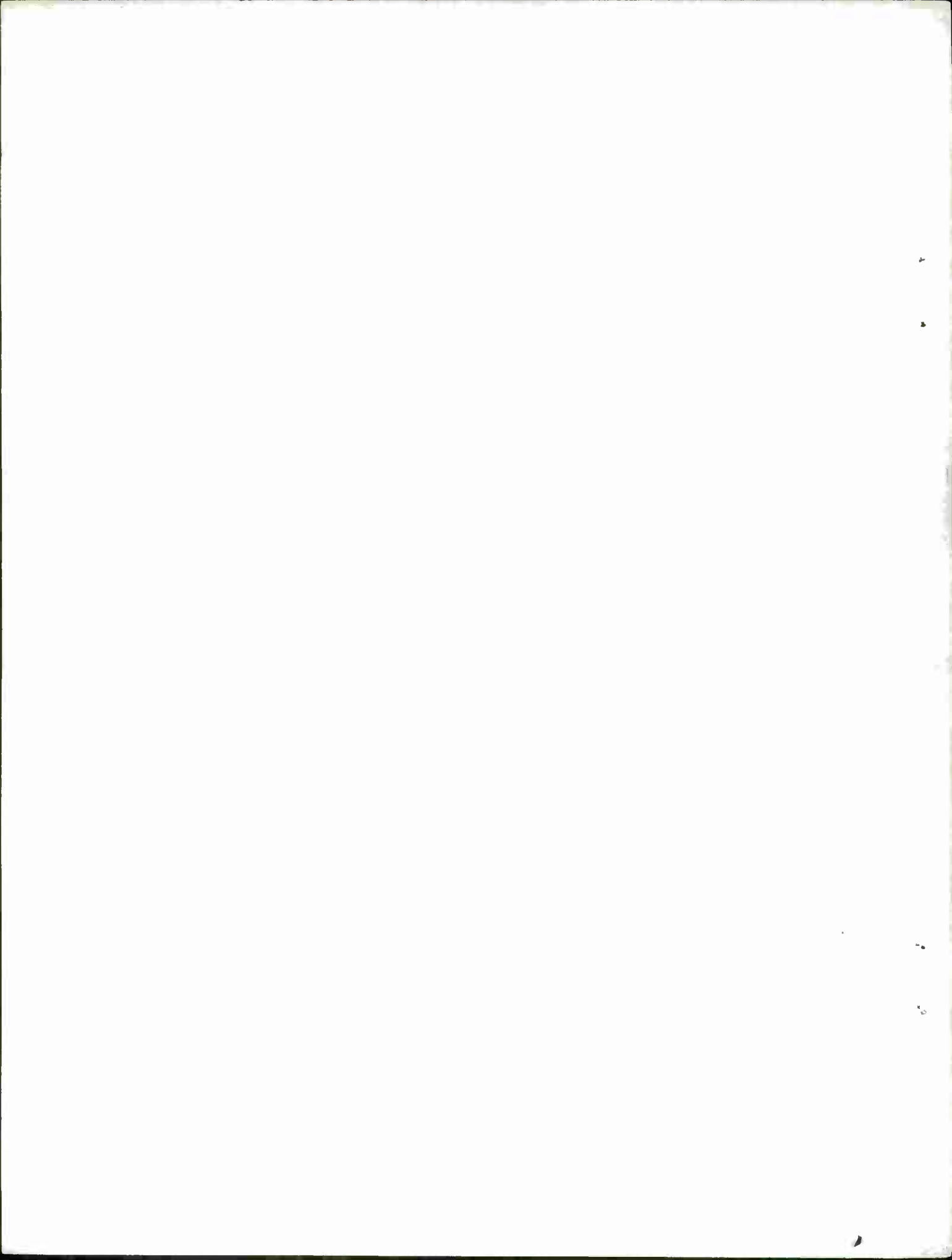

TABLE OF CONTENTS

	Page
LIST OF ILLUSTRATIONS.....	5
LIST OF TABLES.....	7
I. INTRODUCTION.....	9
II. FILTER TESTS.....	9
A. Test Facilities and Procedures.....	9
1. Test Facilities.....	9
a. Test Chamber.....	9
b. Fiber Disseminator.....	9
c. Filter Test Fixture.....	9
2. Measurements.....	12
a. Concentration and Exposure as a Function of Time.....	12
b. Filter Transmission Factor as a Function of Exposure.....	13
c. Fiber Length Distribution.....	13
d. Air Flow Rate and Pressure Differential.....	13
3. Test and Cleanup Procedures.....	13
B. Specimen Filters - Description, Preparation, and Test Results.....	14
1. Fiberglass Furnace Filters.....	14
a. Description.....	14
b. Preparation.....	14
c. Test Results.....	14

TABLE OF CONTENTS (Con't)

	Page
2. Pleated Panel Filters.....	18
a. Description.....	18
b. Preparation.....	18
c. Test Results.....	18
3. Window Screen.....	23
a. Description.....	23
b. Preparation.....	23
c. Test Results.....	23
4. Room Air Conditioner Filters.....	23
a. Description.....	23
b. Preparation.....	23
c. Test Results.....	23
III. AIR CONDITIONING DUCT TESTS.....	28
A. Description of Tests.....	28
B. Results.....	28
IV. GENERIC CABINET TESTS.....	28
A. Description of the Tests.....	28
B. Results.....	36
V. SUMMARY.....	39
ACKNOWLEDGEMENTS.....	41
DISTRIBUTION LIST.....	43

LIST OF ILLUSTRATIONS

Figure		Page
1.	FILTER TEST FIXTURE.....	11
2.	TYPICAL UPSTREAM CONCENTRATION AND EXPOSURE PLOT FOR FURNACE FILTER TESTS.....	19
3.	TYPICAL DOWNSTREAM CONCENTRATION AND EXPOSURE PLOT FOR FURNACE FILTER TESTS.....	20
4.	TYPICAL LENGTH DISTRIBUTIONS FOR FURNACE FILTER TESTS.....	21
5.	TYPICAL UPSTREAM CONCENTRATION AND EXPOSURE PLOT FOR WINDOW SCREEN TESTS.....	25
6.	TYPICAL DOWNSTREAM CONCENTRATION AND EXPOSURE PLOT FOR WINDOW SCREEN TESTS.....	26
7.	TYPICAL LENGTH DISTRIBUTIONS FOR WINDOW SCREEN TESTS.....	27
8.	TYPICAL UPSTREAM CONCENTRATION AND EXPOSURE PLOT FOR AIR CONDITIONER FILTER.....	31
9.	TYPICAL DOWNSTREAM CONCENTRATION AND EXPOSURE PLOT FOR AIR CONDITIONER FILTER TESTS.....	32
10.	TYPICAL LENGTH DISTRIBUTIONS FOR AIR CONDITIONER FILTER TESTS.....	33
11.	EXPERIMENTAL APPARATUS FOR FIBER BREAKUP TESTS.....	34

LIST OF TABLES

Table		Page
I.	FILTER TRANSMISSION RESULTS.....	15
II.	FILTER TRANSMISSION RESULTS.....	16
III.	FILTER TRANSMISSION RESULTS.....	17
IV.	FILTER TRANSMISSION RESULTS.....	22
V.	FILTER TRANSMISSION RESULTS.....	24
VI.	FILTER TRANSMISSION RESULTS.....	29
VII.	FILTER TRANSMISSION RESULTS.....	30
VIII.	DUCT TESTS LENGTH DATA SUMMARY.....	35
IX.	TRANSFER FUNCTION - GENERIC CABINET.....	37
X.	TRANSFER FUNCTION - GENERIC CABINET.....	38
XI.	TRANSFER FUNCTION - GENERIC CABINET.....	40

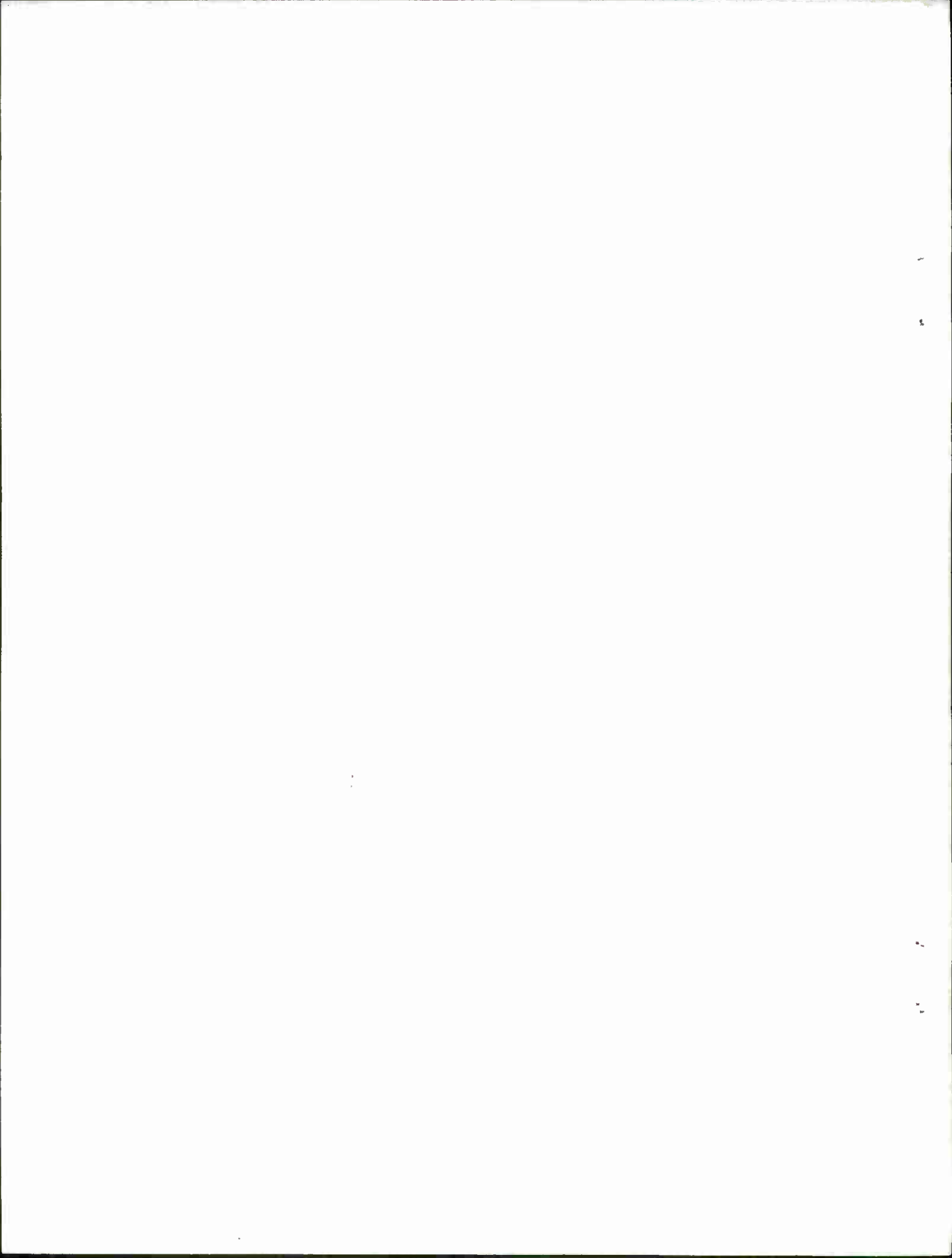

I. INTRODUCTION

Carbon fibers are electrically conducting. When electrical equipment is operated in a carbon fiber laden environment, fibers may enter the equipment, bridge electrical gaps and cause malfunctions. The number of fibers entering the equipment is a direct function of the environmental exposure and any medium which intervenes the equipment and its environment. An example of such a medium is an air filter. This report gives experimentally determined transfer functions for air filters, air conditioning duct work, and equipment cabinets.

II. FILTER TESTS

A. Test Facilities and Procedures

1. Test Facilities.

a. Test Chamber. The filter transmission tests were performed inside the S-280 electrical equipment shelter (ECOM chamber) which is an air tight enclosure fitted with a tight sealing door. The walls, ceiling, and floor are all smooth surfaces, which facilitate cleaning between tests. Interior dimensions are 3.5 m long, 2.1 m wide, and 1.9 m high. Inside the chamber, 12 muffin fans, placed in as many locations, act to keep introduced fibers suspended in the chamber air.

b. Fiber Disseminator. The BRL Fiber Disseminator¹ was used to fill the chamber with a cloud of single fibers. The disseminator is a tubular vertical column 15 cm in diameter and 1 m high; it is powered by compressed air. Two independent air streams separate the fibers, disperse them throughout the air in the column, and finally inject them into the test chamber. One air stream is continuous and provides a gentle current of air up the column and out of the top through a small opening. The other air stream is intermittent; periodic short blasts of air lift small clumps of fibers from the fiber reservoir at the bottom upward into the column where they are gently agitated and separated. Single fibers continue rising with the upward air current until they are ejected at the top; remaining small clumps of fibers drift downward back into the reservoir. The intermittent air blast is provided by an electrical solenoid valve controlled by a timer, and both the duration of the blast and the interval between blasts are adjustable. With the disseminator, the concentration of fibers in the chamber can be controlled over a large range ($5 \times 10^5 - 2 \times 10^5$ f/m³) and held constant for a long period of time (~ 30 min).

c. Filter Test Fixture. The specimen filter was mounted in a tubular test fixture that provided a controllable air flow through the filter. The fixture is 15 cm in diameter and 2 m long (see Figure 1) and consists

¹Neil Wolfe, private communication, "The BRL Fiber Disseminator".

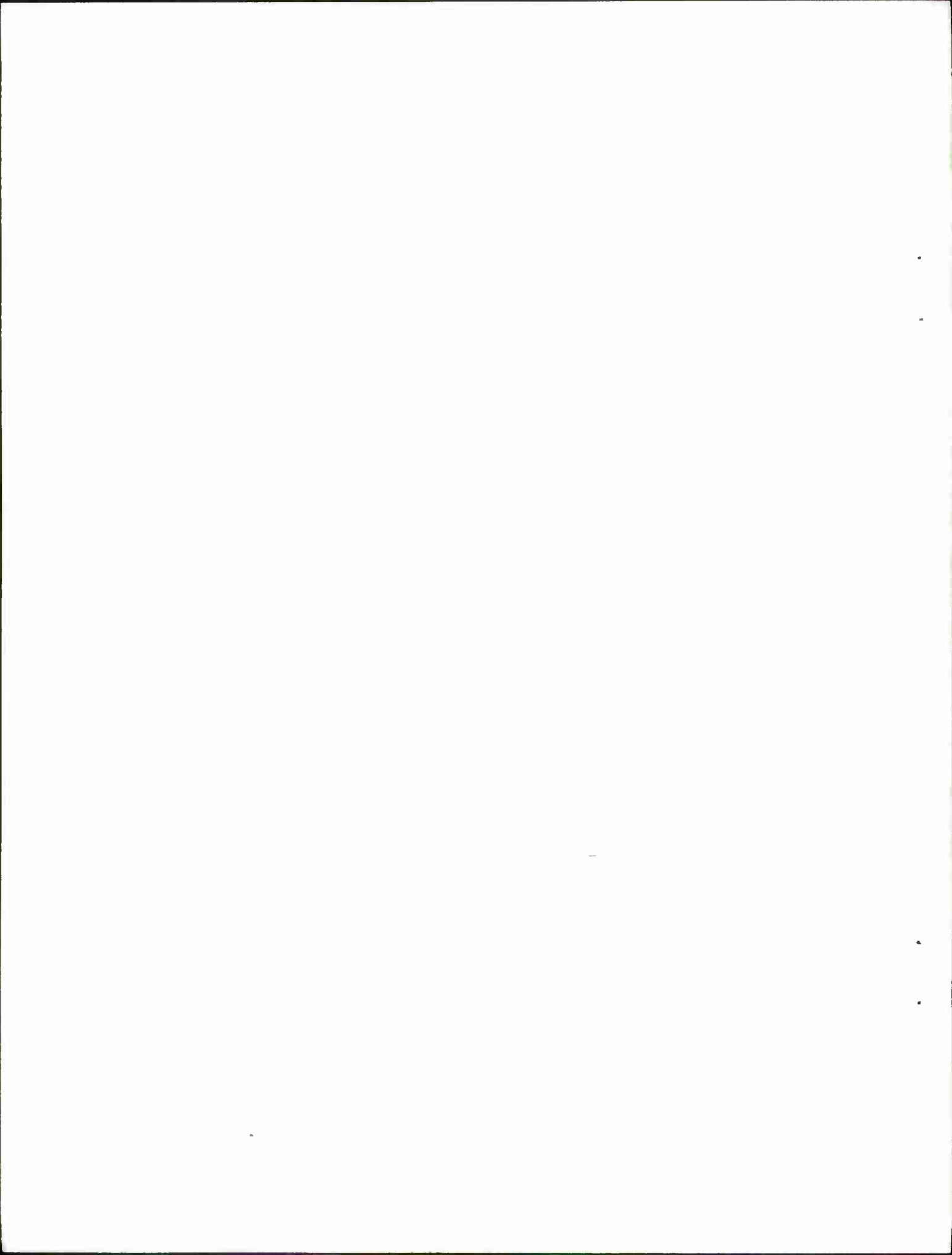

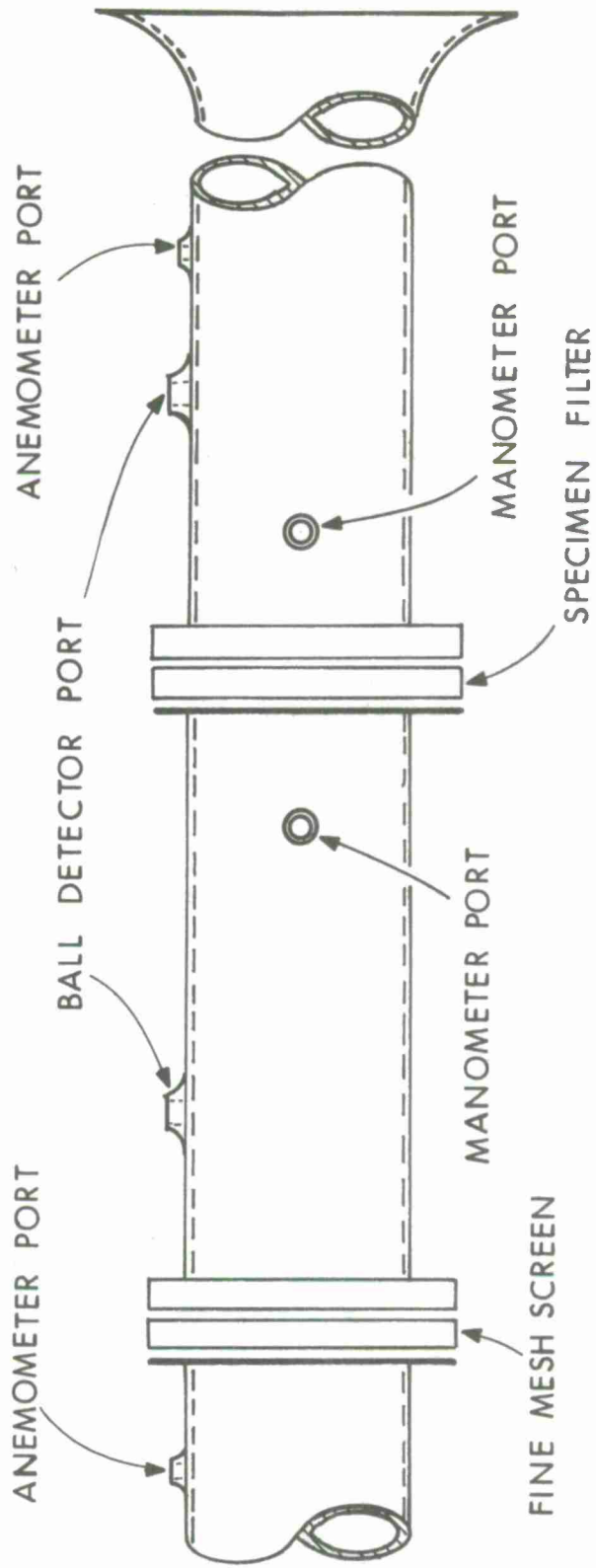

Figure 1. Filter Test Fixture

of three sections fitted with flanges that allow the sections to be bolted together. The filter was mounted between two of the sections in a manner that allowed no air flow around the edges of the filter. A fine mesh screen (111 μm opening) was similarly mounted downstream of the filter to collect fibers that passed through the filter. A variable speed blower attached to the downstream end draws air through the assembly. Two charge transfer detectors are symmetrically mounted, one upstream of the filter and one downstream. A hot wire anemometer monitors the air flow through the filter and a manometer measures the pressure drop across it.

The test fixture blower assembly is operated completely inside the test chamber; it ingests chamber air and exhausts back into the chamber.

2. Measurements. The filters were tested with 3 lengths of fiber and for 3 rates of air flow. Concentration and exposure were determined with the charge transfer ball detector, and fiber length distribution was determined using sticky tape and the fine mesh screen. The following determinations were made:

a. Concentration and Exposure as a Function of Time. Fiber concentration was determined with the charge transfer ball detector. The system consists of the ball, a multi-channel analyzer, and a voltage level discriminator. The electrically charged ball gives up a portion of its charge to fibers that pass within a certain distance of it. The electrical pulses produced by this transfer of charge represent counted fibers and, with proper calibration, fiber concentration.

The multi-channel analyzer is an array of 1024 storage registers in which the fiber counts are stored. The array is divided into two groups, one for each ball, and the counts from the upstream ball and the downstream ball are recorded simultaneously. Each pair of channels sums and stores counts for a fixed interval of time, typically 1 to 5 seconds. The channels are addressed sequentially and incremented with time so that the full array records for the duration of the test. Concentration and exposure as a function of time are derived from this recording.

The ball is connected to the multi-channel analyzer through a voltage level discriminator. The discriminator prevents low level electrical noise pulses from being counted as fibers. It also determines the shortest length fiber that the system will count, since the amplitude of the electrical pulse from the ball is a function of the length of the fiber. Care is taken to shield against noise so that the discriminator may be set low enough to count the shortest fibers expected to be encountered. The discriminator setting is given as an equivalent fiber length for each test.

²John A. Morrissey, William Brannan, and Samuel Thompson, "Calibration of BRL Ball and Sticky Cylinder Detector Systems (U)," *Ballistic Research Laboratory, Technical Report ARBRL-TR-02079, Jun 78, (UNCLASSIFIED).*

(AD #B029204L)

The charge transfer balls are mounted, symmetrically, upstream and downstream of the filter (see Figure 1) and filter performance is determined from the ratio of the two ball measurements. Note that the ball positions are physically and electrically similar and that the counts from the two balls are recorded simultaneously. This assures the same response from both balls and acts to cancel the effects of calibration errors and of variations occurring during the test such as, for example, a change in the air flow rate. The ratio of the two ball measurements possesses greater accuracy than is found in either ball measurement taken separately.

b. Filter Transmission Factor as a Function of Exposure. The filter transmission factor, the ratio of the downstream exposure to the upstream exposure, was derived from the recorded charge transfer ball data. The transmission factor is a measure of the effectiveness of the filter.

c. Fiber Length Distribution. The fiber length distribution was sampled upstream and downstream of the filter. The upstream sampling was done by collecting fibers on sticky tapes at several locations in the test chamber; the downstream sampling by collecting fibers on the fine mesh screen in the test fixture. The fine mesh screen collects virtually 100% of the fibers that pass through the specimen filter. It is made from polyethylene filaments and has a mesh opening of $111 \mu\text{m}$. After the test run, sticky tapes were used to remove the fibers from the fine mesh screen. The tapes, which are 39 mm squares and transparent, were mounted in 35 mm slide holders and projected, magnified 10 times, onto a screen where the fibers were counted for number and measured for length. The amount of fiber breakup through the filter was determined from a comparison of the fiber length distribution upstream and downstream of the filter.

d. Air Flow Rate and Pressure Differential. The velocity of the air flow through the filter was monitored throughout each test with a hot wire anemometer. A manometer monitored the increase in the pressure drop across the filter from the beginning of the test to the end (ΔP).

3. Test and Cleanup Procedures. The fiber disseminator and the 12 muffin fans were operated to produce and maintain a relatively high concentration of carbon fibers in the chamber air. This fiber laden air was drawn through the specimen filter (by the blower attached to the test fixture) until the exposure became approximately 1×10^7 fiber-seconds/ m^3 at the input detector (Ball #1). The duration of the test ranged from 30 to 40 minutes.

A formal cleanup followed each test run. The interior of the test chamber was vacuum cleaned. The filter test fixture was disassembled and vacuum cleaned inside and out. Following the vacuum cleaning the chamber and test fixture were wiped down with a damp sponge. The chamber and test fixture were inspected and, if necessary, the procedure was repeated.

The fine mesh screen was vacuum cleaned, air blown, inspected, and finally pressed against a large sheet of sticky tape. If the tape showed that fibers remained on the fine mesh screen, the procedure was repeated.

B. Specimen Filters - Description, Preparation, and Test Results

1. Fiberglass Furnace Filters.

a. Description. These are 2.54 cm thick adhesive coated fiberglass filters of the type commonly used in household furnaces; the manufacturer is the American Air Filter Company, Inc., Louisville, Kentucky. They bear the designation: Filters, Air Conditioning, Type I, together with the federal stock number - FSN 4130-00-542-4482.

b. Preparation. The adhesive that the manufacturer applies to these filters is principally a water soluble hydrocarbon oil that can lose effectiveness with continuing filter use. For this reason the filters were divided into three groups. The first group was tested as received; the second and third groups were tested after use, i.e., after air had been passed through the filter at a flow rate of 3.6 m/s, for 30 and 60 eight-hour days, respectively. Since the air was somewhat dust laden, these filters were moderately soiled when tested. A separate filter was used for each test.

c. Test Results. Percent fiber transmission was determined with Hercules AS fibers in three lengths - 3.5 mm, 7.5 mm, and 15 mm. For each length of fiber a test run was made at each of three rates of air flow - 0.5 m/s, 2 m/s, and 3.5 m/s.

The results of the 27 tests are summarized in Tables I, II, and III where the percent fiber transmission is presented for each of six levels of input exposure for each test run. The exposure is given in fiber-seconds/m³; the number heading each of the six columns of fiber transmission data is the input exposure divided by 1×10^5 . The tables include the discriminator setting as an equivalent fiber length and ΔP , the increase in the pressure drop across the filter from the beginning to the end of the test run.

TABLE I FILTER TRANSMISSION RESULTS

FILTER: FURNACE (FIBERGLASS, 25mm thick) - NEW

RUN NO.	FIBER LENGTH (mm)	AIR VEL (m/s)	Δ	FIBER TRANSMISSION (%)						DISCRIM CUTOFF (mm)	Δ P (mm of water)	
				INPUT EXPOSURE X 10 ⁻⁵	50	100	50	100	50			
1	3.5	0.5	*	0.4	0.4	0.4	0.5	1.2	0.5	1.2	2.0	0
2	3.5	2.0	*	*	0.2	0.1	0.2	0.3	0.2	0.3	2.0	0.5
3	3.5	3.5	*	1.4	1.5	1.8	3.5	2.4	3.5	2.4	2.0	2.3
4	7.5	0.5	*	*	*	*	*	0.4	*	0.4	2.5	0
5	7.5	2.0	*	*	*	0.2	0.1	0.1	0.2	0.1	2.5	0.8
6	7.5	3.5	2.0	0.4	1.3	2.0	3.4	3.0	3.4	3.0	2.5	6.0
7	15	0.5	*	*	*	0.1	*	*	*	*	4.0	0
8	15	2.0	1.0	0.2	0.1	0.1	*	*	*	*	4.0	1.8
9	15	3.5	*	0.6	2.0	1.9	2.1	2.6	2.1	2.6	4.0	1.8

FIBER - HERCULES TYPE AS

* LESS THAN 0.1% TRANSMISSION

TABLE II FILTER TRANSMISSION RESULTS

FILTER: FURNACE (FIBERGLASS, 25mm thick) - 30 Days

RUN NO.	FIBER LENGTH (mm)	AIR VEL (m/s)	I	FIBER TRANSMISSION (%)			DISCRIM CUTOFF (mm)	ΔP (mm of water)
				INPUT EXPOSURE X 10^{-5}	fiber-s/m ³	50 100		
1	3.5	0.5	*	0.4	0.8	1.3	2.0	0
2	3.5	2.0	*	2.8	2.5	4.1	2.0	0.8
3	3.5	3.5	23.0	9.8	6.6	7.3	2.0	1.8
4	7.5	0.5	*	0.2	0.1	0.4	2.5	0
5	7.5	2.0	1.4	0.2	0.1	0.7	2.5	0.3
6	7.5	3.5	*	1.3	1.1	1.1	2.5	2.0
7	15	0.5	*	*	*	*	4.0	0
8	15	2.0	*	0.8	0.4	0.3	4.0	0.8
9	15	3.5	1.1	1.9	1.9	2.0	4.0	1.8

FIBER - HERCULES TYPE AS

* LESS THAN 0.1% TRANSMISSION

TABLE III FILTER TRANSMISSION RESULTS

FILTER: FURNACE (FIBERGLASS, 25mm thick) - 60 Days

RUN NO.	FIBER LENGTH (mm)	AIR VEL (m/s)	FIBER TRANSMISSION (%)							DISCRIM CUTOFF (mm)	ΔP (mm of water)
			INPUT EXPOSURE X 10^{-5} fiber-s/m ³	1	5	10	20	50	100		
1	3.5	0.5	*	*	*	*	*	*	0.4	2.0	0.3
2	3.5	2.0	1.9	3.3	2.9	2.6	2.8	2.3	2.3	2.0	0.5
3.	3.5	3.5	22.2	16.4	18.7	14.5	12.8	12.8	12.8	2.0	1.3
4	7.5	0.5	*	*	*	*	*	*	*	2.5	1.3
5	7.5	2.0	*	*	1.7	1.7	1.5	1.3	1.3	2.5	0
6	7.5	3.5	6.4	6.7	6.1	6.7	9.0	11.1	11.1	2.5	1.3
7	15	0.5	*	*	*	*	*	*	*	4.0	0
8	15	2.0	*	*	0.4	0.3	0.2	0.1	0.1	4.0	0.3
9	15	3.5	5.6	7.8	5.8	5.4	4.0	3.6	3.6	4.0	1.8

FIBER -HERCULES TYPE AS

* LESS THAN 0.1% TRANSMISSION

For the new furnace filters, tested at a flow rate of 2 m/s or less, the fiber transmission was 1.2% as a maximum and was generally less than 0.4%. At 3.5 m/s, the maximum fiber transmission was 3.5%. The furnace filters that had 30 and 60 days use before testing showed generally greater fiber transmission. The greater transmission occurred mainly at the highest (3.5 m/s) air flow rate and was significantly greater for the shortest (3.5 mm) fiber.

The results are presented graphically for a single run. Figures 2 and 3 show concentration and exposure (the smooth curve) as a function of time upstream and downstream of the filter. A representative plot of fiber length distribution upstream and downstream of the filter is presented in Figure 4. As can be seen, there was very little fiber breakup through these filters.

2. Pleated Panel Filter.

a. Description. The Taffco Pleated Panel Filter employs a thin (3 mm) but dense filter medium arranged in an accordion fold to increase the surface area. With the medium folded, the nominal thickness of the tested filters is 5 cm. Two similar filters having efficiency ratings of 40% and 60% were tested. The efficiency rating refers to the weight fraction of a standard synthetic dust stopped by the filter. The manufacturer is Tidewater Air Filter Fabrication, Inc.

b. Preparation. To ensure an airtight seal at the edges, the filter medium was removed from its frame, the pleats were removed, and circular pieces were cut to fit the test fixture. A separate filter was used for each test.

c. Test Results. These filters were tested with Hercules AS fibers of a single length, 3.5 mm, at 3 rates of air flow. The percent fiber transmission for these filters was very low. The number of fibers penetrating the filter ranged between 9 and 390 depending on the air velocity and filter medium efficiency (40% or 60%). Accordingly, the ball detector was not used to determine the downstream exposure. Instead, a visual count was made of all of the fibers collected on the fine mesh screen and from this we calculated the downstream exposure and the percent transmission. The precision of these experiments does not justify expressing the percent transmission to 3 decimal places. However, the relative ordering of these small numbers is possibly valid information. The test results are given in Table IV.

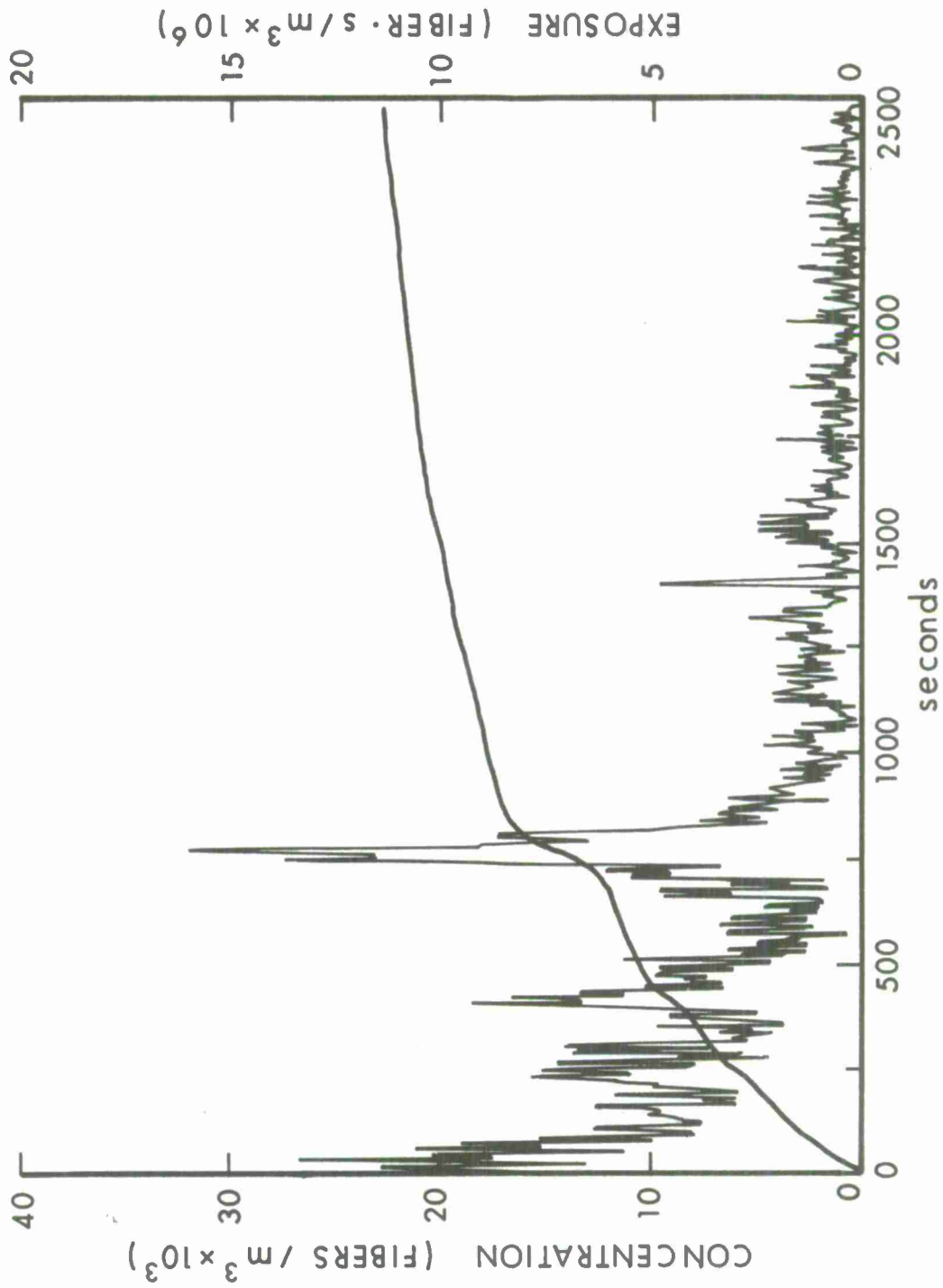

Figure 2. Typical Upstream Concentration and Exposure Plot for Furnace Filter Tests

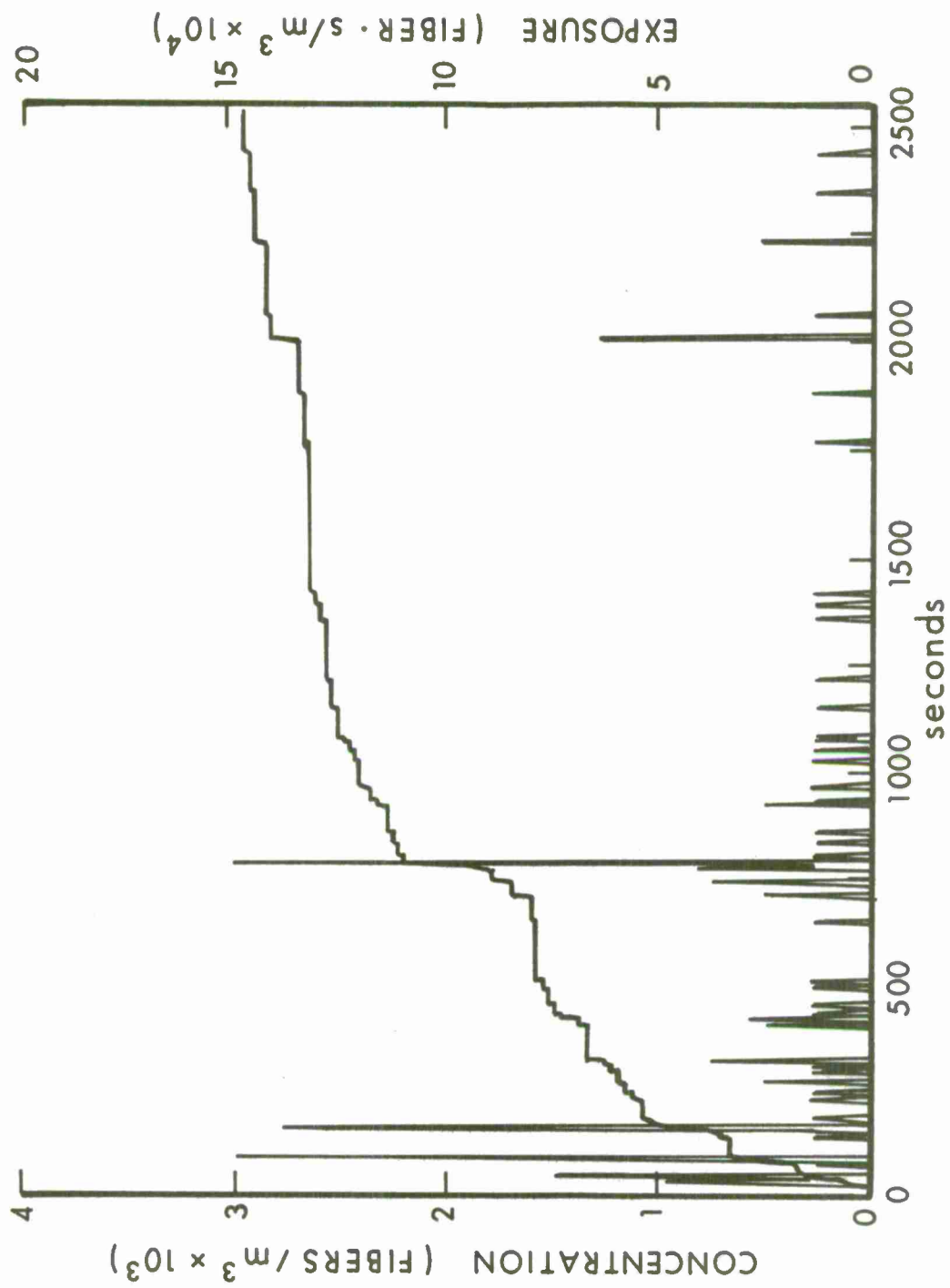

Figure 3. Typical Downstream Concentration and Exposure Plot for Furnace Filter Tests

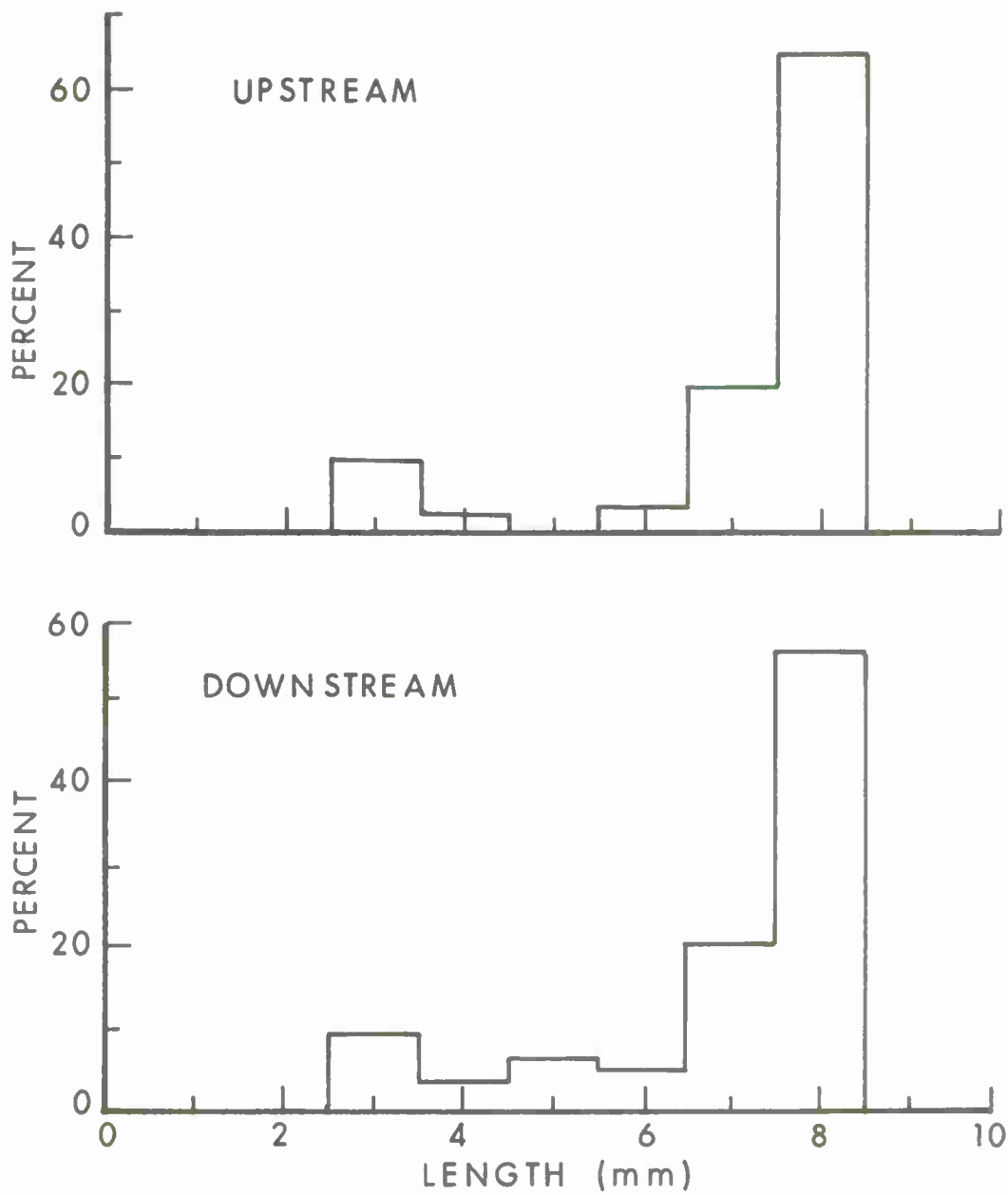

Figure 4. Typical Length Distributions for Furnace Filter Tests

TABLE IV. FILTER TRANSMISSION RESULTS

FILTER: PLEATED PANEL - 40% AND 60% EFFICIENCY

INPUT EXPOSURE - 1.3×10^7 fiber-s/m³

RUN NO.	AIR VEL (m/s)	TOTAL DOWNSTREAM FIBER COUNT	FIBER TRANSMISSION (%)	ΔP (mm of water)
<u>40 PERCENT EFFICIENCY</u>				
1	0.5	29	.024	0.3
2	1.5	120	.031	0.5
3	3.0	390	.058	1.0
<u>60 PERCENT EFFICIENCY</u>				
4	0.5	9	.006	0.3
5	1.5	18	.005	0.5
6	3.0	107	.015	1.8

FIBER - HERCULES TYPE AS, 3.5 mm LONG

3. Window Screen.

a. Description. The specimen filter is copper window screen. The screen is made from 0.3 mm diameter wire and has a rectangular opening between wires of 1.2 mm by 1.6 mm.

b. Preparation. A circular piece of screen was cut for mounting in the filter test fixture. It was clamped between gaskets that allowed no air flow around the edges. Since one piece of screen was used for all the tests a thorough cleaning and a careful inspection followed each test run.

c. Test Results. Hercules AS fibers in three lengths - 3.5 mm, 7.5 mm, and 15 mm were used for the window screen tests. For each length of fiber a test run was made at each of three rates of air flow 0.5 m/s, 2.0 m/s, and 3.6 m/s.

The window screen is an effective filter for carbon fibers at an air flow rate of 0.5 m/s, but the effectiveness decreases with increasing air flow rate and decreasing fiber length. The results of the nine tests are summarized in Table V. The filter transmission factor is presented for each of six levels of exposure for each test run. The table includes the discriminator setting and ΔP , the increase in the pressure drop across the filter from the beginning to the end of the test run. The results are presented graphically for a single run in Figures 5, 6, and 7. Figures 5 and 6 show the concentration and exposure as a function of time, upstream and downstream of the filter.

There was little fiber breakup through the window screen. This is illustrated by the graphs of fiber length distribution, upstream and downstream of the window screen, presented in Figure 7.

4. Room Air Conditioner Filters.

a. Description. Two similar adhesive coated fiberglass filters, 10 mm and 12 mm thick respectively, were tested. Intended for use in room air conditioning units, this type of filter medium is supplied in 0.4 m x 15 m rolls and is typically about 12 mm thick; the medium is cut to fit the application. Although the two filters were similar and were made by the same manufacturer, the 12 mm thick medium was coarser and less uniform than the 10 mm medium. The federal stock number for the 10 mm thick medium is 4130-00-X05-0029; for the 12 mm thick medium it is 4130-00-906-2246. Both are a product of DRICO INDUSTRIAL CORPORATION.

b. Preparation. The filters were tested as received using a separate piece of the medium for each test.

c. Test Results. These filters were generally as effective as the furnace filters. However, the transmission was higher at low levels of exposure and higher for the 3.5 mm long fiber through the 12 mm

TABLE V. FILTER TRANSMISSION RESULTS

FILTER: WINDOW SCREEN

RUN NO.	FIBER LENGTH (mm)	AIR VEL (m/s)	FIBER TRANSMISSION (%)						DISCRIM CUTOFF (mm)	ΔP (mm of water)	
			INPUT EXPOSURE X 10^{-5} fiber-s/m ³	1	5	10	20	50			100
1	7.5	2.0	4.0	5.8	4.8	4.8	4.8	3.8	3.6	3.5	0.6
2	7.5	0.5	2.0	1.6	1.2	1.2	1.2	1.2	1.2	3.5	0.4
3	7.5	3.6	21.0	11.4	10.1	9.6	6.8	4.3	3.5	3.5	3.2
4	3.5	2.0	57.0	42.4	36.8	31.0	25.6	16.4	2.0	2.0	0.4
5	3.5	0.5	8.0	4.4	3.3	3.4	3.0	2.7	2.0	2.0	0.3
6	3.5	3.6	44.0	49.0	39.4	51.4	20.1	15.9	2.0	2.0	3.1
7	15	3.6	16.0	9.6	10.0	8.5	6.4	4.5	4.0	4.0	2.8
8	15	0.5	2.0	0.4	0.6	0.3	0.1	0.1	4.0	4.0	0.3
9	15	2.0	2.0	1.8	2.8	3.9	4.4	3.7	4.0	4.0	0.4

FIBER - HERCULES TYPE AS

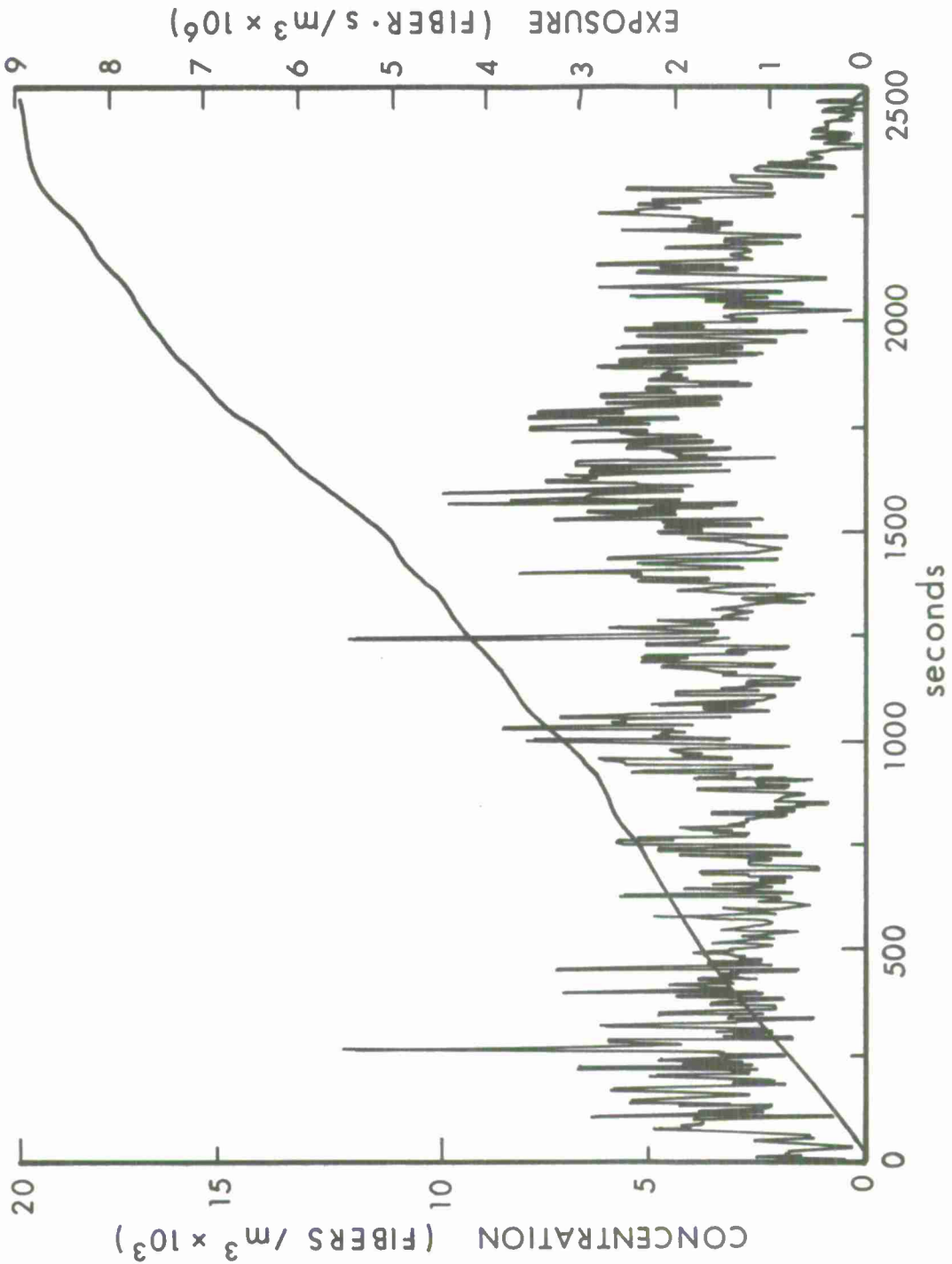

Figure 5. Typical Upstream Concentration and Exposure Plot for Window Screen Tests

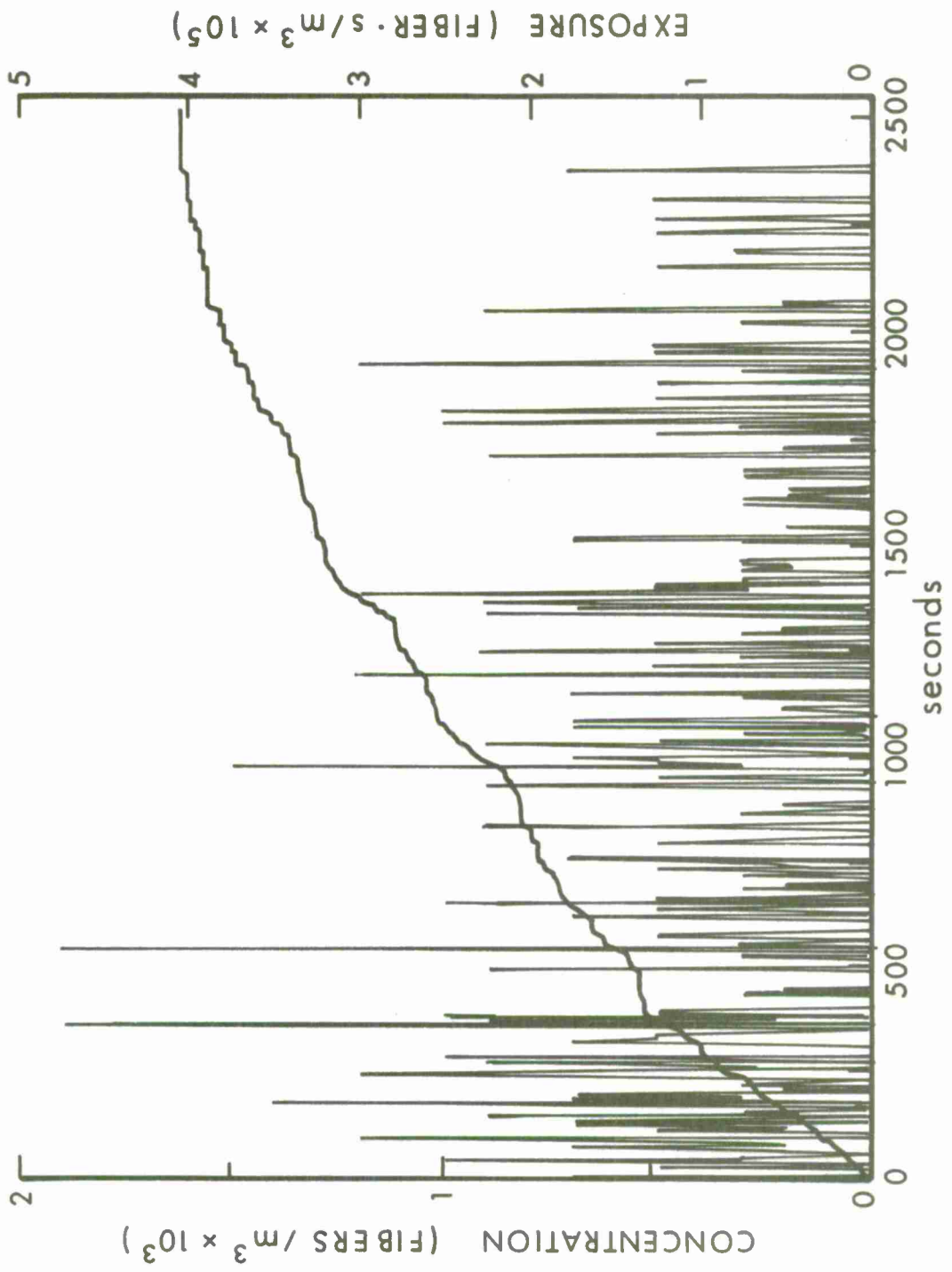

Figure 6. Typical Downstream Concentration and Exposure Plot for Window Screen Tests

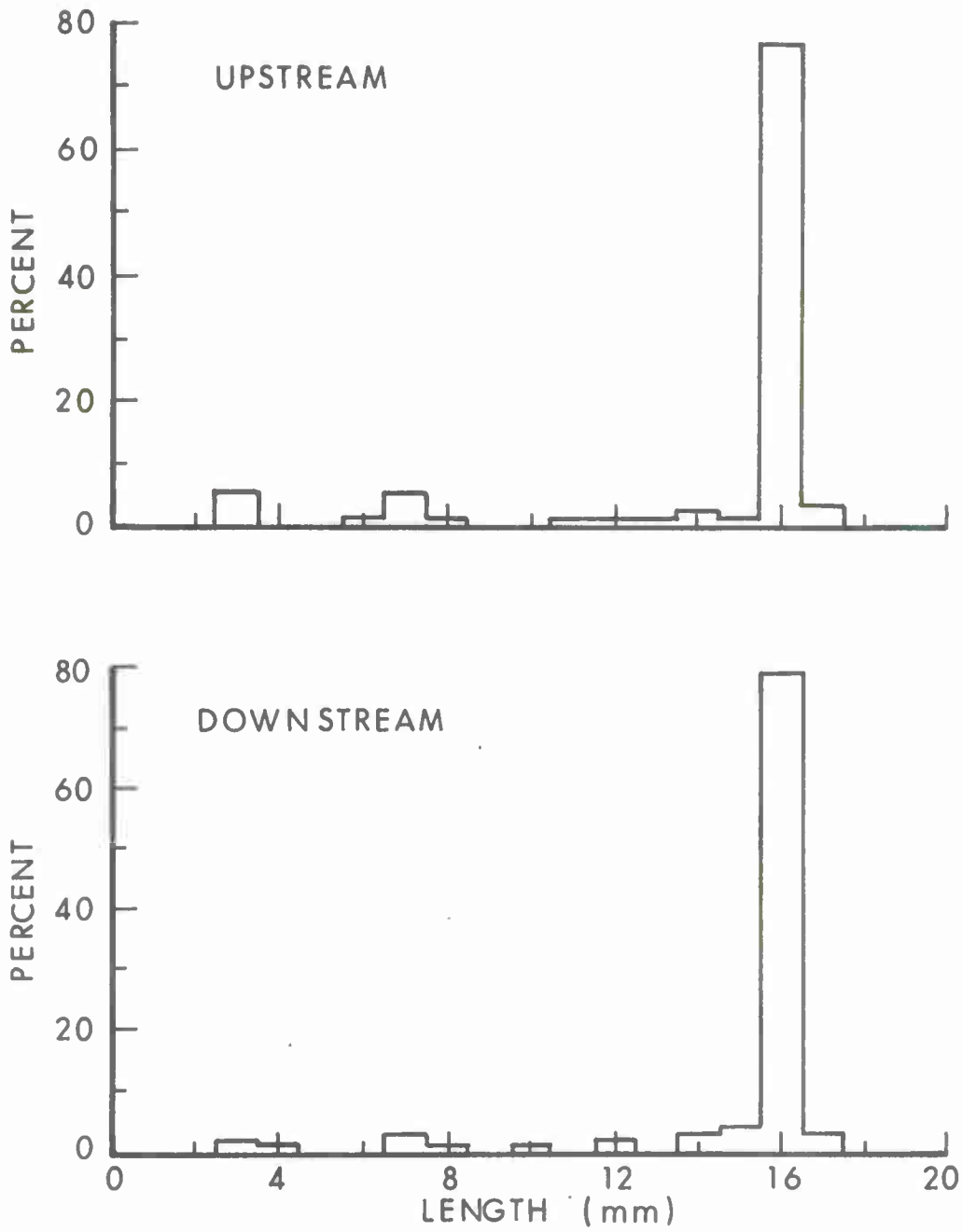

Figure 7. Typical Length Distributions for Window Screen Tests

thick filter. Here a value of 8.1% was recorded for a flow rate of 3.6 m/s. The results of the 18 tests are given in Tables VI and VII. The results are presented graphically for a single test run. Figures 8 and 9 show concentration and exposure as a function of time upstream and downstream of the filter. Figure 10 is a representative plot of fiber length distribution upstream and downstream of the filter and, as can be seen, there was little fiber breakup through these filters.

III. AIR CONDITIONING DUCT TESTS

A. Description of Tests.

The object of the duct tests was to determine the possible breakup of carbon fibers through air conditioning duct work. The test duct consists of two 1-meter lengths of 15 cm diameter duct joined by a standard 90 degree elbow. A blower connected to one end draws air through the duct at a velocity that was measured and held at 6 m/s. Six cylindrical sticky tape detectors were mounted within the duct, three before and three after the elbow, arranged as shown in Figure 11. The tests were performed in the ECOM chamber with Hercules AS fibers in two nominal lengths, 7 mm and 13 mm. The duct-blower assembly ingests chamber air and exhausts back into the chamber. Fibers were introduced into the chamber and the concentration was held relatively constant until the exposure in the chamber became approximately 1×10^6 fiber-seconds/m³. After the test run, the sticky cylinders were cut, mounted flat in 35 mm slide holders, and projected magnified 10 times onto a screen where the fibers were counted and measured for length. Fiber breakup was assessed by comparing the mean fiber length before and after the elbow.

B. Results.

The results are presented in Table VIII. The six runs show that the mean fiber length was the same before and after the elbow indicating that the fibers traverse the elbow without breaking.

IV. GENERIC CABINET TESTS

A. Description of the Tests.

The cabinet in which a piece of electronic equipment is housed may affect the exposure of the enclosed electronics to carbon fibers.

TABLE VI FILTER TRANSMISSION RESULTS

FILTER: ROOM AIR CONDITIONER (FIBERGLASS, 12 mm thick)

FIBER TRANSMISSION (%)

RUN NO.	FIBER LENGTH (mm)	AIR VEL (m/s)	1	INPUT EXPOSURE X 10 ⁻⁵ fiber-s/m ³			DISCRIM CUTOFF (mm)	Δ P (mm of water)		
				5	10	20			50	100
1	3.5	0.5	*	0.4	0.4	5.2	2.8	2.0	2.0	0.1
2	3.5	2.0	*	1.4	1.6	2.6	2.4	3.0	2.0	0.4
3	3.5	3.6	3.0	5.4	5.9	7.1	6.9	8.1	2.0	0.4
4	7.5	0.5	7.0	1.4	0.7	0.4	0.1	0.1	3.5	0
5	7.5	2.0	*	0.2	0.3	0.7	1.3	1.6	3.5	0.6
6	7.5	3.6	*	2.0	1.8	1.8	1.5	1.6	3.5	1.3
7	15	0.5	*	*	*	*	*	*	4.0	0
8	15	2.0	*	*	*	0.1	0.4	0.3	4.0	0
9	15	3.6	1.0	3.0	2.8	3.9	4.2	4.1	4.0	0

FIBER - HERCULES TYPE AS

* LESS THAN 0.1% TRANSMISSION

TABLE VII FILTER TRANSMISSION RESULTS

FILTER: ROOM AIR CONDITIONER (FIBERGLASS, 10 mm thick)

RUN NO.	FIBER LENGTH (mm)	AIR VEL (m/s)	FIBER TRANSMISSION (%)					DISCRIM CUTOFF (mm)	ΔP (mm of water)	
			1	5	10	10^{-5}	10^{-5}			
						50	100			
1	3.5	0.5	2.0	0.4	0.2	0.1	0.1	0.1	2.0	0.1
2	3.5	2.0	*	1.6	1.9	1.5	1.0	1.1	2.0	0.4
3	3.5	3.6	5.0	2.8	2.5	2.7	3.2	3.6	2.0	1.3
4	7.5	0.5	*	*	*	*	0.2	0.1	3.5	0
5	7.5	2.0	*	0.6	0.3	0.2	0.2	0.2	3.5	0.3
6	7.5	3.6	*	0.4	1.0	0.9	1.0	1.1	3.5	1.0
7	15	0.5	*	0.4	0.2	0.1	0.1	*	4.0	0
8	15	2.0	*	*	*	*	0.2	0.2	4.0	0
9	15	3.6	1.0	0.3	0.3	0.3	1.9	3.6	4.0	1.0

FIBER - HERCULES TYPE AS

* LESS THAN 0.1% TRANSMISSION

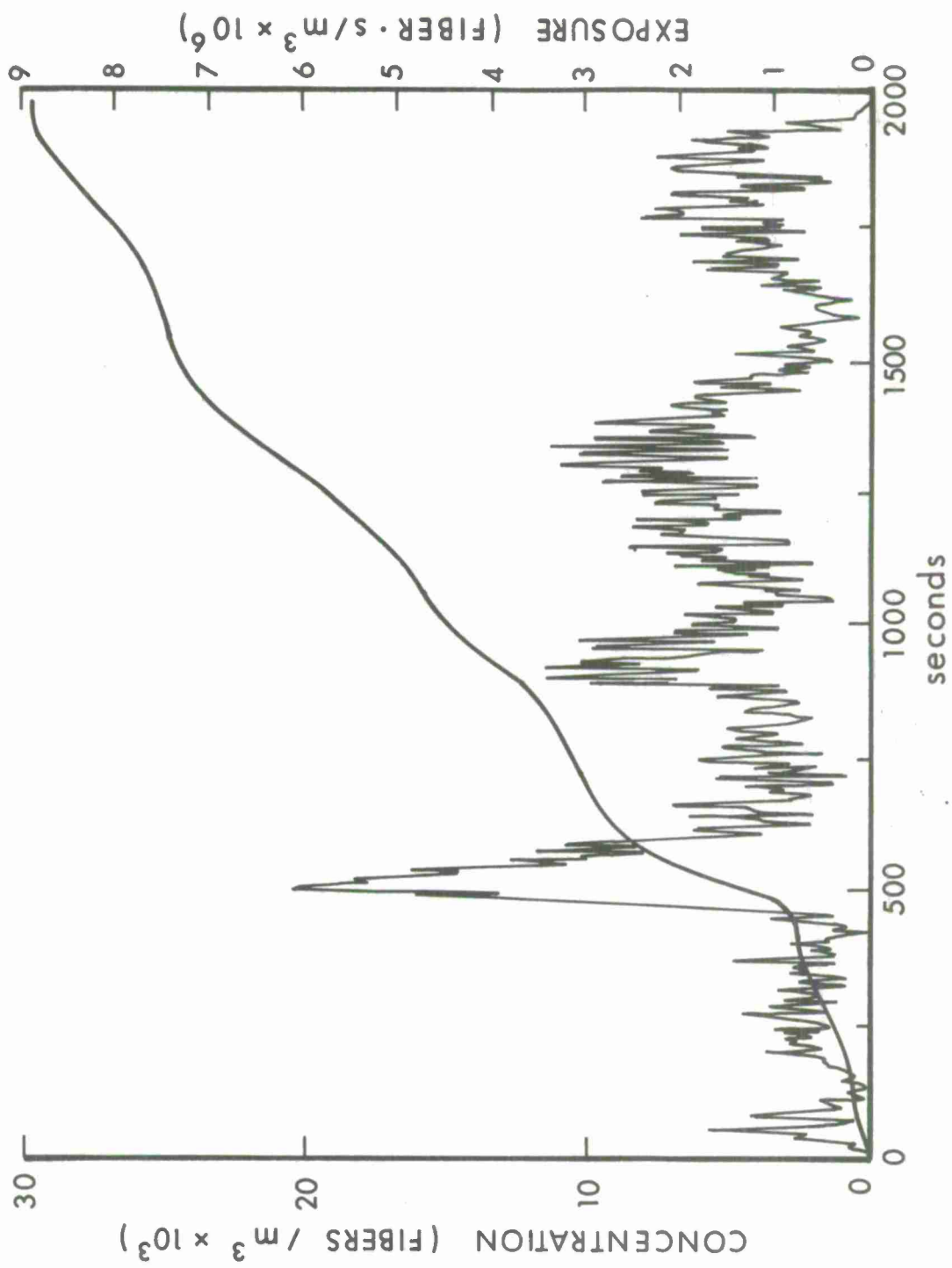

Figure 8. Typical Upstream Concentration and Exposure Plot for Air Conditioner Filter

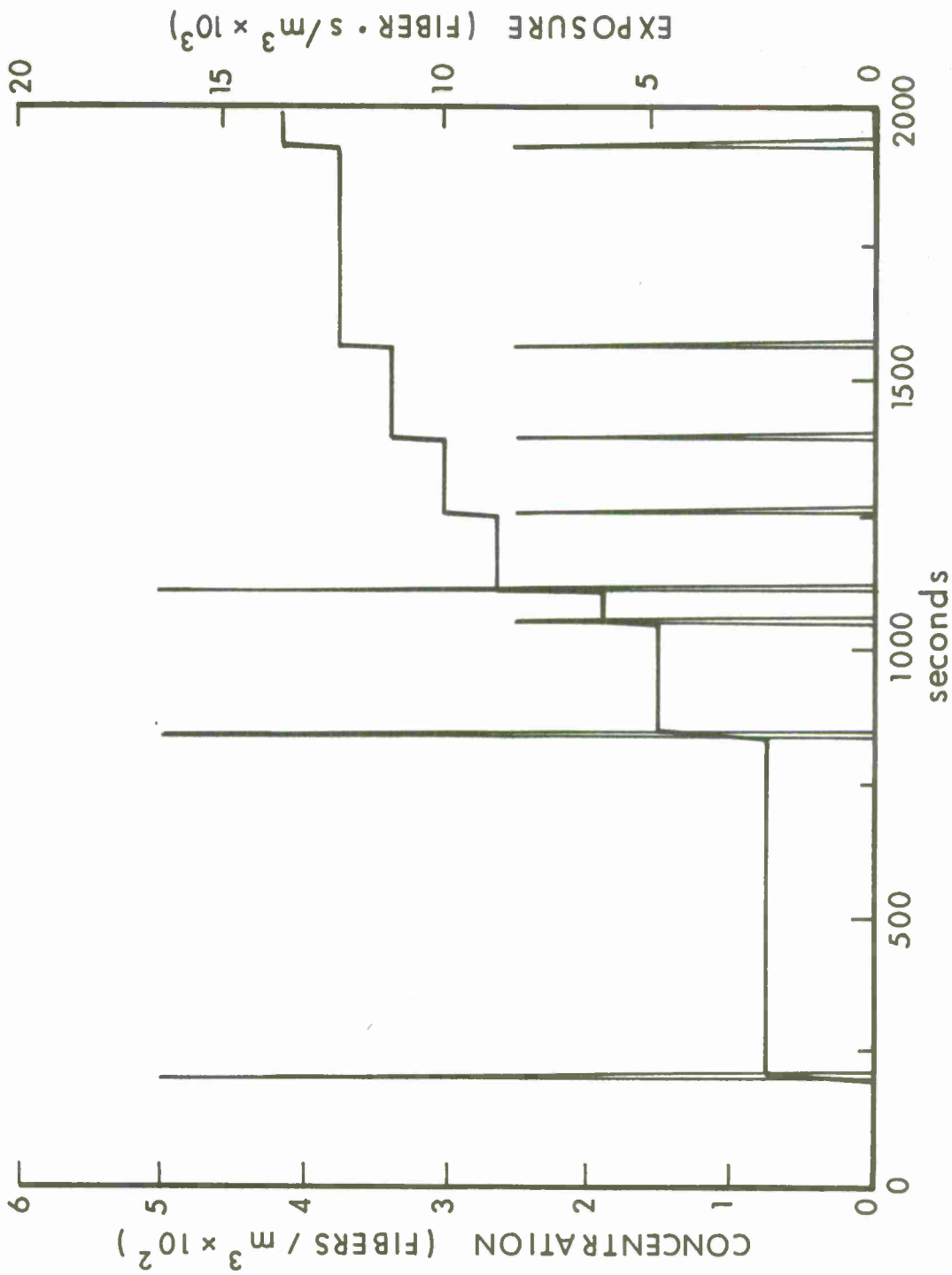

Figure 9. Typical Downstream Concentration and Exposure Plot for Air Conditioner Filter Tests

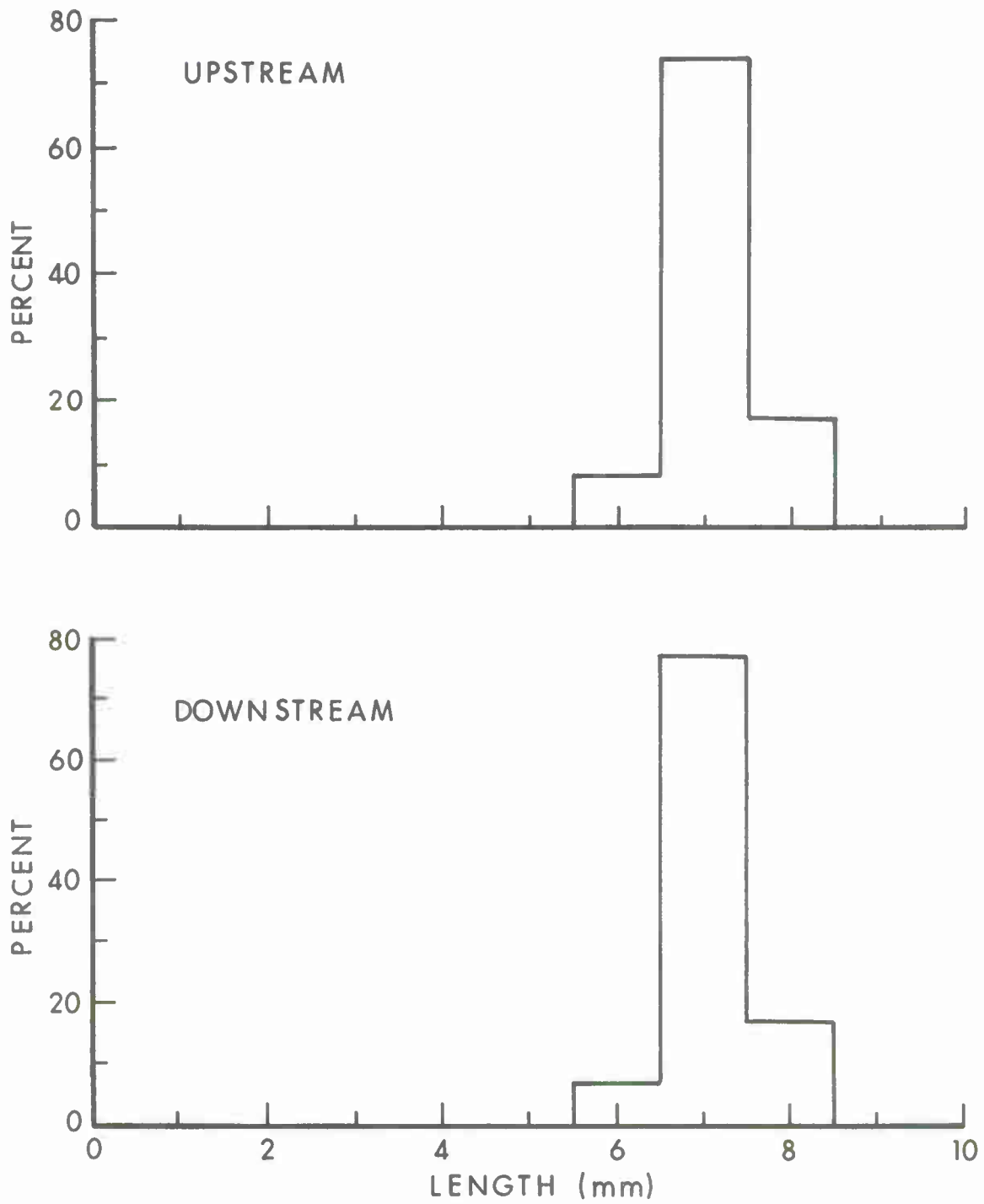

Figure 10. Typical Length Distributions for Air Conditioner Filter Tests

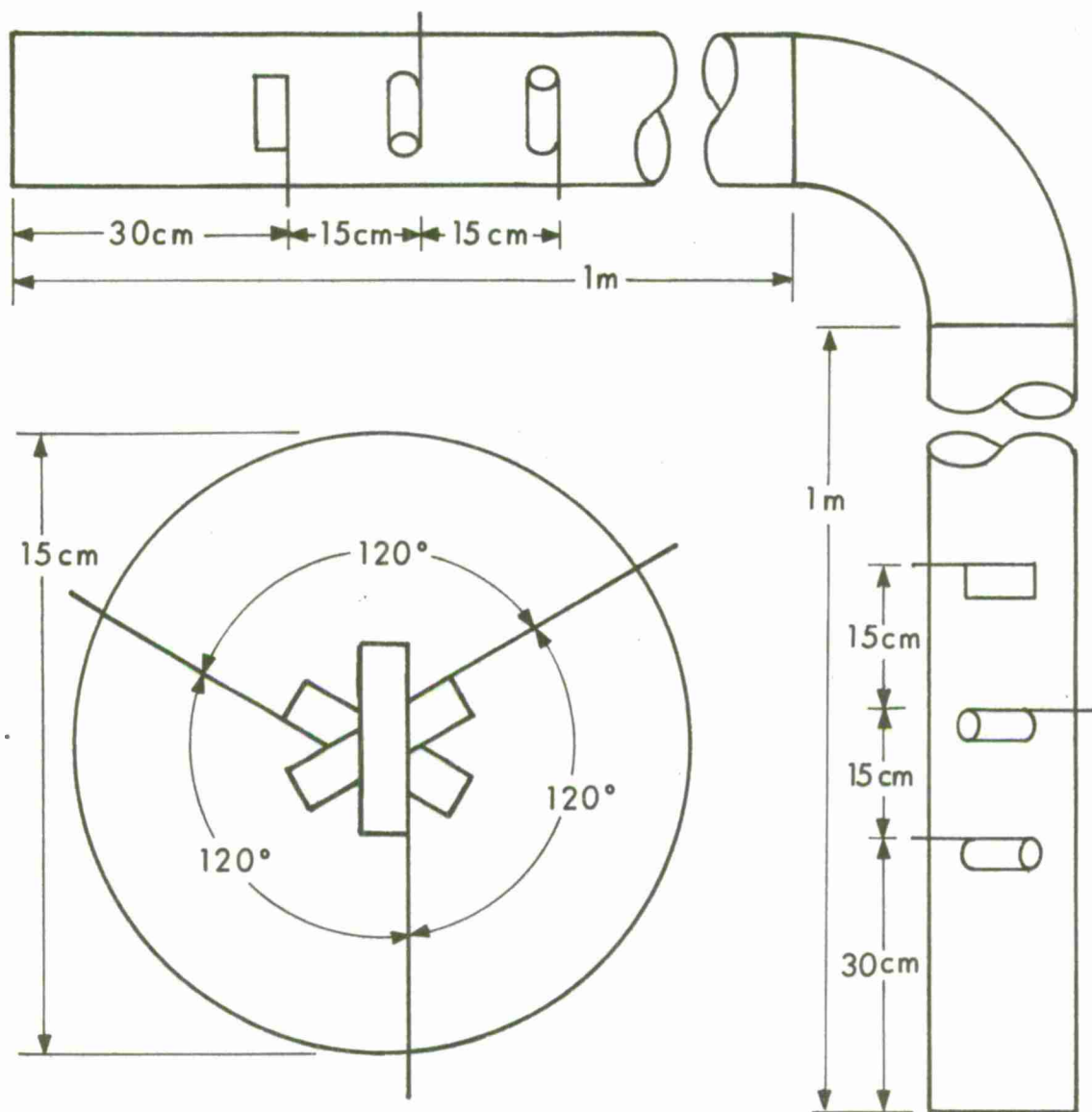

Figure 11. Experimental Apparatus for Fiber Breakup Tests

TABLE VIII. DUCT TESTS LENGTH DATA SUMMARY

RUN No.	MEAN FIBER LENGTH (mm)	
	BEFORE ELBOW	AFTER ELBOW
1	7.0	7.0
2	6.7	7.1
3	6.9	6.9
4	12.5	12.0
5	14.0	13.5
6	12.1	12.5

AIR VELOCITY - 6m/s

FIBER -HERCULES TYPE AS

The generic cabinet tests were designed to give numbers for the transfer of carbon fibers from the outside to the inside of the cabinet (the transfer function) for both convective and fan-forced air flow. The dimensions of the cabinet were typical of large rack mounted or counter-top electronic equipment 48 cm x 48 cm at the base and 33 cm high. Feet on the bottom of the cabinet raised the cabinet 2.5 cm above the table on which it was tested. All panels, top, bottom, and side, were replaceable so that tests for both convective air flow and fan-forced air flow could be made with the same cabinet. No air filters were used.

For the convective air flow tests, the top and bottom panels were perforated with either slots or holes and the open areas top and bottom were made the same. This was 90 cm² for the holes and 400 cm² for the slots. The holes were 6.4 mm in diameter; the slots were 3.2 mm wide. The interior of the cabinet was heated by two electrical heating elements, each of which has a surface area of 300 cm². The heat input, in watts, is given for each test in Tables IX and X.

For the fan-forced air flow tests, an 11.4 cm diameter muffin fan delivering 0.05 m³/s and blowing into the cabinet was used; the heater was not used. Tests were made with the fan in two locations, 1) at the center of the bottom panel and 2) on one side near the bottom and centered on the side. Two of the side panels had slotted openings 3.2 mm wide in the upper one-third of the panel providing 219 cm² open area for the leaving air.

The cabinet tests were made in the ECOM chamber. Fibers were introduced into the chamber until the exposure outside the cabinet became about 1×10^7 fiber-seconds/m³. This was determined with two charge transfer ball detectors mounted at opposite ends of the table that supported the cabinet. The height of the table was such that the cabinet and the ball detectors were positioned halfway between the ceiling and floor of the chamber. A third ball detector inside the cabinet determined the inside exposure, and the ratio of the inside to the outside exposure is the transfer function. Deposition was determined with 39 mm square sticky tapes placed in four locations on the bottom of the cabinet.

B. Results.

The results of the convective air flow cabinet tests are given in Tables IX and X. For the cabinet with the holes, the range of values for the transfer function is from 0.1% to 9%; for the cabinet with the slots the range is from 1% to 14%. The larger values for the cabinet with the slots is consistent with the 4.4 times greater open area of the slots. For the cabinet with the holes the transfer function decreases markedly with an increase in the rate of heating, indicating that the heated air exits the holes with sufficient velocity to reduce the entry of falling fibers.

TABLE IX
 TRANSFER FUNCTION - GENERIC CABINET
 CONVECTIVE AIR FLOW
 HOLES IN TOP AND BOTTOM PANELS

RUN NO.	FIBER LENGTH (mm)	HEATER (WATTS)	EXPOSURE x 10 ⁻⁵ fiber-s/m ³		TRANSFER FUNCTION (%)	DEPOSITION X 10 ⁻³ f/m ²
			OUTSIDE	INSIDE		
1	3.5	0	180	16.0	9.0	45
2	3.5	0	190	14.0	7.4	34
3	3.5	100	200	1.2	6.0	28
4	3.5	100	150	1.9	1.3	55
5	3.5	250	270	1.4	0.5	84
6	3.5	250	180	2.0	1.1	65
7	7.5	0	120	3.1	2.6	20
8	7.5	0	140	4.7	3.4	35
9	7.5	100	140	0.2	0.1	16
10	7.5	100	130	3.9	3.0	19
11	7.5	250	130	0.2	0.3	15
12	7.5	250	130	0.3	0.3	10
13	10	0	60	0.5	0.8	14
14	10	100	88	0.3	0.4	16
15	10	250	50	0.1	0.2	9

FIBER - HERCULES TYPE HMS

TABLE X
 TRANSFER FUNCTION - GENERIC CABINET
 CONVECTIVE AIR FLOW
 SLOTS IN TOP AND BOTTOM PANELS

RUN NO.	FIBER LENGTH (mm)	HEATER (WATTS)	EXPOSURE $\times 10^{-5}$ fiber-s/m ³		TRANSFER FUNCTION (%)	DEPOSITION $\times 10^{-3}$ f/m ²
			OUTSIDE	INSIDE		
1	3.5	0	220	24.0	11.0	88
2	3.5	0	190	20.0	11.0	88
3	3.5	100	190	16.0	9.0	84
4	3.5	100	230	25.0	11.0	85
5	3.5	250	190	26.0	14.0	78
6	3.5	250	190	22.0	12.0	72
7	7.5	0	170	9.0	5.0	24
8	7.5	0	140	7.4	5.0	30
9	7.5	100	240	9.0	4.0	21
10	7.5	100	190	7.3	4.0	31
11	7.5	250	110	7.8	6.9	33
12	7.5	250	190	9.9	5.2	30
13	10	0	110	2.1	2.0	74
14	10	100	110	2.2	2.0	35
15	10	250	110	1.4	1.0	15

FIBER - HERCULES TYPE HMS

The results for the fan-forced air flow cabinet tests are given in Table XI. With fan-forced air flow the transfer function was virtually 100%.

V. SUMMARY

Air filters, even coarse ones such as window screen, greatly reduce the transmission of carbon fibers. In general, the transmission of fibers through an air filter increases with increasing air flow rate and with decreasing fiber length; it decreases with increasing exposure. The screen transmitted only a few percent of the incident fibers when the air flow rate was 0.5 m/s, and was almost as effective at higher air flow rates when the fibers were 7.5 mm or longer. But at 3.6 m/s, the transmission of the 3.5 mm fibers was 16% at the final exposure level (1×10^7 fiber-s/m³), and was much higher at lower levels of exposure. The 25 mm thick fiberglass furnace filters were effective at the 3.6 m/s air flow rate; the transmission of fibers through the new filters was generally less than 3%, and much less for lower rates of air flow. Fiber transmission was generally higher through the filters that were used before testing. The 10 mm and the 12 mm thick fiberglass filters were nearly as effective as the furnace filters. The transmission of fibers through the pleated panel filters was very low, less than 0.1%, even at the highest flow rate. None of the filters tested caused breaking of the fibers.

The air conditioning duct tests showed that carbon fibers will traverse a 90 degree elbow turn at 6 m/s without breaking. The generic cabinet tests showed that with fan forced cooling, and no air filter, the carbon fiber exposure inside the cabinet will be the same as outside. However, with convective air flow, the inside exposure will be much less; it ranged from a fraction of a percent to 14% for these experiments.

TABLE XI
TRANSFER FUNCTION - GENERIC CABINET
FAN FORCED AIRFLOW

RUN NO.	FIBER LENGTH (mm)	FAN LOCATION	EXPOSURE x 10 ⁻⁵ fiber-s/m ³		TRANSFER FUNCTION (%)	DEPOSITION X 10 ⁻⁵ f/m ²
			OUTSIDE	INSIDE		
1	3.5	SIDE	130	94	72	3.0
2	3.5	SIDE	130	108	83	3.4
3	3.5	BOTTOM	130	143	110	4.8
4	3.5	BOTTOM	130	123	95	4.6
5	7.5	SIDE	120	104	87	3.7
6	7.5	SIDE	110	94	85	3.8
7	7.5	BOTTOM	120	122	102	4.5
8	7.5	BOTTOM	120	118	98	4.6
9	10	SIDE	120	102	85	3.9
10	10	BOTTOM	120	106	88	4.0

FIBER - HERCULES TYPE HMS

ACKNOWLEDGEMENTS

The authors would like to express their appreciation to Neil W. Wolfe and William I. Brannan for their assistance during the operation of the experiments and their aid in compiling the data. They would also like to express their gratitude to Mrs. Judith Hamilton for her patience and dedication during the typing and assembly of this report.

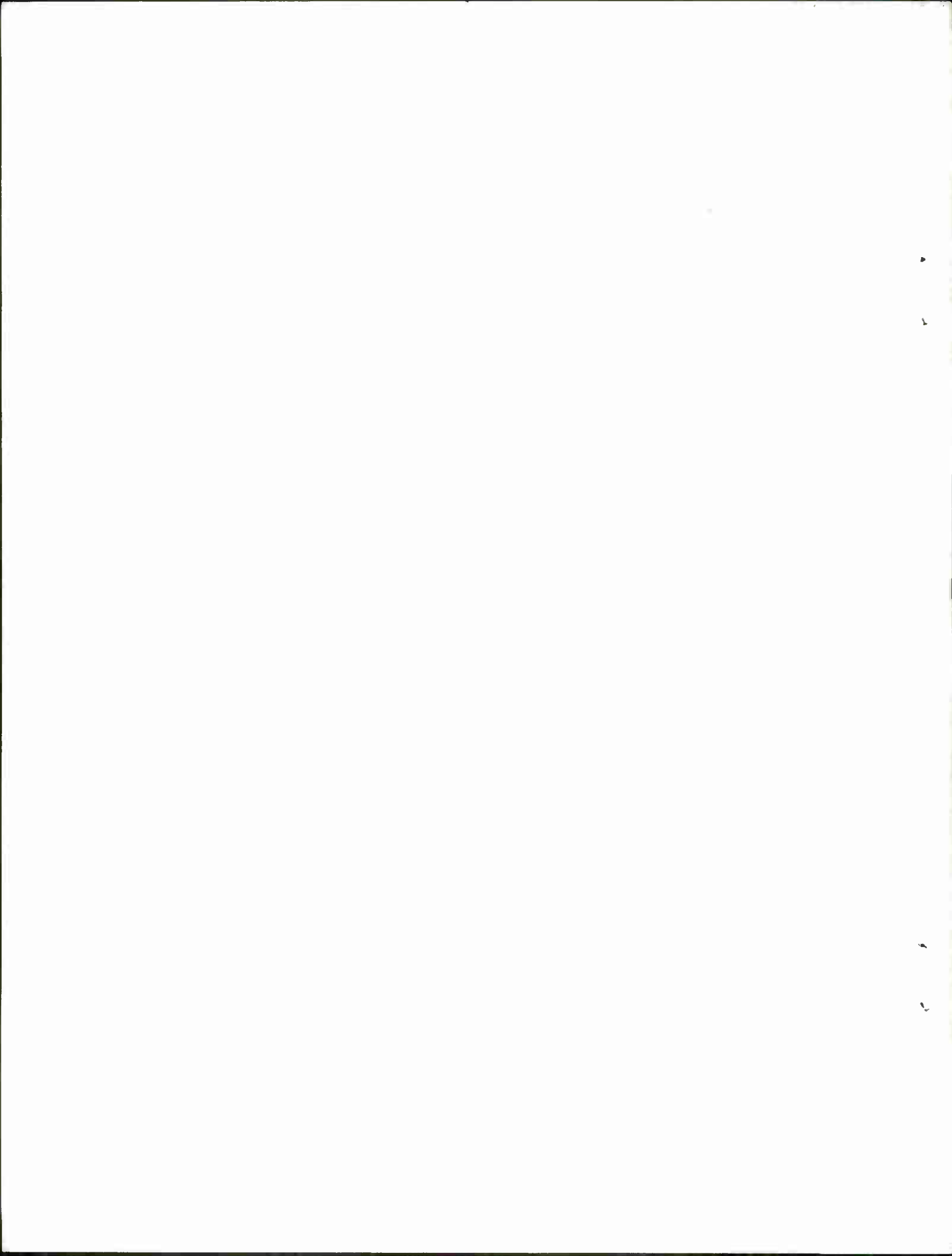

DISTRIBUTION LIST

<u>No. of</u> <u>Copies</u>	<u>Organization</u>	<u>No. of</u> <u>Copies</u>	<u>Organization</u>
2	Commander Defense Technical Info Center ATTN: DDC-DDA Cameron Station Alexandria, VA 22314	2	Commander US Army Aviation Research and Development Command ATTN: DRDAV-N, Mr. D. Weller DRSAV-E P. O. Box 209 St. Louis, MO 63166
1	ODUSDRE (R/AT) (ET) ATTN: Mr. Persh Room 3D1089, The Pentagon Washington, DC 20301	1	Director US Army Air Mobility Research and Development Laboratory Ames Research Center Moffett Field, CA 94035
1	HQDA (DAMA-CSM, LTC Germann) Room 3C443, The Pentagon Washington, DC 20310	1	Commander US Army Communications Rsch and Development Command ATTN: DRDCO-PPA-SA Fort Monmouth, NJ 07703
1	Commander US Army Materiel Development and Readiness Command ATTN: DRCLDC, Mr. T. Shirata 5001 Eisenhower Avenue Alexandria, VA 22333	2	Commander US Army Electronics Research and Development Command Technical Support Activity ATTN: DELSD-L DELS-EM, Mr. Nolan Fort Monmouth, NJ 07703
1	Commander US Army Materiel Development and Readiness Command ATTN: DRCSA-JS, COL Henne 5001 Eisenhower Avenue Alexandria, VA 22333	1	Commander/Director Ofc of Missile Electronics Warfare (ERADCOM) US Army Electronic Warfare Lab ATTN: DELEW-M-MS, Ms. Arthur White Sands Missile Range NM 88002
2	Commander US Army Armament Research and Development Command ATTN: DRDAR-TSS Dover, NJ 07801	3	Commander US Army Missile Command ATTN: DRDMI-R DRDMI-YDL DRSME-Z (RND), R. Vaughn Redstone Arsenal, AL 35809
1	Commander US Army Armament Materiel Readiness Command ATTN: DRSAR-LEP-L, Tech Lib Rock Island, IL 61299		
1	Director US Army ARRADCOM Benet Weapons Laboratory ATTN: DRDAR-LCB-TL Watervliet, NY 12189		

DISTRIBUTION LIST

<u>No. of Copies</u>	<u>Organization</u>	<u>No. of Copies</u>	<u>Organization</u>
1	Commander US Army Mobility Equipment Research & Development Cmd ATTN: DRDME-WC, H. Barker Fort Belvoir, VA 22060	1	Commander Naval Air Systems Command ATTN: AIR-350, E. Fisher Washington, DC 20361
1	Commander US Army Tank Automotive Research & Development Cmd ATTN: DRDTA-UL Warren, MI 48090	1	Commander Naval Sea Systems Command ATTN: SEA 035, Mr. G. Sorkin Crystal Mall, Bldg. 4 Washington, DC 20360
1	Commander US Army Dugway Proving Ground ATTN: STEDP-MT-S Mr. J. Trethewey Dugway, UT 84022	1	Commander Naval Intelligence Support Ctr ATTN: Code 43, Mr. St. Aubin 4301 Suitland Road Washington, DC 20390
1	Director US Army Foreign Science and Technology Center ATTN: DRXST-MT1 Mr. Schlesinger 220 Seventh Street Charlottesville, VA 22902	1	Commander David W. Taylor Naval Ship Research & Development Ctr ATTN: Code 2714, D. Carey Annapolis Laboratory Annapolis, MD 21402
1	Director US Army Materials and Mechanics Research Center ATTN: DRXMR-R, Dr. G. Thomas Watertown, MA 02172	3	Commander Naval Surface Weapons Center ATTN: Code CF-56 Mr. Gene Gallaher Mr. Raymond Polcha Dr. Robert Amadori Dahlgren, VA 22448
1	Director US Army TRADOC Systems Analysis Activity ATTN: ATAA-SL, Tech Lib White Sands Missile Range NM 88002	1	USAF/RDPE (LTC R. Halder) Rm 5C470, The Pentagon Washington, DC 20330
1	Commander Naval Material Command ATTN: Code MAT-08T321 Dr. Herber Moore Washington, DC 20362	1	AFSC/DLAW (MAJ F. Zak) Andrews AFB, DC 20334
		1	AFSC/XRLW (MAJ L. Curtis) Andrews AFB, DC 20334
		1	AFATL/DLJW (Mr. Glendenning) Eglin AFB, FL 32542

DISTRIBUTION LIST

<u>No. of Copies</u>	<u>Organization</u>	<u>No. of Copies</u>	<u>Organization</u>
1	RADC/RBQ (Mr. Q. Porter) Griffiss AFB, NY 13441	1	DOT/TAC ATTN: Mr. K. Hergenrother/332 Kendall Square Cambridge, MA 02142
1	AFISC/SEFB (Mr. J. Tilson) Norton AFB, CA 92409	1	Director National Aeronautics and Space Administration Ames Research Center ATTN: J. Mansfield Moffett Field, CA 94035
1	AFISC/SEFB (MAJ T. Allocca) Norton AFB, CA 92409	1	Director Jet Propulsion Laboratory ATTN: Mr. Kirk Dawson Chief, Control and Energy Conversion Division 4800 Oak Grove Drive Pasadena, CA 91103
1	AFLC/MAX (COL Thogersen) Wright-Patterson AFB, OH 45433	25	PM, GFRAP NASA Langley Research Center ATTN: Mr. R. Huston MS 231 Hampton, VA 23665
1	AFML/MBC (Mr. W. H. Gloor) Wright-Patterson AFB, OH 45433	1	Director National Aeronautics and Space Administration Lewis Research Center ATTN: Dr. T. Serafini 21000 Brookpark Road Cleveland, OH 44135
1	FTD/TQTD (Mr. C. Butler) Wright-Patterson AFB, OH 45433	1	Director National Aeronautics and Space Administration Marshall Space Flight Center ATTN: R. Schwinghammer Huntsville, AL 35812
1	Office of Science and Technology Policy ATTN: COL Kay Old Executive Office Building Room 481 17th St & Pennsylvania Avenue Washington, DC 20500	1	Advanced Systems Technology Westinghouse Electric Corp ATTN: Mr. Stephen F. Mauser E. Pittsburgh, PA 15112
1	Federal Emergency Management Agency (FEMA) Plans and Preparedness ATTN: Mr. John Nocita Washington, DC 20301		
1	Environmental Protection Agency ATTN: Mr. F. Mayo 26 West St. Clair Street Cincinnati, OH 45268		
1	Environmental Sciences Research Laboratory Environmental Protection Agency ATTN: Dr. J. Wagman Research Triangle Park, NC 27711		

DISTRIBUTION LIST

<u>No. of Copies</u>	<u>Organization</u>	<u>No. of Copies</u>	<u>Organization</u>
1	Arthur D. Little, Inc. ATTN: Dr. A. Kalelkar 25 Acorn Park Cambridge, MA 02140	1	Mitre Corporation ATTN: Mr. P. Ware P. O. Box 208 Bedford, MA 01730
1	AVCO Corporation Specialty Materials Division ATTN: E. Bellason, Director of Fire Products #2 Industrial Avenue Lowell, MA 08151	1	ORI ATTN: Dr. L. Pocinki Executive Scientist 1400 Spring Street Silver Spring, MD 20910
1	The Bionetics Corporation ATTN: Israel Taback NASA Langley Research Center Mail Stop 231 Hampton, VA 23669	1	TRW Defense & Space Systems Group of TRW, Inc. ATTN: P. Lieberman, RI/1112 One Space Park Redondo Beach, CA 90278
1	Boeing Commercial Airplane Co. ATTN: J. McMillian Mail Code 77-28 Seattle, WA 98121	1	George Washington University School of Engineering & Applied Science ATTN: Dr. D. Gross Washington, DC 20052
1	Douglas Aircraft Corporation ATTN: Dr. H. Schjelderup Dept. 253, 35-14 3855 Lakewood Boulevard Long Beach, CA 90846		<u>Aberdeen Proving Ground</u> Dir, USAMSAA ATTN: DRXSJ-D DRXSJ-MP, H. Cohen
1	Lockheed-California Company ATTN: Mr. J. Koch Dept. 75-71-B-90 P. O. Box 551 Burbank, CA 91520		Cdr, USATECOM ATTN: DRSTE-TO-F Dir, Wpns Sys Concepts Team, Bldg. E3516, EA ATTN: DRDAR-ACW

USER EVALUATION OF REPORT

Please take a few minutes to answer the questions below; tear out this sheet and return it to Director, US Army Ballistic Research Laboratory, ARRADCOM, ATTN: DRDAR-TSB, Aberdeen Proving Ground, Maryland 21005. Your comments will provide us with information for improving future reports.

1. BRL Report Number _____

2. Does this report satisfy a need? (Comment on purpose, related project, or other area of interest for which report will be used.)

3. How, specifically, is the report being used? (Information source, design data or procedure, management procedure, source of ideas, etc.) _____

4. Has the information in this report led to any quantitative savings as far as man-hours/contract dollars saved, operating costs avoided, efficiencies achieved, etc.? If so, please elaborate.

5. General Comments (Indicate what you think should be changed to make this report and future reports of this type more responsive to your needs, more usable, improve readability, etc.) _____

6. If you would like to be contacted by the personnel who prepared this report to raise specific questions or discuss the topic, please fill in the following information.

Name: _____

Telephone Number: _____

Organization Address: _____

•

,

•

2

1000

1000

1000