

UNCLASSIFIED

AD NUMBER

ADB049384

LIMITATION CHANGES

TO:

Approved for public release; distribution is unlimited.

FROM:

Distribution authorized to U.S. Gov't. agencies only; Test and Evaluation; APR 1980. Other requests shall be referred to Rome Air Development Center, Attn: DCLT, Griffiss AFB, NJ 13441.

AUTHORITY

RADC, USAF ltr, 11 May 1981

THIS PAGE IS UNCLASSIFIED

**THIS REPORT HAS BEEN DELIMITED
AND CLEARED FOR PUBLIC RELEASE
UNDER DOD DIRECTIVE 5200.20 AND
NO RESTRICTIONS ARE IMPOSED UPON
ITS USE AND DISCLOSURE.**

DISTRIBUTION STATEMENT A

**APPROVED FOR PUBLIC RELEASE,
DISTRIBUTION UNLIMITED.**

LEVEL

2

**RADC-TR-80-125, Vol III (of three)
Final Technical Report
April 1980**



**MODULAR C³ INTERFACE ANALYSIS
(FLEXIBLE INTRACONNECT)
EXECUTIVE SUMMARY**

AD B O 4 9 3 8 4

Martin Marietta Corporation.

William G. Bedsole
William F. Kamsler, et al

DTIC
ELECTE
AUG 4 1980
S D C

DISTRIBUTION LIMITED TO U.S. GOVERNMENT AGENCIES ONLY; TEST AND EVALUATION; April 1980 . OTHER REQUESTS FOR THIS DOCUMENT MUST BE REFERRED TO RADC (DCLT), GRIFFISS AFB NY 13441.

**ROME AIR DEVELOPMENT CENTER
Air Force Systems Command
Griffiss Air Force Base, New York 13441**

80 8 1 087

DISCLAIMER NOTICE

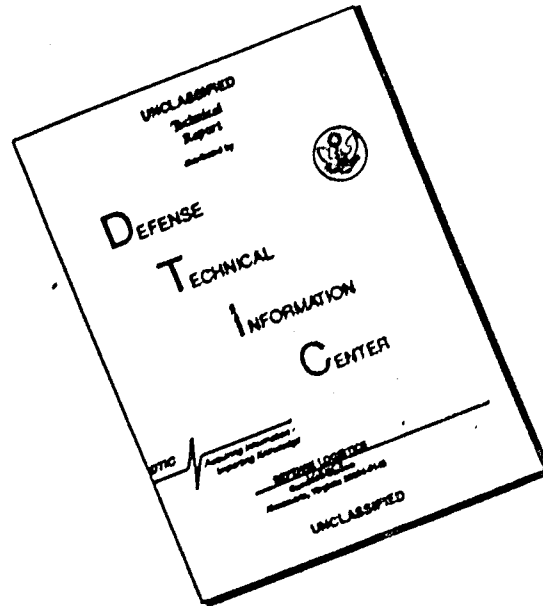

THIS DOCUMENT IS BEST QUALITY AVAILABLE. THE COPY FURNISHED TO DTIC CONTAINED A SIGNIFICANT NUMBER OF PAGES WHICH DO NOT REPRODUCE LEGIBLY.

This report consists of three volumes. Because of the size of Volume I, it has been divided into two parts. Part 1 contains the basic report and Appendices A through C. Part 2 contains Appendix D.

Volume II, which is classified can be obtained from RADC (DCLT) Griffiss AFB NY 13441.

Volume III of this report references the following classified document:

Modular C³ Interface Analysis (Flexible Intraconnect), Volume II, Considerations (U) dated October 1979, SECRET.

RADC-TR-80-125, Volume III (of three) has been reviewed and is approved for publication.

APPROVED: 
JAMES L. DAVIS
Project Engineer

APPROVED: 
FRED I. DIAMOND
Technical Director
Communications and Control Division

FOR THE COMMANDER: 
JOHN P. HUSS
Acting Chief, Plans Office

If your address has changed or if you wish to be removed from the RADC mailing list, or if the addressee is no longer employed by your organization, please notify RADC (DCLT) Griffiss AFB NY 13441. This will assist us in maintaining a current mailing list.

Do not return this copy. Retain or destroy.

(19) TR-80-125-VOL-3

UNCLASSIFIED

SECURITY CLASSIFICATION OF THIS PAGE (When Data Entered)

REPORT DOCUMENTATION PAGE		READ INSTRUCTIONS BEFORE COMPLETING FORM
1. REPORT NUMBER ⑱ RADC-TR-80-125, Vol III (of three)	2. GOVT ACCESSION NO. AD-B049 3844	3. RECIPIENT'S CATALOG NUMBER
4. TITLE (and Subtitle) ⑥ MODULAR C ³ INTERFACE ANALYSIS (FLEXIBLE INTRACONNECT). Volume 3- Executive Summary.	5. TYPE OF REPORT & PERIOD COVERED ⑨ Final Technical Report, Oct 77 - Jul 79.	6. PERFORMING ORG. REPORT NUMBER ⑭ MCR-79-1411-VOL-3
7. AUTHOR(s) ⑩ William G. Bedsole William F. Kamsler	Denmet/Baxter James/Billar James KUMMILL	8. CONTRACT OR GRANT NUMBER(s) ⑮ F19628-77-C-0262
9. PERFORMING ORGANIZATION NAME AND ADDRESS Martin Marietta Corporation Denver Division PO Box 179, Denver CO 80201	10. PROGRAM ELEMENT, PROJECT, TASK AREA & WORK UNIT NUMBERS 63789F ⑯ 23170102	11. REPORT DATE ⑪ Apr 80
11. CONTROLLING OFFICE NAME AND ADDRESS Rome Air Development Center (DCLT) Griffiss AFB NY 13441	12. REPORT DATE ⑫ 23	13. NUMBER OF PAGES 16
14. MONITORING AGENCY NAME & ADDRESS (if different from Controlling Office) Same	15. SECURITY CLASS. (of this report) UNCLASSIFIED	16. DECLASSIFICATION/DOWNGRADING SCHEDULE N/A
16. DISTRIBUTION STATEMENT (of this Report) Distribution limited to U.S. Government agencies only; test and evaluation; April 1980. Other requests for this document must be referred to RADC (DCLT), Griffiss AFB NY 13441.		
17. DISTRIBUTION STATEMENT (of the abstract entered in Block 20, if different from Report) Same		
18. SUPPLEMENTARY NOTES: RADC Project Engineer: James L. Davis (DCLT) This report was prepared in parallel with a separate Flexible Intraconnect design definition study conducted by Hughes Aircraft Company under F19628-77-C-0261, work unit 23170101. (see reverse)		
19. KEY WORDS (Continue on reverse side if necessary and identify by block number) Time Division Multiple Access Fiber Optics Data Communications Data Bus Communications Local Communications Networks Tactical Command and Control Network Protocols Command, Control and Communications Data Transmission		
20. ABSTRACT (Continue on reverse side if necessary and identify by block number) This report documents the preliminary design for a high capacity wide-band general purpose data/communications busing system. The bus, called a "Flexible Intraconnect," will be used to achieve modularity in the design, implementation and deployment of command, control and communications (C ³) centers of the Tactical Air Force (TAP). FI design requirements were established by estimates of traffic loads for current and future (through 1980) configurations of Tactical Air Control System		

DD FORM 1 JAN 73 1473

EDITION OF 1 NOV 65 IS OBSOLETE

UNCLASSIFIED

SECURITY CLASSIFICATION OF THIS PAGE (When Data Entered)

40E 20.5

UNCLASSIFIED

SECURITY CLASSIFICATION OF THIS PAGE(When Data Entered)

(TACS) C³ centers of the TAF. Surveys of data distribution system architectures, current and developing technologies, and device interfaces are provided. A design of a Flexible Intraconnect having high transmission rate and capacity, positive flow control and configuration flexibility is described. A standardized interface for physical and functional device to bus access is described. Description of the major functional elements of the FI are provided along with top level block diagnosis. The design was analyzed and preliminary estimates of error performance, reliability, capacity and response times were developed.

Block 18 cont'd

This report consists of three volumes. Because of the size of Volume I, it has been divided into two parts. Part 1 contains the basic report and Appendices A through C. Part 2 contains Appendix D.

Volume II, which is classified can be obtained from RADC (DCLT) Griffiss AFB NY 13441.

Volume III contains the Executive Summary.

Accession For	
NTIS GRA&I	<input checked="" type="checkbox"/>
DDC TAB	<input type="checkbox"/>
Unannounced	<input type="checkbox"/>
Justification	<input type="checkbox"/>
By _____	
Distribution	
Availability	
Dist	
B	

UNCLASSIFIED

SECURITY CLASSIFICATION OF THIS PAGE(When Data Entered)

PREFACE

This report has been prepared by the Martin Marietta Corporation for the Communications and Control Division of the Rome Air Development Center in accordance with Contract F19628-77-C-0262. The work reported herein consists of Task I, Task II, and Task III of Phase I of an on-going design study being conducted by the Air Force to develop a Flexible Intraconnect for tactical C3 equipment connectivity.

As evidenced by the quantity of analyses performed and documented during the period of this study, many individual specialists contributed significantly toward achievement of these results. Martin Marietta personnel who participated in this study were:

William F. Kamsler - Task III Project Manager
William Bedsole - Task I and II Project Manager

Dr. Denner Baxter	Joel Horrell
James Billars	James Jones
James Burrill	Cameron MacDonald
Esther Connors	Chris Martinson
Rose Cress	George McClure
William Dudley	Louise McFadden
Richard Endicott	Peter Miller
Linda Fulmer	Douglas Noden
Lenard Funck	Christian Pfitzer
Roy Gilbreath	Howard Ritchie
James Hayne	William Robertson
John Hebel	David Sully
W. Raymond Herbert	William Tyrlick
Louis Horkan	

During the course of the study, the contractor received excellent support from many Government offices in obtaining background documents and information required for completion of the analyses. A particular note of appreciation is expressed to the following persons:

James Davis, RADC	Major Robert Riopelle, TAFIG
David Griffith, RADC	Capt. Jon Campbell, TAFIG
John McLean, RADC	Wayne Chauffe, AFCSC
Waite Lee, MITRE	Robert Carto, NSA

CONTENTS

	<u>Page</u>
1.0 INTRODUCTION	1
2.0 DEFINITION	1
3.0 OBJECTIVE	2
4.0 BACKGROUND	3
5.0 ANALYSIS TASKS	4
5.1 Task I	4
5.2 Task II	4
5.3 Task III	5
6.0 SUMMARY	6
6.1 Local Intraconnect	6
6.2 External Intraconnect	8
6.3 Data Transfer Protocols	10
6.4 Data Transfer Scenario	13
6.4.1 Local Intraconnect	14
6.4.2 External Intraconnect	16
7.0 FI SYSTEM DETAILS	16

LIST OF ILLUSTRATIONS

<u>Figure</u>	<u>Page</u>
1 Control and Reporting Center	1
2 Implementation of Recommended System	6
3 Local Intraconnect	7
4 External Intraconnect Topology	8
5 External Intraconnect Unit	9
6 Data Transmission Control	11
7 Levels of Protocol	12
8 Formats at Each FI Level	12
9 Flexible Intraconnect Example	13
10 Data Transfer Functional Flow	14
11 Buffer Availability Determination	15

EXECUTIVE SUMMARY

1.0 INTRODUCTION

This Executive Summary highlights the key elements and conclusions reached during Modular C³ Interface Analyses performed by Martin Marietta Corporation from October 1977 through June 1979 on a study contract for the Rome Air Development Center (RADC) to define a Flexible Intraconnect capability for tactical command, control, and communications (C³) Systems.

This study was conducted under Project 2317, "Tactical Information Processing and Distribution", which is part of Program Element 63789F "Command, Control and Communications (C³) Advanced Development." The study is referred to as the "Flexible Intraconnect", which more aptly describes the task of intraconnecting C³ equipments..

2.0 DEFINITION

A Flexible Intraconnect (FI) is defined as a common transmission capability that may be accessed by all communications and automatic data processing devices within a tactical air force command and control center. The Control and Reporting Center (CRC) shown in Figure 1 is a typical center with a concentration of C³ equipments deployed in a shelter-based configuration to support air operations.

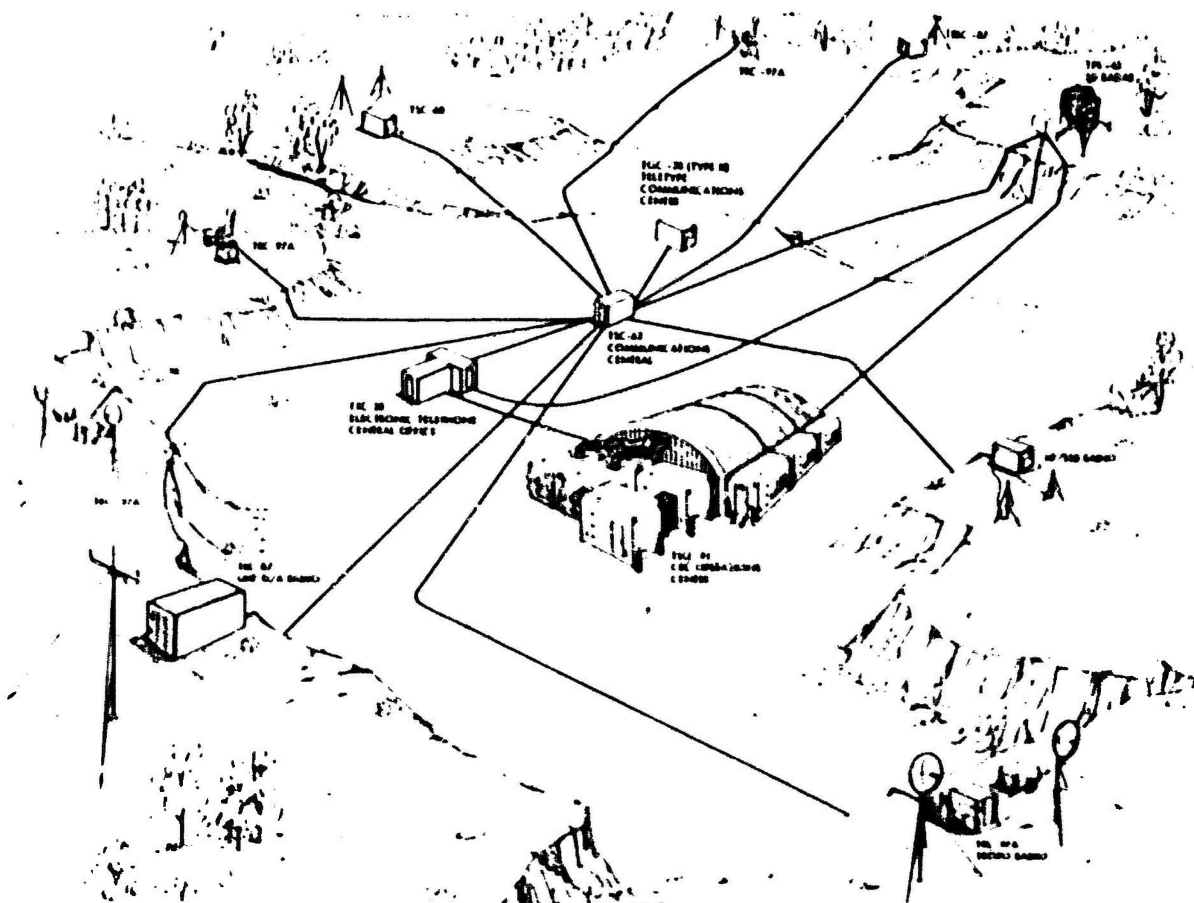

Figure 1. Control and Reporting Center.

3.0 OBJECTIVE

The objective of the study has been to perform analyses as necessary to define the most effective design concept to implement an FI capability. The developed capability for C³ facilities provides operational users with the flexibility to configure for current and future requirements. This intra-connect would become the foundation of Air Force programs concerned with development and fielding of tactical modular C³ facilities. Its design emphasizes modularity, interoperability, interconnectivity, flexibility and survivability. The design supports information exchange between tactical C³ facilities as C³ equipments and employment concepts evolve from those currently used to those which may exist in the year 2000. The design concept is applicable to existing systems such as the 407L Tactical Air Control System. The conceptual design is compatible with the architectures of the Defense Communication System (DCS), Worldwide Military Command and Control System (WWMCCS), Joint tactical Communications Program (JRI-TAC), and other systems currently under development such as the Joint Tactical Information Distribution System (JTIDS) and 485L Tactical Air Control System Improvements (TACSI).

The design is capable of expansion and growth to accommodate evolving concepts such as computer resource sharing, distributed data base/management, packet switching, bus concepts, information distribution, radar netting, modular operations centers, and geographically distributed functions.

The proposed design meets objectives for a wideband Flexible Intra-connect for Tactical Air Force modular C³ facilities and is suitable for deployment either in a static theater environment or a tactical deployment situation.

4.0 Background.

Tactical users of C³ centers have recognized the need to improve the methods for interconnecting equipment in these facilities. The most common problems associated with the current intraconnect methods, using multiconductor cable, may be summarized as:

- a. Converting incompatible interface characteristics to allow compatible interoperation between dissimilar devices
- b. Inability to change a center's configuration
- c. Inability to upgrade the automatic data processing (ADP) system by substitution of a single device such as the CPU without reengineering the intraconnect for the entire ADP system and replacement of many of the peripherals
- d. Inability to permit peripherals at remote locations to access the central processing unit (CPU) data base
- e. Excessive setup and teardown times
- f. Weight and size of cable harnesses
- g. Security vulnerability, and
- h. Low reliability, primarily due to connector failures.

An important step in solving these problems is the adoption of a common set of interface characteristics for future C³ systems. It is also important to provide compatible interfaces between current inventory devices, those soon to be fielded, and those to be developed. Initially, the new intraconnect will accommodate a variety of interface characteristics by providing compatibility conversions to match the characteristics of the common standard. Specifications for future C³ devices could easily include requirements to be compatible with FI Input/Output (I/O) characteristics in accordance with the standard interface.

5.0 ANALYSES

The following paragraphs summarize the analysis and conceptual design performed on the study of the FI.

5.1 Task I: This task's efforts were directed towards:

- a. Defining user requirements for the Flexible Intraconnect, and
- b. Selecting a design concept for implementation of the Flexible Intraconnect.

The analysis addressed the problem of information transfer within a center, i.e., within each shelter and among the shelters that constitute the center. Designer investigations were performed at the level of detail necessary to compare the cost effectiveness of candidate concepts.

The requirements analyses examined the time-phased scenarios of C3 equipment the Flexible Intraconnect must support, and provided quantification of traffic flow for both communications and Automatic Data Processing (ADP) traffic within each of ten equipment center types. Maximum peak traffic load for a Local Intraconnect within a shelter was estimated to approach 150 Megabits per second (Mb/s). Maximum traffic load for the External Intraconnect among shelters was also estimated to approach 150 Mb/s.

The recommended FI concept provides a two-level intraconnect, i.e., one level for local (intrashelter) traffic, and another for external (intracenter) traffic. The Local Intraconnect employs a conventional open-loop topology using forty twisted-pair ribbon cable for transmission, Time Division Multiplexing (TDM) for channelization, and sequential polling for user access.

The External Intraconnect employs a star topology using multichannel fiber optic cable for transmission, TDM-SDM for channelization, and polling for access control.

A three-phase implementation plan was described that would allow incremental development of the intraconnect, while providing intraconnect capabilities compatible with the requirements of the incremental evolution of C3 equipment.

5.2 Task II: This task's efforts were directed towards:

- a. Analyzing the interface characteristics of inventory and future C3 devices that interface with the Flexible Intraconnect
- b. Performing a functional design of the C3 device-to-Flexible Intraconnect interface
- c. Preparing a Preliminary Interface Standard document to establish a design standard for the C3 device-to-Flexible Intraconnect interface, and
- d. Verifying the capability of the Flexible Intraconnect Concept to satisfy the intraconnect requirements of the revised Tactical Air Forces Integrated Information System (TAFIIS) Master Plan.

The interface characteristics of all communications and ADP devices expected to access the intraconnect were compiled and analyzed to determine the device-to-Local Intraconnect Unit (LIU) interface requirements.

Existing interface standards were studied to determine similarities with the requirements identified for the device-to-LIU interface. At the same time, analyses were performed to further define the functional operation of the LIU, identify the characteristics of the LIU-to-Local Intraconnect (LI) interface, and to perform a preliminary functional design of the LIU and the adapters. Outputs of these subtasks enabled selection of characteristics for the interface standard to be applied at the point of interface between the LIU and the ADP or communications device. A Preliminary Interface Standard document was prepared to describe the characteristics of the recommended interface.

A concept verification effort was performed confirming that the recommended Flexible Intraconnect concept will satisfy the intraconnect requirements of the C³ equipment scenario defined in the TAFIIS Master Plan.

5.3 Task III: This task's efforts were directed towards:

- a. Preliminary design of the intraconnect scheme and the subnetwork bus configurations
- b. Communication network implementation
- c. Development of message structure, protocols and formats
- d. Network control and resource management
- e. Security aspects relative to TEMPEST effects, intrusion, and eavesdropping, and
- f. Reliability, Maintainability, and Availability analyses.

The preliminary design study details operational facets of the FI and shows how recommended architecture handles point-to-point, virtual bus, lazy susan, and broadcast messages.

Control functions via the FI Manager were examined and message structure, protocols, and header formats were detailed. The interconnection of communication devices and their interface with other common-user communications were conceptually designed. Alternate configurations were presented to time phase communications into the FI.

Incorporation of encryption/decryption devices into the FI structure were thoroughly investigated.

A preliminary reliability, maintainability and availability analysis was made on the FI system to determine the degree of redundancy requirements that must be incorporated in the design to assure operational availability.

A throughput analysis has been prepared to verify system response time and determine probability of data blockage.

6.0 SUMMARY

The recommended Flexible Intraconnect concept employs a two-level bus transmission system. The Local Intraconnect bus carries traffic within a shelter. Figure 2 shows the configuration for this concept as envisioned for employment in C³ centers. The External Intraconnect bus carries traffic among shelters of a center. This bus consists of multichannel fiber optic cables arranged in a star topology to connect each equipment shelter with a centrally located fiber optic transponder with as many as 63 legs in the star configuration. Access to the External Intraconnect from a Local Intraconnect is supervised by the External Intraconnect Control Unit (EICU). Functions for interfacing between the External and Local Intraconnects are performed in the External Intraconnect Unit (EIU).

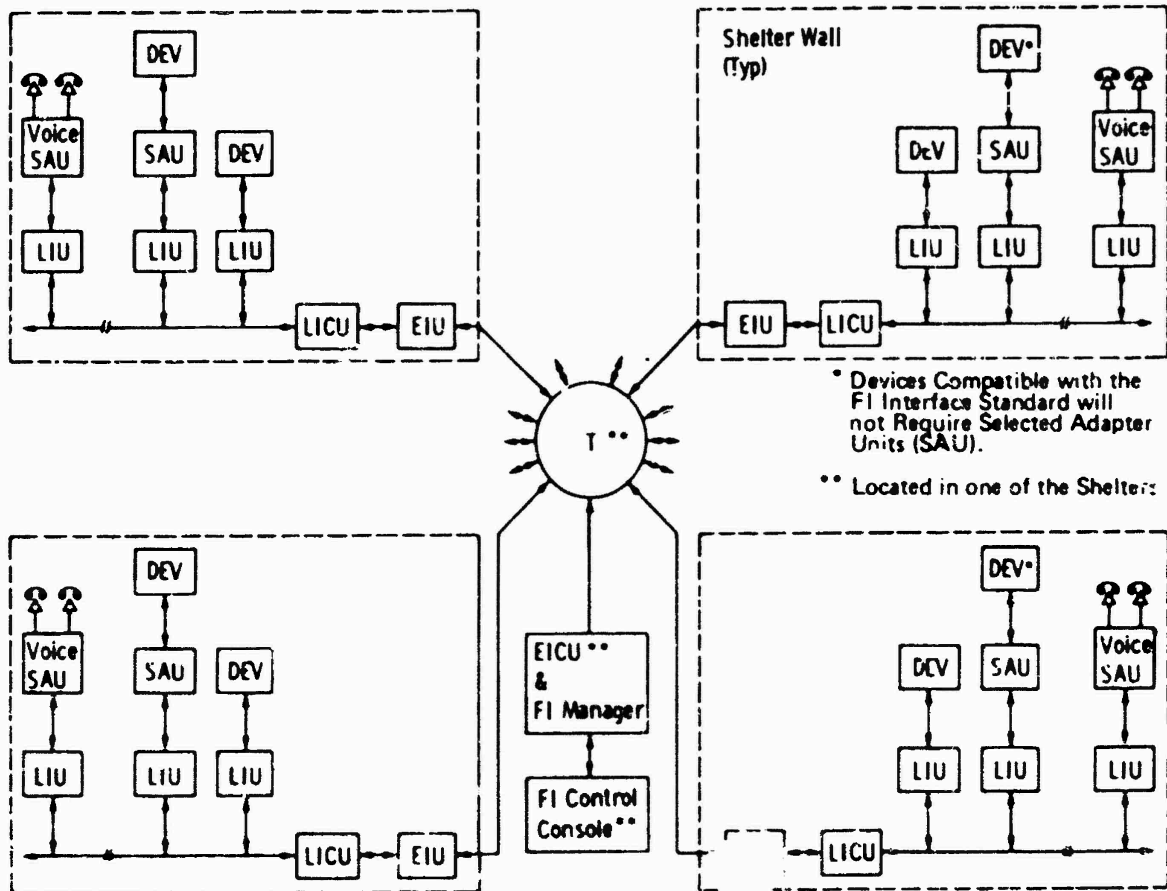

Figure 2. Implementation of Recommended System.

6.1 Local Intraconnect

Analysis efforts have concentrated on design characteristics of the Local Intraconnect; the point of interface with C³ devices and the application of the Interface Standard. Figure 3 shows the open-loop topology of the Local Intraconnect. The local Intraconnect bus consists of a forty

twisted-pair ribbon cable looped between communication and ADP devices within a shelter. Data transfer is in parallel at a 200 Mb/s rate. Devices access the Intraconnect by means of an LIU. The device side of the LIU will be designed to meet the characteristics of the Interface Standard. If the device Input/Output (I/O) interface characteristics are compatible with this Interface Standard, the device may be connected directly to the LIU. If not, the necessary compatibility conversions are performed by an adapter module. LIU access to the Local Intraconnect bus is controlled by the Local Intraconnect Control Unit (LICU). 63 LIUs can be serviced on the Local Intraconnect. The LICU polls each LIU to coordinate transmission of data blocks over the local bus.

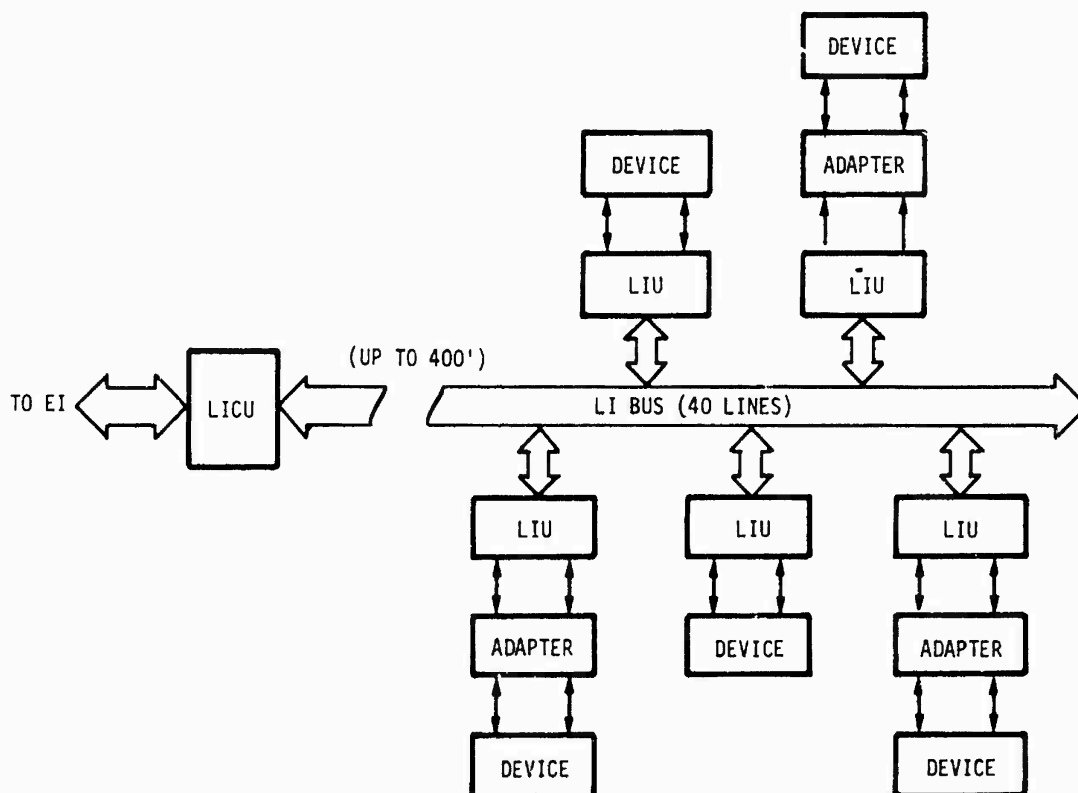

Figure 3. Local Intraconnect.

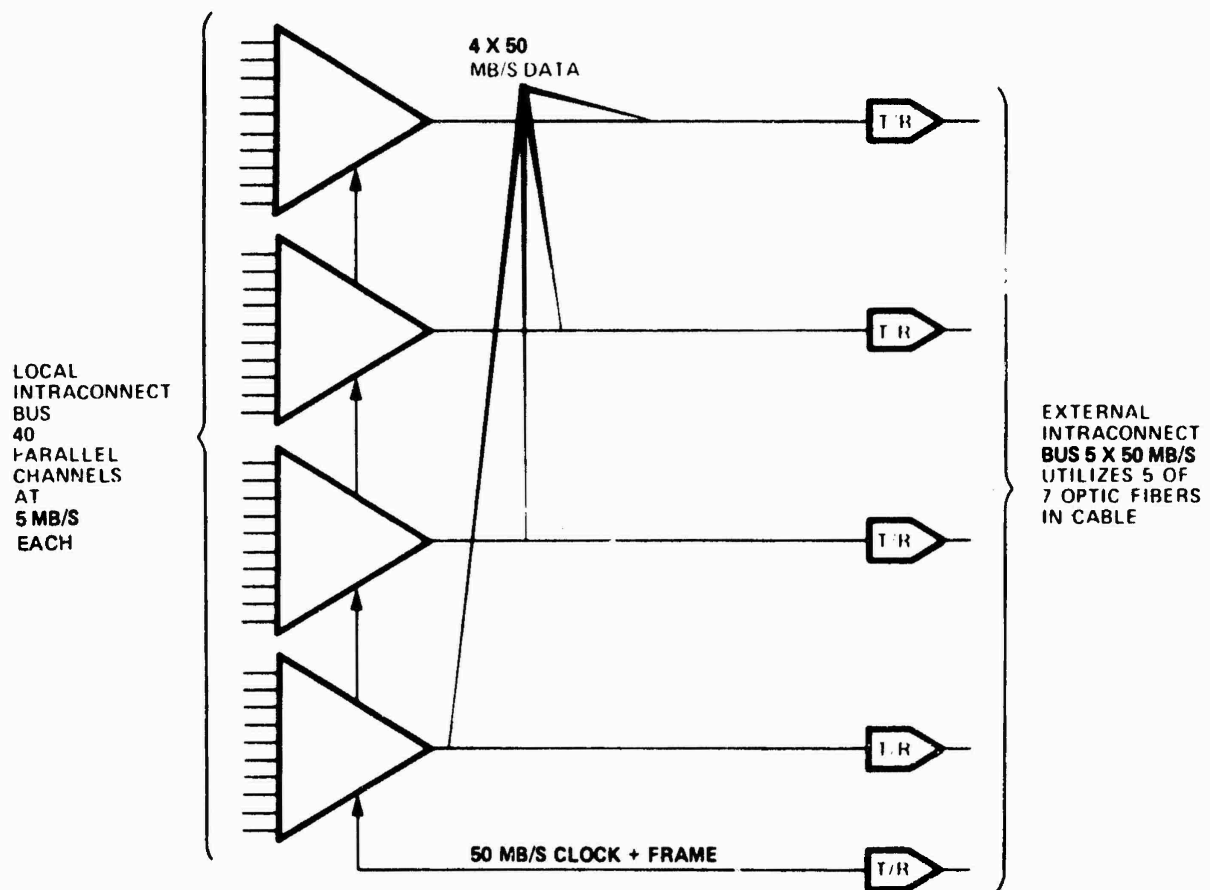

Figure 5. External Intraconnect Unit (EIU)

The proposed External Intraconnect, providing communications between shelters, uses fiber optic cables as the transmission means. Fiber optics were selected for the following reasons:

- a. Wide bandwidth
- b. Negligible crosstalk
- c. No common-mode or ground-loop problems
- d. Cable impervious to EMP or lightning disruption
- e. Fastest service restoration
- f. High link availability
- g. Smallest size, lowest weight of all candidates, and
- h. Lowest cost alternative now, with further cost reductions in prospect.

The External Intraconnect will intraconnect a maximum of 63 LICUs.

6.3 Data Transfer Protocols.

Considerable work has been done on the development of data transfer protocols. Protocols to control data transmission over the FI have been defined for all levels of communication. The overall view of data transmission control can be seen in Figure 6. The characteristics of data transmission on the FI can be described in both functional and operational terms. Figures 7 and 8 show the five different layers of protocol affecting data flow over the FI.

- a. FI Level A concerns user-to-user protocol, i.e., process control. This data transfer control governs activities between devices as if they were directly connected.
- b. FI Level B pertains to the formatting of address, control, and data to and from a DTE for interface to other DTEs. This protocol is mainly for control between adapters and would disappear when adapters are no longer needed.

The following three layers of protocol combine to perform end-to-end data transmission between users on the FI. They are unique to the FI.

- c. FI Level C concerns the data link between a DTE or SAU and the FI. Control information for operation on the FI is contained in a device header which is attached to a block of data by the DTE or SAU.
- d. FI Level D consists of the LI control. A network header and trailer are added to the device header and data block by the LIU. This provides information required to control LIU-LIU and LIU-LICU data transfers.
- e. Data transfer on the EI continues using the network header and trailer formulated at FI Level D. However, communication between the EICU and EIUs is required to configure the FI into a proper mode of operation. This warrants a separate layer of protocol - FI Level E - which pertains to the EI control.

FI Levels D and E are transparent to the user.

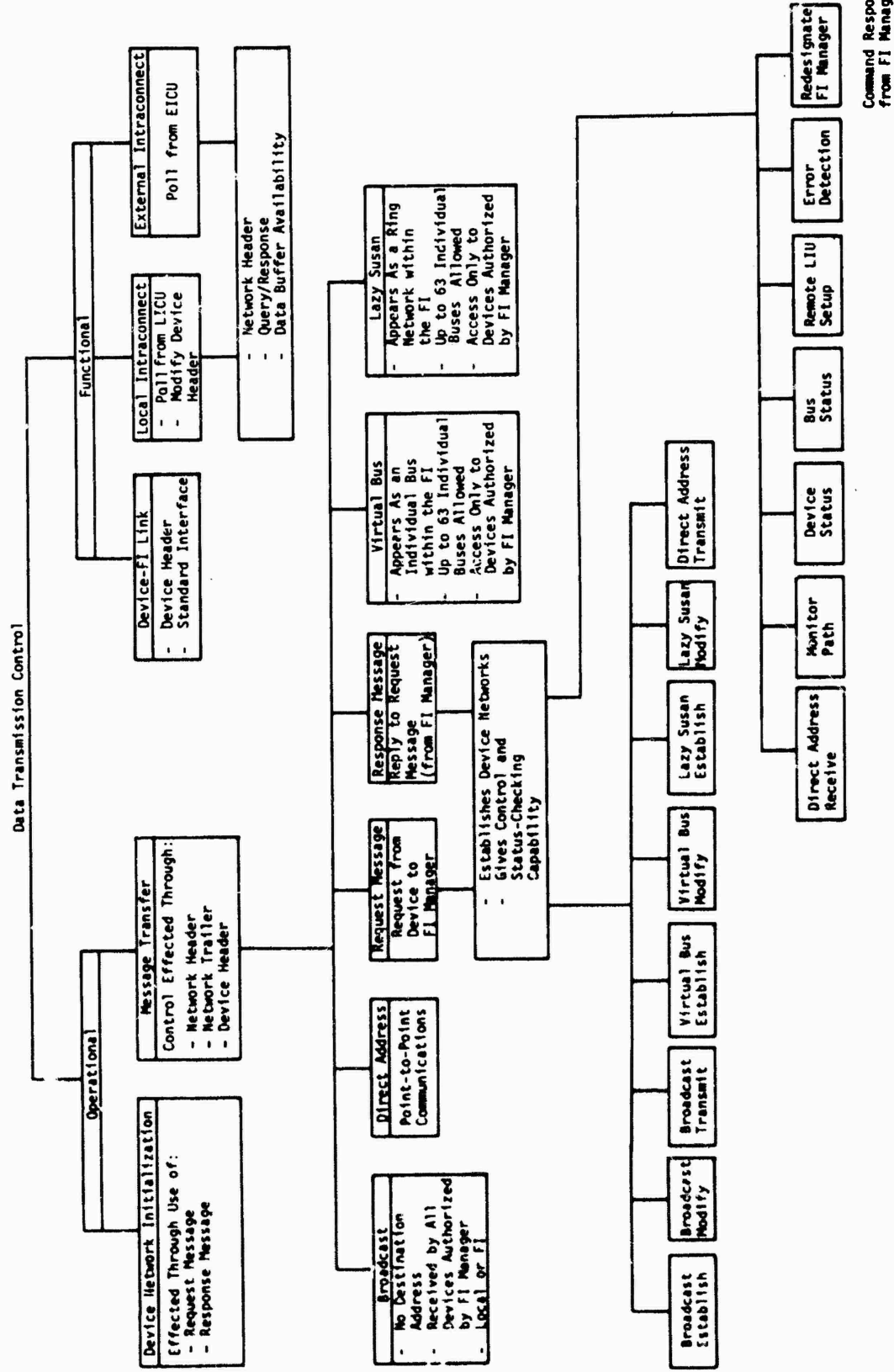

Figure 6.

Figure 6. Data Transmission Control.

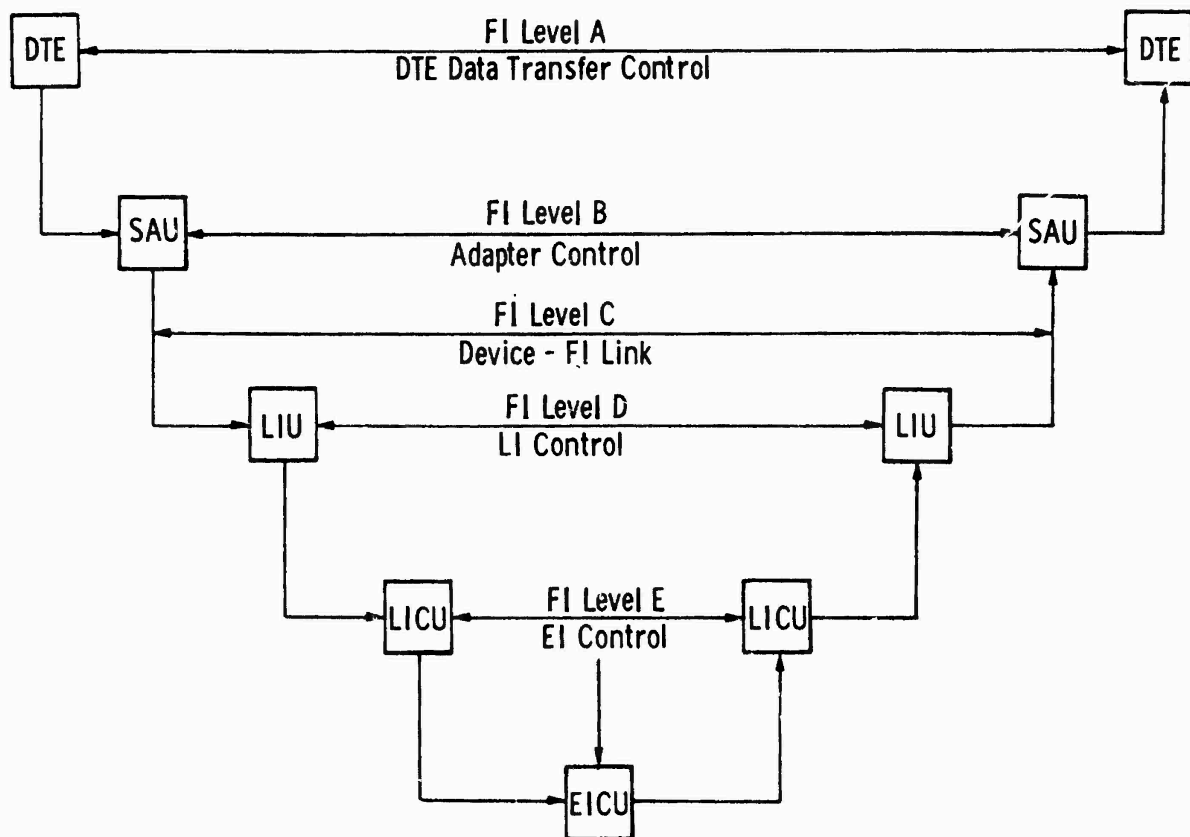

Figure 7. Levels of Protocol.

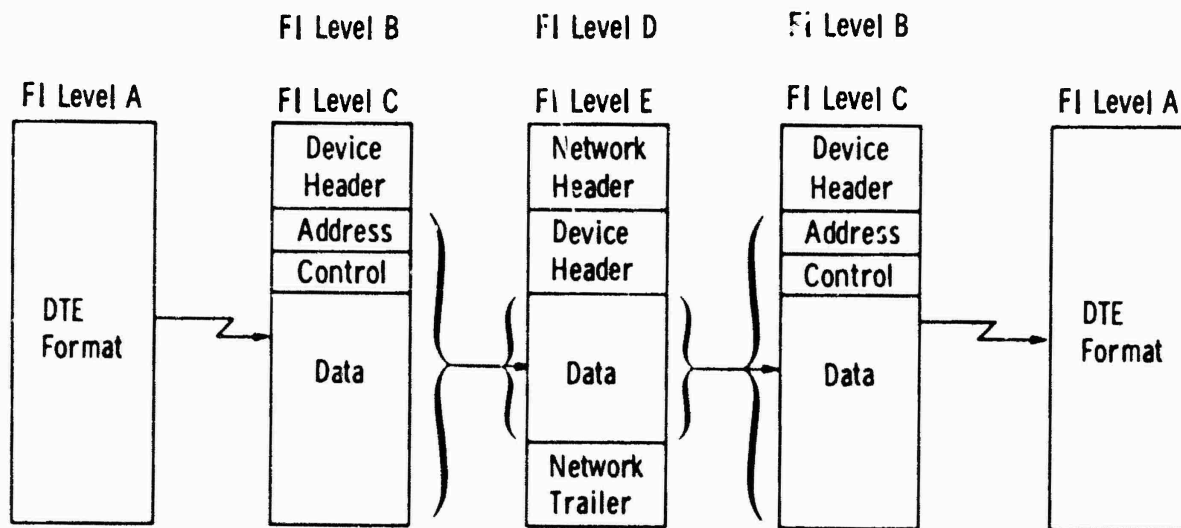

Figure 8. Formats at each FI Level.

6.4 Data Transfer Scenario.

The following scenario describes data transfer from DTE-1 to DTE-2. The referenced DTE-1, DTE-2, DTE-5, etc, are shown in Figure 9. The functional flow is depicted in Figure 10.

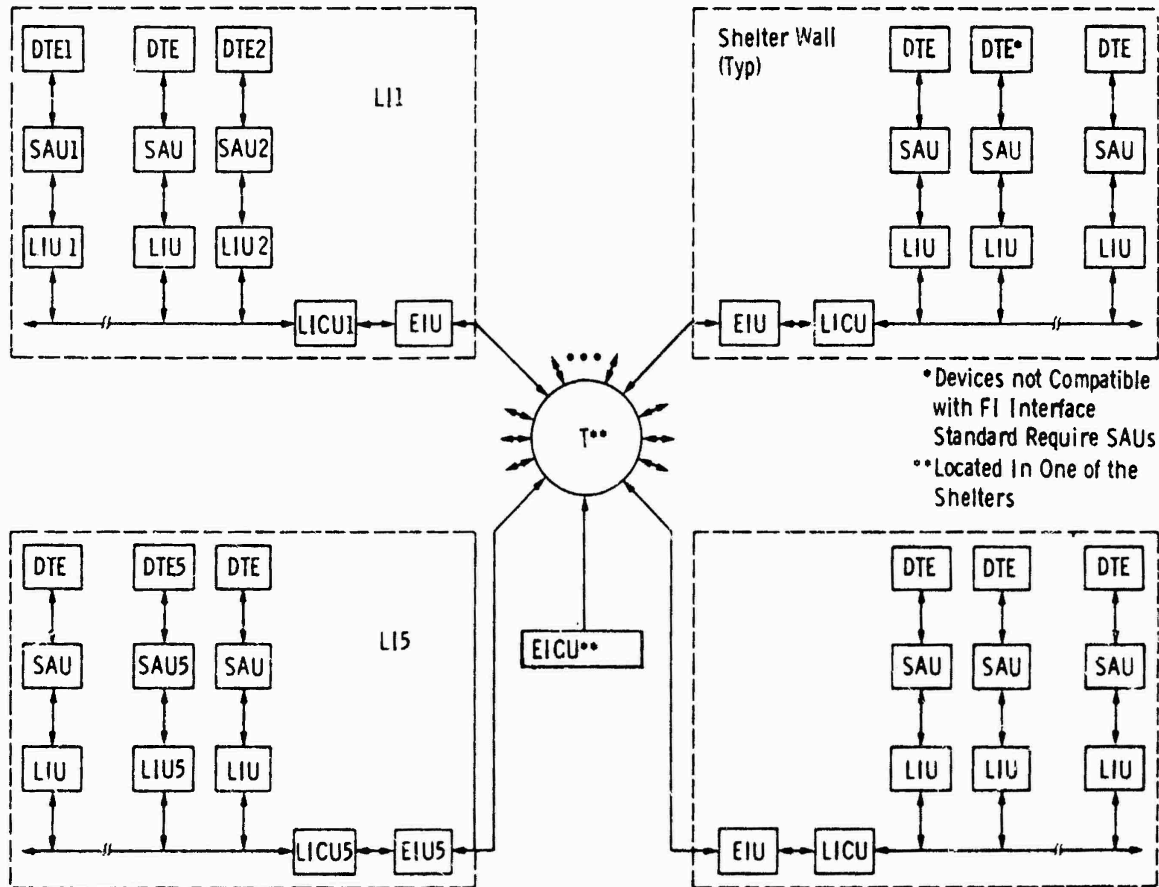

Figure 9. Flexible Intraconnect Example.

A DTE-1 wishing to transmit data on the FI attaches a device header to the block of data. This header provides control information required for DTE-DTE operation. The transfer of this header and data between the DTE and LIU is accomplished according to the interface standard. For present-day DTEs, a Special Adapter Unit (SAU) may be required for interface to the LIU. The DTE would transmit the data to the SAU as if directly connected to the destination DTE, (in this case, DTE2 or DTE5). The adapter, in turn, would structure this data for transmission to the LIU in accordance with the interface standard.

The header is transmitted to the LIU in DMA fashion with the block length always equal to sixteen 18-bit words. Transfer of the data field to the LIU is deferred until the LIU extracts the word count to determine the block length of the data, checks if the virtual address is valid, and tests the header for parity errors.

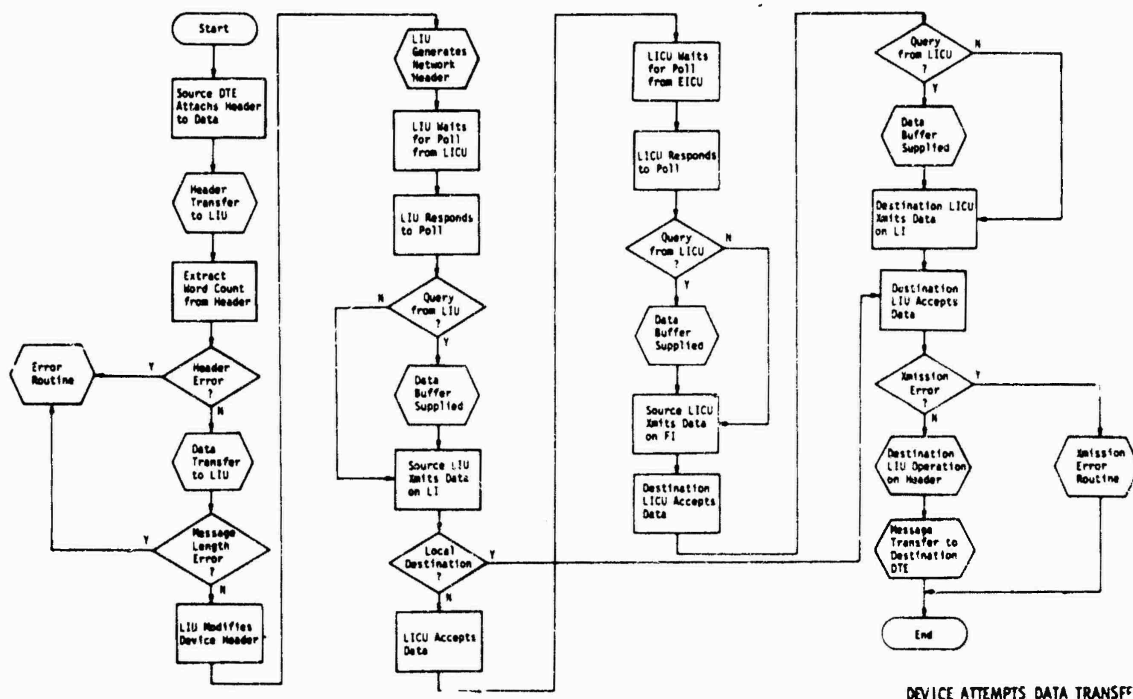

Figure 10. Data Transfer Functional Flow.

If an error is detected, the LIU formulates an error message to be transmitted to the FI Manager. If no error is detected, the rest of the message block, i.e., the data field, is transferred from the DTE to the LIU in DMA fashion. Three events must occur at the end of the data transfer: 1) the proper sign-off procedure as described in the interface standard takes place between the LIU and DTE/SAU; 2) the Input Data Request (IDR) line goes to inactive; and 3) the number of data words transferred compares to the message word count which was previously extracted from the device header. If an error is found in any of these events, an error message is formulated and sent to the FI Manager. If no error is detected, the LIU modifies the device header and header parity bit to each 8-bit byte, adding a date-time group, and changing the vertical parity to reflect these additions. The LIU also generates an FI network header for control of data transmission between FI components, e.g., LIU, LICU.

6.4.1 Local Intraconnect. The data packet is held by the transmitting LIU (LIU-1) until a poll is received from the LICU (LICU-1) which is continually polling all devices on its bus. The poll message sent from the LICU is stored in a buffer in each LIU until an accept/reject decision is made by the LIU, i.e., the LIU decides if the message is intended for it.

After accepting the poll message from the LICU, the LIU must respond with a message indicating if it has data ready for transmission. If not, the LICU continues to poll the other LIUs on its bus. The LIUs response to the poll depends on the type of message it is transmitting. If the message is a broadcast, a lazy susan, or for a virtual bus, the entire data block is transmitted on the LI by LIU-1. Any other message type requires a query from LIU-1 as to the availability of buffer space large enough to hold the data packet at the immediate destination (LIU for local traffic or LICU for

external). As shown in Figure 11, if the buffer is not available, the destination stores LIU-1's address in a queue (if not previously stored), then notifies LIU-1 of the buffer nonavailability. The purpose of storing the source's address is to assure that later-pollled LIUs will not gain access to the same destination before LIU-1. Buffer space will be allocated by the destination to LIU-1 according to its position in the stack. Meanwhile, the LICU will continue polling to expedite traffic on the bus. LIU-1 will transmit data to the destination LIU or LICU once it receives a poll after destination buffer space becomes available.

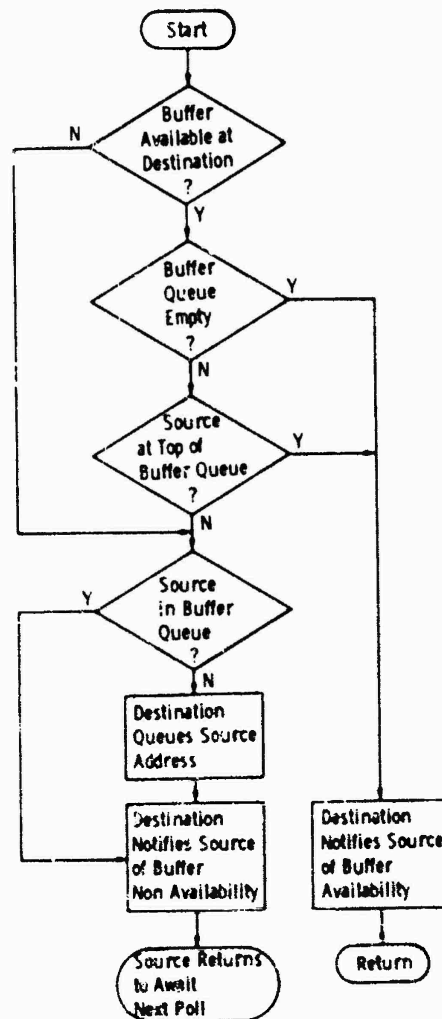

Figure 11. Buffer Availability Determination

If the destination is a DTE on the same bus (in this case, DTE-2), its associated LIU will store the message in one of its buffers. This LIU (LIU-2) will then check the network header for parity errors - vertical and horizontal - and verify the number of header words. Error checking will also be done on the data portion of the message block. If an error is detected in the network header, an error message is formulated by LIU-2 to be sent to the FI Manager. Error checking will also be done on the rest of the message block (device header and data). If an error is detected here, LIU-2 will formulate a

message notifying DTE-2 of the error. If the transmission is error-free, LIU-2 will extract the message length from the device header to set up the DMA transfer of the data to DTE-2. The device header and data is transmitted to DTE-2 in a DMA fashion according to the standard interface.

6.4.2 External Intraconnect. If the destination is a DTE on a different LI, such as in a separate shelter (in this case, DTE-5), LICU-1 will hold the message block until a buffer is available in EIU-1. LICU-1 then transfers the data to EIU-1 in DMA fashion according to the interface standard. EIU-1 will hold the message packet until it is polled by the EICU. The response by EIU-1 to the poll depends on the type of message it is transmitting. If the message is broadcast, lazy susan, or for a virtual bus, the entire data packet is transmitted on the FI by EIU-1. All other message types require a query from EIU-1 as to the availability of buffer space large enough to hold the data at the destination EIU (EIU-5). If buffer space is unavailable, EIU-5 stores EIU-1's address in a queue (unless previously stored), then notifies EIU-1 of the buffer nonavailability. As in the case of the LIUs, EIU-1 will be allocated buffer space in EIU-5 according to its position in the queue. The EICU will continue to poll the other EIUs in the network. EIU-1 will transmit data to EIU-5 upon receiving a poll after buffer space (in EIU-5) becomes available. Upon acceptance of the message, EIU-5 will transmit the data packet to LICU-5 when buffer space becomes available in LICU-5. The data is transferred from EIU-5 to LICU-5 in DMA fashion according to the interface standard. LICU-5 will then transmit the message block (if broadcast, lazy susan, or for a virtual bus) or a query as to the availability of buffer space in the destination LIU (LIU-5). Buffer nonavailability is treated as previously described - queuing of LICU-5's address in LIU-5, notification to LICU-5, and waiting for buffer availability before transmission of the message from LICU-5 to LIU-5. Upon acceptance of the data packet, LIU-5 checks for transmission errors as previously described for LIU-2. Again, if an error is found, an error message is formulated by LIU-5 and sent to the FI Manager and/or DTE-5. Otherwise, LIU-5 will set up the DMA transfer mode to DTE-5 and transmit the device header and data according to the interface standard.

7.0 FI SYSTEM DETAILS

Complete details of the FI system design and its rationale may be found in Martin Marietta report MCR-79-1411, Volumes I and II.

These volumes describe in detail all work performed in Tasks 1, 2, and 3 of Air Force contract F19628-77-C-0262.



*MISSION
of
Rome Air Development Center*

RADC plans and executes research, development, test and selected acquisition programs in support of Command, Control Communications and Intelligence (C³I) activities. Technical and engineering support within areas of technical competence is provided to ESD Program Offices (POs) and other ESD elements. The principal technical mission areas are communications, electromagnetic guidance and control, surveillance of ground and aerospace objects, intelligence data collection and handling, information system technology, ionospheric propagation, solid state sciences, microwave physics and electronic reliability, maintainability and compatibility.