

UNCLASSIFIED

AD NUMBER
ADB112326
NEW LIMITATION CHANGE
TO Approved for public release, distribution unlimited
FROM Distribution limited to U.S. Gov't. agencies and their contractors; Critical Technology; Oct 86. Other requests must be referred to Commander, Naval Air Development Center, Warminster, PA 18974-5000.
AUTHORITY
NAWC ltr., 24 May 96

THIS PAGE IS UNCLASSIFIED

DTIC FILE COPY

REPORT NO. NADC-87042-60

2

DOT/FAA/CT-86/39



CERTIFICATION TESTING METHODOLOGY FOR COMPOSITE STRUCTURE

Volume II—Methodology Development

R.S. Whitehead, H.P. Kan, R. Cordero, E.S. Saether

Northrop Corporation
Aircraft Division
One Northrop Avenue
Hawthorne, CA 90250

AD-B112 326

OCTOBER 1986

FINAL REPORT

Contract No. N62269-84-C-0243

DTIC
SELECTED
JUN 18 1987
S A D

*Distribution limited to U.S. Government agencies and
their contractors; Critical Technology. Other requests
for this document shall be referred to COMNAVAIRDEVGEN.*

Prepared for
NAVAL AIR DEVELOPMENT CENTER
Department of the Navy
Warminster, PA 18974-5000
and
Federal Aviation Administration Technical Center
U.S. Department of Transportation
Atlantic City, NJ 08405

87 6 17 025
87 6 16 038

NOTICES

REPORT NUMBERING SYSTEM - The numbering of technical project reports issued by the Naval Air Development Center is arranged for specific identification purposes. Each number consists of the Center acronym, the calendar year in which the number was assigned, the sequence number of the report within the specific calendar year, and the official 2-digit correspondence code of the Command Office or the Functional Department responsible for the report. For example: Report No. NADC-86015-70 indicates the fifteenth Center report for the year 1986 and prepared by the Systems and Software Technology Department. The numerical codes are as follows:

CODE	OFFICE OR DEPARTMENT
00	Commander, Naval Air Development Center
01	Technical Director, Naval Air Development Center
02	Comptroller
05	Computer Department
07	Planning Assessment Resources Department
10	Anti-Submarine Warfare Systems Department
20	Tactical Air Systems Department
30	Battle Force Systems Department
40	Communication & Navigation Technology Department
50	Mission Avionics Technology Department
60	Air Vehicle & Crew Systems Technology Department
70	Systems & Software Technology Department
80	Engineering Support Group

PRODUCT ENDORSEMENT - The discussion or instructions concerning commercial products herein do not constitute an endorsement by the Government nor do they convey or imply the license or right to use such products.

DISCLAIMER

The findings in this report are not to be construed as an official Federal Aviation Administration (FAA) position. In addition, the term "certification," as used in this report, does not in any way refer to the compliance process established in Title 14, Code of Federal Regulations.

AD-B113-386

REPORT DOCUMENTATION PAGE

1a. REPORT SECURITY CLASSIFICATION UNCLASSIFIED		1b. RESTRICTIVE MARKINGS	
2a. SECURITY CLASSIFICATION AUTHORITY		3. DISTRIBUTION/AVAILABILITY OF REPORT Distribution limited to U.S. Government Agencies and their contractors only; Critical Technology; October 1988: All other requests for this document must be referred to: COMNAVAIRDEVGEN	
2b. DECLASSIFICATION/DOWNGRADING SCHEDULE		4. PERFORMING ORGANIZATION REPORT NUMBER(S)	
6a. NAME OF PERFORMING ORGANIZATION Northrop Corporation Aircraft Division		6b. OFFICE SYMBOL (if applicable)	
6c. ADDRESS (City, State, and ZIP Code) One Northrope Avenue Hawthorne, CA 90250		7a. NAME OF MONITORING ORGANIZATION Naval Air Development Center	
8a. NAME OF FUNDING/SPONSORING ORGANIZATION Naval Air Development Center		8b. OFFICE SYMBOL (if applicable) 6043	
8c. ADDRESS (City, State, and ZIP Code) Warminster, PA 18974		9. PROCUREMENT INSTRUMENT IDENTIFICATION NUMBER Contract N62269-84-C-0243	
11. TITLE (Include Security Classification) Certification Testing Methodology for Composite Structures (U)		10. SOURCE OF FUNDING NUMBERS	
		PROGRAM ELEMENT NO.	PROJECT NO.
		TASK NO.	WORK UNIT ACCESSION NO.
12. PERSONAL AUTHOR(S) Whitehead, R.S., Kan, H.P., Cordero, R. and Saether, E.S.		14. DATE OF REPORT (Year, Month, Day) 1986, October	
13a. TYPE OF REPORT Final	13b. TIME COVERED FROM 3/84 TO 12/85	15. PAGE COUNT	
16. SUPPLEMENTARY NOTATION The findings in this report are not to be construed as an Official Federal Aviation Administration (FAA) position. In addition, the term "certification," as used in this report, does not in any way refer to the compliance process established in Title 14, Code of Federal Regulations.			
17. COSATI CODES		18. SUBJECT TERMS (Continue on reverse if necessary and identify by block number)	
FIELD	GROUP	Certification Aircraft Structures	
01	03	Composite Materials Fatigue	
11	04		
19. ABSTRACT (Continue on reverse if necessary and identify by block number)			
<p>This research developed a certification testing methodology for composite structures. The existing composite static strength and fatigue life data are analyzed statistically to determine the influence of test parameters on the scatter of composite data. Guidelines to use the composite data scatter in structural certification are recommended.</p> <p>Various approaches to composite structures certification are analytically evaluated. The approaches evaluated are: scatter factor approach, load enhancement factor approach, ultimate strength approach and change in spectrum approach. The capability, advantages and disadvantages of each approach to determine the minimum life and/or strength are fully discussed. (<i>Key work</i>)</p>			
20. DISTRIBUTION/AVAILABILITY OF ABSTRACT <input type="checkbox"/> UNCLASSIFIED/UNLIMITED <input checked="" type="checkbox"/> SAME AS RPT. <input type="checkbox"/> DTIC USERS		21. ABSTRACT SECURITY CLASSIFICATION UNCLASSIFIED	
22a. NAME OF RESPONSIBLE INDIVIDUAL E. KAUTZ		22b. TELEPHONE (Include Area Code) (215) 441-1561	22c. OFFICE SYMBOL 6043



19. Abstract

A methodology for certification testing of composite structures is developed and a detailed description of the methodology is presented. Test data interpretation methodology is also developed. The methodology is demonstrated on existing composite structures.

Based on the results of this investigation, composite structure certification testing procedure and requirements are recommended.

Volume I of this report discusses the scatter analysis methods and results of static strength and fatigue life data analysis. Details of the certification approach evaluation, methodology development and demonstrations are given in Volume II. Volume II also contains the recommended certification testing procedure.



Accession For	
NTIS GRA&I	<input type="checkbox"/>
DTIC TAB	<input checked="" type="checkbox"/>
Unannounced	<input type="checkbox"/>
Justification	
By _____	
Distribution/	
Availability Codes	
Dist	Avail and/or Special
0-2	

PREFACE

This report was prepared by the Northrop Corporation, Aircraft Division, Hawthorne, California, covering work performed under U.S. Navy Contract N62269-C-0243 between March 1984 and December 1985. The contract was administered by the Naval Air Development Center, Warminster, Pennsylvania. Mr. Ed Kautz was the Navy Project Engineer. Partial finding of this effort was provided by the Federal Aviation Administration Technical Center, Atlantic City International Airport, NJ. Mr. L. M. Neri acted as the FAA Technical Manager.

The work was performed in the Northrop's Strength and Life Assurance Research Department under the overall supervision of Dr. R. S. Whitehead. The following Northrop personnel were the major contributors to the program.

Program Manager	Dr. R. S. Whitehead
Principal Investigator	Dr. H. P. Kan
Data Analysis	R. Cordero
	E. Saether
Documentation	J. Gibo
	C. Gatewood
	R. Cordero

TABLE OF CONTENTS

<u>SECTION</u>		<u>PAGE</u>
1	INTRODUCTION AND BACKGROUND.....	1
2	CERTIFICATION APPROACH EVALUATION.....	11
2.1	Scatter Factor Approach.....	11
2.1.1	Static Strength Evaluation.....	13
2.1.2	Fatigue Life Evaluation.....	16
2.1.3	Assessment of the Navy Certification Approach.....	26
2.1.3.1	Static Strength.....	26
2.1.3.2	Fatigue Strength.....	35
2.1.4	Example Reliability Calculations.....	35
2.1.4.1	Static Strength Reliability.....	36
2.1.4.2	Fatigue Life Reliability....	37
2.2	Load Enhancement Factor Approach.....	41
2.3	Ultimate Strength Approach.....	53
2.4	Change in Spectrum Approach.....	75
2.5	Summary of Certification Approach Evaluation.....	84
3	METHODOLOGY DEVELOPMENT.....	87
3.1	Concept of Structural Response Variability (SRV).....	87
3.2	Structural Response Variability Data.....	98
3.2.1	Determination of Structural Response Variability.....	98
3.2.2	Structural Response Variability Analysis Results.....	102
3.3	Usage Variation.....	123

TABLE OF CONTENTS

<u>SECTION</u>	<u>PAGE</u>
4	METHODOLOGY DEMONSTRATION..... 133
4.1	Composite Wing/Fuselage Program Data Base... 133
4.2	Wing Component (WCC-1) Data Evaluation..... 139
4.2.1	WCC-1 Static Test Data Evaluation.... 139
4.2.2	WCC-1 Fatigue Test Data Evaluation... 147
4.2.2.1	Load Enhancement Factor Approach..... 147
4.2.2.2	Ultimate Strength Approach.. 149
4.2.2.3	Residual Strength Approach.. 153
4.3	Wing Specimens Test Data Evaluation Summary. 156
4.4	Fuselage Component FCC-1 Data Evaluation.... 161
4.4.1	FCC-1 Static Test Data Evaluation.... 164
4.4.2	FCC-1 Fatigue Test Data Evaluation... 164
4.5	Fuselage Specimen Test Data Evaluation..... 174
5	RECOMMENDED CERTIFICATION TESTING PROCEDURE..... 179
5.1	Testing Requirements..... 179
5.1.1	Design Allowables..... 179
5.1.1.1	Static Design Allowables.... 179
5.1.1.2	Fatigue Design Allowables... 186
5.1.2	Design Development Testing..... 190
5.1.2.1	Static Tests..... 194
5.1.2.2	Fatigue Tests..... 195
5.1.2.3	Mixed Composite/Metal Structures..... 198

TABLE OF CONTENTS

<u>SECTION</u>	<u>PAGE</u>
5.1.3 Full-Scale Testing.....	199
5.1.3.1 Full-Scale Static Test.....	199
5.1.3.2 Full-Scale Durability Test..	200
5.2 Test Result Interpretation.....	201
6 SUMMARY AND CONCLUSIONS.....	205
6.1 Summary.....	205
6.2 Conclusions.....	205
REFERENCES	207
APPENDIX COMPUTER PROGRAMS.....	209
A.1 Program "WEIBULL".....	209
A.2 Program "WEIBJNT".....	218
A.3 Program "LOAD".....	232
A.4 Program "ALLOW".....	236
A.5 Programs "BSRV" and "CSRV".....	241

LIST OF ILLUSTRATIONS

<u>FIGURE</u>		<u>PAGE</u>
1.	Differences Between Metals and Composites.....	2
2.	Comparison of Static Notch Sensitivity Between Composites and Metals.....	3
3.	Typical Fatigue Behavior of Graphite/Epoxy Composites.....	4
4.	Comparison of Metal and Composite Fatigue Behavior Under Spectrum Loading.....	6
5.	Influence of Weibull Shape Parameter on Demon- strated Reliability of Design Limit Load for Failure at Design Ultimate Load.....	14
6.	Influence of Mean Static Failure Load on Demonstrated Reliability at Design Limit Load....	15
7.	Influence of Sample Size on B-basis Static Strength.....	17
8.	Influence of Maximum Operating Load to Mean Static Failure Load Ratio on Static Strength Reliability.....	18
9.	Influence of Environmental Knockdown Factor on Static Strength Reliability.....	19
10.	Influence of Fatigue Life Shape Parameter on Reliability Demonstrated by a Two-Lifetime Fatigue Test.....	21
11.	Influence of Mean Test Lifetime on the Reli- ability Achieved at One Lifetime.....	22
12.	Influence of Sample Size on B-basis Fatigue Life to Mean Fatigue Life Ratio.....	23
13.	Influence of Fatigue Life Scatter on B-basis Fatigue Life to Mean Fatigue Life Ratio.....	24
14.	Influence of Required Fatigue Life to Mean Test Life Ratio on Fatigue Reliability.....	25
15.	F/A-18A and AV-8B Load-Strain Assessment Concept.	27
16.	Schematic of the Calculation of Design Allowable Strain Level (Reference 1).....	27

LIST OF ILLUSTRATIONS

<u>FIGURE</u>		<u>PAGE</u>
17.	Influence of Nonlinear Load-Strain Response on the F/A-18A and AV-8B Load-Strain Assessment Concept.....	30
18.	Material Selection Criterion.....	32
19.	Influence of Temperature and Moisture on Material Operational Limits.....	33
20.	Temperature Spectrum for Mach 2 Fighter Aircraft in Reference 5.....	39
21.	Load-Factor Temperature Relationship for Mach 2 Fighter Aircraft in Reference 5.....	40
22.	Schematic of Load Enhancement Factor Approach for Composites.....	43
23.	Influence of Residual Strength Scatter α_R on Load Enhancement Factor (One Lifetime Fatigue Test).....	47
24.	Influence of Residual Strength Scatter α_R on Load Enhancement Factor (Two Lifetime Fatigue Test)...	49
25.	Influence of Test Duration on B-Basis Load Enhancement Factors.....	50
26.	Influence of Test Duration on A-Basis Load Enhancement Factors.....	51
27.	Comparison of Load Enhancement Factors Calculated by the Sendeckyj Analysis with Theoretical Values.....	52
28.	Composite Fatigue Life Threshold Approach.....	54
29.	Influence of Loading Mode on the B-Basis to Mean Life Fatigue Threshold Ratio, σ_e^B/σ_e^M	56
30.	Influence of Loading Mode on the B-Basis to Mean Life Fatigue Threshold Ratio, σ_e^B/σ_e^M	58
31.	Distribution of B-Basis to Mean Fatigue Life Thresholds for Navy Data.....	59

LIST OF ILLUSTRATIONS

<u>FIGURE</u>		<u>PAGE</u>
32.	Distribution of B-Basis to Mean Fatigue Life Thresholds for Baseline Data.....	60
33.	Comparison of Navy and Baseline B-Basis to Mean- Fatigue Life Threshold Distributions.....	61
34.	Distribution of B-Basis to Mean Fatigue Life Thresholds for Combined Data.....	62
35.	Influence of Fatigue Loading Mode on Normalized Fatigue Threshold for Intermediate Load Transfer Specimens in Reference 16.....	64
36.	Influence of Fatigue Loading Mode on Normalized Fatigue Threshold for High Load Transfer Speci- mens in Reference 16.....	65
37.	Influence of Fatigue Loading Mode on Normalized Fatigue Threshold for Complex Specimens in Reference 16.....	66
38.	Influence of Fatigue Loading Mode on Normalized Fatigue Threshold for all Specimens in Reference 16.....	68
39.	Influence of Joint Geometry, Lay-up and Spectrum Type on Normalized Fatigue Thresholds.....	70
40.	Statistical Fatigue Threshold for Upper Wing Skin Spectrum Loading.....	72
41.	Influence of Spectrum Type on Static Overload Requirement for B-Basis Fatigue Reliability.....	74
42.	Schematic Summary of Mixed Structure Testing Problems (A. Someroff NAVAIR, October 1981).....	76
43.	Comparison of Composite and Metallic Fatigue Spectrum Fatigue Behavior for a Wing Spectrum....	77
44.	Influence of Spectrum Type on Predicted Composite and Metal Fatigue Life.....	78
45.	Comparison of F-18 Fatigue Spectra.....	79
46.	Influence of Overloads on Composite Fatigue Life for an F-18 Upper Wing Root Spectrum.....	80

LIST OF ILLUSTRATIONS

<u>FIGURE</u>		<u>PAGE</u>
47.	Influence of Spectrum Type and Overloads on Composite Fatigue Life.....	82
48.	Influence of Overloads on Composite and Metal Fatigue Life.....	83
49.	Equivalent Composite Load Enhancement Factors for an F-18 Upper Wing Spectrum.....	85
50.	Schematic of "Hot-Spot" Failure in Relation to the Scatter in Strength and Structural Response for a Static Test.....	88
51.	Influence of SRV on B-Basis Design Allowables, $\alpha_S=20.0$	91
52.	Influence of SRV on A-Basis Design Allowables, $\alpha_S=20.0$	92
53.	Influence of Static Strength Variability on the B-Basis Design Allowable at Mean and Modal SRV...	93
54.	Influence of Static Strength Variability on the A-Basis Design Allowable at Mean and Modal SRV...	94
55.	Influence of Structural Response Variability on the B-Basis Structural Reliability.....	96
56.	Influence of Structural Response Variability on the A-Basis Structural Reliability.....	97
57.	Building Block Approach for the Wing Structure in the Composite Wing/Fuselage Program (Reference 5).....	99
58.	Typical Applied Load Strain Response from a WS-1 Subcomponent Test (Reference 5).....	101
59.	WS-1 Lower Skin ETW Load-Strain Response.....	104
60.	WS-1 Upper Skin ETW Load-Strain Response.....	104
61.	WCC-1 Upper Skin Load-Strain Response at Wing Station 48 (Gage Number 25) for Load Case 130....	105
62.	WCC-1 Upper Skin Load-Strain Response at Wing Station 48 (Gage Number 30) for Load Case 130....	105

LIST OF ILLUSTRATIONS

<u>FIGURE</u>		<u>PAGE</u>
63.	WCC-1 Upper Skin Load-Strain Response at Wing Station 48 (Gage Number 32) for Load Case 130....	106
64.	WCC-1 Upper Skin Load-Strain Response at Wing Station 48 (Gage Number 40) for Load Case 130....	106
65.	Influence of Specimen Complexity Level on RTA Structural Response Variability.....	107
66.	Influence of Specimen Complexity Level on ETW Structural Response Variability.....	107
67.	Influence of Specimen Complexity Level on Combined RTA and ETW Structural Response Variability.....	108
68.	Influence of Environment on Structural Response Variability.....	108
69.	WCC-1 Design Ultimate Load Lower Skin Strain Distribution at Wing Station 43 for Load Case 130.....	110
70.	WCC-1 Design Ultimate Load Lower Skin Strain Distribution at Wing Station 85 for Load Case 130.....	110
71.	WCC-1 Design Ultimate Load Upper Skin Strain Distribution at Wing Station 48 for Load Case 130.....	111
72.	WCC-1 Load-Strain Response for Load Case 100.....	115
73.	WCC-1 Load-Strain Response for Load Case 110.....	116
74.	WCC-1 Load-Strain Response for Load Case 130.....	117
75.	WCC-1 Load-Strain Response for Load Case 102.....	118
76.	WCC-1 Load-Strain Response for Load Case 201.....	119
77.	Influence of Loading Case on Structural Response Variability.....	120
78.	Distribution of Structural Response Variability for Combined RTD + ETW Load-Strain Data.....	122
79.	Comparison of Usage Severity Change for Composites and Metals.....	124

LIST OF ILLUSTRATIONS

<u>FIGURE</u>		<u>PAGE</u>
80.	Methodology for Incorporating Usage Variation into Fatigue Life Reliability Calculations.....	126
81.	Influence of Usage Variation on Fatigue Reliability ($\sigma_a/\sigma_u=0.8$).....	128
82.	Change of Reliability with Usage Variation.....	129
83.	Effects of Usage Variation on the B-Basis Life...	131
84.	Effect of Usage Variation on the B-Basis Fatigue Life Factor.....	132
85.	Building Block Approach for the Fuselage Structure in Reference 5.....	136
86.	Fatigue Test Schemes Used in Reference 5.....	138
87.	Wing Component with Load Introduction Structure (Reference 5).....	140
88.	WCC-1 Test Set-up (Reference 5).....	141
89.	WCC-1 Static Strength Reliability Distributions..	145
90.	WCC-1 Fatigue Reliability Distribution Determined by the Load Enhancement Factor Approach.....	150
91.	WCC-1 Fatigue Reliability Distribution Determined by the Ultimate Strength Approach.....	154
92.	WCC-1 Fatigue Reliability Distribution Determined by the Residual Strength Approach.....	157
93.	Fuselage Component (FCC-1).....	162
94.	FCC-1 Loading.....	163
95.	FCC-1 Static Strength Reliability Distributions..	167
96.	FCC-1 Fatigue Reliability--Load Enhancement Factor Approach.....	171
97.	FCC-1 Fatigue Reliability--Ultimate Strength Approach.....	172

LIST OF ILLUSTRATIONS

<u>FIGURE</u>		<u>PAGE</u>
98.	Determination of Design Allowables Over a Range of Temperature.....	185
99.	Influence of SRV on the A- and B-Basis Knockdown Factor.....	187
100	Fatigue Allowable Approaches.....	189

LIST OF TABLES

<u>TABLE</u>		<u>PAGE</u>
1	Summary of the Statistical Analysis of the B-Basis to Mean Fatigue Life Threshold Ratio Values.....	63
2	Influence of Test Variables on Normalized Fatigue Thresholds Under Spectrum Loading.....	69
3	Static Failure Load Requirements for No Fatigue Test of a (48/48/4) Laminate in a RTD Environment.....	73
4	Influence of SRV on Knockdown Factors, n = 1.....	95
5	Summary of Strain Gage Data Available from the Composite Wing/Fuselage Program (Reference 5)....	100
6	Structural Response Variability Analysis Results.....	103
7	Comparison of WCC-1 Load-Strain and Strain Distribution Structural Response Variability.....	112
8	Summary of WCC-1 Ultimate Static Load Cases.....	113
9	Wing Component (WCC-1) Tests in Reference 5.....	114
10	Influence of Loading Case on Load-Strain Structural Response Variability.....	114
11	Summary of Wing Test Matrix from Reference 5.....	135
12	Summary of Fuselage Test Matrix from Reference 5.	137
13	Summary of Wing Component (WCC-1) Static Design Ultimate Loads.....	142
14	Summary of Wing Component (WCC-1) Failure Loads..	143
15	Summary of WCC-1 Static Strength Reliability and Allowable Operating Loads.....	146
16	Summary of WCC-1 Fatigue Test Loads.....	148
17	Summary of WCC-1 RTA One Lifetime Fatigue Reliability.....	151
18	Summary of WCC-1 Environmental One Lifetime Fatigue Reliability.....	152

LIST OF TABLES

<u>TABLE</u>		<u>PAGE</u>
19	Summary of Static Strength Reliabilities and Allowable Operating Loads for Wing Test Specimens.....	158
20	Summary of One Lifetime Fatigue Reliabilities for Wing Test Specimens.....	160
21	Summary of Fuselage Component (FCC-1) Static Ultimate Design Loads.....	165
22	Summary of FCC-1 Failure Loads.....	166
23	Summary of FCC-1 Static Reliability.....	168
24	Summary of FCC-1 Fatigue Loads.....	169
25	Summary of FCC-1 RTA Fatigue Reliability at One Lifetime.....	170
26	Summary of FCC-1 Environmental Fatigue Reliability at One Lifetime.....	173
27	Summary of Static Strength Reliabilities and Allowable Operating Loads for Fuselage Test Specimens.....	175
28	Summary of One Lifetime Fatigue Reliabilities for Fuselage Test Specimens.....	177
29	Design Allowable to Mean Strength Ratio for the Recommended Sample Size.....	181
30	Lamina Static Strength Allowable Test Matrix.....	183
31	Laminate Static Strength Allowable Test Matrix...	184
32	Recommended Fatigue Allowable Test Matrix.....	191
33	Typical Load Factors.....	192
A-1	Values of $\chi^2(2n)/2n$ at $F=0.95$	242
A-2	Values of $\Gamma(1 + 1/\alpha)$	243
A-3	Relation Between Weibull Shape Parameter (α) and Coefficient of Variation (CV).....	244

LIST OF ABBREVIATIONS

RTD	Room Temperature Dry
RTW	Room Temperature Wet
ETW	Elevated Temperature Wet
(x/y/z)	(%0°/%±45°/%90°)
NO L/T	No Load Transfer Specimen
INT L/T	Intermediate Load Transfer Specimen
HIGH L/T	High Load Transfer Specimen
COMPLEX	Complex Specimen
C.V.	Coefficient of Variation
DLL	Design Limit Load
DUL	Design Ultimate Load
SRV	Structural Response Variability
MSL	Maximum Spectrum Load
MLE	Maximum Likelihood Estimates
MOL	Material Operating Limit

LIST OF SYMBOLS

R	Reliability also used as stress ratio (minimum stress/maximum stress)
\bar{x}	Sample mean
n	Sample size
$\chi^2_{\gamma}(2n)$	Chi-square distribution with 2n degrees-of-freedom at γ percentage point
α	Weibull shape parameter
$\hat{\alpha}$	MLE of Weibull shape parameter
β	Weibull scale parameter
$\hat{\beta}$	MLE of Weibull scale parameter
β	95% confident Weibull scale parameter
p	Probability of survival
N_A, N_B	A- and B-basis allowables
X	Required load or life
k	Environmental knockdown factor
$\epsilon^{150\%}$	Highest measured strain at 150% DLL
E	
ϵ^E	
ϵ^D	Design allowable strain in worse case environmental
ϵ^{RT}	
ϵ^D	Design allowable strain under room temperature ambient conditions
P_{FP}	Predicted room temperature ambient failure load
P_{FR}	Required room temperature ambient failure load
σ_e^M	Mean equivalent static strength from the Sendeckyj analysis
σ_e^B	B-Basis equivalent static strength from the Sendeckyj analysis
N	Test duration
F	Load enhancement factor
σ	Stress level
$\Gamma(X)$	Gamma functions

Subscripts	S	Static strength
	L	Fatigue life
	R	Residual strength
	F	Failure
	TH	Threshold

Superscripts	c	composite
	m	metal
	B	B-Basis
	M	mean

SECTION 1INTRODUCTION AND BACKGROUND

The application of composite materials to primary aircraft structures requires proven certification procedures to demonstrate their structural integrity. The development of certification procedures for primary composite structures must recognize the inherent differences between metals and composites. These differences are summarized in Figure 1. Composite load-strain response is different from metals in that it is essentially linear to failure. Because of their linear elastic behavior, composites are extremely statically notch sensitive to stress concentrations such as fastener holes. Figure 2 presents typical data which show that composites are statically notch sensitive under both tension and compression loading. For both loading modes, notch sensitivity increases as hole diameter increases. By contrast, the static holed strength of metals is essentially notch insensitive and follows the net section strength reduction line.

Metallic materials are extremely fatigue sensitive to stress concentrations, which are the primary source of fatigue cracking in aircraft structures. In contrast, composites are almost fatigue insensitive to stress concentrations such as fastener holes. Figure 3 presents typical data which show the influence of loaded and unloaded fastener holes on composite fatigue life. It can be seen that compression static strength is very sensitive to the various fastener hole geometries. However, the maximum compression fatigue strain required for a life of 10^7 cycles at an R-ratio of -1.7 is approximately constant at 4000 $\mu\text{in/in}$ for all specimen geometries. These data show that, at low cycle lives, fatigue behavior is controlled by the static strength, while at high cycle lives fatigue behavior is controlled by the net section stress level.

CONDITION	COMPOSITE BEHAVIOR RELATIVE TO METALS
LOAD-STRAIN RELATIONSHIP	MORE LINEAR STRAIN TO FAILURE
NOTCH SENSITIVITY	STATIC
	GREATER SENSITIVITY
FATIGUE	LESS SENSITIVITY
TRANSVERSE PROPERTIES	WEAKER
MECHANICAL PROPERTIES VARIABILITY	HIGHER
SENSITIVITY TO AIRCRAFT HYGROTHERMAL ENVIRONMENT	GREATER
DAMAGE GROWTH MECHANISM	IN-PLANE DELAMINATION INSTEAD OF THROUGH- THICKNESS CRACKS

FIGURE 1 . DIFFERENCES BETWEEN METALS AND COMPOSITES.

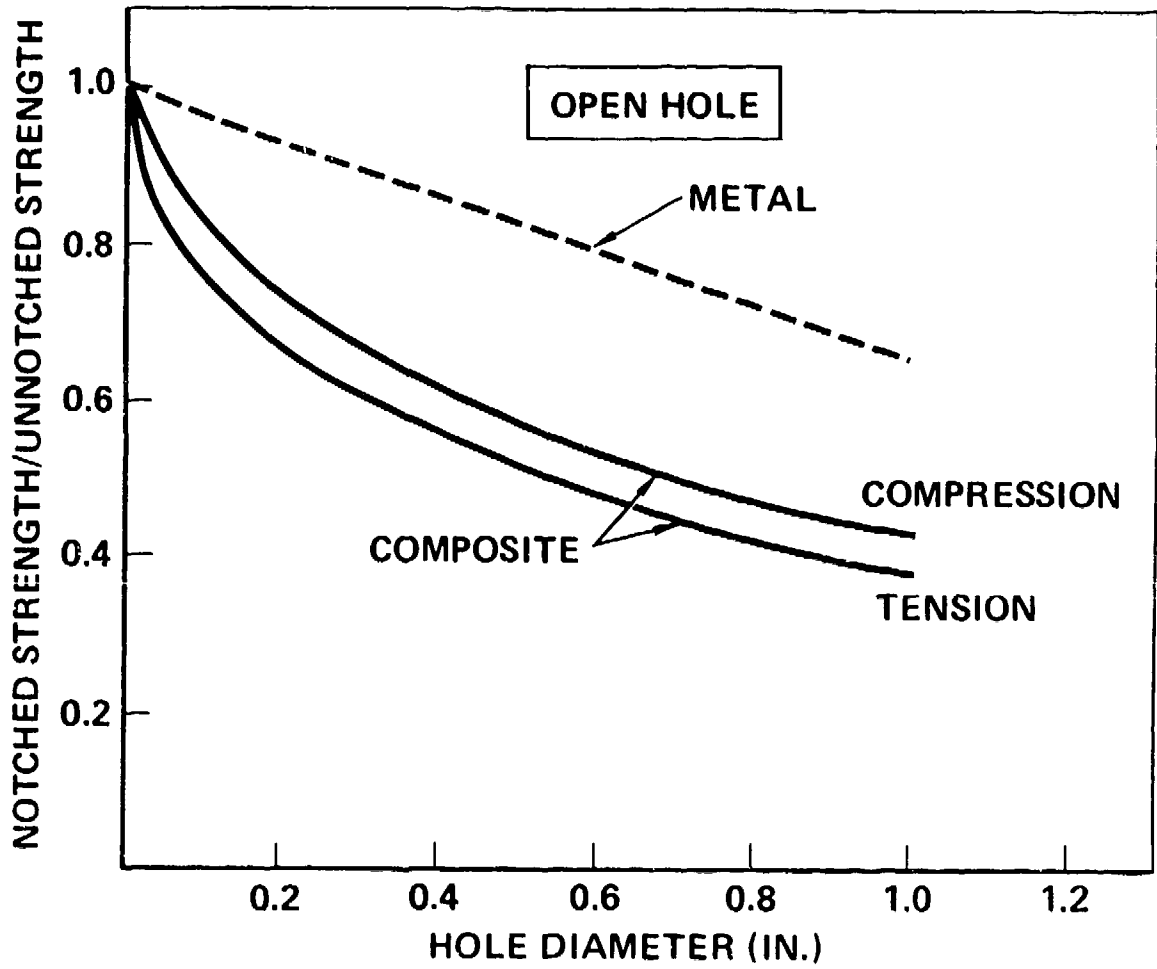

FIGURE 2. COMPARISON OF STATIC NOTCH SENSITIVITY BETWEEN COMPOSITES AND METALS.

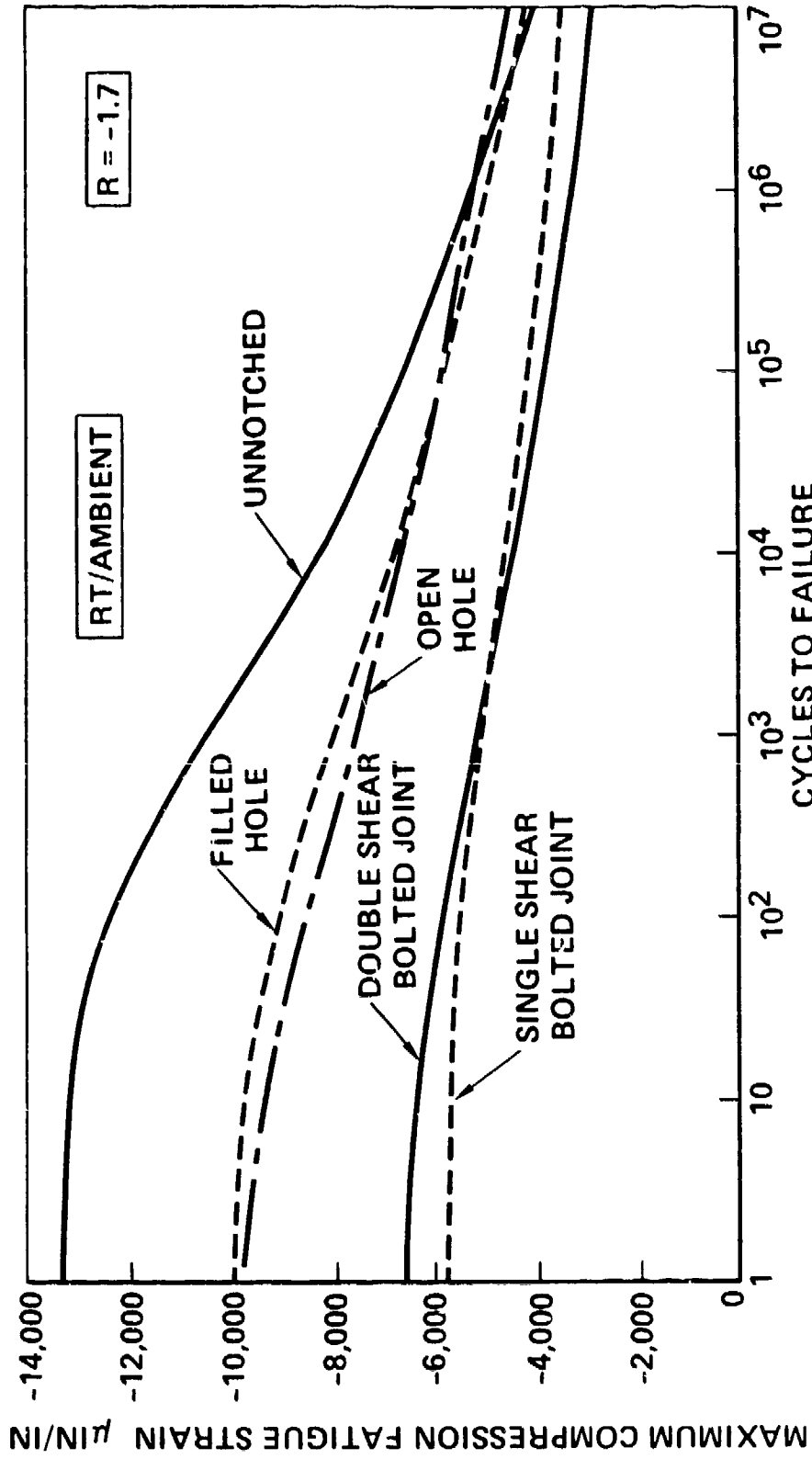

FIGURE 3. TYPICAL FATIGUE BEHAVIOR OF GRAPHITE/EPOXY COMPOSITES.

Figure 4 presents a comparison of metal and composite fatigue behavior under fighter aircraft wing spectrum loading. The comparison is made for an unloaded fastener hole specimen with a Young's Modulus of approximately 10,000 ksi. The data are plotted for each material's most sensitive fatigue loading mode, which is tension dominated (lower wing skin) for metals and compression dominated (upper wing skin) for composites. Figure 4 shows that composite fatigue properties are markedly superior to metal fatigue properties.

The transverse properties of metallic and composite structures also differ significantly. Because they are isotropic, metallic transverse (thru-thickness) properties are similar to their in-plane properties. However, since composites are laminates manufactured from individual plies, their transverse out-of-plane properties are controlled by interlaminar strength which is considerably weaker than in-plane strength. Typical room temperature/ambient interlaminar strengths for composites are 12 ksi for interlaminar shear and 3 ksi for interlaminar tension. These are low compared to an unnotched in-plane strength of 75 ksi for a typical wing skin laminate. Because of their anisotropic heterogeneous characteristics, composites exhibit significantly higher scatter than metals in both static and fatigue properties. This variability must be accounted for in the design and certification of composites structures.

Composites, which exhibit matrix controlled failure modes (e.g., compression), are sensitive to the aircraft hygrothermal environment. In particular, the effects of temperature and moisture have a synergistic effect. Therefore, the strength degradation of composites in hot/wet environments controls their maximum service temperature application.

Fatigue damage growth mechanisms differ considerably between metals and composites. In metals, fatigue cracks initiate at stress concentrations and generally grow to through-the-thickness cracks under tension dominated loading. In composites, it has been demonstrated that the most common damage growth mechanism is interlaminar separation, known as

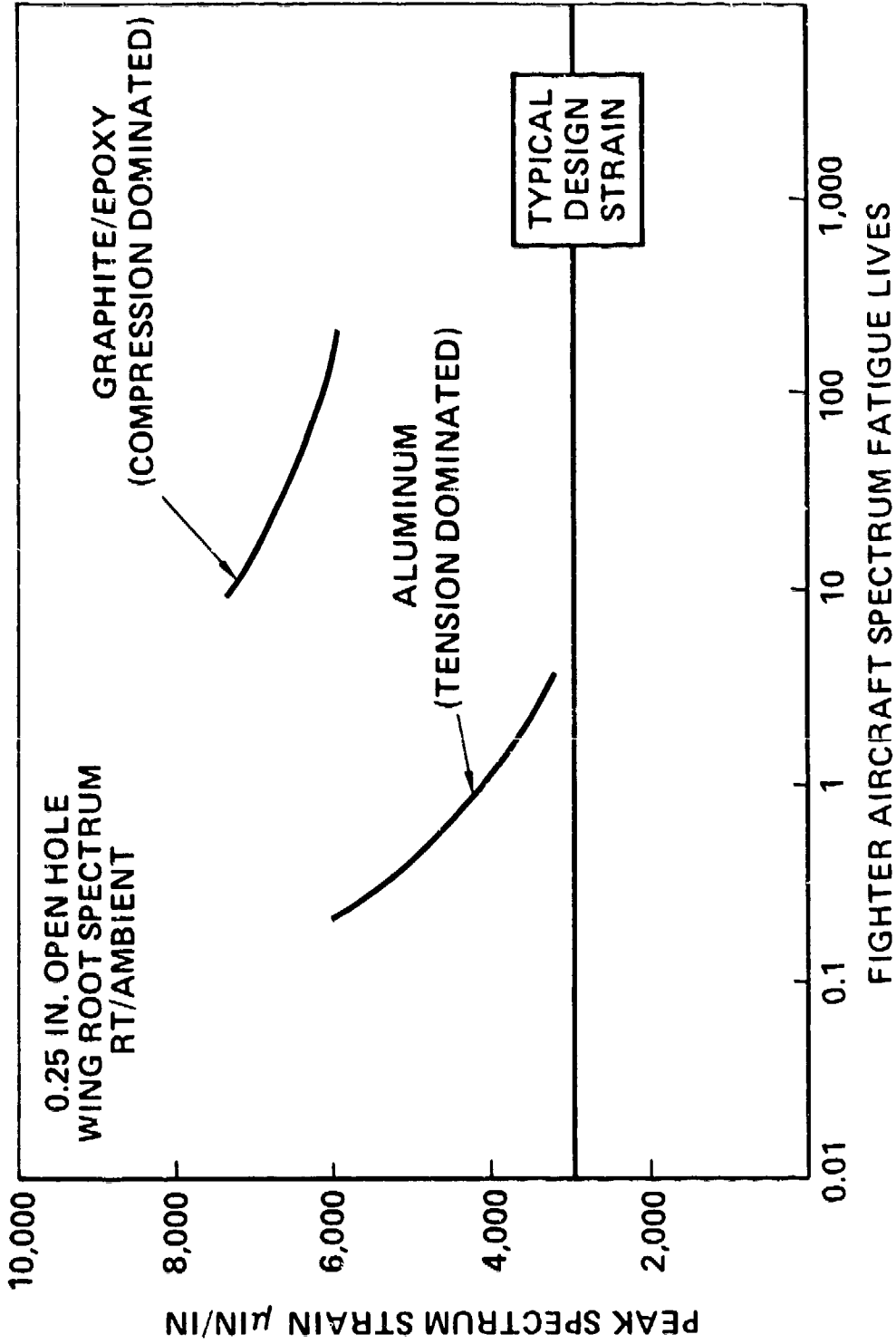

FIGURE 4. COMPARISON OF METAL AND COMPOSITE FATIGUE BEHAVIOR UNDER SPECTRUM LOADING.

delamination. Therefore, damage growth is an in-plane phenomenon. Prior to delamination growth, matrix cracking and fiber breakage usually occurs. The analogy with metals is that the latter would correspond to crack initiation, while the former would correspond to crack growth. Because delamination growth is the dominant growth mechanism in composites, they are most sensitive to compression dominated fatigue loading. A second composite fatigue failure mode has been observed in fastener holes subject to high bearing stresses. Fatigue failure can occur by hole wearout rather than delamination induced laminate failure. In this failure mode, the hole gradually elongates leading to a bearing failure.

The special properties of composites (fatigue notch insensitivity, weak transverse properties, matrix dominated failures, high failure variability, hygrothermal sensitivity and delamination fatigue growth mechanism) must be addressed in structural design and certification. It is emphasized that these properties do not negate the weight efficiency of composite structures, just that different parameters (from metals) are important in composite design and certification.

Current practice is to carry out an extensive design development test effort to:

1. Establish environmental and scatter knockdown for Strength critical failure modes, and
2. Validate critical design features.

These tests are conducted at the coupon, element and subcomponent levels. Following these tests, certification culminates in room temperature ambient full-scale static and fatigue tests. Usually, only one article is available for each test.

In order to have confidence in the certification compliance of full scale tests, it is imperative to be able to quantitatively interpret the test data generated. This is achieved by using the design development data not only in their traditional role in design development but also in the interpretation of full-scale test data.

Current certification practices do not provide an overall testing methodology for the planning and quantitative interpretation of design development and full-scale test data.

The objective of this program is to develop a certification testing methodology for composite aircraft structures. Specifically, the methodology will account for the effects on strength, life, and the scatter in strength and life of variation in structural configuration and complexity, stress or strain level, mixed composite-metal structure and fatigue spectrum shape. Test requirements and procedures for interpreting test results will be defined for the certification of future composite aircraft structure.

The program is composed of four tasks:

- TASK I - SCATTER ANALYSIS
- TASK II - CERTIFICATION APPROACH DEVELOPMENT/EVALUATION
- TASK III - METHODOLOGY DEVELOPMENT
- TASK IV - METHODOLOGY DEMONSTRATION

During Task I, existing composite static strength and fatigue life data were analyzed statistically to determine the influence of different test parameters on the scatter of composite data. The test variables included were: laminate lay-up, specimen type, loading mode, failure mode and test environment for both the static and fatigue data; in addition, stress level, stress ratio, spectrum variation and spectrum shape are investigated for fatigue data. The effects of each variable on static strength and fatigue life data scatter were established by performing statistical tests of significance. As a result of this task, guidelines to use the composite data scatter in structural certification will be recommended and these guidelines will be applied in the subsequent tasks of the program.

In Task II, various approaches to composite structure certification were analytically evaluated. The approaches evaluated were:

1. Scatter factor approach
2. Load enhancement factor approach
3. Ultimate strength approach
4. Change in spectrum approach

The capability, advantages and disadvantages of each approach to determine minimum (B-basis) and mean life and/or strength were fully evaluated. Effects of these approaches on the certification procedure of composite-metal mixed structure were also investigated. The conclusions of this evaluation will then be used in the methodology development.

A methodology for certification testing of composite structures was developed in Task III. The methodology was based on the results of the evaluation in Task II and the scatter analysis in Task I. The number and types of tests required at each level (coupon, element, subcomponent, component, and full-scale) of testing were defined. Test data interpretation methodology was also developed. As part of this task, a detailed description of the development methodology will be presented. This description will include detailed instructions for application and utilization of the methodology within the overall developmental process to satisfy design service life requirements for aircraft utilizing composite structures. The description will also include application of the methodology in an aircraft design/development program and determine the effects on service life resulting from usage change of an aircraft after its introduction into the fleet.

In Task IV, the methodology was demonstrated on an existing composite structure. The full-scale wing and fuselage component from the Composite Wing/Fuselage Program (Reference 1) were selected for this demonstration purpose. The results of the tests that have been performed on these demonstration articles were reevaluated using the methodology developed in Task III.

The scatter analysis methods and results of static strength and fatigue life data analysis are discussed in Volume

I. Details of Task II - Certification Approval Development/Evaluation. Task III - Methodology Development and Task IV - Methodology Demonstration are given in Volume II. Recommendations and certification testing requirements are also documented in Volume II. Computer programs to evaluate structure reliability are appended to Volume II.

SECTION 2
CERTIFICATION APPROACH EVALUATION

During Task II of the program detailed evaluation of various certification approaches was conducted. The approaches evaluated were:

1. Scatter factor approach,
2. Load enhancement factor approach,
3. Ultimate strength approach,
4. Change in spectrum approach.

Details of this evaluation are discussed in the following paragraphs. In the evaluation, unless specified otherwise, the modal Weibull shape parameters are used. That is $\alpha = 20.0$ for static strength and $\alpha = 1.25$ for fatigue life.

2.1 Scatter Factor Approach

Current Navy certification procedures for composite structures are based on the Scatter Factor Approach. The key elements in the full-scale test requirements are based on experience with metal structures. These are: static tests to a minimum of 150 percent design limit load (DLL) and fatigue tests with a severe load spectrum to a minimum of two lifetimes.

The reliability obtained by using these factors can be determined directly from the Weibull distribution function when the scatter parameter (α) is known. Then the reliability at 100 percent DLL or at 1.0 lifetime with γ level of confidence is given by

$$R = \exp \left\{ - \frac{\chi^2_{\gamma}(2n)}{2n} \left[\frac{\Gamma\left(\frac{\alpha+1}{\alpha}\right)}{\bar{x}} \right]^{\alpha} \right\} \quad (1)$$

Equation (1) can also be used to interpret static and fatigue test data. In these cases the value of \bar{x} is taken as the average static strength or fatigue life obtained from test.

The ratio of the B-basis static strength (fatigue life) to the mean failure load (fatigue life) is obtained by letting $R = 0.9$ in equation (1), which can be written as:

$$\frac{\sqrt{N_B}}{\bar{x}} = \frac{1}{\Gamma\left(\frac{\alpha+1}{\alpha}\right)} \left[\frac{-\ln(0.9)}{\chi_{\gamma}^2(2n)/2n} \right]^{1/\alpha} \quad (2)$$

The A-Basis strength or life factor is obtained simply replacing 0.9 by 0.99 in the above equation.

The influence of changes in load and/or life requirements on the reliability of an aircraft structure can be assessed after the design phase of the structure. This reliability can be computed from the mean test data for static strength or fatigue life. The γ level of confidence reliability is given by

$$R = \exp \left\{ - \left[\frac{\bar{x}}{\bar{x}} \Gamma\left(\frac{\alpha+1}{\alpha}\right) \right]^{\alpha} \cdot \frac{\chi_{\gamma}^2(2n)}{2n} \right\} \quad (3)$$

An environmental knockdown factor is applied in order to provide increased reliability from an ambient full-scale test on an environmentally critical structure. The environmental knockdown factor, k , is applied based on the assumption that the static strength Weibull shape parameter is not significantly affected by the test environments. This assumption is substantiated by the results of Task I data analysis. From this assumption, the γ level confidence reliability can be written as

$$R = \exp \left\{ - \left[\left(\frac{k\bar{x}}{\bar{x}} \Gamma\left(\frac{\alpha+1}{\alpha}\right) \right)^{\alpha} \cdot \frac{\chi_{\gamma}^2(2n)}{2n} \right] \right\} \quad (4)$$

2.1.1 Static Strength Evaluation

The static factor of 1.5 times limit load is used to safely account for unintentional deviations from service load and scatter in the static strength of a fleet of airframe structures. The degree of safety provided for metallic structures by the 1.5 factor can be calculated accurately, since the scatter in full-scale tests is known. However, there is insufficient data to establish composite full-scale test data scatter.

To evaluate the reliability of a structure at DLL using a 1.5 static factor approach, the value of \bar{x} in equation (1) is taken as 1.5. That is assuming the mean static failure load is at 1.5 DLL, or at DUL. It is seen from equation (1) that the reliability depends on the sample size, n , and the Weibull shape parameter α .

Figure 5 shows the 95 percent confidence reliability at DLL as a function of the static strength shape parameter (α). The reliability in this figure is computed assuming structural failure at 150 percent of DLL, or at DUL. As can be seen from the figure, at the modal value of $\alpha = 20.0$, the 95 percent confidence reliabilities are very high for all sample sizes, and far exceed the B-basis allowables. This indicates that the static factor of 1.5 times limit load provides a very high degree of safety. However, the reliability thus obtained does not account for unintentional deviations from service load, non-ambient service environments and structural response variability. The effects of these factors need to be investigated in order to fully evaluate the degree of safety provided by the 1.5 static factor.

Figure 6 presents the 95 percent reliability at DLL as a function of the mean static failure load (equation (1)). The figure shows that for a single article static test ($n = 1$) the B-basis reliability at the DLL can be achieved if the structure failure occurs at 115 percent of DLL. The same reliability can be achieved if the mean static failure load is 111 percent of DL for a sample size of 20. This level of reliability is again determined only by considering the scatter in static strength.

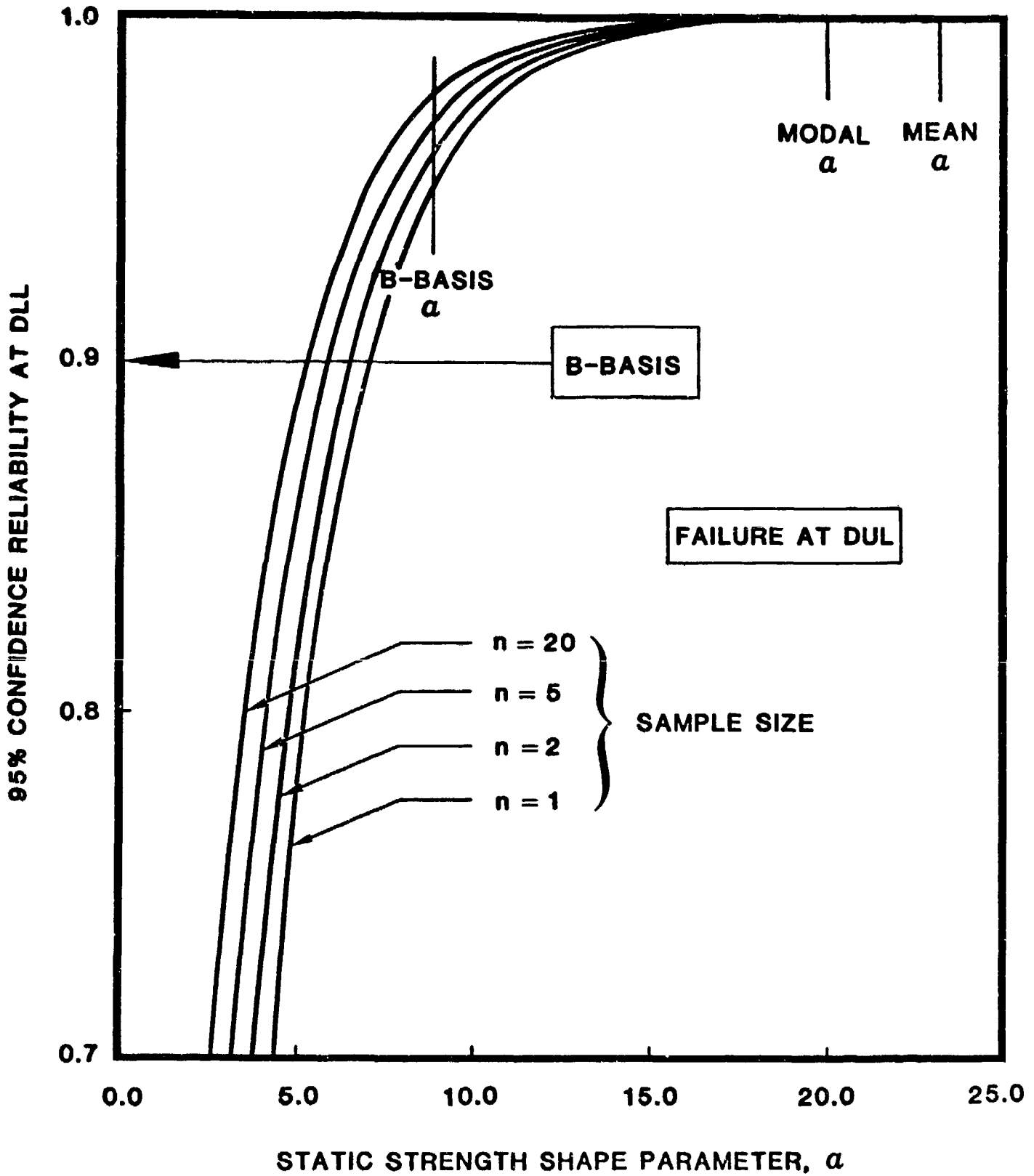

FIGURE 5. INFLUENCE OF WEIBULL SHAPE PARAMETER ON DEMONSTRATED RELIABILITY OF DESIGN LIMIT LOAD FOR FAILURE AT DESIGN ULTIMATE LOAD.

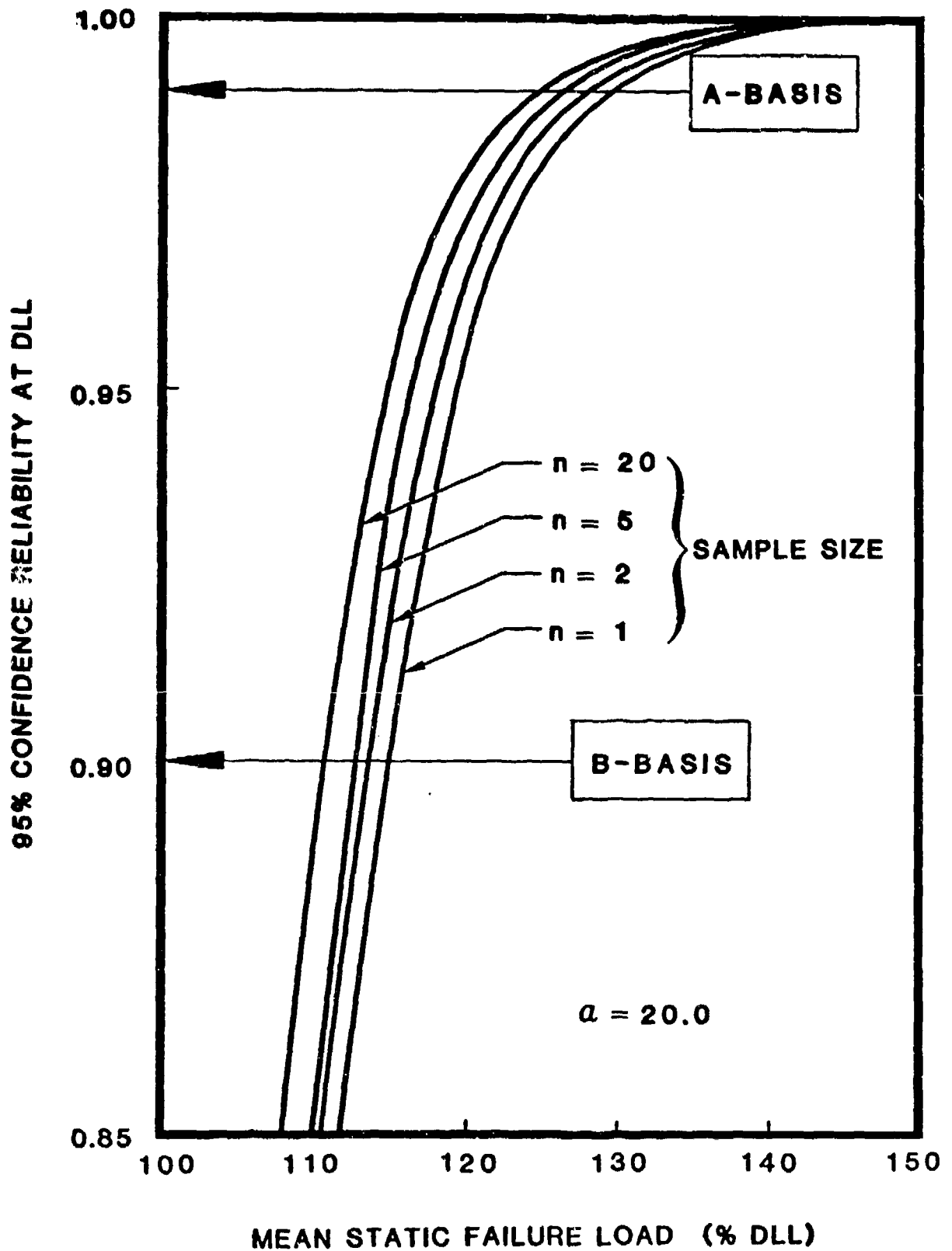

FIGURE 6. INFLUENCE OF MEAN STATIC FAILURE LOAD ON DEMONSTRATED RELIABILITY AT DESIGN LIMIT LOAD.

The influence of sample size on the B-basis static strength to the mean failure load ratio ($\sqrt{N_B/\bar{x}}$) is determined using Equation (2) and shown in Figure 7. This relation is shown for the mean (23.2), modal (20.0) and B-basis (8.8) values of α . As can be seen in the figure, the B-basis to mean failure ratio increases with sample size. For $\alpha=20.0$ (modal value), the value of $\sqrt{N_B/\bar{x}}$ only slightly increase when the sample size is larger than five.

The maximum operating load for a structure can be determined from the actual test results and a desired level of reliability (Equation (3)). This information is plotted in Figure 8. The figure shows the reliability for $\alpha = 20.0$. For B-basis reliability, the maximum load of the structure should not exceed 0.87 of the static test failure load for a sample size of one. Similarly, for A-basis reliability, the maximum load should remain below 0.77 of the failure load.

The effects of environmental knockdown factor on the resulting reliability is shown in Figure 9 (Equation (4)). The figure shows the reliability at different maximum operating load to mean static failure load ratios (X/\bar{x}). For a knockdown factor (k) of 1.1 with $n = 1$, the B-basis reliability maximum operation load is 0.79 of the failure load and the A-basis requires operating below 0.70 of the failure load. These values compare with 0.87 for B-basis and 0.77 for A-basis when no knockdown factor is applied. At $k = 1.5$ these values become 0.58 and 0.52 for B- and A-basis, respectively.

2.1.2 Fatigue Life Evaluation

The use of a fatigue scatter factor of 2-4 for metallic structures has historically been related to a reliability of approximately 699 in 700. Use of the scatter factors for composites cannot be justified because (from the analysis shown in Volume I), the Weibull shape parameter for composite fatigue life is extremely low (large scatter). The reliability of a two-lifetime test is approximately 1 in 4.

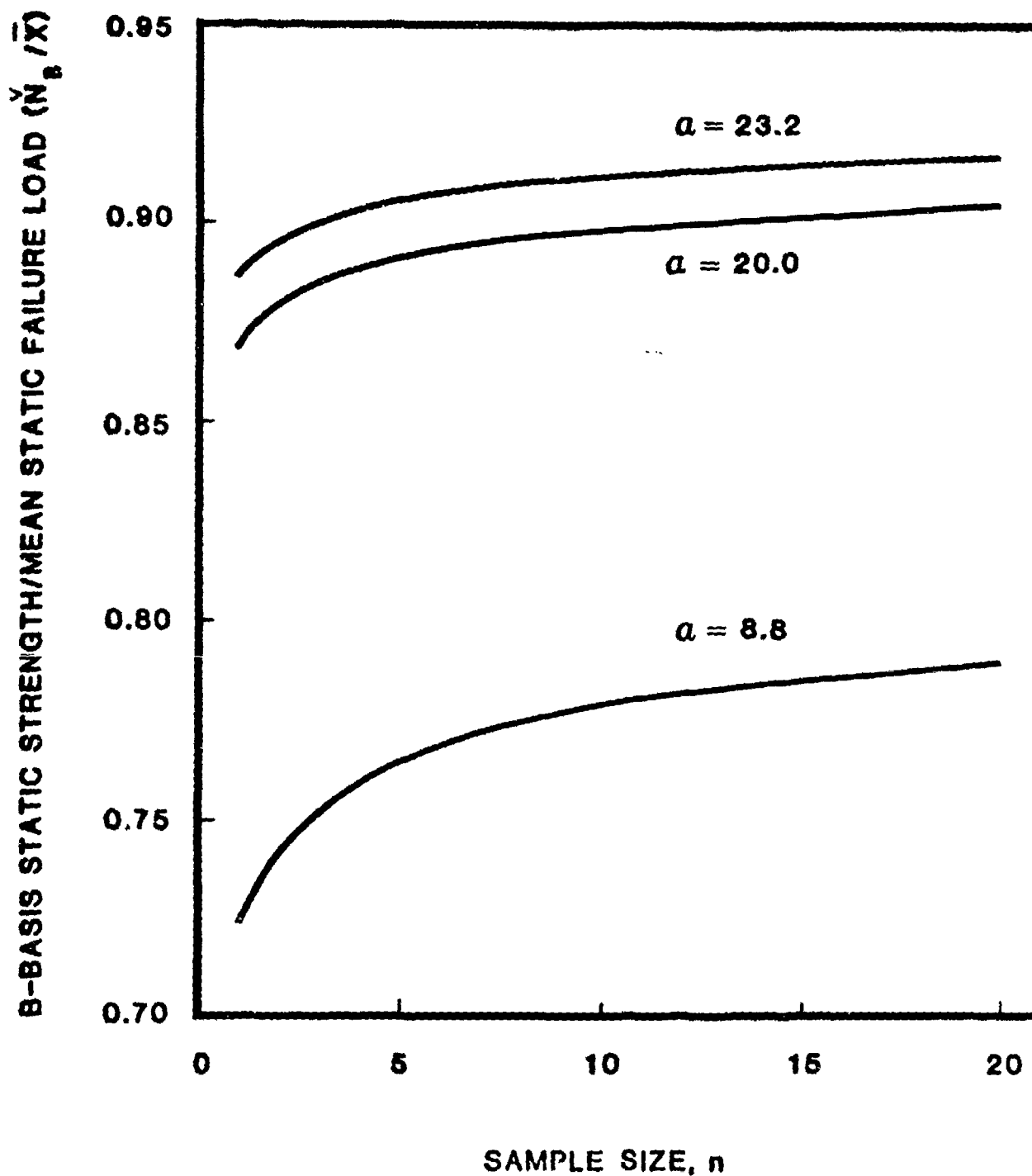

FIGURE 7. INFLUENCE OF SAMPLE SIZE ON B-BASIS STATIC STRENGTH.

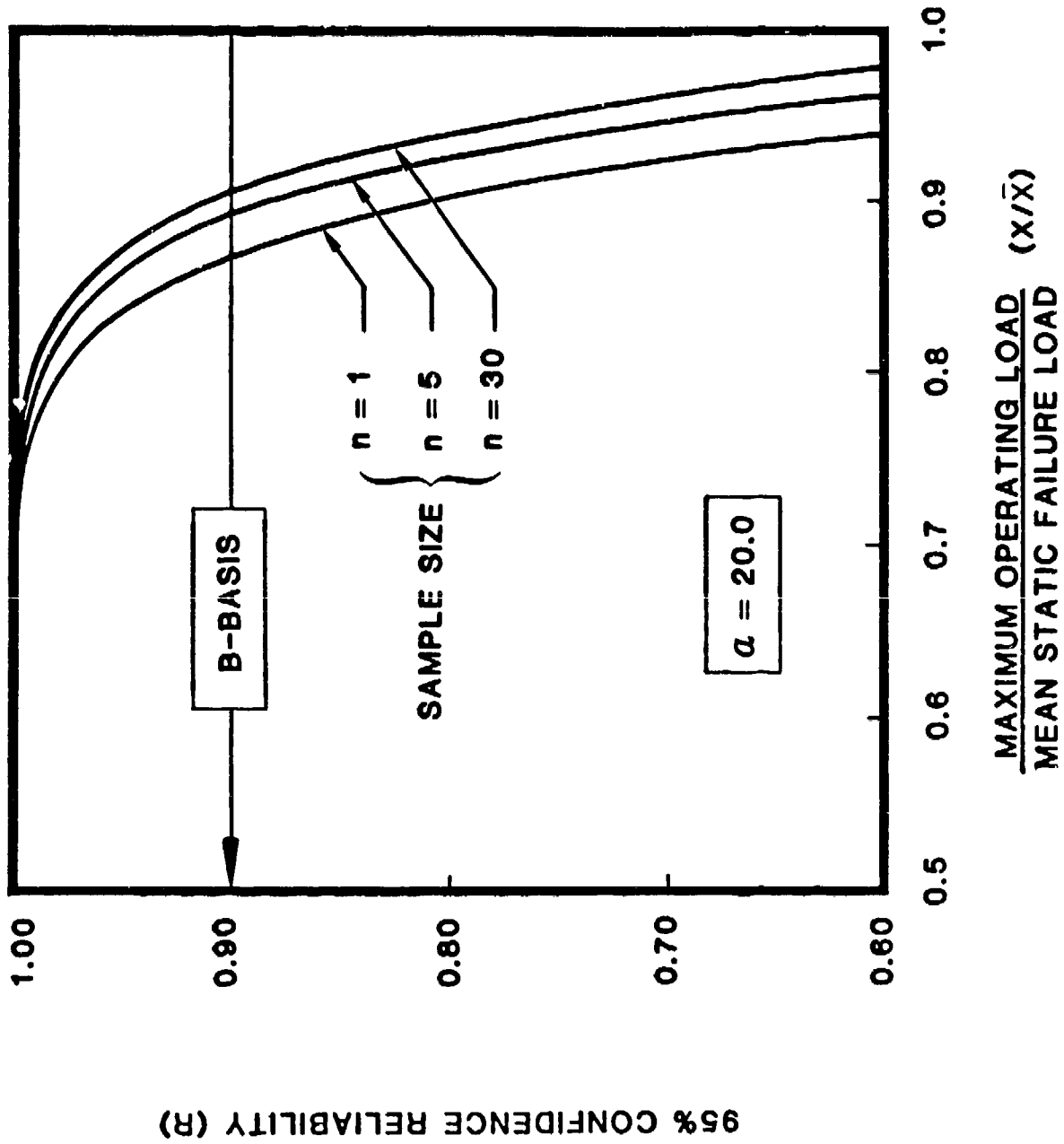

FIGURE 8. INFLUENCE OF MAXIMUM OPERATING LOAD TO MEAN STATIC FAILURE LOAD RATIO ON STATIC STRENGTH RELIABILITY.

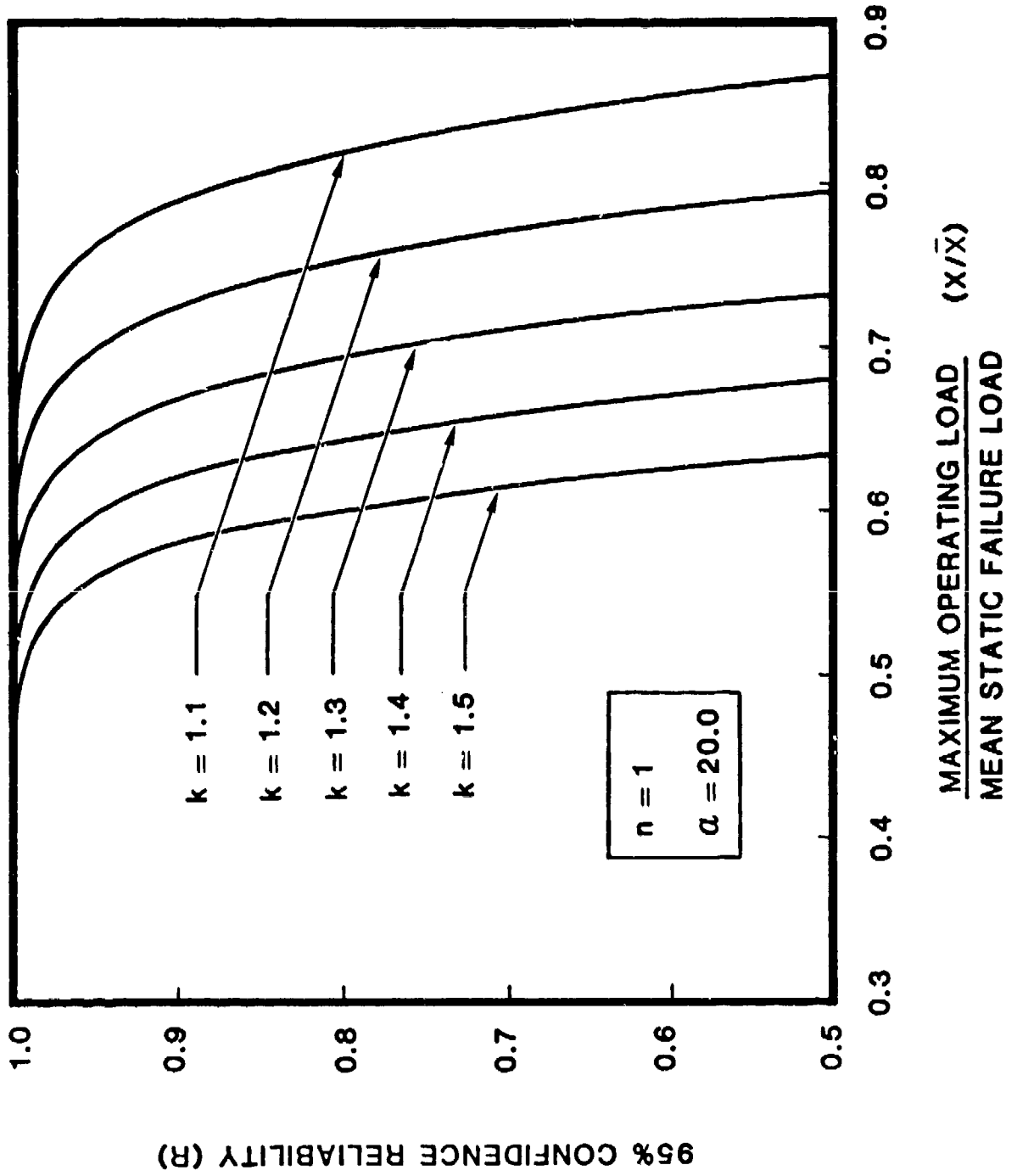

FIGURE 9. INFLUENCE OF ENVIRONMENTAL KNOCKDOWN FACTOR ON STATIC STRENGTH RELIABILITY.

The reliability of a two-lifetime fatigue test can be computed by letting $\bar{x} = 2.0$ in equation (1). The values of reliability are plotted as a function of the fatigue life shape parameter for different sample sizes in Figure 10. As can be seen from this figure, the two-lifetime fatigue test provides very low reliability for α 's commonly found for composites ($\alpha_{\text{mean}} = 2.17$ and $\alpha_{\text{modal}} = 1.25$). At the modal value of α , the reliability for sample size up to 10 is between 0.32 and 0.55 and is far below the B-basis allowable ($R = 0.90$). This indicates that a two-lifetime fatigue test does not provide the required level of reliability for composite structures. This conclusion is conservative for a two-lifetime fatigue test with no failure, since there is an unknown additional reliability associated with the assumption of failure at two lifetimes.

The influence of mean test fatigue lifetimes on the 95 percent confidence reliability achieved at one lifetime is shown in Figure 11. The figure shows that for a single article fatigue test, a minimum fatigue life of 13.6 lifetimes is required in order to achieve a B-basis reliability. The required mean life for a ten article fatigue test is 8.1 lifetimes.

The B-basis fatigue life to mean life ratio as a function of sample size at $\alpha = 1.25$ (modal value) and 2.17 (mean value) is presented in Figure 12. Figure 12 shows that at the modal value of α (1.25), and a sample size of 20, the B-basis to mean life ratio is 0.136. That is, a minimum life factor of 7.35 is required to obtain a B-basis reliability with 20 tests. For a sample size of one the required factor is 13.6. It should be noted that B-basis life reduction factor is very sensitive to the value of α . For $\alpha = 2.17$ and a sample size of one, the B-basis reduction factor is reduced to 4.2. Figure 13 presents details of the influence of α on fatigue life ratio.

The 95 percent confidence reliability as a function of required fatigue life to mean failure life ratio (X/\bar{x}) is shown in Figure 14 for sample size of 1, 5 and 30. Figure 14 shows that the reliability becomes very low if the required fatigue life is greater than 0.2 of the mean fatigue test life.

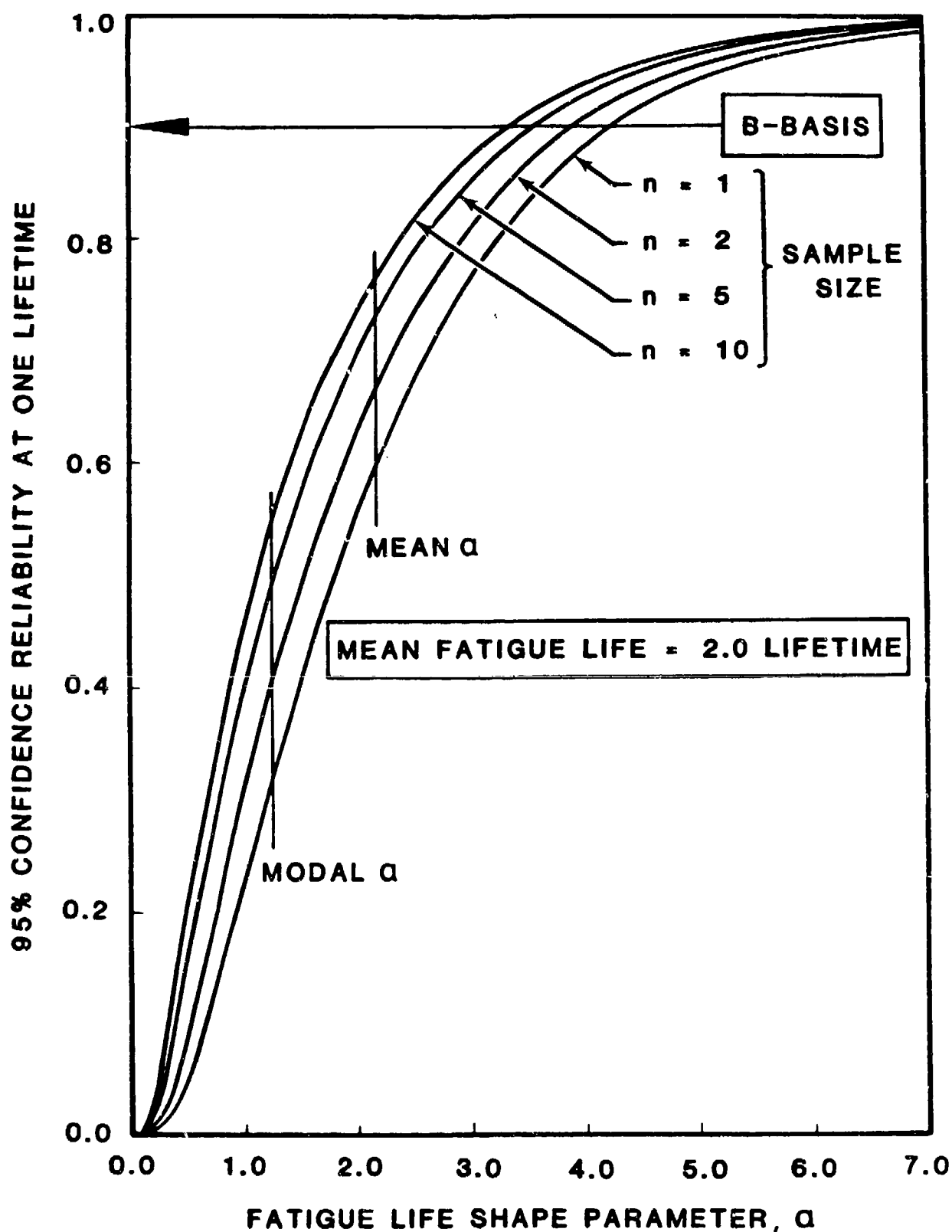

FIGURE 10. INFLUENCE OF FATIGUE LIFE SHAPE PARAMETER ON RELIABILITY DEMONSTRATED BY A TWO-LIFETIME FATIGUE TEST.

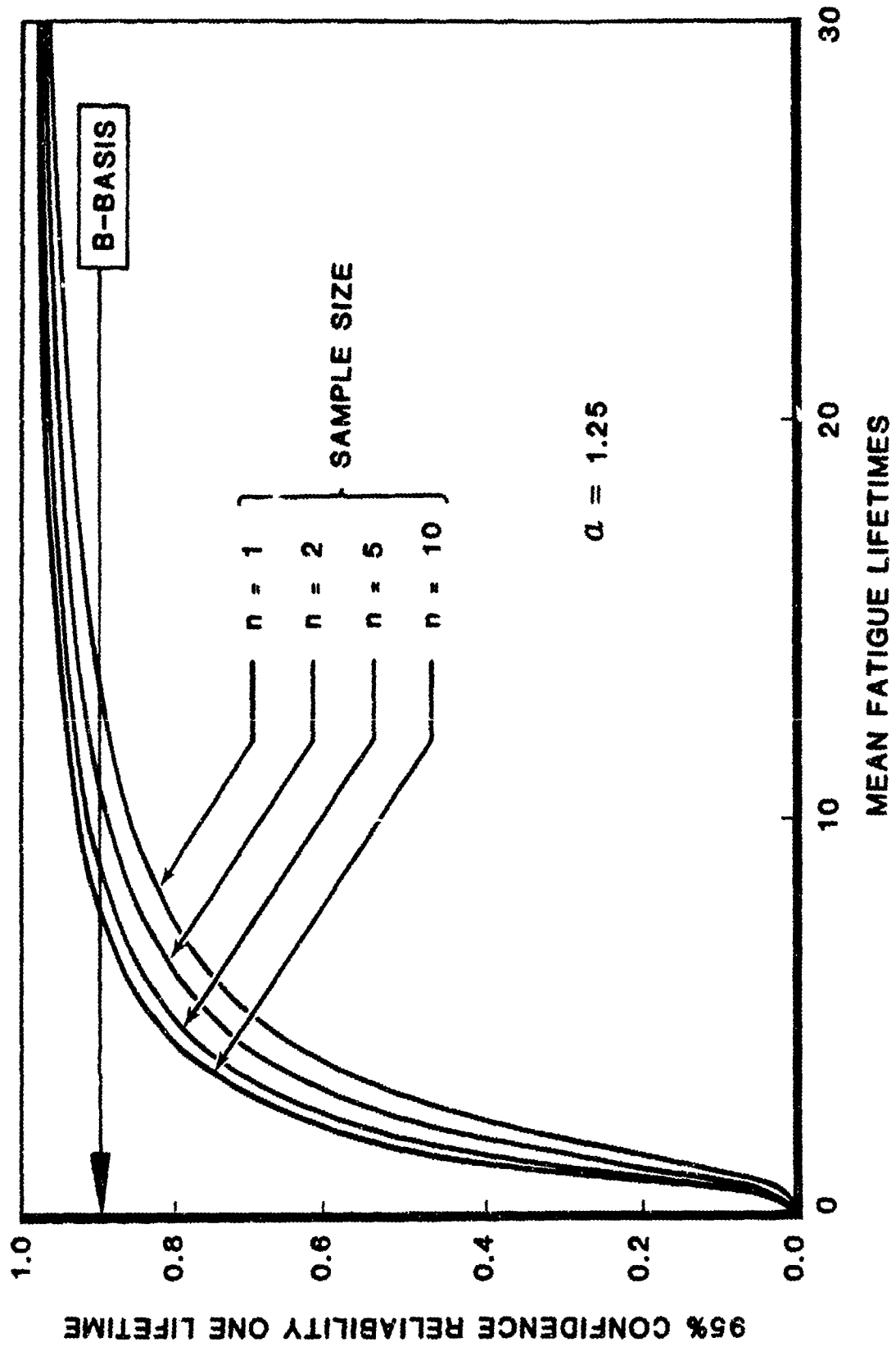

FIGURE 11. INFLUENCE OF MEAN TEST LIFETIME ON THE RELIABILITY ACHIEVED AT ONE LIFETIME.

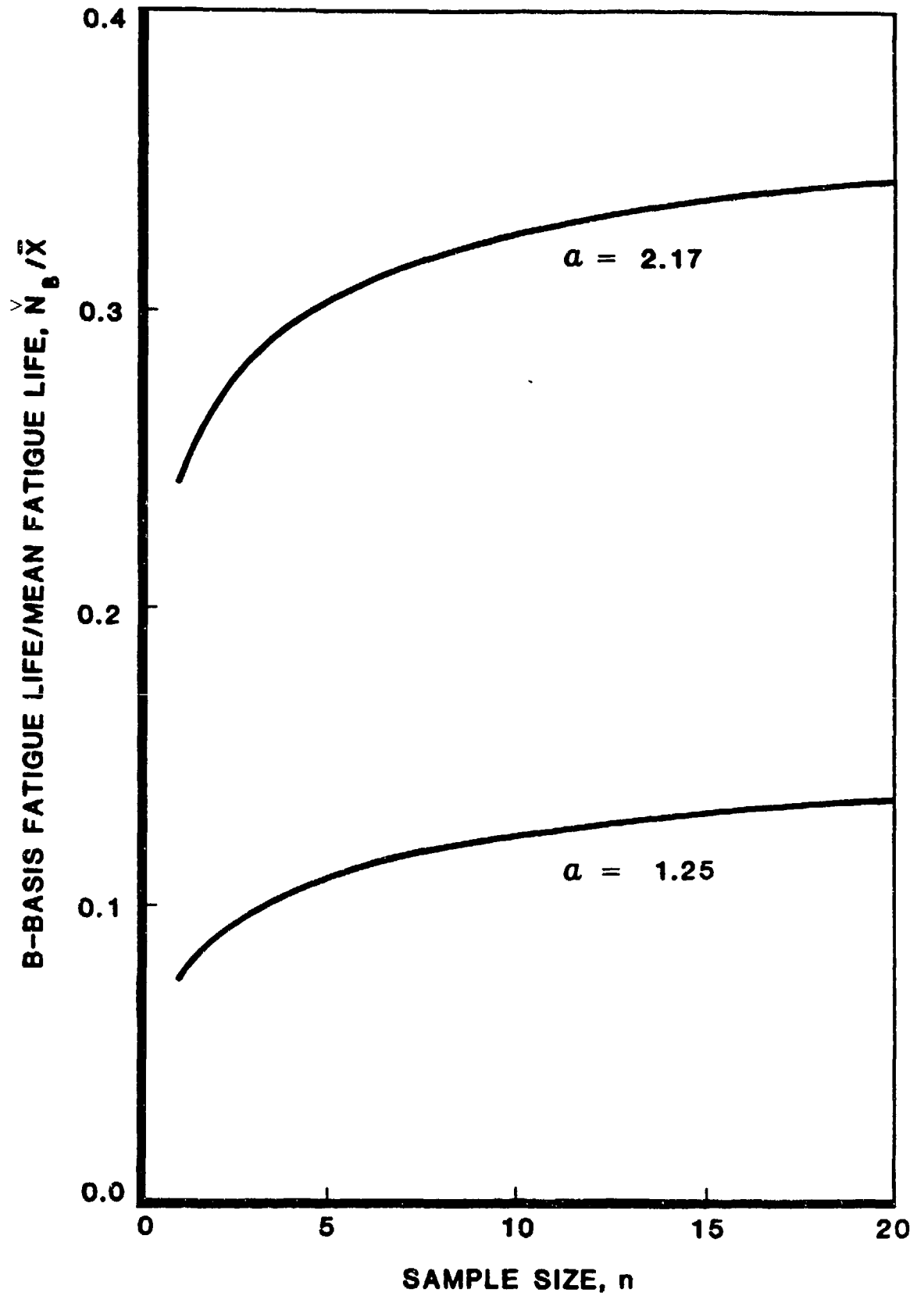

FIGURE 12. INFLUENCE OF SAMPLE SIZE ON B-BASIS FATIGUE LIFE TO MEAN FATIGUE LIFE RATIO.

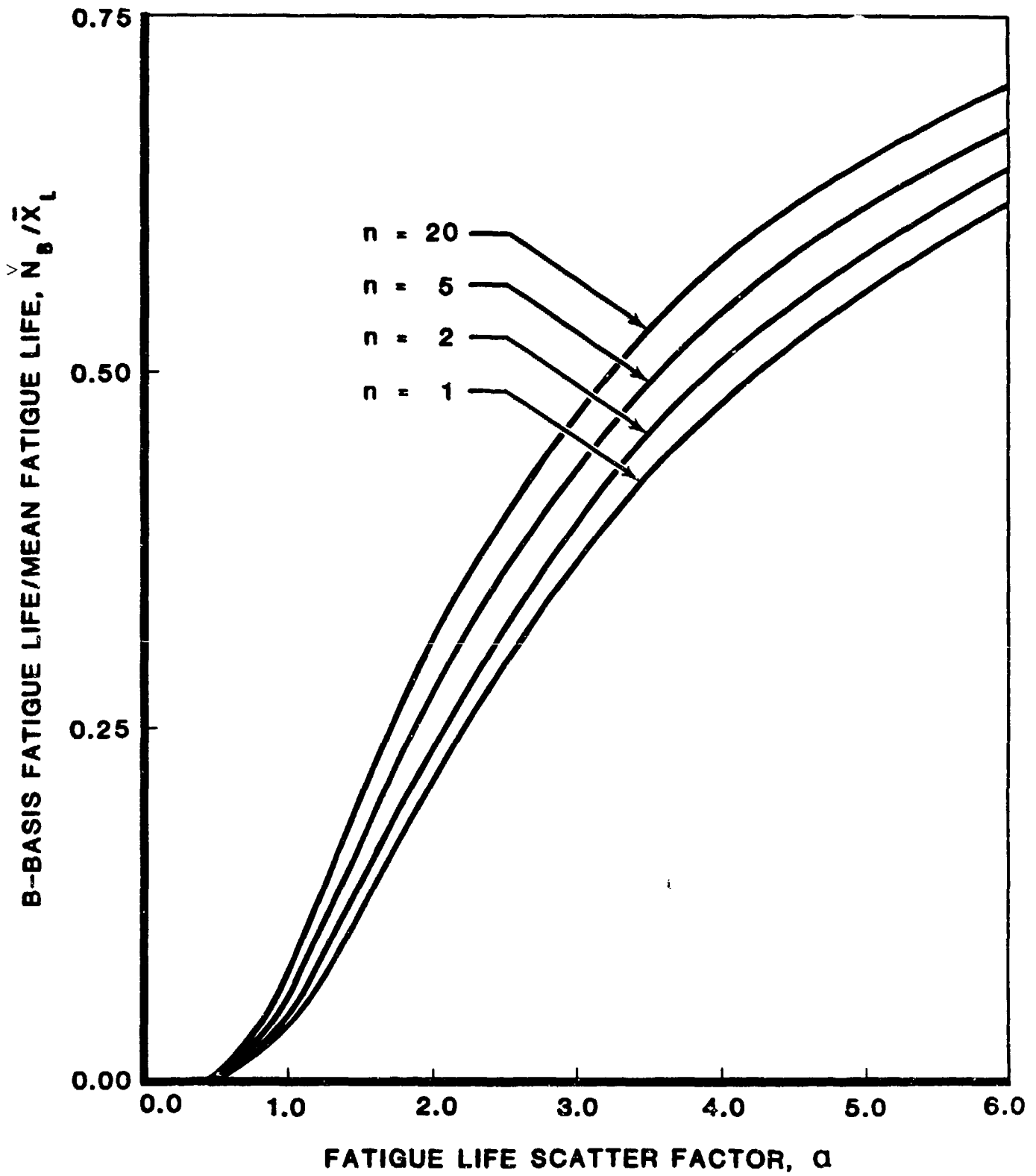

FIGURE 13. INFLUENCE OF FATIGUE LIFE SCATTER ON B-BASIS FATIGUE LIFE TO MEAN FATIGUE LIFE RATIO.

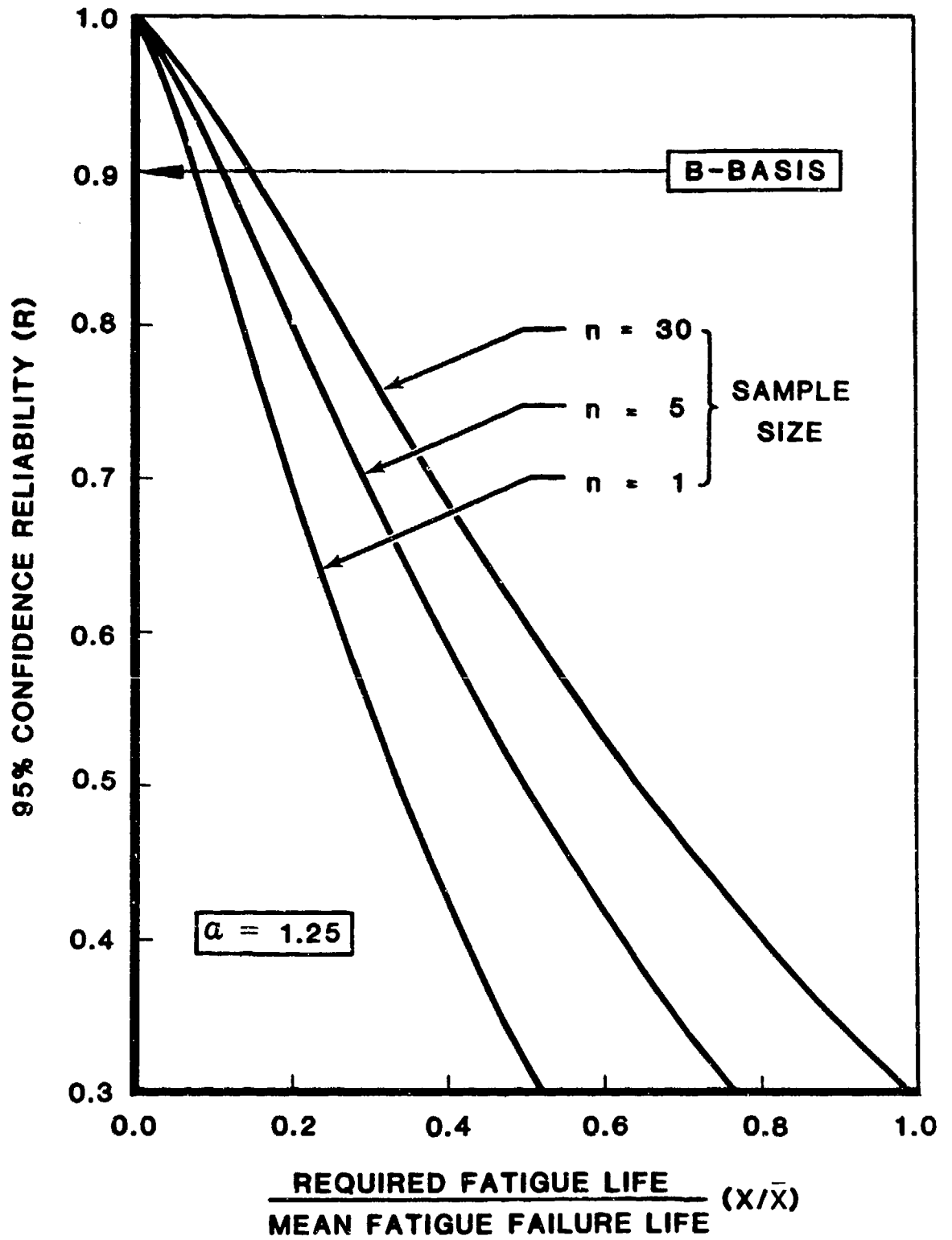

FIGURE 14. INFLUENCE OF REQUIRED FATIGUE LIFE TO MEAN TEST LIFE RATIO ON FATIGUE RELIABILITY.

2.1.3 Assessment of the Navy Certification Approach

The Navy certification approach to primary composite structures was evolved approximately ten years ago. It has been well documented in References 1 through 4. The Navy composite certification approach was evolved from their extensive metallic certification experience. As such, it relies heavily on the scatter factor approach. An assessment of the Navy certification approach to static strength and fatigue life is discussed below.

2.1.3.1 Static Strength

Two requirements are specified for full-scale structural tests:

- (1) The actual room temperature failure load is required to exceed the 150 percent design limit load (DLL) value by a compensation factor dependent on failure location, failure mode, metal or composite structure, environmental test condition and material variability.
- (2) At 150 percent design limit load, all measured and extrapolated strains must not exceed the allowable strain level for the worst environmental condition.

These requirements are shown schematically in Figure 15 for the case of an environmentally sensitive failure in a composite upper skin. From Figure 15 the requirements above are expressed as

$$\epsilon_T^{150\%} \leq \epsilon_D^E$$

$$P_{FP} \geq P_{FR}$$

$$\frac{P_{FR}}{P_{150\%}} \geq \frac{\epsilon_D^{RT}}{\epsilon_D^E}$$

The use of this approach for full-scale static test requirements is based on three key assumptions:

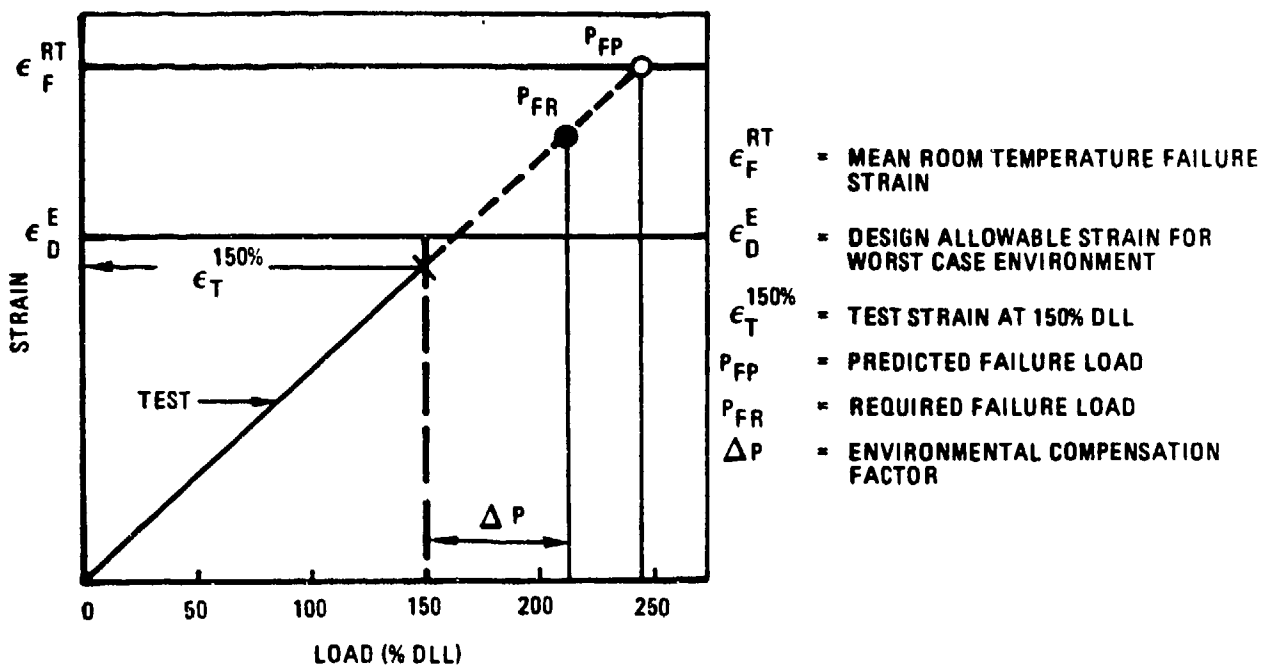

FIGURE 15. F/A-18A AND AV-8B LOAD-STRAIN ASSESSMENT CONCEPT.

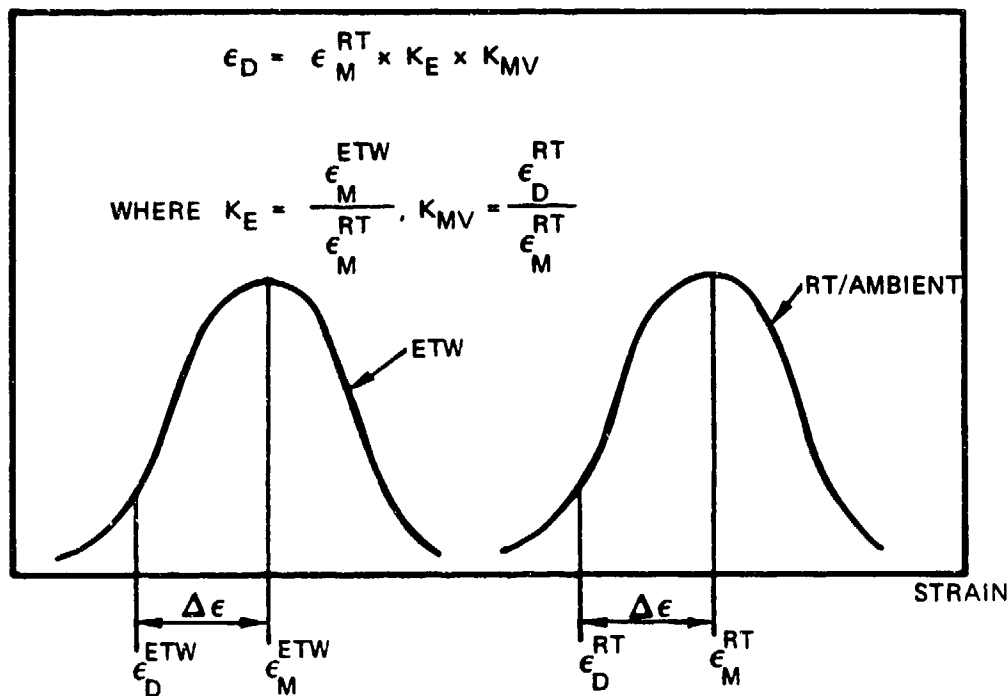

FIGURE 16. SCHEMATIC OF THE CALCULATION OF DESIGN ALLOWABLE STRAIN LEVEL (REFERENCE 1)

- (1) The variability of composite strength data is independent of environment,
- (2) Load-strain response is linear to structural failure, and,
- (3) Failure modes are correctly predicted; i.e., no unexpected hot spot failure occurs.

The validity and implications of these assumptions for structural reliability are discussed below.

Composite Static Strength Variability

Design strain allowables for each failure mode and its critical environment are determined by assuming composite strength variability are independent of environment. Figure 16 shows an example of this procedure for an environmentally sensitive failure mode (Reference 1). Initially RTA tests are carried out to determine mean strength and material variability. This permits determination of a room temperature design allowable strain, ϵ_D^{RT} . Next, sufficient tests are carried out in the hot/wet environment to establish mean failure strain, ϵ_M^{ETW} . Variability in the hot/wet environment is assumed to be the same as in the room temperature ambient environment. The hot/wet design allowable is then obtained as:

$$\epsilon_D^{ETW} = \frac{\epsilon_D^{RT}}{\epsilon_{Mean}^{RT}} \cdot \epsilon_{Mean}^{ETW} \quad (5)$$

This design allowable, ϵ_D^{ETW} , accounts for environmental sensitivity and inherent material variability, but not structural response variability.

The influence of environment on tension and compression static strength scatter was determined in Task I (see Volume I). A large static strength data base was analyzed. It was shown that for tension failures static strength variability was higher

in ETW environments. In contrast, for the hot/wet sensitive compression failures no influence of environment was observed. However, the work in Task I showed that failure mode more significantly influenced static strength scatter. The work in Reference 5 also showed that failure mode exercised the greatest effect on static strength scatter.

The test data analysis in Task I, therefore, suggests that the assumption of environmental independence for static strength scatter may not always be strictly correct. However, the requirement specified in the Navy approach, which mandates the determination of strength variability for each failure mode, is a key requirement because of its dominating influence on static strength variability.

In general, it can be concluded that the Navy approach to static strength variability is soundly based, despite evidence of some influence of environment on strength variability.

The soundness or conservatism of the Navy approach can be improved by specifying conservative strength variability knockdown factors for each failure mode. This would tend to take into account any dependence of variability on environment.

Linear Load-Strain Response

The second assumption in the Navy certification approach is that of linear load-strain response. This was justified because previous testing of composite structures consistently showed linear load-strain response. However, work in Reference 5 has shown that nonlinear load-strain response can occur under severe hot/wet test conditions. An example, from Reference 5, of nonlinear upper skin load-strain response in a box beam under 250°F/1.3% moisture conditions is shown in Figure 60. It is discussed in more detail in Section 3 of this report.

Figure 17 shows the implications of nonlinear ETW load-strain response for the Navy certification approach. The RTA test load-strain response shown fulfills all certification re-

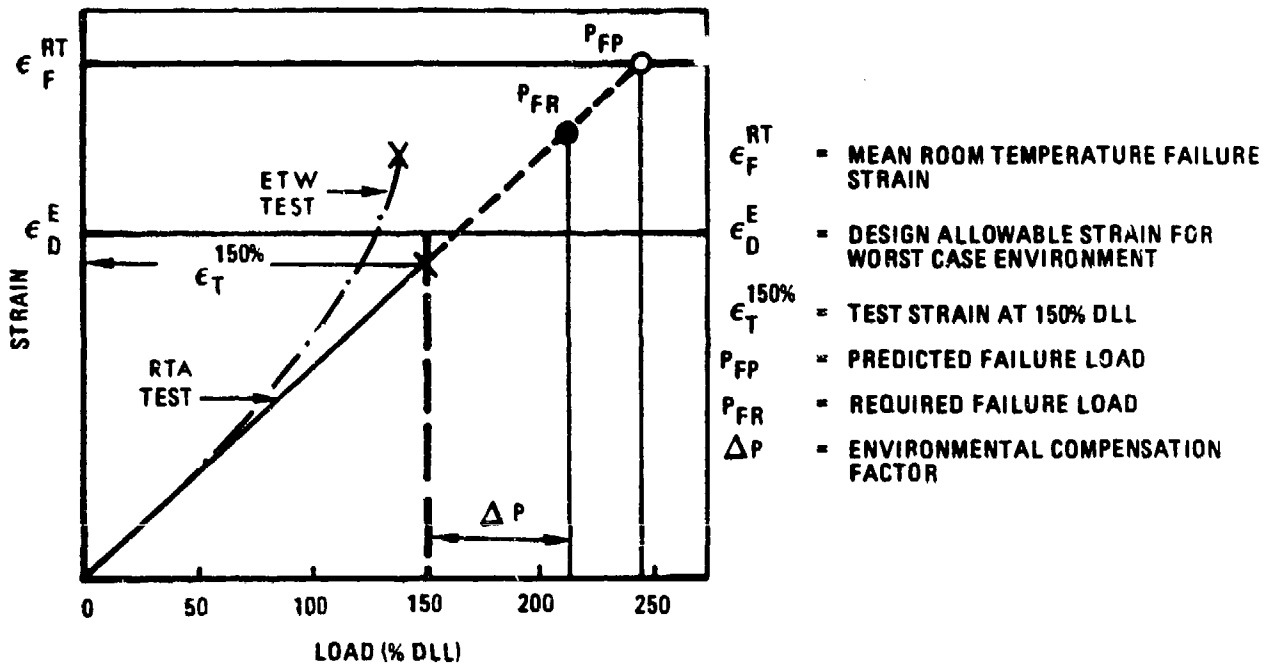

FIGURE 17. INFLUENCE OF NONLINEAR LOAD-STRAIN RESPONSE ON THE F/A-18A AND AV-8B LOAD-STRAIN ASSESSMENT CONCEPT.

quirements and demonstrates adequate margin for the environmental compensation factor. The ETW load-strain response plotted in Figure 17 represents a worst case scenario. The nonlinear ETW response causes the ETW strain allowable ϵ_D^E to be exceeded before design ultimate load, which leads to failure at less than design ultimate load. This example shows the potential danger in using RTA tests with environmental compensation factors to demonstrate certification compliance. It is important, therefore, in composite structures to conduct environmental tests on realistic subcomponents in order to avoid the scenario described above. The amount and complexity of the environmental testing will be a function of the aircraft service environment. Alternatively, use of composite materials in their nonlinear load-strain response region should be avoided.

Nonlinear load-strain response in composites is induced in ETW environments by loss of resin mechanical properties. Resin-controlled properties, such as compression strength, are the most sensitive to ETW environments. Strength loss and nonlinear load-strain response occur as the glass transition temperature of the material is approached. Good design practice dictates that composites should not be used in this regime. These problems can, therefore, be avoided by setting the Material Operating Limit (MOL) at a safe margin below the glass transition temperature.

The concept of a Material Operating Limit is discussed in detail in Reference 5 and is shown schematically in Figure 18 for an environmentally sensitive property. The decrease in design allowable strain as temperature increases is shown for a constant moisture level. The glass transition temperature (T_g) of the material coincides with a catastrophic rate of strength loss. In order to operate in a safe regime, the MOL should be reduced below the T_g by a safety factor K . This produces the shaded service operational envelope for the material shown in Figure 18. Figure 19 shows how the MOL varies with moisture level, such that a series of MOL's are produced for various

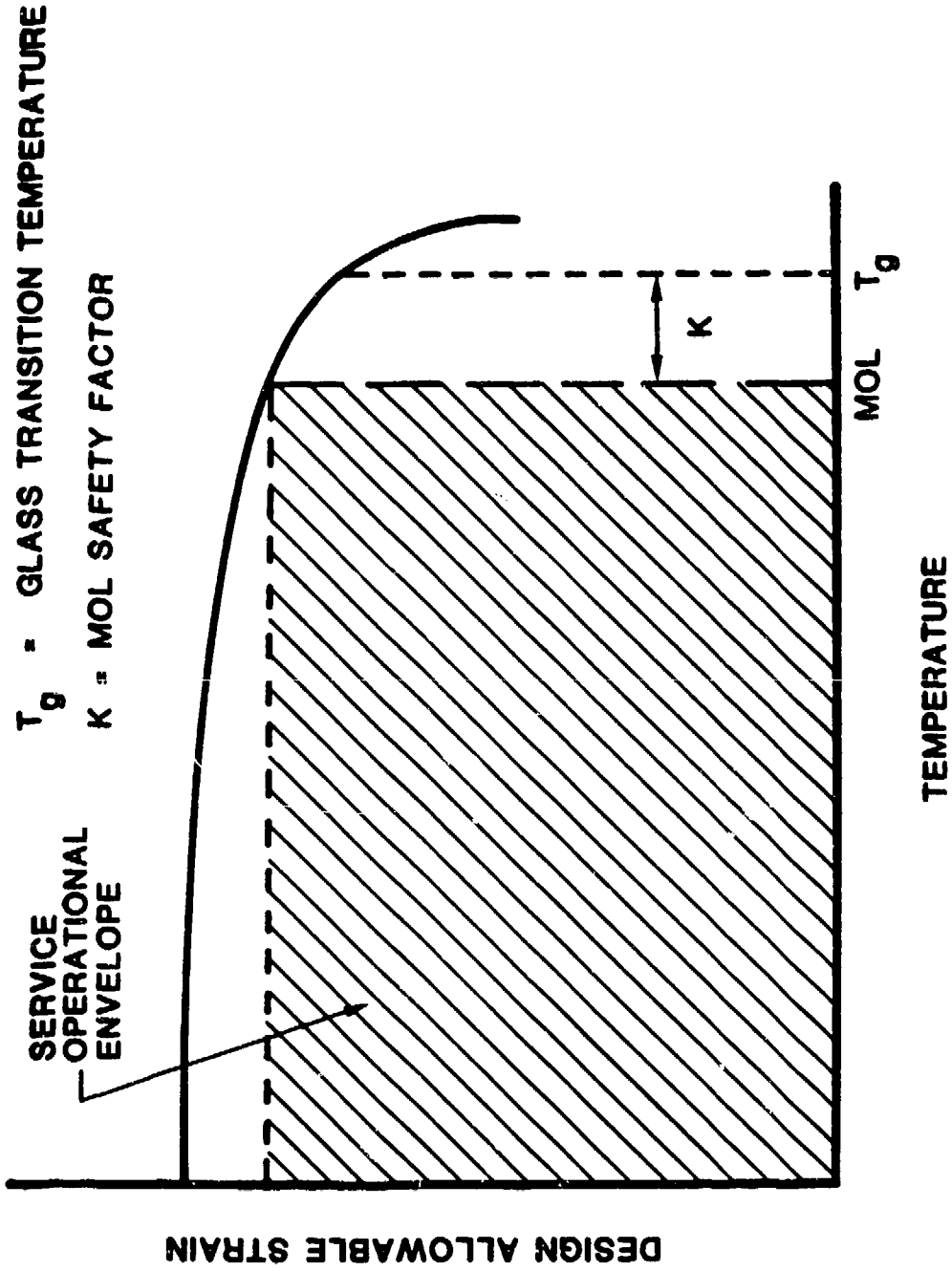
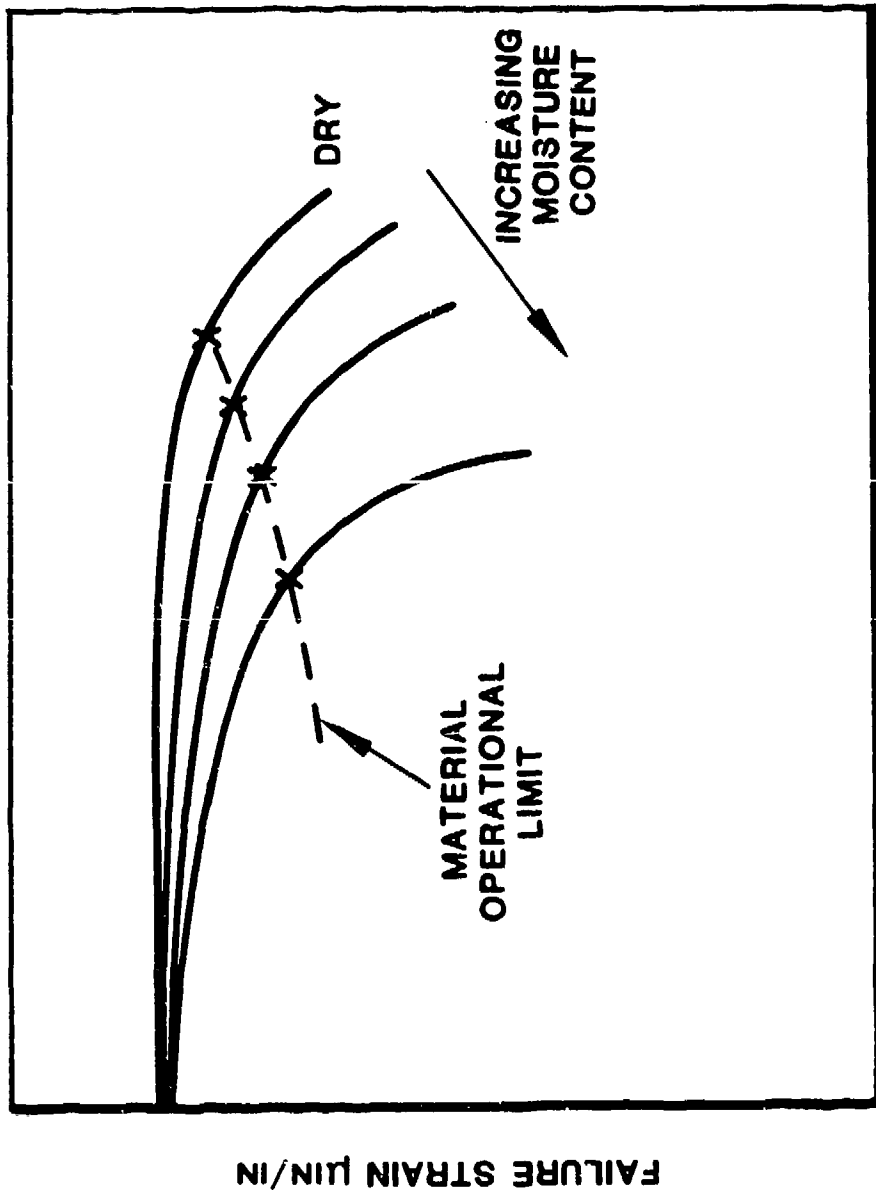

FIGURE 18. MATERIAL SELECTION CRITERION.



TEMPERATURE °F

FIGURE 19. INFLUENCE OF TEMPERATURE AND MOISTURE ON MATERIAL OPERATIONAL LIMITS.

moisture levels. If the service environment (temperature/moisture) of the aircraft falls within the MOL, excessive environmental effects can be avoided. If this procedure is adopted, the assumption of linear load-strain response is soundly based.

Correct Failure Mode Prediction

Use of an environmental compensation factor in an RT/ambient static test, requires the correct prediction of both RTA and ETW failure modes.

A typical application of this approach, would be a RTA test of a wing structure whose critical failure mode is upper skin failure under ETW conditions. In this application, the load-strain response shown in Figure 15 would represent the RTA upper skin load-strain response. The environmental compensation factor Δp (P_{DUL} to P_{FR}) represents the strength loss at ETW conditions. Extrapolation of the strain data to P_{FP} assumes the correctly predicted upper skin failure mode occurs. If an unanticipated ETW failure mode occurs, it is possible that failure could occur at less than DUL.

This is an important observation because prediction of previous composite full-scale static test failure modes has been inadequate. Examples are given in References 5 through 7. In Reference 5, the predicted RTA failure mode was lower skin failure; however, the observed failure mode was failure of the intermediate spar/lower skin cocured joints. Despite this, the wing box sustained 122 percent of DUL at failure.

Reference 6 reported that the failure mode of a Jaguar aircraft composite wing box was different from that predicted with lower complexity level specimen tests. In Reference 7, the failure modes of the three full-scale structural tests from the ACEE program were reviewed. In all three tests, static failure were induced by unanticipated failure modes. The majority of unexpected failure modes discussed in References 5 through 7 can be attributed to the sensitivity of composites to out-of-plane

loading. This is caused by their relatively low interlaminar tension and shear strength. The major sources of secondary loads are those induced directly such as fuel pressure loading and those induced indirectly by eccentricities, irregular shapes, stiffness changes, discontinuities and loading in the postbuckling regime. The lesson learned from these experiences is that composite structures are much more sensitive to secondary load induced hot spots than metals. Therefore, great care should be exercised in understanding and accounting for these loads in the design process.

The conclusion from the above discussion on the Navy assumption of predicted failure mode is as follows. The failure modes of full-scale composite structures cannot currently be predicted with great confidence. Therefore, a certification process which assumes correct prediction of a full-scale structural failure mode must carry some degree of risk.

2.1.3.2 Fatigue Strength

The Navy approach to fatigue certification of composite structures is similar to that adopted for metals: that is, a two-lifetime RTA fatigue test with a severe design spectrum. This approach has proved successful for identifying fatigue hot spots in metallic structures.

The major problem in certifying composite structures is related to their excellent fatigue resistance. This causes their S-N curves to be relatively flat with significantly higher data scatter. Thus, a two-lifetime test on a composite structure demonstrates a lower reliability than for metal structures.

2.1.4 Example Reliability Calculations

In this subsection, a static strength and a fatigue life problem are selected to demonstrate the reliability calculation procedure using the scatter factor approach. Composite structure as well as metal structure are used in both examples.

2.1.4.1 Static Strength Reliability

Determine the requirements necessary to demonstrate B-basis static strength reliability for an (a) all composite, (b) all metal wing structure of a supersonic fighter aircraft. Assume the following:

- (1) A maximum service temperature of 220°F
- (2) Environmental (ETW) knockdown factor $k^C = 1.2$,
 $k^m = 1.0$
- (3) Static strength variability $\alpha_S^C = 20$, $\alpha_S^m = 25$
- (4) Maximum operating load, $X = 1.25 \times \text{DLL} =$
 $0.833 \times \text{DUL}$
- (5) One full-scale test article, $n = 1$
- (6) Ignore structural response variability, $\text{SRV} = 0$

Composite Wing

From Figure 9, for $k^C = 1.2$ and B-basis reliability (95 percent confidence, 90 percent reliability), the maximum operating load (X) to static failure load (\bar{x}) ratio is

$$\frac{X}{\bar{x}} = 0.725$$

Required failure load $\bar{x} = x/0.725$

For $X = 0.833 \times \text{DUL}$:

$$\bar{x} = \frac{0.833}{0.725} \text{ DUL} = 1.15 \times \text{DUL}$$

Therefore, the static test article must exceed 115 percent DUL to demonstrate B-basis reliability at the maximum operating load of 125 percent DLL.

Metal Wing

For B-basis reliability, the maximum operating load to static failure load ratio for $\alpha_S^m = 25$ and $k^m = 1.0$ is calculated to be

$$\frac{X}{\bar{x}} = 0.894$$

or the required failure load

$$x = \frac{X}{0.894}$$

For $X = 0.833 \times \text{DUL}$

$$\bar{x} = \frac{0.833}{0.894} \times \text{DUL} = 0.932 \times \text{DUL}$$

Therefore, the static strength of the test article must exceed 93 percent of DUL to accommodate B-basis reliability at the maximum operating load of 125 percent DLL.

The calculations above show that, for the example cited, the composite wing would have to achieve a 24 percent higher failure load in order to demonstrate the same structural reliability.

Mixed composite/metal structures pose special certification problems. These have been discussed in detail in Reference 8. In this reference, it was shown that because of their lower variability in mechanical properties and lower environmental sensitivity, the metal portion of a mixed structure would fail first in a RTA test. Historically, metal structures have exhibited full-scale test failure loads of approximately 105 percent DUL. Thus, for a mixed structure where a metal failure occurs at 105 percent DUL, the reliability of the composite structure will be unknown. The proven reliability of the composite structure (based on a minimum strength of 105 percent DUL) will be only 0.54. Thus, certification of both parts of a mixed structure to the same reliability may be difficult to achieve.

2.1.4.2 Fatigue Life Reliability

Determine the requirements necessary to demonstrate B-basis fatigue life reliability for an (a) all composite, (b) all metallic wing structure of a supersonic fighter aircraft. Assume the following:

- (1) Fatigue life variability $\alpha_L^C = 1.25$, $\alpha_S^m = 7.5$
- (2) One full-scale test article, $n = 1$
- (3) Ignore structural response variability, $SRV = 0$.

Composite Wing

The life factor requirement for B-basis reliability for $\alpha_L^C = 1.25$ and $n = 1$ can be obtained from Figure 11, it is 13.6. Thus, in order to demonstrate B-basis reliability at one lifetime, a successful test to 14 lifetimes must be achieved.

Metal Wing

The life factor for $\alpha_L^m = 7.5$ and $n = 1$ is calculated to be 1.5. Thus, a two-lifetime fatigue test is more than adequate to demonstrate B-basis reliability at one lifetime. Actual reliability for a two-lifetime test is 0.99.

The Navy two-lifetime certification test philosophy for composites demonstrates only 0.32 reliability at one lifetime. However, if actual service usage is less severe than the conservative design spectrum, this reliability will be improved. For example, if the actual service loads are 1.13 times lower than the design spectrum a B-basis reliability at one lifetime will be achieved. Thus, the reliability of Navy aircraft will vary and will depend on the conservatism of the severe design spectrum.

The RTA full-scale fatigue test does not account for any environmental fatigue effects. The influence of environment on composite fatigue life has been comprehensively investigated in Reference 5. The issue of environmental test simulation for a composite certification program was addressed. It was shown that the requirements for environmental simulation were closely related to the aircraft temperature spectrum and the relationship between load factor and temperature.

Typical examples, from Reference 5, of these relationships for a fighter aircraft are shown in Figures 20 and 21, respectively. The Mach 2 class aircraft utilized in Reference 5 had a maximum service temperature of 242°F. This design tempera-

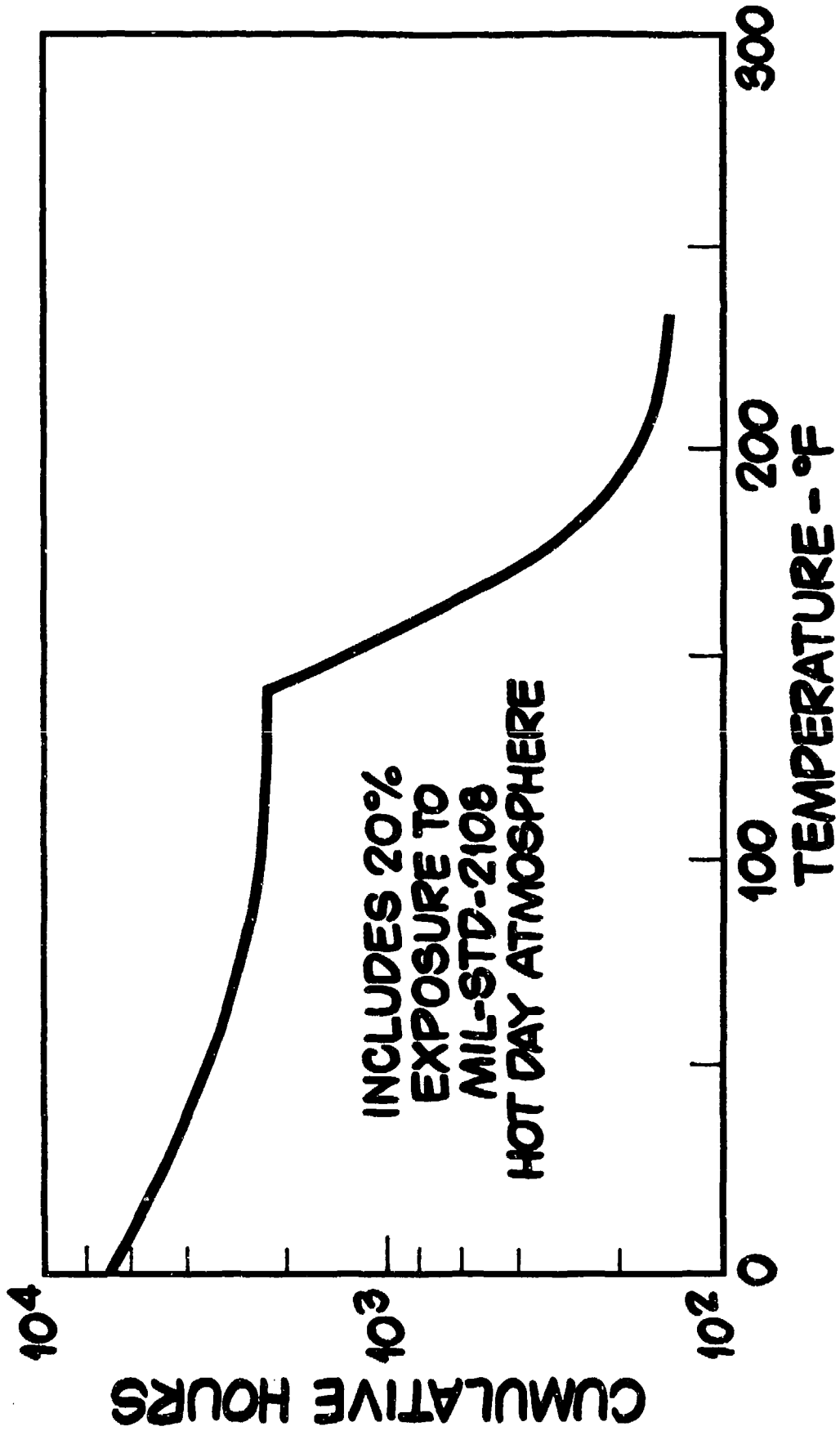

FIGURE 20. TEMPERATURE SPECTRUM FOR MACH 2 FIGHTER AIRCRAFT IN REFERENCE 5.

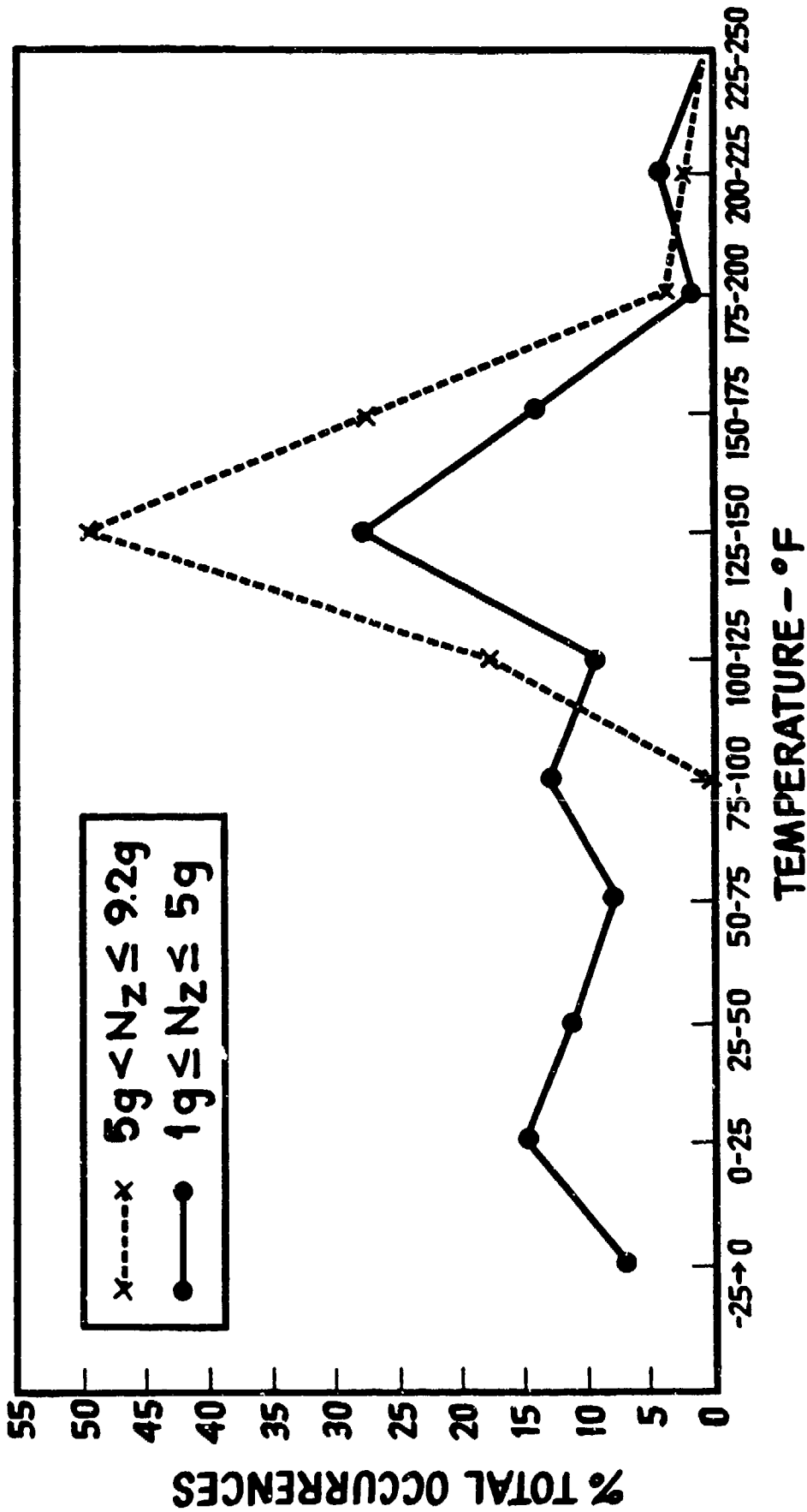

FIGURE 21. LOAD-FACTOR TEMPERATURE RELATIONSHIP FOR MACH 2 FIGHTER AIRCRAFT IN REFERENCE 5.

ture was associated with the most critical static design case. However, the fatigue temperature spectrum shown in Figure 20 shows two interesting features. First, the maximum temperature in the fatigue spectrum is 220°F and, second, the aircraft spends less than 200 hours/lifetime at temperatures above 200°F. This represents approximately only 2.5 percent of the total life. The vast majority of the aircraft life is spent at semi-ambient temperatures.

Figure 21 shows the load factor-temperature relationship of the Reference 5 aircraft. Noticeable features of the relationship are (1) the low number of load factor occurrences above 200°F, less than 5 percent of the total, (2) the vast majority of 5g to 9g loads (the most fatigue damaging) occur at semi-ambient temperature, 100°F to 175°F.

Because of the low cumulative time at high temperatures and the semi-ambient temperatures associated with high load factors, it can be concluded that full-scale RTA testing is satisfactory for fatigue certification of this type of fighter aircraft.

The implications of the load-temperature relationships and the test data generated in Reference 5 for environmental test complexity have been discussed in more comprehensive detail in References 9 through 13.

Since the relationship shown in Figures 20 and 21 are considered to be typical for current fighter aircraft, it can be concluded that the Navy philosophy is a reasonable approach for fighter aircraft. It should be noted, however, that, for aircraft which have significant periods of cumulative time at high temperatures and/or combinations of high load factors and high temperature, RTA tests may not be adequate. ETW subcomponent tests may be required under these circumstances.

2.2 Load Enhancement Factor Approach

The objective of this approach is to increase the applied loads in the fatigue certification tests so that the same

level of reliability can be achieved with a shorter test duration. A schematic showing this approach is shown in Figure 22 where the fatigue life scatter represented is typical of that observed in composites. At one fatigue lifetime a typical residual strength distribution is shown. If the maximum applied load in the fatigue test (P_F) is increased to the mean residual strength at one lifetime (P_T), then the B-basis residual strength of the structure would be equivalent to the design maximum fatigue stress.

Thus, a successful fatigue test to one lifetime at applied stress P_T or a fatigue test to N_F lifetimes at applied stress P_F would both demonstrate B-basis reliability. In addition, combinations of the load enhancement and fatigue life factors could also be used to demonstrate B-basis life. In order to use this approach with confidence in a certification methodology, a formal relationship between the load enhancement factor (LEF) and the life factor is required.

The fatigue life factor for a B-Basis reliability at one fatigue lifetime can be derived from the basic Weibull distribution, and is given by

$$N_F = \frac{\Gamma\left(\frac{\alpha_L + 1}{\alpha_L}\right)}{\left[\frac{-\ln(0.9)}{\chi^2_{\gamma}(2n)/2n}\right]^{1/\alpha_L}} \quad (6)$$

where N_F is the life factor for B-basis reliability at one lifetime.

The residual strength distribution at a certain fatigue lifetime can be described as a two-parameter Weibull distribution, as in the static strength distribution. Let α_R and β_R be the shape and scale parameters of the residual strength distribution and P_T be the mean residual strength. then P_T can be written as

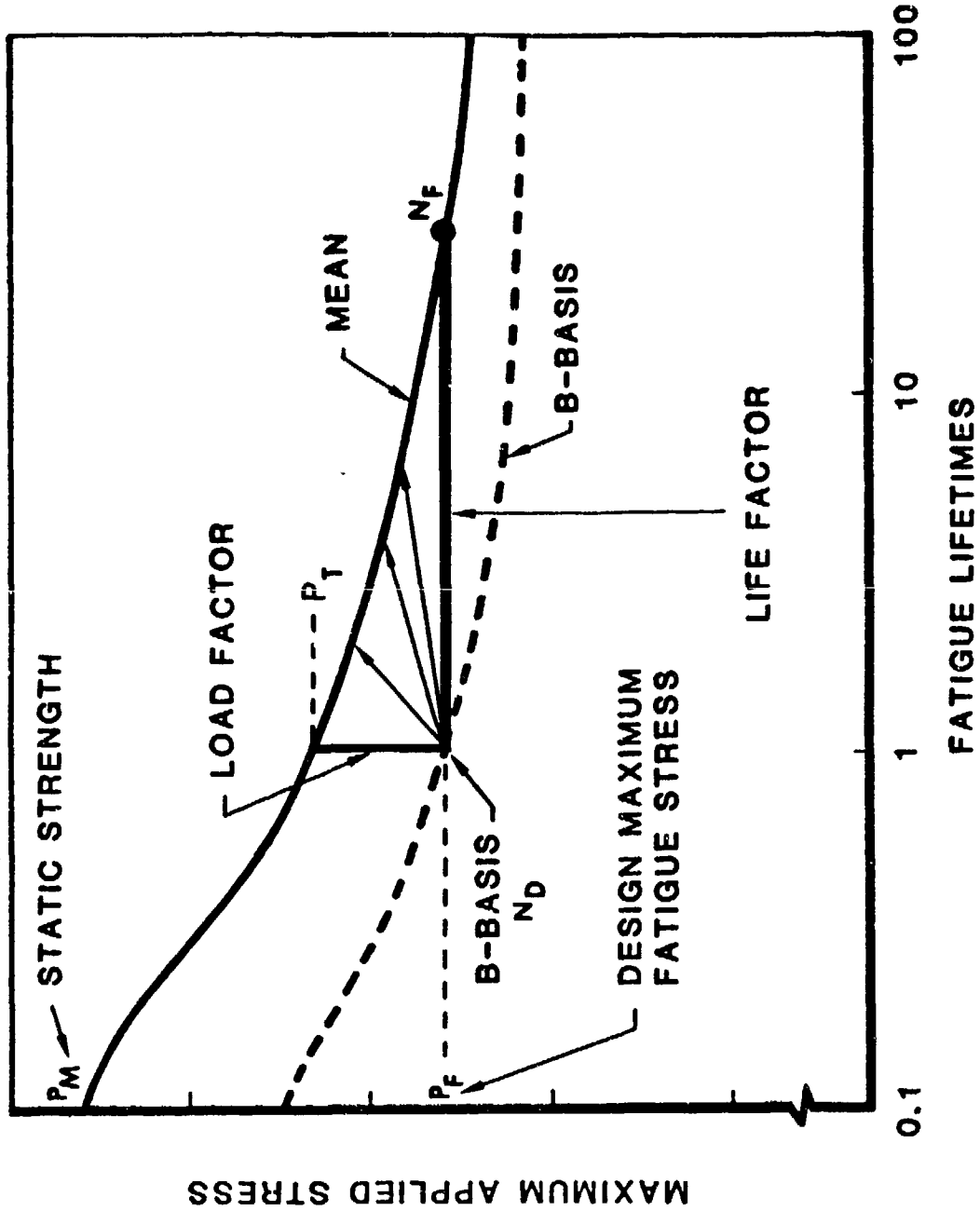

FIGURE 22. SCHEMATIC OF LOAD ENHANCEMENT FACTOR APPROACH FOR COMPOSITES.

$$P_T = \beta_R \Gamma\left(\frac{\alpha_R + 1}{\alpha_R}\right) \quad (7)$$

and the B-basis residual strength is

$$\sqrt[N]{N_R} = \beta_R \left[\frac{-\ln(0.9)}{\chi_\gamma^2(2n)/2n} \right]^{1/\alpha_R} \quad (8)$$

From Figure 22, the load enhancement factor F is defined as

$$F = \frac{P_T}{P_F} \quad (9)$$

where P_T is the maximum fatigue test load

P_F is the maximum design fatigue load.

Since the load enhancement factor approach provides the same reliability as the life factor approach, the factor F can be written as

$$F = \frac{\mu P_T}{\sqrt[N]{N_R}} = \frac{\mu \Gamma\left(\frac{\alpha_R + 1}{\alpha_R}\right)}{\left[\frac{-\ln(0.9)}{\chi_\gamma^2(2n)/2n} \right]^{1/\alpha_R}} \quad (10)$$

where μ is a coefficient which requires that the load enhancement factor $F = 1.0$ when the test duration is N_F .

The probability of survival, at 95 percent confidence level, for a test duration N is given by

$$p = \exp \left[- \left(\frac{N}{\check{\beta}_L} \right)^{\alpha_L} \right] \quad (11)$$

where $\check{\beta}_L$ is the 95 percent confidence scale parameter.

For the requirement that one lifetime is the B-basis life, then the 95 percent confidence β is given by

$$\check{\beta}_L = \frac{1}{[-\ln(0.9)]^{1/\alpha_L}} \quad (12)$$

and equation (11) becomes

$$p = \exp \left[\ln(0.9) N^{\alpha_L} \right] \quad (13)$$

The conditions $N = N_F$, $F = 1.0$ are used to determine the coefficient μ .

$$\mu = \frac{\left[\frac{-\ln(0.9) N_F^{\alpha_L}}{\chi^2_{\gamma}(2n)/2n} \right]^{1/\alpha_R}}{\Gamma \left(\frac{\alpha_R + 1}{\alpha_R} \right)} \quad (14)$$

or in a more general form

$$\mu = \frac{\left[\frac{-\ln(p) N_F^{\alpha_L + 1}}{\chi^2_{\gamma}(2n)/2n} \right]^{1/\alpha_R}}{\Gamma \left(\frac{\alpha_R + 1}{\alpha_R} \right)} \quad (15)$$

In equation (15), N_F is the life factor with p level of reliability at γ level of confidence at one-lifetime. By substituting equation (7) into equation (15), it can be shown that

$$\mu = \frac{\left[\Gamma\left(\frac{\alpha_L + 1}{\alpha_L}\right) \right]^{\alpha_L / \alpha_R}}{\Gamma\left(\frac{\alpha_R + 1}{\alpha_R}\right)} \quad (16)$$

Therefore, the coefficient μ is a function of α_L and α_R and is independent of the life factor or the sample size.

Finally, the general form of the load enhancement factor is obtained from equation (10) and is written as

$$F = \frac{\mu \Gamma\left(\frac{\alpha_R + 1}{\alpha_R}\right)}{\left[\frac{-\ln(p)}{\chi_\gamma^2(2n)/2n} \right]^{1/\alpha_R}} \quad (17)$$

with

$$p = \exp \left[\ln(l) N^{\alpha_L} \right] \quad (18)$$

where l is the required reliability at γ level of confidence ($\gamma = 0.9$ for B-basis and $\gamma = 0.99$ for A-basis).

Equation (17) together with equation (16), can be used to determine the load enhancement factor. The factor F is computed for different values of α_R , with a fixed α_L , and different values of test duration N .

Figure 23 shows the influence of residual strength scatter, α_R , on the load enhancement factor (LEF) required to demonstrate B-basis and A-basis reliability for a one lifetime test. The relationship is shown for various test replications,

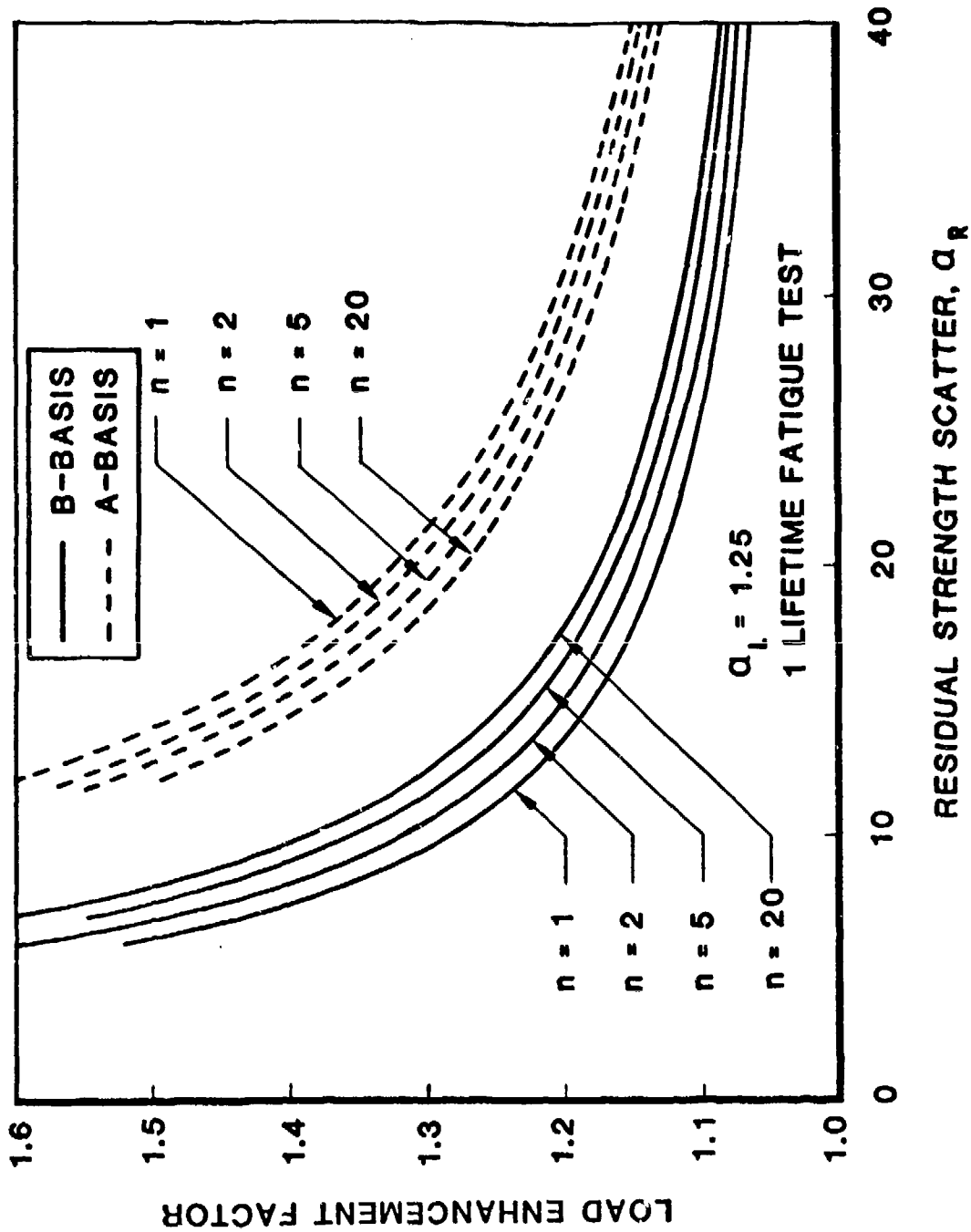

FIGURE 23. INFLUENCE OF RESIDUAL STRENGTH SCATTER α_R ON LOAD ENHANCEMENT FACTOR (ONE LIFETIME FATIGUE TEST)

n. For typical residual static strength scatter ($\alpha_R = 20$), the A-basis and B-basis LEF's are 1.33 and 1.18, respectively, for a one replicate test ($n = 1$). Figure 24 shows the same relationship as Figure 23 for a two lifetime test. The extra lifetime of fatigue testing reduces the LEF's for A-basis and B-basis reliability to 1.27 and 1.13, respectively.

It can be seen from Figure 22 that there are three ways to demonstrate B-Basis reliability:

- (a) Load enhancement factor
- (b) Life factor
- (c) Combined load enhancement and life factors

Equations (16) through (18) have been used to develop relationships between load enhancement factor and life factor (test duration). The relationships have been determined for various combinations of α_L , α_R and n , are shown in Figures 25 and 26. These plots can be used to specify test or design life requirements for composite structures.

The Sendeckyj fatigue data analysis method can also be used to calculate load enhancement factors from experimental fatigue data. The Sendeckyj analysis is described in Reference 14 and summarized in Volume I. This method of analysis was used in Reference 15 to obtain load enhancement factors from experimental data.

The mathematical relationship for LEF's developed in this subsection is also used to check the accuracy of LEF's calculated by the Sendeckyj analysis. This is presented in Figure 27, which shows excellent agreement between the two methods. It can, therefore, be concluded that the Sendeckyj analysis provides good estimates of LEF's from experimental data. This indicates that the assumptions made in the Sendeckyj fatigue analysis method are valid.

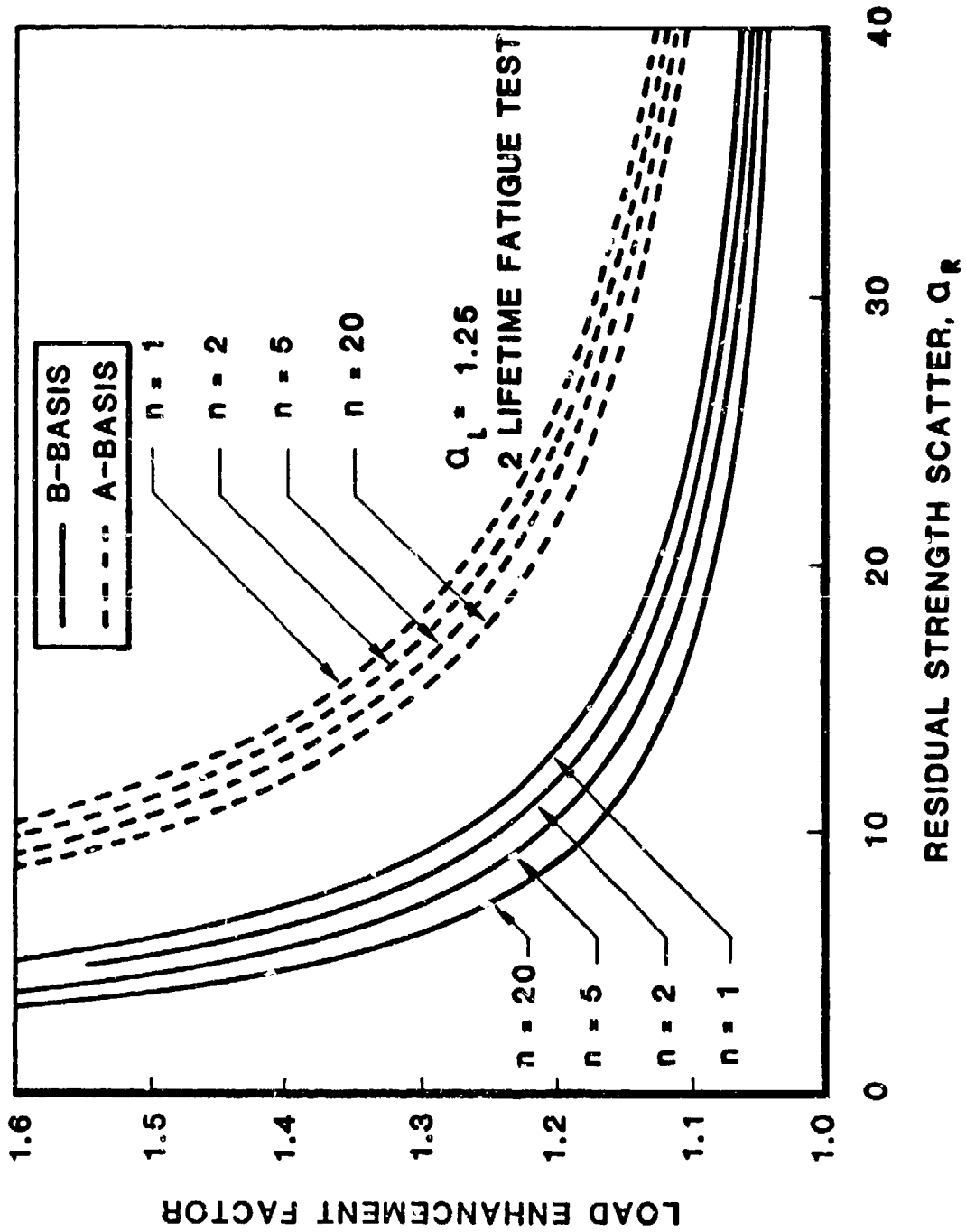

FIGURE 24. INFLUENCE OF RESIDUAL STRENGTH SCATTER, Q_R , ON LOAD ENHANCEMENT FACTOR (TWO LIFETIME FATIGUE TEST)

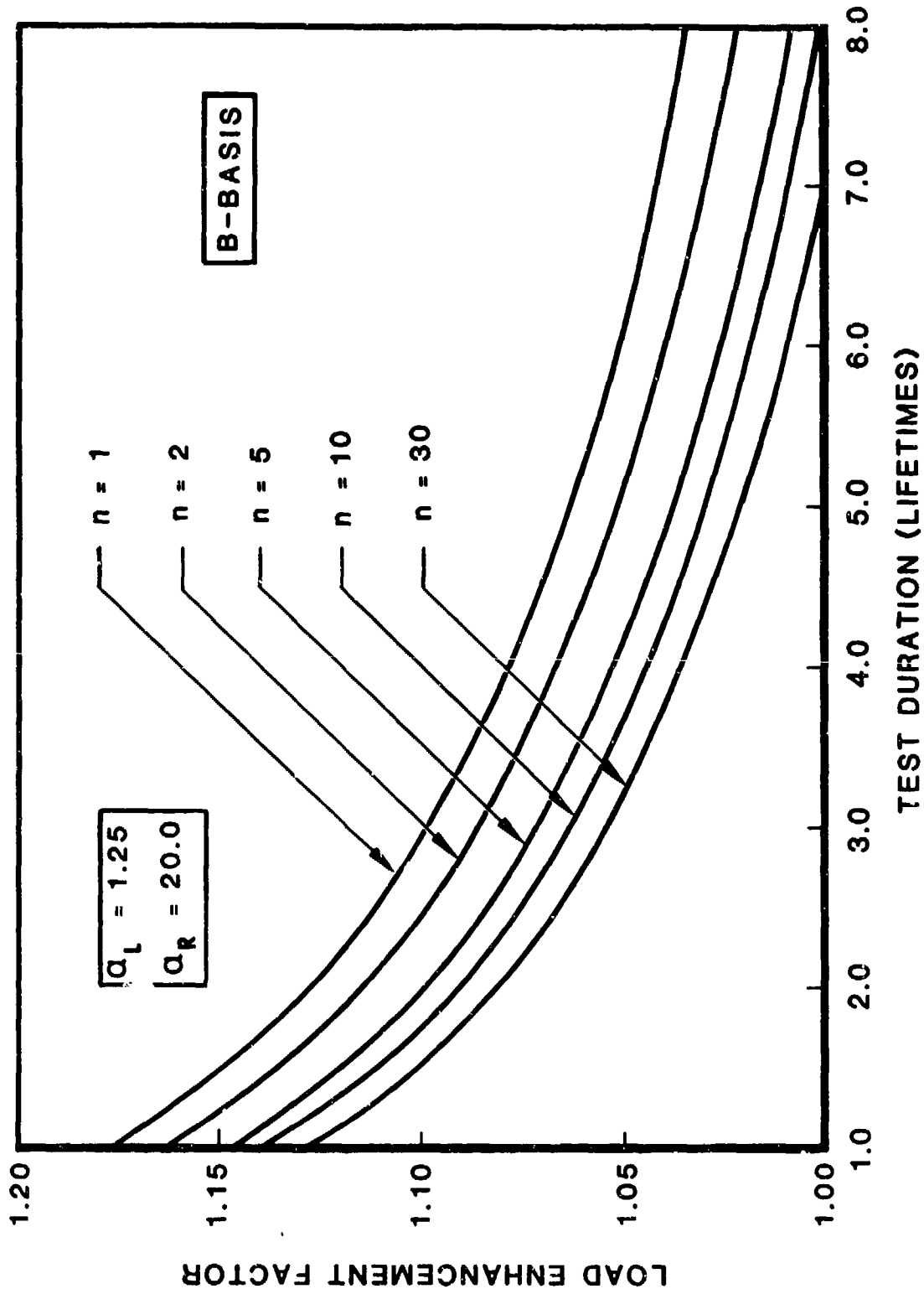

FIGURE 25. INFLUENCE OF TEST DURATION ON B-BASIS LOAD ENHANCEMENT FACTORS.

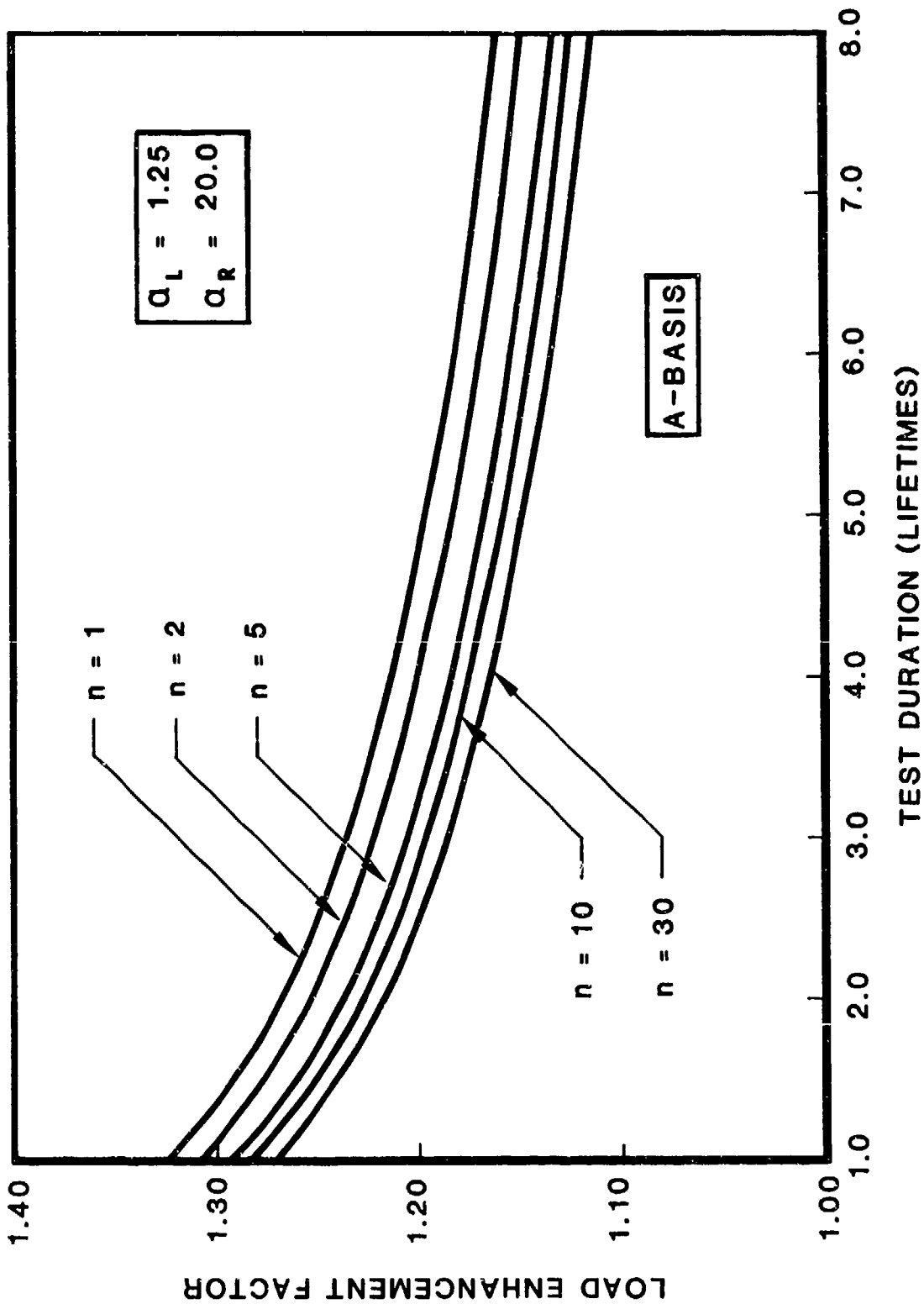

FIGURE 26. INFLUENCE OF TEST DURATION ON A-BASIS LOAD ENHANCEMENT FACTORS.

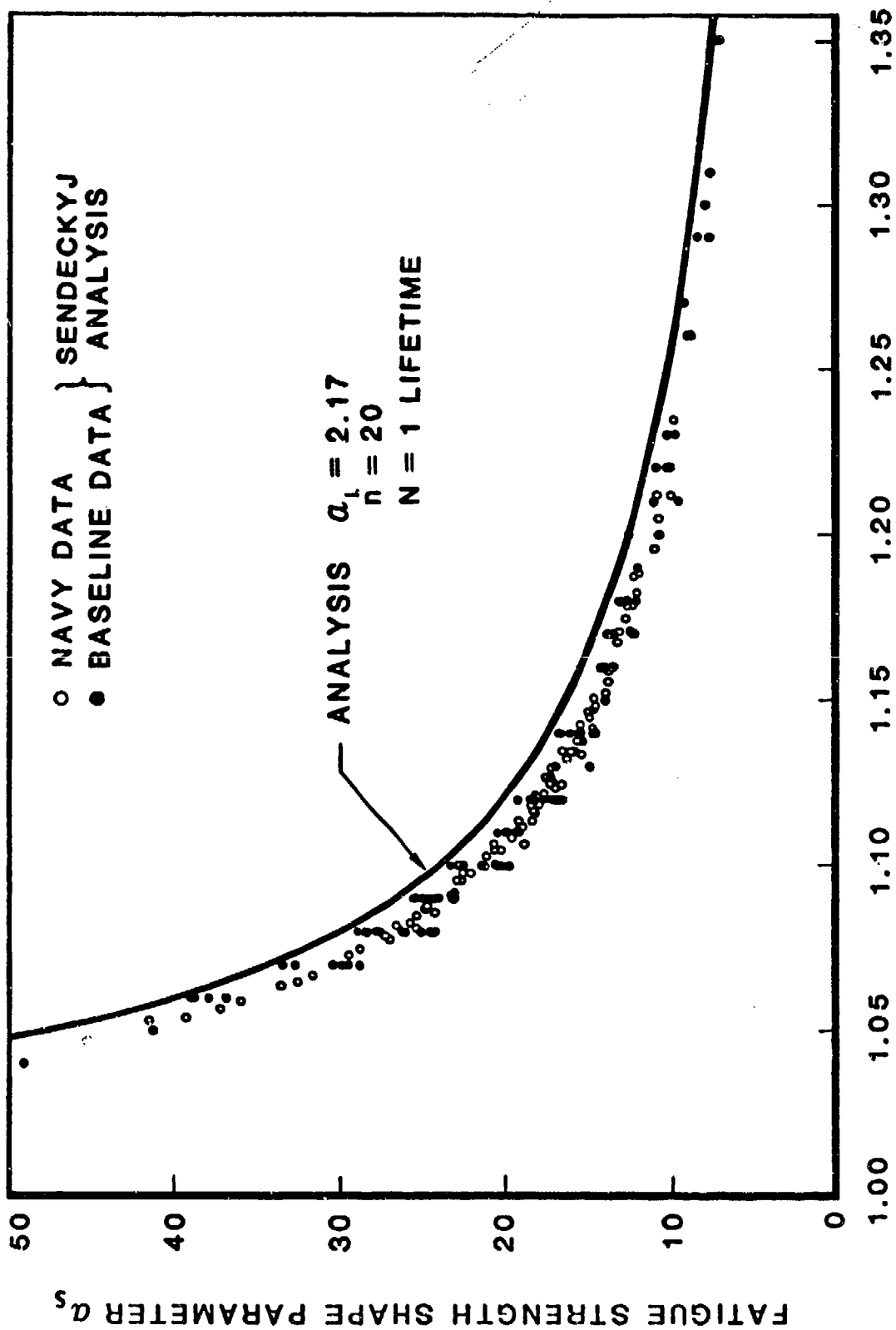

FIGURE 27. COMPARISON OF LOAD ENHANCEMENT FACTORS CALCULATED BY THE SENDECKYJ ANALYSIS WITH THEORETICAL VALUES.

2.3 Ultimate Strength Approach

The ultimate strength approach uses an increased static strength margin in conjunction with the fatigue threshold to demonstrate adequate fatigue life. This approach is conservative; however, if it is satisfied no fatigue test is necessary. The concept of a fatigue threshold in composites is shown in Figure 28. This figure shows typical composite fatigue behavior, where a fatigue threshold σ_{TH} exists at a relatively high proportion of the static strength. In order to use the ultimate static strength approach it is necessary to design structure such that the maximum spectrum design load (P_{MSL}) is no greater than B-basis fatigue threshold stress σ_{TH}^B . Thus

(19)

$$P_{MSL} \leq \sigma_{TH}^B$$

The relationship between maximum spectrum load (P_{MSL}) and design ultimate load (P_{DUL}) is a variable which depends on the spectrum type and shape (e.g., wing or tail). Thus we have

(20)

$$\frac{P_{MSL}}{P_{DUL}} = X$$

From Figure 28 we can define σ_{TH} and as follows:

(21)

$$\sigma_{TH}^M / \sigma_S^M = Y \quad \text{and} \quad \sigma_{TH}^B / \sigma_{TH}^M = Z$$

or

$$\sigma_{TH}^B = YZ \sigma_S^M \quad (22)$$

From equation (19) the requirement becomes

$$P_{MSL} \leq YZ \sigma_S^M \quad (23)$$

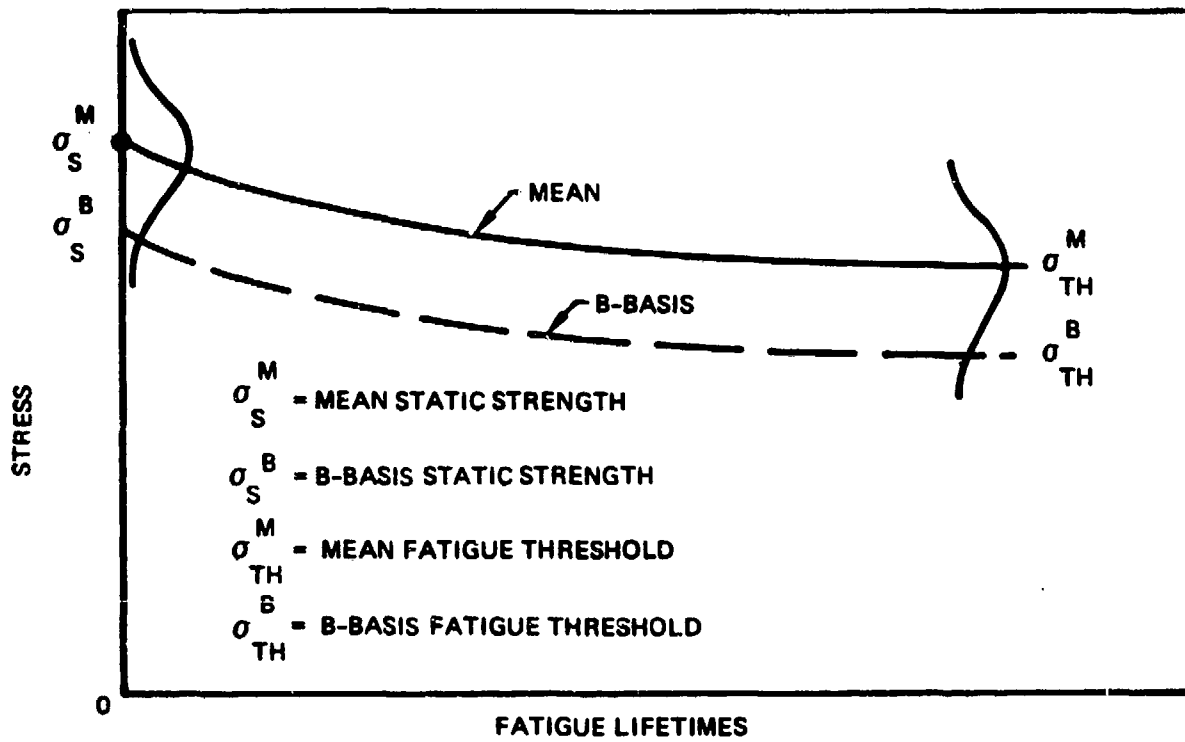

FIGURE 28. COMPOSITE FATIGUE LIFE THRESHOLD APPROACH.

or

$$P_{DUL} \leq \frac{YZ}{X} \sigma^M_S \quad (24)$$

In order to utilize this approach it is necessary to establish the relationship between the B-basis fatigue threshold and mean static strength. This ratio will be a function of the spectrum shape, failure mode and test environment.

The extensive fatigue data base in Reference 16 has been analyzed to determine the relationship between B-Basis fatigue threshold stress σ_{TH}^B and mean fatigue threshold stress σ_{TH}^M . For each S-N data set in Reference 16, the ratio of $\sigma_{TH}^B / \sigma_{TH}^M$ has been determined using the Sendekyj analysis. The influence of R-ratio and loading mode on this ratio were determined. In addition, the fatigue data scatter analysis conducted in Volume I is used to increase the $\sigma_{TH}^B / \sigma_{TH}^M$ data base. The total data base is then used to establish design knockdown factors for the determination of a B-basis fatigue life threshold from a mean fatigue life threshold. The results of this analysis are discussed below.

The equivalent static strength distribution determined by the Sendekyj analysis can be used to calculate the ratio of B-basis fatigue threshold σ_{TH}^B to mean fatigue life σ_{TH}^M . The relationship is

$$\frac{\sigma_{TH}^B}{\sigma_{TH}^M} = \frac{\sigma_e^B}{\sigma_e^M} = Z \quad (25)$$

The fatigue data in Reference 16 termed Navy data were analyzed using the Sendekyj analysis to determine values of the σ_e^B / σ_e^M ratio. Figure 29 shows the influence of R-ratio and loading mode on the B-basis/mean life fatigue threshold ratio σ_e^B / σ_e^M . It can be seen that R-ratio has a small influence on this life ratio. $R = -1$ loading shows the lowest B-basis/mean life threshold ratio. However, the influence of R-ratio is

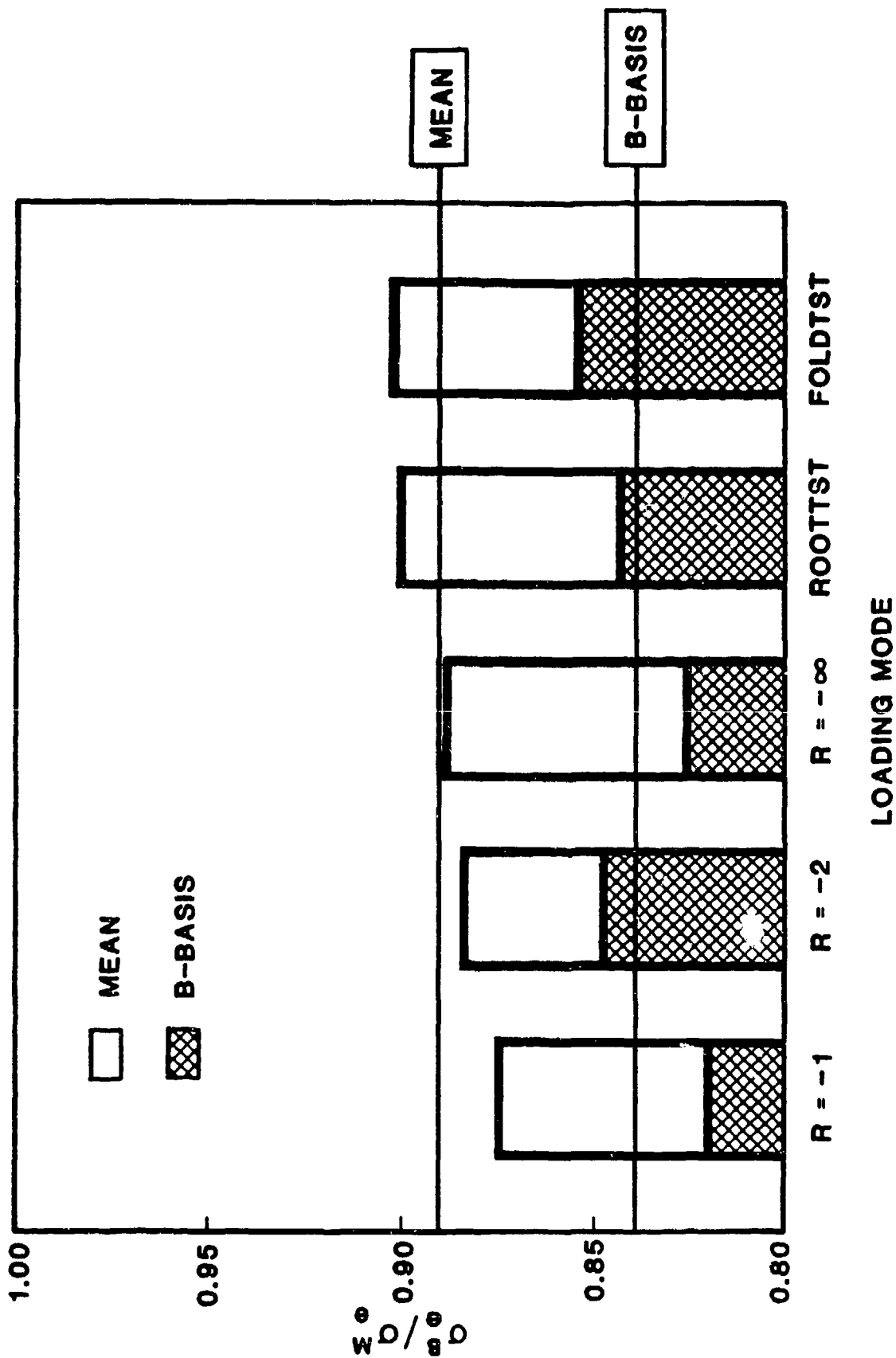

FIGURE 29. INFLUENCE OF LOADING MODE ON THE B-BASIS TO MEAN LIFE FATIGUE THRESHOLD RATIO, σ_e^B / σ_e^M .

different for the B-basis value of the σ_e^B/σ_e^M ratio. Figures 29 and 30 show that the spectrum loading σ_e^B/σ_e^M ratios are slightly higher than for constant amplitude loading. The observed differences in the σ_e^B/σ_e^M ratio in Figures 29 and 30 are not statistically significant. Thus the values of σ_e^B/σ_e^M from the Navy data set were pooled for statistical analysis. The results are presented in Figure 31, which shows that a modal σ_e^B/σ_e^M value equal to 0.895 was obtained.

The extensive data base in Reference 15 was also used to determine σ_e^B/σ_e^M values through the Sendekyj analysis. The determined σ_e^B/σ_e^M values are also pooled for statistical analysis. The results are presented in Figure 32, which show that the modal value of σ_e^B/σ_e^M is equal to 0.905. A comparison of the σ_e^B/σ_e^M distributions for the Navy and Baseline data sets is shown in Figure 33. It can be seen that the distributions are similar; however, the Baseline data set exhibits a larger spread in σ_e^B/σ_e^M values. This was anticipated because the Baseline data set contained a wider range of materials, lay-ups and test conditions.

Figure 34 shows analysis results for the combined σ_e^B/σ_e^M data set (Baseline and Navy data pooled). The modal value of σ_e^B/σ_e^M is equal to 0.895 for the combined data set. Table 1 summarizes the analysis results for the Navy, Baseline and combined data sets.

Following the philosophy adopted for static strength and fatigue life scatter, the modal value of σ_e^B/σ_e^M equal to 0.895 will be used for evaluation of the ultimate strength certification approach.

In order to utilize the ultimate strength approach it is also necessary to determine the ratio of the mean fatigue threshold σ_{TH}^M to the mean static strength σ_S^M . The extensive fatigue data in Reference 16 are used to determine the influence of R-ratio, upper wing skin spectrum loading and specimen geometry on the ratio σ_{TH}^M/σ_S^M . Figures 35 through 37 show the influence of R-ratio and spectrum loading on the σ_{TH}^M/σ_S^M ratio

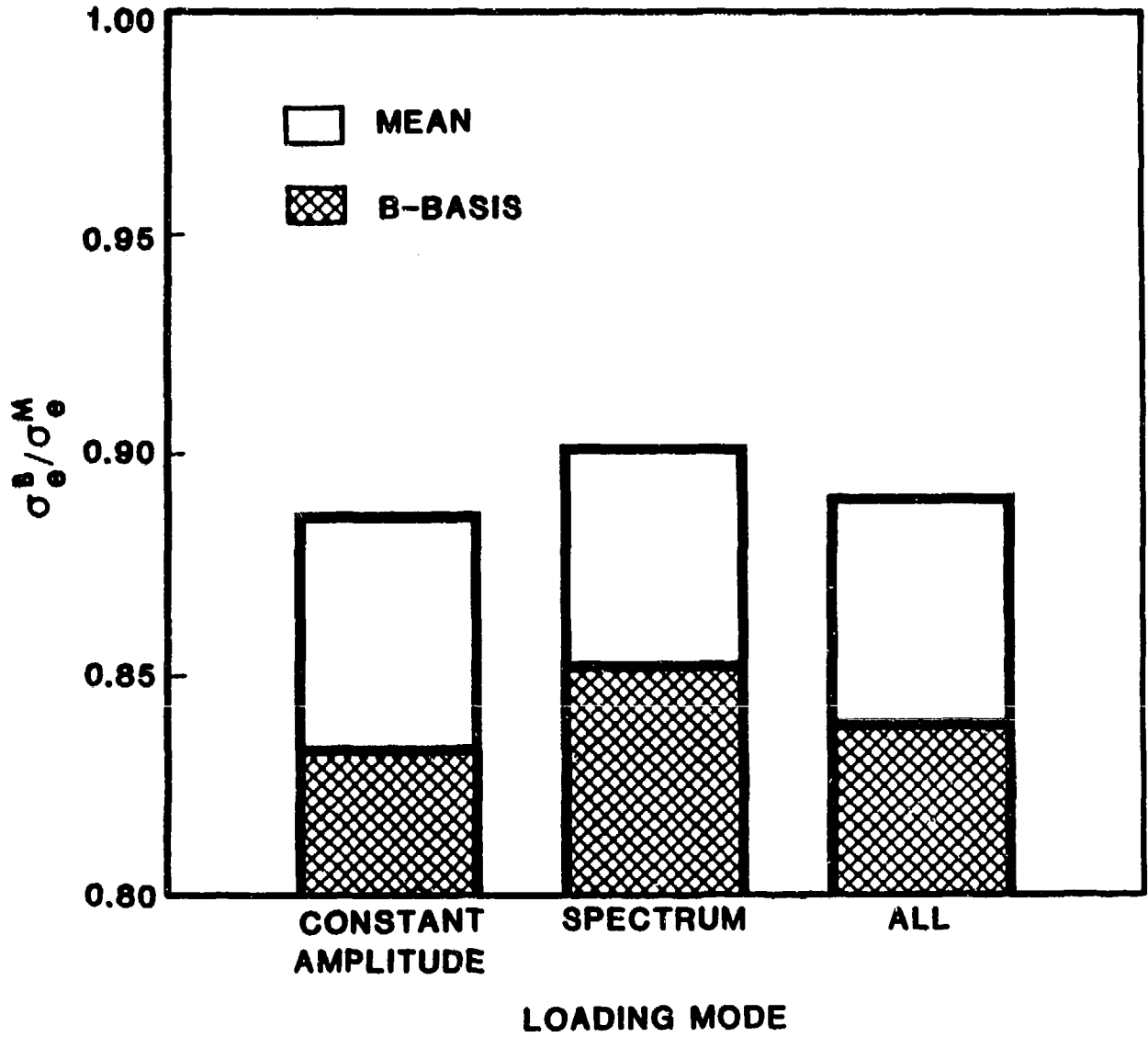
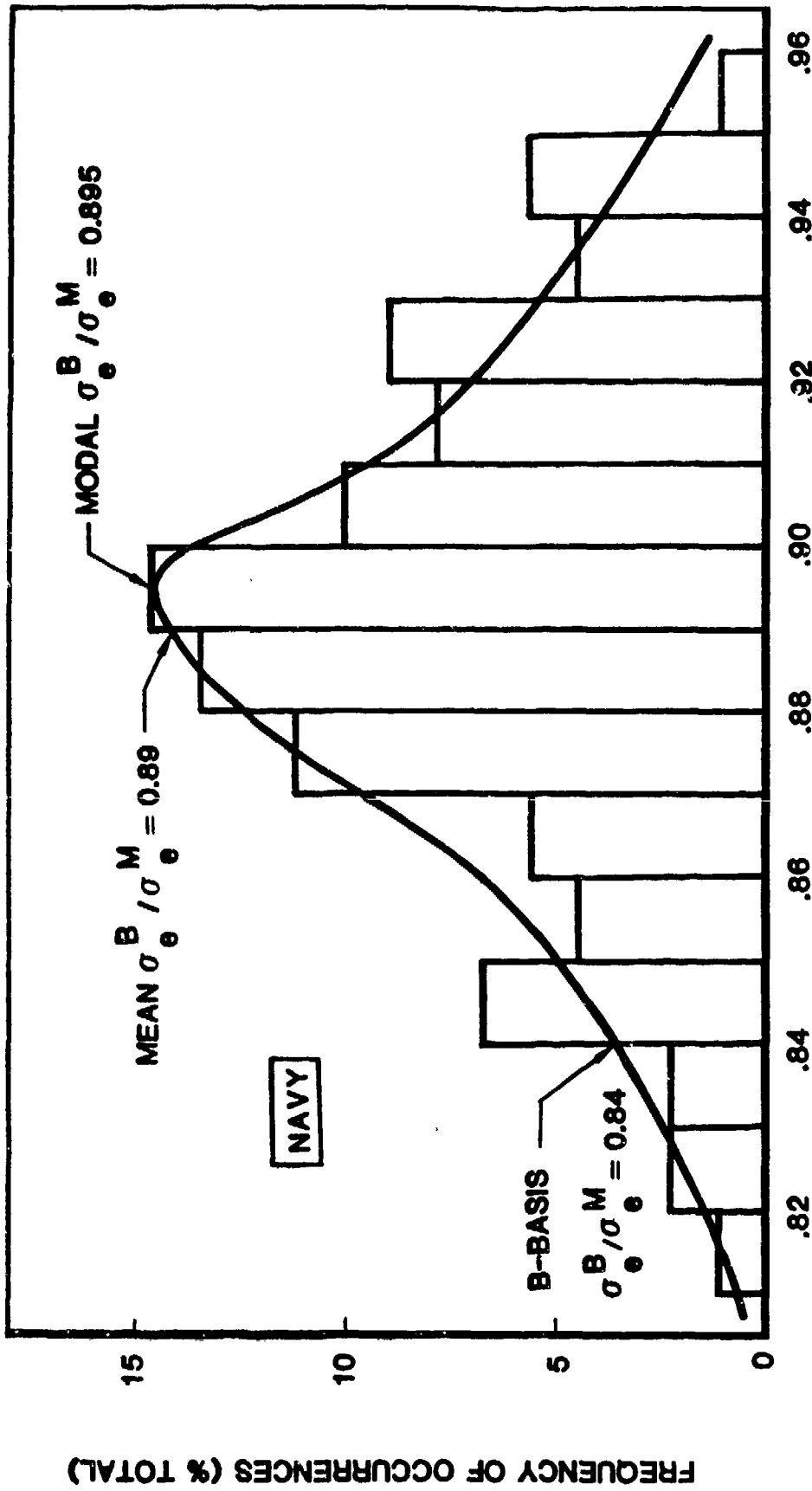

FIGURE 30. INFLUENCE OF LOADING MODE ON THE B-BASIS TO MEAN LIFE FATIGUE THRESHOLD RATIO, σ_e^B / σ_e^M .



RATIO OF B-BASIS TO MEAN FATIGUE LIFE THRESHOLD

FIGURE 31. DISTRIBUTION OF B-BASIS TO MEAN FATIGUE LIFE THRESHOLDS FOR NAVY DATA.

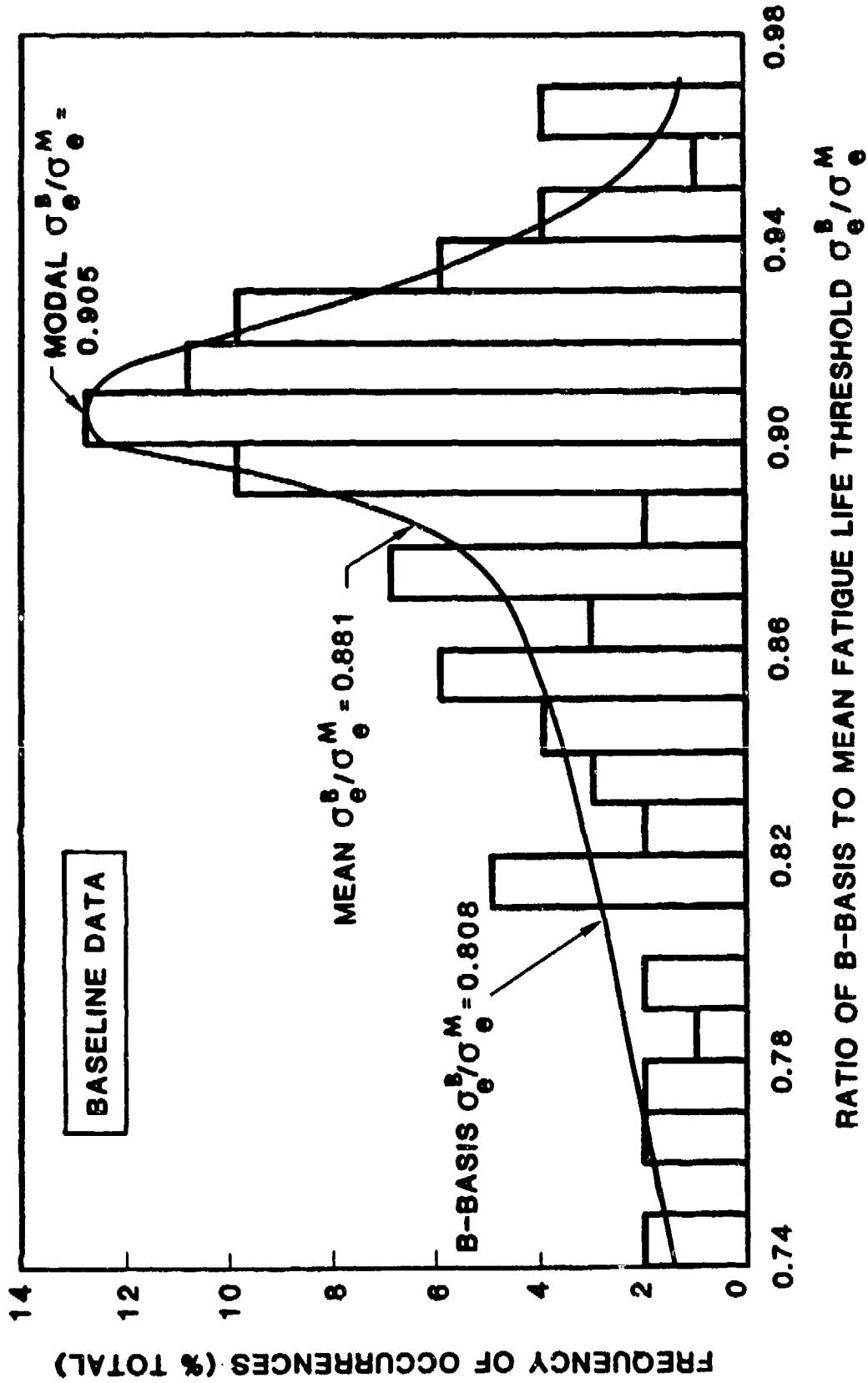

FIGURE 32. DISTRIBUTION OF B-BASIS TO MEAN FATIGUE LIFE THRESHOLDS FOR BASELINE DATA.

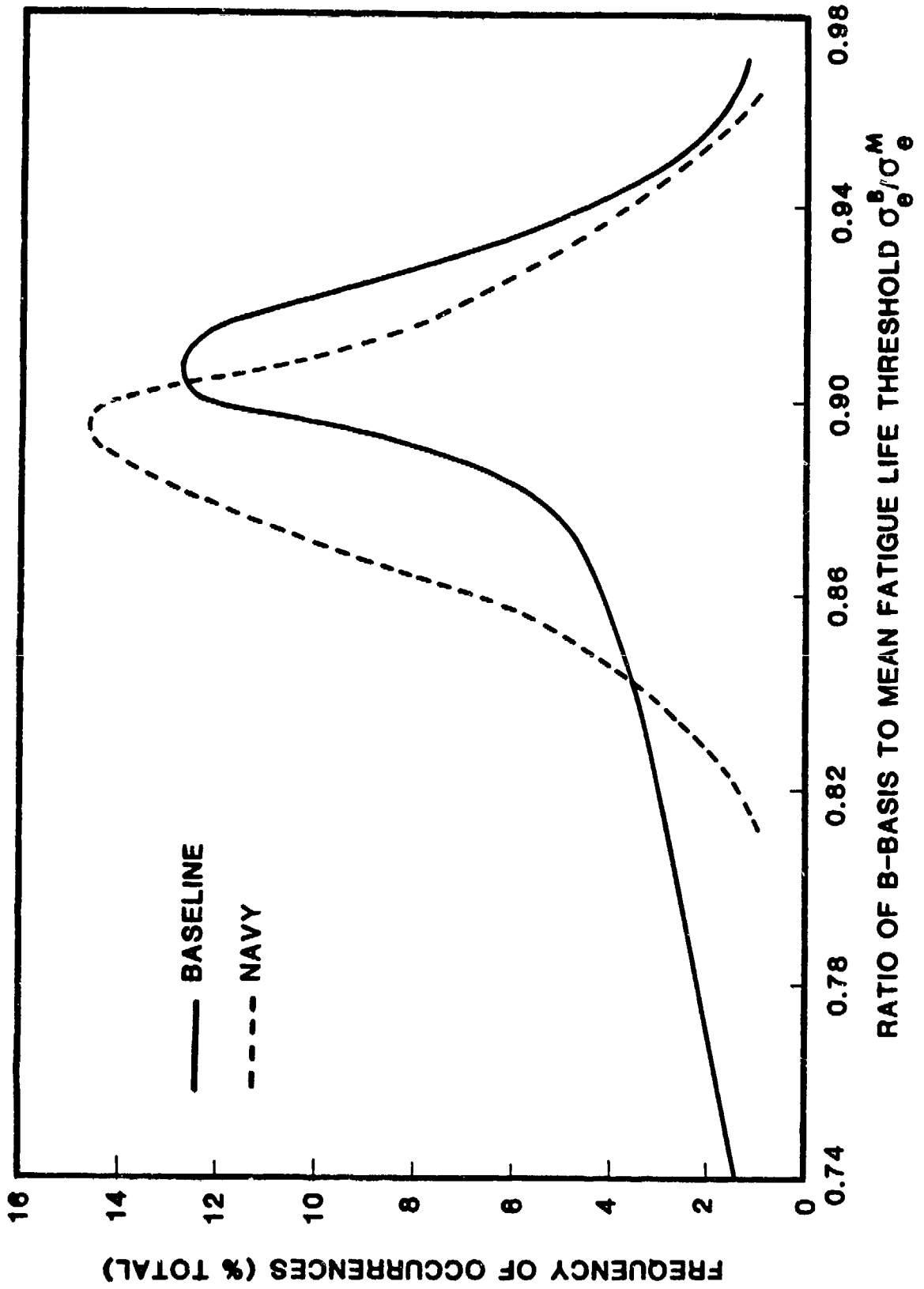

FIGURE 33. COMPARISON OF NAVY AND BASELINE B-BASIS TO MEAN FATIGUE LIFE THRESHOLD DISTRIBUTIONS.

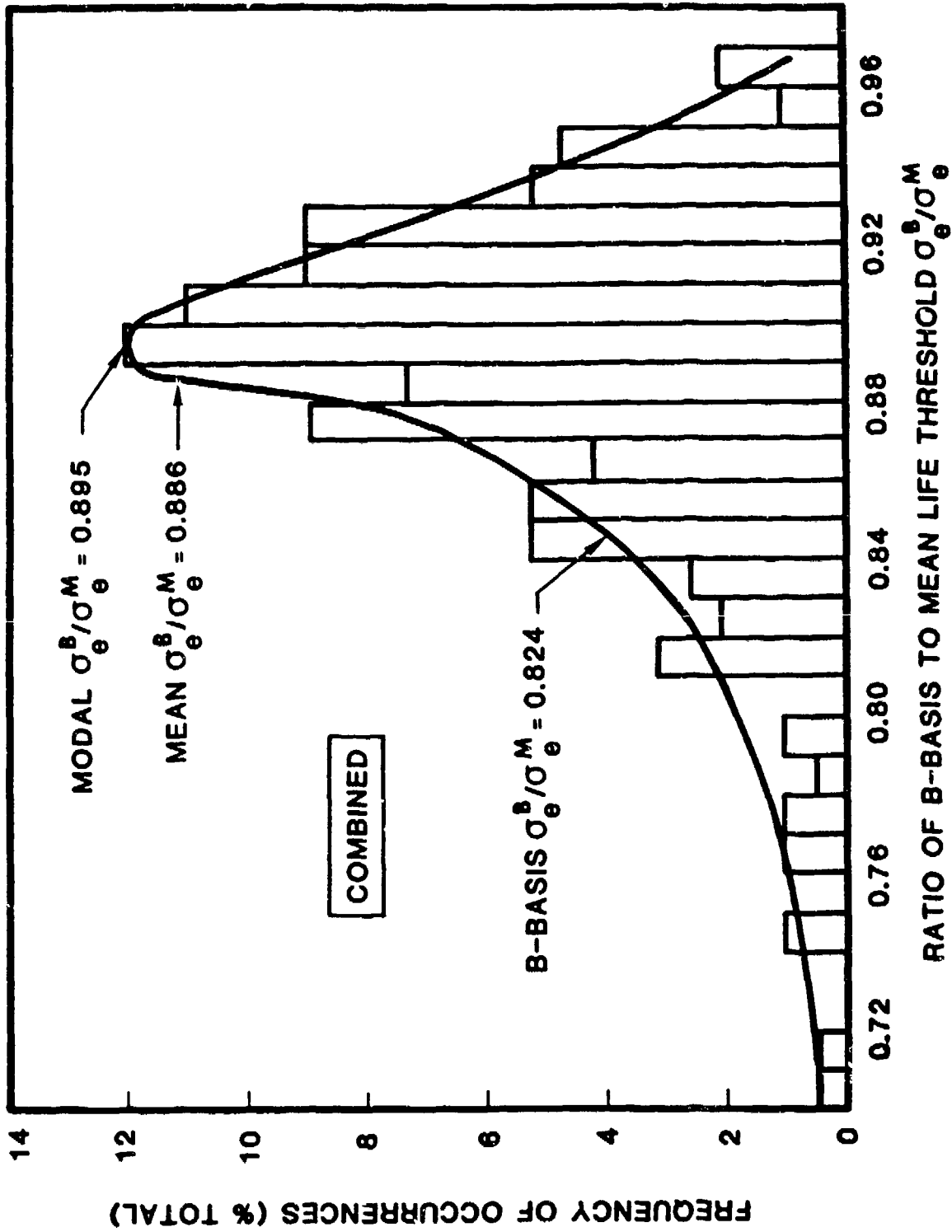

FIGURE 34. DISTRIBUTION OF B-BASIS TO MEAN FATIGUE LIFE THRESHOLDS FOR COMBINED DATA.

TABLE 1. SUMMARY OF THE STATISTICAL ANALYSIS OF THE B-BASIS TO MEAN FATIGUE LIFE THRESHOLD RATIO VALUES.

DATA SET	B-BASIS/MEAN FATIGUE LIFE THRESHOLD σ_e^B / σ_e^M		
	MEAN	MODAL	B-BASIS
NAVY	0.890	0.895	0.840
BASELINE	0.891	0.905	0.833
COMBINED	0.886	0.895	0.824

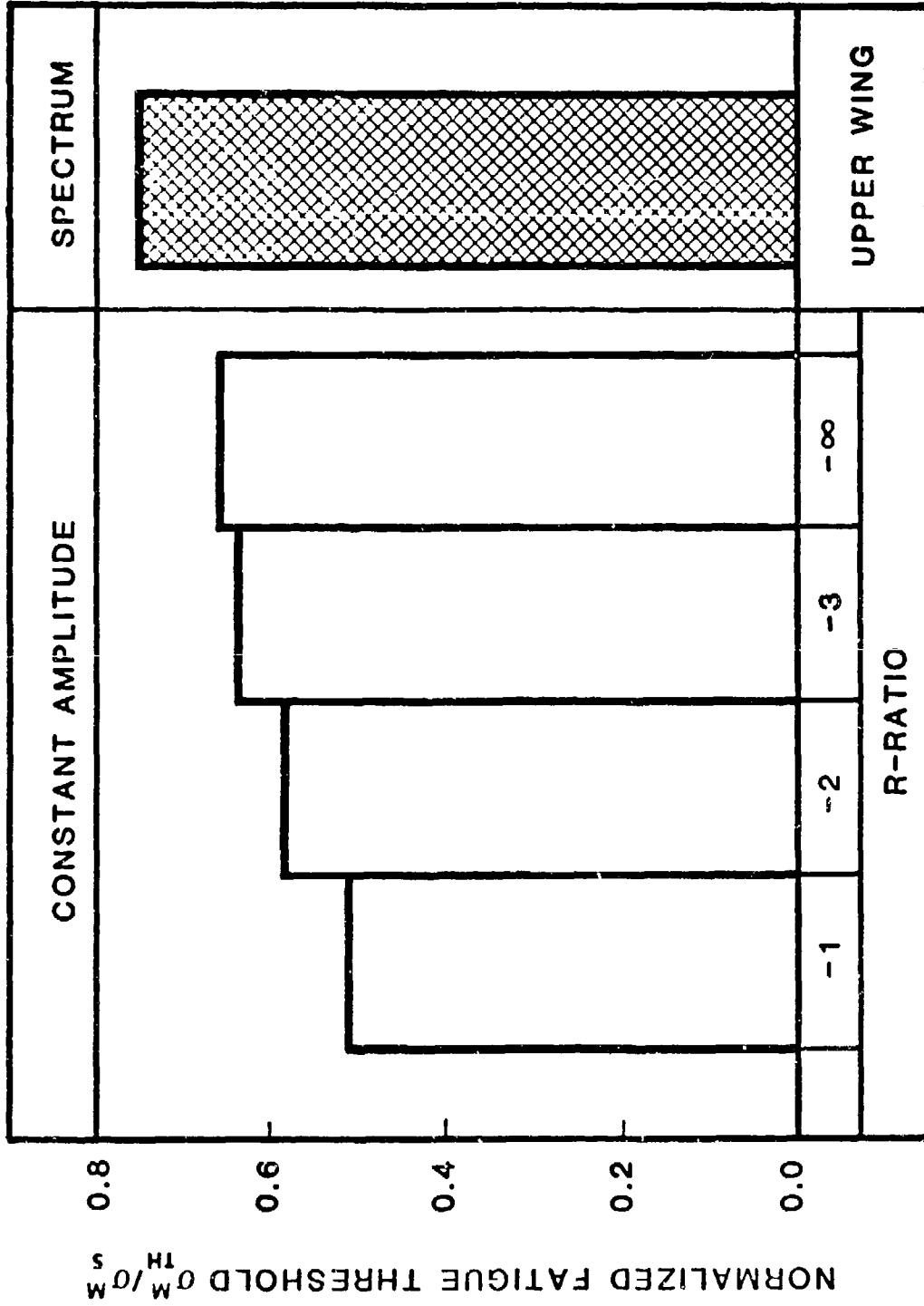

FIGURE 35. INFLUENCE OF FATIGUE LOADING MODE ON NORMALIZED FATIGUE THRESHOLD FOR INTERMEDIATE LOAD TRANSFER SPECIMENS IN REFERENCE 16.

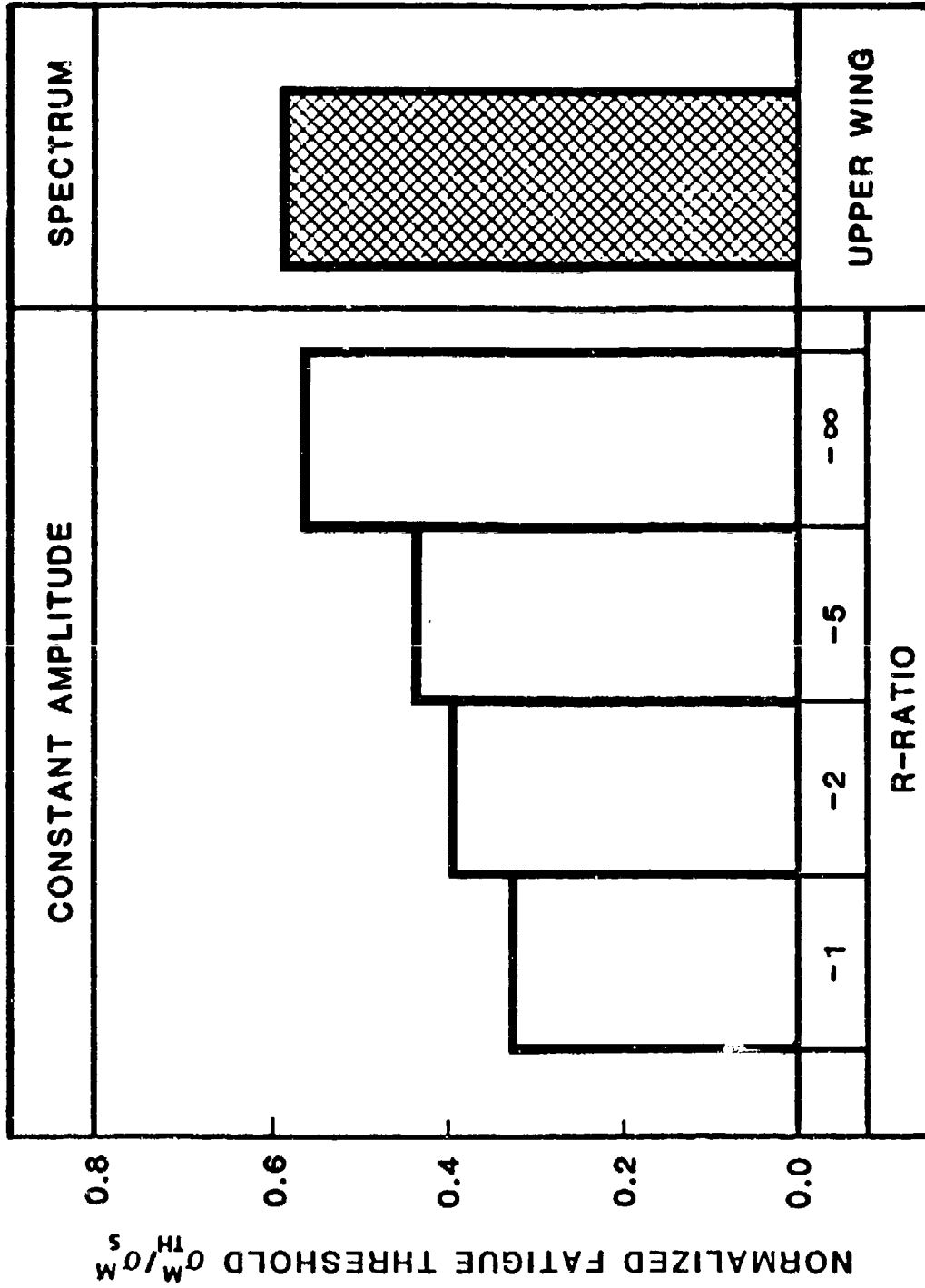

FIGURE 36. INFLUENCE OF FATIGUE LOADING MODE ON NORMALIZED FATIGUE THRESHOLD FOR HIGH LOAD TRANSFER SPECIMENS IN REFERENCE 16.

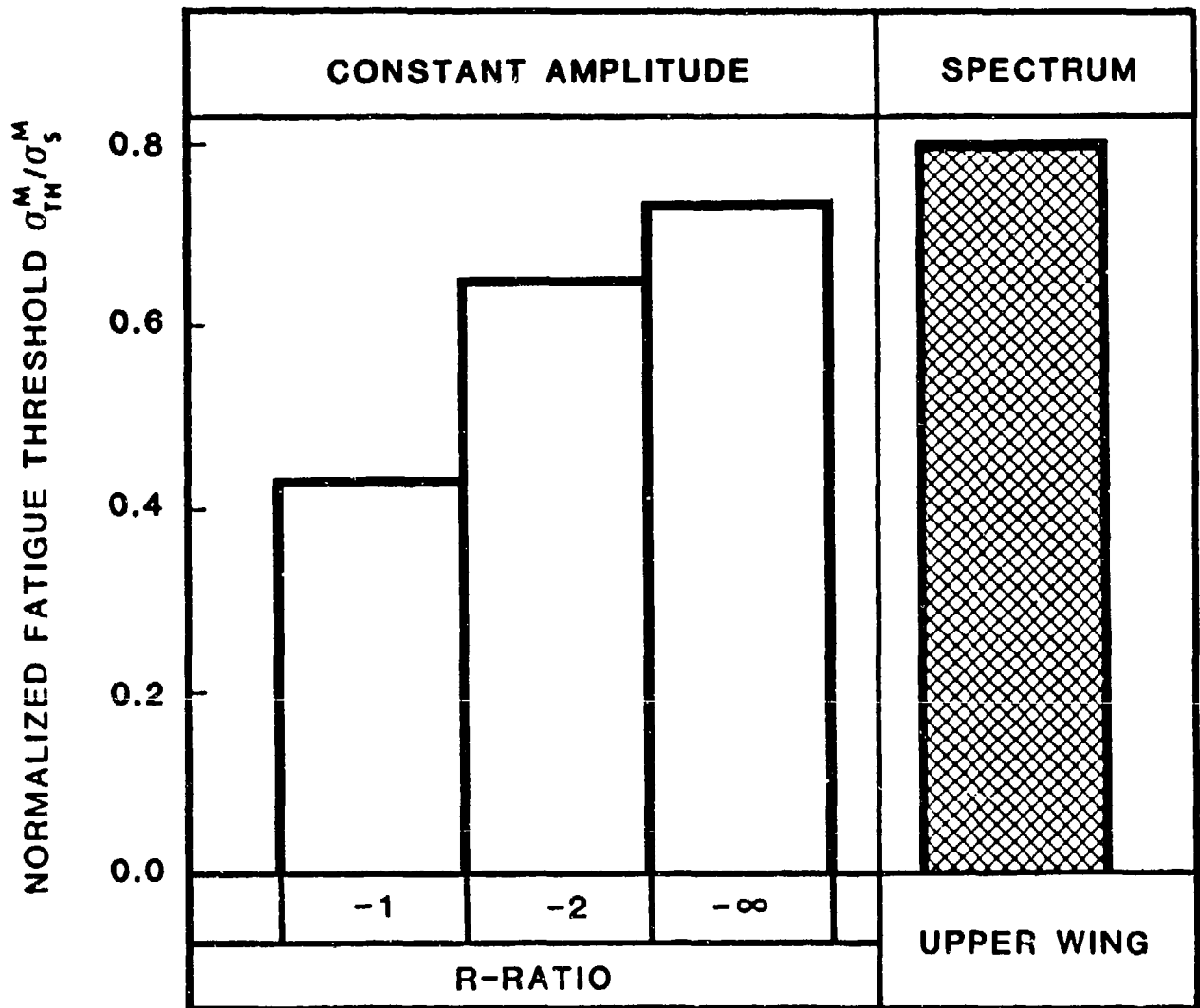

FIGURE 37. INFLUENCE OF FATIGUE LOADING MODE ON NORMALIZED FATIGUE THRESHOLD FOR COMPLEX SPECIMENS IN REFERENCE 16.

for three joint types. The data for all three joint types show a similar trend. As R-ratio increases from -1 to $-\infty$ the threshold ratio increases; however, spectrum fatigue threshold ratios are higher than those determined for constant amplitude loading. Thus, it can be concluded that fatigue testing under constant amplitude loading is conservative relative to upper wing skin spectrum fatigue loading. The data for the three joints are pooled and the results are shown in Figure 38. As expected, the pooled data show the same influences of R-ratio and spectrum loading.

The spectrum fatigue loading data in Reference 16 are analyzed in more detail because of its relevance to certification testing. The influence of joint geometry, lay-up, spectrum loading type and test environment are presented in Table 2 and Figure 39. Twenty-three spectrum loading S-N curves are used in the analysis. The results show that high load transfer specimens had lower normalized fatigue threshold than intermediate load transfer and complex specimens. This is probably due to the different failure mode observed in the high load transfer specimens, which was hole wear. The normalized fatigue threshold for these specimens is based on 0.025 inch hole wear, which probably gives a conservative estimate of the fatigue threshold. Figure 39 also shows that the decreasing laminate stiffness lowers the normalized fatigue threshold value. This reflects the higher fatigue sensitivity of the (16/80/4) lay-up. The influence of spectrum loading type on normalized fatigue thresholds is shown to be negligible in Figure 39. This suggests that composite spectrum fatigue life is dominated by the peak compression load and is relatively independent of load reversal severity. Table 2 shows that the normalized fatigue threshold is higher for the ETW environment relative to the RTD environment. This implies that the fatigue degradation rate relative to static strength is lower in the ETW environment. The overall mean value of the normalized fatigue threshold for spectrum loading is determined to be 0.71. This value and the scatter analyses for $\sigma_{TH}^B/\sigma_{TH}^M$ (described earlier) and for $\sigma_{TH}^M/\sigma_{TH}^S$ are used to determine the fatigue threshold

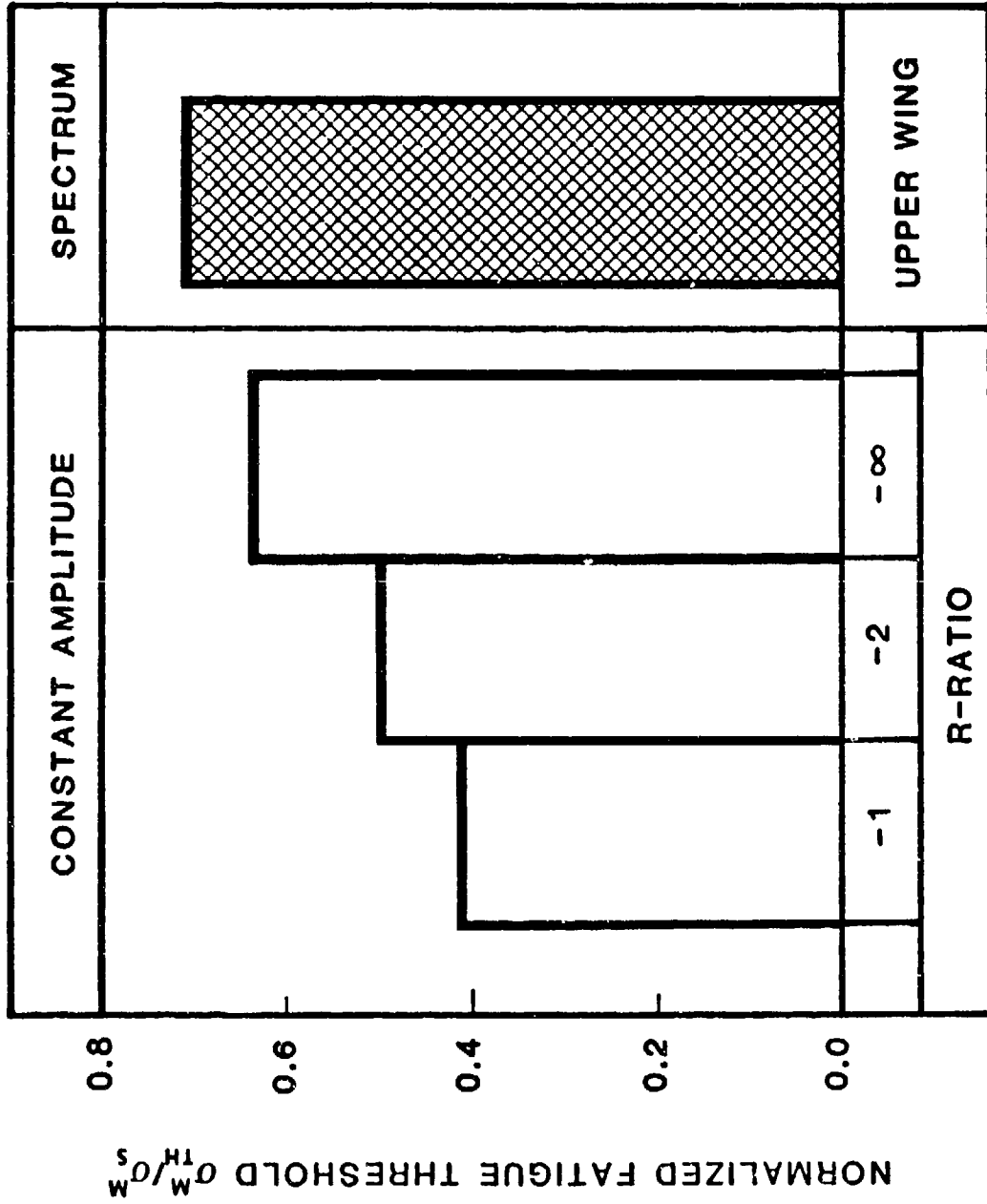

FIGURE 38. INFLUENCE OF FATIGUE LOADING MODE ON NORMALIZED FATIGUE THRESHOLD FOR ALL SPECIMENS IN REFERENCE 16.

TABLE 2. INFLUENCE OF TEST VARIABLES ON NORMALIZED FATIGUE THRESHOLDS UNDER SPECTRUM LOADING.

COMPARISON	NORMALIZED FATIGUE THRESHOLD
	$\sigma_{TH}^M / \sigma_S^M$
ROOTTST	0.72
FOLDTST	0.70
INT. L/T	0.75
HIGH L/T	0.59
COMPLEX	0.80
(48/48/4)	0.83
(16/80/4)	0.67
RTD	0.66
ETW	0.75
OVERALL MEAN	0.71

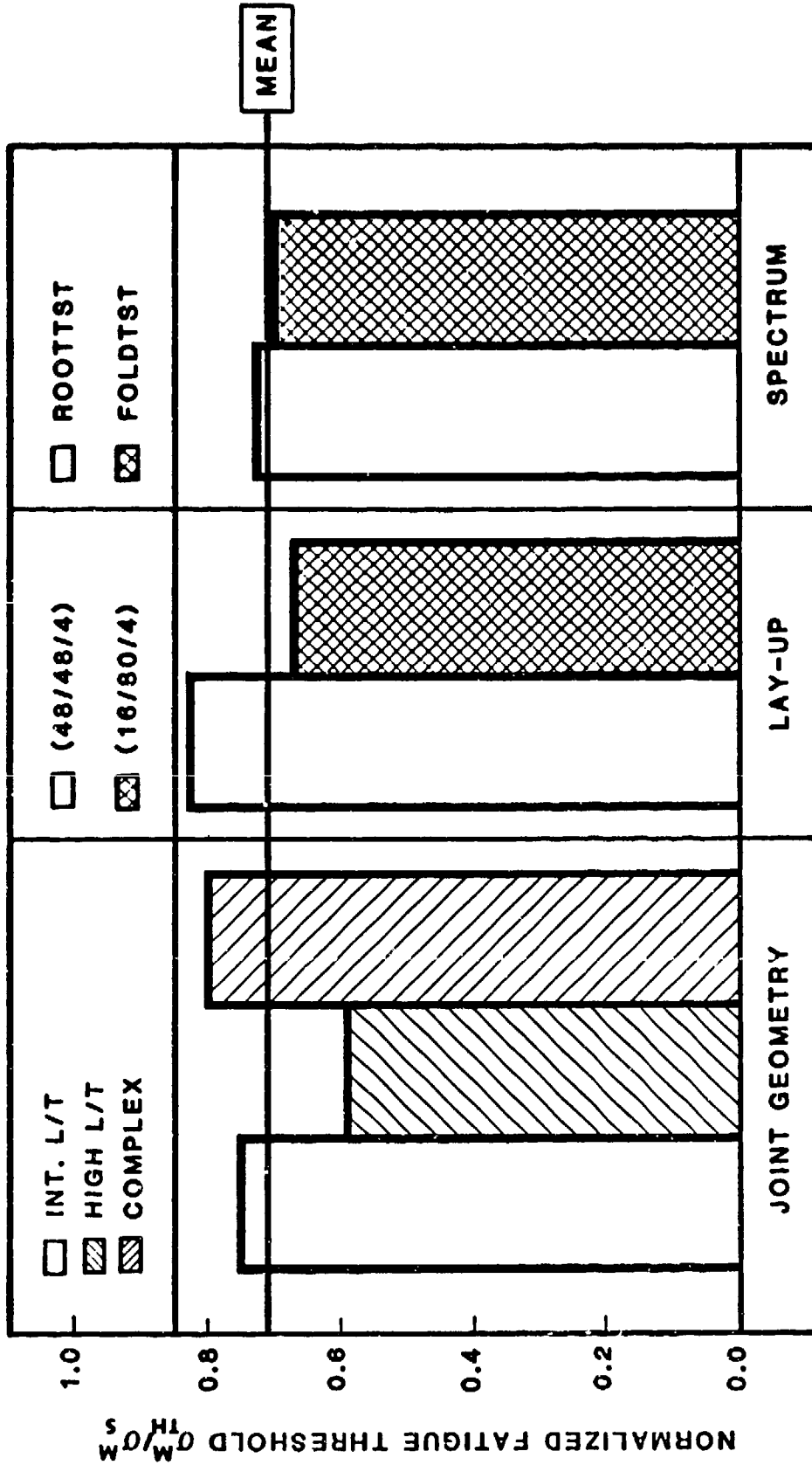

FIGURE 39. INFLUENCE OF JOINT GEOMETRY, LAY-UP AND SPECTRUM TYPE ON NORMALIZED FATIGUE THRESHOLDS FOR SPECTRUM LOADING.

behavior for upper wing spectrum loading. The results are shown in Figure 40. The B-basis fatigue threshold is determined to be 63 percent of the mean static strength. That is, if the maximum spectrum load is set to ≤ 63 percent of the mean static strength a B-basis fatigue threshold will be established statistically.

Once σ_{TH}^M and σ_{TH}^B have been established statistically, as in Figure 40, the static failure load required to guarantee a B-basis fatigue threshold (no fatigue test) is calculated as follows:

No fatigue test is required if:

$$\text{Static Failure Load} = \sigma_S^M \geq \left(\frac{P_{MSL}}{P_{DUL}} \cdot \frac{\sigma_S^M}{\sigma_{TH}^M} \cdot \frac{\sigma_{TH}^M}{\sigma_{TH}^B} \right) \cdot P_{DUL}$$

Example calculations for RTD test conditions, a (48/48/4) laminate and F-18 upper wing spectrum, are presented in Table 3. The calculations show that the static failure load requirements for no fatigue test range from 122 percent to 187 percent of design ultimate load.

The influence of spectrum type on the static failure load for B-basis fatigue reliability is shown in Figure 41. These data show that the static failure load requirement ranges from 78 percent to 129 percent DUL. The significant differences in the static overload requirements for the three spectra are caused mainly by the significant differences in their P_{MSL}/P_{DUL} ratios. These are:

SPECTRUM TYPE	P_{MSL}/P_{DUL}
VERTICAL	0.489
HORIZONTAL	0.651
WING	0.814

It should be noted that the σ_{TH}^M/σ_S^M values used for the calculations shown in Figure 41 were typical values. Figure 41 is not, therefore, a design chart.

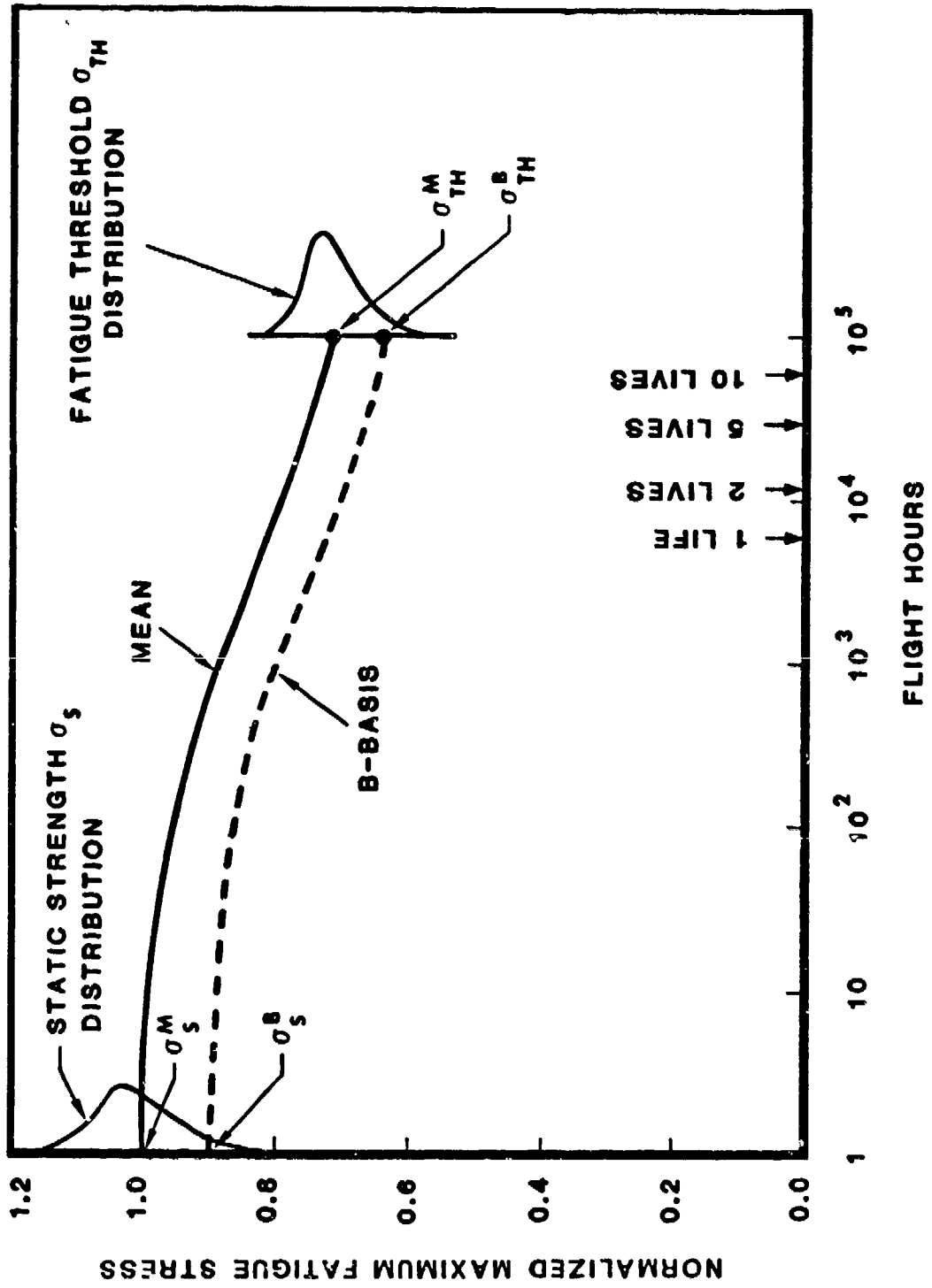

FIGURE 40. STATISTICAL FATIGUE THRESHOLD FOR UPPER WING SKIN SPECTRUM LOADING.

TABLE 3. STATIC FAILURE LOAD REQUIREMENTS FOR NO FATIGUE TEST OF A (48/48/4) LAMINATE IN A RTD ENVIRONMENT.

SPECTRUM	SPECIMEN	$\frac{P_{MSL}}{P_{DUL}}$	$\frac{\sigma_{MTH}}{\sigma_{MS}}$	$\frac{\sigma_{BTH}}{\sigma_{MTH}}$	STATIC FAILURE LOAD REQUIREMENT % DUL
ROOTTST	OPEN HOLE	} 0.84	0.78	} 0.885	122
	INT. L/T		0.76		125
	HIGH L/T		0.67		142
FOLDTST	OPEN HOLE	} 0.894	0.82	} 0.885	123
	INT. L/T		0.54		187
	COMPLEX		0.84		120

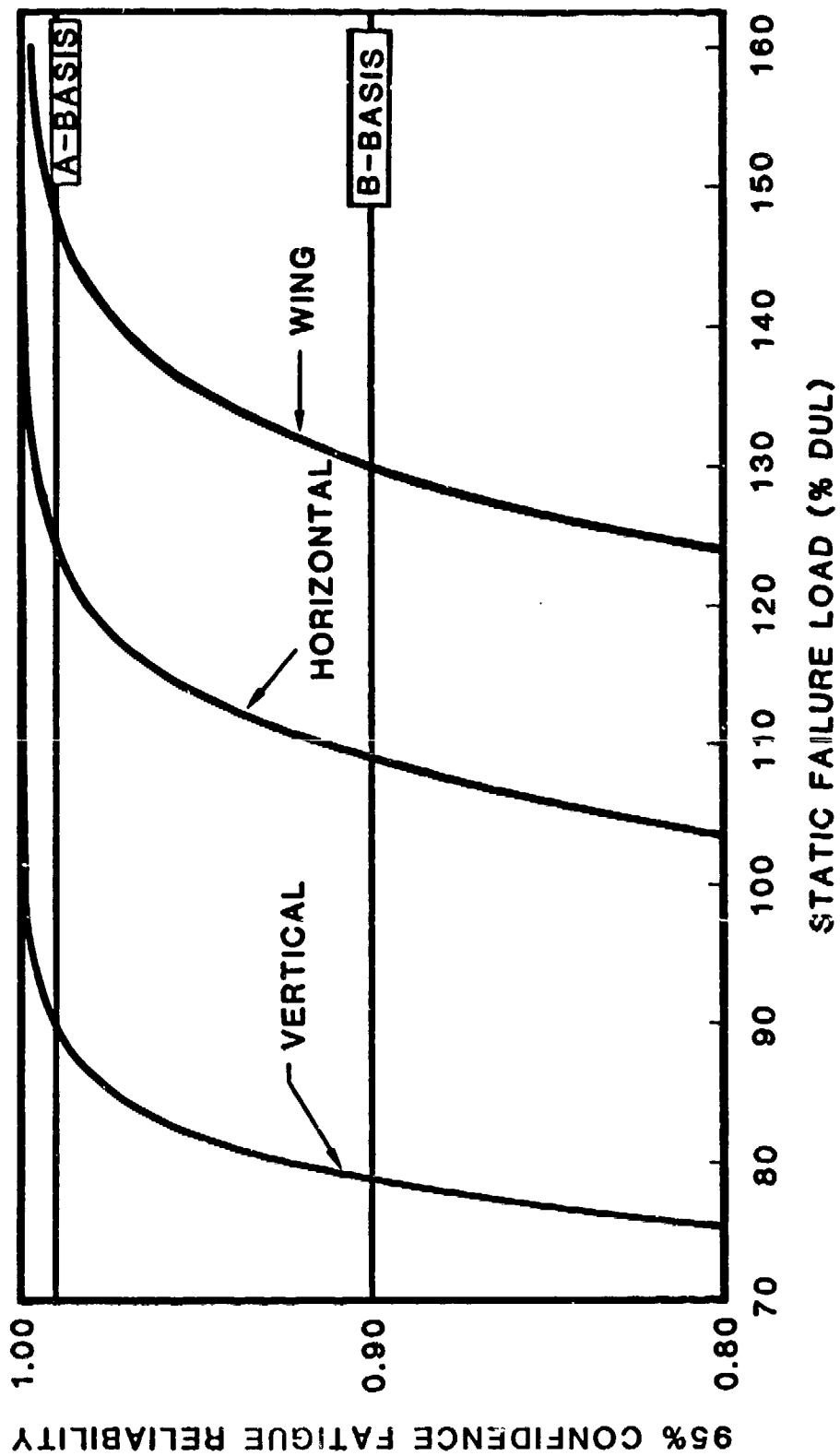

FIGURE 41. INFLUENCE OF SPECTRUM TYPE ON STATIC OVERLOAD REQUIREMENT FOR B-BASIS FATIGUE RELIABILITY.

2.4 Change in Spectrum Approach

The problem of mixed composite/metal fatigue testing was summarized in October 1981 by Dr. Someroff of NAVAIR. Figure 42 presents his concern, which was that a two lifetime test did not adequately interrogate composite parts for potential hot-spots. This occurred because composites had considerably higher average fatigue lives and exhibit higher life scatter than metals. Someroff suggested changing the test spectrum to reduce composite fatigue life, while maintaining metal fatigue life constant. The ultimate aim would be to make the B-basis stress-life plots overlap for both materials. In principle, this can be accomplished by adding extra high loads to the fatigue spectrum. These loads could significantly reduce composite fatigue life, but maintain metal fatigue life at a constant value because the increased damage accumulation could be cancelled out by increased retardation effects in the metal parts.

The practical situation for mixed structures is more complex than envisaged by Someroff, as shown in Figure 43. Someroff assumed in Figure 42 that the stress-life curves for metals and composites had approximately the same slope. However, Figure 43 shows that this is not the case. Composites have considerably flatter S-N curves. This makes the change in spectrum approach more difficult to apply. The data in Figure 43 are shown for an F-18 wing root spectrum. For each material, sensitivity to the most critical spectrum is shown; that is, compression dominated for composites and tension dominated for metals. Figure 44 shows that this characteristic difference exists for three widely different spectrum types. The curves shown in Figure 44 are analytical. A comparison of the three spectra is shown in Figure 45. All analytical predictions were made using the methods described in References 17 through 19.

Figure 46 shows the influence of overloads on composite fatigue life for an F-18 wing root spectrum. Spectrum overloads in the range 110-120 percent of the maximum spectrum load were selected, with occurrences of these loads ranging 10 to 100 per

LONG LIFE and HIGH VARIABILITY ... POSE TESTING PROBLEMS

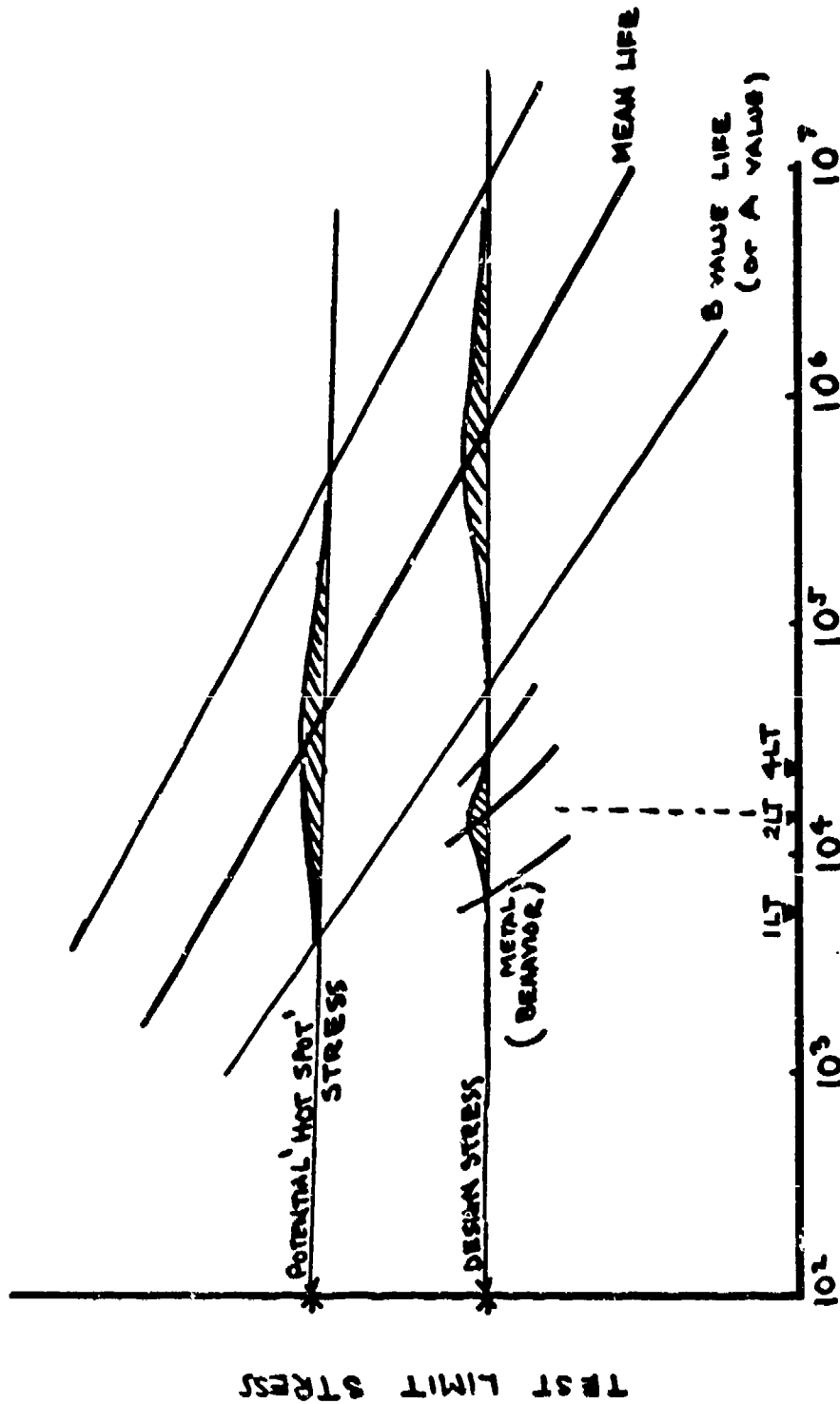

FIGURE 42. SCHEMATIC SUMMARY OF MIXED STRUCTURE TESTING PROBLEMS
(A. SOMEROFF NAVAIR, OCTOBER 1981).

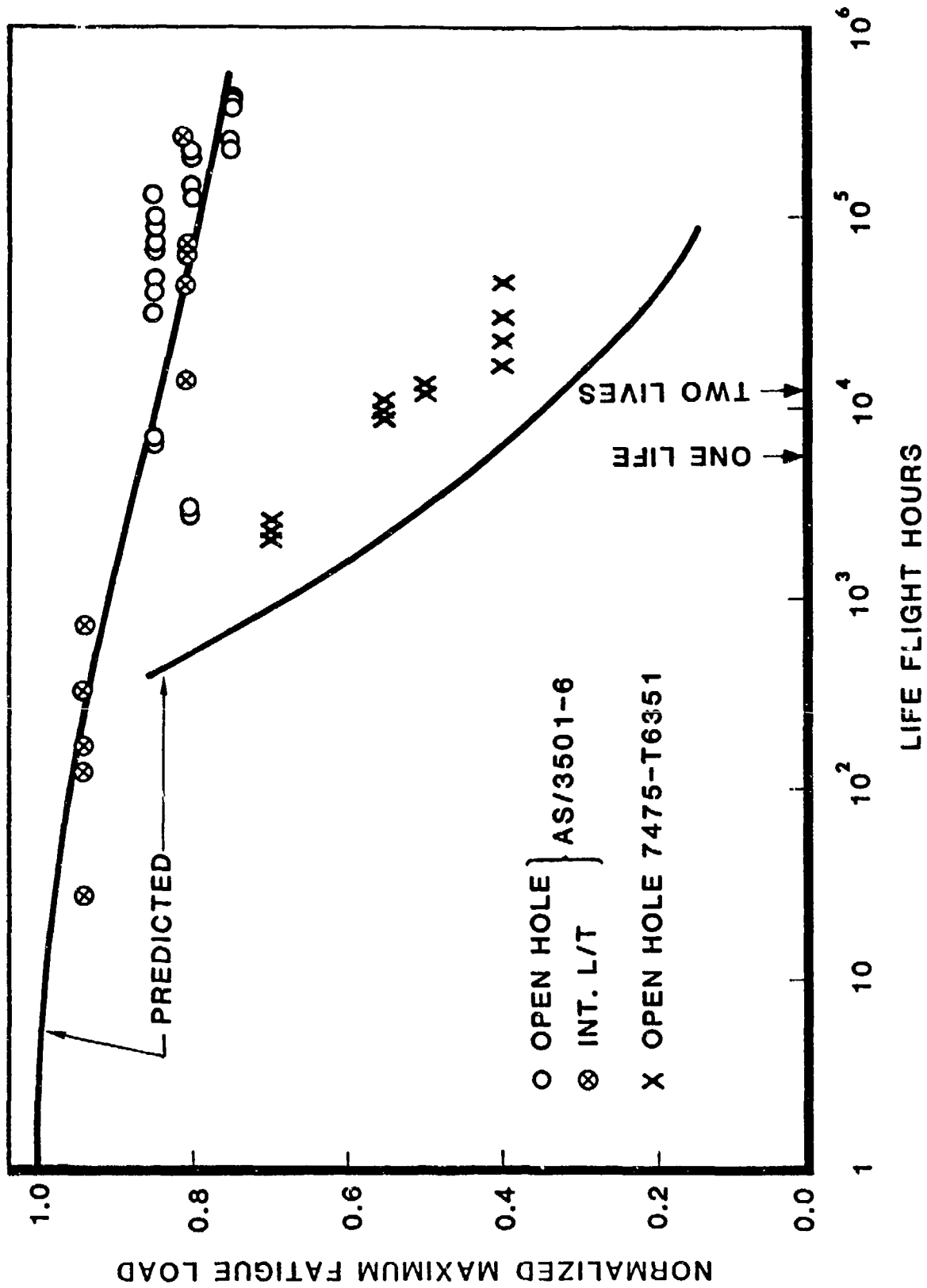

FIGURE 43. COMPARISON OF COMPOSITE AND METALLIC FATIGUE SPECTRUM FATIGUE BEHAVIOR FOR A WING SPECTRUM.

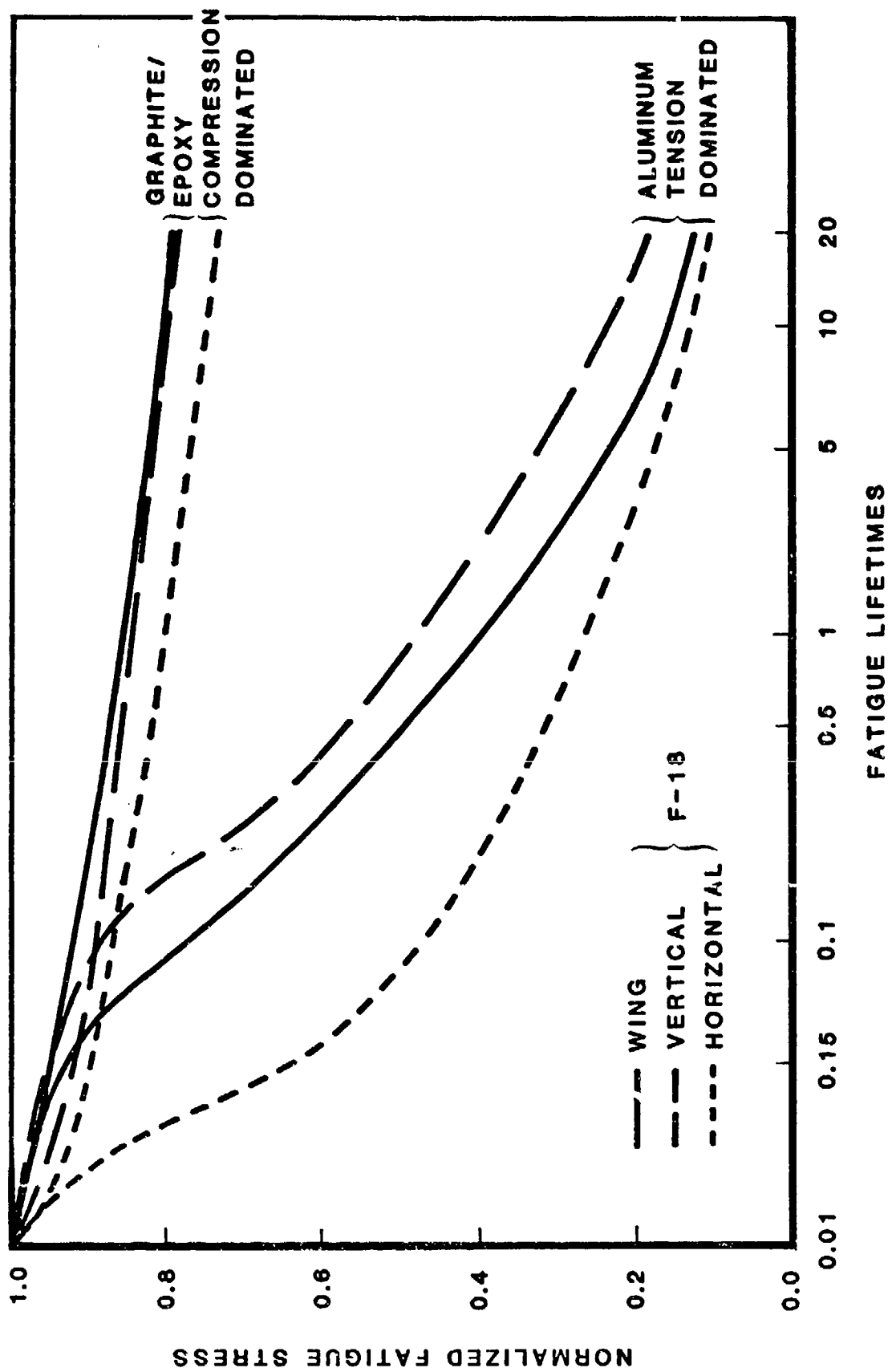

FIGURE 44. INFLUENCE OF SPECTRUM TYPE ON PREDICTED COMPOSITE AND METAL FATIGUE LIFE.

- WING (100% = 1.223 x DLL)
- - - FIN (100% = 0.773 DUL)
- HORIZONTAL (100% = 0.977 DLL)

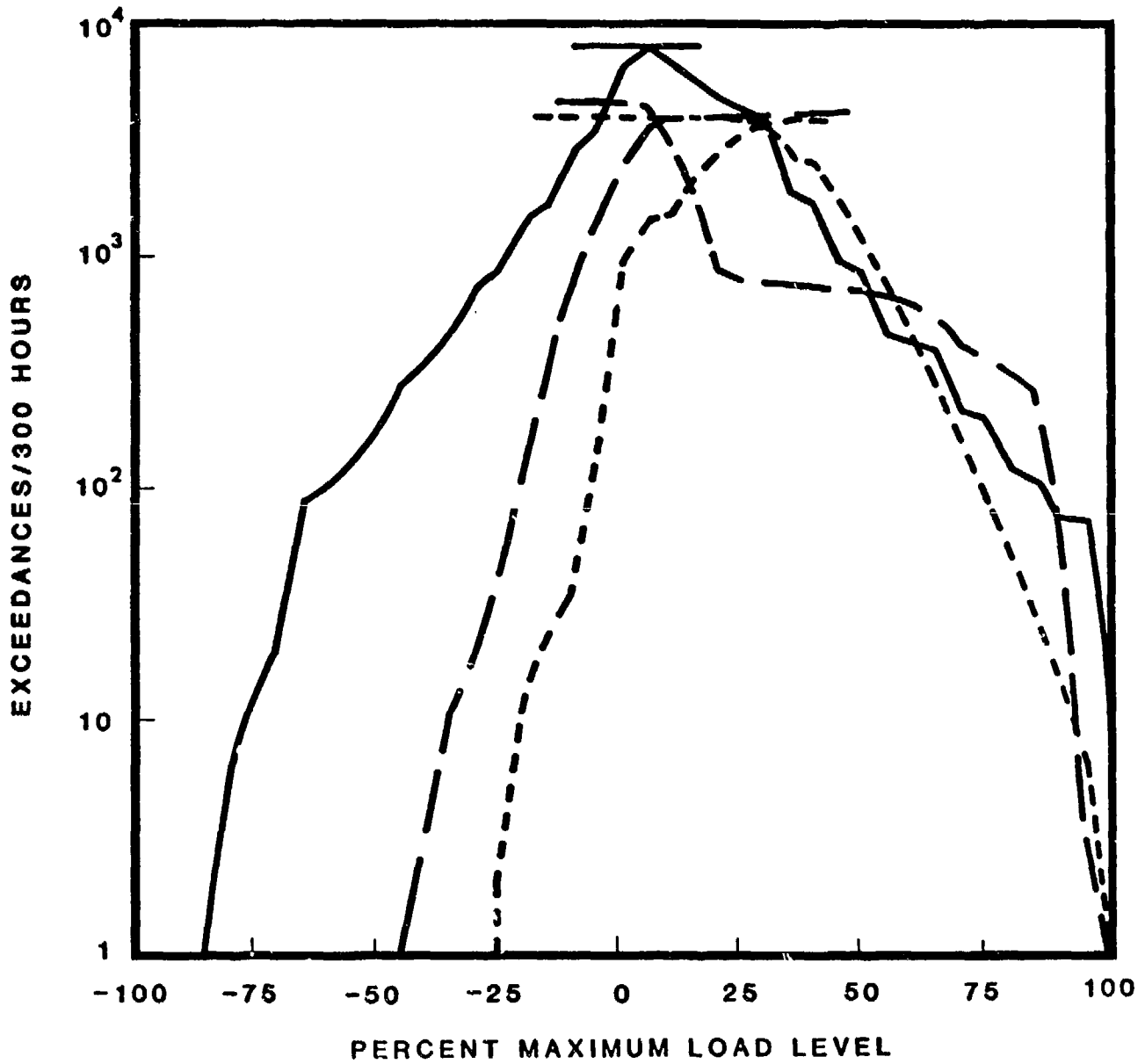

FIGURE 45. COMPARISON OF F-18 FATIGUE SPECTRA.

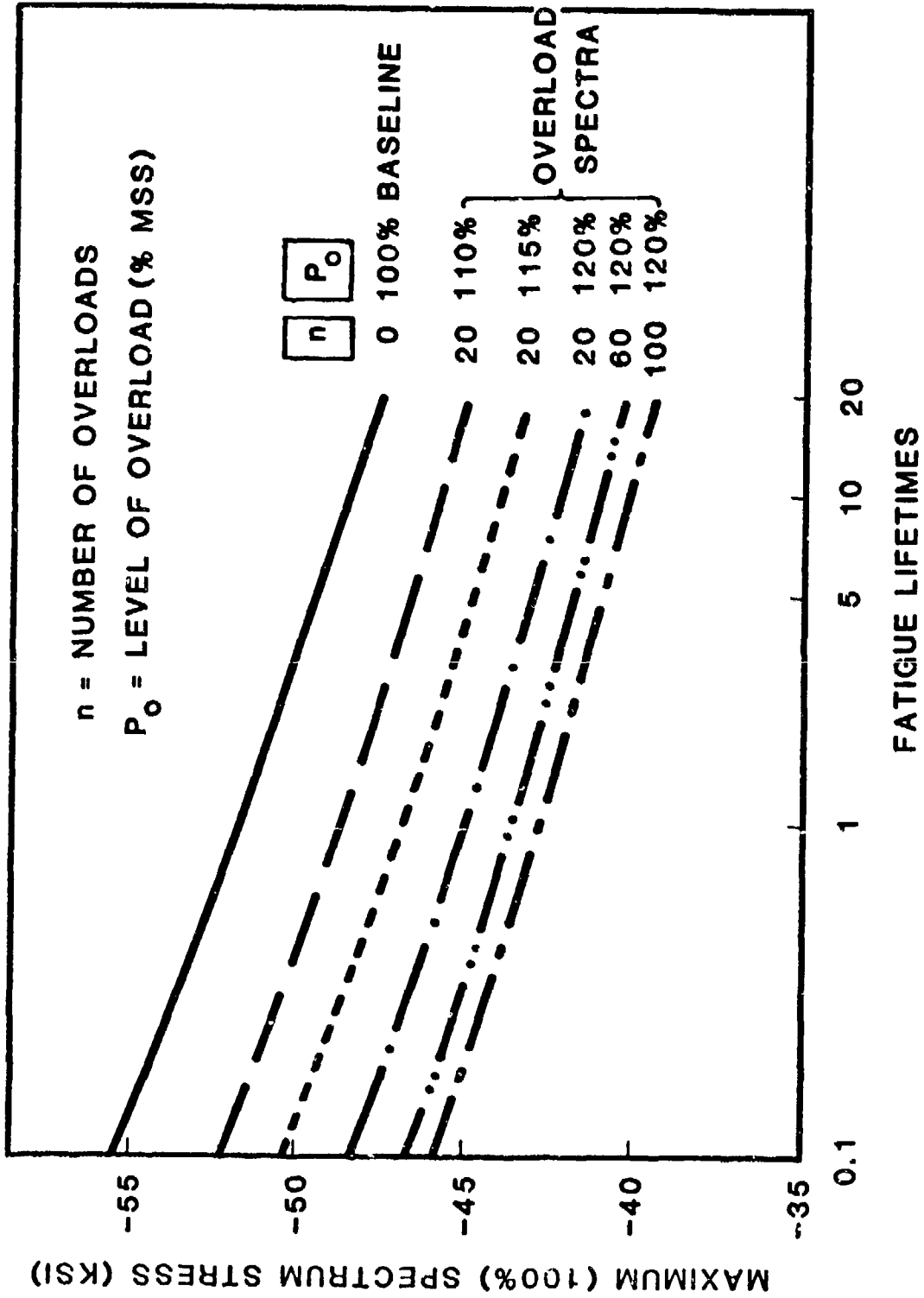

FIGURE 46. INFLUENCE OF OVERLOADS ON COMPOSITE FATIGUE LIFE FOR AN F-18 UPPER WING ROOT SPECTRUM.

aircraft lifetime. The data in Figure 46 show that overloads significantly reduce fatigue life for a constant maximum spectrum stress level (100 percent) for the allowable maximum spectrum stress level for a constant fatigue lifetime. This effect is observed for all three F-18 spectra type and is summarized in Figure 47. It can be seen that the influence of overloads on composite fatigue life is similar for all three spectrum types.

The overloads shown in Figure 47 are also checked for their influence on metallic fatigue life. For all overload/occurrence combinations, metal fatigue life remains within approximately ± 20 percent of the no overload baseline spectrum life. Thus, it is demonstrated analytically that overloads can be used to significantly reduce composite fatigue life, without significantly changing metal fatigue life. Figure 48 summarizes how overloads change the B-basis stress-life relationships for composites and metals. B-basis stress-life relationships are determined from mean values using the appropriate scatter factors for each material. These are determined from the Task I data analysis (see Volume I). For the metal data in Figure 48, the B-basis overload stress-life relationships is approximately equal to the B-basis baseline stress-life relationship. The B-basis overload stress-life relationship for composites includes the effects of both overload life sensitivity and increased fatigue life scatter (compared to aluminum). The data in Figure 48 show that the overloads significantly reduce the differences in life between metals and composites. However, the composite stress-life relationship remains very flat relative to the metal fatigue behavior. Thus, a common B-basis life for both materials is only established at one stress level (approximately 35 Ksi). At one fatigue lifetime, the allowable composite fatigue stress level is still significantly higher than that for aluminum.

It is, therefore, concluded that overloads can only cause an intersection (not overlap) of composite and metal B-basis stress-life relationships. This occurs because overloads

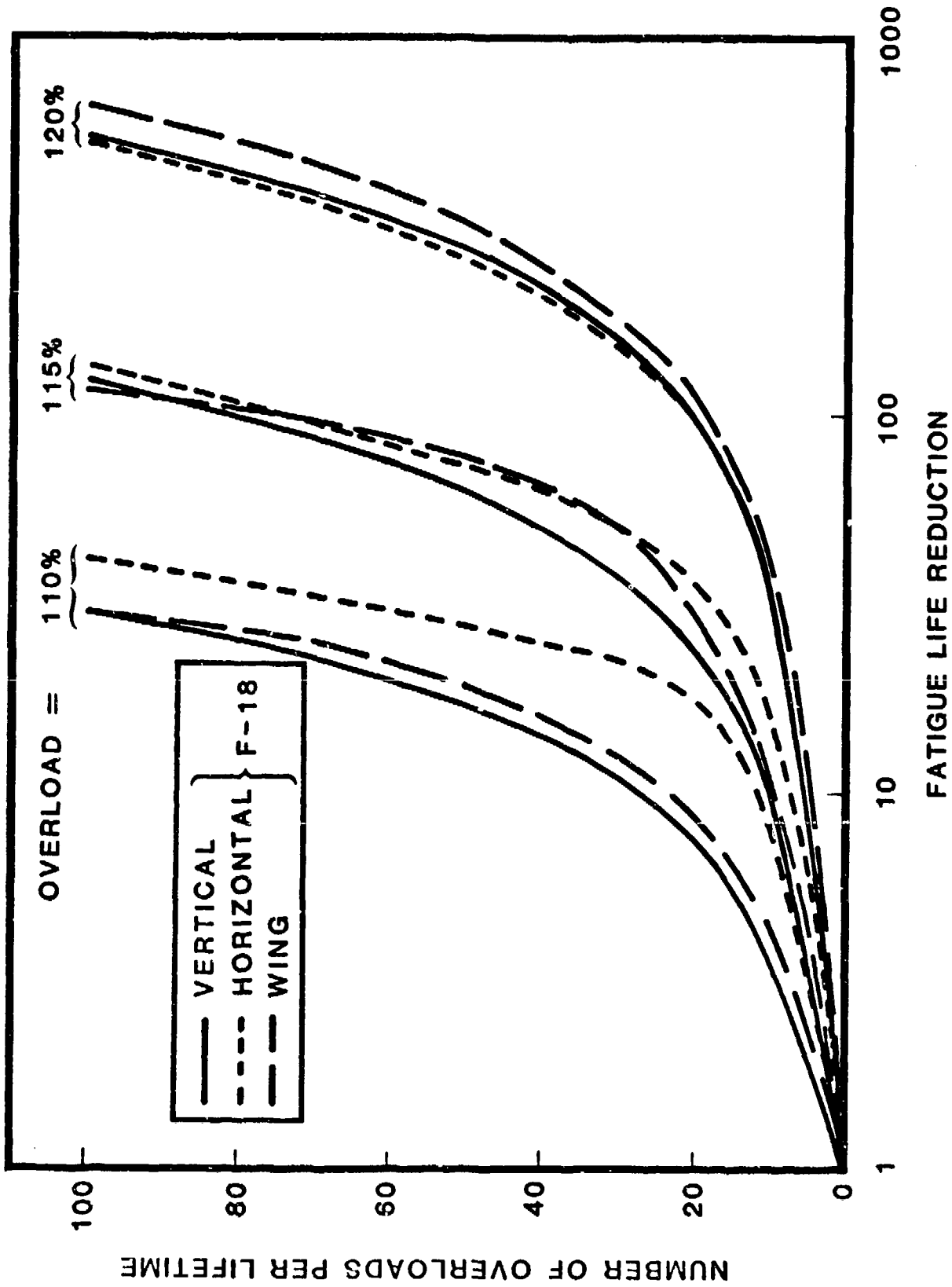

FIGURE 47. INFLUENCE OF SPECTRUM TYPE AND OVERLOADS ON COMPOSITE FATIGUE LIFE.

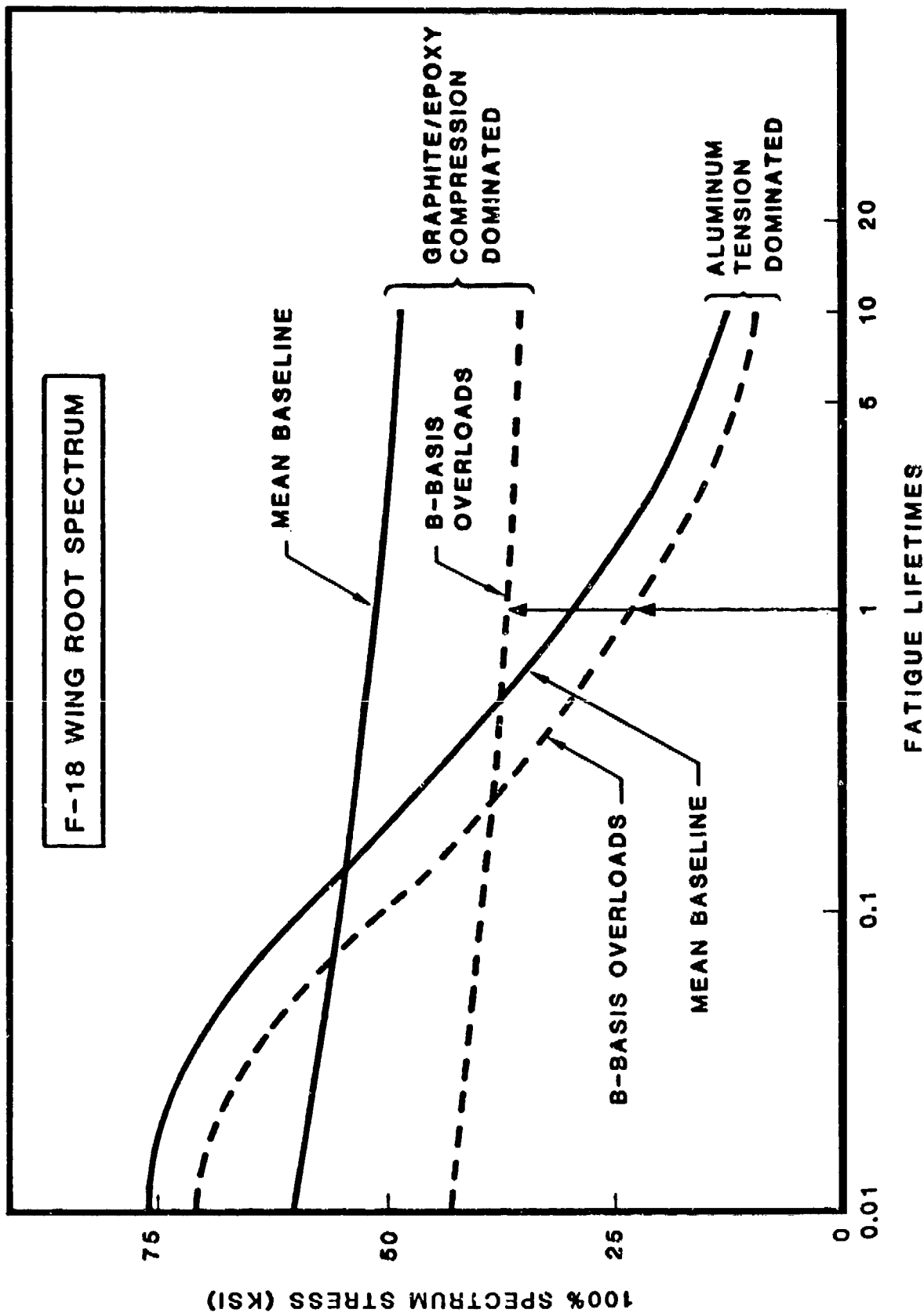

FIGURE 48. INFLUENCE OF OVERLOADS ON COMPOSITE AND METAL FATIGUE LIFE.

only reduce composite fatigue life. They do not alter the fatigue damage accumulation mechanisms, and thus cannot increase the slope of the S-N curve.

This observation does not necessarily limit the application of the overload approach to mixed structure fatigue testing. The influences of overloads on composite fatigue life (shown in Figure 46) can be used to calculate equivalent B-basis load enhancement factors. For example, Figure 25 shows that the B-basis LEF for a two lifetime fatigue test with $n = 1$ is 1.128. This value can be used to determine the number and magnitude of overloads which give a 1.128 times reduction in the allowable 100 percent stress level at two lifetimes. Thus, the overloads can be used to determine an equivalent test to the full load enhancement approach (all loads) for composites, without changing metal fatigue life. Thus, the disadvantage of the full LEF approach (Section 2.2) for mixed structure is overcome. Figure 49 summarizes the number and level of spectrum overloads required to demonstrate equivalent test severity to the full load enhancement approach. For the example discussed above, B-basis composite reliability for a two lifetime test can be achieved by using approximately ten 120 percent overloads/lifetime or approximately thirty-five 115 percent overloads/lifetime.

Thus, the change in spectrum approach can be used to provide demonstration of B-basis reliability for both composite and metals in a mixed structure without causing over severe metallic test. This significantly reduces the problems of mixed structure fatigue testing. It should be noted that the number and extent of overloads required will be spectrum type and stress-level dependent. In addition, transport or bomber type spectrum may be less amenable to this approach because of their relatively low number of high loads/lifetime. The promise of this approach should be explored in more detail and verified experimentally.

2.5 Summary of Certification Approach Evaluation

The evaluation of the Navy certification approach has

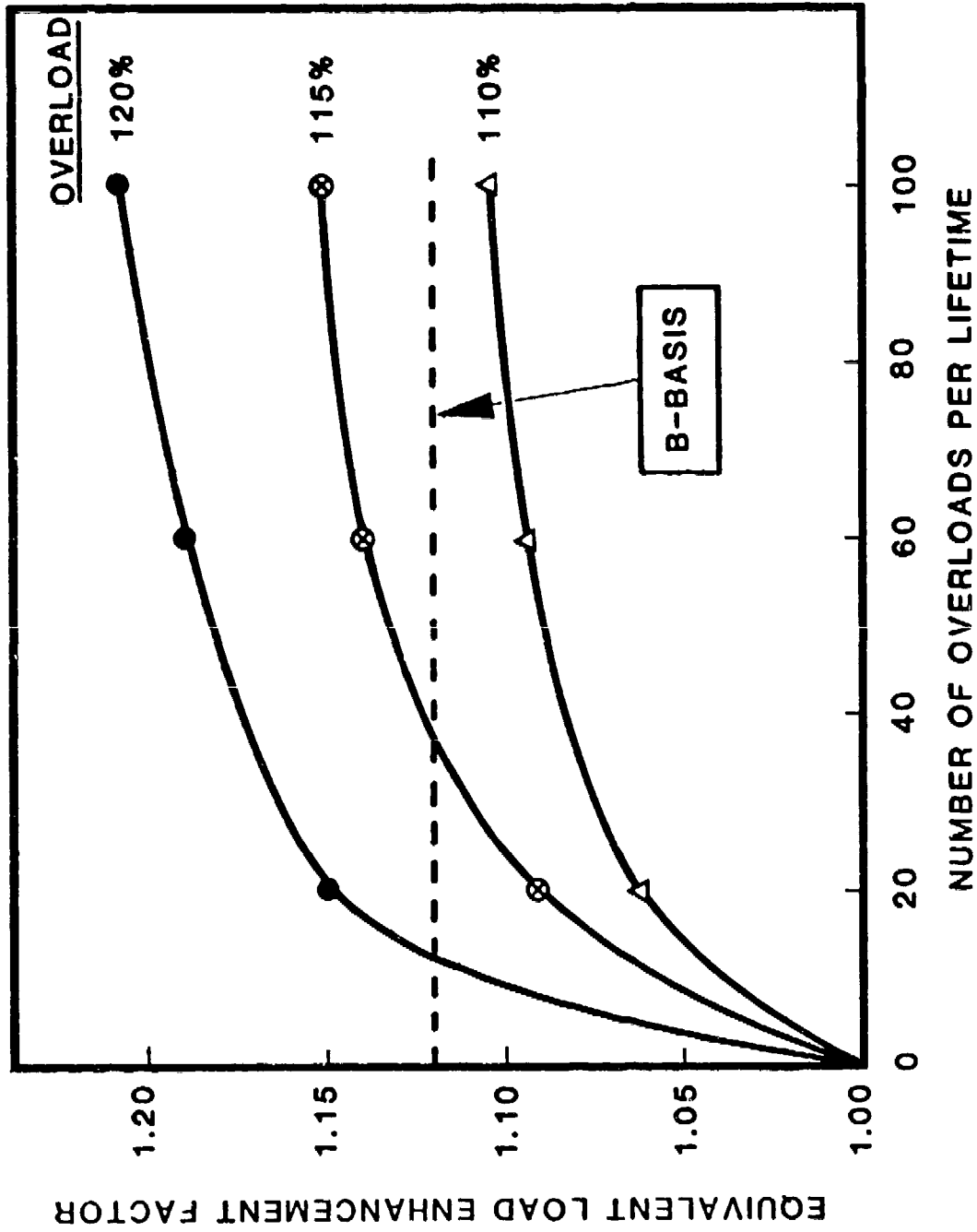

FIGURE 49. EQUIVALENT COMPOSITE LOAD ENHANCEMENT FACTORS FOR AN F-18 UPPER WING SPECTRUM.

shown that, in general, it is soundly based. In particular, it strikes a good balance between the technical requirements of the tests and cost effectiveness. For static testing, the main area of concern is the assumed ability to predict full-scale structure failure modes. Published data on full-scale composite static tests have shown that failure mode predictions are frequently incorrect. For fatigue testing, the two-lifetime fatigue test led to a concern about demonstrated fatigue reliability due to the high fatigue life scatter observed in composites. This is offset somewhat by the severe design spectra used. However, the degree of severity of the design spectra relative to the actual service spectra is uncertain at the time of certification.

Evaluation of the ultimate strength approach has established criteria for omission of a composite fatigue test. The overload requirement is shown to be a function of the fatigue spectrum type, specimen configuration, lay-up and test environment. In general, the ultimate strength approach has significant potential for reducing design development fatigue test requirements for composites.

The evaluation of the enhanced loads approach has shown that it has a sound theoretical basis and can be used with confidence for certification testing. However, some practical limits of this approach may exist. First, for asymmetric spectra, the degree of load enhancement may be limited because of a requirement not to exceed ultimate load. Second, for mixed structure, the enhanced load approach will provide an excessively severe fatigue test for the metal parts.

It is shown that the change in spectrum approach could not be used to overlap composite and metal B-basis stress-life relationships. This cannot be achieved because of the significant differences in the slopes of their stress-life relationships. However, it is shown that overloads can be introduced which permit demonstration of B-basis test reliability for both composite and metal parts in a mixed structure. This is achieved without making the test overly severe for metallic structures.

SECTION 3METHODOLOGY DEVELOPMENT

The high cost of full-scale structural test prohibits generation of a sufficient number of data for statistical analysis. Thus, for a meaningful interpretation of full scale structural tests, a building-block approach is developed for certification testing of composite structures. This approach fully utilizes coupon, element, subcomponent and component level test data so that a limited number of full-scale structural test data can be interpreted statistically. The number of tests decreases from the coupon level to the component level. A relatively large number of tests is required at the coupon level to establish the data scatter and B-basis statistics for different loading modes, failure modes and environments for both static and fatigue tests. A smaller number of tests is required at the element and subcomponent level to determine the failure mode interaction and a sufficient number of component tests to demonstrate the variability in structure response. This information is then used for interpretation of the full-scale structural test data. The number and types of test specimens required for the building block approach are specified in Section 5. The variability in structural response is discussed in the following paragraphs.

3.1 Concept of Structural Response Variability (SRV)

In structural tests, aside from the scatter in the basic material properties, other factors will contribute to the scatter in structural response. The contributing factors (above the coupon level) are structural geometry, design tolerances, manufacturing and material nonuniformity and loading conditions. Because of this scatter in structural response, unexpected "hot-spot" failure can occur during static structural tests. Figure 50 shows schematically a potential static "hot-spot" failure in relation to the scatter in material strength and structural response. The shaded area where the two distributions intersect

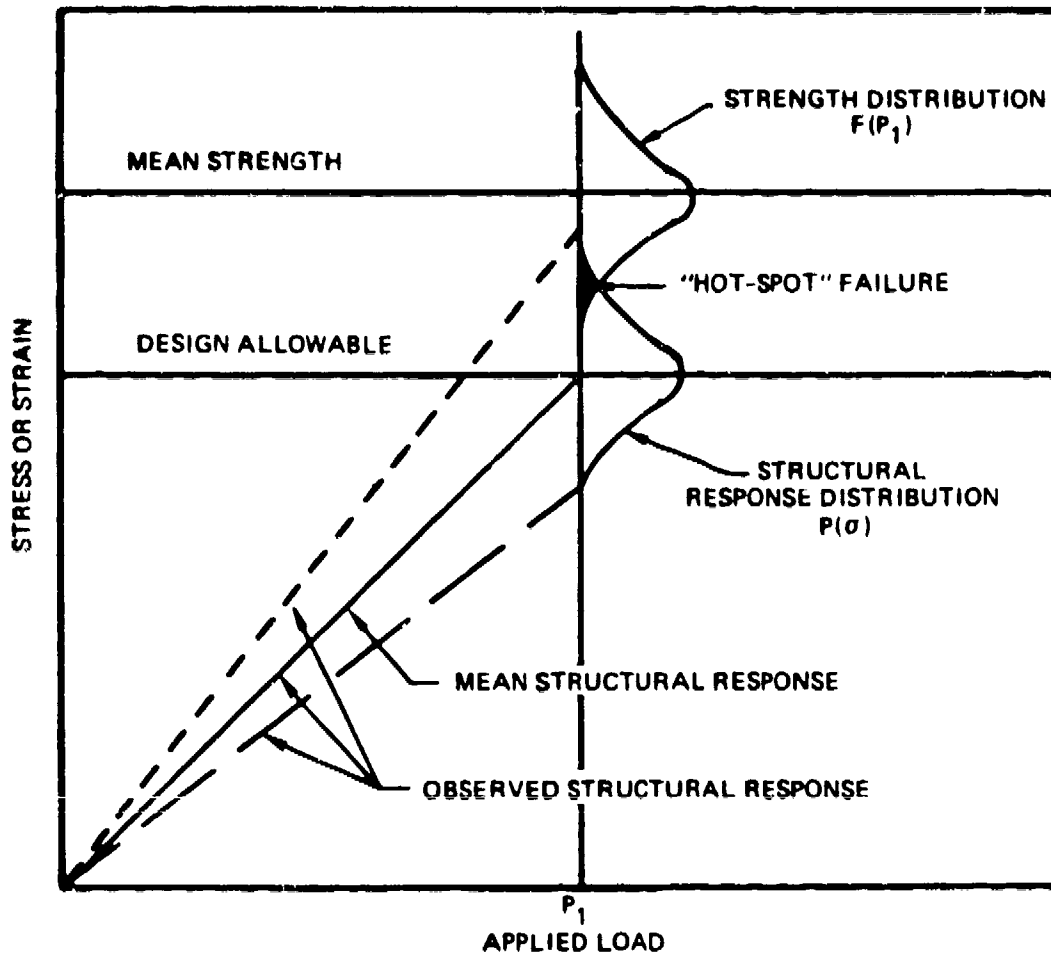

FIGURE 50. SCHEMATIC OF "HOT-SPOT" FAILURE IN RELATION TO THE SCATTER IN STRENGTH AND IN STRUCTURAL RESPONSE FOR A STATIC TEST.

represents the probability of failure at a certain location of the structure under the applied load P_1 . In order to interpret the data statistically, both the material strength and structural response distributions must be obtained for different locations on the structure. This cannot be achieved from a limited number of full-scale structural tests.

The building block approach requires utilization of coupon level tension and compression static test data to establish the basic material strength distribution and element combination and subcomponent level test data to establish the structural response distribution. The structural reliability or the probability of structural failure (hot-spot failure) is then calculated from these two distributions as follows:

Using a joint probability function to combine the influence of material static strength scatter and the SRV, the probability of survival of a structure under a static load level of P_1 is given by

$$S(P_1) = \int_0^{\infty} F(P_1) \cdot p(\sigma) d\sigma \quad (26)$$

where: $F(P_1)$ is the survivability of the structure at load level P_1 considering strength scatter only

$p(\sigma)$ is the probability of occurrence that the actual stress level in the structure is σ due to SRV.

The survivability function $F(P_1)$ describes the static strength due to material scatter only. Therefore, the Weibull parameters obtained from the static strength data analysis in Task I can be used in Equation (26).

The scatter in structural response is a result of several factors, as discussed earlier. The proportion that each of these factors contribute to the total scatter in structural response is difficult to determine. The use of strain gages to measure structural response gives the combined effects of these

factors. To utilize the strain data in evaluating the scatter in structural response, a combined distribution, such as $p(\sigma)$ in Equation 26 is necessary.

The form of the distribution function $p(\sigma)$ can be assumed as a normal distribution or a two-parameter Weibull distribution. Within the range of observed SRV's for static testing, the two distribution yield approximately the same results when used in Equation (26). Numerical integration of Equation (26) has been carried out to evaluate the influence of SRV on the structural reliability. The results of these calculations are shown in Figure 51 through 54.

The influence of SRV on the design allowables depends on the static strength variability, which is characterized by the the static strength distribution Weibull shape parameter (α_S), and the sample size. It can be seen from Figures 51 and 52 that additional reduction factors (from the baseline values) on the design allowables are required to accommodate the structural response variability. However, within the range of the SRV values determined in Section 3.2, the additional reduction factor is fairly small. The numerical values of the reduction factors for mean and modal SRV with a single article test are given in Table 4. The B- and A-basis knockdown factors at mean and modal SRV values for various values of α_S are shown in Figures 53 and 54. In comparing these results with the baseline knockdown factors (no SRV), it is seen that the design allowables are dominated by the static strength variability, and that SRV is a secondary consideration.

The influence of structural response variability and the 95 percent reliability (R) for the baseline B- and A-basis design allowables is shown in Figures 55 and 56. The structural reliability decreases as the SRV increases (decreasing α_{SRV}). The influence of SRV on reliability does not depend on the sample size but depends on the static strength variability α_S . At high levels of static strength variability (low α_S), the influence of SRV on reliability, R, is small. However, at low levels of

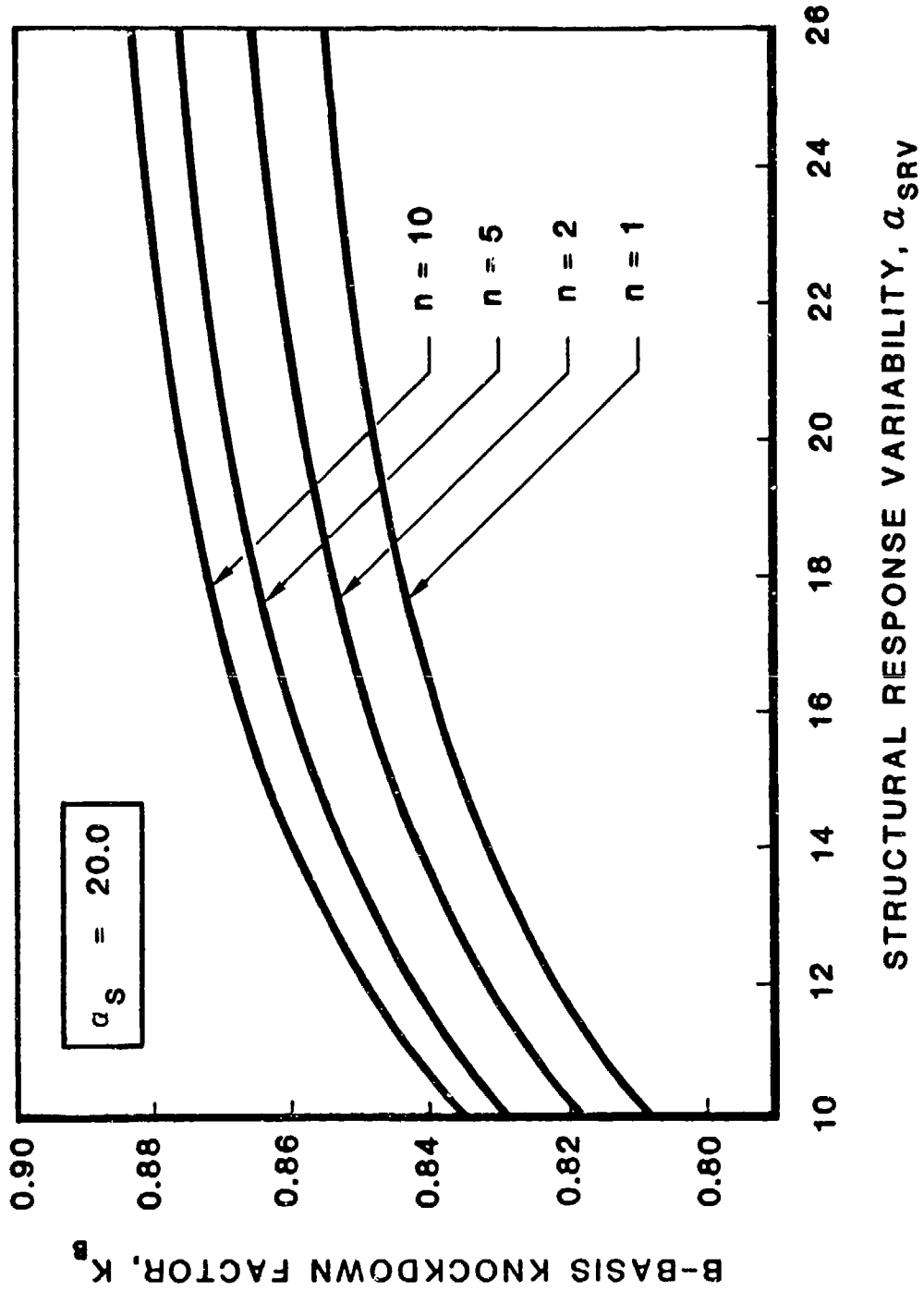

FIGURE 51. INFLUENCE OF SRV ON B-BASIS DESIGN ALLOWABLES, $\alpha_S = 20.0$.

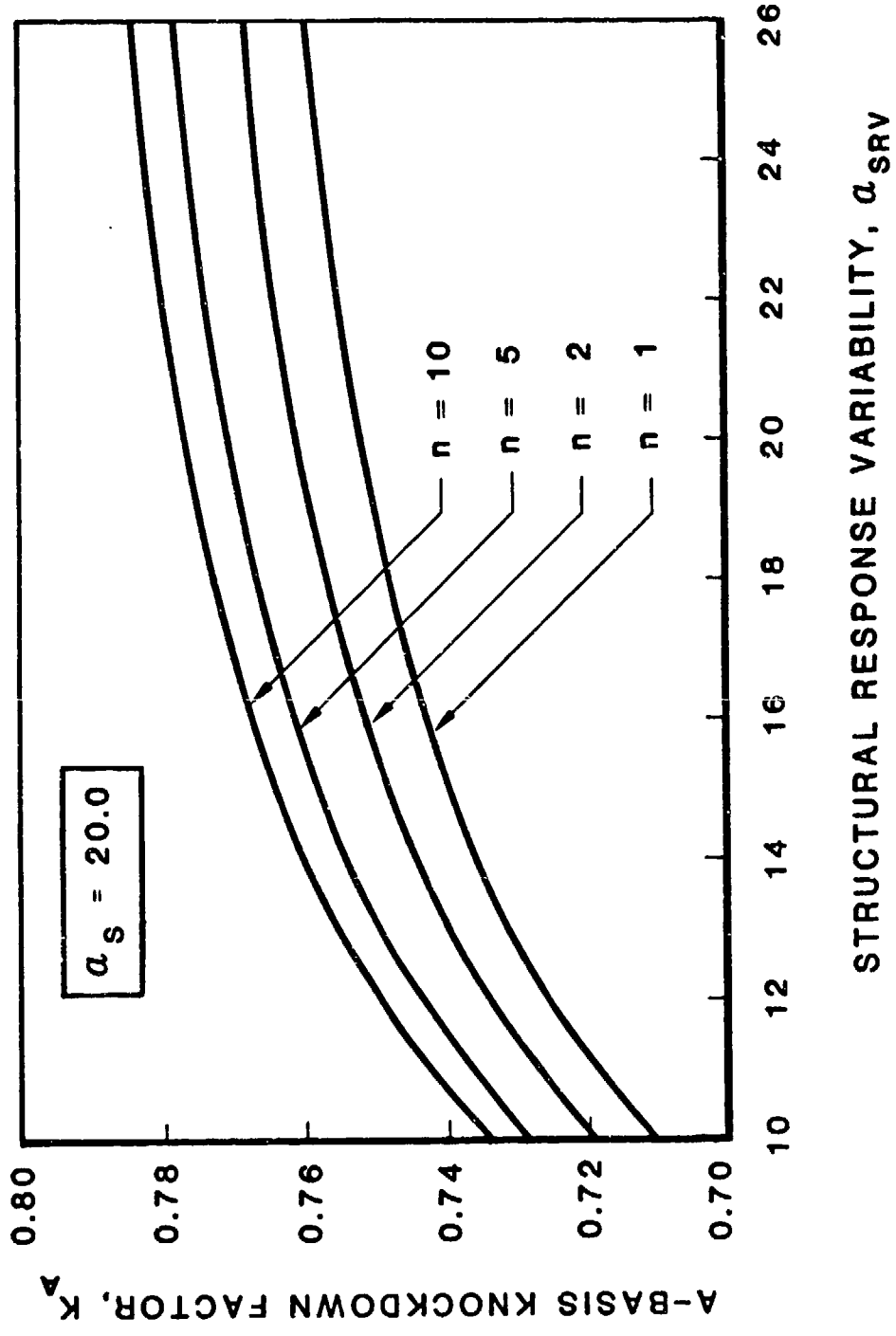

FIGURE 52. INFLUENCE OF SRV ON A-BASIS DESIGN ALLOWABLES, $\alpha_S = 20.0$.

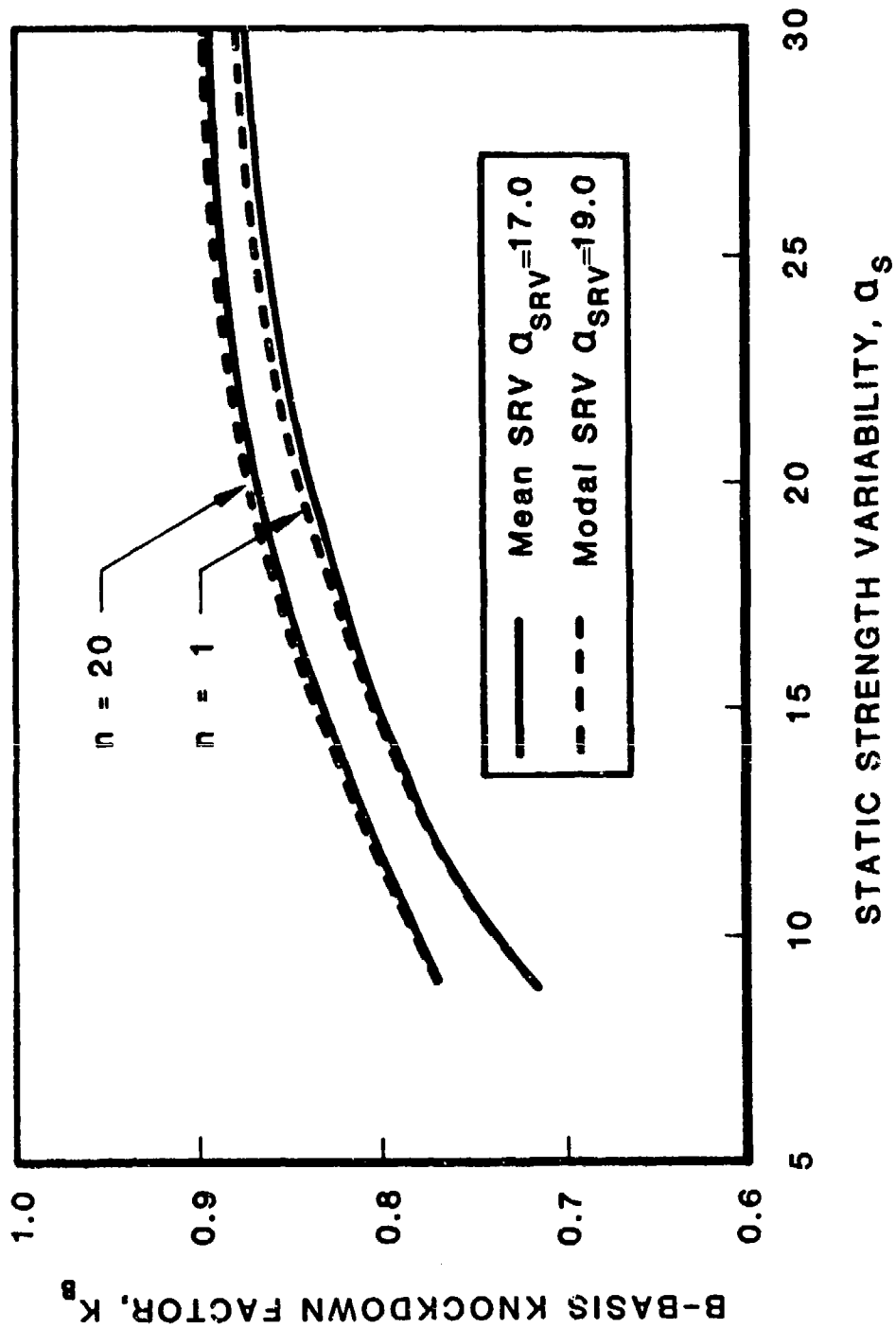

FIGURE 53. INFLUENCE OF STATIC STRENGTH VARIABILITY ON THE B-BASIS DESIGN ALLOWABLE AT MEAN AND MODAL SRV.

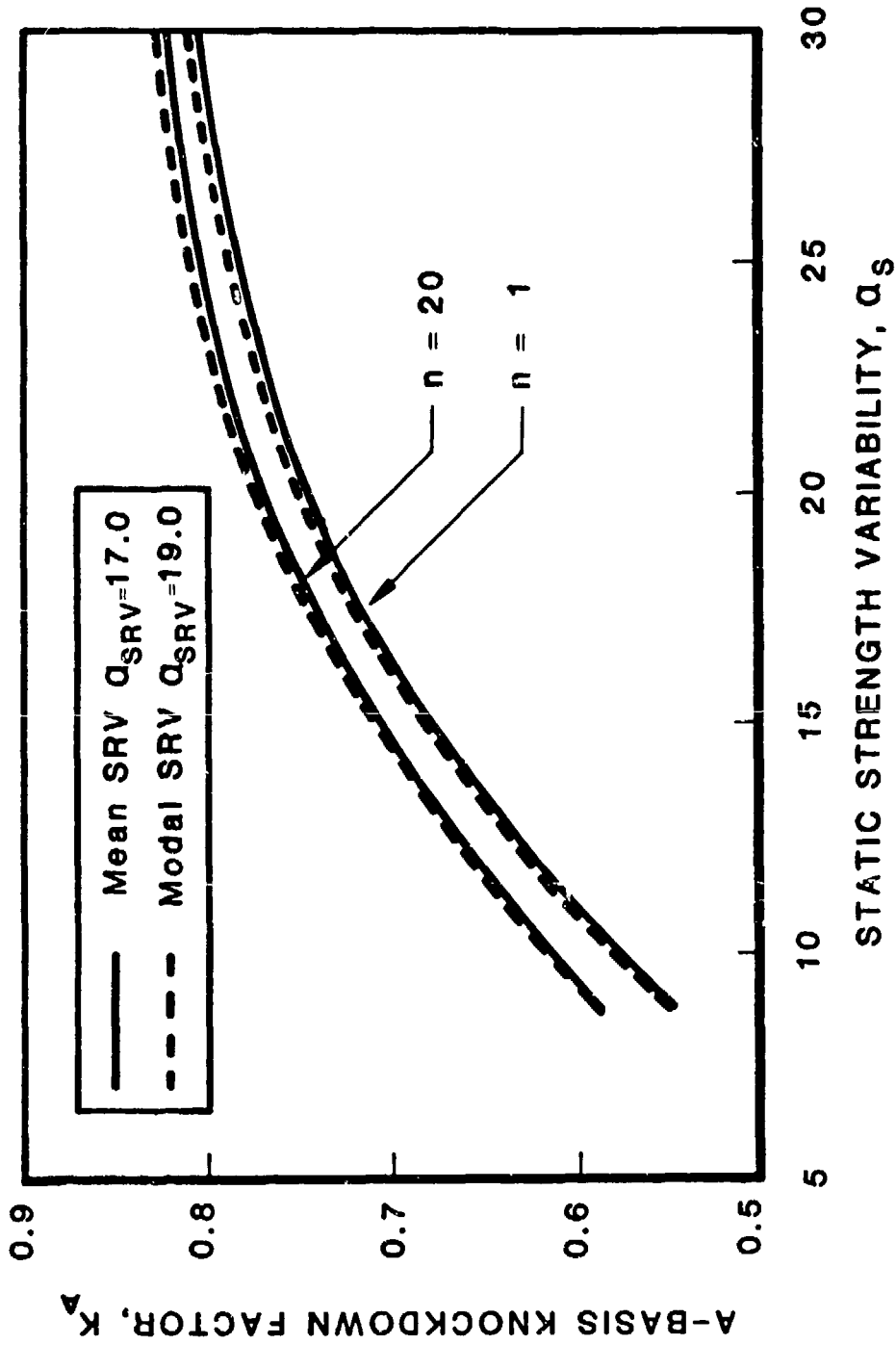

FIGURE 54. INFLUENCE OF STATIC STRENGTH VARIABILITY ON THE A-BASIS DESIGN ALLOWABLE AT MEAN AND MODAL SRV.

TABLE 4. INFLUENCE OF SRV ON KNOCKDOWN FACTORS, $n = 1$.

	NO SRV	MEAN SRV	MODAL SRV
a_s	∞	17.0	19.0
CV	0	0.071	0.065
a_m	B-BASIS KNOCKDOWN FACTOR		
8.8 (B-BASIS)	0.723	0.711	0.713
20.0 (MODAL)	0.869	0.842	0.846
23.2 (MEAN)	0.886	0.855	0.860
30.0 (UPPER)	0.911	0.874	0.879
	A-BASIS KNOCKDOWN FACTOR		
8.8 (B-BASIS)	0.553	0.544	0.545
20.0 (MODAL)	0.773	0.746	0.750
23.2 (MEAN)	0.801	0.775	0.770
30.0 (UPPER)	0.842	0.803	0.810

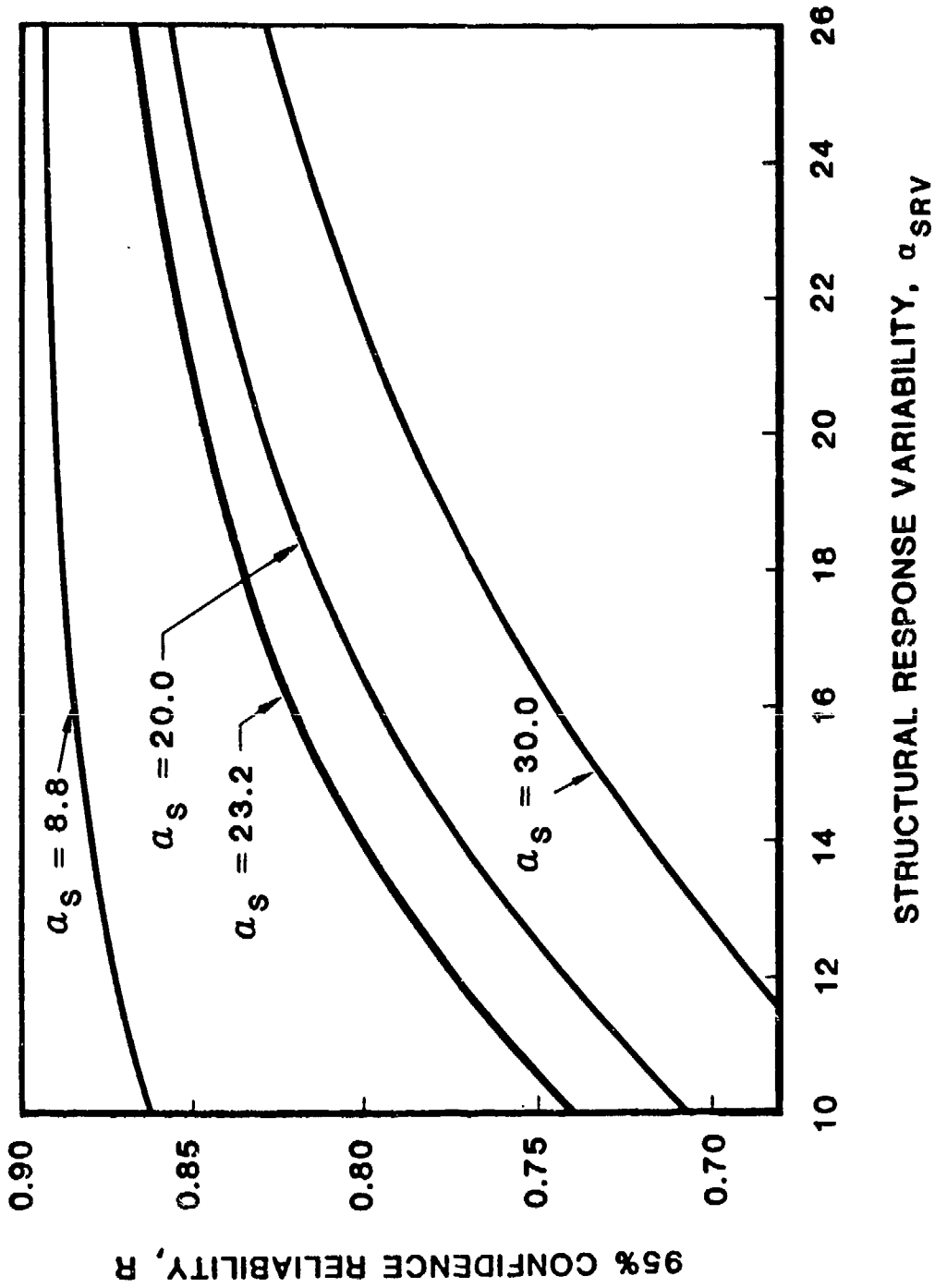

FIGURE 55. INFLUENCE OF STRUCTURAL RESPONSE VARIABILITY ON THE B-BASIS STRUCTURAL RELIABILITY.

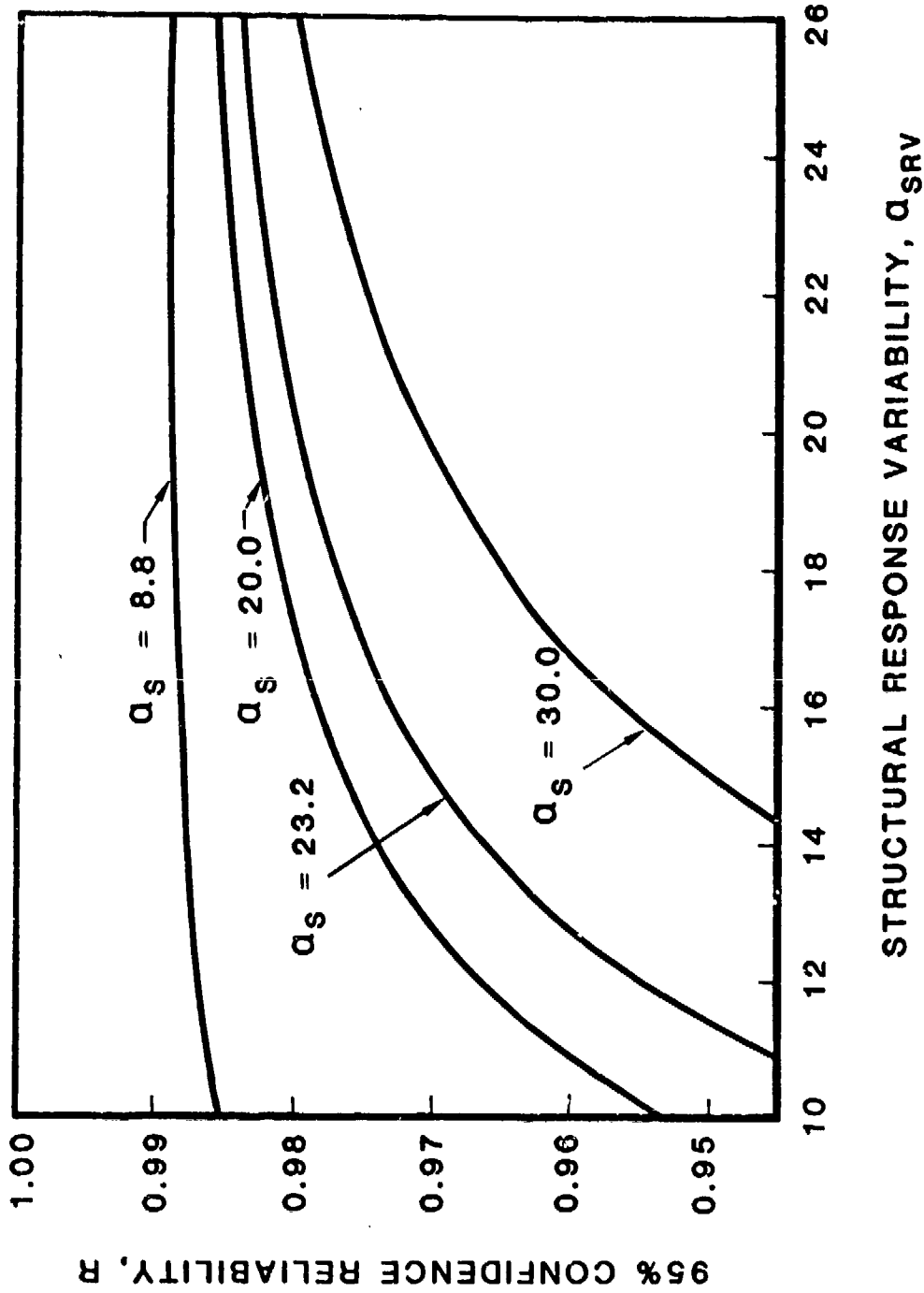

FIGURE 56. INFLUENCE OF STRUCTURAL RESPONSE VARIABILITY ON THE A-BASIS STRUCTURAL RELIABILITY.

static strength variability (high α_S), the reliability decreases significantly as SRV increases. This can be seen in Figure 55. For B-basis reliability (95 percent confidence, 90 percent probability), at $\alpha_S = 8.8$ the reliability reduces from 0.90 for $\alpha_{SRV} = \infty$ to 0.863 for $\alpha_{SRV} = 10.0$. Whereas for $\alpha_S = 30.0$, the reliability reduces to 0.655. Similar results can be observed for A-basis reliability shown in Figure 56.

3.2 Structural Response Variability Data

The extensive test data generated in Reference 5 have been used as a strain gage data source. The building block approach used in Reference 5 for the wing structure is shown in Figure 57. The design development test specimens are characterized by four levels of structural complexity. The fifth level of complexity is assigned to the full-scale wing component. Further details of the wing specimens are discussed in Section 4. Table 5 summarizes the load-strain data available from Reference 5.

3.2.1 Determination of Structural Response Variability

To determine the structural response variability from the strain data, three or more nominally identical specimen tests are required. A typical data set from Reference 5 is shown in Figure 58. Strain data at the critical locations obtained from the structural test are normalized with respect to the mean strain at each load level. The distribution of the normalized strain is then fitted to a normal or Weibull distribution to evaluate the scatter in structural response. It should be noted that only the scatter of the structural response is of interest in this evaluation. The actual magnitude of the strain is not important. The structural response variability is characterized by the coefficient of variation in a normal distribution and by the shape parameter in the Weibull distribution. The combined structural response variability can then be obtained by integrating equation (26) with the given probability distributions.

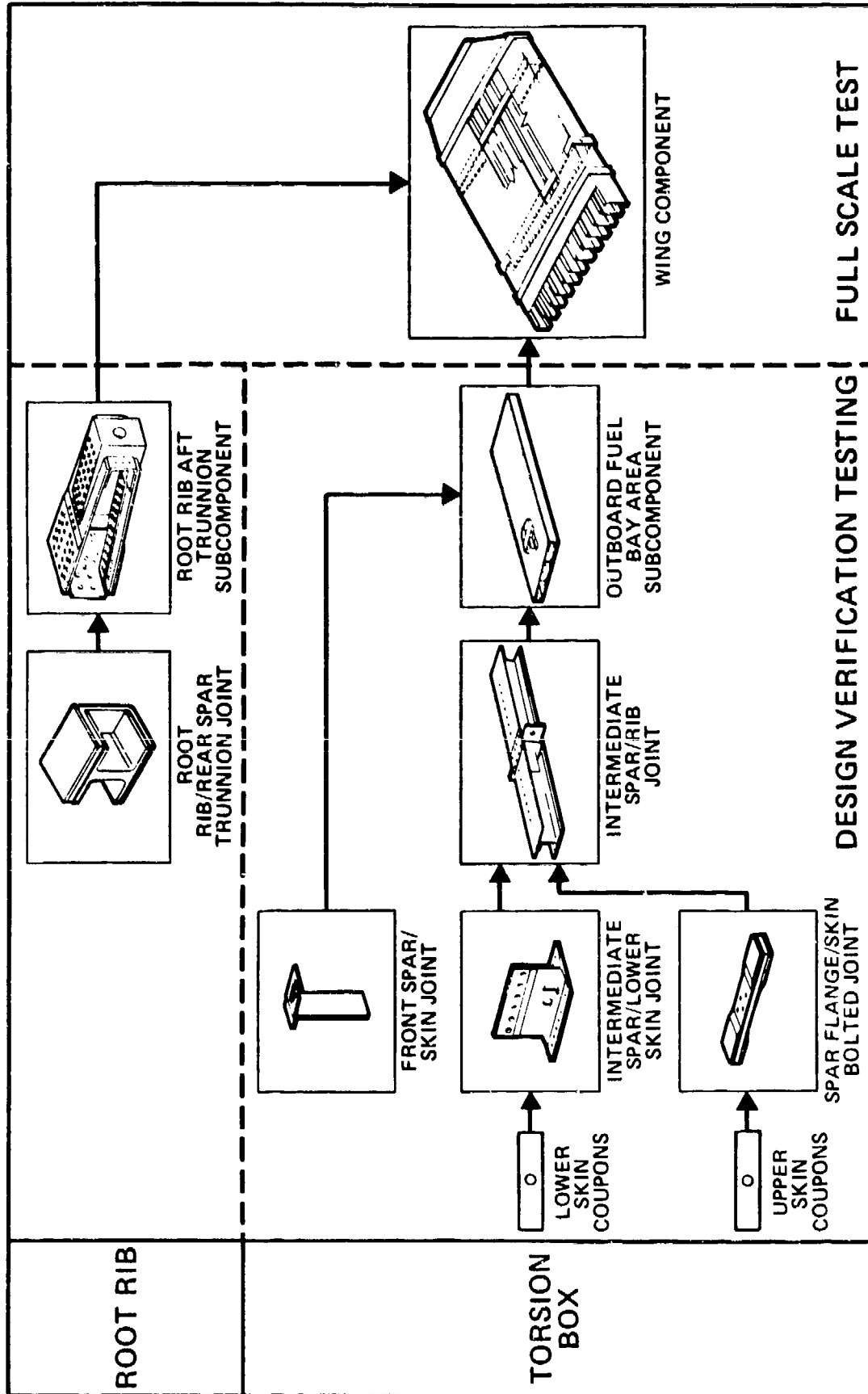

FIGURE 57. BUILDING BLOCK APPROACH FOR THE WING STRUCTURE IN THE COMPOSITE WING/FUSELAGE PROGRAM (REFERENCE 5).

TABLE 5. SUMMARY OF STRAIN GAGE DATA AVAILABLE FROM THE COMPOSITE WING/FUSELAGE PROGRAM (REFERENCE 5).

COMPLEXITY LEVEL	SPECIMEN	NUMBER OF SPECIMENS			
		STATIC		RESIDUAL STATIC STRENGTH	
		RT/AMBIENT	250°F/WET	RT/AMBIENT	250°F/WET
1	COMPRESSION COUPONS TENSION COUPONS	23 9	23 9	23 9	23 9
2	WE-2 WEC-1	3 3	3 3	3 6	3 6
3	WEC-3	3	3	6	6
4	WS-1 WS-2	2 1	3 2	--- 1	5 1
5	WCC-1	1	1	1	---

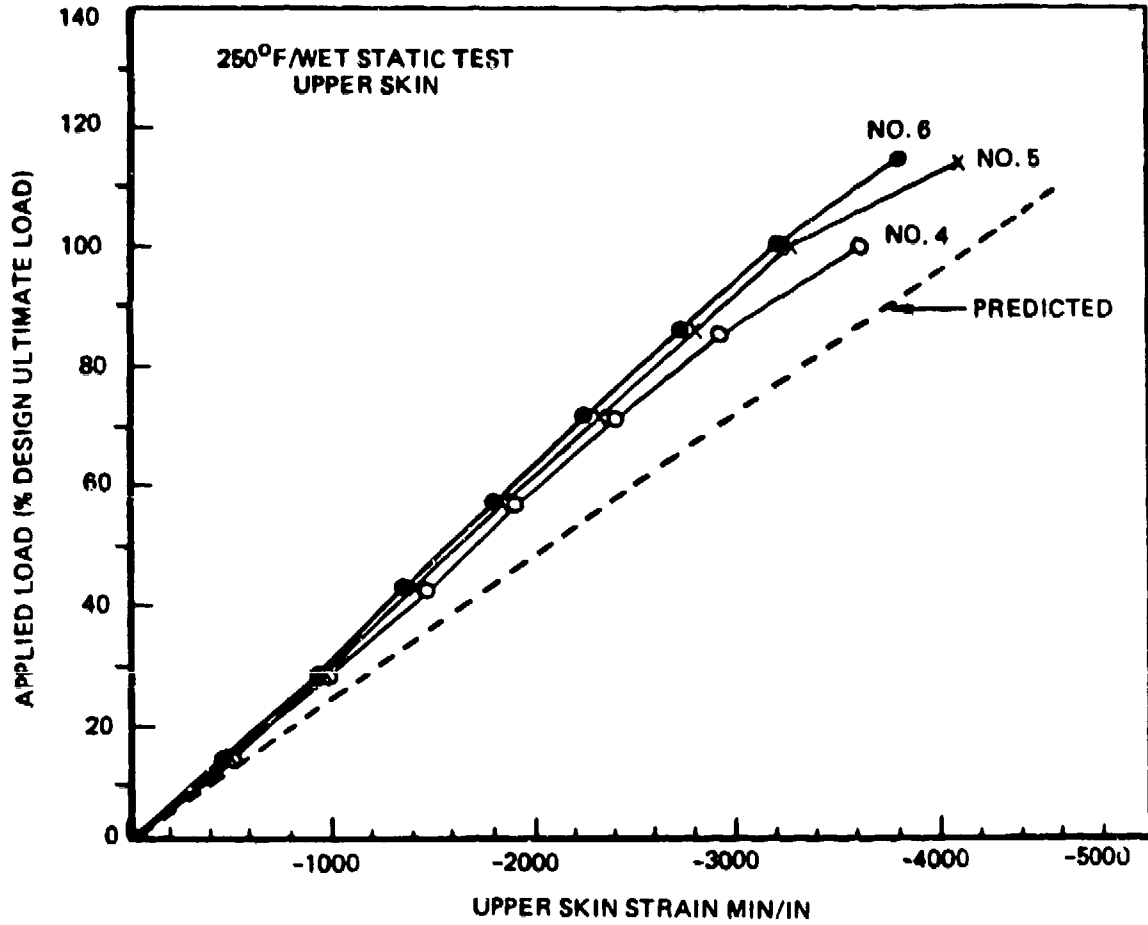

FIGURE 58. TYPICAL APPLIED LOAD STRAIN RESPONSE FROM A WS-1 SUBCOMPONENT TEST (REFERENCE 5).

3.2.2 Structural Response Variability Analysis Results

The results of the structural response variability analysis are presented in Table 6. The location of the strain gages on each specimen are given in the table.

For analysis purposes, the load-strain data are separated into three categories: RTA, ETW and the combined RTA and ETW data. In each category, static and residual static strength data are pooled. This significantly increased the amount of load-strain data available for analysis. Residual static strength load-strain data are included because these tests showed no fatigue degradation and exhibited no significant losses in static strength after two lifetimes of fatigue loading.

In general, the load-strain response of all specimens was essentially linear to failure. A typical example is presented in Figure 59, which shows the ETW lower skin load-strain response of the WS-1 box beam. Figures 60 through 64 show the upper skin load-strain response of the wing component close to the root rib. These data also show essentially linear load-strain response. The ETW upper skin load-strain response of the WS-1 box beam presented in Figure 60 shows nonlinear load-strain response and high structural response variability. The nonlinear load-strain response can be attributed to the severe test environment (250°F/1.3% moisture). This is the only load-strain data analyzed in Table 6, which exhibited significant nonlinear load-strain response. It should be noted that this type of load-strain response is not accounted for in the Navy scatter factor approach to certification.

The influence of specimen complexity on structural response variability is presented in Table 6 and summarized in Figures 65 through 67. The data show that structural response variability does not increase as specimen complexity increases. This observation holds true for the RTA, ETW and combined RTA/ETW load-strain data sets. In fact, the structural response variability of the wing component (complexity level 5) is less than the overall average for the RTA and combined RTA/ETW data sets.

TABLE 6. STRUCTURAL RESPONSE VARIABILITY ANALYSIS RESULTS.

SPECIMEN I.D.	SPECIMEN DESCRIPTION	FAILURE MODES	SPECIMEN COMPLEXITY LEVEL	GAGE NO.	GAGE LOCATION	STRUCTURAL VARIABILITY IN LOAD-STRAIN RESPONSE					
						ETA		ETM		ETA + ETM	
						n	C.V.%	n	C.V.%	n	C.V.%
WC-1 WC-2 WC-3 WC-4 WC-5 WC-6	Upper Wing Skin Coupon	NET SECTION AT FASTENER HOLE	1	-	GAGE SECTION	20	3.4	19	4.5	39	5.1
	Lower Wing Skin Coupon		1	-		6	5.2	5	10.4	11	7.9
	Upper Wing Skin Coupon		1	-		20	3.4	15	3.4	35	3.5
	Lower Wing Skin Coupon		1	-		6	2.7	4	3.8	10	5.4
	Upper Wing Skin Coupon		1	-		4	3.1	5	7.1	9	5.5
	Upper Wing Skin Coupon		1	-		6	1.4	6	2.6	12	5.3
WE-2	Upper Wing Skin/Spar Bolted Joint Element	FASTENER HOLE	2	-	UPPER SKIN	6	1.9	-	-	6	1.9
WEC-1	Lower Wing Skin/Intermediate Spar Cocured Joint Element Combination	SPAR WEB FUEL DRAIN HOLE	2	14	SPAR WEB	6	7.0	4	13.7	10	9.5
	Wing Intermediate Spar/Rib Joint Element Combination	COURED JOINT UPPER SKIN	3	7A 8A 15(ϵ_f)	LOWER SKIN UPPER SKIN SPAR WEB	6 6 6	7.6 9.7 13.8	4 4 5	5.3 4.9 8.5	10 10 11	7.0 8.6 12.2
WS-1	Wing Outboard Fuel Bay Subcomponent	UPPER SKIN LOWER SKIN COURED JOINT	4	19 21R1 21R2 23 20 22R1 22R2 24 11	UPPER SKIN	3	13.1	6	5.7	9	9.0
						2	10.8	6	17.5	8	15.9
						2	8.9	5	14.9	7	13.4
						2	4.9	6	7.7	8	7.1
						2	2.7	4	4.9	6	4.2
						2	11.6	7	7.0	9	6.3
WS-2	Wing Root Rib Aft Trunnion Subcomponent	RIB WEB	4	24 11	RIB WEB	3	1.3	5	7.8	7	6.6
						3	9.6	4	2.4	7	6.6
						-	-	2	6.3	3	8.1
						2	3.6	-	-	3	9.7
WCC-1	Wing Component	COURED JOINT UPPER SKIN	5	25 30 32 40 52 65 68 86 92 98	UPPER SKIN	2	7.1	-	-	3	8.0
						2	5.9	-	-	3	5.6
						2	3.1	-	-	3	6.7
						2	6.0	-	-	3	7.0
						2	1.3	-	-	3	2.9
						2	1.2	-	-	3	6.5
						2	9.0	-	-	3	7.4
						2	7.0	-	-	3	4.7
						2	2.4	-	-	3	5.4
						2	3.6	-	-	3	9.7

Notes: n = number of load-strain plots analyzed
 ϵ_Q = spar web shear strain

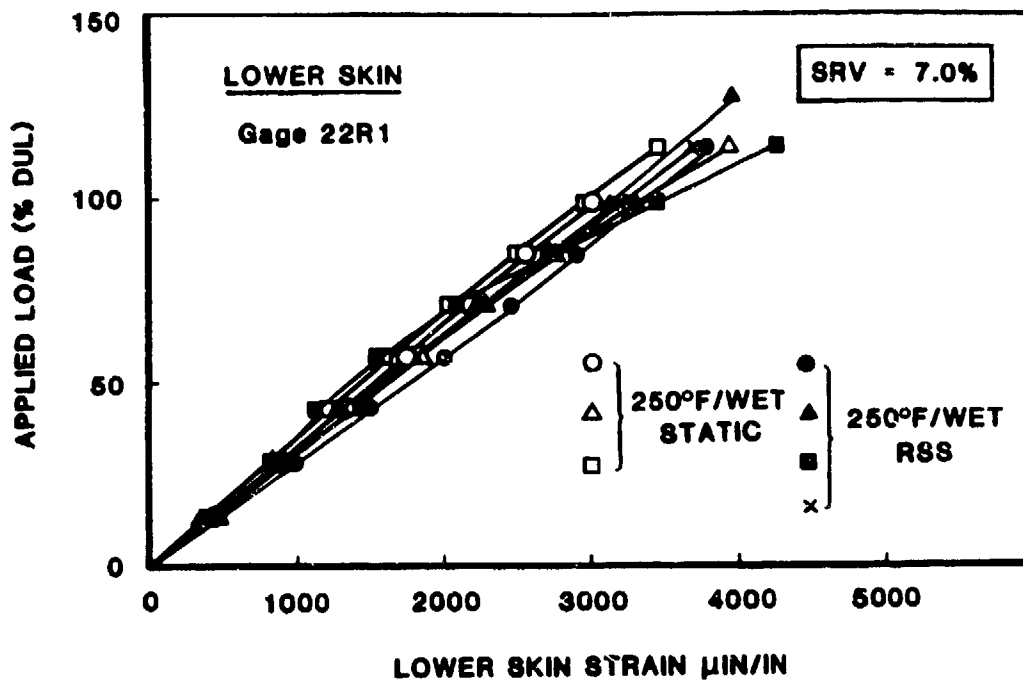

FIGURE 59. WS-1 LOWER SKIN ETW LOAD-STRAIN RESPONSE.

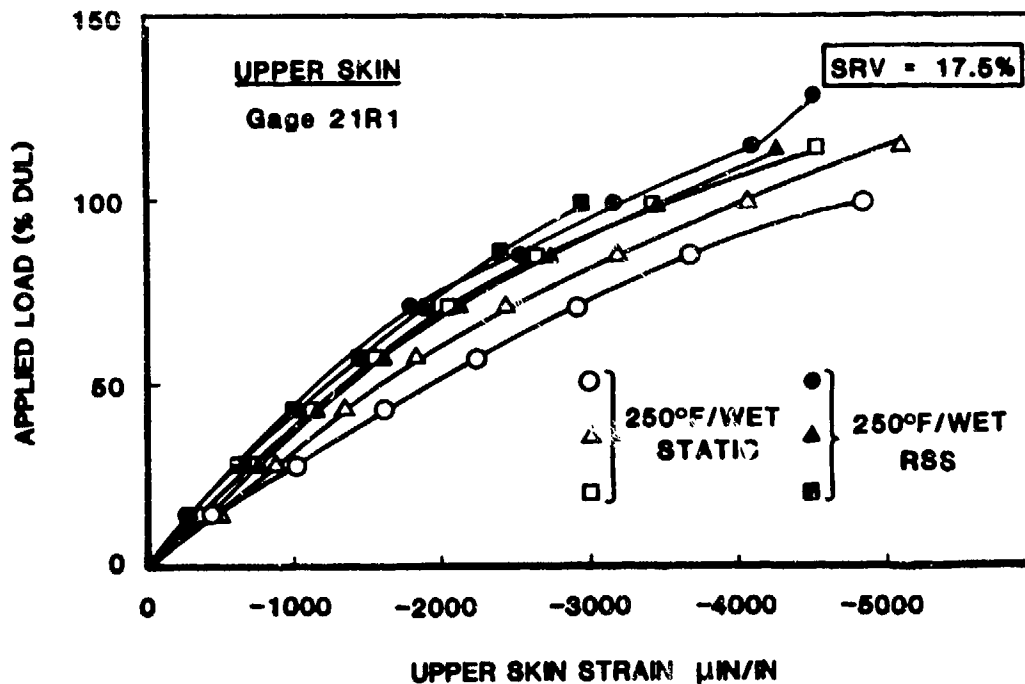

FIGURE 60. WS-1 UPPER SKIN ETW LOAD-STRAIN RESPONSE.

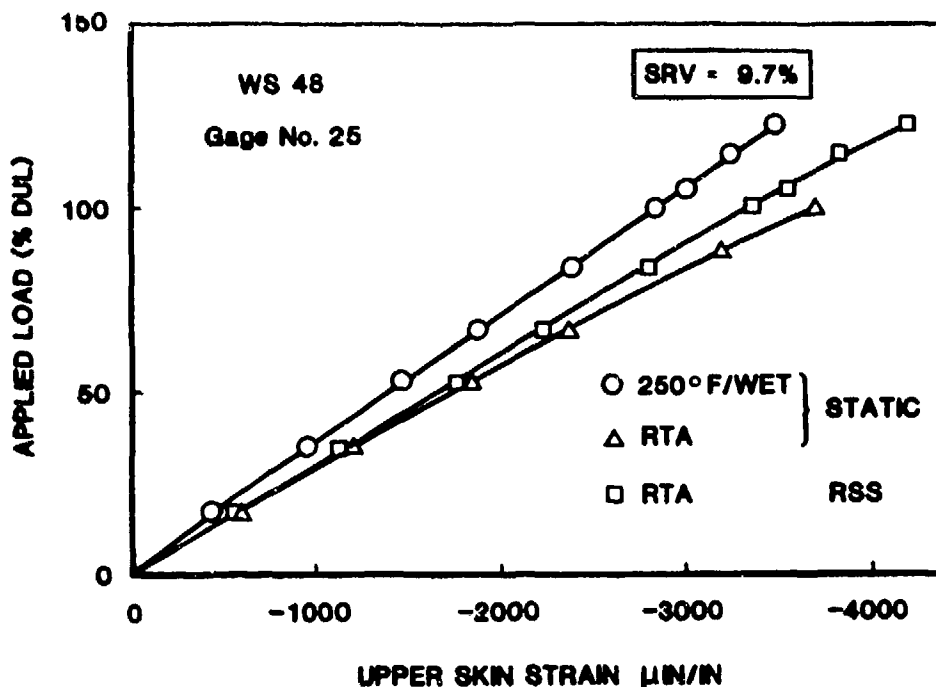

FIGURE 61. WCC-1 UPPER SKIN LOAD-STRAIN RESPONSE AT WING STATION 48 (GAGE NUMBER 25) FOR LOAD CASE 130.

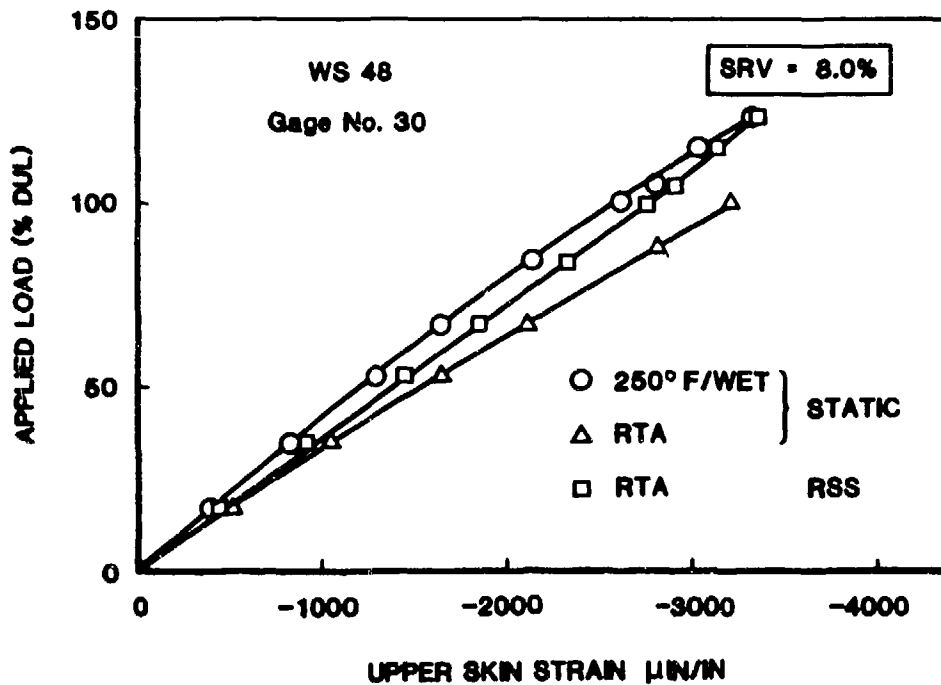

FIGURE 62. WCC-1 UPPER SKIN LOAD-STRAIN RESPONSE AT WING STATION 48 (GAGE NUMBER 30) FOR LOAD CASE 130.

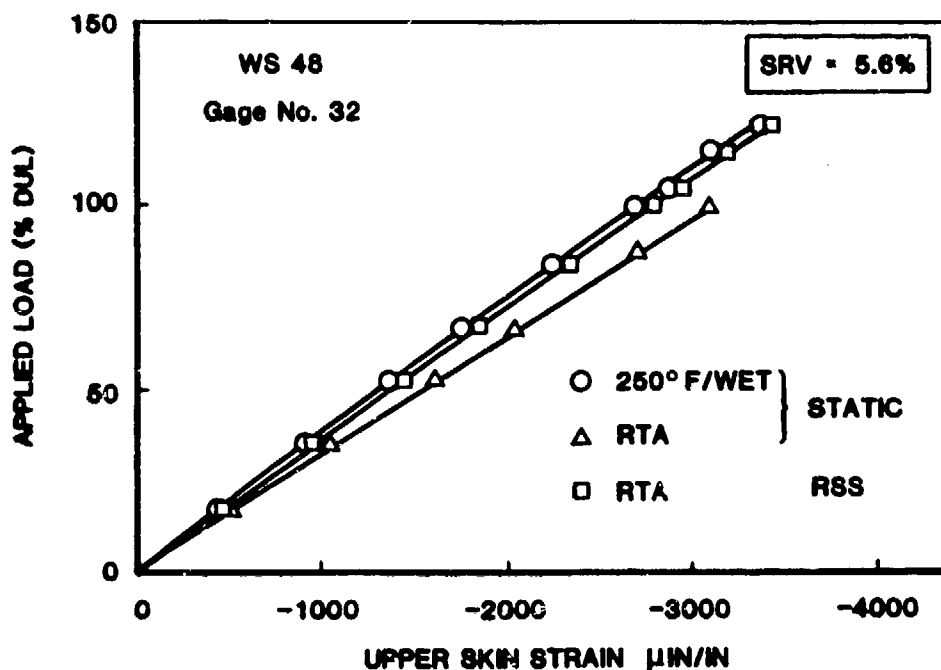

FIGURE 63. WCC-1 UPPER SKIN LOAD-STRAIN RESPONSE AT WING STATION 48 (GAGE NUMBER 32) FOR LOAD CASE 130.

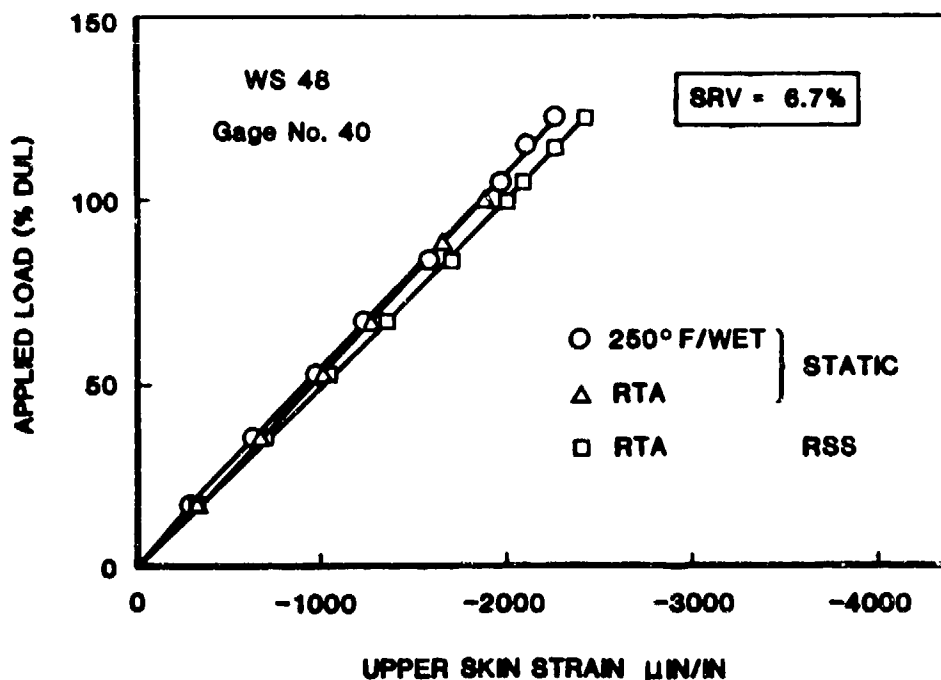

FIGURE 64. WCC-1 UPPER SKIN LOAD-STRAIN RESPONSE AT WING STATION 48 (GAGE NUMBER 40) FOR LOAD CASE 130.

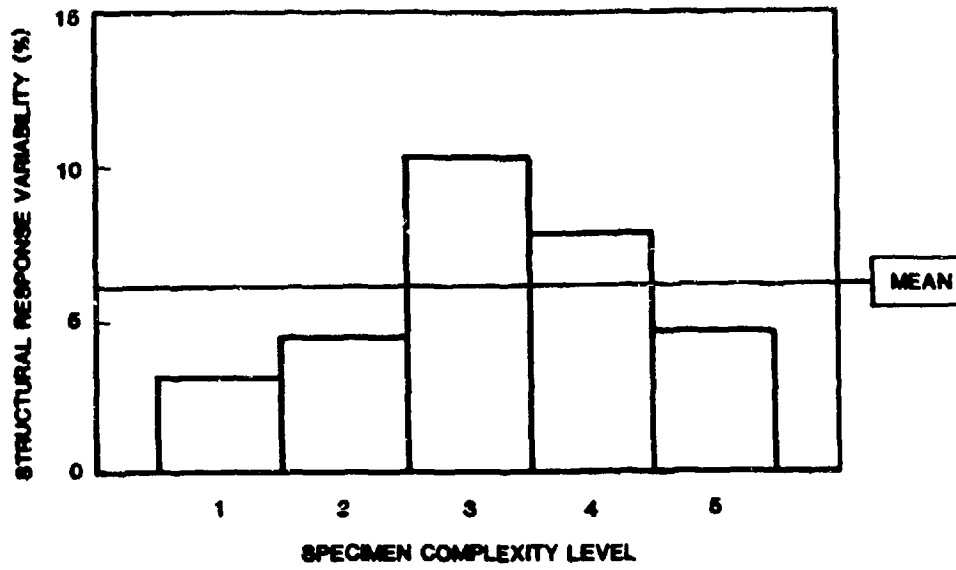

FIGURE 65. INFLUENCE OF SPECIMEN COMPLEXITY LEVEL ON RTA STRUCTURAL RESPONSE VARIABILITY.

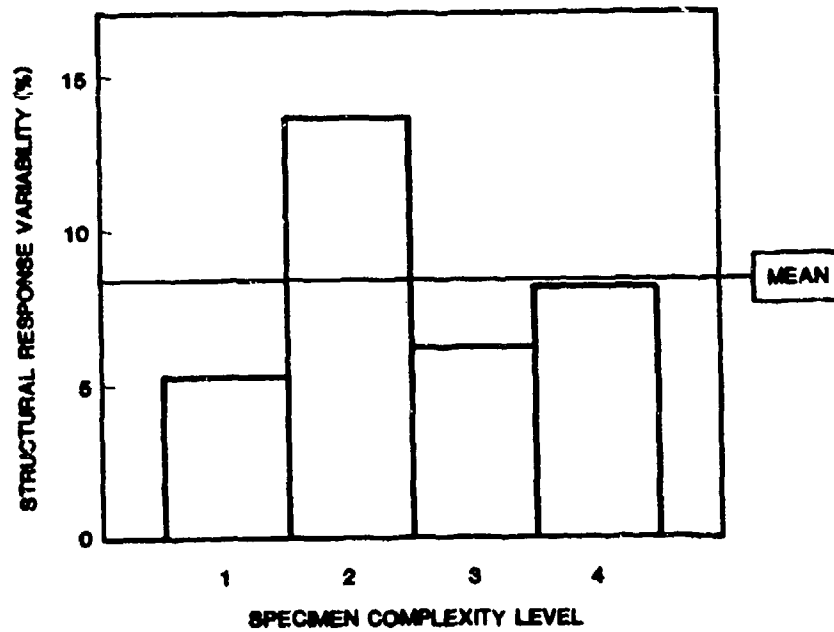

FIGURE 66. INFLUENCE OF SPECIMEN COMPLEXITY LEVEL ON ETW STRUCTURAL RESPONSE VARIABILITY.

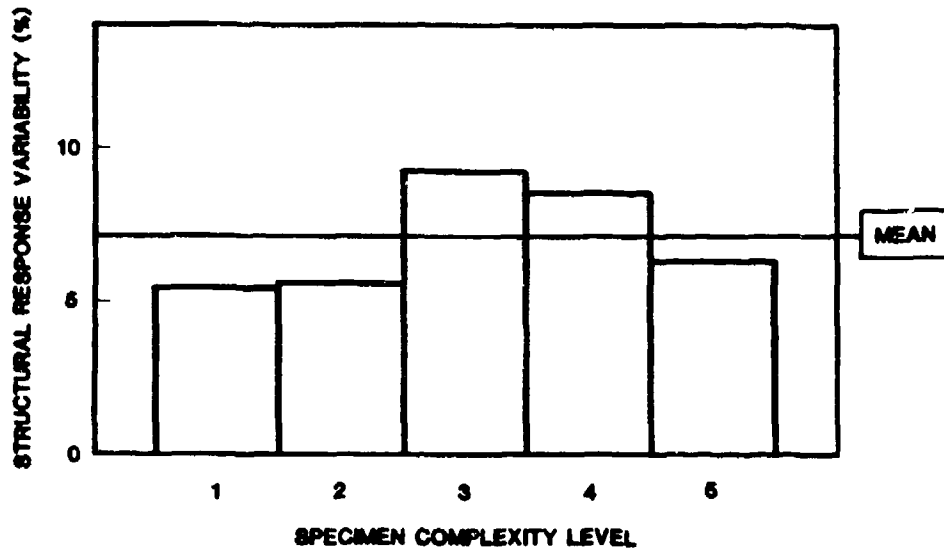

FIGURE 67. INFLUENCE OF SPECIMEN COMPLEXITY LEVEL ON COMBINED RTA AND ETW STRUCTURAL RESPONSE VARIABILITY.

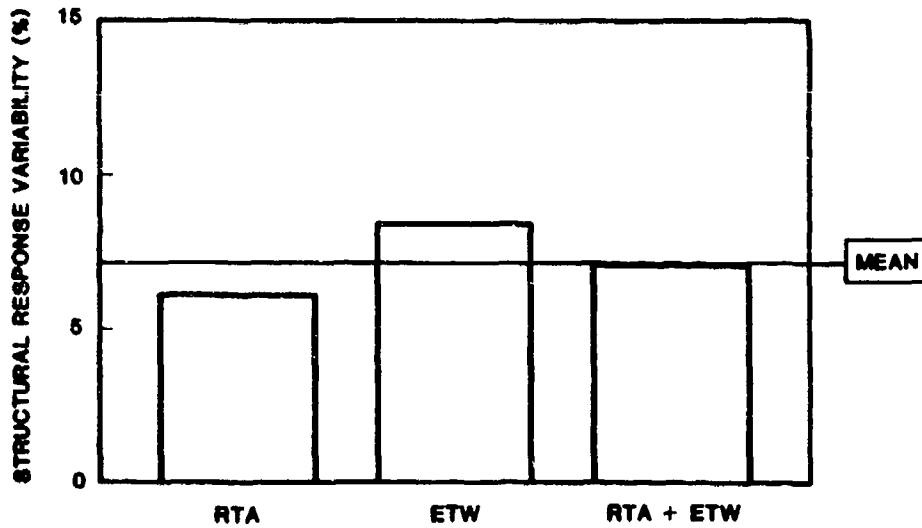

FIGURE 68. INFLUENCE OF ENVIRONMENT ON STRUCTURAL RESPONSE VARIABILITY.

The observed differences between the individual structural response variability at each complexity level and the overall mean for all complexity levels are not statistically significant. Consequently, it can be concluded that structural response variability is independent of specimen complexity. This is an encouraging observation for the certification of full-scale structure. It is interesting to note that the scatter in static strength data in Reference 5 was also found to be independent of specimen complexity.

Figure 68 shows the influence of environment on structural response variability. It can be seen that structural response variability is also independent of test environment. The structural response variability of wing component skin strain distributions is shown in Figures 69 through 71. A comparison of structural response variability of the load-strain distributions is shown in Table 7. The results show that the structural response variability in strain distribution is similar to that observed previously for load-strain response.

The WCC-1 structural response variability results presented in Table 6 were determined for static loading case 130. This is the most critical loading case for the wing. Prior to the five static and fatigue tests conducted on the wing component specimens in Reference 5, load-strain surveys were conducted to limit load for five critical loading cases. These are shown in Table 8. All the load-strain surveys were conducted under RT/ambient conditions. Table 9 summarizes the wing component tests where these RT/Ambient load-strain surveys were conducted prior to test. The influence of loading case on structural response variability are shown in Figures 72 through 76 for a strain gage located on the upper skin close to the root rib.

Table 10 and Figure 77 present a summary of the influence of loading case on structural response variability. The results in Table 10 show that the influence of loading case on structural response variability is similar for all four strain gage locations. In addition, Figure 77 shows that the loading

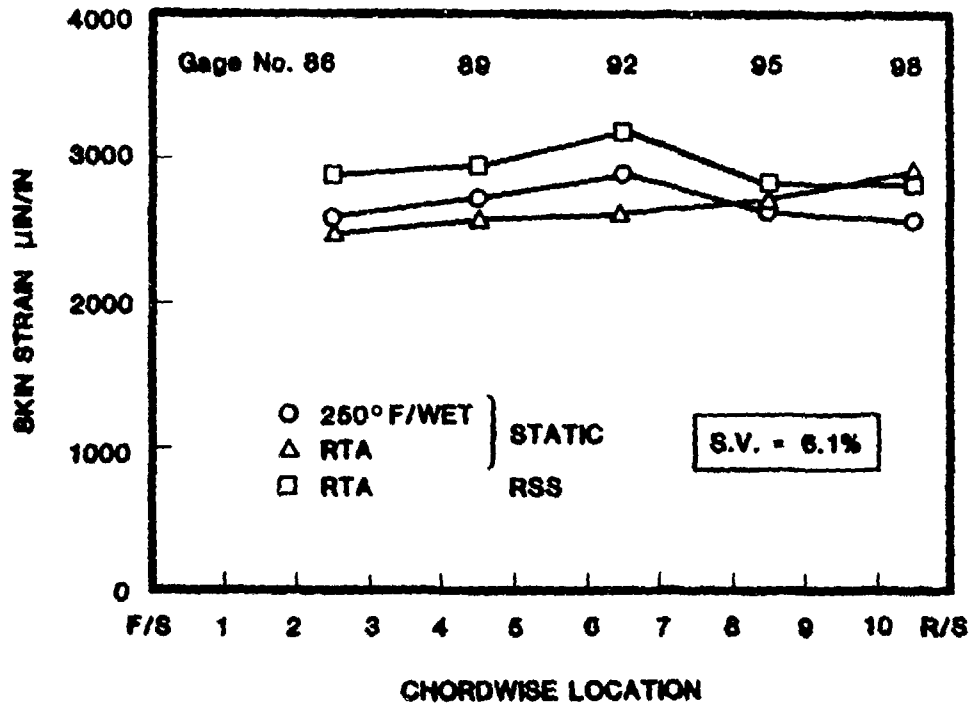

FIGURE 69. WCC-1 DESIGN ULTIMATE LOAD LOWER SKIN STRAIN DISTRIBUTION AT WING STATION 43 FOR LOAD CASE 130.

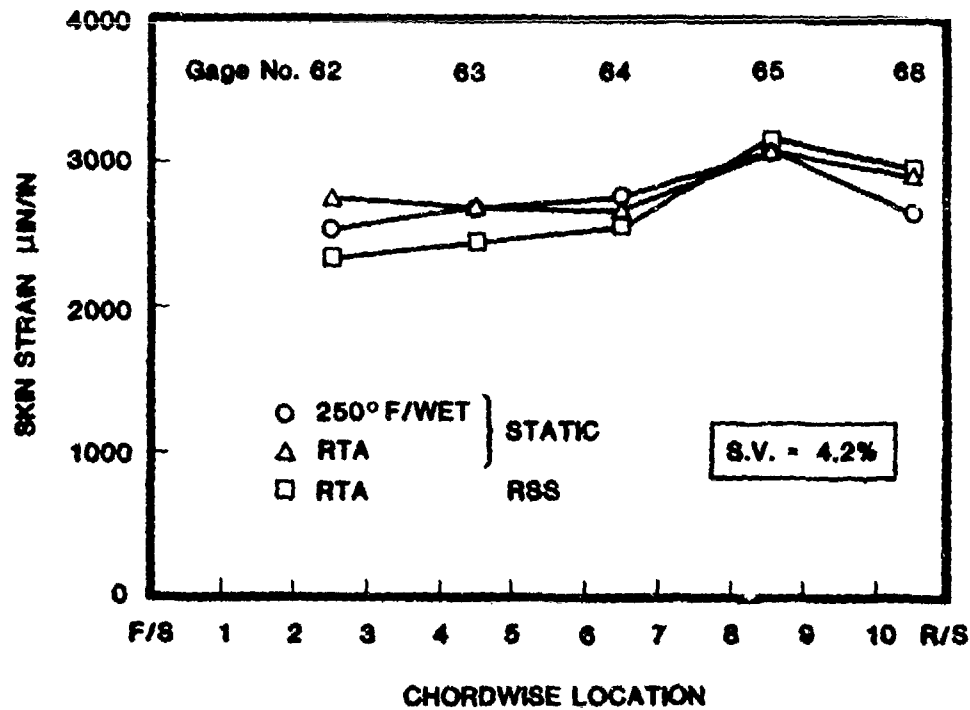

FIGURE 70. WCC-1 DESIGN ULTIMATE LOAD LOWER SKIN STRAIN DISTRIBUTION AT WING STATION 85 FOR LOAD CASE 130.

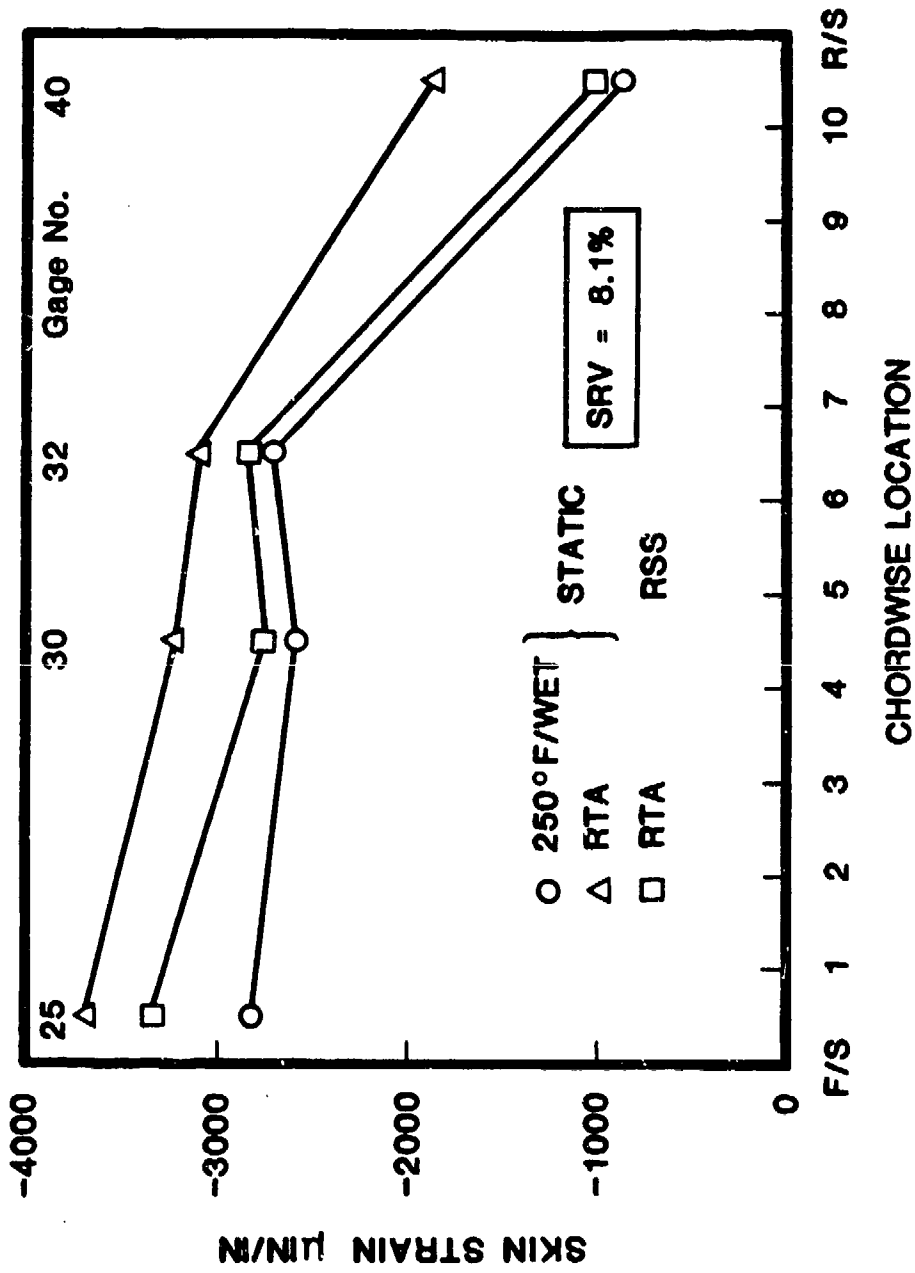

FIGURE 71. WCC-1 DESIGN ULTIMATE LOAD UPPER SKIN STRAIN DISTRIBUTION AT WING STATION 48 FOR LOAD CASE 130.

TABLE 7. COMPARISON OF WCC-1 LOAD-STRAIN AND STRAIN DISTRIBUTION STRUCTURAL RESPONSE VARIABILITY.

LOCATION	STRUCTURAL RESPONSE VARIABILITY	
	LOAD-STRAIN AVERAGE	STRAIN DISTRIBUTION
LOWER SKIN WS 48	5.8	6.1
LOWER SKIN WS 85	4.7	4.2
UPPER SKIN WS 48	7.5	8.1

TABLE 8. SUMMARY OF WCC-1 ULTIMATE STATIC LOAD CASES.

LOAD CASE	DESCRIPTION	TEMPERATURE °F	S _z LB	M _x x 10 ⁻⁶ IN-LB	M _y x 10 ⁻⁶ IN-LB
100	SYMMETRICAL PULL-UP	145	173,000	11.7	-8.4
110	SYMMETRICAL PULL-UP	192	166,500	11.5	-7.7
130	SYMMETRICAL PULL-UP	242	140,000	10.3	-6.0
201	ROLLING PULL-UP	192	146,000	10.3	-7.4
102	SYMMETRICAL PUSHOVER	145	-57,600	-4.3	+1.8

NOTES:

- (1) S_z is the shear from the left wing tip to the root rib.
- (2) M_x is the left-hand wing moment at the root rib.
- (3) M_y is the wing torsion.

TABLE 9. WING COMPONENT (WCC-1) TESTS IN REFERENCE 5.

TEST SERIES	TEST TYPE
1	250°F/WET STATIC
2	RT/AMBIENT STATIC
4	RT/AMBIENT FATIGUE (2 LIFETIMES)
6	BASELINE ENVIRONMENTAL FATIGUE (2 LIFETIMES)
9	REAL TIME FATIGUE (1 LIFETIME)

TABLE 10. INFLUENCE OF LOADING CASE ON LOAD-STRAIN STRUCTURAL RESPONSE VARIABILITY.

GAGE No.	LOCATION	STRUCTURAL VARIABILITY IN LOAD-STRAIN RESPONSE (C.V.%)					
		CASE 100	CASE 110	CASE 130	CASE 102	CASE 201	MEAN
65	LOWER SKIN	6.1	5.4	4.3	14.5	5.4	7.1
86	LOWER SKIN	7.3	6.8	6.8	7.6	7.9	7.3
92	LOWER SKIN	6.5	6.8	7.2	7.0	6.9	6.9
25	UPPER SKIN	6.4	6.2	6.3	6.4	7.1	6.5
MEAN		6.6	6.3	6.2	8.9	6.8	7.0

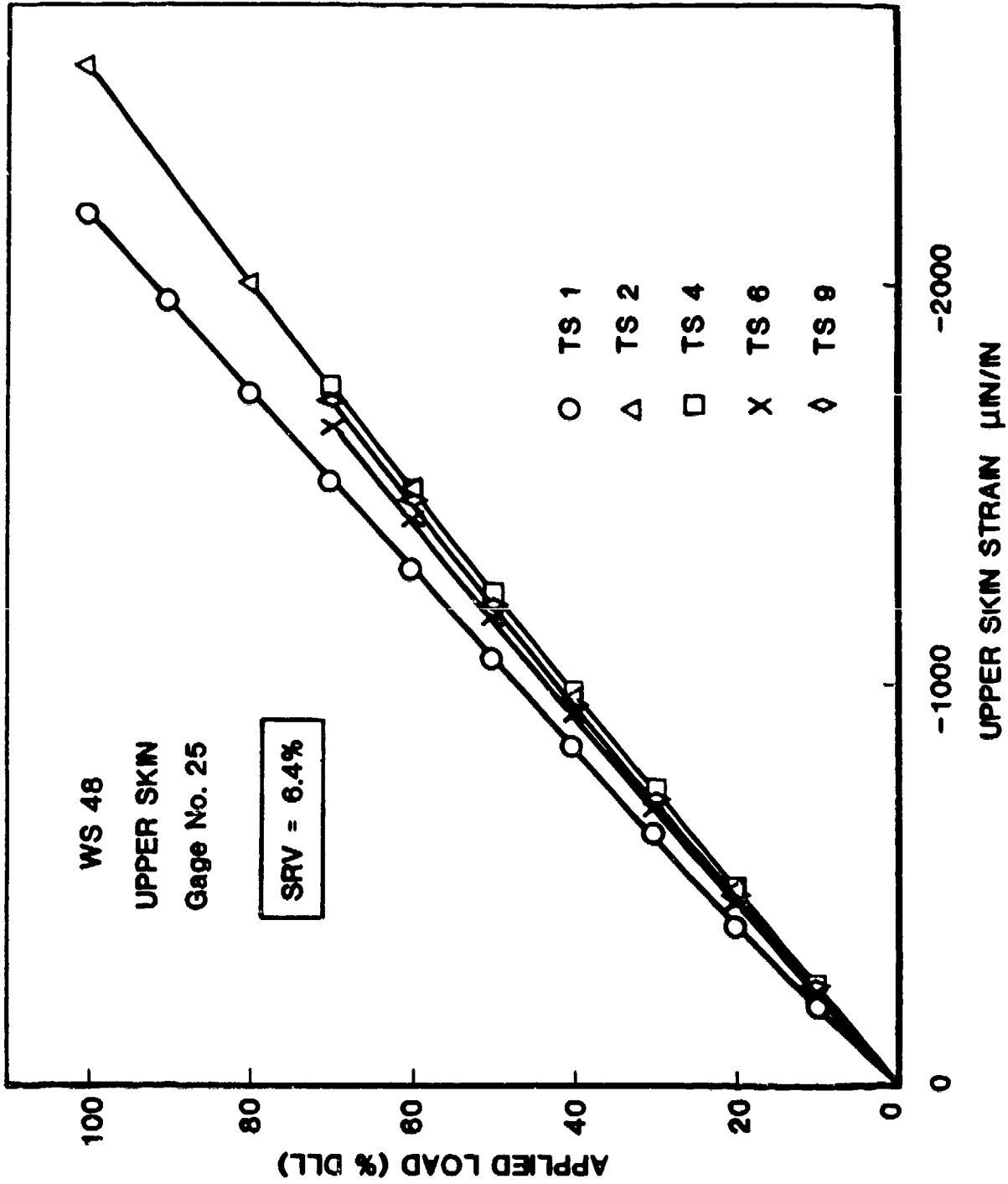

FIGURE 72. WCC-1 LOAD-STRAIN RESPONSE FOR LOAD CASE 100.

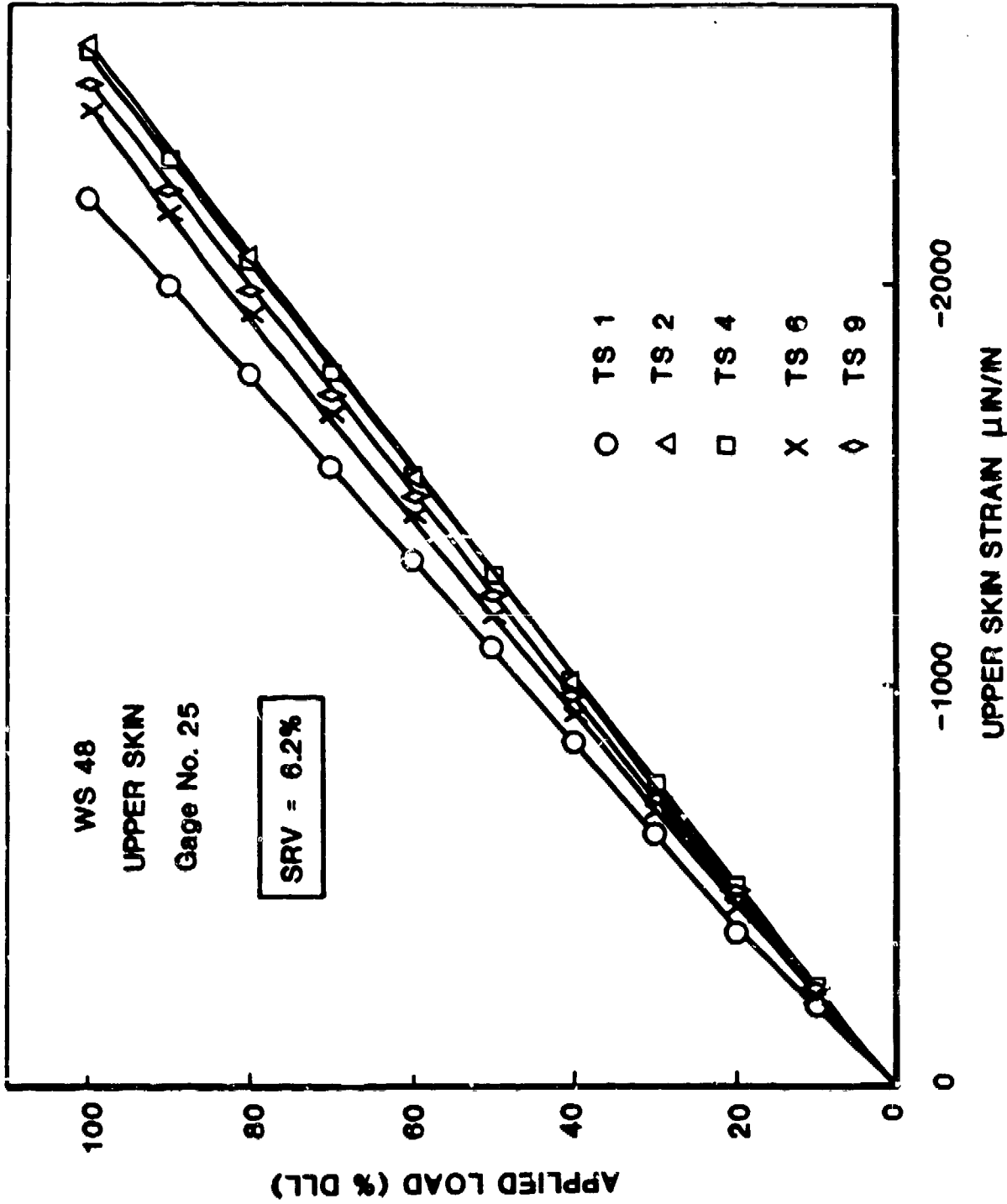

FIGURE 73. WCC-1 LOAD-STRAIN RESPONSE FOR LOAD CASE 110.

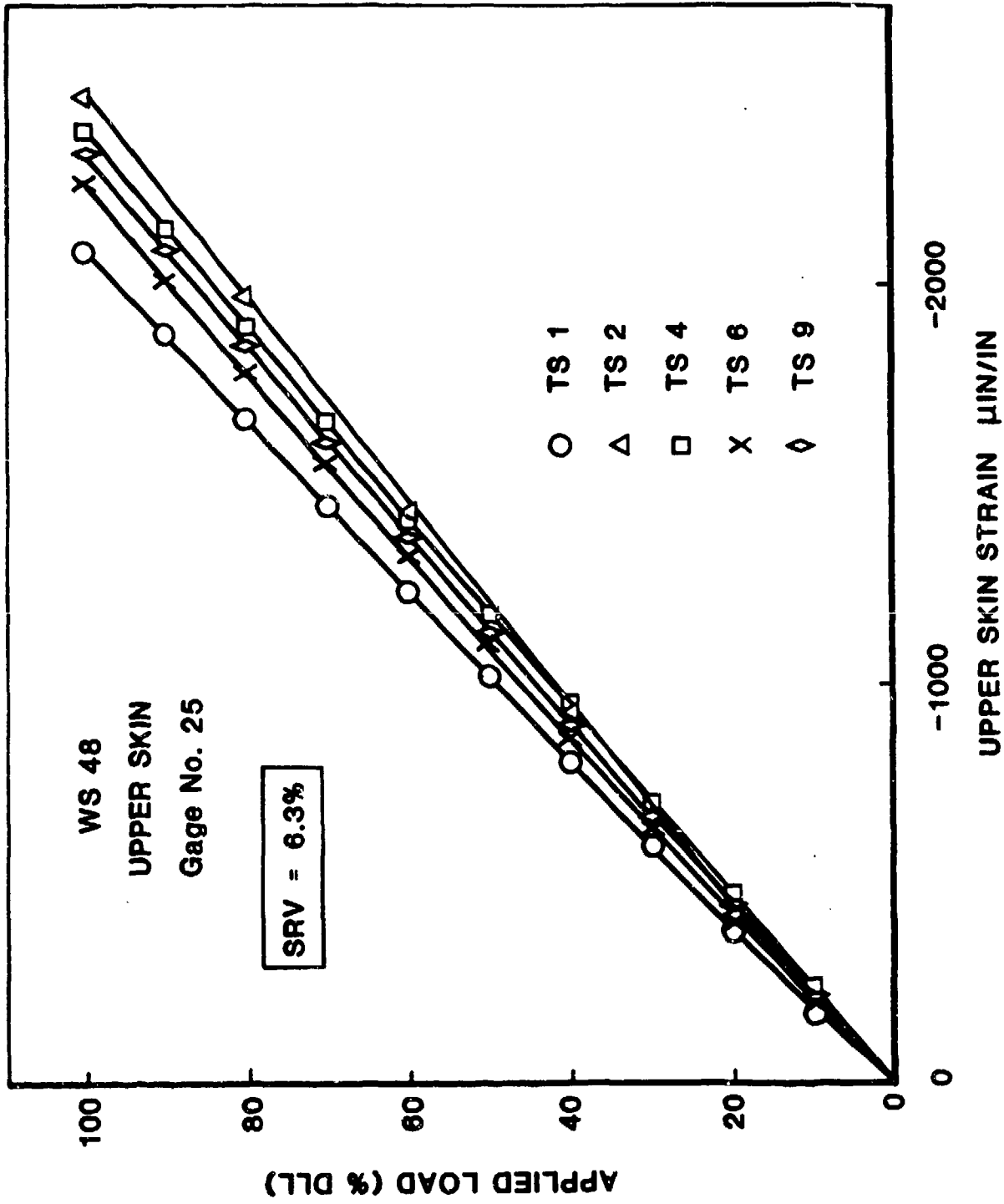

FIGURE 74. WCC-1 LOAD-STRAIN RESPONSE FOR LOAD CASE 130.

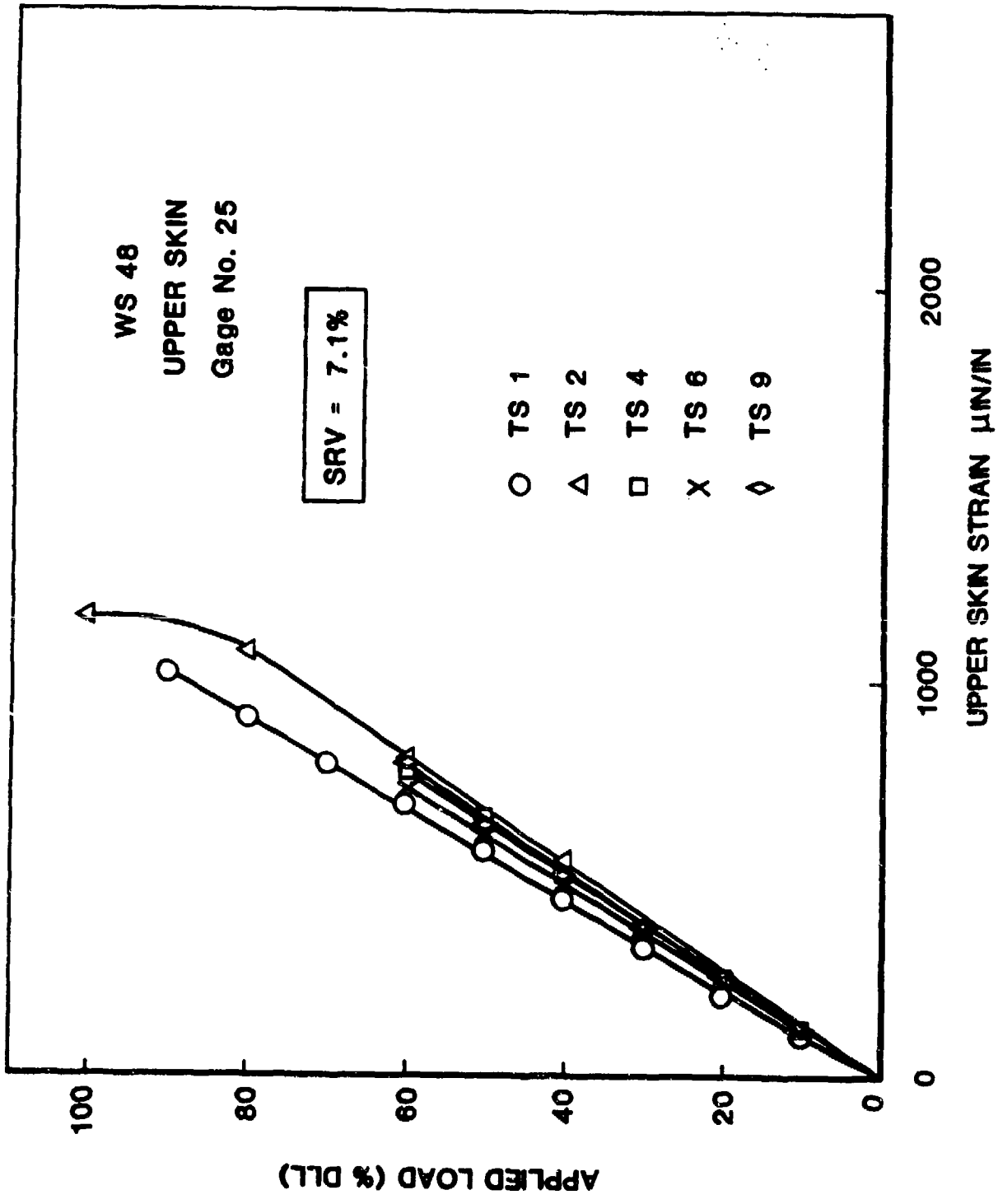

FIGURE 75. WCC-1 LOAD-STRAIN RESPONSE FOR LOAD CASE 102.

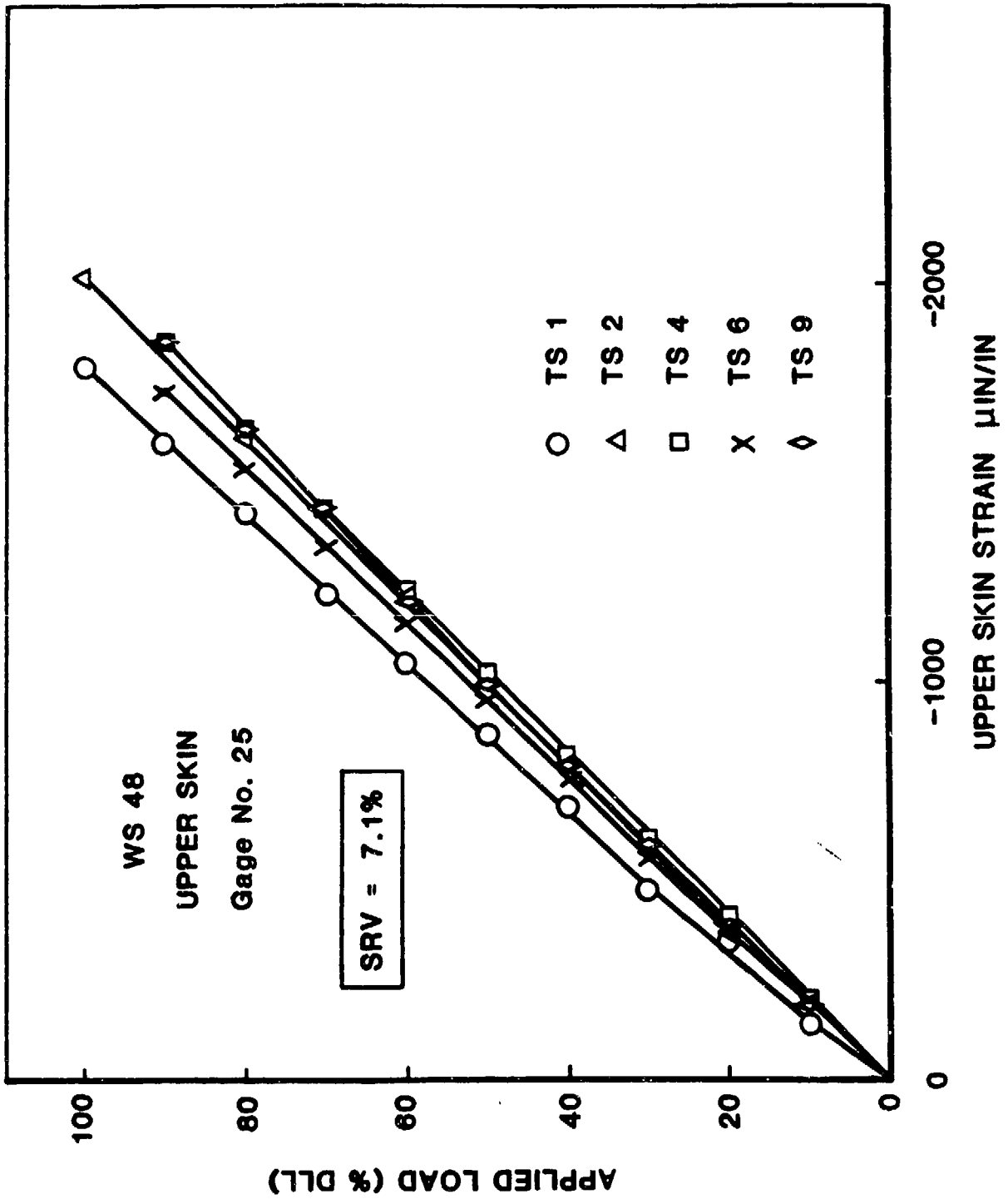
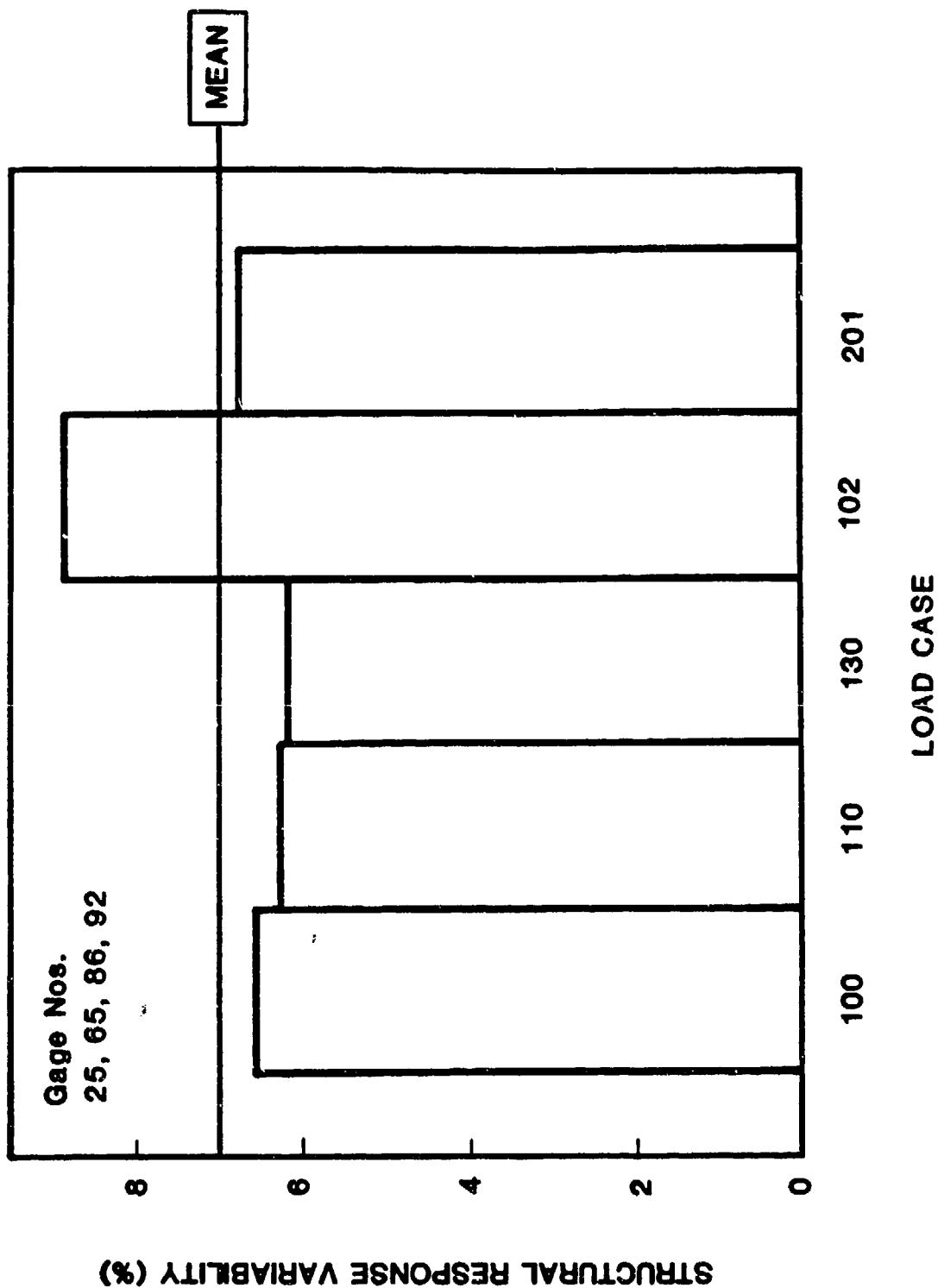

FIGURE 76. WCC-1 LOAD-STRAIN RESPONSE FOR LOAD CASE 201.



Gage Nos.
25, 65, 86, 92

MEAN

FIGURE 77. INFLUENCE OF LOADING CASE ON STRUCTURAL RESPONSE VARIABILITY.

case has little influence on structural response variability. Some increased variability is observed for the pushover (down-bending) load case 102. This is probably due to the low values of strain recorded at limit load. However, none of the five loading cases exhibited values of structural response variability that were significantly different from the overall mean value of 7.0 percent. This overall value is very similar to the overall mean value of 7.1 percent determined for all specimens in Table 6.

An interesting observation can be made from the load-strain data in Figures 72 through 76. The scatter trend in the data is the same for all loading cases. That is, Test Series 1 gives the lowest strain at design limit load, while Test Series 2 and 4 give the highest strains at design limit load. This observation was true for all four strain gage locations that are analyzed.

Since the structural response variability was found to be independent of structural complexity, environment and loading case, all data in Table 6 are pooled. The pooled data are analyzed using a normal distribution and the resultant scatter distribution is shown in Figure 78. The following values of structural response variability are determined:

(SRV)MEAN	= 7.1%	or	(α SRV)MEAN	= 17.36
(SRV)MODAL	= 6.5%	or	(α SRV)MODAL	= 19.02
(SRV)B-BASIS	= 9.5%	or	(α SRV)B-BASIS	= 12.81

Following the philosophy adopted for static strength and fatigue life scatter values, the modal structural response variability of 6.5 percent will be used for incorporation in the certification testing methodology.

Summary

A comprehensive analysis of a large load-strain data base has been conducted. A total of 360 separate load-strain plots containing in excess of 3000 individual data points are

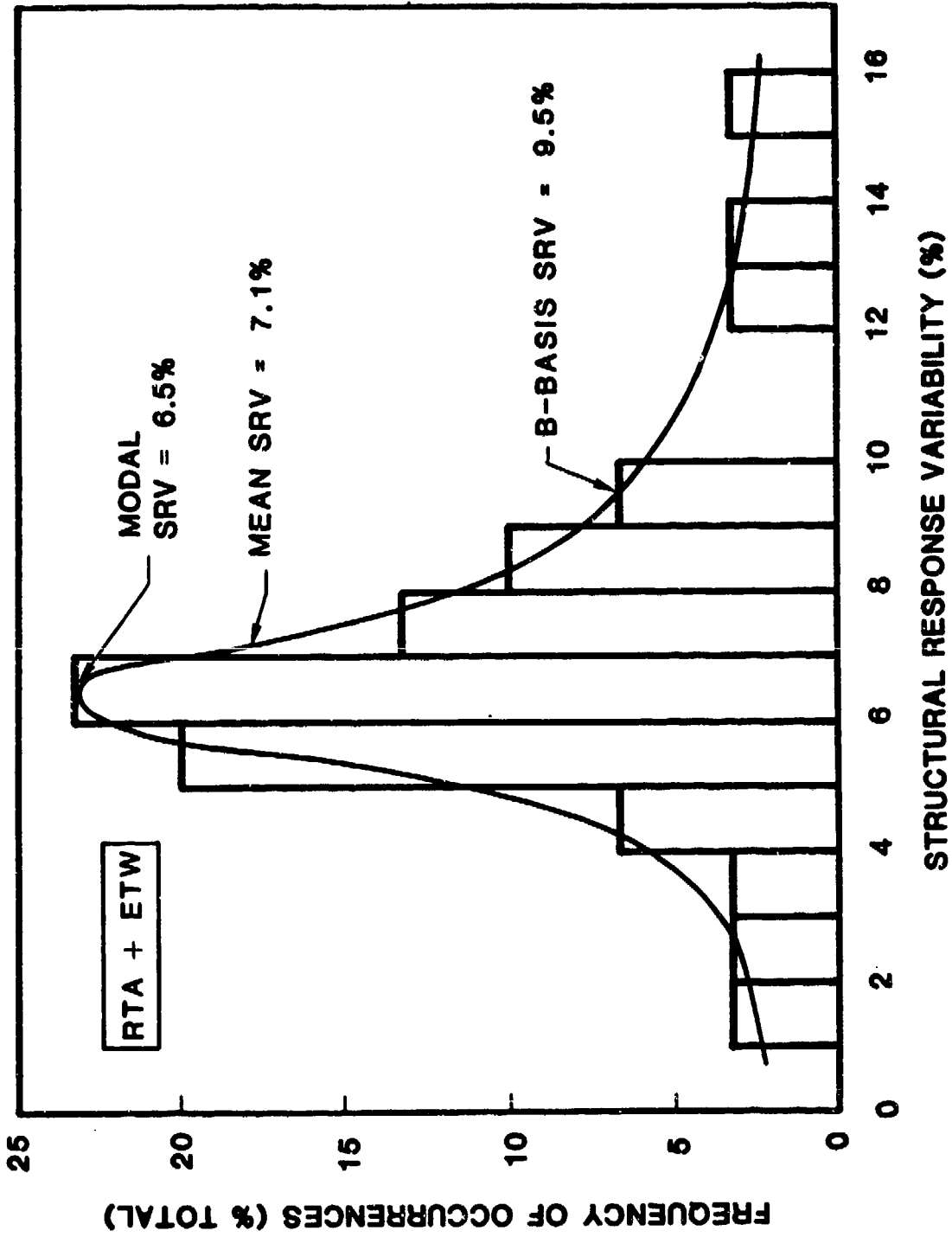

FIGURE 78. DISTRIBUTION OF STRUCTURAL RESPONSE VARIABILITY FOR COMBINED RTD + ETW LOAD-STRAIN DATA.

analyzed. A novel analysis technique permitted the determination of structural response variability from the load-strain data for the first time. The following conclusions can be made from the study.

- A statistical analysis methodology is developed to determine structural response variability from load-strain data.
- Structural response variability is shown to be independent of specimen complexity, test environment and static loading cases.
- The structural response variability of load-strain and strain distributions is approximately equal.
- The mean and modal values of structural response variability are 7.1 and 6.5 percent, respectively.

3.3 Usage Variation

The differences between the fatigue response of metallic and composite materials were discussed in Section 2. It was concluded that current graphite-epoxy systems have a significantly superior fatigue response, as shown in Figure 43. This causes a different response to usage changes for the two materials. Consider, for example, a usage change, which is more severe than the design spectrum, and leads to an effective increase in operating stress level relative to the design stress level. Figure 79 summarizes the change in fatigue life as a function of this type of increased usage severity (σ_U/σ_D). It can be seen that increased usage severity causes a gradual reduction in metal design fatigue life. In contrast, increased usage severity initially has no effect on composite design fatigue life. Further increase in usage severity eventually causes very rapid reductions in composite design fatigue life. This behavior is caused by the flat S-N behavior of composites. The design stress level is significantly below the composite fatigue limit (defined as a very long life) such that increased usage severity does not initially change the design life. When severe usage changes

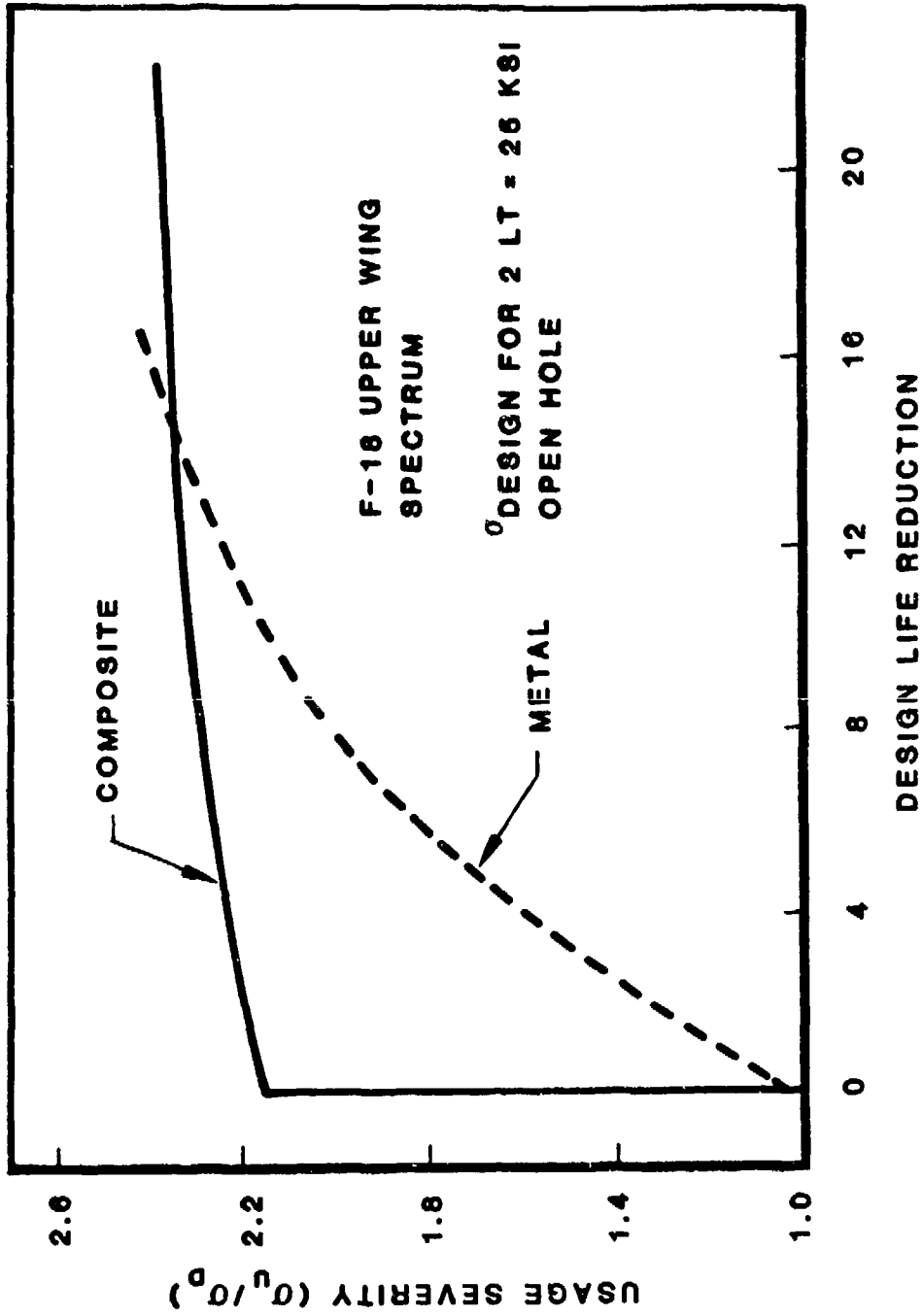

FIGURE 79. COMPARISON OF USAGE SEVERITY CHANGE FOR COMPOSITES AND METALS.

cause the operating stress level to intersect the composite S-N curve rapid life changes occur.

The maximum spectrum load in the actual service environment often deviates from the design load. The maximum load in a fatigue spectrum is a random variable in nature, and its probabilistic distribution can be described by a distribution function. This distribution function in conjunction with the fatigue life distribution and the fatigue wear-out law can be used to assess the influence of usage change on structural reliability. One approach is to assume the forms of the distribution function for the service load variation and the fatigue life distribution, together with an assumed wear-out equation to form a joint probability function. This is illustrated in Figure 80. These functions are selected and given below:

- (1) The composite fatigue life scatter is described by a Weibull distribution with probability of survival given by

$$P_L = \exp \left[- \left(\frac{x}{\beta_L} \right)^{\alpha_L} \right] \quad (27)$$

- (2) The stress-life relationship can be described by the wear-out equation from Sendeckyj analysis

$$\left(\frac{\sigma_u}{\sigma_a} \right)^{1/S} + C - 1 = CN \quad (28)$$

where σ_u is the static strength

σ_a is the maximum applied stress

C, S are wear-out parameters

N is the fatigue life at stress level σ_a

- (3) Two types of service load variation distribution, $f(\sigma)$, are assumed

a. Normal distribution with mean $\bar{x} = \sigma_a$ and standard deviations

b. Weibull distribution with shape and scale parameters α_u and β_u so that $\bar{x} = \sigma_a$

- DISTRIBUTION OF SERVICE LOAD VARIATION $f(\sigma)$

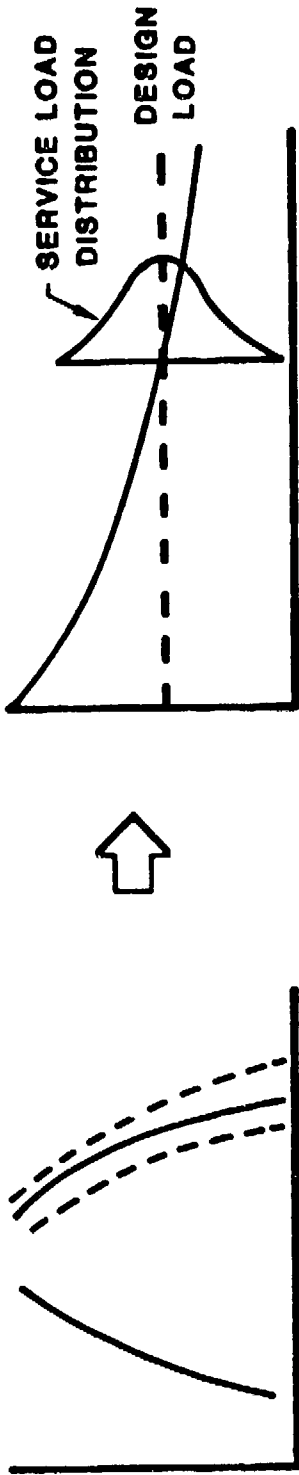

- FATIGUE LIFE SCATTER, $p_L(\sigma)$
- STRESS-LIFE RELATION (S-N CURVE)
- JOINT PROBABILITY FUNCTION



$$p_s = \int_0^{\infty} p_L(\sigma)f(\sigma)d\sigma$$

FIGURE 80. METHODOLOGY FOR INCORPORATING USAGE VARIATION INTO FATIGUE LIFE RELIABILITY CALCULATIONS.

or

$$\text{or } \beta_u = \frac{\sigma_a}{\Gamma\left(\frac{\alpha_u + 1}{\alpha_u}\right)} \quad (29)$$

The joint probability of survival for the structure is then given by

$$P_s = \int_0^{\infty} P_O(\sigma) f(\sigma) d\sigma \quad (30)$$

where $f(\sigma)$ is the probability density function of the service load distribution. The function $p_L(\sigma)$ is the probability of survival at stress level σ . Numerical integrations are conducted to evaluate the influence of usage change on fatigue reliability.

The parameters used in the numerical evaluation are given below:

1. Fatigue life variability, $\alpha_L = 1.25$
2. Design applied stress level, $\sigma_a = 0.8 \sigma_u$
3. Wear-out equation parameters, $S = 0.0625$ and $C = 0.03544$
4. Usage change variability, $\alpha_u = 10$ to 26

The influence of the usage variation on the structural life reliability is shown in Figure 81. The 95 percent confidence reliability with no usage variation is assumed to be 0.90 (B-basis). This figure shows that the fatigue reliability is significantly reduced due to usage variation. For a sample size of $n = 1$, the reliability reduces to 0.68 for α_u of 16. The results using a normal distribution to describe the usage variation are also shown in the figure for $n = 20$. As can be seen from the figure, the selection of distribution function has a very small effect on the resulting reliability. The 95 percent confidence reliability plotted against the coefficient of variation of usage change is shown in Figure 82.

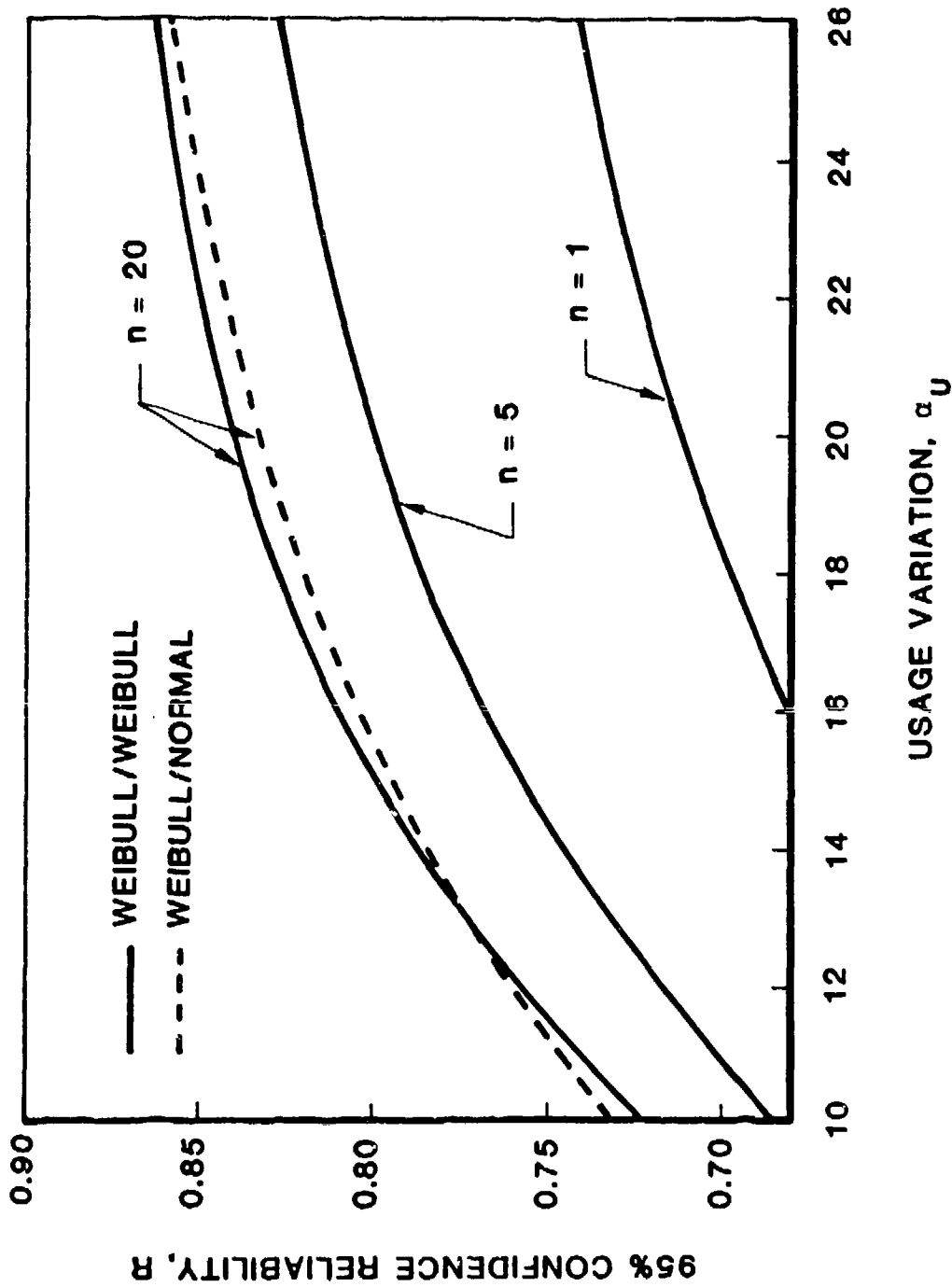

FIGURE 81. INFLUENCE OF USAGE VARIATION ON FATIGUE RELIABILITY
($\sigma_a / \sigma_u = 0.8$).

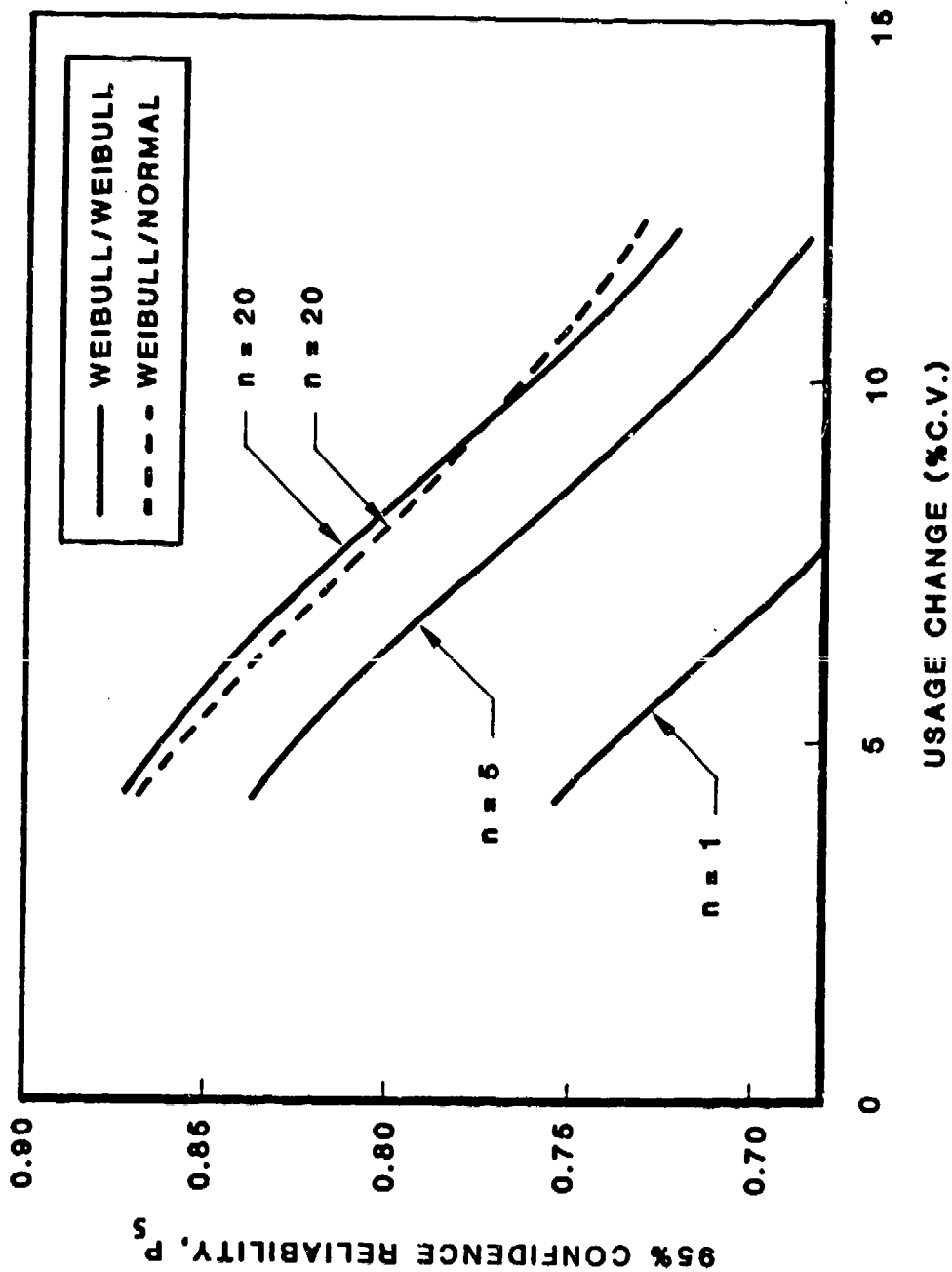

FIGURE 82. CHANGE OF RELIABILITY WITH USAGE VARIATION.

The influence of usage variation on the B-basis fatigue life is shown in Figure 83. The figure shows that the B-basis fatigue life is significantly reduced by usage variation. For a sample size of $n = 1$, the B-basis life is computed to be 133 hours when usage variation is not considered. The B-basis life becomes 54 hours for $\alpha_u = 26$ and is reduced to 17 hours when $\alpha_u = 10$. The mean life to B-basis life ratio (life factor) is shown in Figure 84. This figure shows that the life factor is increased significantly as the usage variation increases (decreasing α_u). The life factor for $n = 1$ with no usage variation is 13.55. It becomes 18 when $\alpha_u = 26$ and increased to 38.3 as $\alpha_u = 12$.

It should be noted that the methodology developed for usage variation effects can also be used to determine the effects of structural response variability on the fatigue life reliability. In this case, the probability density function $f(\sigma)$ in Equation 27 is replaced by the density function for SRV and the analysis procedure is identical. This analysis technique is used for methodology demonstration discussed in Section 4.

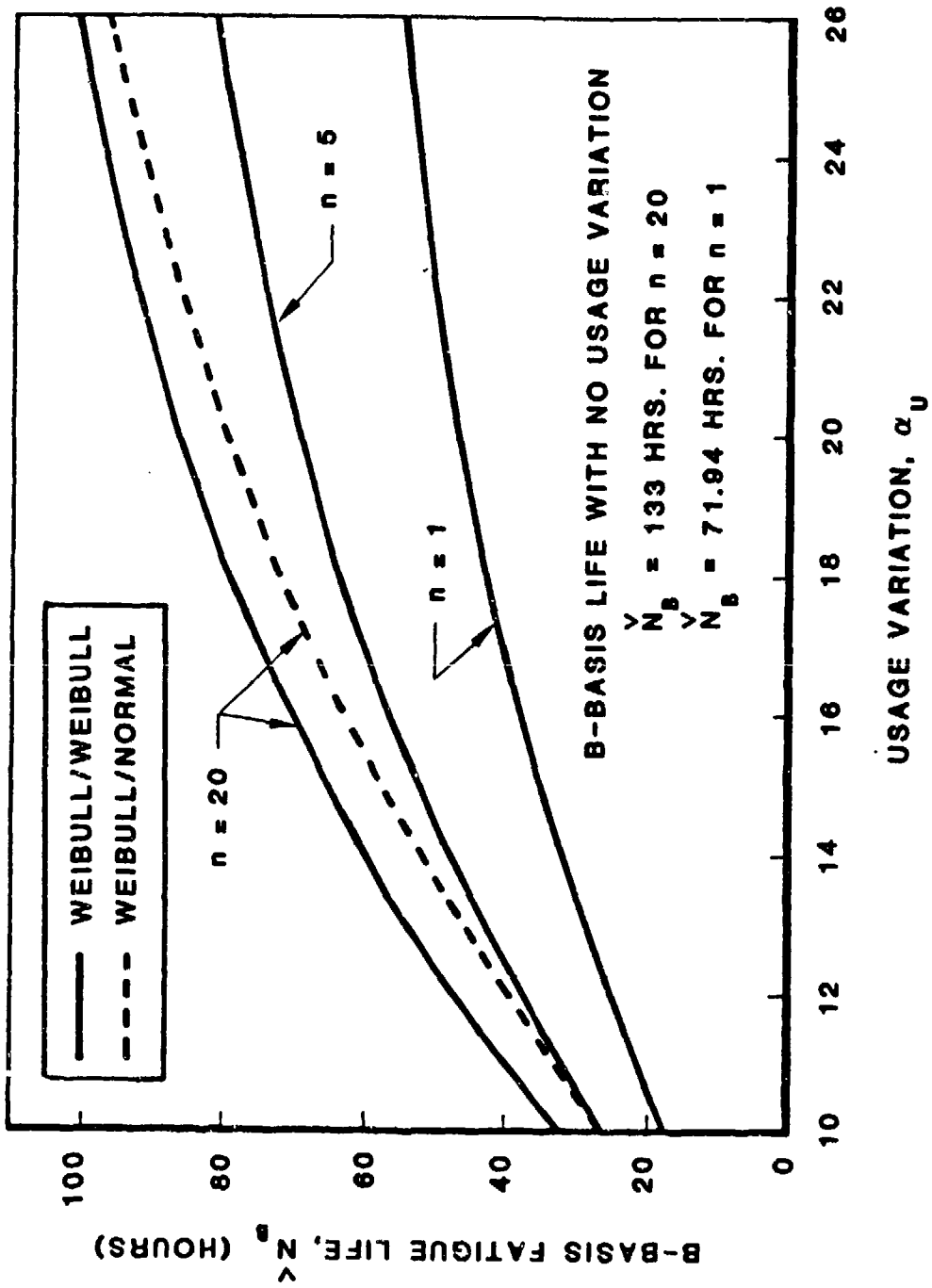

FIGURE 83. EFFECTS OF USAGE VARIATION ON THE B-BASIS LIFE.

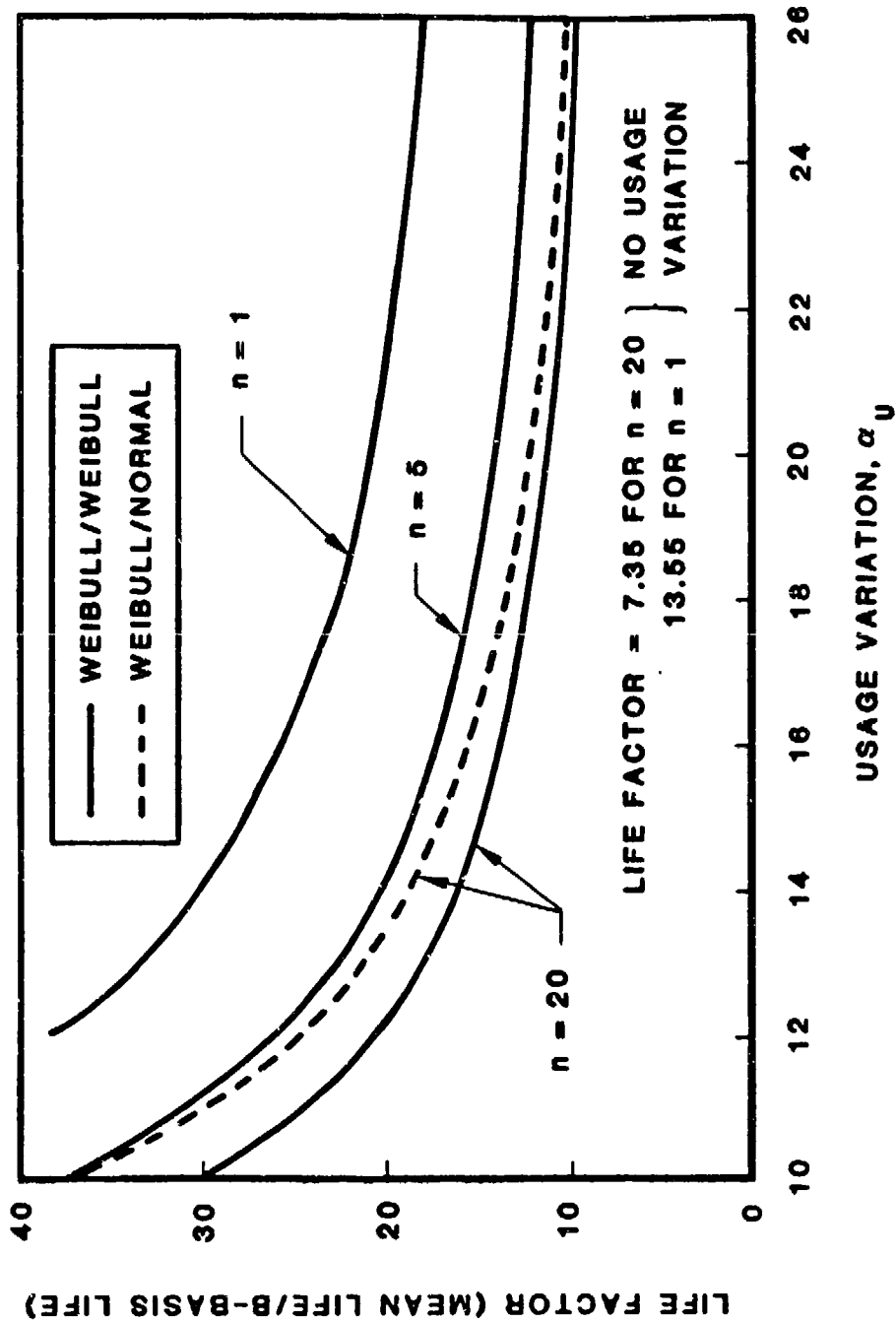

FIGURE 84. EFFECTS OF USAGE VARIATION ON B-BASIS FATIGUE LIFE FACTOR.

SECTION 4METHODOLOGY DEMONSTRATION

The full scale wing and fuselage components from the Composite Wing/Fuselage Program (Reference 5) are selected as the primary demonstration articles. An extensive design development and full scale test data base was generated in this program. These data are reevaluated using the methodology developed in Sections 2 and 3. Static and fatigue margins of safety and reliabilities are established from this evaluation. Results of this evaluation are summarized in this section. Evaluations of the wing component (WCC-1) and fuselage component (FCC-1) are discussed in full detail.

4.1 Composite Wing/Fuselage Program Data Base

Figure 57 summarizes the wing test specimens used in Reference 5. This figure also shows the building block approach used for design development testing. The design development testing is characterized by four levels of complexity. The fifth level of complexity is assigned to the full-scale component.

The wing skin coupon specimens represent the first complexity level in the building block approach and simulate single tension and compression failure modes. The second complexity level in the building block approach contains specimens WE-2 and WEC-1. Each of these specimens has two potential failure modes. WE-2 is an upper skin/rear spar mechanical joint designed to check the influence of load transfer on compression strength. Potential failure modes for this specimen are laminate failure or bearing failure at a fastener hole. The WEC-1 specimen is a lower skin/intermediate spar cocured joint designed to check spar web strength in the presence of a fuel drain hole and the cocured bonded joint under combined shear, fuel pressure and chordwise loading. Potential failure modes are web failure at the fuel drain hole and bondline failure in the cocured joint. The third complexity level in the building block approach is

represented by WEC-3, which is an intermediate spar/pylon rib transfer joint, and is designed to check load transfer from the discontinuous spar into the rib and back to the spar. This specimen combines the potential failure modes of the wing coupons and WEC-1, i.e., upper and lower skin failure at a rib attachment fastener hold, spar web failure and intermediate spar/lower skin failure in the cocured joint. The fourth and final level of complexity in the torsion box design development testing is represented by the wing subcomponent WS-1 which is a three bay box beam and WS-2 which represents the highly loaded root rib/aft trunnion area. All of the failure modes of the wing coupons, WE-2, WE-1 and WEC-3 are represented in the WS-1 specimen. In addition, an upper skin access hole provides a further potential failure mode. The fifth level of complexity is the wing component WCC-1 which is fully representative of the actual wing structure.

Table 11 summarizes the test matrix for the wing specimens. Two static tests were conducted under RT/ambient and 250°F/wet conditions, where wet was defined as end-of-lifetime moisture level. A similar building block approach was used for the fuselage structure. Figure 85 summarizes the fuselage test specimens. The test matrix for the fuselage specimens is shown in Table 12.

Five fatigue test schemes were also used; these are summarized in Figure 86. All fatigue tests were conducted to two lifetimes followed by a residual static strength test. Test series 4 was a conventional RT/ambient accelerated fatigue test. Test series 6, 10 and 11 were accelerated environmental fatigue tests of varying complexity. All specimens in these test series were moisture conditioned prior to fatigue testing. Test series 12 was the least complex of the three test schemes with a constant temperature of 145°F imposed along with the accelerated flight loads. Test series 11 was the next most complex scheme with thermal spikes to 250°F and 218°F added to the 145°F baseline temperature profile. Test series 6 was the most complex

TABLE 11. SUMMARY OF WING TEST MATRIX FROM REFERENCE 5.

SPECIMEN TYPE	STATIC TESTS		FATIGUE TESTS (TWO LIFETIMES)				
	RTA (TS2)	250'F/WET (TS1)	RTA (TS4)	ENVIRONMENTAL			REAL FLIGHT TIME (TS10)
				BASELINE (TS6)	ALTERNATE No. 1 (TS11)	ALTERNATE No. 2 (TS12)	
WC-1	10	10	10	3	3	-	-
WC-2	3	3	3	-	-	-	-
WC-3	10	10	10	3	3	-	-
WC-4	3	3	3	-	-	-	-
WC-5	3	3	3	-	-	-	-
WC-6	3	3	3	3	3	-	-
WE-1	3	3	3	-	-	-	-
WE-2	3	3	3	-	-	-	-
WEC-1	3	3	3	3	1	2	2
WEC-2	3	3	3	-	-	-	-
WEC-3	3	3	3	2	1	2	2
WS-1	3	3	3	2	1	2	2
WS-2	1	2	-	-	-	-	-
WCC-1	1	1	1	-	-	-	1

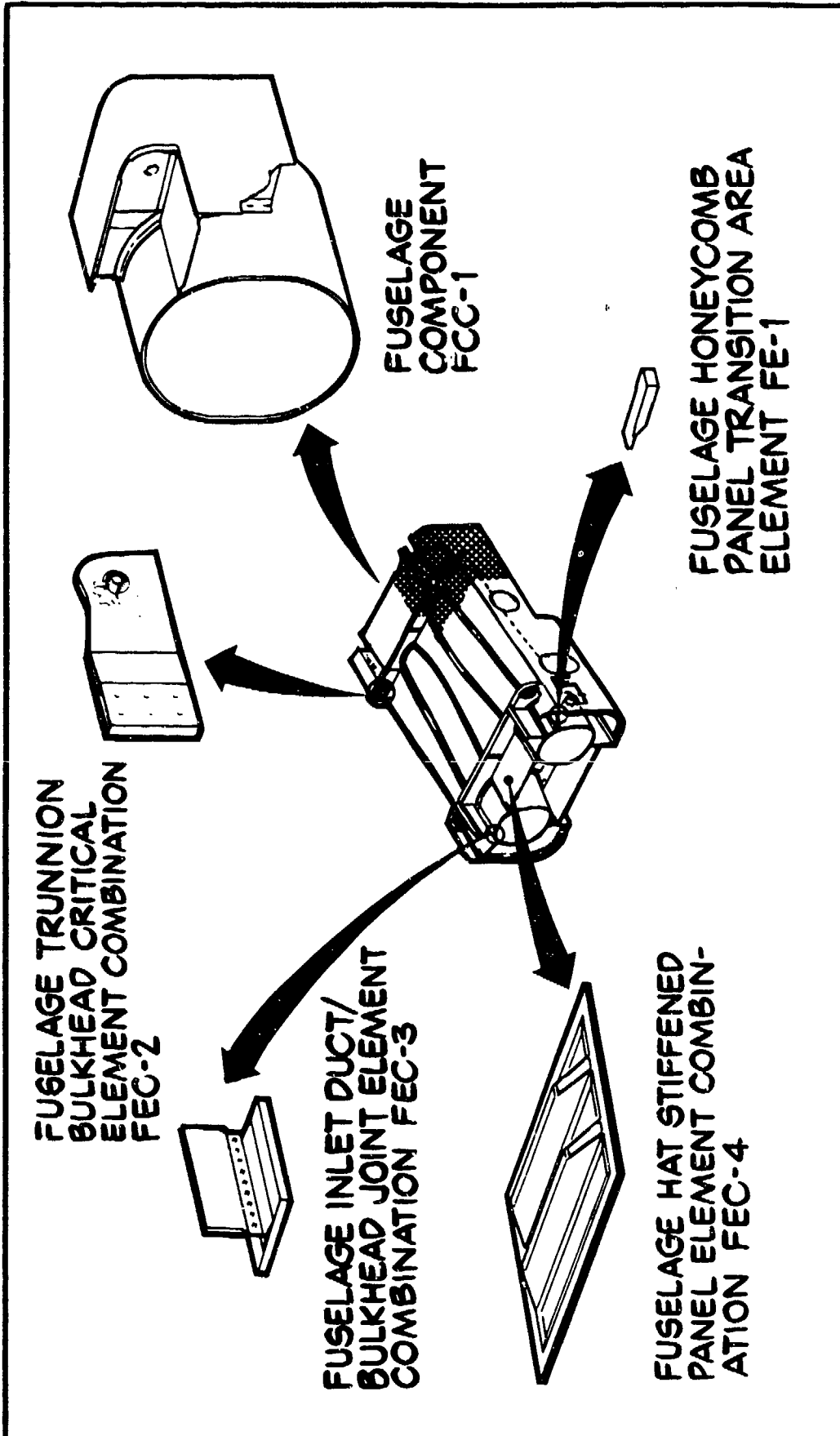

FIGURE 85. BUILDING BLOCK APPROACH FOR THE FUSELAGE STRUCTURE IN REFERENCE 5.

TABLE 12. SUMMARY OF FUSELAGE TEST MATRIX FROM REFERENCE 5.

SPECIMEN TYPE	STATIC TESTS			FATIGUE TESTS (TWO LIFETIMES)			
	RTA (TS 2)	250 F/WET (TS 1)	RTA (TS 4)	ENVIRONMENTAL			ALTERNATE No. 2 (TS 12)
				BASELINE (TS 6)	ALTERNATE No. 1 (TS 11)		
FE-1	3	3	3	3	3	3	3
FEC-2	3	3	3	3	-	-	-
FEC-3	3	2	3	2	-	-	-
FEC-4	2	3	3	3	-	-	-
FCC-1	1	1	1	-	-	-	-

- AMBIENT ACCELERATED
TS 4
- BASELINE ACCELERATED
TS 6
- ALTERNATE ACCELERATED NO.1
TS 11
- ALTERNATE ACCELERATED NO.2
TS 12
- REAL TIME / FLIGHT-BY- FLIGHT
TS 10

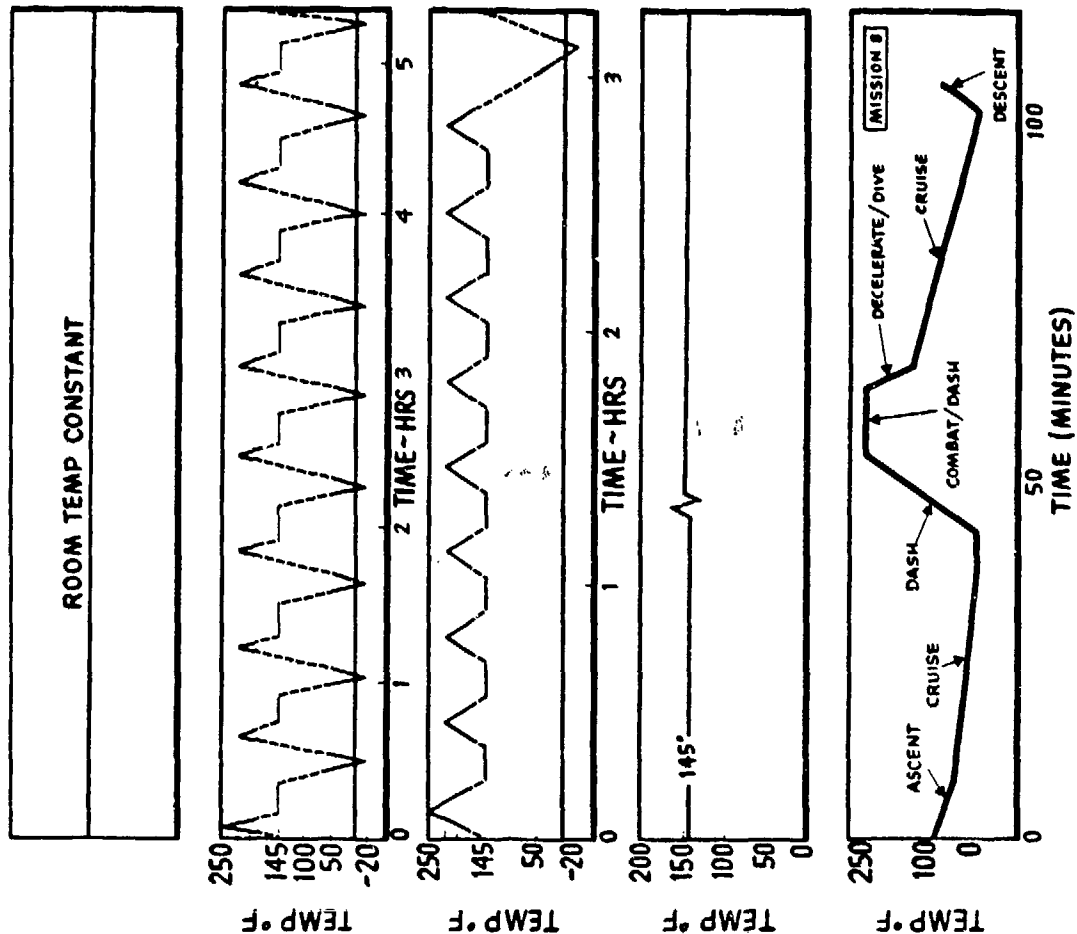

FIGURE 86. FATIGUE TEST SCHEMES USED IN REFERENCE 5.

accelerated environmental test scheme with thermal cycles ranging from -20 to 250°F. In addition, the complexity of test series 6 was increased by reconditioning test specimens during testing to replace moisture lost during thermal cycling. Test series 10 was a real flight time fatigue test, where flight loads and the associated temperature were applied to the actual rates seen by an aircraft. In addition, the moisture history of the test specimens was carefully simulated to match that seen in a 20 year service life.

Residual static strength tests after environmental fatigue loading (Test series 6, 10, 11 and 12) were conducted under the same 250°F/wet conditions as test series 1.

All testing shown in Table 11 is complete except for the real flight test on the Wing Component (WCC-1, Test Series 10). This test is in progress and has reached approximately one lifetime.

4.2 Wing Component (WCC-1) Data Evaluation

A detailed discussion of the wing component test results is given in Reference 20. The wing component with load introduction structure is shown in Figure 87 and the WCC-1 test set-up is shown in Figure 88. The most critical static design ultimate loads are shown in Table 13. A total of two static and two fatigue wing components were tested. The results are presented in Table 14. The static strength and fatigue life reliabilities of the component are determined based on the actual test data shown in Table 14. The results are discussed in the following paragraphs.

4.2.1 WCC-1 Static Test Data Evaluation

The static strength reliability is evaluated using the two-parameter Weibull distribution. The 95% confidence reliability of the component at DUL and DLL and the A- and B-basis static load are determined using the modal Weibull shape parameter $\alpha_S = 20.0$, for composite static data scatter (see Volume I). The effects of the structural response variation (SRV) are also

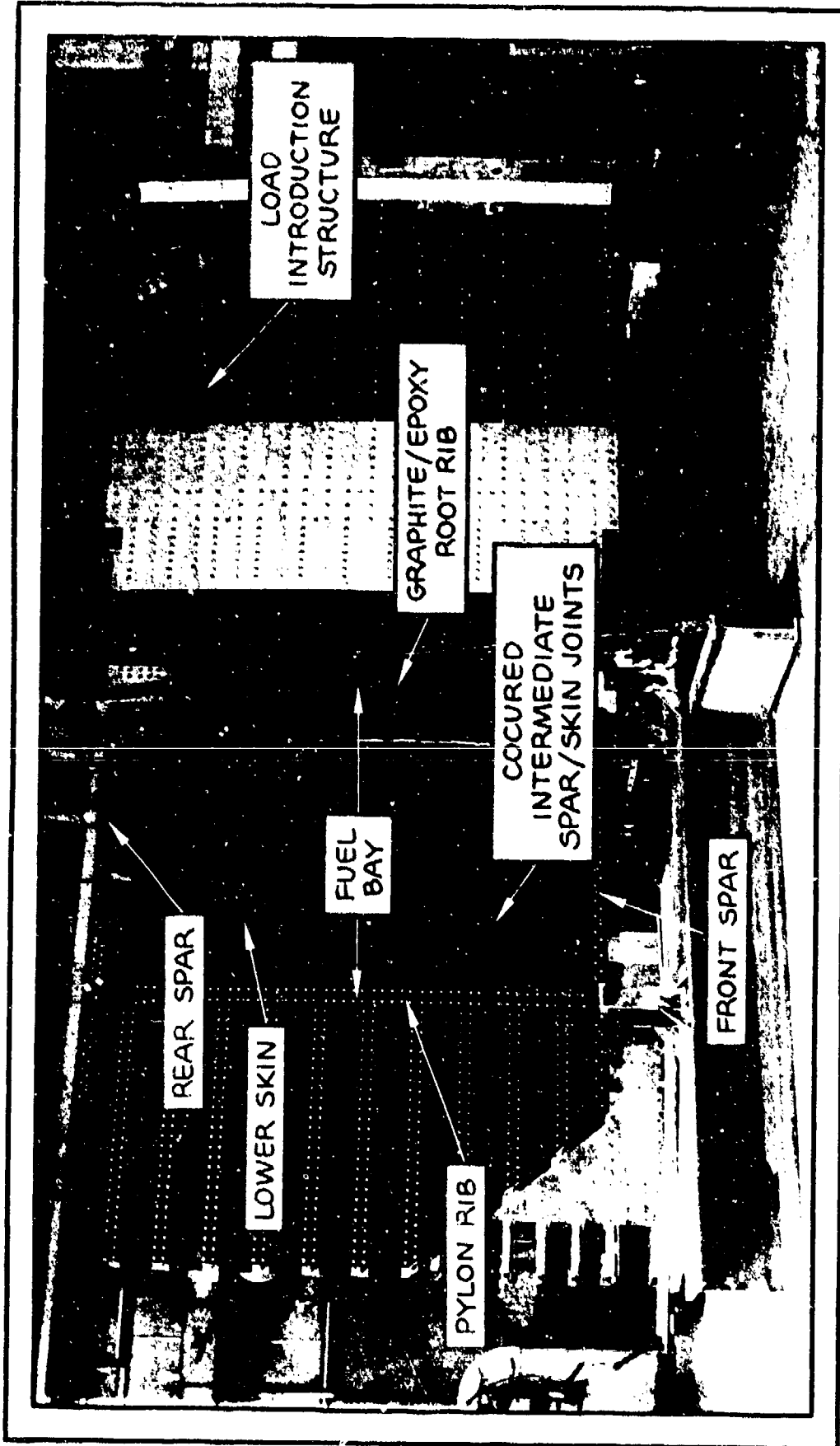

FIGURE 87. WING COMPONENT WITH LOAD INTRODUCTION STRUCTURE (REFERENCE 5)

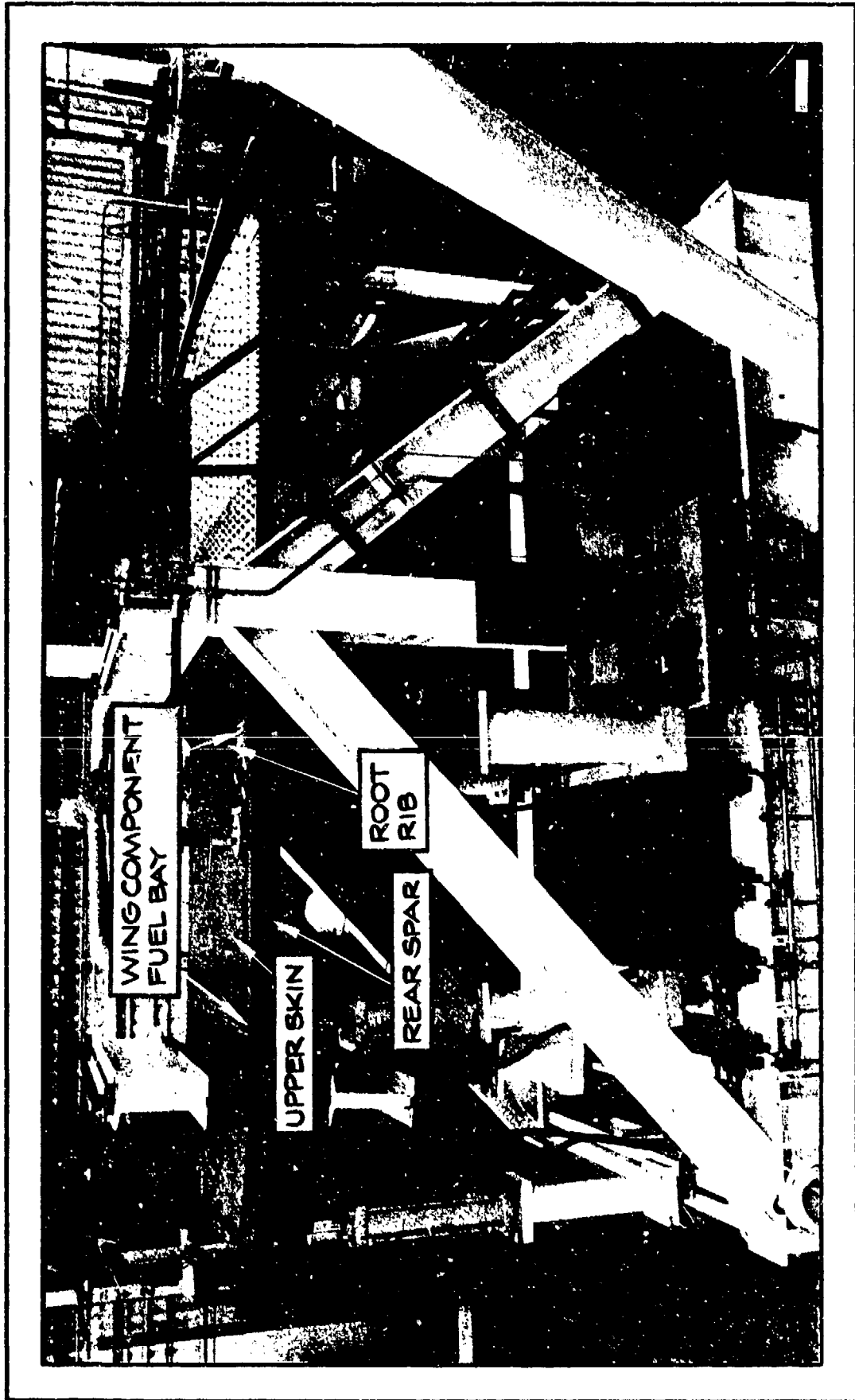

FIGURE 88. WCC-1 TEST SET-UP (REFERENCE 5).

TABLE 13. SUMMARY OF WING COMPONENT (WCC-1) STATIC DESIGN ULTIMATE LOADS.

CONDITION NUMBER	LOAD FACTOR N_z	TEMPERATURE °F	BENDING MOMENT IN-LB	TORQUE IN-LB	VERTICAL SHEAR LBS
130 *	9.75 Supersonic Pull-up	242	10.37×10^6	6.01×10^6	140,400
100	11 Subsonic Pull-up	145	11.70×10^6	6.25×10^6	172,500

* CASE 130 IS CRITICAL STATIC DESIGN CONDITION

TABLE 14. SUMMARY OF WING COMPONENT (WCC-1) FAILURE LOADS.

TEST SERIES	TEST CONDITION	FAILURE LOAD % DUL	FAILURE MODE
2	RTA STATIC	122	SUBSTRUCTURE
1	250°F/WET STATIC	126	UPPER SKIN
4	TWO LIFETIME RTA FATIGUE + RTA RSS	118	SUBSTRUCTURE
6	TWO LIFETIME ACCELERATED ENVIRONMENTAL FATIGUE + 250°F/WET RSS	124	UPPER SKIN

accounted for in the reliability evaluation. The overall mean SRV ($\alpha_{SRV} = 17.0$) is used in determining the reliability. The numerical procedure is illustrated below for the RTA data.

Mean Failure Load	$\bar{x} = 1.22$ DUL
Sample Size	$n = 1$
Strength Shape Parameter	$\alpha_S = 20.0$
SRV Shape Parameter	$\alpha_{SRV} = 17.0$

Scale Parameter

$$\hat{\beta} = \bar{x} / \Gamma(1 + \frac{1}{\alpha_S}) = 1.22 / 0.9735 = 1.253$$

$$\begin{aligned} 95\% \text{ Confidence Scale Parameter } \hat{\beta} &= \hat{\beta} / [\chi_{0.95}^2 (2n) / 2n]^{1/\alpha_S} \\ &= 1.253 / (5.991/2)^{0.05} \\ &= 1.186 \end{aligned}$$

The reliability at any load level is then evaluated by numerical integration of Equation (26). The probability function $p(\sigma)$ is assumed to be a two-parameter Weibull distribution with a shape parameter of 17.0.

The reliability at the 250°F/wet environment is evaluated by two different methods. The first method is a direct assessment from the ETW test data and the second method uses the RTA test data and an environmental knockdown factor (k) determined from design allowable data. For the direct method, the average failure of 1.26DUL is used in the evaluation. An environmental knockdown factor of $k = 1.30$ is used in the indirect method.

The 95% static strength distributions are presented in Figure 89. Static strength reliabilities and allowable operating loads are given in Table 15. The RTA static strength reliability of 0.94 is better than B-basis at DUL and higher than A-Basis at DLL. ETW static strength reliability is similar to RTA reliability at DUL and DLL when calculated directly from the ETW test data. Table 15 shows that ETW static strength reliability calculated indirectly from the RTA test data are lower than those

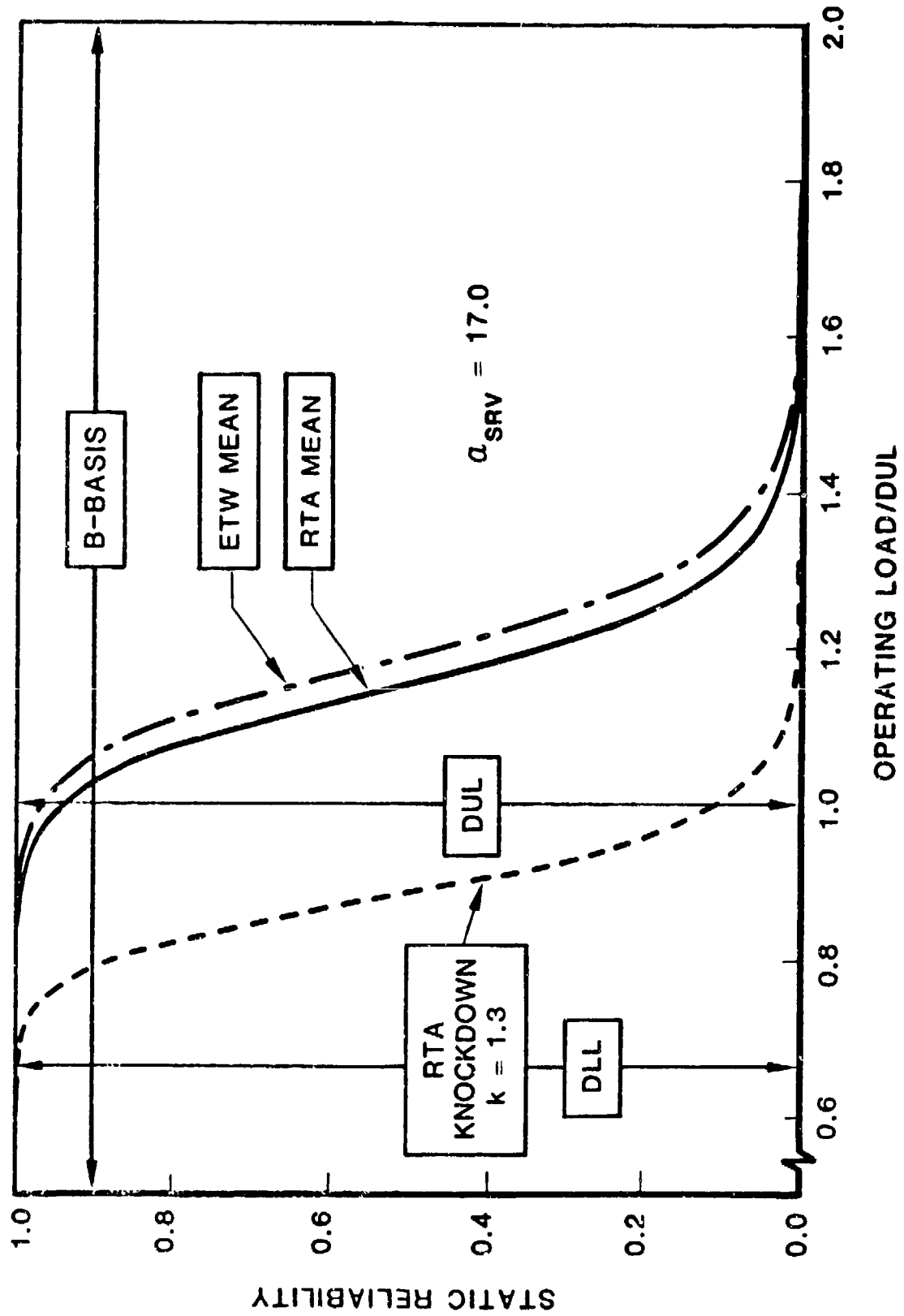

FIGURE 89. WCC-1 STATIC STRENGTH RELIABILITY DISTRIBUTIONS.

TABLE 15. SUMMARY OF WCC-1 STATIC STRENGTH RELIABILITY AND ALLOWABLE OPERATING LOADS.

CONDITION	RELIABILITY		ALLOWABLE (% DUL)	
	DLL	DUL	B-BASIS	A-BASIS
RTA	1.000	0.938	103	91
ETW (MEAN DATA)	1.000	0.966	106	94
ETW (RTA KNOCKDOWN) (k = 1.30)	0.996	0.107	79	70

calculated directly from ETW data. This indicates that the environmental knockdown factor approach produces a conservative estimate of the wing component ETW static strength reliability. This occurs because RTA and ETW static strengths of the wing component are similar. This was caused by a change in failure mode at ETW test conditions, which was attributed to a difference in the most critical static design case for the two test environments.

Table 15 shows that the A-basis RTA and ETW allowable operating loads are 91% DUL and 94% DUL, respectively. This compares with a maximum service load of 87% DUL. It can be concluded, therefore, that the static component tests verified the component design to a high level of confidence for the required in-service loading.

4.2.2 WCC-1 Fatigue Test Data Evaluation

Table 16 summarizes the WCC-1 fatigue test loads. Test enhancement load factor for both RTA and ETW tests was 1.025.

Three methods are used for the fatigue data evaluation. These methods are the load enhancement factor approach, the ultimate strength approach and the residual strength approach. The theoretical background of these approaches was discussed in Section 2. The numerical procedure for the three methods are given below.

4.2.2.1 Load Enhancement Factor Approach

The load enhancement factor approach was discussed in Section 2.2. The one lifetime fatigue reliability, without SRV, is obtained from Equations (16), (17) and (18), and is given by:

$$l = \text{EXP} \left\{ - \frac{\chi^2(2n)/2n}{P_L^{\alpha_R}} \left[\frac{\Gamma(1 + \frac{1}{\alpha_L})}{N} \right]^{\alpha_L} \right\} \quad (31)$$

With SRV, Equation (31) together with the SRV distribution function are used in Equation (26). Results are obtained by carrying out the numerical integration of Equation (26).

TABLE 16. SUMMARY OF WCC-1 FATIGUE TEST LOADS.

TEST	MAXIMUM SPECTRUM LOAD		
	P _{TEST} P _{MSL} LBS	P _{DES} P _{MSL} LBS	P _{TEST} /P _{DES} P _{MSL}
RTA (TS4)	115,100	118,000	1.025
ETW (TS6)	115,100	118,000	1.025

MAXIMUM SPECTRUM LOAD = 82% DUL

The values of various parameters use in the WCC-1 fatigue evaluation are given below:

$$\begin{aligned} \alpha_L &= 1.25 & \Gamma(1 + 1/\alpha_L) &= 0.93138 \\ \alpha_R &= 20.0 & \Gamma(1 + 1/\alpha_R) &= 0.97350 \\ \alpha_{SRV} &= 17.0 & \Gamma(1 + 1/\alpha_{SRV}) &= 0.96930 \end{aligned}$$

$N = 2.0$ LIFETIME

$P_L = 1.025$

$$n = 1 \quad \chi^2_{0.95}(2n)/2n = 2.9955$$

The one lifetime fatigue reliability is plotted against the load enhancement factor (P_L) and is shown in Figure 90. At $P_L = 1.025$ the 95% confidence reliability at one lifetime is 0.493. The ETW fatigue reliability, obtained from indirect method using $k = 1.30$, is 0.091. The relatively low reliability is because of the low load factor used in the test. As shown in Figure 90, a minimum load factor of 1.18 is required in order to achieve the B-basis reliability. The required load factor for the A-basis reliability is 1.39. The reliability provided by the test data and the required A- and B-basis factors are summarized in Tables 17 and 18. Table 17 summarizes the RTA fatigue reliability and Table 18 shows the ETW reliability. The ETW fatigue reliabilities are calculated from both the direct method and the indirect method using environmental knockdown factor.

4.2.2.2 Ultimate Strength Approach

The fatigue reliability determined by the ultimate strength approach is given by

$$R = \text{EXP} \left\{ - \left[\frac{x}{F} \Gamma \left(1 + \frac{1}{\alpha} \right) \right]^\alpha \frac{\chi^2(2n)}{2n} \right\} \quad (32)$$

where F is the static failure load

α is the static strength scatter parameter

x is the constant determined from the threshold stress

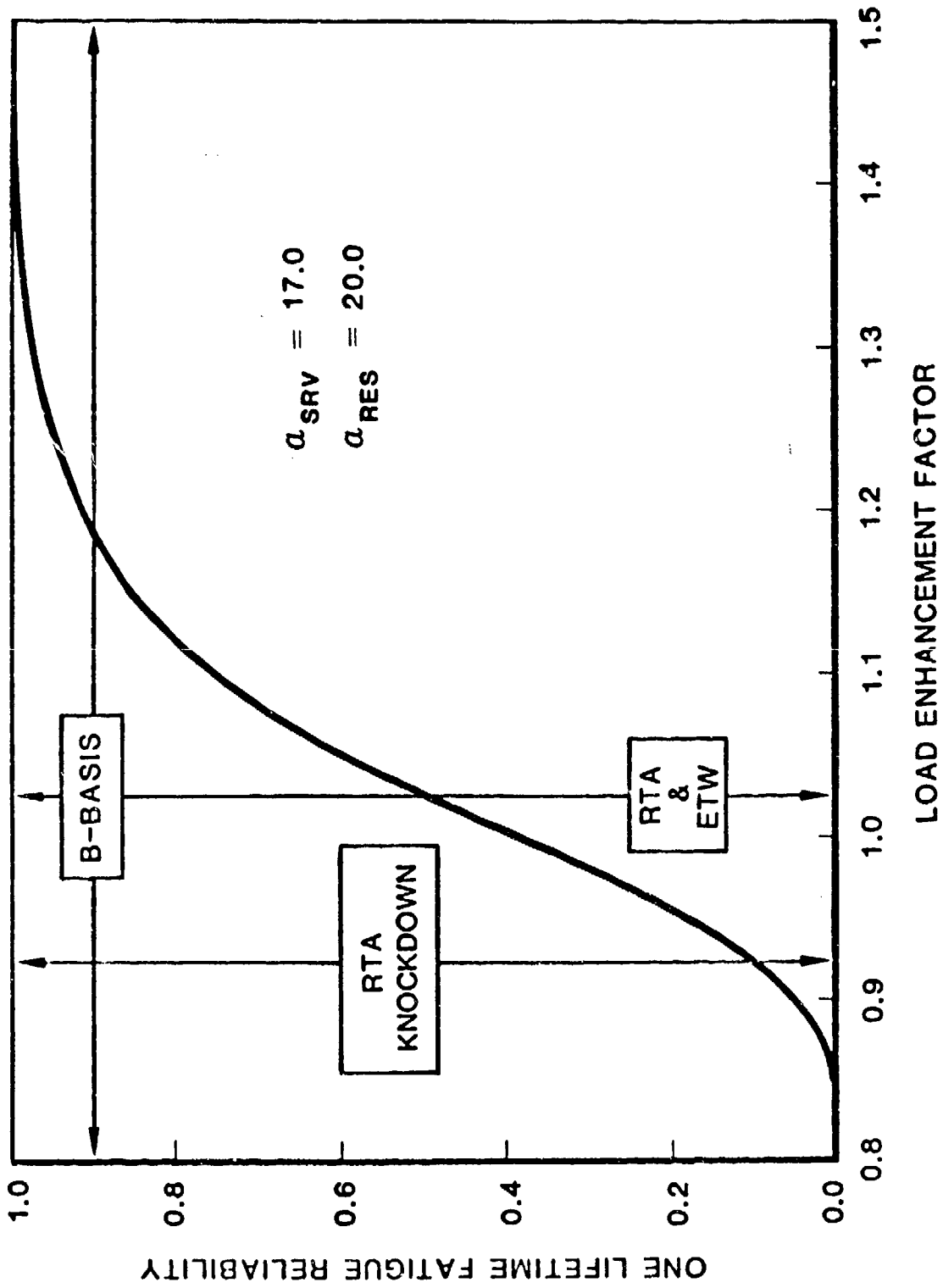

FIGURE 90. WCC-1 FATIGUE RELIABILITY DISTRIBUTION DETERMINED BY THE LOAD ENHANCEMENT FACTOR APPROACH.

TABLE 17. SUMMARY OF WCC-1 RTA ONE LIFETIME FATIGUE RELIABILITY.

APPROACH	ONE LIFETIME FATIGUE RELIABILITY	REQUIRED FACTOR	
		B-BASIS	A-BASIS
LOAD ENHANCEMENT FACTOR	0.493	1.18 P _{MSL}	1.39 P _{MSL}
ULTIMATE STRENGTH	0.380	1.45 DUL	1.70 DUL
RESIDUAL STRENGTH	0.693	1.21 DUL	1.22 DUL

TABLE 18. SUMMARY OF WCC-1 ENVIRONMENTAL ONE LIFETIME FATIGUE RELIABILITY.

APPROACH	DATA BASE	ONE LIFETIME FATIGUE RELIABILITY	REQUIRED FACTOR	
			B-BASIS	A-BASIS
LOAD ENHANCEMENT FACTOR	ETW RTA	0.493	1.18 P _{MSL}	1.39 P _{MSL}
		0.091	1.31 P _{MSL}	1.54 P _{MSL}
ULTIMATE STRENGTH	ETW RTA	0.521	1.45 DUL	1.70 DUL
		0.041	1.61 DUL	1.88 DUL
RESIDUAL STRENGTH	ETW RTA	0.823	1.25 DUL	1.26 DUL
		0.482	1.34 DUL	1.35 DUL

The value of x is determined by solving equation (32) for $F = F_1$ and $R = 0.9$, where

$$F_1 = \frac{P_{MSL}}{P_{DUL}} \cdot \frac{\sigma_S^M}{\sigma_{TH}^M} \cdot \frac{\sigma_{TH}^M}{\sigma_{TH}^B} \quad (33)$$

The definitions and values of σ_S^M/σ_{TH}^M and $\sigma_{TH}^M/\sigma_{TH}^B$ were given in Section 2. In the present data evaluation, the modal values, $\sigma_{TH}^M/\sigma_S^M = 0.71$ and $\sigma_{TH}^B/\sigma_{TH}^M = 0.895$ are used.

The results of WCC-1 component fatigue reliability evaluation are summarized in Tables 17 and 18. The one lifetime fatigue reliability is plotted against static strength and shown in Figure 91. Based on the RTD static test failure load of .22 DUL, the one lifetime fatigue reliability is 0.380. The required static failure load is 1.45 DUL in order to achieve the B-basis fatigue reliability at one lifetime.

4.2.2.3 Residual Strength Approach

The residual strength approach is an application of the Sendecky's fitting model (Reference 14). The original model proposed by Sendecky required static strength, fatigue life and residual strength data. However, the available data only includes static and residual strength data, the fatigue reliability can only be approximately evaluated. In the Sendecky mode, the wear-out equation is given by

$$\sigma_e = \sigma_a \left[(\sigma_r / \sigma_a)^{1/S} + NC \right]^S \quad (34)$$

where, σ_e is the equivalent static strength

σ_a is the maximum applied stress

σ_r is the residual strength

N is the test duration

S and C are fitting constants.

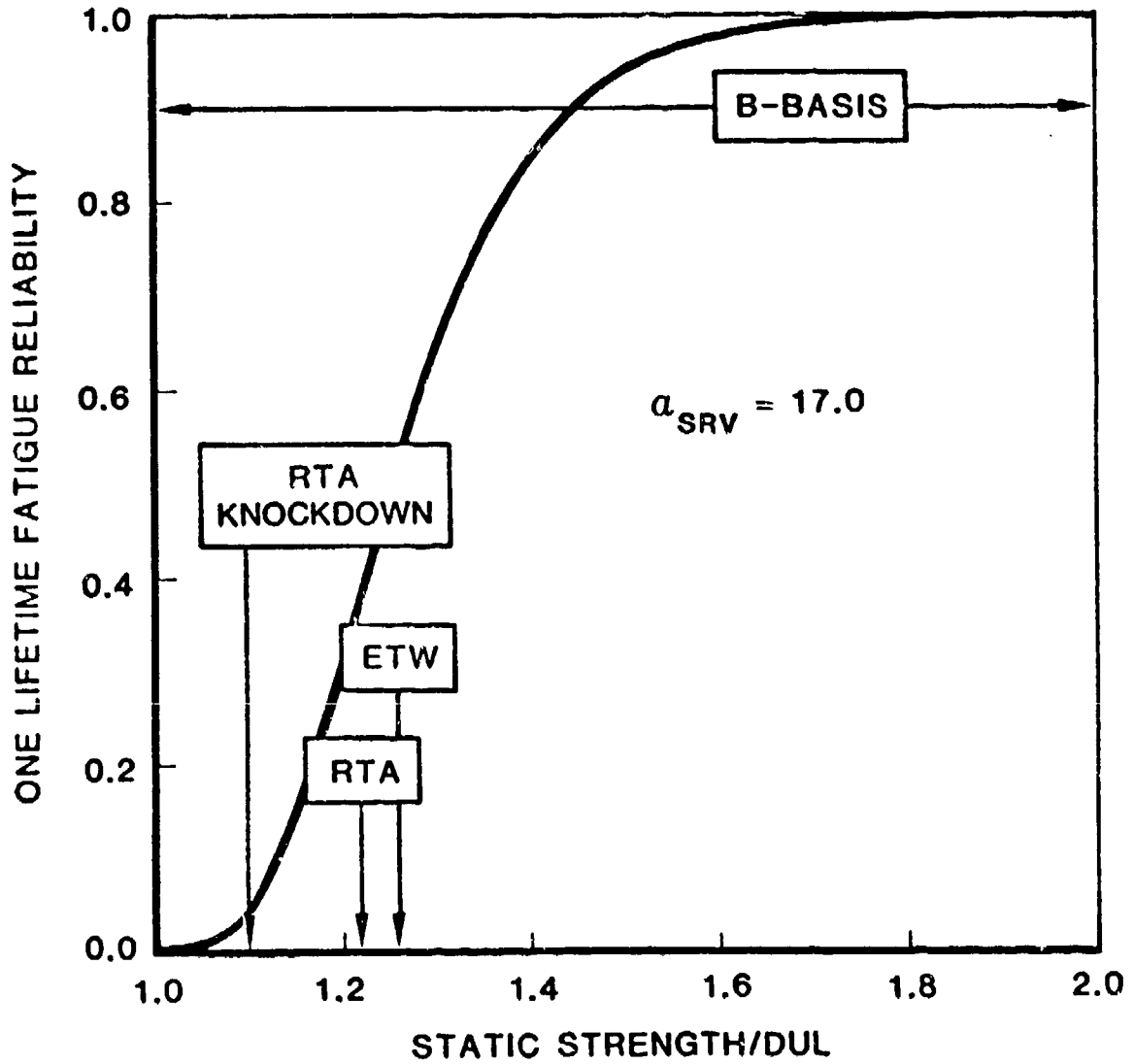

FIGURE 91. WCC-1 FATIGUE RELIABILITY DISTRIBUTION DETERMINED BY THE ULTIMATE STRENGTH APPROACH.

As was discussed in Volume I, it can be shown that the fatigue life can be approximately described by a two-parameter Weibull distribution, with shape parameter α_L . Let α_e be the shape parameter of the equivalent strength distribution. Theoretically, α_e should be equal to the static strength scatter parameter α_s . The relation of α_L and α_e can be approximately given by

$$\alpha_L = S\alpha_e = S\alpha_s \quad (35)$$

Using the modal values of $\alpha_L = 1.25$ and $\alpha_s = 20.0$, the value of S is then 0.0625. From the static and residual strength data, the value of the other fitting constant C can be obtained by solving equation (34). The fatigue life reliability is then computed by first estimating the fatigue life and then substituting it into the Weibull distribution. The following example outlines the numerical procedure

Static strength	$\sigma_n = 1.31$ DUL
Residual strength	$\sigma_r = 1.25$ DUL
Test duration	$N = 2.0$
Applied stress	$\sigma_a = 1.075 \times 0.87 = 0.934$ DUL

From equation (34)

$$1.31 = 0.934 \left[\left(\frac{1.25}{0.934} \right)^{1/0.0625} + 2C \right]^{0.0625}$$

Estimate mean fatigue life at $\sigma_a = 0.87$ DUL

$$\left(\frac{\sigma_u}{\sigma_a} \right)^{1/S} = \left(\frac{\sigma_r}{\sigma_a} \right)^{1/S} + NC$$

At fatigue failure, $N = \bar{N}_F$, $\sigma_r = \sigma_a$, then

$$\bar{N}_F = \frac{\left(\frac{1.31}{0.87} \right)^{1/0.0625} - 1}{59.176} = 11.78 \text{ LT}$$

$$\hat{\beta} = N_F / \Gamma(1 + \frac{1}{\alpha_L}) = 11.78 / 0.93138 = 12.65 \text{ LT}$$

$$\hat{\beta}^V = \hat{\beta} / [\chi(2n)/2n]^{1/\alpha_L} = 12.65 / (2.995)^{1/1.25} = 5.26 \text{ LT}$$

The 95% confidence reliability at one lifetime under the maximum spectrum load is

$$R = \text{EXP} [-(1.0/5.26)^{1.25}] = 0.882$$

The reliability including SRV effects is computed by numerical integration of an expression similar to equation (26).

The results of fatigue reliability evaluation are summarized in Tables 17 and 18. The one lifetime fatigue reliability is shown as a function of the residual strength in Figure 92. The RTA one lifetime fatigue reliability obtained from the test data is 0.693 and the required residual strength for the B-basis fatigue reliability is 1.21 DUL.

4.3 Wing Specimens Test Data Evaluation Summary

All the wing specimens test data are evaluated for static and fatigue reliability in the same manner as for the WCC-1 component. This section summarizes the results of these evaluations.

Table 19 summarizes the static strength reliabilities and maximum allowable operating loads for all the wing test specimens.

Table 19 shows that under RTA conditions, average test failure loads ranged from 122% DUL to 244% DUL. Static strength reliabilities calculated at RTA conditions exceed A-basis at DLL for all the test specimens. In addition, B-basis allowable operating loads exceed DUL and A-basis allowable operating loads exceed 90% DUL for all test specimens. Thus, it can be concluded that very high RTA static reliability has been demonstrated for the composite wing structure.

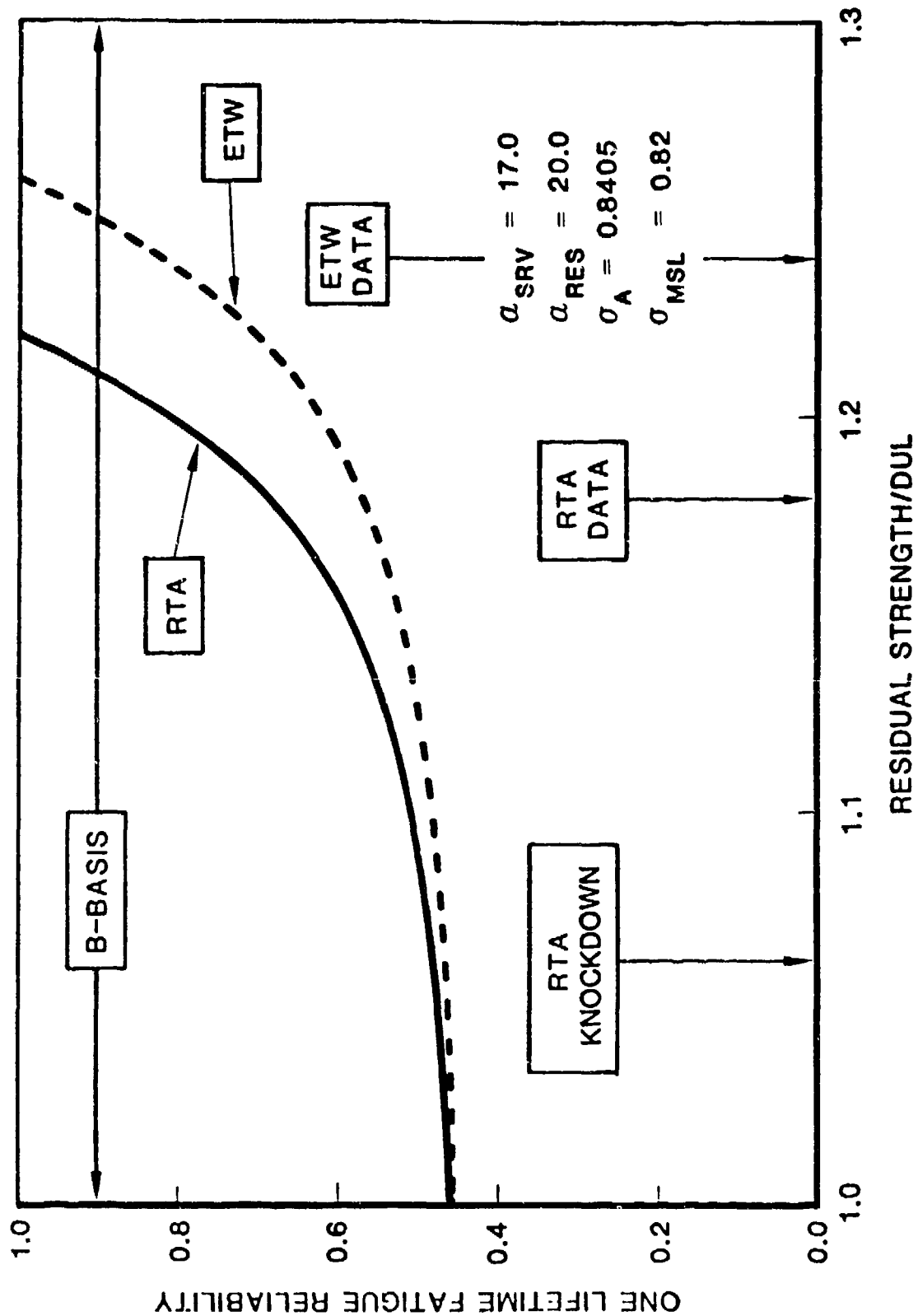

FIGURE 92. WCC-1 FATIGUE RELIABILITY DISTRIBUTION DETERMINED BY THE RESIDUAL STRENGTH APPROACH.

TABLE 19. SUMMARY OF STATIC STRENGTH RELIABILITIES AND ALLOWABLE OPERATING LOADS FOR WING TEST SPECIMENS.

SPECIMEN I.D.	FAILURE LOAD %DUL		STATIC RELIABILITY						ALLOWABLE OPERATING LOAD (%DUL)			
	RTA	ETW	RTA			ETW*			RTA		ETW*	
			DLL	DUL	DLL	DUL	DLL	DUL	B-BASIS	A-BASIS	B-BASIS	A-BASIS
WE-1	244	76	1.000	1.000	0.863	0.005	209	185	66	58		
WE-2	173	123	1.000	1.000	1.000	0.961	149	132	105	93		
WEC-1	186	160	1.000	1.000	1.000	1.000	159	141	137	122		
WEC-2	197	130	1.000	1.000	1.000	0.981	166	147	109	97		
WEC-3	128	129	1.000	0.975	1.000	0.978	108	95	109	96		
WS-1	131	102	1.000	0.985	0.999	0.362	111	98	85	75		
WS-2	197	180	1.000	1.000	1.000	1.000	164	145	150	133		
WCC-1	122	126	1.000	0.938	1.000	0.976	103	91	106	94		

* 250°F/WET CONDITIONS

Table 19 shows that under 250°F/wet test conditions all test specimens except WE-1, had average failure loads that exceed DUL. Failure loads were in the range of 102% DUL to 180% DUL. Average failure load for specimen WE-1 was 76% DUL. 250°F/wet static strength reliabilities for WE-1 are 0.863 at DLL and 0.005 at DUL. These low reliabilities are simply a reflection of the low average failure load (76% DUL) of specimen WE-1. However, it should be noted that the temperature associated with the WE-1 critical static design case is 192°. Therefore, the reliabilities calculated from the 250°F/wet test data are conservative. The static strength reliability at 192°F was recalculated from the 250°F/wet test data using the environmental knock-down factor (k). The resultant reliabilities at DLL and DUL increased to 1.000 and 0.498, respectively. For the remaining wing test specimens, the 250°F/wet static strength reliability exceeded A-basis at DLL. The static strength reliabilities at DUL exceeded B-basis for all remaining specimens except WS-1 (0.362). The low 250°F/wet static strength reliability calculated for WS-1 can be attributed to the mixed failure modes observed in the 250°F/wet static tests. Average failure load for all tests was 116% DUL, however, two failure modes were observed, these were, upper skin failure and intermediate spar/lower skin cocured joint failure. The average failure load for upper skin failure was 123% DUL, while the average failure load for intermediate spar/lower skin failure was 102% DUL. Since mixed failure modes were observed, the static strength reliability was calculated using the failure load which gave the lowest static strength. Thus, an average failure load of 102% DUL was used for the reliability calculations. This resulted in a low static strength reliability at DUL. However, it should be noted that Table 19 does show that the A-basis allowable operating load exceeds DLL.

Table 20 summarizes the one lifetime fatigue reliabilities for all wing test specimens. The fatigue reliabilities calculated using the load enhancement approach assume that fatigue failures occurred after two lifetimes. However, the major-

TABLE 20. SUMMARY OF ONE LIFETIME FATIGUE RELIABILITIES FOR WING TEST SPECIMENS.

SPECIMEN I.D.	FATIGUE TEST LOAD ENHANCEMENT FACTOR			FATIGUE RELIABILITY AT 1 LT								
	RTA	ETW	ETW	RTA			ETW			RSS		
				LEF	US	RSS	LEF	US	RSS	LEF	US	RSS
WE-1	1.87	0.58	1.000	1.000	1.000	1.000	0.000	0.000	0.000	0.000	0.000	0.000
WE-2	1.55	1.10	0.999	0.898	1.000	1.000	0.797	0.001	0.001	0.976		
WEC-1	1.53	1.32	0.998	0.996	1.000	1.000	0.971	0.957	0.983			
WEC-2	1.66	1.10	0.998	0.995	1.000	1.000	0.764	0.532	0.814			
WEC-3	0.94	0.94	0.245	0.060	1.000	1.000	0.282	0.069	0.484			
WS-1	1.08	0.96	0.827	0.775	0.868	0.132	0.055	0.775				
WS-2	--	1.00	--	0.462	--	0.400	0.969	0.462				
WCC-1	1.03	1.03	0.493	0.380	0.693	0.493	0.521	0.832				

LEF = LOAD ENHANCEMENT FACTOR APPROACH

US = ULTIMATE STRENGTH APPROACH

RSS = RESIDUAL STRENGTH APPROACH

ity of the wing specimen fatigue tests were run-outs at two fatigue lifetimes, which were subsequently residual static strength tested. Thus, the fatigue reliabilities calculated by the load enhancement approach are conservative. Fatigue reliabilities calculated using the ultimate strength approach are estimates based on static failure loads. The fatigue reliabilities calculated using the residual strength approach provide the best estimates of one lifetime fatigue reliabilities because it accounts for the specimen residual strength after two lifetimes of fatigue loading.

The fatigue reliabilities calculated using the residual strength approach, which are presented in Table 20, show significant scatter. The reason for this scatter in calculated fatigue reliability is the variation in test load enhancement factors used in fatigue tests. For RTA tests, test load enhancement factors ranged from 0.94 to 1.87 and for environmental tests, test load enhancement factors ranged from 0.58 to 1.32. These variations in test load enhancement factors were caused by variations in static test failure load as a function of DUL for each of the test specimens. Because of the higher scatter in composite fatigue test data, it is necessary to increase test load severity in order to demonstrate adequate fatigue reliability in a two lifetime fatigue test.

The following conclusions can be drawn from the results of the wing test data evaluation.

- (1) A high degree of static strength reliability has been demonstrated by the wing test data.
- (2) One lifetime fatigue reliabilities demonstrated by the wing test data were inadequate because insufficient test load severity was used for the two lifetime fatigue tests.

4.4 Fuselage Component FCC-1 Data Evaluation

The FCC-1 fuselage component is shown in Figure 93 and the loading of the component is shown in Figure 94. The criti-

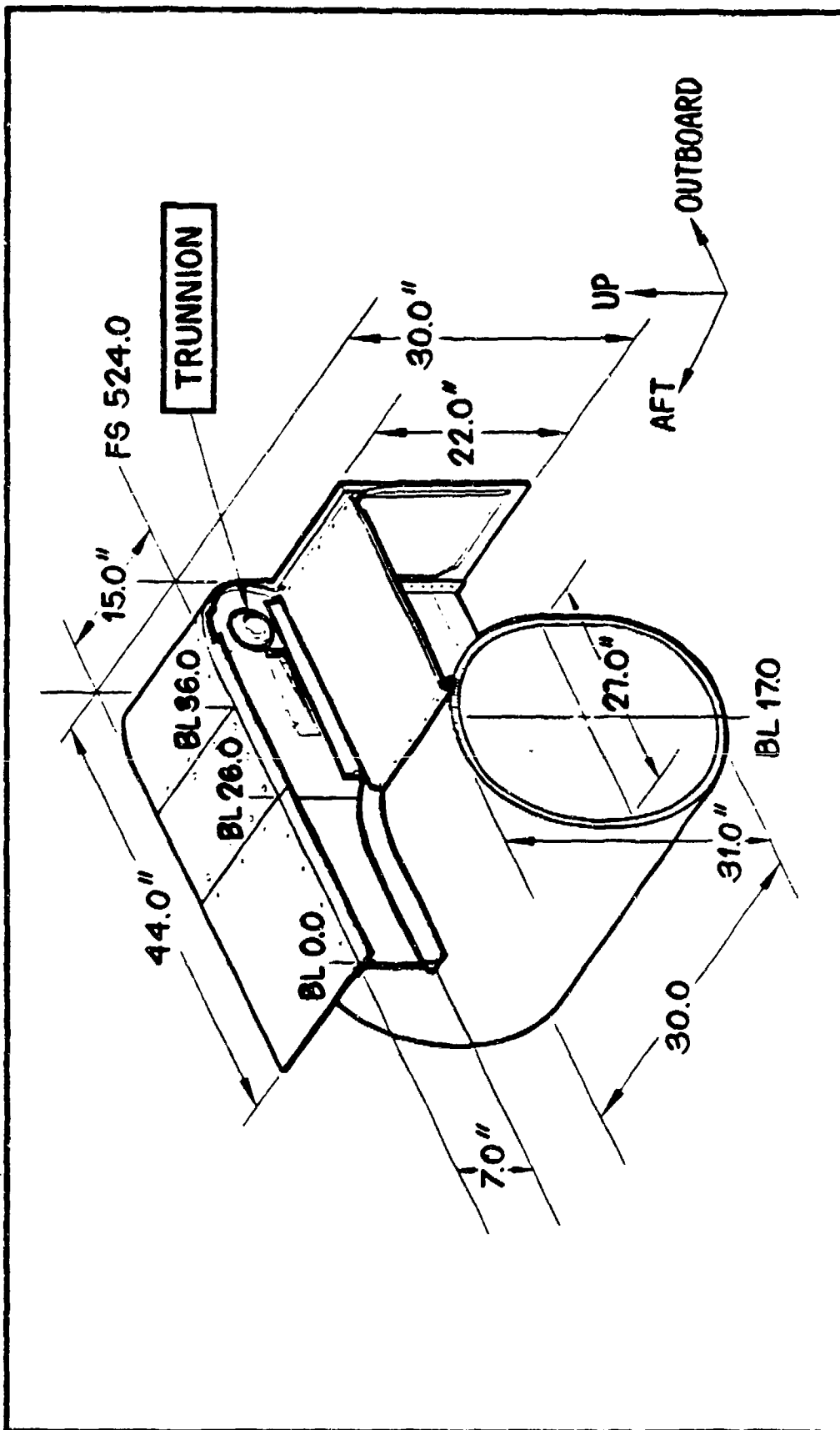

FIGURE 93. FUSELAGE COMPONENT (FCC-1).

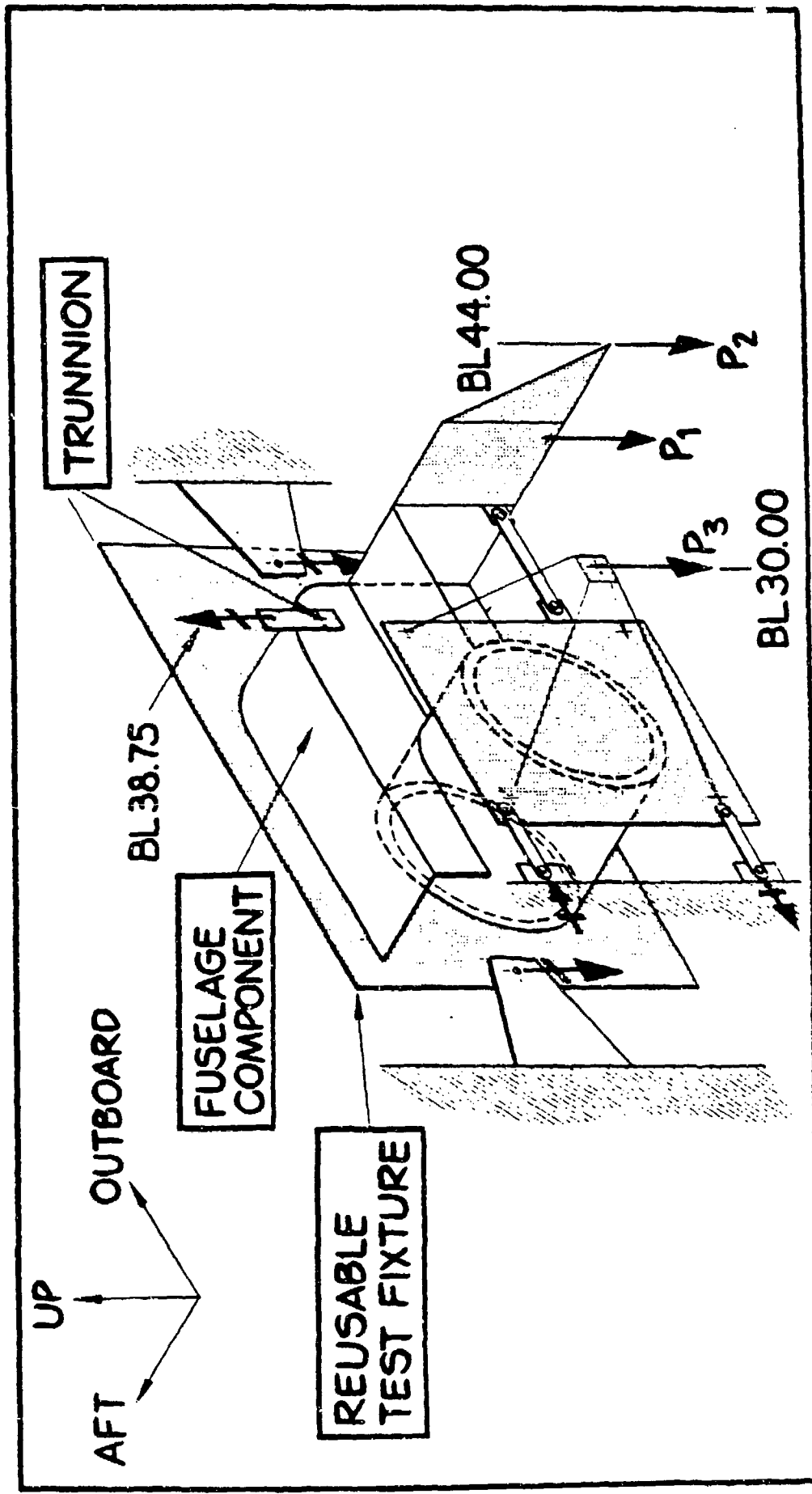

FIGURE 94. FCC-1 LOADING.

cal static design conditions is given in Table 21. A total of two static and one fatigue components were tested. The results are presented in Table 22.

4.4.1 FCC-1 Static Test Data Evaluation

The 95% confidence static strength reliability distributions are presented in Figure 95. Static strength reliabilities and allowable operating loads are summarized in Table 23. As can be expected, the RTA static strength reliability at DUL is very low (0.340), because of the low RTA static failure load (102% DUL). As a result, the static strength reliability at the design environment (242°F/wet) determined from knockdown of RTA data is also low. This reliability is 0.882 at DLL and 0.006 at DUL (Table 23). The reliability determined from the RTA test result is over-conservative. This is because the failure load of 102% DUL does not represent the total structure strength. The test failure was fixture failure as indicated in Table 22. The static strength determined from the 250°F/wet test data exceeded A-basis as shown in Table 23.

4.4.2 FCC-1 Fatigue Test Data Evaluation

FCC-1 fatigue test loads is summarized in Table 24. The test load enhancement factor was 1.34. Only a RTA fatigue test was conducted.

Table 25 shows the one lifetime RTA fatigue reliability determined from the three analytical approaches. The low fatigue reliability (0.001) obtained from the ultimate strength approach, reflects the low RTA static failure load. This value is not accurate because of the test fixture failure during test. The load enhancement factor approach gives a reliability of 0.983 and the residual strength approach gives a fatigue reliability of 1.000. The reliability distributions are shown in Figures 96 and 97.

The environmental fatigue reliability is shown in Table 26. Because only RTA fatigue test was conducted, the fatigue reliability is evaluated based only on RTA test data. At

TABLE 21. SUMMARY OF FUSELAGE COMPONENT (FEC-1) STATIC ULTIMATE DESIGN LOADS.

CONDITION NUMBER	LOAD FACTOR N_z	TEMPERATURE °F	P_1 LBS	P_2 LBS	P_3 LBS	TRUNNION LOAD LBS
120 *	9.75	242	3410	-16370	-6480	76800

* CASE 120 IS CRITICAL STATIC DESIGN CONDITION

TABLE 22. SUMMARY OF FCC-1 FAILURE LOADS.

TEST SERIES	TEST CONDITION	FAILURE LOAD % DUL	FAILURE MODE
2	RTA STATIC	102	TEST FIXTURE FAILURE
1	250°F/WET STATIC	145	FUSELAGE SIDE PANEL
4	TWO LIFETIME RTA FATIGUE + RTA RSS	145	"

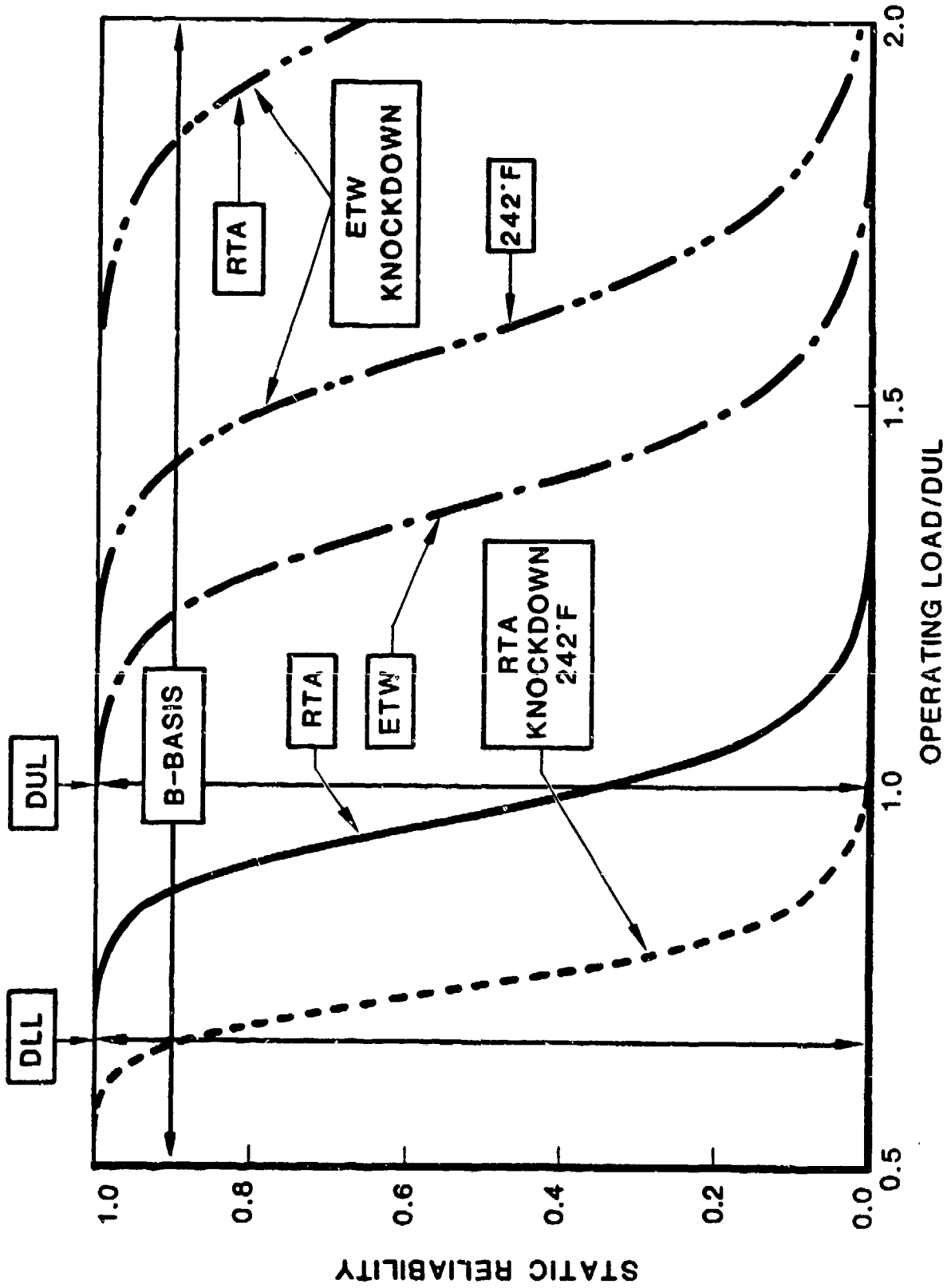

FIGURE 95. FCC-1 STATIC STRENGTH RELIABILITY DISTRIBUTIONS.

TABLE 23. SUMMARY OF FCC-1 STATIC RELIABILITY.

CONDITION	RELIABILITY		ALLOWABLE % DUL	
	DLL	DUL	B-BASIS	A-BASIS
RTA	0.999	0.340	86	76
ETW 250°F - DATA 242°F - KNOCKDOWN RT - KNOCKDOWN	1.000	0.998	122	108
	1.000	1.000	142	126
	1.000	1.000	184	163
ETW RTA KNOCKDOWN 242°F	0.882	0.006	66	59

TABLE 24. SUMMARY OF FCC-1 FATIGUE LOADS.

TEST	MAXIMUM SPECTRUM LOAD		
	P_{MSL}^{TEST} LBS	P_{MSL}^{DES} LBS	$P_{MSL}^{TEST} / P_{MSL}^{DES}$
RTA (TS4)	84400	63000	1.34

MAXIMUM SPECTRUM LOAD = 82% DUL

TABLE 25. SUMMARY OF FCC-1 RTA FATIGUE RELIABILITY AT ONE LIFETIME.

APPROACH	ONE LIFETIME FATIGUE RELIABILITY	REQUIRED FACTOR	
		B-BASIS	A-BASIS
LOAD ENHANCEMENT FACTOR	0.983	1.18 P _{MSL}	1.39 P _{MSL}
ULTIMATE STRENGTH	0.001	1.47 DUL	1.70 DUL
RESIDUAL STRENGTH	1.000	0.82 DUL	0.82 DUL

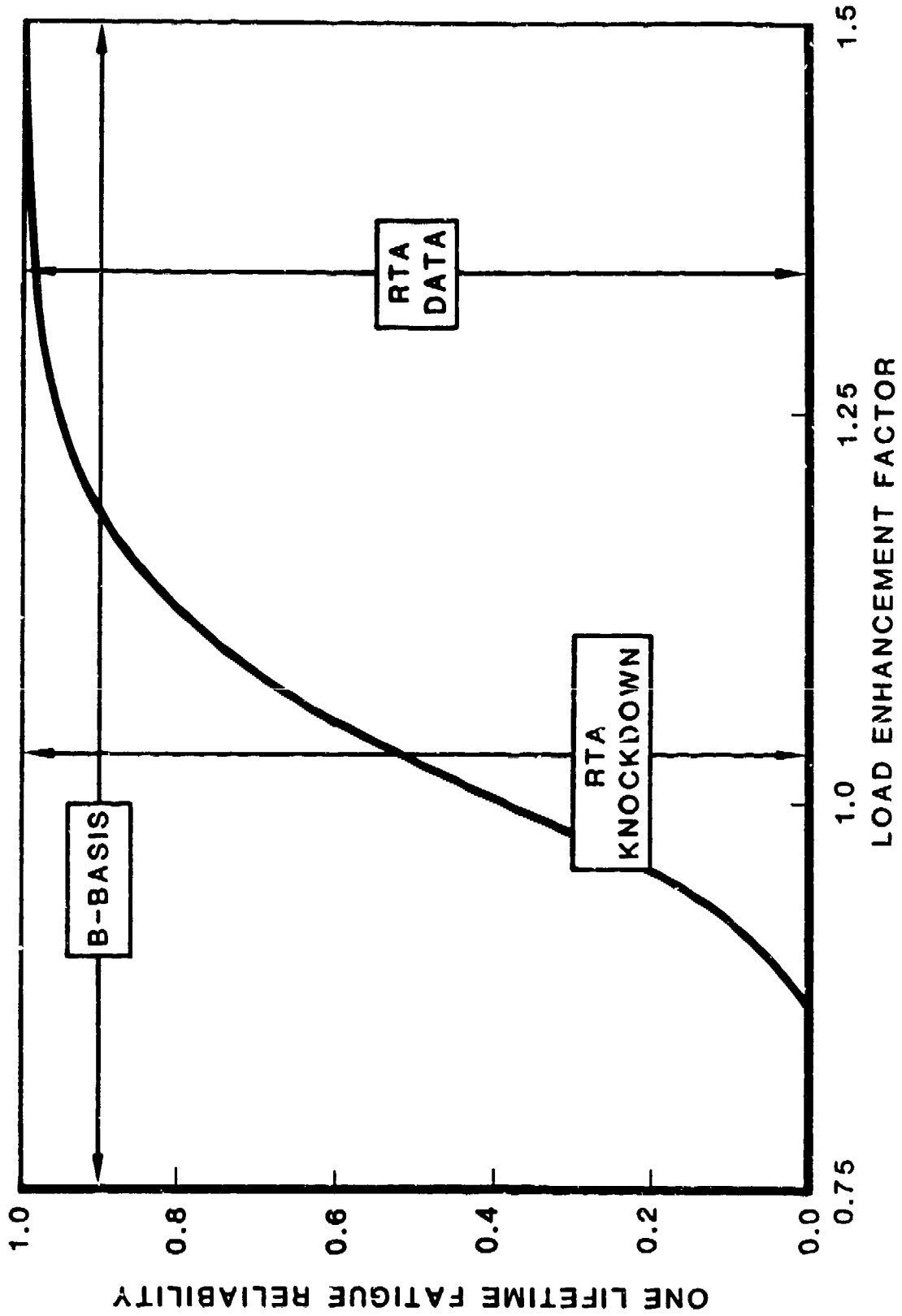

FIGURE 86. FCC-1 FATIGUE RELIABILITY - LOAD ENHANCEMENT FACTOR APPROACH.

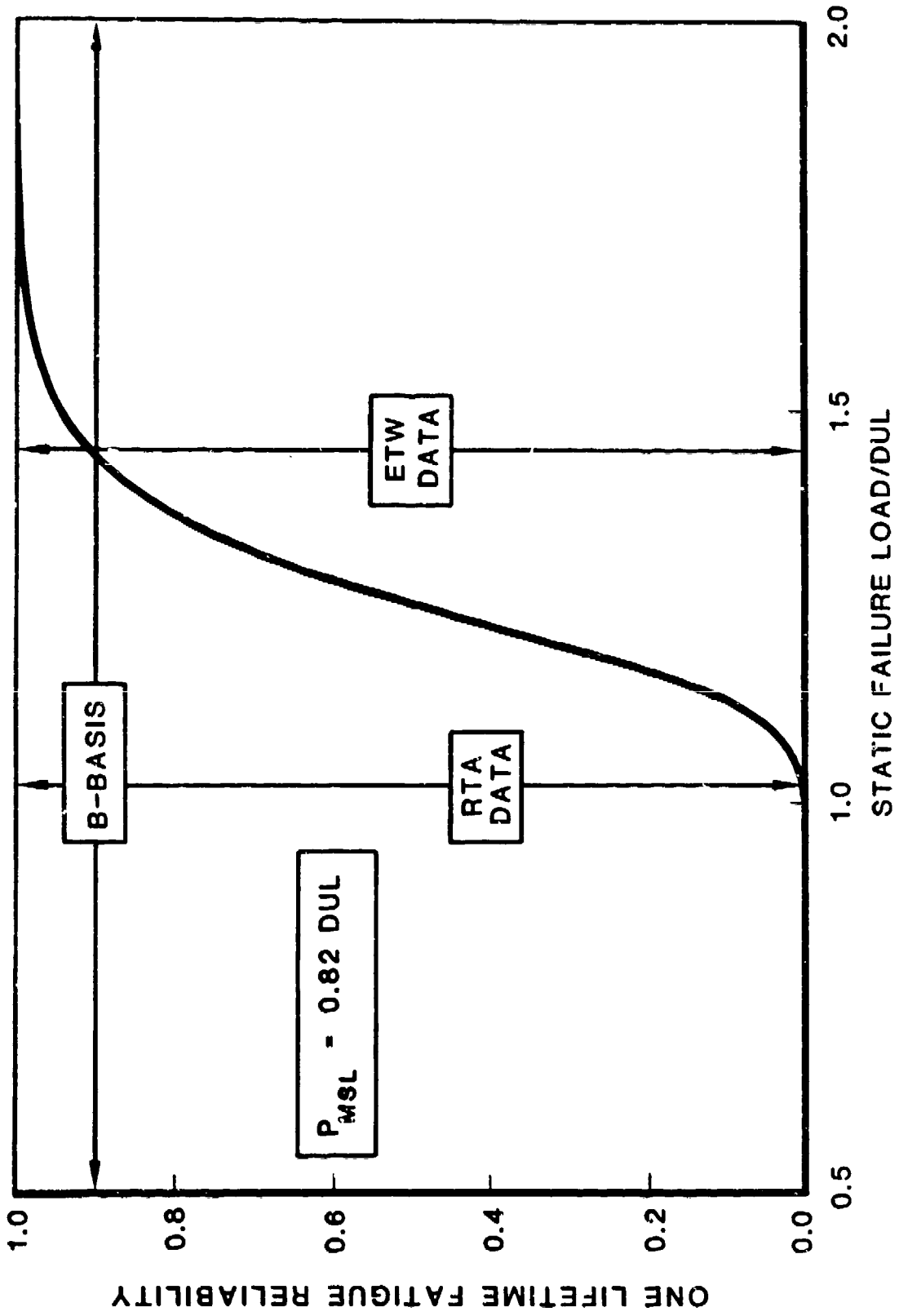

FIGURE 97. FCC-1 FATIGUE RELIABILITY - ULTIMATE STRENGTH APPROACH.

TABLE 26. SUMMARY OF FCC-1 ENVIRONMENTAL FATIGUE RELIABILITY AT ONE LIFETIME.

APPROACH	DATA BASE	ONE LIFETIME FATIGUE RELIABILITY	REQUIRED FACTOR	
			B-BASIS	A-BASIS
LOAD ENHANCEMENT FACTOR	RTA	0.516	1.31 P _{MSL}	1.54 P _{MSL}
ULTIMATE STRENGTH	ETW	0.903 AT 250°F	1.45 DUL	1.70 DUL
	ETW	0.989 AT 242°F	1.25 DUL	1.46 DUL
	ETW	1.000 AT RT	0.96 DUL	1.12 DUL
	RTA	0.000 AT 242°F	1.88 DUL	2.21 DUL
RESIDUAL STRENGTH	RTA	1.000 AT 242°F	1.07 DUL	1.07 DUL

242°F/wet condition, the one lifetime fatigue reliability is 0.516, 0.000 and 1.000 from the load factor, ultimate strength and residual strength, respectively, based on RTA data. Based on the ETW static test data, the fatigue reliability at 242° is 0.989 as determined from the ultimate strength approach.

4.5 Fuselage Specimen Test Data Evaluation Summary

Table 27 summarizes the static strength reliabilities and allowable operating loads for all the fuselage test specimens.

Table 27 shows that the average RTA static failure loads ranged from 102% DUL to 286% DUL. Static strength reliabilities calculated at RTA conditions exceed A-Basis at DLL for all the test specimens, except FEC-4. The low strength reliability of FEC-4 specimen is a reflection of the high data scatter associated with the particular failure mode (stiffener disbond) of this specimen type. The static strength reliability at DUL exceeds B-Basis for specimens FEC-1, FEC-2 and FEC-3. The reliability at DUL for FEC-4 specimens is 0.402. This is also because of the high strength data scatter of the stiffener disbond failure mode observed in these specimens. The reliability of the FCC-1 specimen at DUL is 0.340; this is because of the low failure load (102% DUL) of the specimen. However, as was pointed out earlier, the failure was test fixture failure and thus did not represent the actual strength of the specimen. The RTA static strength reliability at DUL calculated from the 250°F/wet data was 1.000. The B-Basis RTA allowable operating loads for all fuselage specimens exceed DLL. The A-Basis RTA allowable operating loads for all specimens, except FEC-4, also exceed DLL.

Table 27 shows that under 250°F/wet test conditions, all test specimens except FEC-4 had average failure loads exceed DUL. The average failure load ranged from 125% DUL to 359% DUL. The average failure load for specimen FEC-4 was 86% DUL. Except for specimen FEC-4, the 250°F/wet static strength reliabilities at DLL all exceed A-Basis and they all exceed B-Basis at DUL. The 250°F/wet reliability for specimen FEC-4 is 0.703 at DLL and

TABLE 27. SUMMARY OF STATIC STRENGTH RELIABILITIES AND ALLOWABLE OPERATING LOADS FOR FUSELAGE TEST SPECIMENS.

SPECIMEN I.D.	FAILURE LOAD %DUL		STATIC RELIABILITY				ALLOWABLE OPERATING LOAD (%DUL)			
	RTA	ETW	RTA		ETW*		RTA		ETW*	
			DLL	DUL	DLL	DUL	B-BASIS	A-BASIS	B-BASIS	A-BASIS
FE-1	286	216	1.000	1.000	1.000	1.000	245	217	185	164
FEC-2	125	125	1.000	0.972	1.000	0.974	107	95	108	95
FEC-3	281	359	0.995	0.977	0.998	0.987	146	81	170	95
FEC-4	110	86	0.902	0.402	0.703	0.067	67	44	53	35
FCC-1	102	145	0.999	0.340	1.000	0.998	86	76	122	108

* 250°F/WET CONDITIONS

0.067 at DUL. The ETW B-basis allowable exceed DLL for all specimens with the exception of FEC-4. The ETW B-basis allowable for FEC-4 specimens is 53% DUL and A-basis is 35% DUL.

From the results of the static data evaluation, it can be concluded that the composite fuselage structures in Reference 5 demonstrated very high RTA and ETW static reliability for the typical in-plane composite failures. For specimens that exhibited out-of-plane structural failure modes, such as specimens FEC-3 and FEC-4, the static strength scatter is higher and the test data of Reference 5 demonstrated B-basis reliability at DLL under RTA conditions.

Table 28 summarizes the one lifetime fatigue reliabilities for all fuselage test specimens. The fatigue reliabilities calculated using the load enhancement approach assume that fatigue failures occurred after two lifetimes. However, all of the fuselage specimen fatigue tests were run-outs at the two fatigue lifetimes, which were subsequently residual static strength tested. Thus, the fatigue reliabilities calculated by the load enhancement approach are conservative. Fatigue reliabilities calculated using the ultimate strength approach are estimates based on static failure loads. The fatigue reliabilities calculated using the residual strength approach provide the best estimates of one lifetime fatigue reliabilities because it accounts for the specimen residual strength after two lifetimes of fatigue loading.

The fatigue reliabilities calculated using the residual strength approach exceed B-basis for all specimens. As shown in Table 28, the one lifetime fatigue reliability for all specimens, except FEC-4, exceed B-basis using all three approaches. The low fatigue reliability of FEC-4 calculated using load enhancement factor (LEF) approach is a reflection of the low LEF (1.08 at RTA and 0.94 at ETW) used in the test. The low fatigue reliability for FEC-4 calculated using the ultimate strength approach is because of the low average strength and high scatter. The low fatigue reliability for FCC-1 calculated using the ultimate

TABLE 28. SUMMARY OF ONE LIFETIME FATIGUE RELIABILITIES FOR FUSELAGE TEST SPECIMENS.

SPECIMEN I.D.	FATIGUE TEST LOAD ENHANCEMENT FACTOR		FATIGUE RELIABILITY AT 1 LT					
	RTA	ETW	RTA			ETW		
			LEF	US	RSS	LEF	US	RSS
FE-1	2.81	2.13	1.000	1.000	1.000	1.000	1.000	1.000
FEC-2	1.50	1.50	0.998	0.994	1.000	0.998	0.994	1.000
FEC-3	2.38	2.38	0.974	0.996	0.993	0.970	0.999	0.979
FEC-4	1.08	0.94	0.578	0.826	0.941	0.319	0.508	1.000
FCC-1	1.34	--	0.983	0.001	1.000	--	0.903	--

LEF = LOAD ENHANCEMENT FACTOR APPROACH

US = ULTIMATE STRENGTH APPROACH

RSS = RESIDUAL STRENGTH APPROACH

strength approach is simply a reflection of the fixture failure of the test.

The following conclusions can be drawn from the fuselage data evaluation:

1. A high degree of static strength reliability has been demonstrated by the fuselage test data with typical composite in-plane failures.
2. Static strength reliability for structures with out-of-plane failures may be inadequate because of the high strength scatter.
3. One lifetime fatigue reliabilities demonstrated by the fuselage test data were adequate.

SECTION 5CERTIFICATION TESTING RECOMMENDATIONS5.1 Testing Requirements

Specific certification testing requirements are detailed in the following paragraphs. The design allowable tests are coupon level tests. The results of these tests are used to establish allowable strengths. Test variables at this level should include loading mode (tension, compression, shear) and environment (temperature, moisture). The design development testing should be planned based on the building block approach. Structural element, element combinations and subcomponents are tested to verify the design concepts. Sufficient number of tests should be conducted to identify different failure modes. The worst case environment should be included in the test plan. Full-scale tests are used to verify the overall reliability of the structure and to identify any unanticipated hot spots. Separate tests should be conducted for static strength and fatigue life.

5.1.1 Design Allowables

The purpose of design allowable tests is to evaluate the material scatter and to establish strength and life parameters for structure design. Because composites are environmental sensitive, design allowables should be obtained for the entire range of the environmental service envelope of an aircraft. Statistical analysis methods must be used to compute the design allowables. Sufficient number of tests are required to sustain the specific level of confidence of the allowables. Key elements of test planning and data analysis are discussed below.

5.1.1.1 Static Design Allowables

Static design allowables include static tension, compression and shear strengths of composite materials. The Weibull distribution is recommended to describe the test data variation. The maximum likelihood estimate (MLE) method discussed in Sec-

tion 2 of Volume I is recommended for computation of the Weibull parameters. The shape and scale parameters (α and β) are estimated by solving equations (5) and (6) and the A- or B-Basis allowables are computed from equation (9) in Volume I. The computer program WEIBULL in the Appendix is written for the computation of design allowables from test data.

From the extensive data analysis, documented in Volume I, the modal value of $\alpha=20.0$ is recommended for determination of the static strength allowables for typical graphite/epoxy composites. Based on this value of α , with 15 data points, the B-basis to mean strength ratio is 0.901 and the A-basis to mean strength ratio is 0.801. For a sample size of 30, the B-basis and A-basis knockdown factors are 0.905 and 0.805, respectively. The influence of sample size on the B-basis static strength was shown in Figure 7. It can be seen from the figure that for typical graphite/epoxy composites, $\alpha=20.0$, the B-basis knockdown factor exceeds 0.85 for any sample size. Therefore, for typical graphite/epoxy composites, a knockdown factor of 0.8 times mean strength (as sometimes used in the industry) is a conservative approach to determination of B-basis allowable. Figure 7 also indicates that for the Weibull shape parameter of $\alpha < 10.0$, the knockdown factor of 0.8 becomes an unconservative estimate of the B-basis allowable.

In planning a design allowable testing, it is important that sufficient number of tests be conducted to generate meaningful statistical parameters. In general, the number of specimens required depends on the scatter of the data. The higher the data scatter, the larger number of specimens are required. Based on the scatter analysis performed in Task I, the number of specimens recommended for B-basis allowables is 15 and for A-basis is 30. This is because within the range of α for typical composites ($\alpha=20 - 30$) the B-basis knockdown factor remains approximately constant for sample size greater than 15. The A-Basis knockdown factor stabilizes for sample sizes larger than 30. The B- and A-basis knockdown factors at these recommended samples sizes for typical α values are provided in Table 29.

TABLE 29. DESIGN ALLOWABLE TO MEAN STRENGTH RATIO FOR THE RECOMMENDED SAMPLE SIZE.

<i>a</i>	B-BASIS n=15	A-BASIS n=30
10.0	0.808	0.645
12.0	0.838	0.695
14.0	0.860	0.733
16.0	0.877	0.762
18.0	0.890	0.786
20.0	0.901	0.805
22.0	0.909	0.821
24.0	0.917	0.835
26.0	0.923	0.847
28.0	0.928	0.857
30.0	0.933	0.866

MODAL *a*

The design allowable tests should be planned to develop the strength to temperature envelope relationship for the full range of the service temperature of aircraft. The moisture level for the test specimens should be either end-of-lifetime level or the maximum level in the design lifetime, whichever is higher. The tests should also provide data for each failure mode. Tension, compression and shear strengths test should be conducted at each environment. The design allowable tests should be conducted at both lamina and laminate levels. The purpose of the lamina test is to establish the mechanical properties such as Young's moduli, shear modulus and Poisson ratio. These tests should include longitudinal and transverse tension and compression and shear tests. At the laminate level, two laminates representing the practical fiber dominated and matrix dominated lay-ups should be selected. The test specimens should include unnotched specimens to determine the laminate design strain. Other tests such as open and filled holes, bearing and bolt bearing by-pass should also be included.

Typical design allowable test matrices are shown in Tables 30 and 31. These tables show that design allowables will be obtained directly from the test data for the key test environments. For the secondary test conditions, the allowables can be computed using the statistical parameters established from the key tests.

The results of the design allowable tests should be analyzed individually for each key test condition. The design allowables are recommended to be generated using the worst scatter parameter (lowest α) among all the tests. This procedure is shown schematically in Figure 98.

An alternate approach for determining design allowables is to use the pooling technique discussed in Section 2 of Volume I. The joint Weibull analysis can be used to pool the test data. The joint Weibull shape parameter is then used to compute the allowables. The computation procedure is automated in the computer program WEIBJNT given in the Appendix. The results obtained from the joint Weibull analysis are less conservative

TABLE 30. LAMINA STATIC STRENGTH ALLOWABLE TEST MATRIX.

TEST CONDITION	TENSION		COMPRESSION		SHEAR
	0°	90°	0°	90°	±45°
LTD	15(30)	15(30)	6	6	6
RTW	15(30)	15(30)	15(30)	15(30)	15(30)
ETW-1	6	6	6	6	6
ETW-2	6	6	6	6	6
ETW-3	6	6	6	15(30)	15(30)

NUMBERS IN () ARE FOR A-BASIS ALLOWABLES.
ETW-3 IS THE WORST CASE ENVIRONMENT.

TABLE 31. LAMINATE STATIC STRENGTH ALLOWABLE TEST MATRIX.

TEST TYPE	LOADING MODE	LAMINATE	TEST ENVIRONMENT					
			LTW	RTW	ETW-1	ETW-2	ETW-3	
UNNOTCHED	TENSION	FD	6	6	-	-	6	
		MD	6	6	-	-	6	
	COMPRESSION	FD	-	6	-	6	6	
		MD	-	6	-	6	6	
OPEN HOLE	TENSION	FD	15(30)	15(30)	6	6	6	
		MD	6	15(30)	6	6	6	
	COMPRESSION	FD	-	6	-	6	-	
		MD	-	6	-	6	-	
FILLED HOLE	COMPRESSION	FD	6	15(30)	6	6	15(30)	
		MD	6	6	6	6	6	
BEARING	TENSION	FD	6	6	6	6	15(30)	
		MD	6	15(30)	6	6	15(30)	
BOLT BEARING BY-PASS	TENSION	20% LT	FD	15(30)	15(30)	-	-	-
			MD	15(30)	15(30)	-	-	-
		30% LT	FD	15(30)	15(30)	-	-	-
			MD	15(30)	15(30)	-	-	-
		50% LT	FD	15(30)	15(30)	-	-	-
			MD	15(30)	15(30)	-	-	-
	COMPRESSION	20% LT	FD	-	15(30)	-	-	15(30)
			MD	-	15(30)	-	-	15(30)
		30% LT	FD	-	15(30)	-	-	15(30)
			MD	-	15(30)	-	-	15(30)
50% LT	FD	-	15(30)	-	-	15(30)		
	MD	-	15(30)	-	-	15(30)		

NOTE: FD = Fiber Dominate Laminate
 MD = Matrix Dominate Laminate
 ETW-3 is the Worst Case Environment
 Numbers in () are for A-Basis Allowables

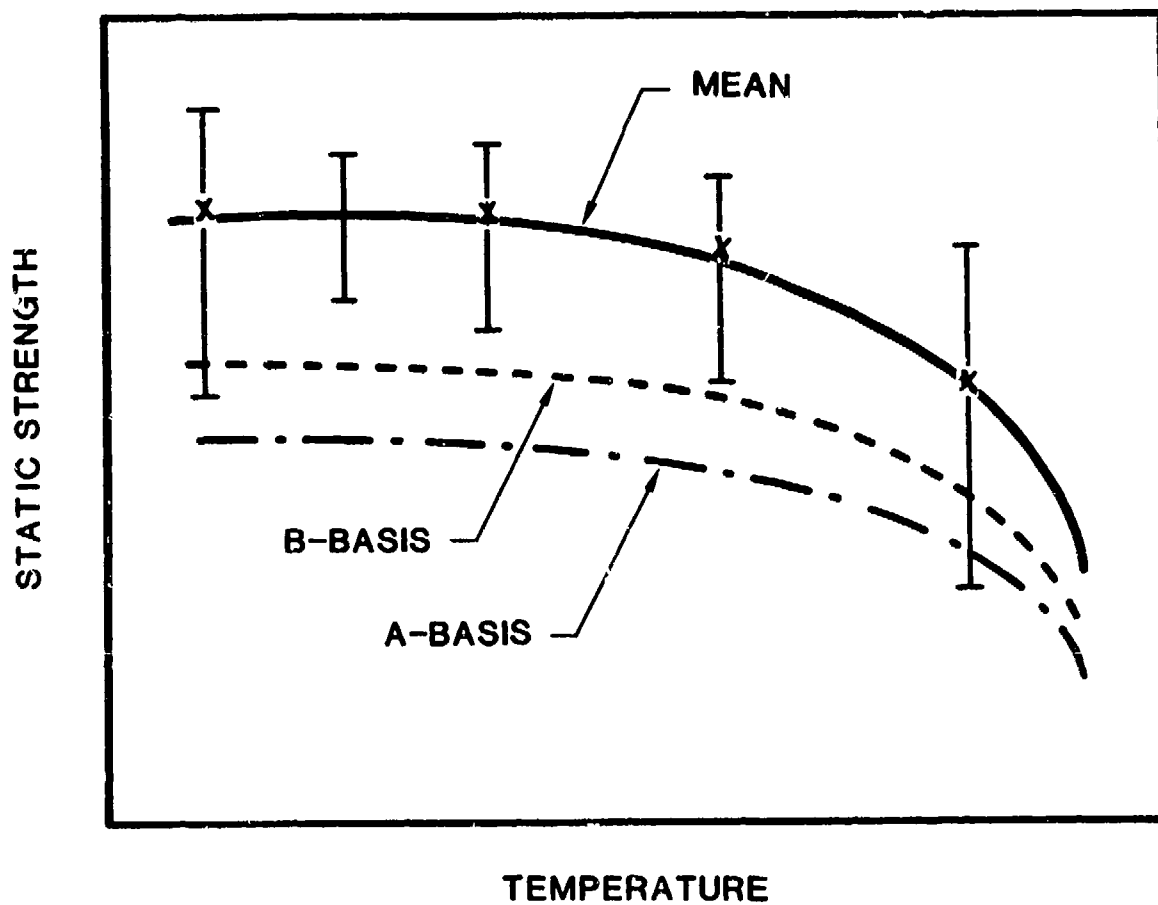

FIGURE 98. DETERMINATION OF DESIGN ALLOWABLES OVER A RANGE OF TEMPERATURE.

than those obtained from the worst case scatter analysis method. However, because the inherent assumption in the analysis that the scatter parameter in each data group is approximately equal, this method must be applied with care. A significance test of the equality of α 's is recommended prior to the application of the joint Weibull analysis. The method of statistical significant test was discussed in Section 2 of Volume I.

The modal value of Weibull shape parameter was determined based on a large amount of static test data over various test parameters. The value of $\alpha(20.0)$ is recommended to be used in computing the design allowables whenever the α value obtained from the allowable tests is higher than 20. When the value of α for the test data is below 20, worst case α should be used.

It is also recommended that the structural response variation (SRV), discussed in Section 3, is incorporated in the computation of design allowables. This can be accomplished by including equation (26) in the design allowable computation. The computer program BSRV or CSRV given in the Appendix can be used for such computations. The incorporation of SRV in the allowable computation will pose an additional penalty to the strength. However, within the range of typical SRV observed in Reference 5, the A- and B-basis knockdown factors are reduced only by a small amount. For a sample size of 15 with the average SRV ($\alpha_{SRV} = 17.0$), the B-basis knockdown factor is reduced from 0.901 to 0.872 for static strength α of 20.0. For the B-basis value of SRV ($\alpha_{SRV} = 13.0$) the knockdown factor reduced from 0.901 to 0.858. With a sample size of 30, the A-basis knockdown factor is reduced from 0.805 to 0.777 when $\alpha_{SRV} = 17.0$ and to 0.762 when $\alpha_{SRV} = 13.0$. The A- and B-basis knockdown factors for $n = 1$ at various values of α_{SRV} are shown in Figure 99.

5.1.1.2 Fatigue Design Allowables

The fatigue design allowables may be determined by the load factor approach, life factor approach or the ultimate strength approach. The individual or joint Weibull analyses are recommended for computation of design allowables. These approaches for fatigue allowable determination are schematically

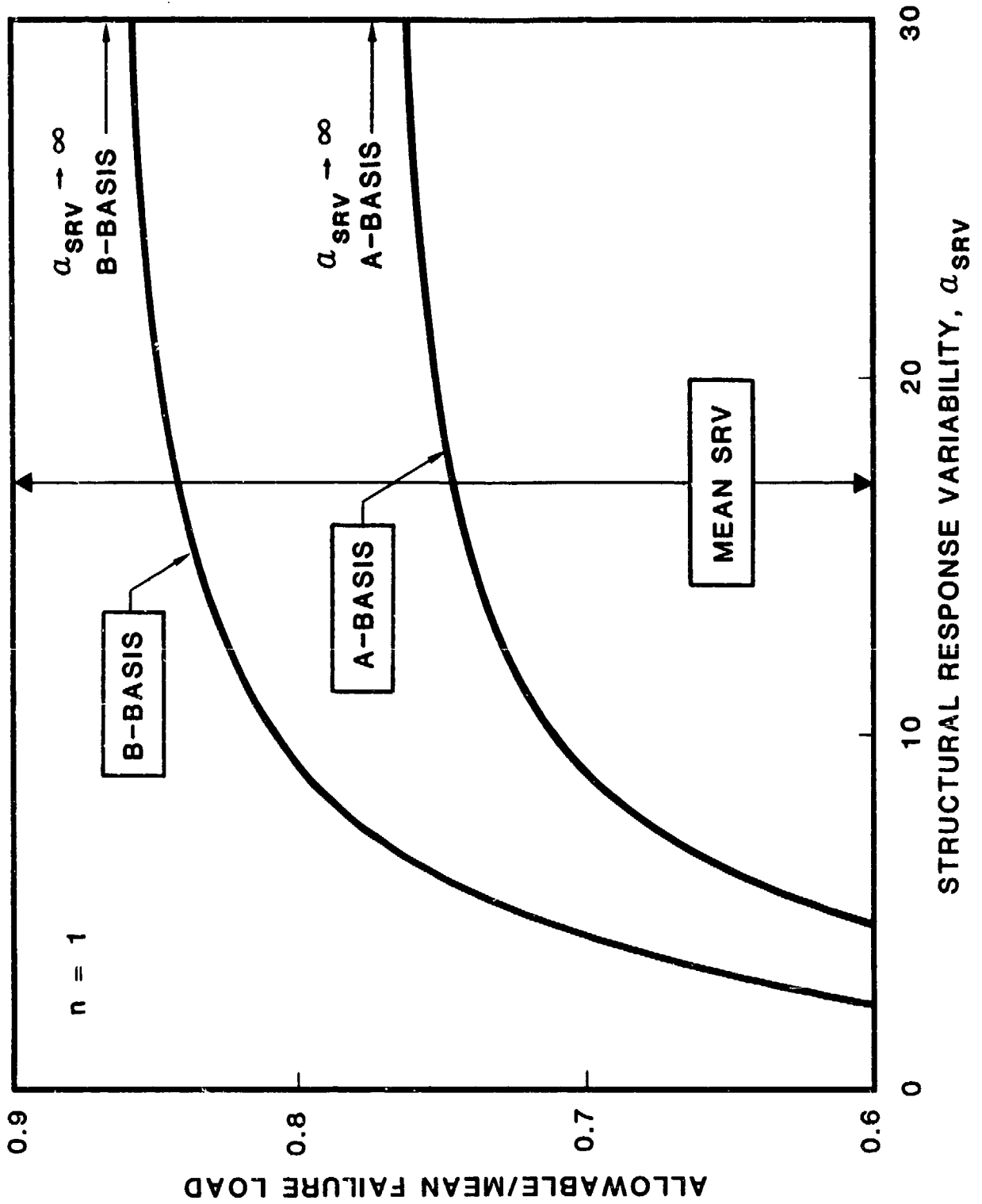

FIGURE 99. INFLUENCE OF SRV ON THE A- AND B-BASIS KNOCKDOWN FACTOR.

shown in Figure 100. Both the load factor approach and the life factor approach require the computation of design fatigue stress level for B- or A-basis fatigue life at one lifetime. For these approaches the joint Weibull analysis is used to define the B- or A-basis stress-life curve. The fatigue allowable strength is then defined as the stress level on the B- or A-basis curve at one fatigue lifetime. The ultimate strength approach is a more conservative approach. In this approach, the fatigue allowable strength is defined as the B- or A-basis stress level below which no fatigue failure will occur. The value σ_{TH}^B shown in Figure 100 is the B-Basis fatigue allowable strength. Although the ultimate strength approach is more conservative, it is recommended that this approach be used to define the fatigue allowable. This is because the flatness of the S-N curve for typical composites, and the high scatter observed in fatigue test data. The value of σ_{TH}^B or σ_{TH}^A is more clearly defined as compared to σ_F^B or σ_F^A . Furthermore, for typical fighter aircraft fatigue load spectra the penalty imposed by this approach is negligible.

The data analysis in Task I have shown that the fatigue life scatter has a modal α factor of 1.25 for typical graphite/epoxy composites. This indicates that fatigue life scatter for composites is considerably higher than that of aluminum. The modal value of α for aluminum under spectrum loading is 7.5. The B-basis to mean life ratio for composites with a sample size of 15 is 0.131 as compared to 0.750 for aluminum.

In planning the fatigue allowable tests, the main consideration is the test environment. The test environment depends on the relationship between the load/temperature spectrum and the MOL. The recommended approach is to use simple conservative constant temperature tests with a constant moisture level. The stress levels used in the fatigue tests should be selected so that the σ_{TH} can be established. For typical graphite/epoxy composites under typical fighter aircraft spectra, the threshold stress level would be approximately 60% of the mean static strength. This would require a minimum of four stress levels for each test condition. From these considerations, using the same

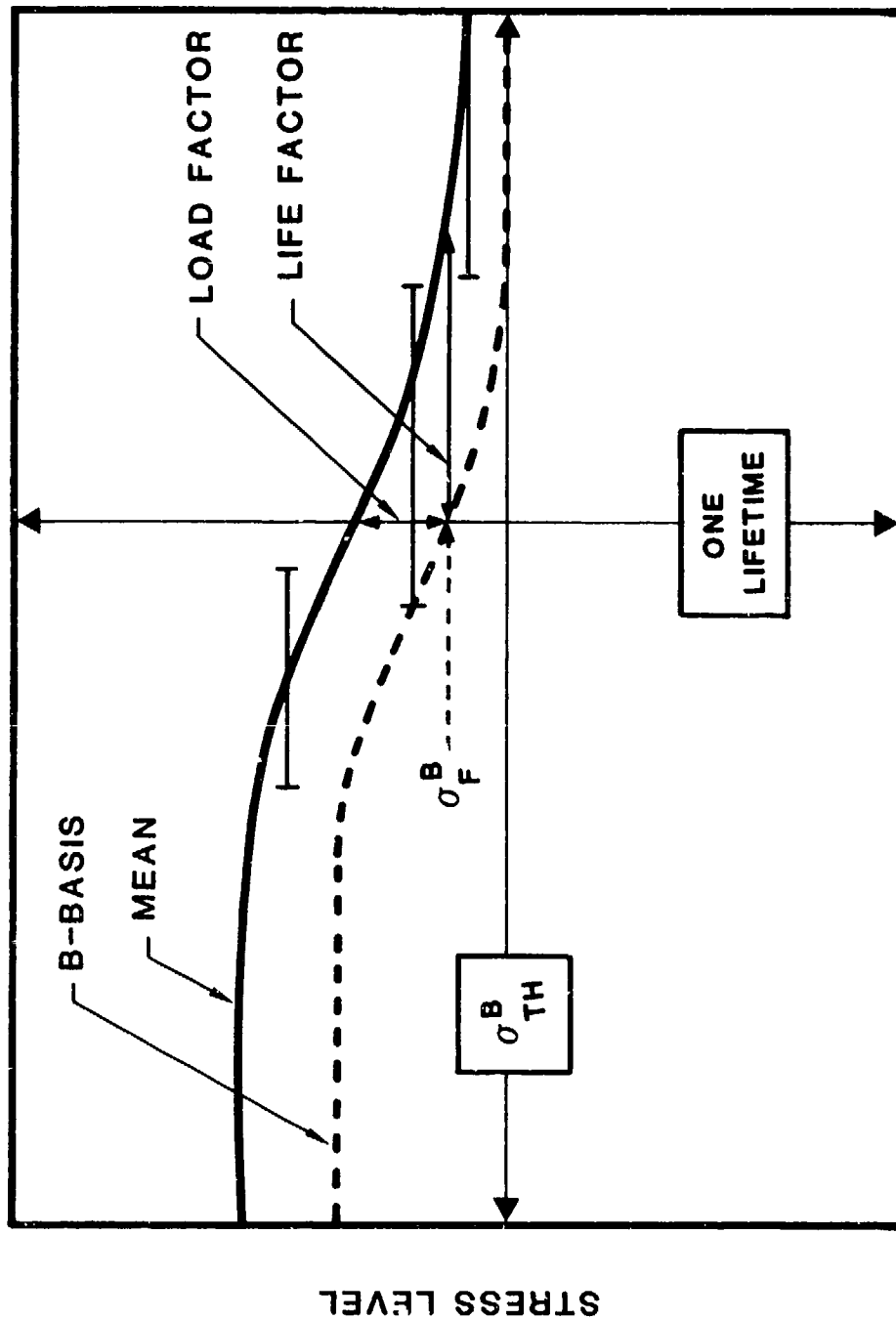

FIGURE 100. FATIGUE ALLOWABLE APPROACHES.

number of specimens required for the static allowable tests (15 for B-basis and 30 for A-basis) a large test matrix would result. However, as discussed in Volume I, the fatigue life scatter does not depend on the stress level for a given test condition. Therefore, the pooling techniques for statistical data analysis are justified. The number of tests at each test condition can therefore be reduced. The recommended number of tests for each test condition is 6 for B-basis and 10 for A-basis. A typical test matrix is shown in Table 32.

It is recommended that all fatigue tests are tested until fatigue failure occurs, except at the lowest stress level. At this stress level, because the fatigue threshold is approached, long life is expected. To reduce the test time, fatigue tests may be censored at a specified lifetime. Based on a life scatter of $\alpha = 1.25$, the test should last for a minimum of 8 lifetimes for B-basis tests and 50 lifetimes for A-basis.

As in the calculation of static strength allowables, it is recommended that SRV be incorporated in the fatigue allowable computations. Because of the large scatter observed in the fatigue life data, the life factor would be impractical for this purpose. The penalty on the load factor imposed by incorporation of SRV is small. The load factor approach is therefore recommended. Typical load enhancement factors required for graphite/epoxy composites ($\alpha_S=20.0$ and $\alpha_L=1.25$) are shown in Table 33. It can be seen from the table that for the average value of SRV ($\alpha_{SRV}=17.0$) the required load factor is increased by approximately 5% for a B-basis allowables. The increase is approximately 10% for A-basis allowables. It may be noted that because of high scatter in fatigue life for composites, B-basis allowable is the most appropriate statistic for fatigue design. This is also consistent with the approach adopted for metal structures, where the average fatigue property with a safety factor of two or four is used for fatigue design.

5.1.2 Design Development Testing

A building block approach to design development testing is essential for the certification of composite structures. This

TABLE 32. RECOMMENDED FATIGUE ALLOWABLE TEST MATRIX.

STRESS LEVEL	TENSION				COMPRESSION				
	RTA	ETW		RTA	ETW		RTA	ETW	
	NO HOLE	NO HOLE	HOLE	NO HOLE	NO HOLE	HOLE	NO HOLE	NO HOLE	HOLE
σ_1	6(10)	6(10)	5	6(10)	6(10)	5	6(10)	6(10)	5
σ_2	6(10)	6(10)	5	6(10)	6(10)	5	6(10)	6(10)	5
σ_3	6(10)	6(10)	5	6(10)	6(10)	5	6(10)	6(10)	5
σ_4	6(10)	6(10)	5	6(10)	6(10)	5	6(10)	6(10)	5

NOTE: Stress Levels are the Maximum Spectrum Stress.
 Numbers in () are the Required Number of Specimens for A-Basis Allowable, Other Numbers are for B-Basis Allowable.

TABLE 33. TYPICAL LOAD FACTORS.

FATIGUE LIFE (Spectrum Lifetimes)	REQUIRED LOAD FACTOR					
	NO SRV		$a_{SRV} = 17.0$ (Mean SRV)		$a_{SRV} = 13.0$ (B-Basis SRV)	
	A	B	A	B	A	B
0.60	1.338	1.197	1.466	1.257	1.556	1.291
0.75	1.305	1.167	1.430	1.226	1.517	1.258
1.00	1.282	1.146	1.404	1.204	1.490	1.236
1.50	1.250	1.117	1.369	1.174	1.453	1.205
2.00	1.227	1.097	1.344	1.153	1.427	1.183
2.50	1.210	1.082	1.326	1.137	1.407	1.167
3.00	1.197	1.070	1.311	1.124	1.391	1.154
3.50	1.185	1.060	1.298	1.113	1.378	1.143
4.00	1.175	1.051	1.287	1.104	1.367	1.133
4.50	1.167	1.043	1.278	1.096	1.357	1.125
5.00	1.159	1.036	1.269	1.089	1.348	1.118

NOTE: A for A-Basis with $n = 10$ B for B-Basis with $n = 6$

is because of the inherent sensitivity of the composite structure to out-of-plane loads and their multiplicity of potential failure modes. Details of the building block approach are discussed in Reference 13 and 21. The essence of the building block approach for composites is as follows. First, use the design/analysis of the aircraft structure to select critical areas for test verification. Second, determine the most strength-critical failure mode for each design feature. Third, select the test environment which will produce the strength critical failure mode. Special attention should be given to matrix sensitive failure modes (such as compression and bondline) and potential stress "hot spots" caused by out-of-plane loads. Following selection of the critical failure modes, a series of specimens is designed, each one to simulate a single failure mode. The specimens will generally be low complexity specimens. However, the crux of the building approach is to also design test specimens which simulate progressive design complexity. In this way, multiple potential failure modes are simulated.

This building block method to design development testing provides a step-by-step approach to composite design development testing which has several advantages.

- The influence of the environment on individual failure mode is determined.
- The interaction of failure modes is established from the known behavior of individual failure modes.
- Scale-up effect is determined from data on smaller scale specimens.
- "Hot spots" induced in complex structure can be analyzed relative to the known behavior of smaller specimens.

Several factors determine the test complexity of composite design development tests. These are: structural geometry complexity, hygrothermal environment simulation, fatigue load spectrum simulation and mixed composite/metal structure.

The levels of complexity in the design development testing should be functions of the design feature being validated and the predicted failure mode. Special attention should be given to correct failure mode simulation since failure modes are frequently dependent on the test environment. In particular, the influence of complex loading on the local stress at a given design feature must be evaluated. In composites, out-of-plane stresses can be detrimental to structural integrity and, therefore, require careful evaluation.

The sensitivity of composite matrix dominated failure modes to the aircraft hygrothermal environment makes environmental test simulation a key issue. Environmental test simulation should be considered separately for static and fatigue testing. However, the static test philosophy will form an integral part of the overall certification philosophy. The static and fatigue testings are discussed in the following paragraphs.

5.1.2.1 Static Tests

The philosophy for design development testing should be that the test environment used is the one that produces the failure mode which gives the lowest static strength. That is the worst case environment, or the temperature associated with most critical load should be used.

The extent of the static test effort will be different from aircraft to aircraft and also from component to component. The number of replicates for each test should be sufficient to identify the critical failure mode and provide a reasonable estimate of the mean strength of the element. The test effort should be concentrated on the most critical design feature of the structure. The number of replicates should be increased for the critical design features. A cost trade-off is usually involved in deciding the levels of complexity and the number of replicates.

If mixed failure modes are observed in a certain specimen type, more tests are required to establish the worst failure mode and the associated mean strength. An example of

mixed failure mode in the design development testing of Reference 5 was discussed in Section 4.3. Two failure modes were observed in the Wing Outboard Fuel Bay Subcomponent (WS-1) tests under 250°F/wet condition. The observed failure modes were upper skin failure and intermediate spar/lower skin cocured joint failure. For WS-1 the intermediate spar/lower skin cocured joint failure mode gave the lower failure load. Thus, the mean strength associated with this failure mode would need to be established.

An example of the building block approach for specimen complexity was given in Figure 57, which shows the approach used for the wing structure in Reference 5. There, the wing structure was broken down into critical areas. Each critical area was simulated in a test specimen whose complexity is governed by the necessity to simulate the predicted failure mode(s). Particular attention was given to matrix critical failure modes. The following recommendations are made for specimen complexity simulation in design development testing:

1. Use the design/analysis of the aircraft structure to select critical areas for test verification.
2. Specimen complexity should be controlled by the requirement to simulate the correct (full-scale structure) failure mode(s) in the specimen.
3. Special attention should be given to matrix sensitive failure modes, such as compression, bondline and hole wear.
4. Potential "hot spots" caused by out-of-plane loads should be carefully evaluated.

5.1.2.2 Fatigue Tests

The environmental complexity necessary for fatigue design development testing will depend on the aircraft hygrothermal history. Three factors must be considered. These are: structural temperature for each mission profile, the load/temperature relationships for the aircraft, and the moisture content as a function of the aircraft usage and structure thickness. In order to obtain these data, it is necessary to derive

the real time load-temperature profiles for each mission in the aircraft's history. These relationships will have a significant influence on the environmental fatigue test requirements.

An example of this approach was given in Reference 5. The aircraft temperature spectrum and load factor/temperature relationships derived from the mission profiles were shown in Figures 20 and 21. These relationships strongly depend on the aircraft type, configuration and mission requirements and must be carefully developed on a case by case basis. The structural material should be selected to meet these mission requirements without exceeding the MOL. If this is accomplished, hot/wet testing would not be required. Material selections which lead to significant environmental fatigue test requirements should be a last resort.

In composite materials, no significant load sequence effect on fatigue life has been observed. However, studies on load spectrum variations have shown that composites are extremely sensitive to variation in the number of high loads in the fatigue spectrum. In contrast, truncation of low loads does not significantly affect fatigue life. Therefore, the following recommendations are made for load spectrum simulation in composite fatigue testing:

1. High loads in the fatigue spectrum must be carefully simulated.
2. Low loads (<30 percent limit load stress) may be truncated to save test time without significantly affecting fatigue life.
3. Fatigue testing of mixed metal/composite structure may introduce conflicting requirements and should be evaluated on an individual basis.

As was discussed in Section 4, the use of fatigue test data to verify fatigue life on subcomponents require long test duration because of the high fatigue life scatter observed in composite structures. The load enhancement factor approach or the ultimate strength approach is recommended in planning the

fatigue design development testing. In the load enhancement factor (LEF) approach, the B- or A-basis LEF is applied to the design load spectrum. A two lifetime fatigue test plus static residual strength test is recommended. Typical LEF for two lifetime tests is approximately 1.15 for a B-Basis reliability with average SRV considered (see Table 33).

In applying the ultimate strength approach, the maximum spectrum load should be kept below the B- or A-basis fatigue threshold. The fatigue life requirements are verified from the static test results. No fatigue tests are required for this approach. This approach provides a conservative estimate of the fatigue reliability.

An alternate for environmental fatigue tests is to use increased loads at RTA condition to account for the environmental effects. An environmental knockdown factor, as discussed in Section 2.1 together with LEF is applied to the fatigue spectrum for RTA fatigue tests. The environmental knockdown factor can be calculated from the results of the design allowable tests. This approach eliminates the environmental fatigue tests. However, in some cases a high load factor may be required and result in a quasi-static failure at the first appearance of the maximum spectrum load. For example, the environmental knockdown factor obtained in Reference 5 for the 242°F/wet condition was 1.31. The B-Basis two lifetime test LEF at the mean SRV is 1.153. From these values, the resulting load factor is 1.51. Therefore, this approach is feasible only if the maximum design spectrum load is below 0.66 of the mean static strength, otherwise quasi-static failure will occur at the peak fatigue load during the RTA fatigue tests. The fatigue reliability will not be verified when this happens.

The number of replicates to be used in the fatigue design development testing should be determined using the same philosophy as in the static tests. A sufficient number must be used to verify the critical failure modes and to reasonably estimate the required fatigue reliability.

5.1.2.3 Mixed Composite/Metal Structures

An analysis of mixed composite/metallic full-scale testing in Reference 8 has shown that:

- The increased environmental sensitivity and material property variability in composites (compared to metals) can lead to inadequate assurance of the static strength integrity of composite structure.
- Because of the superior fatigue performance of composites, a mixed composite/metal structure fatigue will essentially interrogate only the metal structure. Thus, any potential "hot spots" in the composite structure may not be found.

Because of the potential inadequacy of full-scale tests on mixed composite/metal structure and also the natural reluctance to overdesign metal parts in a full-scale test structure, it will be necessary to validate the composite structure during the design development testing phase. However, the specimen complexity should be adequate to enable the performance of the full-scale structure to be correctly simulated. Validation of the composite structure using subcomponent tests can offer the following advantages:

- The components may be chosen for test purposes to interrogate the composite structure only.
- If environmental test conditions are required it will be easier and cheaper to achieve in a component.
- It may be possible to test more than one replicate and thus increase confidence in the data base.
- The results can be utilized in qualification of the full-scale structure.

In order that component tests achieve their objective, great care must be exercised in getting the boundary conditions correct. In addition, eliminating metal failure modes

by overdesign or replacement must be carefully evaluated so that relative effects such as differential thermal expansion are not masked.

It is concluded, therefore, that certification of combined composite/metal structures offer special problems which must be addressed carefully in the design analysis and test phase.

An alternative approach for the certification of mixed structures is the change in spectrum approach, discussed in Section 2.4. The application of this approach involves insertion of overload cycles in the fatigue spectrum in order to reduce the differences in life between metals and composites. The magnitude and frequency of the overload cycles can be determined from life analysis of the metal and composite parts. The introduction of the overload cycles permit demonstration of the B- or A-basis test reliability for both composite and metal parts in a mixed structure. This is achieved without making the test overly severe for metallic structures.

5.1.3 Full-Scale Testing

Following successful conclusion of the design development testing program, qualification culminates in full-scale static and durability tests.

5.1.3.1 Full-Scale Static Test

The full scale static test is the most crucial qualification test for composite structures for the following reasons. Secondary loads are virtually impossible to eliminate from complex built-up structure. Such loads can be produced by eccentricities, stiffness changes, discontinuities, fuel pressure loading and loading in the post-buckled range. Some of these sources of secondary loads are represented for the first time in the full-scale structural test article. These loads are not a significant design driver in metallic structures. However, the poor interlaminar strength of composites makes them extremely

susceptible to out-of-plane secondary loads. It is very important, therefore, to carefully account for these loads in the design of composite structures. Unfortunately, there is a general state of uncertainty as to the source, magnitude and effects of secondary loads in complex built-up full-scale composite structures. This has been confirmed by several documented examples of unanticipated secondary loads leading to unexpected failure modes in full scale composite structural static tests.

Work in Reference 12 has shown that the RTA static test plays the most significant role in revealing unexpected hot spot failures from secondary out-of-plane loads. A room temperature environment is therefore recommended for full scale static test, which should be conducted to failure.

In addition, a detailed correlation in terms of measured load and strain distributions, structural analysis data and environmental effects between the design development and full scale test data will be necessary to provide assurance of composite static strength. Static test environmental degradation must be accounted for separately either by adverse condition testing, by additional test design factors or by correlation with environmental design development test data.

5.1.3.2 Full-Scale Durability Test

Current practice for metallic structures is a two lifetime test using the design load spectrum under RT/ambient test conditions.

The work in Reference 12 and other USAF sponsored programs have shown that composites possess excellent durability. In particular, the extensive data base developed in Reference 12 showed that composite structures, which demonstrated adequate static strength, were fatigue insensitive.

Therefore, it is recommended that no durability full scale test is required for all composite structures or mixed

composite/metal structures with non-fatigue critical metal parts, provided the design development testing and full scale static test are successful. For mixed structure, with fatigue critical metal parts, a two lifetime ambient test will be required to demonstrate durability validation of the metal parts.

5.2 Test Result Interpretation

The certification testing methodology developed in Section 3 is recommended to be used in test result interpretation. The static strength and fatigue life reliabilities should be assessed based on the test data. The procedure for static and fatigue data evaluation was demonstrated in Section 4. This procedure is summarized below.

1. Establish baseline reliability parameters: These parameters are determined from the results of the allowable tests or obtained from the existing data base. The parameters include the static and fatigue life Weibull scatter parameters (α_S and α_L), the structural response variability (α_{SRV}) and environmental knockdown factor (k_{ENV}).
2. Determine the static strength reliability: Both the RTA and worst case environment strength reliabilities should be computed at both DLL and DUL. The reliability is computed based on the test failure load. The reliability calculation methods described in Sections 3 and 4 or the computer programs BSRV or CSRV can be used for any composite structures. However, care should be exercised in computing reliabilities for structures with multiple failure modes because work in Reference 5 has shown that these failure modes can exhibit high scatter in static strength. Reliability analysis of these failures should be conducted on a case-by-case basis using experimentally determined scatter factor (α_S) for the particular failure mode.

3. Determine the required test failure load: The required (minimum) test failure load for each test environment for a specified static strength reliability can be determined using the method developed in Section 3 and 4.
4. Determine the one lifetime fatigue reliability from static strength data: The one lifetime fatigue reliability can be computed using the ultimate strength approach discussed in Section 4 (or computer program BSRV or CSRV). The reliability calculated from this approach is a conservative estimate of the fatigue life reliability. A low reliability based on this approach does not imply that the design feature has poor fatigue strength. It just means that no significant reliability can be inferred from the static strength data. The reliability depends on the maximum spectrum load, the spectrum characteristics, SRV and the static failure load.
5. Determine the fatigue life reliability, using the load enhancement factor approach: The load enhancement factor approach was described in Section 2.2 and the application of this approach, accounting for SRV, was demonstrated in Section 4. Where fatigue failure occurred during test, the actual fatigue life is used to directly assess the fatigue reliability. When fatigue test is terminated without fatigue failure, the test duration (e.g. two lifetimes) is used to conservatively estimate the fatigue reliability.
6. Determine the fatigue life reliability based on the residual strength approach: In the case that the test LEF is not sufficient and the fatigue test is terminated after a short duration, the fatigue reliability demonstrated by the LEF

approach would usually be low. This is typical for composite structures, because of the high fatigue life scatter. For situations like this, residual static strength test to failure is recommended to provide further information on fatigue reliability. The residual static strength data is then used to determine the fatigue life reliability. This approach was demonstrated in Section 4.

SECTION 6

SUMMARY AND CONCLUSIONS

6.1 Summary

The results of this research program are summarized below:

1. An extensive data analysis has been conducted to establish the static strength and fatigue life data scatter for typical glass/epoxy composites.
2. Various approaches to composite structure certification were analytically evaluated. The capability, advantages and disadvantages of each approach were fully discussed.
3. A methodology for certification testing of composite structures has been developed.
4. The methodology was demonstrated on an existing composite structure. The static and fatigue reliabilities of the structure were assessed based on test data.
5. A detailed certification testing approach was presented. Guidelines for test planning and test data interpretation were recommended.

6.2 Conclusions

The following conclusions may be drawn from the investigation undertaken in this program:

1. The Navy approach to static strength certification is, in general, soundly based. In particular, it strikes a good balance between the technical requirements of the test and cost effectiveness. The main area of concern in this approach is the assumed ability to predict full-scale structure failure mode. Because of the inherent sensitivity of composite structures to out-of-plane

secondary loads, a certification process which assumes correct prediction of a full-scale structural failure mode must carry some degree of risk.

2. The high scatter of composite fatigue life data makes life factor approach for fatigue certification very difficult. A practical approach is to use the load enhancement factor approach. In principle, this is equivalent to the Navy Approach of applying severe spectrum in fatigue tests.
3. The incorporation of the structural response variability in the reliability calculations is important in reducing the possibility of "hot spots" failure.
4. Environmental sensitivity is a key issue in design of composite structures. This problem can be avoided by careful selection of materials so that the structure only operates within the material operating limit.
5. Success of certification testing depends on test planning and soundly based data interpretation method.

REFERENCES

1. Weinberger, R.A.; Somoroff, A.R.; and Riley, B.L.; "U.S. Navy Certification of Composite Wings for the F-18 and Advanced Harrier Aircraft," Paper No. 77-466 in AIAA Aircraft Composites: The Emerging Methodology for Structural Assurance, San Diego, California (March 1977).
2. Murray, J.E., "F-18 Composites Development Tests," N00019-79-C-0044 (January 1981).
3. Stenberg, K.V., et al., "YAV-8B Composite Wing Development," Volumes I-III N00019-76-C-0242, 0666 (October 1980).
4. Riley, B.L.; Rintoul, R.D. and Roberts, L.A.; "Certification of Composite Structures," presented at the 5th DOD/NASA Conference on Fibrous Composites in Structural Design, New Orleans, Louisiana (January 1981).
5. Whitehead, R.S. et al "Composite Wing Fuselage Program," Contract F33615-79-C-3203, Interim Reports 1-11, October 1979 - October 1984.
6. Cardrick, A.W., "Proposals for a Common International Approach to Structural Airworthiness Certification," RAE (August 1983).
7. Bohon, H.L., et al., "Ground Test Experience With Large Composite Structures For Commercial Transports," NASA TM 84627 (March 1983).
8. Guyett, P.R. and Cardrick, A.W., "The Certification of Composite Airframe Structures," Paper No. 830/3 Aeronautical Journal (July 1980), pp. 188-203.
9. Whitehead, R.S. and Deo, R.B., "Wing/Fuselage Program Durability Methodology," presented at 6th Mechanics of Composites Review, Dayton, Ohio, November 1980.
10. Whitehead, R.S., "A Review of the Rationale for Durability Validation of Composite Structures," proceedings of the 5th DOD/NASA Conference on Fibrous Composites in Structural Design, New Orleans, Louisiana (January 1981).
11. Whitehead, R.S. and Eves, J.J., "Durability Certification Data for Composite Structures," presented at the 6th DOD/NASA Conference on Fibrous Composites in Structural Design, New Orleans, Louisiana (January 1983).
12. Whitehead, R.S.; Ritchie, G.L. and Mullineaux, J.L.; "Durability of Composites" presented at 9th Mechanics of Composites Review, Dayton, Ohio (October 1983).

13. Whitehead, R.S.; Ritchie, G.L. and Mullineaux, J.L.; "Qualification of Primary Composite Aircraft Structures" to be presented at USAF "Structural Integrity Conference" Macon, Georgia, 27-29 November 1984.
14. Sendekyj, G.P., "Fitting Models to Composite Materials Fatigue Data," ASTM STP 734, 1981, p. 245-260.
15. Whitehead, R.S. and Schwarz, M.G., "The Role of Fatigue Scatter in the Certification of Composite Structures," presented at ASTM Symposium on the Long Term Behavior of Composites, Williamsburg, Virginia (March 1982).
16. Badaliane, R and Dill, H.D., "Compression Fatigue Life Prediction Methodology for Composite Structures," NADC-83060-60 Volumes 1 and 2, September 1982.
17. Ratwani, M.M. and Kan, H.P., "Compression Fatigue Analysis of Fiber Composites," NADC-78049-60 (September 1979).
18. Ratwani, M.M. and Kan, H.P., "Development of Analytical Techniques for Predicting Compression Fatigue Life and Residual Strength of Composites," NADC-82104-60 (March 1982).
19. Porter, P.G., "A Rapid Method to Predict Fatigue Crack Initiation," Report No. NADC-81010-60, February 1983.
20. Mullineaux, J.L., Whitehead, R.S. and Ritchie, G.L., "Full Scale Testing of Composite Wing Structure," Presented at the 7th DOD/NASA Conference on Fibrous Composites in Structural Design, Denver, Colorado (June 1985).
21. Whitehead, R.S. and Deo, R.B., "A Building Block Approach to Design Verification Testing of Primary Composite Structures," Paper No. 83-0947, Proceedings of the 24th AIAA/ASME/ASCE/AHS Structures, Structural Dynamics and Material Conference, Lake Tahoe, Nevada, May 1983, pp. 473-477.

APPENDIX
COMPUTER PROGRAMS

The computer programs used in the data analysis and reliability calculations are documented in this Appendix. The programs are written in FORTRAN language and are suitable to be used on the IBM personal computers. Five programs are included below. The theoretical backgrounds are presented in Section 2 of Volume I and Sections 2 and 3 in this volume. The program listings, input and output descriptions and sample problems are given in the following paragraphs.

A.1 Program "WEIBULL"

The program WEIBULL computes the maximum likelihood estimates (MLE) of Weibull shape and scale parameters. The program also computes the mean, standard deviation and coefficient of variation of the data set based on both normal and Weibull distributions. The A- and B-basis allowables are computed based on the MLE Weibull parameters. A χ^2 goodness-of-fit test is also conducted in the program.

The required input to WEIBULL are:

1. A 32-character problem title (INAME)
2. Total number of data points (N)
3. Number of specimens that failed (NF)
4. Data set mode (MODE) $\text{MODE} \leq 10$ for normal operation mode.
5. Data value and data point ID

ID = 1 specimen failed
ID \neq 1 specimen censored

If $N = NF$, use ID = 1 for all data points. Maximum number of data points is 60.

6. Number of intervals for goodness-of-fit test (INT).

The program listing the input and output of a sample problem are given below.

```

C PROGRAM 'WEIBULL' MLE ESTIMATE OF WEIBULL PARAMETETS FROM DATA
  DOUBLEPRECISION B,Y,CHL,ALPHA,CHIS,GAMMA1,GAM2,ARM1,ARM2,P,S
  DIMENSION ID(60),FR(60),RK(60),INAME(8)
  COMMON/GMA/B(101),Y(101)
  COMMON/CHI/CHL(15)
  OPEN(5,FILE='PSI.DAT')
  READ(5,*) (B(I),I=1,101)
  READ(5,*) (Y(I),I=1,101)
  READ(5,*) (CHL(I),I=1,15)
  PAL = -ALOG(0.99)
  PBL = -ALOG(0.90)
  SUM = 0.0
  SUD = 0.0
  KCOT = 0
  WRITE(*,20)
  READ(*,3) INAME
  WRITE(*,10)
10  FORMAT(2X,'PLEASE ENTER TOTAL NUMBER OF SPECIMENS')
  READ(*,*) N
  WRITE(*,15)
15  FORMAT(2X,'PLEASE ENTER NUMBER OF SPECIMEN THAT FAILED')
  READ(*,*) NF
20  FORMAT(2X,'PLEASE ENTER DATASET NAME: 32 CHARACTERS')
 3  FORMAT(8A4)
  WRITE(*,30)
30  FORMAT(2X,'PLEASE ENTER MODE CODE',
  +/2X,'IF MODE.GE.10 HALF SPECIMENS FAILED, N=NF')
  READ(*,*) MODE
  WRITE(*,41)
41  FORMAT(2X,'SPECIMEN ID CODE: ID=1 SPECIMEN FAILED'
  +/20X,'ID.NE.1 TEST CENSORED')
  DO 35 J = 1,N
  WRITE(*,40) J
40  FORMAT(2X,'ENTER STRENGTH VALUE AND ID FOR SPECIMEN',I3)
  READ(*,*) FR(J),ID(J)
35  CONTINUE
  WRITE(*,50)
50  FORMAT(2X,'ENTER NUMBER OF INTERVALS FOR GOODNESS TEST')
  READ(*,*) INT
  T = N
  N2 = N*2
  ALPHA = 10.0
  WRITE(*,60) INAME
  WRITE(*,65)
  DO 70 I=1,N
  IF(I.EQ.N) GOTO 70
  I1 = I+1
  DO 71 K = I1,N
  IF(FR(I).LE.FR(K)) GOTO 71
  FRT = FR(I)
  FR(I) = FR(K)
  FR(K) = FRT
  IDT = ID(I)
  ID(I) = ID(K)
  ID(K) = IDT

```

```

71 CONTINUE
70 CONTINUE
  FART = ALOG10(FR(1))
  IF(FART.LE.0.5) GOTO 270
  LFA = FART
  RA = 10.0**LFA
  GOTO 271
270 RA = 1.0
271 DO 75 I=1,N
  A = N-I+1
  RK(I) = ^/(T+1.0)
  SUM = SUM+FR(I)
  SUD = SUD+FR(I)*FR(I)
  WRITE(*,80) FR(I),RK(I),ID(I)
75 FR(I) = FR(I)/RA
  AVE = SUM/T
  VA = (SUD-T*AVE*AVE)/(T-1.0)
  STD = SQRT(VA)
  CV = STD/AVE
  IF(CV.LT.0.030) ALPHA = 75.0
65 FORMAT(5X,'ORDERED STRENGTH          ASSIGNED PROBABILITY',4X,'CODE')
80 FORMAT(5X,F12.5,9X,F12.5,12X,I2)
60 FORMAT(2X,'WEIBULL ANALYSIS: ',8A4)
  KKT = 0
85 P = 0.0
  R = 0.0
  S = 0.0
  KCOT = KCOT+1
  IF(KKT.GT.2) GOTO 200
  DO 90 I = 1,N
  ACR = 174.0/ALOG(FR(N))
  IF(ACR.LT.0.0) GOTO 95
  IF(ALPHA.LT.ACR) GOTO 95
  ALPHA = 75.0
  KKT = KKT+1
  GOTO 85
95 P = P+FR(I)**ALPHA
  S = S+FR(I)**ALPHA*ALOG(FR(I))
  IF(ID(I).NE.1) GOTO 90
  R = R+ALOG(FR(I))
90 CONTINUE
  IF(MODE.LT.10) GOTO 98
  P = 2.0*P
  S = 2.0*S
98 ALPH1 = NF*P/(NF*S-P*R)
  DA = ABS(ALPH1-ALPHA)
  IF(DA.LE.0.0001) GOTO 100
  ALPHA = (ALPHA+ALPH1)/2.0
  IF(KCOT.GT.100) GOTO 100
  GOTO 85
100 ALR = 1.0/ALPHA
  BETA = (P/NF)**ALR
  BETA = BETA*RA
  WRITE(*,105) ALPHA,BETA
  WRITE(*,110) KCOT

```

```

105 FORMAT(2X, 'MAX. LIKELIHOOD ESTIMATE OF WEIBULL PARAMETERS: '
      A/2X, 'SHAPE PARAMETER ALHPA =', F12.5
      B/2X, 'SCALE PARAMETER BETA =', F12.5)
110 FORMAT(5X, 'NUMBER OF ITERATIONS KCOT = ', I5)
      CHSQ = CHIS(N)
115 BETAL = BETA/(CHSQ**ALR)
      ALL = BETAL*PAL**ALR
      BLL = BETAL*PBL**ALR
      WRITE(*, 120) BETAL, ALL, BLL
120 FORMAT(2X, '95% CONF. LOWER BETA =', F12.5,
      A      /2X, 'A-BASIS ALLOWABLE =', F12.5
      B      /2X, 'B-BASIS ALLOWABLE =', F12.5)
      WRITE(*, 125) AVE, STD, CV
      ARM1 = 1.0+1.0/ALPHA
      ARM2 = 1.0+2.0/ALPHA
      GAM1 = GAMMA1(ARM1)
      GAM2 = GAMMA1(ARM2)
      XMEAN = BETA*GAM1
      COVS = (GAM2-GAM1*GAM1)/(GAM1*GAM1)
      COV = SQRT(COVS)
      STDW = COV*XMEAN
130 FORMAT(2X, 'WEIBULL: ')
      WRITE(*, 130)
      WRITE(*, 125) XMEAN, STDW, COV
135 FORMAT(6X, 'STRENGTH VALUE      PROBABILITY OF SURVIVAL')
140 FORMAT(2F13.5)
150 FORMAT(4F12.5)
125 FORMAT(2X, 'MEAN STRENGTH      FAVE =', F12.5
      A      /2X, 'STANDARD DEVIATION =', F12.5
      B      /2X, 'COEFF. OF VARIATION =', F12.5)
      DO 155 M=1, N
155 FR(M) = RA*FR(M)
      DF = FR(N)-FR(1)
      WRITE(*, 165)
165 FORMAT(/9X, 'RIGHT END', 5X, 'OBSERVED', 10X, 'EXPECTED', 10X, 'CHI-SQ')
      DIN = DF/INT+0.005
      SUCHI = 0.0
      PENL = EXP(-(FR(1)/BETA)**ALPHA)
      ENRT = FR(1)+DIN
      JK = 1
      RIGHT = FR(N)+0.5*DIN
170 INK = 0
      DO 175 I = JK, N
      IF(FR(I).GT.ENRT) GOTO 180
175 INK = INK+1
180 JK = JK+INK
      PENR = (ENRT/BETA)**ALPHA
      PENR = EXP(-PENR)
      EO = (PENL-PENR)*N
      DEO = EO-INK
      CHI = DEO*DEO/EO
      SUCHI = SUCHI+CHI
      WRITE(*, 185) ENRT, INK, EO, CHI
185 FORMAT(5X, F12.4, 8X, I3, 2(9X, F12.5))
      PENL = PENR

```

```

ENRT = ENRT+DIN
IF(RIGHT.GE.ENRT) GOTO 170
NDOF = INT-3
WRITE(*,190) NDOF,SUCHI
190 FORMAT(/2X,'AT ',I3,'DEGREES OF FREEDOM',
A/2X,'THE CHI-SQUARE VALUE FOR GOODNESS OF FIT IS',2X,F12.5)
FI = FR(1)-0.3*DF
IF(FI.LE.0.0) FI=0.01*DF
DD = DF/40.0
WRITE(*,135)
DO 195 I=1,65
XX = FI+(I-1)*DD
AR = (XX/BETA)**ALPHA
YY = EXP(-AR)
195 WRITE(*,80) XX,YY
200 CONTINUE
STOP
END
FUNCTION CHIS(N)
DOUBLEPRECISION CHL,CHIS,BE,CL
COMMON/CHI/CHL(15)
AN = N
BN = 2.0*AN
IF(N.GE.15) GOTO 50
CHIS = CHL(N)
GOTO 60
50 BE = 1.0/(9.0*AN)
CL = 1.0-BE+1.645*SQRT(BE)
CHIS = CL*CL*CL
60 CONTINUE
RETURN
END
FUNCTION GAMMA1(X)
DOUBLEPRECISION A,B,X,Y,F,ARG,SLOP,GAMMA1
COMMON/GMA/B(101),Y(101)
ARG = X
A = 1.0
IF(ARG.LT.1.0) GOTO 10
IF(ARG.EQ.1.0) GOTO 110
IF(ARG.EQ.2.0) GOTO 110
IF(ARG.GT.2.0) GOTO 20
GOTO 30
10 A = A/ARG
ARG = ARG+1.0
IF(ARG.LT.1.0) GOTO 10
IF(ARG.EQ.1.0) GOTO 110
GOTO 30
20 ARG = ARG-1.0
A = A*ARG
IF(ARG.EQ.2.0) GOTO 110
IF(ARG.GT.2.0) GOTO 20
30 DO 40 I=1,101
IF(B(I).GT.ARG) GOTO 50
40 CONTINUE
50 SLOP = (Y(I)-Y(I-1))/(B(I)-B(I-1))

```

```

      F = Y(I-1)+(ARG-B(I-1))*SLOP
      GOTO 60
110  F = 1.0
      60 GAMMA1 = F*A
      RETURN
      END

```

PSI.DAT TAB VALUES OF CHI-SQUARE AND GAMMA FUNCTIONS

```

1.0, 1.01, 1.02, 1.03, 1.04, 1.05, 1.06, 1.07, 1.08, 1.09, 1.1, 1.11,
1.12, 1.13, 1.14, 1.15, 1.16, 1.17, 1.18, 1.19, 1.2, 1.21, 1.22, 1.23,
1.24, 1.25, 1.26, 1.27, 1.28, 1.29, 1.3, 1.31, 1.32, 1.33, 1.34, 1.35,
1.36, 1.37, 1.38, 1.39, 1.4, 1.41, 1.42, 1.43, 1.44, 1.45, 1.46, 1.47,
1.48, 1.49, 1.5, 1.51, 1.52, 1.53, 1.54, 1.55, 1.56, 1.57, 1.58, 1.59,
1.6, 1.61, 1.62, 1.63, 1.64, 1.65, 1.66, 1.67, 1.68, 1.69, 1.7, 1.71,
1.72, 1.73, 1.74, 1.75, 1.76, 1.77, 1.78, 1.79, 1.8, 1.81, 1.82, 1.83,
1.84, 1.85, 1.86, 1.87, 1.88, 1.89, 1.9, 1.91, 1.92, 1.93, 1.94, 1.95,
1.96, 1.97, 1.98, 1.99, 2.,
1., .99433, .98884, .98355, .97844, .9735, .96874, .96415, .95973,
2.9955, 2.372, 2.09867, 1.93838, 1.8307, 1.75217, 1.69179, 1.6435,
1.60383, 1.5705, 1.542, 1.51729, 1.49558, 1.47632, 1.4591

```

WEIBULL
 PLEASE ENTER DATASET NAME: 32 CHARACTERS
 WEIBULL ANALYSIS: SAMPLE PROBLEM
 PLEASE ENTER TOTAL NUMBER OF SPECIMENS
 10
 PLEASE ENTER NUMBER OF SPECIMEN THAT FAILED
 10
 PLEASE ENTER MODE CODE
 IF MODE.GE.10 HALF SPECIMENS FAILED, N=NF
 0
 SPECIMEN ID CODE: ID=1 SPECIMEN FAILED
 ID.NE.1 TEST CENSORED
 ENTER STRENGTH VALUE AND ID FOR SPECIMEN 1
 4574.000000 1
 ENTER STRENGTH VALUE AND ID FOR SPECIMEN 2
 4705.000000 1
 ENTER STRENGTH VALUE AND ID FOR SPECIMEN 3
 5305.000000 1
 ENTER STRENGTH VALUE AND ID FOR SPECIMEN 4
 5425.000000 1
 ENTER STRENGTH VALUE AND ID FOR SPECIMEN 5
 6631.000000 1
 ENTER STRENGTH VALUE AND ID FOR SPECIMEN 6
 6692.000000 1
 ENTER STRENGTH VALUE AND ID FOR SPECIMEN 7
 7109.000000 1
 ENTER STRENGTH VALUE AND ID FOR SPECIMEN 8
 7392.000000 1
 ENTER STRENGTH VALUE AND ID FOR SPECIMEN 9
 7590.000000 1
 ENTER STRENGTH VALUE AND ID FOR SPECIMEN 10
 7757.000000 1
 ENTER NUMBER OF INTERVALS FOR GOODNESS TEST
 5

WEIBULL ANALYSIS: WEIBULL ANALYSIS: SAMPLE PROBLEM

ORDERED STRENGTH	ASSIGNED PROBABILITY	CODE
4574.00000	.90909	1
4705.00000	.81818	1
5305.00000	.72727	1
5425.00000	.63636	1
6631.00000	.54545	1
6692.00000	.45455	1
7109.00000	.36364	1
7392.00000	.27273	1
7590.00000	.18182	1
7757.00000	.09091	1

MAX. LIKELIHOOD ESTIMATE OF WEIBULL PARAMETERS:
 SHAPE PARAMETER ALHPA = 6.74585
 SCALE PARAMETER BETA = 6793.37500
 NUMBER OF ITERATIONS KCOT = 10
 95% CONF. LOWER BETA = 6353.67600
 A-BASIS ALLOWABLE = 3212.69700
 B-BASIS ALLOWABLE = 4551.42700
 MEAN STRENGTH FAVE = 6318.00000
 STANDARD DEVIATION = 1209.80300

COEFF. OF VARIATION = .19149
 WEIBULL:
 MEAN STRENGTH FAVE = 6342.53400
 STANDARD DEVIATION = 1102.71200
 COEFF. OF VARIATION = .17386

RIGHT END	OBSERVED	EXPECTED	CHI-SQ
5210.6050	2	.86846	1.47433
5847.2100	2	1.50956	.15934
6483.8150	0	2.13309	2.13309
7120.4200	3	2.28595	.22305
7757.0250	3	1.66725	1.06536

AT 2DEGREES OF FREEDOM
 THE CHI-SQUARE VALUE FOR GOODNESS OF FIT IS 5.05516
 STRENGTH VALUE PROBABILITY OF SURVIVAL

3619.10000	.98581
3698.67500	.98359
3778.25000	.98107
3857.82500	.97825
3937.40000	.97508
4016.97500	.97153
4096.55000	.96756
4176.12500	.96315
4255.70000	.95826
4335.27500	.95283
4414.85000	.94684
4494.42500	.94024
4574.00000	.93299
4653.57500	.92504
4733.15000	.91634
4812.72500	.90686
4892.30000	.89655
4971.87500	.88536
5051.45000	.87326
5131.02500	.86020
5210.60000	.84614
5290.17500	.83106
5369.75000	.81492
5449.32500	.79771
5528.90000	.77940
5608.47500	.75999
5688.05000	.73947
5767.62500	.71787
5847.20000	.69519
5926.77500	.67147
6006.35000	.64676
6085.92500	.62112
6165.50000	.59461
6245.07500	.56732
6324.65000	.53936
6404.22500	.51084
6483.80000	.48188
6563.37500	.45263
6642.95000	.42325

6722.52500	.39388
6802.10000	.36469
6881.67500	.33587
6961.25000	.30758
7040.82500	.28000
7120.40000	.25329
7199.97500	.22761
7279.55000	.20310
7359.12500	.17990
7438.70000	.15811
7518.27500	.13784
7597.85000	.11913
7677.42500	.10203
7757.00000	.08656
7836.57500	.07271
7916.15000	.06044
7995.72500	.04968
8075.30000	.04038
8154.87500	.03242
8234.44900	.02570
8314.02500	.02011
8393.60000	.01552
8473.17500	.01180
8552.75000	.00884
8632.32400	.00652
8711.90000	.00473

1

A.2 Program "WEIBJNT"

The program WEIBJNT is used for joint Weibull analysis of pooled data. The program computes the joint MLE Weibull shape parameter for the pooled data, the scale parameter, A- and B-basis allowables, mean, standard deviation and coefficient of variation of each individual data set. The program also prints the normalized joint Weibull distribution.

The required input to WEIBJNT are:

1. A 32-character problem title (INAME)
2. Number of data sets (M)
3. Number of data points in the Ith data set (NC(I))
4. Number of specimens failed in the Ith data set (NF(I))
5. Data value and ID for the Jth specimen in the Ith data set (FR(I,J)), ID(I,J))

ID(I,J) = 1 specimen failed
 ID(I,J) ≠ 1 specimen censored

Input item 5 is repeat N(I) times for the N(I) specimens.
 Input items 3,4 and 5 are repeat M times for M sets of data.

The program listing, the input and output of a sample example are given below:

```

C PROGRAM 'WEIBJNT' JOINT MLE OF WEIBULL PARAMETERS
  DOUBLEPRECISION B,Y,CHL,ALPHA,CHIS,GAMMA1,GAM1,GAM2,ARM1,ARM2
  DIMENSION ID(10,15),FR(10,15),RA(10),INAME(8),P(10),N(10),NF(10)
  DIMENSION F(150),IDN(150),IMN(150)
  COMMON/GMA/B(101),Y(101)
  COMMON/CHI/CHL(15)
  OPEN(5,FILE='PSI.DAT')
  READ(5,*) (B(I),I=1,101)
  READ(5,*) (Y(I),I=1,101)
  READ(5,*) (CHL(I),I=1,15)
  PAL = -ALOG(0.99)
  PBL = -ALOG(0.90)
  NM = 0
  KCOT = 0
  WRITE(*,20)
10  FORMAT(2X,'PLEASE ENTER NO. OF SPECIMENS IN DATA SET',I3)
  READ(*,3) INAME
  WRITE(*,501)
  READ(*,*) M
501  FORMAT(2X,'PLEASE ENTER NUMBER OF DATA SETS')
  DO 502 I =1,M
  WRITE(*,10) I
15  FORMAT(2X,'PLEASE ENTER NO. OF FAILURES IN DATA SET',I3)
  READ(*,*) N(I)
  NM = NM+N(I)
  WRITE(*,15) I
20  FORMAT(2X,'PLEASE ENTER A 32-CHARACTER PROBLEM TITLE')
  READ(*,*) NF(I)
  3  FORMAT(8A4)
  WRITE(*,41)
41  FORMAT(2X,'SPECIMEN ID CODE: ID=1 FAILURE, ID.NE.1 CENSORED')
  DO 35 J = 1,N(I)
  WRITE(*,40) J
40  FORMAT(2X,'ENTER DATA VALUE AND ID FOR SPECIMEN 'I3)
  READ(*,*) FR(I,J),ID(I,J)
35  CONTINUE
502  CONTINUE
  WRITE(*,60) INAME
  WRITE(*,503) M
  ALPHA = 10.0
503  FORMAT(2X,'TOTAL NUMBER OF DATA SETS M = ',I3)
  DO 505 I=1,M
  WRITE(*,504) I
504  FORMAT(//2X,'DATA SET NO.',I3)
  WRITE(*,506) N(I),NF(I)
506  FORMAT(2X,'NUMBER OF SPECIMENS ='I3,3X,'NUMBER OF FAILURES',I3)
  SUM = 0.0
  SUD = 0.0
  WRITE(*,65)
65  FORMAT(/5X,'ORDER DATA',9X,'ASSD. PROB.',13X,'CODE')
  DO 70 J=1,N(I)
  IF(J.EQ.N(I)) GOTO 70
  I1 = J+1
  DO 71 K=I1,N(I)
  IF(FR(I,J).LE.FR(I,K)) GOTO 71

```

```

FRT = FR(I,J)
FR(I,J) = FR(I,K)
FR(I,K) = FRT
IDT = ID(I,J)
ID(I,J) = ID(I,K)
ID(I,K) = IDT
71 CONTINUE
70 CONTINUE
FART = ALOG10(FR(I,1))
IF(FART.LE.0.5) GOTO 270
LFA = FART
RA(I) = 10.0**LFA
GOTO 271
270 RA(I) = 1.0
271 DO 75 J=1,N(I)
A = N(I)-J+1.0
RK = A/(N(I)+1.0)
SUM = SUM+FR(I,J)
SUD = SUD+FR(I,J)*FR(I,J)
WRITE(*,80) FR(I,J),RK,ID(I,J)
75 FR(I,J) = FR(I,J)/RA(I)
AVE = SUM/N(I)
VA = (SUD-N(I)*AVE*AVE)/(N(I)-1.0)
STD = SQRT(VA)
CV = STD/AVE
80 FORMAT(5X,F12.3,9X,F12.5,12X,I2)
60 FORMAT(///2X,'JOINT WEIBULL ANALYSIS: ',8A4)
WRITE(*,125) AVE,STD,CV
505 CONTINUE
85 PM = 0.0
RM = 0.0
KCOT = KCOT+1
DO 510 I=1,M
P(I) = 0.0
R = 0.0
S = 0.0
DO 90 J=1,N(I)
T = FR(I,J)**ALPHA
TL = ALOG(FR(I,J))
P(I) = P(I)+T
S = S+T*TL
IF(ID(I,J).NE.1) GOTO 90
R = R+TL
90 CONTINUE
PM = PM+S/P(I)
RM = RM+R/NF(I)
510 CONTINUE
ALPH1 = M/(PM-RM)
DA = ABS(ALPH1-ALPHA)
IF(DA.LE.0.0001) GOTO 100
ALPHA = (ALPHA+ALPH1)/2.0
IF(KCOT.GT.100) GOTO 100
GOTO 85
100 ALPHA = (ALPHA+ALPH1)/2.0
ALR = 1.0/ALPHA

```

```

WRITE(*,110) KCOT
WRITE(*,508) ALPHA
508 FORMAT(5X,'JOINT MLE WEIBULL ALPHA =',F12.5)
110 FORMAT(5X,'NUMBER OF ITERATIONS KCOT = ',I5)
CHSQ = CHIS(NM)
120 FORMAT(2X,'SCALE PARAMETER BETA =',F13.5
A      /2X,'95% CONF. LOWER BETA =',F13.5
A      /2X,'A-BASIS ALLOWABLE   =',F13.5
B      /2X,'B-BASIS ALLOWABLE   =',F13.5)
ARM1 = 1.0+1.0/ALPHA
ARM2 = 1.0+2.0/ALPHA
GAM1 = GAMMA1(ARM1)
GAM2 = GAMMA1(ARM2)
COVS = (GAM2-GAM1*GAM1)/(GAM1*GAM1)
COV = SQRT(COVS)
IN = 0
DO 511 I=1,M
WRITE(*,512) I
512 FORMAT(///2X,'WEIBULL STATISTICS FOR DATA SET',I3)
BETA = (P(I)/NF(I))**ALR
DO 513 J=1,N(I)
F(IN+J) = FR(I,J)/BETA
IDN(IN+J) = ID(I,J)
IMN(IN+J) = I
513 CONTINUE
BETA = BETA*RA(I)
BETAL = BETA/(CHSQ**ALR)
ALL = BETAL*PAL**ALR
BLL = BETAL*PBL**ALR
XMEAN = BETA*GAM1
STDW = COV*XMEAN
WRITE(*,120) BETA,BETAL,ALL,BLL
WRITE(*,125) XMEAN,STDW,COV
125 FORMAT(/2X,'MEAN STRENGTH   FAVE =',F13.5
A      /2X,'STANDARE DEVIATION   =',F13.5
B      /2X,'COEFF. OF VARIATION   =',F13.5)
IN = IN+N(I)
511 CONTINUE
WRITE(*,533)
533 FORMAT(///2X,'NORMALIZED JOINT WEIBULL DISTRIBUTION',
A      /2X,'NORM. VALUE',3X,'GROUP',4X,'CODE',3X,'ASSD. PRCB.',4X
B      , 'CALC. PRCB. ')
DO 530 I = 1,NM
IF(I.EQ.NM) GOTO 532
I1 = I+1
DO 531 J=I1,NM
IF(F(I).LE.F(J)) GOTO 531
FRT = F(I)
F(I) = F(J)
F(J) = FRT
IDT = IDN(I)
IDN(I) = IDN(J)
IDN(J) = IDT
IMT = IMN(I)
IMN(I) = IMN(J)

```

```

      IMN(J) = IMT
531 CONTINUE
532 RK = (NM-I+1.0)/(NM+1.0)
      PRB = EXP(-F(I)**ALPHA)
      WRITE(*,534) F(I),IMN(I),IDN(I),RK,PRB
530 CONTINUE
534 FORMAT(4X,F9.5,5X,I3,6X,I2,4X,F9.5,4X,F9.5)
      STOP
      END
      FUNCTION CHIS(N)
      DOUBLEPRECISION CHL,CHIS,BE,CL
      COMMON/CHI/CHL(15)
      AN = N
      BN = 2.0*AN
      IF(N.GE.15) GOTO 50
      CHIS = CHL(N)
      GOTO 60
50 BE = 1.0/(9.0*AN)
      CL = 1.0-BE+1.645*SQRT(BE)
      CHIS = CL*CL*CL
60 CONTINUE
      RETURN
      END
      FUNCTION GAMMA1(X)
      DOUBLEPRECISION A,B,X,Y,F,ARG,SLOP,GAMMA1
      COMMON/GMA/B(101),Y(101)
      ARG = X
      A = 1.0
      IF(ARG.LT.1.0) GOTO 10
      IF(ARG.EQ.1.0) GOTO 110
      IF(ARG.EQ.2.0) GOTO 110
      IF(ARG.GT.2.0) GOTO 20
      GOTO 30
10 A = A/ARG
      ARG = ARG+1.0
      IF(ARG.LT.1.0) GOTO 10
      IF(ARG.EQ.1.0) GOTO 110
      GOTO 30
20 ARG = ARG-1.0
      A = A*ARG
      IF(ARG.EQ.2.0) GOTO 110
      IF(ARG.GT.2.0) GOTO 20
30 DO 40 I=1,101
      IF(B(I).GT.ARG) GOTO 50
40 CCNTINUE
50 SLOP = (Y(I)-Y(I-1))/(B(I)-B(I-1))
      F = Y(I-1)+(ARG-B(I-1))*SLOP
      GOTO 60
110 F = 1.0
60 GAMMA1 = F*A
      RETURN
      END

```

PSI.DAT TAB VALUES OF CHI-SQUARE AND GAMMA FUNCTIONS

1.0, 1.01, 1.02, 1.03, 1.04, 1.05, 1.06, 1.07, 1.08, 1.09, 1.1, 1.11,
 1.12, 1.13, 1.14, 1.15, 1.16, 1.17, 1.18, 1.19, 1.2, 1.21, 1.22, 1.23,
 1.24, 1.25, 1.26, 1.27, 1.28, 1.29, 1.3, 1.31, 1.32, 1.33, 1.34, 1.35,
 1.36, 1.37, 1.38, 1.39, 1.4, 1.41, 1.42, 1.43, 1.44, 1.45, 1.46, 1.47,
 1.48, 1.49, 1.5, 1.51, 1.52, 1.53, 1.54, 1.55, 1.56, 1.57, 1.58, 1.59,
 1.6, 1.61, 1.62, 1.63, 1.64, 1.65, 1.66, 1.67, 1.68, 1.69, 1.7, 1.71,
 1.72, 1.73, 1.74, 1.75, 1.76, 1.77, 1.78, 1.79, 1.8, 1.81, 1.82, 1.83,
 1.84, 1.85, 1.86, 1.87, 1.88, 1.89, 1.9, 1.91, 1.92, 1.93, 1.94, 1.95,
 1.96, 1.97, 1.98, 1.99, 2.,
 1., .99433, .98884, .98355, .97844, .9735, .96874, .96415, .95973,
 2.9955, 2.372, 2.09867, 1.93838, 1.8307, 1.75217, 1.69179, 1.6435,
 1.60383, 1.5705, 1.542, 1.51729, 1.49558, 1.47632, 1.4591

WEIBJNT
PLEASE ENTER A 32-CHARACTER PROBLEM TITLE
JOINT WEIBULL ANALYSIS SAMPLE
PLEASE ENTER NUMBER OF DATA SETS
9
PLEASE ENTER NO. OF SPECIMENS IN DATA SET 1
5
PLEASE ENTER NO. OF FAILURES IN DATA SET 1
5
SPECIMEN ID CODE: ID=1 FAILURE, ID.NE.1 CENSORED
ENTER DATA VALUE AND ID FOR SPECIMEN 1
673.0000000 1
ENTER DATA VALUE AND ID FOR SPECIMEN 2
704.0000000 1
ENTER DATA VALUE AND ID FOR SPECIMEN 3
718.0000000 1
ENTER DATA VALUE AND ID FOR SPECIMEN 4
1334.0000000 1
ENTER DATA VALUE AND ID FOR SPECIMEN 5
1511.0000000 1
PLEASE ENTER NO. OF SPECIMENS IN DATA SET 2
5
PLEASE ENTER NO. OF FAILURES IN DATA SET 2
5
SPECIMEN ID CODE: ID=1 FAILURE, ID.NE.1 CENSORED
ENTER DATA VALUE AND ID FOR SPECIMEN 1
181104.0000000 1
ENTER DATA VALUE AND ID FOR SPECIMEN 2
192966.0000000 1
ENTER DATA VALUE AND ID FOR SPECIMEN 3
222450.0000000 1
ENTER DATA VALUE AND ID FOR SPECIMEN 4
248974.0000000 1
ENTER DATA VALUE AND ID FOR SPECIMEN 5
440585.0000000 1
PLEASE ENTER NO. OF SPECIMENS IN DATA SET 3
5
PLEASE ENTER NO. OF FAILURES IN DATA SET 3
5
SPECIMEN ID CODE: ID=1 FAILURE, ID.NE.1 CENSORED
ENTER DATA VALUE AND ID FOR SPECIMEN 1
1652870.0000000 1
ENTER DATA VALUE AND ID FOR SPECIMEN 2
1922982.0000000 1
ENTER DATA VALUE AND ID FOR SPECIMEN 3
2530135.0000000 1
ENTER DATA VALUE AND ID FOR SPECIMEN 4
2793310.0000000 1
ENTER DATA VALUE AND ID FOR SPECIMEN 5
2986175.0000000 1
PLEASE ENTER NO. OF SPECIMENS IN DATA SET 4
5
PLEASE ENTER NO. OF FAILURES IN DATA SET 4
5
SPECIMEN ID CODE: ID=1 FAILURE, ID.NE.1 CENSORED

ENTER DATA VALUE AND ID FOR SPECIMEN 1
 95914.0000000 1
 ENTER DATA VALUE AND ID FOR SPECIMEN 2
 167338.0000000 1
 ENTER DATA VALUE AND ID FOR SPECIMEN 3
 399000.0000000 1
 ENTER DATA VALUE AND ID FOR SPECIMEN 4
 440228.0000000 1
 ENTER DATA VALUE AND ID FOR SPECIMEN 5
 499495.0000000 1
 PLEASE ENTER NO. OF SPECIMENS IN DATA SET 5
 5
 PLEASE ENTER NO. OF FAILURES IN DATA SET 5
 5
 SPECIMEN ID CODE: ID=1 FAILURE, ID.NE.1 CENSORED
 ENTER DATA VALUE AND ID FOR SPECIMEN 1
 4000.0000000 1
 ENTER DATA VALUE AND ID FOR SPECIMEN 2
 7934.0000000 1
 ENTER DATA VALUE AND ID FOR SPECIMEN 3
 8000.0000000 1
 ENTER DATA VALUE AND ID FOR SPECIMEN 4
 10703.0000000 1
 ENTER DATA VALUE AND ID FOR SPECIMEN 5
 24000.0000000 1
 PLEASE ENTER NO. OF SPECIMENS IN DATA SET 6
 5
 PLEASE ENTER NO. OF FAILURES IN DATA SET 6
 5
 SPECIMEN ID CODE: ID=1 FAILURE, ID.NE.1 CENSORED
 ENTER DATA VALUE AND ID FOR SPECIMEN 1
 16747.0000000 1
 ENTER DATA VALUE AND ID FOR SPECIMEN 2
 18707.0000000 1
 ENTER DATA VALUE AND ID FOR SPECIMEN 3
 21822.0000000 1
 ENTER DATA VALUE AND ID FOR SPECIMEN 4
 116786.0000000 1
 ENTER DATA VALUE AND ID FOR SPECIMEN 5
 172710.0000000 1
 PLEASE ENTER NO. OF SPECIMENS IN DATA SET 7
 5
 PLEASE ENTER NO. OF FAILURES IN DATA SET 7
 5
 SPECIMEN ID CODE: ID=1 FAILURE, ID.NE.1 CENSORED
 ENTER DATA VALUE AND ID FOR SPECIMEN 1
 20204.0000000 1
 ENTER DATA VALUE AND ID FOR SPECIMEN 2
 20440.0000000 1
 ENTER DATA VALUE AND ID FOR SPECIMEN 3
 26376.0000000 1
 ENTER DATA VALUE AND ID FOR SPECIMEN 4
 44875.0000000 1
 ENTER DATA VALUE AND ID FOR SPECIMEN 5
 65151.0000000 1

PLEASE ENTER NO. OF SPECIMENS IN DATA SET 8
 2
 PLEASE ENTER NO. OF FAILURES IN DATA SET 8
 2
 SPECIMEN ID CODE: ID=1 FAILURE, ID.NE.1 CENSORED
 ENTER DATA VALUE AND ID FOR SPECIMEN 1
 1124317.0000000 1
 ENTER DATA VALUE AND ID FOR SPECIMEN 2
 1865990.0000000 1
 PLEASE ENTER NO. OF SPECIMENS IN DATA SET 9
 5
 PLEASE ENTER NO. OF FAILURES IN DATA SET 9
 5
 SPECIMEN ID CODE: ID=1 FAILURE, ID.NE.1 CENSORED
 ENTER DATA VALUE AND ID FOR SPECIMEN 1
 1851.0000000 1
 ENTER DATA VALUE AND ID FOR SPECIMEN 2
 2581.0000000 1
 ENTER DATA VALUE AND ID FOR SPECIMEN 3
 3298.0000000 1
 ENTER DATA VALUE AND ID FOR SPECIMEN 4
 5376.0000000 1
 ENTER DATA VALUE AND ID FOR SPECIMEN 5
 7530.0000000 1

JOINT WEIBULL ANALYSIS: JOINT WEIBULL ANALYSIS SAMPLE
 TOTAL NUMBER OF DATA SETS M = 9

DATA SET NO. 1
 NUMBER OF SPECIMENS = 5 NUMBER OF FAILURES 5

ORDER DATA	ASSD. PROB.	CODE
673.000	.83333	1
704.000	.66667	1
718.000	.50000	1
1334.000	.33333	1
1511.000	.16667	1

MEAN STRENGTH FAVE = 988.00000
 STANDARE DEVIATION = 401.87870
 COEFF. OF VARIATION = .40676

DATA SET NO. 2
 NUMBER OF SPECIMENS = 5 NUMBER OF FAILURES 5

ORDER DATA	ASSD. PROB.	CODE
181104.000	.83333	1
192966.000	.66667	1
222450.000	.50000	1
248974.000	.33333	1
440585.000	.16667	1

MEAN STRENGTH FAVE = 257215.80000
 STANDARE DEVIATION = 105855.90000
 COEFF. OF VARIATION = .41155

DATA SET NO. 3
 NUMBER OF SPECIMENS = 5 NUMBER OF FAILURES 5

ORDER DATA	ASSD. PROB.	CODE
1652870.000	.83333	1
1922982.000	.66667	1
2530135.000	.50000	1
2793310.000	.33333	1
2986175.000	.16667	1

MEAN STRENGTH FAVE = 2377095.00000
 STANDARE DEVIATION = 569726.90000
 COEFF. OF VARIATION = .23967

DATA SET NO. 4
 NUMBER OF SPECIMENS = 5 NUMBER OF FAILURES 5

ORDER DATA	ASSD. PROB.	CODE
95914.000	.83333	1
167338.000	.66667	1
399000.000	.50000	1
440228.000	.33333	1
499495.000	.16667	1

MEAN STRENGTH FAVE = 320395.00000
 STANDARE DEVIATION = 177787.60000
 COEFF. OF VARIATION = .55490

DATA SET NO. 5
 NUMBER OF SPECIMENS = 5 NUMBER OF FAILURES 5

ORDER DATA	ASSD. PROB.	CODE
4000.000	.83333	1
7934.000	.66667	1
8000.000	.50000	1
10703.000	.33333	1
24000.000	.16667	1

MEAN STRENGTH FAVE = 10927.40000
 STANDARE DEVIATION = 7688.66400
 COEFF. OF VARIATION = .70361

DATA SET NO. 6
 NUMBER OF SPECIMENS = 5 NUMBER OF FAILURES 5

ORDER DATA	ASSD. PROB.	CODE
------------	-------------	------

16747.000	.83333	1
18707.000	.66667	1
21822.000	.50000	1
116786.000	.33333	1
172710.000	.16667	1

MEAN STRENGTH FAVE = 69354.40000
 STANDARE DEVIATION = 71631.28000
 COEFF. OF VARIATION = 1.03283

DATA SET NO. 7
 NUMBER OF SPECIMENS = 5 NUMBER OF FAILURES 5

ORDER DATA	ASSD. PROB.	CODE
20204.000	.83333	1
20440.000	.66667	1
26376.000	.50000	1
44875.000	.33333	1
65151.000	.16667	1

MEAN STRENGTH FAVE = 35409.20000
 STANDARE DEVIATION = 19436.12000
 COEFF. OF VARIATION = .54890

DATA SET NO. 8
 NUMBER OF SPECIMENS = 2 NUMBER OF FAILURES 2

ORDER DATA	ASSD. PROB.	CODE
1124317.000	.66667	1
1865990.000	.33333	1

MEAN STRENGTH FAVE =1495154.00000
 STANDARE DEVIATION = 524442.00000
 COEFF. OF VARIATION = .35076

DATA SET NO. 9
 NUMBER OF SPECIMENS = 5 NUMBER OF FAILURES 5

ORDER DATA	ASSD. PROB.	CODE
1851.000	.83333	1
2581.000	.66667	1
3298.000	.50000	1
5376.000	.33333	1
7530.000	.16667	1

MEAN STRENGTH FAVE = 4127.20000
 STANDARE DEVIATION = 2312.89600
 COEFF. OF VARIATION = .56040
 NUMBER OF ITERATIONS KCOT = 11
 JOINT MLE WEIBULL ALPHA = 2.19728

WEIBULL STATISTICS FOR DATA SET 1
 SCALE PARAMETER BETA = 1063.57000
 95% CONF. LOWER BETA = 955.11270
 A-BASIS ALLOWABLE = 117.71500
 B-BASIS ALLOWABLE = 342.97940

MEAN STRENGTH FAVE = 941.92400
 STANDARE DEVIATION = 452.45610
 COEFF. OF VARIATION = .48035

WEIBULL STATISTICS FOR DATA SET 2
 SCALE PARAMETER BETA = 277660.40000
 95% CONF. LOWER BETA = 249346.00000
 A-BASIS ALLOWABLE = 30731.19000
 B-BASIS ALLOWABLE = 89539.72000

MEAN STRENGTH FAVE = 245902.80000
 STANDARE DEVIATION = 118120.20000
 COEFF. OF VARIATION = .48035

WEIBULL STATISTICS FOR DATA SET 3
 SCALE PARAMETER BETA =2441181.00000
 95% CONF. LOWER BETA =2192241.00000
 A-BASIS ALLOWABLE = 270187.50000
 B-BASIS ALLOWABLE = 787230.10000

MEAN STRENGTH FAVE =2161969.00000
 STANDARE DEVIATION =1038509.00000
 COEFF. OF VARIATION = .48035

WEIBULL STATISTICS FOR DATA SET 4
 SCALE PARAMETER BETA = 363389.80000
 95% CONF. LOWER BETA = 326333.10000
 A-BASIS ALLOWABLE = 40219.63000
 B-BASIS ALLOWABLE = 117185.70000

MEAN STRENGTH FAVE = 321826.80000
 STANDARE DEVIATION = 154590.50000
 COEFF. OF VARIATION = .48035

WEIBULL STATISTICS FOR DATA SET 5
 SCALE PARAMETER BETA = 13299.10000
 95% CONF. LOWER BETA = 11942.92000
 A-BASIS ALLOWABLE = 1471.93100
 B-BASIS ALLOWABLE = 4288.68300

MEAN STRENGTH FAVE = 11778.00000
 STANDARE DEVIATION = 5657.60000
 COEFF. OF VARIATION = .48035

WEIBULL STATISTICS FOR DATA SET 6
 SCALE PARAMETER BETA = 98244.48000
 95% CONF. LOWER BETA = 88225.99000
 A-BASIS ALLOWABLE = 10873.61000
 B-BASIS ALLOWABLE = 31681.80000

MEAN STRENGTH FAVE = 87007.71000
 STANDARE DEVIATION = 41794.42000
 COEFF. OF VARIATION = .48035

WEIBULL STATISTICS FOR DATA SET 7
 SCALE PARAMETER BETA = 40220.67000
 95% CONF. LOWER BETA = 36119.16000
 A-BASIS ALLOWABLE = 4451.58500
 B-BASIS ALLOWABLE = 12970.33000

MEAN STRENGTH FAVE = 35620.41000
 STANDARE DEVIATION = 17110.37000
 COEFF. OF VARIATION = .48035

WEIBULL STATISTICS FOR DATA SET 8
 SCALE PARAMETER BETA = 1549015.00000
 95% CONF. LOWER BETA = 1391054.00000
 A-BASIS ALLOWABLE = 171443.50000
 B-BASIS ALLOWABLE = 499525.10000

MEAN STRENGTH FAVE = 1371845.00000
 STANDARE DEVIATION = 658970.00000
 COEFF. OF VARIATION = .48035

WEIBULL STATISTICS FOR DATA SET 9
 SCALE PARAMETER BETA = 4707.17900
 95% CONF. LOWER BETA = 4227.16400
 A-BASIS ALLOWABLE = 520.98610
 B-BASIS ALLOWABLE = 1517.96800

MEAN STRENGTH FAVE = 4168.79200
 STANDARE DEVIATION = 2002.49200
 COEFF. OF VARIATION = .48035

NORMALIZED JOINT WEIBULL DISTRIBUTION

NORM. VALUE	GROUP	CODE	ASSD. PROB.	CALC. PROB.
.17046	6	1	.97674	.97971
.19041	6	1	.95349	.97420
.22212	6	1	.93023	.96400
.26394	4	1	.90698	.94784
.30077	5	1	.88372	.93111
.39323	9	1	.86047	.87930
.46049	4	1	.83721	.83363
.50233	7	1	.81395	.80229
.50820	7	1	.79070	.79773
.54831	9	1	.76744	.76565
.59658	5	1	.74419	.72511
.60154	5	1	.72093	.72084
.63277	1	1	.69767	.69362
.65225	2	1	.67442	.67636
.65578	7	1	.65116	.67321
.66192	1	1	.62791	.66772
.67508	1	1	.60465	.65590
.67708	3	1	.58140	.65410
.69497	2	1	.55814	.63793
.70063	9	1	.53488	.63279
.72583	8	1	.51163	.60984
.78773	3	1	.48837	.55323
.80116	2	1	.46512	.54097
.80479	5	1	.44186	.53766
.89669	2	1	.41860	.45524
1.03644	3	1	.39535	.33898
1.09799	4	1	.37209	.29287
1.11572	7	1	.34884	.28027
1.14209	9	1	.32558	.26211
1.14425	3	1	.30233	.26065
1.18873	6	1	.27907	.23175
1.20463	8	1	.25581	.22192
1.21145	4	1	.23256	.21779
1.22325	3	1	.20930	.21076
1.25427	1	1	.18605	.19300
1.37454	4	1	.16279	.13375
1.42069	1	1	.13953	.11497
1.58678	2	1	.11628	.06342
1.59968	9	1	.09302	.06036
1.61984	7	1	.06977	.05581
1.75796	6	1	.04651	.03161
1.80463	5	1	.02326	.02576

A.3 Program "LOAD"

This program computes the Load Enhancement Factor by given strength and life scatter parameter, sample size and fatigue test duration. The required input are

1. Residual strength Weibull shape parameter (ALPR)
2. Fatigue life Weibull shape parameter (ALPL)
3. Sample size (N)
4. Fatigue test duration (T)

The program listing, input and output of a sample problem are given below:

```

C LOAD.FOR COMPUTES LOAD ENHANCEMENT FACTOR BASED ON WEIBULL
COMMON/GMA/B(101),Y(101)
COMMON/CHI/CHL(15)
OPEN(5,FILE='PSI.DAT')
READ(5,*) (B(I),I=1,101)
READ(5,*) (Y(I),I=1,101)
READ(5,*) (CHL(I),I=1,15)
PAL = -ALOG(0.99)
PBL = -ALOG(0.90)
WRITE(*,1)
1 FORMAT(2X,'THIS PROGRAM COMPUTES THE LOAD ENHANCEMENT FACTOR'
A/2X,'THE REQUIRED INPUT ARE STRENGTH AND LIFE WEIBULL ALPHA,'
B/2X,'SAMPLE SIZE AND FATIGUE TEST DURATION'
C/2X,'PLEASE INPUT STRENGTH ALPHA')
READ(*,*) ALPR
ALPRI = 1.0/ALPR
WRITE(*,2)
2 FORMAT(2X,'PLEASE INPUT LIFE ALPHA')
READ(*,*) ALPL
ALPLI = 1.0/ALPL
WRITE(*,3)
3 FORMAT(2X,'PLEASE INPUT SAMPLE SIZE')
READ(*,*) N
AN = N
WRITE(*,4)
4 FORMAT(2X,'PLEASE INPUT TEST DURATION')
READ(*,*) T
RALP = ALPL/ALPR
ARGR = 1.0+ALPRI
ARGL = 1.0+ALPLI
GR = GAMMA1(ARGR)
GL = GAMMA1(ARGL)
CHSQ = CHIS(N)
AM = (GL**RALP)/GR
AA = PAL*(T**ALPL)
AB = PBL*(T**ALPL)
BA = (AA/CHSQ)**ALPRI
BB = (AB/CHSQ)**ALPRI
FA = AM*GR/BA
FB = AM*GR/BB
TA = GL/((PAL/CHSQ)**ALPLI)
TB = GL/((PBL/CHSQ)**ALPLI)
WRITE(*,5) ALPR,ALPL,N
WRITE(*,6) TA,TB
WRITE(*,7) T,FA,FB
5 FORMAT(2X,'STRENGTH ALPHA = ',F9.5
A /2X,'LIFE ALPHA = ',F9.5
B /2X,'SAMPLE SIZE = ',I5)
6 FORMAT(2X,'A-BASIS LIFE FACTOR = ',F9.5
A /2X,'B-BASIS LIFE FACTOR = ',F9.5)
7 FORMAT(2X,'TEST DURATION = ',F7.4
A /2X,'A-BASIS LOAD ENHANCEMENT FACTOR = ',F9.5
B /2X,'B-BASIS LOAD ENHANCEMENT FACTOR = ',F9.5)
STOP
END

```

```

FUNCTION CHIS(N)
COMMON/CHI/CHL(15)
AN = N
BN = 2.0*AN
IF(N.GE.15) GOTO 50
CHIS = CHL(N)
GOTO 60
50 B = 1.0/(9.0*AN)
CL = 1.0-B+1.645*SQRT(B)
CHIS = CL*CL*CL
60 CONTINUE
RETURN
END
FUNCTION GAMMA1(X)
COMMON/GMA/B(101),Y(101)
ARG = X
A = 1.0
IF(ARG.LT.1.0) GOTO 10
IF(ARG.EQ.1.0) GOTO 110
IF(ARG.EQ.2.0) GOTO 110
IF(ARG.GT.2.0) GOTO 20
GOTO 30
10 A = A/ARG
ARG = ARG+1.0
IF(ARG.LT.1.0) GOTO 10
IF(ARG.EQ.1.0) GOTO 110
GOTO 30
20 ARG = ARG-1.0
A = A*ARG
IF(ARG.GT.2.0) GOTO 20
IF(ARG.EQ.2.0) GOTO 110
30 DO 40 I=1,101
IF(B(I).GT.ARG) GOTO 50
40 CONTINUE
50 SLOP = (Y(I)-Y(I-1))/(B(I)-B(I-1))
F = Y(I-1)+(ARG-B(I-1))*SLOP
GOTO 60
110 F = 1.0
60 GAMMA1 = F*A
RETURN
END

```

PSI.DAT TAB VALUES OF CHI-SQUARE AND GAMMA FUNCTIONS

```

1.0, 1.01, 1.02, 1.03, 1.04, 1.05, 1.06, 1.07, 1.08, 1.09, 1.1, 1.11,
1.12, 1.13, 1.14, 1.15, 1.16, 1.17, 1.18, 1.19, 1.2, 1.21, 1.22, 1.23,
1.24, 1.25, 1.26, 1.27, 1.28, 1.29, 1.3, 1.31, 1.32, 1.33, 1.34, 1.35,
1.36, 1.37, 1.38, 1.39, 1.4, 1.41, 1.42, 1.43, 1.44, 1.45, 1.46, 1.47,
1.48, 1.49, 1.5, 1.51, 1.52, 1.53, 1.54, 1.55, 1.56, 1.57, 1.58, 1.59,
1.6, 1.61, 1.62, 1.63, 1.64, 1.65, 1.66, 1.67, 1.68, 1.69, 1.7, 1.71,
1.72, 1.73, 1.74, 1.75, 1.76, 1.77, 1.78, 1.79, 1.8, 1.81, 1.82, 1.83,
1.84, 1.85, 1.86, 1.87, 1.88, 1.89, 1.9, 1.91, 1.92, 1.93, 1.94, 1.95,
1.96, 1.97, 1.98, 1.99, 2.,
1., .99433, .98884, .98355, .97844, .9735, .96874, .96415, .95973,
2.9955, 2.372, 2.09867, 1.93838, 1.8307, 1.75217, 1.69179, 1.6435,
1.60383, 1.5705, 1.542, 1.51729, 1.49558, 1.47632, 1.4591

```

LOAD
THIS PROGRAM COMPUTES THE LOAD ENHANCEMENT FACTOR
THE REQUIRED INPUT ARE STRENGTH AND LIFE WEIBULL ALPHA,
SAMPLE SIZE AND FATIGUE TEST DURATION
PLEASE INPUT STRENGTH ALPHA
20.000000
PLEASE INPUT LIFE ALPHA
1.250000
PLEASE INPUT SAMPLE SIZE
5
PLEASE INPUT TEST DURATION
2.000000
STRENGTH ALPHA = 20.00000
LIFE ALPHA = 1.25000
SAMPLE SIZE = 5
A-BASIS LIFE FACTOR = 59.90686
B-BASIS LIFE FACTOR = 9.14278
TEST DURATION = 2.0000
A-BASIS LOAD ENHANCEMENT FACTOR = 1.23674
B-BASIS LOAD ENHANCEMENT FACTOR = 1.09965

A.4 Program "ALLOW"

This program computes the A- and B-basis allowables by either given the Weibull shape parameter (α) or the coefficient of variation (CV) and the sample size.

The program listing and the results of two sample problems are given below. The first example uses $\alpha = 20.0$ and $n = 5$. The second example uses $CV = 0.065$ and $n = 5$.

```

C ALLOW.FOR COMPUTES A AND B BASIS ALLOWABLES BASED ON WEIBULL
COMMON/GMA/B(101),Y(101)
COMMON/CHI/CHL(15)
OPEN(5,FILE='PSI.DAT')
READ(5,*) (B(I),I-1,101)
READ(5,*) (Y(I),I-1,101)
READ(5,*) (CHL(I),I-1,15)
PAL = -ALOG(0.99)
PBL = -ALOG(0.90)
WRITE(*,1)
WRITE(*,101)
WRITE(*,102)
WRITE(*,103)
WRITE(*,104)
WRITE(*,105)
1 FORMAT(2X,'THIS PROGRAM COMPUTES THE A- AND B-BASIS ALLOWABLES')
101 FORMAT(2X,'THE REQUIRED INPUT ARE COEFFICIENT OF VARIATION OR')
102 FORMAT(2X,'WEIBULL SHAPE PARAMETER, ALPHA AND SAMPLE SIZE')
103 FORMAT(2X,'PLEASE ENTER CASE CONTROL ID')
104 FORMAT(2X,'IF ALPHA IS GIVEN ENTER "0" AND HIT RETURN')
105 FORMAT(2X,'IF CV IS GIVEN ENTER ANY INTEGER AND HIT RETURN')
READ(*,*) ID
WRITE(*,4)
READ(*,*) N
IF(ID.EQ.0) GOTO 20
WRITE(*,2)
2 FORMAT(2X,'PLEASE INPUT COEFFICIENT OF VARIATION: CV')
READ(*,*) CV
DT = 0.0001
AL1 = (1.0/CV)**1.07
10 ARG1 = 1.0+1.0/AL1
ARG2 = 1.0+2.0/AL1
GM1 = GAMMA1(ARG1)
GM2 = GAMMA1(ARG2)
SG = GM2-GM1*GM1
SG = SQRT(SG)
CV1 = SG/GM1
DC = (CV-CV1)/CV
DC = ABS(DC)
IF(DC.LT.DT) ALPHA = AL1
IF(DC.LT.DT) GOTO 30
AL1 = AL1*CV1/CV
GOTO 10
20 WRITE(*,3)
3 FORMAT(2X,'PLEASE INPUT ALPHA')
READ(*,*) ALPHA
30 ARG = 1.0+1.0/ALPHA
GM = GAMMA1(ARG)
ALPI = 1.0/ALPHA
4 FORMAT(2X,'PLEASE INPUT SAMPLE SIZE N')
AN = N
BET = 1.0/GM
CHSQ = CHIS(N)
ALLA = ((PAL/CHSQ)**ALPI)*BET
ALLB = ((PBL/CHSQ)**ALPI)*BET

```

```

WRITE(*,5) ALPHA
WRITE(*,106) BET
WRITE(*,107) ALLA
WRITE(*,108) ALLB
  5 FORMAT(2X,'ALPHA - ',F9.5)
106 FORMAT(2X,'BETA - ',F9.5)
107 FORMAT(2X,'A-ALLOWABLE - ',F9.5)
108 FORMAT(2X,'B-ALLOWABLE - ',F9.5)
STOP
END
FUNCTION CHIS(N)
COMMON/CHI/CHL(15)
AN = N
BN =2.0*AN
IF(N.GE.15) GOTO 50
CHIS = CHL(N)
GOTO 60
50 B = 1.0/(9.0*AN)
CL = 1.0-B+1.645*SQRT(B)
CHIS = CL*CL*CL
60 CONTINUE
RETURN
END
FUNCTION GAMMA1(X)
COMMON/GMA/B(101),Y(101)
ARG = X
A = 1.0
IF(ARG.LT.1.0) GOTO 10
IF(ARG.EQ.1.0) GOTO 110
IF(ARG.EQ.2.0) GOTO 110
IF(ARG.GT.2.0) GOTO 20
GOTO 30
10 A = A/ARG
ARG = ARG+1.0
IF(ARG.LT.1.0) GOTO 10
IF(ARG.EQ.1.0) GOTO 110
GOTO 30
20 ARG = ARG-1.0
A = A*ARG
IF(ARG.GT.2.0) GOTO 20
IF(ARG.EQ.2.0) GOTO 110
30 DO 40 I=1,101
IF(B(I).GT.ARG) GOTO 50
40 CONTINUE
50 SLOP = (Y(I)-Y(I-1))/(B(I)-B(I-1))
F = Y(I-1)+(ARG-B(I-1))*SLOP
GOTO 60
110 F = 1.0
60 GAMMA1 = F*A
RETURN
END

```

PSI.DAT TAB VALUES OF CHI-SQUARE AND GAMMA FUNCTIONS

1.0, 1.01, 1.02, 1.03, 1.04, 1.05, 1.06, 1.07, 1.08, 1.09, 1.1, 1.11,
1.12, 1.13, 1.14, 1.15, 1.16, 1.17, 1.18, 1.19, 1.2, 1.21, 1.22, 1.23,
1.24, 1.25, 1.26, 1.27, 1.28, 1.29, 1.3, 1.31, 1.32, 1.33, 1.34, 1.35,
1.36, 1.37, 1.38, 1.39, 1.4, 1.41, 1.42, 1.43, 1.44, 1.45, 1.46, 1.47,
1.48, 1.49, 1.5, 1.51, 1.52, 1.53, 1.54, 1.55, 1.56, 1.57, 1.58, 1.59,
1.6, 1.61, 1.62, 1.63, 1.64, 1.65, 1.66, 1.67, 1.68, 1.69, 1.7, 1.71,
1.72, 1.73, 1.74, 1.75, 1.76, 1.77, 1.78, 1.79, 1.8, 1.81, 1.82, 1.83,
1.84, 1.85, 1.86, 1.87, 1.88, 1.89, 1.9, 1.91, 1.92, 1.93, 1.94, 1.95,
1.96, 1.97, 1.98, 1.99, 2.,
1., .99433, .98884, .98355, .97844, .9735, .96874, .96415, .95973,
2.9955, 2.372, 2.09867, 1.93838, 1.8307, 1.75217, 1.69179, 1.6435,
1.60383, 1.5705, 1.542, 1.51729, 1.49558, 1.47632, 1.4591

ALLOW
 THIS PROGRAM COMPUTES THE A- AND B-BASIS ALLOWABLES
 THE REQUIRED INPUT ARE COEFFICIENT OF VARIATION OR
 WEIBULL SHAPE PARAMETER, ALPHA AND SAMPLE SIZE
 PLEASE ENTER CASE CONTROL ID
 IF ALPHA IS GIVEN ENTER "0" AND HIT RETURN
 IF CV IS GIVEN ENTER ANY INTEGER AND HIT RETURN
 0
 PLEASE INPUT SAMPLE SIZE N
 5
 PLEASE INPUT ALPHA
 20.0000000
 ALPHA = 20.00000
 BETA = 1.02722
 A-ALLOWABLE = .79185
 B-ALLOWABLE = .89057

ALLOW
 THIS PROGRAM COMPUTES THE A- AND B-BASIS ALLOWABLES
 THE REQUIRED INPUT ARE COEFFICIENT OF VARIATION OR
 WEIBULL SHAPE PARAMETER, ALPHA AND SAMPLE SIZE
 PLEASE ENTER CASE CONTROL ID
 IF ALPHA IS GIVEN ENTER "0" AND HIT RETURN
 IF CV IS GIVEN ENTER ANY INTEGER AND HIT RETURN
 1
 PLEASE INPUT SAMPLE SIZE N
 5
 PLEASE INPUT COEFFICIENT OF VARIATION: CV
 6.500000E-002
 ALPHA = 19.01858
 BETA = 1.02852
 A-ALLOWABLE = .78227
 B-ALLOWABLE = .88515

A.5 Programs "BSRV" and "CSRV"

These two programs compute the structural static and fatigue reliability, taken into consideration of the structural response variability (SRV). The programs are similar, except in their input. BSRV require more input and shorter computation time. Both programs have seven cases of reliability computations. These cases and their corresponding input are discussed below.

Case 1: Compute static reliability at a specified load level. The required input are:

1. Static strength α_s (ALM)
2. SRV α_{SRV} (ALS)
3. Gamma function value for ALS (GAS) for BSRV
Number of specimen (N) for CSRV
4. $\hat{\beta}$, 95% confidence lower limit of static strength
 β (BET) for BSRV
Mean static strength (XB) for CSRV
5. Applied load level (AK)

In using BSRV the parameters GAS and BET must be pre-computed using the following equations

$$\hat{\beta} = \bar{x} / \Gamma(1 + 1/\alpha_s)$$

$$\hat{\beta} = \hat{\beta} / [\chi^2(2n)/2n]^{1/\alpha_s}$$

The values of χ^2 are given in Table A-1 and values of Γ are given in Table A-2. The relation between CV and are given in Table A-3. Example runs for Case 1 static reliability are given below.

TABLE A-1. VALUES OF $\chi^2(2n)/2n$ AT F = 0.95

n	$\chi_{.95}(2n)/2n$
1	2.99550
2	2.37200
3	2.09867
4	1.93838
5	1.83070
6	1.75217
7	1.69179
8	1.64350
9	1.60383
10	1.57050
11	1.54200
12	1.51729
13	1.49558
14	1.47632
15	1.45910
16	1.44344
17	1.42935
18	1.41653
19	1.40474
20	1.39388
22	1.37450
25	1.35004
30	1.31800
40	1.27349
50	1.24342

TABLE A-2. VALUES OF $\Gamma(1+\frac{1}{\alpha})$

α	$\Gamma(1+\frac{1}{\alpha})$	α	$\Gamma(1+\frac{1}{\alpha})$
0.1	3,628,800	10.0	0.95135
0.125	40,320	11.0	0.95509
0.15	2593.6	12.0	0.95831
0.18	318.1225	13.0	0.96109
0.20	120.0	14.0	0.96352
0.25	24.0	15.0	0.96568
0.30	9.26067	16.0	0.96759
0.40	3.32336	17.0	0.96930
0.50	2.0	18.0	0.97086
0.75	1.19066	19.0	0.97225
1.00	1.00000	20.0	0.97350
		22.0	0.97575
1.25	0.93138	23.2	0.97691
1.50	0.90276	24.0	0.97762
1.75	0.89062	25.0	0.97844
2.00	0.88623	26.0	0.97923
2.17	0.88560	27.5	0.98030
2.25	0.88573	30.0	0.98185
2.50	0.88726	32.5	0.98316
2.75	0.88986	35.0	0.98431
3.00	0.89299	37.5	0.98531
3.50	0.89976	40.0	0.98620
4.00	0.90640	45.0	0.98766
4.50	0.91259	50.0	0.98884
5.00	0.91817	60.0	0.99067
5.50	0.92321	70.0	0.99198
6.00	0.92773	80.0	0.99296
6.50	0.93179	90.0	0.99372
7.00	0.93545	100.0	0.99433
7.50	0.93876		
8.00	0.94176		
8.80	0.94601		
9.00	0.94697		

TABLE A-3 RELATION BETWEEN WEIBULL SHAPE PARAMETER (α) AND COEFFICIENT OF VARIATION (CV)

α	CV	α	CV
0.1	429.83	10.0	0.12032
0.125	113.44	11.0	0.10992
0.15	47.036	12.0	0.10107
0.18	22.731	13.0	0.09364
0.20	15.843	14.0	0.08737
0.25	8.3066	15.0	0.08168
0.30	5.4076	16.0	0.07682
0.40	3.1408	17.0	0.07252
0.50	2.2361	18.0	0.06838
0.75	1.3528	19.0	0.06506
1.00	1.0000	20.0	0.06204
		21.0	0.05906
1.25	0.80501	22.0	0.05620
1.50	0.67896	23.0	0.05393
1.75	0.58975	23.2	0.05351
2.00	0.52271	24.0	0.05188
2.17	0.48579	25.0	0.04991
2.50	0.42791	26.0	0.04797
3.00	0.36342	27.0	0.04608
3.50	0.31642	28.0	0.04426
4.00	0.28056	29.0	0.04269
4.50	0.25208	30.0	0.04146
5.00	0.22904	32.0	0.03911
6.00	0.19373	34.0	0.03689
7.00	0.16796	36.0	0.03475
7.50	0.15751	38.0	0.03271
8.00	0.14823	40.0	0.03075
8.80	0.13561	45.0	0.02797
9.00	0.13290	50.0	0.02549

Note $CV = \frac{\sqrt{\Gamma(1+2/a) - \Gamma^2(1+1/a)}}{\Gamma(1+1/a)}$

BSRV

PLEASE INPUT ANALYSIS CASE NUMBER

CASE 1--STATIC RELIABILITY WITH SRV

CASE 2--FATIGUE REL., ULT. STRENGTH WITH SRV

CASE 3--FATIGUE REL., ULT. STRENGTH WITH SRV

CASE 4--FATIGUE REL., LEF APPROACH WITH SRV

CASE 5--FATIGUE REL., LEF APPROACH WITH SRV

CASE 6--FATIGUE REL., RES. STRENGTH WITH SRV

CASE 7--FATIGUE REL., RES. STRENGTH WITH SRV

1

CASE 1, STATIC REL. WITH SRV

PLEASE INPUT STATIC STRENGTH ALPHA

20.0000000

PLEASE INPUT SRV ALPHA

17.0000000

PLEASE INPUT SRV GAMMA

9.693000E-001

PLEASE INPUT LOWER STRENGTH BETA

1.0280000

PLEASE INPUT LOAD LEVEL

1.1500000

AT LOAD LEVEL OF 1.150

THE STRUCTURAL RELIABILITY IS .0771640

CSRV

PLEASE INPUT ANALYSIS CASE NUMBER

CASE 1--STATIC RELIABILITY WITH SRV

CASE 2--FATIGUE REL., ULT. STRENGTH WITH SRV

CASE 3--FATIGUE REL., ULT. STRENGTH WITH SRV

CASE 4--FATIGUE REL., LEF APPROACH WITH SRV

CASE 5--FATIGUE REL., LEF APPROACH WITH SRV

CASE 6--FATIGUE REL., RES. STRENGTH WITH SRV

CASE 7--FATIGUE REL., RES. STRENGTH WITH SRV

1

CASE 1, STATIC REL. WITH SRV

PLEASE INPUT STATIC STRENGTH ALPHA

20.0000000

PLEASE INPUT SRV ALPHA

17.0000000

PLEASE INPUT NUMBER OF SPECIMENS

5

PLEASE INPUT MEAN STATIC STRENGTH

1.0000000

PLEASE INPUT LOAD LEVEL

1.1500000

AT LOAD LEVEL OF 1.150

THE STRUCTURAL RELIABILITY IS .0468499

Cases 2 and 3: These two cases compute the fatigue reliability at one lifetime using the ultimate strength approach. Case 2 performs computation with general input parameters and Case 3 uses some fixed parameter values that are frequently encountered. The required input are:

1. Static strength α_S and Gamma value (ALM, GAM)
 GAM is not required in CSRV
 ALM = 20.0 and GAM = 0.9735 in Case 3. These values are not required for Case 3.
2. SRV α_{SRV} and Gamma value (ALS, GAS)
 GAS not required in CSRV
3. Fatigue spectrum characteristic parameter (CON)

$$CON = \frac{\sigma_S^M}{\sigma_{TH}^M} \cdot \frac{\sigma_{TH}^M}{\sigma_B^M}$$
 In Case 3 CON is fixed at 1.57369
4. Chi-square value (CHI) for BSRV
 Sample size (N) for CSRV
 Not required in Case 3.
 (Fixed values of CHI = 2.9955 or N = 1)
5. Normalized maximum spectrum load (AM = PMSL/PDUL) and static failure load F for Case 2.

For Case 3 these input become AM, FMIN and FMAX where FMIN is the minimum failure load and FMAX is the maximum failure load. The reliability is computed from FMIN to FMAX at an interval of 0.05.

Example runs for cases 2 and 3 are given below.

BSRV

PLEASE INPUT ANALYSIS CASE NUMBER
CASE 1--STATIC RELIABILITY WITY SRV
CASE 2--FATIGUE REL., ULT. STRENGTH WITH SRV
CASE 3--FATIGUE REL., ULT. STRENGTH WITH SRV
CASE 4--FATIGUE REL., LEF APPROACH WITH SRV
CASE 5--FATIGUE REL., LEF APPROACH WITH SRV
CASE 6--FATIGUE REL., RES. STRENGTH WITH SRV
CASE 7--FATIGUE REL., RES. STRENGTH WITH SRV

2

CASE 2, FATIGUE REL. ULT WITH SRV
PLEASE INPUT STATIC ALPHA AND GAMMA
20.0000000 9.735000E-001
PLEASE INPUT SRV ALPHA AND GAMMA
17.0000000 9.693000E-001
PLEASE INPUT SPECTRUM CHARACT. CONST.

PLEASE INPUT CHI SQUARE VALUE
2.9955000
PLEASE INPUT MAX. SPECTRUM LOAD
AND STATIC FAILURE LOAD
9.600000E-001 1.2200000
AT STATIC FAILURE LOAD 1.220
THE ONE LIFETIME FATIGUE REL. IS .0035912

CSRV

PLEASE INPUT ANALYSIS CASE NUMBER
CASE 1--STATIC RELIABILITY WITY SRV
CASE 2--FATIGUE REL., ULT. STRENGTH WITH SRV
CASE 3--FATIGUE REL., ULT. STRENGTH WITH SRV
CASE 4--FATIGUE REL., LEF APPROACH WITH SRV
CASE 5--FATIGUE REL., LEF APPROACH WITH SRV
CASE 6--FATIGUE REL., RES. STRENGTH WITH SRV
CASE 7--FATIGUE REL., RES. STRENGTH WITH SRV

2

CASE 2, FATIGUE REL. ULT WITH SRV
PLEASE INPUT STATIC ALPHA
20.0000000
PLEASE INPUT SRV ALPHA
17.0000000
PLEASE INPUT SPECTRUM CHARACT. CONST.
1.5737000
PLEASE INPUT NUMBER OF SPECIMENS
1
PLEASE INPUT MAX. SPECTRUM LOAD
AND STATIC FAILURE LOAD
9.600000E-001 1.2200000
AT STATIC FAILURE LOAD 1.220
THE ONE LIFETIME FATIGUE REL. IS .0035912

BSRV

PLEASE INPUT ANALYSIS CASE NUMBER

- CASE 1--STATIC RELIABILITY WITH SRV
- CASE 2--FATIGUE REL., ULT. STRENGTH WITH SRV
- CASE 3--FATIGUE REL., ULT. STRENGTH WITH SRV
- CASE 4--FATIGUE REL., LEF APPROACH WITH SRV
- CASE 5--FATIGUE REL., LEF APPROACH WITH SRV
- CASE 6--FATIGUE REL., RES. STRENGTH WITH SRV
- CASE 7--FATIGUE REL., RES. STRENGTH WITH SRV

3

CASE 3, FATIGUE REL. ULT WITH SRV

FIXED CON=1.5736879

STRENGTH ALPHA=20.0, GAMMA=0.9735

SINGLE ARTICLE, CHI=2.9955

REL. COMPUTED AT 0.05 INTERVAL

PLEASE INPUT SRV ALPHA AND GAMMA

17.0000000 9.693000E-001

PLEASE INPUT MAX. SPECTRUM LOAD

MINIMUM AND MAXIMUM STRENGTH

9.600000E-001 1.2000000 1.5000000

AT STATIC FAILURE LOAD	1.200	
THE ONE LIFETIME FATIGUE REL. IS		.0012483
AT STATIC FAILURE LOAD	1.250	
THE ONE LIFETIME FATIGUE REL. IS		.0128437
AT STATIC FAILURE LOAD	1.300	
THE ONE LIFETIME FATIGUE REL. IS		.0579314
AT STATIC FAILURE LOAD	1.350	
THE ONE LIFETIME FATIGUE REL. IS		.1544490
AT STATIC FAILURE LOAD	1.400	
THE ONE LIFETIME FATIGUE REL. IS		.2933223
AT STATIC FAILURE LOAD	1.450	
THE ONE LIFETIME FATIGUE REL. IS		.4467351
AT STATIC FAILURE LOAD	1.500	
THE ONE LIFETIME FATIGUE REL. IS		.5888761

CSRV

PLEASE INPUT ANALYSIS CASE NUMBER

- CASE 1--STATIC RELIABILITY WITH SRV
- CASE 2--FATIGUE REL., ULT. STRENGTH WITH SRV
- CASE 3--FATIGUE REL., ULT. STRENGTH WITH SRV
- CASE 4--FATIGUE REL., LEF APPROACH WITH SRV
- CASE 5--FATIGUE REL., LEF APPROACH WITH SRV
- CASE 6--FATIGUE REL., RES. STRENGTH WITH SRV
- CASE 7--FATIGUE REL., RES. STRENGTH WITH SRV

3

CASE 3, FATIGUE REL. ULT WITH SRV

FIXED CON=1.5736879

STRENGTH ALPHA=20.0, GAMMA=0.9735

SINGLE ARTICLE, CHI=2.9955

REL. COMPUTED AT 0.05 INTERVAL

PLEASE INPUT SRV ALPHA

17.0000000

PLEASE INPUT MAX. SPECTRUM LOAD

MINIMUM AND MAXIMUM STRENGTH

9.600000E-001	1.2000000	1.5000000
AT STATIC FAILURE LOAD	1.200	
THE ONE LIFETIME FATIGUE REL. IS		.0012483
AT STATIC FAILURE LOAD	1.250	
THE ONE LIFETIME FATIGUE REL. IS		.0128437
AT STATIC FAILURE LOAD	1.300	
THE ONE LIFETIME FATIGUE REL. IS		.0579316
AT STATIC FAILURE LOAD	1.350	
THE ONE LIFETIME FATIGUE REL. IS		.1544490
AT STATIC FAILURE LOAD	1.400	
THE ONE LIFETIME FATIGUE REL. IS		.2933227
AT STATIC FAILURE LOAD	1.450	
THE ONE LIFETIME FATIGUE REL. IS		.4467355
AT STATIC FAILURE LOAD	1.500	
THE ONE LIFETIME FATIGUE REL. IS		.5888761

Case 4 and 5: These two cases compute the fatigue reliability at one lifetime using the load enhancement factor approach. Case 4 uses the general input and Case 5 computes the reliability at certain fixed parameters.

1. Gamma value associated with static strength (GAM) for BSRV
Static strength α_s (ALM) for CSRV
Not required for Case 5 ($\alpha_s = 20.0$)
2. Fatigue life α_L and Gamma Value. (AL,GAL) for BSRV
GAL not required for CSRV
For Case 5 AL = 1.25 and GAL = 0.93139
3. Chi-square value (CHI) for BSRV
Sample size (N) for CSRV
For Case 5 N = 3, CHI = 2.09867
4. Fatigue test duration (DN)
For Case 5 DN = 2.0
5. SRV α_{SRV} and Gamma values (ALS,GAS)
GAS not required for CSRV
6. Residual strength α_R
7. Load enhancement factor (PL).

Sample runs for these two cases are given below.

BSRV

PLEASE INPUT ANALYSIS CASE NUMBER
CASE 1--STATIC RELIABILITY WITY SRV
CASE 2--FATIGUE REL., ULT. STRENGTH WITH SRV
CASE 3--FATIGUE REL., ULT. STRENGTH WITH SRV
CASE 4--FATIGUE REL., LEF APPROACH WITH SRV
CASE 5--FATIGUE REL., LEF APPROACH WITH SRV
CASE 6--FATIGUE REL., RES. STRENGTH WITH SRV
CASE 7--FATIGUE REL., RES. STRENGTH WITH SRV

4

CASE 4 FATIGUE REL. LEF WITH SRV
PLEASE INPUT STRENGTH GAMMA
9.735000E-001
PLEASE INPUT LIFE ALPHA AND GAMMA
1.2500000 9.313800E-001
PLEASE INPUT CHI SQUARE VALUE
2.0986700
PLEASE INPUT FATIGUE TEST DURATION
2.0000000
PLEASE INPUT SRV ALPHA AND GAMMA
17.0000000 9.693000E-001
PLEASE INPUT RES. STRENGTH ALPHA
20.0000000
PLEASE INPUT LOAD ENHANCEMENT FACTOR
1.1600000
AT LOAD ENHANCEMENT FACTOR = 1.160
THE ONE LIFETIME REL. IS .8960821

CSRV

PLEASE INPUT ANALYSIS CASE NUMBER
CASE 1--STATIC RELIABILITY WITY SRV
CASE 2--FATIGUE REL., ULT. STRENGTH WITH SRV
CASE 3--FATIGUE REL., ULT. STRENGTH WITH SRV
CASE 4--FATIGUE REL., LEF APPROACH WITH SRV
CASE 5--FATIGUE REL., LEF APPROACH WITH SRV
CASE 6--FATIGUE REL., RES. STRENGTH WITH SRV
CASE 7--FATIGUE REL., RES. STRENGTH WITH SRV

4

CASE 4 FATIGUE REL. LEF WITH SRV
PLEASE INPUT STRENGTH ALPHA
20.0000000
PLEASE INPUT LIFE ALPHA
1.2500000
PLEASE INPUT NUMBER OF SPECIMENS
3
PLEASE INPUT FATIGUE TEST DURATION
2.0000000
PLEASE INPUT SRV ALPHA
17.0000000
PLEASE INPUT RES. STRENGTH ALPHA
20.0000000
PLEASE INPUT LOAD ENHANCEMENT FACTOR
1.1600000
AT LOAD ENHANCEMENT FACTOR = 1.160
THE ONE LIFETIME REL. IS .8960822

BSRV

PLEASE INPUT ANALYSIS CASE NUMBER
 CASE 1--STATIC RELIABILITY WITY SRV
 CASE 2--FATIGUE REL., ULT. STRENGTH WITH SRV
 CASE 3--FATIGUE REL., ULT. STRENGTH WITH SRV
 CASE 4--FATIGUE REL., LEF APPROACH WITH SRV
 CASE 5--FATIGUE REL., LEF APPROACH WITH SRV
 CASE 6--FATIGUE REL., RES. STRENGTH WITH SRV
 CASE 7--FATIGUE REL., RES. STRENGTH WITH SRV

5

CASE 5 FATIGUE REL. LEF WITH SRV
 FIXED STATIC STRENGTH ALPHA =20.0
 FATIGUE LIFE ALPHA = 1.25
 TEST DURATION = 2.0 LIFETIME
 SAMPLE SIZE = 3, CHI=2.09867
 PLEASE INPUT SRV ALPHA AND GAMMA
 17.0000000 9.693000E-001
 PLEASE INPUT RES. STRENGTH ALPHA
 20.0000000
 PLEASE INPUT LOAD ENHANCEMENT FACTOR
 1.1600000
 AT LOAD ENHANCEMENT FACTOR = 1.160
 THE ONE LIFETIME REL. IS .8960821

CSRV

PLEASE INPUT ANALYSIS CASE NUMBER
 CASE 1--STATIC RELIABILITY WITY SRV
 CASE 2--FATIGUE REL., ULT. STRENGTH WITH SRV
 CASE 3--FATIGUE REL., ULT. STRENGTH WITH SRV
 CASE 4--FATIGUE REL., LEF APPROACH WITH SRV
 CASE 5--FATIGUE REL., LEF APPROACH WITH SRV
 CASE 6--FATIGUE REL., RES. STRENGTH WITH SRV
 CASE 7--FATIGUE REL., RES. STRENGTH WITH SRV

5

CASE 5 FATIGUE REL. LEF WITH SRV
 FIXED STATIC STRENGTH ALPHA =20.0
 FATIGUE LIFE ALPHA = 1.25
 TEST DURATION = 2.0 LIFETIME
 SAMPLE SIZE = 3, CHI=2.09867
 PLEASE INPUT SRV ALPHA
 17.0000000
 PLEASE INPUT RES. STRENGTH ALPHA
 20.0000000
 PLEASE INPUT LOAD ENHANCEMENT FACTOR
 1.1600000
 AT LOAD ENHANCEMENT FACTOR = 1.160
 THE ONE LIFETIME REL. IS .8960822

Case 6 and 7: These two cases compute the one lifetime fatigue reliability using the residual strength approach. Case 6 is for general computations and Case 7 is for reliability computations with certain fixed variables. The required input are:

1. Residual strength α_R (ALPR)
Fixed at $\alpha_R = 20.0$ in Case 7.
2. Fatigue life α_L , and associated Gamma value (AL,GAL)
GAL not required for CSRV
Fixed at AL = 1.25 and GAL = 0.93138 in Case 7.
3. Fatigue test duration (AN)
AN = 2.0 in Case 7.
4. Static failure strength (SIGU)
5. Residual strength (SIGR)
6. Maximum applied stress in fatigue test (SIGA)
7. Maximum design spectrum load (PM)
8. SRV α_{SRV} and associated Gamma value (ALS,GAS)
GAS not required for CSRV.
9. Chi-square value (CHI) for BSRV
Sample size (N) for CSRV

Sample runs for Cases 6 and 7 are given below. The program listings follow the sample examples

BSRV
 PLEASE INPUT ANALYSIS CASE NUMBER
 CASE 1--STATIC RELIABILITY WITH SRV
 CASE 2--FATIGUE REL., ULT. STRENGTH WITH SRV
 CASE 3--FATIGUE REL., ULT. STRENGTH WITH SRV
 CASE 4--FATIGUE REL., LEF APPROACH WITH SRV
 CASE 5--FATIGUE REL., LEF APPROACH WITH SRV
 CASE 6--FATIGUE REL., RES. STRENGTH WITH SRV
 CASE 7--FATIGUE REL., RES. STRENGTH WITH SRV

6

CASE 6, FATIGUE REL. RES WITH SRV
 PLEASE INPUT RES. STRENGTH ALPHA
 20.000000
 PLEASE INPUT LIFE ALPHA AND GAMMA
 1.250000 9.313800E-001
 PLEASE INPUT FATIGUE TEST DURATION
 2.000000
 PLEASE INPUT STATIC STRENGTH
 1.250000
 PLEASE INPUT RESIDUAL STRENGTH
 1.180000
 PLEASE INPUT TEST APPLIED STRESS
 9.600000E-001
 PLEASE INPUT MAX. SPECTRUM STRESS
 9.200000E-001
 PLEASE INPUT SRV ALPHA AND GAMMA
 17.000000 9.693000E-001
 PLEASE INPUT CHI SQUARE VALUE
 2.372000
 AT MAX. SPECTRUM STRESS = .920
 THE ONE LIFETIME REL. = .7135201

CSRV

PLEASE INPUT ANALYSIS CASE NUMBER
CASE 1--STATIC RELIABILITY WITH SRV
CASE 2--FATIGUE REL., ULT. STRENGTH WITH SRV
CASE 3--FATIGUE REL., ULT. STRENGTH WITH SRV
CASE 4--FATIGUE REL., LEF APPROACH WITH SRV
CASE 5--FATIGUE REL., LEF APPROACH WITH SRV
CASE 6--FATIGUE REL., RES. STRENGTH WITH SRV
CASE 7--FATIGUE REL., RES. STRENGTH WITH SRV

6

CASE 6, FATIGUE REL. RES WITH SRV

PLEASE INPUT RES. STRENGTH ALPHA

20.000000

PLEASE INPUT LIFE ALPHA

1.250000

PLEASE INPUT FATIGUE TEST DURATION

2.000000

PLEASE INPUT STATIC STRENGTH

1.250000

PLEASE INPUT RESIDUAL STRENGTH

1.180000

PLEASE INPUT TEST APPLIED STRESS

9.600000E-001

PLEASE INPUT MAX. SPECTRUM STRESS

9.200000E-001

PLEASE INPUT SRV ALPHA

17.000000

PLEASE INPUT NUMBER OF SPECIMENS

2

AT MAX. SPECTRUM STRESS = .920

THE ONE LIFETIME REL. = .7135199

BSRV

PLEASE INPUT ANALYSIS CASE NUMBER

CASE 1--STATIC RELIABILITY WITY SRV

CASE 2--FATIGUE REL., ULT. STRENGTH WITH SRV

CASE 3--FATIGUE REL., ULT. STRENGTH WITH SRV

CASE 4--FATIGUE REL., LEF APPROACH WITH SRV

CASE 5--FATIGUE REL., LEF APPROACH WITH SRV

CASE 6--FATIGUE REL., RES. STRENGTH WITH SRV

CASE 7--FATIGUE REL., RES. STRENGTH WITH SRV

7

CASE 7, FATIGUE REL. RES WITH SRV

FIXED RES. STRENGTH ALPHA =20.0

LIFE ALPHA = 1.25

PLEASE INPUT STATIC STRENGTH

1.2500000

PLEASE INPUT RESIDUAL STRENGTH

1.1800000

PLEASE INPUT TEST APPLIED STRESS

9.800000E-001

PLEASE INPUT MAX. SPECTRUM STRESS

9.600000E-001

PLEASE INPUT SRV ALPHA AND GAMMA

17.0000000 9.693000E-001

PLEASE INPUT CHI SQUARE VALUE

2.3720000

AT MAX. SPECTRUM STRESS = .960

THE ONE LIFETIME REL. = .5190697

CSRV

PLEASE INPUT ANALYSIS CASE NUMBER

CASE 1--STATIC RELIABILITY WITY SRV

CASE 2--FATIGUE REL., ULT. STRENGTH WITH SRV

CASE 3--FATIGUE REL., ULT. STRENGTH WITH SRV

CASE 4--FATIGUE REL., LEF APPROACH WITH SRV

CASE 5--FATIGUE REL., LEF APPROACH WITH SRV

CASE 6--FATIGUE REL., RES. STRENGTH WITH SRV

CASE 7--FATIGUE REL., RES. STRENGTH WITH SRV

7

CASE 7, FATIGUE REL. RES WITH SRV

FIXED RES. STRENGTH ALPHA =20.0

LIFE ALPHA = 1.25

PLEASE INPUT STATIC STRENGTH

1.2500000

PLEASE INPUT RESIDUAL STRENGTH

1.1800000

PLEASE INPUT TEST APPLIED STRESS

9.800000E-001

PLEASE INPUT MAX. SPECTRUM STRESS

9.600000E-001

PLEASE INPUT SRV ALPHA

17.0000000

PLEASE INPUT NUMBER OF SPECIMENS

2

AT MAX. SPECTRUM STRESS = .960

THE ONE LIFETIME REL. = .6190694

```

C PROGRAM 'BSRV' STRUCTURAL RELIABILITY COMPUTATIONS--DETAILED INPUT
  DOUBLEPRECISION TEST,PS,SUM,P1,P2,FM,X,DX,DX2,X1,X2,DFI,FME
  SUM = 0.0
  TEST = 0.0000001
  X = 0.0
  DX = 0.001
  DX2 = 0.0005
  AL9 = -ALOG(0.9)
  WRITE(*,101)
101 FORMAT(3X,'PLEASE INPUT ANALYSIS CASE NUMBER',
  A/3X,'CASE 1--STATIC RELIABILITY WITY SRV',
  B/3X,'CASE 2--FATIGUE REL., ULT. STRENGTH WITH SRV',
  C/3X,'CASE 3--FATIGUE REL., ULT. STRENGTH WITH SRV',
  D/3X,'CASE 4--FATIGUE REL., LEF APPROACH WITH SRV',
  E/3X,'CASE 5--FATIGUE REL., LEF APPROACH WITH SRV',
  F/3X,'CASE 6--FATIGUE REL., RES. STRENGTH WITH SRV',
  G/3X,'CASE 7--FATIGUE REL., RES. STRENGTH WITH SRV')
  READ(*,*) ICASE
  K = 0
10 IF(ICASE.EQ.1) GOTO 20
  IF(ICASE.EQ.2.OR.ICASE.EQ.3) GOTO 30
  IF(ICASE.EQ.4.OR.ICASE.EQ.5) GOTO 40
  IF(ICASE.EQ.6.OR.ICASE.EQ.7) GOTO 50
20 IF(K.NE.0) GOTO 21
  WRITE(*,1)
  WRITE(*,102)
  READ(*,*) ALM
  WRITE(*,103)
  READ(*,*) ALS
  WRITE(*,104)
  READ(*,*) GAS
  WRITE(*,105)
  READ(*,*) BET
  WRITE(*,106)
  READ(*,*) AK
102 FORMAT(3X,'PLEASE INPUT STATIC STRENGTH ALPHA')
103 FORMAT(3X,'PLEASE INPUT SRV ALPHA')
104 FORMAT(3X,'PLEASE INPUT SRV GAMMA')
105 FORMAT(3X,'PLEASE INPUT LOWER STRENGTH BETA')
106 FORMAT(3X,'PLEASE INPUT LOAD LEVEL')
  AT = AK/GAS
  DELTX = 1.0
  IF(BET.GE.2.0) DELTX=2.0
  IF(AK.GE.2.0) DELTX=2.0
  GOTO 90
21 WRITE(*,201) AK,SUM
  1 FORMAT(3X,'CASE 1,STATIC REL. WITH SRV')
201 FORMAT(3X,'AT LOAD LEVEL OF',F8.3,
  +/3X,'THE STRUCTURAL RELIABILITY IS',F10.7)
  GOTO 99
30 IF(K.NE.0) GOTO 31
  DELTX = 2.0
  IF(ICASE.EQ.3) GOTO 35
  WRITE(*,3)
  WRITE(*,107)

```

```

READ(*,*) ALM,GAM
WRITE(*,108)
READ(*,*) ALS,GAS
WRITE(*,109)
READ(*,*) CON
WRITE(*,110)
READ(*,*) CHI
WRITE(*,111)
READ(*,*) AM,F
107 FORMAT(3X,'PLEASE INPUT STATIC ALPHA AND GAMMA')
108 FORMAT(3X,'PLEASE INPUT SRV ALPHA AND GAMMA')
109 FORMAT(3X,'PLEASE INPUT SPECTRUM CHARACT. CONST. ')
110 FORMAT(3X,'PLEASE INPUT CHI SQUARE VALUE')
111 FORMAT(3X,'PLEASE INPUT MAX. SPECTRUM LOAD',
+ /5X,'AND STATIC FAILURE LOAD')
GOTO 36
35 WRITE(*,4)
DFI = 0.05
CON = 1.5736879
CHI = 2.9955
ALM = 20.0
GAM = 0.9735
WRITE(*,108)
READ(*,*) ALS,GAS
WRITE(*,112)
READ(*,*) AM,FMIN,FMAX
112 FORMAT(3X,'PLEASE INPUT MAX. SPECTRUM LOAD',
+ /3X,'MINIMUM AND MAXIMUM STRENGTH')
F = FMIN
36 F1 = AM*CON
FX = ((ALM/CHI)**(1.0/ALM))*F1/GAM
32 FG = F/GAS
AT = FG/(CHI**(1.0/ALS))
GOTO 90
31 WRITE(*,202) F,SUM
202 FORMAT(3X,'AT STATIC FAILURE LOAD ',F8.3,
+ /3X,'THE ONE LIFETIME FATIGUE REL. IS',F10.7)
3 FORMAT(3X,'CASE 2, FATIGUE REL. ULT WITH SRV')
4 FORMAT(3X,'CASE 3, FATIGUE REL. ULT WITH SRV',
+ /3X,'FIXED CON=1.5736879',
+ /3X,'STRENGTH ALPHA=20.0, GAMMA=0.9735',
+ /3X,'SINGLE ARTICLE, CHI=2.9955',
+ /3X,'REL. COMPUTED AT 0.05 INTERVAL')
IF(ICASE.EQ.2) GOTO 99
F = F+DFI
X = 0.0
SUM = 0.0
IF(F.LT.FMAX) GOTO 32
GOTO 99
40 IF(K.NE.0) GOTO 41
DELT X = 2.0
IF(ICASE.EQ.5) GOTO 45
WRITE(*,5)
WRITE(*,113)
READ(*,*) GAM

```

```

WRITE(*,114)
READ(*,*) AL,GAL
WRITE(*,115)
READ(*,*) CHI
WRITE(*,116)
READ(*,*) DN
113 FORMAT(3X,'PLEASE INPUT STRENGTH GAMMA')
114 FORMAT(3X,'PLEASE INPUT LIFE ALPHA AND GAMMA')
115 FORMAT(3X,'PLEASE INPUT CHI SQUARE VALUE')
116 FORMAT(3X,'PLEASE INPUT FATIGUE TEST DURATION')
GOTO 46
45 WRITE(*,6)
GAM = 0.9735
GAL = 0.93138
CHI = 2.09867
DN = 2.0
AL = 1.25
46 WRITE(*,117)
READ(*,*) ALS,GAS
WRITE(*,118)
READ(*,*) ALPR
WRITE(*,119)
READ(*,*) PL
117 FORMAT(3X,'PLEASE INPUT SRV ALPHA AND GAMMA')
118 FORMAT(3X,'PLEASE INPUT RES. STRENGTH ALPHA')
119 FORMAT(3X,'PLEASE INPUT LOAD ENHANCEMENT FACTOR')
ARG = CHI*((GAL/DN)**AL)
AT = PL/GAS
GOTO 90
41 WRITE(*,203) PL,SUM
203 FORMAT(3X,'AT LOAD ENHANCEMENT FACTOR = ',F8.3,
+/3X,'THE ONE LIFETIME REL. IS ',F10.7)
5 FORMAT(3X,'CASE 4 FATIGUE REL. LEF WITH SRV')
6 FORMAT(3X,'CASE 5 FATIGUE REL. LEF WITH SRV',
+/3X,'FIXED STATIC STRENGTH ALPHA =20.0',
+/3X,'FATIGUE LIFE ALPHA = 1.25',
+/3X,'TEST DURATION = 2.0 LIFETIME',
+/3X,'SAMPLE SIZE = 3, CHI=2.09867')
GOTO 99
50 IF(K.NE.0) GOTO 51
DELTX = 1.0
X = 0.05-DX2
IF(ICASE.EQ.7) GOTO 55
WRITE(*,7)
WRITE(*,120)
READ(*,*) ALPR
WRITE(*,121)
READ(*,*) AL,GAL
WRITE(*,122)
READ(*,*) AN
120 FORMAT(3X,'PLEASE INPUT RES. STRENGTH ALPHA')
121 FORMAT(3X,'PLEASE INPUT LIFE ALPHA AND GAMMA')
122 FORMAT(3X,'PLEASE INPUT FATIGUE TEST DURATION')
GOTO 56
55 WRITE(*,8)

```

```

ALPR = 20.0
AL = 1.25
GAL = 0.93138
AN = 2.0
56 WRITE(*,123)
  READ(*,*) SIGU
  WRITE(*,124)
  READ(*,*) SIGR
  WRITE(*,125)
  READ(*,*) SIGA
  WRITE(*,126)
  READ(*,*) PM
  WRITE(*,127)
  READ(*,*) ALS,GAS
  WRITE(*,128)
  READ(*,*) CHI
123 FORMAT(3X,'PLEASE INPUT STATIC STRENGTH')
124 FORMAT(3X,'PLEASE INPUT RESIDUAL STRENGTH')
125 FORMAT(3X,'PLEASE INPUT TEST APPLIED STRESS')
126 FORMAT(3X,'PLEASE INPUT MAX. SPECTRUM STRESS')
127 FORMAT(3X,'PLEASE INPUT SRV ALPHA AND GAMMA')
128 FORMAT(3X,'PLEASE INPUT CHI SQUARE VALUE')
  CH = CHI**(1.0/AL)
  S1 = ALPR/AL
  C = ((SIGU/SIGA)**S1-(SIGR/SIGA)**S1)/AN
  AT = PM/GAS
  IF(SIGU.LT.DELTX) DELTX = 0.9*SIGU
  GOTO 90
51 WRITE(*,204) PM,SUM
204 FORMAT(3X,'AT MAX. SPECTRUM STRESS = ',F8.3,
  +/3X,'THE ONE LIFETIME REL. = ',F10.7)
7 FORMAT(3X,'CASE 6, FATIGUE REL. RES WITH SRV')
8 FORMAT(3X,'CASE 7, FATIGUE REL. RES WITH SRV',
  +/3X,'FIXED RES. STRENGTH ALPHA =20.0',
  +/3X,'LIFE ALPHA = 1.25')
  GOTO 99
90 X = X+DX
  X1 = X-DX2
  X2 = X+DX2
  P1 = EXP(-(X1/AT)**ALS)
  P2 = EXP(-(X2/AT)**ALS)
  IF(ICASE.EQ.2.OR.ICASE.EQ.3) GOTO 91
  IF(ICASE.EQ.4.OR.ICASE.EQ.5) GOTO 92
  IF(ICASE.EQ.6.OR.ICASE.EQ.7) GOTO 93
  FME = (X/BET)**ALM
  IF(FME.GT.40.) GOTO 190
  FM = EXP(-FME)
  GOTO 95
190 FM = 0.0
  GOTO 95
91 FME = ((FX*GAM/X)**ALM)*CHI
  IF(FME.GT.40.) GOTO 191
  FM = EXP(-FME)
  GOTO 95
191 FM = 0.0

```

```
GOTO 95
92 FME = ARG/(X**ALPR)
   IF(FME.GT.40.) GOTO 192
   FM = EXP(-FME)
   GOTO 95
192 FM = 0.0
   GOTO 95
93 F = ((SIGU/X)**S1-1.0)/C
   BN = F/GAL
   BU = BN/CH
   FME = (1.0/BU)**AL
   IF(FME.GT.40.) GOTO 193
   FM = EXP(-FME)
   GOTO 95
193 FM = 0.0
95 PS = FM*(P1-P2)
   SUM = SUM+PS
   IF(X.LE.DELTX) GOTO 90
   IF(PS.GT.TEST) GOTO 90
   K = K+1
   GOTO 10
99 STOP
   END
```

```

C PROGRAM 'CSRV' STRUCTURAL RELIABILITY COMPUTATIONS--SHORT INPUT
  DOUBLEPRECISION TEST,PS,SUM,P1,P2,FM,X,DX,DX2,X1,X2,DFI,FME
  COMMON/GMA/B(101),Y(101)
  COMMON/CHI/CHL(15)
  OPEN(5,FILE='PSI.DAT')
  READ(5,*) (B(I),I=1,101)
  READ(5,*) (Y(I),I=1,101)
  READ(5,*) (CHL(I),I=1,15)
  SUM = 0.0
  TEST = 0.0000001
  X = 0.0
  DX = 0.001
  DX2 = 0.0005
  AL9 = -ALOG(0.9)
  WRITE(*,101)
101 FORMAT(3X,'PLEASE INPUT ANALYSIS CASE NUMBER',
  A/3X,'CASE 1--STATIC RELIABILITY WITH SRV',
  B/3X,'CASE 2--FATIGUE REL., ULT. STRENGTH WITH SRV',
  C/3X,'CASE 3--FATIGUE REL., ULT. STRENGTH WITH SRV',
  D/3X,'CASE 4--FATIGUE REL., LEF APPROACH WITH SRV',
  E/3X,'CASE 5--FATIGUE REL., LEF APPROACH WITH SRV',
  F/3X,'CASE 6--FATIGUE REL., RES. STRENGTH WITH SRV',
  G/3X,'CASE 7--FATIGUE REL., RES. STRENGTH WITH SRV')
  READ(*,*) ICASE
  K = 0
10 IF(ICASE.EQ.1) GOTO 20
  IF(ICASE.EQ.2.OR.ICASE.EQ.3) GOTO 30
  IF(ICASE.EQ.4.OR.ICASE.EQ.5) GOTO 40
  IF(ICASE.EQ.6.OR.ICASE.EQ.7) GOTO 50
20 IF(K.NE.0) GOTO 21
  WRITE(*,1)
  WRITE(*,102)
  READ(*,*) ALM
  WRITE(*,103)
  READ(*,*) ALS
  WRITE(*,104)
  READ(*,*) N
  WRITE(*,105)
  READ(*,*) XB
  WRITE(*,106)
  READ(*,*) AK
102 FORMAT(3X,'PLEASE INPUT STATIC STRENGTH ALPHA')
103 FORMAT(3X,'PLEASE INPUT SRV ALPHA')
104 FORMAT(3X,'PLEASE INPUT NUMBER OF SPECIMENS')
105 FORMAT(3X,'PLEASE INPUT MEAN STATIC STRENGTH ')
106 FORMAT(3X,'PLEASE INPUT LOAD LEVEL')
  ARG = 1.0+1.0/ALM
  GAM = GAMMA(ARG)
  CHI = CHIS(N)
  BET = XB/GAM
  BET = BET/(CHI**(1.0/ALM))
  ARG = 1.0+1.0/ALS
  GAS = GAMMA(ARG)
  AT = AK/GAS
  DELTX = 1.0

```

```

IF(BET.GE.2.0) DELTX = 2.0
IF(AK.GE.2.0) DELTX = 2.0
GOTO 90
21 WRITE(*,201) AK,SUM
  1 FORMAT(3X,'CASE 1,STATIC REL. WITH SRV')
201 FORMAT(3X,'AT LOAD LEVEL OF',F8.3,
  +/3X,'THE STRUCTURAL RELIABILITY IS',F10.7)
GOTO 99
30 IF(K.NE.0) GOTO 31
  DELTX = 2.0
  IF(ICASE.EQ.3) GOTO 35
  WRITE(*,3)
  WRITE(*,107)
  READ(*,*) ALM
  WRITE(*,108)
  READ(*,*) ALS
  WRITE(*,109)
  READ(*,*) CON
  WRITE(*,110)
  READ(*,*) N
  WRITE(*,111)
  READ(*,*) AM,F
107 FORMAT(3X,'PLEASE INPUT STATIC ALPHA')
108 FORMAT(3X,'PLEASE INPUT SRV ALPHA')
109 FORMAT(3X,'PLEASE INPUT SPECTRUM CHARACT. CONST. ')
110 FORMAT(3X,'PLEASE INPUT NUMBER OF SPECIMENS')
111 FORMAT(3X,'PLEASE INPUT MAX. SPECTRUM LOAD',
  +/5X,'AND STATIC FAILURE LOAD')
  CHI = CHIS(N)
  ARG = 1.0+1.0/ALM
  GAM = GAMMA(ARG)
  ARG = 1.0+1.0/ALS
  GAS = GAMMA(ARG)
  GOTO 36
35 WRITE(*,4)
  DFI = 0.05
  CON = 1.5736879
  CHI = 2.9955
  ALM = 20.0
  GAM = 0.9735
  WRITE(*,108)
  READ(*,*) ALS
  WRITE(*,112)
  READ(*,*) AM,FMIN,FMAX
112 FORMAT(3X,'PLEASE INPUT MAX. SPECTRUM LOAD',
  +/3X,'MINIMUM AND MAXIMUM STRENGTH')
  ARG = 1.0+1.0/ALS
  GAS = GAMMA(ARG)
  F = FMIN
36 F1 = AM*CON
  FX = ((AL9/CHI)**(1.0/ALM))*F1/GAM
32 FG = F/GAS
  AT = FG/(CHI**(1.0/ALS))
  GOTO 90
31 WRITE(*,202) F,SUM

```

```

202 FORMAT(3X,'AT STATIC FAILURE LOAD ',F8.3,
+/3X,'THE ONE LIFETIME FATIGUE REL. IS',F10.7)
3  FORMAT(3X,'CASE 2, FATIGUE REL. ULT WITH SRV')
4  FORMAT(3X,'CASE 3, FATIGUE REL. ULT WITH SRV',
+/3X,'FIXED CON=1.5736879',
+/3X,'STRENGTH ALPHA=20.0, GAMMA=0.9735',
+/3X,'SINGLE ARTICLE, CHI=2.9955',
+/3X,'REL. COMPUTED AT 0.05 INTERVAL')
  IF(ICASE.EQ.2) GOTO 99
  F = F+DFI
  X =0.0
  SUM = 0.0
  IF(F.LT.FMAX) GOTO 32
  GOTO 99
40 IF(K.NE.0) GOTO 41
  DELTX = 2.0
  IF(ICASE.EQ.5) GOTO 45
  WRITE(*,5)
  WRITE(*,113)
  READ(*,*) ALM
  WRITE(*,114)
  READ(*,*) AL
  WRITE(*,115)
  READ(*,*) N
  WRITE(*,116)
  READ(*,*) DN
113 FORMAT(3X,'PLEASE INPUT STRENGTH ALPHA')
114 FORMAT(3X,'PLEASE INPUT LIFE ALPHA')
115 FORMAT(3X,'PLEASE INPUT NUMBER OF SPECIMENS')
116 FORMAT(3X,'PLEASE INPUT FATIGUE TEST DURATION')
  ARG = 1.0+1.0/ALM
  GAM = GAMMA(ARG)
  ARG = 1.0+1.0/AL
  GAL = GAMMA(ARG)
  CHI = CHIS(N)
  GOTC 46
45 WRITE(*,6)
  GAM = 0.9735
  GAL = 0.93138
  CHI = 2.09867
  DN = 2.0
  AL = 1.25
46 WRITE(*,117)
  READ(*,*) ALS
  WRITE(*,118)
  READ(*,*) ALPR
  WRITE(*,119)
  READ(*,*) PL
117 FORMAT(3X,'PLEASE INPUT SRV ALPHA')
118 FORMAT(3X,'PLEASE INPUT RES. STRENGTH ALPHA')
119 FORMAT(3X,'PLEASE INPUT LOAD ENHANCEMENT FACTOR')
  ARG = 1.0+1.0/ALS
  GAS = GAMMA(ARG)
  ARG = CHI*((GAL/DN)**AL)
  AT = PL/GAS

```

```

GOTO 90
41 WRITE(*,203) PL,SUM
203 FORMAT(3X,'AT LOAD ENHANCEMENT FACTOR = ',F8.3,
+/3X,'THE ONE LIFETIME REL. IS ',F10.7)
5 FORMAT(3X,'CASE 4 FATIGUE REL. LEF WITH SRV')
6 FORMAT(3X,'CASE 5 FATIGUE REL. LEF WITH SRV',
+/3X,'FIXED STATIC STRENGTH ALPHA =20.0',
+/3X,'FATIGUE LIFE ALPHA = 1.25',
+/3X,'TEST DURATION = 2.0 LIFETIME',
+/3X,'SAMPLE SIZE = 3, CHI=2.09867')
GOTO 99
50 IF(K.NE.0) GOTO 51
DELTX = 1.0
X = 0.05-DX2
IF(ICASE.EQ.7) GOTO 55
WRITE(*,7)
WRITE(*,120)
READ(*,*) ALPR
WRITE(*,121)
READ(*,*) AL
WRITE(*,122)
READ(*,*) AN
120 FORMAT(3X,'PLEASE INPUT RES. STRENGTH ALPHA')
121 FORMAT(3X,'PLEASE INPUT LIFE ALPHA')
122 FORMAT(3X,'PLEASE INPUT GATIGUE TEST DURATION')
ARG = 1.0+1.0/AL
GAL = GAMMA(ARG)
GOTO 56
55 WRITE(*,8)
ALPR = 20.0
AL = 1.25
GAL = 0.93138
AN = 2.0
56 WRITE(*,123)
READ(*,*) SIGU
WRITE(*,124)
READ(*,*) SIGR
WRITE(*,125)
READ(*,*) SIGA
WRITE(*,126)
READ(*,*) PM
WRITE(*,127)
READ(*,*) ALS
WRITE(*,128)
READ(*,*) N
123 FORMAT(3X,'PLEASE INPUT STATIC STRENGTH')
124 FORMAT(3X,'PLEASE INPUT RESIDUAL STRENGTH')
125 FORMAT(3X,'PLEASE INPUT TEST APPLIED STRESS')
126 FORMAT(3X,'PLEASE INPUT MAX. SPECTRUM STRESS')
127 FORMAT(3X,'PLEASE INPUT SRV ALPHA')
128 FORMAT(3X,'PLEASE INPUT NUMBER OF SPECIMENS')
ARG = 1.0+1.0/ALS
GAS = GAMMA(ARG)
CHI = CHIS(N)
CH = CHI**(1.0/AL)

```

```

S1 = ALPR/AL
C = ((SIGU/SIGA)**S1-(SIGR/SIGA)**S1)/AN
AT = PM/GAS
IF(SIGU.LT.DELTX) DELTX = 0.9*SIGU
GOTO 90
51 WRITE(*,204) PM,SUM
204 FORMAT(3X,'AT MAX. SPECTRUM STRESS =',F8.3,
+/3X,'THE ONE LIFETIME REL. = ',F10.7)
7 FORMAT(3X,'CASE 6, FATIGUE REL. RES WITH SRV')
8 FORMAT(3X,'CASE 7, FATIGUE REL. RES WITH SRV',
+/3X,'FIXED RES. STRENGTH ALPHA =20.0',
+/3X,'LIFE ALPHA = 1.25')
GOTO 99
90 X = X+DX
X1 = X-DX2
X2 = X+DX2
P1 = EXP(-(X1/AT)**ALS)
P2 = EXP(-(X2/AT)**ALS)
IF(ICASE.EQ.2.OR.ICASE.EQ.3) GOTO 91
IF(ICASE.EQ.4.OR.ICASE.EQ.5) GOTO 92
IF(ICASE.EQ.6.OR.ICASE.EQ.7) GOTO 93
FME = (X/BET)**ALM
IF(FME.GT.40.) GOTO190
FM = EXP(-FME)
GOTO 95
190 FM = 0.0
GOTO 95
91 FME = ((FX*GAM/X)**ALM)*CHI
IF(FME.GT.40.) GOTO 191
FM = EXP(-FME)
GOTO 95
191 FM = 0.0
GOTO 95
92 FME = ARG/(X**ALPR)
IF(FME.GT.40.) GOTO 192
FM = EXP(-FME)
GOTO 95
192 FM = 0.0
GOTO 95
93 F = ((SIGU/X)**S1-1.0)/C
BN = F/GAL
BU = BN/CH
FME = (1.0/BU)**AL
IF(FME.GT.40.) GOTO 193
FM = EXP(-FME)
GOTO 95
193 FM = 0.0
95 PS = FM*(P1-P2)
SUM = SUM+PS
IF(X.LE.DELTX) GOTO 90
IF(PS.GT.TEST) GOTO 90
K = K+1
GOTO 10
99 STOP
END

```

```

FUNCTION CHIS(N)
COMMON/CHI/CHL(15)
AN = N
BN = 2.0*AN
IF(N.GE.15) GOTO 50
CHIS = CHL(N)
GOTO 60
50 B = 1.0/(9.0*AN)
CL = 1.0-B+1.645*SQRT(B)
CHIS = CL*CL*CL
60 CONTINUE
RETURN
END
FUNCTION GAMMA(X)
COMMON/GMA/B(101),Y(101)
ARG = X
A = 1.0
IF(ARG.LT.1.0) GOTO 10
IF(ARG.EQ.1.0) GOTO 110
IF(ARG.EQ.2.0) GOTO 110
IF(ARG.GT.2.0) GOTO 20
GOTO 30
10 A = A/ARG
ARG = ARG+1.0
IF(ARG.LT.1.0) GOTO 10
IF(ARG.EQ.1.0) GOTO 110
GOTO 30
20 ARG = ARG-1.0
A = A*ARG
IF(ARG.GT.2.0) GOTO 20
IF(ARG.EQ.2.0) GOTO 110
30 DO 40 I=1,101
IF(B(I).GT.ARG) GOTO 50
40 CONTINUE
50 SLOP = (Y(I)-Y(I-1))/(B(I)-B(I-1))
F = Y(I-1)+(ARG-B(I-1))*SLOP
GOTO 60
110 F = 1.0
60 GAMMA = F*A
RETURN
END

```

PSI.DAT TAB VALUES OF CHI-SQUARE AND GAMMA FUNCTIONS

```

1.0, 1.01, 1.02, 1.03, 1.04, 1.05, 1.06, 1.07, 1.08, 1.09, 1.1, 1.11,
1.12, 1.13, 1.14, 1.15, 1.16, 1.17, 1.18, 1.19, 1.2, 1.21, 1.22, 1.23,
1.24, 1.25, 1.26, 1.27, 1.28, 1.29, 1.3, 1.31, 1.32, 1.33, 1.34, 1.35,
1.36, 1.37, 1.38, 1.39, 1.4, 1.41, 1.42, 1.43, 1.44, 1.45, 1.46, 1.47,
1.48, 1.49, 1.5, 1.51, 1.52, 1.53, 1.54, 1.55, 1.56, 1.57, 1.58, 1.59,
1.6, 1.61, 1.62, 1.63, 1.64, 1.65, 1.66, 1.67, 1.68, 1.69, 1.7, 1.71,
1.72, 1.73, 1.74, 1.75, 1.76, 1.77, 1.78, 1.79, 1.8, 1.81, 1.82, 1.83,
1.84, 1.85, 1.86, 1.87, 1.88, 1.89, 1.9, 1.91, 1.92, 1.93, 1.94, 1.95,
1.96, 1.97, 1.98, 1.99, 2.,
1., .99433, .98884, .98355, .97844, .9735, .96874, .96415, .95973,
2.9955, 2.372, 2.09867, 1.93838, 1.8307, 1.75217, 1.69179, 1.6435,
1.60383, 1.5705, 1.542, 1.51729, 1.49558, 1.47632, 1.4591

```

DISTRIBUTION LISTGOVERNMENT ACTIVITIES (continued)

	<u>NO. OF COPIES</u>
NAVSHIPRANDCEN, Annapolis, MD 21402 (Attn: H. Edelstein, Code 2870).	1
NRL, Washington, D.C. 20375 (Attn: Dr. I. Wolock, Code 6122; Dr. C. I. Chang) and Dr. R. Badaliance).	3
NSWC, WHITE OAK LABORATORY, Silver Spring, MD 20910 (Attn: Dr. J. Goff, Materials Evaluation Branch, Code R-34).	1
(Attn: Dr. J. M. Augl).	1
ONR, 800 N. Quincy Street, Arlington, VA 22217 (Attn: A. Kushner, Code 432/A; Y. Rajapakse, Code 1132SM).	2
ONT, 800 N. Quincy Street, Arlington, VA 22217 (Attn: Cdr. D. Brown, OCNR-212).	1
PLASTEC, Picatinny Arsenal, Dover, NJ 07801 (Attn: H. Pebly).	1
(Attn: Librarian, Code DRDAR-SCM-0, Bldg. 351-N).	1
ARMY MATERIALS TECHNOLOGY LABORATORY, Watertown, MA 02172-0001. (Attn: D. Oplinger, SLCMT-MS).	1
U. S. ARMY APPLIED TECHNOLOGY LABORATORY, USARTL, (AVRADCOM), Ft. Eustis, VA 23604 (Attn: J. Waller; T. Mazza).	2
U. S. ARMY AIR MOBILITY R&D LABORATORY, Ft. Eustis, VA 23604 (Attn: H. Reddick).	1
U. S. ARMY R&T LABORATORY (AVRADCOM), Ames Research Center, Moffet Field, CA 94035 (Attn: F. Immen, DAVDL-AS-MS 207-5).	1
U. S. NAVAL ACADEMY, Annapolis, MD 21402 (Attn: Dr. R. D. Jamison, Mechanical Engineering Department)	1
DAVID TAYLOR NAVAL SHIP RESEARCH & DEVELOPMENT CENTER, Annapolis, MD 21402 (Attn: E. T. Camponeschi, Code 2844; R. Crane, Code 2844).	2
DAVID TAYLOR NAVAL SHIP R&D CENTER Bethesda, MD 20084 (Attn: A. Macander, Code 1720).	1
NAVAIRDEVCEN, Warminster, PA 18974 (Attn: Code 8131).	3
(Attn: Code 09L2).	2

DISTRIBUTION LIST

GOVERNMENT ACTIVITIES

	<u>NO. OF COPIES</u>
AFWAL, WPAFB, OH 45433	
(Attn: FIBEC, Dr. G. Sendeckyj).	1
(Attn: FIB/L. Kelly, W. Goesch, C. Ramsey).	3
(Attn: FIBCA).	1
(Attn: FIBE/Mr. D. Smith).	1
(Attn: MLBM/Dr. J. Whitney, M. Knight).	2
(Attn: MLB/F. Cherry).	1
(Attn: MBC/Reinhart).	1
(Attn: AFWAL/MLSE/S. Fecheck).	1
DEPARTMENT OF THE AIR FORCE, Bldg. 410, Bolling Air Force Base, Washington, D.C. 20332	
(Attn: Dr. M. Salkind, Dr. Amos).	2
DEFENSE TECHNICAL INFORMATION CENTER (DTIC), Bldg. #5, Cameron Station, Alexandria, VA 22314	
(Attn: Administrator).	2
FAA, Washington, D.C. 20591	
(Attn: J. R. Soderquist, AW 103).	1
FAA, Technical Center, Atlantic City, NJ 08405	
(Attn: L. Neri, Code ACT-330; M. Caiafa, Code ACT-330).	2
NASA Headquarters, Washington, D.C. 20546	
(Attn: Airframes Branch, FS-120).	1
(Attn: OAST/RM Dr. D. Mulville).	1
NASA, George C. Marshall Space Flight Center, Huntsville, AL 35812	
(Attn: E. E. Engler, S&E-ASTN-ES).	1
(Attn: R. Schwinghamer, S&E-ASTN-M).	1
NASA, Langley Research Center, Hampton, VA 23365	
(Attn: Dr. J. R. Davidson, MS 188E; Dr. J. Starnes, MS 190; Dr. M. Mikulus, H. Bohan, and Dr. C. P. Blakenship, MS 189M).	5
NASA, Lewis Research Center, Cleveland, OH 44135	
(Attn: Dr. C. Chamis, MS 49-6; M. Hershberg, MS 49-6).	2
NAVAIRSYSCOM, Washington, D.C. 20361	
(Attn: AIR-00D4).	1
(Attn: AIR-530).	1
(Attn: AIR-5302D).	1
(Attn: AIR-5302).	1
(Attn: AIR-5302F).	1
(Attn: AIR-53032D).	1
(Attn: AIR-931B).	1
NAVPGSCHL, Monterey, CA 95940	
(Attn: Prof. R. Ball, Prof. M. H. Bank, Prof. K. Challenger)	3
NAVSEASYSYSCOM, Washington, D.C. 20360	
(Attn: C. Zannis, Sea 05R25).	1
NAVSEC, Arlington, VA 20360	
(Attn: NSEC-6101E).	1

DISTRIBUTION LISTNON-GOVERNMENT ACTIVITIES (continued)

	<u>NO. OF COPIES</u>
MCDONNELL-DOUGLAS CORP., St. Louis, MO 63166 (Attn: K. Stenberg, R. Garrett, R. Riley, J. Doerr).	4
MCDONNELL-DOUGLAS CORP., Long Beach, CA 90846 (Attn: J. Palmer).	1
MCDONNELL-DOUGLAS HELICOPTER CO., Culver City, CA 90230 (Attn: J. K. Sen, Trailer 2002).	1
NORTHROP AIRCRAFT CORP., One Northrop Ave., Hawthorne, CA 90250 (Attn: Dr. M. Ratwani, B. Butler and R. Whitehead)).	1
ROCKWELL INTERNATIONAL, Columbus, OH 43216 (Attn: M. Schweiger).	1
ROCKWELL INTERNATIONAL, Los Angeles, CA 90009 (Attn: Dr. Lackman).	1
(Attn: W. O'Brien).	1
ROCKWELL INTERNATIONAL, Tulsa, OK 74151 (Attn: F. Kaufman).	1
SIKORSKY AIRCRAFT, Stratford, CT 06622 (Attn: S. Garbo).	1
TELEDYNE RYAN AERONAUTICAL CO., San Diego, CA 92138 (Attn: R. Long).	1

DISTRIBUTION LIST
NON-GOVERNMENT ACTIVITIES

	<u>NO. OF COPIES</u>
ALCOA DEFENSE SYSTEMS CORP., 16761 Via delCampo Court, San Diego, CA 92127 (Attn: D. Myers).	1
AVCO, Specialty Materials Div., 2 Industrial Avenue, Lowell, MA 01851 (Attn: William F. Grant).	1
BEECH AIRCRAFT CORP., 4130 Linden Avenue, Dayton OH 45432 (Attn: M. B. Goetz).	1
BELL HELICOPTER CO., Fort Worth, TX 76101 (Attn: M. K. Stevenson).	1
BOEING CO., P.O. Box 3707, Seattle, WA 98124 (Attn: J. McCarty, J. Quinliven, and Dr. R. June).	3
BOEING CO., Vertol Division, P. O. Box 16858, Philadelphia, PA 19142 (Attn: R. L. Pinckney).	1
	1
	1
BOEING CO., Wichita, KS 67277-7730 (Attn: J. Avery).	1
(Attn: R. Waner).	1
DEPARTMENT OF TRANSPORTATION, Kendall Square, Cambridge, MA 02142 (Attn: Dr. Ping Tong, DTS 76, TSC).	1
GENERAL DYNAMICS/CONVAIR, San Diego, CA 92138 (Attn: D. R. Dunbar).	1
GENERAL DYNAMICS, Fort Worth Division, P.O. Box 748, Fort Worth, TX 76101 (Attn: J. A. Fant).	1
(Attn: Composite Structures Eng. Dept.)	1
GENERAL ELECTRIC CO., Philadelphia, PA 19101 (Attn: A. Garber, C. Zweben).	2
GRUMMAN CORPORATION, South Oyster Bay Rd., Bethpage, NY 11714 (Attn: R. Hadcock).	1
(Attn: S. Dastin).	1
LOCKHEED-CALIFORNIA CO., Burbank, CA 91510 (Attn: E. K. Walker).	1
(Attn: A. Vaughn).	1
(Attn: A. James).	1
LOCKHEED-MISSILE & SPACE CO., 1111 Lockheed Way, Sunnyvale, CA 94086 (Attn: J. A. Bailie).	1
LOCKHEED-CALIFORNIA CO., Rye Canyon Research Laboratory, Burbank, CA 91520 (Attn: D. E. Pettit).	1
LTV AEROSPACE & DEFENSE CO., Vought Missile & Advanced Program Div., P.O. Box 225907, Dallas, TX 75265-0003 (Attn: R. Knight).	1



DEPARTMENT OF THE NAVY
NAVAL AIR WARFARE CENTER
AIRCRAFT DIVISION

5510
874000R74/Ser 10016
24 May 96

B112 288 & B112 326

From: Commanding Officer, Naval Air Warfare Center
Aircraft Division Warminster

Subj: CHANGE OF DISTRIBUTION STATEMENT

Ref: (a) NADC Report No. NADC-87042-60, Volumes I and II
Subj: Certification Testing Methodology for Composite Structures

1. With the concurrence of the FAA Technical Center, Atlantic City, N.J., the other agency for which reference (a) was prepared, the distribution statement for the report is changed to: Distribution Statement A - Distribution Unlimited - Approved for Public Release.

BRUCE H. HEATH, JR.

By direction

Distribution:
List attached

B112 288 & B112 326

Completed
1-10-00
BWW