

UNCLASSIFIED

AD NUMBER

ADB132927

LIMITATION CHANGES

TO:

Approved for public release; distribution is unlimited.

FROM:

Distribution authorized to U.S. Gov't. agencies and their contractors; Critical Technology; 23 JAN 1989. Other requests shall be referred to Defense Threat Reduction Agency, 8725 Kingman Road, Fort Belvoir, VA 22060. This document contains export-controlled technical data.

AUTHORITY

DTRA/SCC-WMD Form 58 dtd 19 Jun 2013

THIS PAGE IS UNCLASSIFIED

DNA 6325F

OPERATIONS ANVIL, CRESSET, TINDERBOX, AND GUARDIAN

EVENTS HUSKY PUP, MIGHTY EPIC, HYBLA GOLD, DIABLO HAWK, HURON KING, and MINERS IRON

24 October 1975 - 31 October 1980

Approved for public release;
distribution is unlimited.

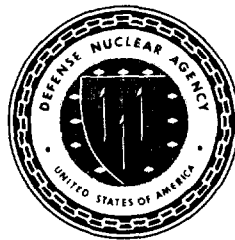
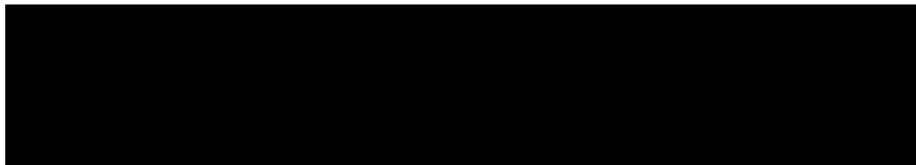

**United States Underground Nuclear Weapons Tests
Underground Nuclear Test Personnel Review**

Prepared by Defense Nuclear Agency

DARE#
23598

DTL890835

ADB132927

DNA 6325

DESTRUCTION NOTICE:

FOR CLASSIFIED documents, follow the procedures in DoD 5200.22-M, Industrial Security Manual, Section II-19.

FOR UNCLASSIFIED, limited documents, destroy by any method that will prevent disclosure of contents or reconstruction of the document.

Retention of this document by DoD contractors is authorized in accordance with DoD 5220.22-M, Industrial Security Manual.

PLEASE NOTIFY THE DEFENSE NUCLEAR AGENCY, ATTN: CSTI, WASHINGTON, DC 20305-1000, IF YOUR ADDRESS IS INCORRECT, IF YOU WISH IT DELETED FROM THE DISTRIBUTION LIST, OR IF THE ADDRESSEE IS NO LONGER EMPLOYED BY YOUR ORGANIZATION.



REPORT DOCUMENTATION PAGE				
1a REPORT SECURITY CLASSIFICATION UNCLASSIFIED		1b RESTRICTIVE MARKINGS		
2a SECURITY CLASSIFICATION AUTHORITY N/A since Unclassified		3 DISTRIBUTION/AVAILABILITY OF REPORT Approved for public release; distribution is unlimited.		
2b DECLASSIFICATION/DOWNGRADING SCHEDULE N/A since Unclassified				
4 PERFORMING ORGANIZATION REPORT NUMBER(S)		5 MONITORING ORGANIZATION REPORT NUMBER(S) DNA 6325F		
6a NAME OF PERFORMING ORGANIZATION Reynolds Electrical and Engineering Co., Inc.	6b OFFICE SYMBOL (if applicable)	7a NAME OF MONITORING ORGANIZATION Joe A. Stinson UNTPR Program Manager		
6c ADDRESS (City, State, and ZIP Code) P.O. Box 98521 Las Vegas, NV 89193-8521		7b ADDRESS (City, State, and ZIP Code) 3300 Embudito Drive NE Albuquerque, NM 87111		
8a NAME OF FUNDING/SPONSORING ORGANIZATION	8b OFFICE SYMBOL (if applicable)	9 PROCUREMENT INSTRUMENT IDENTIFICATION NUMBER		
8c ADDRESS (City, State, and ZIP Code)		10 SOURCE OF FUNDING NUMBERS		
		PROGRAM ELEMENT NO	PROJECT NO	TASK NO
				WORK UNIT ACCESSION NO
11 TITLE (Include Security Classification) OPERATIONS ANVIL, CRESSET, TINDERBOX, AND GUARDIAN: Events Husky Pup, Mighty Epic, Hybla Gold, Diablo Hawk, Huron King, and Miners Iron, 24 October 1975 - 31 October 1980				
12 PERSONAL AUTHOR(S) Brady, William J.; Eubank, Bernard; McDowell, Elizabeth; Stinson, Joe A.				
13a TYPE OF REPORT Technical	13b TIME COVERED FROM 751024 TO 801031	14 DATE OF REPORT (Year, Month, Day) 890430	15 PAGE COUNT 314	
16 SUPPLEMENTARY NOTATION				
17. COSATI CODES		18 SUBJECT TERMS (Continue on reverse if necessary and identify by block number)		
FIELD	GROUP	SUB-GROUP		
18	3			
6	18			
		Underground Nuclear Test Personnel Review (UNTPR) Defense Nuclear Agency (DNA) Nevada Test Site (NTS)		
19 ABSTRACT (Continue on reverse if necessary and identify by block number) This report is a personnel-oriented history of DOD participation in underground nuclear weapons testing during OPERATIONS ANVIL, CRESSET, TINDERBOX, and GUARDIAN: Events Husky Pup, Mighty Epic, Hybla Gold, Diablo Hawk, Huron King, and Miners Iron, 24 October 1975 to 31 October 1980. It is the sixth in a series of historical reports which will include all DOD underground nuclear test participation from 1962 forward. In addition to these historical reports, a restricted distribution report will identify all DOD and DOD affiliated participants, military, civilian, and DOD contractors, and will list their individual radiation dose data.				
20 DISTRIBUTION/AVAILABILITY OF ABSTRACT <input type="checkbox"/> UNCLASSIFIED/UNLIMITED <input checked="" type="checkbox"/> SAME AS RPT <input type="checkbox"/> DTIC USERS		21 ABSTRACT SECURITY CLASSIFICATION UNCLASSIFIED		
22a NAME OF RESPONSIBLE INDIVIDUAL Joe A. Stinson		22b TELEPHONE (Include Area Code) (505) 294-7941	22c OFFICE SYMBOL	

3. DISTRIBUTION/AVAILABILITY OF REPORT (Continued)

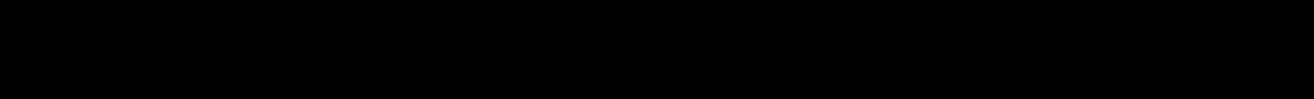

18. SUBJECT TERMS (Continued)

Underground Test (UGT)
ANVIL
CRESSET
TINDERBOX

GUARDIAN
HUSKY PUP
MIGHTY EPIC
HYBLA GOLD

DIABLO HAWK
HURON KING
MINERS IRON

SUMMARY

Six Department of Defense (DOD)-sponsored underground test events were conducted from 24 October 1975 through 31 October 1980 to study weapons effects. Five were tunnel-type nuclear tests, and one was a vertical shaft-type test. The following table summarizes data on these events:

OPERATION	ANVIL		CRESSET		TINDER-BOX	GUARD-IAN
TEST EVENT	HUSKY PUP	MIGHTY EPIC	HYBLA GOLD	DIABLO HAWK	HURON KING	MINERS IRON
DATE	24 Oct 75	12 May 76	1 Nov 77	13 Sep 78	24 Jun 80	31 Oct 80
LOCAL TIME (hours)	1011 PDT	1250 PDT	1005 PST	0815 PDT	0810 PDT	1000 PST
NTS LOCATION	U12t.03	U12n.10	U12e.20	U12n.10a	U3ky	U12n.11
TYPE	Tunnel	Tunnel	Tunnel	Tunnel	Shaft	Tunnel
DEPTH (FEET)	1,142	1,306	1,263	1,273	1,050	1,306
YIELD*	Low	Low	Low	Low	Low	Low

***LOW INDICATES LESS THAN 20 KILOTONS**

No release of radioactive effluent was detected onsite or offsite after any test event discussed in this volume.

As recorded on Area Access Registers, 1,723 individual entries to radiation exclusion (radex) areas were made after the above DOD test events. Of this number 346 were by DOD-affiliated personnel (including military, DOD civilian, and DOD contractor). The remainder were made by United States Energy Research and Development Administration (ERDA)*, other government agency, and other contractor personnel.

The average gamma radiation exposure per entry for all participants was 3 milliroentgen (mR). The average gamma radiation exposure per entry for DOD-affiliated participants was 4 mR. The maximum exposure of a non-DOD participant during an entry was 140 mR. The maximum exposure of a DOD-affiliated participant was 90 mR. These maximum exposures occurred during the MINERS IRON event.

*The U.S. Energy Research and Development Administration (ERDA) succeeded the U.S. Atomic Energy Commission (AEC) on 19 January 1975. ERDA in turn was succeeded by the U. S. Department of Energy on 1 October 1977.

PREFACE

The United States Government conducted 194 nuclear device tests from 1945 through 1958 during atmospheric test series at sites in the United States and in the Atlantic and Pacific Oceans. The U.S. Army's Manhattan Engineer District (MED) implemented the testing program in 1945, and its successor agency, the AEC, administered the program from 1947 until testing was suspended by the United States on 1 November 1958.

Of the 194 nuclear device tests conducted, 161 were for weapons related or effects purposes, and 33 were safety experiments. An additional 24 nuclear experiments were conducted from December 1954 to February 1956 in Nevada. These experiments were physics studies using small quantities of fissionable material and conventional explosives.

President Eisenhower had proposed that test ban negotiations begin on 31 October 1958, and had pledged a one-year moratorium on United States testing to commence after the negotiations began. The Conference on Discontinuance of Nuclear Weapons Tests began at Geneva on 31 October 1958, the U.S. moratorium began on 1 November, and the AEC detected the final Soviet nuclear test of their fall series on 3 November 1958. Negotiations continued until May 1960 without final agreement. No nuclear tests were conducted by either nation until 1 September 1961 when the Soviet Union resumed nuclear testing in the atmosphere. The United States began a series of underground tests in Nevada on 15 September 1961, and U.S. atmospheric tests were resumed on 25 April 1962 in the Pacific.

The United States conducted four atmospheric tests in Nevada during July 1962, and the last U.S. atmospheric nuclear test was in the Pacific on 4 November 1962. The Limited Test Ban Treaty, which prohibited tests in the atmosphere, in outer space, and underwater, was signed in Moscow on 5 August 1963. From resumption of United States atmospheric testing on 25 April 1962 until the last atmospheric test on 4 November 1962, 40 weapons

related and weapons effects tests were conducted as part of the Pacific and Nevada atmospheric test operations. The underground tests, resumed on 15 September 1961, have continued on a year-round basis through the present time.

In 1977, 15 years after atmospheric testing stopped, the Center for Disease Control (CDC)* noted a possible leukemia cluster within the group of soldiers who were at the Nevada Test Site during SMOKY event, one of the Nevada tests in the 1957 PLUMBBOB series. After that CDC report, the Veterans Administration (VA) received a number of claims for medical benefits filed by former military personnel who believed their health may have been affected by their participation in the nuclear weapons testing program.

In late 1977, the DOD began a study to provide data for both the CDC and the VA on radiation exposures of DOD military and civilian participants in atmospheric testing. That study has progressed to the point where a number of volumes describing DOD participation in atmospheric tests have been published by the Defense Nuclear Agency (DNA) as the Executive Agent for the DOD.

On 20 June 1979, the United States Senate Committee on Veterans' Affairs began hearings on Veterans' Claims for Disabilities from Nuclear Weapons Testing. In addition to requesting and receiving information on DOD personnel participation and radiation exposures during atmospheric testing, the Chairman of the Senate Committee expressed concern regarding exposures of DOD participants in DOD-sponsored and Department of Energy (DOE) underground test events.

The Chairman requested and received information from the Director, DNA, in an exchange of letters through 15 October 1979

*The Center for Disease Control was part of the U.S. Department of Health, Education, and Welfare (now the U.S. Department of Health and Human Services). It was renamed The Centers for Disease Control on 1 October 1980.

regarding research on underground testing radiation exposures. In early 1980, the DNA initiated a program to acquire and consolidate underground testing radiation exposure data in a set of published volumes similar to the program then under way on atmospheric testing data. This volume is the sixth of several volumes regarding participation and radiation exposures of DOD military and civilian participants in underground nuclear test events.

SERIES OF VOLUMES.

Most volumes in this series discuss DOD-sponsored underground test events, in chronological order, after presenting introductory and general information. These volumes cover all except one category of underground test events identified as DOD-sponsored in Announced United States Nuclear Tests, published each year by the DOE Nevada Operations Office, Office of Public Affairs. The category of events not covered includes events conducted as nuclear test detection experiments in a program named VELA-UNIFORM. Generally, reentries after these tests were not performed, so significant exposure of participants to radiation did not occur.

A later volume will discuss general participation of DOD personnel in DOE - sponsored* underground test events, with

*On 19 January 1975, just before the detonation of the first event covered by this volume, the Atomic Energy Commission (AEC) was reorganized and part of it became the Energy Research Development Administration (ERDA). During the time period encompassed by this volume, ERDA became the Department of Energy (DOE). For readability and ease of understanding, Chapters 1 and 2 of this volume will use the acronym "DOE" to discuss the general responsibilities and procedures applicable to DOE and each of its predecessor agencies. Any activity which is tied to a specific time period will be discussed using the acronym of the agency in control during that period (i.e., safety experiments were conducted only during the era of the AEC).

specific information on those events which released radioactive effluent to the atmosphere and where exposures of DOD personnel were involved.

A separate set of volumes (comprising one report) is a census of DOD personnel and their radiation exposure data. Distribution of this volume is limited by provisions of the Privacy Act.

METHODS AND SOURCES USED TO PREPARE THE VOLUMES.

Information for these volumes was obtained from several locations. Security-classified documents were researched at Headquarters, DNA, Washington, D.C. Additional documents were researched at Field Command, DNA, the Air Force Weapons Laboratory Technical Library, and Sandia National Laboratories in Albuquerque, New Mexico. Most of the radiation measurement data were obtained at the DOE, Nevada Operations Office (DOE/NV), and its support contractor, the Reynolds Electrical & Engineering Company, Inc. (REECo), in Las Vegas, Nevada.

Unclassified records were used to document underground testing activities when possible, but, when necessary, unclassified information was extracted from security-classified documents. Both unclassified and classified documents are cited in the List of References at the end of each volume. Locations of the reference documents also are shown. Copies of most of the unclassified references have been entered in the records of the Coordination and Information Center (CIC), a DOE facility located in Las Vegas, Nevada.

Radiation measurements, exposure data, event data, and off-site reports generally are maintained in hard copy or microfilm form at the REECo facilities adjacent to the CIC or as original documents at the Federal Archives and Records Center, Laguna Niguel, California. The Master File of all available personnel exposure data for nuclear testing programs on the continent and in the Pacific from 1945 to the present is maintained by REECo for DOD and DOE.

ORGANIZATION OF THIS VOLUME.

A summary of this test event volume appears before this preface and includes general objectives of the test events, characteristics of each test event, and data regarding DOD participants and their radiation exposures.

Section 1, "Introduction", following this Preface and the Table of Contents discusses the historical background, underground testing objectives, DOD and DOE organizational responsibilities, and locations of NTS underground testing areas.

A section entitled "Underground Testing Procedures" explains the basic mechanics of underground testing, including containment problems and procedures, emplacement types, diagnostic techniques, the purpose of effects experiments, tunnel and drilling area access requirements, industrial safety considerations, radiological safety procedures, telemetered measurements of radiation levels, and air support requirements.

A section on each test event covered by this volume follows in chronological order. Each test event section contains an event summary, a discussion of preparations and event operations, an explanation of safety procedures implemented, and listings of monitoring, sampling, and exposure results.

A reference list and appendices to the text, including a glossary of terms and a list of abbreviations and acronyms, follow the event chapters.

TABLE OF CONTENTS

Section	Page
SUMMARY.	iii
PREFACE.	v
LIST OF ILLUSTRATIONS.	xiv
LIST OF TABLES	xvi
1 INTRODUCTION	1
1.1 Historical Background	1
1.2 Underground Testing Objectives	2
1.3 DOD Testing Organizations and Responsibilities	3
1.4 DOE Organizations, Contractors, and Responsibilities	13
1.5 The Nevada Test Site	21
2 UNDERGROUND TESTING PROCEDURES	26
2.1 Containment Problems and Procedures	26
2.2 Emplacement Types	38
2.3 Diagnostic Techniques	45
2.4 Effects Experiments	46
2.5 Tunnel and Drilling Area Access Requirements	47
2.6 Industrial Safety Considerations	51
2.7 Radiological Safety Procedures	54
2.8 Telemetered Measurements of Radiation Levels	60
2.9 Air Support Requirements	66
3 HUSKY PUP EVENT.	69
3.1 Event Summary	69
3.2 Preevent Activities	69
3.3 Event-day Activities	79
3.4 Postevent Activities	82
3.5 Results and Conclusions	89

TABLE OF CONTENTS (Continued)

Section	Page
4 MIGHTY EPIC EVENT	91
4.1 Event Summary	91
4.2 Preevent Activities	91
4.3 Event-day Activities.	101
4.4 Postevent Activities	103
4.5 Results and Conclusions	114
5 HYBLA GOLD EVENT	116
5.1 Event summary	116
5.2 Preevent Activities	116
5.3 Event-day Activities	128
5.4 Postevent Activities	129
5.5 Results and Conclusions	140
6 DIABLO HAWK EVENT.	142
6.1 Event Summary	142
6.2 Preevent Activities	142
6.3 Event-day Activities	154
6.4 Postevent Activities	156
6.5 Results and Conclusions	169
7 HURON KING EVENT	171
7.1 Event Summary	171
7.2 Preevent Activities	171
7.3 Event-day Activities	184
7.4 Postevent Activities	189
7.5 Results and Conclusions	191
8 MINERS IRON EVENT.	193
8.1 Event Summary	193
8.2 Preevent Activities	193

Section	TABLE OF CONTENTS (Concluded)	Page
8.3	Event-day Activities	204
8.4	Postevent Activities	206
8.5	Results and Conclusions	213
9	LIST OF REFERENCES	215
APPENDICES		
A	Glossary of Terms	219
B	Abbreviations and Acronyms.	251
C	General Tunnel Reentry Procedures for Department of Defense and Sandia Laboratory Nuclear Tests. . .	255
D	U.S. Atomic Energy Commission Standard Operating Procedure Chapter 0524 - Radiological Safety. . . .	269
E	U.S. Atomic Energy Commission Standard Operating Procedure Chapter 0101 - The Nevada Test Site Organization (NTSO)	293

LIST OF ILLUSTRATIONS

Figure		Page
1.1	Federal Government Structure for Continental Nuclear Tests	4
1.2	Partial Organization Chart of Field Command, Defense Nuclear Agency.	8
1.3	Nevada Test Site Organization	17
1.4	Nellis Air Force Range and NTS in Nevada	22
1.5	The Nevada Test Site	23
2.1	A Typical Subsidence Crater	41
2.2	Vertical LOS Pipe Configuration	42
2.3	Horizontal LOS Pipe Configuration	44
2.4	Portal of a Typical DOD Tunnel Complex	53
2.5	NTS Combination Personnel Dosimeter and Security Credential Holder	57
2.6	Neher-White RAMS Probe	62
2.7	RAMS Readout Console	63
2.8	Typical Remote Radiation Detection Monitoring System for Shaft-Type Emplacement Site	64
2.9	Typical Permanently-Established Remote Radiation Detector Stations Operated Continuously Throughout the NTS	65
3.1	HUSKY PUP Event - Tunnel Layout	70
3.2	HUSKY PUP Event - System Configuration.	72
3.3	HUSKY PUP Event - Surface RAMS.	77
3.4	HUSKY PUP Event - Underground RAMS.	78
3.5	Aerial View of the U12t Portal and Mesa Areas	81
4.1	MIGHTY EPIC Event - Tunnel Layout	92
4.2	MIGHTY EPIC Event - Tunnel and Pipe Layout.	95
4.3	MIGHTY EPIC Event - Surface RAMS.	99
4.4	MIGHTY EPIC Event - Underground RAMS.	100
4.5	MIGHTY EPIC Event - Postevent Reentry Mining and Coring Locations.	110
5.1	HYBLA GOLD Event - Tunnel Layout.	117
5.2	HYBLA GOLD Event - Experiment Pipes	119
5.3	HYBLA GOLD Event - Drift Plan	120
5.4	HYBLA GOLD Event - Surface RAMS	126
5.5	HYBLA GOLD Event - Underground RAMS	127

LIST OF ILLUSTRATIONS (Concluded)

Figure		Page
6.1	DIABLO HAWK Event - Tunnel Layout	143
6.2	DIABLO HAWK Event - Preevent Mining	146
6.3	DIABLO HAWK Event - Structure Experiments	147
6.4	DIABLO HAWK Event - Surface RAMS.	152
6.5	DIABLO HAWK Event - Underground RAMS.	153
6.6	DIABLO HAWK Event - Reentry Mining.	161
7.1	HURON KING Event - VLOS Pipe System	174
7.2	HURON KING Event - Major Components of the Experiment Tank Prior to Assembly	175
7.3	HURON KING Event - Experiment Tank Positioned Over the VLOS Pipe System	176
7.4	HURON KING Event - Aerial View of U3ky Prior to Device Detonation	177
7.5	HURON KING Event - Front and Left Side of STARSAT	179
7.6	HURON KING Event - Surface RAMS and M-102 Units . . .	183
7.7	HURON KING Event - Experiment Tank Postevent Position.	186
7.8	HURON KING Event - Subsidence Crater.	187
8.1	MINERS IRON Event - Tunnel Layout	194
8.2	MINERS IRON Event - OBP Before Concrete Pour.	196
8.3	MINERS IRON Event - Tunnel and Pipe Layout.	197
8.4	MINERS IRON Event - Surface RAMS.	202
8.5	MINERS IRON Event - Underground RAMS.	203

LIST OF TABLES

Table		Page
2.1	DOD Test Events - 24 October 1975 through 31 October 1980	39
3.1	HUSKY PUP Event RAMS Unit Locations	75
4.1	MIGHTY EPIC Event RAMS Unit Locations	97
5.1	HYBLA GOLD Event RAMS Unit Locations.	124
6.1	DIABLO HAWK Event RAMS Unit Locations	150
6.2	DIABLO HAWK Reentry Drift Radiation Summary	162
7.1	HURON KING Event RAMS and M-102 Unit Locations	182
8.1	MINERS IRON Event RAMS Unit Locations	200

SECTION 1

INTRODUCTION

The first United States nuclear detonation designed to be fully contained underground was the RAINIER tunnel event conducted by the University of California Radiation Laboratory (UCRL) for the AEC in Nevada on 19 September 1957. This was a weapons-related experiment with a relatively low yield of 1.7 kilotons (kt). The second tunnel event with a significant nuclear yield was a safety experiment on 22 February 1958, also conducted in Nevada by UCRL for the AEC. This experiment, the VENUS event, resulted in a yield of less than one ton. These two tunnel events and five additional underground safety experiments with zero or only slight yields were the beginning of the United States underground nuclear testing program, currently the only type of nuclear detonation testing permitted by treaty. The first DOD-sponsored underground nuclear weapons effects test was the 5.7 kt HARD HAT event conducted by the Defense Atomic Support Agency (DASA) on 15 February 1962 in Nevada.

1.1 HISTORICAL BACKGROUND.

While technical conferences between the United States and the Soviet Union on banning nuclear detonation tests continued, and concern regarding further increases in worldwide fallout mounted, a number of nuclear tests were conducted underground during 1958 in Nevada. Prior to the United States testing moratorium, six safety experiments in shafts, five safety experiments in tunnels, and four weapons-related tests in tunnels were conducted by user laboratories. Radioactive products from several of these tests were not completely contained underground. Containment of nuclear detonations was a new engineering challenge. Understanding and solving the majority of containment problems would require years of underground testing experience.

When the United States resumed testing on 15 September 1961, the first 32 test events were underground, including a cratering

experiment with the device emplaced 110 feet below the surface. The DOMINIC I test series in the Pacific and the DOMINIC II test series in Nevada (also called Operation SUNBEAM by DOD) during 1962 were the last atmospheric nuclear detonation tests by the United States.

The commitment of the United States to reduce levels of worldwide fallout by refraining from conducting nuclear tests in the atmosphere, in outer space, and underwater was finalized when the Limited Test Ban Treaty with the Soviet Union was signed on 5 August 1963. On 31 March 1976, the Soviet Union and the United States agreed to limit the maximum yield of underground tests to 150 kt. Currently, yields are reported as within a particular range; less than 20 kt, less than 150 kt, or 20 to 150 kt.

1.2 UNDERGROUND TESTING OBJECTIVES.

The majority of United States underground tests have been for weapons-related purposes. New designs were tested to improve efficiency and deliverability characteristics of nuclear explosive devices before they entered the military stockpile as components of nuclear weapons.

In addition to weapons-related tests, safety experiments with nuclear devices also were conducted by user laboratories. These experiments tested nuclear devices by simulating nuclear detonation using conventional high explosives in a manner which might occur in an accident during transportation or storage of weapons.

Weapons effects tests sponsored by the DOD were conducted to determine the vulnerability or survivability of military systems or components when exposed to one or more effects of a nuclear detonation. The nuclear devices for these tests were provided by the DOE weapons development laboratories and were designed to be similar to the nuclear components used in nuclear weapons. Actual weapon configurations were used in a few test events. Military systems, structures, materials, electronics experiments, and other related experiments were provided by DOD and DOE

agencies. Many of these tests were very complex and involved greater numbers of participants than other categories of tests previously mentioned. Personnel from DNA, other government organizations, user laboratories and contractors, and DOD contractor agencies were involved.

Some tests were designed to study the response of hardened structures or geologic formations to shock waves generated by nuclear detonations. Many tests were designed to study the response of military components to effects of radiation produced by nuclear weapons. Such tests required a direct line of sight between the nuclear device and the experiments. Many of the radiation effects tests required the simulation of high altitude (up to exoatmospheric) conditions. These tests involved installation of experiments inside large steel line-of-sight (LOS) pipes, hundreds of feet in length, with maximum diameters of several feet. Large vacuum pumps were utilized to reduce pressure inside the pipes to the desired level.

DOD weapons effects tests HUSKY PUP, 24 October 1975, through MINERS IRON, 31 October 1980, conducted during Operations Anvil, Cresset, Tinderbox, and Guardian are discussed in this volume.

1.3 DOD TESTING ORGANIZATIONS AND RESPONSIBILITIES.

Administering the underground nuclear testing program was a joint DOE-DOD responsibility. The similar nature of the DOE-DOD organizational structure is shown in Figure 1.1.

1.3.1 Defense Nuclear Agency.

Headquarters of DNA is located near Washington, D.C., and is composed of personnel from each of the Armed Services and civilian DOD employees. It was originally established as the Armed Forces Special Weapons Project (AFSWP) to assume residual functions of the Manhattan Engineer District (MED), through issuance of a joint Army-Navy memorandum, dated 29 January 1947, which was retroactive to 1 January 1947 (when the Atomic Energy

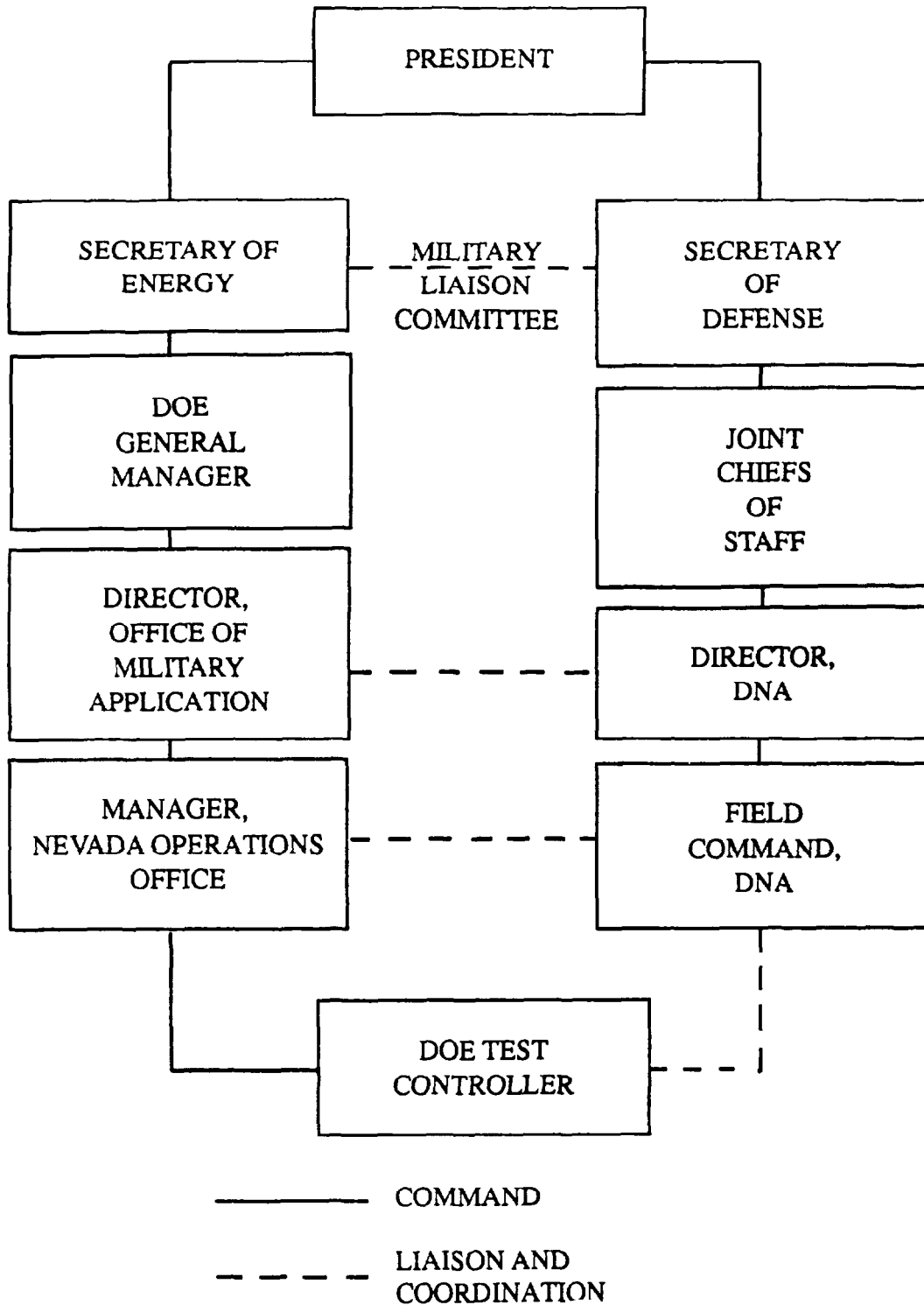

Figure 1.1 Federal government structure for continental nuclear tests (1977).

Commission was activated). The responsibility for DOD nuclear weapons effects testing was assigned to AFSWP. The National Security Act of 1947 had become law when the Secretary of Defense issued a memorandum on 21 October 1947 to the three Service Secretaries confirming the previous directive of 29 January, and thus, AFSWP officially represented all of the services. AFSWP was charged with providing nuclear weapons support to the Army, Navy, and Air Force. As originally chartered, AFSWP was directly responsible to each of the three Service Chiefs. In 1951, the Air Force Special Weapons Center (AFSWC) located at Kirtland Air Force Base (KAFB), Albuquerque, New Mexico, was assigned by DOD the responsibility to provide specific support to the AEC for continental nuclear testing (see Section 1.3.2). This command was not directly related to AFSWP; however, the two organizations coordinated several support tasks.

By issuance of General Order No. 2, Headquarters, DASA (HQ/DASA), dated 6 May 1959, AFSWP became DASA. Under its new charter, DASA was responsible to the Secretary of Defense through the Joint Chiefs of Staff.

DASA's five major areas of responsibility for the DOD included:

1. Staff assistance to the Office of the Secretary of Defense, through the Joint Chiefs of Staff.
2. Research in weapons effects.
3. Atomic tests.
4. Weapons-related tests.
5. Assistance to the Services.

Responsibilities of HQ/DASA, included providing consolidated management and direction for the DOD nuclear weapons effects testing programs, while technical direction and management of field operations of DOD nuclear weapons effects testing

activities were delegated to Field Command, DASA (FC/DASA), located at Sandia Base (now KAFB) in Albuquerque, New Mexico. From 6 May 1959 until 1 July 1964 the Weapons Effects Tests Group (WETG) of FC/DASA was responsible for nuclear weapons effects testing and seismic detection research (VELA-UNIFORM) for the Director, DASA. This organization maintained close liaison with the AEC/Nevada Operations Office (NVOO). Personnel from FC/DASA became the military members of the joint AEC-DOD testing organization at the Nevada Test Site (NTS) and at other Continental United States test locations. Participation of DOD agencies and their contractors in nuclear field tests was coordinated and supported by FC/DASA. On 1 July 1964, the testing organization in Albuquerque was designated as the Weapons Test Division (WTD), a division of HQ/DASA. On 1 August 1966, WTD was changed to Test Command (TC/DASA), a separate command under HQ/DASA, but remained in Albuquerque. The responsibilities for technical direction and management of field operations for nuclear weapons effects tests remained in effect during these changes in organization. During this period, WTD and TC maintained an engineering and support branch (designated Nevada Branch) at the NTS and a liaison office at AEC/NVOO. The Nevada Branch maintained liaison with AEC/NVOO and supervised FC/DASA activities at NTS. On 12 May 1970, the Commander, FC/DASA, assumed additional command of TC/DASA.

On 29 March 1971 (effective 1 July 1971), the Deputy Secretary of Defense directed the reorganization of DASA as a result of cutbacks recommended by the "Blue Ribbon Panel" survey of agency activities. In his Executive Memorandum, DASA was retained as a defense agency under the new title, "Defense Nuclear Agency." On 1 July 1971, FC/DASA was redesignated as FC/DNA, and TC/DASA became TC/DNA. While the responsibilities and manning levels at Field Command were reduced during this transition, Test Command remained essentially the same.

On 1 January 1972, TC/DNA was disestablished and personnel were transferred to FC/DNA. The responsibilities for technical direction and management of field operations for nuclear weapons effects tests were transferred to the newly formed Test

Directorate (Field Command Test [FCT]), of FC/DNA. The Nevada Branch of TC was changed to the Test Construction Division of Test Directorate (FCTC), and the responsibility for the liaison office at AEC/NVOO was transferred to FCTC. (See Figure 1.2.)

1.3.2 Air Force Support.

Until 1 July 1974, AFSWC provided air support to the Nevada Test Site Organization (NTSO) during nuclear tests at the NTS. Detachment 1 of the 4900th Test Group provided aircraft for shuttle service between KAFB, New Mexico, and Indian Springs Air Force Auxiliary Field (ISAFAF) in Nevada. They also provided aircraft and crews to perform low-altitude cloud tracking, radio relay support, and courier missions. On 1 July 1974, AFSWC'S air support responsibility, along with Detachment 1, 4900th Test Group, was transferred to the 57th Fighter Weapons Wing (FWW), Tactical Air Command, at Nellis Air Force Base, Nevada. AFSWC continued to support the Air Force's nuclear research and development (R&D) mission until 1 April 1976 when it was deactivated. (The nuclear R&D mission was transferred to the Air Force Weapons Laboratory [AWFL], KAFB, New Mexico, at this time.) Detachment 1 remained at ISAFAF and continued to provide support to the NTS; however, personnel, aircraft, equipment, and supplies became the responsibility of the FWW. Support was formalized by Interservice Support Agreements between the Tactical Fighter Weapons Center (as represented by the 57th FWW) and FC/DNA, acting as the agent of the Departments of Defense and Energy for receiving aeronautical support at NTS. Operations provided by Detachment 1 during this period were:

- A. An airborne security inspection of pre-closed areas on D-1.
- B. A D-day airborne safety inspection and Test Controller standby mission to be flown prior to D-11 hours and to cover the downwind area for personnel and livestock locations. (The standby portion of this mission was for rapid evacuation of personnel and/or reentry of scientific personnel, if necessary.)

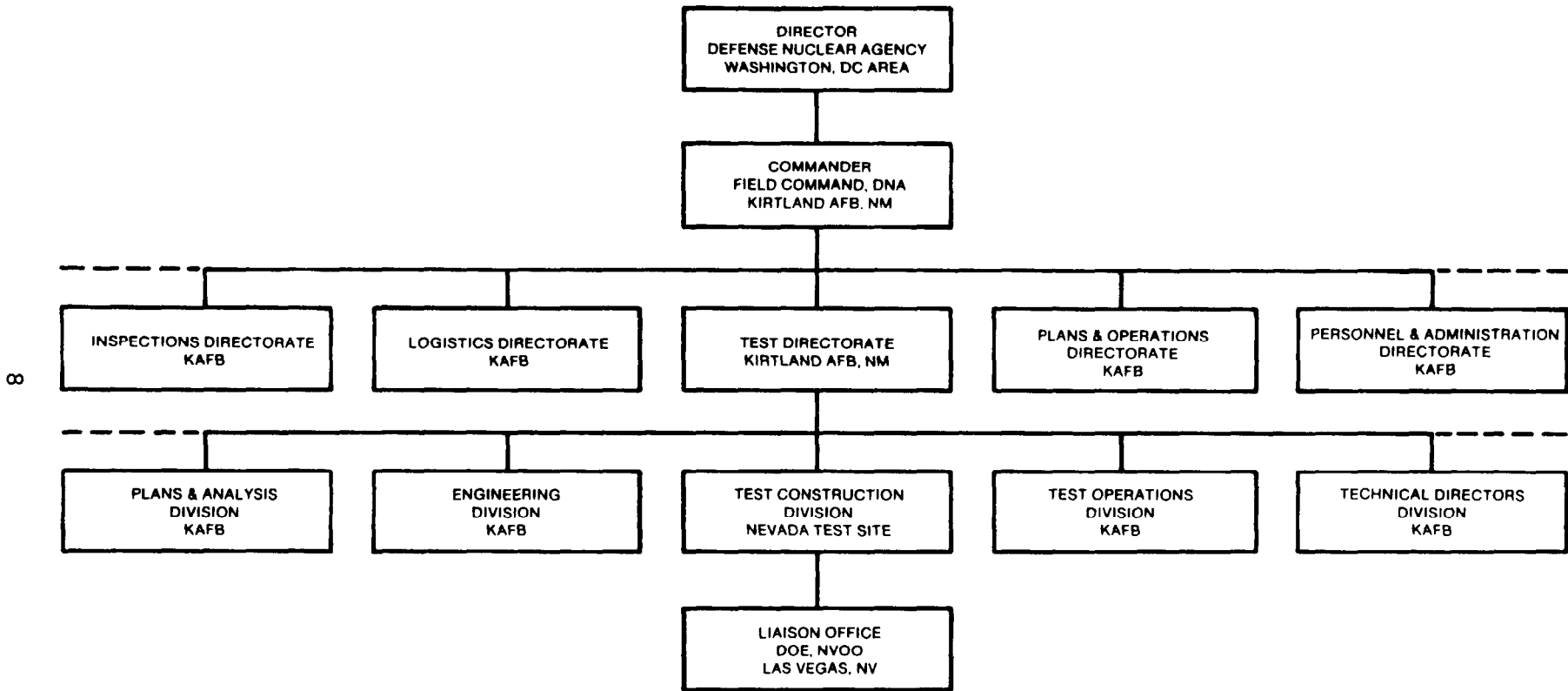

Figure 1.2 Partial organization chart of Field Command, Defense Nuclear Agency (1980).

- C. A D-day helicopter airborne closed-circuit television mission to provide a stable platform for both television and color photography coverage of surface ground zero at zero time.
- D. A D-day helicopter cloud surveillance to provide initial data for immediate "on-site" decisions regarding safeguard actions. (Not to be considered as "cloud tracking.")
- E. Damage survey flights, as required, and other support flights as requested by the Test Controller and as operationally feasible by the 57th FWW Deputy Commander for Operations.
- F. Normal technical support and laboratory photography flights, as required, including surveys of preshot, postshot, and new construction areas.
- G. An airborne security inspection to cover the NTS boundary, checking the locked barricades, and looking for areas where intruders might have gained access to the NTS unobserved.
- H. Operational orientation tours and management surveillance flights as requested by FC/DNA or the 4900th Test Group.

1.3.3 DOE-DOD Relationships.

DOD was responsible for establishing criteria for nuclear weapons, developing and producing delivery systems, developing nuclear weapons plans and forces, providing defense against nuclear attack, and obtaining nuclear weapons effects data through DNA. DOE was responsible for research, development, production, and supply of nuclear weapons to the Armed Forces in quantities and types specified by the Joint Chiefs of Staff. Quantities and types of weapons were described in the Nuclear Weapon Stockpile Memorandum, signed jointly by the Secretary of

Defense and Secretary of Energy or his alternate, and approved by the President. DOE in association with DOD, also was responsible for providing field nuclear test facilities in the Continental United States and on islands in the Pacific.

The principal points of field coordination between DOE and DOD were at the Nevada Operations Office (NV) in Las Vegas and at NTS. From the beginning of the DOD underground nuclear weapons effects test program (the first test was HARD HAT in February 1962) through the period covered by this volume, Field Command (or Test Command) was the fielding agency for DOD-DNA and served as primary point of contact with the Nevada office of the DOE. DOE/NV represented DOE in the field for all Continental tests. The DOE nuclear weapons development laboratories fielded underground tests as part of the weapons development program; DNA fielded underground tests at NTS to obtain weapons effects data. Because the NTS was a DOE installation, the Manager, NV, was responsible for all operations there.

For each DOD-sponsored test, HQ/DNA coordinated requirements with the military services. Requirements for testing to determine the nuclear vulnerability or hardening of military systems or components were submitted by these organizations. As part of long-range underground nuclear weapons effects test planning, HQ/DNA developed a schedule of specific events designed to satisfy military requirements. One or more of the DOD agencies were cosponsors and, usually, active participants in each DOD underground test. The initial approval of DOD experiments and the selection of the nuclear source (device) for each test was accomplished at the HQ/DNA level. A request for the appropriate nuclear device and associated support was forwarded by HQ/DNA to the Director, Division of Military Application, DOE. The DOE assigned one or more of the weapons development laboratories to provide the device support.

Following initial planning, the responsibility for detailed planning, engineering, fielding, execution, and reporting was assigned to FC/DNA. Field Command formed a Test Group staff for each test. The Technical Director (normally a military officer

assigned to FC/DNA or AFWL) was appointed by HQ/DNA. The Test Group Director and other members of the staff were appointed by FC/DNA. The Test Group Engineer normally was selected from FCTC, Nevada Branch.

The Test Group staff developed detailed test plans and schedules. Engineering and construction plans were developed by Nevada Branch and coordinated with NTSO. Final engineering designs were developed by DOE contractors at NTS - Holmes & Narver, Inc. (H&N), and/or Fenix & Scisson, Inc. (F&S). Engineering drawings were approved by FCTC and NTSO prior to actual construction. Construction was performed by the principal DOE support contractor - REECo. FCTC and members of the Test Group staff monitored construction activities. The FC/DNA Test Group staff coordinated development of technical experiments and initiated action to obtain required support equipment (e.g., steel LOS pipe and mechanical closures). The Test Group staff reviewed the technical support requirements submitted by experimenter agencies and transmitted consolidated requirements to the Nevada Operations Office which, in turn, advised the NTSO of future requirements.

During the construction phase, the Nevada Operations Office began collecting containment-related information. During drilling or mining operations, rock cores were analyzed for bulk density, moisture content, grain density, porosity (determined by the difference between bulk and grain densities), unconfined compressive strength, triaxial compression (for a variety of confining pressures), ultrasonic shear and compressive wave velocities, carbon dioxide content, presence of clay which could swell, and other features. Testing was done for DNA primarily by the H&N Testing Lab at NTS (Mercury) and Terra Tek, a DNA contractor located at Salt Lake City, Utah, as part of the DNA containment research program.

Geologic features of the tunnels were examined and mapped as construction progressed, usually by an DOE contractor. Several months prior to planned event execution, FC/DNA prepared a document which contained a general description of the test, site

geologic information, types and locations of mechanical closures, details of concrete plugs, a summary of analytical calculations, and other related test history. This document was reviewed by Containment Evaluation Panel (CEP, see section 2.1.3) members and formally presented by FC/DNA to the CEP for categorization and recommendation for execution.

The FC/DNA Test Group staff normally moved to NTS a few months prior to the planned event execution date (three to six months depending upon the complexity of the test). Prior to arrival of DOD experimenter personnel, the Nevada Operations Office made arrangements to provide required instrumentation and recording facilities, office space and equipment, communications equipment, vehicles, photography, and other support items. Housing and food services for DOD personnel at NTS were provided by REECO. Upon arrival at NTS, DOD personnel were briefed on safety and security by the Test Group staff and other DOD and DOE personnel. Experimenter agencies were provided with copies of FC/DNA security and safety plans. These briefings included radiation safety control policies, procedures, and equipment.

Under the supervision of the Test Group staff, experimenter personnel installed experiments and checked out instrumentation cables and recording systems. A series of electrical dry runs were conducted from the participating (user) laboratory control room and DNA monitor room at the Control Point (CP) complex (see section 1.5) to determine that all signals and remotely-controlled equipment were functioning properly. After all systems were declared ready, permission was requested from the DOE to install the nuclear device. Installation and check out were conducted by the participating device development laboratory with DOE security safeguarding the device and other classified materials. The next activities consisted of placing stemming materials in preplanned locations and checking all containment features.

When the test facility was ready for event execution, control of the entire test and experiment area was transferred to the DOE/NV Test Controller and his staff. When the Test

Controller was satisfied that all conditions were satisfactory to detonate the device, he gave permission to the user laboratory to arm the device and initiate the final countdown.

The Test Controller and his staff at the CP monitored the countdown, detonation, and postevent response of remotely controlled radiation monitoring equipment. When released by the Test Controller, REECo Radiological Safety (Radsafe) teams entered the area to monitor for radiation and other safety hazards. After assurance that reentry could be accomplished, the Test Controller released experimenters to collect recorded data from surface areas. All of these operations were conducted in accordance with preevent plans developed by the DOE Test Controller staff, the DOD test group staff, and Nevada Branch personnel, unless postevent conditions required modifications.

For tunnel events, initial reentry into the tunnel was authorized by the DOE Test Controller after it was determined that conditions were safe for reentry operations. Tunnel reentry was controlled by Nevada Branch personnel with assistance from Sandia National Laboratory (SNL) health physicists, REECo Radsafe personnel, and REECo construction personnel. After the tunnel was declared safe for experiment recovery, the Test Group staff assumed control of the area. Based on REECo Radsafe monitoring data, FC/DNA personnel determined when it was safe to remove the experiments. Experimenters then removed experiments for analysis and documentation of results.

1.4 DOE ORGANIZATIONS, CONTRACTORS, AND RESPONSIBILITIES.

1.4.1 Atomic Energy Commission.

The AEC was created by the Atomic Energy Act of 1946 in July, the same month the Joint Chiefs of Staff were conducting Operation CROSSROADS with assistance from the U.S. Army's Manhattan Engineer District. MED was disestablished and the AEC and AFSWP assumed MED functions on 1 January 1947. The Atomic Energy Act was revised in 1954 and has been amended extensively since.

The AEC established headquarters (AEC/HQ) offices in Washington, D.C., and operations offices in areas which were centers of AEC operations. In areas of lesser activity, area offices, branch offices, and field offices were established. The Director of the Division of Military Application (DMA) in AEC/HQ was delegated responsibility for the nuclear weapons development and testing program. The Director of DMA was always a flag officer of one of the armed forces, as specified by the Atomic Energy Act of 1954, and he was an Assistant General Manager in the AEC organization.

In 1951, the Director of DMA designated and delegated his responsibility for conduct of on-continent tests to the Test Manager, who also was Manager of the AEC Santa Fe Operations Office (SFOO) near Los Alamos Scientific Laboratory. Later in 1951, SFOO was moved to Albuquerque. With delegated authority from the Director of DMA, the Manager, SFOO, designated Test Managers for on-continent tests. The same authority applied when SFOO became the Albuquerque Operations Office (ALOO) in 1956. The AEC Las Vegas Field Office (LVFO), established in 1951, managed the Nevada Test Site (called the Nevada Proving Ground from 1952 to 1955) for the Test Manager. LVFO became a branch office in 1955, an Area Office in 1960, and the Nevada Operations Office (NVOO, later shortened to NV) in 1962, with the Manager, NVOO, or his representative designated as Test Manager. In 1972, the Test Manager became the Test Controller.

The Director of DMA* initiated the chain of authority and approval for detonating each nuclear device by requesting that each user laboratory and DNA submit proposed test programs to DMA. This request was made in the spring of each year for tests to be conducted in the next fiscal year. DMA consolidated proposed test programs, developed a test program proposal while consulting with DOD, and generated a program approval request. DMA then presented the proposed test program to the National Security Council (NSC) Ad Hoc Committee on Nuclear Testing.

*The Division of Military Application (DMA) was changed in 1977 to the Office of Military Application (OMA).

Chaired by the NSC, this committee included representatives of the DOD, Joint Chiefs of Staff, Department of State, Arms Control and Disarmament Agency, Office of Management and Budget, Office of Science and Technology, and Central Intelligence Agency. After incorporating informal Committee comments, DMA forwarded the proposed program from the Secretary of Energy to the President through the NSC. The NSC solicited and incorporated formal comments in its recommendation to the President.

Test program approvals were requested at six-month intervals. Approval of tests for the first six months was received at the beginning of each fiscal year. The process was repeated six months later for tests in the last half of the fiscal year. Presidential approvals were signed by the Assistant to the President for National Security Affairs. Subsequently, test program authority messages were sent from the Director of DMA to the user laboratories, DNA, and DOE/NV.

Authority to detonate each nuclear device was handled separately and individually. The technical content of detonation authority requests originated in presentations to the CEP by the user laboratory or DNA. After recommendations by the CEP, the Manager, NV, requested detonation authority from DMA. Required information in each request included statements on compliance with treaties, environmental impact, public announcement plans, test program authority, and any particularly noteworthy aspects of the test. After DMA and additional DOE reviews, the Manager, NV, was notified of detonation authority approval.

As previously mentioned, DOE succeeded ERDA on 1 October 1977, which had succeeded the AEC on 19 January 1975. The HUSKY PUP and MIGHTY EPIC events (see Chapters 3 and 4 of this volume) were conducted under the control of ERDA. The other events in this volume occurred under the control of the DOE.

1.4.2 Nevada Test Site Organization.

As stated in Chapter 0101 of the Nevada Test Site Organization Standard Operating Procedure (NTSO SOP Chapter 0101-01, see Appendix E), the NTSO included DOE, DOD, user laboratory, contractor, agency, and organizational personnel who participated in or provided support for test operations at the NTS. The Manager, NV, headed the NTSO. (See Figure 1.3.) The NTSO was a continuing task organization whose composition could be readily changed in response to the needs and technical objectives of each test. The Continental Test Organization (CTO)* was part of the original NTSO; however, it was disestablished on 1 August 1962 with its responsibilities (e.g., Military Deputy to the Manager, NVOO) being assumed by FC/DASA, WETG and subsequently by FC/DNA, Test Directorate. The Military Deputy to the Test Manager, as shown in Figure 1.3, was from Field Command and was responsible for coordinating DOD programs and support to NTSO.

1.4.3 NTSO Radiological Safety.

The Test Controller was responsible for protection of participating personnel and offsite populations from radiation hazards associated with activities conducted at NTS. By mutual agreement between the Test Controller and a scientific user (see section 1.4.4), control of radiation safety within the area assigned for a particular activity was delegated to the user's Test Group Director during the period of time when such control could have had a direct bearing on the success or failure of the scientific program.

The onsite radiological safety support contractor (REECo Radsafe) was responsible to the Test Manager for both routine and test event radiological safety onsite as detailed in Appendix D, AEC NTSO SOP Chapter 0524**, "Radiological Safety." During test

* See DNA 6320F for additional information

**AEC NTSO SOP Chapter 0524 was not superseded until 23 July 1982.

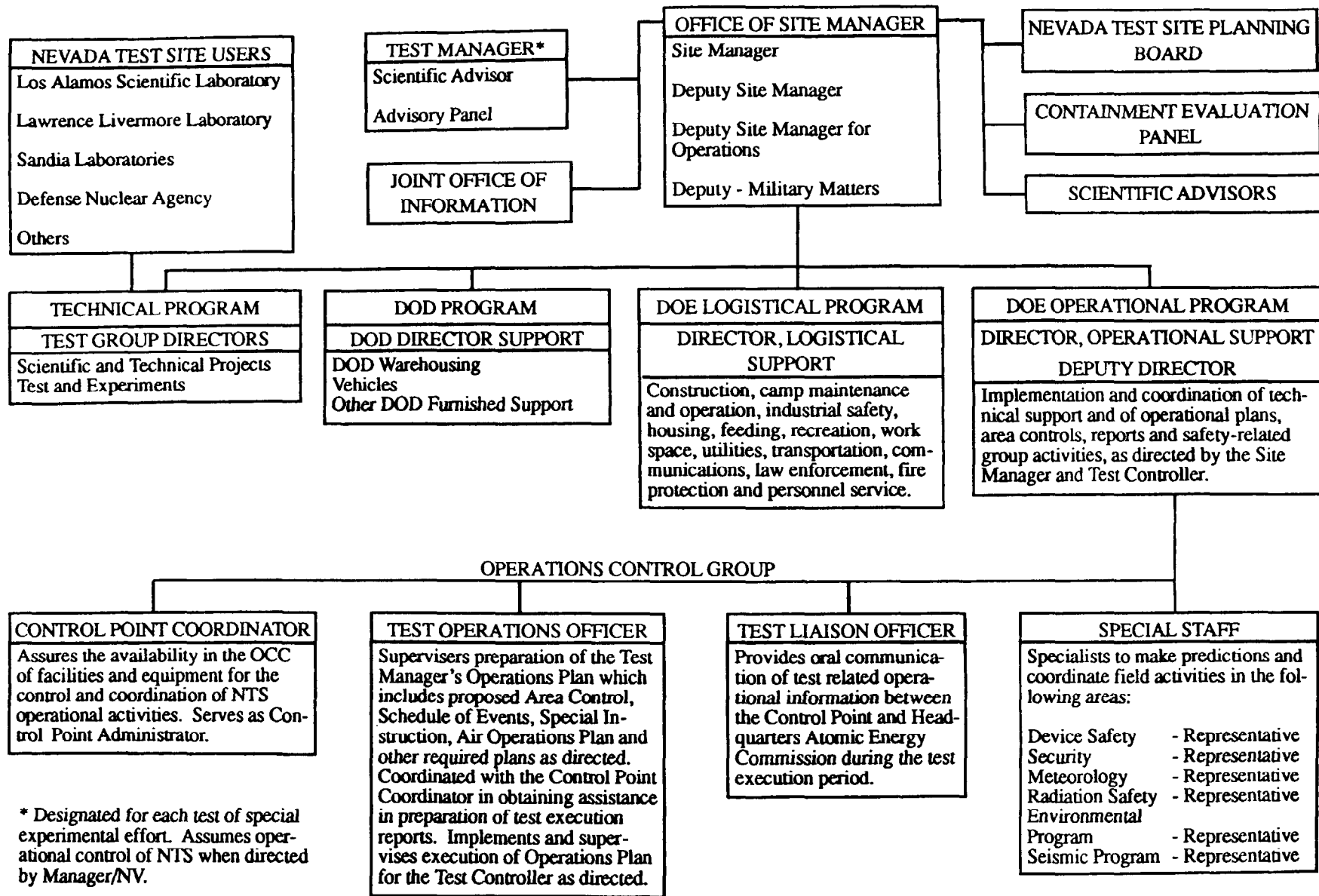

* Designated for each test of special experimental effort. Assumes operational control of NTS when directed by Manager/NV.

Figure 1.3 Nevada Test Site Organization (1980).

events, as shown in Figure I of Appendix D and as discussed above, the Test Manager delegated control of radiation safety in the immediate test area to the user Test Group Director when the Director requested control. When this occurred, each radsafe coordinator was responsible to the Test Group Director through his radiological safety organization for support in his test area.

The U.S. Environmental Protection Agency (EPA), was responsible to the Test Controller for operation of the offsite radiological safety program in accordance with procedures listed in Appendix D.

1.4.4 NTS Scientific Users.

The NTS scientific users were DNA (for nuclear weapons effects) and the development laboratories: Los Alamos Scientific Laboratory (LASL), Lawrence Livermore Laboratory (LLL), and Sandia Laboratories, Albuquerque (SLA). LASL and LLL were primarily involved in testing for weapons development while SLA conducted a limited number of weapons effects tests and supported weapons development tests. On 29 December 1979, Congress passed a bill changing LASL, LLL, and SLA into national laboratories. The names of these organizations changed to the Los Alamos National Laboratory (LANL), Lawrence Livermore National Laboratory (LLNL), and Sandia National Laboratory (SNL), respectively. A brief description of these laboratories follows:

- A. LANL was established early in 1943 as Los Alamos, Project Y, of the MED for the specific purpose of developing an atomic bomb. Los Alamos scientists supervised the test detonation of the world's first atomic weapon in July 1945 at the TRINITY site in New Mexico. Los Alamos became LASL in January 1947, when the AEC and AFSWP were activated to replace the MED. The Laboratory's continuing assignment was to conceive, design, test, and develop nuclear components of atomic weapons.

The contract under which LASL performed work for the AEC was administered first by the Commission's Santa Fe Operations Office and later by the Albuquerque Operations Office. The Laboratory was operated by the University of California.

- B. LLNL (originally the University of California Radiation Laboratory [UCRL], then the name was changed several times, first to the Lawrence Radiation Laboratory [LRL] then to the Lawrence Livermore Laboratory [LLL], and finally to the Lawrence Livermore National Laboratory [LLNL]) was established as a second AEC weapons laboratory at Livermore, California, in 1952. The Laboratory's responsibilities essentially were parallel to those of LASL. Devices developed by LLL first were tested in Nevada in 1953, and LLL-developed devices have been tested in each Continental and Pacific series since. The contract under which LLL performed work for the AEC was administered by the Commission's San Francisco Operations Office. This Laboratory also was operated by the University of California.

- C. SNL (originally Sandia Laboratory) at Sandia Base (now KAFB), Albuquerque, New Mexico, was the AEC's other weapons laboratory. It was established in 1945 as a branch of Los Alamos. In April 1948 it was named Sandia Laboratory Branch of Los Alamos Scientific Laboratory; and in 1949 assumed its identity as a full-fledged weapons research institution operated by the Sandia Corporation, a non-profit subsidiary of Western Electric. SLA's role was to conceive, design, test, and develop the non-nuclear phases of atomic weapons and to do other work in related fields. In 1956, a Livermore Branch of SLA was established to provide closer support to developmental work of the LLL. Sandia Laboratories also operated ballistic test facilities for the AEC at the Tonopah Ballistics Range (now Tonopah Test Range) near Tonopah, Nevada.

1.4.5 Test Support Organizations.

In keeping with its policy, DOE used private contractors for maintenance, operations, and construction (including military and civil defense construction) at the NTS. NV personnel administered all housekeeping, construction, and related services activity, but performance was by contractors. Major support contractors were the following:

Reynolds Electrical & Engineering Company, Inc., was the principal DOE operational and support contractor for the NTS, providing electrical and architectural engineering, state-of-the-art large diameter and conventional shaft drilling, heavy-duty construction and excavation, mining and tunneling, occupational safety and fire protection, radiological safety, toxic gas and explosive mixture monitoring, communications and electronics, power distribution, occupational medicine, and other support functions. REECO maintained offices in Las Vegas and extensive facilities necessary to operate at NTS.

Edgerton, Germeshausen & Grier, Inc., (later renamed EG&G, Inc.) was the principal technical contractor, providing control point functions such as timing and firing, and diagnostic functions such as scientific photography and measurement of detonation characteristics. In addition, EG&G personnel manned the DOD monitor room. EG&G support facilities were maintained in Las Vegas and at NTS.

Holmes & Narver, Inc., performed architect/engineer services for the NTS and was the principal support contractor for the Commission's off-continent operations. H&N had a home office in the Los Angeles area and also maintained offices in Las Vegas and at NTS.

Since 1963, Fenix & Scisson, Inc. of Tulsa, Oklahoma, was a consultant architect/engineer for drilling and mining operations in connection with underground nuclear testing. The company was involved in design of many underground

structures and in the field of deep, large-diameter hole drilling. Las Vegas Branch activity was conducted from offices in Las Vegas and Mercury, Nevada.

Numerous other contractors, selected on the basis of lump-sum competitive bids, performed various construction and other support functions for the DOE and DOD.

1.5 THE NEVADA TEST SITE.

An on-continent location was selected for conducting nuclear weapons tests; construction began at what was called the Nevada Test Site in December 1950, and testing began in January 1951. The name was changed to the Nevada Proving Ground (NPG) in March of 1952 and again changed to the Nevada Test Site on 31 December 1954.

The original boundaries were expanded as new testing areas and projects were added. Figure 1.4 shows the present NTS location bounded on three sides by the Nellis Air Force Range. NTS encompassed about 1,350 square miles in 1975. This testing location was selected for both safety and security reasons. The arid climate, lack of industrialization, and exclusion of the public from the Nellis Air Force Range resulted in a very low population density in the area around NTS.

The only paved roads within the NTS and Nellis Air Force Range complex were those constructed by the government for access purposes. NTS testing areas were physically protected by surrounding rugged topography. The few mountain passes and dry washes where four-wheel drive vehicles might enter were posted with warning signs and barricades. NTS security force personnel patrolled perimeter and barricade areas in aircraft and vehicles. Thus, unauthorized entry to NTS was difficult, and the possibility of a member of the public inadvertently entering an NTS testing area was extremely remote.

Figure 1.5 shows the NTS, its various area designations, and the locations of the six test events covered by this volume. In

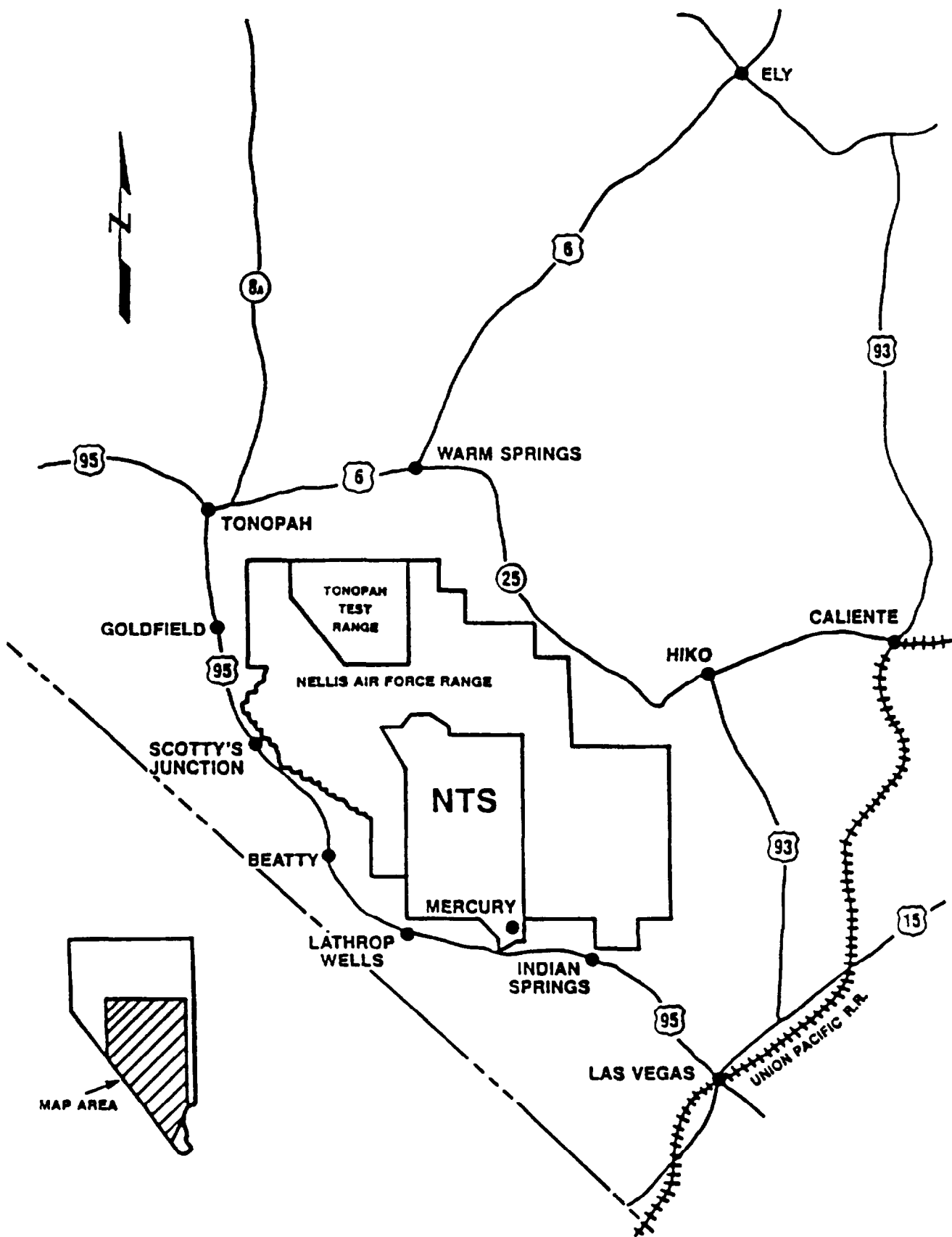

Figure 1.4 Nellis Air Force Range and NTS in Nevada.

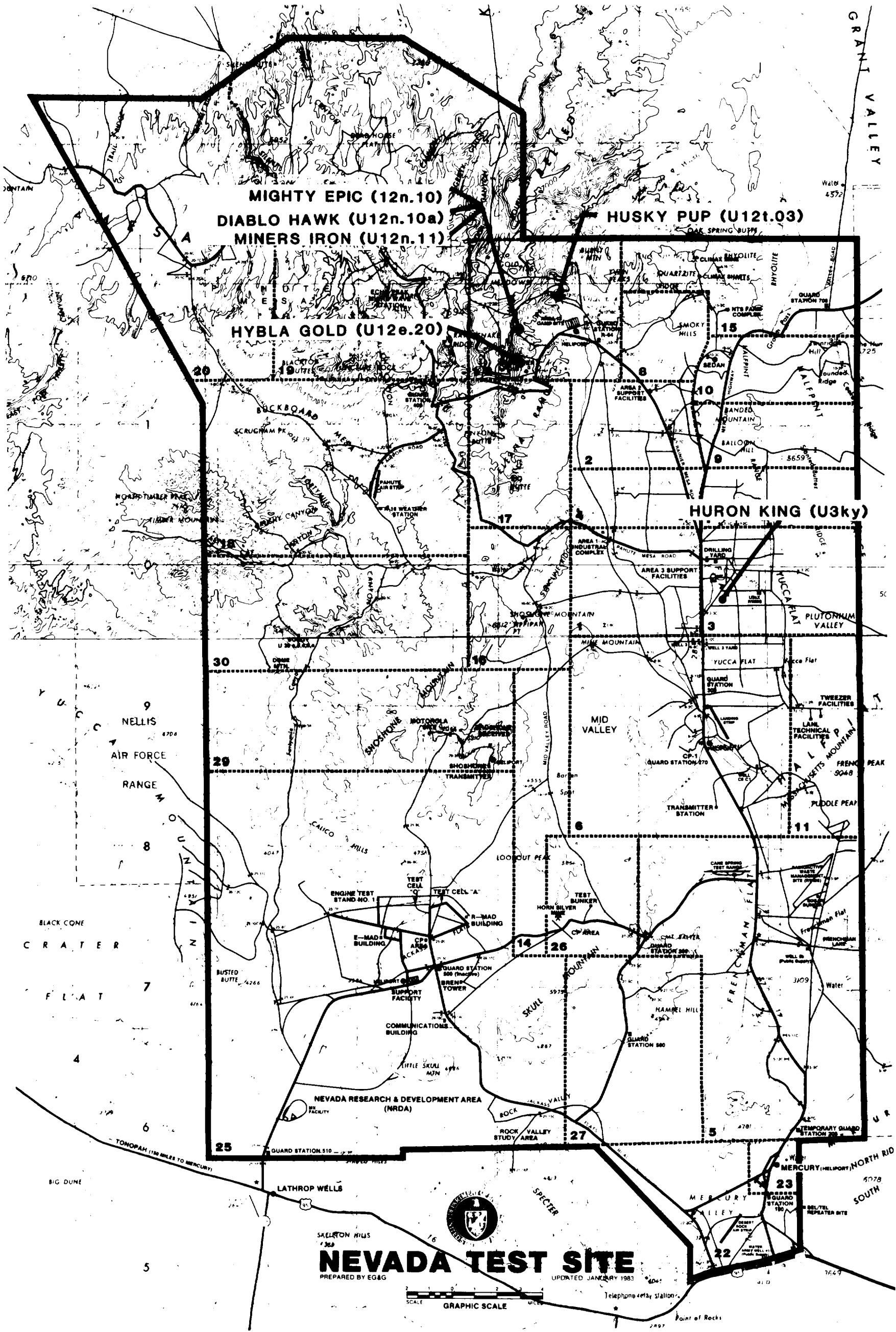

Figure 1.5 The Nevada Test Site.

a location designation such as "U12n.07," the "U" signifies an underground location, "12" identifies the area at the NTS, "n" denotes the tunnel, and "07" indicates the drift number.

A low mountain range separated the base camp, Mercury, from the location of early AEC and DOD atmospheric tests at Frenchman Flat in Area 5. This area also was later used for DOD underground testing. The elevation of Frenchman Dry Lake in the middle of the Flat is about 3,100 feet.

A mountain pass separates Frenchman Flat from Yucca Flat testing areas. The pass overlooks both Frenchman and Yucca Flats and contains the CP complex of buildings including Control Point Building 1 (CP-1) where timing and firing for most atmospheric tests were performed, and Control Point Building 2 (CP-2) where radiological safety support was based.

Yucca Flat testing areas include Areas 1, 2, 3, 4, 7, 8, 9, and 10. Underground tests were conducted in some of these areas and generally were shaft emplacement types. The elevation of Yucca Dry Lake at the south end of Yucca Flat is about 4,300 feet. To the west of Yucca Flat, in another basin, is the Area 18 testing location. Some DOD atmospheric tests were conducted in Area 18, and one DOD cratering event, DANNY BOY, was conducted on Buckboard Mesa in this area at an elevation of about 5,500 feet. Area 16 is in the mountains west of Yucca Flat toward Area 18.

The single Area 16 tunnel complex (at an elevation of about 5,400 feet) was a DOD underground testing location.

Rainier Mesa is in Area 12, northwest of Yucca Flat. The top of the Mesa is at an elevation of about 7,500 feet. All DOD tunnel-type emplacement events on NTS that were not in the Area 16 tunnel complex or the Area 15 shaft and tunnel complex were in Rainier Mesa and the adjoining Pahute Mesa. (Parts of T tunnel were constructed in the adjoining Pahute Mesa.) The major Rainier Mesa tunnel complexes were B, E, G, N, and T tunnels.

Area 15 is in the foothills at the north end of Yucca Flat. The deeper of the two access shafts drops 1,500 feet below the surface elevation of 5,100 feet. There were three events conducted in Area 15, all sponsored by DOD. HARD HAT and TINY TOT were discussed in DNA Report 6320F, Operations NOUGAT and WHETSTONE, while PILE DRIVER was discussed in Report DNA 6321F, Operations FLINTLOCK and LATCHKEY.

SECTION 2

UNDERGROUND TESTING PROCEDURES

Underground tests conducted at the NTS prior to 1962 were primarily for weapons-related purposes (including safety tests). These tests were controlled by the AEC and conducted by LASL or LLL. Experience gained in the area of radioactivity containment underground during these tests provided the basic concepts for development of containment plans for DOD/DNA sponsored underground nuclear weapons effects tests which followed. These DOD tests were generally more complex than earlier AEC tests and required development of new containment concepts and hardware.

A primary consideration in all underground tests was the safety of test participants and the general public, especially regarding exposures to radioactive materials. This chapter discusses, in general terms, containment problems and procedures, types of emplacement, diagnostic techniques, area access requirements, industrial and radiological safety, and radiation measuring systems.

2.1 CONTAINMENT PROBLEMS AND PROCEDURES.

Completely containing radioactive material underground while accomplishing diagnostic measurements and effects experiments proved to be a major engineering challenge. Original efforts considered only detonation containment in competent rock formations. It was necessary to modify the original efforts to consider zones of weakness in rock caused by faults and containment failures resulting from diagnostic and experiment structures. Under certain conditions, particularly the presence of clay or a high water content in rock formations near the detonation point, greater than normal stresses could be generated which could adversely affect containment. Some containment failures were partially attributable to additional overpressure from secondary gas

expansion, i.e., steam pressure. The major containment features and problems that evolved are discussed below.

2.1.1 Vertical Shaft Containment.

Some of the first shaft-type safety experiments were in unstemmed shafts with concrete plugs penetrated by cable and instrumentation holes. When nuclear yields were produced, these emplacements did not completely contain the radioactive debris. The first method used to fully contain nuclear detonations in shafts was stemming, e.g., filling the shaft with aggregate and sand after device emplacement.

Keyed concrete plugs at different depths in the shaft stemming sometimes were used. The shaft diameter was enlarged at the plug construction location so the poured concrete plug would key into the ground surrounding the shaft and provide more strength against containment failure. Combinations of concrete and epoxy were used later, and epoxy replaced concrete as a plug material for some shaft-type emplacements.

Radiochemical sampling pipes, LOS pipes, and other openings in stemming and plug containment features had to be closed rapidly after detonation to prevent venting of radioactive effluent to the atmosphere. Closure systems driven by high explosives or compressed air were developed to seal the openings. After some of these early systems did not prevent releases of effluent to the atmosphere, use of openings to the surface for diagnostic or experiment purposes was discontinued for several years until technology improved.

Some scientific and other cables from the device emplacement to the surface were another source of containment problems. While these cables could be embedded in concrete and epoxy, which helped prevent leakage along the outside of the cables, radioactive gases under high pressure traveled along the inside of cables as a conduit to the surface. This problem was solved by embedding the inner components of these cables in epoxy at

appropriate locations (such as in concrete plugs) in a technique called gas blocking.

The most serious containment problems were caused by unanticipated geologic and hydrologic conditions at particular test locations. Even careful and rigorous calculations, engineering, construction, and preparations were inadequate when the presence of a geologic zone of weakness above the detonation point was unknown.

Another similar problem was the presence of higher water content than anticipated in rock formations surrounding or near the detonation point. This problem caused greater shock transmission plus secondary gas expansion when the water turned to steam. In addition, presence of sufficient iron in the test configuration caused the disassociation of water with subsequent greater secondary gas expansion from hydrogen gas. A result was much higher and longer sustained pressure from the detonation point toward the surface and the possibility of subsequent failure of geologic or constructed containment mechanisms.

Recognizing and understanding geologic and hydrologic conditions at each test location was necessary before these containment problems could be solved. As additional information became available through drilling and intensive geologic studies, these problems were lessened by investigations of proposed detonation locations and application of detailed site selection criteria.

2.1.2 Tunnel-Type Containment.

As with shaft-type detonations, containment methods used for tunnel events were designed keeping the basic characteristics of a nuclear detonation in mind. Tunnel configurations were constructed with device emplacements strategically located to cause sealing of the access tunnel by force of the detonation. Additional containment features were used to contain radioactive debris.

One of the original user laboratory stemming configurations consisted of one or more sandbag plugs installed a short distance from the projected self-sealing location toward the tunnel entrance (portal). Two plugs, each about 60 feet in length, were a typical installation. The sandbag plugs were later changed to solid sand backfill plugs extending several hundreds of feet from the device location. In many cases, the sand stemming had short sections of air voids between the plugs. Closer to the portal, a keyed concrete plug with a metal blast door was constructed. The blast door was designed to contain any gases (with pressures up to 75 pounds per square inch [psi]) that might penetrate the sandbag plugs.

Also as with shaft-type detonations, the unknown presence of undesirable geologic and hydrologic conditions sometimes caused venting of radioactive effluent either through the overburden (ground above the tunnel) to the surface, through fissures opened between the detonation point and the main tunnel, or through the plugs and blast door to the main tunnel vent holes and portal. More substantial containment features evolved as containment problems became better understood and tunnel events became more complex.

The first DOD tunnel test was MARSHMALLOW (1962). Stemming for that event consisted of four sandbag plugs extending out to a distance of a few hundred feet from the nuclear device (similar to earlier AEC-sponsored tunnel events). A gas seal door (blast door) was installed in the main access drift. The next DOD tunnel test (GUMDROP, 1965) used sand backfill (with a few air gaps) out to a few hundred feet. As DOD tunnel testing continued, sand plugs gradually were replaced with various grout mixtures. Some grout mixtures were designed to match the strength and shock propagation of the native tunnel material (usually ash-fall tuff) while other grout mixtures were designed to be weaker and form a solid stemming plug shortly after device detonation.

Also, as tunnel testing continued, the gas seal (blast) door no longer was used as a containment device. It was replaced by strong concrete plugs 10 to 20 feet long. These plugs were keyed

into the tunnel wall and were designed to withstand overpressures up to 1,000 psi. Some of the plugs were penetrated with electrical cables and steel pipes, and a small access hatch was constructed. All of these penetrations were gas sealed (or capped) to provide protection against possible gas seepage through the plug.

Use of horizontal line-of-sight (HLOS) pipes in tunnel events necessitated development of additional closure systems. The HLOS pipe tunnel and its access tunnels generally were separated from the main tunnel by one or more concrete plugs. These closure systems primarily were for protection of the experiments inside the HLOS pipe, but they also were considered useful features for the formation of a stemming plug.

The tunnel volume outside of the pipe was filled by stemming or grouting, while the experiments inside the HLOS pipe were protected by mechanical closure systems. Various closure systems were used, including compressed air or explosive-driven gates and doors which closed off the HLOS pipe from the detonation within a small fraction of a second after detonation time. One of these mechanical closures was the tunnel and pipe seal (TAPS) unit, first used on the DOOR MIST event. The TAPS was a heavy steel door that was released at shot time and fell to the closed position in less than one second.

Gas blocking techniques similar to those used in shaft events were used to prevent leakage of radioactive gases along or through cables from the diagnostic and experiment locations to the surface. Additionally, a gas seal door usually was installed in the main drift nearer the portal than the concrete plug. Utility pipes, such as for compressed air, that passed through stemming and plugs also were sealed by closure systems.

2.1.3 Containment Evaluation Panel.

When containment problems were particularly difficult, the AEC began to change its emphasis on conditions under which nuclear detonations should be conducted.

The Manager, AEC/NVOO had primary responsibility for the underground containment of radioactivity from underground tests. Containment of DOD tests was a joint effort on the part of AEC, DOD, and contractor scientists and engineers. To carry out this responsibility, on 17 December 1963, AEC/NVOO established a Test Evaluation Panel (TEP) to review plans for each test as presented by user testing organizations for each test program. The chairman of this panel represented the Manager, NVOO, and membership consisted of two representatives (one voting member plus an alternate) from each of the user testing organizations (LASL, LLL, SLA, and FC/DNA) plus specialists from contractor and other government organizations such as the U.S. Geological Survey (USGS). Other AEC/NVOO contractor personnel were available to present information in their areas of expertise (e.g., mining and drilling operations).

On 19 March 1971, while testing was suspended because containment failure had caused serious venting of a laboratory test (BANE BERRY event), the TEP was changed to the Containment Evaluation Panel (CEP). The CEP was instructed to give increased emphasis to containment of radioactive materials, and the panel membership was enlarged by the addition of a hydrologist, a scientist with expertise in underground nuclear phenomenology (both selected by the Manager, NVOO), and advisors from consultants representing additional areas of expertise. These permanent advisors were representatives of the EPA, the National Oceanic and Atmospheric Administration's Air Resources Laboratory (NOAA/ARL), and REECo. Each underground testing organization was represented as before.

Prior to a formal meeting of the CEP, each user planning a nuclear test prepared written documents describing its proposed tests with particular emphasis on containment considerations and submitted these documents to each panel member for review. This information then was presented by the users to the CEP, generally at the following meeting. (Meetings were held about ten times a year.) Details of the containment plan were reviewed and comparisons to previous successful experiences were reviewed by the

CEP. Each CEP member (or alternate) was requested to submit a written statement describing the details considered favorable or unfavorable to successful containment.

During the period covered by this report, evaluations to estimate the probability of successful containment conformed to specific guidance from the DMA or OMA (depending on the date of the test) at Headquarters, DOE. Each CEP member used this guidance to categorize each test as one of the following:

CATEGORY A

Considering all containment features and appropriate historical, empirical, and analytical data, the best judgment of the member indicates a very high confidence in successful containment.

CATEGORY B

Considering all containment features and appropriate historical, empirical, and analytical data, the best judgment of the member indicates a lesser but still adequate degree of confidence in successful containment.

CATEGORY C

Considering all containment features and appropriate historical, empirical, and analytical data, the best judgment of the member indicates some doubt that successful containment will be achieved.

CATEGORY D

Unable to categorize.

A written report on each CEP meeting, containing the statement of each panel member and consultant, was forwarded to DOE/HQ for review and recommendations for approval to execute each event.

2.1.4 Test Controller's Advisory Panel.

Careful consideration of each test event by the CEP to avoid releases of radioactive effluent to the atmosphere was followed by additional precautions prior to test event execution. If an unanticipated release of effluent from an underground detonation occurred, it was necessary to assure protection of onsite participants and the offsite population. The Test Controller's Advisory Panel was composed of a scientific advisor and representatives from each organization which could contribute information to this protection goal.

This panel met at readiness briefings in advance of each event and in the Control Room prior to and during execution of each event. Panel members briefed the Test Controller's representative on aspects of test activities and meteorological conditions which he considered in his decision on whether a test should be conducted. Information presented by the panel included the status of test participants in the test area. Permission to arm and detonate the nuclear device was not given until all participants (other than those at approved manned stations) were clear of the controlled test area.

Weather conditions were considered in detail. Wind speeds and directions at increasing altitudes above ground were measured with weather balloons at stations around NTS, both preceding and during each test, to calculate and present information on where an unanticipated release of effluent might be transported off the NTS and what the levels of radiation might be in the predicted effluent cloud directions.

Actual locations of population centers, each dairy cow, and numbers of people at ranches and mines in the projected effluent cloud directions were presented and evaluated. EPA personnel in the offsite areas notified mining people to be above ground for safety purposes at the anticipated detonation time of tests which might cause a ground shock hazard. This information and numbers of people who might need to be advised to stay under cover or be

evacuated were presented for consideration. EPA personnel started offsite air samplers and placed radiation dosimeters in offsite locations before detonation time. Readiness information included capability for advising state officials to institute a milk diversion program if cattle feed or milk might become contaminated, and to replace milk and dry feed for localized family dairy cows.

The status of standby aircraft for effluent cloud sampling and tracking capability was presented. Communications between offsite weather stations and EPA personnel were checked to assure proper operation.

Radsafe personnel onsite assured that remote radiation monitoring stations in the test area and in other NTS areas were functional. Data from these stations, the weather stations, offsite EPA personnel, and personnel clearing the test area were displayed in the Control Room for continued visual examination by the Test Controller and the Advisory Panel. In addition, closed-circuit television cameras were operational in the test area on the ground and in helicopters to detect any visual indications of possible effluent release and provide capability for immediate response action by the Test Controller and the Advisory Panel members.

If the Test Controller decided that the projected effluent direction was close to populated areas, or weather conditions were not stable enough to determine the direction of any released effluent after detonation, the approval to arm and detonate was not given, and the test was either postponed for another day or placed on hold until conditions were favorable.

Conditions were considered favorable when (1) projected effluent direction was toward sparsely populated areas, (2) weather conditions were relatively stable, (3) EPA personnel could contact the few residents in the projected effluent direction and advise them of protective action to be taken, and (4) impact on milk supply from dairy cattle would be minimal. In addition, all essential equipment, personnel, and procedures were

required to be in readiness status or had been activated before permission to arm and detonate was given.

Permission to arm usually was given at least two hours before detonation to allow time for arming, securing of the test configuration and containment systems, and departure of the arming party from the test area. The detonation, however, could be delayed at any moment up to detonation time, or postponed until another day when conditions might be more favorable.

The Test Controller and the Advisory Panel received information, watched visible displays, and communicated with their field personnel up to and after detonation for a sufficient time to assure that venting had not occurred. Remote radiation detection instrument readings and closed-circuit television of the test area were monitored to detect any indication of effluent release.

When all other indications of venting were negative and the Test Controller decided personnel could approach the test location, (e.g., subsidence craters had formed for shaft-type detonations, and cavity collapse had occurred for tunnel-type emplacements, as indicated by geophones) initial radiation survey teams entered the test area to assure that effluent had not been released or that any radiation levels were low enough for experiment data recovery to begin. For tunnel-type tests, reentry of the tunnel itself (after initial survey of the surface areas, recovery of data, and approval by the DOE Test Controller) was a matter for separate and careful consideration by the Test Group Director and radiological safety personnel.

2.1.5 Effluent Release Procedures.

If radioactive effluent was released from an underground test event, established procedures were initiated in accordance with AEC NTSO SOP Chapter 0524, "Radiological Safety" (see Appendix D). Immediately upon detection of possible venting and effluent release after a detonation, the following procedures were initiated:

- A. For some tests, Radsafe survey teams were at manned stations in the test area. These teams were released to make radiation measurements to be used in determining direction and radiation levels of radioactive effluent.
- B. Aircraft were standing by to sample and track the effluent. Data reported were used to further refine information on effluent direction and radioactivity concentrations.
- C. EPA monitors in offsite areas, previously stationed in the projected path of any released effluent, were advised of actual effluent direction and radioactivity measurement data and directed to move sampling and dosimeter equipment, perform ground radiation surveys, and notify residents and workers in the effluent path of any necessary precautionary measures, such as remaining in buildings or evacuating the area temporarily.
- D. Capabilities were held in readiness to advise state officials to implement a milk diversion program. If this was necessary, Nevada and neighboring state officials could be advised to impound and replace milk supplies possibly contaminated through the cattle feed pathway, and hold impounded milk for decay of the probable contaminants (radioiodines) before using it for other purposes. On a localized basis, EPA personnel were ready to replace family dairy cow milk with fresh milk, and analyze milk for concentrations of specific radionuclides. Dry feed supplies also could be replaced for family dairy cattle if required.
- E. Capabilities were in readiness for thyroid monitoring of offsite individuals possibly exposed to radioiodines from the effluent. These mobile monitoring stations could be used in the offsite areas for screening measurements to determine if any offsite residents or workers exhibited thyroid radioactivity and should be

transported to Las Vegas facilities for more precise thyroid measurements and dose assignment.

Each of the above procedures was established to avoid or minimize exposure of the offsite population and maintain any such exposures below the radiation protection standards for individuals and population groups in uncontrolled areas, as established in AEC NTSO SOP Chapter 0524, "Radiological Safety" (see Appendix D).

While the above procedures were initiated, additional onsite procedures also were implemented. Radsafe survey teams, when released by the Test Controller, surveyed the test area in sufficient detail to plot gamma radiation isointensity lines on NTS maps and provide specific intensity measurements at experiment stations on the surface and at other locations of interest. These data were used by the Test Controller in releasing personnel to enter radiation areas in the controlled area and by the Test Group Director in determining when surveys of his immediate test area and recoveries of experiment data could be accomplished. These decisions were based on calculations of personnel gamma radiation doses from survey data, radiation intensities at recovery locations, and estimated times in area to assure that exposures would be limited only to those necessary and below the standards established in AEC NTSO SOP Chapter 0524.

Some tunnel-type tests that did not result in venting of radioactive effluent to the atmosphere did have a failure of the containment system within the tunnel. High radiation levels then existed in locations where reentry personnel needed to enter to accomplish data recovery. Procedures developed to minimize exposures of reentry and recovery personnel included the placement of remote radiation detectors located at strategic tunnel complex locations, remote tunnel atmosphere samplers that removed tunnel air to locations outside the tunnel for analysis, and tunnel air filters that would allow ventilation of tunnels before reentry with only controlled gaseous radionuclide releases to the atmosphere.

Remote monitoring and sampling equipment provided information on radiation levels, toxic gases, and explosive mixtures necessary to determine whether tunnel ventilation should be accomplished before reentry. Tunnel ventilation filters stopped particulate radioactivity and activated charcoal in the filters absorbed most of the radioiodines, thus allowing primarily only radionuclides of the noble gases, such as xenon, to be released to the atmosphere. (Exposure to radionuclides of the noble gases is far less hazardous than exposure to other fission products.) Release of this radioactive material to the atmosphere in a gradual, controlled manner during tunnel ventilation to protect reentry personnel was subject to approval by the Test Controller.

2.2 EMPLACEMENT TYPES.

The DOD conducted six underground nuclear tests which are covered in this report period. Table 2.1 lists the six events and pertinent data. There were five tunnel-type DOD tests during Operations ANVIL, CRESSETT, and GUARDIAN, and one shaft-type event during Operation TINDERBOX. Both emplacement types are discussed in this section. An emplacement type not discussed in this volume was one that resulted in the excavating or ejecting of material from the ground surface to form a crater (see Crater Experiment in the Glossary of Terms). A DOD cratering event, DANNY BOY, was conducted in 1962 during Operation NOUGAT (see DNA 6320F).

2.2.1 Vertical Shaft-Type Emplacement.

A vertical shaft-type nuclear detonation was intended to be contained underground. The shaft was usually drilled, but sometimes mined, and it may have been lined with a steel casing or have been uncased. The nuclear device was emplaced at a depth calculated to contain the explosion. At detonation time, a cavity was formed by vaporized rock. Pressure from the hot gases in the cavity held surrounding broken rock in place until the cavity area cooled sufficiently to decrease pressure. As broken

Table 2.1. DOD test events - 24 October 1975 through 31 October 1980.

OPERATION	ANVIL		CRESSET		TINDER-BOX	GUARD-IAN
TEST EVENT	HUSKY PUP	MIGHTY EPIC	HYBLA GOLD	DIABLO HAWK	HURON KING	MINERS IRON
DATE	24 Oct 75	12 May 76	1 Nov 77	13 Sep 78	24 Jun 80	31 Oct 80
LOCAL TIME (hours)	1011 PDT	1250 PDT	1005 PST	0815 PDT	0810 PDT	1000 PST
NTS LOCATION	U12t.03	U12n.10	U12e.20	U12n.10a	U3ky	U12n.11
TYPE	Tunnel	Tunnel	Tunnel	Tunnel	Shaft	Tunnel
DEPTH (FEET)	1,142	1,306	1,263	1,273	1,050	1,306
YIELD*	Low	Low	Low	Low	Low	Low

*LOW INDICATES LESS THAN 20 KILOTONS

rock fell into the cavity formed by the detonation, a chimney was formed. If the chimney of falling rock reached the surface, a subsidence crater was formed. Figure 2.1 shows a typical subsidence crater.

If a device was emplaced too deeply in the alluvium of Frenchman or Yucca Flat for the detonation yield, or the depth was correct but the yield was much less than anticipated, a subsidence crater might not form; that is, the chimney might not reach the surface. This was a problem during early years of underground testing when it was necessary to move drill rigs into subsidence craters soon after tests for cavity sample recovery purposes. If a subsidence crater did not form, drill rigs could not be moved to surface ground zero (SGZ). When directional drilling from outside the crater was implemented, lack of a subsidence crater in alluvium became less of a problem. Experience gained with depth of device burial also reduced the chance of subsidence craters not forming in the alluvium.

Most vertical shaft-type underground tests conducted by DOD included a vertical line-of-sight (VLOS) pipe system to the surface and a mobile tower on the surface that contained the weapons effects experiments (see Figure 2.2). The VLOS pipe system contained several mechanical closures designed to prevent the release of radioactivity into the atmosphere. These closures were open at the time of detonation but closed within milliseconds to stop the flow of material up the pipe. The open volume between the VLOS pipe and the wall of the drill hole was filled with sand and other materials. One or more non-porous material plugs were placed around the pipe. Electrical cables which went downhole were gas blocked to prevent gas seepage to the surface. Effects experiments were contained in a mobile tower on the surface that was moved away from the hole after device detonation but before surface collapse (formation of the subsidence crater). One problem was the possibility of seepage after surface collapse if some pathway to the surface developed. Some radioactive effluent was released into the atmosphere during several VLOS-type DOD tests.



Figure 2.1 A typical subsidence crater.

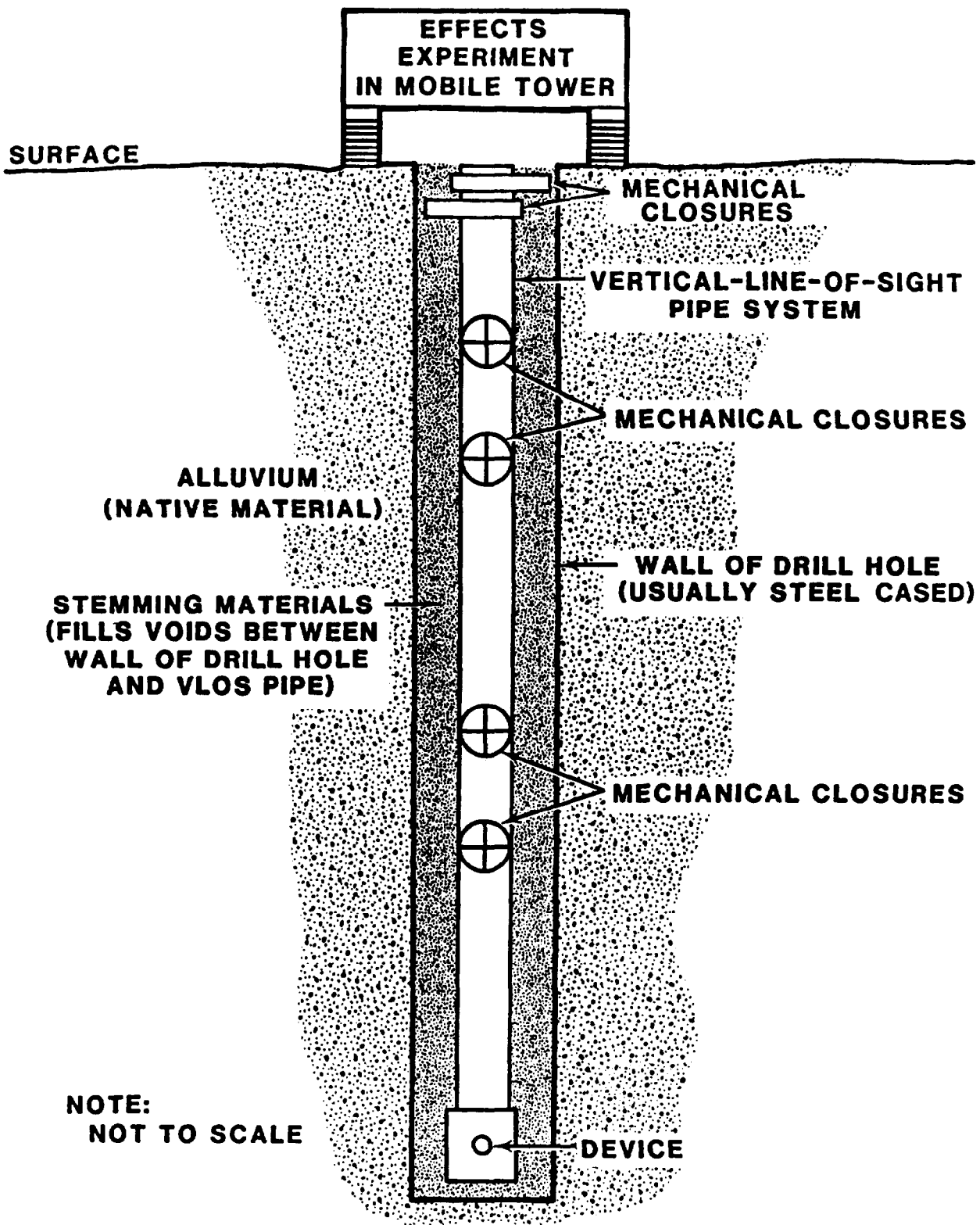
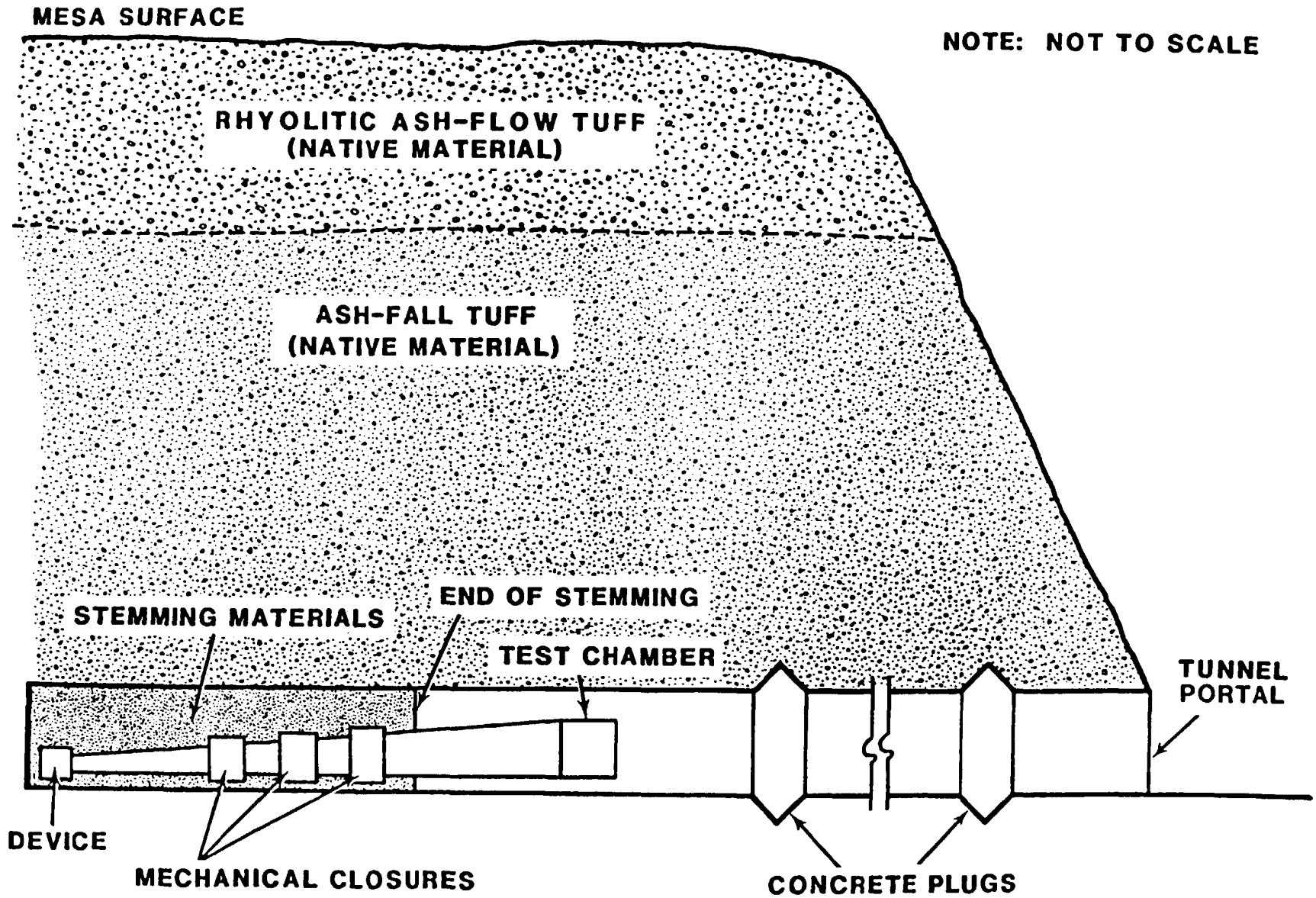

Figure 2.2 Vertical LOS pipe configuration.

2.2.2 Tunnel-Type Emplacement.

Tunnel-type emplacement nuclear detonations were intended to be completely contained. The nuclear device was emplaced in a mined drift (tunnel) at a depth designed to contain the detonation. The native material at tunnel elevation was ash-fall tuff for events covered in this volume. Chimneying of broken rock to the surface was rare, primarily because there was a layer of welded rhyolitic ash-flow tuff at and below the surface of Rainier Mesa. This tuff has a higher density than ash-fall tuff and is more competent (has more strength) than the alluvium material in Frenchman and Yucca Flats. Tunnel-type emplacements were in one of several configurations: at the end of a single horizontal tunnel into a mountain or mesa, at the end of a drift (tunnel) within a tunnel complex, at the end of a horizontal tunnel driven from a vertical shaft, or in a cavity mined from a horizontal tunnel or vertical shaft.

During the period covered by this volume, four of the five tunnel-type emplacements included HLOS pipe systems placed in horizontal drifts in tunnel complexes (see Figure 2.3). Each device was placed close to the end of a drift inside a tunnel complex. An HLOS pipe system, including several mechanical closures and one or more test chambers (which contained effects experiments), were installed in the drift. The mined area surrounding the HLOS pipe was filled (stemmed) with various mixtures of grout to a distance of several hundred feet from the device location. This closure of the tunnel in the stemmed area was the primary containment system. Ground shock and expansion of the gaseous cavity material exerted pressure on the tunnel walls and stemming materials to form a stemming plug, closing the tunnel and HLOS pipe immediately after detonation. All electrical cables and other penetrations within the stemmed area were gas blocked carefully to prevent or minimize seepage of radioactive gases through the stemming plug. The mechanical closures in the HLOS pipe were designed primarily to protect the effects experiments; however, they also had some effect on the formation of the stemming plug. The secondary (or backup) containment system included two or more concrete plugs, which



44

Figure 2.3 Horizontal LOS pipe configuration.

were strategically keyed into the tunnel walls to prevent leakage of radioactive gases outside the tunnel should the primary system fail. These concrete plugs were designed to withstand the maximum expected pressure and temperature.

DNA has led the development of tunnel containment systems and has maintained continuing research and development programs to improve containment of tunnel events.

2.3 DIAGNOSTIC TECHNIQUES.

The transition from atmospheric to underground testing substantially reduced the release of radioactive materials to the atmosphere, and required the development of new device diagnostic techniques. During atmospheric tests, high-speed photography recorded fireball growth and aircraft collected samples from the radioactive cloud for diagnostic measurement analysis. Because such systems could not be used on underground tests, several new diagnostic techniques were developed (some of which are discussed in the following subsections).

2.3.1 Radiation Measurements.

Measurements of radiation from an underground detonation were made possible by the development of a system of remote detectors and cabling that sent signals to recording facilities located at the surface. Detectors, utilizing various physical characteristics of the radiations to be measured, were installed near the nuclear device. High-specification coaxial cable and connectors carried the measurement signals to the surface where electronic equipment, film, and magnetic tape recorded the signals or transmitted the signals by microwave to CP.

The detector signals were on the way to recording equipment billionths of a second after a detonation, before the detectors were destroyed. These measurement systems required the most advanced electronic technology available. Considerable research and development were necessary to acquire and refine these capabilities.

2.3.2 Radiochemical Measurements.

Because clouds from atmospheric detonations no longer were available to sample for diagnostic purposes, techniques were developed to obtain samples of debris from underground detonations for radiochemical analyses and subsequent yield determinations. The first systems were radiochemical sampling pipes leading directly from the device emplacements to filtering equipment at the surface. These pipes required closure systems to prevent overpressure from venting radioactive effluent into the atmosphere after samples were collected.

While these systems functioned as intended for most detonations, the systems did not function properly during all tests, and some radioactive effluent was released into the atmosphere. Subsequently, routine use of radiochemical sampling pipes to the surface was discontinued for a time until technology improved.

A major radiochemistry sampling method which continued in use for shaft and tunnel detonations was postevent core drilling. The objective of this drilling was to obtain samples of solidified radioactive debris which had collected in a molten pool at the bottom of the cavity produced by the detonation. This method required and resulted in the development of precise directional drilling techniques and several advancements in the sciences of core drilling and radiochemical analysis.

2.4 EFFECTS EXPERIMENTS.

DOD/DNA events were conducted primarily to obtain nuclear weapons effects data. The effects of blast, shock, and thermal and nuclear radiations had been investigated earlier during atmospheric and underwater tests. Military equipment, structures, and materials had been exposed to various nuclear effects. The transition to underground testing required development of new test techniques. One important new technology was simulation of

high altitude (to exoatmospheric) conditions for radiation effects experiments.

This simulation technique involved placing experiments inside test chambers and providing a low-pressure atmospheric condition from the nuclear device to the experiments. This was achieved by using large vacuum pumps to reduce pressure inside the steel LOS pipe to match the pressure of the desired altitude.

Experiments were categorized as passive or active (diagnostic). Passive experiments involved placing experiment equipment in test chambers, exposing the equipment to the desired nuclear environment, removing the experiment, and analyzing it to obtain effects results. Active experiments utilized various sensors and high-speed electronic recording equipment to obtain data. Many active experiments also involved recovery and analysis to obtain effect results.

2.5 TUNNEL AND DRILLING AREA ACCESS REQUIREMENTS.

Access to underground work and drilling sites was controlled for a number of reasons. During construction, safety of both workers and visitors in these locations could have been jeopardized by carelessness or seemingly harmless activities of untrained and uncontrolled workers or visitors. When security-classified materials were in these locations, only personnel with appropriate security clearances were permitted access to the area. The presence, or anticipated presence, of radioactive material in a location required access control for radiological safety purposes. Access requirements established for the above purposes are discussed below.

2.5.1 Tunnel Access Control.

During construction and preparations for a DOD event in a tunnel or other underground work site, the tunnel Superintendent was responsible to the REECO Project Manager for safety of personnel underground. From 1962 forward, Radsafe and tunnel log-books usually were used to record names and radiation exposure

information for only those persons entering a tunnel during postevent reentry and recovery operations. In the early 1970s, as a result of the Mine Safety and Health Act, tunnel logbooks were expanded to list all persons entering the tunnels (i.e., visitor, mining, drilling, Radsafe, etc.). Visitors and other personnel not assigned to work in the tunnel obtained permission for entry from the Superintendent, or his representative, were apprised of tunnel conditions and safety regulations, and were listed in the logbooks. In the event of an accident or other emergency condition underground, the logbook provided information on numbers of personnel and their locations underground.

When classified material was in the tunnel prior to a test event and during initial reentry after an event, the DOD Test Group Director, or his representative, was responsible for entry and safety of personnel underground. Security personnel checked for proper security and entry clearances, maintained records of all personnel entering the tunnel, and safeguarded the device and other classified material. The check point was often well inside the portal thus allowing several activities at various work sites to be conducted simultaneously.

After detonation, aerial damage surveys to determine the accessibility of the various recovery stations were required before surface reentry operations were begun. When the reentry teams were given permission to depart Gate 300 (a check point set up in Area 3, north of the turnoff to the Control Point, also known as Guard Station 300, see Figure 1.5) by the Test Controller, radiation and industrial hygiene surveys were conducted on the Mesa and in the portal areas before any other personnel were allowed in these areas.

Before underground recovery operations were begun, a listing was made of hazardous elements whose performance degradation; functional failure; or physical, chemical, or electrical properties constituted a post-test hazard within the test system complex. General requirements and standards governing safety were based on FC/DNA Instruction 3200.5B. Hazardous elements were defined to include active experiments and/or hardware

containing radioactive, explosive, fire hazard, pressure vessel, evacuated container, electrical, toxic, and/or chemically hazardous components.

Instructions on the proper procedure, should a potential hazard have become a real hazard as a result of detonation, were made available to the underground reentry team and recovery personnel. Situations where special permissions were to be given before the tunnel reentry team would be allowed to proceed (including checking pressure and sampling gas on the zero point side of the gas seal plug, opening the overburden plug [OBP] 36-inch and 26-inch manway doors, and removing the insulation materials from inside the OBP crawl spaces) were outlined in detail prior to reentry. Each permission was given by a responsible party outside the tunnel complex on the basis of information transmitted by the reentry team. The required condition of the tunnel before experimenter personnel were allowed access to the test chamber also was outlined specifically.

Before experiments were released to the experimenters, each experiment was monitored for radioactivity and bagged (to reduce spread of contamination) as necessary inside the tunnel. Swipe samples were taken on experiments and equipment leaving the tunnel area to verify contamination standards were not exceeded. Experiments and equipment with higher than allowed removable contamination levels were sent to a decontamination area or released to the experimenter or laboratory with the understanding the item would be decontaminated and/or handled in accordance with appropriate procedures before analysis or reuse.

Control of tunnel access reverted to tunnel management personnel after tunnel reentry and recoveries. Entry procedures and use of the tunnel logbook were then implemented as discussed above.

Additional access controls were instituted for radiological safety purposes after an event or during construction and event preparation when radioactivity from a previous event could be

encountered. Part or all of a tunnel complex could be established as a radiation exclusion (radex) area.

All persons entering radex areas were logged on a form called the "Area Access Register." Names and organizations represented were listed. Radiation exposures from reports for the year and quarter were listed upon entry. Self-reading pocket dosimeter measurements were added upon exit. This was to assure that personnel approaching radiation exposure guide limits would not be allowed to enter radex areas when they could potentially accumulate exposures above guide levels.

Before entry into a radex area, personnel were dressed in anticontamination clothing and respiratory protection as needed for the particular radiological conditions in the tunnel. Upon exit, anticontamination clothing was removed, personnel were monitored for radioactive contamination, and decontamination was accomplished, if necessary.

2.5.2 Drilling Area Access Control.

Access to drilling areas was controlled by the drilling superintendent and the DOD Test Group Director for the same reasons as access to underground workings was controlled. While drilling an emplacement shaft and during postevent drillback operations to recover radioactive core samples, personnel safety and compliance with safety regulations were emphasized continuously.

During preevent drilling activities, all visitors were required to contact the drilling superintendent before entry to the drilling site. Names of visitors and the purpose of each visit were entered in the daily drilling report, and it was assured that visitors wore hard hats and understood safety regulations.

The laboratory which provided the device controlled access to the area, assisted by security force personnel, when classified materials (including the nuclear device) were brought into the area for emplacement. After the event, when the drill site

was a radex area, during classified material removal or postevent drilling, both security and radiological safety access controls were in effect as discussed under "Tunnel Access Control."

2.6 INDUSTRIAL SAFETY CONSIDERATIONS.

Implementation of an effective industrial safety program was an important part of any heavy construction operation. Mining and drilling operations had a particularly high accident potential. These operations at the NTS involved additional safety problems resulting from detonation-induced unstable ground conditions and potential for encountering toxic gases, explosive mixtures, and radioactivity.

Miles of underground workings were constructed at several locations. More depth of vertical big holes (three-foot diameter or larger) were drilled than the known total drilled in the rest of the world. Directional and core drilling to recover radioactive debris samples after underground nuclear detonations advanced the science of these drilling techniques. These operations often were accomplished under unusual conditions with accompanying difficult safety problems.

The lost-time accident frequency, however, for the NTS support contractor employing most of the NTS personnel (REECo) was only one-tenth of the frequency for the heavy construction industry at large (as determined by annual surveys and reports for 300 heavy construction corporations). This excellent safety record was attained by continuing attention to indoctrinating and training NTS personnel, investigating and determining causes of accidents at the NTS, implementing and enforcing safety regulations, and, most important, maintaining the safety awareness of NTS personnel.

Safety was a joint effort by DOE, DNA, and their predecessors, and by the many other government agencies and contractors at NTS. Administered by REECo, the safety program enjoined all NTS personnel to conduct operations safely, and was exemplified by signs at the portal of a typical DOD tunnel

complex as shown in Figure 2.4, one of which states, "Safety With Production is our Goal."

The safety procedures for all NTS operations are voluminous and cannot be included in this report. Appendix C of this volume is an example of a pertinent safety procedure: General Tunnel Reentry Procedures for Defense Nuclear Agency and Sandia Laboratories Nuclear Tests. As this procedure indicates, several aspects of industrial safety are interrelated. Information on monitoring levels of radioactivity and personnel exposures to radiation is presented in section 2.7, "Radiological Safety Procedures."

Monitoring of toxic gases and checks for explosive mixture were an important aspect of safety in underground workings, on drill rigs, and in drillhole cellars (the enlarged excavated area under the drill rig platform used for valving and other equipment). Toxic gases and explosive mixtures were created by both the nuclear detonations and the mining and drilling operations. The Draeger multi-gas detector and MSA explosimeter were available to detect such gases. The Fyrite or J&W oxygen indicator also was available to determine the oxygen content of the working atmosphere. The GPK was a combination oxygen indicator and explosimeter and was the instrument most commonly used by tunnel monitoring personnel throughout the period covered by this report. Requirements were that tunnel and drill rig breathing atmosphere contain at least 19.5 percent oxygen. During the period covered by this volume, it was required that the breathing atmosphere contain less than the levels of toxic gases and percentage of the lower explosive limit (LEL) listed below. Explosimeter instruments are calibrated with 5.6 percent methane (adjusted for atmospheric temperature and pressure) in air as 100 percent of the LEL for methane mixtures with air. Less than 100 percent of the LEL is not an explosive mixture of a gas or gases.

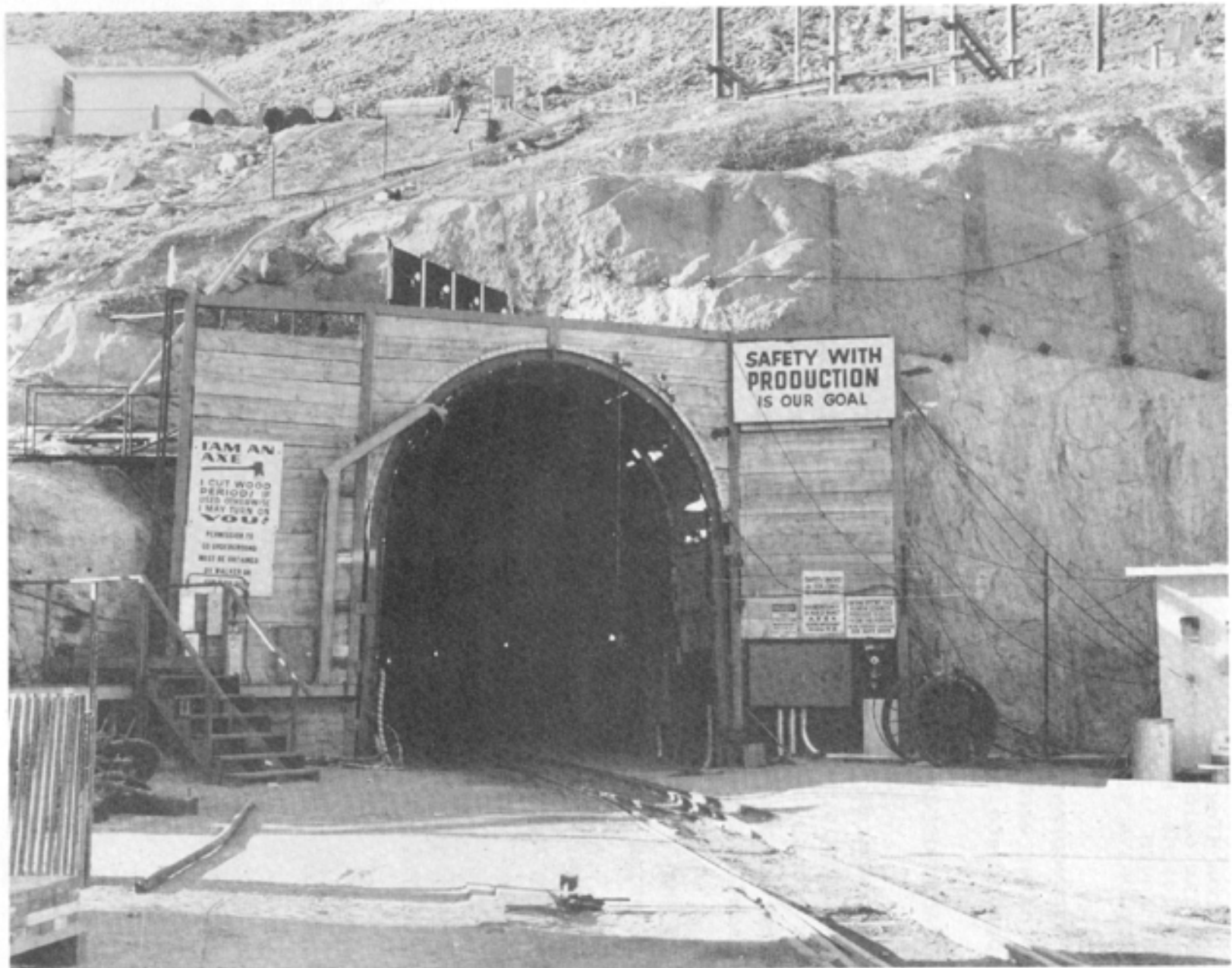

Figure 2.4 Portal of a typical DOD tunnel complex.

<u>Gases</u>	<u>Maximum Concentration</u>
Carbon monoxide, CO	50 ppm
Carbon dioxide, CO ₂	5,000 ppm
Nitric oxide plus nitrogen dioxide, NO + NO ₂	25 ppm
Nitrogen dioxide, NO ₂	5 ppm
Explosive mixtures	10% of the LEL

Procedures for controlling percentages of the LEL and toxic gases after each test event are discussed in the event chapters as appropriate.

2.7 RADIOLOGICAL SAFETY PROCEDURES.

Procedures were developed in an effort to evaluate radiological, toxic, and other hazards and to protect workers and the public from unnecessary exposures. The following were the primary written procedures and implementation methods used at the NTS from 1975 through 1980.

2.7.1 The U.S. Atomic Energy Commission, Nevada Test Site Organization - Standard Operating Procedure (NTSO SOP).*

Chapter 0524, Radiological Safety, of this procedure (which appears as Appendix D to this volume) defined responsibility and established criteria and general procedures for radiological safety associated with NTS programs. Some of the major areas discussed are film badge procedures, radiation surveys, entry into controlled areas, and radiation exposure guides. Roles of the onsite REECo Environmental Sciences Department and the offsite United States Environmental Protection Agency are defined in NTSO SOP Chapter 0524.

2.7.2 The Standard Operating Procedures for the Environmental Sciences Department, REECo.

*AEC NTSO SOP Chapter 0524 was not superseded until July 23, 1982.

These were prepared and updated annually to address in more detail the radiological safety aspects discussed in the latest revision of NTSO SOP Chapter 0524.

2.7.3 Implementation of Radiological Procedures.

The required equipment, devices, and capabilities for monitoring radiation levels in the environment and monitoring external and internal exposures of personnel are described as follows:

A. Portable Radiation Detection Equipment.

- Eberline PAC-4G (alpha)
- Eberline PAC-1SA (alpha)
- Eberline E-520 survey meter (beta and gamma)
- Ludlum Model 101 survey meter (beta and gamma)
- Hanford Cutie Pie survey meter (beta and gamma)
- Eberline Model PIC-6A (gamma)
- Eberline Model PNR-4 survey meter (fast and slow neutrons)
 - Eberline Model PRM-5 survey meter (alpha, beta, and gamma)
- Teletector Model 6112 (beta and gamma)
- FIDLER survey meter (low energy x-ray and gamma)
- Precision Model P-111 Scintillator (gamma)
- T-290 Military Air Sampler (tritium)
- Sandia/Bendix T-446 Tritium Alarm Monitor (tritium)
- Sandia NR-3 Portable Radioactive Gas Detector (tritium)

B. Air Sampling Equipment.

- Model 102 semi-portable sampler
- Satellite sampler
- Hurricane high-volume portable sampler (Gelman)
- Vacuum pump low-volume portable sampler (Gelman)

C. Laboratory Analysis Capability.

The Environmental Sciences Laboratory analyzed air, soil, water, surface swipe, nasal swab, urine, and wound swab samples for some or all of the following activities: gross alpha and beta, gross fission products, tritium, strontium-90, plutonium-239, and spectrographic analysis for specific gamma-emitting radionuclides. The laboratory also analyzed some of the above-mentioned samples for nonradioactive materials, such as beryllium, through use of an emission spectrograph and by wet chemistry procedures. A spectrophotometer was used to analyze for other materials.

D. Monitoring of Personnel Exposures.

The NTS combination personnel dosimeter and security credential holder was placed in use in 1966 to provide the increased personnel dosimetry capability necessary to meet the radiation exposure problems associated with nuclear rocket testing and underground nuclear detonations. The holder was designed to accommodate a Kodak film packet, a fast neutron packet, an identification plate, criticality accident components, the security credential, and a snap-type clip. The complete package had capabilities for determining beta, gamma, x-ray, thermal neutron, fast neutron, high-range gamma, and high-range neutron doses. Components for criticality accidents (unintentional or accidental nuclear fissioning of device critical materials) included materials which could detect and measure neutron and gamma radiation exposures above the ranges of the film packets. A Kodak Type III film packet contained two component films, one low range and one high range. Gamma exposure ranges of the two components were 30 mR to 10 R and 10 R to 800 R, respectively. The NTS combination personnel dosimeter and security credential holder is shown in Figure 2.5.

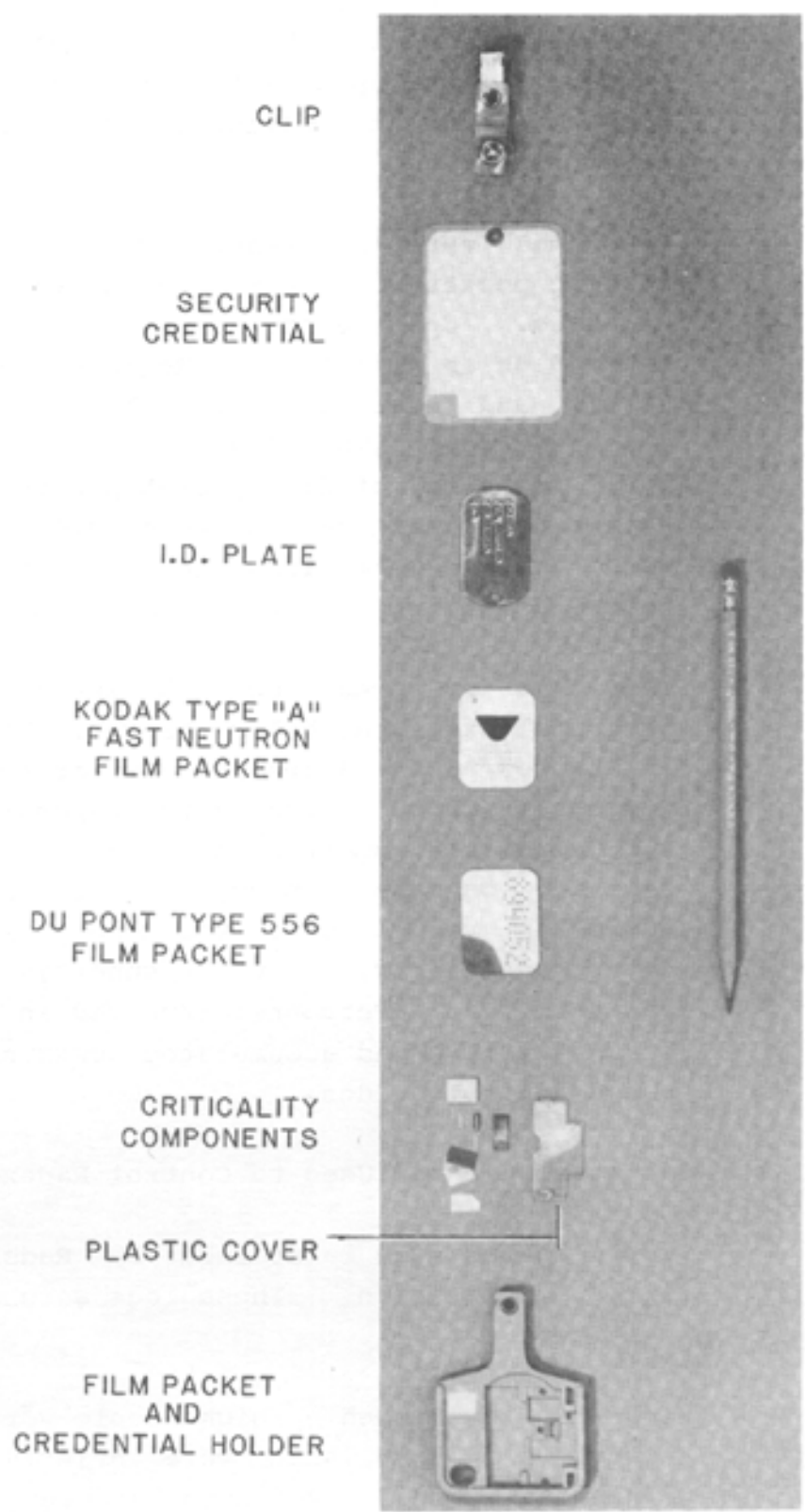

CLIP

SECURITY
CREDENTIAL

I.D. PLATE

KODAK TYPE "A"
FAST NEUTRON
FILM PACKET

DU PONT TYPE 556
FILM PACKET

CRITICALITY
COMPONENTS

PLASTIC COVER

FILM PACKET
AND
CREDENTIAL HOLDER

Figure 2.5 NTS combination personnel dosimeter and security credential holder.

Film badges were exchanged routinely each month for all individuals and upon exit from a radex area when it was suspected that an individual had received 100 mR or more of exposure.

Personnel entering radex areas also were issued self-reading pocket dosimeters which indicated accumulated exposure. Upon exit, pocket dosimeter readings were entered on an Area Access Register and added to the yearly and quarterly accumulated exposures from the automated daily NTS radiation exposure report for use until results of film packet processing were included. Pocket dosimeter readings were used as estimates because such readings were less accurate than the doses of record determined by processing film packets.

This use of Area Access Registers helped to maintain personnel exposures below the whole body exposure guides in Chapter 0524: 3 rem per quarter and 5 rem per year. Personnel whose accumulated exposure was in excess of 2,500 mrem per quarter or 4,500 mrem per year (as recorded on the exposure report plus any pocket dosimeter reading since the report) were advised not to enter radex areas, and their supervisory personnel were so notified. Personnel involved in DOD events covered by this volume had accumulated doses substantially below these control guides.

2.7.4 Additional Methods Used to Control Radex Areas.

A daily logbook was maintained by Radsafe monitors for each radex area location. These logs were used to record the following information:

- A. Work accomplished - Which people worked where and what work was accomplished were briefly described. Any unusual conditions, such as equipment failure and operational difficulties, were listed.

- B. Visitors - First and last names of visitors were entered. Their destination and the reason for their visit were included where possible. The time they entered and exited the area and results of personnel monitoring were recorded.

- C. Unusual occurrences - Any unusual events which occurred during the shift were recorded. Included in this type of entry were accidents, high-volume water seepage, or any other occurrence of an unusual nature.

- D. Surveys and samples - Information collected was recorded as follows:
 - Survey type - Routine or Special*
 - Sample type - Routine or Special*

*The requester's name was indicated for Special type.

- E. Date and signature - The date and shift were entered at the beginning of the work period and the logbook was signed before leaving the shift.

Personnel leaving radex areas removed anticontamination clothing and equipment and placed them in special containers for later laundering or disposal at the designated NTS burial site. Personnel then were monitored to assure radiation levels were below those listed in Part I of AEC NTSO SOP Chapter 0524, "Radiological Safety" (see Appendix D). Personnel decontamination was accomplished if radiation levels were above specified limits. Decontamination usually was accomplished by vacuuming, removing radioactive particles with masking tape patches, washing hands or localized skin areas with soap and water, or showering with soap and water.

Vehicles and equipment removed from radex areas were monitored to assure that they met criteria for unconditional release on or off the NTS (less than 0.4 mrad/h fixed beta plus gamma at contact and/or 1,000 disintegrations per minute [dpm] per 100 cm² of non-removable plutonium alpha; and less than 1,000 dpm/100 cm²

of removable beta plus gamma and/or 100 dpm/100 cm² of swipeable plutonium alpha). Items exceeding these limits but below radex area levels could be conditionally released and moved onsite only.

2.8 TELEMETERED MEASUREMENTS OF RADIATION LEVELS.

Beginning in the early 1960s, various applications of radiation measurement telemetry were developed at the NTS to determine radiation levels at critical underground and surface areas following nuclear detonations. Multi-detector systems with range capabilities from 1 mR/h to 1,000 R/h and from 100 mR/h to 100,000 R/h continuously monitored locations of concern after being calibrated and emplaced prior to each test event. Ion chamber detectors were hard-wire linked by telephone trunk lines to exposure rate meters at a central console in CP-2. Detector locations were as far as 35 miles from this console. In 1974, these conditioned phone lines were supplemented by portable transmission stations. The detector was hard-wired into an area trailer and the signals were sent by microwave to the Control Point.

These remote radiation monitoring systems provided data for reentry personnel participating in radiation surveys and recovery operations after each nuclear device detonation. The systems aided in substantially reducing exposure of personnel involved in reentry programs and were useful in detecting any venting or leakage of radioactive effluent to the atmosphere from an underground detonation.

2.8.1 Telemetry System in Use.

During the time period covered by this volume, radiation telemetry systems developed and used at NTS had specific applications depending upon distance, terrain, environment, and operational needs. The detection units and components in use for DOD events in this volume were part of the remote area monitoring system (RAMS). The principal piece of equipment used to form a RAMS was the RAMP-4. The RAMP-4 was a multi-channel, hard-wire

linked, remote area gamma radiation monitoring (telemetry) system, designed and modified by Radsafe and produced by Victoreen Instrument Corporation. It consisted of a probe (Figure 2.6), which used a Neher-White radiation sensing element, hard-wired to an area trailer which sent microwave transmissions to communicate with the readout console (Figure 2.7) up to 35 miles away, and terminals which provided a printout of readings at set time intervals.

The readout covered six logarithmic decades (two three-decade scales) to provide a usual range of 1 mR/h to 1,000 R/h with a relative accuracy of ± 15 percent over the temperature range of -10°F to 150°F . Extended range RAMS unit provided a range from 100 mR/h to 100,000 R/h.

A permanent array of 20 to 35 telemetry stations throughout the NTS, as designated by DOE, was maintained and operated continuously. Temporary telemetry arrays for DOD events varied between 15 and 50 stations depending upon the area or tunnel event location.

2.8.2 Remote Area Radiation Detection Monitoring Support.

Approximately 20 detector units were positioned in the test area before a shaft-type event to continuously monitor radiological conditions and assess exposure rates before the test area was entered after detonation. Detectors were placed in circular arrays at appropriate distances from surface ground zero (SGZ) which varied with device yield and predicted wind direction (See Figure 2.8). Variable numbers of detectors were used aboveground and underground during tunnel-type events. The additional 20 to 35 permanently established remote radiation detector stations operated continuously at living areas, work areas, and other locations throughout NTS (Figure 2.9). Event-related temporary telemetry detectors operated from zero time until it was determined that release of radioactivity probably would not occur, or until any released radioactivity had decayed to near-background levels at the telemetry stations. For some of the earlier events, readout locations were positioned near the



Figure 2.6 Neher-White RAMS Probe.

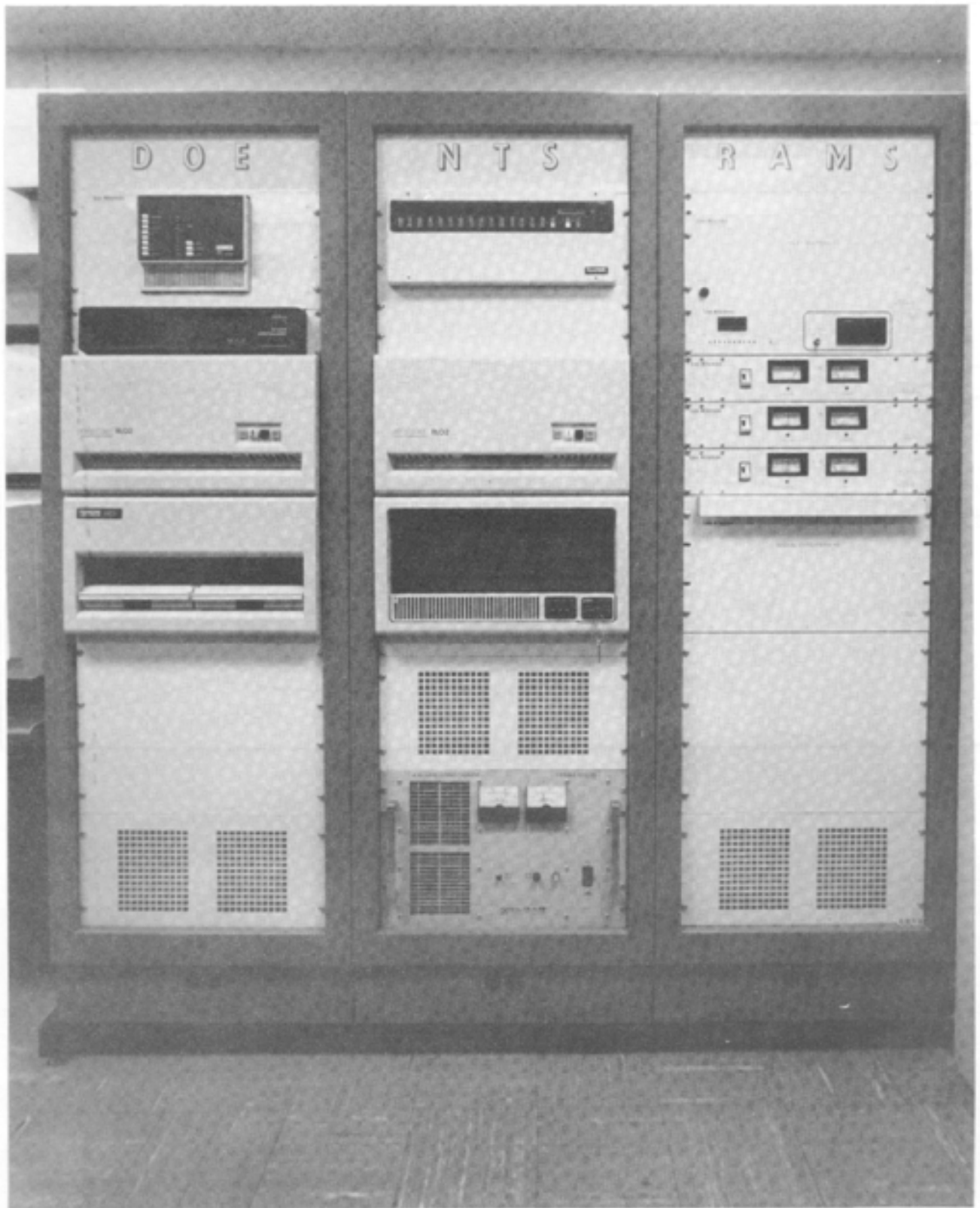

Figure 2.7 RAMS readout console.

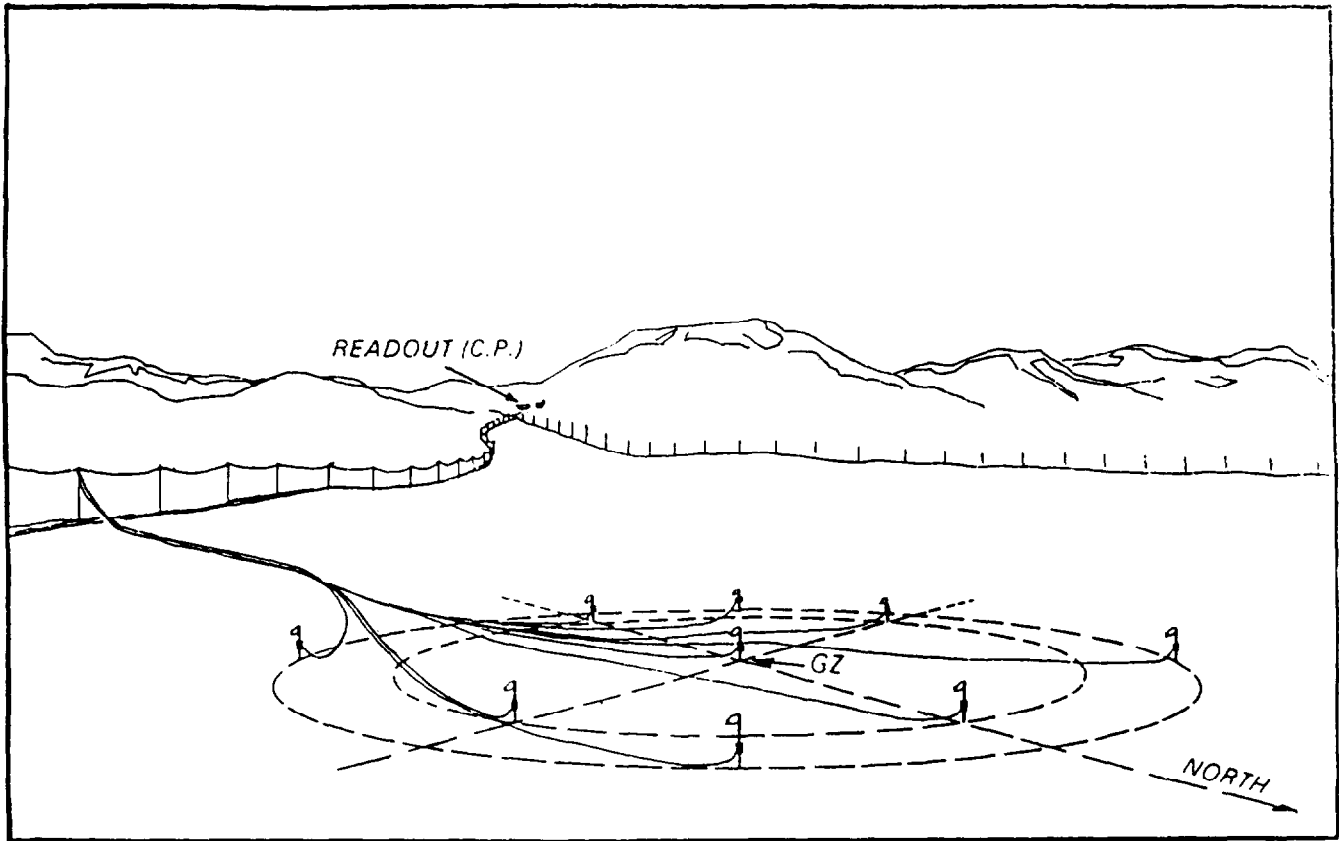

Figure 2.8 Typical remote radiation detection monitoring system for shaft-type emplacement site.

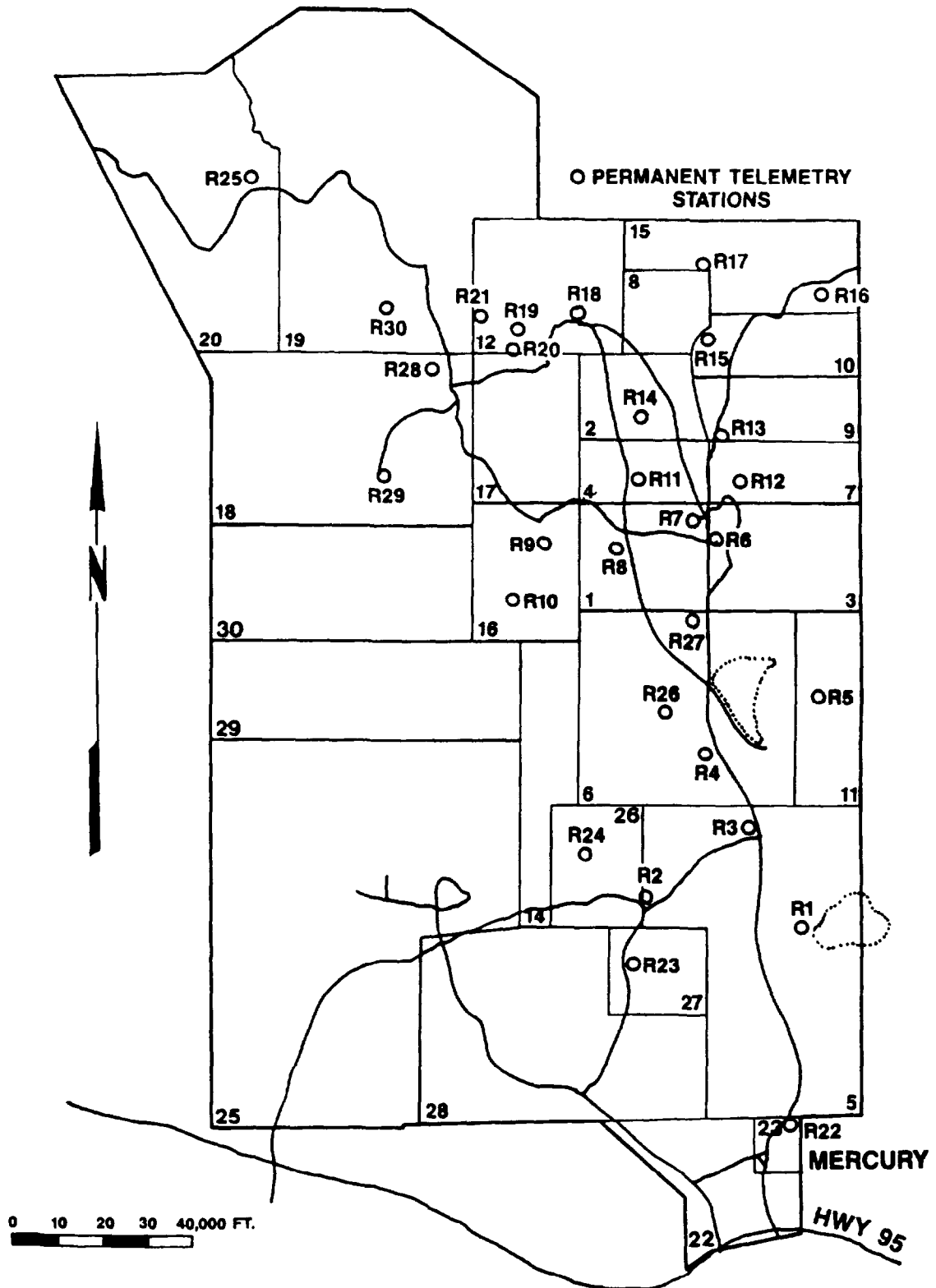

Figure 2.9 Typical permanently-established remote radiation detection stations operated continuously throughout the NTS.

forward control point (FCP) or at locations where telephone lines were available, in addition to the readouts located at CP-2.

Radiation telemetry data were supplemented with information collected through a mobile air sampling program. Model 102 air sampling units were used to obtain samples of any radioactive effluent released at event time or during the postevent drilling operations. Prior to each nuclear detonation experiment, at least one sampler was placed at a specified location in the test area and remained in position until drillback operations were completed or the Test Group Director authorized removal.

2.9 AIR SUPPORT REQUIREMENTS.

Direct support was provided to NTSO by ISAFAF for DOD underground tests, and other Air Force organizations provided support under NAFB control as described in section 1.3.2 of this volume. Less air support was required, however, as the probability of venting radioactive effluent to the atmosphere decreased with development of more effective containment techniques.

2.9.1 Changes in Air Support Requirements.

After 1962, Air Force cloud-sampling and cloud-tracking aircraft generally were not required except for cratering events conducted by the DOE where radioactive effluent clouds were anticipated. Passage of the radioactive effluent through variable amounts and temperatures of rock and other media selectively retained some radionuclides underground, and changes occurred in the fission product ratios previously used during calculation and analysis of atmospheric detonation cloud samples. The value of analyzing particulate and gaseous cloud samples to determine characteristics of a detonation decreased accordingly.

The first change in cloud sampling and tracking support was to a lighter Air Force aircraft, the U-3A, with an Air Force pilot and EPA monitor. The EPA monitor also performed aerial monitoring of selected locations near surface ground zero and along the path of any effluent cloud. This air support later was

performed by EPA and contractor personnel in their own aircraft. No radioactive effluent was detected offsite after the test events covered in this volume.

Perimeter sweeps continued to be conducted daily by Air Force and Security personnel during reasonable flying weather, to assure that unauthorized vehicles were not entering the NTS over rough terrain or around security barricades on secondary roads. Air security sweeps of the immediate test area were conducted for a few hours before each detonation to assist in clearing the test area and to assure that unauthorized vehicles were not approaching it from directions not controlled by manned security stations.

Air support for photography missions during test events and initial radiation surveys after each event did not change. Helicopters with Air Force pilots generally were used with contractor and military photographers and Radsafe monitors.

2.9.2 Radsafe Support for Indian Springs Air Force Auxiliary Field Personnel.

Radsafe support facilities had been established about 20 miles southeast of Mercury at ISAFAF during earlier atmospheric nuclear testing. REECO provided all Radsafe support functions at the NTS. This included monitoring personnel stationed at the ISAFAF Radsafe quonset facility and a complete stock of film dosimeters (badges), radiation detection instruments, and anticontamination clothing and equipment for use by air and ground crews. In 1974, after the responsibility for air support to NTS was transferred from AFSWC to the 57th Fighter Weapons Wing (see paragraph 1.3.2), helicopters continued to be supplied and manned by personnel stationed at ISAFAF. Radsafe personnel were not involved with these monitoring and photography support aircraft until they arrived at their NTS staging areas.

Radsafe monitors issued and exchanged film dosimeters (badges), issued self-reading pocket dosimeters, provided anti-

contamination clothing and respiratory protection equipment, monitored aircraft and personnel after events, decontaminated personnel, and assisted ground crew personnel with decontamination of aircraft at the NTS when necessary.

2.9.3 Radsafe Support for Helicopters.

Special helicopter Radsafe procedures were implemented for helicopters which staged from pads at the NTS, located east of Mercury Highway near the CP area and near the Test Controller's FCP established for a particular underground event. Helicopter pilots usually landed at these locations and were briefed on their scheduled or other operational missions there.

If the mission involved possible contamination of the helicopter, Radsafe monitors lined the floor of the aircraft with plastic (or kraft paper) and masking tape to facilitate decontamination. Pilots and crew members were dressed in anticontamination clothing and provided with film badges, pocket dosimeters, and respiratory protection equipment if airborne radioactive material was anticipated and oxygen masks were not worn.

Upon completion of missions, helicopters returned to the landing pads where they were checked for radiation and, if necessary, decontaminated by Radsafe monitors. Pilots and crew members were monitored and decontaminated as necessary at an adjacent forward Radsafe base station (or at CP-2) where pocket dosimeters were collected and read and film badges were exchanged if exposures of 100 mR or more were indicated by pocket dosimeters.

SECTION 3

HUSKY PUP EVENT

3.1 EVENT SUMMARY.

HUSKY PUP was a DOD-sponsored test conducted at 1011 hours PDT on 24 October 1975 with a yield of less than 20 kilotons. The device was detonated in the U12t.03 drift of the T tunnel complex (Figure 3.1) at a vertical depth of 1,142 feet. The purpose of the event was to test the response of materials and equipment to a nuclear detonation environment. Additionally, experiments were designed to characterize the interaction of nuclear burst debris with the earth's surface. An evacuated horizontal LOS pipe 951 feet long was used to house experiments. Government agencies and contractors conducted 31 projects to obtain the desired weapons effects information.

Stemming was successful and containment was complete. No radioactive effluent from this test was detected onsite or offsite.

3.2 PREEVENT ACTIVITIES.

3.2.1 Responsibilities.

Safe conduct of all HUSKY PUP project activities in Area 12 was the responsibility of the DOD Test Group Director. Responsibilities of ERDA and ERDA contractor personnel were in accordance with established ERDA-DOD agreements or were the subject of separate action between Field Command/DNA and the ERDA Nevada Operations Office.

Project agencies were responsible for designing, preparing, and installing experiments, or delivering them to the installation contractor. After the event, these agencies were responsible for removing samples, analyzing instrument and sample data, and preparing project reports on experiment results.

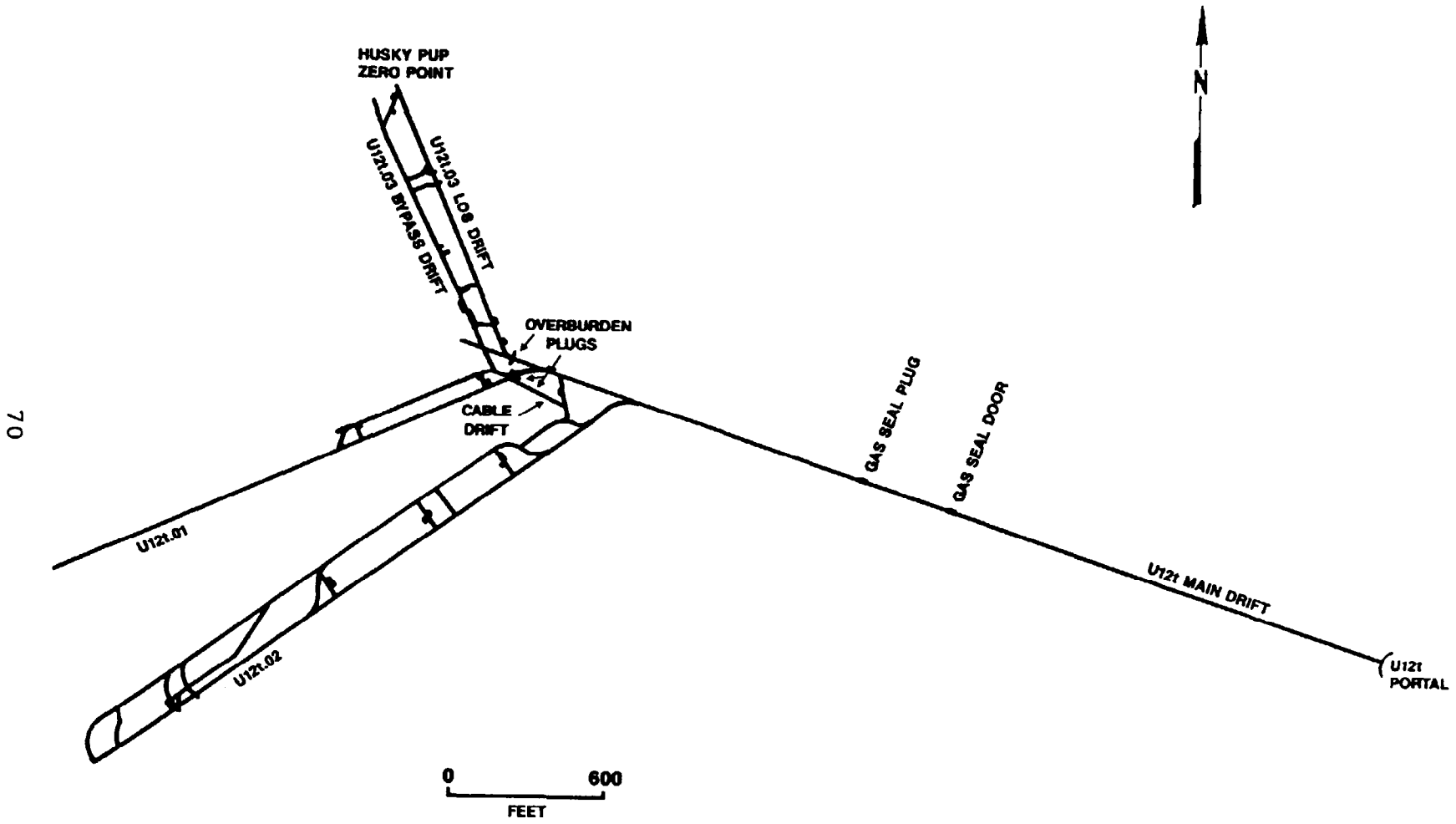

Figure 3.1 HUSKY PUP event - tunnel layout.

Device safety and security procedures in the zero point area and the timing and firing control room were in accordance with ERDA Manual Chapter 0560, "Program to Prevent Accidental or Unauthorized Nuclear Explosive Detonations." Because LASL fielded the device, the LASL Test Group Director was responsible for radiological safety within a 6,000-foot radius of the zero point from device emplacement until detonation. After detonation, the ERDA Test Controller relieved the LASL Test Group Director of responsibility. When the Test Controller determined that venting had not occurred, he delegated responsibility for radiological safety to the DOD Test Group Director.

3.2.2 Planning and Preparations.

A. Tunnel Facilities Construction.

The majority of the hardware concepts and technologies used in the vacuum pipe system design (LOS pipe) were refinements of those used on previous tests. The U12t.03 complex consisted of the LOS pipe drift, a bypass drift, four test chambers with associated cross-cuts, three overburden plugs (OBPs), and two alcove splice rack (ASR) plugs. Test chambers Nos. 1 and 2 and five sections of pipe were refurbished hardware from the HUSKY ACE event (an N tunnel event during 1973, discussed in DNA 6324F). The remainder of the pipe system components was newly fabricated. (Station Nos. 3 and 4 also were test chambers, see Figure 3.2). The main OBP was located at 3,540 feet into the T tunnel main drift, the mechanical OBP at 140 feet into the 01 drift, and the reusable cable OBP in the newly mined drift between the cable alcove and the 01 drift. Sampling, water, power, drain, and pressurization lines; a 36-inch manway; and a 24-inch vent tube were run through the mechanical OBP. Remote gas sampling capabilities were incorporated during construction, including lines to sample from the vent lines at the portal, zero point sides of the gas seal door and plug, portal and zero point sides of the OBP, and LOS drift

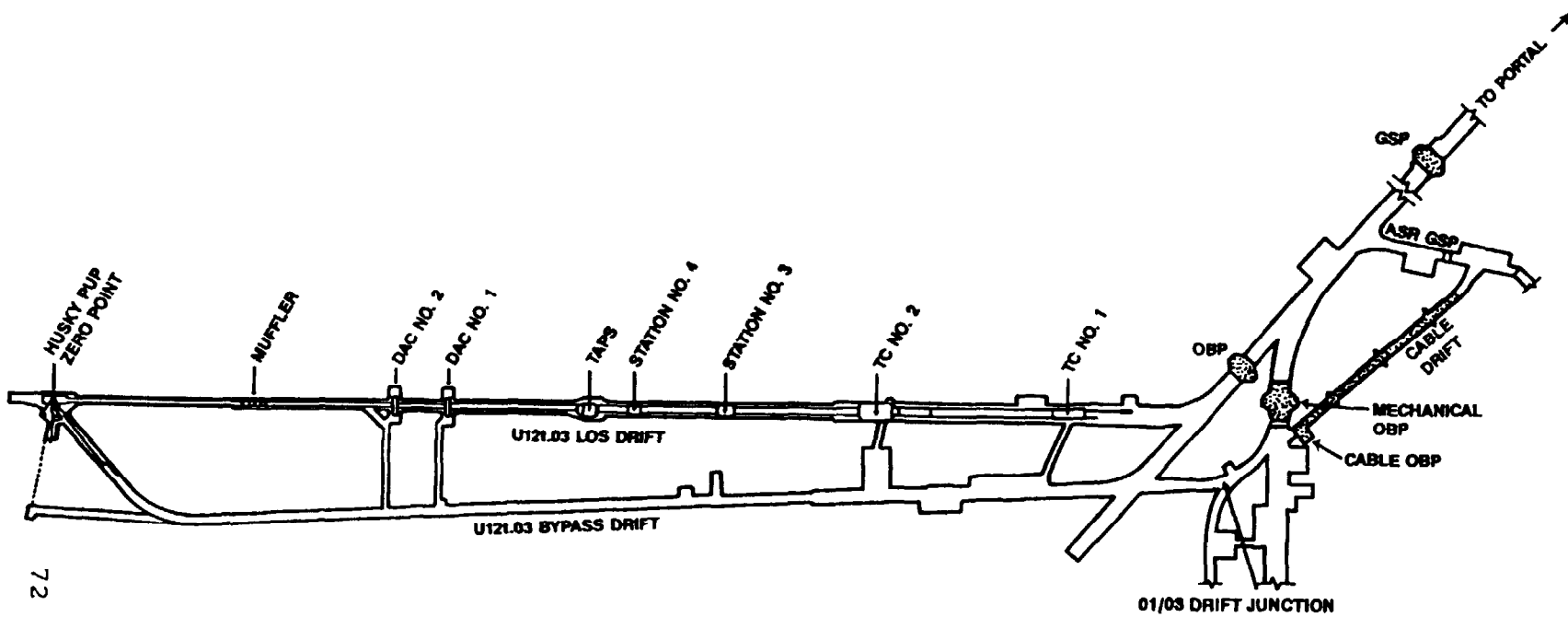

72

MAP NOT TO SCALE

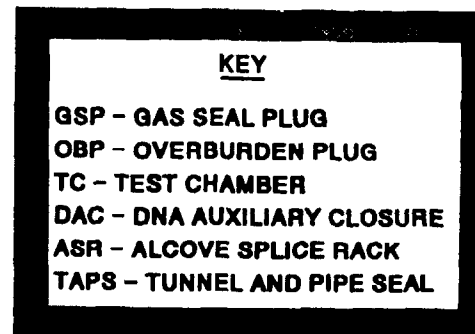

Figure 3.2 HUSKY PUP event - system configuration.

and pipe. Provisions to manually take gas samples from the zero point sides of the gas seal door, gas seal plug, and main OBP were made for sampling during postevent reentry.

Construction activities began in April 1974 with cleanup of the HUSKY ACE LOS pipe in preparation for its removal from the U12n.07 drift and use in the T tunnel HUSKY PUP event. Mining of the U12t.03 LOS drift was started in July 1974 and was completed when the zero point was reached in September 1974. Mining of the bypass drift and bypass alcoves began in October and was completed in December 1974. During January through March 1975, cable installation was begun and concrete pours for the DAC, TAPS, and the OBP inverters were completed. Installation of the LOS pipe began in April and was completed in June 1975. Experiments were installed between July and September 1975.

Dry run participation began in late August. Signal dry runs (SDRs) began 27 August. The first mandatory dry run (MDR) was held 9 September 1975. Generally, two mandatory signal dry runs (MSDs) were held each week thereafter. A successful mandatory full-power dry run (MFP) was conducted on 7 October 1975, the device was installed and pre-armed, and final stemming and button-up operations were begun.

B. Radiological Safety Support.

Procedures for radiation exposure and contamination control during this event were in accordance with ERDA Manual Chapter 0524 and requirements of responsible DOD representatives. Radsafe provided monitoring and equipment support.

Prior to the test, detailed radiological safety reentry plans were prepared and issued to participating agencies. Air sampling equipment was positioned in the

test area. Radsafe monitors were briefed regarding surface reentry, manned stations, and security station requirements.

Radsafe monitoring teams and supervisory personnel were provided to perform initial radiation surveys, conduct aerial surveys by helicopter, and participate in reentry parties as needed. Radsafe personnel also were standing by at Gate 300 prior to detonation to perform surveys and provide emergency support as directed; provide and issue anticontamination equipment and material, portable instruments, and dosimeters; operate area control check stations; and perform personnel, equipment, and vehicle decontamination, as required.

Available anticontamination materials and equipment included head covers, coveralls, cloth shoe covers, totes, full-face masks, supplied-air breathing apparatus, plastic suits, plastic bags, gloves, and masking tape.

C. Telemetry and Air Sampling Support.

In addition to permanent RAMS units, 33 temporary units provided surface and underground coverage for HUSKY PUP as shown in Table 3.1 and Figures 3.3 and 3.4. Also, an air sampling unit was placed at the tunnel portal. All RAMS units and the air sampling unit were installed a minimum of five days prior to scheduled device detonation.

EPA operated 46 air sampling stations and 30 gamma rate recorder stations in the offsite area. Twenty-five EPA personnel were fielded for offsite surveillance activities.

D. Security Coverage.

Device security procedures in the zero point area and the timing and firing control room were in accordance

Table 3.1. HUSKY PUP event RAMS unit locations
24 October 1975.

SURFACE

<u>Station</u>	<u>Location</u>
	<u>From the U12t portal:</u>
1	At the portal
2	208 feet S 81° W azimuth (on filter system)
3	222 feet S 75° W azimuth (on vent line)
4	222 feet S 75° W azimuth (on vent line)
5	332 feet N 09° W azimuth
6	345 feet N 68° E azimuth
7	346 feet S 55° E azimuth
8	388 feet S 07° E azimuth
9	324 feet S 43° W azimuth
10	564 feet N 74° W azimuth
11	650 feet S 82° E azimuth (at tunnel drain line)
12	2,020 feet S 89° E azimuth
	<u>From cable downhole:</u>
13	At cable downhole
14	264 feet N 04° W azimuth
15	219 feet N 62° E azimuth
16	150 feet S 17° E azimuth
17	165 feet S 87° W azimuth
	<u>From SGZ:</u>
18	311 feet N 01° W azimuth
19	490 feet S 60° E azimuth
20	503 feet S 61° W azimuth

Table 3.1. HUSKY PUP event RAMS unit locations
24 October 1975 (Continued).

UNDERGROUND

Station	Location
	<u>From the U12t main drift:</u>
21	345 feet into the U12t.03 LOS drift
22	155 feet into the U12t.03 LOS drift
23	250 feet into the U12t.03 bypass drift
24	50 feet into the U12t.03 bypass drift
*25ER	50 feet into the U12t.03 bypass drift
26	400 feet into the U12t.01 bypass drift
27	At the cable alcove
	<u>From the U12t portal:</u>
28	2,800 feet into the U12t main drift
29	2,240 feet into the U12t main drift
*30ER	2,240 feet into the U12t main drift
31	1,800 feet into the U12t main drift
32	900 feet into the U12t main drift
33	100 feet into the U12t main drift

* ER - Extended Range (instrument capable of reading 100 mR/h to 100,000 R/h)

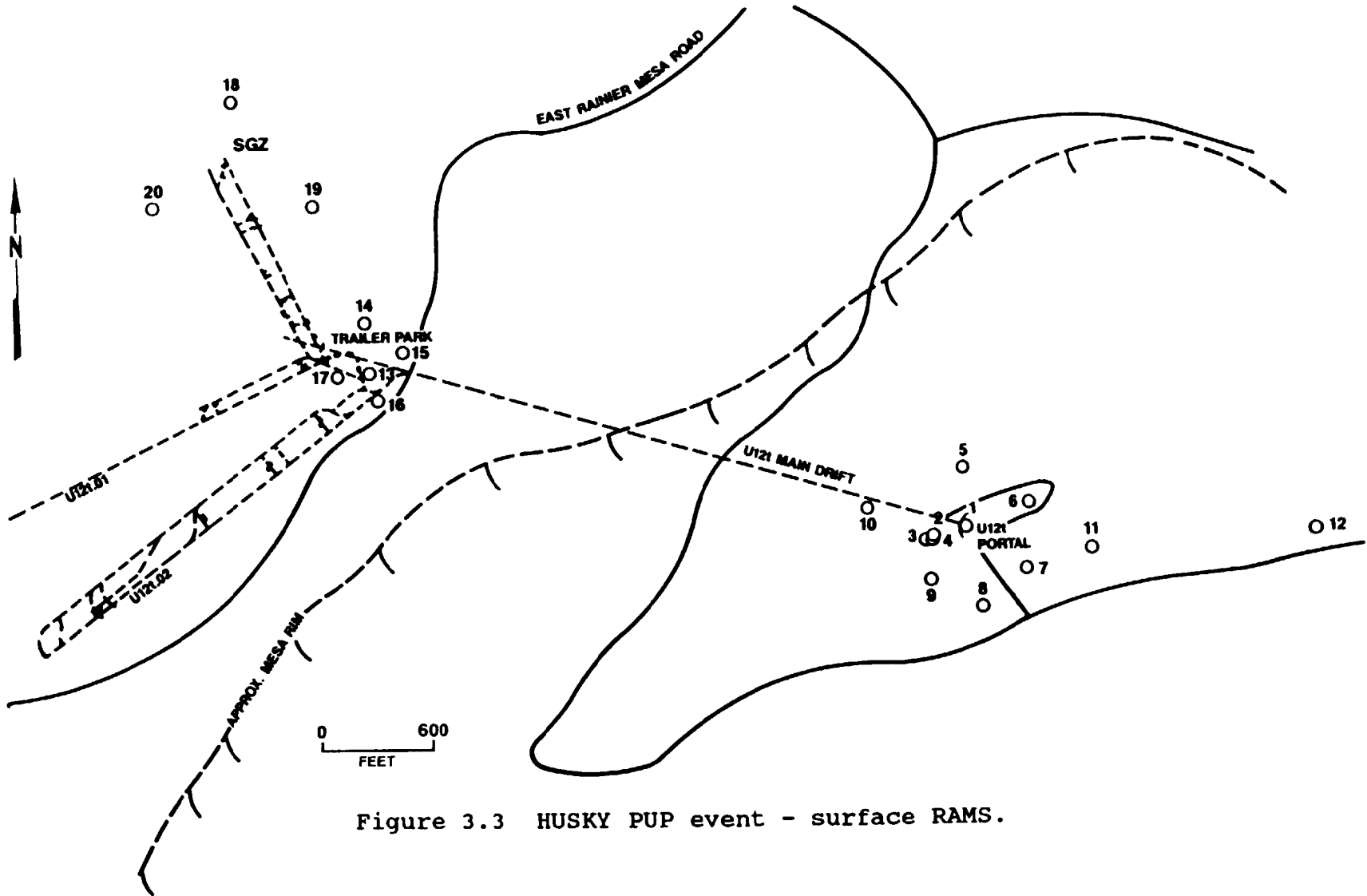

Figure 3.3 HUSKY PUP event - surface RAMS.

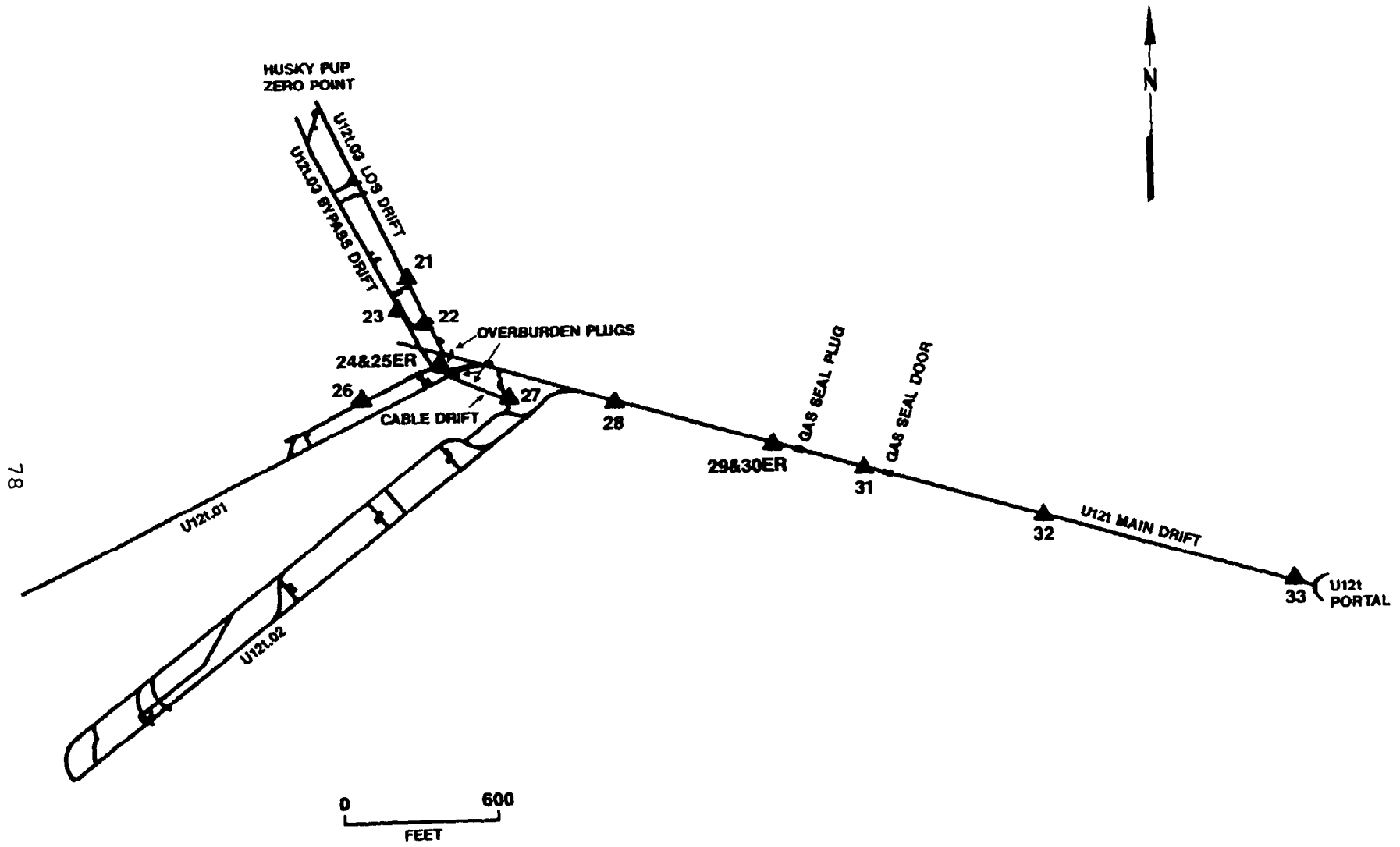

Figure 3.4 HUSKY PUP event - underground RAMS.

with ERDA Manual Chapter 0560, "Program to Prevent Accidental or Unauthorized Nuclear Explosive Detonations." Beginning on D-1, all personnel entering or exiting the controlled area were required to stop at muster or control stations for issue of stay-in badges, or issue and return of muster badges. After area control was established, all through traffic was diverted around the controlled area by use of screening stations.

In accordance with the "Test Controller's Operations and Security Plans," contractors and agencies were to have all personnel not connected with this event out of the closed area before the final security sweep began.

E. Air Support.

Three UH1N helicopters and crews were provided by the USAF for cloud tracking and the Test Controller's use, if needed. In addition, the USAF provided a C-130 and crew on standby status for cloud tracking. The EPA provided a Turbo Beech and crew for cloud sampling. Another EPA aircraft was standing by in Las Vegas to undertake tracking duties, if required.

3.3 EVENT-DAY ACTIVITIES.

3.3.1 Preshot Activities.

On 24 October 1975 at 0001 hours, all persons except the arming party, tunnel button-up party, microwave timing party, and security guards were out of the tunnel and clear of the muster area. At 0430 hours, permission was granted to arm the device. By 0700 hours, button-up was completed.

A readiness briefing was held at 0800 hours on 24 October 1975 in anticipation of planned test execution at 1000 hours that day. Conditions for test execution were favorable, and all personnel were mustered out of the area by 0900 hours. The countdown started as planned at 0945 hours but was held for 11

minutes in an attempt to verify the operation of a redundant OBP valve. The valve would not operate properly, but because it was locked in the closed position, the decision was made to go ahead with the test.

The HUSKY PUP device was detonated at 1011 hours PDT on 24 October 1975. Subsurface cavity collapse occurred at 1515 hours.

3.3.2 Test Area Monitoring.

Telemetry measurements began at 1013 hours on 24 October 1975. RAMS unit No. 26 located in the U12t.01 bypass immediately was off line (not working). The RAMS units located in the LOS drift responded to neutron activation of the LOS pipe and experiments. These units, RAMS Nos. 21 and 22, were reading 650 R/h and 350 R/h, respectively, immediately after detonation. Normal decay of this activation radiation was observed. No indications of radioactive effluent were detected by any tunnel, surface, or airborne radiation monitoring units. All RAMS units were secured at 1012 hours on 28 October, when RAMS unit Nos. 21 and 22 were reading 18 mR/h and 9 mR/h, respectively.

3.3.3 Initial Surface Radiation Surveys and Recovery Activities.

Four reentry teams (two teams to survey the Mesa trailer park, one team to survey the portal area, and one team to survey the portal area ventilation system, see Figure 3.5) were released from Gate 300 at 1057 hours on the day of detonation. The portal area surveys were completed at 1130 hours, and the Mesa survey was completed at 1146 hours. No radiation levels above background (0.05 mR/h) were detected. Mesa and portal data recovery was conducted between 1225 and 1510 hours. Data recovery teams included SLA, Air Force Weapons Laboratory (AFWL), Lockheed Missile and Space Corporation/Navy Strategic Systems Project Office (LMSC/SSPO), Kaman Science Corporation (KSC), Science Applications, Inc. (SAI), Lockheed Palo Alto Research Laboratory (LPARL), Physics International (PI), and LASL personnel. Gas samples were obtained remotely from the zero point side of the OBP at 1515 hours. No toxic gas or positive



Figure 3.5 Aerial view of the U12t portal and mesa areas.

LEL level was noted in the LOS drift, and tunnel ventilation was reactivated. D-day reentry survey operations were terminated at 1600 hours.

3.4 POSTEVENT ACTIVITIES.

3.4.1 Tunnel Reentry Activities.

At 0810 hours on 25 October (D+1), a work party, accompanied by monitoring and industrial hygiene personnel, entered the tunnel en route to the gas seal door. Personnel were not required to wear anticontamination clothing or respiratory protection equipment. They arrived at the gas seal door at 0816 hours. No positive toxic gas, LEL, or radiation levels were detected on either side of the door. Water was noted on the zero point side of the door, so the drain line was opened and the in-line sump pump was put in operation. The gas seal door was opened at 0930 hours, and railroad tracks were reinstalled through the gas seal door.

The work party then moved to the gas seal plug. Air through the 36-inch crawl space in the gas seal plug showed no indication of toxic gas or positive LEL levels, and radiation readings at background. The vent line was hooked up through the plug at 1015 hours. A member of the work party crawled through the gas seal plug to see if there was any standing water on the zero point side, but no water was found. At 1055 hours, the rescue team and reentry team Nos. 1 and 2 left the portal and traveled by train to the gas seal plug. Team No. 1 was to serve as the primary reentry team, and team No. 2 was to stand by on the portal side of the OBP to replace team No. 1 if necessary on the reentry. The work party returned to the portal.

Permission was granted for reentry through the gas seal plug and towards the mechanical OBP. At 1110 hours, team No. 1, in full anticontamination clothing and self-contained breathing apparatus (SCBA), had moved through the plug; no toxic gas or above-zero LEL levels were noted, and the radiation level was at

background. As team No. 1 moved towards the OBP, minimal damage to the tunnel was observed.

The mechanical OBP was reached at 1126 hours. Air samples taken from the zero point side of this OBP showed no indication of toxic gas, positive LEL, or above-background radiation levels. A water pump was started to draw out whatever water might exist on the zero point side of the plug. At 1156 hours, the rescue team and team No. 2 moved up to the mechanical OBP. The doors on each end of the OBP manway were opened and the ventilation lines were reconnected. At 1205 hours, team No. 1 had moved through the OBP and started towards the 03 drift.

The first above-background radiation reading encountered was 5 mR/h at the main drift/03 LOS drift junction. The LOS stubs area was reached at 1210 hours, and a reading of 80 mR/h was observed. In the LOS drift, industrial hygiene checks for toxic gas and LEL levels showed no positive results. Team No. 1 moved through the 03 bypass drift to the test chamber No. 1 crosscut, and sandbags in the crosscut were removed to provide access to the test chamber area. The maximum reading taken at contact with the outside of the test chamber was 200 mR/h. A reading of 400 mR/h was taken on a section of the LOS pipe near the test chamber. Toxic gas checks inside the vent pipe above the test chamber indicated 1,300 ppm of carbon monoxide, a 19 percent oxygen level, and 5 percent of the LEL. At 1228 hours, the door to test chamber No. 1 was opened. A radiation reading of 400 mR/h, a toxic gas level of 750 ppm of carbon monoxide, 5 percent of the LEL, and a 19 percent oxygen level were measured at arm's length inside the test chamber. No debris was observed in the bottom of the chamber, and air flow into the chamber was noted.

Leaving the door to test chamber No. 1 open, team No. 1 moved towards crosscut No. 2, observing damage in several of the alcoves. At 1320 hours, the exposure rate outside the sandbag plug was background, and the maximum reading at contact with the sandbags was 5 mR/h. Again, sandbags were moved to facilitate entry into the test chamber area. The exposure rate in the work

area at the beginning of sandbag removal was 0.1 mR/h. As the team moved closer to the test chamber through the sandbags, the exposure rate increased to 10 mR/h. A passageway was formed through the sandbags and the team approached test chamber No. 2. At 1340 hours, a reading of 140 mR/h was taken at contact with the LOS pipe on the portal side of test chamber No. 2. At 1345 hours, the test chamber door was partially opened, and 10 percent of the LEL and 1,300 ppm of carbon monoxide were measured just inside the door. The radiation reading at arm's length inside the test chamber was 140 mR/h.

At 1400 hours, film recovery from one of the alcoves was begun. At 1409 hours, recovery of the film had been completed and team No. 1 prepared to exit the tunnel. The team stopped to fasten closed the door to test chamber No. 1 as an aid in ventilation of the LOS pipe. At 1411 hours, permission for team members to remove their face masks was received. The team re-connected the vent line on the zero point side of the mechanical OBP before returning through the plug. Clothing of team members was surveyed by Radsafe personnel from team No. 2 upon return through the OBP. No contamination was detected. Swipes taken from inside the test chambers read background when checked with a portable Geiger-Mueller detector, indicating no radioactive debris had entered the test chambers as a result of device detonation. At 1434 hours, the train had returned with all the teams to the portal. This concluded initial reentry operations.

A tunnel hazard and damage survey was begun at 0910 hours on 28 October 1975 and completed at 1015 hours before recovery personnel were allowed into the tunnel work areas. The exposure rate at each test chamber had decreased to 10 mR/h, and the exposure rate in the stubs area was 3 mR/h. A work party began to install railroad tracks and repair damage to the ventilation system in the 03 bypass drift. At 1100 hours, an assessment party in full anticontamination clothing and full-face masks with high efficiency particulate aerosol (HEPA) filters went to view experiments in the LOS pipe. Two members of the party donned SCBA and entered the LOS pipe to view the TAPS. At 1500 hours, experimenters were allowed into test chamber No. 2 for removal of

hazardous and time-degradable experiments. The exposure rate in the chamber was 7 mR/h. All personnel in the LOS pipe were required to wear full anti-contamination clothing (including coveralls, hoods, totes, and gloves) and full-face masks with HEPA filters. These requirements remained in effect throughout the recovery period for all personnel working in the test chambers. Any exceptions to these requirements were made only with the permission of the SLA Health Physicist. At 1600 hours, miners began work on mining out the gas seal plug and mechanical OBP. Experiment recovery personnel exited the LOS and test chamber areas by 1730 hours. The gas seal plug was completely mined out and railroad tracks were relaid during the night. Work to open up the mechanical OBP continued.

On 30 October, experiment recovery personnel entered test chambers No. 1 and 2 to continue experiment removal. The exposure rate inside the LOS pipe work area was 4 mR/h, and no carbon monoxide and 0 percent of the LEL were observed. All personnel were out of the 03 bypass drift and LOS pipe area by 1700 hours. Miners continued to work on the OBP.

Railroad tracks were installed through the OBP on the morning of 31 October 1975. At 0900 hours, recovery personnel returned and continued experiment removal. All personnel were out of the recovery area by 1245 hours; contamination was not detected on their personal clothing.

Ventilation was established at 1515 hours on the zero point side of the TAPS door by SLA and Radsafe personnel wearing full anticontamination clothing and SCBA. A survey of the air from the zero point side of the TAPS showed less than the LEL and a 1 mR/h exposure rate. The air in the main vent line at the 01 drift/03 drift junction (through which the air behind the TAPS was being drawn) showed zero percent of the LEL and only a trace of carbon monoxide when surveyed.

On 3, 4, 5, and 7 November 1975, experimenter personnel continued recoveries in the LOS drift and test chambers Nos. 1

and 2. Mining personnel worked to rehabilitate the 03 bypass drift and damaged crosscuts. On 3 November, the flex line above test chamber No. 2 (drawing air from behind the TAPS) showed 100 ppm of carbon monoxide and 15 percent of the LEL. The flex line at the TAPS door also was tested and showed 100 percent of the LEL with 5,500 ppm of carbon monoxide. Because there was no pressure behind the TAPS door, ventilation was discontinued. Full-face masks continued to be a requirement for personnel in both test chambers. Recoveries from test chamber No. 1 were completed on 4 November.

After experimenter personnel had left the area on 4 November, ventilation was reestablished behind the TAPS door. At the time of hookup of the flex line, 100 percent of the LEL and 2,000 ppm of carbon monoxide were measured. Compressed air was forced onto the zero point side of the TAPS door to supply positive air pressure for ventilation. By day shift on 5 November, zero percent of the LEL and only a trace of carbon monoxide were indicated in the 03 bypass vent line. By 1100 hours on 7 November, all experiments had been removed.

The miners continued to clean up and rehabilitate the LOS and bypass drifts on 10 November. Also, pipefitters began work in the LOS pipe to open the TAPS door this date. By 12 November, the TAPS door had been loosened. Levels of 10 ppm of carbon monoxide and 10 percent of the LEL were measured behind the TAPS. Water began to flow from behind the TAPS and the pipefitters were required to leave the area. No beta or gamma activity was detected in this water. A pump was placed and a hole was drilled in the bottom of the LOS pipe to drain the water. A gas sample drawn from the zero point side of the TAPS on 13 November showed no indication of toxic gases and zero percent of the LEL. Pipefitters opened the door at 1000 hours that day. An assessment survey was performed from the TAPS toward DAC No. 1. The LOS pipe was extensively damaged; readings of 0.08 mrad/h (beta plus gamma) and 10 percent of the LEL were made at the furthest accessible point (100 feet from the TAPS). No toxic gases were detected.

At 1030 hours on 14 November 1975, DNA and Pan Am photographers entered the TAPS area. At 1300 hours the same day, an H&N party entered the LOS pipe for an engineering survey. All personnel were out of the LOS area by 1500 hours. This completed reentry and recovery activities. Miners continued cleanup and rehabilitation in the LOS area through 19 November, when work in the area was abandoned.

3.4.2 Postevent Mining.

Work resumed in the 03 bypass drift on 12 July 1976 to assess the performance of the DAC and to recover items from DAC No. 2. An air quality and radiation survey was conducted that morning prior to allowing workers in the area. The radiation level was at background, and 6,400 ppm of carbon dioxide was noted; no indications of carbon monoxide were found. Water was observed on the invert. The vent line was hooked up to about 325 feet into the drift to restore ventilation. By 1415 hours, the carbon dioxide level had dropped to 2,400 ppm at 350 feet into the drift. Miners started cleanup operations the next day. A test of the air showed the carbon dioxide level to be at 3,200 ppm. Mucking operations were started on the portal side of the vent line end. Water samples were collected at 350 feet into the 03 bypass drift and from the LOS pipe at crosscut No. 1. No above-background radiation readings were noted from these samples. A survey showed that the carbon dioxide level varied from 900 ppm to 1,300 ppm from the Radsafe station to 350 feet into the bypass drift, so the vent line was extended to about 400 feet into the drift.

As mucking and mining activities proceeded, the vent line was moved back to 325 feet into the drift because it interfered with operations. The carbon dioxide level was at 2,600 ppm on 15 July when blasting and mucking operations on the 03 reentry drift began. During this mining, an 18- to 22-foot probe hole was drilled in the face before each round was loaded to determine if radiation would be encountered or if any other hazard might exist after the round was fired. No radiation was encountered during any probe. The carbon dioxide level did not, however, return to

that of normal air. Mining operations continued through 30 July, when the heading was at 135 feet into the 03 reentry drift and the miners were sent to work in N tunnel. No further reentry mining was conducted for the HUSKY PUP event.

3.4.3 Postevent Drilling.

No drilling to recover zero point core samples was performed for the HUSKY PUP event from the Mesa or any underground area.

3.4.4 Industrial Safety.

Checks for the presence of toxic gases and surveys to measure radiation and LEL levels were made on each shift. The results were then recorded in the monitors' logbook.

Appropriate safety measures were taken to protect mining personnel and prevent unsafe conditions. Industrial safety codes, including specific codes for mining, tunneling, and drilling, were established by REECO and emphasized during all operations. A written standard operating procedure was required for each operation involving explosives, toxic materials, radioactive material, or any other operation with the potential for personal injury. Each individual involved in such an operation was required to know the contents of the applicable procedures.

The portal construction area and the tunnel were mandatory hard hat and foot protection areas (safety shoes, safety boots, ERDA-issued miner's boots, or toe guards). All personnel on the initial tunnel reentry teams were certified in the use of the Draeger self-contained breathing apparatus and had used the McCaa two-hour breathing apparatus. Standard safety rules and regulations, as spelled out in the "U.S. Bureau of Mines Manual," were observed.

All explosives, electro-explosive components, solid propellants, toxic materials, and radioactive materials were handled,

stored, and transported in accordance with applicable sections of the following documents:

1. Army Materiel Command Regulations (AMCR 385-224).
2. AEC Manual 0500 Series for the Nevada Test Site.*
3. Individual Safe Operating Procedures (by experimenter organization).
4. HUSKY PUP Safety Regulations.

All personnel engaged in handling, storing, assembling, or installing explosives, propellants, or electro-explosive devices (or observers of those operations) were required to wear safety glasses or other eye protection which had been approved by the DOD Safety Coordinator.

3.5 RESULTS AND CONCLUSIONS.

Telemetry measurements began at 1013 hours on 24 October and all telemetry stations were secured at 1012 hours on 28 October. No radiation other than that from normal activation products was detected by telemetry units.

The initial radiation surveys began at 1057 hours on 24 October and were completed at 1146 hours. No radiation above background was detected at the Mesa trailer park area or at the tunnel complex portal.

Reentry into the tunnel began at 0810 hours on 25 October. A maximum reading of 400 mR/h was detected at contact with the LOS pipe near test chamber No. 1 and at arm's length inside test chamber No. 1. The maximum toxic gas concentration and LEL percentage detected during initial reentry were 1,300 ppm of carbon monoxide and 10 percent of the LEL, respectively, measured inside the door to test chamber No. 2.

*Applicable parts of the AEC NTSO SOP 0500 series were not superceded until 1982.

During experiment recovery, no airborne radioactive contamination was detected. Readings of 5,500 ppm of carbon monoxide and 100 percent of the LEL were observed in a flex line during ventilation of the zero point side of the TAPS; therefore, respiratory protection equipment was required inside the LOS pipe throughout experiment recoveries. All experiments were recovered between 28 October and 7 November 1975.

On 12 July 1976, reentry mining operations began in the 03 bypass drift. This effort continued until 30 July 1976 when miners were moved to N tunnel for another mining operation. No radiation was encountered during the mining of the reentry drift, but positive carbon dioxide readings were noted throughout the work period. No further reentry activities were pursued.

No drilling for recovery of core samples was conducted from the Mesa or from any underground location for the HUSKY PUP event.

Personnel exposure data from self-reading pocket dosimeters were documented on Area Access Registers during individual entries to HUSKY PUP radex areas from 25 October to 11 November 1975, when the use of Area Access Registers was discontinued. A total of 133 entries into Radex areas was recorded, 44 of which were made by DOD-affiliated participants. Although pocket dosimeters showed some indication of possible radiation exposure, film badges worn by reentry personnel (those most likely to be exposed) indicated no evidence of any gamma exposures. The minimum detectable gamma exposure with the NTS film dosimeter was 30 mR.

SECTION 4

MIGHTY EPIC EVENT

4.1 EVENT SUMMARY.

MIGHTY EPIC was a DOD-sponsored test conducted at 1250 hours Pacific Daylight Time (PDT) on 12 May 1976 with a yield of less than 20 kilotons. The test was the seventh in the Hussar Sword series. The device was detonated in the U12n.10 drift of the N tunnel complex (Figure 4.1) at a vertical depth of 1,306 feet. The purpose of the event was to test the response of materials and equipment to a nuclear detonation environment, study effects of severe ground shock on hardened structures, and observe the geologic interface with each type of structure. An evacuated horizontal LOS pipe 1,800 feet long was used to house experiments. DOD and supporting organizations conducted 27 projects to obtain the desired information.

Stemming was successful and containment was complete. No radioactive effluent from the test was detected onsite or offsite.

4.2 PREEVENT ACTIVITIES.

4.2.1 Responsibilities.

Safe conduct of all MIGHTY EPIC project activities in Area 12 was the responsibility of the DOD Test Group Director. Responsibilities of ERDA and ERDA contractor personnel were in accordance with established ERDA-DOD agreements or were the subject of separate action between Field Command/DNA, and the ERDA Nevada Operations Office.

Project agencies were responsible for designing, preparing, and installing experiments or delivering them to the installation contractor. After the event, these agencies were responsible for

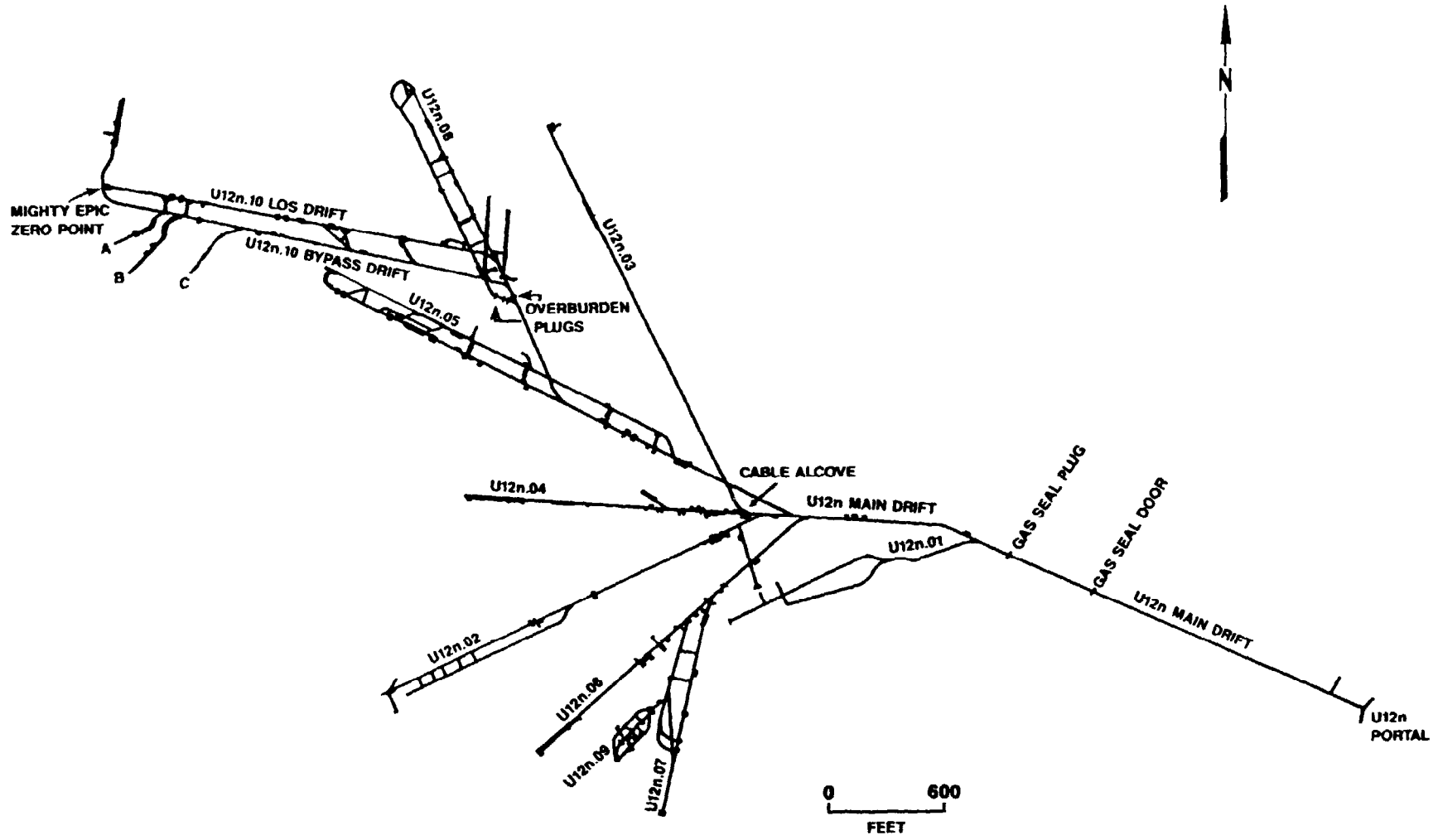

Figure 4.1 MIGHTY EPIC event - tunnel layout.

removing samples, analyzing instrument and sample data, and preparing project reports on experiment results.

Device safety and security procedures in the zero point area and the timing and firing control room were in accordance with ERDA Manual Chapter 0560, "Program to Prevent Accidental or Unauthorized Nuclear Explosive Detonations." Because LLL fielded the device, the LLL Test Group Director was responsible for radiological safety within a 6,000-foot radius of the zero point from device emplacement until detonation. After detonation, the ERDA Test Controller relieved the LLL Test Group Director of responsibility. When the Test Controller determined that venting had not occurred, he delegated responsibility for radiological safety to the DOD Test Group Director.

4.2.2 Planning and Preparations.

A. Tunnel Facilities Construction.

Lockheed Missiles & Space Co., Inc. (LMSC) was responsible by contract for providing the design of the basic test facilities, developing the delivery schedule, and monitoring the installation of hardware and operation of the vacuum system for the MIGHTY EPIC LOS facilities.

The MIGHTY EPIC program was conducted as part of a concept for cost-effectiveness called the "two-for-one" plan. This plan consisted of executing two underground tests in succession, using as much of the same hardware, tunnel area, and installations as possible from the first test for the second test. After execution of the first event (MIGHTY EPIC), a new zero point would be located some 500 feet closer to the portal for the second test (DIABLO HAWK, see Chapter 6).

The LOS pipe system was composed of an 1,800-foot LOS pipe containing four test chambers (one being a high-fluence station) to house experiments, a diagnostic stub

system, and two discrete scatterer systems. Ten data and two background detectors were fielded to measure the total x-ray fluence. To supplement the x-ray experiments, the A, B, and C structure drifts and the interface drift were excavated for ground shock and interface movement experiments. (See Figure 4.2.) Two main crosscuts connected the test chambers to the 10 bypass drift, and two smaller crosscuts provided access to the LOS drift from the A and B structure drifts. ROSES units, used to monitor and record test results underground, were located in drift U12n.11, mined off the U12n.08 drift; and detection and recording trailers were placed on the Mesa and at the tunnel portal to remotely measure test results. A cable drift connecting underground monitoring equipment with surface recorders was drilled into the interface drift. Experimenters represented in the test included FC/DNA; Space and Missile Systems Organization (SAMSO); Navy Strategic Systems Project Office (SSPO); AFWL; Kaman Sciences Corporation/Lockheed Missile and Space Corporation (KSC/LMSC); LPARL; Science Applications, Incorporated (SAI); Merritt Cases, Inc. (CASES); Stanford Research Institute (SRI); Agabian Association (AA); Waterways Experiment Station (WES); Systems, Science and Software (SSS); PI; LMSC; KSC; Field Command, Test Management, Test Director (FCTMD); Field Command, Test Management, Construction (FCTMC); Technical Representatives, Incorporated (TRI); DNA/EDAC (Engineering Decision Analysis Company); General Electric (GE); LMSC/SSPO; C. S. Draper Laboratory (Draper); SLA, LASL, and LLL.

B. Radiological Safety Support.

Procedures for radiation exposure and contamination control during this event were in accordance with ERDA Manual Chapter 0524 and requirements of responsible DOD representatives. Radsafe provided monitoring and equipment support.

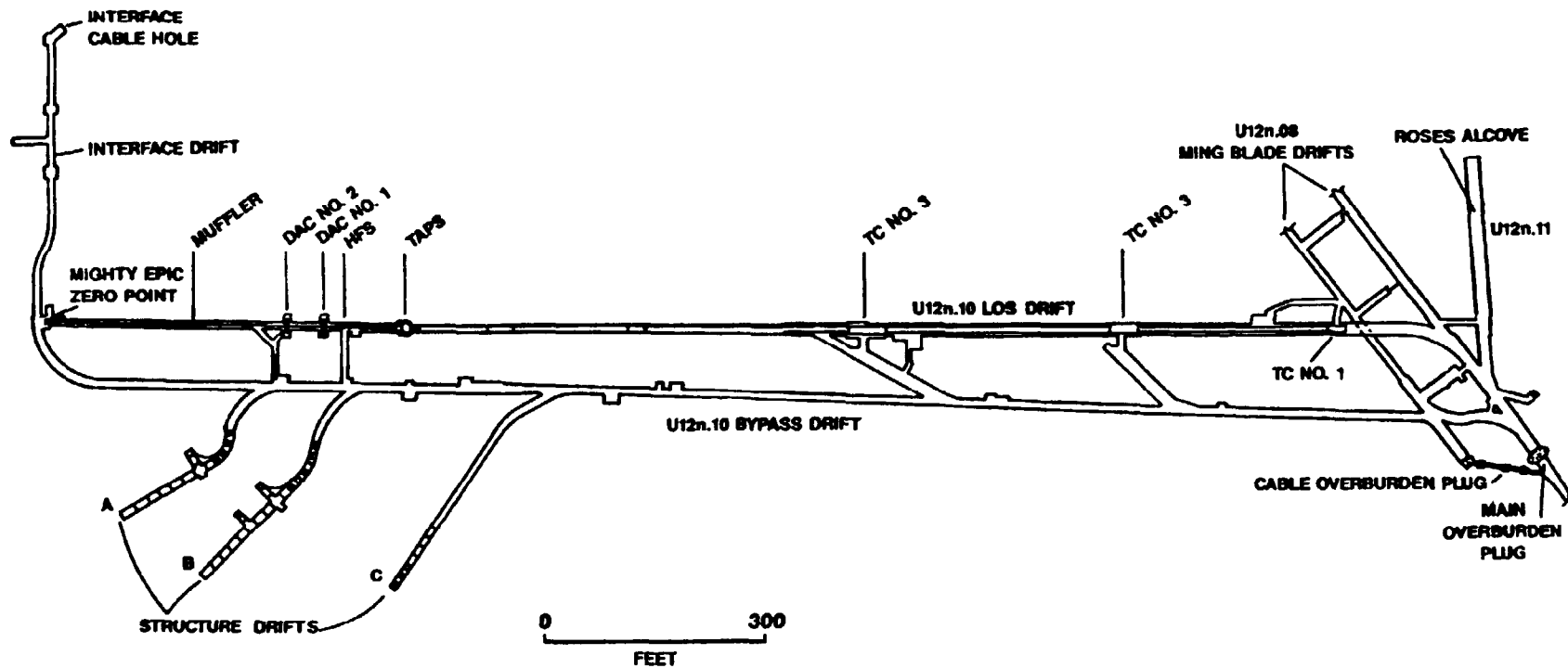

KEY

DAC - DNA AUXILIARY CLOSURE
 TC - TEST CHAMBER
 HFS - HIGH FLUENCE SCATTERER
 TAPS - TUNNEL AND PIPE SEAL

Figure 4.2 MIGHTY EPIC event - tunnel and pipe layout.

Prior to the test, detailed radiological safety reentry plans were prepared and issued to participating agencies. Air sampling equipment was positioned in the test area. Radsafe monitors were briefed regarding surface reentry, manned stations, and security station requirements.

Radsafe monitoring teams and supervisory personnel were provided to perform initial radiation surveys, conduct aerial surveys by helicopter, and participate in reentry parties as needed. Radsafe personnel also were standing by at Gate 300 prior to detonation to perform surveys and provide emergency support as directed; provide and issue anticontamination equipment and material, portable instruments, and dosimeters; operate area control check stations; and perform personnel, equipment, and vehicle decontamination, as required.

Available anticontamination materials and equipment included head covers, coveralls, cloth shoe covers, totes, full-face masks, supplied-air breathing apparatus, plastic suits, plastic bags, gloves, and masking tape.

C. Telemetry and Air Sampling Support.

In addition to permanent RAMS units, 40 temporary units provided surface and underground coverage for MIGHTY EPIC as shown in Table 4.1 and Figures 4.3 and 4.4. Also, an air sampling unit was placed at the tunnel portal. All RAMS units and the air sampling unit were installed a minimum of five days prior to scheduled device detonation.

EPA operated 16 air sampling stations and 32 gamma rate recorder stations in the offsite area. Two hundred seventy thermoluminescent dosimeters (TLDs) also were placed to verify offsite radiation levels. Twenty-one

Table 4.1. MIGHTY EPIC event RAMS unit locations
12 May 1976.

SURFACE

<u>Station</u>	<u>Location</u>
	<u>From the U12n portal:</u>
1	At the portal
2	On the filter system
3	On the vent line
4	On the vent line
5	On the tunnel drain line
6	399 feet N 16° E azimuth
7	275 feet N 89° E azimuth
8	364 feet S 16° E azimuth
9	482 feet S 12° W azimuth
10	558 feet S 48° W azimuth
11	417 feet N 69° W azimuth
12	1,369 feet S 43° E azimuth
	<u>From the cable downhole:</u>
13	At cable downhole
14	177 feet N 43° E azimuth
15	135 feet S 33° E azimuth
16	375 feet S 31° W azimuth
17	78 feet S 89° W azimuth
	<u>From the U12n.10 SGZ:</u>
18	455 feet N 22° E azimuth
19	688 feet S 61° E azimuth
20	426 feet S 39° W azimuth
ICH	At the interface cable hole
VH	At the mesa vent hole

Table 4.1. MIGHTY EPIC event RAMS unit locations
12 May 1976 (Continued).

UNDERGROUND

<u>Station</u>	<u>Location</u>
	<u>From the U12n.08 drift unless otherwise indicated:</u>
21	880 feet into the U12n.10 LOS drift
22	510 feet into the U12n.10 LOS drift
23	110 feet into the U12n.10 LOS drift
24	500 feet into the U12n.10 bypass drift
25	200 feet into the U12n.10 bypass drift
26	85 feet into the U12n.10 bypass drift
*27ER	85 feet into the U12n.10 bypass drift
28	150 feet into the U12n.11 drift
29	435 feet into the U12n.08 drift from the U12n.05 drift
	<u>From the U12n main drift:</u>
30	1,900 feet into the U12n.05 bypass drift
31	600 feet into the U12n.05 drift
	<u>From the U12n portal unless otherwise indicated:</u>
32	2,600 feet into the U12n main drift
33	2,050 feet into the U12n main drift
*34ER	2,050 feet into the U12n main drift
35	1,700 feet into the U12n main drift
36	1,200 feet into the U12n main drift
37	50 feet into the U12n vent line raise from the U12n main drift
38	200 feet into the U12n main drift

* ER - Extended Range (instrument capable of reading 100 mR/h to
100,000 R/h)

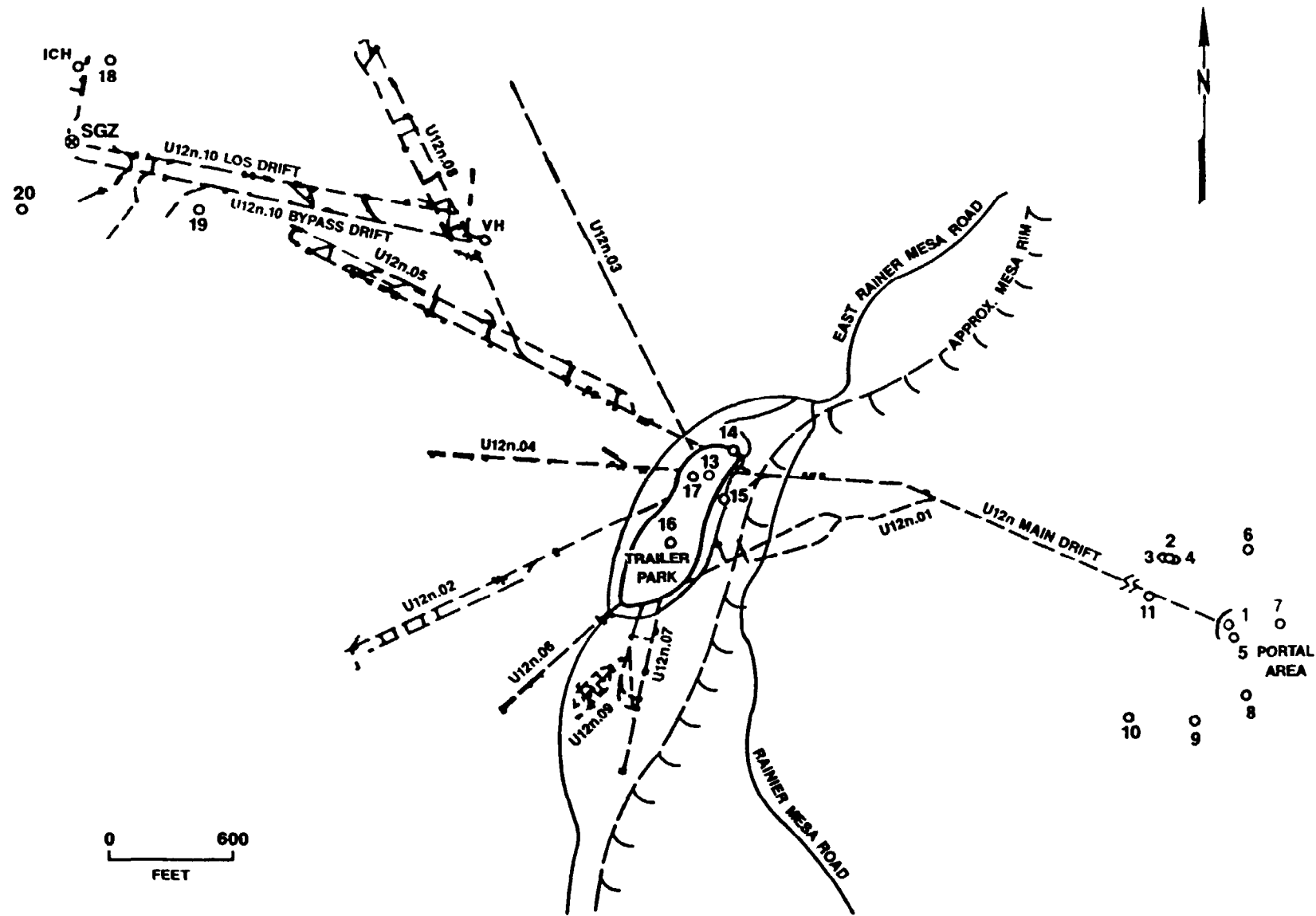

Figure 4.3 MIGHTY EPIC event - surface RAMS.

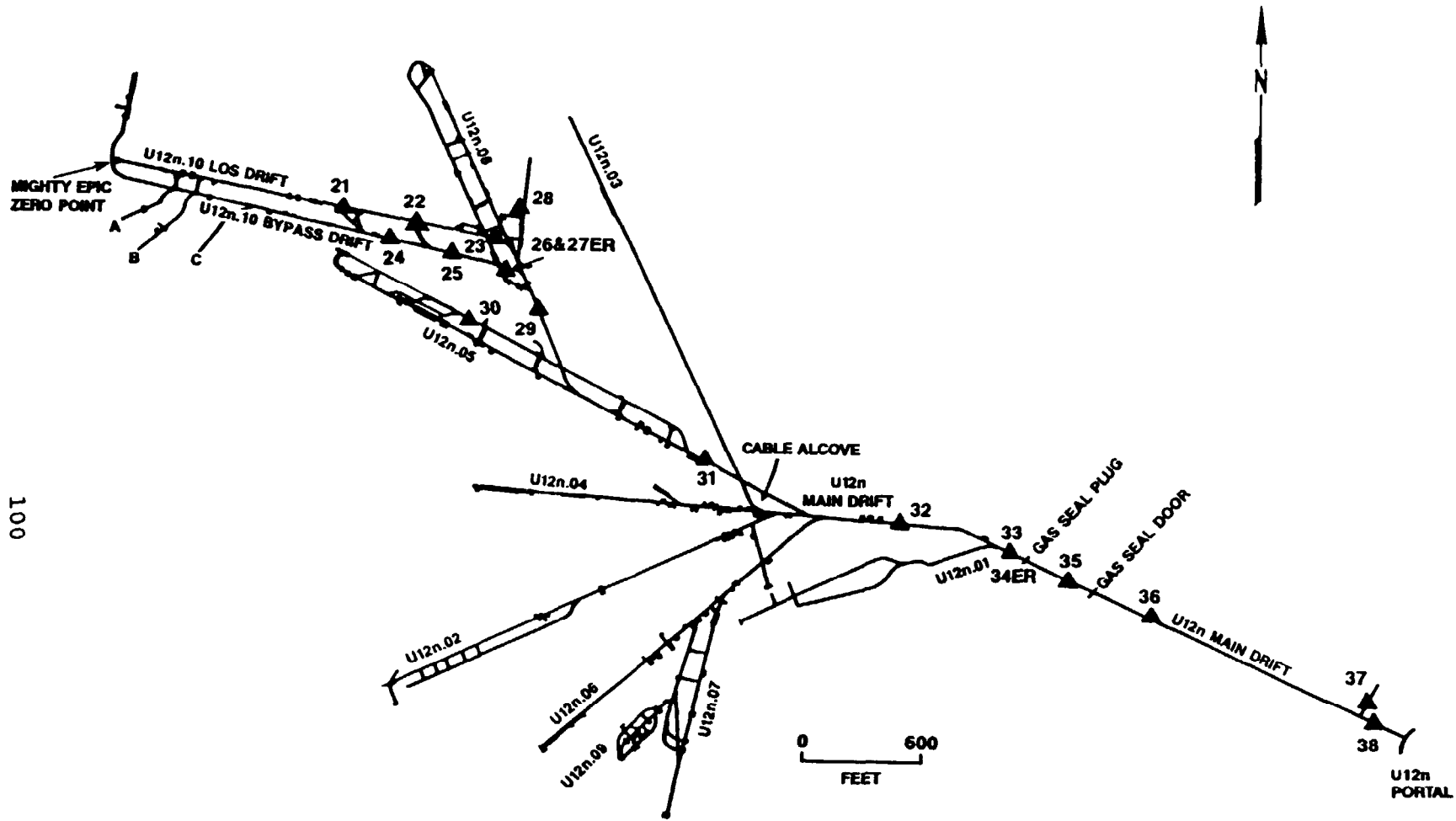

Figure 4.4 MIGHTY EPIC event - underground RAMS.

EPA personnel were fielded for offsite surveillance activities.

D. Security Coverage.

Device security procedures in the zero point area and the timing and firing control room were in accordance with ERDA Manual Chapter 0560, "Program to Prevent Accidental or Unauthorized Nuclear Explosive Detonations." Beginning on D-1, all personnel entering or exiting the controlled area were required to stop at muster or control stations for issue of stay-in badges, or issue and return of muster badges. After area control was established, all through traffic was diverted around the controlled area by use of screening stations.

In accordance with the "Test Controller's Operations and Security Plans," contractors and agencies were to have all personnel not connected with this event out of the closed area before the final security sweep began.

E. Air Support.

Three UH1N helicopters and crews were provided by the USAF for cloud tracking and the Test Controller's use, if needed. In addition, the USAF provided a C-130 and crew on standby status for cloud tracking. The EPA provided a Turbo Beech and crew for cloud sampling. Another EPA aircraft was standing by in Las Vegas to undertake tracking duties, if required.

4.3 EVENT-DAY ACTIVITIES.

4.3.1 Preshot Activities.

On 12 May at 0001 hours, all persons except the arming party, tunnel button-up party, microwave timing party, and security guards were out of the tunnel and clear of the muster

area. Permission was granted to arm the device. Button-up was delayed because problems with experiments existed.

A readiness briefing was held at 0600 hours on 12 May in anticipation of planned test execution between 0900 and 1100 hours that day. The time was not fixed because the above-mentioned problems with the experiments were not resolved. Conditions for test execution became favorable, and by 1025 hours, all personnel were mustered out of the area.

The MIGHTY EPIC device was detonated at 1250 hours PDT on 12 May 1976.

4.3.2 Test Area Monitoring.

Telemetry measurements began at 1251 hours on 12 May 1976. RAMS unit Nos. 2 through 12, 15, 35, and 37 (located as shown in Figures 4.3 and 4.4) were driven negative by electromagnetic pulse (EMP) but later recovered. RAMS unit No. 21 was made inoperable by the detonation and never recovered. The RAMS units located in the LOS drift responded to neutron activation of the LOS pipe and experiments. These units, RAMS Nos. 22 and 23, read 750 R/h and 500 R/h, respectively, immediately after detonation. Normal decay of this activation radiation was observed. All other RAMS units reflected background radiation levels. At 1258 hours, RAMS units Nos. 2 through 12 and No. 15 were functioning, showing only background readings. No indications of radioactive effluent were detected by any tunnel, surface, or airborne radiation monitoring units. All RAMS units were secured at 0800 hours on 14 May 1976, when RAMS unit Nos. 22 and 23 were reading 50 mR/h and 72 mR/h, respectively.

4.3.3 Initial Surface Radiation Surveys and Recovery Activities.

Four reentry teams (one team each to survey the main Mesa trailer park, Mesa interface trailer park, portal area, and portal area ventilation system) were released from Gate 300 at 1351 hours on the day of detonation. The portal area surveys were completed at 1432 hours, the main Mesa trailer park survey

was completed at 1435 hours, and the Mesa interface trailer park survey was completed at 1450 hours. No radiation levels above background (0.05 mR/h) were detected. During remote gas sampling, a trace of carbon monoxide was noted on the zero point side of the main OBP. A 0.1 mrad/h radiation level at contact with the sampling bag and a trace of carbon monoxide were noted from a sample taken remotely from inside the LOS pipe. Mesa and portal data recovery were conducted between 1645 and 1745 hours. D-day operations were terminated at 1810 hours.

4.4 POSTEVENT ACTIVITIES.

4.4.1 Tunnel Reentry Activities.

Remote gas sampling was again performed the morning of 13 May 1976 (D+1), before any personnel entered the tunnel. All surveys indicated normal air. At 0745 hours, a work party entered the tunnel bound for the gas seal door. No anticontamination clothing was required. The gas seal door was opened and the work party moved to the gas seal plug. Ventilation was established on the zero point side of this plug. A pump was set up to reduce the one-foot-deep water visible on the zero point side invert. Tracks were reinstalled through the gas seal door, and the work party returned to the portal at 0925 hours with no positive LEL, toxic gas, or above-background radiation level having been encountered.

Reentry team No. 1 entered the tunnel wearing full anti-contamination clothing, which included gloves, coveralls with openings taped, a hood, and totes. No respiratory protection was required to the OBP. At 0936 hours, the backup reentry team (team No. 2) and the rescue team entered the tunnel to set up a fresh air station at the gas seal plug. By 1010 hours, team No. 1 had reached the OBP. No toxic gas or positive LEL levels were observed, and all radiation readings were background, so ventilation was reestablished to the zero point side of the OBP. The team moved through the OBP at 1118 hours, each member wearing SCBA, and immediately reestablished the ventilation lines to the rest of the tunnel complex.

At 1137 hours, the team arrived at the LOS stubs area. The maximum exposure rate was 8 mR/h (gamma) near the left rib on the LOS pipe, with a maximum contact radiation level of 10 mrad/h (beta plus gamma). The team moved at 1143 hours to test chamber No. 1, and a reading made at contact with the test chamber door was greater than 200 mR/h. The general radiation level in the area was 140 mR/h. An exposure rate of 600 mR/h and 600 ppm of carbon monoxide were detected at arm's length inside the test chamber when the chamber door was opened slightly. Part of the team went into the ROSES units area at 1212 hours; no percentage of the LEL or toxic gas was measured, and the radiation level in the area was background. At 1340 hours, the team had moved to test chamber No. 3 and opened the door. A reading of 500 mR/h was taken at arm's length inside the door. A toxic gas level of 200 ppm of carbon monoxide, 0 percent of the LEL, and a 20 percent oxygen level were measured in the vent line over the chamber. At this point, team No. 2, dressed in full anticontamination gear and SCBA, replaced team No. 1 for the rest of the reentry.

At 1430 hours, the door to test chamber No. 2 was opened. Fifteen percent of the LEL and 500 ppm of carbon monoxide were measured, the oxygen content of the air was 21 percent (normal), and the radiation reading was 400 mR/h, each measurement taken at three feet inside the test chamber. Swipe samples were taken inside the chamber, which showed indications, when later analyzed, of some removable contamination in the LOS pipe. The door was reclosed, and the team moved on to assess damage to the rest of the LOS pipe and the tunnel complex and to recover designated equipment. At about 1,060 feet into the 10 bypass drift, water was noted coming from the left rib, and a sample was taken. All personnel returned to the portal by 1604 hours. The water sample taken was read with a portable Gieger-Mueller counter; only background radiation levels were noted. Reentry of the LOS pipe and test chambers remained to be completed the next day.

Recovery parties scheduled to go into the ROSES area at 1610 hours were not required to wear anticontamination clothing or

respiratory protection as all radiation, toxic gas, and LEL levels in that area were the same as those before the test. Personnel going to recover experiments in the LOS stubs area, from the test chamber No. 3 stubs, and from the air scatterer station were required to wear full anticontamination clothing. Full-face masks also were required in each area where the LOS pipe might be open. Radsafe monitors and industrial hygiene personnel escorted each recovery group into its respective area. Miners began excavating the gas seal plug during swing shift on D+1. Recovery personnel were checked out at 1955 hours at the "hot line." Some personnel showed minor levels of contamination on their skin and were decontaminated through washing of the affected area. Mining out the gas seal plug continued throughout the night.

At 0910 hours on 14 May 1976, a safety assessment team departed the portal into the tunnel. Part of this group included one Radsafe monitor, an industrial hygiene representative, and one miner. Members of this group were dressed in double anticontamination clothing and SCBA to reenter the LOS pipe to the TAPS door. Personnel not entering the TAPS area, but who were making a hazard and damage survey of the test chambers, were dressed in double anticontamination clothing and full-face masks with HEPA filters. Test chamber No. 3 was entered at 1000 hours; the exposure rate outside the test chamber was 60 mR/h, and the exposure rate inside the chamber was 130 mR/h. At 1015 hours, personnel dressed to reenter to the TAPS left the rest of the team, reaching the TAPS door at 1030 hours. A water leak was noted at the TAPS door. Zero percent of the LEL was noted, but 600 ppm of carbon monoxide was measured at the leak. The area exposure rate was 1 mR/h. In the vent line above test chamber No. 1, 300 ppm of carbon monoxide was noted, and inside the doors at test chamber Nos. 1 and 2, levels of 100 and 150 ppm of carbon monoxide, respectively, were observed. The safety assessment team returned to the portal at 1125 hours.

A work party entered the tunnel at 1330 hours on the same day to drain water flowing from behind the TAPS. A flange was removed from the zero point side of test chamber No. 3, and a

pump was set up. At 1,060 feet into the 10 bypass drift, water was pouring into the tunnel at the rate of four to five gallons a minute; at the LOS pipe, water was accumulating at the rate of three to four gallons per minute. Mining out of the gas seal plug and OBP was discontinued at 2000 hours because the water was building up. Radsafe monitors accompanied tunnel personnel during checks made at the OBP of the water buildup through 17 May. All area and water readings were background; no positive LEL or toxic gas levels were found.

On 17 May, water continued to drain into the drift. Miners once again began work at 0245 hours, however, to remove the gas seal plug and OBP. No radiation hazard existed so no anticontamination clothing was required. A LOS pipe reentry team wearing anticontamination clothing and SCBA departed from the portal at 1300 hours to go to the TAPS area. The radiation level outside test chamber No. 3 was 50 mrad/h (beta plus gamma). Inside the chamber, 85 mrad/h and 20 ppm of carbon monoxide were measured, but no positive LEL percentage was found. The carbon monoxide concentration measured at the TAPS was 400 ppm. Efforts to ventilate and clean up inside the LOS pipe on the zero point side of test chamber No. 3 continued into swing shift. Personnel cleaning up debris wore double anticontamination clothing and full-face masks. Tracks were laid through the OBP on swing shift, and a flex line was brought in to ventilate inside the LOS pipe.

Radsafe and SLA personnel in full anticontamination clothing and SCBA sampled the leak at the TAPS door on 18 May, and 100 ppm of carbon monoxide and 45 percent of the LEL were measured. Damage to the gas sampling valves in the door prevented taking measurements until the valves were repaired at 1545 hours. Ten percent of the LEL and 100 ppm of carbon monoxide were measured through the TAPS door at that time.

At 0820 hours on 19 May, a scientific assessment team dressed in double anticontamination clothing and full-face masks with HEPA filters entered the LOS pipe. Team members went into test chamber No. 3 at 1015 hours. The highest area exposure rate

encountered after entering all chambers was 3 mR/h, and the maximum reading at contact with the chamber interiors was 40 mR/h in test chamber No. 2. No toxic gas or positive LEL levels were observed. The scientific assessment team left the LOS pipe at 1040 hours, and LASL and Pan Am parties then entered the pipe to take photographs. Lockheed and SLA personnel went into the scatterer alcove for experiment recovery. (No toxic gases and a 0.2 mrad/h radiation level were measured.) All experimenter personnel wore full anticontamination clothing and full-face masks. All personnel were out of the pipe with their experiments at 1710 hours.

Miners cleaned up and rehabilitated the LOS pipe and crosscut areas on 20 May. Various personnel requested tours of the LOS pipe; each person entering the pipe during this time was required to wear two pairs of totes, single pairs of coveralls and gloves, and a full-face mask with HEPA filter. LASL personnel conducted radiography in test chamber Nos. 1, 2, and 3 during the entire swing shift and part of graveyard shift.

Recoveries continued on 21 May and a Radsafe station was set up inside the tunnel. A survey inside the LOS pipe showed a 2 mR/h exposure rate, no toxic gases, 0 percent of the LEL, and a 21 percent oxygen level. The exposure rate outside the pipe had decreased to background. Experiment removal and photography were conducted until 1300 hours. Experiment recoveries continued on 24 and 25 May with full anticontamination clothing required, including double totes and full-face masks.

On 26 May, pipefitters assisted recovery personnel in removing experiments and then installed a valve in the TAPS door. Miners continued to do cleanup and rehabilitation work throughout this period.

On 27 May, a check was made behind the TAPS door; 2,800 ppm of carbon monoxide and greater than 100 percent of the LEL were measured. Limited ventilation was established behind the door. On 28 May, recovery of equipment and experiments continued. All effects experiments were recovered from test chambers by 28 May.

On 1 June 1975, readings from the zero point side of the TAPS door were taken. Results showed 500 ppm of carbon monoxide and 7 percent of the LEL were present. At 1215 hours, the TAPS door was opened by pipefitters wearing full anticontamination clothing, and water started running from behind the door. A pump was rigged up to drain this water. At 1520 hours, personnel entered the pipe and were able to walk to DAC No. 1; both the pipe and the experiments appeared in good condition. The radiation level at test chamber No. 4 was 6 mrad/h. A trace of carbon monoxide and 10 percent of the LEL also were measured. Experiment recovery continued with full anticontamination clothing and full-face masks required.

On 2 June, the Pan Am photographer entered test chamber No. 4 to take pictures. Miners continued to work on the OBP. All experiments had been removed from test chamber No. 4 on 3 June. This completed all recoveries that could be made at this time. (Additional recoveries of experiments were made as reentry mining progressed.)

Drilling of holes through the DAC No. 1 door began on 4 June. Pipefitters wearing full-face masks with supplied air drilled through the top of the DAC at 1025 hours. Greater than 100 percent of the LEL and 800 ppm of carbon monoxide were detected through the hole. The radiation level was 4 mrad/h. A second hole was drilled, through which water poured. It was noted that the DAC had not closed properly.

4.4.2 Postevent Mining.

Mining began on 7 June 1975 at about 1,370 feet into the 10 bypass drift to (1) recover special experiments, (2) recover LOS pipe and equipment to be used on the DIABLO HAWK event, and (3) facilitate underground core sampling operations. During this mining, an 18- to 22-foot probe hole was drilled in the face before each round was loaded to establish what conditions would exist after the round was fired (presence of water, radiation, or other hazards). The rock excavated (muck) by each blast or by mining equipment was surveyed for radiation levels.

Work continued through 7 September 1975 with no radiation encountered during mining and mucking operations. Throughout this period, mining personnel were preparing the LOS pipe for removal and reuse during the forthcoming DIABLO HAWK event. Five reentry drifts (called the A & B reentry drift, A crosscut, B crosscut, bypass reentry drift, and DAC No. 1 crosscut, see Figure 4.5) were mined. Some positive radiation readings were encountered during removal of the LOS pipe and related equipment, and some ventilation problems occurred. Precautions, including full anticontamination clothing and full-face masks with supplied air or HEPA filters, were implemented as required during mining and removal operations.

On 23 September 1975, mining of the interface reentry drift began at 1,609 feet into the 10 bypass drift. Above-background radiation levels were noted during this mining operation, and anticontamination clothing requirements including coveralls, gloves and miner's boots were required inside the "hot line." This mining was conducted simultaneously with preevent DIABLO HAWK mining. Work on the interface reentry drift continued through 7 April 1977.

4.4.3 Postevent Drilling.

In the process of locating and mining out experiments and equipment from the MIGHTY EPIC reentry drifts, an extensive system of probe and exploratory holes were drilled. During drilling, each one of these holes was monitored daily by Radsafe personnel. Some holes showed above-background radiation readings, but the anticontamination clothing requirement inside the "hot line" already included coveralls, gloves, and miner's boots so no new requirements were necessary except for special areas and situations. The use of full-face masks and supplied air equipment was implemented as needed. There were two efforts underground to obtain core samples from the zero point (RE No. 1 and 2) and a Mesa drillback operation which are described below.

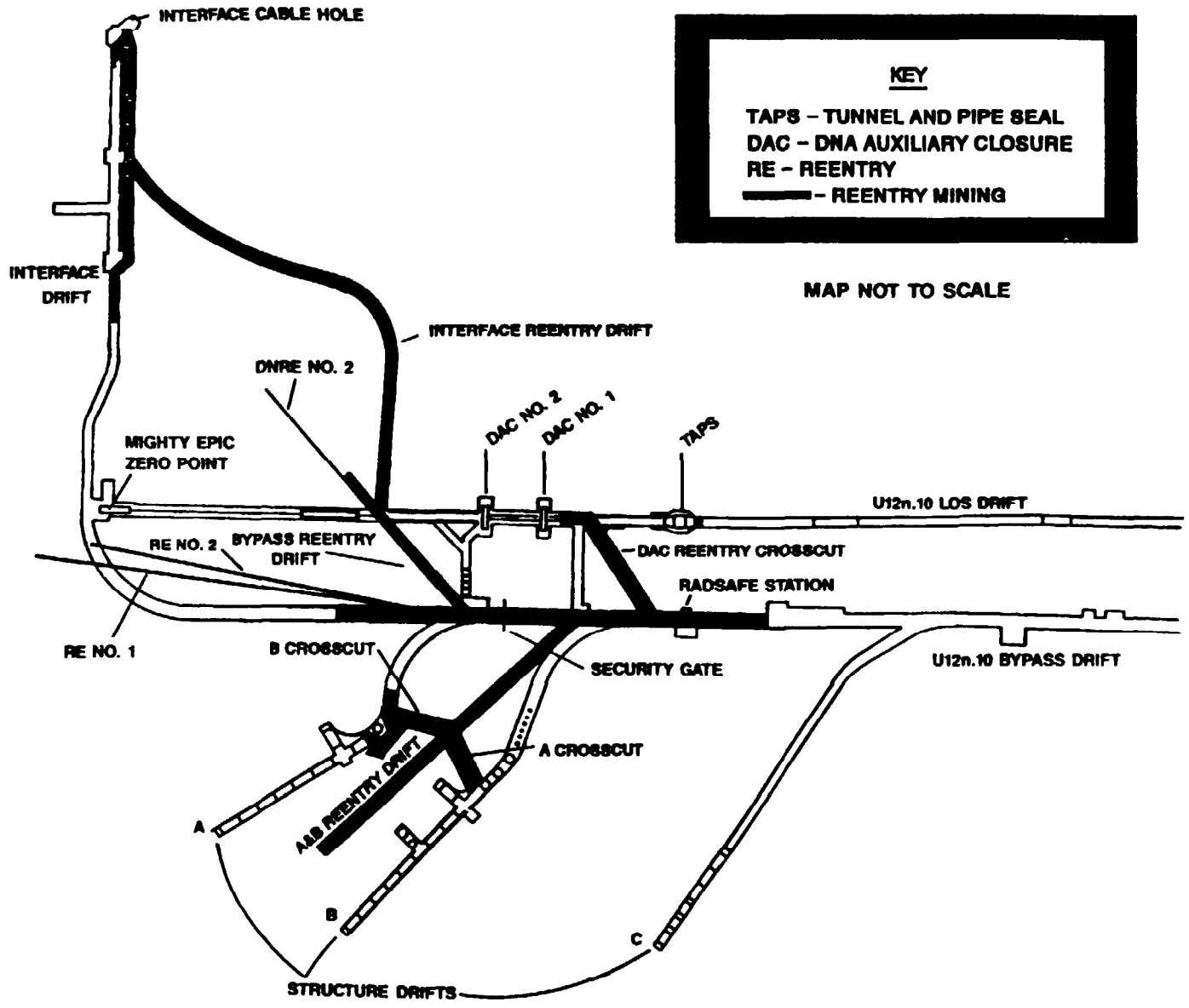

Figure 4.5 MIGHTY EPIC event - postevent reentry mining and coring locations.

Preparations began underground on day shift, 11 August 1976, to investigate the event chimney and retrieve core from the MIGHTY EPIC zero point area. Drilling on RE No. 1 finally began on 17 August, delayed because of various equipment problems. Drillers and personnel in the core removal area dressed in coveralls, totes, and gloves to begin operations, and a "hot line" was set up just inside the area security gate. (See Figure 4.5 for the location of the security gate and "hot line.") The first measurable radiation from this hole was 14 mrad/h at a drilling depth of 40 feet. The work area radiation level increased to 0.15 mrad/h. One of the drillers contaminated his street clothes, in spite of the anticontamination clothing he wore, so a requirement of rain slickers was added to the other radiation protection clothing prescribed. The highest reading encountered during coring was 2.9 R/h, measured on core from a drilling depth of 99 feet, 3 inches into the hole. A sandbag dam was built at this time near the security gate to inhibit the spread of contaminated drilling water through the tunnel. The total depth of the core hole was 226 feet, which was reached at 1315 hours on 25 August. The highest radiation level noted in the work area was 160 mrad/h, measured at contact with the invert on 19 August 1976.

Mesa drilling operations to investigate the chimney and cavity began on 23 August 1976 and were terminated on 4 September. Coring was performed, but no core with above-background radiation levels was obtained. Tests were run to see if tracer gas injected into the cavity through RE No. 1 could be detected through the Mesa drill hole. The hole was capped off 10 November 1976. No exposures to personnel occurred during these tests.

A second cavity core retrieval effort was begun 14 October 1976. RE No. 2 was started close to where RE No. 1 had been drilled in the 10 bypass drift, so anticontamination clothing including coveralls, gloves, and miners boots was a requirement from the beginning of this operation. The work area radiation level was 1 mrad/h because the activity of the contaminated water from RE No. 1 drilling operations remained.

The first indication of radiation from RE No. 2 was at about 84 feet into the hole, where a radiation level of 15 mrad/h was measured on the retrieved core. Although the work area radiation level continued to be only 1 mrad/h, a check of the core hole showed the presence of 500 ppm of carbon monoxide and 50 percent of the LEL at the drill hole opening, so drillers and safety personnel were required to wear supplied-air masks from that time forward. The highest radiation level detected on a core was 70 mrad/h, measured on core pulled from about 100 feet into the hole on 18 October. The work area radiation level remained at 5 mrad/h until this core was removed from the area. The highest contact radiation level measured during coring was greater than 200 mrad/h, measured near the returned drill circulation water while near the 100-foot drilling depth. By swing shift on 18 October, the work area radiation level had dropped to 0.1 mrad/h, and it did not increase above 2 mrad/h during the rest of coring. On 28 October at 0645 hours, coring operations were discontinued at a total drilling depth of 175.2 feet. Valves eventually were installed on both of these reentry holes to prevent flow of air in or out of the cavity area. Cavity pressure-checking operations were conducted using these valves in November 1976 and in March 1977.

A third reentry coring operation was conducted; core hole DNRE No. 2 (shown in Figure 4.5) was begun 5 November 1976. The highest work area exposure level noted was 0.2 mrad/h, which was caused more by the proximity of the drilling rig to the MIGHTY EPIC LOS pipe than by the radioactivity of the core retrieved. No core exceeded a radiation level of 2 mrad/h, and most of the core was at the background level. Work was completed on this hole on 10 November 1976.

4.4.4 Industrial Safety.

Checks for the presence of toxic gases and surveys to measure radiation and LEL levels were made on each shift. The results were then recorded in the monitors' logbook.

Appropriate safety measures were taken to protect mining personnel and prevent unsafe conditions. Industrial safety codes, including specific codes for mining, tunneling, and drilling, were established by REECO and emphasized during all operations. A written standard operating procedure was required for each operation involving explosives, toxic materials, radioactive material, or any other operation with the potential for personal injury. Each individual involved in such an operation was required to know the contents of the applicable procedures.

The portal construction area and the tunnel were mandatory hard hat and foot protection areas (safety shoes, safety boots, ERDA-issued miner's boots, or toe guards). All personnel on the initial tunnel reentry teams were certified in the use of the Draeger self-contained breathing apparatus and had used the McCaa two-hour breathing apparatus. Standard safety rules and regulations, as specified in the "U.S. Bureau of Mines Manual," were observed. HEPA canister filters were supplied routinely for hazardous situations where full-face masks were required. An array of specialized canister filters could be obtained upon request for special hazardous situations.

All explosives, electro-explosive components, solid propellants, toxic materials, and radioactive materials were handled, stored, and transported in accordance with applicable sections of the following documents:

1. Army Materiel Command Regulations (AMCR 385-224).
2. AEC Manual 0500 Series for the Nevada Test Site.
3. Individual Safe Operating Procedures (by experimenter organization).
4. MIGHTY EPIC Safety Regulations.

All personnel engaged in handling, storing, assembling, or installing explosives, propellants, or electro-explosive devices (or observers of those operations) were required to wear safety glasses or other eye protection which had been approved by the DOD Safety Coordinator.

4.5 RESULTS AND CONCLUSIONS.

Telemetry measurements began at 1251 hours on 12 May 1976 and all telemetry stations were secured at 0800 hours on 14 May 1976. No radiation other than that from usual activation products was detected by telemetry units.

The initial radiation surveys of the Mesa and portal areas began at 1351 hours on 12 May and were completed by 1435 hours. No radiation above background was detected at the Mesa trailer park or at the tunnel complex portal.

Reentry into the tunnel began with a work party at 0745 hours on 13 May 1976. The maximum reading during reentry operations was 600 mR/h, detected at arm's length inside test chamber No. 1 on 13 May. The maximum toxic gas concentration and LEL levels were 2,800 ppm of carbon monoxide and greater than 100 percent of the LEL, respectively, measured behind the TAPS door on 27 May.

On 7 June, reentry mining operations began in the U12n.10 bypass drift. A total of six reentry drifts were mined to implement equipment and experiment recovery operations. Reentry mining efforts continued through 7 April 1977. Some radiation was encountered during removal of portions of the LOS pipe and related equipment.

An underground core sampling operation was conducted between 11 August and 25 August 1977. The maximum reading on core from this hole was 2.9 R/h at a depth of about 99 feet into the hole. The highest radiation level recorded in the work area was 160 mrad/h, taken at contact with the invert on 19 August. During a second underground drilling operation conducted between 14 October and 28 October 1976, another core hole was drilled toward the MIGHTY EPIC zero point. The highest radiation level noted on this core was 70 mrad/h, measured on core retrieved from about 100 feet into the drill hole. Drilling and safety personnel were required to wear supplied-air equipment throughout most of this

drilling effort because of the 200 ppm carbon monoxide and 50 percent LEL levels measured near the drill hole opening. The highest radiation level noted in the work area was greater than 200 mrad/h, measured at contact with returned drill circulation water. These underground radiation areas were controlled by the "hot line" set up inside the area security gate. Drilling on the Mesa to recover core was conducted from 23 August until 4 September, but no core samples above background were retrieved.

Personnel exposures during individual entries to MIGHTY EPIC radex areas from 2 May to 28 October 1976, when use of the Area Access Registers was discontinued, are summarized below. Average exposures are from self-reading pocket dosimeters as recorded on the Area Access Registers. Maximum exposures are from film dosimeter records.

	No. of Entries Logged	Maximum Exposure (mR)	Average Exposure (mR)
All Participants	624	90	4.8
DOD Participants	485	0*	4.6

*The minimum detectable radiation exposure which could be measured by the NTS film badge dosimeter was 30 mR; an exposure of zero means any exposure received was below this level.

SECTION 5

HYBLA GOLD EVENT

5.1 EVENT SUMMARY.

HYBLA GOLD was a DOD-sponsored test conducted at 1005 hours Pacific Standard Time (PST) on 1 November 1977 with a yield of less than 20 kilotons. The device was detonated in the U12e.20 drift of the E tunnel complex (Figure 5.1) at a vertical depth of 1,263 feet. The purpose of the event was to test the response of materials and equipment to a nuclear detonation environment and to obtain basic physics data related to blast and electromagnetic pulse generation for MX trench exposure in the source region. Five concrete pipes with varying types of surfaces were used to ascertain how the medium a missile would pass through during launch would affect the missile shell and trajectory. DOD and supporting organizations fielded 10 projects for this test.

A minor stemming leak was observed but was contained completely by closures and secondary tunnel stemming. No radioactive effluent from the test was detected onsite or offsite.

5.2 PREEVENT ACTIVITIES.

5.2.1 Responsibilities.

Safe conduct of all HYBLA GOLD project activities in Area 12 was the responsibility of the DOD Test Group Director. Responsibilities of DOE* and DOE contractor personnel were in accordance with established DOE-DOD agreements or were the subject of separate action between Field Command/DNA, and the DOE Nevada Operations Office (DOE/NVOO).

*DOE succeeded ERDA on 1 October 1977.

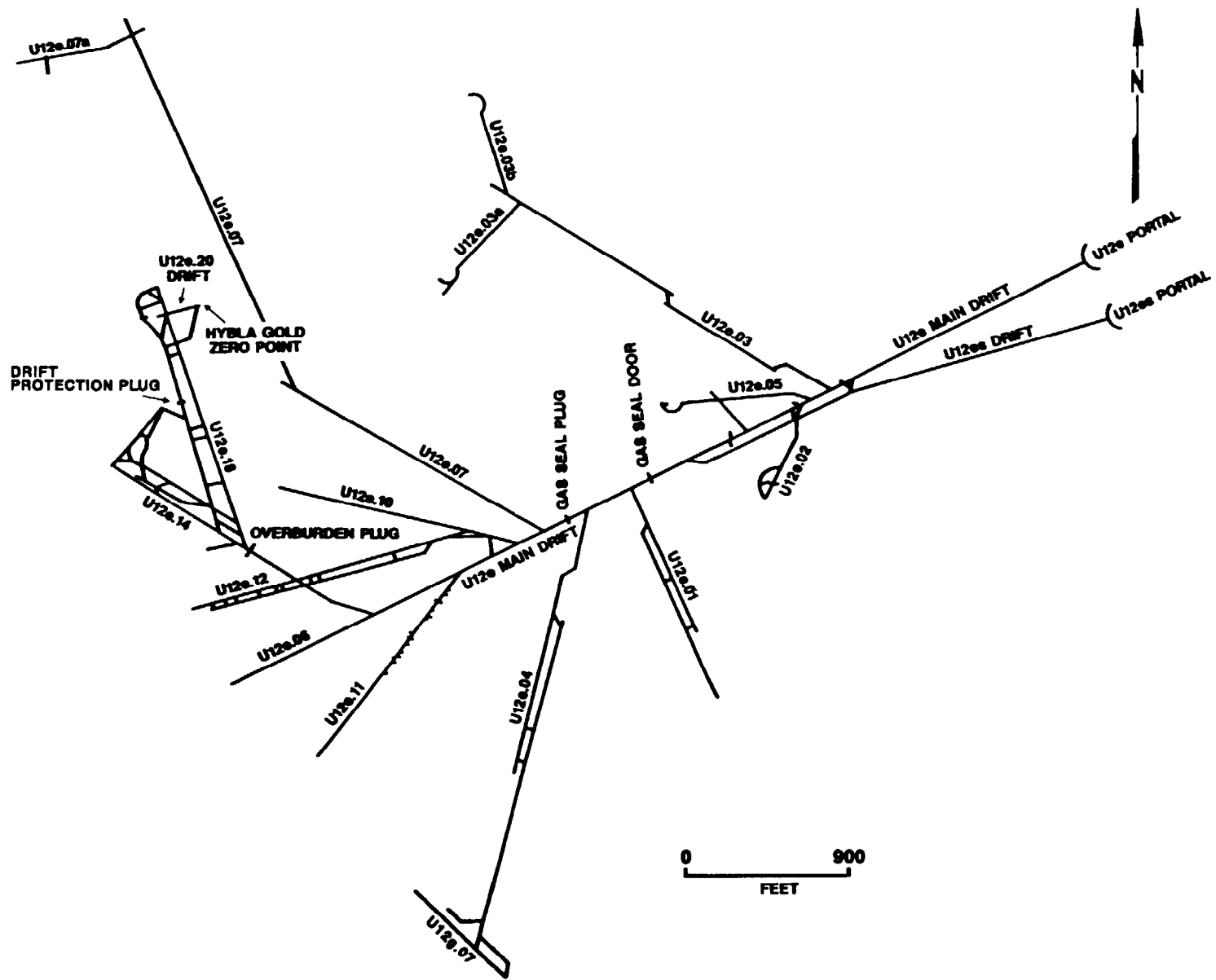

Figure 5.1 HYBLA GOLD event - tunnel layout.

Project agencies were responsible for designing, preparing, and installing experiments or delivering them to the installation contractor. After the event, these agencies were responsible for removing samples, analyzing instrument and sample data, and preparing project reports on experiment results.

Device safety and security procedures in the zero point area and the timing and firing control room were in accordance with ERDA Manual Chapter 0560*, "Program to Prevent Accidental or Unauthorized Nuclear Explosive Detonations." Because LASL fielded the device, the LASL Test Group Director was responsible for radiological safety within a 6,000-foot radius of the zero point from device emplacement until detonation. After detonation, the DOE Test Controller relieved the LASL Test Group Director of responsibility. When the Test Controller determined that venting had not occurred, he delegated responsibility for radiological safety to the DNA Test Group Director.

5.2.2 Planning and Preparations.

A. Tunnel Facilities Construction.

This test was an experiment to study aspects of the MX missile system. The test was designed to collect physics information on shock front transit in concrete pipe and to study the effects of surface roughness, wall ablation, and expansion on this transit. Five pipes would terminate in a zero room containing a nuclear device, which, upon detonation, was designed to drive a strong air blast down each pipe. (See Figures 5.2 and 5.3.)

The HYBLA GOLD test complex utilized parts of the DINING CAR (1975) bypass drift, reentry drift, and associated alcoves. A new main and auxiliary drift were excavated to provide the desired pipe configuration. Two DNA

*ERDA Manual Chapter 0560 was superseded by DOE Order 5610.3 in December 1981.

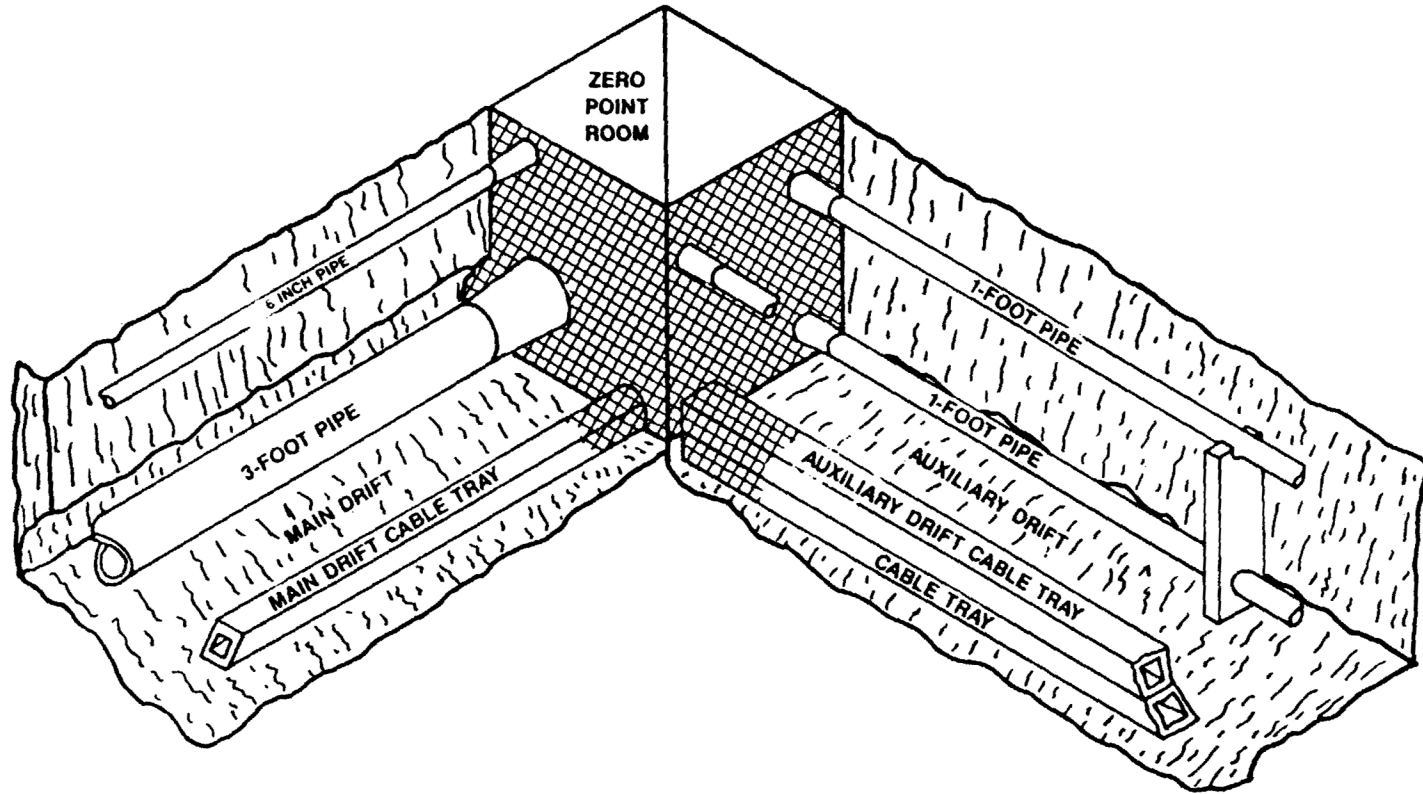

Figure 5.2 HYBLA GOLD event - experiment pipes.

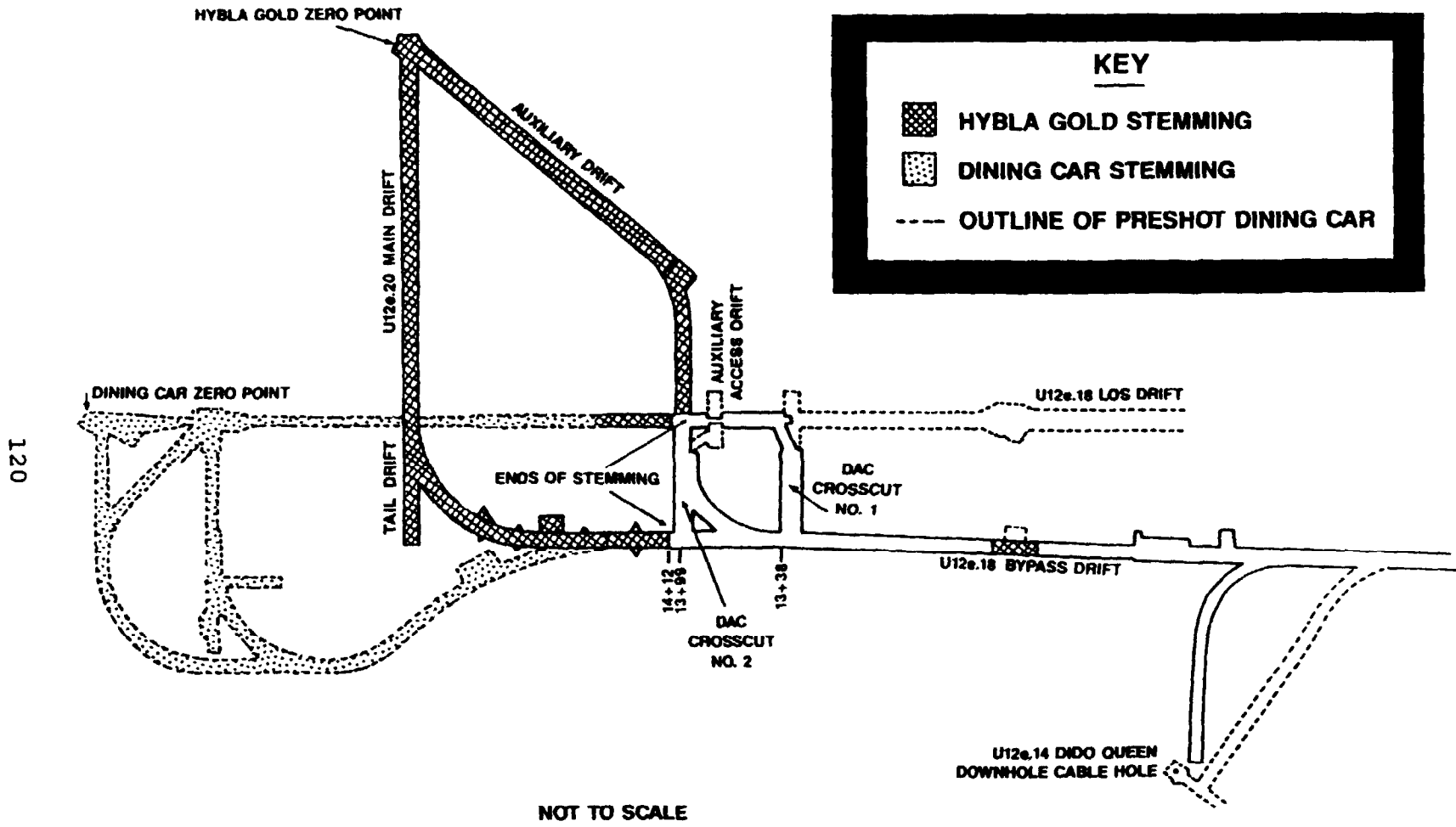

Figure 5.3 HYBLA GOLD event - drift plan.

Auxiliary Closures (DAC Nos. 1 and 2) were located in the U12e.18 LOS drift. The DINING CAR TAPS (in the U12e.18 LOS drift) was welded shut before the HYBLA GOLD event to prevent leakage from the U12e.18 LOS drift through the DINING CAR LOS pipe. The OBP was located in the U12e.14 drift as it had been for the DINING CAR (1975) and DIDO QUEEN (1973) events.

Test cables generally were routed from the ground zero area through the respective pipe drifts (20 main or auxiliary) into the experimenter alcove, through the cable gas block at the OBP to the downhole alcove splice rack, from there to the cable gas block in the Mesa splice room, and finally into a Mesa recording trailer. Some recording trailers also were placed at the E tunnel portal. The gas seal plug also was placed as it had been for the DIDO QUEEN and the DINING CAR events. The gas seal door had been installed in the U12e main drift prior to the DORSAL FIN (1968) event was reused during the HYBLA GOLD event.

Remote gas sampling lines were installed to sample air from the vent lines at the portal; zero point sides of the OBP, gas seal plug, and gas seal door; and portal sides of the OBP and drift protection plug (DPP). Manual gas sampling facilities were placed to take air samples from the zero point sides of the gas seal door, the gas seal plug, the OBP, and the DPP.

Mining of the U12e.20 drift was started 11 March 1977 and was completed by the end of April 1977. Zero room excavation and the auxiliary drift were completed by the end of June. The concrete experiment pipes, installation of experiments, and containment construction were completed by September 1977.

An MFP dry run was conducted 6 October, and a successful post stemming MFP was conducted on 13 October 1977. Experimenters represented in the test included KSC; SRI;

SSS; Thompson, Ramo and Woolridge, Incorporated (TRW); and SLA.

B. Radiological Safety Support.

Procedures for radiation exposure and contamination control during this event were in accordance with ERDA Manual Chapter 0524* and requirements of responsible DOD representatives. Radsafe provided monitoring and equipment support.

Prior to the test, detailed radiological safety reentry plans were prepared and issued to participating agencies. Air sampling equipment was positioned in the test area. Radsafe monitors were briefed regarding surface reentry, manned stations, and security station requirements.

Radsafe monitoring teams and supervisory personnel were provided to perform initial radiation surveys, conduct aerial surveys by helicopter, and participate in reentry parties as needed. Radsafe personnel also were standing by at Gate 300 prior to detonation to perform surveys and provide emergency support as directed; provide and issue anticontamination equipment and material, portable instruments, and dosimeters; operate area control check stations; and perform personnel, equipment, and vehicle decontamination, as required.

Available anticontamination materials and equipment included head covers, coveralls, cloth shoe covers, totes, full-face masks, supplied-air breathing apparatus, plastic suits, plastic bags, gloves, and masking tape.

*ERDA Manual Chapter 0524 was in effect until May 1980 when it was superseded by DOE Order 5480.1

C. Telemetry and Air Sampling Support.

In addition to permanent RAMS units, 39 temporary units provided surface and underground coverage for HYBLA GOLD as shown in Table 5.1 and Figures 5.4 and 5.5. Also, an air sampling unit was placed at the tunnel portal. All RAMS units and the air sampling unit were installed a minimum of five days prior to scheduled device detonation.

EPA operated 48 air sampling stations and 11 gamma rate recorder stations in the offsite area. Thermoluminescent dosimeters (TLDs) also were placed to verify offsite radiation levels. Twenty-three EPA personnel were fielded for offsite surveillance activities.

D. Security Coverage.

Device security procedures in the zero point area and the timing and firing control room were in accordance with ERDA Manual Chapter 0560, "Program to Prevent Accidental or Unauthorized Nuclear Explosive Detonations." Beginning on D-1, all personnel entering or exiting the controlled area were required to stop at muster or control stations for issue of stay-in badges, or issue and return of muster badges. After area control was established, all through traffic was diverted around the controlled area by use of screening stations.

In accordance with the "Test Controller's Operations and Security Plans," contractors and agencies were to have all personnel not connected with this event out of the closed area before the final security sweep began.

Table 5.1. HYBLA GOLD event RAMS unit locations
1 November 1977.

SURFACE

Station	Location
	<u>From the U12es portal:</u>
1	On the filter system
2	On the vent line
3	On the vent line
4	897 feet N 13° E azimuth
5	572 feet N 62° E azimuth
6	476 feet S 71° E azimuth
7	382 feet S 22° E azimuth
8	415 feet S 34° W azimuth
9	492 feet N 44° W azimuth
10	870 feet N 22° W azimuth
11	On the tunnel drain line (at the U12es portal)
12	1,885 feet N 89° E azimuth
	<u>From the cable downhole:</u>
13	At cable downhole
14	209 feet N 04° E azimuth
15	275 feet S 88° E azimuth
16	190 feet S 08° E azimuth
17	235 feet S 87° W azimuth
	<u>From the U12e.20 SGZ:</u>
18	500 feet due north
19	500 feet S 60° E azimuth
20	500 feet S 60° W azimuth

Table 5.1. HYBLA GOLD event RAMS unit locations
1 November 1977 (Continued).

UNDERGROUND

Station	Location
	<u>From the U12e.14 drift unless otherwise indicated:</u>
21	1,400 feet into the U12e.18 bypass drift
22	90 feet into the DAC No. 2 crosscut from the U12e.18 bypass drift
23	1,200 feet into the U12e.18 bypass drift
*24ER	1,200 feet into the U12e.18 bypass drift
25	1,180 feet into the U12e.18 LOS drift
26	1,100 feet into the U12e.18 bypass drift
27	600 feet into the U12e.18 bypass drift
28	350 feet into the U12e.18 LOS drift
	<u>From the U12e.06 drift unless otherwise indicated:</u>
29	1,050 feet into the U12e.14 drift
*30ER	1,050 feet into the U12e.14 drift
31	450 feet into the U12e.14 drift
32	500 feet into the U12e.12 reentry drift from the U12e 10 drift
33	700 feet into the U12e.06 drift from the U12e main drift
	<u>From the U12e portal unless otherwise indicated:</u>
34	3,800 feet into the U12e main drift
*35ER	3,800 feet into the U12e main drift
36	3,500 feet into the U12e main drift
37	2,500 feet into the U12e main drift
38	50 feet into the U12e main drift
39	95 feet into the U12es drift from the U12es portal

* ER - Extended Range (instrument capable of reading 100 mR/h to
100,000 R/h)

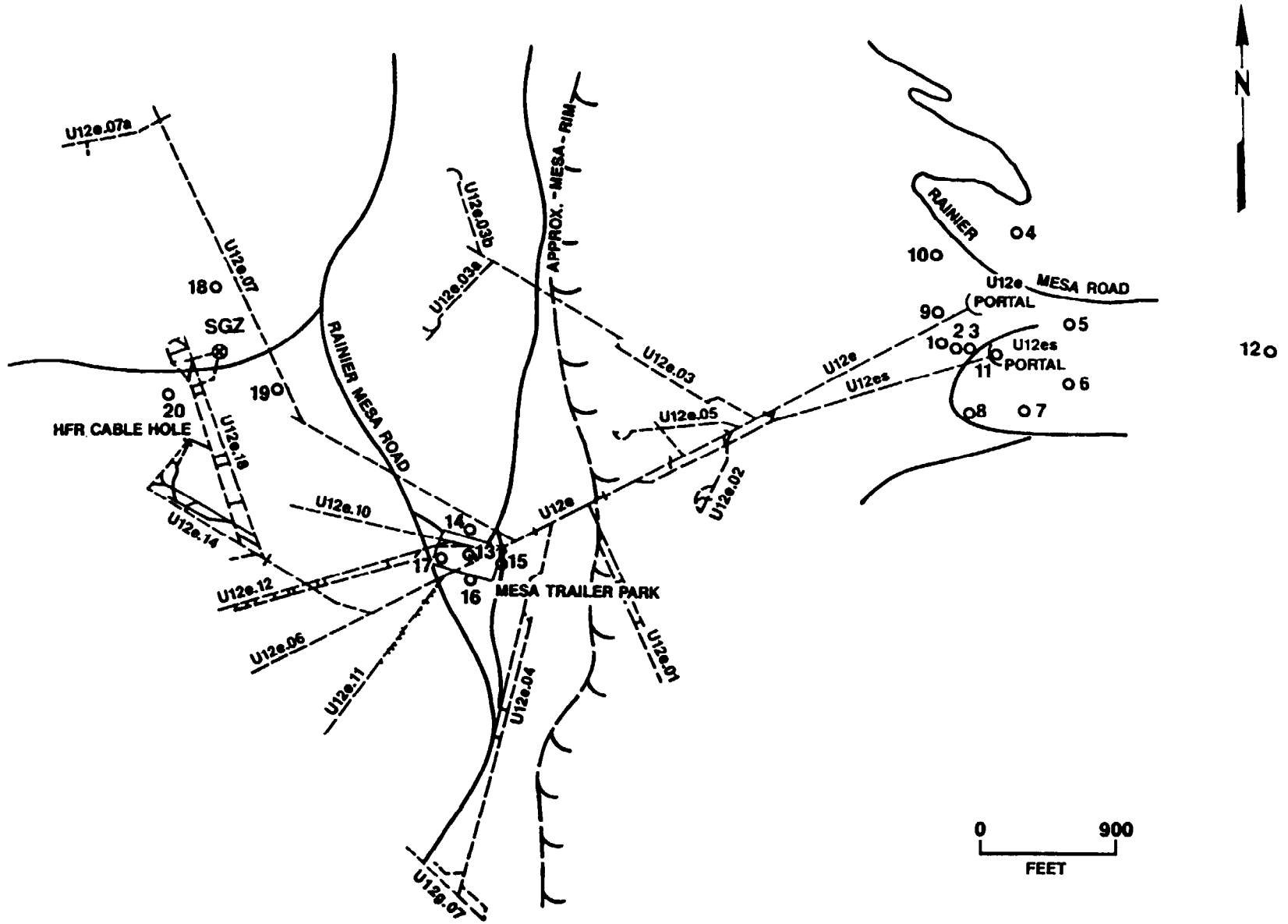

Figure 5.4 HYBLA GOLD event - surface RAMS.

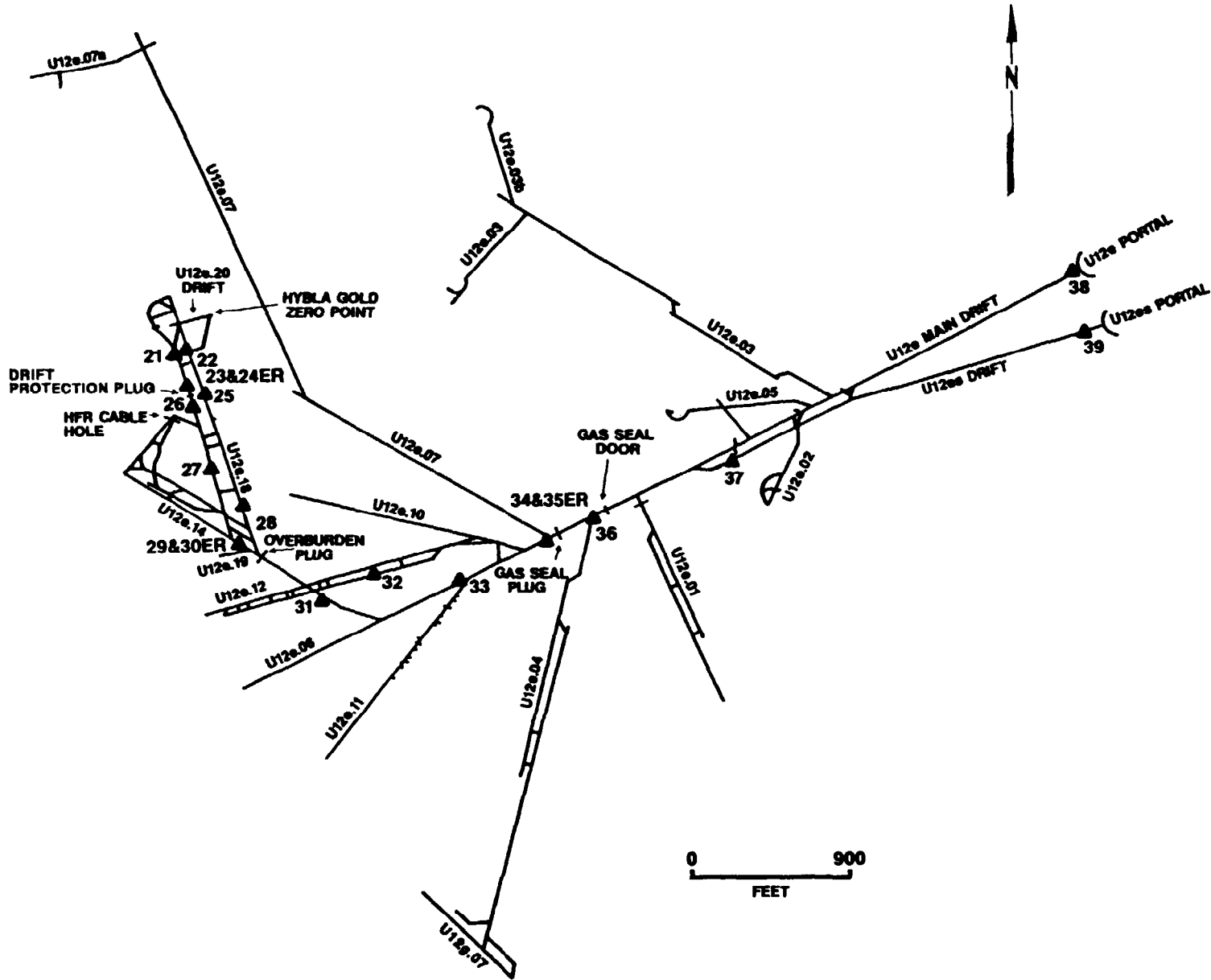

Figure 5.5 HYBLA GOLD event - underground RAMS.

E. Air Support.

Two UH1N helicopters and crews were provided by the USAF for cloud tracking and the Test Controller's use, if needed. In addition, the USAF provided a C-130 and crew on standby status for cloud tracking. The EPA provided a Turbo Beech and crew for cloud sampling. Another EPA aircraft (C-130) was standing by in Las Vegas to undertake tracking duties, if required.

5.3 EVENT-DAY ACTIVITIES.

5.3.1 Preshot Activities.

At 0001 hours, all persons except the arming party, tunnel button-up party, microwave timing party, and security guards were out of the tunnel and clear of the muster area. Permission was granted to arm the device, and button-up was completed.

A readiness briefing was held at 0800 hours in anticipation of planned test execution about 1000 hours that day. Conditions for test execution were favorable, and all personnel were mustered out of the area. The 15-minute countdown started as planned at 0950 hours PST and proceeded through zero time.

The HYBLA GOLD device was detonated at 1005 hours PST on 1 November 1977.

5.3.2 Test Area Monitoring.

Telemetry measurements began at 1006 hours on 1 November 1977. Only RAMS unit Nos. 21, 22, and 23 showed above-background radiation readings because of a minor stemming leak. Normal radioactive decay of these levels was observed. All other RAMS units reflected background radiation levels. No indications of radioactive effluent were detected by any other tunnel, surface, or airborne radiation monitoring unit. RAMS unit Nos. 1 through 20, 24ER, 25, 30ER, and 31 through 39 were secured at 1430 hours on 2 November 1977. The remaining 12 stations were secured at

about 1300 hours on 15 November 1977. A summary of the RAMS indications of the stemming leak is as follows:

<u>RAMS Unit No.</u>	<u>Increased Readings First Noted</u>	<u>Maximum Reading Noted</u>	<u>Time of Maximum Reading</u>
21	Between H+8 and H+9 mins.	3.8 R/h	H+33 mins.
22	H+22 mins.	280 mR/h	H+33 mins.
23	H+37 mins.	18 mR/h	H+7 hours

5.3.3 Initial Surface Radiation Surveys and Recovery Activities.

Three reentry teams (one team each to survey the Mesa trailer park, the portal area, and the portal area ventilation system) were released from Gate 300 at 1113 hours on the day of detonation. Surveys of all areas were completed at 1205 hours. No radiation levels above background (0.05 mR/h) were detected. The survey teams stood by, and gas samples were obtained remotely from various points inside the tunnel. All gas samples taken on the portal side of the DPP showed normal air. Gas samples on the zero point side of the DPP reflected 5 percent of the LEL, 10 ppm of carbon monoxide, and a radiation level of 80 mrad/h (beta plus gamma). Mesa and portal data recovery were conducted until 1430 hours. D-day operations were terminated at 1600 hours.

5.4 POSTEVENT ACTIVITIES.

5.4.1 Tunnel Reentry Activities.

Gas sampling again was conducted the next morning (D+1). The highest readings obtained were from the zero point side of the OBP, which included 10 ppm of carbon monoxide, 3,000 ppm of carbon dioxide, 3 percent of the LEL, and a 1.7 mrad/h radiation level. The ventilation system was restarted, providing fresh air to the gas seal door.

No reentry was made into the tunnel until 3 November (D+2). The initial tunnel reentry was made in three stages: reentry to

the gas seal plug was conducted on 3 November, on 14 November reentry past the DPP was made, and on 29 November reentry was made into the DINING CAR LOS pipe on the portal side of the TAPS and the U12e.20 main and auxiliary drifts.

Two teams (team No. 1 and the rescue team) entered the portal at 0923 hours on 3 November aboard the train, reaching the gas seal door at 0935 hours. The teams members were dressed in anticontamination clothing, but no self-contained breathing apparatus (SCBA) was required. Air from the zero point side of the gas seal door was sampled; zero percent of the LEL, no toxic gases, and only background radiation were observed from the sample. The team proceeded to open the access door. Water six inches deep was observed on the invert on the zero point side of the gas seal door, so a valve in the plug was opened to drain the water. A water sample was taken, but no above-background radiation levels were observed.

Team No. 1 then moved through the gas seal door. Again the air was sampled; no toxic gas or positive LEL was noted, and a radiation level of 0.06 mrad/h was observed. The team continued towards the gas seal plug, reaching it at 0950 hours. Air was sampled through the plug. No above-background radiation or LEL level was observed, but 2,000 ppm of carbon dioxide was noted. At 0957 hours, the team began to open the 24-inch manway door. The vent line was hooked up to provide suction around the door. The 24-inch door was opened at 1005 hours, and work began to open the 36-inch manway door. At 1012 hours, the 36-inch door was opened and a team member passed through the crawl space to check for water on the zero point side. Water was observed on the invert about one foot below the bottom of the manway door. A water sample was taken, ventilation to the zero point side of the plug was verified, and the team returned to the gas seal door to ride to the portal on the train. The team was out of the tunnel by 1042 hours. No SCBA was worn on this reentry.

Tunnel personnel began work on 3 November to open the gas seal door and mine out the gas seal plug. The tunnel was open to

the OBP by 11 November. No toxic gas, positive LEL, or above-background radiation level was encountered during this work effort.

Team No. 1 again entered the tunnel on 14 November to continue reentry activities. The team departed the portal at 0903 hours. Team members were briefed at the gas seal plug, and they started toward the OBP at 0921 hours, each equipped with SCBA but not wearing it. The condition of the tunnel generally was good all along the tunnel to the OBP. At 0932 hours, the team reached the OBP with no positive LEL or toxic gas measurements and radiation surveys reflecting background levels. Sampling behind the OBP commenced; no above-zero LEL or above-background radiation level was noted from these air samples, but a positive toxic gas reading of 500 ppm of carbon dioxide was observed. At 0940 hours, work was begun to open the 24-inch manway door. The door was opened slightly, and a survey verified that no radiation, toxic gas, or LEL levels above background existed in the crawl space. Work began to open the 36-inch manway door, but mechanical problems with the hydraulic system prevented opening of door on the portal side of the crawl space. One of the team members got hydraulic fluid in his eyes, so all members of the team returned to the portal at 1039 hours.

Another miner was selected to replace the injured team member, and the reentry team returned inside at 1050 hours. The door on the portal side of the 36-inch manway continued to be a problem. The team worked, without SCBA, until 1215 hours when the door was opened. The ventilation system was connected to the 24-inch manway to establish ventilation between the OBP and the DPP. Opening the 36-inch manway door on the zero point side of the plug now became a problem. At 1243 hours, ventilation through the 24-inch crawl space was discontinued so that two team members could crawl through the plug to try to manually open the manway door from the zero point side. Both team members were wearing supplied-air equipment with full-face masks. At 1319 hours, the door was opened, and ventilation was reestablished before the team took a break for lunch.

At 1357 hours, the reentry team donned their SCBA and, by 1403 hours, had passed through the manway to the zero point side of the OBP. Some damage was observed. The team moved through the 18 bypass and reached the U12e.18 LOS drift (DINING CAR) TAPS area at 1421 hours. No above-zero LEL or toxic gas level was noted, but a radiation level of 0.07 mrad/h (beta plus gamma) was observed. Air from the zero point side of the TAPS was sampled. No LEL or toxic gas level was observed, and radiation readings were at background levels. Team members were proceeded to the DPP, reaching it at 1438 hours. No indications of any LEL percentage or toxic gas level were found at the plug, and a radiation level of 0.08 mrad/h was noted. Team members were allowed to remove their face masks at 1459 hours. By 1530 hours, all members of the team had returned to the portal. Work to remove the OBP began on 15 November and continued until 28 November.

On 29 November 1977, the third phase of the reentry was begun. Team No. 1 and the rescue team left the portal at 0906 hours in full anticontamination clothing. At 0915 hours, team members arrived at the OBP and donned SCBA with the intention of reentering the area on the zero point side of the DPP. The team reached the DPP at 0936 hours. An air sample was taken from the zero point side of the DPP before reentry was permitted to continue. No LEL or toxic gas level was noted, and the radiation level was 0.04 mrad/h. The team was instructed at this time to go to the portal side of the U12e.18 LOS drift TAPS. The gas sampling line was opened at the TAPS; zero percent of the LEL and no toxic gas level were observed, and the radiation level was 0.04 mrad/h. The 24-inch access door through the TAPS was opened, and ventilation into the experiment drift was established.

The team returned to the DPP and began work to open the 36-inch manway door at 1022 hours. At 1050 hours, the door was opened. Suction from the ventilation line at the TAPS provided positive air flow to the zero point side of the DPP, and only background LEL, toxic gas, and radiation levels were noted on the zero point side of the plug. Some removable contamination was

noted inside the DPP crawl space. (A swipe taken showed a removable contamination radiation level of 0.07 mrad/h.) The team had moved to the zero point side of the DPP by 1100 hours. Considerable structural damage was noted.

The team continued into the U12e.20 auxiliary drift where more damage was observed, and a survey showed a radiation level of 0.15 mrad/h. The team turned back towards the U12e.18 drift. At the end of stemming in the U12e.18 bypass drift (see Figure 5.3), a radiation level of 4 mrad/h was observed. Anticontamination clothing of team members was surveyed as they passed back through the DPP at 1128 hours. Because some of the readings from the personnel surveys were above background, the team members removed their anticontamination clothing and left it at the DPP. The team returned to the tunnel portal. No experiments were recovered until 3 May 1978.

5.4.2 Postevent Rehabilitation and Recovery.

No reentry mining was performed for this event, but miners cleaned and rehabilitated the OBP and U12e.18 drifts from 30 November through 6 December 1977. Because no removable contamination was found in the area, no anticontamination clothing requirement was instituted. A Radsafe station was set up in the U12e.18 LOS drift. On 7 December, removal of the DPP was begun, and by 15 November the bulkhead on the zero point side of the plug had been reached. Miners cutting through this bulkhead were required to wear supplied-air equipment with full-face masks because heat from the cutting torch reacting with the coal tar epoxy used as a boundary gas seal around cables caused a health hazard. The bulkhead was removed on 15 November and miners worked to extend railroad tracks through the DPP. Rehabilitation of the U12e.18 LOS drift continued, but only personnel entering the area on the zero point side of the DPP were required to wear anticontamination clothing. Work continued until 1 January 1978 when the miners were moved from E tunnel to other mining efforts.

The tunnel was reopened on 11 April 1978 when removal of the OBP was begun. The decision had been made that the HYBLA GOLD event would be the last detonation in E tunnel, and efforts to remove and salvage or scrap equipment and structures had commenced. On 25 April, operations at the OBP were nearly completed and a survey of the 20 main/20 auxiliary junction area was made. The highest radiation level observed was at an existing drill hole in that area, DNRE #2, drilled during DINING CAR operations. The contact radiation level at this drill hole was 15 mrad/h; water leaking from the hole was at about 2 mrad/h. The radiation levels in the work areas ranged from background to 0.1 mrad/h. Recovery of salvageable materials and scrap continued in the 20 drift areas. No items with removable contamination were allowed to leave the tunnel.

On 2 May 1978, miners began to work in full anticontamination clothing including coveralls, totes, gloves, and supplied-air masks to bore into and sample water from the DNRE #2 drill hole casing, located near the DAC No. 2 crosscut in the 18 drift. Radsafe and industrial hygiene personnel supervised this boring operation. When the miners had completed drilling into the pipe, a maximum radiation level of 100 mrad/h was noted inside the drill pipe, with no indications of toxic gases or any LEL level. Water from the pipe was sampled and drained into barrels in which quick-drying cement was mixed to solidify this contaminated (100 mrad/h) water. On 3 May, an SSS representative removed some experiments from the end of the stemming area. The background radiation level at the 20 drifts junction had increased to 0.5 mrad/h because the barrels containing the solidified contaminated water from DNRE #2 still were in the area. These barrels were removed on 4 May 1978, and the background radiation level fell back to 0.1 mrad/h. Other personnel from agencies participating in the test removed experiments and equipment intermittently until the tunnel was closed in December 1978.

5.4.3 Postevent Drilling.

Seven core holes were drilled in conjunction with the HYBLA GOLD event in the U12e.18 bypass drift between the DAC No. 1 crosscut and the end of stemming. (See Figure 5.3 for drilling locations referred to below.) Upon completion of each of these holes, various surveys and tests were performed to determine the radiation and temperature levels inside the hole, the shape of the hole, and/or tests to judge the integrity of the ground into which the hole had been drilled. All of the personnel involved in these tests and surveys (which included REECo, USGS, Birdwell, H&N, and F&S personnel) were required to wear anticontamination clothing and conform with safety procedures as directed by the responsible health and safety personnel at the location.

On 4 May, a drill rig was set up at 1,407 feet into the U12e.18 bypass drift to drill DNRE #4, which was to run parallel to DNRE #2. Preparations continued until 11 May when drilling actually began. The work area radiation level on the drilling platform was background, although radiation levels as high as 1 mrad/h were observed in the surrounding area. These above-background levels were attributed to the proximity of DNRE #4 to DNRE #2. No radiation was detected on core from DNRE #4 until 19 May when the hole was at a drilling depth of 164 feet. Because the drillers already were wearing anticontamination clothing, no new restrictions were imposed. The maximum radiation level noted on this core was greater than 200 mrad/h, measured on a segment of core from 181 feet into the hole on 19 May. The total drilling depth of 242 feet was reached on 22 May.

On 24 May, set up began for drilling of DNRE #3 at 1,338 feet into the U12e.18 bypass drift. A new "hot line" was set up on the portal side of DAC No. 1, and drilling operations commenced 31 May. The work area radiation level on the drilling platform was 0.06 mrad/h, and, because there was no removable contamination in the area, the drillers no longer were required to wear anticontamination coveralls, only miner's boots or totes.

The total drilling depth of 334 feet was reached on 15 June 1978, with no above-background radiation levels encountered.

USGS personnel began a ground integrity test in the DNRE #3 drill hole on 27 June. This was completed 28 June, and the same test on DNRE #4 was begun. Because positive radiation readings were observed on water from this hole, personnel involved in this operation were required to wear coveralls, gloves, and totes. This test was completed in one day.

Drilling of DNRE #5 was begun on 5 July 1978 at 1,346 feet into the U12e.18 bypass drift. The radiation level on the drill platform was background, and no coveralls were required. Total drilling depth was reached on 18 July at 279 feet, with only one above-background reading of 0.08 mR/h noted on core from 253 feet into the hole.

Drill hole DNRE #7 was begun at 1,407 feet into the U12e.18 bypass drift on 28 July. The total drilling depth of 283 feet was reached on 11 August with no above-background radiation levels observed.

Drilling on DNRE #6 was begun on 18 August 1978 at 1,412 feet into the U12e.18 bypass drift, where the radiation level was 0.09 mrad/h. Gloves were made an anticontamination clothing requirement. By 24 August, full anticontamination clothing was required because radiation was expected to be encountered at that point in the drilling effort; however, no radiation was seen until 25 August when a drilling depth of 158 feet had been reached. The core from this depth read 0.2 mR/h (5 mrad/h), and the work area radiation level increased to 0.3 mrad/h. Very little core was retrieved after this point, but a piece of cement was recovered from about 195 feet into the hole with a radiation level of around 200 mrad/h (30 mR/h). Water from the drilling operations was measured at 0.11 mrad/h, so it was pumped into a tank car and taken outside the tunnel. The radiation level in the area had increased to 1.5 mrad/h (1 mR/h), and anticontamination clothing requirements continued. Drilling ceased at a total drilling depth of 211 feet on 28 August.

Work on drill hole DNRE #8 commenced on 1 September 1978 at 1,406 feet into the U12e.18 bypass drift. Because contaminated water existed in the area inside the radex areas established during previous drilling operations, the radiation level was 1 mrad/h around the drilling equipment.

On 5 September, the drilling crew returned from the weekend to the DNRE #8 work area to find the Radsafe station and the lunchroom filled with water that had come from a fracture in the lower right rib at 1,400 feet into the U12e.18 bypass drift. The water was not contaminated, and wearing anticontamination totes posed a safety hazard because the bottoms of the totes were extremely slick when wet. So plywood was placed on the invert from the zero point side of the "hot line" to the drill rig in the U12e.18 bypass drift to enable the drillers to wear only their miner's boots without becoming contaminated from any radioactive material on the invert. This also brought the general area radiation level down to 0.5 mrad/h. Drilling continued.

On 6 September, grout was pulled from DNRE #8 with a radiation level of 5 mrad/h. Full anticontamination clothing once again was required. No other positive radiation readings were encountered until 232 feet into the hole. A maximum radiation level of greater than 200 mrad/h (60 mR/h) was measured on core from about 235 feet into the hole on 14 September. This core was placed in a side alcove so that the work area background radiation level would stay at as low as possible.

By 15 September, water from the fracture in the lower right rib of the U12e.18 bypass drift began to flow at a rate of 25 gallons per minute. A pump was set up to drain this water, and samples were taken to verify that no radioactive contaminants were present in it. Drilling was stopped at various times during the next few days because water was building up in the area. Positive radiation readings on core continued, and by 20 September, the exposure rate in the area had increased to 1 mR/h (3 mrad/h). Because of the flooding, the drillers' lunchroom had

become contaminated, so they ate their lunch at the Radsafe station. The "hot line" was moved outside the lunchroom area (from 1,350 feet into the drift to 1,300 feet into the drift). By 21 September, enough water pumps had been added to drain the water so that the lunchroom was dry and could be decontaminated. When this decontamination was completed and the area surveyed, the "hot line" was again moved zero point side of the drillers' lunchroom. DNRE #8 was completed on 21 September at a drilling depth of 303 feet. Intermittent flooding continued to be a problem in the lunchroom area.

On 25 September, a complete survey of the U12e.18 drift was made, and contamination was found from the end of stemming to about 1,180 feet into the drift. The Radsafe station and the "hot line" were relocated at crosscut No. 3 (about 800 feet into the U12e.18 drift).

DNRE #9 was begun on 2 October 1978 on the right rib of the U12e.18 bypass drift at 1,404 feet into the drift. Previous drilling had brought the background radiation level up to 1.5 mrad/h, and full anticontamination clothing was required. Above-background radiation levels of 0.2 mrad/h were observed first on core from 113 feet into the hole. Past a drilling depth of about 280 feet, very little core was retrieved. The cuttings (bits of material returned in the drill water) were monitored to determine the radiation level of each foot of newly drilled hole. On 20 October at 353 feet into the hole, efforts to core were abandoned and the drillers were instructed to try to drill to 410 feet. On 23 October, cuttings from 390 feet into the hole showed a radiation level of 1 mrad/h, the highest radiation level noted from this operation. Drilling to 410 feet was completed that day. An additional 10 feet were drilled on 25 October to retrieve core at the request of DNA. Flooding was still a problem, but some of the water flow was stemmed when the DNRE #9 drill hole was capped on 30 October.

No further drilling was accomplished in the E tunnel complex. Various drill hole surveys and tests (including a HYBLA GOLD cavity pressure test) were performed from 1 November until

22 November when work began to grout in all the U12e.18 bypass drift DNRE drill holes. Movement of drilling and associated equipment out of the tunnel had already begun; each piece of equipment coming out of the contaminated area was checked to see if decontamination of the item was necessary before the equipment was moved to a different tunnel. Contaminated equipment was sent to the Area 6 Decontamination Facility. The grouting of all the 18 bypass drill holes was completed on 29 November. On 4 December 1978, all desired equipment had been removed and the tunnel was closed.

5.4.4 Industrial Safety.

Checks for the presence of toxic gases and surveys to measure radiation and LEL levels were made on each shift. The results were then recorded in the monitors' logbook.

Appropriate safety measures were taken to protect mining personnel and prevent unsafe conditions. Industrial safety codes including specific codes for mining, tunneling, and drilling, were established by REECO and emphasized during all operations. A written standard operating procedure was required for each operation involving explosives, toxic materials, radioactive material, or any other operation with the potential for personal injury. Each individual involved in such an operation was required to know the contents of the applicable procedures.

The portal construction area and the tunnel were mandatory hard hat and foot protection areas (safety shoes, safety boots, DOE-issued miner's boots, or toe guards). All personnel on the initial tunnel reentry teams were certified in the use of the Draeger self-contained breathing apparatus and had used the McCaa two-hour breathing apparatus. Standard safety rules and regulations, as spelled out in the "U.S. Bureau of Mines Manual," were observed.

All explosives, electro-explosive components, solid propellants, toxic materials, and radioactive materials were handled,

stored, and transported in accordance with applicable sections of the following documents:

1. Army Materiel Command Regulations (AMCR 385-224).
2. AEC Manual 0500 Series for the Nevada Test Site.
3. Individual Safe Operating Procedures (by experimenter organization).
4. FCTD HYBLA GOLD Safety Instructions.

All personnel engaged in handling, storing, assembling, or installing explosives, propellants, or electro-explosive devices (or observers of those operations) were required to wear safety glasses or other eye protection which had been approved by the DOD Safety Coordinator.

5.5 RESULTS AND CONCLUSIONS.

Telemetry measurements began at 1006 hours on 1 November 1977. All stations were secured by 1300 hours on 15 November. No radioactivity was detected outside the DPP by telemetry units.

Initial radiation surveys of the Mesa and portal areas began at 1113 hours on 1 November and were completed by 1205 hours. No radiation above background was detected at the Mesa trailer park area or at the tunnel complex portal.

Tunnel reentry was divided into three stages; the tunnel was reentered to the gas seal plug on 3 November, reentry past the DPP was made on 14 November, and team members reentered the U12e.20 main and auxiliary drift areas through the DPP in the U12e.18 bypass drift on 29 November. The maximum radiation level during reentry operations was 4 mrad/h, detected at the end of stemming in the U12e.18 bypass drift on 29 November. The maximum toxic gas concentration was 2,000 ppm of carbon dioxide, measured through the gas seal plug on 3 November 1977. Three percent of the LEL was measured during the reentry.

No reentry mining was conducted for the HYBLA GOLD event.

No sampling to recover core samples was conducted on the Mesa. Underground core sampling operations were conducted between 11 May and 25 October 1978, during which time seven core sampling holes were drilled for the HYBLA GOLD event. A summary of these coring operations is as follows:

<u>DNRE Hole Number</u>	<u>Date Hole Started</u>	<u>Distance In Feet Into 18 Bypass Drift</u>	<u>Highest Reading On Core (mrad/h)</u>	<u>Drilling Depth In Feet Of Highest Reading</u>	<u>Average Radiation Level During Drilling (mrad/h)</u>	<u>Date Hole Completed</u>
3	05/31/78	1,338	0.05	-	0.06	06/15/78
4	05/11/78	1,407	> 200	181	0.05	05/22/78
5	07/05/78	1,346	0.08	253	0.05	07/18/78
6	08/18/78	1,412	200	195	1.5	08/28/78
7	07/28/78	1,407	0.05	-	0.05	08/11/78
8	09/01/78	1,406	200	235	1.5	09/21/78
9	10/02/78	1,404	1	390	1.5	10/25/78

Personnel exposure data from self-reading pocket dosimeters were documented on Area Access Registers during individual entries to HYBLA GOLD radex areas from 1 November 1977 to 24 May 1978, when the use of Area Access Registers was discontinued. A total of 135 entries into radex areas was recorded, 8 of which were made by DOD-affiliated participants. No indication of radiation exposure was noted on any self-reading pocket dosimeter nor on film badges worn by reentry and recovery personnel. The minimum detectable gamma exposure with the NTS film dosimeter was 30 mR.

SECTION 6

DIABLO HAWK EVENT

6.1 EVENT SUMMARY.

DIABLO HAWK was a DOD-sponsored test conducted at 0815 hours Pacific Daylight Time (PDT) on 13 September 1978 with a yield of less than 20 kilotons. This test was the eighth in the Hussar Sword series and was the second test in a two-for-one plan to reuse test facilities. The device was detonated in the U12n.10a drift of the N tunnel complex (Figure 6.1) at a vertical depth of 1,273 feet. The purpose of the event was to test the response of materials and equipment to a nuclear detonation environment, test ground shock response of various structures (container types), and conduct x-ray experiments. An evacuated horizontal LOS pipe 1,300 feet long was used to house experiments. DOD and supporting organizations fielded 36 projects for this test.

Stemming was successful and containment was complete. No radioactive effluent from the test was detected onsite or off-site.

6.2 PREEVENT ACTIVITIES.

6.2.1 Responsibilities.

Safe conduct of all DIABLO HAWK project activities in Area 12 was the responsibility of the DOD Test Group Director. Responsibilities of DOE and DOE contractor personnel were in accordance with established DOE-DOD agreements or were the subject of separate action between Field Command/DNA, and the DOE Nevada Operations Office.

Project agencies were responsible for designing, preparing, and installing experiments or delivering them to the installation contractor. After the event, these agencies were responsible for

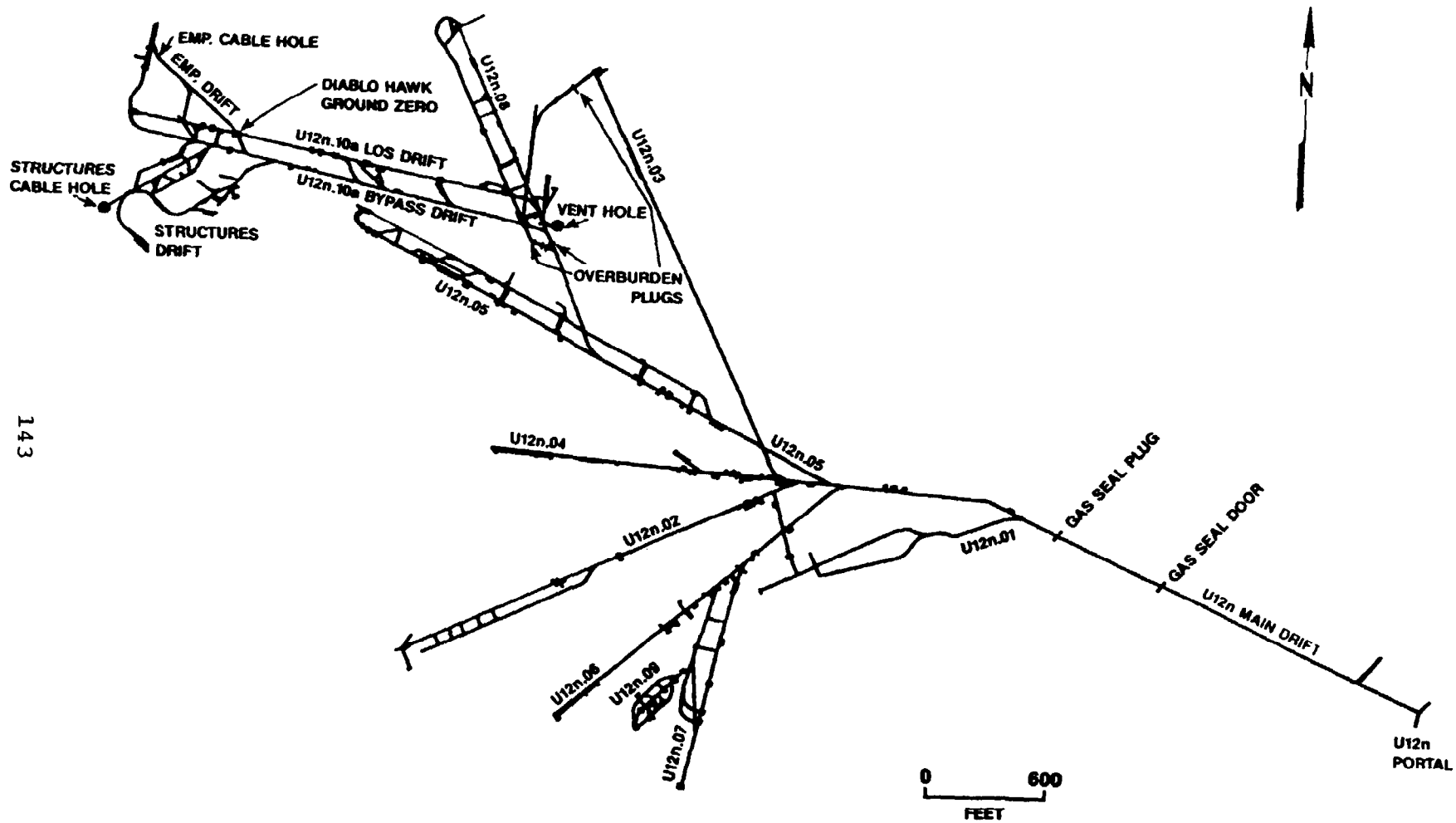

Figure 6.1 DIABLO HAWK event - tunnel layout.

removing samples, analyzing instrument and sample data, and preparing project reports on experiment results.

Device safety and security procedures in the zero point area and the timing and firing control room were in accordance with ERDA Manual Chapter 0560, "Program to Prevent Accidental or Unauthorized Nuclear Explosive Detonations." Because LLL fielded the device, the LLL Test Group Director was responsible for radiological safety within a 6,000-foot radius of the zero point from device emplacement until detonation. After detonation, the DOE Test Controller relieved the LLL Test Group Director of responsibility. When the Test Controller determined that venting had not occurred, he delegated responsibility for radiological safety to the DNA Test Group Director.

6.2.2 Planning and Preparations.

A. Tunnel Facilities Construction.

Following the execution of the MIGHTY EPIC event in May 1976, the U12n.10 tunnel complex was inspected and found in excellent condition for the follow-on event, DIABLO HAWK. The reusable portions of the U12n.10 LOS, bypass, and reentry drifts, and new drifts excavated specifically for the DIABLO HAWK event, were designated as the U12n.10a tunnel complex. Mining of the DIABLO HAWK complex began a few weeks after detonation of the MIGHTY EPIC event.

In August 1976, mining operations in the U12n.10a LOS drift commenced from the MIGHTY EPIC TAPS area. Stemming and the LOS pipe were removed from the MIGHTY EPIC TAPS (the DIABLO HAWK zero point area) to test chamber No. 3. The portion of MIGHTY EPIC LOS pipe from test chamber No. 3 to test chamber No. 1 was repaired, leak tested, and reused in the DIABLO HAWK event.

Mining continued for the structures drifts. The A-B, C-1, C-B, D, D-1, F-1, E, and F drifts were completed by

December 1976. (See Figure 6.2.) A new cable hole to support the structures experiments was drilled to the Mesa and installation of new sections of pipe for the main LOS pipe commenced in December 1976. The G drift was completed in March 1977. Pipe rehabilitation between the stubs area and test chamber No. 3 was completed by April, and installation of new pipe sections was begun. When completed, the DIABLO HAWK LOS pipe included a muffler, DAC, MAC, and TAPS unit; two scatterer systems; several pipe stubs; and three test chambers.

Cable installation was completed in June 1977, and the vertical cable hole for the EMP experiment (drilled from the Mesa to the EMP drift which was mined from the proposed zero point area) was completed in July. The entire EMP drift was mined in August and September. Stemming of the A and B drifts began in October. A new crosscut drift from the bypass drift to the air scatterer alcove was mined in November. Portions of the LOS drift were stemmed and scientific cables were installed in the EMP cable hole in December.

Installation of structural experiments commenced in December 1977. These experiments included: a capsule and water tank as designed by Boeing, SRI jointed models, and an Agbabian Association (AA) water tank, among others. (See Figure 6.3.) By May 1978, installation of the structural experiments and the EMP experiment was completed and scheduled electrical dry runs were begun. A total of three vertical cable holes provided transmission paths for data from the tunnel to the Mesa trailer park. In addition to the Mesa facilities, ROSES units were moved into the U12n.11 and U12n.10a bypass drifts, also for data recording. Test chamber experiment installation began in June. A vacuum test of the entire DIABLO HAWK LOS pipe system was completed successfully in July 1978.

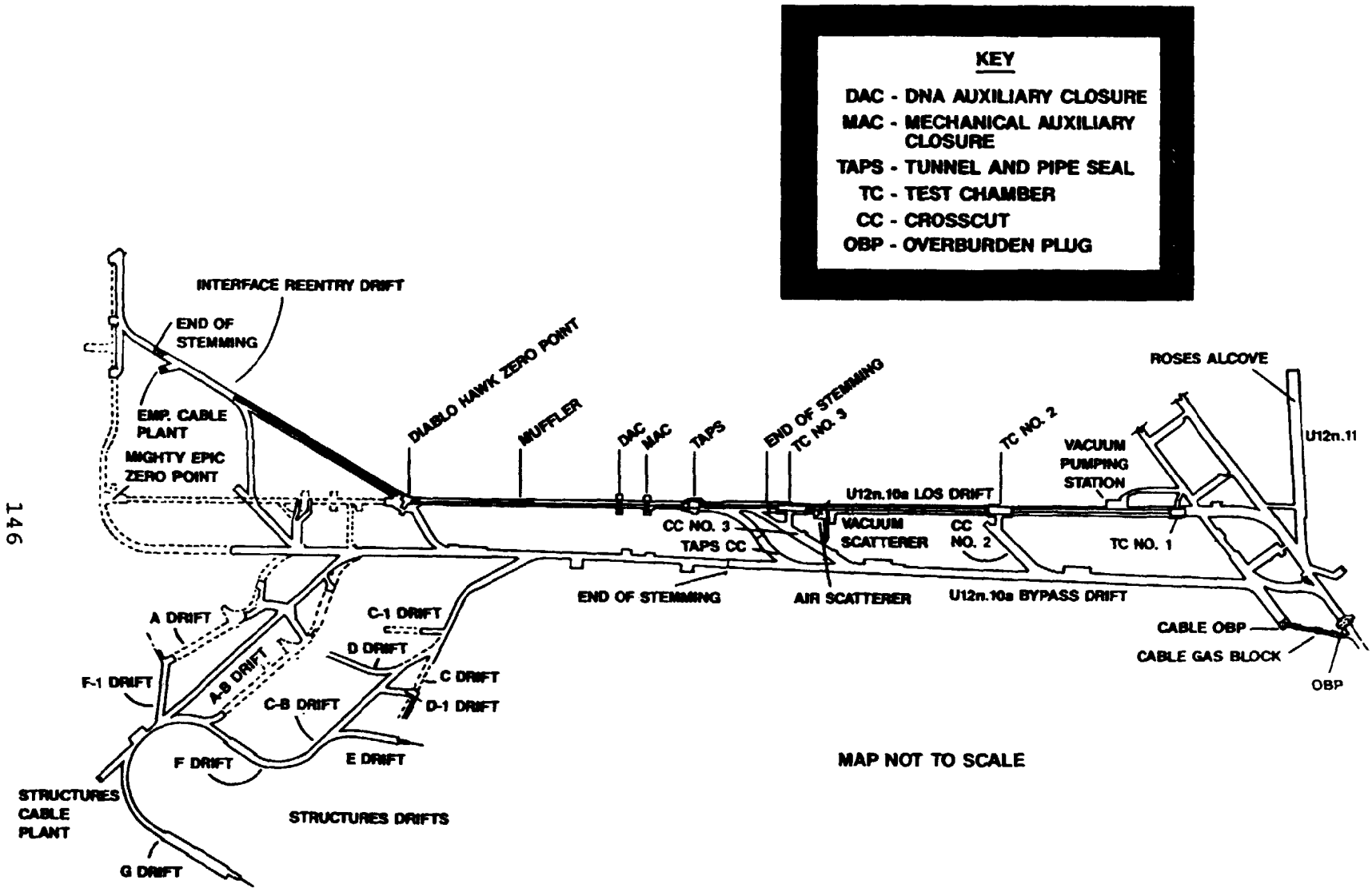
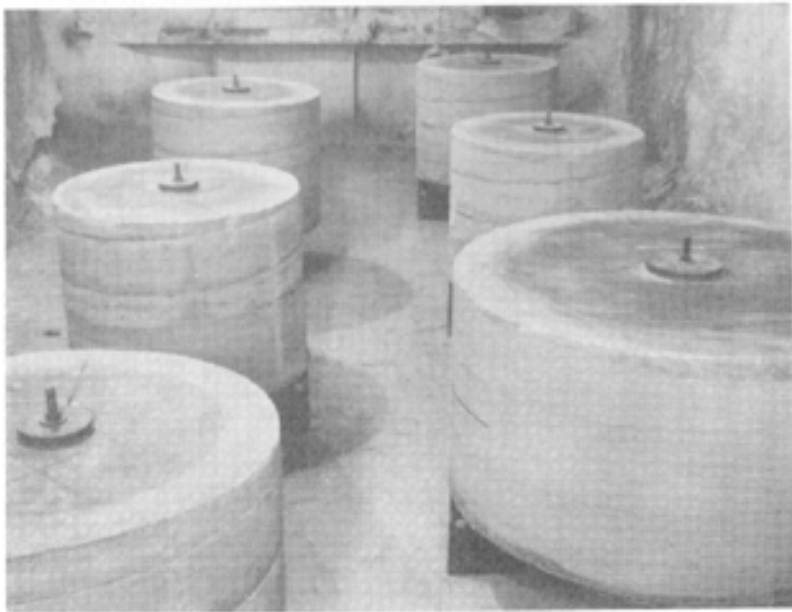
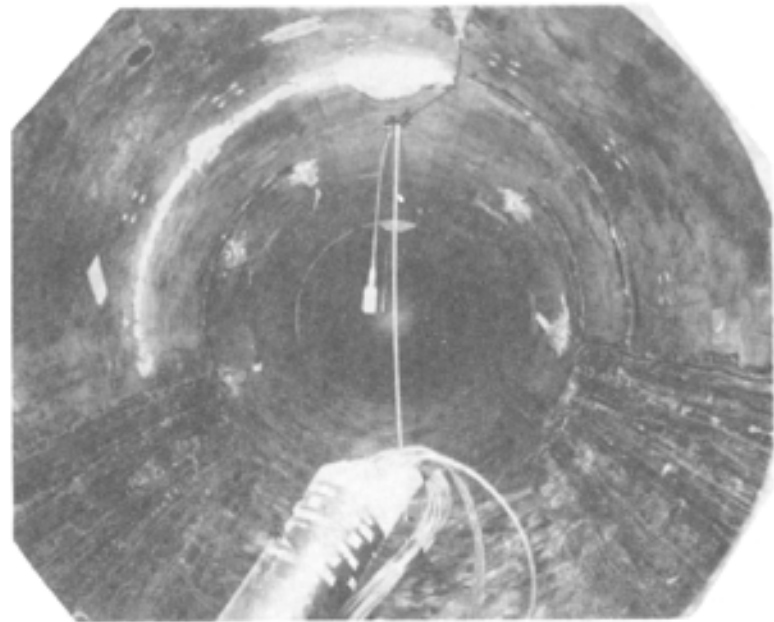

Figure 6.2 DIABLO HAWK event - preevent mining.



SRI jointed models in D-1 drift



Water tank in C-1 drift

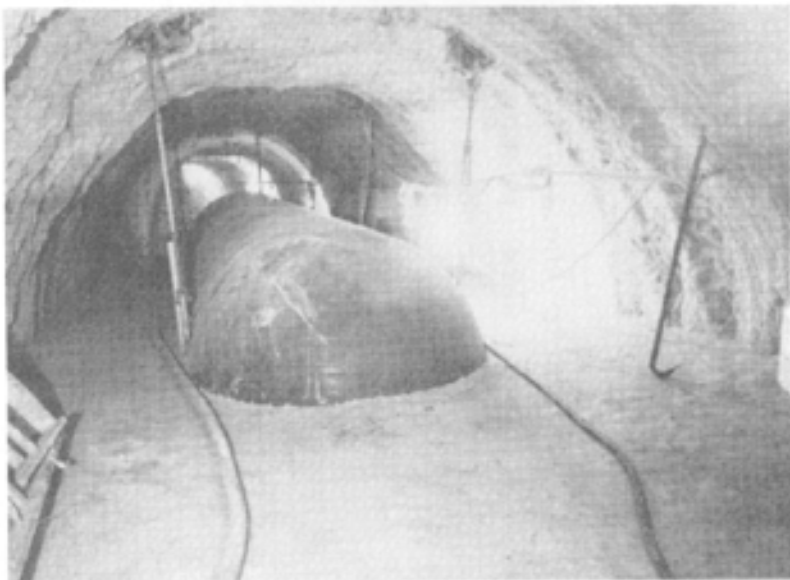

Boeing capsule (foreground) and water tank (background) in A-B drift

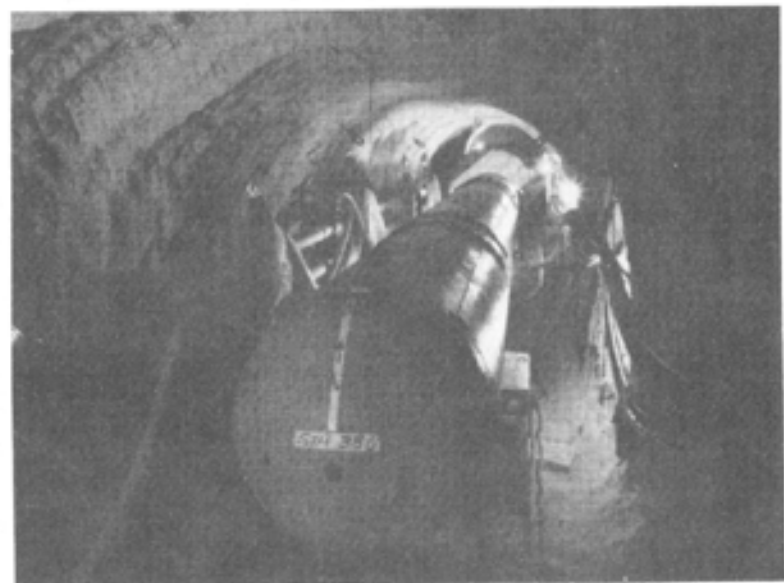

Agabian water tank in E drift after partial stemming pour

Figure 6.3 DIABLO HAWK event - structure experiments.

Containment features consisted of a main overburden plug (OBP) in the U12n.08 drift, a cable gas block OBP in the U12n.08 bypass drift, a thermal shield plug for the ventilation hole off of the U12n.08 drift, and a gas seal plug and door in the main access drift. These were completed in early September 1978.

On 8 August 1978, an MFP dry run was conducted, on 9 August, an FPF dry run was held, the device was installed on 10 August, and an HDR for the device system was completed successfully. Final stemming operations began on 11 August 1978, and an FDR was completed satisfactorily on 12 September 1978. The decision was made to detonate the device on 13 September.

Experimenters for this event included SAI, LMSC, LASL, SLA, AFWL, DNA, Boeing, PI, GE, WES, LLL, and KSC.

B. Radiological Safety Support.

Procedures for radiation exposure and contamination control during this event were in accordance with ERDA Manual Chapter 0524 and requirements of responsible DOD representatives. Radsafe provided monitoring and equipment support.

Prior to the test, detailed radiological safety reentry plans were prepared and issued to participating agencies. Air sampling equipment was positioned in the test area. Radsafe monitors were briefed regarding surface reentry, manned stations, and security station requirements.

Radsafe monitoring teams and supervisory personnel were provided to perform initial radiation surveys, conduct aerial surveys by helicopter, and participate in reentry parties as needed. Radsafe personnel also were standing by at Gate 300 prior to detonation to perform surveys

and provide emergency support as directed; provide and issue anticontamination equipment and material, portable instruments, and dosimeters; operate area control check stations; and perform personnel, equipment, and vehicle decontamination, as required.

Available anticontamination materials and equipment included head covers, coveralls, cloth shoe covers, totes, full-face masks, supplied-air breathing apparatus, plastic suits, plastic bags, gloves, and masking tape.

C. Telemetry and Air Sampling Support.

In addition to permanent RAMS units, 42 temporary units provided surface and underground coverage for DIABLO HAWK as shown in Table 6.1 and Figures 6.4 and 6.5. Also, an air sampling unit was placed at the tunnel portal. All RAMS units and the air sampling unit were installed a minimum of five days prior to scheduled device detonation.

EPA operated 49 air sampling stations and 11 gamma rate recorder stations in the offsite area. Thermoluminescent dosimeters (TLDs) also were placed to verify offsite radiation levels. Twenty-five EPA personnel were fielded for offsite surveillance activities.

D. Security Coverage.

Device security procedures in the zero point area and the timing and firing control room were in accordance with ERDA Manual Chapter 0560, "Program to Prevent Accidental or Unauthorized Nuclear Explosive Detonations." Beginning on D-1, all personnel entering or exiting the controlled area were required to stop at muster or control stations for issue of stay-in badges, or issue and return of muster badges. After area control was established, all through traffic was diverted around the controlled area by use of screening stations.

Table 6.1. DIABLO HAWK event RAMS unit locations
13 September 1978.

<u>SURFACE</u>	
<u>Station</u>	<u>Location</u>
	<u>From the U12n portal:</u>
1	At the portal
2	On the filter system
3	On the vent line
4	On the vent line
5	On the tunnel drain line
6	399 feet N 16° E azimuth
7	275 feet N 89° E azimuth
8	364 feet S 16° E azimuth
9	482 feet S 12° W azimuth
10	558 feet S 48° W azimuth
11	417 feet N 69° W azimuth
12	1,369 feet S 43° E azimuth
	<u>From the cable downhole:</u>
13	At cable downhole
14	177 feet N 43° E azimuth
15	135 feet S 33° E azimuth
16	375 feet S 31° W azimuth
17	78 feet S 89° W azimuth
	<u>From the U12n.10a SGZ:</u>
18	500 feet due north
19	500 feet S 60° E azimuth
20	500 feet S 60° W azimuth
VH	1,585 feet S 76° E azimuth (at the mesa vent hole)
SCH	700 feet S 58° W azimuth (at the structures cable hole)
ICH	699 feet n 44° w azimuth (at the interface cable hole)
ECH	At the Mesa EMP cable hole

Table 6.1. DIABLO HAWK event RAMS unit locations
13 September 1978 (Continued).

UNDERGROUND

Station	Location
	<u>From the U12n.08 drift unless otherwise indicated:</u>
21	880 feet into the U12n.10a LOS drift
22	510 feet into the U12n.10a LOS drift
23	185 feet into the U12n.10a LOS drift
24	500 feet into the U12n.10a bypass drift
25	200 feet into the U12n.10a bypass drift
26	85 feet into the U12n.10a bypass drift
*27ER	85 feet into the U12n.10a bypass drift
28	150 feet into the U12n.11 drift
29	435 feet into the U12n.08 drift from the 05 drift
	<u>From the U12n main drift:</u>
30	1,900 feet into the U12n.05 bypass drift
31	600 feet into the U12n.05 drift
	<u>From the U12n portal unless otherwise indicated:</u>
32	2,600 feet into the U12n main drift
33	2,050 feet into the U12n main drift
*34ER	2,050 feet into the U12n main drift
35	1,700 feet into the U12n main drift
36	1,200 feet into the U12n main drift
37	50 feet into the U12n vent line raise from the U12n main drift
38	200 feet into the U12n main drift

* ER - Extended Range (instrument capable of reading 100 mR/h to
100,000 R/h)

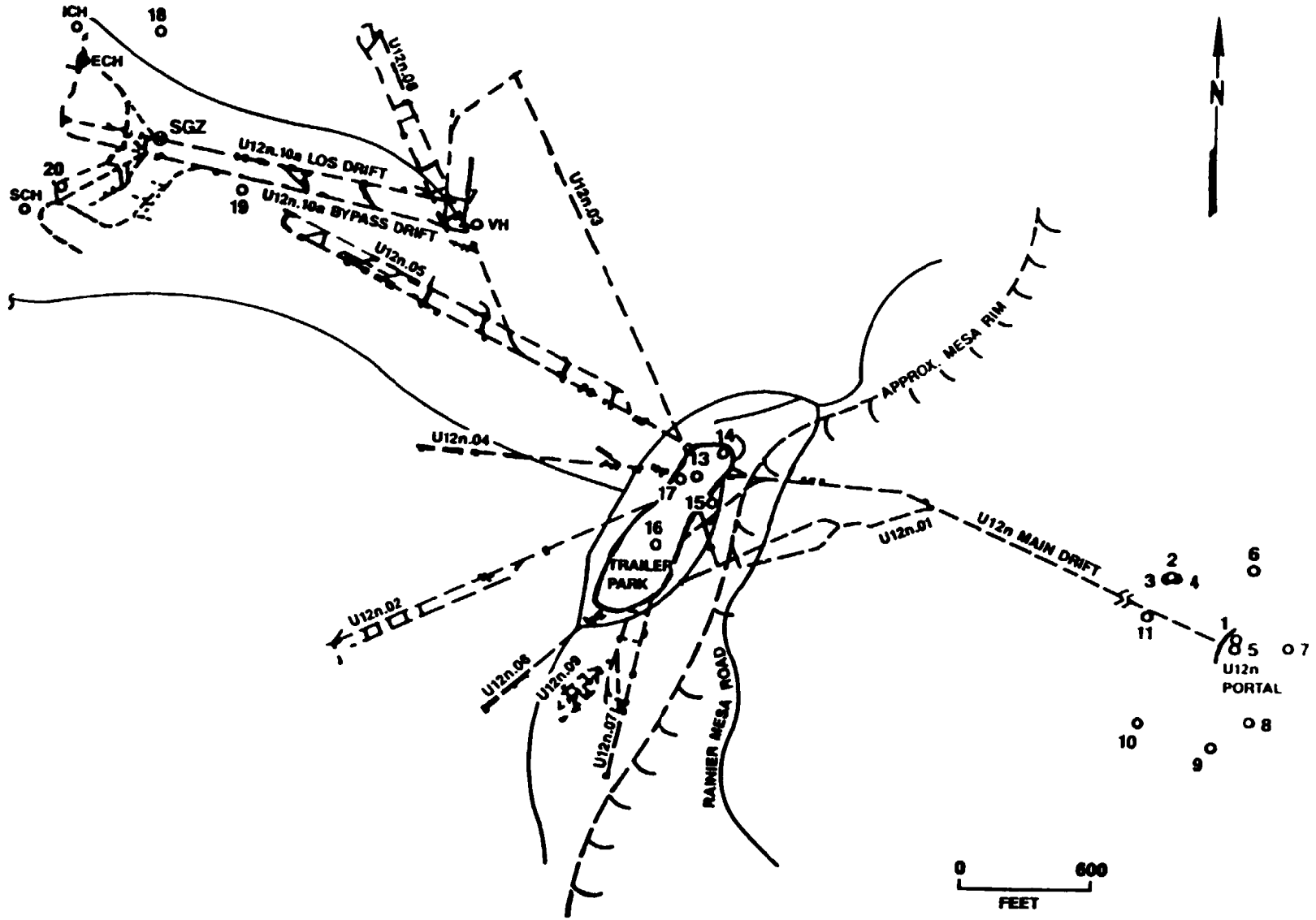

Figure 6.4 DIABLO HAWK event - surface RAMS.

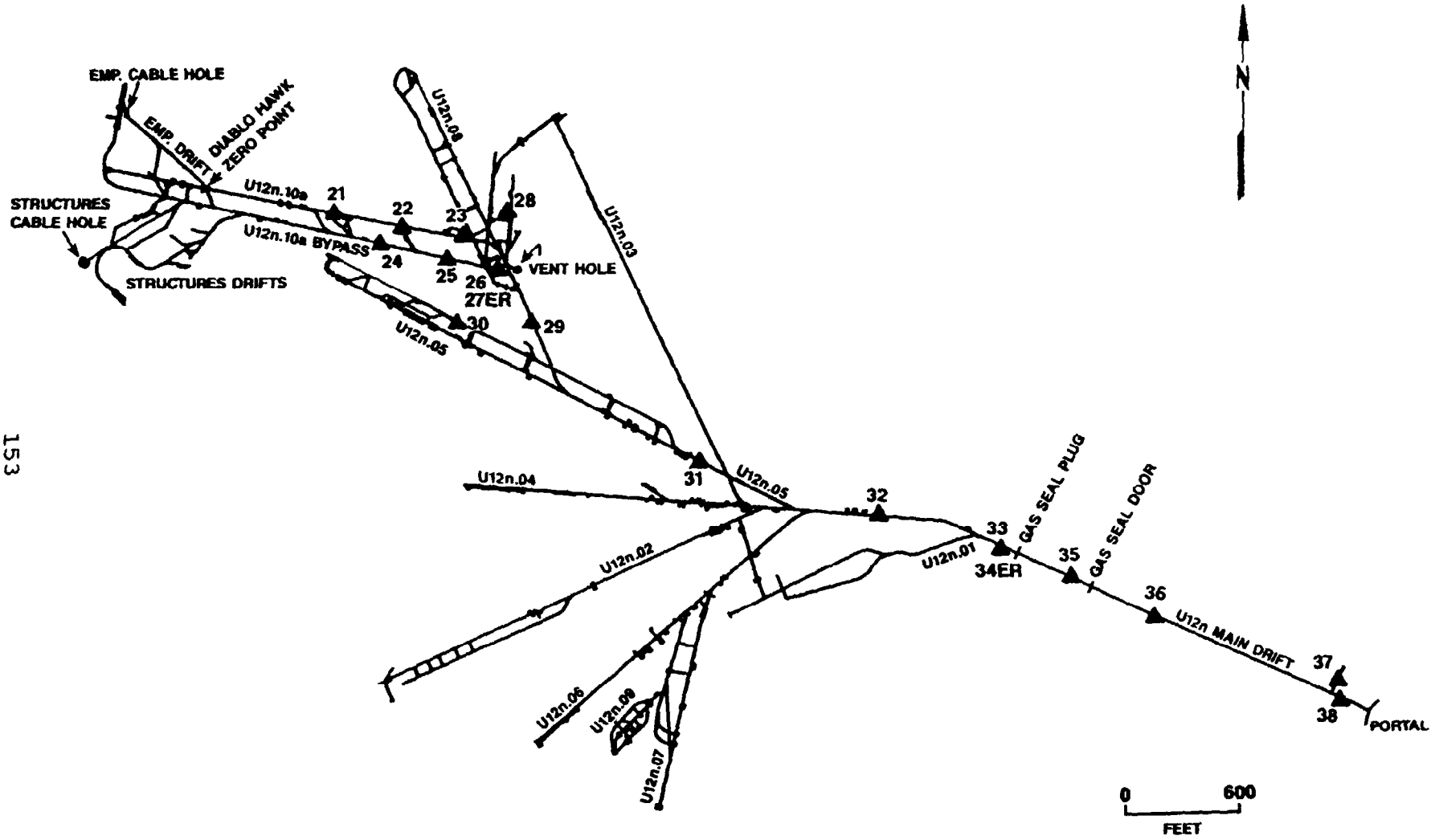

Figure 6.5 DIABLO HAWK event - underground RAMS.

In accordance with the "Test Controller's Operations and Security Plans," contractors and agencies were to have all personnel not connected with this event out of the closed area before the final security sweep began.

E. Air Support.

Three UH1N helicopters and crews were provided by the USAF for cloud tracking and the Test Controller's use, if needed. In addition, the USAF provided a C-130 and crew on standby status for cloud tracking. The EPA provided a Turbo Beech and crew for cloud sampling. Another EPA aircraft was standing by in Las Vegas to undertake tracking duties, if required.

6.3 EVENT-DAY ACTIVITIES.

6.3.1 Preshot Activities.

On 13 September at 0001 hours, all persons except the arming party, tunnel button-up party, microwave timing party, and security guards had exited the tunnel and were clear of the muster area. Permission was granted to arm the device, the device was armed and button-up was completed.

A readiness briefing was held at 0530 hours on 13 September in anticipation of planned test execution that day. Conditions for the test were favorable, and all personnel were mustered out of the area. The countdown started as planned at 0755 hours and continued without difficulty through execution.

The DIABLO HAWK device was detonated at 0815 hours PDT on 13 September 1978.

6.3.2 Test Area Monitoring.

Telemetry measurements began at 0816 hours on 13 September 1978. All RAMS units except for Station Nos. 21, 22, and 23 read background until secured. The RAMS units reflecting positive

radiation levels were located along the LOS pipe and were responding to neutron activation of the LOS pipe and experiments. At H+1 minute, the readings at RAMS unit Nos. 21, 22, and 23 were greater than 1,000 R/h, 400 R/h, and 600 R/h, respectively. Normal decay of this activation radiation was observed. No indications of radioactive effluent were detected by any tunnel, surface, or airborne radiation monitoring units.

Rain in the portal area and on the mesa caused spurious readings to be obtained on many of the surface RAMS units. From 1900 hours until 2145 hours on 14 September, signals from these detectors were not reliable. Proper functioning of these units resumed after the rain stopped and the field wire began to dry out. All RAMS units were secured at 1500 hours on 15 September 1978, when readings on RAMS unit Nos. 21, 22, and 23 had dropped to 45 mR/h, 36 mR/h, and 58 mR/h, respectively.

6.3.3 Initial Surface Radiation Surveys and Recovery Activities.

Four reentry teams (to survey the main Mesa trailer park; Mesa interface trailer park including the EMP cable hole, vent hole, and structures pads; portal area; and portal area ventilation system) were released from Gate 300 at 0915 hours on the D-day. All surveys were completed by 1031 hours. No radiation levels above background (0.05 mR/h) were detected. Gas samples obtained remotely from the zero point side of the OBP indicated there was no above-zero LEL or toxic gas level in the LOS drift. Some above-background radiation readings were noted on samples taken from inside the LOS pipe, indicating the pipe closure system had not been completely successful in preventing seepage of radioactive gases down the LOS pipe some time after detonation. Ventilation to the gas seal plug was established remotely. Data recovery teams were allowed in the Mesa and portal trailers immediately after surveys of the respective areas had been completed. D-day operations were terminated at 1545 hours.

6.4 POSTEVENT ACTIVITIES.

6.4.1 Tunnel Reentry Activities.

Tunnel reentry operations began on D+1. Remote gas sampling was performed again at the tunnel portal before the reentry teams were allowed to proceed into the tunnel. At 0726 hours on 14 September 1978, a work party including Radsafe and industrial hygiene personnel entered the tunnel and travelled to the gas seal door, which was opened at 0810 hours. Gas and air samples were taken at the gas seal door and from the zero point side of the gas seal plug through the sampling line. All readings were background with no indication of any LEL or toxic gas level observed. Both the 36-inch and 24-inch manways were opened, and the vent line through the gas seal plug was reconnected before the work team returned to the portal.

At 0935 hours, reentry team No.1 and the rescue team entered the tunnel bound for the gas seal plug. The team proceeded through the gas seal plug and on to the OBP. Air sampled from the zero point side of the OBP at 1049 hours showed 0 percent of the LEL, 10 ppm of carbon monoxide, and background radiation levels. The manway door through the OBP was opened at 1129 hours. At 1230 hours, the reentry team, dressed in full anticon-tamination clothing and SCBA, passed through the OBP and performed a damage and hazard survey of the U12n.10a bypass drift to the test chamber No. 3 crosscut. Little structural damage was observed on this walk-through.

The reentry team returned to the test chamber No. 1 crosscut. The radiation reading was 350 mR/h at four feet from the door of test chamber No. 1, and a trace of carbon monoxide was noted. The reading at contact with the test chamber No. 1 door was 800 mR/h. The ventilation exhaust valve on the top of the LOS pipe near test chamber No. 1 was opened. The work area radiation exposure at the flex line attached to the exhaust valve vent hole increased from 10 mR/h to 100 mR/h, and the carbon monoxide level inside the flex line increased from 20 ppm to 300 ppm. At 1240 hours, the door to test chamber No. 1

was opened slightly; the radiation reading at the open door was 800 mR/h, and 1,500 ppm of carbon monoxide and 50 percent of the LEL were observed. The team moved to the crosscut at test chamber No. 2, where all radiation readings were background, and no positive LEL or toxic gas level was observed. The team continued to survey as directed. Background radiation readings were noted in the U12n.10a bypass drift at the ROSES drift and crosscut No. 3 junctions. A survey of the crawl space to test chamber No. 3 showed a radiation level of 0.08 mrad/h, 5 ppm of carbon monoxide, and 0 percent of the LEL. The area background at the scatterer alcove was 110 mR/h (130 mrad/h). The team returned through the OBP at 1510 hours.

At 1530 hours, experimenter personnel were allowed entry into the tunnel to recover some experiments from the crosscut No. 1 stubs area and U12n.11 drift ROSES units. The area background at the stubs was 48 mR/h (50 mrad/h), and the radiation level in the U12n.11 drift at the ROSES units was 0.05 mrad/h. Experimenters were surveyed as they left the tunnel at 1700 hours on 14 September.

At 0855 hours on 15 September, reentry team No. 1 and a work team left the portal to reenter the U12n.10a LOS drift. The reentry team entered the LOS drift at test chamber No. 3 in full anticontamination clothing and SCBA. Inside the test chamber door, readings were 150 mR/h, 35 percent of the LEL, and 300 ppm of carbon monoxide. Also, swipe samples were taken, and some removable contamination was noted. The team was out of the LOS drift at 1110 hours. Both the reentry and work teams returned to the OBP. Reentry team No. 2 left the portal, arriving outside test chamber No. 2 at 1145 hours. Outside the door, 5.5 mR/h, 0 percent of the LEL, and no toxic gas level were measured; inside the door, 100 mR/h, 0 percent of the LEL, and 300 ppm of carbon monoxide were noted. At 1330 hours, all doors to the chambers in the LOS pipe were locked.

SLA experimenters entered the stubs area on 15 September at 1415 hours for experiment recovery. The radiation level in this

area was now 25 mrad/h (20 mR/h, gamma only). Some experiments also were removed from the scatterer alcove area, where the exposure rate was about 55 mR/h. All experimenter personnel had exited the tunnel by 1520 hours.

Mining began on swing shift, 14 September, to remove the gas seal plug, and the plug was removed on 16 September. Work then began to mine through the OBP. The OBP was mined out completely on 18 September and railroad tracks were relaid. Rehabilitation of the U12n.10a bypass and LOS drifts was begun. On 18 September between 1630 and 1830 hours, a walk-through of the area beyond the OBP was conducted by the SLA Health Physicist and support personnel to assess toxic gas, LEL, and radiation hazard areas. Ventilation to the various work areas was checked so that respiratory protection requirements could be determined as necessary. Water was noted on the invert around test chamber No. 3. Later investigation showed this water to be originating from a rock fissure. The water was contaminated with activation products from inside the LOS pipe, and radiological safety requirements were adjusted as this water continued to be of concern during reentry, recovery, and mining operations, as discussed below.

On the morning of 19 September, a pipe evaluation team entered the LOS pipe at test chamber No. 3. Inside the test chamber, the general radiation level was 5 mrad/h, with a maximum radiation level of 12 mrad/h noted in the area. About 40 feet on the portal side of the TAPS, an eight-inch tear was noted at the top of the LOS pipe. A carbon monoxide level of 10,000 ppm and 100 percent of the LEL were noted at the tear. The pipe evaluation team completed its survey, after which experiment removal and other routine postevent work began in earnest. Ventilation was established at the tear and near the TAPS in the LOS pipe to lower carbon monoxide and LEL levels. Experimenters were surveyed as they left their respective recovery areas, and anticontamination and respiratory protection requirements were imposed as necessary for each work area. A "hot line" was set up in the U12n.10a bypass drift zero point side of the U12n.10a bypass/U12n.08 bypass junction on 20 September.

The tear in the LOS pipe again was surveyed on 25 September. The carbon monoxide level had dropped to 2,700 ppm, but the LEL remained at 100 percent. This tear continued to be monitored whenever personnel were required to work in the area. All experiments were removed by 28 September 1978. Some equipment recovery was performed after this date by experimenter personnel; anticontamination and respiratory protection requirements were established for each area as conditions required.

On 29 September, a pump was set up to reduce the buildup of water around test chamber No. 3. On 3 October, efforts were begun to open the TAPS door. A survey of the tear in the LOS pipe showed 100 percent of the LEL, 1,600 ppm of carbon monoxide, and a 0.04 mrad/h radiation level. Around the TAPS door, no LEL or carbon monoxide level was indicated, and the radiation level was 0.05 mrad/h. A supplied-air system was set up before opening of the TAPS was attempted. At 1515 hours, personnel wearing full-face masks with supplied air opened the TAPS door; 100 ppm of carbon monoxide, 10 percent of the LEL, and a 0.05 mrad/h radiation level were observed inside the door.

On 4 October, a survey on the zero point side of the TAPS door showed no LEL level or toxic gas and a radiation level of 0.6 mrad/h. At 1300 hours that day, personnel using supplied-air equipment with full-face masks entered the LOS pipe area on the zero point side of the TAPS and proceeded toward the MAC. Readings at the MAC were 100 ppm of carbon monoxide, 10 percent of the LEL, and 0.5 mrad/h. A small hole was noted on the left side of the MAC. Levels of 12,000 ppm of carbon monoxide, 100 percent of the LEL, and 110 mrad/h (10 mR/h) were detected coming from this hole. A flex line was hooked up in the area of the hole to provide ventilation to the area. All personnel had exited the pipe by 1520 hours.

Reentry activities continued. Personnel passed through the MAC and on to the DAC. A series of holes were drilled through the DAC, and levels as high as 12,000 ppm of carbon monoxide, greater than 100 percent of the LEL, and 0.2 mrad/h were observed

during drilling. These holes were completed 2 November. This completed initial reentry into the U12n.10a complex areas. Surveys and equipment recovery continued for several months in the LOS pipe area after experiment removal; anticontamination clothing and respiratory protection requirements were imposed as necessary.

6.4.2 Postevent Mining.

Cleanup and rehabilitation began on 22 September 1978 in the U12n.10a bypass drift near crosscut No. 3 to prepare for reentry mining. Extensive reentry drifts were mined to recover experiments and equipment and examine the various structures fielded on the DIABLO HAWK event. (See Figure 6.6.) Mining was "as directed," and often one area was abandoned temporarily as another reentry/recovery project was made a priority. A summary of these drifts, including start and stop dates and the radiation encountered, appears in Table 6.2. No general radiation protection clothing requirement was put into effect because there was no uncontrolled access to areas with above-background radiation levels. A discussion of special health and safety situations and protection requirements follows. No alpha contamination was noted on any of the mined out structures.

After experimenters had departed 28 September, mining of the DIABLO HAWK structures reentry drift was begun at 806 feet into the U12n.10a bypass drift. All muck readings were background. On 9 November, at 666 feet into the structures reentry drift, the C structures drift was reached. Mining continued, and a 0.5 mrad/h radiation level was noted at the end of the C structure chamber. At 1140 hours, a hole was drilled through the C structure steel door plate to check the air quality. Inside the hole, the radiation level was 0.06 mrad/h, and 1,000 ppm of carbon monoxide and 10 percent of the LEL were measured. Mining continued on the structures reentry drift.

On 7 November, a pump was set up to reduce water in the test chamber No. 3/crosscut No. 3 area. The radiation level at contact with this water had increased to 1 mrad/h; a maximum radia-

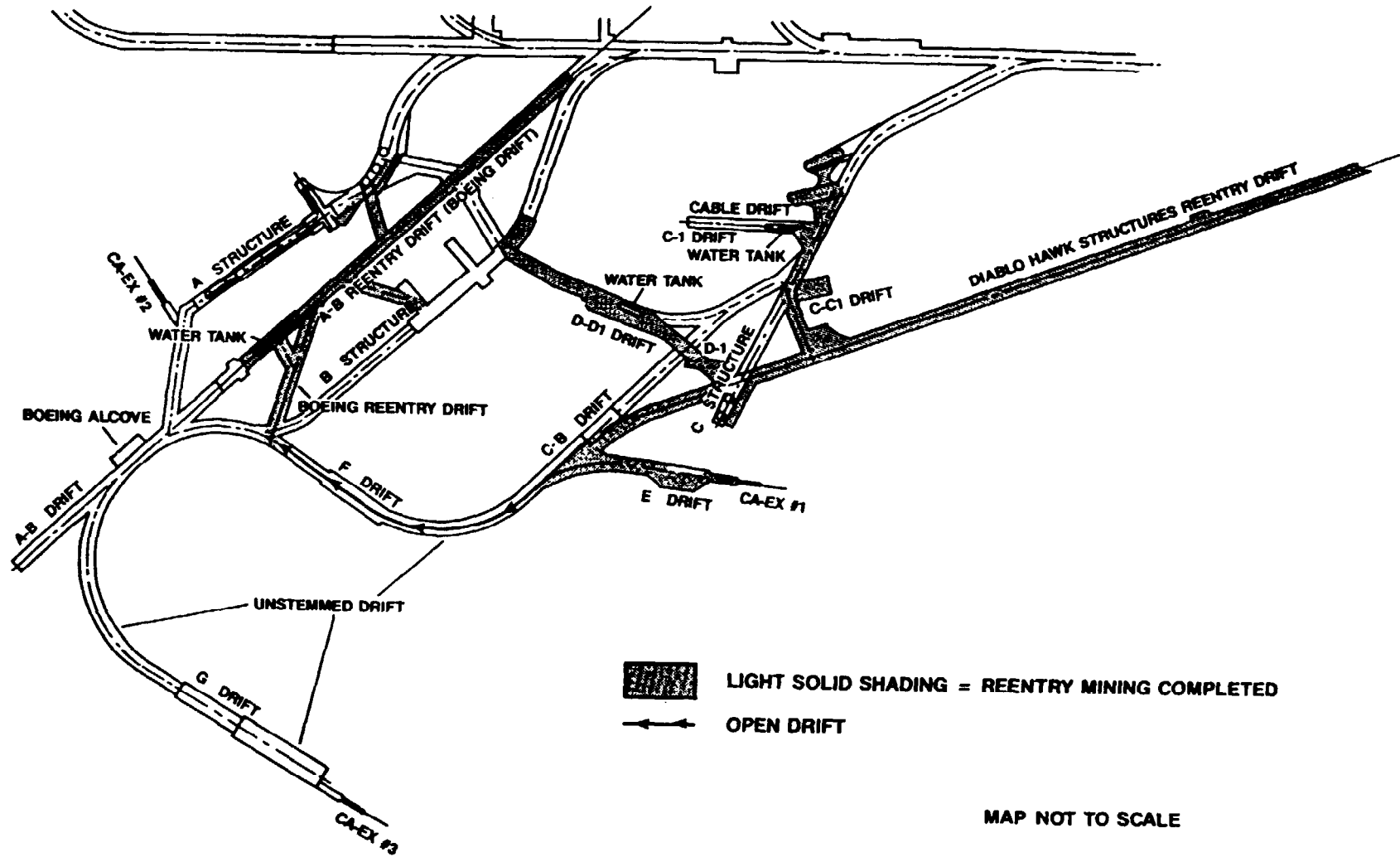

Figure 6.6 DIABLO HAWK event - reentry mining.

Table 6.2. DIABLO HAWK reentry drift radiation summary.

<u>Reentry Drift (RD)</u>	<u>Start Date</u>	<u>Finish Date</u>	<u>Maximum Area Radiation Level (mrad/h unless otherwise stated)</u>	<u>Maximum Recorded Radiation Level (mrad/h unless otherwise stated)</u>	<u>Location of the Highest Above-Background Radiation Level</u>
Structures RD	10/28/78	12/07/78	0.05	0.06	Inside C Structure
TAPS RD	12/06/78	01/10/79	0.05	0.05	
Boeing RD	01/10/79	01/26/79	0.05	0.05	
Boeing Crosscut	01/24/79	01/25/79	0.05	0.05	
M&D RD	02/05/79	03/12/79	0.5 mR/h	2	At hole in the LOS pipe, on the portal side of the DAC
A-B RD	01/25/79	10/05/79	0.05	0.05	
CA-EX #1 RD	02/20/79	03/08/79	0.05	0.05	
CA-EX #2 RD	02/15/79	02/20/79	0.05	0.05	
C-C1 RD	03/05/79	05/03/79	2 mR/h	200 (50 mR/h)	At 1+03 in C-C1 RD
D-D1 RE	03/12/79	08/27/79	0.05	0.05	
A Crosscut	04/17/79	10/02/79	0.05	0.05	
B Crosscut	04/17/79	09/11/79	0.05	0.05	

tion level of 2 mrad/h was noted in the area. Ground water was seeping through cracks in the LOS pipe, picking up activated materials, and passing back out into the drift, increasing the work area radiation level. On 9 November, a pump with a drain line was set up to remove water from inside the LOS pipe. The drain line was removed inadvertently and contaminated water again began to build up in the crosscut. The area was roped off as a contaminated area and the pump reinstalled with "Contaminated Material" tape on the drain line. Pumps were used from this time on during operations in the area.

On 13 November, a swipe sample from the inside of the C structure showed removable contamination. Periodic checks of the C structure were made, and on 20 November, 2,000 ppm of carbon monoxide, 70 percent of the LEL, and a background reading of 0.04 mrad/h were measured in the chamber. A vent line was hooked up to the chamber, and on 21 November the air inside C structure had returned to normal levels.

Beginning in December, sections of LOS pipe were removed by the pipefitters. As each section of pipe was removed, swipe samples were taken to determine the level of removable contamination, and radiation protection requirements were adjusted as necessary to control any potential hazard.

On 8 January 1979, Boeing personnel opened an experiment box located in the Boeing alcove located in the A-B drift, and a pungent odor was observed. The box was reclosed until the next day when industrial hygiene, Radsafe, and mining personnel, dressed in full anti-contamination clothing and SCBA, reopened the box. Samples were taken, but no indication of any toxic gas, LEL, or above-background radiation level was observed. After laboratory analysis of the samples was completed, personnel again were allowed to resume work on the box.

On 12 January, a probe hole, designed to break through into the water tank structure area in the A-B drift, was started at about 40 feet into the Boeing reentry drift. Supplied-air equipment was made a requirement as drilling approached the break-

through point. At 1345 hours on 15 January, the miners drilled into the sand surrounding the water tank. Aside from a foul odor, normal air conditions were noted, and no above-background radiation was observed.

On 16 January, LASL personnel worked in crosscut No. 3 dressed in coveralls, totes, and gloves. Area radiation levels still were above background at 0.3 mrad/h. A request was made by the SLA Health Physicist on this date to check tritium levels in standing water outside the TAPS, from water in the area around the LOS pipe and the crosscut No. 3 junction, and from water coming from the Boeing reentry drift probe hole. These samples showed activities of 4.2×10^{-4} $\mu\text{Ci/cc}$, 1.5×10^{-4} $\mu\text{Ci/cc}$, and 3.4×10^{-4} $\mu\text{Ci/cc}$, respectively.

Limited reentry mining was accomplished in the U12n.10a complex during the months of February and March. Radsafe personnel accompanied user and support personnel into the various excavated structures and drifts. In some drifts, vent lines had been removed and air quality was poor; these areas were checked and air flow reestablished as necessary during tours and inspections.

The MAC and DAC (M&D) reentry drift was begun on 5 February. On 15 February, the first of two probe holes drilled toward the DAC from the M&D drift was begun. Although radiation levels still were at background, the heading of the M&D reentry drift was designated as a radex area and anticontamination clothing including coveralls, gloves, and totes or miners boots was made a requirement. On 28 February, the second hole was begun. Industrial hygiene and Radsafe personnel monitored these drilling operations continuously. The radiation level of the tailings rose from background to 0.12 mrad/h on 1 March. The total drilling depths of the two holes were 33 and 43 feet.

On 2 March, mining in the E reentry drift had reached the CA-EX #1 bulkhead. A survey of a crack around the bulkhead indicated a background radiation reading of 0.04 mrad/h radiation level at contact, and no carbon monoxide or any LEL level was

observed. Greater than 100 percent of the LEL and 2,000 ppm of carbon monoxide were found in rockbolt holes and cracks in the left rib. Work began to cut out the bulkhead. Meanwhile, the 43-foot probe hole in the M&D reentry drift was being closed off with a packer plug and cemented. During the sealing, gas concentrations of greater than 6,000 ppm of carbon monoxide and over 100 percent of the LEL were being forced from the end of the packer assembly. (The radiation level was at background.) A vent line had been set up near the end of the packer assembly, so no indication of gases was observed in the drift. A valve allowed gases to be monitored through the plug as desired.

On 5 March, mining on a crosscut to the DAC began at about 160 feet into the M&D reentry drift. Supplied-air equipment was brought in for the miners working on this crosscut, and totes were made mandatory in the M&D area as well as the previously prescribed coveralls and gloves.

On 9 March, a pipe three to four inches in diameter which read 10 mR/h was uncovered at about 70 feet into the C-C1 drift. On 12 March, workers in full anticontamination clothing and supplied-air equipment drilled through this pipe, and water with a radiation level of 0.07 mrad/h spilled out. The quantity of this water was not substantial so it was allowed to drain onto the invert of the radex area.

Muck with a maximum radiation level of 1 mrad/h (0.5 mR/h) was recovered from the DAC crosscut on 12 March. A hole in the LOS pipe was discovered on the portal side of the DAC. Surveys into the pipe through this hole revealed levels of 100 ppm of carbon monoxide, 0 percent of the LEL, and 2 mrad/h. Mining of the M&D drift was completed on 12 March, although experiment recovery continued in the area for the next several days. No removable radioactive contamination was found on these experiments. The maximum exposure level in the LOS pipe, DAC crosscut, and M&D reentry drift work areas was 0.5 mR/h.

On 20 March, the pipe in the C-C1 drift pipe with the above-background radiation level had been removed, and mining con-

tinued. However, on 21 March at 103 feet into the C-C1 drift, the radiation level at the face was surveyed at 5 mrad/h, readings on the excavated rock (muck) had risen from background levels to 0.15 mR/h, and a reading at the top of the face was 50 mR/h (150 mrad/h). A bad smell, 200 ppm of carbon monoxide and 35 percent of the LEL were noted, so operations were shut down in the drift until the next day when the area had ventilated and a survey showed normal air conditions. Activities in the heading were discontinued, although work was performed in other areas in the drift. The area exposure rate was 2 mR/h, and full anticontamination clothing was made a requirement. Mining in the C-C1 drift heading did not resume until 26 April. Readings were taken daily in the C-C1 drift during the non-work periods, and radiation levels as high as 200 mrad/h (50 mR/h) were measured.

Alpine mining at the heading of the C-C1 drift was restarted 26 April. Anticontamination clothing requirements continued from when radiation first had been detected. The area exposure rate had dropped to 0.1 mR/h because clean earth had been spread over the contaminated muck. Mining in the C-C1 drift heading was completed on 3 May at 146 feet into the drift, although mining to evaluate experiments along the ribs continued after this time. No other source of above-background radiation was encountered in this drift.

During the months of May through August 1979, cleanup and removal of equipment and instrumentation by mining and user personnel continued. Air samples were run and surveys taken when work was performed in the reentry drifts, and all equipment removed from the area was checked and decontaminated as necessary to assure it was free from any removable contamination.

On 15 May, a security gate was installed at 487 feet into the main DIABLO HAWK reentry drift. This gate was locked to prevent unauthorized traffic into security and contaminated areas. Personnel authorized to pass through this gate were escorted by Radsafe personnel.

Recovery of cable and equipment began in the C-C1 drift on 31 May. The work area background was 0.2 mrad/h, and radiation protection requirements continued. The radiation level dropped to 0.15 mrad/h and below in some areas as less contaminated rock was mined out. This recovery effort was completed 14 June.

Drillers began to drill short holes into the various chambers of the C structure on 18 July to recover core. Although the C structure drift still was considered a radex area and full anticontamination clothing was required, no above-background radiation levels were noted at contact with the core. This drilling was completed on 1 August.

On 16 August, the water tank in the cable drift off the C-C1 drift was uncovered. The work area radiation level was 0.3 mrad/h, so full anticontamination clothing was worn for this operation. An exposure rate of 6 mR/h (60 mrad/h) was measured at the door of the structure, and 4 mR/h (40 mrad/h) was noted at contact with the stemming around the structure. The contact reading on a water sample taken from the structure was 0.2 mR/h (0.4 mrad/h). This water showed a tritium level of 3.4×10^{-1} μ Ci/cc. On 23 August, DOD gave permission for this radioactive water in the CC-1 water tank to be diluted and drained.

Removal of portions of the LOS pipe at crosscut No. 2 for scrap or burial at the U3ax waste site began on 26 September. (The U3ax waste site was a subsidence crater in Yucca Flat used for radioactive waste disposal). The highest area radiation level during the days worked was 0.12 mrad/h. No removable contamination was noted on the pipe.

A radiation level of 0.09 mrad/h was detected on the safety shoes of those working around test chamber No. 3 on 29 October. The muck from this area was posted with radex area signs, and miners in the area were required to wear totes as well as coveralls when in the area. Pipefitters began to remove the TAPS on 5 November. Three security gates limiting access to the C-B, CC-1, and DD-1 drifts were completed 13 November. On 16 November the

TAPS was removed. Cleanup and final removal of equipment continued until 3 December 1979 when work in the area ceased.

6.4.3 Postevent Drilling.

No drilling to recover zero point core samples was conducted underground or from the Mesa for this event. Holes were drilled to verify direction and ground integrity during reentry mining, but all radiation readings were background during these operations.

6.4.4 Industrial Safety.

Checks for the presence of toxic gases and surveys to measure radiation and LEL levels were made on each shift. The results were then recorded in the monitors' logbook.

Appropriate safety measures were taken to protect mining personnel and prevent unsafe conditions. Industrial safety codes including specific codes for mining, tunneling, and drilling, were established by REECO and emphasized during all operations. A written standard operating procedure was required for each operation involving explosives, toxic materials, radioactive material, or any other operation with the potential for personal injury. Each individual involved in such an operation was required to know the contents of the applicable procedures.

The portal construction area and the tunnel were mandatory hard hat and foot protection areas (safety shoes, safety boots, DOE-issued miners boots, or toe guards). All personnel on the initial tunnel reentry teams were certified in the use of the Draeger self-contained breathing apparatus and had used the McCaa two-hour breathing apparatus. Standard safety rules and regulations, as spelled out in the "U.S. Bureau of Mines Manual," were observed. HEPA canister filters were supplied routinely for hazardous situations in which full-face masks were required. An array of specialized canister filters could be obtained upon request for special hazardous situations.

All explosives, electro-explosive components, solid propellants, toxic materials, and radioactive materials were handled, stored, and transported in accordance with applicable sections of the following documents:

1. Army Materiel Command Regulations (AMCR 385-226).
2. AEC Manual 0500 Series for the Nevada Test Site.
3. Individual Safe Operating Procedures (by experimenter organization).
4. DIABLO HAWK Safety Regulations.

All personnel engaged in handling, storing, assembling, or installing explosives, propellants, or electro-explosive devices (or observers of those operations) were required to wear safety glasses or other eye protection which had been approved by the DOD Safety Coordinator.

6.5 RESULTS AND CONCLUSIONS.

Telemetry measurements began at 0816 hours on 13 September 1978 and all telemetry stations were secured at 1500 hours on 15 September 1978. No radiation other than that from usual activation products was detected by telemetry units.

The initial radiation surveys of the Mesa and portal areas began at 0915 hours on 13 September and were completed by 1031 hours. No radiation above background was detected at the Mesa trailer park area or at the tunnel complex portal.

Reentry into the tunnel began at 0726 hours on 14 September 1978. The maximum radiation reading during reentry operations was 800 mR/h, detected at the test chamber No. 1 door on 14 September. The maximum toxic gas concentration measured was 12,000 ppm of carbon monoxide, measured at a small hole in the MAC on 4 October 1978. This level of carbon monoxide and greater than 100 percent of the LEL (the highest LEL level observed) were noted in samples drawn from the zero point side of the MAC between 4 October and 2 November while a series of holes were being drilled through the MAC.

On 22 September, reentry mining operations began in the U12n.10a bypass drift. These efforts continued until 3 December 1979. Table 6.2 is a summary of the reentry drifts excavated and the radiation encountered. The highest LEL and toxic gas levels observed were found during the sealing of a probe hole in the M&D drift. A survey of the gases from inside the probe hole indicated greater than 100 percent of the LEL and 6,000 ppm of carbon monoxide. The highest radiation level encountered was 200 mrad/h (50 mR/h), noted at the heading of the C-C1 drift when the face was at 103 feet. No alpha radiation was observed on any of the recovered structures or equipment.

There was no drilling from underground or Rainier Mesa to recover zero point core samples for the DIABLO HAWK event.

Personnel exposures received during individual entries to DIABLO HAWK radex areas from 14 September to 22 September 1978 when the use of Area Access Registers was discontinued, are summarized below. Average exposures are from self-reading pocket dosimeters as recorded on Area Access Registers. Maximum exposures are from film dosimeter records.

	<u>No. of Entries Logged</u>	<u>Maximum Exposure (mR)</u>	<u>Average Exposure (mR)</u>
All Participants	347	140	3
DOD Participants	110	0*	4

* The minimum detectable radiation exposure which could be measured by the NTS film badge dosimeter was 30 mR; an exposure of zero means any exposure received was below this level.

SECTION 7

HURON KING EVENT

7.1 EVENT SUMMARY.

HURON KING was an underground nuclear experiment conducted by DOD and LANL at 0810 hours Pacific Daylight Time (PDT) on 24 June 1980 with a yield of less than 20 kilotons. The device was detonated in Area 3 (U3ky) at a depth of 1,050 feet. HURON KING was the first DOD vertical line-of-sight (VLOS) pipe test since the DIAGONAL LINE event (1971, see DNA 6323F of this series of reports). The purpose of the HURON KING event was to test the response of materials and equipment to a nuclear detonation environment. The event involved the use of a vacuum tank, developed to simulate a free space environment, which contained a space satellite (STARSAT). Five projects were fielded by experimenters.

Stemming was successful and containment was complete. No radioactive effluent from the test was detected onsite or off-site.

7.2 PREEVENT ACTIVITIES.

7.2.1 Responsibilities.

In early 1979, DNA and LANL entered into an agreement in which LANL was to provide the device, a drill hole in Area 3, the VLOS pipe system (including closures), timing and firing system control, and related engineering support. DNA agreed to provide the test object, the experiment tank with associated vacuum and recovery systems, radiation and containment measurements, signal cables, recording instrumentation for experiments, and related operational and engineering support. As event sponsor, DNA was responsible for containment. In a separate agreement, SNL accepted responsibility for containment diagnostics and a portion of the radiation measurements.

Safety in the testing area was the responsibility of the DOD Test Group Director or his representative. Responsibilities of DOE and DOE contractor personnel were in accordance with established DOE-DOD agreements or were the subject of separate action between Field Command/DNA, and the DOE Nevada Operations Office.

Project agencies were responsible for designing, preparing, and installing experiments or delivering them to the installation contractor. After the event, these agencies were responsible for removing samples, analyzing instrument and sample data, and preparing project reports on experiment results.

Device safety and security procedures in the zero point area and the timing and firing control room were in accordance with ERDA Manual Chapter 0560, "Program to Prevent Accidental or Unauthorized Nuclear Explosive Detonations." Because LANL fielded the device, the LANL Test Group Director was responsible for radiological safety within a 3,500-foot radius of the zero point from device emplacement until detonation. After detonation, the DOE Test Controller relieved the LANL Test Group Director of responsibility. When the Test Controller determined that venting had not occurred, he delegated responsibility for radiological safety to the DNA Test Group Director.

7.2.2 Planning and Preparations.

A. Area Facilities Construction.

Area 5 had previously been used for DOD VLOS tests, but the geologic characteristics of Area 3 were determined to be superior for containment, so the event was given an Area 3 location and designated U3ky.

The VLOS pipe for this event was 1,050 feet long and consisted of 17 steel pipe sections, flanged together, and several containment-related components. These components would include the device canister (with a bolt catcher to deflect objects dropped down the pipe

during assembly away from the zero point), a muffler (which was designed to reduce the flow of non-radiation energies up the VLOS pipe), the super-high explosive (HE) machine (designed to close off the pipe with high explosives after radiation passage), clamshell shutters (redundant debris control valves), gas shutters (to control movement of gas up the VLOS pipe), the fast gate (which was the final debris barrier), and the slide valve (the final gas barrier in the VLOS system). These components are shown in Figure 7.1. Both the fast gate and the slide valve had been used previously in the DIAGONAL LINE event.

The experiment tank (or test chamber) consisted of a main cylindrical vacuum tank designed to contain the satellite in a free space environment, a vertical pipe section (to connect to one end of the main cylindrical tank and later to the VLOS pipe) which contained the scatterers, a structure to protect the junction boxes and cables (which connected to the other end of the main vacuum tank), and a "crawler" support system designed to hold the test chamber in place and provide a method of moving the test chamber shortly after zero time from surface ground zero (SGZ) to a position outside of the potential crater area. (Figure 7.2 shows a photograph of these components prior to assembly.) The main experiment tank was above the surface and attached to the VLOS pipe as shown in Figure 7.3.

Two major groups of signal cables were used: those in the downhole cable bundle for device operation and diagnostics, containment closures, and phenomenology measurements; and those cables from experiments in the test chamber to recording instruments in the main instrumentation trailer park. (See Figure 7.4) Most of these cables were designed to be cut (using explosives) immediately after detonation to facilitate movement of the test chamber. The remaining cables were left intact to record post-test (including RAMS) data.

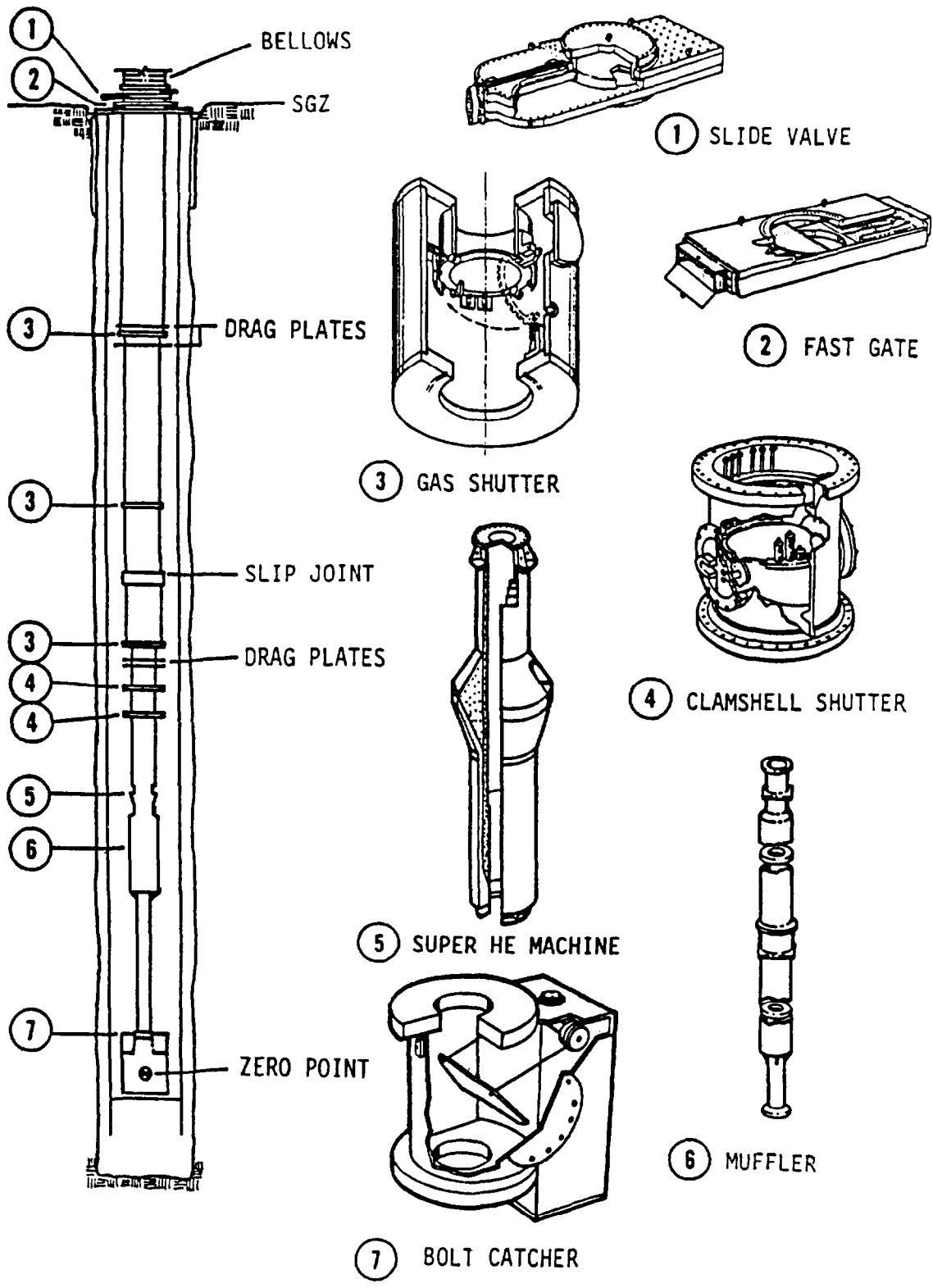

Figure 7.1 HURON KING event - VLOS pipe system.



Figure 7.2 HURON KING event - major components of the experiment tank prior to assembly.

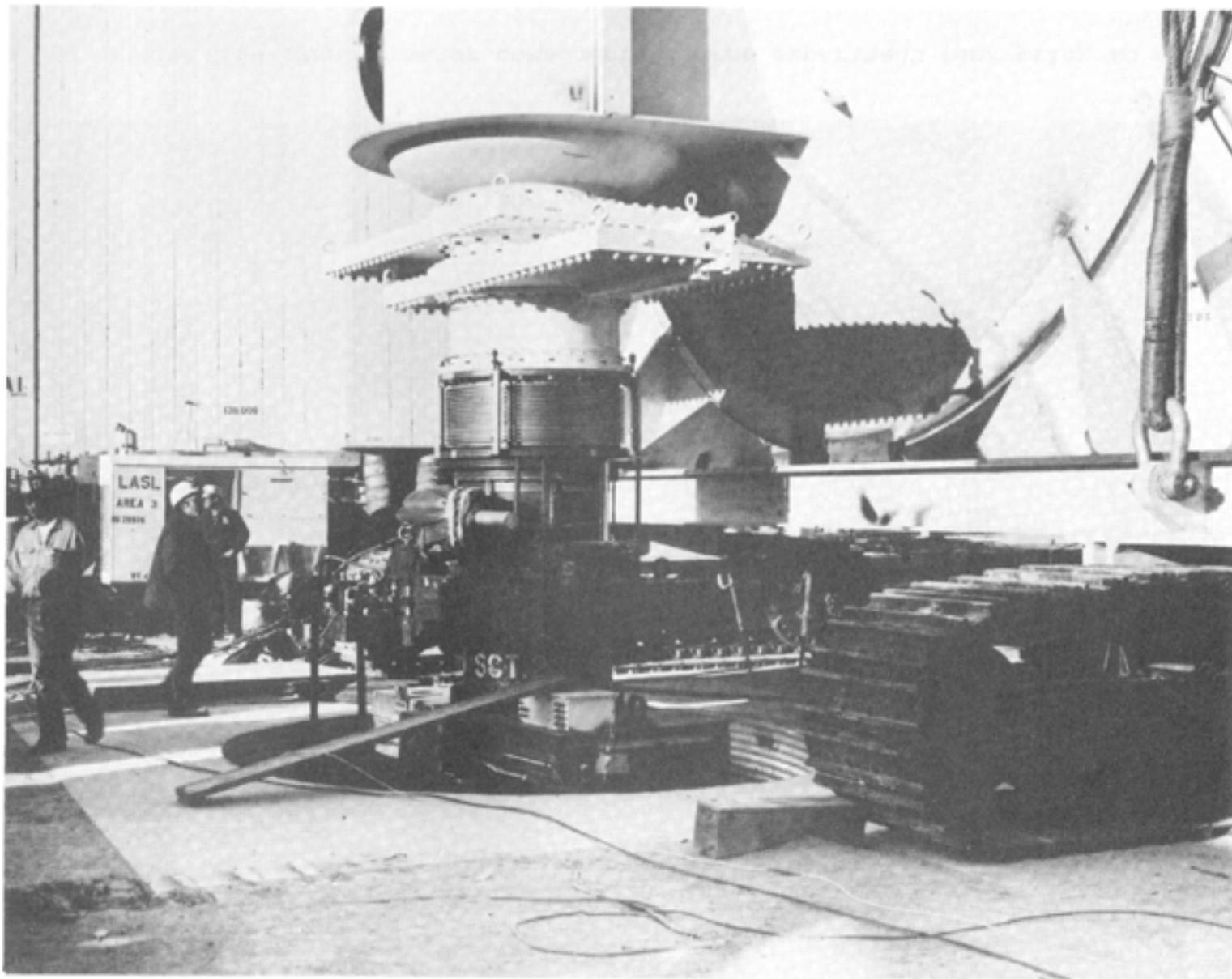

Figure 7.3 HURON KING event - experiment tank positioned over the VLOS pipe system.

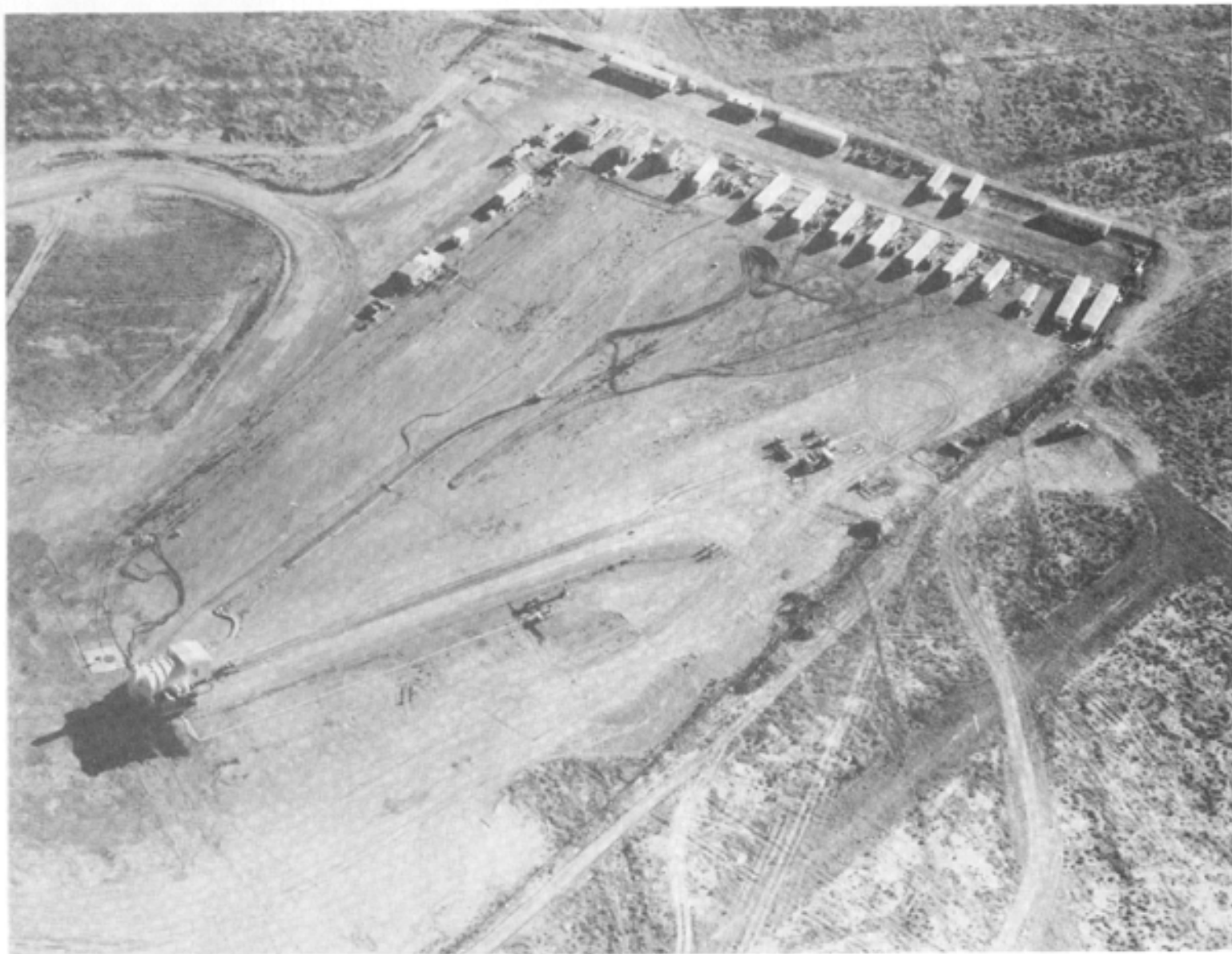

Figure 7.4 HURON KING event - aerial view of U3ky prior to device detonation (the experiment tank is at the lower left, the recording vans and other trailers are at the top).

Instrumentation trailers were used to record information for SAI, GE, JAYCOR, LPARL, SNL, and LANL.

Drilling of the emplacement hole began in April 1979 and was completed in June. Testing of equipment and grading of the area was conducted from June through September, when cable-laying operations were begun. The crawler track and support structure for the experiment tank were delivered and installed in October, and the remaining components of the experiment tank were delivered to the NTS in early November. Surface construction and placement of equipment continued through December 1979.

The experiment tank was assembled and vacuum checked in January 1980. On 17 January, LANL commenced VLOS pipe system downhole dry runs. These dry runs were completed on 6 February. A vacuum check of the VLOS system was successfully completed during 13 and 14 February. On 14 February, the downhole closures were fired and the experiment tank was pulled from the VLOS pipe by the winch system. The VLOS pipe was repressurized and the pipe system was removed from the hole. The closures were refurbished and readied for final installation. SDR's commenced 1 April and were held at least twice a week until execution.

The STARSAT test object arrived on 29 April. Installation into the experiment tank was completed 1 May. (See Figure 7.5.) The device was inserted 7 May, and pipe installation, except for the fast gate and slide valve, was completed by 19 May. The VLOS pipe again was vacuum checked, and stemming commenced on 21 May. Stemming materials included sand, gravel, and various types of concrete. The hole was stemmed completely on 6 June. The fast gate and slide valve were installed, and the experiment tank was positioned over the hole and aligned with the VLOS pipe system on 10 June. A MFP dry run was conducted successfully on 12 June.

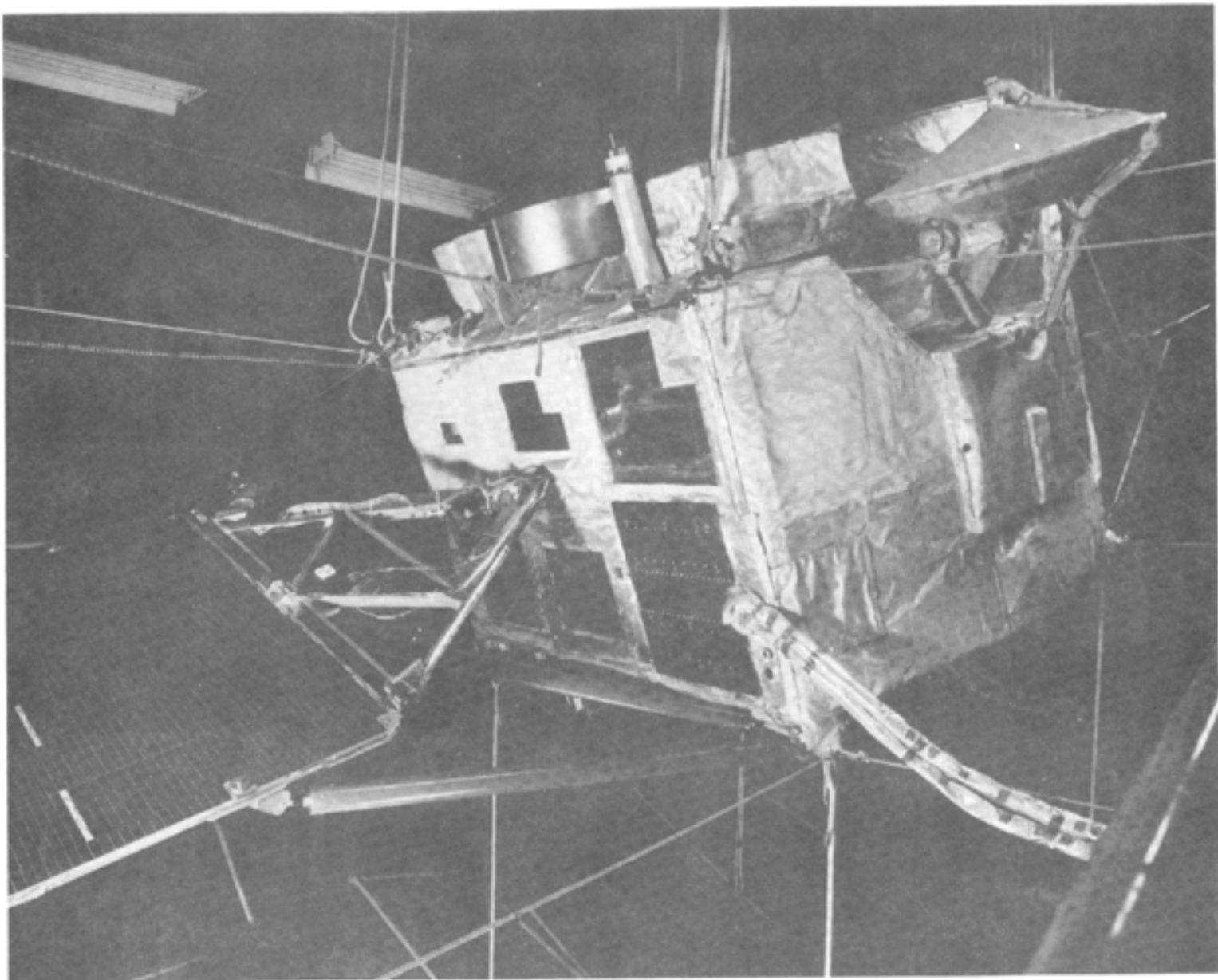

Figure 7.5 HURON KING event - front and left sides of STARSAT.

The personnel access door to the experiment tank was closed on the morning of 20 June (D-4), and the final vacuum pumpdown of the experiment tank and the VLOS pipe system began. An SDR and FDR were conducted successfully on 23 June, and plans were made to detonate at 0800 hours on 24 June. Following these dry runs, explosives were installed for postevent cutting of the vertical pipe section above the bellows (where the VLOS and experiment tank connected) and the steel conduit around the cables and lead shot shielding. Containment, technical, and readiness briefings were held by the DOE Test Controller during the afternoon. Experimenters made all final adjustments and evacuated the U3ky area prior to 2300 PDT on D-1.

B. Radiological Safety Support.

Procedures for radiation exposure and contamination control during this event were in accordance with DOE Manual Chapter 5480.1 and requirements of responsible DOD representatives. Radsafe provided monitoring and equipment support.

Prior to the test, detailed radiological safety reentry plans were prepared and issued to participating agencies. Air sampling equipment was positioned in the test area. Radsafe monitors were briefed regarding reentry, manned stations, and security station requirements.

Radsafe monitoring teams and supervisory personnel were provided to perform initial radiation surveys, conduct aerial surveys by helicopter, and participate in reentry parties as needed. Radsafe personnel also were standing by at Gate 300 prior to detonation to perform surveys and provide emergency support as directed; provide and issue anticontamination equipment and material, portable instruments, and dosimeters; operate area control check

stations; and perform personnel, equipment, and vehicle decontamination, if required.

Available anticontamination materials and equipment included head covers, coveralls, cloth shoe covers, totes, full-face masks, supplied-air breathing apparatus, plastic suits, plastic bags, gloves, and masking tape.

C. Telemetry and Air Sampling Support.

In addition to permanent RAMS units, 16 temporary RAMS units and 8 Model 102 (M-102) air samplers provided surface coverage for HURON KING as shown in Table 7.1 and Figure 7.6. All RAMS and air sampling units were installed a minimum of five days prior to scheduled device detonation.

EPA operated 24 air sampling stations in the offsite area. Thirty-one EPA personnel were fielded for offsite surveillance activities.

D. Security Coverage.

Device security procedures in the zero point area and the timing and firing control room were in accordance with ERDA Manual Chapter 0560, "Program to Prevent Accidental or Unauthorized Nuclear Explosive Detonations." Beginning on D-1, all personnel entering or exiting the controlled area were required to stop at muster or control stations for issue of stay-in badges, or issue and return of muster badges. After area control was established, all through traffic was diverted around the controlled area by use of screening stations.

In accordance with the "Test Controller's Operations and Security Plans," contractors and agencies were to have all personnel not connected with this event out of the

Table 7.1. HURRON KING event RAMS and M-102 unit locations
24 June 1980.

RAMS STATIONS

Station	Location
1	At SGZ
2	85° azimuth, at 344 feet
3	On tank - north
4	On tank - south
5	00° azimuth, at 656 feet
6	30° azimuth, at 676 feet
7	45° azimuth, at 656 feet
8	90° azimuth, at 656 feet
9	120° azimuth, at 656 feet
10	150° azimuth, at 656 feet
11	180° azimuth, at 656 feet
12	210° azimuth, at 656 feet
13	240° azimuth, at 656 feet
14	270° azimuth, at 656 feet
15	300° azimuth, at 656 feet
16	330° azimuth, at 656 feet

M-102 AIR SAMPLING STATIONS

Station	Location
A-1	00° azimuth, at 984 feet
A-2	45° azimuth, at 984 feet
A-3	90° azimuth, at 984 feet
A-4	135° azimuth, at 984 feet
A-5	180° azimuth, at 984 feet
A-6	225° azimuth, at 984 feet
A-7	270° azimuth, at 984 feet
A-8	315° azimuth, at 984 feet

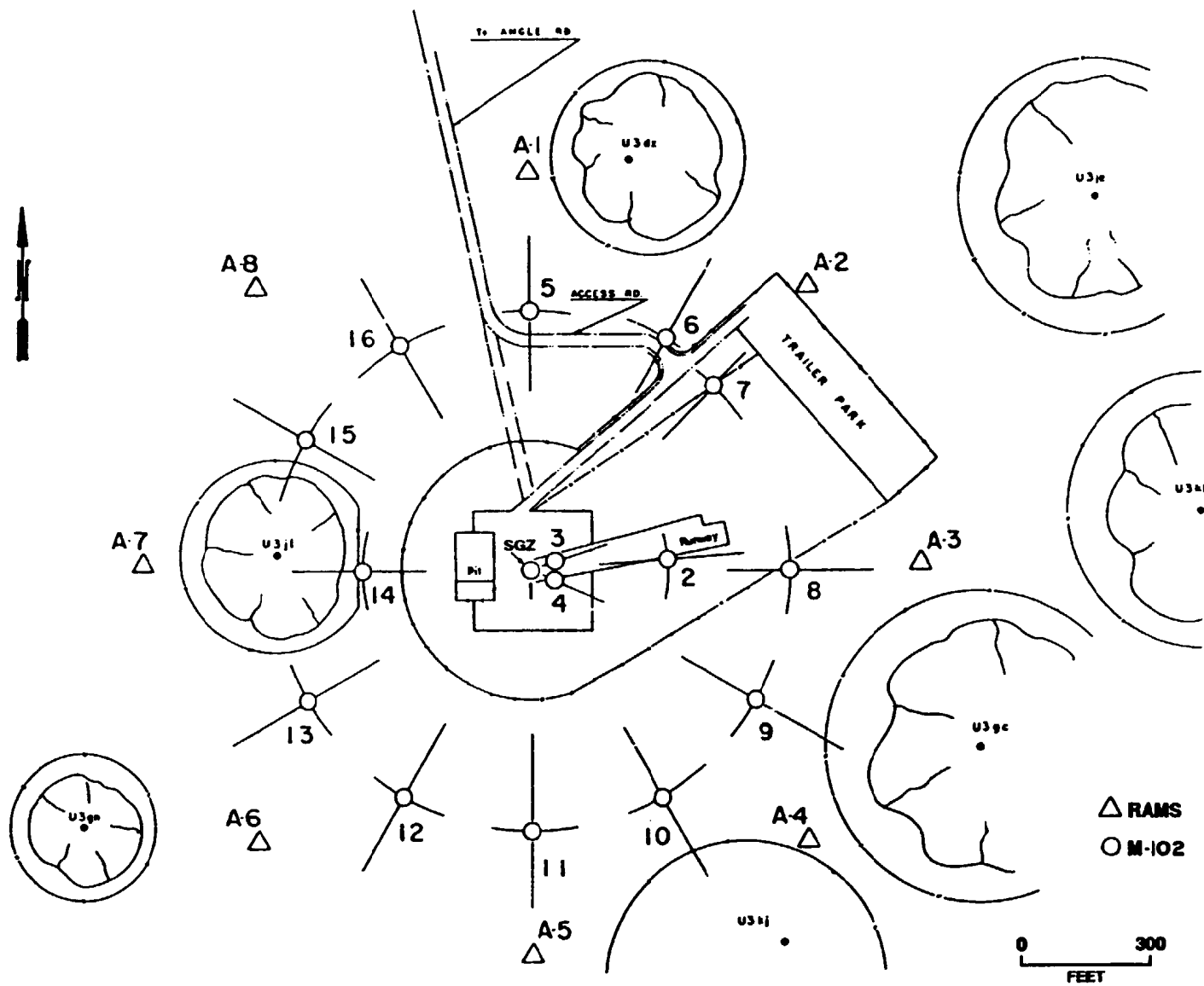

Figure 7.6 HURON KING event - surface RAMS and M-102 units.

closed area before the final security sweep began.

E. Air Support.

Three UH1N helicopters and crews were provided by the USAF for cloud tracking and the Test Controller's use, as requested. In addition, the USAF provided a C-130 and crew on standby status for cloud tracking. The EPA provided an OV-10A Bronco and Turbo Beech aircraft and crew for cloud sampling, if needed. In Las Vegas, another EPA aircraft (C-130) was standing by to undertake tracking duties, if required.

7.3 EVENT-DAY ACTIVITIES.

7.3.1 Preshot Activities.

On 24 June, at 0600 hours, all persons except the arming party, microwave timing party, and security guards were out of the test area and clear of the muster area. At 0615 hours, permission was granted to arm the device. By 0700 hours, all area activity was completed.

A readiness briefing was held at 0600 hours the morning of 24 June in anticipation of planned test execution at 0800 hours that day. Conditions for test execution were favorable and plans to detonate the device continued.

The HURON KING device was detonated at 0810 hours PDT on 24 June 1980, after a ten-minute delay to correct a problem with the RAMS.

7.3.2 Test Area Monitoring.

Telemetry measurements began at 0810 hours on 24 June. The maximum gamma exposure rate detected was at zero time, when 13 R/h at RAMS station No. 1 (at surface ground zero) was observed. Station Nos. 3 and 4 showed 4.7 R/h and 4.4 R/h, respectively.

All stations showed some above-background radiation levels from activation of the VLOS pipe and the experiment tank. By ten seconds after the detonation, all readings had dropped below 1 R/h. All RAMS stations were secured at 1600 hours on 25 June 1980 when the highest radiation reading was 2.5 mR/h at station No. 4 (on the south side of the experiment tank, see Figure 7.8 for postevent tank position).

7.3.3 Initial Surface Radiation Surveys and Recovery Activities.

The experiment tank moved from the top of the VLOS pipe to the desired position as planned immediately after detonation. (See Figures 7.4 and 7.7.) The collapse time of the HURON KING crater occurred at H+50 minutes, 36 seconds. (See Figure 7.8.) Survey teams were released from Gate 300 at 0939 hours on 24 June to do the initial survey of the trailer park. At 1003 hours, Team A had completed its survey. The highest reading during the survey was 5 mR/h, measured at 10 feet from the end of the experiment tank. No radiation escaped to the atmosphere as a result of this test; these radiation readings occurred because the experiment tank had been activated by neutron radiation which had moved up the VLOS pipe at detonation. Repair teams were released to enter the trailer park at 1002 hours, and Radsafe Team B began a more detailed survey of the experiment tank and the surface ground zero area at 1004 hours. A reading of 100 mR/h was measured at the back port of the VLOS pipe at 1010 hours.

At 1012 hours, a security station was established on the road to the entrance of the test area perimeter fence. Recovery teams were allowed to enter the area at 1032 hours, and Radsafe personnel accompanied each of the recovery teams. SNL personnel worked near surface ground zero for approximately three minutes to recover dosimetry packages, where the background exposure rate was 25 mR/h. A reading of 700 mR/h was noted on the top of the VLOS slide valve during this recovery. This was the highest radiation reading noted during recovery. The SNL team was out of the area at 1042 hours.



Figure 7.7 HURON KING event - experiment tank postevent position.

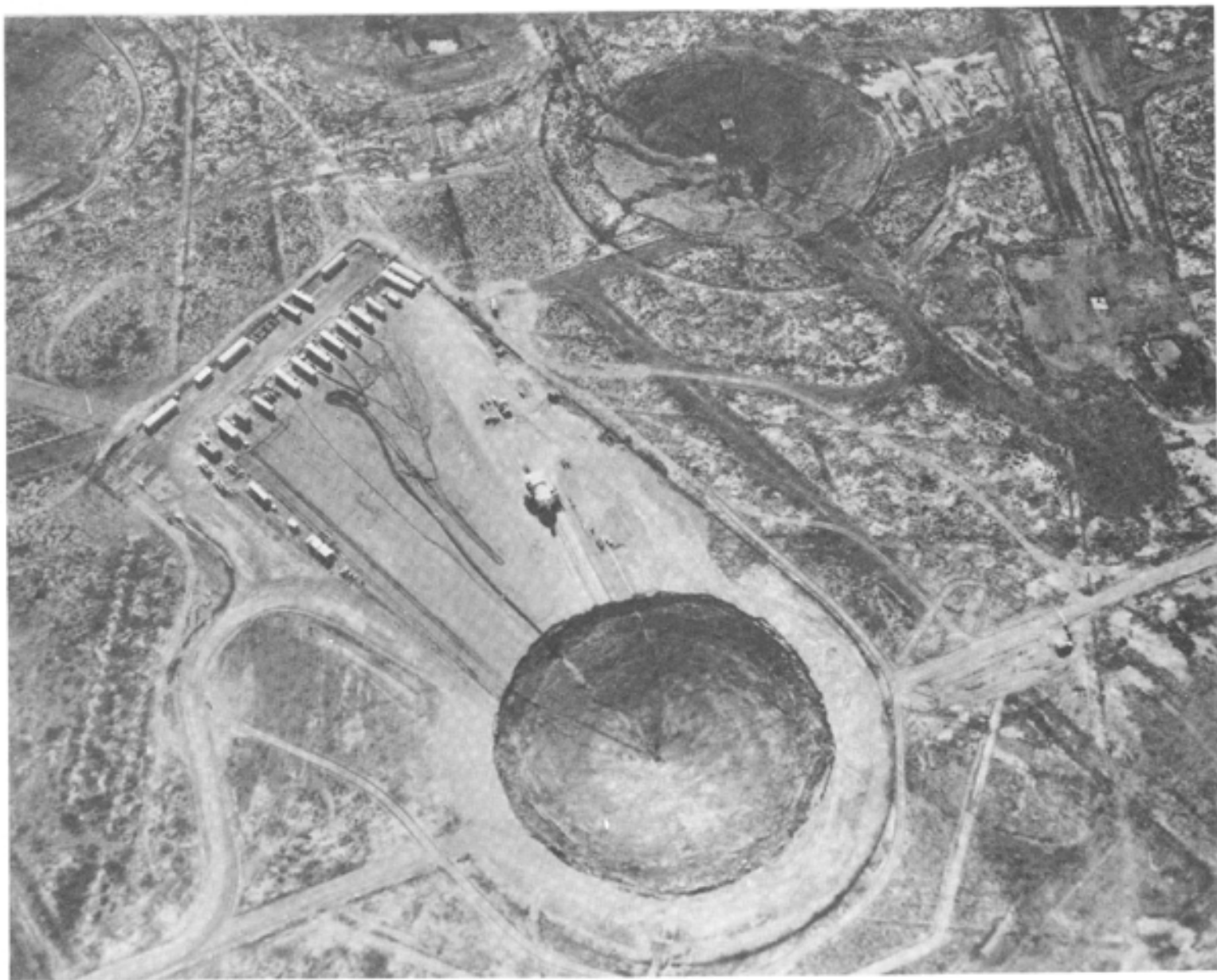

Figure 7.8 HURON KING event - subsidence crater.

The trailer recovery teams entered the test area at 1055 hours. One person, accompanied by a Radsafe monitor, entered the crater for camera recovery at 1117 hours. Full anticontamination clothing and full-face respirators were required. The work area radiation level for this reentry was background, measured at about 20 feet from surface ground zero. All personnel had exited the crater by 1140 hours.

The vacuum on the experiment tank was removed, and at 1247 hours, industrial hygiene personnel verified that there was no positive LEL level or toxic gas in the tank. A survey at 1255 hours of the VLOS pipe showed it also was free of any LEL level or toxic gas. At 1310 hours, the ports were opened on the experiment tank and recoveries commenced. All recoveries were completed by 1322 hours with a maximum recorded reading of 16 mR/h noted at contact with the ports. Work began to open the manway door to the experiment tank at 1327 hours. At 1337 hours, this door was opened; a 10 mR/h radiation level was noted, but no LEL level or toxic gases were observed. At 1400 hours, the manway door was closed, and by 1435 hours, all personnel had departed the area. Radsafe personnel continued to survey at the perimeter fence for possible radiation leaks each half hour until 2400 hours on D-day.

The five-foot door on the experiment tank was opened by DOD personnel at 0750 hours on 25 June 1980. Readings from the interior ranged from 0.1 to 0.2 mR/h. At 0755 hours, the six-inch port to the top of the tank was opened, and readings ranged from 0.08 to 0.13 mR/h. A party of visitors entered the perimeter fence to inspect the crater at 0802 hours. The inspection was completed at 0818 hours and all personnel left the area. At 0930 hours, industrial hygiene personnel checked the oxygen level in the experiment tank. Because the level was below normal, when reentry of the tank occurred at 1144 hours, both members of the reentry team wore self-contained breathing apparatus. This reentry was completed at 1208 hours with no problems. Seven thermoluminescent dosimeters (TLDs) were recovered. No removable contamination was noted inside the tank, and the work area

exposure rate in the tank was 0.5 mR/h. The highest radiation level noted on the satellite was 1.5 mR/h.

At 1320 hours, DNA personnel wearing full-face respirators, hoods, coveralls, gloves, and totes recovered the lithium hydride scatterer from the LOS pipe extensions (which are equivalent to the LOS stubs). This material showed a radiation level of 0.3 to 0.5 mrad/h, and was disposed of at the U3ax radioactive waste facility. Reentry into the experiment tank and crater were performed as requested, and equipment was surveyed by Radsafe and released throughout the remainder of this day and through 30 June. On 30 June, the inside of the experiment tank was vacuumed because some airborne lithium hydride had been noted.

Ground motion detection equipment from the crater and some TLD's from the experiment tank were removed on 1 July. Tours and recovery parties were accompanied by Radsafe personnel as requested throughout July. Full anticontamination clothing requirements continued for all entries into the experiment tank. An entry was made on 14 July by carpenters measuring the inside of the experiment tank to install a floor. On 1 August, the carpenters installed the floor in the experiment tank, which was then surveyed thoroughly and released to DNA from Radsafe control.

7.4 POSTEVENT ACTIVITIES.

7.4.1 Post-Recovery Activities.

A crater entry was made on 20 August. Laborers began clearing earth from around the LOS pipe, and by 1250 hours iron workers had access to the flange bolts on top of the LOS pipe. At 1430 hours, the top valve was pulled. No radiation problems were encountered, and the work area radiation rate was at background. Laborers began to clean around the second valve.

On 28 August, pipefitters partially opened the fast gate in the VLOS pipe. A portable radiation instrument probe was lowered down the pipe to 256 feet. A trace of contamination was noted

between 35 and 40 feet. A plate was installed on top of the pipe to secure it until operations could be completed.

A complete exterior surface survey of the satellite was conducted on 9 September by Radsafe personnel. No above-background radiation levels were noted during this survey.

On 3 October, work resumed at the U3ky site. The laborers finished clearing around the second valve at the top of the VLOS pipe. At 1145 hours, the flange was opened, and the radiation level was at background. Another portable instrument probe was lowered down the pipe to 286 feet. Traces of radiation were noted along the pipe. At 280 feet, the radiation level increased to 0.5 mR/h. The pipe was secured at 1220 hours.

On 6 October, a run with a television camera was made down the VLOS pipe. After this survey was completed, the camera was checked and found free of radioactive contamination. A second series of four camera runs were conducted on 7 October, reaching a depth of 211 feet. This completed all of the activity conducted for the HURON KING event.

7.4.2 Postevent Drilling.

No postevent drilling to collect zero point core samples was conducted for this event.

7.4.3 Industrial Safety.

Appropriate safety measures were taken to protect construction and craft personnel and prevent unsafe conditions. Industrial safety codes were established by REECO and emphasized during all operations. A written standard operating procedure was required for each operation involving explosives, toxic materials, radioactive material, or any other operation with the potential for personal injury. Each individual involved in such an operation was required to know the contents of the applicable procedures.

The entire testing area before and after the event was a mandatory hard hat and foot protection area (safety shoes, safety boots, DOE-issued miners boots, or toe guards).

All explosives, electro-explosive components, solid propellants, toxic materials, and radioactive materials were handled, stored, and transported in accordance with applicable sections of the following documents:

1. Army Materiel Command Regulations (AMCR 387-224).
2. AEC Manual 0500 Series for the Nevada Test Site.
3. Individual Safe Operating Procedures (by experimenter organization).
4. FCTD HURON KING Safety Instructions.

All personnel engaged in handling, storing, assembling, or installing explosives, propellants, or electro-explosive devices (or observers of those operations) were required to wear safety glasses or other eye protection which had been approved by the DOD Safety Coordinator.

7.5 RESULTS AND CONCLUSIONS.

Telemetry measurements began at 0810 hours on 24 June. The highest recorded reading was 13 R/h, measured at zero time at station No. 1. All stations were secured by 1600 hours on 25 June. No radiation other than that from expected neutron activation was detected by telemetry units.

The initial radiation survey of the test area began at 0939 hours on D-day and was completed by 1003 hours. The highest exposure rate detected was 5 mR/h, measured near the experiment tank. The highest radiation reading during recovery operations was 700 mR/h, noted on the top of the VLOS slide valve on 24 June. The highest work area exposure rate observed was 25 mR/h, measured near surface ground zero on 24 June during recovery of dosimetry packages by SNL personnel. No positive LEL level or toxic gases were noted during any operation. No

postevent drilling for ground zero core sample recovery was accomplished for this event.

Personnel exposure data from self-reading pocket dosimeters were documented on Area Access Registers during individual entries to HURON KING radex areas on 24 June 1980 (the only day when Area Access Registers were used). A total of 515 entries into radex areas was recorded, 95 of which were made by DOD-affiliated participants. Although pocket dosimeters showed some indication of possible radiation exposure, film badges worn by recovery personnel (those most likely to be exposed) indicated no evidence of any gamma exposures. The minimum detectable gamma exposure with the NTS film dosimeter was 30 mR.

SECTION 8

MINERS IRON EVENT

8.1 EVENT SUMMARY.

MINERS IRON was the tenth event in the Hussar Sword Series sponsored by DOD and was conducted at 1000 hours Pacific Standard Time (PST) on 31 October 1980 with a yield of less than 20 kilotons. The device was detonated in the U12n.11 drift of the N tunnel complex (Figure 8.1) at a vertical depth of 1,306 feet. The purpose of the event was to test the response of materials and equipment to a nuclear detonation environment, specifically, to simulate the effect of a Soviet antiballistic missile on an MX missile in space. An evacuated horizontal LOS pipe 1,145 feet long was used to house experiments. Forty-one projects were fielded for the event.

Stemming was successful and containment was complete. The closure system within the LOS pipe did not contain all of the radioactive gases generated by the test, and the inside of the LOS pipe was slightly contaminated. No radioactive effluent from the test was detected onsite or offsite.

8.2 PREEVENT ACTIVITIES.

8.2.1 Responsibilities.

Safe conduct of all MINERS IRON project activities in Area 12 was the responsibility of the DOD Test Group Director. Responsibilities of DOE and DOE contractor personnel were in accordance with established DOE-DOD agreements or were the subject of separate action between Field Command/DNA, and the DOE Nevada Operations Office.

Project agencies were responsible for designing, preparing, and installing experiments or delivering them to the installation contractor. After the event, these agencies were responsible for

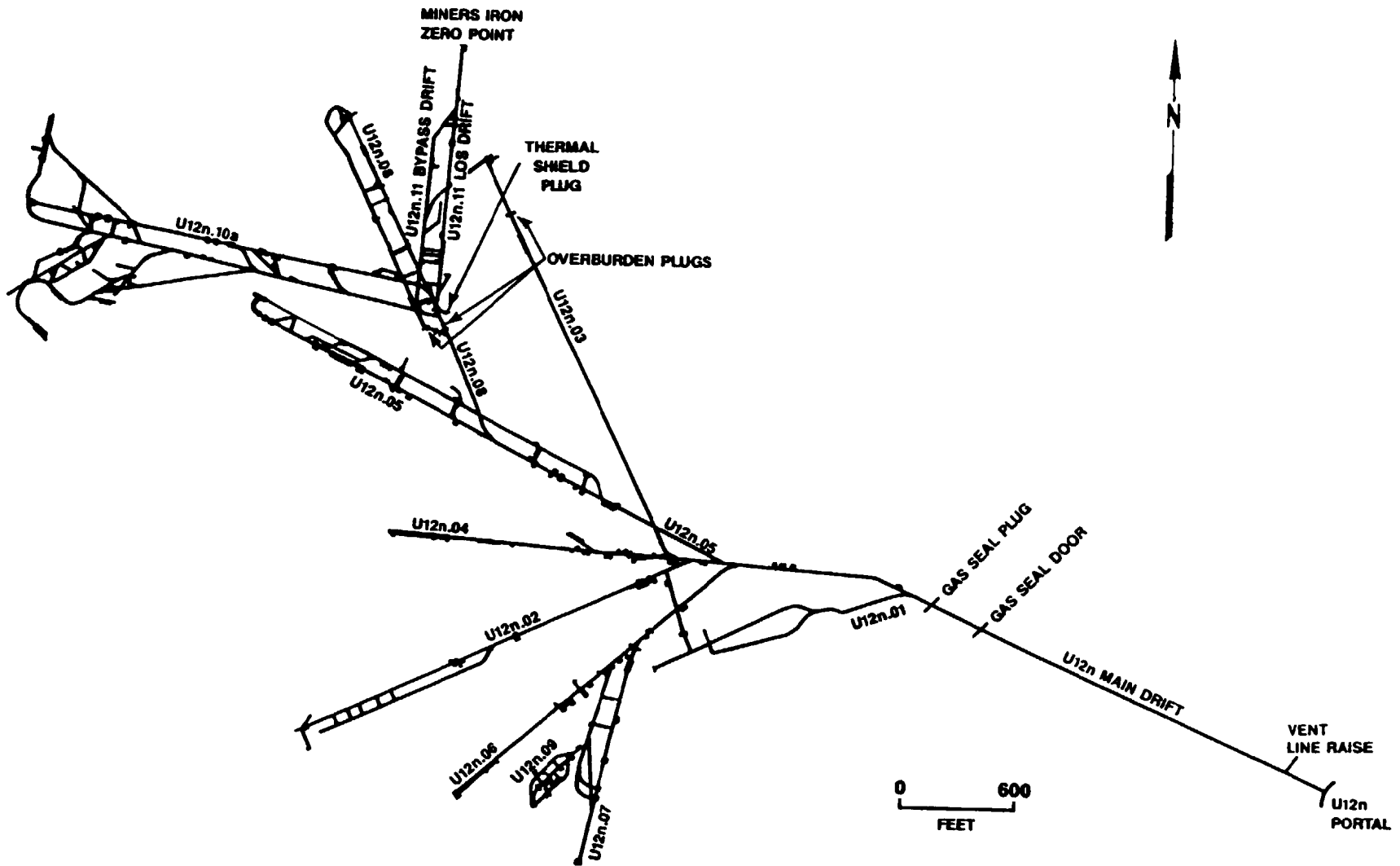

Figure 8.1 MINERS IRON event - tunnel layout.

removing samples, analyzing instrument and sample data, and preparing project reports on experiment results.

Device safety and security procedures in the zero point area and the timing and firing control room were in accordance with ERDA Manual Chapter 0560, "Program to Prevent Accidental or Unauthorized Nuclear Explosive Detonations." Because LANL fielded the device, the LANL Test Group Director was responsible for radiological safety within a 6,000-foot radius of the zero point from device emplacement until detonation. After detonation, the DOE Test Controller relieved the LANL Test Group Director of responsibility. When the Test Controller determined that venting had not occurred, he delegated responsibility for radiological safety to the DNA Test Group Director.

8.2.2 Planning and Preparations.

A. Tunnel Facilities Construction.

The U12n.11 complex was configured so that the three existing overburden plugs (OBPs) from the DIABLO HAWK event could be reused. A total of six plugs between the LOS pipe and the portal were part of the MINERS IRON containment features. These included the main drift OBP (see Figure 8.2), cable gas block OBP, U12n.03 OBP, ventilation drift thermal shield plug, gas seal plug, and structures downhole plug. Additional containment features included a gas seal door, stemming of the main cable hole, and gas blocks (at the cable splice alcove).

The LOS pipe system was composed of an 1,145-foot LOS pipe containing a zero room, a muffler, two MACs, a TAPS, two small bulkhead stations, two sieve/filter combinations, two fluence stations, three test chambers, a stub pipe system, two vacuum pumping modules, a shock mounting system, and shock decouplers. Many of these items were recovered from the DIABLO HAWK event. (See Figure 8.3.)



Figure 8.2 MINERS IRON event - OBP before concrete pour.

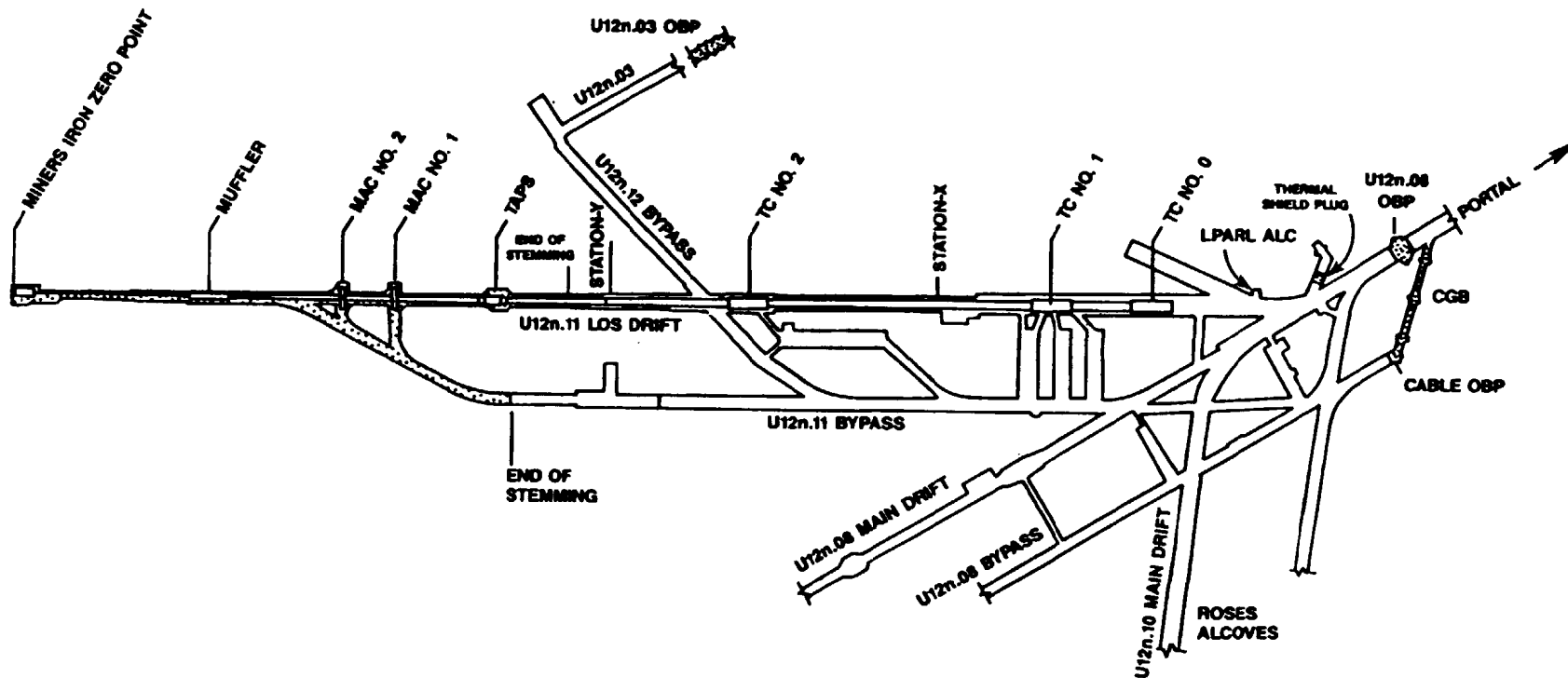

KEY

- TC - TEST CHAMBER
- MAC - MECHANICAL ACTION CLOSURE
- OBP - OVBURDEN PLUG
- CGB - CABLE GAS BLOCK
- ALC - ALCOVE
- STA - STATION
- TAPS - TUNNEL AND PIPE SEAL

Figure 8.3 MINERS IRON event - tunnel and pipe layout.

Mining operations for the MINERS IRON test complex commenced in April 1979 and were completed in September 1979. Installation of the LOS pipe began in November 1979 and was completed and vacuum checked in September 1980. Labor problems in June and July of 1980 prevented the LOS pipe from being vacuum checked in its entirety prior to the start of experiment installation in May 1980. SDR's commenced on 26 August 1980 and continued until the FDR on 30 October. A successful MFP dry run was completed on 15 October and the device was emplaced on 16 October. Final button-up stemming operations were initiated that same day.

Data from all active experiments were recorded by oscilloscope cameras and/or magnetic tape recorders installed in instrumentation vans located on Rainier Mesa or in ROSES units located in the U12n.10a drift.

Experimenters included SNL; AFWL; SAI; Corrales Applied Physics Company (CAPco); DNA; Effects Technology, Inc. (ETI); AFWL/ETI; LANL; LPARL; Field Command Test Management; Engineering (FCTME); Field Command; Test Construction (FCTC); AFWL/PI; Aerojet, McDonald Douglas Aircraft (MDAC); Mission Research Corporation (MRC); LLNL; Atomic Weapons Research Establishment (AWRE); KSC; and AFWL/BMO (Ballistic Missile Office).

B. Radiological Safety Support.

Procedures for radiation exposure and contamination control during this event were in accordance with DOE Manual Chapter 5480.1 and requirements of responsible DOD representatives. Radsafe provided monitoring and equipment support.

Prior to the test, detailed radiological safety reentry plans were prepared and issued to participating agencies. Air sampling equipment was positioned in the

test area. Radsafe monitors were briefed regarding surface reentry, manned stations, and security station requirements.

Radsafe monitoring teams and supervisory personnel were provided to perform initial radiation surveys, conduct aerial surveys by helicopter, and participate in reentry parties as needed. Radsafe personnel also were standing by at Gate 300 prior to detonation to perform surveys and provide emergency support as directed; provide and issue anticontamination equipment and material, portable instruments, and dosimeters; operate area control check stations; and perform personnel, equipment, and vehicle decontamination, as required.

Available anticontamination materials and equipment included head covers, coveralls, cloth shoe covers, totes, full-face masks, supplied-air breathing apparatus, plastic suits, plastic bags, gloves, and masking tape.

C. Telemetry and Air Sampling Support.

In addition to permanent RAMS units, 40 temporary units provided surface and underground coverage for MINERS IRON as shown in Table 8.1 and Figures 8.4 and 8.5. Also, an air sampling unit was placed at the tunnel portal. All RAMS units and the air sampling unit were installed a minimum of five days prior to scheduled device detonation.

EPA operated 110 air sampling stations in the offsite area. Thirty EPA personnel were fielded for offsite surveillance activities.

D. Security Coverage.

Device security procedures in the zero point area and the timing and firing control room were in accordance with ERDA Manual Chapter 0560, "Program to Prevent Ac-

Table 8.1. MINERS IRON event RAMS unit locations
31 October 1980.

SURFACE

Station	Location
	<u>From the U12n portal:</u>
1	At the portal
2	On the filter system
3	On the vent line
4	On the tunnel drain line
5	400 feet N 16° E azimuth
6	275 feet N 89° E azimuth
7	365 feet S 16° E azimuth
8	480 feet S 12° W azimuth
9	560 feet S 48° W azimuth
10	420 feet N 69° W azimuth
11	1,370 feet S 43° E azimuth
	<u>From the cable downhole unless otherwise indicated:</u>
12	At cable downhole (cable raise building)
13	180 feet N 42° E azimuth
14	140 feet S 34° E azimuth
15	370 feet S 31° W azimuth
16	80 feet N 85° W azimuth
17	At the vent hole
	<u>From the U12n.11 SGZ unless otherwise indicated:</u>
18	500 feet N 00° E azimuth
19	500 feet S 61° E azimuth
20	500 feet S 61° W azimuth
SCH	Structures cable hole

Table 8.1. MINERS IRON event RAMS unit locations
31 October 1980 (Continued).

UNDERGROUND

<u>Station</u>	<u>Location</u>
	<u>From the U12n.08 drift unless otherwise indicated:</u>
21	575 feet into the U12n.11 LOS drift
22	275 feet into the U12n.11 LOS drift
23	157 feet into the U12n.11 LOS drift
24	450 feet into the U12n.11 bypass drift
25	250 feet into the U12n.11 bypass drift
26	185 feet into the U12n.10a drift
27	85 feet into the U12n.08 bypass drift S curve
*28ER	85 feet into the U12n.08 bypass drift S curve
29	In the U12n vent drift
30	435 feet into the U12n.08 drift from the 05 drift
31	600 feet into the U12n.05 drift from the U12n main drift
32	300 feet into the U12n.03 drift from the U12n main drift
	<u>From the U12n portal unless otherwise indicated:</u>
33	2,600 feet into the U12n main drift
34	2,050 feet into the U12n main drift
*35ER	2,050 feet into the U12n main drift
36	1,700 feet into the U12n main drift
37	1,200 feet into the U12n main drift
38	50 feet into the U12n vent line raise from the U12n main drift
39	200 feet into the U12n main drift

* ER - Extended Range (instrument capable of reading 100 mR/h to 100,000 R/h)

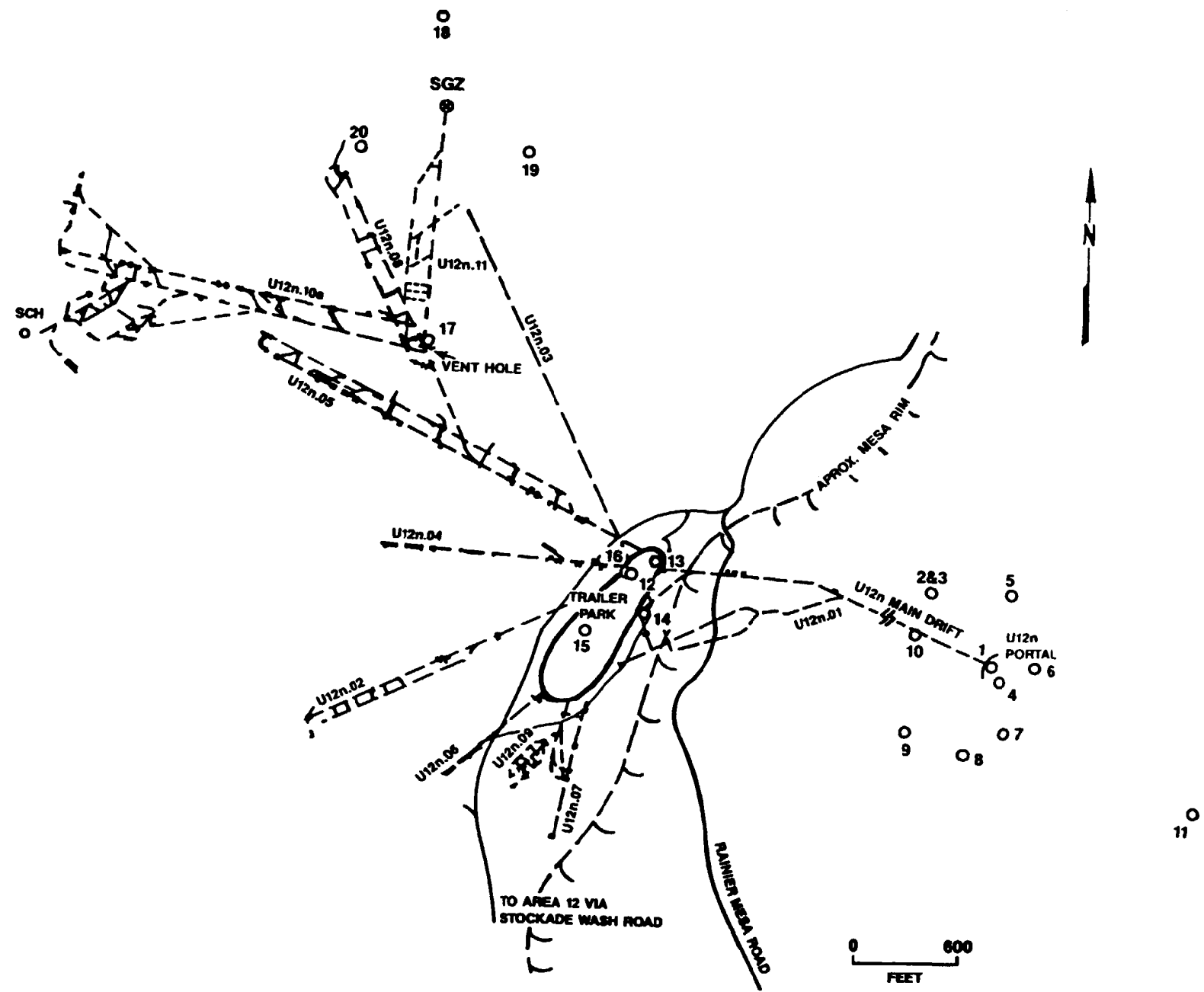

Figure 8.4 MINERS IRON event - surface RAMS.

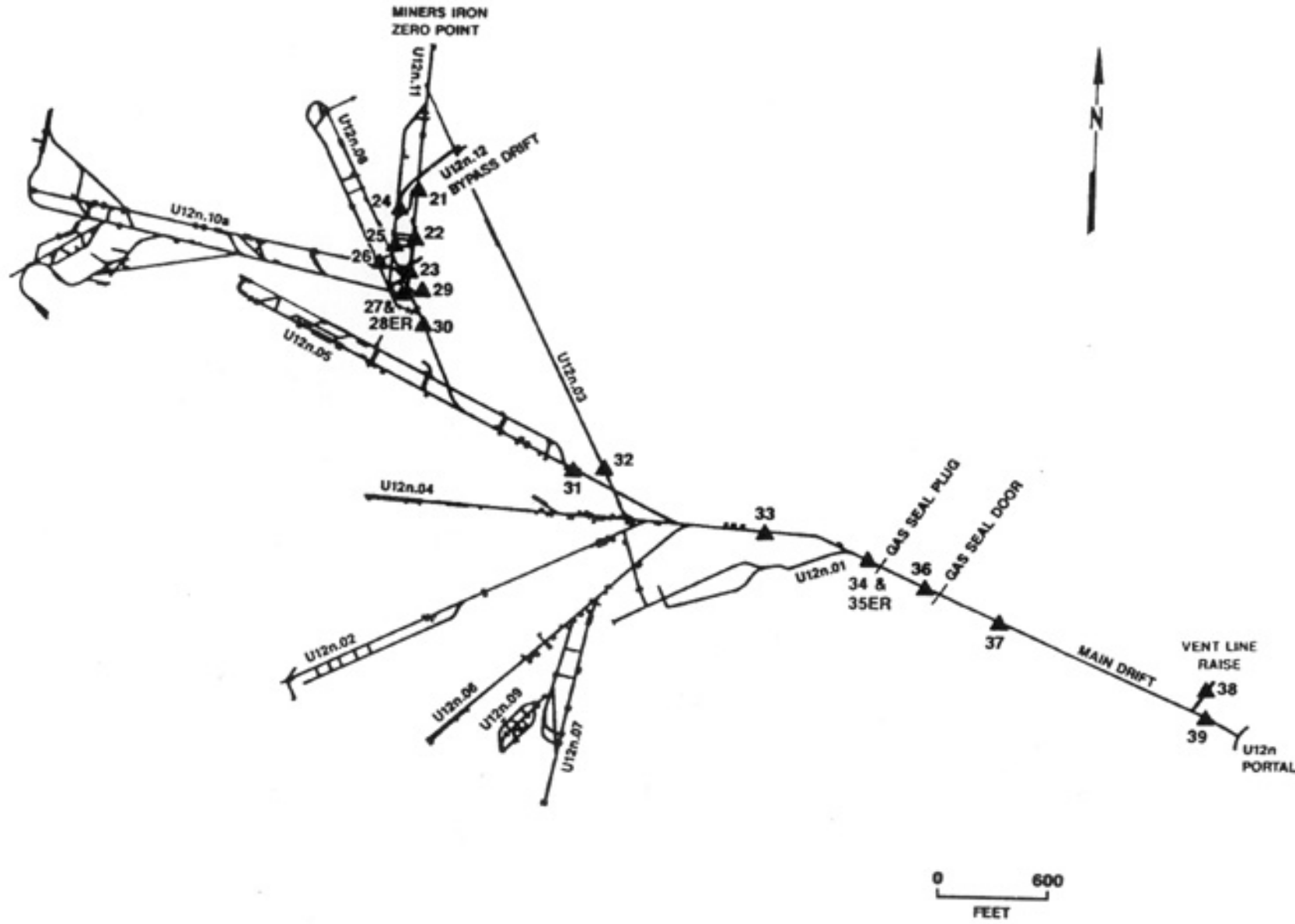

Figure 8.5 MINERS IRON event - underground RAMS.

cidental or Unauthorized Nuclear Explosive Detonations." Beginning on D-1, all personnel entering or exiting the controlled area were required to stop at muster or control stations for issue of stay-in badges, or issue and return of muster badges. After area control was established, all through traffic was diverted around the controlled area by use of screening stations.

In accordance with the "Test Controller's Operations and Security Plans," contractors and agencies were to have all personnel not connected with this event out of the closed area before the final security sweep began.

E. Air Support.

Three UH1N helicopters and crews were provided by the USAF for cloud tracking and the Test Controller's use, if needed. In addition, the USAF provided a C-130 and crew on standby status for cloud tracking. The EPA provided a Turbo Beech and crew for cloud sampling. Another EPA aircraft, an OV-10A Bronco, was used for obtaining meteorological information before the test and was on standby after the test to undertake a cloud tracking mission, if required.

8.3 EVENT-DAY ACTIVITIES.

8.3.1 Preshot Activities.

On 31 October 1980 at 0001 hours, all persons except the arming party, tunnel button-up party, microwave timing party, and security guards were out of the tunnel and clear of the muster area. Permission was granted to arm the device, arming was accomplished, and button-up was completed.

A readiness briefing was held at 0630 hours on 31 October in anticipation of planned test execution at 1000 hours that day. Conditions for test execution were favorable, and all personnel were mustered out of the area.

The MINERS IRON device was detonated at 1000 hours PST on 31 October 1980.

8.3.2 Test Area Monitoring.

Telemetry measurements began at 1000 hours on 31 October 1980. All stations remained operational throughout the test with the exception of RAMS unit No. 21, which was inoperative at zero time and remained inoperative throughout the test. All stations showed background radiation levels after the test with the exception of unit Nos. 22 and 23, which were placed in the LOS drift and responded as expected to activation radiation. RAMS unit No. 22 read a maximum of 540 R/h at H+1 minute, decreasing to 3.3 R/h by 1102 hours on 31 October 1980. Unit No. 23 read a maximum of 512 R/h at H+1 minute, decreasing to 1.3 R/h by H+1 hour. The reading at unit No. 23 had decreased to 1 R/h by 1200 hours on 31 October 1980. No indications of radioactive effluent were detected by any tunnel, surface, or airborne radiation monitoring units. All RAMS units were secured at 1100 hours on 3 November 1980, when RAMS unit No. 22 read 11 mR/h and No. 23 read 9 mR/h.

8.3.3 Initial Surface Radiation Surveys and Recovery Activities.

Four reentry teams (one team each to survey the main Mesa trailer park, Mesa ventilation pad, portal area, and portal area ventilation system) were released from Gate 300 at 1055 hours on the day of detonation. The portal area surveys were completed at 1136 hours, the Mesa ventilation pad survey was completed at 1139 hours, and the Mesa trailer park survey was completed at 1141 hours. No radiation levels above background (0.05 mR/h) were detected. Gas samples obtained remotely from the zero point side of the OBP indicated no above-background level of radioactivity, toxic gases, or the LEL. However, levels of 150 mrad/h (beta plus gamma), 800 ppm of carbon monoxide, and 27 percent of the LEL were noted in gas samples drawn from test chamber No. 2. Mesa and portal data recoveries were conducted between 1630 and 2000 hours after cable disconnects at the Mesa

splice shack were completed. D-day operations were terminated at 2000 hours.

8.4 POSTEVENT ACTIVITIES.

8.4.1 Tunnel Reentry Activities.

Remote gas sampling was performed again the morning of 1 November 1976 (D+1), before any personnel entered the tunnel. Gas samples from inside the LOS pipe read 0.2 mR/h (3 mrad/h) at contact. One-hundred percent of the LEL and 5,000 ppm of carbon monoxide were measured. At 0825 hours, a work party accompanied by Radsafe and industrial hygiene personnel entered the tunnel and proceeded to the gas seal door. No anticontamination clothing was required. The gas seal door was opened, and the work party moved to the gas seal plug. The 36-inch crawl space in the plug was opened, and air flow towards the portal was noted. Surveys showed a 0.04 mrad/h radiation level, no indication of any LEL level or carbon monoxide, and 300 ppm of carbon dioxide. Ventilation was established through this plug. The work party returned to the portal at 1035 hours with no above-background LEL or radiation level having been encountered, and only the above-mentioned low level of carbon dioxide noted.

Reentry team No. 1, accompanied by the rescue team, entered the tunnel at 1103 hours wearing full anticontamination clothing, which included gloves, coveralls with openings taped, a hood, and totes. (No respiratory protection was required to the OBP.) Damage to the tunnel was noted as the teams moved toward the OBP. After the OBP was reached, the air from the zero point side of the OBP was sampled through the plug manual gas sampling line. No above-background radiation, LEL, or toxic gas level was observed. The 36-inch door to the crawl space in the OBP was opened, the ventilation lines through the OBP were hooked up, and, at 1352 hours, reentry team No. 1 moved through the plug, each member wearing SCBA.

Damage was noted in all areas. At the door of test chamber No. 2, 80 mrad/h was measured; no indications of any LEL level or

toxic gases were observed. An attempt was made to establish ventilation to the LOS pipe at test chamber No. 2, but the flex line which had been installed before detonation to the exhaust valve on the LOS pipe was badly shredded during the event and was unusable. At 1520 hours, the team had moved back to the OBP. Before exiting the tunnel and while still wearing SCBA, the team worked on a problem with the ventilation system. They were ordered back to the portal at 1602 hours. The team exited the tunnel at 1630 hours.

The reentry team, work team, and rescue team reassembled the next morning to continue the reentry. Readings from the remote gas sampling line showed that a 0.3 mrad/h radiation level, 100 percent of the LEL, and 2,000 ppm of carbon monoxide remained inside the LOS pipe. At 0850 hours, the train left the portal. At 0944 hours, the reentry team again passed through the OBP. The team corrected the ventilation problem not completed the day before, opened the Mesa vent line, and measured 50 ppm of carbon monoxide. No other above-background readings were observed. At 1036 hours, the Mesa blower was started to reestablish tunnel ventilation. The reentry team, having previously returned to the portal side of the OBP and removed their SCBA, redonned their breathing apparatus and passed back through the OBP at 1107 hours to continue reentry. They again moved to test chamber No. 2 and set up a flex line to the valve at the top of the test chamber. The radiation reading at the door was 30 mR/h (50 mrad/h). The valve was opened; 100 percent of the LEL and about 1,500 ppm of carbon monoxide were measured.

The team moved to test chamber No. 0. The door was opened, and a reading of 40 mR/h was taken at arm's length inside the chamber. No positive LEL level or toxic gases were noted. The team walked to the ROSES drift where they were allowed to remove their SCBA. Ventilation was established into the ROSES area. Some damage was noted, and all the ROSES units were tilted somewhat. At 1229 hours, the backup reentry team entered the tunnel. The freon bottles in the ROSES units were turned off and the freon drained according to the reentry plan. All reentry

personnel had returned to the portal side of the OBP by 1315 hours.

At 1400 hours, recovery teams were allowed to enter the tunnel. No protective clothing or respiratory protection gear was required as no toxic gases, LEL level, or removable contamination had been measured in the recovery areas (the ROSES and stubs areas). By 1830 hours, initial recoveries had been made, and all the recovery teams had been checked for contamination and allowed to depart the area. All personnel had exited the tunnel at 2000 hours on D+2.

On 3 November, remote gas samples again were taken from inside of the LOS through the sampling lines to the tunnel portal. Inside the LOS pipe, the radiation level had dropped to 0.04 mrad/h, although indications of 925 ppm of carbon monoxide and 75 percent of the LEL still remained. The train left the portal at 0900 hours with Radsafe personnel and miners. A "hot line" was set up on the zero point side of the OBP. A flex line was run through the OBP to test chamber No. 2 to provide ventilation to the TAPS area. A reentry team and the rescue team departed for test chamber No. 2. The work area radiation level outside test chamber No. 2 was 9 mrad/h, with the highest reading being 50 mR/h, made at contact with the LOS pipe on the zero point side of the test chamber door. A flex line was hooked up to ventilate inside the LOS pipe at the TAPS area, and the reentry team donned SCBA to enter to the TAPS with the flex line. The door to test chamber No. 2 was opened and the team entered the pipe. An exposure rate of 6 mR/h was noted inside the pipe. No LEL level was noted, but a trace of carbon monoxide was measured.

The team arrived at the TAPS at 1107 hours. The LEL level was 100 percent, and 5,000 ppm of carbon monoxide was noted at a leak at the top of the TAPS. The flex line was placed to remove the toxic and potentially explosive gases leaking from the top of the TAPS, swipe samples were taken, and the reentry team left the LOS pipe at 1130 hours. Results of the swipe samples taken

showed the presence of removable contamination inside the LOS pipe.

A scientific assessment team and LANL and SNL personnel, each person wearing full anticontamination clothing, entered test chamber No. 0 at 1220 hours to assess damage and take photographs. The general exposure level was 16 mrad/h, with the highest exposure rate of 90 mR/h measured at contact with area experiments. At 1240 hours, the team entered test chamber No. 1. The work area radiation level was 3 mrad/h. The team moved on to test chamber No. 2. The highest radiation level measured was 110 mrad/h, noted at contact with the experiments. The work area radiation level was 6 mrad/h. The LANL and SNL personnel left the pipe at 1400 hours, and the scientific assessment teams left at 1620 hours. All were surveyed after they removed their anticontamination clothing to make sure they had not contaminated themselves inside the test chamber; all were free of contamination.

Work began to remove the containment plugs on swing shift of 3 November. Assessment teams again entered the LOS pipe on 4 November at 0845 hours, and recovery teams began test chamber recoveries at 0910 hours the same day. Radsafe monitors and industrial hygiene personnel conducted each recovery group into their respective area. All personnel left the test chambers by 1330 hours that day. Mining continued on 5 and 6 November to remove the gas seal plug and OBP. Assessments of damage were made and more photographs were taken on 6 and 7 November. Rehabilitation of the damaged areas began 7 November and continued for several weeks. On 12 November, recovery parties again entered the test chambers. All experiments were bagged and shipped out of the tunnel as contaminated materials, and the experiments were then decontaminated by Radsafe personnel at the SRD (Secret Restricted Data) building in Area 12. Recoveries continued through 21 November. Some removal of experiments and equipment occurred after this time as the users directed; all experiments were checked before release from the tunnel for radiation levels and removable contamination. Items were decontaminated as necessary. Mining began on the 14 exploratory

drift during this period, and mining support for work related to MINERS IRON continued only as requested.

On 9 December, a reentry team, dressed in full anticontamination clothing and supplied-air equipment, drilled a hole through to the zero point side of the TAPS door. A gas sample, which showed a radiation level of 0.8 mrad/h at contact, 500 ppm of carbon monoxide, and 100 percent of the LEL, was drawn through the drillhole. A valve was installed on this hole, and a ventilation line was hooked up to dissipate the LEL and toxic gas levels. Gas samples taken the next day showed 25 percent of the LEL and 100 ppm of carbon monoxide still existed behind the TAPS.

On 11 December, the hole was checked again and levels had dropped to 10 percent of LEL and 50 ppm of carbon monoxide. At 1000 hours, work began to open the TAPS. All personnel left the area that day by 1530 hours. Work resumed on 15 December, but the TAPS was not opened until 1030 hours on 16 December. Readings at the MAC No. 1 door were 20 percent of the LEL, 30 ppm of carbon dioxide and 0.1 mR/h. The highest radiation reading was 2 mR/h, noted at 20 feet from the zero point side of the TAPS. SNL personnel entered the pipe to survey the MAC. All personnel had exited the pipe by 1430 hours and were surveyed for radioactive contamination. Other entries for surveys by user personnel were conducted by Radsafe personnel as requested.

On 13 January 1981, a team entered the LOS pipe in order to purge the air behind MAC No. 1. Two, one-and-one-eighth inch holes were begun to facilitate this purging. The radiation level at the MAC was 0.3 mrad/h, and 500 ppm of carbon monoxide and 80 to 90 percent of the LEL were noted. The MAC finally was drilled through on 19 January, and 5,000 ppm of carbon monoxide and 75 percent of the LEL were noted through the hole. Control of the tunnel was turned over to DOD the same day, and work began immediately to remove the shield wall at test chamber No. 0 (100 feet into the 11 LOS drift) and portions of the LOS pipe on the portal side of test chamber No. 0. No positive radiation readings were noted from the muck or pipe removed during these operations.

The purge behind the MAC was performed on 21 January. The air coming from behind the MAC showed greater than 100 percent of the LEL and 300 ppm of carbon monoxide. The air was drawn through the ventilation system, filtered, and released outside the tunnel. All personnel left the LOS pipe as air continued to be forced from behind the MAC into the ventilation system. By 1910 hours that day, no trace of any LEL level or any toxic gas could be detected. Work to remove the shield wall continued.

On 23 January, pipefitters began washing down the inside of the LOS pipe around test chamber No. 2 to remove loose contamination in preparation for dismantling and removal of the LOS pipe. This was done in full anticontamination clothing. Contaminated materials were bagged or packaged, as appropriate to prevent spread of contamination, and sent to areas outside the tunnel. All personnel and materials from the area were surveyed at the Radsafe "hot line" set up to monitor and control contamination and neutron-activated materials. Radsafe personnel were given control of access to the LOS pipe and test chambers.

Cleanup and removal of the LOS pipe from MAC No. 1 to the portal side end of the LOS pipe continued from January through June 1981. Miners and pipefitters cutting the pipe wore full-face masks with HEPA filters as well as full anticontamination clothing. The portions of pipe removed were surveyed and swipe samples taken to assure no loose contamination remained on the pipe sections. Pipe sections with no loose contamination but which had been neutron activated at the time of test detonation and so showed above-background radiation levels were marked with "CONTAMINATED MATERIAL" tape for proper handling. Some mining was performed to remove stemming around the LOS pipe near the MAC No. 1; no above-background radiation readings were noted on this muck.

On 29 July, preparations to mill through the MAC No. 1 and 2 were begun. Milling operations began 7 August and continued intermittently through the rest of 1981 and into 1982. No

radiological problems were encountered during these milling operations.

8.4.2 Postevent Mining.

There was no postevent mining to reenter any of the test areas.

8.4.3 Postevent Drilling.

There was no underground or Rainier Mesa postshot drilling to recover zero point core samples for this event.

8.4.4 Industrial Safety.

Checks for the presence of toxic gases and surveys to measure radiation and LEL levels were made on each shift. The results were then recorded in the monitors' logbook.

Appropriate safety measures were taken to protect mining personnel and prevent unsafe conditions. Industrial safety codes including specific codes for mining, tunneling, and drilling, were established by REECO and emphasized during all operations. A written standard operating procedure was required for each operation involving explosives, toxic materials, radioactive material, or any other operation with the potential for personal injury. Each individual involved in such an operation was required to know the contents of the applicable procedures.

The portal construction area and tunnel were mandatory hard hat and foot protection areas (safety shoes, safety boots, DOE-issued miners boots, or toe guards). All personnel on the initial tunnel reentry teams were certified in the use of the Draeger self-contained breathing apparatus and had used the McCaa two-hour breathing apparatus. Standard safety rules and regulations, as spelled out in the "U.S. Bureau of Mines Manual," were observed. HEPA canister filters were supplied routinely for hazardous situations where full-face masks were required. An

array of specialized canister filters could be obtained upon request for special hazardous situations.

All explosives, electro-explosive components, solid propellants, toxic materials, and radioactive materials were handled, stored, and transported in accordance with applicable sections of the following documents:

1. Army Materiel Command Regulations (AMCR 385-224).
2. AEC Manual 0500 Series for the Nevada Test Site.
3. Individual Safe Operating Procedures (by experimenter organization).
4. MINERS IRON Safety Regulations.

All personnel engaged in handling, storing, assembling, or installing explosives, propellants, or electro-explosive devices (or observers of those operations) were required to wear safety glasses or other eye protection which had been approved by the DOD Safety Coordinator.

8.5 RESULTS AND CONCLUSIONS.

Telemetry measurements began at 1000 hours on 31 October and all telemetry stations were secured at 1100 hours on 3 November. Some radioactive debris passed through the LOS containment features and contaminated test chamber experiments, but no release other than inside the LOS pipe occurred.

Initial radiation surveys of the Mesa and portal areas began at 1055 hours on 31 October and were completed by 1141 hours. No radiation above background was detected at the Mesa trailer park area or at the tunnel complex portal.

Reentry into the tunnel began at 0825 hours on 1 November 1980. Initial reentry operations continued over a three-day period. The maximum radiation reading taken during reentry operations was 80 mrad/h, detected at test chamber No. 2 on 1 November. The maximum toxic gas concentration and LEL level encountered during reentry were 5,000 ppm of carbon monoxide and

100 percent of the LEL, measured at a leak in the top of the TAPS on 3 November.

No reentry mining or drilling to recover zero point core samples was conducted for this event.

Personnel exposures received during individual entries to MINERS IRON radex areas from 31 October to 20 November when the use of the Area Access Registers was discontinued, are summarized below. Average exposures are from self-reading pocket dosimeters as recorded on the Area Access Registers. Maximum exposures are from film dosimeter records.

	<u>No. of Entries Logged</u>	<u>Maximum Exposure (mR)</u>	<u>Average Exposure (mR)</u>
All Participants	407	80	2
DOD Participants	54	45	3

SECTION 9

LIST OF REFERENCES

References are not indicated within the text of this report, but are included in this list by chapter or part. Most references are available for review at or through the DOE/NV Coordination and Information Center (CIC). Security-classified references are located at the DNA/HQ Technical Library in Alexandria, Virginia, but are available only to persons with appropriate security clearances and a need for classified information contained in the references.

The CIC is operated by REECo, the custodian of nuclear testing personnel dosimetry and other radiological safety records for DOE/NV, and the custodian for DNA of reference documents for reports on DOD participation in atmospheric, oceanic, and underground nuclear weapons testing events and series. Arrangements may be made to review available references for this report at the CIC by contacting one of the following:

Health Physics and Environmental Division
U.S. Department of Energy
Nevada Operations Office
2753 South Highland Avenue
Post Office Box 98515
Las Vegas, NV 89193-8515

Commercial: (702) 295-0961
FTS: 575-0961

or

Manager, Coordination and Information Center
Reynolds Electrical & Engineering Co., Inc.
Post Office Box 98521 M/S 548
Las Vegas, NV 89193-8521

Commercial: (702) 295-0731
FTS: 575-0731

Major source documents also are available through the National Technical Information Service (NTIS) and may be purchased from NTIS at the address and telephone number listed below:

National Technical Information Service
5285 Port Royal Road
Springfield, VA 22161

Commercial: (703) 487-4650
(Sales Office)

References available through public bookstores and libraries, through the U.S. Government Printing Office, and only at the CIC are listed without asterisks. Asterisks after references or groups of references indicate availability as follows:

- * Available through the NTIS and the CIC.
- ** Located in the REECo Technical Information Office adjacent to the CIC, available through the CIC, and may be subject to Privacy Act restrictions.
- *** Located in the DNA/HQ Technical Library, and subject to security clearance requirements.

PREFACE.

1. Office of Public Affairs, U.S. Department of Energy, Nevada Operations Office, "Announced United States Nuclear Tests," NVO-209 (Rev. 7), January 1987*.
2. Devine, Robert A., Blowing on the Wind: The Nuclear Test Ban Debate, Oxford University Press, NY, 1978.
3. Harris, P.S., et al, Defense Nuclear Agency, OPERATION PLUMBBOB, DNA 6005F, 15 September 1981*.
4. U.S. Senate Committee on Veterans' Affairs, "Veterans' Claims for Disabilities from Nuclear Weapons Testing," U.S. Government Printing Office, Washington DC, 1979.

Section 1, INTRODUCTION

- DOE/NV, "Announced Nuclear Tests," (n. 1).
Devine, "Nuclear Test Ban Debate," (n. 2).
5. Weapons Effects Test Group, Field Command, Defense Atomic Support Agency, "Orientation, Nevada Test Site," January 1962.
 6. Weapons Test Division, Defense Atomic Support Agency, "Orientation, Nevada Test Site," revised 15 August 1964.
 7. Ponton, Jean, et al., Defense Nuclear Agency, Operation DOMINIC II, DNA 6027F, 31 January 1983*.

Section 2, UNDERGROUND TESTING PROCEDURES

8. Liverman, James L., Energy Research & Development Administration, Final Environmental Impact Statement, Nevada Test Site, Nye County, Nevada, ERDA - 1551, September 1977*.
 9. Butkovich, Theodore R., Lawrence Radiation Laboratory, University of California, Effects of Water Saturation on Underground Nuclear Detonations, UCRL-51110, 9 September 1971*.
- Committee on Veterans Affairs, "Claims for Disabilities," (n. 4), on venting.
10. Environmental Sciences Department, Reynolds Electrical & Engineering Co., Inc., "Standard Operating Procedures," January 1976-1980.
 11. Brady, William J., Reynolds Electrical & Engineering Co., Inc., Combination Personnel Dosimeter & Security Credential Holder, NVO-162-27, October 1967.

EVENT SUMMARIES AND EACH EVENT CHAPTER.

12. Energy Research and Development Administration, Nevada Operations Office, NV Completion Report, Operation Anvil, 1 July 1975 through 30 September 1976, NVO-180, April 1977***.
13. Department of Energy, Nevada Operations Office, NV Completion Report, Operation Cresset, 1 October 1977 through 30 September 1978, NVO-201, May 1979***.
14. Department of Energy, Nevada Operations Office, NV Completion Report, Operation Tinderbox, 1 October 1979 through 30 September 1980, NVO-231, June 1981***.
15. Department of Energy, Nevada Operations Office, NV Completion Report, Operation Guardian, 1 October 1980 through 30 September 1981, NVO-237, June 1982***.
16. REECO Environmental Sciences Department field record archives are maintained chronologically and by test event and include the following:
 - a. Procedures, Reentry Plans, Radsafe Plans, and Schedules of Events**.
 - b. Correspondence**.
 - c. Reports, including onsite Radsafe and offsite USEPA event reports**.
 - d. Exposure reports, Radsafe logbooks, Area Access Registers, radiation survey forms, telemetry forms, and other sampling and dosimetry forms**.

APPENDIX A

GLOSSARY OF TERMS

Activity	The rate of decay of radioactive material, usually expressed in disintegrations per minute (dpm)
Access Drift	A passageway tunnel, usually parallel to the LOS drift, also known as the bypass, cable, reentry, or work drift, in which cables from various experiments in the LOS pipe were laid on their way to being connected to the downhole cables in the cable alcove and which was used for access to the main experiment (LOS) drift during construction and recovery phases of a test.
Activation Products	Nuclides made radioactive by neutrons from a nuclear detonation interacting with usually nonradioactive nuclides. Also called "induced activity."
Advisory Panel	A group of experts formed to advise the Test Manager (and later the Test Controller) concerning operational factors affecting a test detonation.
AFSWC	The Air Force Special Weapons Center, located at Kirtland Air Force Base, Albuquerque, New Mexico, provided air support to the AEC Test Manager for NTS testing activities.

GLOSSARY OF TERMS (Continued)

AFSWP	The Armed Forces Special Weapons Project was activated on 1 January 1947, when the AEC was activated, to assume residual functions of the U.S. Army Manhattan Engineer District (see DASA and DNA).
Air Support	This included aircraft, facilities, and personnel required for various support functions during testing, including cloud sampling, cloud tracking, radiation monitoring, photography, and transport of personnel and equipment.
All-Purpose Canisters	Combination canisters made up of a charcoal bed and a HEPA filter.
Alpha Particle	A particle emitted spontaneously from the nucleus of a radionuclide, primarily a heavy radionuclide. The particle is identical to the nucleus of a helium atom, having an atomic mass of four units and an electric charge of two positive units.
Alpine Mining	Mining performed with a mining machine. (This is an alternative to dynamiting for excavation.)
Anticontamination Clothing	Outer clothing worn to prevent contamination of personal clothing, contamination of one's body, and the spread of contamination to uncontrolled areas.
Atmospheric Test Series	This included several series of U.S. tests conducted from 1945 through 1962, when nuclear device detonations and

GLOSSARY OF TERMS (Continued)

experiments were conducted primarily in the atmosphere.

Attenuation

The process by which photons or particles from radionuclides are reduced in number and energy while passing through some medium.

Back

The top (ceiling) of a tunnel.

Background Radiation

There are three meanings for this term, the applicable meaning is determined by the context. The definitions are:

- 1) The radiations of man's natural environment, consisting of cosmic rays and those radiations which come from the naturally radioactive atoms of the earth, including those within one's body.
- 2) A level of radiation (above natural background radiation) that existed in a test area or location prior to a test.
- 3) Radiation levels extraneous to an experiment (the area exposure rate).

Ball Valve

A rotating spool valve designed to close off and provide a gas seal in an LOS pipe in less than one second after detonation. Can be pneumatic, hydraulic, or spring driven.

Beta Particle

A negatively charged particle of very small mass emitted from the nucleus of

GLOSSARY OF TERMS (Continued)

a radionuclide, particularly from fission product radionuclides formed during nuclear detonations. Except for origin, the beta particle is identical to a high speed electron. This may also be a positively charged particle of equal mass called a positron.

Bypass Drift

See Access Drift.

BJY

The intersection of Mercury Highway with roads originally constructed for the BUSTER-JANGLE 1951 atmospheric test series, located at the northwest corner of Area 3 on the NTS. It was previously called the "Y."

Brattice Cloth

Plastic, cheese-cloth reinforced sheeting used to control the spread of contamination.

Bulkhead

This is a wall or embankment constructed in a mine or tunnel to protect against earth slides, fire, water, or gas.

Button-Up Activities

Procedures which consist primarily of completing the stemming; accomplishing the electrical checklist of tunnel portal and trailer park facilities; closing the OBP, gas seal plug, and gas seal door inside the tunnel; clearing the controlled area; and preparing command post and monitoring stations for the actual nuclear detonation.

GLOSSARY OF TERMS (Continued)

Cable Drift	See Access Drift.
Cal-Seal	High-density, quick-drying, high-strength, and resilient commercial sealant.
Cassette	A holder or container for a sample, an experiment, or a group of experiments.
Cellar	The excavated, large-diameter part of a drilled hole over which the drill rig is placed and where valving and other equipment are located.
Chamber	A natural or man-made enclosed space or cavity.
Check Points or Check Stations	Geographic locations established and staffed to control entry into and exit from restricted areas.
Chimney	This refers to the volume of broken rock above an underground cavity formed by a nuclear detonation that falls downward when decreasing cavity gas pressure can no longer support the rocks' weight.
Chromatograph	A piece of equipment used to separate and analyze mixtures of chemical substances by chromatographic absorption.
Cloud Sampling	The process of collecting particulate and gaseous samples from an effluent cloud to determine the amount of total airborne radioactivity and specific radionuclides in the cloud for sub-

GLOSSARY OF TERMS (Continued)

sequent analysis of detonation characteristics. This type of sampling usually was accomplished by specially equipped aircraft.

Cloud Tracking

The process of monitoring and determining the drift and movement of an effluent cloud, usually performed by radiation monitoring and visual sighting from aircraft.

Collar

See "Shaft Collar"

Console

A cabinet or panel containing instrumentation for monitoring or controlling electronic or mechanical testing devices.

Construction Station

The distance in feet along the tunnel from the portal or a particular junction, usually expressed in hundreds of feet plus remaining whole feet. Construction station 350 is expressed as CS 3+50.

Containment

The act of preventing release of any radioactive effluent into the atmosphere or parts of a tunnel complex beyond the stemming and other containment features. It is used in reference to the stemming, TAPS, OBP, or the gas seal plug. An event is said to have been "contained" if no effluent is released to the atmosphere or if no radioactive material is released beyond the stemmed portion of the tunnel.

GLOSSARY OF TERMS (Continued)

Containment Assessment Drift	Another name for an access or re-entry drift.
Contamination	<p>This is defined in two ways as follows:</p> <ol style="list-style-type: none">1) The term may refer to the presence of fixed or removable radioactive material in a location. This is usually caused by the spread of fission and activation products of a nuclear detonation or fissionable material from a device incorporated with particles of dust or device debris.2) The term may also refer to the depositing on, or spreading of, radioactive materials to undesirable locations, personnel, structures, equipment, or other surfaces outside a controlled area.
Crater	This is the depression formed on the earth's surface by a near-surface, surface, or underground detonation. Crater formation can occur by the scouring effect of airblast, throw-out of broken surface material, or surface subsidence resulting from underground cavity formation and subsequent rock fall, or chimneying, to the surface.
Crater Experiment	A test designed to breach and excavate the ground surface, thereby forming an ejecta crater (as opposed to a sink or subsidence crater).

GLOSSARY OF TERMS (Continued)

DAC	The DNA Auxiliary Closure (DAC) is a closing system found in the LOS pipe which closes milliseconds after device detonation.
Dance Hall	A large alcove used for data recording equipment.
DASA	AFSWP became the Defense Atomic Support Agency (DASA) in 1959. See AFSWP and DNA.
D-day	The term used to designate the day on which a test takes place.
D+1	The first day after a test event. D+2 is the second day after detonation, D+3 is the third day, etc.
Decontamination	The reduction or removal of contaminating radioactive material from a structure, area, object, or person. Decontamination may be accomplished by (1) treating the surface to remove or decrease the contamination, (2) letting the material stand so that the radioactivity is decreased as a result of natural decay, or (3) fixing and covering the contamination to attenuate the radiation emitted.
Device	This is comprised of nuclear fission (or fission and fusion) materials together with arming, fusing, firing, high-explosive, canister, and diagnostic measurement equipment that have not

GLOSSARY OF TERMS (Continued)

	been configured into an operational weapon.
DNA	An acronym for the Defense Nuclear Agency, successor to DASA in 1971.
DOD	An acronym for the U.S. Department of Defense, the federal executive agency responsible for the defense of the United States. Included in this group are the military services and special joint defense agencies.
Dose	The quantity (measured or accumulated) of ionizing radiation energy absorbed into the medium it passes through. In a person, dose is measured in rems or rads.
Dose Rate	The amount of ionizing radiation energy that an individual or material could absorb per unit of time. Dose rates are usually expressed as rad or rem per hour. Subdivisions of a rad or rem also are used, e.g., mrem/h means millirem per hour. (A millirem equals one thousandth of a rem).
Dosimeter	A device used to measure radiation doses. Devices worn or carried by individuals are called personnel dosimeters.
dpm	This stands for disintegrations per minute, which is a measure of the activity of material.

GLOSSARY OF TERMS (Continued)

Draeger Breathing Apparatus	See Scott-Draeger.
Draeger Multi-Gas Detector	An instrument used to detect toxic gases. A sample of the ambient atmosphere is drawn through a selected chemical reagent tube which indicates the concentration of a particular toxic gas.
Dressed Out	This means one is dressed in anticon-tamination clothing and any necessary associated equipment.
Drift	A horizontal or inclined passageway excavated underground with one access opening. It is used interchangeably with the term "tunnel" at the NTS.
Drill Hole Designations	These are defined as follows: From the surface - PS-1V: Post-shot drill hole number 1 - vertical PS-1D: Post-shot drill hole number 1 - directional PS-1A: Post-shot drill hole number 1 - angle Each 'S' added after any of the above notations indicates a "sidetrack" or change of direction in the drill hole.

GLOSSARY OF TERMS (Continued)

- From underground locations - sample recovery core holes are referred to as RE (Reentry) No. 1, RE No. 2, etc. ("DNRE" means the reentry hole was DNA requested.)
- Dry Run A simulation of the functions occurring in the minutes before, during, and after the event. All timing and firing signals are sent in the proper sequence from the Control Room at CP-1. Each run begins with the first required timing and firing signal (normally minus 15 minutes) and ends with the firing signal. The audio countdown is transmitted over Net 1 (DNA) and on other nets as agreed upon with appropriate agencies. There are various types of dry runs depending on the degree of participation required of the agencies involved.
- Dutchman Part of the tunnel ventilation system. It is a small-diameter filler piece used to close the gap between two lengths of ventilation tubing.
- Effects Experiments These are experiments with the purpose of studying the effects of a nuclear detonation environment on materials, structures, equipment, and systems. They include measurements of the changes in the environment caused by the nuclear detonation, such as ground movement, air pressures (blast), thermal radiation, nuclear radiation, and cratering.

GLOSSARY OF TERMS (Continued)

Exoatmospheric	This refers to the area outside the gaseous mass which envelopes the earth.
Explosimeter	A battery-operated detector calibrated to indicate the concentration in the ambient atmosphere of explosive gases and vapors as percent of the lower explosive limit (LEL) of methane gas (5 percent concentration in air).
Exposure	A measure, expressed in roentgens (R), of the ionization produced by gamma or x rays in air. [This may also be represented by subdivisions of R; e.g., 1/1000 R = 1 milliroentgen (mR).]
Exposure Rate	The exposure rate is the radiation exposure per unit of time, usually per hour, but it may be stated in smaller or larger units (e.g., R/min, mR/h, R/day).
Face	This is the front end of a tunnel or other excavation that is being worked to advance the tunnel.
FDR	A successful final dry run (FDR) is the last dry run before a test is detonated.
Film Badge	A dosimeter used for the indirect measurement of exposure to ionizing radiation. It generally contains two or three films of differing sensitivity. Films are wrapped in paper or other thin material that blocks light

GLOSSARY OF TERMS (Continued)

but is readily penetrated by radiations or secondary charged particles resulting from the radiations to be measured. Film packets generally have at least one metal filter or may be in holders with multiple filters. After being worn as a film badge or film dosimeter. Films are developed and the degree of darkening (or optical density) measured indicates the radiation exposure. Film dosimeters commonly are used to indicate gamma and x-ray exposures, and also can be designed to determine beta and neutron doses.

Fission

The process whereby the nucleus of a particular heavy element splits into (generally) two nuclei of lighter elements, with an accompanying release of energy. The most important fissionable, or fissile, materials are uranium-235 and plutonium-239. Fission is caused by the absorption of a neutron in a nucleus.

Fission Products

A general term used for the complex mixture of radioactive nuclides (see Radionuclides) produced as a result of nuclear fission.

Fissionable Material

A synonym for fissile material, also extended to include material that can be fissioned by fast neutrons only, such as uranium-238. Used in reactor operations to mean reactor fuel.

GLOSSARY OF TERMS (Continued)

- Flex Line** A temporary flexible plastic tubing used to ventilate areas in which the main ventilation system did not provide adequate circulation of the air.
- Forward Control Point** A geographic location in the forward test area, usually adjacent to the closed (or secured) test area.
- Full Power Full Frequency (FPFF) Dry Run** This is similar in intent to a mandatory full participation dry run. The FPFF is sometimes combined with the hot dry run (HDR). This run is optional with the device engineer. When conducted, the LOS pipe is under vacuum, telephones and intercoms are disconnected, and tunnel utility and instrumentation power are operated in event-day configuration. Also all instrumentation is hooked up and operated in event-day configuration (simulators are not used).
- Fusion** The combination of two very light nuclei (of atoms) to form a relatively heavier nucleus, with an accompanying release of energy is called fusion. (It is also known as thermonuclear fusion).
- Gamma Photons** Electromagnetic radiations of high energy that are emitted from the nuclei of radionuclides. These photons are sometimes referred to as bundles of energy, and usually accompany other nuclear reactions, such as fission, neutron capture, and beta particle

GLOSSARY OF TERMS (Continued)

emission. Gamma photons, or rays, are identical with x rays of the same energy, except that x rays result from orbital electron reactions rather than being produced in the nucleus.

Gamma Shine

This occurs when a measurable gamma radiation intensity from an approaching radioactive cloud or passing cloud is noted, as opposed to measurements from or in gamma emitting fallout. This also includes gamma radiation scattered by air molecules, as opposed to direct radiation from a gamma source.

Gas Seal Door

A steel door on the portal side of the gas seal plug. It is closed during button up with about a 10 psi gas pressure applied between the gas seal plug and the gas seal door as an additional reassurance against low-pressure leaks.

Gas Seal Plug

This is one containment feature within the tunnel complex; generally it is designed for 500°F and 500 psi. The gas seal plug is sometimes referenced as the "hasty plug." This plug is similar to a lower pressure overburden plug, but is placed closer to the portal and seals off the entire tunnel complex from the portal.

Gate 300

Refers to the permanent security station set up in Area 6 near the Control Point facilities at which reentry and recovery personnel wait during execution of an event. After

GLOSSARY OF TERMS (Continued)

reentry parties were released from this gate, they moved to the FCP and again awaited release.

- Geiger-Mueller Counter An instrument consisting of a Geiger-Mueller tube and associated electronic equipment used to detect, display, and sometimes record nuclear radiation levels.
- Geophone An instrument used to detect vibrations in rock or soil. At NTS, it is used remotely to detect rock falls, earth movement, and cavity collapse underground while providing audible signal and visual display data.
- Ground Zero A term used during atmospheric testing to denote a point on the surface of the ground directly below or coinciding with an atmospheric detonation (see surface ground zero and zero point).
- Heading The furthest point one can walk into a drift or tunnel.
- High-Efficiency
Particulate Canisters Canisters used with a face mask to filter particulate vapors out of breathing air. These canisters were called "absolute" filters because they filtered 99.97% of particulate matter greater than 0.3 micrometers in size. These were later referred to as HEPA filters (high-efficiency particulate aerosol).

GLOSSARY OF TERMS (Continued)

H-hour	"Time zero" or the exact time of detonation to the minute, second, or fraction of a second; as opposed to H + 1 which implies one hour after detonation (unless otherwise noted in seconds or minutes).
Horizontal Line-of-Sight (HLOS)	A general term used to refer to a family of events conducted in a horizontal tunnel. The term was sometimes used to refer to the pipe and vacuum system for some events.
Hot Line	A location on the edge of a radex area where personnel exiting remove anticon-tamination clothing and equipment, and monitoring for contamination and de-contamination is performed as necessary. This term also was used to denote the centerline of a fallout pattern.
Invert	The bottom (floor) of a tunnel.
Ion	An atomic particle or part of a mole-cule bearing an electric charge. Usually a positively charged ion and a negatively charged ion are formed as a pair (e.g., a negatively charged elec-tron is displaced from an atom so the remaining atom is positively charged).
Ionizing Radiation	This includes any particulate or electromagnetic radiation capable of producing ions, directly or indirectly, in its passage through air or matter. Alpha and beta particles produce ion

GLOSSARY OF TERMS (Continued)

pairs directly, while the electrons of initial ion pairs produced by gamma and x rays in turn produce secondary ionization in their paths. Neutrons may displace a positively charged part of a nucleus, such as a proton or alpha particle which produces secondary ionization.

Isotopes

This refers to different types of atoms within the same element, all reacting approximately the same chemically, but differing in atomic weight and nuclear stability. For example, the element hydrogen has three isotopes; normal hydrogen (the most abundant) heavy hydrogen (called deuterium), and radioactive hydrogen (called tritium).

Keyed Concrete Plug

This refers to a concrete plug placed in an excavated area of greater diameter than the shaft or tunnel cross section such that the concrete is poured into the surrounding rock, thus providing greater strength against overpressure from the nuclear detonation.

LEL

The lower explosive limit refers to a mixture of explosive gases and air that is at the minimum concentration necessary to cause an explosion if ignited. The MSA explosimeter is used to determine percentages of the LEL, and is calibrated with a 5% methane gas and air mixture. A minimum explosive mixture is 100% of the LEL.

GLOSSARY OF TERMS (Continued)

Leukemia Cluster	An apparent but unexpected or extraordinary group of leukemia cases within some number or group of persons.
Long Line	Gas sampling line into the LOS drift which does not connect to the LOS pipe.
LOS Pipe	An evacuated pipe that extends from the device to the test chambers. It may be either horizontal or vertical, and in it are experiment protection devices and hardware.
Mandatory Full Participation (MFP) Dry Run	This is a dry run peculiar to DOD events. Its purpose is threefold: first, to check all experiments with the event site electrical system in its shot configuration; second, to check for cross-talk between experiments; and third, to operate all recording, timing, and monitoring equipment as closely to shot configuration as is possible. The pipe is under vacuum and the tunnel and portal instrumentation trailers are cleared of personnel. After a successful MFP dry run, all interconnections necessary to place experiments into shot configuration from the MFP configuration are made. Timing, firing, and monitoring system junction boxes are locked and no changes are made except with the express approval of device systems personnel and the Technical Director.

GLOSSARY OF TERMS (Continued)

Manhattan Engineer District	The U.S. Army predecessor organization to the U.S. Atomic Energy Commission and the Armed Forces Special Weapons Project.
Manned Stations	These are locations inside the closed and secured area which are occupied by authorized personnel during an event.
Manway	A crawl space or other passageway through the gas seal plug, the overburden plug, and other structures.
McCaa Two-Hour Breathing Apparatus	A self-contained respiratory device that supplies two hours of breathing oxygen.
MFP	See Mandatory Full Participation Dry Run
mR	This stands for milliroentgens, a radiation exposure term meaning a thousandth of a roentgen (R). (Also, see Exposure.)
mrads/h	A radiation intensity term used to show that both gamma and beta levels were being measured.
Mucking	This refers to the removal of loose rock from drilling and mining operations.
Noble Gases	Those inert gases which do not react with other elements at normal temperature and pressure (i.e., helium, neon,

GLOSSARY OF TERMS (Continued)

- argon, krypton, xenon, and sometimes radon).
- Nuclear Device**
(vs. weapon or bomb)
- This refers to a device in which most of the energy released in a detonation results from reactions of atomic nuclei, either fission, or fission and fusion. A device under development (see Device) is not considered a weapon or bomb. Both A- (or atomic) bombs and H- (or hydrogen) bombs could be called atomic weapons because both involve reactions of atomic nuclei. However, it has become customary to call weapons A-bombs if the energy comes from fission, and H-bombs if most of the energy comes from fusion (of the isotopes of hydrogen or other light nuclides - see definition). A developmental nuclear device is not a weapon or weapon component until it can be mated to a delivery system.
- Nuclear Device Tests**
- Tests carried out to supply information required for the design, improvement, or safety aspects of nuclear weapons, and to study the phenomena and effects associated with nuclear explosions.
- Nuclear Weapon Tests**
- Tests that provide development and weapons effects information, and may or may not utilize a deliverable nuclear weapon.
- OAP/R Canister**
- A canister used with a face mask to filter out organics, acids, particu-

GLOSSARY OF TERMS (Continued)

lates, and radioactive material from breathed air.

Offsite

Radiation detected offsite is radioactivity occurring outside the Test Range Complex, an area that includes both the Nevada Test Site and the adjacent Nellis Air Force Range.

Onsite

A notation that radioactivity was detected onsite only is made for tests from which there was an unplanned release of radioactivity into the atmosphere that was not detectable beyond the boundaries of the Test Range Complex.

Overburden

As used in connection with NTS tunnels, this is the consolidated and unconsolidated rock above a tunnel vertically to the surface; thus, it is the burden of rock over a tunnel.

Overburden Plug (OBP)

A containment feature within the tunnel complex. It is now a high-strength concrete plug keyed into the tunnel rock near the test location and is generally designed to withstand 1000°F and 1000 psi. It originally was named because it was constructed to represent the same containment strength as the rock above the tunnel, or overburden.

Party Monitors

Radiation (Radsafe) monitors assigned to reentry and recovery parties or groups.

GLOSSARY OF TERMS (Continued)

Privacy Act	The Privacy Act of 1974 is part of Public Law 93-579. This was an Act to amend Title 5, U.S. Code, by adding Section 552a, which was to safeguard individual privacy from the misuse of federal agency records, to provide that individuals be granted access to records concerning them which are maintained by federal agencies, to establish a Privacy Protection Study Commission, and for other purposes.
ppm	The term parts per million is used when determining concentrations of toxic gases or other materials. It refers to either relative weight, such as micrograms of a material per gram of medium, or relative volume, such as cubic centimeters or milliliters per cubic meter.
rad	An acronym for "radiation absorbed dose," a unit of an absorbed dose of ionizing radiation. A dose of one rad means the absorption of 100 ergs of energy from ionizing radiation per gram of absorbing material (e.g., body tissue).
Radex Area	A radiation exclusion (radex) area is any area which is controlled for the purpose of protecting individuals from exposure to radiation and/or radioactive material.
Radiation Exposure	Exposure to radiation may be described by a number of terms. The type of radiation one is exposed to is important

GLOSSARY OF TERMS (Continued)

in establishing doses. External exposure can be from beta particles, neutrons, gamma and x rays; internal exposure is received from radionuclides deposited within the body which may emit alpha, beta, gamma, or x radiation and irradiate various body organs. (see Dose and Exposure).

Radioactive Effluent	This includes the radioactive material, steam, smoke, dust, and other particulate debris released to the atmosphere from an underground nuclear detonation.
Radioactive or Fission Products	A general term for the complex mixture of radionuclides produced as a result of nuclear fission (see Activation Products).
Radionuclides	A collective term for all types of radioactive atoms of a given element, as opposed to that element's stable nuclides (see Isotopes).
Recovery Operations	The process of finding and removing experiments, by-products, or data from the test area after a test event.
Red Shack	An underground (usually) intermediate point provided for the device laboratory's use in checking out and exercising the arming and firing system.
Reentry Drift	See Access Drift.

GLOSSARY OF TERMS (Continued)

Sandbag Plugs	Barriers used in tunnels, constructed of sandbags, to help contain underground detonations and minimize damage to underground workings.
Sandia Auxiliary Closure (SAC)	A device used to seal an HLOS pipe after a nuclear detonation.
Scatterer Station	A point along an LOS pipe where the radiation flux is deflected into an area off the LOS pipe as required for the testing or exposure of scatterer area experiments.
Scientific Station	The distance in feet along the HLOS pipe measured from the zero point. These distances are generally expressed in hundreds of feet plus whole numbers or to the nearest complete hundredths of feet (if fractional). Scientific Station 650 is expressed as SS 6+50; Scientific Station 390.65 is expressed as SS 3+90.65.
Scott-Draeger Self-contained Breathing Apparatus	This includes a self-contained recirculating unit, complete with "full view" facepiece, compressed oxygen cylinder, breathing bag, carbon dioxide absorber, and pressure demand regulator. It is used when an extended exposure to an extremely hazardous or oxygen deficient atmosphere, or both, is required. This unit is capable of sustaining the wearer, under normal usage, for four to four and one-half hours; however, pertinent approved schedules limit NTS use to two hours.

GLOSSARY OF TERMS (Continued)

Seismic Motion	Earth movement caused by an underground nuclear detonation, similar to that of a minor earthquake.
Shaft	A long narrow passage sunk into the earth, usually vertically, but inclined for some mining operations. Shafts for device emplacement, ventilation, or access to underground workings may be drilled or mined.
Shaft Collar	The area immediately around a shaft at ground level, usually cemented, which supports the headframe and other equipment.
Shielding Walls	These are walls or barriers used to protect equipment or instrumentation from heat, blast, and radioactivity.
Slushing Operations	The process of moving broken rock with a scraper or scraper bucket. May be used on the surface or underground, where ore or waste rock is slushed into hoppers or other locations for removal.
Spalling	Rock disintegration evidenced by flaking, chipping, peeling, or loosening of layers on the outside edges. It may be caused immediately after detonation by rock stressing to rock near the detonation point. It also may result later, after continued stressing from temperature change expansion and contraction. Spalling also may result or begin when rock containing moisture is

GLOSSARY OF TERMS (Continued)

raised to a high temperature and expanding vapor creates fractures.

Stemming

The various materials used to back-fill or plug the emplacement shaft, drift, or LOS drift to contain overpressure and radioactive material from a nuclear detonation.

Stubs

This refers to a variable number of smaller diameter LOS pipes which protrude from the portal side end of the main LOS pipe and contain experiments to be exposed to the radiation flux during event execution.

Surface Ground Zero

The location on the ground surface directly above an underground zero point (see ground zero and zero point).

Survey

In the tunnels, a survey might include taking radiation readings with a portable instrument, checking for the presence of an explosive mixture with an MSA explosimeter or GPK, determining toxic gas levels with Draeger tubes, and/or checks for tunnel hazard and damage (also called a "walk-through" or "walk-out"). Radsafe personnel made the radiation surveys, Radsafe or industrial hygiene personnel (both in the REECo Environmental Sciences Department) checked for toxic gases and the LEL level, and tunnel mining and construction personnel performed walk-throughs usually accompanied by Radsafe

GLOSSARY OF TERMS (Continued)

and/or industrial hygiene support (see tunnel walk-out).

TAPS

The tunnel and pipe seal is an experiment protection feature along the LOS pipe which allows the experiments to be exposed to the desired levels of radiation while being protected from debris. It contains a massive steel door which closes after ground shock passes to form a 1000°F and 1000 psi seal. The TAPS also includes the high-strength concrete plug which surrounds the metallic shroud of the door.

Test Chamber

A section of the LOS pipe in which experiments are placed. It may or may not be enlarged, depending upon the test design.

Test Controller

This person was a DOE official designated by the Manager, Nevada Operations Office, to assume responsibility for the field operations involved in conducting a nuclear test at the Nevada Test Site.

Test Event

This includes the preparations, including arming and firing, and the actual testing of a nuclear device, including detonation, concurrent measurements and effects, and later measurements and studies.

GLOSSARY OF TERMS (Continued)

Testing Organizations	Organizations conducting nuclear tests at the NTS (see DOD, DNA, LASL, LLL, and SLA).
Tonopah Test Range	The TTR is located in the northwest corner of Nellis Air Force Range near Tonopah, Nevada.
Trailer Park	Areas near a tunnel portal or on the Mesa where instrumentation or instrumentation support trailers are parked.
Tunnel	At NTS, this refers to a horizontal underground excavation driven on a predetermined line and grade to some specific target.
Tunnel Access	This refers to entering to a tunnel or tunnel complex upon approval of the Test Director during test operations, or upon approval of the Tunnel Superintendent during routine operations.
Tunnel Complex	This includes the complete set of drifts and support equipment comprising one tunnel test area.
Tunnel Walk-Out	A visual, walking inspection of the tunnel or tunnel complex, usually performed as a part of the initial reentry after a detonation, to check for damage and hazards prior to allowing general access to the underground workings.
Type N Canisters	These canisters are used with face masks to filter out carbon monoxide.

GLOSSARY OF TERMS (Continued)

Underground Structures Program	This refers to the construction and fabrication of test structures underground for the purpose of detonation effects evaluation.
User	Any organization conducting tests at the NTS (See Testing Organizations).
Vela Uniform Project	A Department of Defense (DOD) program designed to improve the capability to detect, identify, and locate underground nuclear explosions.
Venting	A dynamic release of radioactive material, steam, smoke, dust and other particulate debris through a zone of weakness from the detonation-formed cavity into the atmosphere.
Weapons Effects Experiments	Experiments with the purpose of studying the effects of a nuclear detonation environment on materials, structures, equipment, and systems. They include measurements of the changes in the environment caused by the nuclear detonation such as ground movement, air pressures (blast), thermal radiation, nuclear radiation, and cratering.
Weather Briefings	These are a part of the readiness briefings, which are meetings of test-associated administrators, advisors, and other technical personnel prior to each test event to evaluate weather conditions and forecasts on event day,

GLOSSARY OF TERMS (Continued)

and make decisions on any necessary operational schedule changes.

Work Drift

See Access Drift.

Workings

This refers to an excavation or group of excavations made in mining, quarrying, or tunneling. It is used chiefly in the plural, such as "the workings extended for miles underground."

x rays

Electromagnetic radiations produced by electron reactions, as opposed to emission of gamma photons given off by nuclei. Otherwise, high energy x rays are identical with gamma photons of the same energy.

Yield

The total effective energy released by a nuclear detonation. It is usually expressed in terms of the equivalent tonnage of TNT required to produce the same energy release in an explosion. The total energy yield is manifested as nuclear radiation (including residual radiation), thermal radiation, and blast and shock energy; the actual distribution depending on the medium in which the explosion occurs and the type of weapon.

Zero Point

At the instant of detonation, this is the center of an underground explosion of a nuclear device or weapon.

APPENDIX B

ABBREVIATIONS AND ACRONYMS

The abbreviations and acronyms in the following list are used in this sixth volume of DOD underground testing reports. Additional information and definitions may be found in the text and in the Glossary of Terms.

AA	Agbabian Association
AEC	Atomic Energy Commission
Aerojet	Aerojet General Corporation
AES	Auxiliary Experiment Station
AFSWC	Air Force Special Weapons Center
AFSWP	Armed Forces Special Weapons Project
AFWL	Air Force Weapons Laboratory
ALOO	Albuquerque Operations Office
AMC	Army Materiel Command
ASN	Air Surveillance Network
ASR	Alcove splice rack
AVCO	AVCO Corporation
AWRE	Atomic Weapons Research Establishment
BAC	Boeing Aircraft Corporation
Bkg	Background radiation measurement
BJY	BUSTER-JANGLE roads intersection with the Mercury Highway
BMO	Ballistic Missile Office
CAPco	Corrales Applied Physics Company
CASES	Merritt Cases, Inc.
CC	Crosscut
CCTV	Closed-circuit television
CDC	Centers for Disease Control (formerly the Center for Disease Control)
CEP	Containment Evaluation Panel
CIC	Coordination and Information Center
CP	Control Point
CP-1	Control Point Building 1
CP-2	Control Point Building 2
CTO	Continental Test Organization
D-day	The day a nuclear detonation takes place
DAC	DNA Auxiliary Closure
DASA	Defense Atomic Support Agency
DMA	Division of Military Application
DNA	Defense Nuclear Agency
DNRE	DNA Reentry
DPP	Drift Protection Plug
DOD	Department of Defense
DOE	Department of Energy
dpm	Disintegrations per minute
Draper	C. S. Draper Laboratory
EDAC	Engineering Decision Analysis Company

ABBREVIATIONS AND ACRONYMS (Continued)

EMP Electromagnetic pulse
 EG&G EG&G, Inc. (formerly Edgerton, Germeshausen, & Grier)
 EPA Environmental Protection Agency
 ERDA Energy Research and Development Administration
 ES Experiment Station
 ETI Effects Technology, Incorporated
 FAC Fast Auxiliary Closure
 FCDASA Field Command, Defense Atomic Support Agency
 FCDNA Field Command, Defense Nuclear Agency
 FCP Forward Control Point
 FCTC Field Command, Test Construction (Division of Test Directorate)
 FCTMC Field Command, Test Management, Construction
 FCTMD Field Command, Test Management, Test Director
 FCTME Field Command, Test Management, Engineering
 FDR Final dry run
 FPFF Full-power full-frequency (dry run)
 F&S Fenix & Scisson, Inc.
 ESD Environmental Sciences Department, REECo
 GE General Electric Corporation
 GM Geiger-Mueller
 GSAC Gas Seal Auxiliary Closure
 GZ Ground zero
 HDL Harry Diamond Laboratories
 HDR Hot dry run
 HE High explosives (conventional)
 HEPA High-efficiency particulate aerosol
 HFR High Fluence Recoverable
 H&N Holmes & Narver, Inc.
 HLOS Horizontal line-of-sight
 HAC Hughes Aircraft Co.
 IRT Intelcom Rad Tech
 ISAFAF Indian Springs Air Force Auxiliary Field (formerly ISAFB)
 JAYCOR Jaycor Corporation (derived from J. A. Young Corporation)
 ISAFB Indian Springs Air Force Base
 JCS Joint Chiefs of Staff
 KAFB Kirtland Air Force Base
 KOA Ken O'Brien Associates
 KN Kaman Nuclear
 KSC Kaman Sciences Corp. (formerly Kaman Nuclear)
 kt Kilotons
 LANL Los Alamos National Laboratory
 LASL Los Alamos Scientific Laboratory (now Los Alamos National Laboratory)
 LEL Lower explosive limit
 LLL Lawrence Livermore Laboratory (formerly LRL)
 LLNL Lawrence Livermore National Laboratory
 LMSC Lockheed Missile and Space Corporation
 LOS Line-of-sight
 LPARL Lockheed Palo Alto Research Laboratory
 LRL Lawrence Radiation Laboratory (now Lawrence Livermore National Laboratory)
 LVFO Las Vegas Field Office
 M&D MAC and DAC
 MAC Mechanical Auxiliary Closure
 MDAC McDonald-Douglas Aircraft

ABBREVIATIONS AND ACRONYMS (Continued)

MDR	Mandatory dry run
MED	Manhattan Engineer District
MFP	Mandatory full-participation (dry run)
MPC	Maximum permissible concentration
mrad	Millirad
mrem/qt	Millirem per quarter
mrem/yr	Millirem per year
mR/h	Milliroentgens per hour
MRC	Mission Research Corporation
MSA	Mine Safety Appliance
MSD	Mandatory Signal Dry Run
MSL	Mean sea level
NO ₂	Nitrogen dioxide
NO+NO ₂	Nitric oxide plus nitrogen dioxide
NPG	Nevada Proving Ground
NRDS	Nuclear Rocket Development Station
NTIS	National Technical Information Service
NTS	Nevada Test Site
NTSO	Nevada Test Site Organization
NV	DOE Nevada Operations Office
OBP	Overburden plug
Pan Am	Pan American World Airways
PDT	Pacific Daylight Time
PI	Physics International
ppm	Parts per million
psi	Pounds per square inch
PST	Pacific Standard Time
QF	Quality factor
Radex Area	Radiation exclusion area
rad	Radiation absorbed dose
rad/h	Radiation absorbed dose per hour
Radsafe	Environmental Sciences Department (formerly Radiological Safety Department), REECo
radSAFE	Radiological safety, in general
RAMS	Remote area monitoring system
RCG	Radioactivity concentration guide
REECO	Reynolds Electrical & Engineering Company, Incorporated
rem	Roentgen equivalent man or mammal
R/h	Roentgens per hour
ROSES	Recorder and Oscilloscope Sealed Environmental System
RPG	Radiation protection guide
SAC	Sandia Auxiliary Closure
SAI	Science Applications, Inc. (now Science Applications International Corp., SAIC)
SAMSO	Space and Missile Systems Organization
SC	Sandia Corporation (now Sandia National Laboratories)
SCBA	Self-contained breathing apparatus
SDR	Signal dry run
SGZ	Surface ground zero
SFOO	Santa Fe Operations Office
SLA	Sandia Laboratories, Albuquerque (now Sandia National Laboratories)
SNL	Sandia National Laboratories
SOP	Standard operating procedures
SRD	Secret Restricted Data
SRI	Stanford Research Institute

ABBREVIATIONS AND ACRONYMS (Concluded)

SSPO	Navy Strategic Systems Project Office
SSS	Systems, Science, and Software
STU	Special Test Unit
TAPS	Tunnel and Pipe Seal
TC	Test chamber
TCDASA	Test Command, Defense Atomic Support Agency
TEP	Test Evaluation Panel
TGD	Test Group Director
TGS	Test Group Staff
TNT	High explosive chemical (trinitrotoluene)
TLD	Thermoluminescent dosimeter
TRI	Technical Representatives, Incorporated
TRW	Thompson, Ramo and Woolridge, Incorporated
TTR	Tonopah Test Range
UCRL	University of California Radiation Laboratory (now Lawrence Livermore National Laboratory)
USAF	United States Air Force
USGS	United States Geological Survey
VA	Veterans Administration
VLOS	Vertical line-of-sight
WETG	Weapons Effects Test Group
WES	Waterways Experiment Station
WSI	Wackenhut Services, Incorporated
WTD	Weapons Test Division

APPENDIX C

GENERAL TUNNEL REENTRY PROCEDURES FOR
DEPARTMENT OF DEFENSE AND SANDIA LABORATORY TESTS

SLA-74-0199
Specified External Distribution Only
Printed May 1974

GENERAL TUNNEL REENTRY PROCEDURES FOR DEFENSE NUCLEAR AGENCY
AND SANDIA LABORATORIES NUCLEAR TESTS

J. H. Metcalf
Instrumentation, Dosimetry and NTS Projects Division, 3313
Sandia Laboratories, Albuquerque, New Mexico 87115

ABSTRACT

Underground weapons effects testing requires that personnel reenter the tunnel complex to recover data and scientific experiments for postshot evaluation. The preparation for and the handling of the hazards encountered during such reentry operations are described.

Issued by Sandia Laboratories, operated for the United States Atomic Energy Commission by Sandia Corporation

NOTICE

This report was prepared as an account of work sponsored by the United States Government. Neither the United States nor the United States Atomic Energy Commission, nor any of their employees, nor any of their contractors, subcontractors, or their employees, makes any warranty, express or implied, or assumes any legal liability or responsibility for the accuracy, completeness or usefulness of any information, apparatus, product or process disclosed, or represents that its use would not infringe privately owned rights.

SF 1004-DF (2-74)

TABLE OF CONTENTS

	<u>Page</u>
Introduction	5
Responsibilities	5
Manager, NVOO	5
Test Controller	5
Test Group Director	5
SLA Environmental Health Department	6
NTS Support Contractor	6
Preshot Preparations for Reentry	6
Containment	6
Ventilation System	6
Environmental Instrumentation	6
Gas Sampling System	7
Reentry Communications System	7
Possible Hazards to Reentry Personnel	7
Radiation	7
Explosive and Toxic Gases	7
Tunnel Damage	8
Explosives	8
Toxic Materials	8
High-Pressure Gas Cylinders	8
Reentry Party Composition and Equipment	8
Guidelines for Initial Reentry Parties	10
Authorities	10
Activating & Monitoring Tunnel Ventilation System	10
Reentry Control Group	10
Team Limitations	10
Self-Contained Breathing Apparatus	10
Emergency Return to Portal	11
Rescue Team	11
Medical Support	11
Summary of Initial Tunnel Reentries	11
Preparation of Tunnel for Reentry	11
Evaluation of Tunnel Environment	12
Exploration of Tunnel	12

TABLE OF CONTENTS (cont.)

	<u>Page</u>
Scientific Assessment of the Experiments	13
Scientific Assessment Team	13
Photographic Documentation	13
Removal of Unexpended Explosives	13
Recovery of Experiments From the Test Chambers	13

GENERAL TUNNEL REENTRY PROCEDURES FOR DEFENSE NUCLEAR AGENCY
AND SANDIA LABORATORIES NUCLEAR TESTS

Introduction

Detonation of a nuclear device in an underground test facility adds many unique hazards to those existing in any underground construction. Instrumentation which can be remotely monitored can provide a general picture of conditions, but ultimately, personnel, properly protected from the hazards they might encounter, must reenter the tunnel to verify the condition of the facility.

Personnel from the Environmental Health Department of Sandia Laboratories have been participating in tunnel reentries since 1962. During this time experience, improvements in instrumentation, and changes in containment features have caused tunnel reentry procedures to be continually revised. This document preshot preparations and postshot procedures currently being used for safe and economical reentry and scientific recovery from a tunnel area.

Responsibilities

Manager, NVOO

The Manager, NVOO, is responsible for administering, preparing, and executing all programs and projects at NTS. He has the overall responsibility for the health and safety of both the general public and NTS personnel for all activities at the NTS. The Manager, NVOO, may delegate operational control of an approved program, project, or experiment to a Test Controller, who is responsible for field execution of that specific program.

Test Controller

The Test Controller has full responsibility during the test execution period for the safe conduct of the program to which he is assigned. by mutual agreement between the Test Controller and a scientific user, control of safety hazards within the area assigned for a particular activity may be delegated to the user's Test Group Director during times other than the test execution period.

Test Group Director

Whenever operational control is delegated to a Test Group Director, he is responsible to the Manager, NVOO, for the establishment and implementation of safety criteria within the assigned area. He will be responsible for submitting a plan for all operation to the Manager, NVOO for review and concurrence. Upon termination of need for the Test Group Director to retain control of the test complex, the Test Group Director will be relieved of safety responsibility.

SLA Environmental Health Department

During the time that the Test Group Director has operational safety responsibility, the Environmental Health Department will provide consultants who will advise the Test Group Director on tunnel reentry procedures (for Sandia and Defense Nuclear Agency sponsored events). These consultants will be familiar with the configuration of the test bed, and with possible postshot tunnel conditions and hazards. They will specify the necessary instrumentation to monitor the postshot conditions of the tunnel and will document any radioactive material to the environment. During postshot reentry and recovery operations, they will provide technical direction of radiation and safety and industrial hygiene personnel provided by the NTS Support Contractor.

NTS Support Contractor

Reynolds Electrical & Engineering Company (REECO) is responsible for construction and mine safety for all personnel working underground. REECO will provide the personnel necessary for the support of the tunnel reentry and experiment recoveries. This includes mine-rescue-trained mining personnel, radiation safety monitors, and industrial hygiene and industrial safety personnel.

Preshot Preparations for Reentry

Containment

The stemming should contain the fireball and should thus minimize radioactivity and explosive and toxic gases in the experimental area. If the stemming fails, the overburden plug provides a secondary containment barrier. If the gases penetrate the overburden plug, the gas seal plug and/or the gas seal door should contain the gases within the tunnel complex.

Ventilation System

The tunnel ventilation system is set up so that all areas of the tunnel complex can be swept with fresh air from the portal. Valves which can be remotely operated from a manned location are installed in the ventilation and makeup lines in the gas seal door and/or gas seal plug and the overburden plug. The ventilation system utilizes a positive displacement Sutorbilt blower which is installed so that the air from the tunnel complex passes through a filter system before it is released to the atmosphere. Radiation detectors are placed on the ventilation lines to monitor the radioactive effluent released, and continuous samples are taken from the isotope identification.

Environmental Instrumentation

Radiation detectors are installed in the tunnel complex to supply tunnel reentry personnel with information about radiation levels in the tunnel. Other types of instrumentation which are used to remotely monitor conditions in the tunnel include geophones and pressure and temperature gauges.

Gas Sampling System

Sampling lines for remotely taking gas samples from various points in the tunnel are installed during preparation of the facility for the test. Samples taken from these lines after test execution help to determine the concentration of explosive and toxic gases in the tunnel prior to reentry. Samples can usually be taken from inside the gas seal door and/or the gas seal plug, from both sides of the overburden plug, from the experiment drift near the stemming, and from the horizontal-line-of-side (HLOS) pipe itself.

Reentry Communications System

The reentry communications system provides a communications link between the reentry control group in the trailer at the portal and the reentry party in the tunnel. This system consists of (1) a portable reel of WD-7 field wire and (2) a shielded cable, which is permanently installed in the tunnel. Access to this permanent cable is provided at designated locations along the reentry route. Preshot preparations for an event include installation and checkout of the shielded cable used for reentry communications.

Possible Hazards to Reentry Personnel

Radiation

Reentry teams may encounter radioactivity in the tunnel that results from any one or more of the following:

1. Gross failure of the stemming, in which case large quantities of fission products are deposited throughout the tunnel complex. When this condition exists, the team must be concerned with external radiation hazards and with control of contamination.
2. Seepage of radioactive gases or materials through fissures or fractures from ground zero. In this case, external radiation fields are not usually a significant hazard, but contamination control is of primary concern.
3. Activation of experiment samples and components of the HLOS pipe. If sample integrity is maintained after the event, contamination is only a minor problem and external radiation is the major consideration. If the sample contaminant is ruptured and the sample is dispersed throughout the test chamber, contamination control is of primary concern.

Explosive and Toxic Gases

Explosive and toxic gases may be produced as directed or secondary products of the detonation of the device. They may also be produced by the detonation of explosives used in some experimental samples or in HLOS pipe closure systems. These gases may be present in concentrations that are hazardous to personnel.

Tunnel Damage

The ground motion associated with the detonation of the device may cause structural damage to the tunnel. All reentry team members must be alert for unstable overhead conditions, such as hanging slabs and broken timber. They should also watch for broken ventilation lines and utility lines (water, compressed air, electrical cables). Physical damage to the tunnel may be at times be such that rehabilitation of the drift must be accomplished before experiment recoveries can be initiated.

Explosives

Explosives are associated with pipe closure and sample protection systems, and may also be present as part of some of the experiments. These explosives, which may still be unexpended after the test, may have been sensitized by the exposure to the device radiation. If the unexpended explosives are contained in experiments in which the sample integrity has been maintained, they do not pose a significant hazard for initial reentry teams. However, team members should be aware of the possibility of unexpended high explosives lying on the bottom of the HLOS pipe.

Toxic Materials

Experiments to be exposed to radiations from the device may contain materials which have some degree of chemical toxicity. In particular, many experiments contain beryllium or have beryllium filters, a portion of which will be present in the postshot environment as finely divided dust. These materials are of concern primarily during postshot recovery of experiments when it is extremely probable that a portion of the dust will become airborne.

High-Pressure Gas Cylinders

Some experiments typically have pressurized gas as an integral part of the experimental system. The gas is usually supplied from high-pressure (2200 psi) gas cylinders which may have been damaged as a result of ground motion or high temperature. Reentry personnel must exercise caution around pressurized systems and will check them to see that the pressure has been bled off.

Reentry Party Composition and Equipment

A team for reentry into a tunnel following a nuclear test shall consist of a minimum of five personnel, one of whom shall be designated as a team chief. He will be responsible for the team during all work underground. All personnel participating as members of initial reentry parties must be certified in the use of USBM* -approved self-contained breathing apparatus. Composition of the reentry parties and their equipment is summarized in Table 1.

*U.S. Bureau of Mines

TABLE I

Summary of Reentry Parties and Equipment

Party Name	Equipment
<u>Initial Reentry Parties</u>	
1. Team Chief	Full Radex Clothing USBM-approved, 2-hour self-contained breathing apparatus
2. Radiation Safety Monitor	Radiation detectors
3. Industrial Hygiene Monitor	Explosimeter
4. Two or More Miners	Toxic gas indicators Oxygen detector Hard-wire communications
<u>Work Party</u>	
1. Team Chief	Full Radex clothing Respiratory protection (as required)
2. Radiation Safety Monitor	Radiation detectors
3. Industrial Hygiene Monitor	Explosimeter
4. Miners and Support Personnel	Toxic gas indicators Oxygen detector
<u>Rescue Team</u>	
1. Team Chief	Full Radex clothing USBM-approved, 2 hour self-contained breathing apparatus
2. Radiation Safety Monitor	Radiation detectors
3. Industrial Hygiene Monitor	Explosimeter
4. Two or More Mine-Rescue Trained Personnel	Toxic gas indicators Oxygen detector Wire litters
<u>Scientific Assessment Team</u>	
1. Team Chief	Full Radex clothing Respiratory protection (as required)
2. Radiation Safety Monitor	Radiation detectors
3. Industrial Hygiene Monitor	Explosimeter
4. Scientific Advisors	Toxic gas indicators
5. Mine Support Personnel	Oxygen detector

Guidelines for Initial Reentry Parties

Authorization

Initial reentry and each subsequent phase will be initiated upon authorization of the Test Group Director (TGD) with the concurrence of the Test Controller. Operational control will be retained by the TGD until all recovery and reentry mining operations are completed and tunnel access is returned to AEC control.

Activating and Monitoring Tunnel Ventilation System

Tunnel reentry will not start until after the tunnel ventilation system has been activated and samples of tunnel air have been taken and monitored at the portal. Evaluation of these samples must indicate that reentry can be made within the limitations of this procedure.

Reentry Control Group

The reentry control group will normally be composed of an SLA ENvironmental Health consultant, the TGD or his designated alternate, the tunnel construction engineer or some other person who has an intiamte knowledge of tunnel construction details, a REECo Rad-Safe Superintendent, and a senior industrial hygienist. All activities of the reentry party in the tunnel are performed at the direction of this group, and any deviations from the guidelines presented in this procedure are by a consensus of its members. Communications between the reentry control group and the reentry party in the tunnel will be maintained whenever reentry teams are underground. All observations by team members during reentry will be communicated through the team chief to the reentry control group and will be recorded for future reference. Only one team will be in the tunnel at any one time unless otherwise directed by the reentry control group.

Team Limitations

Personnel radiation exposure limits for a reentry operation are 3 rem per calendar quarter (NTSO SOP Chapter 0524). If it is assumed that a person's exposure history would allow an accumulation of 3 rem during the operation, his exposure will be terminated when his pocket dosimeter indicates an accumulated exposure of 2 rem.

Except under extenuating circumstances and by mutual decision of the reentry control group and the team chief, reentry teams will not enter radiation fields greater than 10 R/h, nor will they enter ares in which the concentration of carbon monoxide is greater than 1000 ppm or the concentration of explosive gases is greater than 30 percent of the lower explosive limit (LEL).

Self-Contained Breathing Apparatus

Prior to entry into any potentially hazardous atmosphere, the self-contained breathing apparatus of each team member will be personally checked by the team chief and/or another certified person for proper fit and operation. Malfunctions of the breathing apparatus of any team member shall cause the reentry mission to be aborted.

Emergency Return to Portal

A reentry party will return to the portal as a result of any of the following conditions:

1. On decision of the team chief.
2. When any member of the reentry team has a McCaa oxygen supply less than 30 atmospheres or a Draeger pressure less than 450 psi.
3. On loss of communications with the reentry control group at the portal.

Rescue Team

A rescue team will be stationed near the portal or at the fresh air station underground at all times that reentry teams are in the tunnel. If located at the portal, the rescue team will have a train available for immediate departure. The rescue team will be dispatched only at the direction of the reentry control group and only after it has been determined that the rescue team can conduct its mission safely.

Medical Support

A medical technician with an ambulance and the necessary medical equipment will be available at the portal during initial reentry operations. This medical support will be released only at the direction of the reentry control group.

Summary of Initial Tunnel Reentries

This plan is written as though one team can complete the entire reentry operation. In actual practice, several teams will probably be necessary. AS many teams as are needed will be used to complete the tunnel exploration.

Preparation of Tunnel for Reentry

As soon as possible after the event, and with the concurrence of the Test Controller, the tunnel ventilation system will be activated. The tunnel complex will be further prepared for reentry by securing all unnecessary power going into the tunnel. All downhole cables from the mesa trailer park will be disconnected in the cable splice shack and each cable termination will be taped. CABLES WILL NOT BE CUT WITHOUT SPECIAL AUTHORIZATION FROM THE TEST GROUP DIRECTOR. All electrical power to the mesa trailer park will be turned off. All instrumentation and utility power cables and telephone lines going into the tunnel from the portal will be disconnected or confirmed to be off. Cables for the tunnel ventilation system, the temperature and pressure monitors, the geophones, and the remote radiation monitoring system will be left connected.

Evaluation of Tunnel Environment

The reentry control group will review the data from the radiation system, the temperature and pressure monitors, the geophones, and the gas samples taken from the tunnel complex to assure that the reentry can be made within the limitations of this procedure. With this assurance, and when cleared by the TGD and the Test Controller, the reentry operation may begin. No changes will be made in the tunnel ventilation system or in any electrical system while reentry teams are underground.

Exploration of Tunnel

The reentry team will enter the tunnel by using a diesel locomotive for transportation and will proceed to the gas seal door. The team will monitor continuously for radioactivity and for toxic and explosive gases. These readings, as well as the progress of the team and the physical condition of the tunnel, will be reported to the reentry control group. Pressure gauges at the gas seal door will be checked, and a gas sample will be taken through the door to determine the environment on the working point side of the door. If conditions are satisfactory, the team will open the gas seal door and proceed to the gas seal plug.

The pressure gauges at the gas seal plug will be checked, and a gas sample will be taken from the working point side of the plug to determine the environment. If ventilation has not been reestablished remotely through this plug, the team will take the necessary steps to establish ventilation through the plug. If conditions permit, the team will then proceed to the overburden plug, where the same procedure will be followed.

After ventilation to the working point side of the overburden plug has been established and it has been determined that explosive and toxic gases are below the reentry guideline concentrations, the team will proceed through the overburden plug and check out the experiment drift complex. Team members will walk to the portal face of the stemming, if possible, monitoring continuously for radioactivity and for toxic and explosive gases. They will also observe the ventilation lines to assure themselves that the lines are intact, and will report this information, along with the general condition of the tunnel and the HLOS pipe, to the reentry control group. After the condition of the tunnel has been determined, the team will establish ventilation to the HLOS pipe. The doors to the test chambers will be opened and swipes will be taken from the floor of the test chambers. These swipes will be analyzed for beryllium and will also be used to identify the radionuclides present inside the HLOS pipe.

As soon as the reentry team has verified that the tunnel complex is within acceptable levels for radiation and for toxic and explosive gases and has determined the physical condition of the tunnel and HLOS pipe, the initial reentry operation is complete.

Scientific Assessment of the Experiments

Scientific Assessment Team

As soon as the initial reentry teams have verified that the tunnel and HLOS pipe are clear of hazardous amounts of radiation and of toxic and explosive gases and as soon as the physical hazards have been identified and repaired, as necessary, the scientific assessment team will enter the HLOS pipe and observe the condition of the experiments.

Photographic Documentation -- Photographic documentation of the condition of each experimental station may take place concurrently with or immediately after preliminary assessment of the experiments.

Removal of Unexpended Explosives -- Unexpended explosives which are found to be uncontained will be removed from the HLOS pipe before experiment recoveries are begun.

Recovery of Experiments From the Test Chambers

Before scientific recoveries may be begun, repair of the tunnel to the test chambers must be complete. This activity may include repairing broken lagging and removing hazardous conditions, as well as repairing railroad track and ventilation lines. Tunnel utility power will be restored before experiment recoveries (except for recovery of film) are begun.

After tunnel repairs have been completed, experiment agencies will be permitted to begin recovery of samples from the test chambers in order of priority. A radiation safety monitor will be present at the test chambers at all times to assist the experimenters and to help control contamination.

APPENDIX D

U. S. ATOMIC ENERGY COMMISSION STANDARD OPERATING PROCEDURE NEVADA TEST SITE ORGANIZATION

NTSO-05240-01

Chapter 0524

RADIOLOGICAL SAFETY

0524-01 Radiological Safety

011 Purpose

The purpose of this Standard Operating Procedure is to define responsibility and to establish criteria and general procedures for radiological safety associated with NTS programs. Additional operational instructions relating to radiological safety for particular activities may be published as a part of the Test Manager's Operational Plan.

012 Responsibilities

- a. Manager, NVOO. The Manager, NVOO, is the AEC official to whom the NTSO reports. The Manager, NVOO, as a Test Manager, is responsible for administering, preparing, and executing all programs and projects. The Test Manager may delegate operational control of the NTSO to specifically-identified Deputy Test Managers for the execution of approved programs, projects, and experiments. Only the Test Manager or the Deputy Test Manager is authorized to approve or disapprove the field execution of approved programs, projects or experiments.
- b. Test Manager. The Test Manager is responsible for the protection of participating personnel and off-site population from radiation hazards associated with activities conducted at the NTS. By mutual agreement between the Test Manager and a scientific user, control of radiological safety within the area assigned for a particular activity may be delegated to the user's Test Group Director during the period of time when such control could have a direct bearing on the success or failure of the scientific program. The provisions of AEC Manual Chapter 8401 shall apply to reactor tests or sustained reactor operations.
- c. Test Group Director. Whenever operational radiological safety control is delegated to a Test Group Director under provisions of 012a above, he is responsible to the Test Manager for establishment and implementation of radiological safety criteria within the assigned area. He will be responsible for submitting a detailed radiological safety operational plan to the

Test Manager for review and concurrence. This plan shall be submitted as Standard Operating Procedures (SOP) to cover all routine operations. Variances from the SOP for non-routine operations shall be presented to the Test Manager for review and concurrence. Upon termination of need for the Test Group Director to retain radiological safety control within an assigned area, the Test Group Director will be relieved of radiological safety responsibility.

- d. Director, Nevada Test Site Support Office (NTSSO). Supervises the approved NTS on-site radiological safety programs, except for those periods in which operational control of specified areas may be delegated to others (i.e., Test Manager, Test Group Directors, etc.).
- e. Radiological Safety Advisor. The NTSO Radiological Safety Advisor is responsible to the Test Manager for staff supervision of radiological safety policies and procedures at the NTS. Monitoring of the radiological safety policies and direction of procedures at NTS, during non-operational periods, rests with the Director, NTSSO.
- f. Chief, Safety Branch (SB), NTSSO. The Chief, Safety Branch, NTSSO, will be responsible to the Director, NTSSO, for conducting field inspections at the NTS to assure that NTS contractors execute safety programs in accordance with approved safety procedures and plans as well as with AEC and NVOO directives. Recommends corrective actions where necessary. Assures that radioactive waste management and disposal are accomplished in accordance with approved procedures. Coordinates and administers NTS activities relative to the Radiological Assistance Program. Provides day-by-day coordination and monitoring of NTS radiological safety activities, except for those periods during which operational control of specified areas may be delegated to others.
- g. Director, Safety Evaluation Division (SED), NVOO. Provides for staff development of safety programs of NVOO for use at NTS. Develops safety programs which are coordinated with NTSSO and site user agencies and organizations to meet public and operational safety requirements for the conduct of nuclear detonations, reactor test programs, chemical explosives tests, or other NVOO activities. Arranges for radiological studies as may be appropriate.

- h. Chief, Radiological Safety Branch (RSB), NVOO. Provides staff assistance in all matters relating to radiological safety. Reviews and evaluates for technical adequacy radiological safety procedures and operational plans submitted by user organizations. Acts as Radiological Safety Advisor (or provides a representative) to the Test Manager during all NVOO activities requiring such coverage.
- i. Off-Site Radiological Safety Officer. The Director, Southwestern Radiological Health Laboratory, U. S. Public Health Service, or his representative, will be designated as the Off-Site Radiological Safety Officer and is responsible to the Test Manager for the operation of the off-site radiological safety program.
- j. User Organizations. The official in charge of each agency or organizational group participating in NTS field activities or using NTS facilities is responsible for compliance by his personnel with established radiological safety policies, procedures, and controls. Each official in charge of a participating group is also responsible at all times to his parent organization for the radiological safety of personnel under his supervision. Operational safety plans will be submitted by the user organization to the Test Manager for review and approval, with a copy to the Director, NTSSO.
- k. Operations Coordination Center (OCC). Shipment of radioactive materials, radioactive waste disposal, and access to areas contaminated with radioactive debris require prior coordination through the Operations Coordination Center, CP-1, telephone Mercury 986-2781.
- l. On-Site Radiological Organization. On-site radiological safety support services for user organizations and the routine operation of NTS will be provided by the on-site radiological safety support contractor as directed by the NTSSO. Routing radiological safety support services at NTS will be requested in writing by the user organization through the Director, NTSSO. The on-site radiological safety support contractor is responsible to the Test Manager, through the Director, NTSSO, for the following routine on-NTS radiological safety support.
 - 1. Providing radiological safety support, including certified monitors to user organizations.
 - 2. Making radiological surveys, documenting radiation levels from events on the NTS, mapping and properly marking all contaminated areas, and furnishing this survey information for distribution by the Chief, Safety Branch, NTSSO.

3. Conducting a personnel radiation dosimetry program and disseminating the results of the program to respective organizations covered under this program, and as appropriate under AEC Manual Chapter 0525 and Appendix. This program to include providing and maintaining a repository for records and source documents pertaining to personnel dosimetry for all NVOO activities requiring such dosimetry.
4. Maintaining and calibrating radiation detection equipment.
5. Procuring, issuing, and decontaminating protective clothing, supplies, and equipment.
6. Providing radioactive materials and waste disposal control (including receiving, storage, on-site movement and shipping).
7. Maintaining and operating personnel and equipment decontamination facilities.
8. Providing advice and assistance in matters pertaining to radiological safety.
9. Conducting an on-site environmental surveillance program.
10. Providing necessary support services for the off-site radiological safety program.
11. Conducting radiological safety training courses.
12. Preparing final on-site reports following each test operational period, interim reports for each event, special reports and detailed operational plans for each future program.
13. Providing Radiological Assistance Teams to respond to radiation incidents.
14. Conducting analysis of samples for radioactivity and for certain toxic materials.
15. Providing and maintaining a current manual containing the Standard Operating Procedures (SOP) for providing radiological safety support, as outlined above, to users and contractors at the NTS.

- m. Other. Other responsibilities as well as more detailed versions of the above, are spelled out in NTSO-0103.

0524-02 Organization

The chart showing the organizational relationship of the NTS radiological safety activities is shown in Figure 1 on the following page.

0524-03 Definitions

- a. Radiological Safety. The protection of personnel, population groups, and the environment from the effects of ionizing radiation.
- b. Ionizing Radiation. Electromagnetic radiation (consisting of photons) or particulate radiation (consisting of electrons, neutrons, protons, etc.) usually of high energy, but in any case capable of ionizing air, directly or indirectly.
- c. NTS. The Nevada Test Site.
- d. On-Site. Areas within the NTS boundaries, including Mercury.
- e. Certified Monitor. Any person certified to the Test Manager or his designated representative as a qualified monitor by a Test Group Director or the Radiological Safety Representative of the radiological safety services.
- f. Radiation Exclusion Area (Radex). A limited access area designated and posted for radiological safety purposes.
- g. Controlled Area. Any area to which access is controlled by the AEC or AEC contractors.
- h. User. Any organization or test participant having a NVOO-approved technical program for conduct at the NTS.
- i. Radiation Incident. Any alleged radiation accident, which if true, could result in property damage or loss, injury, over exposure, or excessive release of radioactive materials.
- j. Roentgen. A unit of exposure to X or gamma radiation. 1 mR (one milliRoentgen) is one-one thousandth of one Roentgen.
- k. Rad. A unit of absorbed dose equivalent to 100 ergs/gram.

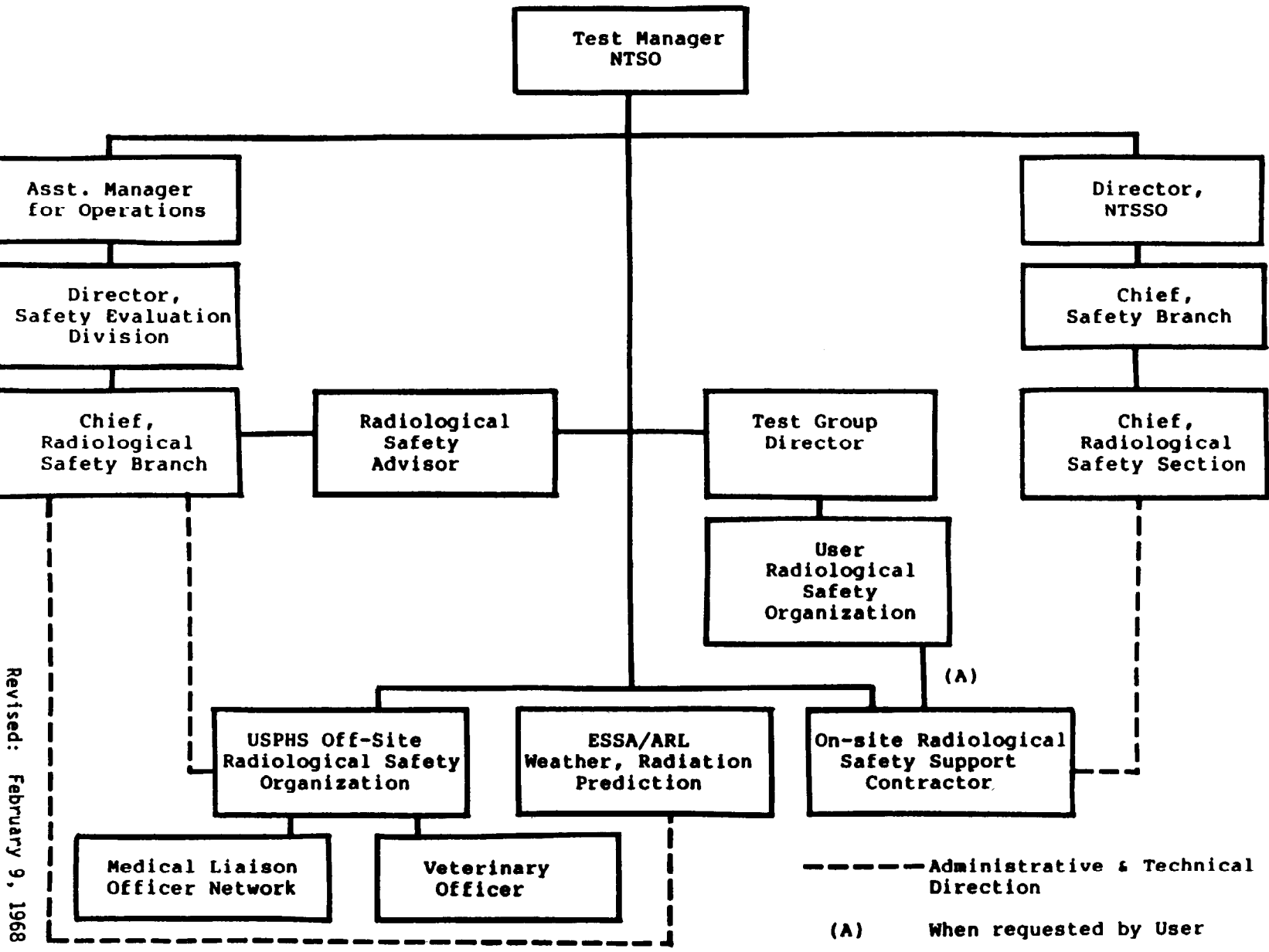

Revised: February 9, 1968

Figure I. Organization Chart Radiological Safety Activities

- i. Rem. A unit of dose equivalent. It is a unit found convenient in practice to express exposures to different types of ionizing radiation in terms that combine both the magnitude of the absorbed dose and its biological effectiveness. The dose equivalent is numerically equal to the dose in rads multiplied by the appropriate modifying factors.
- m. Exposure Rate or Dose Rate. The time rate at which exposure or dose is measured or administered, i.e., dose or exposure per unit time, such as R/hr, rem/min, rad/hr, R/sec, etc.

0524-04 Radiation Protection Standards

- 041 Coverage. These standards shall govern ionizing radiation exposure to AEC and AEC contractor personnel and to other individuals who may be exposed to ionizing radiation from operations of the AEC and AEC contractors. These standards do not apply to radiation exposures resulting from natural radiation, medical and dental procedures, nor do they apply to the general population when the activities involved are essential to national security, such as nuclear weapons testing. The latter types of activities are covered by separate criteria. Safety criteria for each Plowshare event will be considered separately until such time as over-all policy for the Plowshare program is established. No operation shall be conducted until the radiological hazard has been evaluated and it has been determined to the satisfaction of the Test Manager, or the Test Group Director (when he has been delegated the radiological safety responsibility for the operation) that radiation exposures should not exceed the radiation protection standards established in AEC Manual Chapter 0524 (repeated below). Except for emergencies, written requests to expose personnel in excess of these limits should be directed to the Test Manager.

1. RADIATION PROTECTION STANDARDS FOR INDIVIDUALS IN CONTROLLED AREAS¹A. Radiation from sources external to the body

<u>Type of Exposure</u>	<u>Period of Time</u>	<u>Dose (rem)</u>
Whole body, head and trunk, active blood-forming organs gonads, or lens of eye.	Accumulated dose	5 (N-18) ²
	Calendar quarter ³	3 ⁴
Skin of whole body and thyroid	Year	30 ⁴
	Calendar quarter ³	10 ⁴
Hands, and forearms, feet and ankles	Year	75 ⁴
	Calendar quarter ³	25 ⁴

B. Radiation from emitters internal to the body

1. Except as provided in 2, below, the radiation protection standards for airborne radioactivity specified in annex I, table I, shall be followed. The concentration standards are based upon continuous exposure to the concentrations specified for forty hours per week (a "week" being seven consecutive days). For the purpose of applying these standards, radioactivity concentrations may be

averaged over periods up to 13 consecutive weeks provided work areas are appropriately monitored and exposure histories are maintained for each individual working in such areas.

2. If it is not feasible to govern exposures to internal emitters by applying airborne radioactivity concentration standards, the following radiation protection standards shall apply:

<u>Type of Exposure</u>	<u>rem/year</u>	<u>Dose</u>	
		<u>rem/quarter</u>	
Whole body, active blood-forming organs, gonads.	5	3	
Thyroid	30	10	
Bone	Body burden of 0.1 microgram of radium-226 or its biological equivalent ⁵	--	
Other organs	15	5	

The calculation of organ dose shall be based on methods recommended by the Federal Radiation Council and the In-

ternational Commission on Radiological Protection.

¹An individual under age 18 shall not be employed in or allowed to enter controlled areas in such manner that he will receive doses of radiation in amounts exceeding the standards applicable to individuals in uncontrolled areas. Exposures to individuals under age 18 may be averaged over periods not to exceed one calendar quarter.

²N equals the age in years at last birthday. An individual employed at age 18 or an individual beyond age 18 who had no accrued unused exposure shall not be exposed during the ensuing year to doses exceeding (a) 1.25 rem for the first calendar quarter, (b) 2.5 rem total for the first two calendar quarters, (c) 3.75 rem total for the first

three calendar quarters and (d) 5 rem for the year, but in no case will exposure be more than 3 rem per quarter.

³A calendar quarter may be taken as a predetermined period of 13 consecutive weeks or any predetermined quarter year based on the calendar.

⁴Personnel monitoring equipment shall be provided each individual who receives or is likely to receive a dose in any calendar quarter in excess of 10% of these values.

⁵Exposure must be governed such that the individual's body burden does not exceed this value (a) when averaged over any period of 12 consecutive months and (b) after 50 years of occupational exposure.

II. RADIATION PROTECTION STANDARDS FOR INDIVIDUALS AND POPULATION GROUPS IN UNCONTROLLED AREAS

A. Radiation dose standards for external and internal exposure

<u>Type of Exposure</u>	<u>Dose (rem/year)</u>	
	<u>Based on exposure to individuals</u>	<u>Based on an average exposure to a suitable population sample</u>
Whole body, gonads or bone marrow	0.5	0.17
Thyroid or bone	1.5	0.5
Bone (alternate standard)	Body burden of 0.003 μ g of radium 226 or its biological equivalent.	Body burden of 0.001 μ g of radium 226 or its biological equivalent.

B. Radioactivity in effluents released to uncontrolled areas

1. Except as provided in 2. below, radioactivity in effluents released to uncontrolled areas shall not exceed the radiation protection standards specified in annex I, table II. The point of release of such effluents shall be considered to be the point at which the effluents pass beyond the site boundary. Where such effluents are discharged through a conduit such as a stack or pipe, the point of release may be considered to be the conduit discharge. For the purpose of applying these standards, radioactivity concentrations in effluents may be averaged over periods up to one year.

2. Radioactivity in effluents may be released to uncontrolled areas in excess of the radiation protection standards specified in annex I, table II, provided it is reasonably demonstrated that in uncontrolled areas:

(a) individuals are not exposed in excess of the standards specified in A. above.

(b) individuals are not exposed in excess of annex I, table II standards, or

(c) the average exposure of a suitable sample of an exposed population group is not in excess of one-third of annex I, table II standards. Radioactivity concentrations in the environment may be averaged over periods up to one year.

3. In any situation in which the contribution to radioactivity in the environment from effluents discharged by one or more activities of the AEC or AEC contractors is likely to result in exposures in excess of the standards specified in II.A. and B. above, lower effluent concentration limits may be set for these Operations. In such cases, the manager of the field office may take the necessary corrective action if all activities concerned are within his area of responsibility. Otherwise, each case will be referred to the Director, Division of Operational Safety, for appropriate action.

ANNEX I

CONCENTRATIONS IN AIR AND WATER ABOVE NATURAL BACKGROUND

(See notes at end of annex)

Element (atomic number)	Isotope ¹		Table I		Table II	
			Column 1	Column 2	Column 1	Column 2
			Air ($\mu\text{c}/\text{ml}$)	Water ($\mu\text{c}/\text{ml}$)	Air ($\mu\text{c}/\text{ml}$)	Water ($\mu\text{c}/\text{ml}$)
Actinium (89).....	Ac 227	S	2×10^{-12}	6×10^{-5}	8×10^{-14}	2×10^{-6}
		I	3×10^{-11}	9×10^{-3}	9×10^{-13}	3×10^{-4}
	Ac 228	S	8×10^{-8}	3×10^{-3}	3×10^{-9}	9×10^{-5}
		I	2×10^{-8}	3×10^{-3}	6×10^{-10}	9×10^{-5}
Americium (95).....	Am 241	S	6×10^{-12}	1×10^{-4}	2×10^{-13}	4×10^{-6}
		I	1×10^{-10}	8×10^{-4}	4×10^{-12}	2×10^{-5}
	Am 243	S	6×10^{-12}	1×10^{-4}	2×10^{-13}	4×10^{-6}
		I	1×10^{-10}	8×10^{-4}	4×10^{-12}	3×10^{-5}
Antimony	Sb 122	S	2×10^{-7}	8×10^{-4}	6×10^{-9}	3×10^{-5}
		I	1×10^{-7}	8×10^{-4}	5×10^{-9}	3×10^{-5}
	Sb 124	S	2×10^{-7}	7×10^{-4}	5×10^{-9}	2×10^{-5}
		I	2×10^{-8}	7×10^{-4}	7×10^{-10}	2×10^{-5}
	Sb 125	S	5×10^{-7}	3×10^{-3}	2×10^{-8}	1×10^{-4}
		I	3×10^{-8}	3×10^{-3}	9×10^{-10}	1×10^{-4}
Argon (18)	A 37	Sub ²	6×10^{-3}	1×10^{-4}
		Sub	2×10^{-6}	4×10^{-8}
Arsenic (33)	As 73	S	2×10^{-6}	1×10^{-2}	7×10^{-8}	5×10^{-4}
		I	4×10^{-7}	1×10^{-2}	1×10^{-8}	5×10^{-4}
	As 74	S	3×10^{-7}	2×10^{-3}	1×10^{-8}	5×10^{-5}
		I	1×10^{-7}	2×10^{-3}	4×10^{-9}	5×10^{-5}
	As 76	S	1×10^{-7}	6×10^{-4}	4×10^{-9}	2×10^{-5}
		I	1×10^{-7}	6×10^{-4}	3×10^{-9}	2×10^{-5}
	As 77	S	5×10^{-7}	2×10^{-3}	2×10^{-8}	8×10^{-5}
		I	4×10^{-7}	2×10^{-3}	1×10^{-8}	8×10^{-5}
Astatine (85)	At 211	S	7×10^{-9}	5×10^{-5}	2×10^{-10}	2×10^{-6}
		I	3×10^{-8}	2×10^{-3}	1×10^{-9}	7×10^{-5}
Barium (56)	Ba 131	S	1×10^{-6}	5×10^{-3}	4×10^{-8}	2×10^{-4}
		I	4×10^{-7}	5×10^{-3}	1×10^{-8}	2×10^{-4}
	Ba 140	S	1×10^{-7}	8×10^{-4}	4×10^{-9}	3×10^{-5}
		I	4×10^{-8}	7×10^{-4}	1×10^{-9}	2×10^{-5}
Berkelium (97)	Bk 249	S	9×10^{-10}	2×10^{-2}	3×10^{-11}	6×10^{-4}
		I	1×10^{-7}	2×10^{-2}	4×10^{-9}	6×10^{-4}
Beryllium (4)	Be 7	S	6×10^{-6}	5×10^{-2}	2×10^{-7}	2×10^{-3}
		I	1×10^{-6}	5×10^{-2}	4×10^{-8}	2×10^{-3}
Bismuth (83)	Bi 206	S	2×10^{-7}	1×10^{-3}	6×10^{-9}	4×10^{-5}
		I	1×10^{-7}	1×10^{-3}	5×10^{-9}	4×10^{-5}

CONCENTRATIONS IN AIR AND WATER ABOVE NATURAL BACKGROUND-continued

(See notes at end of annex)

Element (atomic number)	Isotope ¹		Table I		Table II		
			Column 1 Air ($\mu\text{c}/\text{ml}$)	Column 2 Water ($\mu\text{c}/\text{ml}$)	Column 1 Air ($\mu\text{c}/\text{ml}$)	Column 2 Water ($\mu\text{c}/\text{ml}$)	
	Bi 207	S	2×10^{-7}	2×10^{-3}	6×10^{-9}	6×10^{-5}	
		I	1×10^{-8}	2×10^{-3}	5×10^{-10}	6×10^{-5}	
	Bi 210	S	6×10^{-9}	1×10^{-3}	2×10^{-10}	4×10^{-5}	
		I	6×10^{-9}	1×10^{-3}	2×10^{-10}	4×10^{-5}	
	Bi 212	S	1×10^{-7}	1×10^{-2}	3×10^{-9}	4×10^{-4}	
		I	2×10^{-7}	1×10^{-2}	7×10^{-9}	4×10^{-4}	
	Bromine (35)	Br 82	S	1×10^{-6}	8×10^{-3}	4×10^{-8}	3×10^{-4}
			I	2×10^{-7}	1×10^{-3}	6×10^{-9}	4×10^{-5}
	Cadmium (48)	Cd 109	S	5×10^{-8}	5×10^{-3}	2×10^{-9}	2×10^{-4}
			I	7×10^{-8}	5×10^{-3}	3×10^{-9}	2×10^{-4}
	Cd 115m	S	4×10^{-8}	7×10^{-4}	1×10^{-9}	3×10^{-5}	
		I	4×10^{-8}	7×10^{-4}	1×10^{-9}	3×10^{-5}	
	Cd 115	S	2×10^{-7}	1×10^{-3}	8×10^{-9}	3×10^{-5}	
		I	2×10^{-7}	1×10^{-3}	6×10^{-9}	4×10^{-5}	
	Calcium (20)	Ca 45	S	3×10^{-8}	3×10^{-4}	1×10^{-9}	9×10^{-6}
			I	1×10^{-7}	5×10^{-3}	4×10^{-9}	2×10^{-4}
	Ca 47	S	2×10^{-7}	1×10^{-3}	6×10^{-9}	5×10^{-5}	
		I	2×10^{-7}	1×10^{-3}	6×10^{-9}	3×10^{-5}	
	Californium (98)	Cf 249	S	2×10^{-12}	1×10^{-4}	5×10^{-14}	4×10^{-6}
			I	1×10^{-10}	7×10^{-4}	3×10^{-12}	2×10^{-5}
Cf 250		S	5×10^{-12}	4×10^{-4}	2×10^{-13}	1×10^{-5}	
		I	1×10^{-10}	7×10^{-4}	3×10^{-12}	3×10^{-5}	
	Cf 252	S	2×10^{-11}	7×10^{-4}	7×10^{-13}	2×10^{-5}	
		I	1×10^{-10}	7×10^{-4}	4×10^{-12}	2×10^{-5}	
	Carbon (6)	C 14	S	4×10^{-6}	2×10^{-2}	1×10^{-7}	8×10^{-4}
			(CO ₂) Sub	5×10^{-5}	1×10^{-6}
	Cerium (58)	Ce 141	S	4×10^{-7}	3×10^{-3}	2×10^{-8}	9×10^{-5}
			I	2×10^{-7}	3×10^{-3}	5×10^{-9}	9×10^{-5}
	Ce 143	S	3×10^{-7}	1×10^{-3}	9×10^{-9}	4×10^{-5}	
		I	2×10^{-7}	1×10^{-3}	7×10^{-9}	4×10^{-5}	
	Ce 144	S	1×10^{-8}	3×10^{-4}	3×10^{-10}	1×10^{-5}	
		I	6×10^{-9}	3×10^{-4}	2×10^{-10}	1×10^{-5}	
Cesium (55)	Cs 131	S	1×10^{-5}	7×10^{-2}	4×10^{-7}	2×10^{-3}	
		I	3×10^{-6}	3×10^{-2}	1×10^{-7}	9×10^{-4}	
	Cs 134m	S	4×10^{-5}	2×10^{-1}	1×10^{-6}	6×10^{-3}	
		I	6×10^{-6}	3×10^{-2}	2×10^{-7}	1×10^{-3}	
	Cs 134	S	4×10^{-8}	3×10^{-4}	1×10^{-9}	9×10^{-6}	
I	1×10^{-8}	1×10^{-3}	4×10^{-10}	4×10^{-5}			

CONCENTRATIONS IN AIR AND WATER ABOVE NATURAL BACKGROUND-continued

(See notes at end of annex)

Element (atomic number)	Isotope ¹	Table I		Table II			
		Column 1 Air ($\mu\text{c/ml}$)	Column 2 Water ($\mu\text{c/ml}$)	Column 1 Air ($\mu\text{c/ml}$)	Column 2 Water ($\mu\text{c/ml}$)		
Cesium (55)	Cs 135	S	5×10^{-7}	3×10^{-3}	2×10^{-8}	1×10^{-4}	
		I	9×10^{-8}	7×10^{-3}	3×10^{-9}	2×10^{-4}	
	Cs 136	S	4×10^{-7}	2×10^{-3}	1×10^{-8}	9×10^{-5}	
		I	2×10^{-7}	2×10^{-3}	6×10^{-9}	6×10^{-5}	
Cesium (55)	Cs 137	S	6×10^{-8}	4×10^{-4}	2×10^{-9}	2×10^{-5}	
		I	1×10^{-8}	1×10^{-3}	5×10^{-10}	4×10^{-5}	
	Chlorine (17)	Cl 36	S	4×10^{-7}	2×10^{-3}	1×10^{-8}	8×10^{-5}
Chlorine (17)		I	2×10^{-8}	2×10^{-3}	8×10^{-10}	6×10^{-5}	
	Cl 38	S	3×10^{-6}	1×10^{-2}	9×10^{-8}	4×10^{-4}	
		I	2×10^{-6}	1×10^{-2}	7×10^{-8}	4×10^{-4}	
Chromium (24)	Cr 51	S	1×10^{-5}	5×10^{-2}	4×10^{-7}	2×10^{-3}	
		I	2×10^{-6}	5×10^{-2}	8×10^{-8}	2×10^{-3}	
Cobalt (27)	Co 57	S	3×10^{-6}	2×10^{-2}	1×10^{-7}	5×10^{-4}	
		I	2×10^{-7}	1×10^{-2}	6×10^{-9}	4×10^{-4}	
	Co 58m	S	2×10^{-5}	8×10^{-2}	6×10^{-7}	3×10^{-3}	
		I	9×10^{-6}	6×10^{-2}	3×10^{-7}	2×10^{-3}	
	Co 58	S	8×10^{-7}	4×10^{-3}	3×10^{-8}	1×10^{-4}	
		I	5×10^{-8}	3×10^{-3}	2×10^{-9}	9×10^{-5}	
	Co 60	S	3×10^{-7}	1×10^{-3}	1×10^{-8}	5×10^{-5}	
		I	9×10^{-9}	1×10^{-3}	3×10^{-10}	3×10^{-5}	
	Copper (29)	Cu 64	S	2×10^{-6}	1×10^{-2}	7×10^{-8}	3×10^{-4}
		I	1×10^{-6}	6×10^{-3}	4×10^{-8}	2×10^{-4}	
Curium (96)	Cm 242	S	1×10^{-10}	7×10^{-4}	4×10^{-12}	2×10^{-5}	
		I	2×10^{-10}	7×10^{-4}	6×10^{-12}	3×10^{-5}	
	Cm 243	S	6×10^{-12}	1×10^{-4}	2×10^{-13}	5×10^{-6}	
		I	1×10^{-10}	7×10^{-4}	3×10^{-12}	2×10^{-5}	
	Cm 244	S	9×10^{-12}	2×10^{-4}	3×10^{-13}	7×10^{-6}	
		I	1×10^{-10}	8×10^{-4}	3×10^{-12}	3×10^{-5}	
	Cm 245	S	5×10^{-12}	1×10^{-4}	2×10^{-13}	4×10^{-6}	
		I	1×10^{-10}	8×10^{-4}	4×10^{-12}	3×10^{-5}	
	Cm 246	S	5×10^{-12}	1×10^{-4}	2×10^{-13}	4×10^{-6}	
		I	1×10^{-10}	8×10^{-4}	4×10^{-12}	3×10^{-5}	
Dysprosium (66)	Dy 165	S	3×10^{-6}	1×10^{-2}	9×10^{-8}	4×10^{-4}	
		I	2×10^{-6}	1×10^{-2}	7×10^{-8}	4×10^{-4}	
	Dy 166	S	2×10^{-7}	1×10^{-3}	8×10^{-9}	4×10^{-5}	
Erbium (68)		I	2×10^{-7}	1×10^{-3}	7×10^{-9}	4×10^{-5}	
	Er 169	S	6×10^{-7}	3×10^{-3}	2×10^{-8}	9×10^{-5}	
		I	4×10^{-7}	3×10^{-3}	1×10^{-8}	9×10^{-5}	

CONCENTRATIONS IN AIR AND WATER ABOVE NATURAL BACKGROUND-continued

(See notes at end of annex)

Element (atomic number)	Isotope ¹	Table I		Table II		
		Column 1 Air ($\mu\text{c/ml}$)	Column 2 Water ($\mu\text{c/ml}$)	Column 1 Air ($\mu\text{c/ml}$)	Column 2 Water ($\mu\text{c/ml}$)	
Europium (63)	Er 171	S	7×10^{-7}	3×10^{-3}	2×10^{-8}	1×10^{-4}
		I	6×10^{-7}	3×10^{-3}	2×10^{-8}	1×10^{-4}
	Eu 152	S	4×10^{-7}	2×10^{-3}	1×10^{-8}	6×10^{-5}
	(T/2=9.2 hrs)	I	3×10^{-7}	2×10^{-3}	1×10^{-8}	6×10^{-5}
	Eu 152	S	1×10^{-8}	2×10^{-3}	4×10^{-10}	8×10^{-5}
	(T/2=13 yrs)	I	2×10^{-8}	2×10^{-3}	6×10^{-10}	8×10^{-5}
	Eu 154	S	4×10^{-9}	6×10^{-4}	1×10^{-10}	2×10^{-5}
		I	7×10^{-9}	6×10^{-4}	2×10^{-10}	2×10^{-5}
Fluorine (9)	Eu 155	S	9×10^{-8}	6×10^{-3}	3×10^{-9}	2×10^{-4}
		I	7×10^{-8}	6×10^{-3}	3×10^{-9}	2×10^{-4}
Gadolinium (64)	F 18	S	5×10^{-6}	2×10^{-2}	2×10^{-7}	8×10^{-4}
		I	3×10^{-6}	1×10^{-2}	9×10^{-8}	5×10^{-4}
Gadolinium (64)	Gd 153	S	2×10^{-7}	6×10^{-3}	8×10^{-9}	2×10^{-4}
		I	9×10^{-8}	6×10^{-3}	3×10^{-9}	2×10^{-4}
	Gd 159	S	5×10^{-7}	2×10^{-3}	2×10^{-8}	8×10^{-5}
		I	4×10^{-7}	2×10^{-3}	1×10^{-8}	8×10^{-5}
Gallium (31)	Ga 72	S	2×10^{-7}	1×10^{-3}	8×10^{-9}	4×10^{-5}
		I	2×10^{-7}	1×10^{-3}	6×10^{-9}	4×10^{-5}
Germanium (32)	Ge 71	S	1×10^{-5}	5×10^{-2}	4×10^{-7}	2×10^{-3}
		I	6×10^{-6}	5×10^{-2}	2×10^{-7}	2×10^{-3}
Gold (79)	Au 196	S	1×10^{-6}	5×10^{-3}	4×10^{-8}	2×10^{-4}
		I	6×10^{-7}	4×10^{-3}	2×10^{-8}	1×10^{-4}
	Au 198	S	3×10^{-7}	2×10^{-3}	1×10^{-8}	5×10^{-5}
		I	2×10^{-7}	1×10^{-3}	8×10^{-9}	5×10^{-5}
	Au 199	S	1×10^{-6}	5×10^{-3}	4×10^{-8}	2×10^{-4}
Hafnium (72)		I	8×10^{-7}	4×10^{-3}	3×10^{-8}	2×10^{-4}
	Hf 181	S	4×10^{-8}	2×10^{-3}	1×10^{-9}	7×10^{-5}
Holmium (67)		I	7×10^{-8}	2×10^{-3}	3×10^{-9}	7×10^{-5}
	Ho 166	S	2×10^{-7}	9×10^{-4}	7×10^{-9}	3×10^{-5}
Hydrogen (1)		I	2×10^{-7}	9×10^{-4}	6×10^{-9}	3×10^{-5}
	H3	S	5×10^{-6}	1×10^{-1}	2×10^{-7}	3×10^{-3}
Indium (49)		Sub	2×10^{-3}	4×10^{-5}
	In 113m	S	8×10^{-6}	4×10^{-2}	3×10^{-7}	1×10^{-3}
		I	7×10^{-6}	4×10^{-2}	2×10^{-7}	1×10^{-3}
	In 114m	S	1×10^{-7}	5×10^{-4}	4×10^{-9}	2×10^{-5}
		I	2×10^{-8}	5×10^{-4}	7×10^{-10}	2×10^{-5}
	In 115m	S	2×10^{-6}	1×10^{-2}	8×10^{-8}	4×10^{-4}
		I	2×10^{-6}	1×10^{-2}	6×10^{-8}	4×10^{-4}

CONCENTRATIONS IN AIR AND WATER ABOVE NATURAL BACKGROUND-continued

(See notes at end of annex)

Element (atomic number)	Isotope ¹		Table I		Table II	
			Column 1 Air ($\mu\text{c/ml}$)	Column 2 Water ($\mu\text{c/ml}$)	Column 1 Air ($\mu\text{c/ml}$)	Column 2 Water ($\mu\text{c/ml}$)
Iodine (53)	I ¹¹⁵	S	2×10^{-7}	3×10^{-3}	9×10^{-9}	9×10^{-5}
		I	3×10^{-8}	3×10^{-3}	1×10^{-9}	9×10^{-5}
	I ¹²⁵	S	5×10^{-9}	4×10^{-5}	8×10^{-11}	2×10^{-7}
		I	2×10^{-7}	6×10^{-3}	1×10^{-9}	2×10^{-5}
	I ¹²⁹	S	2×10^{-9}	1×10^{-5}	2×10^{-11}	4×10^{-7}
		I	7×10^{-8}	6×10^{-3}	2×10^{-9}	2×10^{-4}
	I ¹³¹	S	9×10^{-9}	6×10^{-5}	1×10^{-10}	3×10^{-7}
		I	3×10^{-7}	2×10^{-3}	1×10^{-8}	6×10^{-5}
	I ¹³²	S	2×10^{-7}	2×10^{-3}	3×10^{-9}	8×10^{-6}
		I	9×10^{-7}	5×10^{-3}	3×10^{-8}	2×10^{-4}
	I ¹³³	S	3×10^{-8}	2×10^{-4}	1×10^{-10}	7×10^{-6}
		I	2×10^{-7}	1×10^{-3}	7×10^{-9}	4×10^{-5}
	I ¹³⁴	S	5×10^{-7}	4×10^{-3}	2×10^{-9}	1×10^{-5}
		I	3×10^{-6}	2×10^{-2}	1×10^{-7}	6×10^{-4}
I ¹³⁵	S	1×10^{-7}	7×10^{-4}	1×10^{-9}	2×10^{-5}	
	I	4×10^{-7}	2×10^{-3}	1×10^{-8}	7×10^{-5}	
Iridium (77)	Ir ¹⁹⁰	S	1×10^{-6}	6×10^{-3}	4×10^{-8}	2×10^{-4}
		I	4×10^{-7}	5×10^{-3}	1×10^{-8}	2×10^{-4}
	Ir ¹⁹²	S	1×10^{-7}	1×10^{-3}	4×10^{-9}	4×10^{-5}
		I	3×10^{-8}	1×10^{-3}	9×10^{-10}	4×10^{-5}
Ir ¹⁹⁴	S	2×10^{-7}	1×10^{-3}	8×10^{-9}	3×10^{-5}	
	I	2×10^{-7}	9×10^{-4}	5×10^{-9}	3×10^{-5}	
Iron (26)	Fe ⁵⁵	S	9×10^{-7}	2×10^{-2}	3×10^{-8}	8×10^{-4}
		I	1×10^{-6}	7×10^{-2}	3×10^{-8}	2×10^{-3}
	Fe ⁵⁹	S	1×10^{-7}	2×10^{-3}	5×10^{-9}	6×10^{-5}
		I	5×10^{-8}	2×10^{-3}	2×10^{-9}	5×10^{-5}
Krypton (36)	Kr ^{85m}	Sub	6×10^{-6}	1×10^{-7}
	Kr ⁸⁵	Sub	1×10^{-5}	3×10^{-8}
	Kr ⁸⁷	Sub	1×10^{-6}	2×10^{-8}
Lanthanum (57)	La ¹⁴⁰	S	2×10^{-7}	7×10^{-4}	5×10^{-9}	2×10^{-5}
		I	1×10^{-7}	7×10^{-4}	4×10^{-9}	2×10^{-5}
Lead (82)	Pb ²⁰³	S	3×10^{-6}	1×10^{-2}	9×10^{-8}	4×10^{-4}
		I	2×10^{-6}	1×10^{-2}	6×10^{-8}	4×10^{-4}
	Pb ²¹⁰	S	1×10^{-10}	4×10^{-6}	4×10^{-12}	1×10^{-7}
		I	2×10^{-10}	5×10^{-3}	8×10^{-12}	2×10^{-4}
	Pb ²¹²	S	2×10^{-8}	6×10^{-4}	6×10^{-10}	2×10^{-5}
		I	2×10^{-8}	5×10^{-4}	7×10^{-10}	2×10^{-5}

CONCENTRATIONS IN AIR AND WATER ABOVE NATURAL BACKGROUND—continued

(See notes at end of annex)

Element (atomic number)	Isotope ¹		Table I		Table II	
			Column 1 Air ($\mu\text{c}/\text{ml}$)	Column 2 Water ($\mu\text{c}/\text{ml}$)	Column 1 Air ($\mu\text{c}/\text{ml}$)	Column 2 Water ($\mu\text{c}/\text{ml}$)
Lutetium (71)	Lu 177	S	6×10^{-7}	3×10^{-3}	2×10^{-8}	1×10^{-4}
		I	5×10^{-7}	3×10^{-3}	2×10^{-8}	1×10^{-4}
Manganese (25)	Mn 52	S	2×10^{-7}	1×10^{-3}	7×10^{-9}	3×10^{-5}
		I	1×10^{-7}	9×10^{-4}	5×10^{-9}	3×10^{-5}
	Mn 54	S	4×10^{-7}	4×10^{-3}	1×10^{-9}	1×10^{-4}
		I	4×10^{-8}	3×10^{-3}	1×10^{-9}	1×10^{-4}
Mn 56	S	8×10^{-7}	4×10^{-3}	3×10^{-8}	1×10^{-4}	
	I	5×10^{-7}	3×10^{-3}	2×10^{-8}	1×10^{-4}	
Mercury (80)	Hg 197m	S	7×10^{-7}	6×10^{-3}	3×10^{-8}	2×10^{-4}
		I	8×10^{-7}	5×10^{-3}	3×10^{-8}	2×10^{-4}
	Hg 197	S	1×10^{-6}	9×10^{-3}	4×10^{-8}	3×10^{-4}
		I	3×10^{-6}	1×10^{-2}	9×10^{-8}	5×10^{-4}
	Hg 203	S	7×10^{-7}	5×10^{-3}	2×10^{-9}	2×10^{-5}
		I	1×10^{-7}	3×10^{-3}	4×10^{-9}	1×10^{-4}
Molybdenum (42)	Mo 99	S	7×10^{-7}	5×10^{-3}	3×10^{-8}	2×10^{-4}
		I	2×10^{-7}	1×10^{-3}	7×10^{-9}	4×10^{-5}
Neodymium (60)	Nd 144	S	8×10^{-11}	2×10^{-3}	3×10^{-12}	7×10^{-5}
		I	3×10^{-10}	2×10^{-3}	1×10^{-11}	8×10^{-5}
	Nd 147	S	4×10^{-7}	2×10^{-3}	1×10^{-8}	6×10^{-5}
		I	2×10^{-7}	2×10^{-3}	8×10^{-9}	6×10^{-5}
	Nd 149	S	2×10^{-6}	8×10^{-3}	6×10^{-8}	3×10^{-4}
I	1×10^{-6}	8×10^{-3}	5×10^{-8}	3×10^{-4}		
Neptunium (93)	Np 237	S	4×10^{-12}	9×10^{-5}	1×10^{-13}	3×10^{-6}
		I	1×10^{-10}	9×10^{-4}	4×10^{-12}	3×10^{-5}
	Np 239	S	8×10^{-7}	4×10^{-3}	3×10^{-8}	1×10^{-4}
Nickel (28)	Ni 59	S	7×10^{-7}	4×10^{-3}	2×10^{-8}	1×10^{-4}
		I	5×10^{-7}	6×10^{-3}	2×10^{-8}	2×10^{-4}
	Ni 63	S	8×10^{-8}	6×10^{-2}	3×10^{-8}	2×10^{-3}
		I	6×10^{-8}	8×10^{-4}	2×10^{-9}	3×10^{-5}
	Ni 65	S	3×10^{-7}	2×10^{-2}	1×10^{-8}	7×10^{-4}
		I	9×10^{-7}	4×10^{-3}	3×10^{-8}	1×10^{-4}
Niobium (Columbium)(41)..	Nb 93m	S	5×10^{-7}	3×10^{-3}	2×10^{-8}	1×10^{-4}
		I	1×10^{-7}	1×10^{-2}	4×10^{-9}	4×10^{-4}
	Nb 95	S	2×10^{-7}	1×10^{-2}	5×10^{-9}	4×10^{-4}
		I	5×10^{-7}	3×10^{-3}	2×10^{-8}	1×10^{-4}
	Nb 97	S	1×10^{-7}	3×10^{-3}	3×10^{-9}	1×10^{-4}
		I	6×10^{-6}	3×10^{-2}	2×10^{-7}	9×10^{-4}
I	5×10^{-6}	3×10^{-2}	2×10^{-7}	9×10^{-4}		

CONCENTRATIONS IN AIR AND WATER ABOVE NATURAL BACKGROUND-continued

(See notes at end of annex)

Element (atomic number)	Isotope ¹		Table I		Table II		
			Column 1 Air ($\mu\text{c/ml}$)	Column 2 Water ($\mu\text{c/ml}$)	Column 1 Air ($\mu\text{c/ml}$)	Column 2 Water ($\mu\text{c/ml}$)	
Osmium (76)	Os 185	S	5×10^{-7}	2×10^{-3}	2×10^{-8}	7×10^{-5}	
		I	5×10^{-8}	2×10^{-3}	2×10^{-9}	7×10^{-5}	
	Os 191m	S	2×10^{-5}	7×10^{-2}	6×10^{-7}	3×10^{-3}	
		I	9×10^{-6}	7×10^{-2}	3×10^{-7}	2×10^{-3}	
	Os 191	S	1×10^{-6}	5×10^{-3}	4×10^{-8}	2×10^{-4}	
		I	4×10^{-7}	5×10^{-3}	1×10^{-8}	2×10^{-4}	
	Os 193	S	4×10^{-7}	2×10^{-3}	1×10^{-8}	6×10^{-5}	
		I	3×10^{-7}	2×10^{-3}	9×10^{-9}	5×10^{-5}	
Palladium (46)	Pd 103	S	1×10^{-6}	1×10^{-2}	5×10^{-8}	3×10^{-4}	
		I	7×10^{-7}	8×10^{-3}	3×10^{-8}	3×10^{-4}	
	Pd 109	S	6×10^{-7}	3×10^{-3}	2×10^{-8}	9×10^{-5}	
		I	4×10^{-7}	2×10^{-3}	1×10^{-8}	7×10^{-5}	
Phosphorus (15)	P 32	S	7×10^{-8}	9×10^{-4}	2×10^{-9}	2×10^{-5}	
		I	8×10^{-8}	7×10^{-4}	3×10^{-9}	2×10^{-5}	
	Platinum (78)	Pt 191	S	8×10^{-7}	4×10^{-3}	3×10^{-8}	1×10^{-4}
			I	6×10^{-7}	3×10^{-3}	2×10^{-8}	1×10^{-4}
Platinum (78)	Pt 193m	S	7×10^{-6}	3×10^{-2}	2×10^{-7}	1×10^{-3}	
		I	5×10^{-6}	3×10^{-2}	2×10^{-7}	1×10^{-3}	
	Pt 197m	S	6×10^{-6}	3×10^{-2}	2×10^{-7}	1×10^{-3}	
		I	5×10^{-6}	3×10^{-2}	2×10^{-7}	9×10^{-4}	
	Pt 197	S	8×10^{-7}	4×10^{-3}	3×10^{-8}	1×10^{-4}	
		I	6×10^{-7}	3×10^{-3}	2×10^{-8}	1×10^{-4}	
Plutonium (94)	Pu 238	S	2×10^{-12}	1×10^{-4}	7×10^{-14}	5×10^{-6}	
		I	3×10^{-11}	8×10^{-4}	1×10^{-12}	3×10^{-5}	
	Pu 239	S	2×10^{-12}	1×10^{-4}	6×10^{-14}	5×10^{-6}	
		I	4×10^{-11}	8×10^{-4}	1×10^{-12}	3×10^{-5}	
	Pu 240	S	2×10^{-12}	1×10^{-4}	6×10^{-14}	5×10^{-6}	
		I	4×10^{-11}	8×10^{-4}	1×10^{-12}	3×10^{-5}	
	Pu 241	S	9×10^{-11}	7×10^{-3}	3×10^{-12}	2×10^{-4}	
		I	4×10^{-8}	4×10^{-2}	1×10^{-9}	1×10^{-3}	
	Pu 242	S	2×10^{-12}	1×10^{-4}	6×10^{-14}	5×10^{-6}	
		I	4×10^{-11}	9×10^{-4}	1×10^{-12}	3×10^{-5}	
	Polonium (84)	Po 210	S	5×10^{-10}	2×10^{-5}	2×10^{-11}	7×10^{-7}
			I	2×10^{-10}	8×10^{-4}	7×10^{-12}	3×10^{-5}
Potassium (19)	K42	S	2×10^{-6}	9×10^{-3}	7×10^{-8}	3×10^{-4}	
		I	1×10^{-7}	6×10^{-4}	4×10^{-9}	2×10^{-5}	
Praseodymium (59)	Pr 142	S	2×10^{-7}	9×10^{-4}	7×10^{-9}	3×10^{-5}	
		I	2×10^{-7}	9×10^{-4}	5×10^{-9}	3×10^{-5}	

CONCENTRATIONS IN AIR AND WATER ABOVE NATURAL BACKGROUND-continued

(See notes at end of annex)

Element (atomic number)	Isotope ¹	Table I		Table II		
		Column 1 Air ($\mu\text{c}/\text{ml}$)	Column 2 Water ($\mu\text{c}/\text{ml}$)	Column 1 Air ($\mu\text{c}/\text{ml}$)	Column 2 Water ($\mu\text{c}/\text{ml}$)	
Promethium (61)	Pr 143	S	3×10^{-7}	1×10^{-3}	1×10^{-8}	5×10^{-5}
		I	2×10^{-7}	1×10^{-3}	6×10^{-9}	5×10^{-5}
	Pm 147	S	6×10^{-8}	6×10^{-3}	2×10^{-9}	2×10^{-4}
		I	1×10^{-7}	6×10^{-3}	3×10^{-9}	2×10^{-4}
	Pm 149	S	3×10^{-7}	1×10^{-3}	1×10^{-8}	4×10^{-5}
Protoactinium (91)		I	2×10^{-7}	1×10^{-3}	8×10^{-9}	4×10^{-5}
	Pa 230	S	2×10^{-9}	7×10^{-3}	6×10^{-11}	2×10^{-4}
		I	8×10^{-10}	7×10^{-3}	3×10^{-11}	2×10^{-4}
	Pa 231	S	1×10^{-12}	3×10^{-5}	4×10^{-14}	9×10^{-7}
		I	1×10^{-10}	8×10^{-4}	4×10^{-12}	2×10^{-5}
Radium (88)	Pa 233	S	6×10^{-7}	4×10^{-3}	2×10^{-8}	1×10^{-4}
		I	2×10^{-7}	3×10^{-3}	6×10^{-9}	1×10^{-4}
	Ra 223	S	2×10^{-9}	2×10^{-5}	6×10^{-11}	7×10^{-7}
		I	2×10^{-10}	1×10^{-4}	8×10^{-12}	4×10^{-6}
	Ra 224	S	5×10^{-9}	7×10^{-5}	2×10^{-10}	2×10^{-6}
Radon (86)		I	7×10^{-10}	2×10^{-4}	2×10^{-11}	5×10^{-6}
	Ra 226	S	3×10^{-11}	4×10^{-7}	3×10^{-12}	3×10^{-8}
		I	5×10^{-11}	9×10^{-4}	2×10^{-12}	3×10^{-5}
	Ra 228	S	7×10^{-11}	8×10^{-7}	2×10^{-12}	3×10^{-8}
		I	4×10^{-11}	7×10^{-4}	1×10^{-12}	3×10^{-5}
Rhenium (75)	Rn 220	S	3×10^{-7}	1×10^{-8}
	Rn 222		1×10^{-7}	3×10^{-9}
Rhodium (45)	Re 183	S	3×10^{-6}	2×10^{-2}	9×10^{-8}	6×10^{-4}
		I	2×10^{-7}	8×10^{-3}	5×10^{-9}	3×10^{-4}
	Re 186	S	6×10^{-7}	3×10^{-3}	2×10^{-8}	9×10^{-5}
		I	2×10^{-7}	1×10^{-3}	8×10^{-9}	5×10^{-5}
	Re 187	S	9×10^{-6}	7×10^{-2}	3×10^{-7}	3×10^{-3}
Rubidium (37)		I	5×10^{-7}	4×10^{-2}	2×10^{-8}	2×10^{-3}
	Re 188	S	4×10^{-7}	2×10^{-3}	1×10^{-8}	6×10^{-5}
		I	2×10^{-7}	9×10^{-4}	6×10^{-9}	3×10^{-5}
	Rh 103m	S	8×10^{-5}	4×10^{-1}	3×10^{-6}	1×10^{-2}
		I	6×10^{-5}	3×10^{-1}	2×10^{-6}	1×10^{-2}
Rhodium (45)	Rh 105	S	8×10^{-7}	4×10^{-3}	3×10^{-8}	1×10^{-4}
		I	5×10^{-7}	3×10^{-3}	2×10^{-8}	1×10^{-4}
	Rb 86	S	3×10^{-7}	2×10^{-3}	1×10^{-8}	7×10^{-5}
Rubidium (37)		I	7×10^{-8}	7×10^{-4}	2×10^{-9}	2×10^{-5}
	Rb 87	S	5×10^{-7}	3×10^{-3}	2×10^{-8}	1×10^{-4}
		I	7×10^{-8}	5×10^{-3}	2×10^{-9}	2×10^{-4}

CONCENTRATIONS IN AIR AND WATER ABOVE NATURAL BACKGROUND-continued

(See notes at end of annex)

Element (atomic number)	Isotope ¹		Table I		Table II	
			Column 1 Air ($\mu\text{c/ml}$)	Column 2 Water ($\mu\text{c/ml}$)	Column 1 Air ($\mu\text{c/ml}$)	Column 2 Water ($\mu\text{c/ml}$)
Ruthenium (44)	Ru 97	S	2×10^{-6}	1×10^{-2}	8×10^{-8}	4×10^{-4}
		I	2×10^{-6}	1×10^{-2}	6×10^{-8}	3×10^{-4}
	Ru 103	S	5×10^{-7}	2×10^{-3}	2×10^{-8}	8×10^{-5}
		I	8×10^{-8}	2×10^{-3}	3×10^{-9}	8×10^{-5}
	Ru 105	S	7×10^{-7}	3×10^{-3}	2×10^{-8}	1×10^{-4}
		I	5×10^{-7}	3×10^{-3}	2×10^{-8}	1×10^{-4}
	Ru 106	S	8×10^{-8}	4×10^{-4}	3×10^{-9}	1×10^{-5}
		I	6×10^{-9}	3×10^{-4}	2×10^{-10}	1×10^{-5}
Samarium (62)	Sm 147	S	7×10^{-11}	2×10^{-5}	2×10^{-12}	6×10^{-5}
		I	3×10^{-10}	2×10^{-5}	9×10^{-12}	7×10^{-5}
	Sm 151	S	6×10^{-8}	1×10^{-2}	2×10^{-9}	4×10^{-4}
		I	1×10^{-7}	1×10^{-2}	5×10^{-9}	4×10^{-4}
	Sm 153	S	5×10^{-7}	2×10^{-3}	2×10^{-8}	8×10^{-5}
		I	4×10^{-7}	2×10^{-3}	1×10^{-8}	8×10^{-5}
Scandium (21)	Sc 46	S	2×10^{-7}	1×10^{-3}	8×10^{-9}	4×10^{-5}
		I	2×10^{-8}	1×10^{-3}	8×10^{-10}	4×10^{-5}
	Sc 47	S	6×10^{-7}	3×10^{-3}	2×10^{-8}	9×10^{-5}
		I	5×10^{-7}	3×10^{-3}	2×10^{-8}	9×10^{-5}
	Sc 48	S	2×10^{-7}	8×10^{-4}	6×10^{-9}	3×10^{-5}
		I	1×10^{-7}	8×10^{-4}	5×10^{-9}	3×10^{-5}
Selenium (34)	Se 75	S	1×10^{-6}	9×10^{-3}	4×10^{-8}	3×10^{-4}
		I	1×10^{-7}	8×10^{-3}	4×10^{-9}	3×10^{-4}
Silicon (14)	Si 31	S	6×10^{-6}	3×10^{-2}	2×10^{-7}	9×10^{-4}
		I	1×10^{-6}	6×10^{-3}	3×10^{-8}	2×10^{-4}
Silver (47)	Ag 105	S	6×10^{-7}	3×10^{-3}	2×10^{-8}	1×10^{-4}
		I	8×10^{-8}	3×10^{-3}	3×10^{-9}	1×10^{-4}
	Ag 110m	S	2×10^{-7}	9×10^{-4}	7×10^{-9}	3×10^{-5}
		I	1×10^{-8}	9×10^{-4}	3×10^{-10}	3×10^{-5}
	Ag 111	S	3×10^{-7}	1×10^{-3}	1×10^{-8}	4×10^{-5}
		I	2×10^{-7}	1×10^{-3}	8×10^{-9}	4×10^{-5}
Sodium (11)	Na 22	S	2×10^{-7}	1×10^{-3}	6×10^{-9}	4×10^{-5}
		I	9×10^{-9}	9×10^{-4}	3×10^{-10}	3×10^{-5}
	Na 24	S	1×10^{-6}	6×10^{-3}	4×10^{-8}	2×10^{-4}
		I	1×10^{-7}	8×10^{-4}	5×10^{-9}	3×10^{-5}
Strontium (38)	Sr 85m	S	4×10^{-5}	2×10^{-1}	1×10^{-6}	7×10^{-3}
		I	3×10^{-5}	2×10^{-1}	1×10^{-6}	7×10^{-3}
	Sr 85	S	2×10^{-7}	3×10^{-3}	8×10^{-9}	1×10^{-4}
		I	1×10^{-7}	5×10^{-3}	4×10^{-9}	2×10^{-4}

CONCENTRATIONS IN AIR AND WATER ABOVE NATURAL BACKGROUND-continued

(See notes at end of annex)

Element (atomic number)	Isotope ¹		Table I		Table II	
			Column 1 Air ($\mu\text{c}/\text{ml}$)	Column 2 Water ($\mu\text{c}/\text{ml}$)	Column 1 Air ($\mu\text{c}/\text{ml}$)	Column 2 Water ($\mu\text{c}/\text{ml}$)
	Sr 89	S	3×10^{-8}	3×10^{-4}	3×10^{-10}	3×10^{-6}
		I	4×10^{-8}	8×10^{-4}	1×10^{-9}	3×10^{-5}
	Sr 90	S	3×10^{-10}	1×10^{-5}	3×10^{-11}	3×10^{-7}
		I	5×10^{-9}	1×10^{-3}	2×10^{-10}	4×10^{-5}
	Sr 91	S	4×10^{-7}	2×10^{-3}	2×10^{-8}	7×10^{-5}
		I	3×10^{-7}	1×10^{-3}	9×10^{-9}	5×10^{-5}
	Sr 92	S	4×10^{-7}	2×10^{-3}	2×10^{-8}	7×10^{-5}
		I	3×10^{-7}	2×10^{-3}	1×10^{-8}	6×10^{-5}
Sulfur (16)	S 35	S	3×10^{-7}	2×10^{-3}	9×10^{-9}	6×10^{-5}
		I	3×10^{-7}	8×10^{-3}	9×10^{-9}	3×10^{-4}
Tantalum (73)	Ta 182	S	4×10^{-8}	1×10^{-3}	1×10^{-9}	4×10^{-5}
		I	2×10^{-8}	1×10^{-3}	7×10^{-10}	4×10^{-5}
Technetium (43)	Tc 96m	S	8×10^{-5}	4×10^{-1}	3×10^{-6}	1×10^{-3}
		I	3×10^{-5}	3×10^{-1}	1×10^{-6}	1×10^{-2}
	Tc 96	S	6×10^{-7}	3×10^{-3}	2×10^{-8}	1×10^{-4}
		I	2×10^{-7}	1×10^{-3}	8×10^{-9}	5×10^{-5}
	Tc 97m	S	2×10^{-6}	1×10^{-2}	8×10^{-8}	4×10^{-4}
		I	2×10^{-7}	5×10^{-3}	5×10^{-9}	2×10^{-4}
	Tc 97	S	1×10^{-5}	5×10^{-2}	4×10^{-7}	2×10^{-3}
		I	3×10^{-7}	2×10^{-2}	1×10^{-8}	8×10^{-4}
	Tc 99m	S	4×10^{-5}	2×10^{-1}	1×10^{-6}	6×10^{-3}
		I	1×10^{-5}	8×10^{-2}	5×10^{-7}	3×10^{-3}
	Tc 99	S	2×10^{-6}	1×10^{-2}	7×10^{-8}	3×10^{-4}
		I	6×10^{-8}	5×10^{-3}	2×10^{-9}	2×10^{-4}
Tellurium (52)	Te 125m	S	4×10^{-7}	5×10^{-3}	1×10^{-8}	2×10^{-4}
		I	4×10^{-8}	2×10^{-3}	1×10^{-9}	5×10^{-5}
	Te 127	S	2×10^{-6}	8×10^{-3}	6×10^{-8}	3×10^{-4}
		I	9×10^{-7}	5×10^{-3}	3×10^{-8}	2×10^{-4}
	Te 129m	S	8×10^{-8}	1×10^{-3}	3×10^{-9}	3×10^{-5}
		I	3×10^{-8}	6×10^{-4}	1×10^{-9}	2×10^{-5}
	Te 129	S	5×10^{-6}	2×10^{-2}	2×10^{-7}	8×10^{-4}
		I	4×10^{-6}	2×10^{-2}	1×10^{-7}	8×10^{-4}
	Te 131m	S	4×10^{-7}	2×10^{-3}	1×10^{-8}	6×10^{-5}
		I	2×10^{-7}	1×10^{-3}	6×10^{-9}	4×10^{-5}
	Te 132	S	2×10^{-7}	9×10^{-4}	7×10^{-9}	3×10^{-5}
		I	1×10^{-7}	6×10^{-4}	4×10^{-9}	2×10^{-5}

CONCENTRATIONS IN AIR AND WATER ABOVE NATURAL BACKGROUND-continued

(See notes at end of annex)

Element (atomic number)	Isotope ¹		Table I		Table II		
			Column 1 Air ($\mu\text{c}/\text{ml}$)	Column 2 Water ($\mu\text{c}/\text{ml}$)	Column 1 Air ($\mu\text{c}/\text{ml}$)	Column 2 Water ($\mu\text{c}/\text{ml}$)	
Terbium (65)	Tb 160	S	1×10^{-7}	1×10^{-3}	3×10^{-9}	4×10^{-5}	
		I	3×10^{-8}	1×10^{-3}	1×10^{-9}	4×10^{-5}	
Thallium (81)	Tl 200	S	3×10^{-6}	1×10^{-2}	9×10^{-8}	4×10^{-4}	
		I	1×10^{-6}	7×10^{-3}	4×10^{-8}	2×10^{-4}	
	Tl 201	S	2×10^{-6}	9×10^{-3}	7×10^{-8}	3×10^{-4}	
		I	9×10^{-7}	5×10^{-3}	3×10^{-8}	2×10^{-4}	
	Tl 202	S	8×10^{-7}	4×10^{-3}	3×10^{-8}	1×10^{-4}	
		I	2×10^{-7}	2×10^{-3}	8×10^{-9}	7×10^{-5}	
Thorium (90)	Th 204	S	6×10^{-7}	3×10^{-3}	2×10^{-8}	1×10^{-4}	
		I	3×10^{-8}	2×10^{-3}	9×10^{-10}	6×10^{-5}	
	Th 228	S	9×10^{-12}	2×10^{-4}	3×10^{-13}	7×10^{-6}	
		I	6×10^{-12}	4×10^{-4}	2×10^{-13}	10^{-5}	
	Th 230	S	2×10^{-12}	5×10^{-5}	8×10^{-14}	2×10^{-6}	
		I	10^{-11}	9×10^{-4}	3×10^{-13}	3×10^{-5}	
Th 232	S	3×10^{-11}	5×10^{-5}	10^{-12}	2×10^{-6}		
	I	3×10^{-11}	10^{-3}	10^{-12}	4×10^{-5}		
Thulium (69)	Tm 170	S	4×10^{-8}	1×10^{-3}	1×10^{-9}	5×10^{-5}	
		I	3×10^{-8}	1×10^{-3}	1×10^{-9}	5×10^{-5}	
	Tm 171	S	1×10^{-7}	1×10^{-2}	4×10^{-9}	5×10^{-4}	
		I	2×10^{-7}	1×10^{-2}	8×10^{-9}	5×10^{-4}	
	Tin (50)	Sn 113	S	4×10^{-7}	2×10^{-3}	1×10^{-8}	9×10^{-5}
			I	5×10^{-8}	2×10^{-3}	2×10^{-9}	8×10^{-5}
Sn 125		S	1×10^{-7}	5×10^{-4}	4×10^{-9}	2×10^{-5}	
		I	8×10^{-8}	5×10^{-4}	3×10^{-9}	2×10^{-5}	
Tungsten (Wolfram)(74) ..		W 181	S	2×10^{-6}	1×10^{-2}	8×10^{-8}	4×10^{-4}
			I	1×10^{-7}	1×10^{-2}	4×10^{-9}	3×10^{-4}
	W 185	S	8×10^{-7}	4×10^{-3}	3×10^{-8}	1×10^{-4}	
		I	1×10^{-7}	3×10^{-3}	4×10^{-9}	1×10^{-4}	
	W 187	S	4×10^{-7}	2×10^{-3}	2×10^{-8}	7×10^{-5}	
		I	3×10^{-7}	2×10^{-3}	1×10^{-8}	6×10^{-5}	
Uranium (92)	U 230	S	3×10^{-10}	1×10^{-4}	1×10^{-11}	5×10^{-6}	
		I	1×10^{-10}	1×10^{-4}	4×10^{-12}	5×10^{-6}	
	U 232	S	1×10^{-10}	8×10^{-4}	3×10^{-12}	3×10^{-5}	
		I	3×10^{-11}	8×10^{-4}	9×10^{-13}	3×10^{-5}	

CONCENTRATIONS IN AIR AND WATER ABOVE NATURAL BACKGROUND-continued

(See notes at end of annex)

Element (atomic number)	Isotope ¹		Table I		Table II	
			Column 1 Air ($\mu\text{c}/\text{ml}$)	Column 2 Water ($\mu\text{c}/\text{ml}$)	Column 1 Air ($\mu\text{c}/\text{ml}$)	Column 2 Water ($\mu\text{c}/\text{ml}$)
	U 233	S	5×10^{-10}	9×10^{-4}	2×10^{-11}	3×10^{-5}
		I	1×10^{-10}	9×10^{-4}	4×10^{-12}	3×10^{-5}
	U 234	S	6×10^{-10}	9×10^{-4}	2×10^{-11}	3×10^{-5}
		I	1×10^{-10}	9×10^{-4}	4×10^{-12}	3×10^{-5}
	U 235	S	5×10^{-10}	8×10^{-4}	2×10^{-11}	3×10^{-5}
		I	1×10^{-10}	8×10^{-4}	4×10^{-12}	3×10^{-5}
	U 236	S	6×10^{-10}	1×10^{-3}	2×10^{-11}	3×10^{-5}
		I	1×10^{-10}	1×10^{-3}	4×10^{-12}	3×10^{-5}
	U 238	S	7×10^{-11}	1×10^{-3}	3×10^{-12}	4×10^{-5}
		I	1×10^{-10}	1×10^{-3}	5×10^{-12}	4×10^{-5}
U-natural	S	7×10^{-10}	1×10^{-3}	3×10^{-12}	2×10^{-5}	
	I	6×10^{-10}	1×10^{-3}	2×10^{-12}	3×10^{-5}	
Vanadium (23)	V 48	S	2×10^{-7}	9×10^{-4}	6×10^{-9}	3×10^{-5}
		I	6×10^{-8}	8×10^{-4}	2×10^{-9}	3×10^{-5}
Xenon (54)	Xe 131m	Sub	2×10^{-5}	4×10^{-7}
	Xe 133	Sub	1×10^{-5}	3×10^{-7}
	Xe 135	Sub	4×10^{-6}	1×10^{-7}
Ytterbium (70)	Yb 175	S	7×10^{-7}	3×10^{-3}	2×10^{-8}	1×10^{-4}
		I	6×10^{-7}	3×10^{-3}	2×10^{-8}	1×10^{-4}
Yttrium (39)	Y 90	S	1×10^{-7}	6×10^{-4}	4×10^{-9}	2×10^{-5}
		I	1×10^{-7}	6×10^{-4}	3×10^{-9}	2×10^{-5}
	Y 91m	S	2×10^{-5}	1×10^{-1}	8×10^{-7}	3×10^{-3}
		I	2×10^{-5}	1×10^{-1}	6×10^{-7}	3×10^{-3}
	Y 91	S	4×10^{-8}	8×10^{-4}	1×10^{-9}	3×10^{-5}
		I	3×10^{-8}	8×10^{-4}	1×10^{-9}	3×10^{-5}
	Y 92	S	4×10^{-7}	2×10^{-3}	1×10^{-8}	6×10^{-5}
		I	3×10^{-7}	2×10^{-3}	1×10^{-8}	6×10^{-5}
	Y 93	S	2×10^{-7}	8×10^{-4}	6×10^{-9}	3×10^{-5}
		I	1×10^{-7}	8×10^{-4}	5×10^{-9}	3×10^{-5}
Zinc (30)	Zn 65	S	1×10^{-7}	3×10^{-3}	4×10^{-9}	1×10^{-4}
		I	6×10^{-8}	5×10^{-3}	2×10^{-9}	2×10^{-4}
	Zn 69m	S	4×10^{-7}	2×10^{-3}	1×10^{-8}	7×10^{-5}
		I	3×10^{-7}	2×10^{-3}	1×10^{-8}	6×10^{-5}
	Zn 69	S	7×10^{-6}	5×10^{-2}	2×10^{-7}	2×10^{-3}
		I	9×10^{-6}	5×10^{-2}	3×10^{-7}	2×10^{-3}
Zirconium (40)	Zr 93	S	1×10^{-7}	2×10^{-2}	4×10^{-9}	8×10^{-4}
		I	3×10^{-7}	2×10^{-2}	1×10^{-8}	8×10^{-4}

CONCENTRATIONS IN AIR AND WATER ABOVE NATURAL BACKGROUND-continued

(See notes at end of annex)

Element (atomic number)	Isotope ¹		Table I		Table II	
			Column 1 Air ($\mu\text{C}/\text{ml}$)	Column 2 Water ($\mu\text{C}/\text{ml}$)	Column 1 Air ($\mu\text{C}/\text{ml}$)	Column 2 Water ($\mu\text{C}/\text{ml}$)
	Zr 95	S	1×10^{-7}	2×10^{-3}	4×10^{-9}	6×10^{-5}
		I	3×10^{-8}	2×10^{-3}	1×10^{-9}	6×10^{-5}
	Zr 97	S	1×10^{-7}	5×10^{-4}	4×10^{-9}	2×10^{-5}
		I	9×10^{-8}	5×10^{-4}	3×10^{-9}	2×10^{-5}

¹Soluble (S); Insoluble (I).²"Sub" means that values given are for submersion in an infinite cloud of gaseous material.

NOTE: In any case where there is a mixture in air or water of more than one radionuclide, the limiting values for purposes of this Annex should be determined as follows:

1. If the identity and concentration of each radionuclide in the mixture are known, the limiting values should be derived as follows:

Determine, for each radionuclide mixture, the ratio between the quantity present in the mixture and the limit otherwise established in Annex I for the specific radionuclide when not in a mixture. The sum of such ratios for all the radionuclides in the mixture may not exceed "1" (i.e., "unity").

EXAMPLE: If radionuclides A, B, and C are present in concentrations C_A , C_B , and C_C , and if the applicable MPC's, are MPC_A , MPC_B , and MPC_C respectively, then the concentrations shall be limited so that the following relationship exists:

$$\frac{C_A}{MPC_A} + \frac{C_B}{MPC_B} + \frac{C_C}{MPC_C} \leq 1$$

2. If either the identity of the concentration of any radionuclide in the mixture is not known,

the limiting values for purposes of Annex I shall be:

- For purposes of Table I, Col. 1-1 $\times 10^{-12}$
- For purposes of Table I, Col. 2-3 $\times 10^{-7}$
- For purposes of Table II, Col. 1-4 $\times 10^{-14}$
- For purposes of Table II, Col. 2-1 $\times 10^{-5}$

3. If any of the conditions specified below are met, the corresponding values specified below may be used in lieu of those specified in paragraph 2 above.

a. If the identity of each radionuclide in the mixture is known but the concentration of one or more of the radionuclides in the mixture is not known, the concentration limit for the mixture is the limit specified in Annex I for the radionuclide in the mixture having the lowest concentration limit; or

b. If the identity of each radionuclide in the mixture is not known, but it is known that certain radionuclides specified in Annex I are not present in the mixture, the concentration limit for the mixture is the lowest concentration limit specified in Annex I for any radionuclide which is not known to be absent from the mixture; or

c. Element (atomic number) and isotope	Table I		Table II	
	Column 1 Air ($\mu\text{c/ml}$)	Column 2 Water ($\mu\text{c/ml}$)	Column 1 Air ($\mu\text{c/ml}$)	Column 2 Water ($\mu\text{c/ml}$)
If it is known that Sr 90, I 129, Pb 210, Po 210, At 211, Ra 223, Ra 224, Ra 226, Ac 227, Ra 228, Th 230, Pa 231, Th 232, and Th-nat, are not present.....	9×10^{-5}	3×10^{-6}
If it is known that Sr 90, I 129, Pb 210, Po 210, Ra 223, Ra 226, Ra 228, Ra 231, and Th-nat, are not present.....	6×10^{-5}	2×10^{-6}
If it is known that Sr 90, Pb 210, Ra 226, Ra 228, are not present.....	2×10^{-5}	6×10^{-7}
If it is known Ra 226 and Ra 228, are not present.....	3×10^{-6}	1×10^{-7}
If it is known that alpha-emitters and Sr 90, I 129, Pb 210, Ac 227, Ra 228, Pa 230, Pu 241, and Bk 249 are not present.....	3×10^{-9}	1×10^{-10}
If it is known that alpha-emitters and Pb 210, Ac 227, Ra 228 and Pu 241, are not present.....	3×10^{-10}	1×10^{-11}
If it is known that alpha-emitters and Ac 227 are not present.....	3×10^{-11}	1×10^{-12}
If it is known that Ac 227, Th 230, Pa 231, Pu 238, Pu 239, Pu 240, Pu 242, and Cf 249, are not present.....	3×10^{-12}	1×10^{-13}
If Pa 231, Pu 239, Pu 240, Pu 242 and Cf 249 are not present.	2×10^{-12}	7×10^{-14}

4. If the mixture of radionuclides consists of uranium and its daughter products in ore dust prior to chemical processing of the uranium ore, the values specified below may be used in lieu of those determined in accordance with paragraph 1 above or those specified in paragraphs 2 and 3 above.

a. For purposes of Table I, Col. 1-1 $\times 10^{-10}$ $\mu\text{c/ml}$ gross alpha activity; or 2.5×10^{-11} $\mu\text{c/ml}$ natural uranium; or 75 micrograms per cubic meter or air natural uranium.

b. For purposes of Table II, Col. 1-3 $\times 10^{-13}$ $\mu\text{c/ml}$ gross alpha activity; or 8×10^{-13} $\mu\text{c/ml}$ natural uranium; or 3 micrograms per cubic meter of air natural uranium.

5. For purposes of this note, a radionuclide may be considered as not present in a mixture if (a) the ratio of the concentration of that radionuclide in the mixture (C_A) to the concentration limit for that radionuclide specified in Table II of Annex I (MPC_A) does not exceed 1/10,

$$\text{i.e. } \frac{C_A}{MPC_A} \leq \frac{1}{10}$$

and (b) the sum of such ratios for all the radionuclides considered as not present in the mixture does not exceed 1/4.

$$\text{i.e. } \frac{C_A}{MPC_A} + \frac{C_B}{MPC_B} + \dots \leq \frac{1}{4}$$

APPENDIX E

U.S. ATOMIC ENERGY COMMISSION STANDARD OPERATING PROCEDURE NEVADA TEST SITE ORGANIZATION

NTSO-0101-01

CHAPTER 0101 THE NEVADA TEST SITE ORGANIZATION (NTSO)

0101-01 General

011 The Nevada Test Site

The Nevada Test Site (NTS) is a facility provided by the Atomic Energy Commission and managed by the AEC Nevada Operations Office (NV). The NTS supports the field test programs of the AEC and its contractors, the Department of Defense, and others authorized to be conducted at the NTS.

012 The Nevada Test Site Organization (NTSO)

The Nevada Test Site Organization (NTSO) includes AEC, DOD, Laboratory, contractor, agency and organizational personnel who participate in, or provide support for, test operations at the Nevada Test Site (NTS). The Manager, NV, as the Site Manager, heads the NTSO (see Appendix "A").

0101-02 Organizational Concept and Policies

021 Nevada Test Site Organization (NTSO)

The Nevada Test Site Organization is a continuing task organization whose composition may be readily changed in response to the needs and technical objectives of the test program.

022 The NV staff, for the Manager, provides for the approval and coordination of program proposals, approvals for project support, funding and/or authority for financial agreement, legal counsel, contract authority and administration, engineering, accounting, classification and security policy and guidance, safety policy and guidance, environmental safety analyses, industrial relations, and public information policy to the NTSO.

023 Test execution shall conform to statutory, regulatory, and other responsibilities in accordance with delegations to the Manager, NV, by the General Manager of the Atomic Energy Commission.

024 Technical users are allowed maximum technical latitude in the conduct of their scientific programs and are responsible for their technical readiness.

- 025 User groups may be assigned areas in which to conduct their operations and exercise technical control subject to operational site coordination and control exercised by the Site Manager or, during a Test Execution Period, the Test Controller.
- 026 The Site Manager, NTS, has the authority to approve or disapprove the field execution of tests that have been approved by Headquarters AEC. During the Test Execution Period, authority to proceed with or postpone the field execution of approved activities or tests is delegated to the Test Controller in accordance with his Delegation of Authority from the Manager, NV.

0101-03 Responsibilities

- 031 The Site Manager is responsible for administering the NTS, for all preparations required for the safe execution of programs and projects at the NTS and for providing construction and logistic support services and facilities required to support the technical users.
- 032 The Test Controller is responsible to the Manager, NV, for the conduct of those experiments and test events in the testing program to which he is assigned by the Manager, NV.
- 033 The Deputy, Military Matters (Director, Test Directorate, FCDNA), serves as deputy for the Site Manager on operational, administrative and support matters pertaining to all DNA activities.
- 034 The Scientific Manager's Advisory Panel is chaired by a Scientific Advisor designated by the Manager, NV, as nominated by the technical user. Members of the panel provide advice on matters relative to on- and off-site safety.
- 035 The Test Group Directors (TGD) are assigned by the scientific sponsor to direct the fielding and technical aspects of experiments and tests. He reports to the Test Controller on operational matters relating to test execution.
- 036 The Director, Logistics Support, is responsible for the direction and control of construction and logistical support activities at the NTS and during Test Execution Periods, supports the Test Controller directly in the field execution of experiments and test events.
- 037 The Director, Operational Support, aided by the Operations Control Group and Special Staff assigned from NV as required, provides advice, assistance and serves as principal operations coordinator for the Site Manager and during the Test Execution Period, as Director of Operations for the Test Controller.
- 038 The Control Point Coordinator assures the availability in the OCC of facilities and equipment for the control and coordination of NTS operational activities.

- 039 The Test Operations Officer supervises the preparation of the Test Controller's operation and security plan and other required plans as directed. He coordinates preparations for the test execution and forward area support. During the Test Execution Period, he assists the Director of Operations in supervising and coordinating execution of the operations and security plan as directed by the Test Controller.
- 040 The Test Liaison Officer provides oral communication of test-related operational information from the operational control point (NTS) to NV and the Test Operations Center (TOC) AEC HQ during the Test Execution Period.
- 041 The FCDNA, Test Construction Division, is responsible for directing DOD furnished support.
- 042 The Technical Program Groups consist of organizational units and staff to satisfy the program objectives of their parent organizations.

DISTRIBUTION LIST

DNA-6325F

DEPARTMENT OF DEFENSE

ARMED FORCES STAFF COLLEGE
ATTN: LIBRARY

ASSISTANT SECRETARY OF DEFENSE
PUBLIC AFFAIRS
ATTN: PAO

ASSISTANT TO THE SECRETARY OF DEFENSE
ATTN: EXECUTIVE ASSISTANT

DEFENSE INTELLIGENCE AGENCY
ATTN: RTS-2B

DEFENSE NUCLEAR AGENCY
ATTN: GC
ATTN: PAO
5 CYS ATTN: RARP
25 CYS ATTN: TITL

DEFENSE NUCLEAR AGENCY
ATTN: TDTM-CF G CHAVEZ
ATTN: TDTT W SUMMA

DEFENSE TECHNICAL INFORMATION CENTER
2 CYS ATTN: DTIC/FDAB

FIELD COMMAND DEFENSE NUCLEAR AGENCY
4 CYS ATTN: FCLS
100CYS ATTN: FCLS MAJ J STINSON

NATIONAL DEFENSE UNIVERSITY
ATTN: ICAF-ICC

DEPARTMENT OF THE ARMY

PENTAGON LIBRARY
ATTN: ARMY STUDIES

U S ARMY CENTER OF MILITARY HISTORY
ATTN: DAMH-HSO

U S ARMY COMD & GENERAL STAFF COLLEGE
ATTN: LIBRARY

U S ARMY NUCLEAR & CHEMICAL AGENCY
ATTN: MONA-NU

U S ARMY WAR COLLEGE
ATTN: LIBRARY

DEPARTMENT OF THE NAVY

JAMES CARSON BRECKINRIDGE LIB
ATTN: LIBRARY DIV

MARINE CORPS BASE
ATTN: DOCUMENT CUSTODIAN

MARINE CORPS DEV & EDUCATION COMMAND
ATTN: J C BRECKINRIDGE LIB

MARINE CORPS HISTORY & MUSEUMS
ATTN: CODE HDH-2

MERCHANT MARINE ACADEMY
ATTN: DIRECTOR OF LIBRARIES

NAVAL AVIATION HISTORY
ATTN: LIBRARY

NAVAL MEDICAL COMMAND
ATTN: ASSISTANT FOR MEDICAL SURGERY

NAVAL OCEAN SYSTEMS CENTER
ATTN: LIBRARY

NAVAL OCEANOGRAPHIC OFFICE
ATTN: HISTORIAN

NAVAL POSTGRADUATE SCHOOL
ATTN: LIBRARY

NAVAL SCHOOL
ATTN: COMMANDING OFFICER

NAVAL SEA SYSTEMS COMMAND
ATTN: NUCLEAR TECHNOLOGY DIV
ATTN: TECH LIB

NAVAL SURFACE WARFARE CENTER
ATTN: LIBRARY

NAVAL WEAPONS CENTER
ATTN: CODE 233

NAVY DEPT LIBRARY
ATTN: LIBRN

OFC OF THE DEPUTY CHIEF OF NAVAL OPS
ATTN: NOP 0455

OFFICE OF THE JUDGE ADV GEN
ATTN: CODE 64.3

U S MERCHANT MARINE ACADEMY
2 CYS ATTN: LIBRN

US NAVAL AIR STATION LIB
ATTN: LIBRARY

DEPARTMENT OF THE AIR FORCE

AIR FORCE INSTITUTE OF TECHNOLOGY/EN
ATTN: C BRIDGMAN

AIR FORCE WEAPONS LABORATORY
ATTN: SUL

AIR UNIVERSITY LIBRARY
ATTN: AUL-LSE

MILITARY AIRLIFT COMMAND
ATTN: MACOS/XOND

DEPARTMENT OF ENERGY

DEPARTMENT OF ENERGY
ATTN: K MORRIS

DEPARTMENT OF ENERGY
ATTN: DOCUMENT CONTROL

DNA-6325F (DL CONTINUED)

DEPARTMENT OF ENERGY
ATTN: GRACE M PLUMMER

REYNOLDS ELECTRICAL AND ENGINEERING CO., INC.
2 CYS ATTN: B EUBANKS
2 CYS ATTN: E McDOWELL
2 CYS ATTN: W BRADY

LAWRENCE LIVERMORE NATIONAL LAB
ATTN: TECH INFO DIV

LOS ALAMOS NATIONAL LABORATORY
ATTN: M WALZ
2 CYS ATTN: REPORT LIBRARY

SANDIA NATIONAL LABORATORIES
ATTN: CENTRAL LIBRARY
5 CYS ATTN: G ZAMORA
ATTN: J METCALF
ATTN: ORG 400

OTHER GOVERNMENT

CENTRAL INTELLIGENCE AGENCY
ATTN: OFFICE OF MEDICAL SERVICES

DEPARTMENT OF HEALTH & HUMAN SVCS
ATTN: OFFICE OF GENERAL COUNSEL

EXEC OFC OF THE PRESIDENT
ATTN: LIBRN

LIBRARY OF CONGRESS
ATTN: LIBRARY SERVICE DIVISION
ATTN: SCIENCE & TECHNOLOGY DIV
ATTN: SERIAL & GOVT PUBLICATION

NATIONAL ATOMIC MUSEUM
ATTN: HISTORIAN

NATIONAL BUREAU OF STANDARDS
ATTN: LIBRN

OCCUPATIONAL SAFETY & HEALTH ADMIN
ATTN: LIBRARY

OFFICE OF WORKERS COMPENSATION PGRM
ATTN: R LARSON

U S HOUSE OF REPRESENTATIVES
2 CYS ATTN: COMMITTEE ON ARMED SERVICES
ATTN: COMMITTEE ON VETERANS AFFAIRS

U S HOUSE OF REPRESENTATIVES
ATTN: SUBCOMMITTEE ON HEALTH & ENVIR

U S SENATE
ATTN: COMMITTEE ON VETERANS AFFAIRS

U S SENATE
ATTN: COMMITTEE ON VETERANS AFFAIRS

VETERANS ADMINISTRATION-OFC CENTRAL
ATTN: DEPT VETERANS BENEFIT
ATTN: DIRECTOR BOARD OF VETERAN APPEAL

WHITE HOUSE (THE)
ATTN: DOMESTIC POLICY STAFF

DEPARTMENT OF DEFENSE CONTRACTORS

ADVANCED RESEARCH & APPLICATIONS CORP
ATTN: H LEE

JAYCOR
ATTN: A NELSON

KAMAN SCIENCES CORPORATION
ATTN: DASIAAC

KAMAN SCIENCES CORPORATION
ATTN: DASIAAC

NATIONAL ACADEMY OF SCIENCES
ATTN: C ROBINETTE

PACIFIC-SIERRA RESEARCH CORP
ATTN: H BRODE

TECH REPS, INC
ATTN: R HOLMES

DTRA/SCC-WMD Scientific & Technical Review Information

1. PA CONTROL NUMBER: <u>PA 13-385</u>	1a. SUSPENSE: _____
2. PM / PHONE / EMAIL: <u>Dr. Paul Blake,</u>	2a. DATE: <u>10 May 2013</u>
3. BRANCH CHIEF / PHONE /EMAIL: <u>N/A</u>	3a. DATE: <u>N/A</u>
4. DIVISION CHIEF / PHONE: <u>N/A</u>	4a. DATE: <u>N/A</u>
5. DEPARTMENTS / PHONE: <u>N/A</u>	5a. DATE: <u>N/A</u>
6. JDir / OFFICE / PHONE: <u>Byron L. Ristvet, DTRA Dep STI Mgr</u>	6a. DATE: <u>06 June 2013</u>
7. PUBLIC AFFAIRS: <u>Richard M. Ude</u>	7a. DATE: <u>10 Jun 2013</u>

8. TITLE: <u>DNA 6322F; DNA 6323F; DNA 6324F; DNA 6325F; DNA 6327F</u>	9. CONTRACT NUMBER: _____
10. ORIGINATOR: <u>DNA</u>	
11. TYPE OF MATERIAL: <input checked="" type="checkbox"/> PAPER <input type="checkbox"/> PRESENTATION <input type="checkbox"/> ABSTRACT <input type="checkbox"/> OTHER _____	

12. OVERALL CLASSIFICATION: CONTRACTOR PROJECT MANAGER UNCLASSIFIED

- A. Review authority for unclassified material is the responsibility of the PM. Your signature indicates the material has undergone technical and security review.
- B. Warning Notices/Caveats: RD FRD CNWDI NATO RELEASABLE
 SUBJECT TO EXPORT CONTROL LAWS

- C. Distribution Statement:
- A. Approved for public release; distribution is unlimited (unclassified papers only). Cleared for public release
- B. Distribution authorized to U.S. Government agencies only; (check the following):
- | | |
|--|--|
| <input type="checkbox"/> Contractor Performance Evaluation | <input type="checkbox"/> Proprietary Information |
| <input type="checkbox"/> Foreign Government Information | <input type="checkbox"/> Test and Evaluation |
| <input type="checkbox"/> Administrative or Operational Use | <input type="checkbox"/> Software Documentation |
| <input type="checkbox"/> Specific Authority | <input type="checkbox"/> Critical Technology |
| <input type="checkbox"/> Premature Dissemination | |
- JUN 19 2013
- C. Distribution authorized to U.S. Government agencies and their contractors: (check the following): Public Affairs
Defense Threat Reduction Agency
- | | |
|--|---|
| <input type="checkbox"/> Critical Technology | <input type="checkbox"/> Software Documentation |
| <input type="checkbox"/> Specific Authority | <input type="checkbox"/> Foreign Government Information |
| <input type="checkbox"/> Administrative or Operational Use | |
- D. Distribution authorized to the Department of Defense and U.S. DoD Contractors only; (check the following):
- | | |
|--|---|
| <input type="checkbox"/> Foreign Government Information | <input type="checkbox"/> Software Documentation |
| <input type="checkbox"/> Critical Technology | <input type="checkbox"/> Foreign Government Information |
| <input type="checkbox"/> Administrative or Operational Use | |
- E. Distribution authorized to DoD Components only; (check the following):
- | | |
|--|--|
| <input type="checkbox"/> Administrative or Operational Use | <input type="checkbox"/> Software Documentation |
| <input type="checkbox"/> Premature Dissemination | <input type="checkbox"/> Specific Authority |
| <input type="checkbox"/> Critical Technology | <input type="checkbox"/> Proprietary Information |
| <input type="checkbox"/> Foreign Government Information | <input type="checkbox"/> Test and Evaluation |
| <input type="checkbox"/> Direct Military Support | <input type="checkbox"/> Contractor Performance Evaluation |
- F. Further dissemination only as directed.
- X. Distribution authorized to U.S. Government agencies and private individuals or enterprises eligible to obtain export-controlled technical data in accordance with DoD Directive 5230.25 (unclassified papers only).

13. MATERIAL TO BE: Presented Published Date Required: _____

14. NAME OF CONFERENCE OR JOURNAL: _____

15. REMARKS: See Back of Form

OPSEC REVIEW/DATE

DTRA/SCC-WMD Scientific & Technical Review Information

REMARKS CONT:

The following DNA Reports have been carefully reviewed and are recommended for public release. These reports are a part of the DoD/ DTRA Nuclear Test Personnel Records program. In 1979, Admiral Robert Monroe, DNA Director directed that any DNA, DASA, or AFSWP reports supporting the NTPR program were to be reviewed, extracted, sanitized, etc., in order to provide them the public, such that appearance that the Agency was hiding relevant data could be adverted. The documents listed below are personnel-oriented histories of DoD participation in underground nuclear weapons testing during specific AEC, ERDA or DoE operations. Why these documents, which were originally assigned Distribution C, Critical Technology, but not included in that review direction is unknown. However, I, as UGT SME, and Herb Hoppe have reviewed and in our judgement see no reason for restricted distribution. We recommend their immediate public release. The five reports are:

DNA 6322F, Operations CROSSTIE and BOWLINE, 31 August 1967 - 20 November 1968.

DNA 6323F, Operations MANDREL and GROMMET, 12 September 1969 to 02 May 1972

DNA 6324F, Operations TOGGLE, ARBOR, and BEDROCK, 20 July 1972 - 05 April 1975

DNA 6325F, Operations ANVIL, CRESSET, TINDERBOX, and GUARDIAN, 24 October 1975 - 31 October 1980

DNA6227F, Operations PRAETROIAN, PHALANX, FUSILLEER, AND GRENADIER, 23 September 1982 - 06 April 1985

////////

If approved, please notify DTRIAC to change the Distribution Statement.

Byron L. Ristvet, Ph.D.

J9CXT

DTRA Dep STI Manger