

UNCLASSIFIED

AD NUMBER
ADB157113
NEW LIMITATION CHANGE
TO Approved for public release, distribution unlimited
FROM Distribution authorized to U.S. Gov't. agencies only; Proprietary Information; 29 JUN 1991. Other requests shall be referred to U.S. Army Medical Research and Development Command, Attn: SGRD-RMI-S, Fort Detrick, Frederick, MD 21702-5012.
AUTHORITY
Deputy Chief of Staff for Information Management, Ft Detrick/SGRD-RMI-S [70-1y], via memo dtd 7 Jun 1994

THIS PAGE IS UNCLASSIFIED

AD-B157 113



AD _____

L
D

CONTRACT NO: DAMD17-90-C-0052

TITLE: FLAVIVIRUS RNA REPLICATION: ESSENTIAL VIRAL FUNCTIONS
AS TARGETS FOR ANTIVIRAL THERAPEUTICS

PRINCIPAL INVESTIGATOR: Marc S. Collett
JoAnn A. Suzich

CONTRACTING ORGANIZATION: MedImmune, Inc.
19 Firstfield Road
Gaithersburg, MD 20878

REPORT DATE: April 30, 1991

TYPE OF REPORT: Annual Report

DTIC
SELECTE
AUG 6 1991
S B D

PREPARED FOR: U.S. ARMY MEDICAL RESEARCH AND DEVELOPMENT COMMAND
Fort Detrick, Frederick, Maryland 21702-5012

DISTRIBUTION STATEMENT: Distribution authorized to U.S.
Government agencies only, Proprietary Information, June 29, 1991.
Other requests for this document shall be referred to Commander,
U.S. Army Medical Research and Development Command, ATTN: SGRD-
RMI-S, Fort Detrick, Frederick, Maryland 21702-5012.

The findings in this report are not to be construed as an
official Department of the Army position unless so designated by
other authorized documents.

91 8 05 025

91-06849
UNCLASSIFIED

REPORT DOCUMENTATION PAGE

Form Approved
OMB No. 0704-0188

1a. REPORT SECURITY CLASSIFICATION Unclassified		1b. RESTRICTIVE MARKINGS	
2a. SECURITY CLASSIFICATION AUTHORITY		3. DISTRIBUTION / AVAILABILITY OF REPORT Distribution authorized to U.S. Government agencies only, Proprietary Information, June 29, 1991.	
4. DECLASSIFICATION / DOWNGRADING SCHEDULE		5. MONITORING ORGANIZATION REPORT NUMBER(S)	
6a. NAME OF PERFORMING ORGANIZATION Medimmune, Inc.		6b. OFFICE SYMBOL (if applicable)	7a. NAME OF MONITORING ORGANIZATION
6c. ADDRESS (City, State, and ZIP Code) 19 Firstfield Road Gaithersburg, MD 20878		7b. ADDRESS (City, State, and ZIP Code)	
8a. NAME OF FUNDING / SPONSORING ORGANIZATION U.S. Army Medical Research & Development Command		8b. OFFICE SYMBOL (if applicable) SGRD-RMI-S	9. PROCUREMENT INSTRUMENT IDENTIFICATION NUMBER Contract No. DAMD17-90-C-0052
9c. ADDRESS (City, State, and ZIP Code) Fort Detrick Frederick, Maryland 21702-5012		10. SOURCE OF FUNDING NUMBERS	
		PROGRAM ELEMENT NO 62787A	PROJECT NO 62787A271
		TASK NO AH	WORK UNIT ACCESSION NO WJDA346154
11. TITLE (Include Security Classification) Flavivirus RNA replication: Essential viral functions as targets for antiviral therapeutics			
12. PERSONAL AUTHOR(S) Marc S. Collett and JoAnn A. Suzich			
13a. TYPE OF REPORT Annual	13b. TIME COVERED FROM 90/3/30 TO 91/3/29	14. DATE OF REPORT (Year, Month, Day) 1991 April 30	15. PAGE COUNT 15
16. SUPPLEMENTARY NOTATION			
17. COSATI CODES		18. SUBJECT TERMS (Continue on reverse if necessary and identify by block number)	
FIELD	GROUP	Flavivirus; RNA replication; Enzymology; RNA-dependent RNA polymerase; peptide modeling; inhibitors; antivirals	
06	C2	RAI, BD	
19. ABSTRACT (Continue on reverse if necessary and identify by block number)			
<p>The objective of this contract research is to gain a detailed understanding of the molecular events involved in flavivirus RNA replication, with the ultimate aim being the identification of inhibitors of the process. We established yellow fever virus (YFV) as our study system. Necessary virologic, molecular biologic, and immunologic reagents have been obtained or were generated during this first year of work. Methodologies for detection, identification, and analysis of YFV polypeptides and RNA species are in place. Selected YFV protein coding regions were engineered into transcription expression plasmids and baculovirus transfer vectors. Evaluation of gene expression of the former constructs was performed in a mammalian cell transient transfection system. Several of the latter vectors were used to construct recombinant baculoviruses. Protein expression by two of them (bacNS3 and lacNS5) was established. The NS5 protein produced in bacNS5-infected Sf9 cells has been purified. A specific, reproducible, and quantifiable assay for RNA-dependent RNA polymerase (RDRP) activity involving a subcellular fraction derived from YFV-infected cells has been established. A number of peptide-based compounds were designed, synthesized, and tested for inhibition of the RDRP activity in this assay. Preliminary data suggested several were inhibitory. Molecular modeling applications are being investigated for their utility in assisting in next generation inhibitor design.</p>			
20. DISTRIBUTION / AVAILABILITY OF ABSTRACT <input type="checkbox"/> UNCLASSIFIED/UNLIMITED <input type="checkbox"/> SAME AS RPT <input type="checkbox"/> OTIC USERS		21. ABSTRACT SECURITY CLASSIFICATION Unclassified	
22a. NAME OF RESPONSIBLE INDIVIDUAL Mrs. Virginia M. Miller		22b. TELEPHONE (Include Area Code) 301-663-7325	22c. OFFICE SYMBOL SGRD-RMI-S

FOREWORD

Opinions, interpretations, conclusions and recommendations are those of the author and are not necessarily endorsed by the US Army.

Where copyrighted material is quoted, permission has been obtained to use such material.

Where material from documents designated for limited distribution is quoted, permission has been obtained to use the material.

X Citations of commercial organizations and trade names in this report do not constitute an official Department of Army endorsement or approval of the products or services of these organizations.

X In conducting research using animals, the investigator(s) adhered to the "Guide for the Care and Use of Laboratory Animals", prepared by the Committee on Care and Use of Laboratory Animals of the Institute of Laboratory Resources, National Research Council (NIH Publication No. 86-23, Revised 1985).

For the protection of human subjects, the investigator(s) adhered to policies of applicable Federal Law 45 CFR 46.

X In conducting research utilizing recombinant DNA technology, the investigator(s) adhered to current guidelines promulgated by the National Institutes of Health.

PI - *[Signature]*
Signature

DATE 4/1/71

PI - *[Signature]*
Signature

DATE 4/30/71

Accession For	
NTIS GRA&I	<input type="checkbox"/>
DTIC TAB	<input checked="" type="checkbox"/>
Unannounced	<input type="checkbox"/>
Justification	
By _____	
Distribution/	
Availability Codes	
Dist	Avail and/or
	Special
B-3	

TABLE OF CONTENTS

	Page
Front Cover	1
Report Documentation Page	2
Foreword	3
Introduction	5
Experimental System Set-up and Reagents	5
<i>Virologic reagents</i>	5
<i>Molecular biologic reagents</i>	5
<i>Immunologic reagents</i>	6
Engineered Gene Expression	7
RNA Replication Bioassay Development	7
<i>Infected cell-derived RDRP assay</i>	8
<i>Reconstituted component replication assays</i>	9
Inhibitor Design and Development	9
<i>Evaluation of candidate inhibitors</i>	10
<i>Molecular modeling analyses</i>	11
Summary and Conclusions	11
References	12
Figures	
Figure 1. Sequence-specific antiserum reagents to YFV proteins	13
Figure 2. YFV-T7 transcription plasmids	14
Figure 3. YFV-recombinant baculoviruses	15

Introduction

The general objective of this contract research is to obtain a detailed understanding of the molecular processes involved in flavivirus RNA replication. Toward this goal, studies involving the isolation and dissection of the replication apparatus found in virus-infected cells, and work dealing with the production and isolation of purified flaviviral proteins and their use in reconstructing component replication activities, are being pursued. Data from these *in vitro* approaches will not only significantly contribute to the elucidation of mechanisms involved in flavivirus RNA replication, but will also allow development of important *in vitro* assays for the component activities making up the viral replicase function. Provision of such assays, along with parallel protein structure-function studies, will then allow pursuit of our ultimate goal: identification and evaluation of compounds capable of interfering with these *in vitro* replication activities.

This report summarizes work performed during the first year of this contract. Much of our effort this past year involved the establishment of the experimental model system and the procurement and generation of necessary reagents. However, we have also made considerable headway in the two principle research areas of this project: RNA replication bioassay development and candidate inhibitor design and development.

Experimental System Set-up and Reagents

Virologic reagents.

We have obtained yellow fever virus (YFV) 17D from American Type Culture Collection (ATCC). We have also received, from C. Rice (Washington University), YFV 17D generated from the transfection of an infectious RNA copy of the molecularly cloned virus (YFiv 5.2; ref. 1). This latter virus has been propagated in SW-13 cells (obtained from ATCC). Conditions for virus plaquing have been established, and seed virus stocks and high titer working stocks have been prepared. Additional cell lines on hand include Vero, C6/36 cells (both obtained from USAMRIID), and BHK-21 cells (obtained from ATCC).

Molecular biologic reagents.

A series of plasmids possessing YFV 17D cDNA inserts which collectively encompass the entire virus genome have been graciously provided to us by C. Rice (clones p28III, pYFM 3.5, p34III, and pYF5'-3'ΔNP.9). Stocks of these plasmids have been prepared.

Immunologic reagents.

Mouse hyperimmune ascites fluid to YFV has been obtained from ATCC and from J. Dalrymple (USAMRIID). Small aliquots of a series of rabbit antisera specific to protein coding regions along the YFV genome (generated against *E. coli*-expressed YFV polypeptides) were provided by C. Rice. All of these reagents have been evaluated in radioimmunoprecipitation (RIP) analyses of YFV-infected BHK and SW-13 cell lysates. They have allowed the clear identification of YFV proteins prM, E, NS1, NS2B, NS3, NS4B, and NS5. Viral proteins not immunoprecipitated with these reagents from cell lysates were C, M, NS2A, and NS4A (which has not yet been identified in YFV-infected cells). Evaluation of 25 JEV monoclonal antibodies (provided by J. Dalrymple) by RIP assay of YFV-infected cell lysates identified two antibodies (11-H12-1 and 12-F9-3) cross-reactive with the YFV E protein.

We have invested considerable effort in generating our own sequence-specific antibody reagents to YFV proteins. Two types of immunogens have been prepared. First, a number of peptides (19 to 26mers) were synthesized representing sequences from the C, M, E, NS2A, NS2B, NS4A, NS4B, and NS5 protein coding regions (Fig. 1B). These synthetic peptides were chemically coupled (via MBS) to KLH, and the resulting conjugates were used to immunize rabbits. We have also produced sequence-specific immunogens by expressing select regions of the YFV open reading frame (ORF) in an *E. coli* expression system. Our system employs the tac promoter and results in production of a fusion protein in which the first 23 amino acids of the resultant protein represent the cro protein of bacteriophage λ (2). The regions of the ORF so engineered are schematically depicted in Figure 1C. With one exception, bacteria harboring these plasmid constructs each produced high levels (10-50 mg/l) of the expected polypeptide. The exception was croNS2A; while plasmid constructs could be verified correct, transformed *E. coli* failed to produce YFV-specific protein from this region. The successfully expressed bacterial YFV fusion polypeptides were partially purified and used to immunize rabbits as previously described (3,4).

Antisera were evaluated for their ability to immunoprecipitate radiolabeled antigens produced in YFV-infected SW-13 cells. Infected cells were labeled with ^{35}S -methionine (TRANS- ^{35}S -Label, ICN), and cleared cell lysates were prepared by either an SDS denaturation method (2) or by a RIPA buffer procedure (5). Following standard immunoprecipitation protocols (2,3), aliquots of the immunoprecipitates were analyzed by SDS polyacrylamide gel electrophoresis, and the radiolabeled antigens were detected by fluorography. Figure 1 summarizes the results of our evaluation of the various antibody reagents. Of nine synthetic peptide immunogens used, four elicited useful antisera reactive with specific YFV polypeptides (Fig. 1B). Each of the four *E. coli*-produced immunogens yielded positive antisera, although the anti-C protein antisera (croC-141) was of low titer (Fig. 1C).

Engineered gene expression

Important to understanding flavivirus RNA replication will be determining the functional roles of the individual components involved. Toward this end, we plan to exploit a number of gene expression systems for the production, and subsequent functional characterization, of individual YFV polypeptides. These expression systems include cell-free transcription-translation, mammalian cell transient expression, recombinant baculovirus-infected insect (Sf9) cells, and recombinant vaccinia virus-infected mammalian cells. The first two systems both involve bacteriophage T7 promoter-initiated transcription (either *in vitro* or *in vivo*). We have engineered a number of the YFV protein coding regions into T7 promoter-containing plasmids (Fig. 2). Each of these transcription constructs was evaluated for protein expression in a transfection assay in BHK cells infected with a vaccinia virus expressing the T7 RNA polymerase (6). Cells transfected with the M construct produced an 8 kDa protein, immunoprecipitable with our anti-M-211 serum, that comigrated with the M protein produced in YFV-infected cells. Cells transfected with the prM plasmid synthesized an M antiserum-reactive 20 kDa protein, consistent with the size expected for the unglycosylated prM protein. Since the construct lacks the prM signal sequence, glycosylation was not expected. Cells receiving the CprM plasmid produced a specific 37 kDa polypeptide, the size expected if no proteolytic processing of the fusion protein occurred. Only a small amount of mature prM protein was detected. The presence of C protein was not tested. Reasons for the inefficient processing in this transient system by cellular signalase are unclear. Cells transfected with the NS2B plasmid expressed the expected 15 kDa protein. Transient expression of the NS3 and NS5 constructs resulted in the ready identification of the expected 69 kDa and 98 kDa polypeptides, respectively. Finally, cells transfected with the NS3-5 plasmid produced a high molecular weight polyprotein immunoprecipitable with antiserum to both the NS3 protein and NS5.

A number of recombinant baculovirus transfer vectors possessing various YFV protein coding regions have been constructed (Fig. 3). To date, four of these vectors have been used to generate recombinant viruses. Of these, YFV protein expression in infected Sf9 cells has been evaluated for two of them. Both bacNS3 and bacNS5 produce the expected polypeptide, each co-migrating in an SDS polyacrylamide gel with their authentic YFV protein counterpart.

RNA Replication Bioassay Development

In order to investigate viral RNA synthesis, we needed to establish methods for extraction of intact YFV RNA from infected cells and for analysis of the various forms of viral RNA. These procedures are all in place at this time. Employing denaturing formaldehyde-agarose and high resolution urea-agarose gel electrophoresis, differential LiCl solubility, and RNase

sensitivity, we can readily resolve, distinguish, and identify viral genomic, replicative intermediate (RI), and replicative form (RF) RNAs.

Infected cell-derived RDRP assay.

During this first year, a major effort has been put into the development of a cell-free viral RNA transcription assay derived from YFV-infected cells. At year's end, we have at hand a specific, reproducible, and quantifiable assay involving a subcellular fraction possessing viral RNA-dependent RNA polymerase (RDRP) activity. Methods employed to generate this active fraction were partially modeled after approaches used by others in different viral systems (7-12). Preparation of this fraction involved the mechanical disruption of YFV-infected BHK cells in hypotonic buffer containing Triton X-100, followed by low speed centrifugation to remove large cell debris. From this initial supernatant fraction, a particulate fraction (P20) was isolated by centrifugation at 20,000 x g. The P20 fraction contained nearly all of the viral RDRP activity. This particulate material was then solubilized in deoxycholate (DOC) without loss of activity. Addition of glycerol to the DOC-solubilized P-20 fraction allowed storage of aliquoted material at -70° for several weeks with no apparent loss of RDRP activity.

Measurement of RDRP activity in this preparation involved standard reaction conditions including buffer, divalent cation, the four ribonucleoside triphosphates (NTPs), one of which is radiolabeled ($\alpha^{32}\text{P}$ -GTP), RNase inhibitor (RNasin), and actinomycin D. The RNA synthesizing activity of the P20 preparations was absolutely dependent on the addition of a divalent cation, with the optimal concentration of MgCl_2 being approximately 2.5 mM. Comparable activity was obtained at 0.5 mM MnCl_2 . However, it was rather insensitive to variations in the nature and concentration of salt in the reaction mixture. The RDRP activity was relatively constant over the range of 5 to 400 mM NaCl, 20 to 400 mM KCl, and 20 to 200 mM $(\text{NH}_4)\text{OAc}$.

Under standard reaction conditions in the presence of $\alpha^{32}\text{P}$ -GTP, the resultant radiolabeled product was analyzed by gel electrophoresis. Only viral RI and RF RNA species were found; no single strand genomic RNA was detected as a reaction product. However, in other work, we found that the P20 extract contains RNase activity as detected by the degradation of exogenously added RNA. Possibly, newly synthesized single strand RNA is degraded by this activity in this system. This is being investigated further.

Using material prepared as described above, we have obtained consistent and reproducible incorporation of radiolabel (^{32}P) into virus-specific RNA. The amount of radiolabel incorporated into the YFV 11 kb RNA species directly correlated with TCA precipitable counts from the reaction mixture. Furthermore, since the specific incorporation of ^{32}P is at least 10-fold over background counts, assessment of RDRP activity by simple TCA precipitation is possible. This allows for simple and accurate quantitation of activity by scintillation spectrometry.

The YFV-specific proteins and RNA present in the RDRP-active (P20) and inactive (P1 and S20) fractions were investigated. Viral proteins were identified by Western blot analysis. No significant difference in the distribution of viral proteins prM, E, NS1, NS2B, NS3, NS4B, and NS5 was observed among the three cell fractions. Mature M protein was detected only in the inactive P1 fraction. C protein was not identified in any of the fractions. Distribution of the NS2A and NS4A proteins was not determined. Viral RNA was analyzed in the subcellular fractions prepared from YFV-infected cells radiolabeled with ³H-uridine in the presence of actinomycin D. YFV-specific single strand genomic and double strand RF RNA were both equally distributed in all three fractions, while the majority of the RI RNA was found in the P1 fraction.

Reconstituted component replication assays.

The cell-derived RDRP activity described above will most certainly yield important data on YFV RNA replication as we continue our investigation, and further purification, of it. However, the preassembled nature of this replication complex will make it difficult to define and assess certain replication-associated interactions and component activities. Therefore, we proposed to purify relevant individual components for use in reconstituting various activities.

Efforts toward purification of the YFV proteins expressed in recombinant baculovirus bacNS3- and bacNS5-infected Sf9 cells have begun. Preliminary studies showed the bacNS3 protein to be present in the particulate fraction of hypotonically disrupted cells. Attempts to extract the bacNS3 protein with either Triton X-100 or high salt have been unsuccessful to date. The majority (but not all) of bacNS5 protein was also found in the particulate fraction of infected cells. However, this protein was readily extracted and solubilized with high salt. This salt extract was subjected to DEAE Sephacryl chromatography. BacNS5 protein was eluted with a linear salt gradient, and the bacNS5 protein-containing fractions were then applied to a poly(U)-Sepharose column. The bacNS5 protein eluted from this column was estimated to be >90% pure.

The purified bacNS5 protein was assayed for guanine methyltransferase activity. Using either GTP or GpppG as methyl acceptors, and ³H-S-adenosyl methionine as methyl donor, we were unable to detect activity in this preparation.

Inhibitor Design and Development

During this first year, our focus for consideration of RNA replication inhibitor candidates has been on oligopeptides. For this initial work, peptide sequences derived from two regions within the NS5 protein, the "SG" and "GDD" motifs, were selected for study due to their conserved nature among RNA replicases (13).

Evaluation of candidate inhibitors.

With the infected cell-derived soluble RDRP assay being established as reproducible and quantifiable, we have initiated efforts toward evaluation of the effects on this activity of the addition of several peptides to the reaction. A series of hexamers, based on conserved sequence motifs in the NS5 protein, have been designed, synthesized, and tested. Synthetic peptides representing these conserved sequences (mimetic peptides) were made, as were peptides predicted to be "complementary" to them. The basis for design of complementary peptides stems from the theory of hydrophobic anti-complementarity put forth by Blalock and Smith (14).

At final peptide concentrations in the reaction mixture of 50 and 250uM, none of the "GDD" mimetic peptides showed inhibitory activity. However, when tested at 1250uM, the GDD compound MedImmune (M) 96-10 exhibited significant inhibitory effect on RDRP activity (43% inhibition), while at this same concentration, GDD complementary hexamers M96-12, -13 and -14, and an unrelated hexamer (B3/2-7) had only minor effects on activity (0-15% inhibition). The "SG" hexamer M96-15 had only a slight inhibitory effect, even at 1250 uM. However, three SG complementary hexamers (M96-16, -17 and -18) all exhibited significant RDRP inhibition at the high peptide concentration; M96-16 and M96-17 being most potent (42% inhibition). Analysis of the reaction products synthesized in the absence or presence of 1250uM M96-10 or M96-17 on a denaturing formaldehyde-agarose gel revealed a clear decrease in the amount of radiolabeled YFV-specific 11 kb RNA made in the presence of each of these peptides.

We are cautious about interpretation of these results since significant inhibition of RDRP activity (40-45%) was observed only at very high peptide concentrations (mM). In attempts to determine the import of these observations, we have synthesized additional peptides and evaluated them in the cell-derived RDRP system. Two peptides representing the M96-17 sequence randomized (M96-21 and -22) exhibited no inhibitory activity. Evaluation of peptides in which single alanine substitutions were made for several of the residues in the M96-17 peptide (compounds M96-33 to M96-37), in every case resulted in loss of inhibitory activity. Of two randomized peptides of M96-10, one (M96-19) showed no inhibition, while the other (M96-20) inhibited the reaction to a similar extent as did M96-10. Deleting either terminal amino acid (M96-30 and -31), or both terminal amino acids (M96-23), in compound M96-10 abrogated inhibitory activity.

While these are intriguing results, considerable work lies ahead to validate specific inhibitory activities. Establishment of additional RDRP-related activity assays will be critical in this regard.

Molecular modeling analyses.

Computational analyses involving the application of dynamics and minimization techniques have been initiated to investigate the conformation of these peptides. We are employing the program "Discover" (Biosym Technologies) using Silicon Graphics (SGI) computers at USAMRIID in collaboration with Maj. Dallas Hack and the Cray X-MP computer at NCI-FCRF. An extensive dynamics, annealing, and minimization analysis of one cyclic hexamer (compound M96-11) revealed about 50,000 iterations of the process are required to largely cover all conformational space available to this peptide. This result indicates for this peptide, there is a limit to the unique conformational space it can occupy. Data generated by this procedure were analyzed by three distinct methods so as to classify each conformer into a conformational group or family. The first structural characterization method employed the program RMSfit (Biosym Technologies). RMSfit groups peptides having within 1 angstrom or less the same average root mean squared distance between all backbone atoms of the peptide. The second characterization method used a computer program called Conf (written by D.C. Feller and D.C. Hack). Conf assigns each residue of a peptide a conformational letter code according to the residue's phi and psi dihedral angles. Conformers having the same letter codes for all residues are grouped into a family. The third characterization method considers predicted secondary structure trends of each conformer (α -helix, β -sheet, β -turn).

Biosym Technologies has recently developed a conformational searching program that rapidly finds the global minimum (lowest energy conformation) of small peptides. We are in the process of testing this program to see if it can speed up the time of our analyses.

These computational analyses will form an initial conformational database for future inhibitor design. At this time, on its own, this database has little meaning. However, as we evaluate the bioactivity of peptides in the various replication assays under development, it will serve as a starting point for an iterative process attempting to correlate predicted peptide structural trends with peptide biological (inhibitory) activity.

Summary and Conclusions

We feel our first year has been a productive and fruitful one. We are largely on course with our originally proposed year 1 objectives. We have established our study system and have assembled many of the reagents necessary for future detailed studies of RNA replication. We believe immunologic reagents are critical tools for these upcoming investigations and have consequently invested considerable effort this first year in their generation. While many of these reagents are now at hand, more will be required. And so our efforts here will continue.

A number of YFV protein coding regions have been engineered into various of the surrogate expression systems. Our progress

here is beyond our original proposed first year objectives of cloning the NS3 and NS5 genes into transcription plasmids. While many constructs have been made (and more are to follow), their characterization and utilization was minimal. This next year, we will begin to exploit these reagents to uncover component activities associated with YFV RNA replication.

Development of an RDRP assay derived from virus-infected cells was a principal first year objective. Our progress in this area was considerable, as indicated in this report. An assay that is specific, reproducible, and readily quantifiable has been established. The availability of this assay allowed us to initiate studies we had not anticipated beginning until late in the second year of this program; that being the evaluation of compounds for RNA replication inhibitory activity. Our data suggest we have synthesized peptide compounds with some inhibitory activity. And while these results are potentially exciting, we are skeptical at this stage. Much of our near-term effort will be to validate or invalidate the specificity and selectivity of these lead compounds, and to investigate their possible mechanisms of action. In parallel with these biological investigations, we will intensify computational analyses of conformational trends among inhibitory compounds and their inactive analogs in a effort to identify useful parameters to guide future inhibitor design. We look forward to an exciting second year of investigations.

References

1. Rice, C et al. (1989) *New Biologist* 1,285-296.
2. Keegan, K and Collett, MS (1986) *J Virol* 58,263-270.
3. Collett, MS et al. (1988) *Virology* 165,200-208.
4. Kakach, LT et al. (1988) *J Virol* 62,826-833.
5. Brugge, JS and Erikson, RL (1977) *Nature* 269,346-347.
6. Fuerst, TR, et al. (1986) *PNAS* 83,8122-8126.
7. Chu, PWG and Westaway, EG (1985) *Virology* 140,68-79.
8. Chu, PWG and Westaway, EG (1987) *Virology* 157,330-337.
9. Grun, JB and Brinton, MA (1986) *J Virol* 60,1113-1124.
10. Grun, JB and Brinton, MA (1987) *J Virol* 61,3641-3644.
11. Grun, JB and Brinton, MA (1988) *J gen Virol* 69,3121-3127.
12. Hommel, GA and Schloemer, RH (1985) *Virus Res* 4,37-51.
13. Kamer, G and Arco, P (1984) *Nucleic Acids Res* 12,7269-7282.
14. Blalock, JE and Smith, EM (1984) *BBRC* 121,203-207.

Figure 1

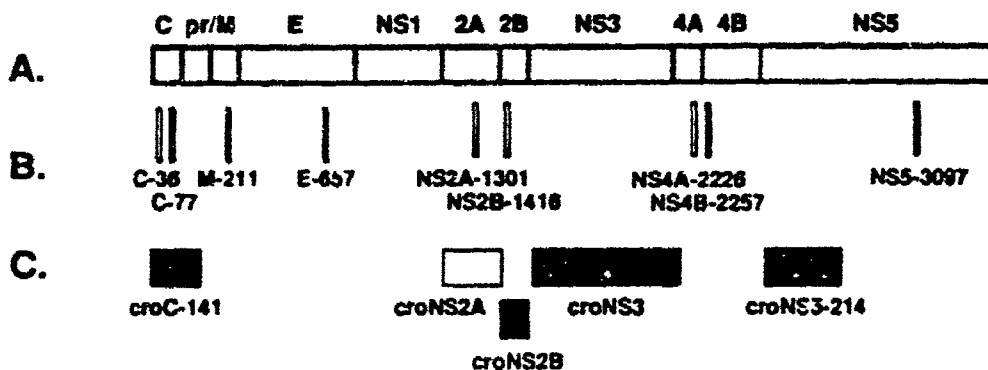

FIGURE 1. Sequence-specific antiserum reagents to YFV proteins. A. Schematic representation of the YFV ORF, indicating the coding boundaries for each of the viral proteins. B. Synthetic peptides prepared and used as immunogens. The number following the protein designation indicates the amino acid position within the ORF of the first residue of the respective peptide. The open bars indicate antisera elicited to the immunogen failed to recognize the respective YFV protein. Solid bars indicate useful antisera were generated. C. Regions of the YFV ORF engineered into *E. coli* expression vectors. In all but one case (croNS2A), fusion proteins were produced in bacteria harbouring these vectors. Immunization with these proteins resulted in the generation of useful antisera reactive with the authentic YFV proteins they each represented.

Figure 2

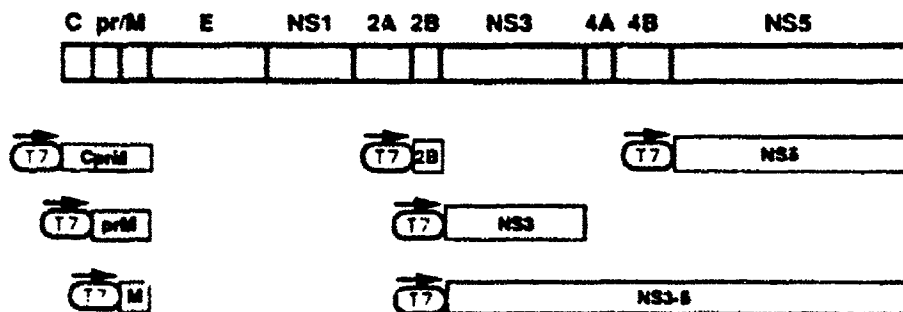

FIGURE 2. YFV-T7 transcription plasmids. The indicated protein coding regions of the YFV ORF were engineered into transcription plasmids downstream of the bacteriophage T7 promoter sequence.

Figure 3

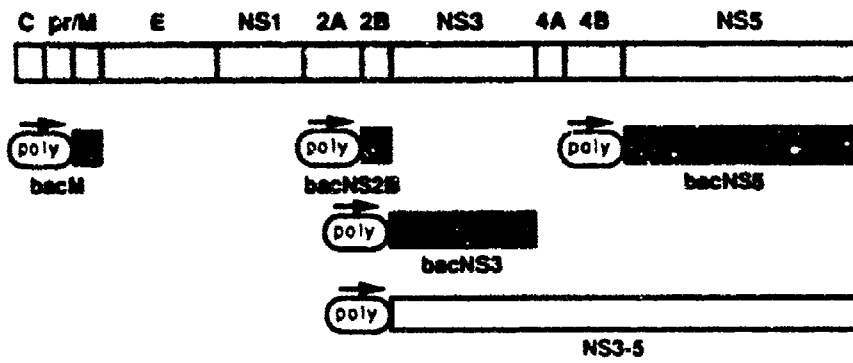

FIGURE 3. YFV-Recombinant baculoviruses. The indicated protein coding regions of the YFV ORF were engineered into baculovirus transfer vectors (pVL1392) downstream of the polyhedrin promoter sequence. The shaded constructs were then used to generate recombinant viruses.