

UNCLASSIFIED

AD NUMBER
ADB228823
NEW LIMITATION CHANGE
TO Approved for public release, distribution unlimited
FROM Distribution authorized to U.S. Gov't. agencies only; Proprietary Info.; 27 Jun 97. Other requests shall be referred to US Army Medical Rsch. and Materiel Comd., Fort Detrick, MD 21702-5012.
AUTHORITY
US Army Med Research and Mat Cmd, MCMR-RMI-S [70-1y], ltr 6 Jul 2000, Ft Detrick, MD

THIS PAGE IS UNCLASSIFIED

AD _____

GRANT NUMBER DAMD17-96-1-6016

TITLE: An Immunotherapeutic Approach to the Treatment and Prevention of Breast Cancer, Based on Epidermal Growth Factor Receptor Variant, Type III

PRINCIPAL INVESTIGATOR: Ms. Lisa K. Gilliam
Laura Hale, M.D., Ph.D.

CONTRACTING ORGANIZATION: Duke University Medical Center
Durham, NC 27710

REPORT DATE: July 1997

TYPE OF REPORT: Annual

PREPARED FOR: Commander
U.S. Army Medical Research and Materiel Command
Fort Detrick, Maryland 21702-5012

DISTRIBUTION STATEMENT: Distribution authorized to U.S. Government agencies only (proprietary information, 27 Jun 97). Other requests for this document shall be referred to Commander, U.S. Army Medical Research and Materiel Command, 504 Scott Street, Fort Detrick, Maryland 21702-5012.

The views, opinions and/or findings contained in this report are those of the author(s) and should not be construed as an official Department of the Army position, policy or decision unless so designated by other documentation.

19970910 064

REPORT DOCUMENTATION PAGE

Form Approved
OMB No. 0704-0188

Public reporting burden for this collection of information is estimated to average 1 hour per response, including the time for reviewing instructions, searching existing data sources, gathering and maintaining the data needed, and completing and reviewing the collection of information. Send comments regarding this burden estimate or any other aspect of this collection of information, including suggestions for reducing this burden, to Washington Headquarters Services, Directorate for Information Operations and Reports, 1215 Jefferson Davis Highway, Suite 1204, Arlington, VA 22202-4302, and to the Office of Management and Budget, Paperwork Reduction Project (0704-0188), Washington, DC 20503.

1. AGENCY USE ONLY (Leave blank)	2. REPORT DATE July 1997	3. REPORT TYPE AND DATES COVERED Annual (1 Jun 96 - 31 May 97)	
4. TITLE AND SUBTITLE An Immunotherapeutic Approach to the Treatment and Prevention of Breast Cancer, Based on Epidermal Growth Factor Receptor Variant, Type III		5. FUNDING NUMBERS DAMD17-96-1-6016	
6. AUTHOR(S) Ms. Lisa K. Gilliam Laura Hale, M.D., Ph.D.		8. PERFORMING ORGANIZATION REPORT NUMBER	
7. PERFORMING ORGANIZATION NAME(S) AND ADDRESS(ES) Duke University Medical Center Durham, North Carolina 27710		10. SPONSORING / MONITORING AGENCY REPORT NUMBER	
9. SPONSORING / MONITORING AGENCY NAME(S) AND ADDRESS(ES) U.S. Army Medical Research and Materiel Command Fort Detrick, Maryland 21702-5012		11. SUPPLEMENTARY NOTES	
12a. DISTRIBUTION / AVAILABILITY STATEMENT Distribution authorized to U.S. Government agencies only (proprietary information, 27 Jun 97). Other requests for this document shall be referred to Commander, U.S. Army Medical Research and Materiel Command, 504 Scott Street, Fort Detrick, Maryland 21702-5012.		12b. DISTRIBUTION CODE	
13. ABSTRACT (Maximum 200 words) <p>Prevention of metastatic breast cancer is limited to early detection and surgical resection of a localized tumor. Treatment for advanced breast cancer is often unsuccessful due to micrometastasis of the tumor prior to therapy. Thus, new methods to treat and prevent metastatic breast cancer are sorely needed.</p> <p>EGFRvIII, a variant of the epidermal growth factor receptor, is found in a large percentage of breast cancers but not in normal adult tissues and is thus a viable target for immunotherapy. We are studying two approaches to induce a cytotoxic response against EGFRvIII-bearing tumors. The first approach increases the sensitization of cytotoxic T-cells by enhancing loading of antigen onto host antigen presenting cells, making these cells <i>extremely</i> effective at presenting antigen to the immune system. The second approach utilizes a bispecific antibody against both EGFRvIII and a T-cell activation antigen redirecting the cytotoxic response of T-cells with a broad range of specificities against breast cancer cells that express EGFRvIII.</p> <p>These studies will result in an increased understanding of the role of EGFRvIII in breast cancer biology. Additional benefits include the development of specific, non-toxic, and effective immunotherapies for treatment and prevention of breast cancer and other tumor types.</p>			
14. SUBJECT TERMS Breast Cancer Epidermal Growth Factor Receptor Immunotherapy		15. NUMBER OF PAGES 16	
17. SECURITY CLASSIFICATION OF REPORT Unclassified		16. PRICE CODE	
18. SECURITY CLASSIFICATION OF THIS PAGE Unclassified		20. LIMITATION OF ABSTRACT Limited	
19. SECURITY CLASSIFICATION OF ABSTRACT Unclassified		14. SUBJECT TERMS Bispecific Antibody Cytotoxicity Antigen Presentation	

DTIC QUALITY INSPECTED 4

FOREWORD

Opinions, interpretations, conclusions and recommendations are those of the author and are not necessarily endorsed by the U.S. Army.

_____ Where copyrighted material is quoted, permission has been obtained to use such material.

_____ Where material from documents designated for limited distribution is quoted, permission has been obtained to use the material.

_____ Citations of commercial organizations and trade names in this report do not constitute an official Department of Army endorsement or approval of the products or services of these organizations.

_____ In conducting research using animals, the investigator(s) adhered to the "Guide for the Care and Use of Laboratory Animals," prepared by the Committee on Care and Use of Laboratory Animals of the Institute of Laboratory Resources, National Research Council (NIH Publication No. 86-23, Revised 1985).

For the protection of human subjects, the investigator(s) adhered to policies of applicable Federal Law 45 CFR 46.

_____ In conducting research utilizing recombinant DNA technology, the investigator(s) adhered to current guidelines promulgated by the National Institutes of Health.

_____ In the conduct of research utilizing recombinant DNA, the investigator(s) adhered to the NIH Guidelines for Research Involving Recombinant DNA Molecules.

_____ In the conduct of research involving hazardous organisms, the investigator(s) adhered to the CDC-NIH Guide for Biosafety in Microbiological and Biomedical Laboratories.

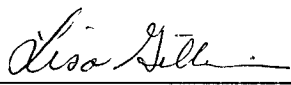

PI - Signature

6/27/97

Date

Table of Contents

1.	Front Cover	page 1
2.	SF298, Report Documentation Page	2
3.	Foreword	3
4.	Table of Contents	4
5.	Introduction	5-8
6.	Body	9-15
7.	Conclusions	15
8.	References	16

Introduction

Breast Cancer

Breast cancer, the most prevalent cancer in women, affects one out of eight American women accounting for 32% of new cancer cases and 18% of deaths due to cancer (Parker, Tong et al. 1996). Technological advances, such as the mammogram, and increased awareness among the population have played a significant role in the early detection of breast tumors and consequent cure by surgical resection of those patients who are treated early in their disease. However, breast cancer remains a devastating and usually incurable disease for women in whom metastasis or micro-metastasis has already occurred before therapy is instituted. High dose chemotherapy and bone marrow transplantation is currently the only potentially curative treatment for such women. Chemotherapy is toxic for dividing cells in the body; hence, its relative specificity for tumor cells lies in the fact that these cells are rapidly proliferating. However, this therapy is also toxic to normal dividing cells, which accounts for many of its serious and potentially life-threatening side effects, such as bone marrow suppression and gastrointestinal mucositis. Furthermore, although chemotherapy has a very high cure rate for some types of cancers including acute lymphoblastic leukemia, gestational trophoblastic disease, and testicular cancer, its usefulness has been limited in treating breast cancer. Therefore, new types of therapy to prevent or cure metastatic disease are sorely needed.

Immunotherapy

In 1970, Macfarlane Burnet coined the term "immunosurveillance" to describe the hypothesis that "an important and possibly primary function of immunological mechanisms is to eliminate cells which as a result of somatic mutation or some other inheritable change represent potential dangers to life." (Burnet 1970) Proponents of the concept of immunosurveillance believe that this "policing" activity of the immune system plays a very important role in the day-to-day prevention of the development of cancer in an individual. It is clear that there is an interaction between tumors and the immune system, but the importance of this interaction in natural *in vivo* defense against cancer remains controversial. Regardless of whether the immune system *naturally* plays an important role in defense against tumor development, countless animal studies and preliminary clinical studies have suggested that manipulation of an individual's immune system may provide a specific, effective, and relatively non-toxic therapeutic modality for tumors (termed

immunotherapy). Several different immunotherapeutic approaches to treating tumors are undergoing clinical trials, including the administration of a patient's own lymphocytes which have been activated *in vitro* (lymphokine activated killer cells, or LAK cells) as adjuvant therapy for metastatic or micrometastatic disease (reviewed in Sussman, Shu et al. 1994), the transfection of cytokines into the tumor cells themselves to form an autologous tumor vaccine (Gilboa, Lyerly et al. 1994), and the administration of tumor-specific antibodies conjugated to a toxin or radionuclide to enhance the specificity of an otherwise non-specific chemotherapeutic agent or radiation therapy (reviewed in Pai and Pastan 1994). Each of these modes of therapy requires that the immune system be able to differentiate between tumor cells and normal cells, via antigens expressed solely or predominantly by the tumor cells (tumor specific or associated antigens).

EGFRvIII

The wild-type epidermal growth factor receptor (EGFR) is a 170 kDa transmembrane protein which serves to transmit growth stimulatory signals from the surface of the cell to the cell's interior. Because of EGFR's role in the proliferative signaling pathway, it is capable of cellular transformation via two mechanisms: overexpression of the structurally normal protein, or activation of the molecule via a molecular event. Dr. Darell Bigner at Duke as well as others have demonstrated that rearranged variants of the EGFR are expressed in a variety of malignancies, including breast carcinomas (Wikstrand, Hale et al. 1995). The most frequently detected variant, type III (denoted EGFRvIII), is characterized by an 801 base pair deletion resulting in the loss of 267 amino acids spanning the first and second extracellular domains of the receptor, with generation of a glycine residue at the novel splice site. EGFRvIII binds EGF, but with markedly decreased affinity relative to structurally normal EGFR. Furthermore, the transforming potential of EGFRvIII is ligand-independent and unregulated *in vivo* and *in vitro* (Batra, Castelinoprabhu et al. 1995). Both of these observations suggest that naturally occurring EGFRvIII may play an oncogenic role in the tumor cells in which it is expressed, since these abnormal proteins may be capable of functioning in the absence of EGF. Consequently, cells expressing EGFRvIII would have a growth advantage over cells expressing the structurally normal EGFR in the presence of low levels of EGF (Bigner, Humphrey et al. 1990).

The most significant finding with respect to EGFRvIII, however, is that this protein appears to be both commonly and exclusively found in particular types of malignancies in adult tissues. We have demonstrated the presence of EGFRvIII protein by immunohistochemistry in 3/11 breast

carcinomas tested, with mRNA corresponding to EGFRvIII detectable in these 3 plus an additional 5 (total 8/11) by RT-PCR followed by ethidium bromide staining (Wikstrand, Hale et al. 1995). Furthermore, flow cytometric analysis demonstrated cell-surface reactivity of tumor cells with anti-EGFRvIII mAbs in 5 of 5 mechanically-dissociated primary breast carcinomas. No normal adult tissues tested, including those from the peripheral and central nervous system, the lymphoid system, skin, breast, liver, lung, ovary, testes, kidney, and colon have been found to express EGFRvIII by immunohistochemical and/or genetic analysis (Wikstrand, Hale et al. 1995). **Thus, EGFRvIII may be a tumor-specific antigen and a useful target for specific therapies including immunotherapy.**

Hypothesis and Technical Objectives: The goal of this project is to evaluate the feasibility of and develop new strategies for immune-based therapy for breast cancer, based on expression of the tumor-associated antigen EGFRvIII. My proposal includes the following technical objectives:

- 1) *The expression pattern of the epidermal growth factor receptor variant III (EGFRvIII) tumor antigen, including tumor specificity and prevalence, will be determined for a large panel of specimens from breast cancer patients, for established breast cancer cell lines, and for a broad spectrum of normal adult and fetal tissues, using RT-PCR, flow cytometry, immunohistochemistry, and Western blot assays.*
- 2) *The existence of a naturally occurring anti-EGFRvIII immune response in breast cancer patients as well as the ability to generate a humoral or cellular immune response against EGFRvIII in these patients will be tested in vitro, using enzyme immunoassays of patients' serum and cytotoxicity assays of patient TILs and PBLs against antigen presenting cells loaded with EGFRvIII-specific peptides.*
- 3) *An antibody specific for both EGFRvIII and CD3 ϵ will be constructed to investigate this bispecific construct as a means to bypass requirements for specific T-cell receptor/peptide-MHC matching and to redirect CTLs to kill tumor cells regardless of their natural specificity.*

During the past year, I have focused on Technical Objective #3, completing the work outlined in the Statement of Work for year 1 and making significant progress on the work proposed for year 2. I expect that the construction of the bispecific antibody will be completed ahead of schedule. Work on Technical Objective #1 has focused on identifying and

collecting appropriate tissues, since the studies are more efficient and accurate if performed in larger volumes. During year 1, we have significantly increased the number of tissues in our tissue bank. We now have more than 375 tissues in our bank, including 36 breast carcinomas as well as other tumor and normal tissues, which will enable the evaluation of EGFRvIII expression in tissue specimens to be complete and rapid.

Preliminary data obtained in studies outlined in Technical Objective #2 suggest that breast cancer patients may potentially be able to generate an immune response to EGFRvIII, a concept confirmed by similar studies done using murine EGFRvIII in mice in other projects in Dr. Hale's laboratory.

Thus, over year 1 of this project, I have made considerable progress toward a multifaceted approach to immune-based prevention and/or treatment of breast cancer based on the widespread and tumor-specific expression of EGFRvIII.

Furthermore, I am on schedule to complete the work proposed in Technical Objectives #1-3 within the allotted time.

Body

Thymic Expression of EGFRvIII

The thymus is the site of negative selection of T-cells, the cells required for the generation of both humoral and cytotoxic immune responses. Expression of cellular proteins by cells within the thymus during thymic development usually results in anergy of the developing T-cells for that particular protein. Thus, one important question addressing the feasibility of generating an immune response against EGFRvIII in breast cancer patients is whether or not EGFRvIII is expressed in the thymus. To rule out the possibility that the T-cells of breast cancer patients might be anergized to EGFRvIII by negative selection in the thymus, I performed RT-PCR on 10 post-natal thymus tissues, using primers that amplify a product of 1037 bp if wild-type EGFR message is present and 236 bp if EGFRvIII message is present. None of the 10 thymuses tested expressed message for the EGFRvIII protein (Figure 1a). These results were confirmed by Southern Blot analysis for 5 of the 10 thymus tissues tested (Figure 1b). These data suggest that T-cells undergoing post-natal selection are not likely to be anergized to EGFRvIII in the thymus, and thus EGFRvIII may be a viable target antigen for immunotherapy.

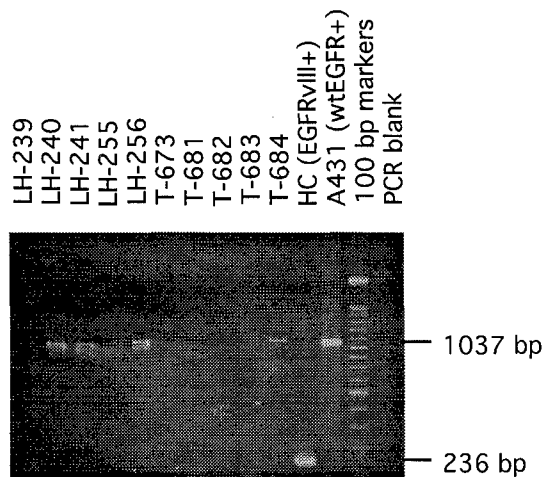

Figure 1a

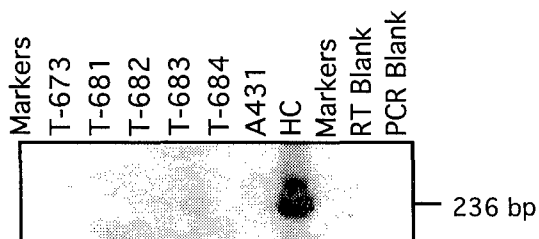

Figure 1b

Figure 1a: Determining the expression of WT EGFR and EGFRvIII in post-natal thymus by RT-PCR. mRNA was extracted from ten thymus tissues (lanes 1-10) and analyzed by RT-PCR. Although many of the thymus tissues contain wild type EGFR (PCR product of 1037 bp), none show a product consistent with EGFRvIII (236 bp). Positive controls include HC cells, expressing EGFRvIII (lane 11), and A431 cells, expressing WT-EGFR (lane 12). 100 base pair markers are shown in lane 13, and negative control lacking template is shown in lane 14.

Figure 1b: Determining the expression of WT EGFR and EGFRvIII in post-natal thymus by Southern Blot. PCR products from five thymus tissues were analyzed by Southern Blot. Lanes were loaded as labelled, and controls used were identical to those described in the legend for figure 1a. In addition, a negative control lacking reverse transcription was included (RT Blank). Reactivity with the EGFRvIII probe was limited to the HC positive control cell line (transfected with EGFRvIII).

Bispecific Antibody Construction

A large portion of the work for this part of the project (Technical Objective #3) has already been accomplished. In brief, I have proposed to generate a bispecific antibody (bsAb) in which a bispecific F(ab')₂ heterodimer against both EGFRvIII and CD3_ε is genetically engineered using leucine zippers, according to the method of Kostelny, Cole et al. 1992. The strategy I have used links leucine zipper peptides derived from the Fos and Jun proteins to the Fab' portions of EGFRvIII and CD3_ε mAbs by gene fusion using PCR. The result is well-defined, homogeneous, heterodimeric proteins that are unable to crosslink T-cell receptors in the absence of EGFRvIII-bearing tumor cells, thus avoiding complex purification and chemical processes and resulting in decreased potential for toxicity. The expression vector I originally planned to use (pSV2ΔHgpt-HuG1), constructed in Sherie Morrison's lab at UCLA, contains the entire human IgG1 sequence, CMV promoter, selectable marker, and a restriction enzyme site designed for insertion of an immunoglobulin variable region. This vector has been used to generate several constructs in Darrell Bigner's laboratory and has been shown to express Ig at high levels when co-transfected with the light chain vector (pSV184ΔHneo-HuK) into myeloma cells.

First, I cloned the heavy and light chain variable regions from the anti-CD3_ε hybridoma cell line, OKT3 and from the anti-EGFRvIII hybridoma cell line, L8A4 by RT-PCR (Figures 2a and 2b).

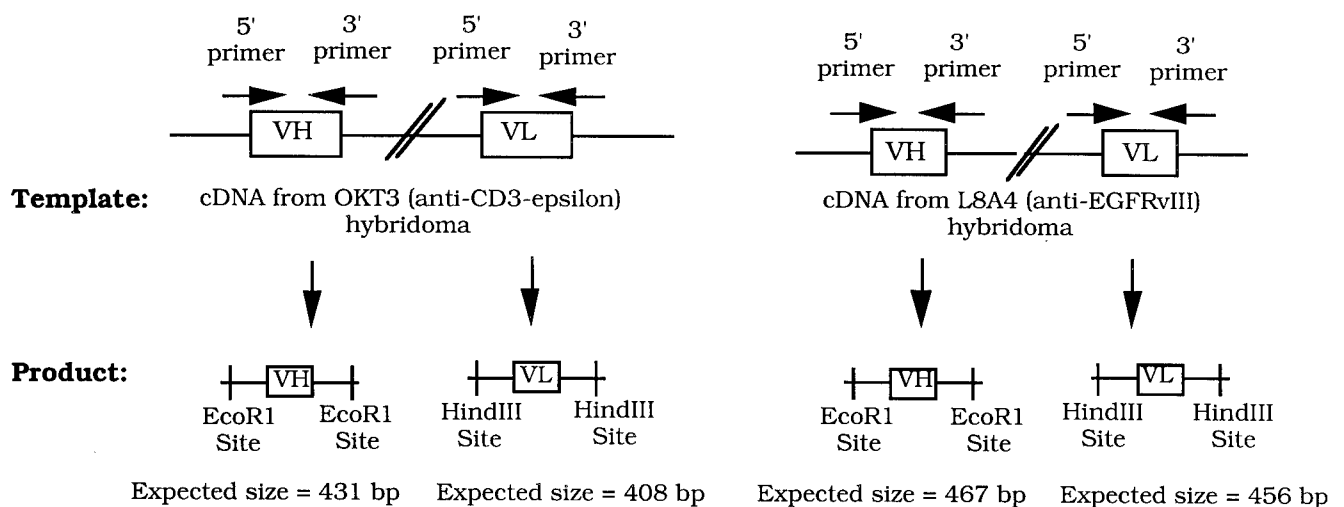
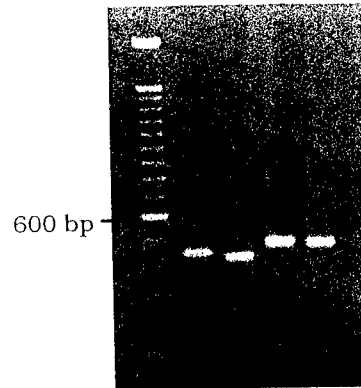

Figure 2a: Strategy for PCR amplification and cloning of anti-EGFRvIII and anti-CD3_ε variable regions

Figure 2b: PCR products were analyzed on a 1.5% agarose gel and detected by ethidium bromide staining. The gel was loaded as follows: 100 bp markers (lane 1), OKT3 variable region heavy chain (lane 2), OKT3 variable region light chain (lane 3), L8A4 variable region heavy chain (lane 4), L8A4 variable region light chain (lane 5)



For construction of the IgG-leucine zipper fusion gene, I initially planned to use a BstX1 site, unique in the CH1 region of the human IgG1 sequence, as a means of removing the unnecessary portions of the IgG1 constant region from the intended expression vector and replacing them with the PCR-generated IgG1-leucine zipper fusion gene. Then, I planned to insert the specific cloned variable region (OKT3 or L8A4) into the variable region cloning site to complete the construct. I successfully joined the fos or jun leucine zipper sequences to the first codon of the C_H2 exon of the human IgG1 gene, using the overlapping PCR method described by Yon and Fried (Yon and Fried 1989). These IgG1/Fos and IgG1/Jun constructs were then inserted into the PCRII cloning vector, and a PCR-generated poly-A tail was ligated into the vector immediately following the fusion gene sequences (Figures 3a and 3b). Unfortunately, when I tried to insert the completed construct into the expression vector, I found that the vector had several previously unidentified BstX1 sites which cleaved preferentially with respect to the desired BstX1 cleavage and thus precluded specific insertion of the construct.

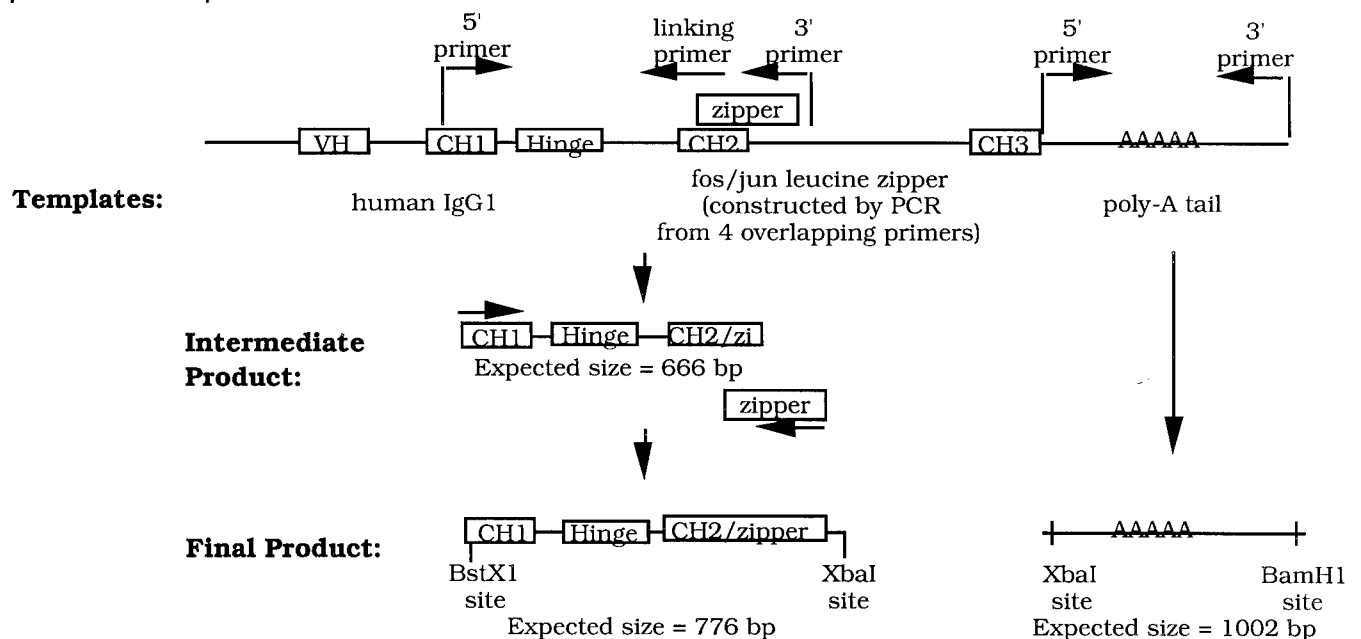
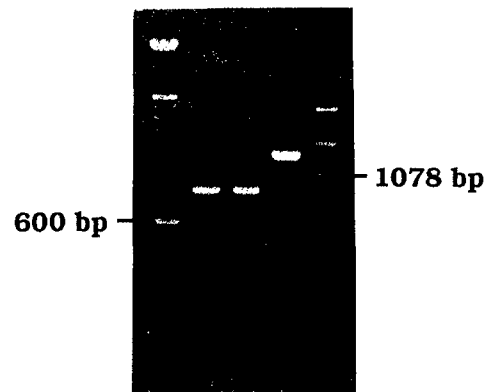
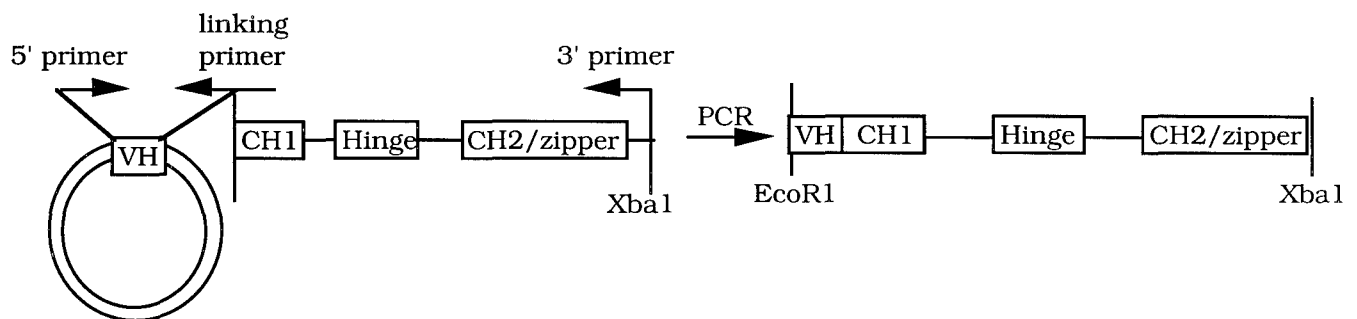

Figure 3a: Strategy for construction of a fusion gene (antibody constant region + leucine zipper) by overlapping PCR

Figure 3b: PCR Products were analyzed on a 1.5% agarose gel and detected by ethidium bromide staining. The gel was loaded as follows: 100 bp markers (lane 1), IgG1-Fos fusion (lane 2), IgG1-Jun fusion (lane 3), Poly-A tail (lane 4), ϕ X174/HaeIII markers (lane 5)



Thus, I devised another strategy for construction of the bsAbs. Again, I used the overlapping PCR method to join the jun or fos leucine zipper sequence to the first codon of the C_H2 exon of the human IgG1 gene, this time including the *entire* coding sequence of the C_H1 and hinge regions and the first codon of the C_H2 exon. The cloned OKT3 sequence was then directly joined (in a second fusion PCR step) to the beginning of the IgG1-fos fusion gene, with the L8A4 sequence joined to the IgG1-jun fusion gene in an analogous fashion (Figure 4).



PCR Templates: Product from fusion PCR#1 and cloned variable regions from OKT3 and L8A4

Figure 4: Strategy for joining the appropriate heavy chain variable region to the IgG1/Fos or IgG1/Jun fusion gene by overlapping PCR

These gene fusions were sequenced to rule out PCR-generated mistakes. One clone with the correct sequence (OKT3/IgG1-Fos #7) has been identified, and I am in the process of sequencing the L8A4/IgG1-Jun clones as well as the cloned vectors containing the OKT3 and L8A4 light chain variable regions.

Once constructs with the correct sequences have been identified, the heavy chain fusion genes will be inserted with the poly-A tail into the pSV2ΔHgpt-HuG1 vector utilizing its EcoR1 and BamH1 sites. This method utilizes unique restriction sites in the expression vectors for insertion of the constructs and eliminates the requirement for identification of a unique restriction site in the beginning of the IgG1 sequence (Figure 5a).

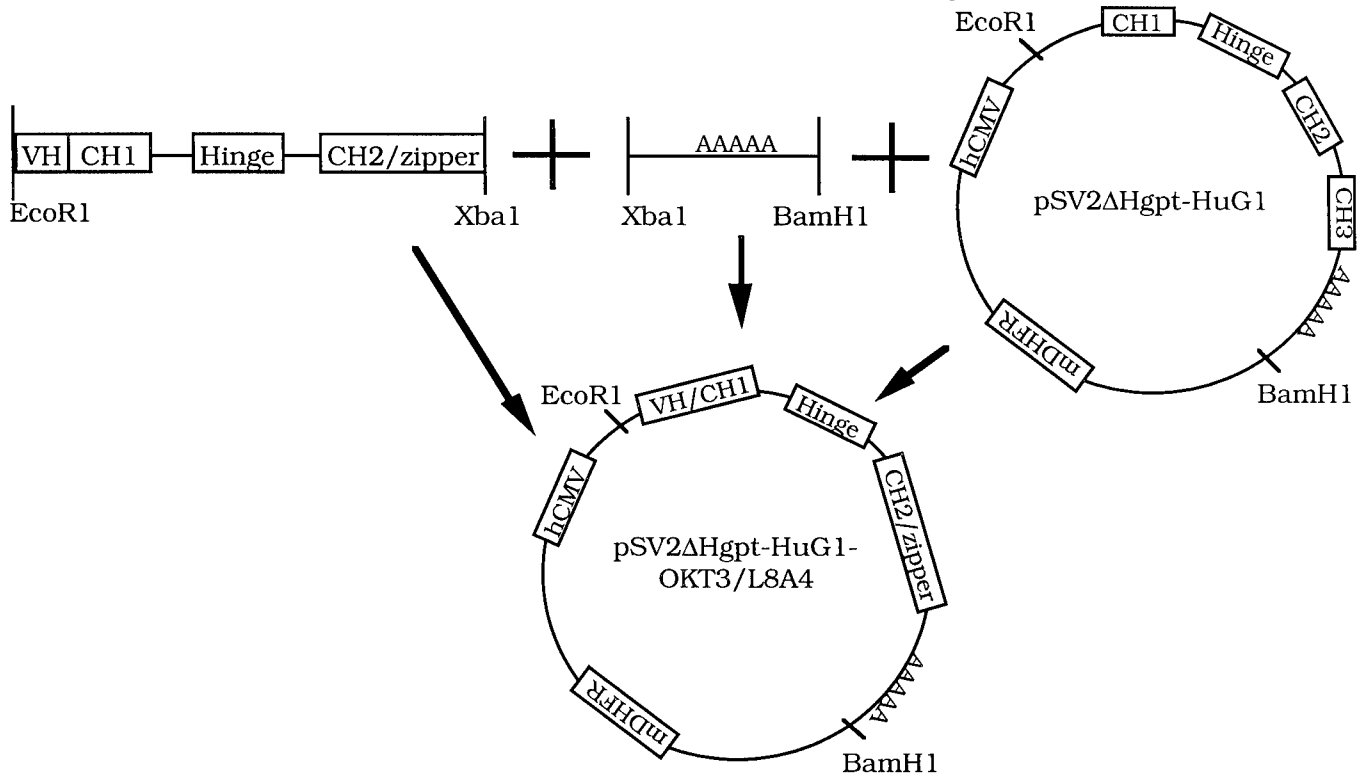

Figure 5a: Construction of heavy chain expression vectors

For light chain expression, analogous plasmids will be prepared that respectively contain the V_L genes of L8A4 and OKT3 together with the human C_K gene (Figure 5b).

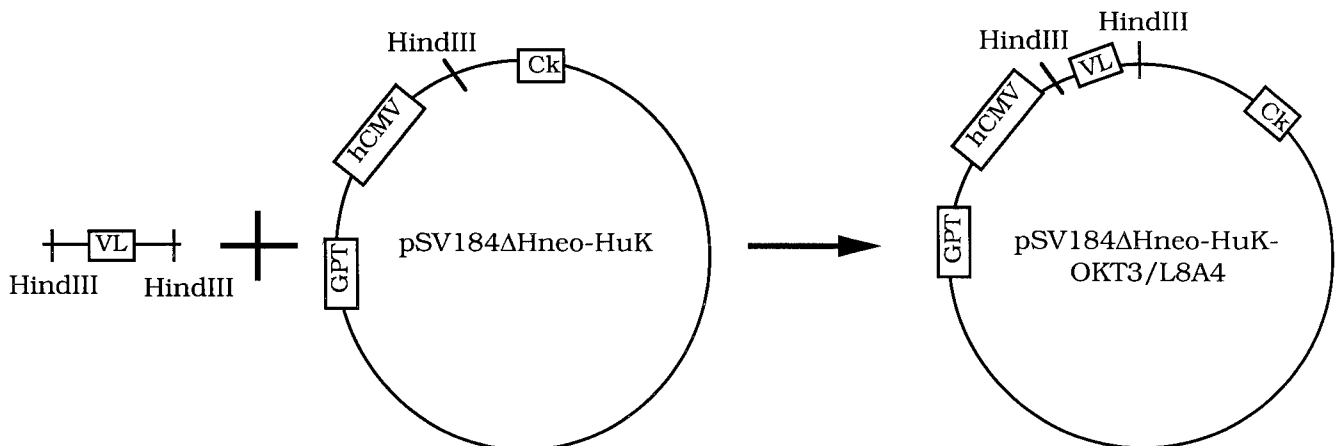

Figure 5b: Construction of light chain expression vectors

After these constructs have been produced and transfected into myeloma cells, culture supernatant will be screened for anti-EGFRvIII or anti-CD3 ϵ activity followed by purification, heterodimerization, and characterization of the bsAb products (Figure 6). Thus, despite the unanticipated difficulties which arose in preparation of these bsAb molecular constructs, we are ahead of the schedule anticipated in our statement of work.

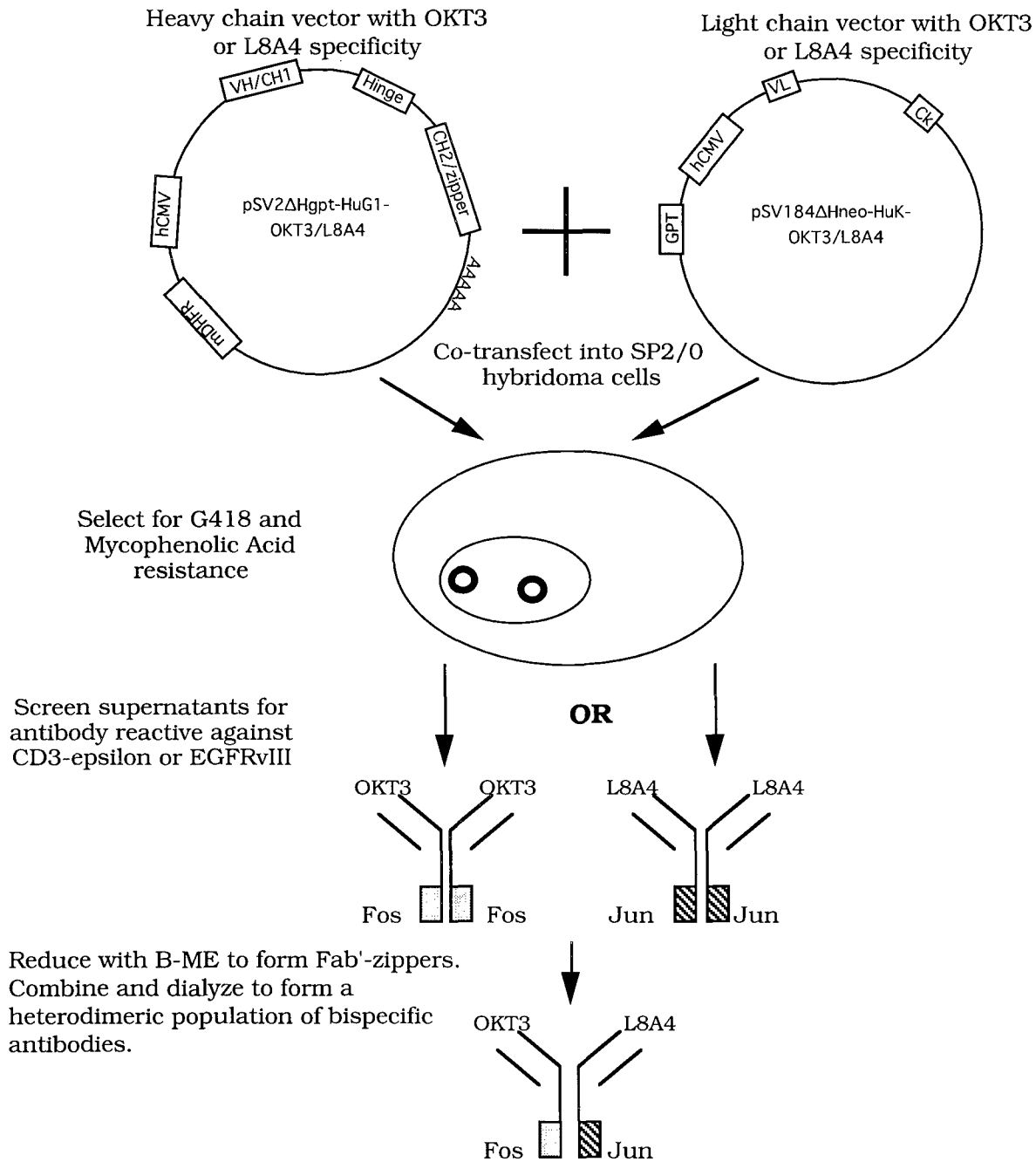

Figure 6: Transfection of immunoglobulin expression vectors into SP2/0 hybridoma cells and production of an antibody bispecific for EGFRvIII and CD3 ϵ

EGFRvIII Transfected Breast Cancer Cell Lines

Characterization of the antibodies bispecific for EGFRvIII and CD3 ϵ will involve functional testing using CTL assays in which naive effector cells are incubated with non-MHC matched EGFRvIII-expressing target cells. Lysis of the target cells will suggest that we have, in fact, bypassed the specificity of the T-cells in generating this cytotoxic response. We have analyzed 4 human breast cancer permanent cell lines (MCF-7, MDA-MA-231, SKBR3, and ZR75-1) for the presence of EGFRvIII by RT-PCR analysis and found that none express this EGFR variant. Therefore, it will be necessary to construct EGFRvIII expressing breast cancer targets by transfection of EGFRvIII cDNAs, a process we have successfully accomplished in murine cell lines. Attempts to transfect EGFRvIII cDNA into these breast cancer cell lines, using various transfection methods or commercially available transfection agents (calcium phosphate precipitation method, lipofectamine, transfectam, and DOTAP) were unsuccessful. Based on these numerous unsuccessful attempts, we conclude that EGFRvIII is likely to be detrimental to cultured human breast cancer cells. This conclusion is supported by the observation that expression of variant forms of EGFR by human gliomas is lost over time with *in vitro* culture, necessitating the propagation of tumors known to express these variant forms of EGFR as xenografts in immunodeficient mice (Bigner, Humphrey et al. 1990). Therefore, I will perform these studies using transiently transfected EGFRvIII-bearing breast cancer cells. We have successfully used a replication-incompetent retroviral vector which efficiently infects and transduces actively proliferating murine and mammalian cells. We expect to achieve similar results with the retroviral vector containing the gene for the human variant of EGFRvIII.

Conclusions

The outcome of these proposed studies will provide very important new methods for treating metastatic breast cancer. In the future, the techniques we propose for the stimulation of a breast cancer patient's immune system to reject a malignancy may lead to clinical therapies allowing the generation of an immune response against the tumor cells such that the patient's own lymphocytes will *selectively* eradicate the malignancy. This immune-based therapy may replace the toxic adjuvant therapies used currently, including chemotherapy and radiation therapy. In addition, these proposed methods for stimulating the immune system against EGFRvIII may provide an actual means of *preventing* breast cancer in susceptible individuals. Thus, the research we have proposed is extremely relevant to the issues of the treatment and prevention of breast cancer.

References

- Batra, S.K., S. Castelinoprabhu, C.J. Wikstrand, X.P. Zhu, P.A. Humphrey, H.S. Friedman and D.D. Bigner (1995). "Epidermal growth factor ligand-independent, unregulated, cell-transforming potential of a naturally occurring human mutant EGFRvIII gene." Cell Growth & Differentiation **6**(10): 1251-1259.
- Bigner, S.H., P.A. Humphrey, A.J. Wong, B. Vogelstein, J. Mark, H.S. Friedman and D.D. Bigner (1990). "Characterization of the epidermal growth factor receptor in human glioma cell lines and xenografts." Cancer Res **50**(24): 8017-22.
- Burnet, F.M. (1970). Immunological Surveillance. Oxford, Pergamon Press.
- Gilboa, E., H.K. Lyerly, J. Vieweg and S. Saito (1994). "Immunotherapy of cancer using cytokine gene-modified tumor vaccines. [Review]." Semin Cancer Biol **5**(6): 409-17.
- Kostelny, S.A., M.S. Cole and J.Y. Tso (1992). "Formation of a bispecific antibody by the use of leucine zippers." J Immunol **148**(5): 1547-53.
- Pai, L.H. and I. Pastan (1994). Immunotoxins and recombinant toxins for cancer treatment. Important Advances in Oncology. V. T. DeVita, S. Hellman and S. A. Rosenberg. Philadelphia, Lippincott Company: 3-19.
- Parker, S.L., T. Tong, S. Bolden and P.A. Wingo (1996). "Cancer statistics, 1996." CA Cancer J Clin **46**(1): 5-27.
- Sussman, J.J., S. Shu, V.K. Sondak and A.E. Chang (1994). "Activation of T lymphocytes for the adoptive immunotherapy of cancer. [Review]." Ann Surg Oncol **1**(4): 296-306.
- Wikstrand, C.J., L.P. Hale, S.K. Batra, M.L. Hill, P.A. Humphrey, S.N. Kurpad, R.E. Mclendon, D. Moscatello, C.N. Pegram, C.J. Reist, S.T. Traweek, A.J. Wong, M.R. Zalutsky and D.D. Bigner (1995). "Monoclonal antibodies against EGFRvIII are tumor specific and react with breast and lung carcinomas and malignant gliomas." Cancer Research **55**(14): 3140-3148.
- Yon, J. and M. Fried (1989). "Precise gene fusion by PCR." Nucleic Acids Res **17**(12): 4895.



DEPARTMENT OF THE ARMY
US ARMY MEDICAL RESEARCH AND MATERIEL COMMAND
504 SCOTT STREET
FORT DETRICK, MARYLAND 21702-5012

Rec'd
7/19/2000

REPLY TO
ATTENTION OF:

MCMR-RMI-S (70-1y)

6 Jul 00

MEMORANDUM FOR Administrator, Defense Technical Information
Center, ATTN: DTIC-OCA, 8725 John J. Kingman
Road, Fort Belvoir, VA 22060-6218

SUBJECT: Request Change in Distribution Statements

1. The U.S. Army Medical Research and Materiel Command has reexamined the need for the limitation assigned to technical reports written for the following awards:

DAMD17-94-C-4068	ADB218322
DAMD17-94-V-4036	ADB232944
DAMD17-94-J-4481	ADB222571
DAMD17-95-C-5054	ADB227112
DAMD17-96-1-6016	ADB228823
DAMD17-96-1-6073	ADB248567
DAMD17-94-J-4057	ADB221437, ADB247857
DAMD17-96-1-6069	ADB230256, ADB239319
DAMD17-95-1-5067	ADB236775, ADB249592
DAMD17-94-J-4308	ADB225776, ADB234457, ADB249935
DAMD17-96-1-6087	ADB232086, ADB238945, ADB250354
DAMD17-96-1-6075	ADB228777, ADB238338, ADB249653
DAMD17-95-1-5008	ADB225250, ADB236089, ADB243691
DAMD17-94-J-4310	ADB222453, ADB235860, ADB247801

Request the limited distribution statement for Accession Document Numbers be changed to "Approved for public release; distribution unlimited." These reports should be released to the National Technical Information Service.

2. Point of contact for this request is Ms. Virginia Miller at DSN 343-7327 or by email at Virginia.Miller@det.amedd.army.mil.

FOR THE COMMANDER:

Phyllis Rinehart
PHYLLIS M. RINEHART
Deputy Chief of Staff for
Information Management