

AD _____

Award Number: DAMD17-97-C-7042

TITLE: 3D Real Time Surgical Simulator

PRINCIPAL INVESTIGATOR: Alan Sullivan, Ph.D.

CONTRACTING ORGANIZATION: Dimensional Media Associates, Incorporated
New York, New York 10011

REPORT DATE: April 2001

TYPE OF REPORT: Final

PREPARED FOR: U.S. Army Medical Research and Materiel Command
Fort Detrick, Maryland 21702-5012

DISTRIBUTION STATEMENT: Distribution authorized to U.S. Government agencies only (proprietary information, Apr 01). Other requests for this document shall be referred to U.S. Army Medical Research and Materiel Command, 504 Scott Street, Fort Detrick, Maryland 21702-5012.

The views, opinions and/or findings contained in this report are those of the author(s) and should not be construed as an official Department of the Army position, policy or decision unless so designated by other documentation.

**Reproduced From
Best Available Copy**

20010716 097

NOTICE

USING GOVERNMENT DRAWINGS, SPECIFICATIONS, OR OTHER DATA INCLUDED IN THIS DOCUMENT FOR ANY PURPOSE OTHER THAN GOVERNMENT PROCUREMENT DOES NOT IN ANY WAY OBLIGATE THE U.S. GOVERNMENT. THE FACT THAT THE GOVERNMENT FORMULATED OR SUPPLIED THE DRAWINGS, SPECIFICATIONS, OR OTHER DATA DOES NOT LICENSE THE HOLDER OR ANY OTHER PERSON OR CORPORATION; OR CONVEY ANY RIGHTS OR PERMISSION TO MANUFACTURE, USE, OR SELL ANY PATENTED INVENTION THAT MAY RELATE TO THEM.

LIMITED RIGHTS LEGEND

Award Number: DAMD17-97-C-7042
Organization: Dimensional Media Associates, Incorporated

Those portions of the technical data contained in this report marked as limited rights data shall not, without the written permission of the above contractor, be (a) released or disclosed outside the government, (b) used by the Government for manufacture or, in the case of computer software documentation, for preparing the same or similar computer software, or (c) used by a party other than the Government, except that the Government may release or disclose technical data to persons outside the Government, or permit the use of technical data by such persons, if (i) such release, disclosure, or use is necessary for emergency repair or overhaul or (ii) is a release or disclosure of technical data (other than detailed manufacturing or process data) to, or use of such data by, a foreign government that is in the interest of the Government and is required for evaluational or informational purposes, provided in either case that such release, disclosure or use is made subject to a prohibition that the person to whom the data is released or disclosed may not further use, release or disclose such data, and the contractor or subcontractor or subcontractor asserting the restriction is notified of such release, disclosure or use. This legend, together with the indications of the portions of this data which are subject to such limitations, shall be included on any reproduction hereof which includes any part of the portions subject to such limitations.

THIS TECHNICAL REPORT HAS BEEN REVIEWED AND IS APPROVED FOR PUBLICATION.

REPORT DOCUMENTATION PAGEForm Approved
OMB No. 074-0188

Public reporting burden for this collection of information is estimated to average 1 hour per response, including the time for reviewing instructions, searching existing data sources, gathering and maintaining the data needed, and completing and reviewing this collection of information. Send comments regarding this burden estimate or any other aspect of this collection of information, including suggestions for reducing this burden to Washington Headquarters Services, Directorate for Information Operations and Reports, 1215 Jefferson Davis Highway, Suite 1204, Arlington, VA 22202-4302, and to the Office of Management and Budget, Paperwork Reduction Project (0704-0188), Washington, DC 20503

1. AGENCY USE ONLY (Leave blank)	2. REPORT DATE April 2001	3. REPORT TYPE AND DATES COVERED Final (25 Sep 97 - 31 Mar 01)
----------------------------------	------------------------------	---

4. TITLE AND SUBTITLE 3D Real Time Surgical Simulator	5. FUNDING NUMBERS DAMD17-97-C-7042
--	--

6. AUTHOR(S) Alan Sullivan, Ph.D.

7. PERFORMING ORGANIZATION NAME(S) AND ADDRESS(ES) Dimensional Media Associates, Incorporated New York, New York 10011 E-Mail: as@3dmedia.com
--

8. PERFORMING ORGANIZATION REPORT NUMBER
--

9. SPONSORING / MONITORING AGENCY NAME(S) AND ADDRESS(ES) U.S. Army Medical Research and Materiel Command Fort Detrick, Maryland 21702-5012

10. SPONSORING / MONITORING AGENCY REPORT NUMBER
--

11. SUPPLEMENTARY NOTES This report contains colored photos
--

12a. DISTRIBUTION / AVAILABILITY STATEMENT Distribution authorized to U.S. Government agencies only (proprietary information, Apr 01). Other requests for this document shall be referred to U.S. Army Medical Research and Materiel Command, 504 Scott Street, Fort Detrick, Maryland 21702-5012.

12b. DISTRIBUTION CODE

13. ABSTRACT (Maximum 200 Words) The purpose of this program of research was the development of a high performance Multiplanar Volumetric 3D Display (MVD) to serve as the primary information display for an Advanced Volumetric Surgical Simulator (AVSS). The future AVSS will combine together a Multiplanar Volumetric Display with a pair of force feedback haptic interfaces to form a general purpose tactile task simulation platform upon which to run a wide range of surgical simulation software. The MVD is a true 3D display which produces full color, images having all of the visual attributes of real objects. This research effort was successful in nearly all of its goals which included development of new display materials, extension of the compatible computer platforms, improvement to the programming interface, and development of a custom high speed video projector. Minor shortfalls in performance of a key component of the video projector mandate that an additional prototype generation will be required before commercialization of the MVD technology can take place. This final generation has been funded through internal funds and is nearing completion as of the date of this report. Commercialization of the MVD technology will allow the development of the AVSS as well as many other military and civilian 3D display applications.

14. SUBJECT TERMS 3D, display, volumetric, multiplanar, three-dimensional
--

15. NUMBER OF PAGES 152
16. PRICE CODE

17. SECURITY CLASSIFICATION OF REPORT Unclassified

18. SECURITY CLASSIFICATION OF THIS PAGE Unclassified
--

19. SECURITY CLASSIFICATION OF ABSTRACT Unclassified

20. LIMITATION OF ABSTRACT Unlimited

Table of Contents

Cover	
SF 298.....	2
Table of Contents.....	3
I. Introduction	4
II. Body	4
A. TASK 5a – MVD API software	7
B. TASK 4 – High Speed Data Link to Image Source.....	9
C. TASK 3 – High Frame Rate Image Source.....	9
C.1. MVD Framebuffer Electronics	9
C.2. Projection Engine.....	11
C.3. Spatial Light Modulator	14
D. TASK 1 – MOE Improvements	17
E. TASK 5b – MVD Integration.....	19
F. TASK 2 – Volumetric Floating Image Projector.....	22
III. Key Research Accomplishments.....	22
IV. Reportable Outcomes.....	23
V. Conclusions	23
VI. References	24
VII. Appendices	25
A. MVD API Source Code	
B. MVD data word format	
C. Data transfer cable pin assignments	
D. SGI Device Driver source code	
E. Framebuffer schematics	
F. Vacuum chamber mechanical drawings	
G. Cell press mechanical drawing	
H. MOE Driver Schematics	

I. INTRODUCTION

The purpose of this program of research was the development of a high performance Multiplanar Volumetric 3D Display (MVD) to serve as the primary information display for an Advanced Volumetric Surgical Simulator (AVSS). The future AVSS will combine together a Multiplanar Volumetric Display with a pair of force feedback haptic interfaces to form a general purpose tactile task simulation platform upon which to run a wide range of surgical simulation software. The goal of this research was to develop, integrate and demonstrate the components and software application programming interface (API) of the MVD.

II. BODY OF REPORT

A Multiplanar Volumetric Display is a true three dimensional display system that creates images having all of the viewing characteristics of real objects. Figure 1 shows a schematic diagram of the MVD. The MVD is essentially a rear projection 3D display. The overall system consists of a computer connected through a high speed data link to an external 3D framebuffer. The framebuffer in turn feeds data at a high rate to a high speed video projector. The images from the video projector are projected into an electronic variable-depth projection volume known as the Multiplanar Optical Element (MOE). The MOE converts the high speed stream of 2D images from the video projector into a single 3D image by stopping each 2D image at the appropriate depth. Proprietary Multiplanar Anti-aliasing algorithms smooth the transitions between image slices to create continuous appearing 3D images. The resulting 3D image can be viewed directly within the MOE, just like looking at fish in a fish tank, or may be projected out into free space by a real image projection optical system. The projected image is free from the volume of the MOE and, therefore, can be touched, felt and interacted with via a co-aligned haptic interface, making development of a surgical simulator, or other tactile task trainer, possible.

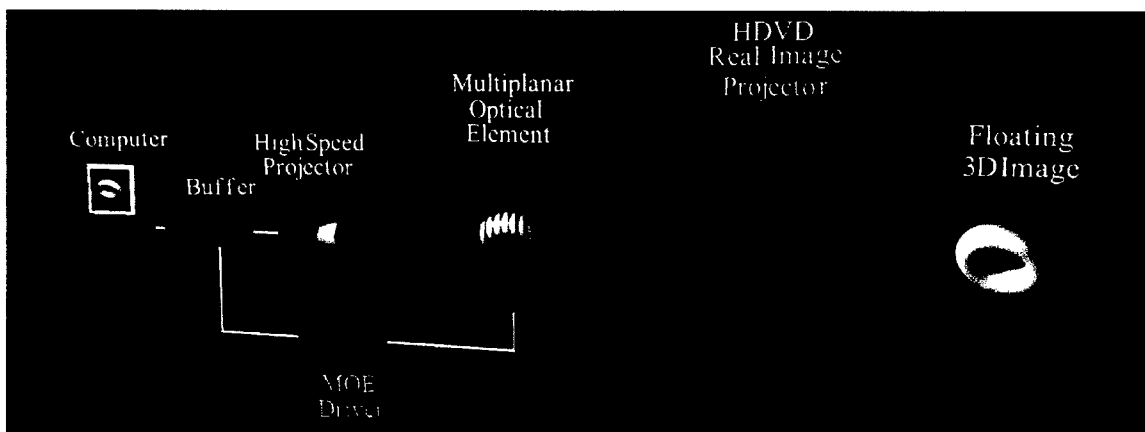

Figure 1. Schematic diagram of the Multiplanar Volumetric 3D Display showing the computer system feeding data to the high speed projector whose sequence of 2D image slices are converted to a 3D image by the Multiplanar Optical Element. The real image projector, in turn, creates a floating image.

The three dimensional image created by the Multiplanar Volumetric Display is truly 3D, not an optical illusion. The points of light that compose the image (voxels) are actually located in space where they appear. This means that 3D images created by a Multiplanar Volumetric Display have all of the characteristics of real objects. They have a wide field of view, and can be "looked around", in both the horizontal and vertical directions. They require the viewer's eyes to correctly alter focus and convergence as their gaze shifts from the front to the back of the image. The 3D image is visible to a number of viewers at any distance, each with the appropriate perspective view. Unlike other volumetric display systems, the HyperCube has no moving parts, does not generally require laser light, and is highly compatible with existing display components and manufacturing methodologies. This last point is critical to rapidly transition the technology from Research and Development to commercial manufacturing and sales.

A number of key component requirements emerge from the preceding description. The high speed video projector must be fast enough to project the 2D images slices that make up the 3D image at a rate high enough to avoid image flicker in the 3D image. And the MOE planes must be highly transparent in the transparent state, high scattering in the scattering state, and make rapid and clean transitions between these two states.

There will be references throughout this document to the refresh rate, field rate and update rate of the display. The refresh rate is the rate at which the entire volume image is produced. This rate must be greater than 35 Hz, and preferably at least 50 Hz, to avoid image flicker. The field rate is the rate at which each 2D image slice, or field, is projected into the MOE. For example, in a 12 plane MVD operating at a refresh rate of 41.7 Hz requires a field rate of 500 Hz. The update rate is the rate at which new 3D content can be transferred from the computer to the MVD. For realistic and responsive visual simulator this rate must be at least 15 Hz, but preferably greater than 30 Hz.

Table 1 lists the performance specifications of the prototype Multiplanar Volumetric Display developed under this program. Overall the project was very successful. There were nine distinct improvements in the MVD technology over the previous generation. These were:

- a. Development of both SGI and PC interface capabilities
- b. Development of the MVD Application Programming Interface (API) software
- c. Identification and adoption of a high speed data transfer interface technology
- d. Development of a custom MVD framebuffer incorporating Multiplanar Anti-aliasing in hardware
- e. Customization of analog ferroelectric liquid crystal on silicon (aFLCoS) spatial light modulators for use in a high speed video projector
- f. Development of a projection engine architecture to convert the spatial light modulator into a video projector
- g. Development of improved MOE materials

- h. Development of large MOE cells
- i. Development of a MOE driver

Of all of these improvement, only the customization of the light modulator reached less than 100% of its performance goals. This component is a 512 x 512 pixel analog ferroelectric liquid crystal on silicon (aFLCoS) spatial light modulator from Boulder Nonlinear Systems, Inc. (Boulder, CO) capable of 500 DC-balanced fields per second. As will be discussed further in section C.3, the development of the custom aFLCoS SLM was the most difficult and time consuming task of the project and led to an appreciable extension of its duration. Ultimately, the performance of this component, in terms of uniformity and contrast ratio, had a significant negative impact on the visual performance of the MVD, leading to another iteration of display development before DMA can commercialize the MVD technology. The performance issues of the SLM will be discussed in greater detail in section C.3.

MVD Transverse resolution	512 x 512 pixels
Light modulator	Analog Ferroelectric Liquid Crystal on Silicon (aFLCoS)
Color depth	21-bits (2,097,152 colors)
Number of MOE planes	12
Total number of image voxels	3.14 million
Image volume	15" x 13" x 3.1"
Image refresh rate	41.7 Hz
Image update rate (plane transfer)	14 Hz

Table 1. Performance specifications of the Multiplanar Volumetric Display developed under this project.

Statement of Work from Original Proposal

The statement of work from original proposal described the following tasks:

Task 1 – MOE improvements

The MOE optical and electrical characteristics will be improved with particular attention paid to issues of clear state transparency, off-axis haze and switching speed. The research will focus on improvements in the PDLC materials for the MOE.

Task 2 – Volumetric real image projector

A carefully designed volumetric projection system will be engineered to provide optimal characteristics for the application of projecting three dimensional images from the MOE. Field of view and ergonomic consideration will be addressed.

Task 3 – High Frame Rate Image source (video projector) development

DMA will develop a high frame rate image source based upon Texas Instruments Digital Light processing (DLP) technology. The image source will be required to produce images of at least 15-bit color, with a frame rate greater than 1,000 field per second. The architecture of the DLP engine will be redesigned to permit direct integration with a high performance graphics computer digital interface.

Task 4 – High speed data link

DMA will develop high speed three-dimensional image processing hardware and software based upon Silicon Graphics hardware to deliver data to the high frame rate image source. The task will involve transforming a three-dimensional OpenGL data set into a multiplanar data set and delivering the information to the image source in real-time. It also involves the design and construction of a high bandwidth interface between the computer system and the image source.

Task 5 – MVD API software and display integration

Integration will consist of physically connecting the computer system and the high frame rate image source, establishing proper communications, and integrating software elements.

It is conceptually more understandable to discuss the results of this work in the order of the data flow from computer to the viewer, rather than in the order given above.

A. TASK 5a – MVD API software

The MVD can be driven by either a personal computer (PC) running the Window NT 4.0 operating system or by a Silicon Graphics workstation. The PC currently used is a Dell computer with dual 833 MHz Pentium III processors and equipped with a Nvidia GeForce2 3D graphics card that is controlled through the standard OpenGL graphics API. The SGI workstation is an Octane SSI with dual 195 MHz R10000 RISC processors and a PCI card interface.

The MVD application programming interface (API) is a library of routines used to add MVD functionality to computer source code. The MVD API was written for the PC in Pascal using Borland's Delphi IDE (see Appendix A) and in C++ for the SGI. It consists of the following commands:

a. *mvdSet_state* – sets the operating parameters of the MVD including the number of planes, transverse resolution of each plane, and a range of flags to control various MVD operating modes.

b. *mvdInit* - initializes both internal memory space and the high speed data transfer card.

c. *mvdReadgl* - reads the color and z-buffer data from the graphics processor's framebuffer back into main memory.

d. *mvdFormat_data* - combines the separate color and z-buffer data into a 32-bit word per pixel (see Appendix B for details of the 32-bit data word format).

e. *mvdTransfer* - performs handshaking with the framebuffer electronics to confirm readiness to receive data and, if confirmed, initiates the data transfer by the data transfer card and then monitors the process for completion.

f. *mvdClose* - frees internal memory space and shuts down the data transfer card.

The API functions, *mvdSet_state* and *mvdInit*, are generally called during an application's initialization phase. *mvdSet_state* is an overloaded function that takes as input a parameter flag and a parameter value. It is called at least three times to initialize the MVD state variables defining the number of MOE planes, and the transverse display resolution. Following the calls to *mvdSet_state*, *mvdInit* is called to initialize the MVD hardware. *mvdInit* returns an integer to indicate either success or the reason for initialization failure. Future API releases will write the MVD hardware parameters (number of planes, and transverse resolution) to the MS Windows registry during installation.

3D images for the MVD are created in the computer in the standard way. The programmer defines 3D polygonal surfaces, texture maps, color and lighting models through conventional OpenGL calls. The result is a 2D image on the computer monitor that is created by the graphics hardware through its rendering processor. Associated with the image on the monitor is both the color data and an associated depth map (z-buffer) in the framebuffer of the graphics hardware. The z-buffer has the same x, y resolution as the color image and is the depth, in scaled coordinates, of each pixel in the color image.

The API functions, *mvdReadgl*, *mvdFormat_data*, and *mvdTransfer* are called following the end of the conventional rendering process. In OpenGL this occurs after the *glSwapBuffers* command is issued. These MVD API commands are called in sequence to create an image in the MVD. Following the return from *mvdTransfer*, the entire rendering process can begin again. Given the explicit nature of writing images to the MVD it can be updated as frequently or infrequently as the programmer may desire.

It should be noted that the choice of the 3D graphics card can strongly affect the display update rate by affecting how long it takes to transfer data from the framebuffer back to main memory. Although any OpenGL graphics card can be used not all graphics cards will provide good update rates. The Nvidia GeForce2 graphics card currently in use can transfer both the color and depth framebuffer data from a 512 x 512 window to main memory in 11.7 msec, more than fast enough for realtime simulation. The framebuffer read back time can vary widely depending on the choice of graphics card.

Two different data transfer modes from computer to MVD are currently supported by both hardware and API. These are plane mode and block mode, and are established through the *mvdSet_state* function. In plane transfer mode the number of data words

transferred to the MVD is equal to the number of pixels in a single 2D image slice, 512 x 512 in the current hardware. The pixels are sent in order from the top, left to the bottom, right with each data word giving the RGB color and depth of each pixel, with the depth scaled by the API to be a fixed point value in the range from 0 to N_{Planes} . The depth data is used by the input processor of the framebuffer to determine the MVD plane, or planes, on which the data belongs. In this way only one voxel at any depth at a particular x, y location is illuminated. The result is 3D image that is either a single 3D surface, a 3D wireframe, or a 3D point cloud. Multiple 3D surfaced images cannot be produced in plane transfer mode.

In block transfer mode, the data for every voxel in the display is transferred from the computer to the display, including voxels whose color is black. In the current prototype, this constitutes the transfer of 512 x 512 x 12 data words, obviously taking 12 times longer to transfer to the display than a plane transfer mode image. In block mode, the depth information in the data words is ignored since the ordering of data words determines their x, y and z location within the display. Block mode allows multi-surface 3D images and space filling volumetric data, such as MRI or CT data, to be displayed in the MVD.

B. TASK 4 - High Speed Data Link to Image Source

A high speed data transfer card from National Instruments, Inc. (Austin, TX) is used to transfer 3D images to the MVD. This card (PCI-DIO-32HS) is capable of directly reading data out of main memory through a process known as direct memory access (DMA), and can transfer 32-bit parallel data words from the computer to a framebuffer at up to 76 MBytes per second. Accordingly, the card can transfer a plane transfer mode image from the computer to the framebuffer in 13.7 milliseconds, and a block mode formatted 512x512x12 voxel image in 164 milliseconds. Appendix C gives the pin assignments for the connection between the data transfer card and the MVD framebuffer.

The data transfer card is available with device drivers for both Apple Macintosh computers and Wintel PCs. An objective of this project was to enable the MVD to also operate with Silicon Graphics workstations. Therefore, a device drive was written by DMA to provide this additional connectivity. The source code of the device driver is attached as Appendix D.

C. TASK 3 - High Frame Rate Image Source

The high frame rate image source consists of an external multiplanar framebuffer and the high speed video projector. The video projector consists of the spatial light modulator and the optical projection engine, which is further sub-divided into the illumination subsystem, color separation optics, color combination optics and projection lens..

C.1. MVD framebuffer electronics

The MVD framebuffer was custom developed by DMA for this project. It is shown conceptually in figure 2 and complete framebuffer schematics are included in Appendix

E. It consists of three identical printed circuit boards, one for each color channel of the high speed video projector. The cable from the data transfer card terminates on the red framebuffer board which has been designated as the master controller. The green and blue brightness data and the depth data is transferred from the red board to the green and blue slave boards through two short cables identical to the input cable. Data clock, input, and output synchronization signals are sent from the red board to the green and blue boards through BNC cables.

Each board consists of an input processor, multiplanar framebuffer and output drivers. The input processor is a field programmable gate array (FPGA) that receives the pixel data from the data transfer card, performs multiplanar antialiasing on the pixel data (more on this later) and then places the processed data into the multiplanar framebuffer. The multiplanar framebuffer consists of 25 Mbytes of dual ported memory arranged in a double buffer architecture. The double buffered architecture allows one 12.5 MByte sub-buffer to be written while the other sub-buffer is being displayed, and permits a high display refresh rate in the presence of a lower and variable 3D image update rate. Essentially, the framebuffer receives data from the computer serially at 76 Mbytes/sec and outputs it in parallel to the video projector at a rate of 1000 Mbytes/sec/color. The framebuffer is large enough to hold 50 two dimensional images, each 512 x 512 pixels and 21-bit color.

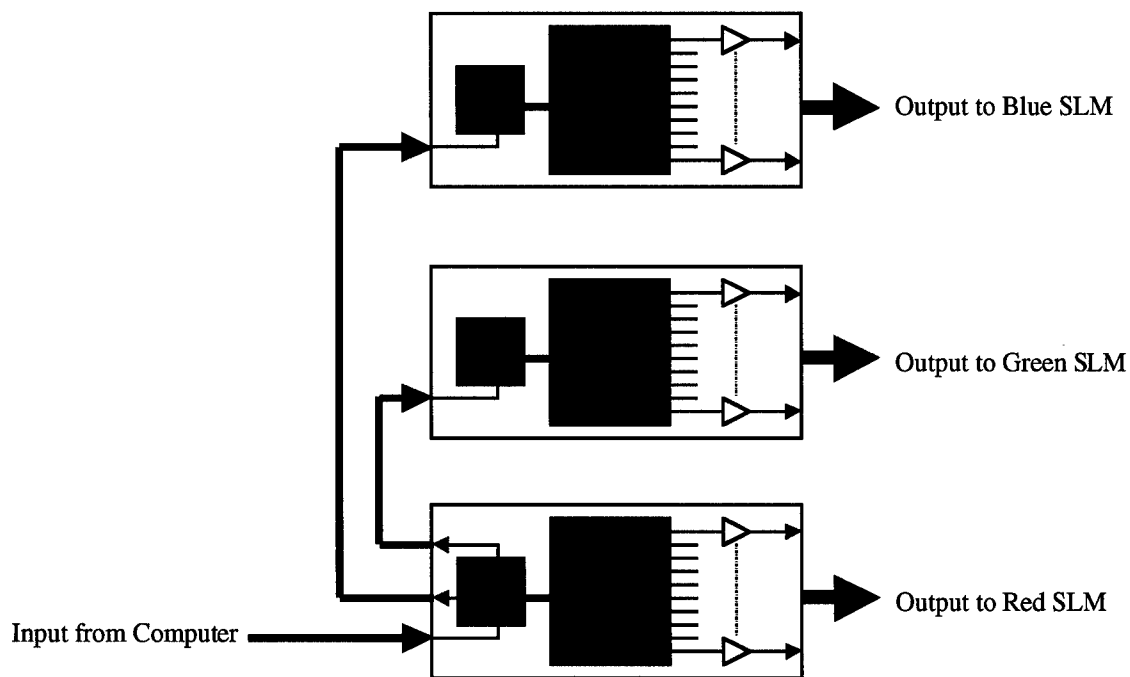

Figure 2. Schematic diagram of MVD framebuffer consisting of three identical boards, one for each color. The red board acts as the master and transfers brightness, depth and synchronization signals to the green and blue boards. IP is the input processor, FB is the framebuffer.

The output driver section of each board consists of 32 digital-to-analog converters (DAC) arranged in parallel, each delivering data to a 16 column x 512 row sub array of the light modulator of the high speed video projector. The DACs are equipped with internal RAM that is used as a look-up-table (LUT) used to linearize the nonlinear

voltage to brightness transfer function of the aFLCoS spatial light modulators. The DAC receives an 7-bit brightness value from the MVD framebuffer, uses it as an address to retrieve a 10-bit value from the LUT, then converts the 10-bit value to a current in the range of 0 milliamps to 13.62 milliamps. The current signal from the DACs is delivered to each SLM through a 100 conductor ribbon cable that terminates in a small printed circuit board. The board has 8 quad op-amps that are configured as current to voltage converters. The resulting voltage range is 0 volts to 4.32 volts. These voltages are applied to the input pins of the SLM. Current signals, rather than voltage, are used to provide a high level of noise immunity. The data clock to the DACs is 33 MHz.

Although the 3D image within the MOE actually consists of a stack of discrete 2D image slices, the image can be made to appear continuous through the use of a processing algorithm developed previously by DMA called multiplanar anti-aliasing. Multiplanar anti-aliasing eliminates the abrupt transitions between MVD image slices by effectively creating voxels that appear to the viewer to be between two MOE planes.

To use multiplanar anti-aliasing the voxel depth data is transferred to the framebuffer as a fixed point number consisting of a 6-bit integer portion and a 5-bit fractional portion. The integer portion determines the pair of planes on which the brightness data is written and the fractional portion determines their relative brightness'. For example, if the integer portion is 5 the brightness data will be written to planes 5 and 6. If the fractional part is 0 then 100% of the brightness is on plane 5 and 0% of the brightness is on plane 6. If the fraction part is 16 then 50% of the brightness is on plane 5 and 50% on plane 6. For the maximum fractional value of 31, plane 5 gets 1/32, or 3.1% and plane 6 gets 31/32, or 96.9%.

The antialiasing calculation is carried out on-the-fly by the input processor. For each data value transferred the brightness and the fractional value of the depth is used to compute two new brightness values. These values are written to the portions of the framebuffer memory determined by integer portion of the depth value.

C.2. Projection Engine

The original design for the projection engine of the high speed video projector is shown schematically in figure 3 and the final design is shown in figure 4. The original design employed a 500 Watt Cermax Xenon arc lamp (Model # EX500-13F) from ILC Technology (Sunnyvale, CA, now a division of EG&G) as the light source and is similar to the design described in reference 1. The light from the arc lamp is focused on an 8 mm x 8 mm x 100 mm BK7 integrating rod to produce uniform illumination. The light from the output face of the integrating rod is relayed to the light modulators by relay lenses 1 and 2 and the field lenses. Along the way the light is split by dichroic mirrors from OCLI (Santa Rosa, CA) into red, green and blue channels. These are routed by turning mirrors toward the appropriate light modulator. After passing through the field lens the light is incident on a wide bandwidth, wide angle polarizing beam splitter (PBS) from OCLI. The vertically polarized component of the light is reflected 90° by the PBS, passes through a zero-order half wave plate from Newport Corp. (Irvine, CA), and illuminates the light modulator with an image of the end of the integrator rod. The half wave plate allows the

polarization axis of the light to be rotated for optimization of the light modulator contrast ratio. The light modulator reflects the light back toward the PBS and rotates the polarization depending on the voltage supplied to each pixel. Rotation by 90° cause the light to be transmitted by the PBS toward an x-cube beam combiner from Balzers Thin Films (Golden, CO). The x-cube combines red, green and blue light entering through three faces into a single full color beam exiting the fourth face. This light is imaged by a 55 mm F.L., 100 mm B.F.L., F/2.5 projection lens from Buhl Systems. The large back focal length provides the space needed for the x-cube and the PBS between the SLM and the projection lens. The projection lens can be focused between 0.5 meters and 5 meters thereby accommodating a wide range of MOE sizes.

Each light modulator is illuminated by a uniform 8 mm x 8 mm light beam having an FWHM angular range of $\pm 15^\circ$ (F/1.9) and a bandwidth of approximately 90 nm centered at 455 nm for the blue, 545 nm for the green and 635 nm for the red.

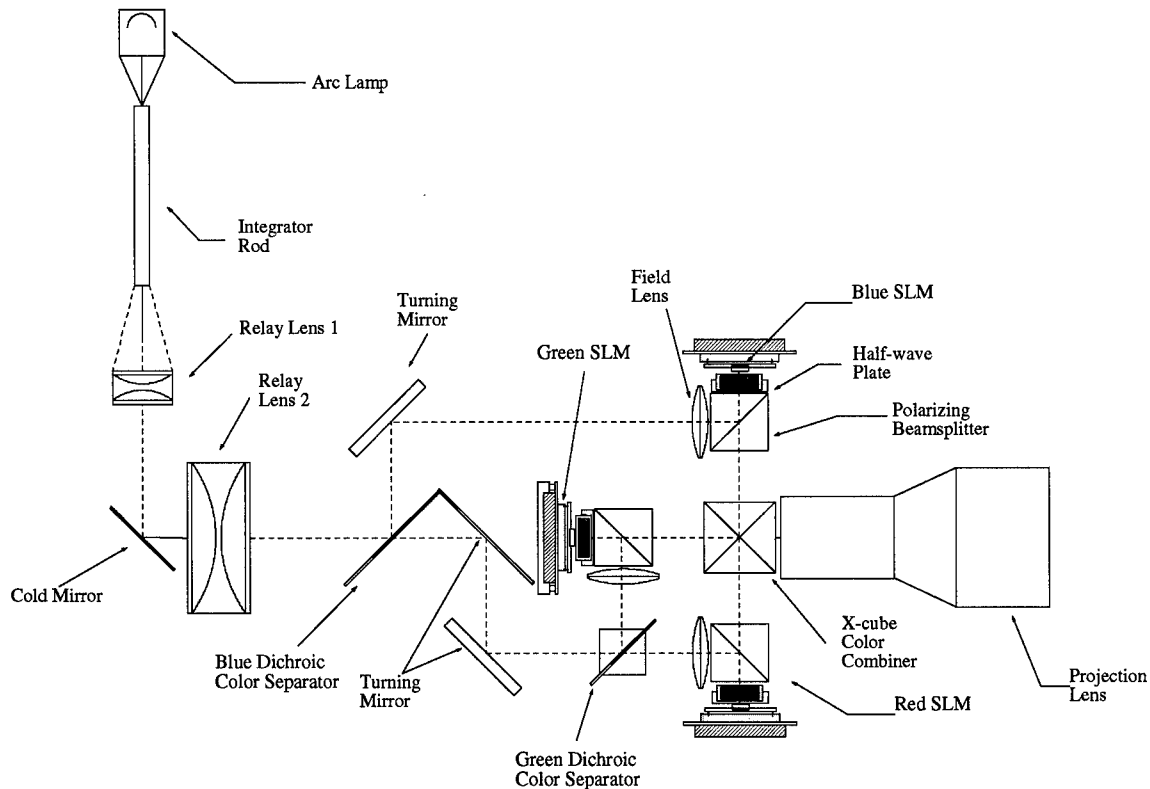

Figure 3. Schematic diagram of the original design of the high speed video projector. The heart of the illumination system is a 500 watt Cermax xenon arc lamp.

Limitations in the performance of the spatial light modulator when illuminated by broad band, low F/# light forced the redesign of the projection engine to that shown in figure 4. These limitations, described in section C.4 caused the 3D images produced by the original design to have low contrast in the range of 30:1. By comparison, the contrast of commercial video projectors is in the range of 400:1.

The design of figure 4 has the same PBS, half wave plates, x-cube color combiner and projection lens as the original, but has the arc lamp based illumination sub-system replaced by one that uses collimated, monochromatic laser light to illuminate the light modulator.

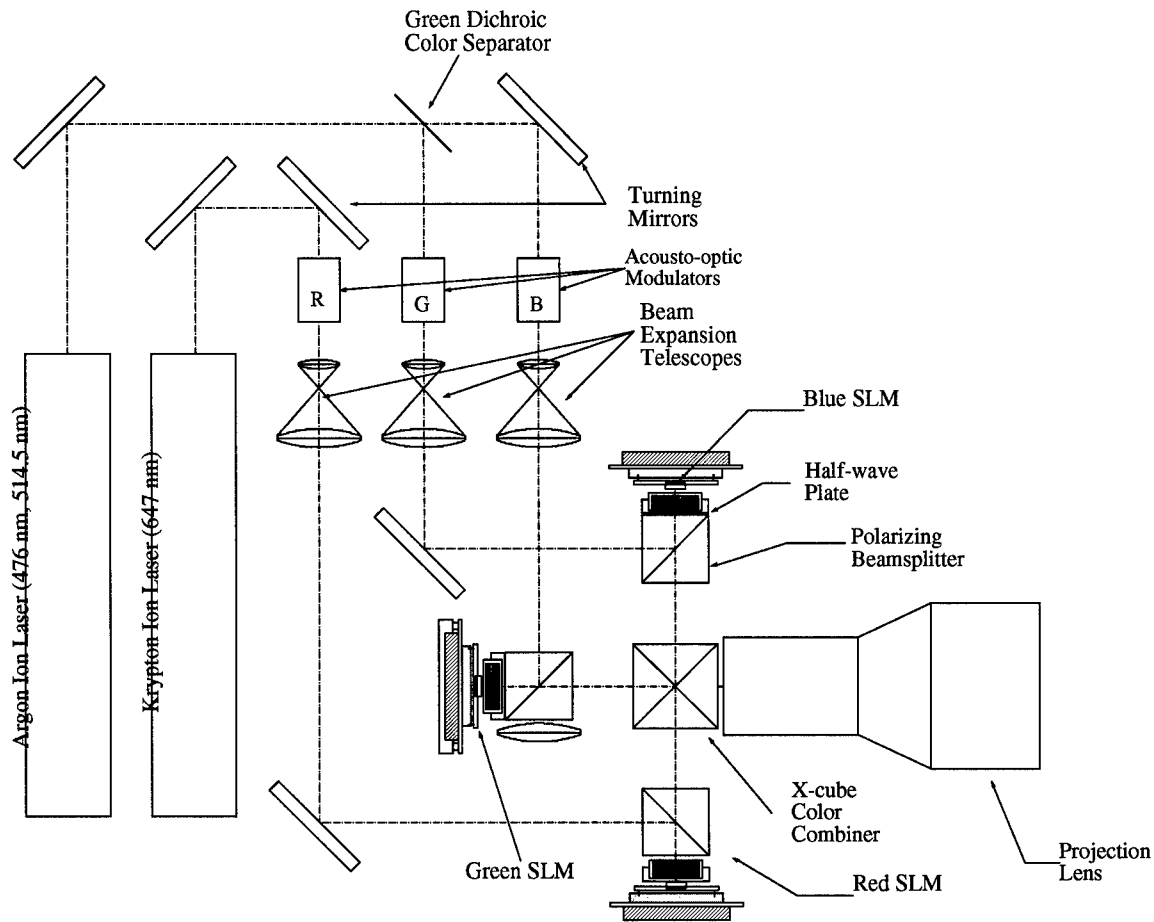

Figure 4. Schematic diagram of the final design of the high speed video projector. The original Cermax xenon arc lamp has been replaced by lasers to provide illumination.

Full color illumination is provided by a combination of an argon ion laser, simultaneously emitting green light (514.5 nm) and blue light (476 nm), and a krypton ion laser that emits red light (647 nm). The system also employs an acousto-optic light modulator for each color to blank the laser light during the 60% of the field period associated with DC-balancing of the light modulator. The result was a dramatic improvement to the projector contrast ratio to over 250:1 for the green and red channels and over 150:1 for the blue channel, adequate to demonstrate the feasibility of the rest of the display design, but inadequate for commercialization. Again the limitation in performance is caused by the spatial light modulators.

C.3. Spatial Light Modulator

The original statement of work indicated that DMA would attempt to use the Texas Instruments' DLP light modulator technology in the prototype MVD. Unfortunately, at the time TI did not allow third parties to develop modified versions of its DLP technology for novel applications, thereby preventing its use in the MVD. Fortunately, a reasonable replacement technology was identified from Boulder Nonlinear Systems, Inc. (BNS, Boulder, CO).

The three spatial light modulators in the high speed video projector are custom components developed by BNS for this project. They are reflective liquid crystal on silicon (LCoS) light modulators in which a silicon wafer is fabricated through CMOS processing into an 2D array of reflective aluminum pixel electrodes with associated storage capacitors and electronic switches to form a silicon backplane (ref. 2, 3). Onto this backplane is applied a liquid crystal alignment layer (often rubbed polyimide), a 2-5 micron thick layer of liquid crystals, and a cover glass with a transparent conductive layer of indium tin oxide (ITO) to serve as a counter electrode. The maturity and resolution of CMOS processing allows a large number of backplanes to be produced simultaneously on a silicon wafer, each with a large number of pixels (up to 2400 x 2048) with small sizes (down to 5 microns) and with a high fill factor (up to 95%) to be fabricated at low cost and with high yield.

Although conventional LCoS light modulators, such as those from Three Five Systems, Inc., may use the type of nematic liquid crystal found in LCDs, these are far too slow (~ 10 msec) for the high field rate requirements of the MVD (~100 microseconds). BNS produces LCoS light modulators that use ferroelectric liquid crystals aligned in such a way as to produce analog grayscale optical modulation as a function of pixel electrode voltage.

There are a number of important requirements for LCoS light modulators that are used in video projectors (ref. 4). They must have a high fill factor (the fraction of a pixel's area that reflects light) in order to provide a high optical efficiency. The aluminum used for the pixel electrodes must be optically flat in addition to being a good conductor so that there will be a good specular reflection. The entire CMOS die of the light modulator must be globally flat (planarized) to within a fraction of a wavelength of light to provide a uniform thickness of the liquid crystal layer. And the CMOS circuitry under the pixel electrode array must be shielded from illumination by the incident light which would otherwise cause the pixel voltages to be discharged.

At the beginning of this project BNS had an existing analog ferroelectric spatial light modulator that was used for optical computing applications. Because they are not intended for projection applications, these SLMs have a low fill factor, rough aluminum pixel electrodes, and poor die planarity. BNS was involved in a project to apply a sacrificial layer to the top of these die, planarize the sacrificial layer, and then apply a spatially registered array of high reflectance, high fill factor pixel electrodes. DMA was going to procure three of these SLMs to use in the MVD high speed video projector.

Unfortunately, the effort was not successful as the resulting SLMs were not only not highly reflective and well planarized, but did not function electrically.

DMA then contracted with BNS to develop a custom analog ferroelectric LCoS SLM having the projector component characteristics described above as the starting principles of the CMOS design. The resulting design was then fabricated at a CMOS silicon foundry into five 8" diameter wafers containing a total of roughly 1500 usable die. Each die has 512 x 512 pixels on 15 micron centers with an 85% fill factor with the pixel electrode area occupying 7.68 mm x 7.68 mm. After dicing a wafer into individual die, the final SLM is completed as described above. Figure 5 shows microphotographs of the one of the SLM die as it appears on the 8" silicon wafer.

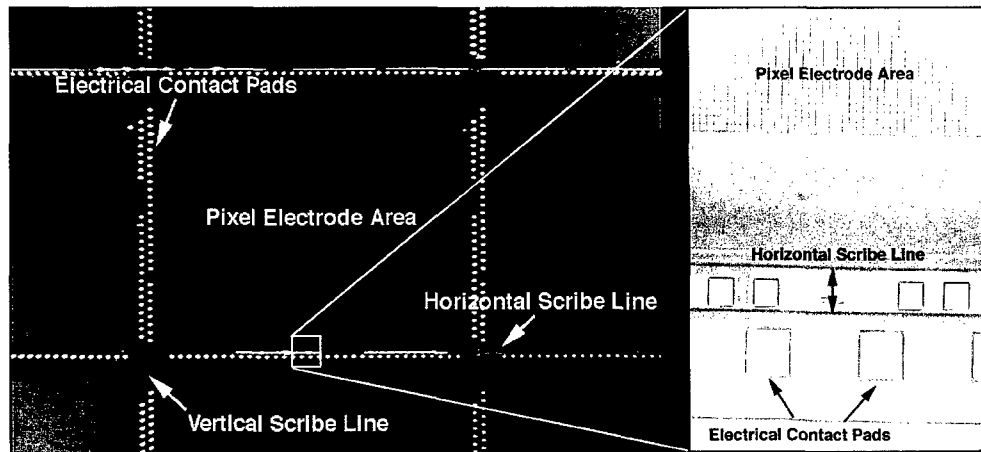

Figure 5. Microphotographs of the 8" wafer of CMOS silicon backplanes of the BNS custom analog ferroelectric light modulator. The image on the left shows several adjacent SLM die while the image on the right is a zoom in of the indicated area showing the individual 15 micron pixel electrodes. The color in the right hand image is an artifact of the microscope.

A number of custom aFLCoS light modulators were evaluated before identifying three components that provided good performance at the red, green and blue laser wavelengths used. Graphs of their optical signal versus SLM pixel voltage are shown in figure 6. In each case the half wave plate angle is adjusted to provide the best overall black level at some pixel voltage. The data is then used to compute LUT that is loaded into the framebuffer DACs in order to linearize the optical signal as a function of the digital grayscale value from the computer.

The final image of the high video projector and hence the MVD was found to suffer from the relatively low contrast ratio and low uniformity of the BNS SLMs. These problems are caused by an insufficient uniformity of the alignment of the liquid crystals that is, in turn, is caused by insufficient planarization of the silicon backplane. This type of problem is common in LCoS light modulators (ref. 4) and is caused by the unavoidable non-uniformity of the density of the semiconductor structures created during CMOS photolithography. The pixel array area of the SLM has a high density of structures whereas the shift registers at the periphery of the pixel array have a low density. The result is that the planarization process erodes the edges of the light modulator more than the center. This creates difficulty in producing a high quality of liquid crystal alignment

as well as variations in the thickness of the liquid crystal layer. The affect of these issues on the final 3D image was most severe when using incoherent, wide bandwidth, wide angle arc lamp illumination. Use of narrow band, collimated laser illumination dramatically improved the light modulator contrast ratio allowing the prototype display to function at a reasonable, but still sub-commercial, level.

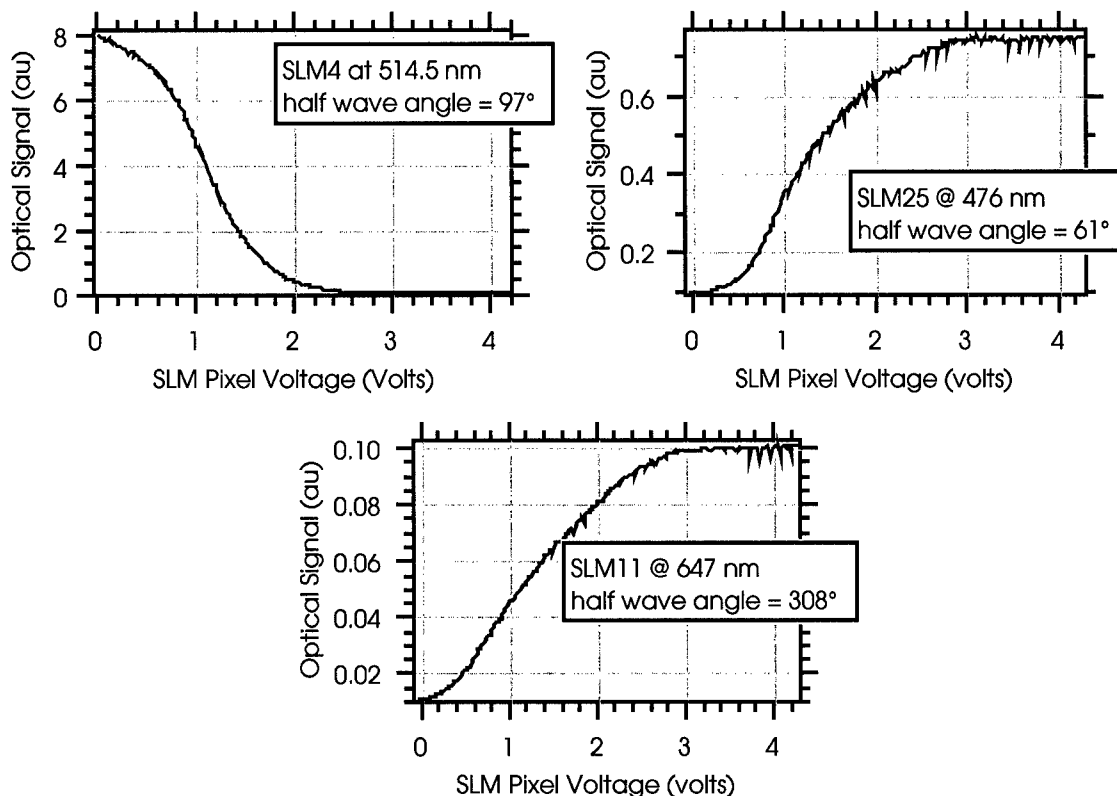

Figure 6. Graphs of the optical signal versus SLM pixel voltage for the red, green and blue SLMs. The graphs clearly show the grayscale behavior of the SLMs. The vertical scale is arbitrary.

The process for eliminating the light modulator defects is straightforward but expensive. It involves iterative modifications to the CMOS design followed by fabrication and testing of the resultant design. These modification entail the arrangement of dummy structures in the SLM periphery to obtain uniform planarization. Additional CMOS processing steps are also necessary to eliminate any height discontinuities between the pixel electrodes and inter-electrode spaces that can also affect alignment uniformity. Each iteration of this process can cost between \$50,000 and \$100,000 and take 3 months. Given this great cost, DMA has determined that near-term future MVD systems will be built using light modulators whose uniformity is well developed. Top among these is the DLP technology from Texas Instruments which will provide the light modulation technology for the next generation MVD.

D. TASK 1 - MOE Improvements

The MOE for this project was greatly improved in terms of its size and material speed over the previous generation. The previous MOE used shutter cells from

Crystaloid, Inc. (Kent, OH) that are 6" x 6" whereas the new MOE uses shutter cells that are 15.1" x 13.5" from LXD, Inc. (Kent, OH). To utilize the new cells a considerable refinement of the liquid crystal vacuum filling equipment and technique was required. A much larger vacuum chamber was designed and built to accommodate the larger cells. Additionally, a vacuum manipulation system designed to fill five cells simultaneously was designed and built. Mechanical drawings of the chamber and cell manipulator is shown in Appendix F. A hydraulic cell press for squeezing the filled cells down to a uniform thickness was constructed by adding large ground steel press platens to a standard 10 ton hydraulic press (Dake Dura-Press Model Force 10). The platens are larger than the MOE cells and allow the press to uniformly compress the cells to their design thickness (14 microns). Mechanical drawings of the cell press are included in Appendix G.

The filling technique refinements included careful control of the minimum vacuum pressure, careful control of pressure ramping profile, and electrical preconditioning of cells to eliminate shorts. Special LC material handling techniques were also developed to guarantee mixture performance after being filled into cells.

Also developed for this project was a custom MOE driver. The schematics are included in Appendix H. The driver was designed to be as general purpose as possible given the early uncertainties about the voltage, timing, and MOE cell number. Accordingly the driver is designed to drive up to 50 MOE cells, at voltages ranging from 20 volts to 300 volts and with pulse widths from 0.1 milliseconds up to 9.99 milliseconds. The MOE driver is designed to drive the MOE cells with a bipolar electrical waveform like that shown in figure 7. A cell is powered into the clear state by applying a field greater than 10 volts/micron. To become scattering the voltage is rapidly brought to 0 volts. The voltage is held at 0 volts for a period of roughly 2 milliseconds (zero period duration) before being brought back to the clear state by applying a voltage of the opposite polarity as before. The use of a bipolar waveform causes the applied field to average out to zero thereby avoiding potential shutter degradation known to be associated with DC applied fields.

Figure 8 shows the transmission versus time for a typical MOE cell at a number of different zero period durations. The cell exhibits an ~1 msec period after the field is removed during which it remains highly transparent. Then the cell switches quickly and cleanly to a low transmission state in approximately 500 microseconds. The transmission remains low until the field is reapplied, after which it makes an immediate jump back to high transmission. The off-to-on switching time depends on the width of the zero period but is approximately 50 microseconds in the range of zero periods appropriate to MVD operation (FWHM ~2 msec).

To develop the LC materials for this project we subcontracted with Dr. Deng-Ke Yang of the Liquid Crystal Institute (LCI) of Kent State University. Dr. Yang performed the original published research (ref. 5) that led to the material used in the previous MVD generation and so was deemed to be the best person to help develop new materials for the MVD.

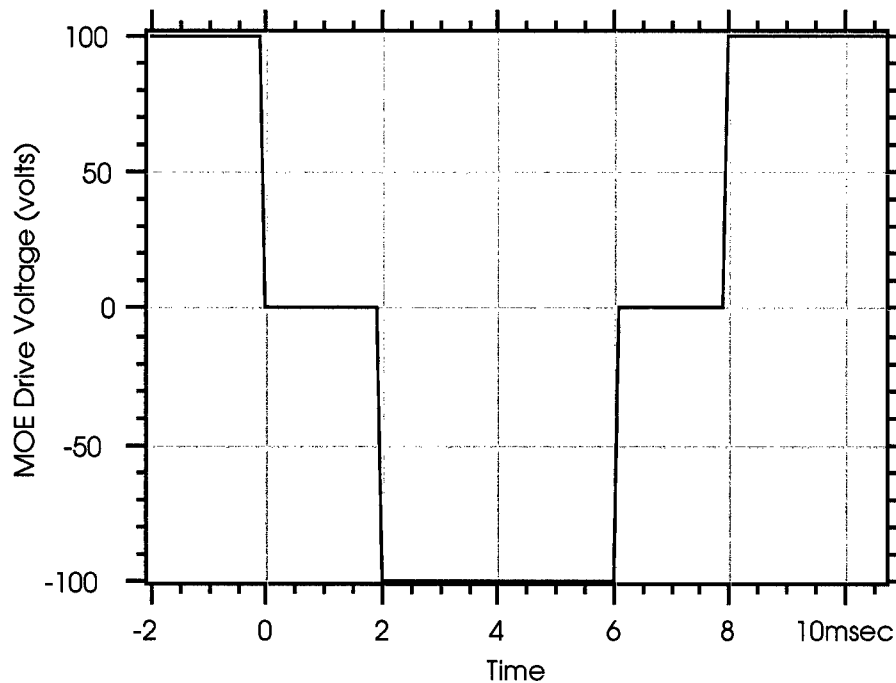

Figure 7. Bipolar drive waveform applied to MOE cells by the MOE driver. A bipolar waveform has an average field of 0 volts to avoid cell degradation caused by DC fields.

These liquid crystal materials are of a class known as polymer stabilized cholesteric textures (PSCT) in which a small percentage (~2.5% by weight) of a liquid crystal polymer is added in its unpolymersed, monomer state to a chiral nematic liquid crystal. The pitch length of the chiral nematic is chosen to be in the infrared making its interaction with visible light weak. By filling the liquid crystal/monomer mixture into the cell, aligning the liquid crystal with an applied electric field and then polymerizing the monomer, the cell become highly scattering when the field is remove. Dr. Yang spent a number of months trying a range of different nematic liquid crystals, chiral additives, and liquid crystal polymers before identifying a mixture that provides the desired electro-optic characteristics. This mixture is by no means optimized but is adequate for this generation of MVD. Future MOE work will focus on material optimization as well as engineering the multi-layer coatings within the MOE cell to minimize losses due to reflections.

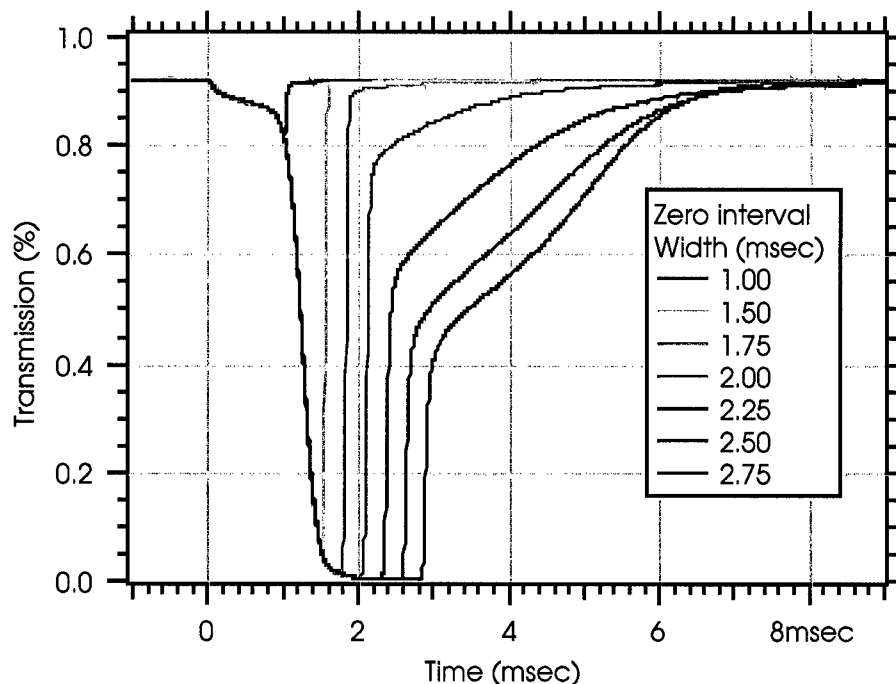

Figure 8. Transmission versus time at a number of different zero period durations for a typical MOE cell. Transmission losses are dominated by approximately 8% reflection between air-glass interfaces.

E. TASK 5b – MVD Integration

The integration of the Multiplanar Volumetric Display developed under this program took place over approximately six months. The greatest challenges of the integration process was that of carefully characterizing the pixel voltage to optical output transfer functions shown in figure 6. Each SLM must be tested separately using a linear look-up-table in the DAC section of the framebuffer. The resulting data is then inverted, scaled and loaded into the LUT to linearize the output of the SLM. Additional integration steps included careful color convergence and color balancing to achieve a reasonable white point.

Figure 9. shows a photograph of the entire integrated MVD system. Indicated in the photo are the computer, framebuffer, lasers, high speed video projector, MOE driver and both a small and large MOE. The small MOE, developed under a previous non-government program uses 12 planes, each 6" x 6" and is used for full color images since the available laser power is insufficient for full color images in the large MOE. Figure 10 shows a close-up photograph of the completed high speed video projector. Indicated are the lasers, framebuffer, light modulators, x-cube color combiner and projection lens.

Figures 11, 12, and 13 show photographs of 3D images in the small MOE. Figure 11 is a solid 3D skull while figure 12 is the same image in wireframe. Figure 13 is a brightly color 3D knot drawn by DMA to showcase the full color, grayscale capability of the display. The graininess in these images is caused by the coherent nature of the laser light. Use of arc lamp illumination in future systems will eliminate this effect.

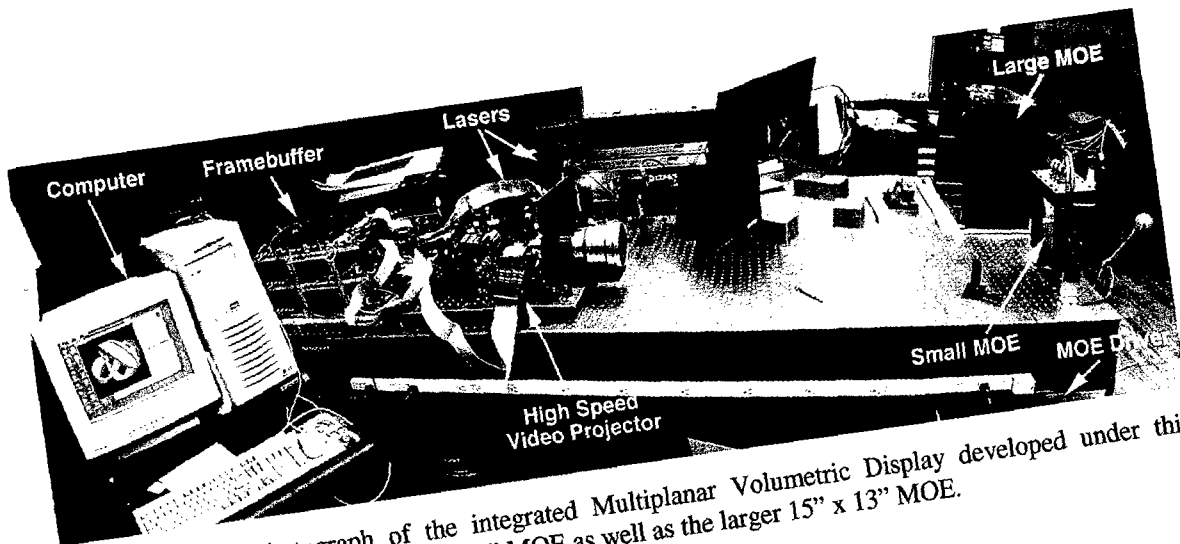

Figure 9. Photograph of the integrated Multiplanar Volumetric Display developed under this program. On the right are a small 6" x 6" MOE as well as the larger 15" x 13" MOE.

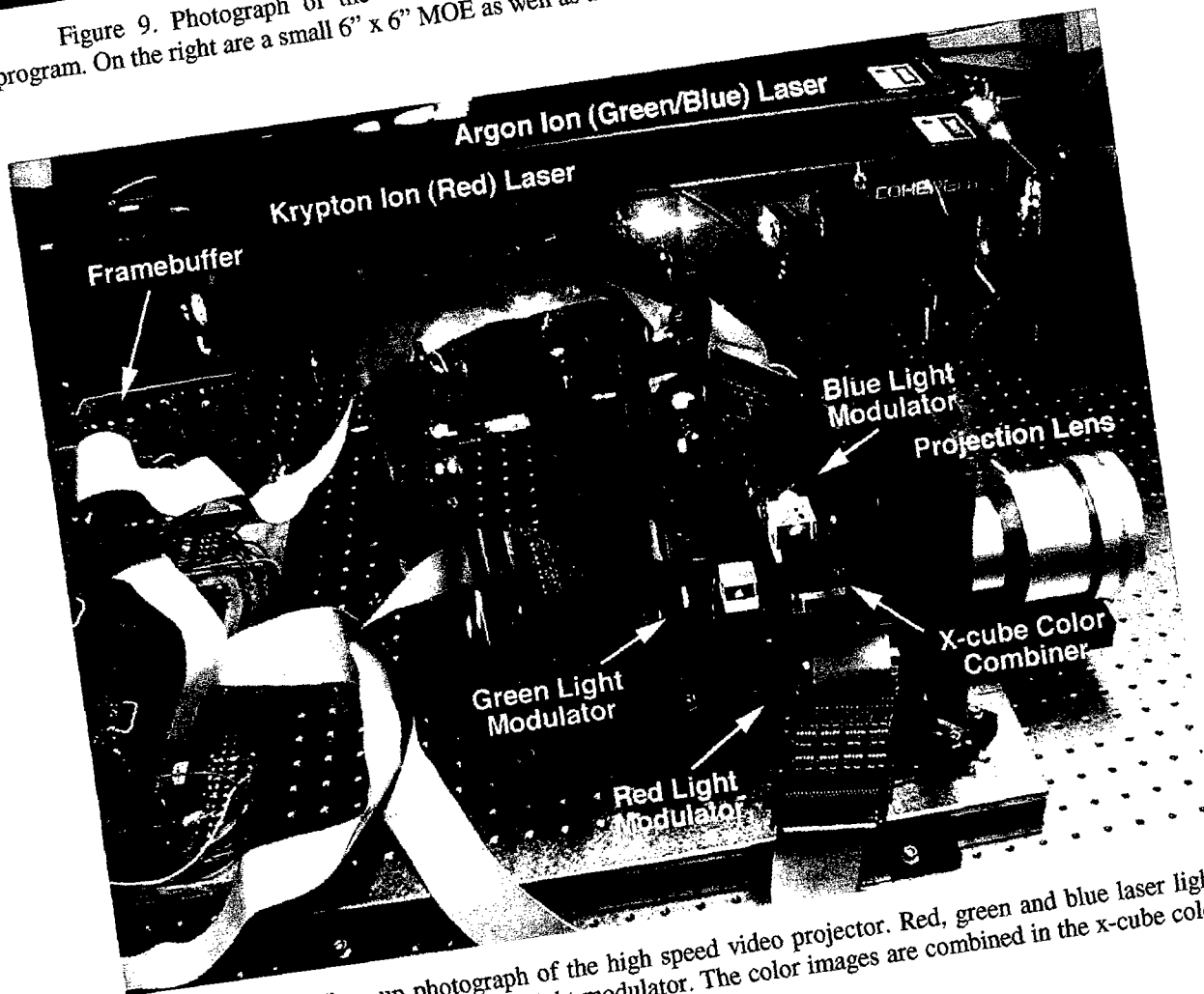

Figure 10. Close-up photograph of the high speed video projector. Red, green and blue laser light enters from above and illuminates the light modulator. The color images are combined in the x-cube color combiner and projected by the projection lens into the MOE.

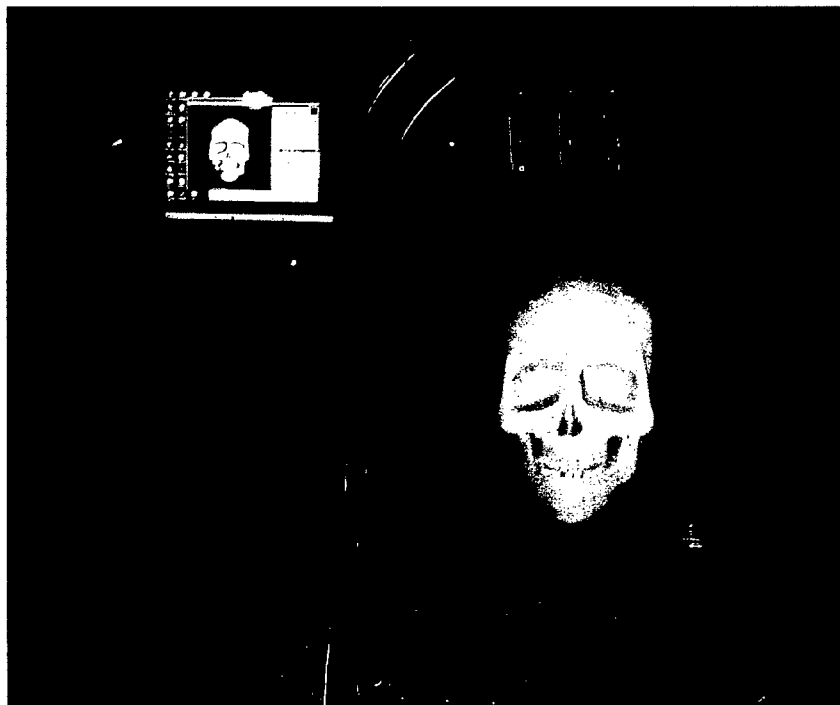

Figure 11. Close-up photograph of the operating MVD. In the background to the left is the computer screen showing the conventional 2D image, while to the right is the full color 3D image in the small MOE. Limited power from the lasers prevents production of a full color image in the large MOE.

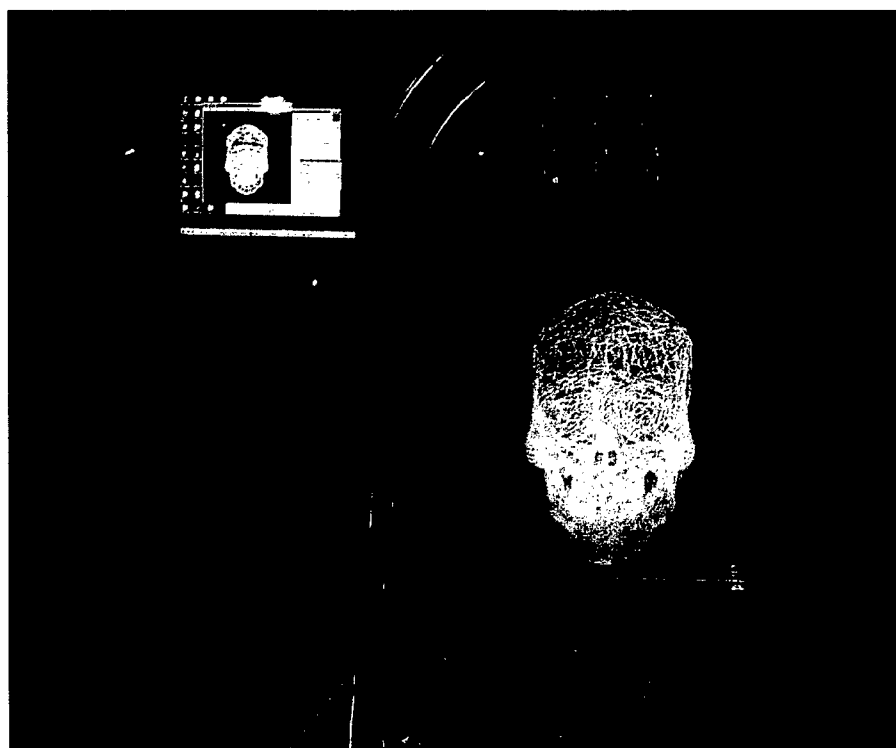

Figure 12. Close-up photograph of the operating MVD. The image is a 3D wireframe version of the same image as in figure 11.



Figure 13. Close-up photograph of the operating MVD. The image is a full-color geometric knot developed to exhibit the full color performance of the display.

F. TASK 2 - Volumetric Floating Image Projector

The extensive and unexpected extra effort and expense necessary to develop the custom aFLCoS light modulator resulted in the decision not to pursue the development of real image projection optics for the floating images projector. Given the straight forward nature of this element of the project there is little risk or challenge in developing the optics at a later date.

III. KEY RESEARCH ACCOMPLISHMENTS

- Development of both SGI and PC interfaces to the Multiplanar Volumetric Display
- Development of the MVD software Application Programming Interface (API)
- Identification and adoption of a high speed data transfer interface technology
- Development of a custom MVD framebuffer incorporating Multiplanar Anti-aliasing
- Customization of analog ferroelectric liquid crystal on silicon (aFLCoS) spatial light modulators for use in a high speed video projector
- Development of a projection engine architecture to convert the spatial light modulator into a video projector

- Development of improved MOE materials
- Development of large MOE cells and the tools and methods to fill them correctly
- Development of a MOE driver

IV. REPORTABLE OUTCOMES

The most significant outcome of the project was the dramatic advancement of the MVD technology toward a commercial performance level. Although the prototype MVD described herein is not adequate for commercialization, it has played a crucial role in helping to identify the final improvement necessary to achieve it. In fact, the majority of the subsystems of the display performed in ways that can be used commercially. Only the light modulator needs to be refined. This refinement is taking place as of this writing. Texas Instruments has greatly reduced the level of restrictions on novel uses of their DLP technology allowing DMA to develop a version of the MVD using DLP. Given to excellent performance of every other subsystem of the display, it is expected that the next generation prototype will exhibit all of the performance characteristics necessary for commercialization. Following this step the Advanced Volumetric Surgical Simulator can be developed.

V. CONCLUSIONS

The result of this project was a significant advancement of the Multiplanar Volumetric Display technology toward a commercial performance level. Nearly all of the improvements in the technology undertaken during this project were successful. The one area still in need of improvement is the spatial light modulator of the high speed video projector. The solution to that issue is being pursued currently with the expectation that by the third quarter of 2001 an MVD system of commercial performance will be operational.

Future work also includes continuing to extend the addressing modes of the MVD framebuffer to increase the image update rate toward realtime, development of the graphics processor by a third party that supports the MVD directly, continued improvements to the MOE materials and cells, and the extension of the API to incorporate tactile interaction.

From a fundamental scientific standpoint the commercial MVD systems resulting from this project will enable the visualization of 3D information in a way never before possible. From medicine to science to industry the MVD will have a sweeping impact that will accelerate our comprehension of all forms of information and enable new breakthroughs over a tremendous breadth of industries.

VI. REFERENCES

1. J. Bowren, T. Schmidt, "A New High Resolution Liquid Crystal Light Valve Projector", *SPIE Conference on Projection Displays IV*, **3296**, 105 (1998).
2. D. J. McKnight, K. M. Johnson, R. A. Serati, "256 x 256 Liquid-crystal-on-silicon spatial light modulator", *Applied Optics*, **33**, 2775 (1994).
3. M. Bone, "Optical-System Designs for LCoS Front Projectors", *Information Display*, **17**, 10 (2001).
4. I. Underwood; "VLSI design and fabrication for liquid crystal on silicon", *IEE Colloquium on "Microdisplay and smart pixel technologies"*, IEE Colloquium Digest **00/006**, 7/1-7/6 (2000).
5. D. K. Yang, L. C. Chien, J. W. Doane, "Cholesteric liquid crystal/polymer dispersion for haze-free light shutters", *Applied Physics Letters*, **60**, 3102 (1992).

VII. APPENDICES

A. MVD API Source Code

The following pages contain the source code of version 1.0 of the MVD API written in Borland Delphi 5.0.

unit MOEUnit;

interface

uses Forms, Windows, Dialogs, SysUtils, Math, OpenGL12, NiDAQUnit;

{ special types }

type

MVD32=longword; //unsigned 32 bit

PWord = ^Word;

PLongword = ^LongWord;

PByte = ^Byte;

TMVDrec = record

 ProcessBool,

 WriteBool,

 BlockFlag:boolean; //Whether Plane or block mode, plane assumed if not block

 GammaBool,

 BackDropBool,

 AutoScaleBool:boolean; //Auto Depth Scale enabled

 MVD_near, MVD_far: double; //Used if not auto scaling (world space coordinates)

 MVD_NumPlanes:word;

 MVD_SizeW, MVD_SizeH: word;

 MVD_clip_near, MVD_clip_far: double; //Used if not auto scaling (z buffer space)

end;

const

 //READ FROM INI OR REGISTRY OR SOMEWHERE

 MOESize_W=longword(512);

 MOESize_H=longword(512);

 MOESizeSquared=longword(MOESize_W*MOESize_H);

 // define MVD state indices

 MVDState_NumPlanes = 1;

 MVDState_ProcessBool = 2;

 MVDState_WriteBool = 3;

 MVDState_GammaBool = 4;

 MVDState_BackDropBool = 5;

 MVDState_AutoScaleBool = 6;

 MVDState_MVD_near = 7;

 MVDState_MVD_far = 8;

 MVDState_MVD_SizeW = 9;

 MVDState_MVD_SizeH = 10;

 MVDState_Clip_near = 11;

 MVDState_Clip_far = 12;

 MVDState_Blockflag = 13;

 //define mvdError indices

 mvdError_state = 1;

 mvdError_memory = 2;

 mvdError_nidaq = 3;

VAR

 MVDRec:TMVDrec; //MAKE PRIVATE AFTER DEBUG

 //ULTIMATELY PROBABLY WANT TO INTEGRATE THESE TWO

 BlockTransferBuffer2: array of MVD32;

 PlaneTransferBuffer2: array of MVD32;

 MOESizeSquared2:longword; //2 because 2nd revision of this var

 rgbabuffer2: array of longword; //2 because 2nd revision of this var, NB open array, (perf hit?)

 zbuffer2: array of Word; //2 because 2nd revision of this var, NB open array, (perf hit?)

 pscale:single;

 ack2state:integer = 0;

```

, req2state:integer = 0;

KZScale:single;
MOEUnit_NumPlanes:word;

MOEUnit_NearZClip:single = 0.1;
MOEUnit_FarZClip:single = 200;

FP_KZScale:longword; //made global 2/1/01 to allow switchoff of depth scanning

GammaLUT:array[0..127] of byte;
Faster_GammaLUT:array[0..255] of byte;

maxZ:longword;
minZ:longword;

/// MVD FUNCTION PROTOTYPES
function mvdInit: integer;
procedure mvdClose;
procedure mvdSet_state(state_var, value:word); overload;
procedure mvdSet_state(state_var:word; value:boolean); overload;
procedure mvdSet_state(state_var:word; value:double); overload;
procedure mvdRead_state(state_var:word; var value: word); overload;
procedure mvdRead_state(state_var:word; var value: boolean); overload;
procedure mvdRead_state(state_var:word; var value: double); overload;
procedure mvdTransfer;
procedure FASTER_mvdFormat_data;
procedure mvdFormat_data;
procedure mvdClearPlaneBuffer;
procedure mvdReadGL(top, left: word); overload;
procedure mvdReadGL; overload;

implementation

////////////////////////////////////

PROCEDURE SET_ACK2(state:smallint);
BEGIN
  if (state<>0) and (state<>1) then messagedlg('ACK2 state must be 0 or 1',mterror,[mbok],0);
  nidaqcall(DIG_Out_Line(1,4,3,state));
END;

FUNCTION GET_REQ2:smallint;
var state:smallint;
    bailoutcount:integer;
BEGIN
  bailoutcount:=0;
  repeat
    nidaqcall(DIG_In_Line(1,4,3,@state));
    inc(bailoutcount);
  until (state=1) or (bailoutcount > 1001);
  if bailoutcount>1001 then messagedlg('GET_REQ2 Bailed out after 1001
iterations',mterror,[mbok],0);
  result:=state;
END;

FUNCTION GET_OFFSET_FROM_XYP(x,y,p:word):longword;
//var add,col,COLSIZE:longword;
begin
  (*
  add:=0;
  COLSIZE:=16*512*NumPlanes; //the number of pixels before we hit next column on same plane
  //allow for preceding cols to go back to plane 0
  add:=add+(p*16*512);
  //calculate column & allow for preceding columns...
  col:=x div 16;
  add:=add+(col*colsize);
  //allow for rows

```

```

add:=add+(y*16);
//allow for pixinrow
add:=add+(x mod 16);
//so...
result:=add;
//so...
*)

result:=(p shl 13)+(((x div 16) shl 13)*MOEUnit_NumPlanes)+(y shl 4)+(x mod 16);

//so if...
//x=0, y=0 p=0 result=(0 shl 13)+(((0 div 16) shl 13)*MOEUnit_NumPlanes)+(0 shl 4)+(0 mod
16)=0
//x=511, y=511 p=11 result=90112+3047424+8176+15=3145727
//512^2=262144*4=1048576
end;

//-----

////////////////////////////////////
// Clear the PlaneTransferBuffer (set all values to zero //
////////////////////////////////////
procedure mvdClearPlaneBuffer;
begin
  fillchar(PlaneTransferBuffer2, sizeof(PlaneTransferBuffer2), 0);
end;

//-----

//FIXME It would be better if the returned a boolean indicating a bailout condition or not. JTS
1/2001
Procedure WaitForEndOfTransfer (QtyToTransfer, BailoutCeiling:longword);
var BailoutCount:integer;
    ulRemaining:Longint;
begin
  BailoutCount:=0;
  ulRemaining:=QtyToTransfer;
  While (ulRemaining > 0) and (BailoutCount<BailoutCeiling) do
    begin
      nidaqcall(DIG_Block_Check(1, 1, @ulRemaining));
      inc(BailoutCount);
    end;
  if BailoutCount=BailoutCeiling then messagedlg('Bailed out waiting for end of transfer after
'+inttostr(BailoutCeiling)+'
iterations, '+#13#10' ('+inttostr(ulRemaining)+'/'+inttostr(QtyToTransfer)+'
remaining)'+#13#10+'ie '+inttostr(QtyToTransfer-ulRemaining)+' done', mtwarning, [mbok], 0);
end;

//-----

//-----

//-----

//-----
procedure Build_GammaLUT;
var i:integer;
begin
  for i:=0 to 127 do GammaLUT[i]:=round(127*power((i/127),3)); //quad function

  //do it twice to fill zone 128..255 which is where we'll be reading it.
  for i:=0 to 255 do Faster_GammaLUT[i]:=round(127*power(((i shr 1)/127),3));
  //mask off the upper bit here so we don't have to do it in the critical loop
  for i:=0 to 255 do Faster_GammaLUT[i]:=Faster_GammaLUT[i] and 127;

```

```

end;
//-----
{TMVDrec = record
ProcessBool,
WriteBool,
GammaBool,
BackDropBool,
AutoScaleBool:boolean;
MVD_near, MVD_far: double;
MVD_NumPlanes:word;
MVD_SizeW, MVD_SizeH: longword;
end;}

function mvdInit: integer;
var returnU32:u32;
    returnI16:i16;
begin
  {*** SET UP MVD STATE ***}
  {** Allocate RAM & Init Nidaq stuff **}

//FIXME: VALIDATE MVD_SizeW, MVD_SizeH, Numplanes etc, errmess if not
with MVDRec do
  begin
    if (MVD_SizeW=0) or (MVD_SizeH=0) or (MOESizeSquared=0) then
      begin
        result:=mvdError_state;
        exit;
      end;
    MOESizeSquared2:=MVD_SizeW*MVD_SizeH;

    SetLength(PlaneTransferBuffer2, MOESizeSquared);
    //messagedlg('PlaneTranferBuffer:
'+inttostr(Length(PlaneTransferBuffer2)),mterror,[mbok],0);
    if Length(PlaneTransferBuffer2)<> MOESizeSquared then
      begin
        result:=mvdError_memory;
        exit;
      end;

    SetLength(BlockTransferBuffer2, MVD_NumPlanes*MOESizeSquared);
    //messagedlg('BlockTransferBuffer2:
'+inttostr(Length(BlockTransferBuffer2)),mterror,[mbok],0);
    if Length(BlockTransferBuffer2)<> MVD_NumPlanes*MOESizeSquared then
      begin
        result:=mvdError_memory;
        exit;
      end;

    SetLength(rgbabuffer2, MOESizeSquared2);
    //messagedlg('rgbabuffer2: '+inttostr(Length(rgbabuffer2)),mterror,[mbok],0);
    if Length(rgbabuffer2)<> MOESizeSquared2 then
      begin
        result:=mvdError_memory;
        exit;
      end;

    SetLength(zbuffer2, MOESizeSquared2*sizeof(word));
    //messagedlg('zbuffer2: '+inttostr(Length(zbuffer2)),mterror,[mbok],0);
    if Length(zbuffer2)<> MOESizeSquared2*sizeof(word) then
      begin
        result:=mvdError_memory;
        exit;
      end;

    //FIXME: Good architecture here? hw dependance on NIDAQ?

```

```

    //get nidaq version
    returnU32:=0;
    nidaqcall(Get_NI_DAO_Version(@returnI16));
    NIDAQversion:=inttohex(returnU32 and $FFFF,3);
    //get nidaq device name
    returnI16:=23;
    returnI16:=0;
    nidaqcall(Init_DA_Brds(1,@returnI16));
    NIDAQdevicename:=device_name(returnI16);
    //get nidaq base address
    returnU32:=0;
    nidaqcall(Get_DAO_Device_Info(1, ND_BASE_ADDRESS,@returnU32));
    NIDAQbaseaddress:='0x'+inttohex(returnU32,8);

    //configure the groups
    nidaqcall(DIG_Grp_Config(1, 1, 4, 0, 1));
    //set up group of ports for burst handshaking, using the REQ, ACK, and PCLK signals.
    nidaqcall(DIG_Grp_Mode(1, 1, 3, 0, 0, 0));
    //reverse the clock
    nidaqcall(Set_DAO_Device_Info(1, ND_CLOCK_REVERSE_MODE_GR1, ND_OFF));
    //align the data

//nidaqcall(Align_DMA_Buffer(1,13,@BlockTransferBuffer[0],NumWordsToTransfer,NumWordsToTransfer,(
    result:=0;
    end; // with MVDRec
end;

//-----

{*** DEALLOCS RAM & UNCONFIGURES NIDAQ ***}
procedure mvdClose;
begin
    PlaneTransferBuffer2:=nil;
    BlockTransferBuffer2:=nil;
    rgbabuffer2:=nil;
    zbuffer2:=nil;

    //Clear the block operation.
    DIG_Block_Clear(1, 1);
    //Unconfigure group.
    nidaqcall(DIG_Grp_Config(1, 1, 0, 0, 0));
end;

//-----

procedure mvdTransfer;
var NumWordsToTransfer:longword; //number of 32 bit words to transfer
begin
    with MVDRec do
        begin
            if blockflag then
                begin
                    NumWordsToTransfer := MVD_NumPlanes*MOESizeSquared2;
                    // set PCLK2 to HI to set block transfer
                    nidaqcall(DIG_Out_Line(1,4,1,1));
                    //volume handshaking: read req2, if high then cycle ack2
                    if Get_REQ2<>0 then begin Set_ACK2(1); Set_ACK2(0); end;
                    //Start the pattern generation output of count "items".
                    nidaqcall(DIG_Block_Out(1, 1, @BlockTransferBuffer2[0], NumWordsToTransfer));
                end else
                begin
                    NumWordsToTransfer := MOESizeSquared2;
                    // set PCLK2 to LO to set z-buffer transfer
                    nidaqcall(DIG_Out_Line(1,4,1,0));
                    //volume handshaking: read req2, if high then cycle ack2
                    if Get_REQ2<>0 then begin Set_ACK2(1); Set_ACK2(0); end;
                    //Start the pattern generation output of count "items".
                    nidaqcall(DIG_Block_Out(1, 1, @PlaneTransferBuffer2[0], NumWordsToTransfer));
                end
            end
        end
    end

```

```
    end;  
    WaitForEndOfTransfer(NumWordsToTransfer,10001);  
end; //with MVDRec  
end;
```

```
//-----  
// MULTIPLE OVERLOADED VERSIONS OF mvdSet_state  
//-----  
//NB Error handling should be integrated across all overloaded variants  
//change these to bool returning functions
```

```
procedure mvdSet_state(state_var, value:word); overload;  
begin  
  with MVDRec do begin  
    case state_var of  
      // define MVD state indices  
      MVDState_NumPlanes:    MVD_NumPlanes := value;  
      MVDState_MVD_SizeW:    MVD_SizeW:= value;  
      MVDState_MVD_SizeH:    MVD_SizeH:= value;  
      else messagedlg('Problem with using MVD_set_state!!',mterror,[mbok],0);  
    end; // case  
  end; // with MVDRec  
end;
```

```
procedure mvdSet_state(state_var:word; value:boolean); overload;  
begin  
  with MVDRec do begin  
    case state_var of  
      // MVD state indices  
      MVDState_ProcessBool:  ProcessBool := value;  
      MVDState_WriteBool:    WriteBool := value;  
      MVDState_GammaBool:    GammaBool := value;  
      MVDState_BackDropBool: BackDropBool := value;  
      MVDState_AutoScaleBool: AutoScaleBool := value;  
      MVDState_Blockflag:    BlockFlag := value;  
      else messagedlg('Problem with using MVD_set_state!!',mterror,[mbok],0);  
    end; //case  
  end; // with MVDRec  
end;
```

```
procedure mvdSet_state(state_var:word; value:double); overload;  
begin  
  with MVDRec do begin  
    case state_var of  
      // define MVD state indices  
      MVDState_MVD_near:    MVD_near:= value;  
      MVDState_MVD_far:    MVD_far:= value;  
      MVDState_Clip_near:  MVD_clip_near := value;  
      MVDState_Clip_far:   MVD_clip_far := value;  
      else messagedlg('Problem with using MVD_set_state!!',mterror,[mbok],0);  
    end; //case  
  end; // with MVDRec  
end;
```

```
//-----  
procedure mvdRead_state(state_var:word; var value: word); overload;  
begin  
  //messagedlg('MVDRead_state: word',mterror,[mbok],0);  
  with MVDRec do begin  
    case state_var of  
      // define MVD state indices  
      MVDState_NumPlanes:    value:=MVD_NumPlanes;  
      MVDState_MVD_SizeW:    value:=MVD_SizeW;  
      MVDState_MVD_SizeH:    value:=MVD_SizeH;  
      else messagedlg('Problem with using MVD_set_state!!',mterror,[mbok],0);  
    end; // case  
  end; // with MVDRec  
end;
```

```

procedure mvdRead_state(state_var:word; var value: boolean); overload;
begin
  //messagedlg('MVDRead_state: boolean',mterror,[mbok],0);
  with MVDRec do begin
    case state_var of
      // MVD state indices
      MVDState_ProcessBool:   value:=ProcessBool;
      MVDState_WriteBool:    value:=WriteBool;
      MVDState_GammaBool:    value:=GammaBool;
      MVDState_BackDropBool: value:=BackDropBool;
      MVDState_AutoScaleBool: value:=AutoScaleBool;
      MVDState_Blockflag:    value:=BlockFlag;
    else messagedlg('Problem with using MVD_set_state!!',mterror,[mbok],0);
    end; //case
  end; // with MVDRec
end;

```

```

procedure mvdRead_state(state_var:word; var value: double); overload;
begin
  with MVDRec do begin
    case state_var of
      // define MVD state indices
      MVDState_MVD_near:      value:=MVD_near;
      MVDState_MVD_far:      value:=MVD_far;
      MVDState_Clip_near:    value:=MVD_clip_near;
      MVDState_Clip_far:     value:=MVD_clip_far;
    else messagedlg('Problem with using MVD_set_state!!',mterror,[mbok],0);
    end; //case
  end; // with MVDRec
end;

```

//-----

```

{
NEED TO SPEED UP THE GAMMA LUT,
NEED TO SPEED UP THE RGLW SPLIT
NEED TO SPEED UP THE JJ CALCULATION
}

```

```

procedure mvdFormat_data;
var //PROCESS PIXEL STUFF: LOCAL VARIABLES SEEM TO BE FASTER (CREATED IN CACHE?)
  Kzscale:Single;
  pzbuffer:PWord;
  prgbabuffer:PLongword;
  temp:^Char;
  i:longword;
  j:longword;
  z:word;
  lw:longword;
  jj:longword;
  rglbw:longword;
  r,g,b:byte;
begin
  //FIXME GHASTLY PATCHWORK STUFF HERE!
  KZscale:=1;//default
  FP_KZScale:=65536; //ie 1 in 16 bit fixed point
  minZ:=20;
  maxZ:=45;
  with MVDrec do
    begin
      if AutoScaleBool then
        begin
          //scan zbuffer, getting minz & maxz
          minZ:=65535;
          maxZ:=0;
          pzbuffer:=@zbuffer2[0];
          for i:=0 to MOESizeSquared2-1 do

```

```

begin
  z:=pzbuffer^;      //get z value [0..65535]
  if z<65535 then    //don't include 'infinite' Z values in max min
    begin
      if z>maxZ then maxZ:=z else if z<minZ then minZ:=z;
      end;
      inc(pzbuffer);
    end;
end; { else
begin
  //assume minZ & maxZ are the same as the gl near/far clip planes
//
minZ:=round((MOEUnit_FarZClip/(MOEUnit_FarZClip-MOEUnit_NearZClip))*(1-(MOEUnit_NearZClip/MVD_n
//
maxZ:=round((MOEUnit_FarZClip/(MOEUnit_FarZClip-MOEUnit_NearZClip))*(1-(MOEUnit_NearZClip/MVD_f
  minZ:=round(MVD_clip_near*65536);
  maxZ:=round(MVD_clip_far*65536);
end; }
//compute scaling factor
if MaxZ<>MinZ then KZscale:=(MVD_NumPlanes-1)/(MaxZ-MinZ);
FP_KZScale:=round(KZscale*65536); //convert to 16 bit fixed point format
//*** PROCESS THE DATA ****
if ProcessBool then
begin
  //BUILD MVD32s
  prgbabuffer:=@rgbabuffer2[0];
  pzbuffer:=@zbuffer2[0];
  for j:=0 to (MOESizeSquared2-1) do //for each pixel...
    begin
      //GET P & D
      z:=pzbuffer^;      //get z value [minZ..maxZ]
      if BackDropBool then
        begin
          if z>maxz then z := maxz;
          end;
          z:=z-minZ;      //z [0...maxZ-minZ]
          LW:=z*FP_KZSCALE;
          LW:=LW+65536; //FUDGE TO FIX PLANES, adds on extra plane
//
          //SPLIT COLOR
          rglw:=prgbabuffer^; //ABGR
          r:= rglw and $FF;
          g:=(rglw shr 8) and $FF;
          b:=(rglw shr 16);
          //GAMMA CORRECT
          if GammaBool then
            begin
              r:=GammaLUT[r shr 1] shl 1;
              g:=GammaLUT[g shr 1] shl 1;
              b:=GammaLUT[b shr 1] shl 1;
            end;
          //BUILD MVD32 STRUCTURE
          asm
            PUSH EBX
            //CALCULATE d & p
            mov  ebx,LW          //EBX=..... ..pppppp ..... dddd
            mov  eax,ebx        //EAX=pppppppp pppppppp dddddddd dddddddd
            shr  eax,16         //EAX=..... ..ppppppp pppppppp
            mov  cl,al          //CL=P
            shr  bx,11          //EBX=pppppppp pppppppp ..... dddd
            //BUILD MVD32 from d,p,rgba
            shl  bx,4           // bx= .....d dddd....
            mov  ah,bh          //EAX=..... ..d .....
            xor  bh,bh          // bx= ..... dddd....
            shl  bx,1           // bx= .....d ddd....
            mov  al,bh          //EAX=..... ..d .....d
            shl  eax,16         //EAX=.....d .....d .....
            xor  bh,bh          // bx= ..... ddd....
            shl  bx,1           // bx= .....d dd....

```

```

mov ax,bx //EAX=.....d .....d .....d dd.....
or al,cl //EAX=.....d .....d .....d ddpppppp
mov ebx,eax //EBX=.....d .....d .....d ddpppppp

```

```

mov ah,r
mov al,g
shl eax,16
mov ah,b
mov al,0

```

```

and eax,$FEFEFE00 //EAX=rrrrrrrr. ggggggg. bbbbbbb. ....
or eax,ebx //EAX=rrrrrrrrd gggggggd bbbbbbbd ddpppppp
//STORE RESULT
mov rglw,eax
POP EBX

```

```

end;
//CALCULATE PLANE BUFFER INDEX
{ jj:=((j div 16) mod 32) shl 13)+
((j div MVD_SizeW) shl 4)+
(j mod 16)-1; //jj:=(col*8192)+(row*16)+pix; pp_pix-1 = FUDGE TO REMOVE

```

ROGUE VERTICAL LINES}

```

//CALCULATE PLANE TRANSFER BUFFER OFFSET

```

asm

```

PUSH EBX
mov eax,J
shr eax,4
and eax,31
shl eax,13
mov ebx,J
shr ebx,9
shl ebx,4
add eax,ebx
mov ebx,J
and ebx,15
add eax,ebx
dec eax
mov JJ,eax
POP EBX

```

```

end;
PlaneTransferBuffer2 [jj]:=rglw;
inc (prgbabuffer);
inc (pzbuffer);

```

```

end;//next j
end;//processbool

```

```

//*** WRITE THE DATA ***
// if WriteBool then SendPlaneTransferBuffer;
//mvdTransfer;

```

end;

end;

procedure FASTER_mvdFormat_data;

var //PROCESS PIXEL STUFF: LOCAL VARIABLES SEEM TO BE FASTER (CREATED IN CACHE?)

Kzscale:single;

pzbuffer:PWord;

prgbabuffer:PLongword;

temp:^Char;

i:longword;

j:longword;

z:word;

lw:longword;

jj:longword;

rglw:longword;

r,g,b:byte;

p:^byte;

begin

```

//FIXME GHASTLY PATCHWORK STUFF HERE!
KZscale:=1;//default
FP_KZScale:=65536; //ie 1 in 16 bit fixed point
with MVDrec do
  begin
    if AutoScaleBool then
      begin
        //scan zbuffer, getting minz & maxz
        minZ:=65535;
        maxZ:=0;
        pzbuffer:=@zbuffer2[0];
        //_____ CRITICAL LOOP _____
        for i:=0 to MOESizeSquared2-1 do
          begin
            z:=pzbuffer^; //get z value [0..65535]
            if z<65535 then //don't include 'infinite' Z values in max min
              begin
                if z>maxZ then maxZ:=z else if z<minZ then minZ:=z;
              end;
            inc(pzbuffer);
          end;
        //AutoScaleBool:=false;
        //_____ END CRITICAL LOOP _____
      end; { else
      begin
        //assume minZ & maxZ are the same as the gl near/far clip planes
//
minZ:=round((MOEUnit_FarZClip/(MOEUnit_FarZClip-MOEUnit_NearZClip))*(1-(MOEUnit_NearZClip/MVD_n
//
maxZ:=round((MOEUnit_FarZClip/(MOEUnit_FarZClip-MOEUnit_NearZClip))*(1-(MOEUnit_NearZClip/MVD_fa
minZ:=round(MVD_clip_near*65536);
maxZ:=round(MVD_clip_far*65536);
end; }

//compute scaling factor
if MaxZ<>MinZ then KZscale:=(MVD_NumPlanes-1)/(MaxZ-MinZ);
FP_KZScale:=round(KZscale*65536); //convert to 16 bit fixed point format
//*** PROCESS THE DATA ****
if ProcessBool then
  begin
    //BUILD MVD32s
    prgbabuffer:=@rgbabuffer2[0];
    pzbuffer:=@zbuffer2[0];
//_____ CRITICAL LOOP _____
    for j:=0 to (MOESizeSquared2-1) do //for each pixel...
      begin
        //GET P & D
        z:=pzbuffer^; //get z value [minZ..maxZ]
//if BackDropBool then if z>maxz then z := maxz; MOVE THIS OUTSIDE!
        z:=z-minZ; //z [0...maxZ-minZ]
        LW:=z*FP_KZSCALE;

        rglbw:=prgbabuffer^; //ABGR

        //GAMMA CORRECT EACH COMPONENT
        asm
          //SPLIT RGLBW TO RGB
          mov eax,rgblw //ABGR
          mov R,al
          mov G,ah
          shr eax,8
          mov B,ah
        end;
        r:=Faster_GammaLUT[r];
        g:=Faster_GammaLUT[g];
        b:=Faster_GammaLUT[b];
        asm
          //REASSEMBLE RGLBW
          mov dh,R //EDX=..... .rrrrrrr .....

```

```

mov dl,G //EDX=..... .rrrrrrr .ggggggg
shl edx,16 //EDX=.rrrrrrr .ggggggg .....
mov dh,B //EDX=.rrrrrrr .ggggggg .bbbbbbb .....
shl edx,1 //EDX=rrrrrrr. ggggggg. bbbbbbb. ....
//BUILD MVD32 STRUCTURE
PUSH EBX
//*****
/* THIS NEXT BIT (TO THE POP) IS SUB OPTIMAL DUE TO PARTIAL PROCESSOR STALLS *
/* CAUSED PRIMARILY BY MIXING 8 & 32 BIT OPERANDS - SEE GAMASUTRA *
//*****
//ISOLATE P FROM LW
mov ebx,LW //EBX=..... .pppppp DDDDDddd .....
shr ebx,8 //EBX=..... .pppppp DDDDDddd .....
mov cl,bh //CL=P at this point
//SPLIT UP D APPROPRIATELY
xor bh,bh //EBX=..... DDDDDddd .....
shl bx,1 //EBX=..... D DDDddd.
mov bh,ah //EAX=..... D .....
xor bh,bh //EBX=..... DDDDDddd.
shl bx,1 //EBX=..... D DDDddd..
mov bh,al //EAX=..... D .....
shl eax,16 //EAX=.....D .....
xor bh,bh //EBX=..... DDDddd..
shl bx,1 //EBX=..... D DDddd...
and bx,192 //EBX=..... D DD.....
mov ax,bx //EAX=.....D .....
//BUILD MVD32 from d,p,rgba
or al,cl //EAX=.....d .....d .....d ddpppppp
or eax,edx //EAX=rrrrrrrd gggggggd bbbbbbbd ddpppppp
//STORE MVD32 RESULT
mov RGLW,eax
//CALCULATE PLANE TRANSFER BUFFER OFFSET
mov eax,J
shr eax,4
and eax,31
shl eax,13
mov ebx,J
shr ebx,9
shl ebx,4
add eax,ebx
mov ebx,J
and ebx,15
add eax,ebx
dec eax
mov JJ,eax
POP EBX
end;
PlaneTransferBuffer2 [jj]:=rgblw;
inc (prgbabuffer);
inc (pzbuffer);
end;//next j
end;//processbool
end;
end;

```

```

//-----
procedure mvdReadGL; overload;
begin
  with mvdrec do
  begin
    ghreadpixels(0, 0, MVD_SizeW, MVD_SizeH,
                 GL_RGBA, GL_UNSIGNED_BYTE,
                 @rgbabuffer2[0]);

```

```

    glReadPixels(0, 0, MVD_SizeW, MVD_SizeH, GL_DEPTH_COMPONENT, GL_UNSIGNED_SHORT,
    @zbuffer2[0]);
end;
end;

procedure mvdReadGL(top, left:word); overload;
begin
    with mvdrec do
    begin
        glreadpixels(top, left, MVD_SizeW, MVD_SizeH,
        GL_RGBA, GL_UNSIGNED_BYTE,
        @rgbabuffer2[0]);
        glReadPixels(top, left, MVD_SizeW, MVD_SizeH, GL_DEPTH_COMPONENT, GL_UNSIGNED_SHORT,
        @zbuffer2[0]);
    end;
end;

```

```

//SELF INITIALIZING CODE
begin
    MOEUnit_NumPlanes:=12; //SHOULD BE READ FROM INI OR SOMEWHERE
    //MOEUnit_NumPlanes:=MVD_NumPlanes;
    Build_GammaLUT;
end.

```

```

(*)

DATA TRANSFER MODES
=====
1) BLOCK MODE
The entire 50 plane data set is sent at 32 bits per pixel:
[R7x G7x B7x x8].
AA is done by host computer if desired.
NB 11 bits are {redundant/not used/reserved for future development}.

```

```

2) PLANE (Z BUFFER) MODE
A single page of 512*512 pixels is sent, along with D & P as a 32 bit word:
[R7D G7D B7D D2P6]
The MOE uses P to place RGB in the correct address and uses D to modulate.

```

```

DISPLAY RAM
=====
The display RAM in the MOE3 is laid out as follows:

```

```

There are 50 planes:
Each plane is 512*512 pixels
Each plane is arranged as 32 columns, each 16 pixels wide and 512 rows deep
Memory locations are sequential as follows:

```

```

for column:=1 to 32 do
begin
    for plane:=1 to 50 do
    begin
        for row:=1 to 512 do
        begin
            for pixel:=1 to 16 do
            begin
                begin
                end;
            end;
        end;
    end;
end;
end;

```

This equates to $(32*16)*512*50 = 13,107,200$ pixels

Each pixel is 32 bit and contains the following data:

```

rrrrrrrd gggggggd bbbbbbd dppppppp

```

The entire structure is therefore:

13107200*4= 52,428,800 bytes,

52428800/1024= 51,200 kB

51200/1024= 50 Mb

This needs to be dumped to the MOE at 30fps, a transfer rate of 1500MB/sec or 1.46GB/sec

So the MOE driver program needs to:

a) Read the Color Buffer

b) Read the Depth Buffer

PAGE MODE:

c) Compute Plane and Delta data for each pixel

d) Reformat the data into the 512*512*[DR7 DG7 DB7 D2P6] array structure

e) Dump the 512*512*32bit structure to the MOE via PCI bus

BLOCK MODE:

c) Compute Plane and Delta data for each pixel

d) Populate the entire 512*512*50*[xR7xG7xB7] structure based on RGB & Plane

d) Modulate RGB on a per pixel basis based on the delta

e) Dump the 512*512*50*24bit structure to the MOE via PCI bus

a) Read the Color Buffer

This is done using `glReadPixels`, a non hw accelerated function (unless using certain models of Intergraph PCs). Ultimately we want to express each color as a 7 bit number, so ideally we'd like `glReadPixels` to return a byte between 0 & 127. Happily OpenGL does this for us if we specify a format of `GL_BYTE` in the `glReadPixels` command.

`glReadPixels(0,0,512,512,GL_BYTE,GL_RGB,@pixels)` will give us a 512*512 array of RGB triplet bytes. The total size of the array will be 512*512*3=786,432 bytes=768kB or 0.75MB and we can rely on the msb in each byte being = 0.

RGBpixels:array[0..786432] of byte;

value: 0rrrrrrrr 0ggggggg 0bbbbbbb 0rrrrrrrr 0gggggggg 0bbbbbbb

pixel: 0----- 1-----

byte: 0----- 1----- 2----- 3----- 4----- 5-----

b) Read the Depth Buffer

This is also done using `glReadPixels`. Ultimately we want to express the depth as a 5 bit number representing the plane [0..50], and a 5 bit number representing the delta. At the moment (MOE2) we read this as a 4 byte [0..1] `GLfloat` because we need the fractional part to calculate the delta.

This is quite slow because we're reading 512*512*4=1048576= 1MB.

It also provides us with more data than we can use, since we only have 5 bit delta. Because we have only 32 delta values we only need fractional accuracy to 1/32=0.03125.

The usable range for us is therefore 50*32=1600. 1600 is 11001000000 in binary, ie our usable range will fit into 11 bits, so reading a 16 bit value will be more than adequate for our needs.

`glReadPixels(0,0,512,512,GL_SIGNED_SHORT,GL_DEPTH_COMPONENT,@depthpixels)` will give us a 512*512*2 array of words. The total size of the array will be 512*512*2=524,288 bytes=512kB or 0.5MB.

Although this in theory should execute twice as fast as a float read, we have some post processing to do. Since we're reading signed shorts the range is 0..32768 and we can rely on the msb=0.

The range of each depthpixel is [0..32767]. From this integer we have to derive a float number in the range [0..49]. `pscale=49/32767=0.0014954069643`.

So we could multiply each depth pixel by this number.

This is an awkward number to try to optimize, but at least its a constant...

c) Compute Plane and Delta data for each pixel

```
-----
plane=depthpixel*pscale;
delta=frac(plane)
plane=round(plane)
```

so..

```
MOE2 float read....
depthpixel=0.555
plane:=50*depth=27.75
delta:=frac(plane)=0.75
plane:=round(plane)=27
```

```
MOE3 word read....
depthpixel=0.555*32768=18186
plane=18186*pscale=27.749633789
delta=frac(27.749633789)=0.749633789
plane=round(27.749633789)=27
```

so the error is $27.75 - 27.749633789 = 0.000366211$, not worth worrying about.

In order to pack the delta into 5 bits for the output 32 bit word we take
delta:=round(delta*31)??

d) Reformat the data into the new array structure

```
rgbpixels    depthpixels
|            |         |
|            plane    delta
|            |         |
|            |         |
=====MOE=====
```

```
TRGBtriplet=array[0..2] of byte;
RGBpixels=array[0..262144] of TRGBtriplet;
depthpixels=array[0..262144] of integer;
MOE=array[0..31][0..49][0..511][0..15] of longword
```

```
pixelnum:=0;
for column:=1 to 32 do
  begin
    for plane:=1 to 50 do
      begin
        for row:=1 to 512 do
          begin
            for pixel:=1 to 16 do
              begin
                r:=RGBpixels[pixelnum][0];
                g:=RGBpixels[pixelnum][1];
                b:=RGBpixels[pixelnum][2];
                f:=DepthPixel[pixelnum]*pscale; // ugh, floating point
                p:=round(f); // ugh, floating point
                d:=round((f-p)*31); // ugh, floating point
                //BIT TWIDDLING STARTS HERE
                lw:=(r shl 1)+(d and 1); //lw=00000000 00000000 00000000 rrrrrrrd
                lw:=lw shl 8;
                lw:=lw+(g shl 1)+((d and 2) shr 1); //lw=00000000 00000000 rrrrrrrd gggggggd
                lw:=lw shl 8;
                lw:=lw+(b shl 1)+((d and 4) shr 2); //lw=00000000 rrrrrrrd gggggggd bbbbbbbd
                lw:=lw shl 8;
                lw:=lw+((d and 24) shl 3)+(p and 63); //lw=rrrrrrrd gggggggd bbbbbbbd dppppppp
                MOE[column][plane][row][pixel]:=lw;
                inc(pixelnum);
              end;
            end;
          end;
        end;
      end;
    end;
  end;
end;
```

Of course it would be nice to loop this in machine code...

The bit twiddling is straightforward, the multiplication by an fp constant should be an FMUL (precludes the use of SIMD - careful) and the input addressing all has the same offset. Calculating the output address might be a pain....

e) Dump the structure to the MOE via PCI bus
Just pass NIDAQ the address of the MOE struct and hit the go button.

*)

B. MVD322 Data Word Format

The data word assembled by the *mvdFormat_data* API function is known as an MVD32 type. It is a 32-bit data word with the following format:

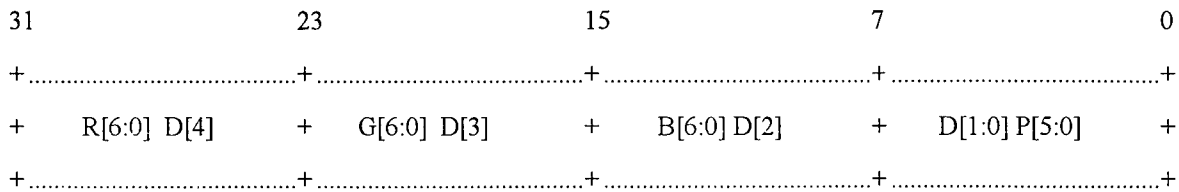

Where:

R[6:0] is the 7-bit red data,

G[6:0] is the 7-bit green data,

B[6:0] is the 7-bit blue data,

D[4:0] is the 5-bit fractional portion of the depth, and

P[5:0] is the 6-bit integer portion of the pixel depth

This data word format was developed to maximize the rate at which the API function *mvdFormat_data* runs. The format of the color data retrieved from the framebuffer by *mvdReadgl* is a 32-bit number with the red, green and blue data already in the correct locations within the MVD32 data word. The only operation required is to splice the pieces of the depth value into the data word.

C. Data Transfer Cable Pin Assignments

The following figure is scanned from the documentation of the National Instruments PCI-DIO-32HS high speed data transfer card. It is Figure 4-1 indicating the pin assignments of the 68-pin output connector. (July 1997 Edition)

GND	DIOD6	DIOD5	GND	DIOD2	DIOD1	GND	DIOC6	DIOC5	GND	DIOC2	DIOC1	RGND	GND	DIOB5	DIOB4	DIOB3	DIOB2	GND	GND	DIOA6	DIOA5	GND	DIOA2	DIOA1	RGND	GND	GND	CPULL	GND	DPULL	GND	GND	RGND																																		
34	68	33	67	32	66	31	65	30	64	29	63	28	62	27	61	26	60	25	59	24	58	23	57	22	56	21	55	20	54	19	53	18	52	17	51	16	50	15	49	14	48	13	47	12	46	11	45	10	44	9	43	8	42	7	41	6	40	5	39	4	38	3	37	2	36	1	35
DIOD7	GND	DIOD4	DIOD3	GND	DIOD0	DIOD7	GND	DIOC4	DIOC3	GND	DIOC0	DIOB7	DIOB6	GND	DIOB0	DIOD7	DIOA7	GND	DIOA4	DIOA3	GND	DIOA0	REQ2*	ACK2 (STARTTRIG2)*	STOPTRIG2	PCLK2	PCLK1	STOPTRIG1	ACK1 (STARTTRIG1)*	REQ1*	+5 V																																				

Pins DIOD[7:1] correspond to R[6:0] in the MVD32 data word

Pin DIOD[0] correspond to D[4] in the MVD32 data word

Pins DIOC[7:1] correspond to RG6:0] in the MVD32 data word

Pin DIOC[0] correspond to D[3] in the MVD32 data word

Pins DIOB[7:1] correspond to G[6:0] in the MVD32 data word

Pin DIOB[0] correspond to D[2] in the MVD32 data word

Pins DIOA[7:6] correspond to D[1:0] in the MVD32 data word

Pins DIOA[5:0] correspond to P[5:0] in the MVD32 data word

Pin PCLK1 is the data clock input from the MVD framebuffer

Pins ACK1, and REQ1 are the data handshaking pins. The ACK1 pin is asserted when the card is ready to send data, and the REQ1 signal is asserted when the framebuffer is ready to receive data. Both signal must be asserted for data transfer to occur.

Pin PCLK2 is an output pin that signals the data transfer mode: HIGH indicates plane transfer mode, LOW indicates block transfer mode. This signal is only detected by the framebuffer between data transfers.

Pins ACK2 and REQ2 are the volume handshaking signals. The framebuffer asserts REQ2 when it is ready to receive a new volume of data in either plane transfer mode or block transfer mode. The mvdTransfer API function checks for a HIGH condition on REQ2 before beginning a transfer. If a HIGH condition is found, the function toggles

ACK2 first HIGH then LOW to tell the MVD framebuffer that transfer is about to begin. Transfer follows immediately.

The rest of the pins are either ground (GND) as indicated or have no MVD function.

D. SGI Device Driver source code

The following pages contain the source code an SGI IRIX 6.2 device driver for the National Instruments PCI-DIO-32HS high speed data transfer card.

```

/*****
****          P C I - D I O - 3 2 H S   P C I Device Driver          ****
****
****
****
*/
#include <sys/types.h>
#include "sys/cmn_err.h"
#include "sys/sem.h"
#include <sys/param.h>
#include <sys/errno.h>
#include <sys/syslog.h>
#include <sys/conf.h>
#include <sys/pio.h>
#include "sys/system.h"
#include <sys/time.h>
#include <sys/ksynch.h>
#include <sys/ktime.h>
#include <sys/invent.h>
#include <sys/kmem.h>
#include <sys/kabi.h>
#include <sys/mload.h>
#include <sys/ddi.h>
#include <sys/cred.h>
#include <sys/immu.h>
#include <sys/region.h>
#include <sys/alenlist.h>
#include <sys/ioerror.h>
#include <sys/PCI/PCI_defs.h>
#include <sys/PCI/pciio.h>

#include "diodrvr.h"
#include "diodrvr_user.h"

/* ddi/dki and irix required */
char *diodrvr_mversion = M_VERSION; /* loadable driver requirement */
int diodrvr_devflag = D_MP; /* ddi/dki requirement */

/* =====
 * Device Driver/PCI entry routines
 * ===== */
int diodrvr_unload(void);
int diodrvr_open(dev_t *, int, int, cred_t *);
int diodrvr_close(dev_t, int, int, cred_t *);
int diodrvr_read(dev_t, uio_t *, cred_t *);
int diodrvr_write(dev_t, uio_t *, cred_t *);
int diodrvr_ioctl(dev_t, int, void *, int, cred_t *, int *);
int diodrvr_map ( dev_t, vhandl_t *, off_t, size_t, uint_t );
int diodrvr_unmap ( dev_t, vhandl_t * );
int diodrvr_init();
int diodrvr_reg(void);
int diodrvr_reg(void);

int diodrvr_attach(vertex_hdl_t);
int diodrvr_detach(vertex_hdl_t);

/* =====
 * Helper functions
 * ===== */
void diodrvr_reset(card_t *);
void diodrvr_burst_clkout(card_t *, int *);
void diodrvr_burst_clkout(card_t *, int *);
void diodrvr_dma_group1(card_t *, int *);
static int diodrvr_Strategy ( buf_t * );
static diodrvr_dmapage_t * diodrvrMakeChain ( card_t *, alenlist_t, int);
static void diodrvrStartProgDma ( card_t *, iopaddr_t, int, int);
static void diodrvrStartSingleDma ( card_t *, alenaddr_t, size_t, int );
static void diodrvrTimeOut ( card_t * );
void diodrvr_int_countexp(card_t * );

```



```

if ,( ret ) {
    cmn_err (CE_WARN, "diodrvr_reg: registration returned %d" , ret );
}

return(ret);
}

```

```

/*****
***          d i o d r v r _ a t t a c h          ***
*****/
*
* Name:          diodrvr_attach
*
* Purpose:      Called by the kernel. Our card is installed and hence
*               we are called. Prepare everything necessary to handle
*               the card. Note that when the card is found, the following
*               is set in the Command field of Config space:
*               - Bus master enabled/
*               - Memory and IO space access enabled.
*               - Cache line is set to 0x20 (32)
*               - Latency Timer is set to 0x30 (48)
*
*               For Chameleon, beside Configuration address space, we need 4
*               Memory address spaces to be mapped:
*               Base_Reg 0 = MITE Registers and Fifos
*               Base_Reg 3 = Normal DMA registers
*               Base_Reg 4 = Configuration Register.
*
* Returns:      0 for Success, or errno
*
*****/

```

```

int
diodrvr_attach(vertex_hdl_t conn)
{
    card_t          *cp;
    caddr_t         cfg_adr, mem_ptr, mite_adr, dio_adr, norm_adr;
    pciio_piomap_t  cfg_map, mite_map, dio_map, norm_map;
    register int    ret, i;
    uint_t          vendor_id, device_id, base_reg, cmd_reg, tmp_int;
    vertex_hdl_t    diodrvr_vhdl;
    device_desc_t   dev_desc;
    long            dev_win_data;
    long            testlong;
    char            testchar;
    register uint_t LCR2bits, MGARbits, PLIVRbits;
    register uint_t blklim, cacheLineWords;

    /* dev_desc = device_desc_default_get(conn); */
    dev_desc      = 0;

    pciio_priority_set (conn, PCI_PRIO_HIGH);

    /* =====
    * Configuration Space
    * ===== */

    cfg_map = (pciio_piomap_t)NULL;
    cfg_adr = (caddr_t)pciio_piomap_addr (
        conn,          /* connection vertex          */
        dev_desc,     /* default device descr.    */
        PCIIO_SPACE_CFG, /* dioig space wanted      */
        0,            /* from the start of space */
        DIODRVR_CONFIG_HDR, /* for this many bytes     */
        &cfg_map,     /* in case we need piomap  */
        0);          /* unused flag              */

    if ( cfg_adr == (caddr_t)NULL ) {
        if ( cfg_map ) pciio_piomap_done ( cfg_map );
    }
}

```

```

        cmn_err ( CE_WARN, "diodrvr_attach: Cannot get to Config space" );
    }
    return(EIO);
}

/* =====
 * Configuration data printout
 * ===== */

/* vendor_id, device_id */
tmp_int = Inp32(cfg_adr);
vendor_id = tmp_int & 0x0000ffff;
device_id = tmp_int >> 16;

#ifdef DEBUG
printf ("diodrvr_attach: Config values\n");
printf ("vendor_id = 0x%x, device_id = 0x%x\n", vendor_id, device_id );

/* command and status */
tmp_int = Inp32(cfg_adr + 0x04);
printf ("Command = 0x%x, Status = 0x%x\n", (tmp_int & 0x0000ffff),
        (tmp_int >> 16) );

/* interrupt line and pin */
tmp_int = Inp32(cfg_adr + 0x3C);
printf ("Int Line = %d, Int Pin = %d\n", (tmp_int & 0x000000ff),
        (tmp_int & 0x0000ff00) >> 8 );

/* set the cache line size and latency timer */
tmp_int = Inp32(cfg_adr + 0x0C);
tmp_int = (tmp_int & 0xFFFF0000) | 0xFF20;
Out32(cfg_adr + 0x0C, tmp_int);

/* cache line size and latency timer */
tmp_int = Inp32(cfg_adr + 0x0C);
printf ("Cache line size = %d, latency timer = %d\n",
        (tmp_int & 0x000000ff), (tmp_int & 0x0000ff00) >> 8 );

/* all 6 base registers */
for ( i = 0; i < 6; i++ ) {
    printf ("Base_Reg_%d = 0x%x\n", i, Inp32(cfg_adr+0x10+(i*4)) );
}

dev_win_data = (Inp32(cfg_adr+0x14) & 0xffffffff00) | 0x80;
printf("dev_win_data: 0x%x\n", dev_win_data);

#endif

/* =====
 * MITE Registers
 * ===== */

/* Get MITE Register addresses */
mite_map = (pciio_piomap_t)NULL;
mite_adr = (caddr_t)pciio_pio_addr (
    conn, /* connection vertex */
    dev_desc, /* default device descr. */
    PCIIIO_SPACE_WIN(0), /* Base register 0 space */
    0, /* from the start of space */
    MITE_RAM_SIZE, /* for this many bytes */
    &mite_map, /* in case we need piomap */
    0); /* unused flag */

if ( mite_adr == (caddr_t)NULL ) {
    cmn_err(CE_WARN, "diodrvr_attach: Cannot get to MITE address space" );
    if ( cfg_map ) pciio_piomap_done ( cfg_map );
    if ( mite_map ) pciio_piomap_done ( mite_map );
    return (EIO);
}

```

```

/* write the DIO devices address in the MITE */
Out32(mite_adr + MITE_DEV_WIN, dev_win_data);

/* set max retries to infinite
MGARbits = Inp32(mite_adr + MITE_MGAR);
MGARbits = MGARbits | (MITE_MGAR_DISABLEMAX);
Out32(mite_adr + MITE_MGAR, MGARbits); */

/* match the MITE cache width to the processor cache width
PLIVRbits = Inp32(mite_adr + MITE_PLIVR);
cacheLineWords = (PLIVRbits & 0x000000FF)/4;

switch(cacheLineWords) {
    case 2:
        blklim = MITE_LCR2_BLKCLIM_2;
        break;
    case 4:
        blklim = MITE_LCR2_BLKCLIM_4;
        break;
    case 8:
        blklim = MITE_LCR2_BLKCLIM_8;
        break;
    case 16:
        blklim = MITE_LCR2_BLKCLIM_16;
        break;
    default:
        blklim = 0xFFFFFFFF;
        break; /*
}
if (blklim != 0xFFFFFFFF) { /*

    blklim = MITE_LCR2_BLKCLIM_8;
    LCR2bits = Inp32(mite_adr + MITE_LCR2);
    /* mask out old values */
    LCR2bits &= ~(MITE_LCR2_BLKCLIM | MITE_LCR2_BLKOBND);
    /* now write new values */
    LCR2bits |= (blklim | MITE_LCR2_BLKOBND);
    Out32(mite_adr + MITE_LCR2, LCR2bits);

}

DMA_BASE_ADDR = (dmaChannel * 0x0100L) + (uchar_t *)mite_adr + 0x500;

/* =====
 *      DIO Registers
 * ===== */
dio_map = (pciio_piomap_t)NULL;
dio_adr = (caddr_t)pciio_piomap_addr (
    conn,                                /* connection vertex */
    dev_desc,                             /* default device descr. */
    PCIIO_SPACE_WIN(1), /* Base register 1 space */
    0, /* from the start of space */
    DIO_RAM_SIZE, /* for this many bytes */
    &dio_map, /* in case we need piomap */
    0); /* unused flag */

if ( dio_adr == (caddr_t)NULL ) {
    cmn_err(CE_WARN, "diodrivr_attach: Cannot get to Config Register");
    if ( cfg_map ) pciio_piomap_done ( cfg_map );
    if ( mite_map ) pciio_piomap_done ( mite_map );
    if ( dio_map ) pciio_piomap_done ( dio_map );
    return (EIO);
}

/* Test the card by reading the test registers */
printf("dio test data: 0x%x\n", Inp32(dio_adr+24));

```

```

/* allocate an internal structure for this card and save everything */
cp = (card_t *)kmem_zalloc ( sizeof(card_t), KM_NOSLEEP );
if ( cp == (card_t *)NULL ) {
    cmn_err(CE_WARN, "diodrivr_attach: Cannot allocate memory");
    if ( cfg_map ) pciio_piomap_done ( cfg_map );
    if ( mite_map ) pciio_piomap_done ( mite_map );
    if ( dio_map ) pciio_piomap_done ( dio_map );
    return(ENOMEM);
}

#ifdef DEBUG
printf ("diodrivr_attach: mite_adr = 0%x,      dio_adr = 0%x\n",
        mite_adr, dio_adr );
printf ("          cfg_adr = 0%x\n",
        cfg_adr);

printf ("Maps allocated: %s %s %s\n",
        mite_map ? "MITE":"",
        dio_map ? "dio":"",
        cfg_map ? "Cfg":"" );
#endif

cp->conn      = conn;
cp->cfg_adr   = cfg_adr;
cp->mite_adr  = mite_adr;
cp->dio_adr   = dio_adr;

cp->mite_map  = mite_map;

cp->dio_map   = dio_map;
cp->cfg_map   = cfg_map;
cp->kernel_abi = get_current_abi(); /* ABI_IRIX5_64 for 64-bit kernel */

/* reset the card */
diodrivr_reset( cp );

/* Test the card by writing to the output registers */
printf("attempting to test output channels\n");
Out32(dio_adr+32, 0);
Out32(dio_adr+36, 0);
Out32(dio_adr+32, 0xffffffff);

testlong = 0xffffffff;
testchar = 0xff;

/*
for(i=0;i<21;i++)
{
    Out32(dio_adr+28, testlong);
    testlong = testlong ^ 0xffffffff;
    testchar = testchar ^ 0xff;
}
*/

/* initialize our mutex lock and sv_t for sleep/wake */
DIODRVR_LOCK_INIT(&cp->diodrivr_mlock);
SV_INIT(&cp->diodrivr_sv, SV_DEFAULT, "diodrivrsv" );

/* create a vertex for our device off of the connection point */
ret = hwgraph_char_device_add(conn, "diodrivr", "diodrivr_", &diodrivr_vhdl );
if ( ret != GRAPH_SUCCESS ) {
    cmn_err (CE_WARN, "diodrivr_attach: could not addr vertex");
    if ( cfg_map ) pciio_piomap_done ( cfg_map );
    if ( mite_map ) pciio_piomap_done ( mite_map );
    if ( dio_map ) pciio_piomap_done ( dio_map );

    kmem_free ( cp, sizeof(card_t) );
    return(EIO);
}

```

```

hwgraph_chmod( diodrvr_vhdl, 0666 );
cp->vhdl      = diodrvr_vhdl;

/* once iodioig and DIODRVR_MKHWGRAPH works, remove this area */
ret = hwgraph_edge_add ( hwgraph_root, diodrvr_vhdl, "diodrvr" );
if ( ret != GRAPH_SUCCESS ) {
    cmn_err (CE_WARN, "diodrvr_attach: Cannot create node /hw/diodrvr");
}

/* =====
 *      Interrupt Handler Registration
 * ===== */
cp->dev_intr = pciio_intr_alloc ( conn, dev_desc,
                                PCIIO_INTR_LINE_A,
                                diodrvr_vhdl );

if (cp->dev_intr == (pciio_intr_t)NULL){
    cmn_err(CE_WARN, "diodrvr_attach: Can't pciio_intr_alloc");
    if ( cfg_map ) pciio_piomap_done ( cfg_map );
    if ( mite_map ) pciio_piomap_done ( mite_map );
    if ( dio_map ) pciio_piomap_done ( dio_map );

    kmem_free ( cp, sizeof(card_t) );
    hwgraph_edge_remove(conn, "diodrvr", &diodrvr_vhdl);
    device_info_set ( diodrvr_vhdl, 0 );
    hwgraph_vertex_destroy ( diodrvr_vhdl );
    return(EIO);
} /* if can't allocate interrupt handler */

ret = pciio_intr_connect ( cp->dev_intr, (intr_func_t)diodrvr_intr,
                          (intr_arg_t)cp, 0 );

if ( ret != 0 ) {
    cmn_err(CE_WARN, "diodrvr_attach: Cannot register interrupt handler");
    if ( cfg_map ) pciio_piomap_done ( cfg_map );
    if ( mite_map ) pciio_piomap_done ( mite_map );
    if ( dio_map ) pciio_piomap_done ( dio_map );

    kmem_free ( cp, sizeof(card_t) );
    hwgraph_edge_remove(conn, "diodrvr", &diodrvr_vhdl);
    device_info_set ( diodrvr_vhdl, 0 );
    hwgraph_vertex_destroy ( diodrvr_vhdl );
    return (EIO);
} /* if can't connect to interrupt line */

/* =====
 *      Register an error handler for 6.4
 * ===== */

#if 0
pciio_error_register(conn, (error_handler_f *)diodrvr_error, cp );
#endif

cp->status      = CARD_ATTACHED;

/* allocate memory for mapping
for ( i = MAP_PAGES; i > 0; i-- ) {
    cp->mappedkv = kmem_alloc ( i * NBPP,
                              KM_NOSLEEP | KM_PHYSCONTIG | KM_CACHEALIGN);
    if ( cp->mappedkv != (caddr_t)NULL )
        break;
}
if ( cp->mappedkv == (caddr_t)NULL ) {
    cmn_err (CE_NOTE, "diodrvr_attach: Not enough memory for mapping");
    cmn_err (CE_WARN, "diodrvr_attach: No mapping is allowed");
}
else {
    cp->mappedkvlen = i * NBPP;

```

```

    cmn_err (CE_NOTE, "diodrvr_attach: %d bytes allocated, %d available for mapping",
            cp->mappedkvlen, cp->mappedkvlen - LESS_MAP );
} */

/* save our structure */
device_info_set ( diodrvr_vhdl, (void *)cp );

cmn_err ( CE_NOTE, "diodrvr_attach: driver is ready" );
return(0);
}

```

```

/*****
***          d i o d r v r _ d e t a c h          ***
*****/
*
* Name:          diodrvr_detach
*
* Purpose:       Detaches a driver. Called by the pciio infrastructure
*                once for each vertex representing a crosstalk widget
*                when unregistering the driver.
*
* Returns:       0 Success or errno
*
*****/

```

```

int
diodrvr_detach(vertex_hdl_t conn)
{
    register card_t      *cp;
    vertex_hdl_t        vhdl;

    if ( hwgraph_traverse(conn, "diodrvr", &vhdl) != GRAPH_SUCCESS )
        return(-1);

    hwgraph_vertex_unref(vhdl); /* update the ref count for above call */
    cmn_err(CE_NOTE,
            "diodrvr_detach: Unregister Interrupt handler and free up mem" );

    cp = (card_t *)device_info_get ( vhdl );

    /* our struct is there ? clean up our driver's stuff */
    if ( cp != (card_t *)NULL ) {

        /* free up memory for mapping */
        if ( cp->mappedkv )
            kmem_free ( cp->mappedkv, cp->mappedkvlen );

        /* Unregister the Interrupt Handler */
        pciio_intr_disconnect(cp->dev_intr);
        pciio_intr_free(cp->dev_intr);

        #if 0
            /* unregister error handler */
            pciio_error_register(conn, 0, 0);
        #endif

        /* free up all our maps */
        if ( cp->cfg_map ) pciio_piomap_done ( cp->cfg_map );
        if ( cp->mite_map ) pciio_piomap_done ( cp->mite_map );
        if ( cp->dio_map ) pciio_piomap_done ( cp->dio_map );

        /* free up the struct itself */
        kmem_free ( cp, sizeof(card_t) );

    }

    /* free up our vertexes */
    hwgraph_edge_remove ( hwgraph_root, "diodrvr", NULL );
    hwgraph_edge_remove(conn, "diodrvr", NULL );
}

```

```

device_info_set ( vhdl, 0 );
hwgraph_vertex_unref( vhdl );
hwgraph_vertex_destroy ( vhdl );

```

```

return(0);
}

```

```

/*****
***                               d i o d r v r _ i n t r                               ***
****                               ****
*
* Name:          diodrvr_intr
*
* Purpose:       Our interrupt handler.
*
* Returns:       None.
*
*****/

```

```

void

```

```

diodrvr_intr( intr_arg_t arg )

```

```

{
    register card_t      *cp;
    register buf_t      *bp;
    register caddr_t     mite_adr_mite, dio_adr;

    register uint_t     intcsr, CHORbits, CHCRbits;
    register int        i, rw, err;
    register int        s;
    size_t              p_size;
    alenaddr_t          p_addr;
    register int        count;
    register int        offset;
    size_t              size;
    alenaddr_t          addr;
    alenlist_t          unmappedList, mappedList;

    register uint_t     DMA_FLAGS = PCIIO_DMA_DATA | PCIIO_PREFETCH;

    unmappedList = alenlist_create( AL_NOCOMPACT );
    mappedList = alenlist_create( AL_NOCOMPACT );

    /* get the lock */
    cp = (card_t *)arg;
    nanotime ( & cp->intr_time);
    s = DIODRVR_LOCK(&cp->diodrvr_mlock);

    /* a stray interrupt ? */
    dio_adr = cp->dio_adr;
    intcsr = Inp8(dio_adr + (Group_1_Flags^3));
    if ( (intcsr & 0xE3) == 0 ) {
        DIODRVR_UNLOCK(&cp->diodrvr_mlock, s);
        return;
    }

    /* report interrupt */
#ifdef DEBUG
    printf ("diodrvrIntr: Count Expired\n");
#endif

    bp = cp->bp;

    /* cancel any outstanding timer */
    printf("cancel timer\n");
    if ( cp->tid > 0 ) {
        untimeout(cp->tid);
        cp->tid = 0;
    }
}

```

```

/* reset the MITE Interrupt */
CHCRbits = (unsigned int) (DMA_CHCR_CLR_DONE_IE | DMA_CHCR_CLR_DMA_IE);
Out32(DMA_BASE_ADDR + DMA_CHCR, CHCRbits);

/* reset the DIO interrupt */
Out8(cp->dio_adr + (Group_1_First_Clear^3), 0xF8); /* bits 4,5, 7 */
Out8(cp->dio_adr + (Group_1_Second_Clear^3), 0x03);

/* disarm the DMA and reset the MITE */
CHORbits = (DMA_CHOR_DMARESET | DMA_CHOR_FRESET | DMA_CHOR_ABORT |
DMA_CHOR_CLR_SEND_TC);
Out32(DMA_BASE_ADDR + DMA_CHOR, CHORbits);

/* stop the DIO */
Out8(dio_adr + (Protocol_Register_1_Group_1^3), 0x0);

/* single page DMA done. DMA the next page if any */
if (cp->dmatype == DMA_PAGE) {

    bp->b_resid -= cp->dmasize;
    cp->page_no--;

    if ( cp->page_no <= 0 ) { /* no more pages */

        #ifdef DEBUG
            printf ("diodrvrIntr: No more pages to Dma\n");
            printf ("diodrvrIntr: biodone() read/write\n");
        #endif

        alenlist_done( cp->addrList );
        alenlist_done( cp->alenList );

        cp->addrList = 0;
        cp->alenList = 0;

        cp->dmastat = DMA_IDLE;

        /* free our DMA maps */
        pciio_dmamap_free(cp->buffer_map);
        pciio_dmamap_free(cp->link_map);

        /* reset the DIO */
        Out8(dio_adr + (Protocol_Register_1_Group_1^3), 0x0);

        biodone(cp->bp);
        DIODRVR_UNLOCK(&cp->diodrvr_mlock, s);
        goto get_out;
    }

    /* get next page to DMA */
    #ifdef DEBUG
        printf ("diodrvrIntr: DMA next page ..left = %d\n", cp->page_no-1 );
    #endif

    /* set up alenlist for next DMA page */
    count = 0;
    i = 0;
    for ( ;; ) {
        if ( alenlist_get(cp->alenList, NULL, NBPP, &addr, &size, 0) !=
            ALENLIST_SUCCESS ) {
            break;
        }
        if ((count += size) == cp->dma_page_size) {
            /*offset = alenlist_cursor_offset( cp->addrList, NULL );
            alenlist_cursor_init ( cp->addrList, offset -
sizeof(alenlist_t), NULL);*/
            break;
        }
    }
    printf("setting up DMA page in Intr i: %d  count: 0x%x  addr: 0x%x\n",

```

```

i, count, addr);

        alenlist_append(unmappedList, addr, size, AL_NOCOMPACT);

        i++;
    } /* for (;;) */

alenlist_cursor_init ( unmappedList, NULL, NULL );

pciio_dmamap_done( cp->buffer_map );

mappedList = pciio_dmamap_list ( cp->buffer_map, unmappedList, DMA_FLAGS);

if ( mappedList == (alenaddr_t)NULL ) {
    cmn_err (CE_NOTE, "diodrvrStrategy: Cannot create alenlist");
    bioerror ( bp, EIO);
    biodone (bp);
    pciio_dmamap_free(cp->buffer_map);
    pciio_dmamap_free(cp->link_map);
}

alenlist_cursor_init ( mappedList, NULL, NULL );
alenlist_get( mappedList, NULL, NBPP, &p_addr, &p_size, 0);
p_size = count;

printf("start single page DMA of size: 0x%x   addr: 0x%x\n" , p_size, p_addr);

if ( (p_addr < 0x30000000) || (p_addr > 0x50000000) ) {
    cmn_err (CE_NOTE, "diodrvrStrategy: Incorrect DMA mapping. Exiting
driver!!");

    alenlist_done( cp->alenList );
    alenlist_done( mappedList );

    pciio_dmamap_free( cp->buffer_map );
    pciio_dmamap_free( cp->link_map );

    bioerror ( bp, EIO);
    biodone (bp);
    DIODRVR_UNLOCK(&cp->diodrvr_mlock, s);

    goto get_out;
}

if ( cp->dmastat == DMA_READ_WAIT )
    rw = B_READ;
else rw = B_WRITE;

diodrvr_int_countexp( cp );

diodrvrStartSingleDma ( cp, p_addr, p_size, rw );

if ( rw == B_READ )
    cp->dmastat = DMA_READ_WAIT;
else cp->dmastat = DMA_WRITE_WAIT;
cp->chain_list = NULL;

/* so we don't wait forever for an interrupt */
cp->tid = itimeout(diodrvrTimeOut, cp, RW_TIMER, pltimeout, 0, 0, 0);

DIODRVR_UNLOCK(&cp->diodrvr_mlock, s);

goto get_out;

} /*** if ( cp->dmatype == DMA_PAGE ) ***/

/* free up chain list structure */
if (cp->dmatype == DMA_CHAIN)
    kmem_free ( cp->chain_list, cp->page_no * sizeof(diodrvr_dmapage_t) );

```

```

alenlist_done( cp->addrList );
alenlist_done( cp->alenList );

cp->addrList = 0;
cp->alenList = 0;

cp->dmastat = DMA_IDLE;
bp->b_resid -= cp->dmasize;

/* free our DMA maps */
pciio_dmamap_free(cp->buffer_map);
pciio_dmamap_free(cp->link_map);

/* reset the DIO */
Out8(dio_adr + (Protocol_Register_1_Group_1^3), 0x0);

biodone (cp->bp);
DIODRVR_UNLOCK(&cp->diodrvr_mlock, s);

```

```
get_out:
```

```

#ifdef DEBUG
printf ( "diodrvrIntr exit\n" );
#endif

```

```
}
```

```

/*****
***          d i o d r v r _ u n l o a d          ***
*****/
*
* Name:          diodrvr_unload
*
* Purpose:       Unloads the driver.
*
* Returns:       0 Success or errno
*
*****/

```

```

int
diodrvr_unload(void)
{
    cmn_err (CE_NOTE, "Unloading the PCI_DIO_32HS Driver");
    return(0);
}

```

```

/*****
***          d i o d r v r _ u n r e g          ***
*****/
*
* Name:          diodrvr_unreg
*
* Purpose:       Unregister the driver
*
* Returns:       0 Success or errno
*
*****/

```

```

int
diodrvr_unreg(void)
{
    cmn_err (CE_NOTE, "Unregisterng PCI-DIO-32HS Driver");
    pciio_driver_unregister(DRIVER_PREFIX);

    return(0);
}

```

```

/*****
***          d i o d r v r _ o p e n          ***
*****/

```

```

*
* Name:      diodrvr_open
*
* Purpose:   Opens the card. This sample driver simply verifies that
*            the card's info structure can be retrieved and checks
*            the card's Base_Register.
*
* Returns:   0 = Success, or errno.
*
*****/

```

```

int
diodrvr_open(dev_t *devp, int flag, int otyp, cred_t *cred)
{
    register card_t      *cp;
    register vertex_hdl_t vhdl;
    __userabi_t          uabi;

    /* Get the vertex handle and pointer to card's info */
    vhdl = dev_to_vhdl ( *devp );
    if (vhdl == NULL){
        cmn_err(CE_WARN, "diodrvr_open: dev_to_vhdl returns NULL");
        return(EIO);
    }

    cp = (card_t *)device_info_get ( vhdl );

    /* some error checking first */
    if ( !(cp->status & CARD_ATTACHED) ) {
        cmn_err (CE_WARN, "diodrvr_open: Driver is not attached");
        return (ENODEV);
    }

    if ( cp->status & CARD_OPEN) {
        cmn_err (CE_WARN, "diodrvr_open: Device is busy");
        return (EBUSY);
    }

    /* diodrvrReset(cp); reset the board */
    cp->status |= CARD_OPEN;

    /* default values */
    cp->dmatype = DMA_PAGE;
    /* cp->dmacmd = DIODRVR_TRANSP; */

#ifdef DEBUG
    printf("\n *** DIO card opened *** \n");
#endif

    /* get user's ABI for correct struct usage in diodrvr_ioctl() */
    userabi(&uabi);
    if ( uabi.uabi_sziptr == 8 )
        cp->user_abi = ABI_IRIX5_64;
    else
        cp->user_abi = ABI_IRIX5_N32;

    /* initialize our mutex lock and sv_t for sleep/wake */
    DIODRVR_LOCK_INIT(&cp->diodrvr_mlock);
    SV_INIT(&cp->diodrvr_sv, SV_DEFAULT, "diodrvrsv" );

    /* zero out all time measurements */
    bzero ( &cp->start_time, sizeof(struct timespec) );
    bzero ( &cp->intr_time, sizeof(struct timespec) );
    bzero ( &cp->call_time, sizeof(struct timespec) );
    bzero ( &cp->ret_time, sizeof(struct timespec) );

    return(0);
}

```

```

/*****
***                               d i o d r v r _ c l o s e                               ***
****
*
* Name:          diodrvr_close
*
* Purpose:       Closes the card. This sample driver's close statement
*                prints out the addresses and Base_Register's value for
*                verification.
*
* Returns:       0 = Success, or errno
*
*****/
int
diodrvr_close(dev_t dev, int flag, int otyp, cred_t *cred)
{
    register card_t      *cp;
    register vertex_hdl_t vhdl;

    /* get the vertex handle and pointer to card's info */
    vhdl = dev_to_vhdl ( dev );

    cp = (card_t *)device_info_get ( vhdl );
    cp->status &= ~CARD_OPEN;

    /* zero out all time measurements */
    bzero ( &cp->start_time, sizeof(struct timespec) );
    bzero ( &cp->intr_time,  sizeof(struct timespec) );
    bzero ( &cp->call_time,  sizeof(struct timespec) );
    bzero ( &cp->ret_time,   sizeof(struct timespec) );

    return(0);
}

/*****
***                               d i o d r v r _ m a p                               ***
****
*
* Name:          diodrvr_map
*
* Purpose:       Allocate a piece of continuous memory and map it to user's
*                address space.
*
* Returns:       0 = Success, or errno
*
*****/
int
diodrvr_map ( dev_t dev, vhandl_t *vh, off_t offset, size_t len, uint_t prot )
{
    register int          ret;
    register int          s;
    register caddr_t      kv;
    register vertex_hdl_t vhdl;
    register card_t       *cp;

    /* get the vertex handle and pointer to card's info */
    vhdl = dev_to_vhdl ( dev );
    cp = (card_t *)device_info_get ( vhdl );

    if ( cp->dio_adr == (caddr_t)NULL ) {
        cmn_err (CE_NOTE, "diodrvr_map: No DIO memory for mapping");
        return (ENOMEM);
    }

    if ( len > (size_t)(DIO_RAM_SIZE) ) {
        cmn_err (CE_NOTE, "diodrvr_map: Only %d bytes available for map, requested %d
bytes", DIO_RAM_SIZE, len );
        return (ENOMEM);
    }
}

```

```

ret = v_mapphys( vh, (void *)cp->dio_adr, len );

if ( ret > 0 ) {
    cmn_err (CE_WARN, "diodrvr_map: Could not map, ret = %d", ret );
    return (ret);
}

/* save for later */
cp->vhandl = vh;

cmn_err (CE_NOTE, "diodrvr_map: mapped %d bytes", len );
return (ret);
}

```

```

/*****
***          d i o d r v r _ u n m a p          ***
*****/

```

```

*
* Name:          diodrvr_unmap
*
* Purpose:       Unmap the kernel buffer we allocated before.
*
* Returns:       Always 0. There is nothing to free up here.
*
*****/

```

```

int
diodrvr_unmap ( dev_t dev, vhandl_t *vh )
{
    return (0);
}

```

```

/*****
***          d i o d r v r _ i o c t l          ***
*****/

```

```

*
* Name:          diodrvr_ioctl
*
* Purpose:       Handles user Ioctl command. These commands can be
*                found in diodrvr_user.h.
*
* Returns:       0 = Success, or errno
*
*****/

```

```

int
diodrvr_ioctl( dev_t dev, int cmd, void *arg, int mode, cred_t *cred,
               int *rvalp )
{

```

```

    register card_t      *cp;
    register vertex_hdl_t vhd1;
    register uint_t      *tmp_ibuf;
    register int         tot_bytes, err, i, s;
    uint_t               tmp_int;

```

```

/* get the vertex handle and pointer to card's info */
vhd1 = dev_to_vhd1 ( dev );

```

```

cp = (card_t *)device_info_get ( vhd1 );

```

```

if ( cp == (card_t *)NULL ) {
    cmn_err (CE_WARN, "diodrvr_ioctl: Card_t is NULL");
    return (EIO);
}

```

```

/* is device opened ? */
if (!( cp->status & CARD_OPEN ) ) {
    cmn_err (CE_NOTE, "diodrvr_ioctl: Device is not opened");
    return (EIO);
}

```

```

}

/* #ifdef DEBUG
printf("ioctl arg: 0x%x\n", *((int *)arg));
#endif */

```

```

/* =====
*   Ioctl commands
* ===== */

```

```

switch ( cmd ) {

    case DIODRVR_RESET:
        diodrvr_reset ( cp );
        break;

    case DIODRVR_BURST_CLKOUT:
        diodrvr_burst_clkout ( cp, arg );
        break;

    case DIODRVR_BURST_CLKIN:
        diodrvr_burst_clkin ( cp, arg );
        break;

    case DIODRVR_DMA_GROUP1:
        diodrvr_dma_group1 ( cp, arg );
        break;

    case DIODRVR_INTR_COUNTEXP:
        diodrvr_int_countexp ( cp );
        break;

    case DIODRVR_RUN:
        diodrvr_run ( cp );
        break;

    case DIODRVR_STOP:
        diodrvr_stop ( cp );
        break;

    case DIODRVR_GETTIME:
        diodrvrUserTime ( cp, arg );
        break;

} /** end switch */

return(0);
}

```

```

/*****
***           d i o d r v r _ r e a d           ***
*****/
*
* Name:           diodrvr_read
*
* Purpose:        Read entry routine. DMAs data from the board to the
*                  user's address space.
*
* Returns:        0 = Success, or errno
*
*****/

```

```

int
diodrvr_read( dev_t dev, uio_t *uiop, cred_t *crp)
{
    register card_t *cp;
    register vertex_hdl_t vhdl;
    register int    ret;

    /* get to the board's info structure */

```

```

, vhdl = dev_to_vhdl ( dev );

cp = (card_t *)device_info_get ( vhdl );
cp->bp = (buf_t *)NULL;
cp->addrList = 0;
cp->dmastat = 0;
cp->dmabits = 0;

/* do the transfer */

ret = uiophysio ( diodrvr_Strategy, NULL, dev, B_READ, uiop );

ret = 0;

if ( cp->addrList ) {
    alenlist_done(cp->addrList);
    cp->addrList = 0;
}

#ifdef DEBUGTIME
diodrvrReportTime ( "diodrvrRead", cp, 1);
#endif

return ( ret );
}

/*****
***          d i o d r v r _ w r i t e          ***
*****/
*
* Name:          diodrvr_write
*
* Purpose:       Write entry routine. DMAs data from user's address space
*                to the board.
*
* Returns:       0 = Success, or errno
*
*****/
int
diodrvr_write( dev_t dev, uio_t *uiop, cred_t *crp)
{
    register card_t      *cp;
    register vertex_hdl_t vhdl;
    register int         ret;

    /* get to the board's info structure */
    vhdl = dev_to_vhdl ( dev );
    cp = (card_t *)device_info_get ( vhdl );
    cp->bp      = (buf_t *)NULL;
    cp->dmastat = 0;
    cp->dmabits = 0;
    cp->addrList = 0;

    cp->dmatype = DMA_PAGE;

    bzero ( &cp->start_time, sizeof(struct timespec) );
    bzero ( &cp->intr_time,  sizeof(struct timespec) );
    bzero ( &cp->call_time,  sizeof(struct timespec) );
    bzero ( &cp->ret_time,   sizeof(struct timespec) );

    printf("entering diodrvrWrite routine\n");

    /* do the transfer */
    nanotime ( &cp->call_time );
    ret = uiophysio ( diodrvr_Strategy, NULL, dev, B_WRITE, uiop );
    nanotime ( &cp->ret_time );

    printf("diodrvr_Write: returned from diodrvrStrategy: %d\n", ret);
}

```

```
if ( cp->addrList ) {
    alenlist_done(cp->addrList);
    cp->addrList = 0;
}

#ifdef DEBUGTIME
    diodrvrReportTime ( "diodrvr_Write", cp, 1);
#endif

printf("diodrvr_Write: returning from driver: %d\n", ret);
return ( ret );
}
```

```
/*
***                               d i o d r v r _ e r r o r                               ***
*****
*
* Name:          diodrvr_error
*
* Purpose:       Traps PCI bus error.
*
* Returns:       0 = Success, or errno
*
*****/
```

```
static int
diodrvr_error(void *einfo,
              int error_code,
              ioerror_mode_t mode,
              ioerror_t *ioerror)
{
    cmn_err (CE_NOTE, "diodrvr_error: called");
    printf ("error_code = %d (0x%x)\n", error_code, error_code );
    printf ("io_errortype = %d\n", ioerror->ie_errortype );
    printf ("io_busspace = %d\n", ioerror->ie_busspace );
    printf ("io_busaddr = 0x%x\n", ioerror->ie_busaddr );
    printf ("io_memaddr = 0x%x\n", ioerror->ie_memaddr );
    printf ("error_mode = %d (0x%x)\n", mode, mode );
    return (IOERROR_UNHANDLED);
}
```

```
/*
~~~~~
~~~~~
~~~~~          S u p p o r t i n g   R o u t i n e s          ~~~~~
~~~~~
~~~~~
*/
```

```
/*
***                               d i o d r v r _ S t r a t e g y                               ***
*****
*
* Name:          diodrvr_Strategy
*
* Purpose:       Strategy routine. It actually handles read/write
*                and starts the DMA. It is called by uiophysio() kernel
*                routine.
*
* Returns:       0 = Success, or errno
*
*****/
```

```
static int
diodrvr_Strategy ( buf_t *bp )
```

```

register card_t                *cp;
register vertex_hdl_t          vhdl, conn;
register diodrvr_dmapage_t     *dmaPg;
register int                    i, ret, rw, tot_bytes;
register int                    s;
register uint_t                 fill_bits;
alenlist_t                     addrList2;
size_t                          p_size;
alenaddr_t                     p_addr;
iopaddr_t                      p_dmaPg;

pciio_dmamap_t                 buffer_map, link_map;
device_desc_t                  dev_desc;

register int                    count;
register int                    offset;
size_t                          size;
alenaddr_t                     addr;

register uint_t                 DMA_FLAGS = PCIIO_PREFETCH |
PCIIO_WRITE_GATHER;

if ( !BP_ISMAPPED(bp) ) {
    cmn_err (CE_NOTE, "diodrvrStrategy: Unmapped buf_t used\n");
    bioerror ( bp, EIO);
    biodone (bp);
    return(EIO);
}

printf("diodrvrStrategy: entering diodrvrStrategy\n");

/* get to the board's info structure */
vhdl = dev_to_vhdl ( bp->b_edev );
cp = (card_t *)device_info_get ( vhdl );
conn = cp->conn;

cp->dma_page_size = 0x40000; /* 256 KB */

printf("diodrvrStrategy: done getting board's info structure\n");

/* clear error and save bp */
bioerror(bp, 0);
bp->b_resid = bp->b_bcount;
cp->bp = bp;

if ( bp->b_flags & B_READ )
    rw = B_READ; /* board -> mem */
else
    rw = B_WRITE; /* mem -> board */

printf("diodrvrStrategy: allocating DMA maps\n");

/* set up mapping device descriptor */
dev_desc = 0;

/* allocate our DMA maps */
buffer_map = pciio_dmamap_alloc( conn, dev_desc, cp->dma_page_size + 0x6000, DMA_FLAGS
);

if ( buffer_map == (pciio_dmamap_t)NULL ) {
    cmn_err (CE_NOTE, "diodrvrStrategy: Cannot create buffer map");
    bioerror ( bp, EIO);
    biodone (bp);
    return(EIO);
}

link_map = pciio_dmamap_alloc( conn, dev_desc, 0x1000, DMA_FLAGS );
if ( link_map == (pciio_dmamap_t)NULL ) {
    cmn_err (CE_NOTE, "diodrvrStrategy: Cannot create link map");
    bioerror ( bp, EIO);
}

```

```

        biodone (bp);
        pciio_dmamap_free(buffer_map);
        return(EIO);
    }

    cp->buffer_map = buffer_map;
    cp->link_map = link_map;

    /* create scatter-gather list */
    cp->alenList = buf_to_alenlist ((alenlist_t)NULL, bp, AL_NOCOMPACT);
    addrList2 = alenlist_clone( cp->alenList, AL_NOCOMPACT);

    cp->addrList_page = alenlist_create( AL_NOCOMPACT );

    if ( (cp->dmatype == DMA_CHAIN) || (cp->dmatype == DMA_SINGLE) ) {
        #ifdef DEBUG
            printf("diodrivrStrategy: translating DMA addresses for link
chaining\n");
        #endif
        cp->addrList = pciio_dmamap_list ( buffer_map, addrList2, DMA_FLAGS);
        if ( cp->addrList == (alenaddr_t)NULL ) {
            cmn_err (CE_NOTE, "diodrivrStrategy: Cannot create alenlist");
            bioerror ( bp, EIO);
            biodone (bp);
            pciio_dmamap_free(buffer_map);
            pciio_dmamap_free(link_map);
            return(EIO);
        }
    }

    printf("diodrivrStrategy: getting alenlist size\n");

    #if 0
        cp->page_no = alenlist_size ( cp->alenList );
    #endif

    if (cp->dmatype == DMA_PAGE) {
        cp->page_no = bp->b_bcount / cp->dma_page_size;
        if ((bp->b_bcount % cp->dma_page_size) !=0)
            (cp->page_no)++;
    }
    else
        cp->page_no = diodrivrAlenlistSize ( cp->alenList );

    printf("diodrivrStrategy: number of pages %d DMAtype: %d\n" , cp->page_no, cp->dmatype
);

    /* =====
    *   Chained DMA
    * ===== */
    if ( cp->dmatype == DMA_CHAIN ) {

        printf("diodrivrStrategy: making chain\n");

        dmaPg = diodrivrMakeChain ( cp, cp->addrList, cp->page_no );

        if ( dmaPg == (diodrivr_dmapage_t *)NULL ) {
            cmn_err (CE_NOTE,
                "diodrivrStrategy: Error creating chain list");
            alenlist_done (cp->addrList);
            bioerror (bp, EIO);
            biodone (bp);
            pciio_dmamap_free(buffer_map);
            pciio_dmamap_free(link_map);
            return(EIO);
        }

        tot_bytes = cp->page_no * sizeof(diodrivr_dmapage_t); /* length of link chain in
bytes */
    }

```

```
p_dmaPg = pciio_dmamap_addr ( link_map, kvtophys(dmaPg), tot_bytes);
```

```
if ( p_dmaPg == (iopaddr_t)NULL) {  
    cmn_err (CE_NOTE,  
            "diodrvrStrategy: Error creating chain list");  
    alenlist_done (cp->addrList);  
    bioerror (bp, EIO);  
    biodone (bp);  
    pciio_dmamap_free(buffer_map);  
    pciio_dmamap_free(link_map);  
    return(EIO);  
}
```

```
#if 0  
/* write back cache for chain list */  
dki_dcachewbinval ( dmaPg, tot_bytes );  
#endif
```

```
/* start the Chained Dma */  
s = DIODRVR_LOCK(&cp->diodrvr_mlock);
```

```
diodrvrStartProgDma ( cp, p_dmaPg, bp->b_bcount, rw );
```

```
/*  
*****  
This is the test section  
*****  
*/
```

```
cp->addrList = pciio_dmamap_list ( buffer_map, cp->alenList, PCIIIO_DMA_DATA);  
if ( cp->addrList == (alenaddr_t)NULL ) {  
    cmn_err (CE_NOTE, "diodrvrStrategy: Cannot create alenlist");  
    bioerror ( bp, EIO);  
    biodone (bp);  
    pciio_dmamap_free(buffer_map);  
    pciio_dmamap_free(link_map);  
    return(EIO);  
}
```

```
alenlist_get( cp->addrList, NULL, NBPP, &addr, &size, 0);
```

```
printf("addr: 0x%x size: 0x%x\n", addr, size);
```

```
if ( (addr < 0x20000000) || (addr > 0x60000000) ) {  
    cmn_err (CE_NOTE, "diodrvrStrategy: Incorrect DMA mapping. Exiting
```

```
driver!!");
```

```
    bioerror ( bp, EIO);  
    biodone (bp);
```

```
    alenlist_done( cp->addrList );  
    alenlist_done( cp->addrList_page );
```

```
    pciio_dmamap_free(buffer_map);  
    pciio_dmamap_free(link_map);  
    return(EIO);  
}
```

```
diodrvrStartSingleDma ( cp, addr, bp->b_bcount, rw );
```

```
*****  
End of test section  
*****/
```

```
if ( rw == B_READ )  
    cp->dmastat = DMA_READ_WAIT;  
else cp->dmastat = DMA_WRITE_WAIT;  
cp->chain_list = (caddr_t)dmaPg;
```

```
printf("diodrvrStrategy: wait for timeout\n");
```

```
/* so we dont wait forever for an interrupt */
```

```

↑
cp->tid = itimeout(diodrvrTimeOut, cp, RW_TIMER, pltimeout, 0, 0, 0);

printf("diodrvrStrategy: unlock memory\n");
DIODRVR_UNLOCK(&cp->diodrvr_mlock, s);

printf("diodrvrStrategy: return to caller\n");
return(0);
} /* end of chained DMA */

/* =====
 *      Single page DMA
 * ===== */

/* get a page to DMA */
if (cp->dmatype == DMA_PAGE) {
    printf("diodrvrStrategy: setting up page to DMA\n");
    count = 0;
    i = 0;
    alenlist_cursor_init ( cp->alenList, NULL, NULL );
    for ( ;; ) {
        if ( alenlist_get( cp->alenList, NULL, NBPP, &addr, &size, 0) !=
            ALENLIST_SUCCESS ) {
            break;
        }

        count += size;
        alenlist_append(cp->addrList_page, addr, size, AL_NOCOMPACT);
        i++;
        printf("setting up DMA page i: %d  count: 0x%x  addr: 0x%x\n", i,
count, addr);

        if (count > cp->dma_page_size) {
            printf("alenlist create reset\n");
            break;
        }
    } /* for (;;) */

    alenlist_cursor_init ( cp->addrList_page, NULL, NULL );

    cp->addrList = pciio_dmamap_list ( buffer_map, cp->addrList_page, DMA_FLAGS);

    if ( cp->addrList == (alenaddr_t)NULL ) {
        cmn_err (CE_NOTE, "diodrvrStrategy: Cannot create map alenlist");
        bioerror ( bp, EIO);
        biodone (bp);
        pciio_dmamap_free(buffer_map);
        pciio_dmamap_free(link_map);
        return(EIO);
    }

    alenlist_get(cp->addrList, NULL, NBPP, &p_addr, &p_size, 0);
    p_size = count;

} /* end if (cp->dmatype == DMA_PAGE) */

else {
    /* only gets here is dmatype == DMA_SINGLE */
    if ( alenlist_get(cp->addrList, NULL, NBPP,
        &p_addr, &p_size, 0) != ALENLIST_SUCCESS ) {
        cmn_err (CE_WARN, "diodrvrDma: Not enough Memory");
        alenlist_done(cp->addrList);
        bioerror ( bp, EIO);
        biodone(bp);
        return(EIO);
    }
}

/* single dma, memory -> board */
printf("start single page DMA of size: 0x%x  addr: 0x%x\n", p_size, p_addr);

```

```

    if ( (p_addr < 0x20000000) || (p_addr > 0x60000000) ) {
        cmn_err (CE_NOTE, "diodrvrStrategy: Incorrect DMA mapping. Exiting
driver!!");

        bioerror ( bp, EIO);
        biodone (bp);
        pciio_dmamap_free(buffer_map);
        pciio_dmamap_free(link_map);
        return(EIO);
    }

    s = DIODRVR_LOCK(&cp->diodrvr_mlock);
    diodrvrStartSingleDma ( cp, p_addr, p_size, rw );

    if ( rw == B_READ )
        cp->dmastat = DMA_READ_WAIT;
    else cp->dmastat = DMA_WRITE_WAIT;

    cp->chain_list = NULL;

    /* so we don't wait forever for an interrupt */
    cp->tid = itimeout(diodrvrTimeOut, cp, RW_TIMER, pltimeout, 0, 0, 0);

    printf("diodrvrStrategy: return from caller\n");
    DIODRVR_UNLOCK(&cp->diodrvr_mlock, s);

    return(0);
}

```

```

/*****
***          d i o d r v r M a k e C h a i n          ***
*****
*
*  Name:          diodrvrMakeChain
*
*  Purpose:       given an alenlist, creates chained list for Prog DMA.
*
*  Returns:       NULL for error or address of chained list
*
*****/

```

```

static diodrvr_dmapage_t *
diodrvrMakeChain ( card_t *cp, alenlist_t addrList, int page_no )
{
    register          diodrvr_dmapage_t * dmaPg;
    register int      i, tot_words;
    size_t            p_size;
    alenaddr_t        p_addr;
    iopaddr_t         pa;

    printf("dioMakeChain: entering dioMakeChain\n");

    dmaPg = (diodrvr_dmapage_t *)kmem_alloc ((page_no+1) * sizeof(diodrvr_dmapage_t),
        KM_NOSLEEP | KM_PHYSCONTIG | KM_CACHEALIGN);

    if ( dmaPg == (diodrvr_dmapage_t *)NULL ) {
        cmn_err (CE_NOTE, "diodrvrMakeChain: Not enough mem for chained list");
        return( (diodrvr_dmapage_t *)NULL);
    }

    /* fill the chained list with address-size values */
    for ( i = 0; i < page_no; i++ ) {
        if ( alenlist_get(addrList, NULL, NBPP, &p_addr, &p_size, 0) !=
ALENLIST_SUCCESS ) {
            cmn_err (CE_WARN, "diodrvrMakeChain: Bad alenlist\n");
            return( (diodrvr_dmapage_t *)NULL);
        }

        pa = pciio_dmatrans_addr ( cp->conn, 0, kvtophys(&dmaPg[i+1]),

```

```

sizeof(diodrvr_dmaPage_t), PCIIO_DMA_DATA);
    tot_words      = (int)p_size/sizeof(uint_t);

    dmaPg[i].size   = p_size; /*tot_words;*/
    dmaPg[i].addr   = p_addr;
    dmaPg[i].DAR    = 0x1C;
    dmaPg[i].nextaddr = pa;

    #ifdef DEBUG
    printf("diodrvrMakeChain: page no: %d size: 0x%x addr: 0x%x next addr:
0x%x\n", i, dmaPg[i].size, dmaPg[i].addr, dmaPg[i].nextaddr);
    #endif

}
dmaPg[page_no].size      = 0;
dmaPg[page_no].nextaddr = 0;
dmaPg[page_no].DAR      = 0;
dmaPg[page_no].addr     = 0;

return ( dmaPg );
}

```

```

/*****
***          d i o d r v r S t a r t P r o g D m a          ***
****
*
*  Name:          diodrvrStartProgDma
*
*  Purpose:       Programs the board for Chained DMA and starts the Dma
*
*  Returns:       None.
*
*****/

```

static void

diodrvrStartProgDma (card_t *cp, iopaddr_t p_dmaPg, int tot_bytes, int rw)

```

{
    register caddr_t      dio_adr, mite_adr;
    register uint_t      adr_bits, enable_bits, dmacfg, dmacmd, dmabits;

    register uint_t      CHORbits, CHCRbits, MCRbits, DCRbits, LKCRbits, LKARbits,
LCR2bits;

    #ifdef DEBUG
    printf("diodrvrStartProgDma: entering diodrvrStartProgDma\n" );
    printf("diodrvrStartProgDma: number of bytes is 0x%x\n" , tot_bytes);
    #endif

    dio_adr = cp->dio_adr;
    mite_adr = cp->mite_adr;
    dmacfg = cp->dmacfg;
    dmacmd = cp->dmacmd;
    dmabits = cp->dmabits;
    cp->dmasize = tot_bytes; /* number of bytes to transfer by DMA */

    printf("diodrvrStarProgDma: MITE Dma addr: 0x%x\n" , DMA_BASE_ADDR);

    /* =====
    *      memory -> board
    * ===== */

    /* Build the CHOR bit pattern. */
    CHORbits = (unsigned int) (DMA_CHOR_DMARESET | DMA_CHOR_FRESET | DMA_CHOR_SET_SEND_TC);

    /* Build the CHCR bit pattern. */
    CHCRbits = (unsigned int) (DMA_CHCR_LINKLONG | DMA_CHCR_BURSTEN | DMA_CHCR_SET_DONE_IE
| DMA_CHCR_SET_DMA_IE );

    /* if (direction == INPUT)

```

```

        CHCRbits |= DMA_CHCR_DIR; */

/* Build the MCR bit pattern. */
MCRbits = DMA_MCR_RL64 | DMA_MCR_ASEQxP1 | DMA_MCR_PSIZEWORD | DMA_MCR_BLOCKEN;

/* Build the DCR bit pattern. */
DCRbits = DMA_DCR_RL64 | DMA_DCR_PSIZEWORD | DMA_DCR_PORTIO | MITE_DMA_AMDEVICE;

/* Set the drq request line to use */
switch (drqnum)
{
    case 0:
        DCRbits |= DMA_DCR_REQSDRQ0;
        break;
    case 1:
        DCRbits |= DMA_DCR_REQSDRQ1;
        break;
    case 2:
        DCRbits |= DMA_DCR_REQSDRQ2;
        break;
    case 3:
        DCRbits |= DMA_DCR_REQSDRQ3;
        break;
};

/* Build the LKCR bit pattern. */
LKCRbits = (uint_t) DMA_LKCR_RL64 | DMA_LKCR_ASEQUP | DMA_LKCR_PSIZEWORD;

/* Build the LKAR bit pattern (start address of chained list) */
LKARbits = (uint_t) p_dmaPg;

#ifdef DEBUG
    printf("diodrivrStartProgDma: DMA link chain phys addr 0x%x\n", LKARbits);
#endif

/* Read_Important_Registers(cp); */

printf("writing DMA registers\n");

/* Write the bit patterns to the registers. */
Out32(DMA_BASE_ADDR + DMA_CHOR, CHORbits);
Out32(DMA_BASE_ADDR + DMA_CHCR, CHCRbits);
Out32(DMA_BASE_ADDR + DMA_MCR, MCRbits);
Out32(DMA_BASE_ADDR + DMA_DCR, DCRbits);
Out32(DMA_BASE_ADDR + DMA_LKCR, LKCRbits);
Out32(DMA_BASE_ADDR + DMA_LKAR, LKARbits);

/* Read_Important_Registers(cp); */

/* set Transfer count */
Out32(dio_adr + Group_1_Transfer_Count, tot_bytes);

printf("arming the transfer\n");

/* arm the DMA transfer */
CHORbits = DMA_CHOR_START;
Out32(DMA_BASE_ADDR + DMA_CHOR, CHORbits);

Read_Important_Registers(cp);

printf("starting the transfer\n");

/* start the DMA transfer */
Out8(dio_adr + (Protocol_Register_1_Group_1 ^ 3), 0x0F);

/* Read_Important_Registers(cp); */
}

```

```

/*****
***          d i o d r v r S t a r t S i n g l e D m a          ***
****
*
* Name:          diodrvrStartSingleDma
*
* Purpose:       Programs the board for Single page DMA (read or write)
*
* Returns:       None.
*
*****/
static void
diodrvrStartSingleDma ( card_t *cp, alenaddr_t p_addr, size_t p_size, int rw )
{

    register caddr_t  dio_adr, mite_adr;
    register uint_t   adr_bits, enable_bits, dmacfg, dmacmd, dmabits, temp;
    register int      tot_words;

    register uint_t   CHORbits, CHCRbits, MCRbits, DCRbits, LKCRbits, LKARbits,
MARbits, TCRbits;

    dio_adr  = cp->dio_adr;
    mite_adr = cp->mite_adr;
    dmacfg   = cp->dmacfg;
    dmacmd   = cp->dmacmd;
    dmabits  = cp->dmabits;
    enable_bits = 0;
    cp->dmasize = p_size;

    printf("diodrvrStartSingleDma: starting single DMA\n");

    tot_words = (int)p_size/sizeof(uint_t);

    /* =====
    *      memory -> board
    * ===== */

    /* Build the CHOR bit pattern. */
    CHORbits = DMA_CHOR_DMARESET | DMA_CHOR_FRESET | DMA_CHOR_SET_SEND_TC;

    /* Build the CHCR bit pattern. */
    CHCRbits = DMA_CHCR_SET_DONE_IE | DMA_CHCR_SET_DMA_IE | DMA_CHCR_BURSTEN ;

    /* if (direction == INPUT)
       CHCRbits |= DMA_CHCR_DIR; */

    /* Build the MCR bit pattern. */
    MCRbits = DMA_MCR_RL64 | DMA_MCR_ASEQxP1 | DMA_MCR_PSIZEWORD | DMA_MCR_BLOCKEN;

    /* Build the DCR bit pattern. */
    DCRbits = DMA_DCR_RL64 | DMA_DCR_PORTIO | DMA_DCR_PSIZEWORD | DMA_DCR_AMDEVICE |
DMA_DCR_BLOCKEN;

    /* Set the drq request line to use */
    switch (drqnum)
    {
        case 0:
            DCRbits |= DMA_DCR_REQSDRQ0;
            break;
        case 1:
            DCRbits |= DMA_DCR_REQSDRQ1;
            break;
        case 2:
            DCRbits |= DMA_DCR_REQSDRQ2;
            break;
        case 3:
            DCRbits |= DMA_DCR_REQSDRQ3;
    }
}

```

```

        break;
    };

    /* DCRbits |= DMA_DCR_REQSINTMAX; */

    /* Build the LKCR bit pattern. */
    LKCRbits = (uint_t) DMA_LKCR_RL64 | DMA_LKCR_ASEQUP | DMA_LKCR_PSIZEWORD;

    /* Build the MAR, TCR amd LKAR bit patterns */
    MARbits = (uint_t) p_addr;
    TCRbits = (uint_t) p_size;
    LKARbits = (uint_t) 0;

    #ifdef DEBUG
        printf("diodrvrStartSingleDma: DMA buffer phys addr 0x%x size: 0x%x\n" ,
MARbits, TCRbits);
    #endif

    printf("writing DMA registers\n");

    /* Write the bit patterns to the MITE DMA registers. */
    Out32(DMA_BASE_ADDR + DMA_CHOR, CHORbits);
    Out32(DMA_BASE_ADDR + DMA_CHCR, CHCRbits);

    Out32(DMA_BASE_ADDR + DMA_MCR, MCRbits);

    Out32(DMA_BASE_ADDR + DMA_DCR, DCRbits);
    Out32(DMA_BASE_ADDR + DMA_LKCR, LKCRbits);

    Out32(DMA_BASE_ADDR + DMA_MAR, MARbits);
    Out32(DMA_BASE_ADDR + DMA_TCR, TCRbits);
    Out32(DMA_BASE_ADDR + DMA_LKAR, LKARbits);

    printf("arming the transfer\n");

    /* arm the DMA transfer */
    CHORbits = DMA_CHOR_START;
    Out32(DMA_BASE_ADDR + DMA_CHOR, CHORbits);

    /* set Transfer count */
    Out32(dio_adr + Group_1_Transfer_Count, p_size);

    printf("starting the transfer\n");\

    Read_Important_Registers(cp);

    /* start the DMA transfer */
    Out8(dio_adr + (Protocol_Register_1_Group_1^3), 0x0F);
}

```

```

/*****
***          d i o d r v r A l e n l i s t S i z e          ***
*****/
*
* Name:          cocoAlenlistSize
*
* Purpose:      Returns number of pairs in a given alenlist.
*
* Returns:      Number of address/size entries
*
*****/

```

```

static int
diodrvrAlenlistSize ( alenlist_t al )
{
    register int    count;
    size_t         size;

```

```

, alenaddr_t      addr;

printf("diodrvrAlenlistSize\n");

alenlist_cursor_init ( al, NULL, NULL );
count = 0;
for ( ;; ) {
    if ( alenlist_get(al, NULL, NBPP, &addr, &size, 0) !=
        ALENLIST_SUCCESS ) {
        break;
    }
    count++;
}
alenlist_cursor_init ( al, NULL, NULL );

return (count);
}

/*****
***          d i o d r v r T i m e O u t          ***
****
*
* Name:          cocoTimeout
*
* Purpose:       We timedout waiting for a read/write interrupt.
*
* Returns:       None.
*
*****/
static void
diodrvrTimeout ( card_t *cp )
{
    register uint_t  intcsr;
    register int     s;

    /* someone has the lock ? ignore the timeout */
    if ( ( s = DIODRVR_TRYLOCK(&cp->diodrvr_mlock) ) == 0 )
        return;

    cmn_err (CE_NOTE, "diodrvrTimeout: Read/Write Timed out");

    alenlist_done ( cp->addrList );
    cp->addrList = 0;

    alenlist_done ( cp->alenList );
    cp->alenList = 0;

    /* free our DMA maps */
    pciio_dmamap_free(cp->buffer_map);
    pciio_dmamap_free(cp->link_map);

    cp->iostat   = IO_TIME;

    bioerror ( cp->bp, ETIME);
    biodone (cp->bp);
    DIODRVR_UNLOCK(&cp->diodrvr_mlock, s);
}

/*****
***          d i o d r v r _ r e s e t          ***
****
*****/
void diodrvr_reset(card_t *cp)
{
    #ifdef DEBUG
        printf("diodrvr_reset command issued.\n");
    #endif
}

```

```

/* stop all transfers */
Out8(cp->dio_adr + (Protocol_Register_1_Group_1^3), 0x0);
Out8(cp->dio_adr + (Protocol_Register_1_Group_2^3), 0x0);

/* Flush FIFO Buffer and clear flags */
Out8(cp->dio_adr + (Group_1_First_Clear^3), 0xFF); /* bits 4,5, 7 */
Out8(cp->dio_adr + (Group_2_First_Clear^3), 0xFF);

Out8(cp->dio_adr + (Group_1_Second_Clear^3), 0x03);
Out8(cp->dio_adr + (Group_2_Second_Clear^3), 0x03);

/* clear groups */
Out8(cp->dio_adr + (Data_Path_Group_1^3), 0x00);
Out8(cp->dio_adr + (Data_Path_Group_2^3), 0x00);

/* write zero to the output ports */
Out32(cp->dio_adr + Port_A_Output, 0x00);
}

/*****
***          d i o d r v r _ b u r s t _ c l k o u t
***
*****/
void diodrivr_burst_clkout(card_t *cp, int *arg)
{
    char width;

#ifdef DEBUG
    printf("Executing diodrivr_burst_protocol_setup\n");
#endif

    /* Configure the pins on ports ABCD simultaneously */
    Out32(cp->dio_adr + Port_A_Pin_Directions, 0x00);
    Out32(cp->dio_adr + Port_A_Pin_Mask, 0x00);
    Out32(cp->dio_adr + Port_A_Pin_Directions, 0xFFFFFFFF);

    /*** Reset ***/
    Out8(cp->dio_adr + (Protocol_Register_1_Group_1^3), 0x00);

    /*** Configure data paths and ports ***/
    Out8(cp->dio_adr + (Data_Path_Group_1^3), *arg);

    width = (((*arg) & 0x8)>>3) + (((*arg) & 0x4)>>2) + (((*arg) & 0x2)>>1) + ((*arg) &
0x1);
    switch (width)
    {
        case 1:
            width = 2; /* 8-bit transfers */
            break;
        case 2:
            width = 3; /* 16-bit transfers */
            break;
        case 3:
        case 4:
            width = 0; /* 32-bit transfers */
            break;
    }

    width = (*arg & 0x80) >> 2 | width; /* this sets bit 5 if transfer is output */

#ifdef DEBUG
    printf("protocol group: 0x%x\n", *arg); /* should read 0x8f for 32-bit output
*/
    printf("protocol width: 0x%x\n", width); /* should read 0x20 for 32-bit output
*/
#endif
}

```

```

    /** Configure transfer width and RequireRLevel */
    Out8(cp->dio_adr + (Transfer_Size_Control_Group_1^3), width);

    /** Set protocol to burst mode */
    Out8(cp->dio_adr + (Protocol_Register_1_Group_1^3), 0x00);
    Out8(cp->dio_adr + (Protocol_Register_2_Group_1^3), 0x60);
    Out8(cp->dio_adr + (Protocol_Register_3_Group_1^3), 0x00);
    Out8(cp->dio_adr + (Protocol_Register_4_Group_1^3), 0x08);
    Out8(cp->dio_adr + (Protocol_Register_5_Group_1^3), 0x04);
    Out8(cp->dio_adr + (Protocol_Register_6_Group_1^3), 0x00);
    Out8(cp->dio_adr + (Protocol_Register_7_Group_1^3), 0x60);
    Out8(cp->dio_adr + (Protocol_Register_8_Group_1^3), 0x01);

    Out8(cp->dio_adr + (Clock_Speed_Group_1^3), 0x00);
    Out8(cp->dio_adr + (FIFO_Control_Group_1^3), 0x01);
}

/*****
***      diodrivr_burst_clk_in
***
*****/
void diodrivr_burst_clk_in(card_t *cp, int *arg)
{
    char width;

#ifdef DEBUG
    printf("Executing diodrivr_burst_protocol_setup\n");
#endif

    /* Configure the pins on ports ABCD simultaneously */
    Out32(cp->dio_adr + Port_A_Pin_Directions, 0x00);
    Out32(cp->dio_adr + Port_A_Pin_Mask, 0x00);
    Out32(cp->dio_adr + Port_A_Pin_Directions, 0xFFFFFFFF);

    /** Reset */
    Out8(cp->dio_adr + (Protocol_Register_1_Group_1^3), 0x00);

    /** Configure data paths and ports */
    Out8(cp->dio_adr + (Data_Path_Group_1^3), *arg);

    width = (((*arg) & 0x8)>>3) + (((*arg) & 0x4)>>2) + (((*arg) & 0x2)>>1) + ((*arg) &
0x1);
    switch (width)
    {
        case 1:
            width = 2; /* 8-bit transfers */
            break;
        case 2:
            width = 3; /* 16-bit transfers */
            break;
        case 3:
        case 4:
            width = 0; /* 32-bit transfers */
            break;
    }

    width = (*arg & 0x80) >> 2 | width; /* this sets bit 5 if transfer is output */

#ifdef DEBUG
    printf("protocol group: 0x%x\n", *arg); /* should read 0x8f for 32-bit output
*/
    printf("protocol width: 0x%x\n", width); /* should read 0x20 for 32-bit output
*/
#endif

    /** Configure transfer width and RequireRLevel */
    Out8(cp->dio_adr + (Transfer_Size_Control_Group_1^3), width);

```

```

    /** Set protocol to burst mode */
    Out8(cp->dio_adr + (Protocol_Register_1_Group_1^3), 0x00);
    Out8(cp->dio_adr + (Protocol_Register_2_Group_1^3), 0x10);
    Out8(cp->dio_adr + (Protocol_Register_3_Group_1^3), 0x00);
    Out8(cp->dio_adr + (Protocol_Register_4_Group_1^3), 0x20);
    Out8(cp->dio_adr + (Protocol_Register_5_Group_1^3), 0x04);
    Out8(cp->dio_adr + (Protocol_Register_6_Group_1^3), 0x00);
    Out8(cp->dio_adr + (Protocol_Register_7_Group_1^3), 0x60);
    Out8(cp->dio_adr + (Protocol_Register_8_Group_1^3), 0x01);

    Out8(cp->dio_adr + (Clock_Speed_Group_1^3), 0x00);
    Out8(cp->dio_adr + (FIFO_Control_Group_1^3), 0x01);
}

/*****
***          d i o d r v r _ d m a _ g r o u p 1
***
*****/
void diodrivr_dma_group1(card_t *cp, int *arg)
{
    #ifdef DEBUG
        printf("programming group1 Dma\n");
    #endif

    /* Specify DMA Channel to use (5=both channels) */
    Out8(cp->dio_adr + (DMA_Line_Control_Group_1^3), *arg);
}

/*****
***          d i o d r v r _ i n t r _ c o u n t e x p
***
*****/
void diodrivr_int_countexp(card_t *cp )
{
    /* Program the interrupt to occur on CountExpired */
    Out8(cp->dio_adr + (Interrupt_Enable_Group_1^3), 0x02); /* this enables bit 1 */

    /* Enable the interrupt line for normal operation */
    Out8(cp->dio_adr + (Interrupt_Control^3), 0x08); /* this enables bit 3 */
}

/*****
***          d i o d r v r _ r u n
***
*****/
void diodrivr_run(card_t *cp )
{
    /* start the transfer in numbered mode */
    Out8(cp->dio_adr + (Protocol_Register_1_Group_1^3), 0x0F);
}

/*****
***          d i o d r v r _ s t o p
***
*****/
void diodrivr_stop(card_t *cp )
{
    /* start the transfer in numbered mode */
    Out8(cp->dio_adr + (Protocol_Register_1_Group_1^3), 0x0);
}

/*****
*          R e a d _ I m p o r t a n t _ R e g i s t e r s
*
*****/

```

```

void Read_Important_Registers (card_t *cp)
{
    uint_t MARcontents, TCRcontents, LKARcontents;
    uint_t CHOR, CHCR, MCR, DCR, LKCR;

    #ifdef DEBUG
        printf("Reading important addresses\n");

    CHOR = Inp32(DMA_BASE_ADDR + DMA_CHOR);
    CHCR = Inp32(DMA_BASE_ADDR + DMA_CHCR);
    MCR = Inp32(DMA_BASE_ADDR + DMA_MCR);
    DCR = Inp32(DMA_BASE_ADDR + DMA_DCR);
    LKCR = Inp32(DMA_BASE_ADDR + DMA_LKCR);
    TCRcontents = Inp32(DMA_BASE_ADDR + DMA_TCR);
    MARcontents = Inp32(DMA_BASE_ADDR + DMA_MAR);
    LKARcontents = Inp32(DMA_BASE_ADDR + DMA_LKAR);

/*
    printf("CHOR contents = 0x%x\n", CHOR);
    printf("CHCR contents = 0x%x\n", CHCR);
    printf("MCR contents = 0x%x\n", MCR);
    printf("DCR contents = 0x%x\n", DCR);
    printf("LKCR contents = 0x%x\n", LKCR);
*/

    printf("TCR contents = 0x%x\n", TCRcontents);
    printf("MAR contents = 0x%x\n", MARcontents);
    printf("LKAR contents = 0x%x\n", LKARcontents);
    #endif
}

#ifdef DEBUGTIME
/*****
***                               d i o d r v r R e p o r t T i m e                               ***
****
****                               ****
*
*   Name:           diodrvrReportTime
*
*   Purpose:        Displays start, intr and end time of Dma
*
*   Returns:        None.
*
*****/
static void
diodrvrReportTime ( caddr_t title, card_t *cp, int final )
{
    register struct timespec *tv;
    struct timespec dtv;
    diodrvr_timeval_t st;
    diodrvr_timeval_t et;
    diodrvr_timeval_t dt;

/* report start and interrupt of DMA */
if ( final == 0 ) {
    diodrvrDiffTime ( &cp->start_time, &cp->intr_time, &dtv );
    diodrvrConvTime ( &dtv, &dt );
    diodrvrConvTime ( &cp->start_time, &st );
    diodrvrConvTime ( &cp->intr_time, &et );

    printf ("\n%s: %s DMA, %d Bytes\n",
        title, cp->dmatype == DMA_CHAIN ? "Chain":"Single", cp->dmasize );

    printf ("Start:\t%8dmsec %8dusec %8dnsec\n",
        st.diodrvr_msec, st.diodrvr_usec, st.diodrvr_nsec);
    printf ("Intrp:\t%8dmsec %8dusec %8dnsec\n",
        et.diodrvr_msec, et.diodrvr_usec, et.diodrvr_nsec);
    printf ("Diff:\t%8dmsec %8dusec %8dnsec\n",
        dt.diodrvr_msec, dt.diodrvr_usec, dt.diodrvr_nsec );
}
}

```

```
return;
```

```
    }  
  
    /* report the time difference of call came in and return time */  
    diodrivrDiffTime ( &cp->call_time, &cp->ret_time, &dtv );  
    diodrivrConvTime ( &dtv, &dt );  
    diodrivrConvTime ( &cp->call_time, &st );  
    diodrivrConvTime ( &cp->ret_time, &et );  
  
    printf ("\n%s: final Call analysis\n", title );  
    printf ("Call:\t%8dmsec %8dusec %8dnsec\n",  
           st.diodrivr_msec, st.diodrivr_usec, st.diodrivr_nsec );  
    printf ("Ret:\t%8dmsec %8dusec %8dnsec\n",  
           et.diodrivr_msec, et.diodrivr_usec, et.diodrivr_nsec );  
    printf ("Diff:\t%8dmsec %8dusec %8dnsec\n",  
           dt.diodrivr_msec, dt.diodrivr_usec, dt.diodrivr_nsec );  
  
    }  
#endif
```

```
/*  
***  
***** d i o d r v r U s e r T i m e *****  
*****  
*  
* Name: diodrivrUserTime  
*  
* Purpose: Returns timing to user at end.  
*  
* Returns: None.  
*  
*****/  
static void
```

```
diodrivrUserTime ( card_t *cp, int *arg )  
{  
  
    struct timespec dtv;  
    diodrivr_timeval_t dt;  
  
    /* report the time difference of call came in and return time */  
    diodrivrDiffTime ( &cp->call_time, &cp->ret_time, &dtv );  
    diodrivrConvTime ( &dtv, &dt );  
  
    *arg = dt.diodrivr_msec* 1000000 + dt.diodrivr_usec * 1000 + dt.diodrivr_nsec;  
  
}
```

```
/*  
***  
***** d i o d r v r D i f f T i m e *****  
*****  
*  
* Name: diodrivrDiffTime  
*  
* Purpose: Given two timespec struct, it calculates the difference  
*  
* Returns: None.  
*  
*****/  
static void
```

```
diodrivrDiffTime ( struct timespec *st, struct timespec *et, struct timespec *dt )  
{  
  
    register long s_sec, e_sec;  
    register long s_totn, e_totn, diff_n;  
  
    s_sec = st->tv_sec;  
    s_totn = (s_sec * 1000000000L) + st->tv_nsec;
```

```

e_sec    = et->tv_sec;
e_totn   = (e_sec * 1000000000L) + et->tv_nsec;

diff_n   = e_totn - s_totn;

dt->tv_sec = 0;
dt->tv_nsec = diff_n;

if ( diff_n > 1000000000L ) {
    dt->tv_sec = diff_n / 1000000000L;
    dt->tv_nsec = diff_n % 1000000000L;
}
}

```

```

/*****
***                               d i o d r v r C o n v T i m e                               ***
****
*
* Name:          diodrvrConvTime
*
* Purpose:       Converts a timespec_t to diodrvr_timeval_t
*
* Returns:       None.
*
*****/

```

```

static void
diodrvrConvTime ( struct timespec *ts, diodrvr_timeval_t *ct )
{
    long    totn, sec, msec, usec, nsec;

    totn = (ts->tv_sec * 1000000000L) + ts->tv_nsec;
    sec = msec = usec = nsec = 0;

    /* round up nano to micro */
    if ( totn > 1000L ) {
        usec = totn / 1000L;
        nsec = totn % 1000L;
    }

    /* round up micro to mili */
    if ( usec > 1000L ) {
        msec = usec / 1000L;
        usec = usec % 1000L;
    }

    /* round up mili to seconds */
    if ( msec > 1000L ) {
        sec = msec / 1000L;
        msec = msec % 1000L;
    }

    ct->diodrvr_sec = sec;
    ct->diodrvr_msec = msec;
    ct->diodrvr_usec = usec;
    ct->diodrvr_nsec = nsec;
}
}

```

E. Framebuffer schematics

The following pages contain the electronic schematics of the MVD framebuffer electronics.

SLM INTERFACE MAIN BOARD BLOCK DIAGRAM

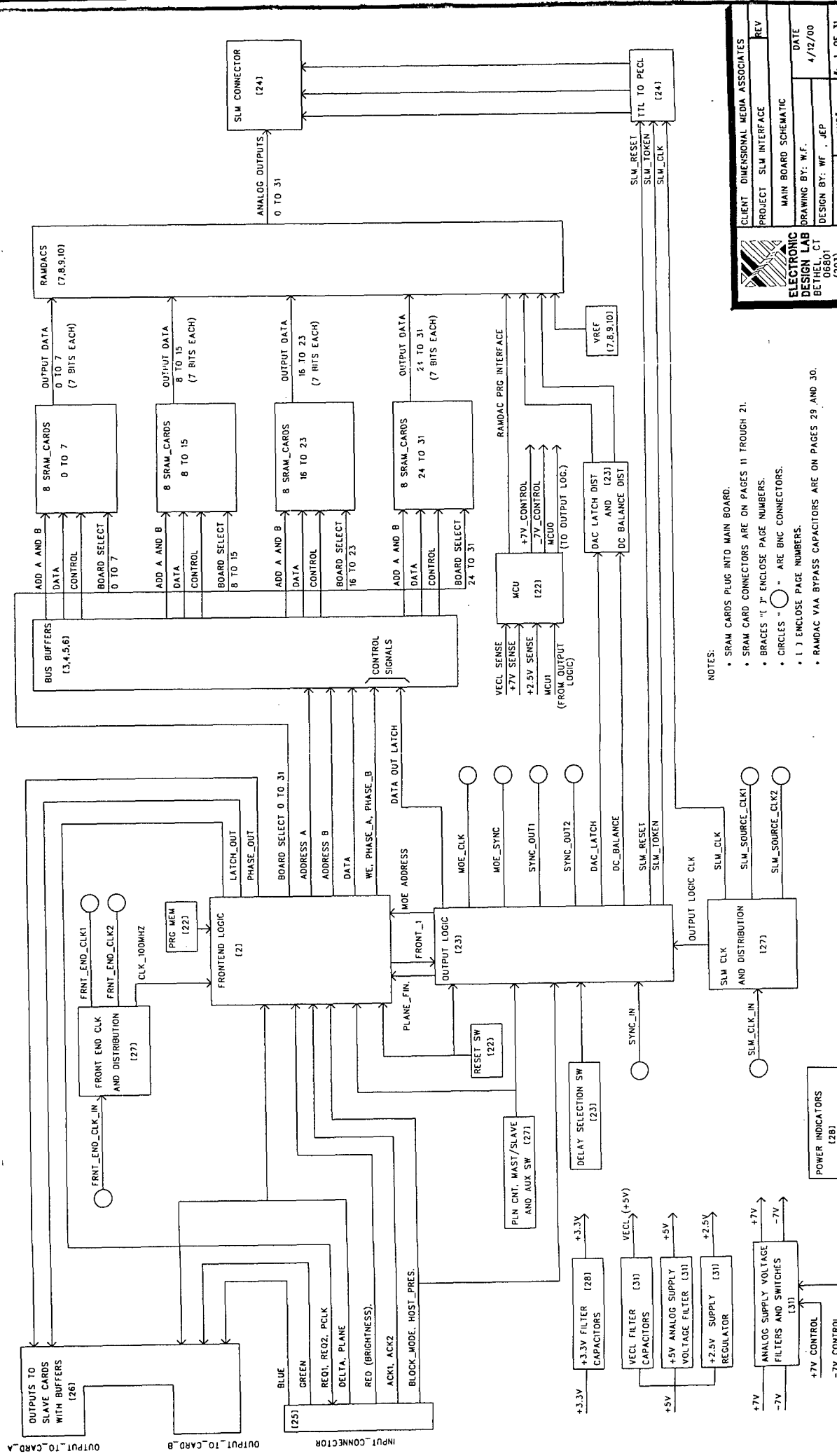

CLIENT: DIMENSIONAL MEDIA ASSOCIATES	
PROJECT: SLM INTERFACE	REV: _____
MAIN BOARD SCHEMATIC	
DESIGN BY: W.F. JEP	DATE: 4/12/00
JOB: 667	DRAWING: _____
ELECTRONIC DESIGN LAB BETHEL, CT 06801 780-0500	
F: 1 OF 31	

- NOTES:
- SRAM CARDS PLUG INTO MAIN BOARD.
 - SRAM CARD CONNECTORS ARE ON PAGES 11 THROUGH 21.
 - BRACES {} ENCLOSE PAGE NUMBERS.
 - CIRCLES ○ ARE BNC CONNECTORS.
 - I J ENCLOSE PAGE NUMBERS.
 - RAMDAC VAA BYPASS CAPACITORS ARE ON PAGES 29 AND 30.

FRONT-END LOGIC

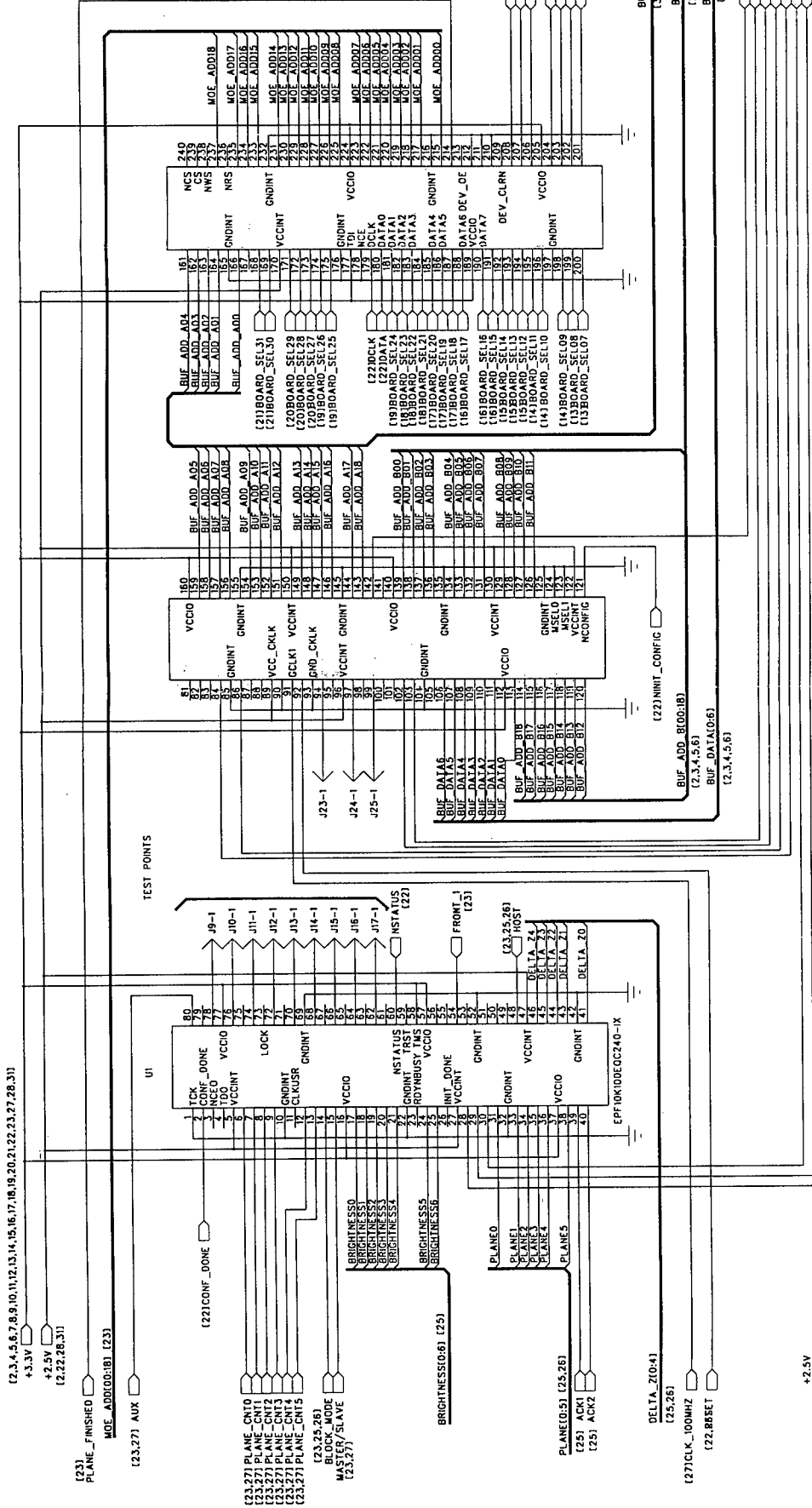

ELECTRONIC DESIGN LAB
 BETHEL, CT
 06801
 786-3500

CLIENT: DIMENSIONAL MEDIA ASSOCIATES
 PROJECT: SLM INTERFACE
 MAIN BOARD SCHEMATIC
 DRAWING BY: W.F.
 DESIGN BY: W.F. / SEP
 DATE: 4/12/00
 JOB: 667 DRAWING: # 2 OF 31

B

BUS BUFFER GROUP 0

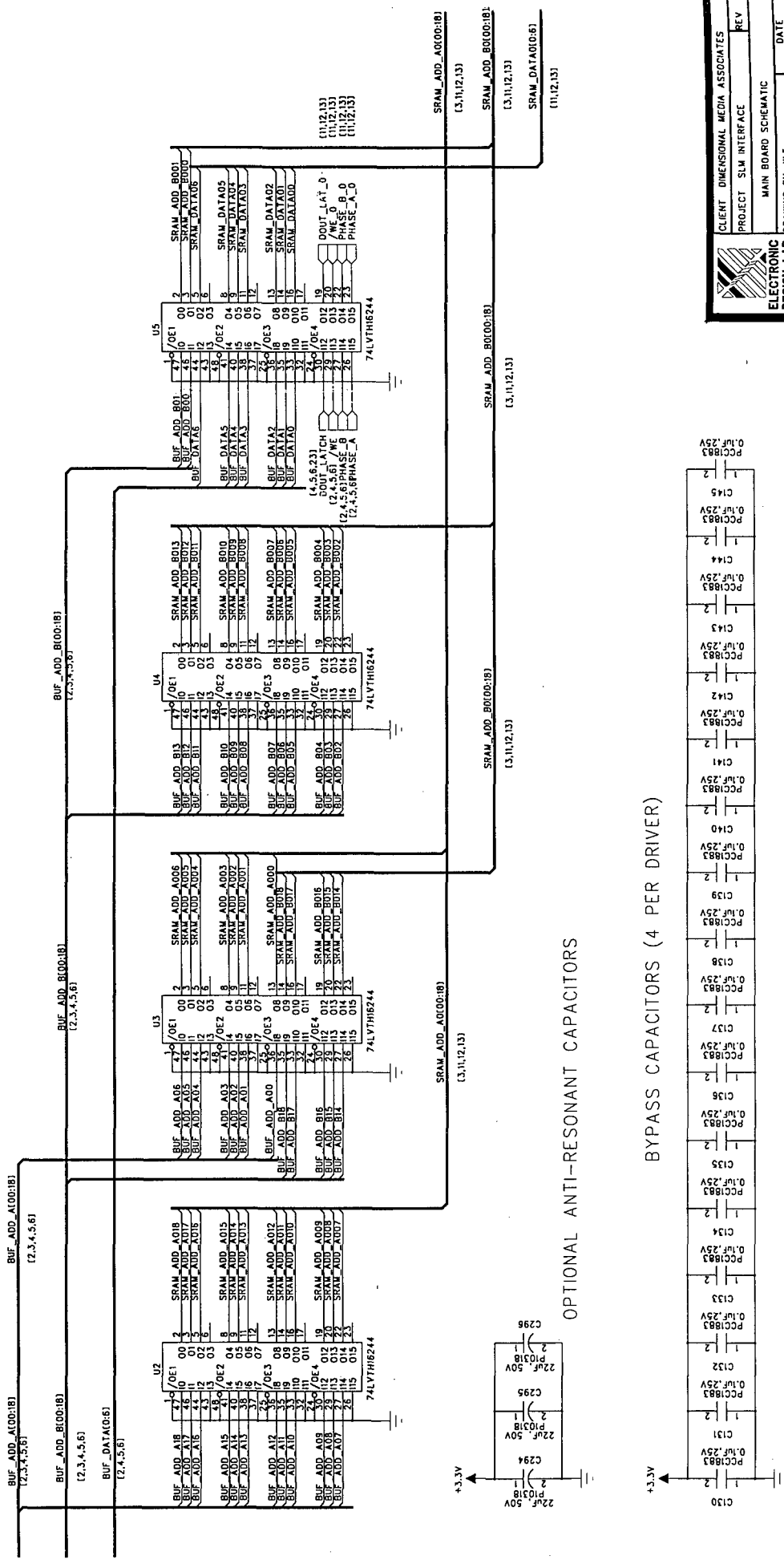

OPTIONAL ANTI-RESONANT CAPACITORS

BYPASS CAPACITORS (4 PER DRIVER)

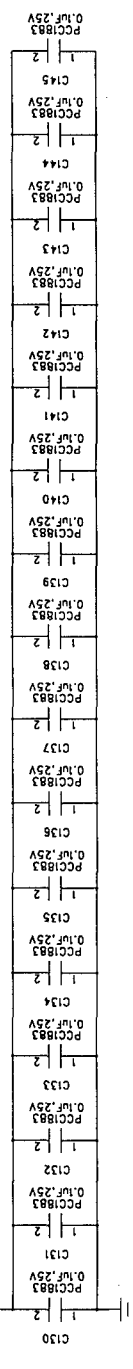

ELECTRONIC DESIGN LAB
 BETHEL, CT
 06801
 795-8350

CLIENT: DIMENSIONAL MEDIA ASSOCIATES
 PROJECT: SLIM INTERFACE
 MAIN BOARD SCHEMATIC
 DRAWING BY: W.F.
 DESIGN BY: WF
 DATE: 4/12/00
 JOB: 667
 DRAWING: F. 3 OF 31

BUS BUFFER GROUP 1

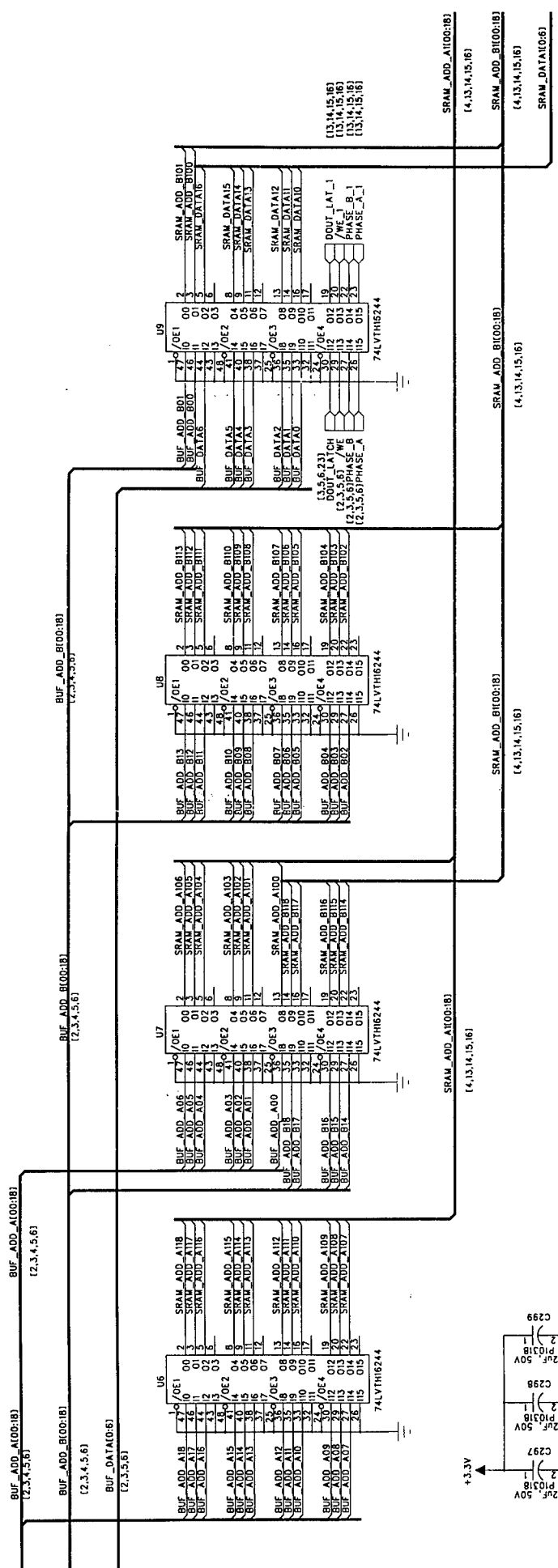

OPTIONAL ANTI-RESONANT CAPACITORS

BYPASS CAPACITORS (4 PER DRIVER)

CLIENT DIMENSIONAL MEDIA ASSOCIATES
 PROJECT SLM INTERFACE
 MAIN BOARD SCHEMATIC
 DRAWING BY: WF.
 DATE: 4/12/00
 DESIGN BY: WF . JEP
 JOB: 667 [DRAWING] | 4 OF 31

GROUP 0 RAMDACS

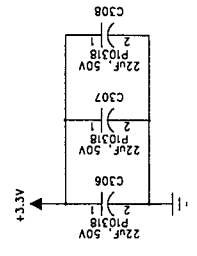
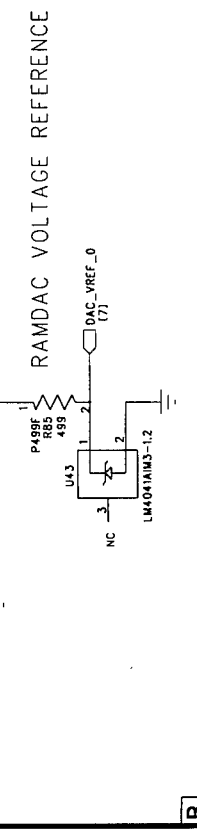
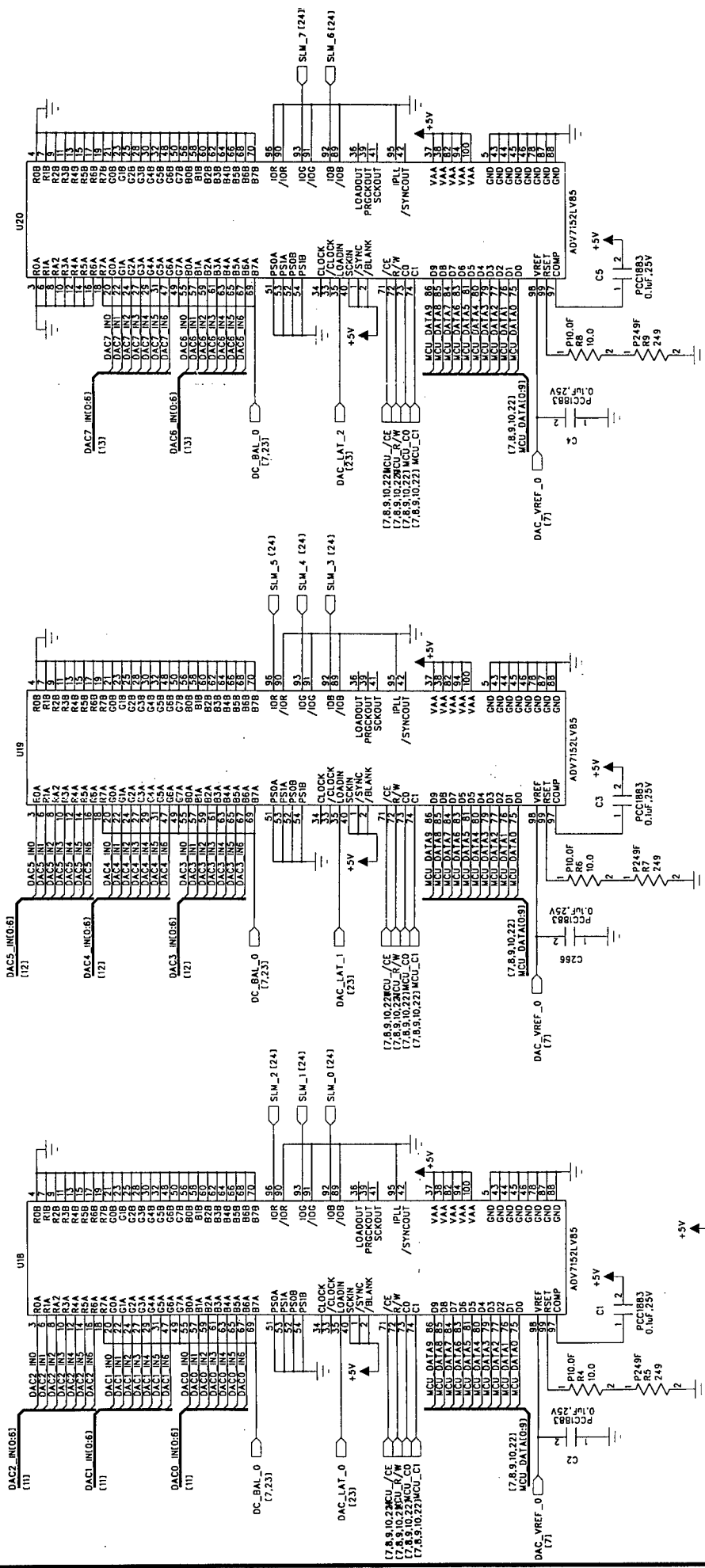

ELECTRONIC DESIGN LAB
 BE UNIT 0660 CT
 (203) 790-0500

CLIENT: DIMENSIONAL MEDIA ASSOCIATES
 PROJECT: SLM INTERFACE
 MAIN BOARD SCHEMATIC
 DRAWING BY: W.F.
 DESIGN BY: W.F. JEP
 JOB: 667 DRAWING # 7 OF 31

DATE: 4/12/00

GROUP 2 RAMDACs

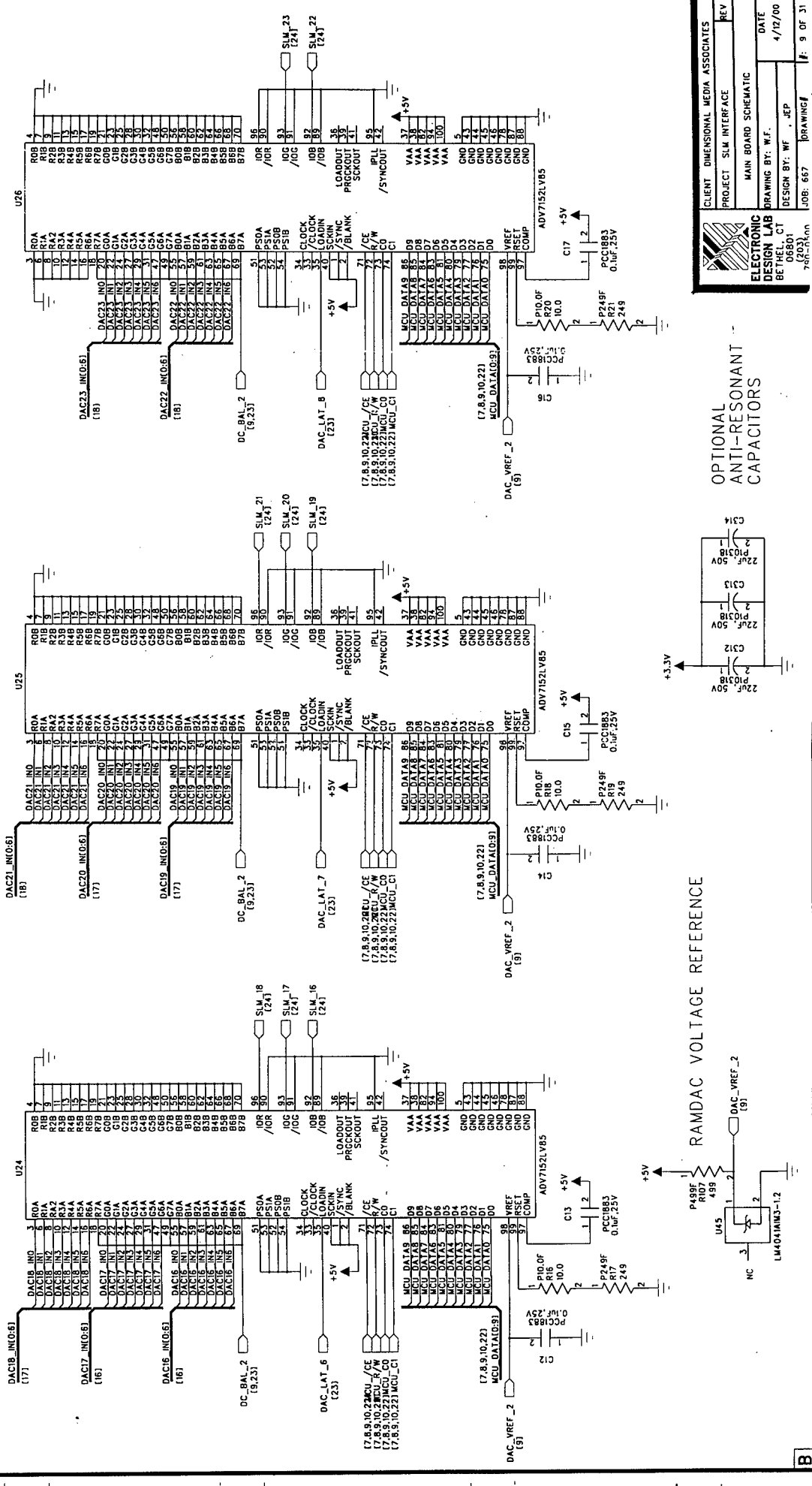

OPTIONAL ANTI-RESONANT CAPACITORS

C34
225P
P10318
50V

C31
225P
P10318
50V

C32
225P
P10318
50V

C34
225P
P10318
50V

C31
225P
P10318
50V

C32
225P
P10318
50V

RAMDAC VOLTAGE REFERENCE

P499F
R107
499

U45
LM4011M3-1.2

NC

DAC_VREF_2 (81)

CLIENT: DIMENSIONAL MEDIA ASSOCIATES
 PROJECT: SLM INTERFACE
 REV: []
 MAIN BOARD SCHEMATIC
 DATE: 4/12/00
 DESIGN BY: W.F. JEP
 06801
 (203)
 780-7600
 DRAWING: []

OPTIONAL ANTI-RESONANT CAPACITORS

RAMDAC VOLTAGE REFERENCE

OPTIONAL ANTI-RESONANT CAPACITORS

OPTIONAL ANTI-RESONANT CAPACITORS

OPTIONAL ANTI-RESONANT CAPACITORS

GROUP 3 RAMDACs

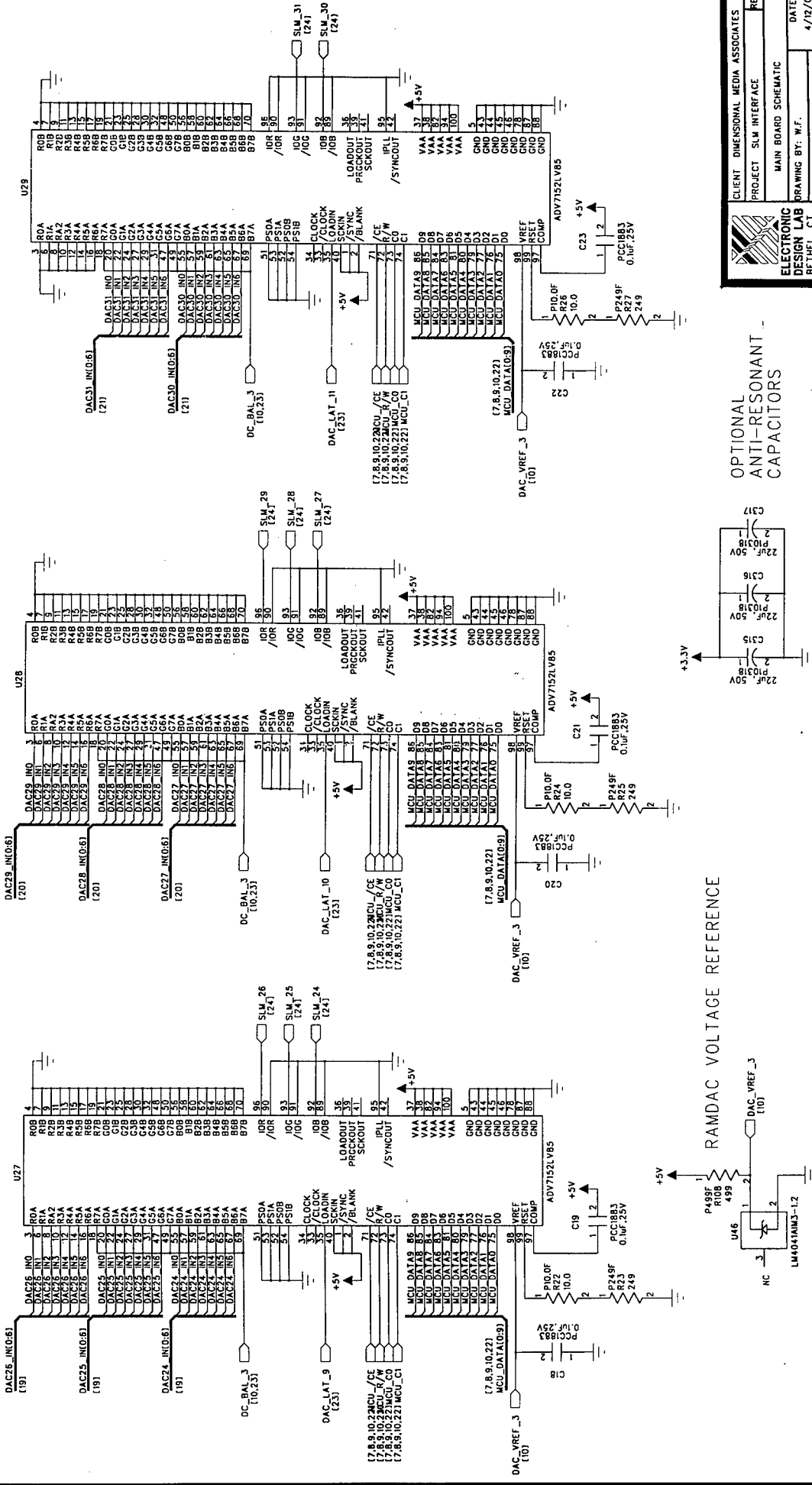

OPTIONAL ANTI-RESONANT CAPACITORS

RAMDAC VOLTAGE REFERENCE

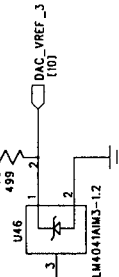

ELECTRONIC DESIGN LAB
 BETHEL, CT 06801
 (203) 760-6400

CLIENT	DIMENSIONAL MEDIA ASSOCIATES
PROJECT	SLM INTERFACE
REV	
DATE	4/12/00
DRAWING BY:	W.F.
DESIGN BY:	W.F.
JOB:	667
DRAWING:	
SCALE:	1/10 OF 31

B

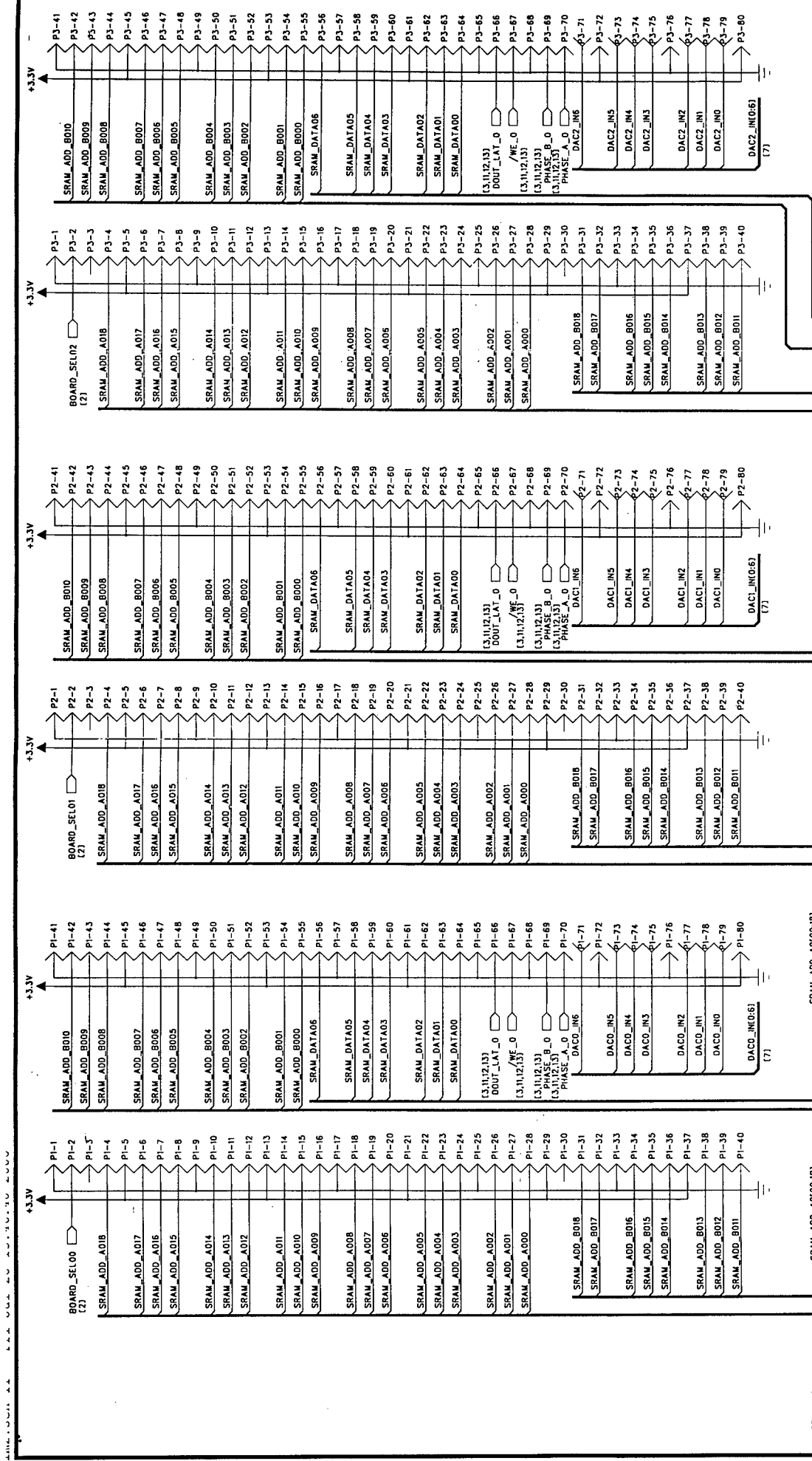

SRAM_ADD_A000(0:8)	SRAM_ADD_A000(8)	SRAM_ADD_A000(16)	SRAM_ADD_A000(16)	SRAM_ADD_B000(0:8)	SRAM_ADD_B000(8)	SRAM_ADD_B000(16)	SRAM_ADD_B000(16)
SRAM_ADD_B000(0:8)	SRAM_ADD_B000(8)	SRAM_ADD_B000(16)	SRAM_ADD_B000(16)	SRAM_ADD_A000(0:8)	SRAM_ADD_A000(8)	SRAM_ADD_A000(16)	SRAM_ADD_A000(16)
SRAM_ADD_A000(0:8)	SRAM_ADD_A000(8)	SRAM_ADD_A000(16)	SRAM_ADD_A000(16)	SRAM_ADD_B000(0:8)	SRAM_ADD_B000(8)	SRAM_ADD_B000(16)	SRAM_ADD_B000(16)
SRAM_ADD_B000(0:8)	SRAM_ADD_B000(8)	SRAM_ADD_B000(16)	SRAM_ADD_B000(16)	SRAM_ADD_A000(0:8)	SRAM_ADD_A000(8)	SRAM_ADD_A000(16)	SRAM_ADD_A000(16)

CLIENT: DIMENSIONAL MEDIA ASSOCIATES
 PROJECT: SLM INTERFACE
 MAIN BOARD SCHEMATIC
 DATE: 4/12/00
 DESIGN BY: WF . JEP
 JOB: 657 [DRAWING]
 760-0100

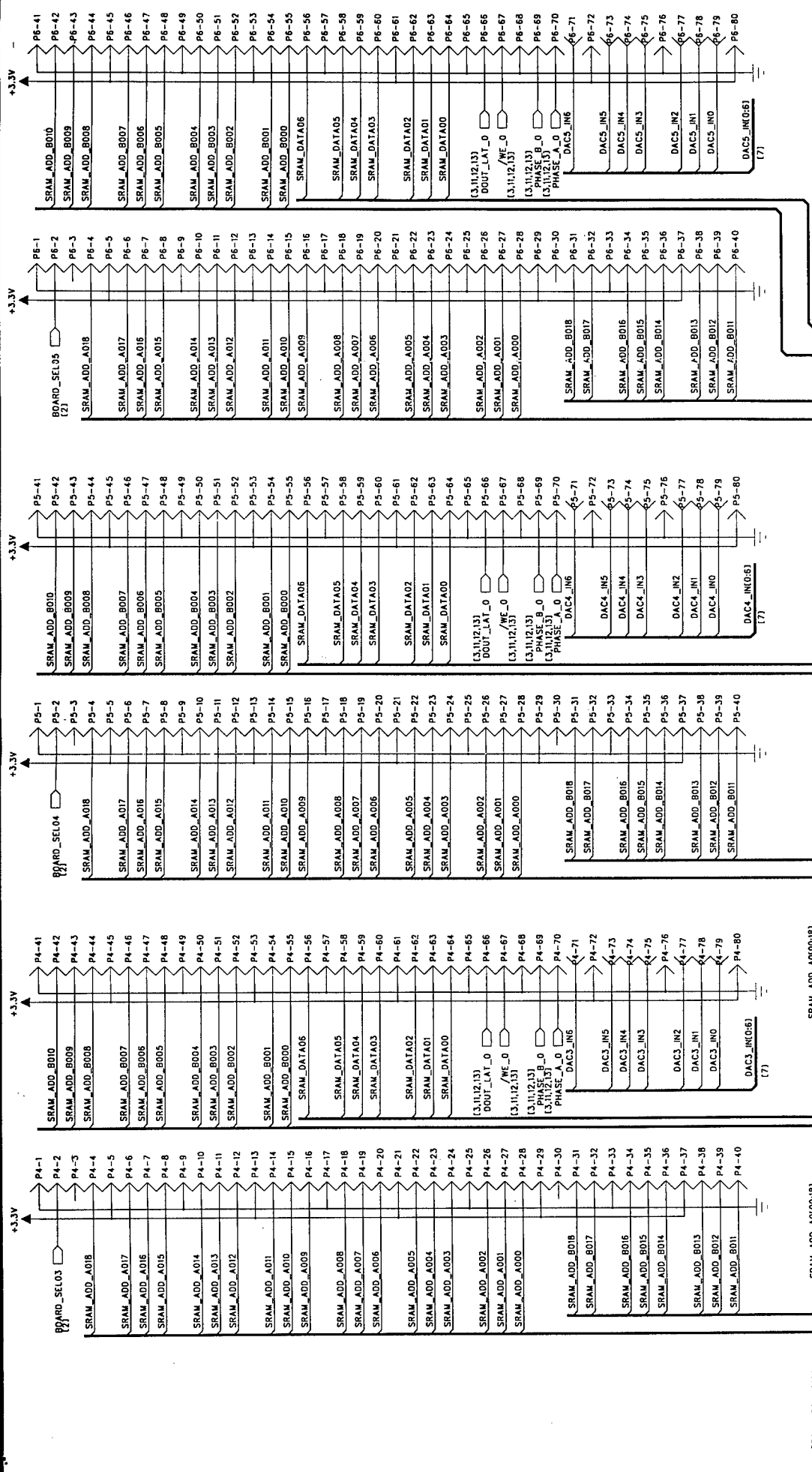

CLIENT	PROJECT	REV	DATE
DIMENSIONAL MEDIA ASSOCIATES	SLM INTERFACE		4/12/00
MAIN BOARD SCHEMATIC			
DRAWING BY: W.F.			
DESIGN BY: W.F. JEP			
JOB: 667 DRAWING: F. 12 OF 31			

ELECTRONIC DESIGN LAB
 BETHEL, CT
 (203) 366-0801
 FAX: (203) 366-0800

B

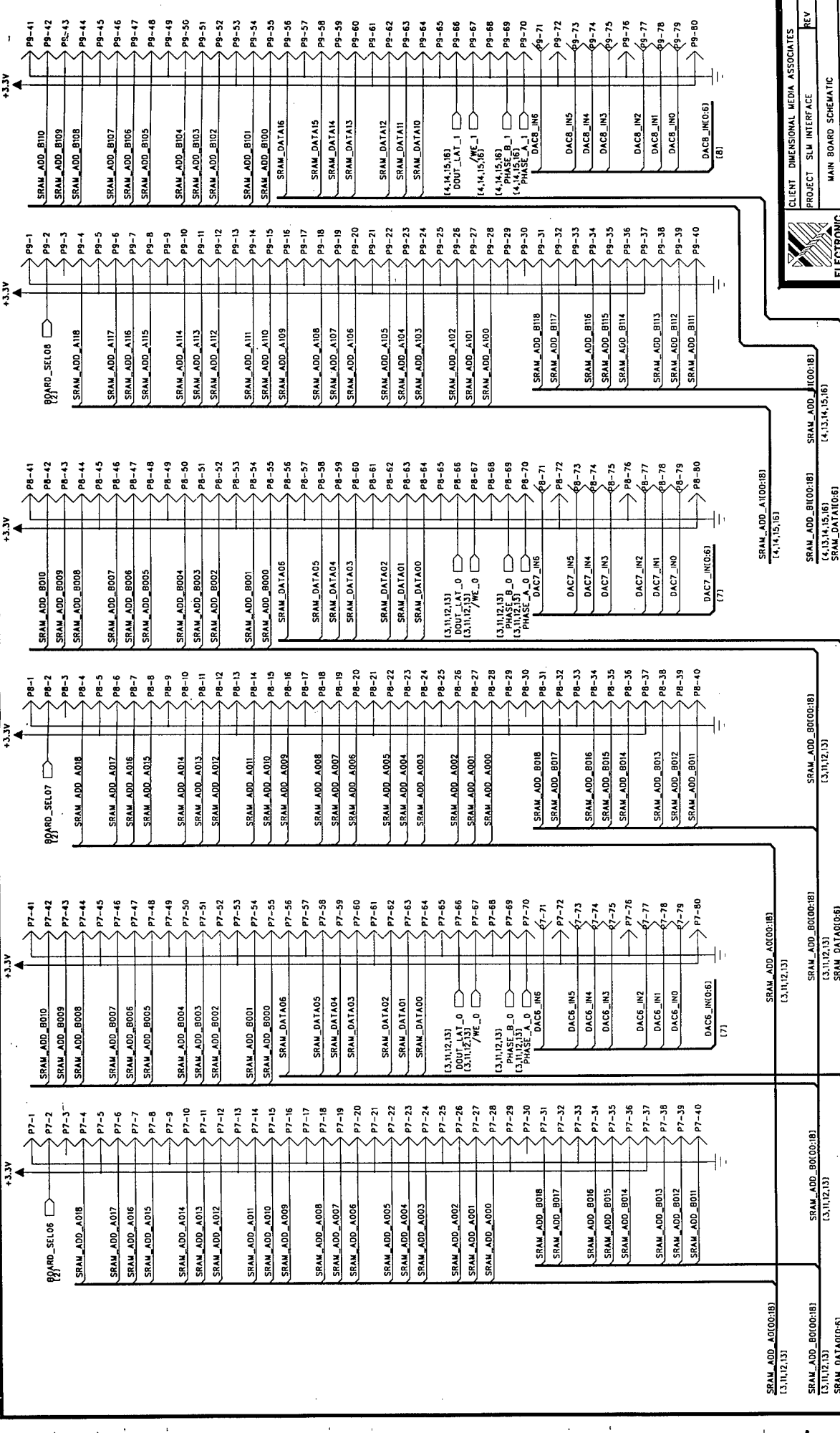

CLIENT	DIMENSIONAL MEDIA ASSOCIATES
PROJECT	SLM INTERFACE
REV	
DATE	4/12/00
MAIN BOARD SCHEMATIC	
DRAWING BY:	WF . JEP
DESIGN BY:	068001
APP: 657	DRAWING: 1
DATE:	4/12/00

SRAM_ADD_A(000:18)	SRAM_ADD_B(000:18)	SRAM_ADD_C(000:18)	SRAM_ADD_D(000:18)
(3,11,12,13)	(3,11,12,13)	(3,11,12,13)	(3,11,12,13)
SRAM_ADD_A(100:18)	SRAM_ADD_B(100:18)	SRAM_ADD_C(100:18)	SRAM_ADD_D(100:18)
(4,14,15,16)	(4,14,15,16)	(4,14,15,16)	(4,14,15,16)
SRAM_ADD_A(110:18)	SRAM_ADD_B(110:18)	SRAM_ADD_C(110:18)	SRAM_ADD_D(110:18)
(4,14,15,16)	(4,14,15,16)	(4,14,15,16)	(4,14,15,16)
SRAM_ADD_A(118:18)	SRAM_ADD_B(118:18)	SRAM_ADD_C(118:18)	SRAM_ADD_D(118:18)
(4,14,15,16)	(4,14,15,16)	(4,14,15,16)	(4,14,15,16)

ELECTRONIC DESIGN LAB
BE THEL CT
2003
7400 RENA

BUS BUFFER GROUP 3

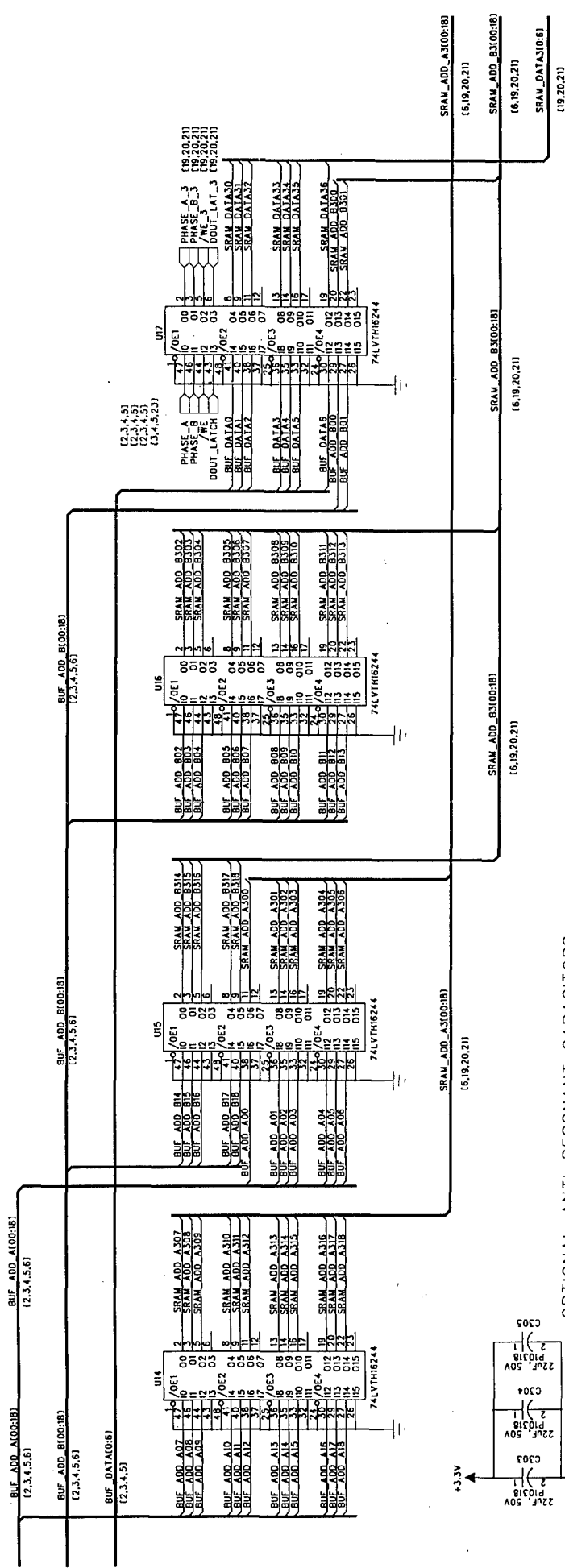

OPTIONAL ANTI-RESONANT CAPACITORS

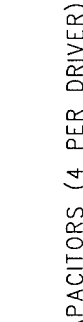

BYPASS CAPACITORS (4 PER DRIVER)

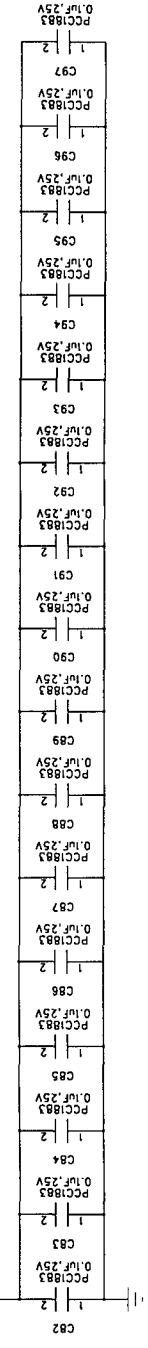

ELECTRONIC DESIGN LAB
 740-r-hhh (203)
 06601
 DESIGN BY: WF . JEP
 DRAWING# 16 6 07 31

CLIENT: DIMENSIONAL MEDIA ASSOCIATES
 PROJECT: SLM INTERFACE
 MAIN BOARD SCHEMATIC
 DATE: 4/12/00

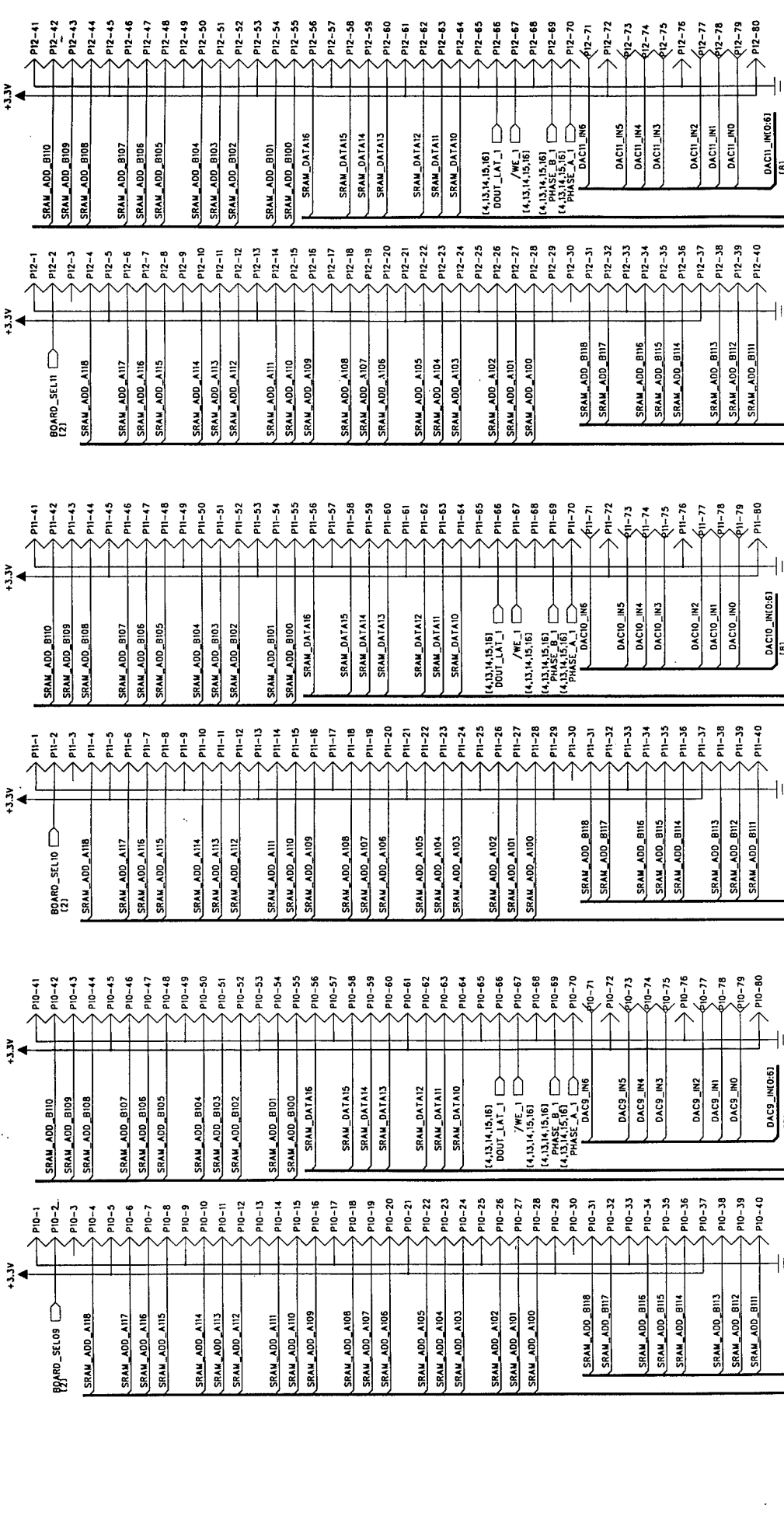

CLIENT	DIMENSIONAL MEDIA ASSOCIATES	REV
PROJECT	SILM INTERFACE	
MAIN BOARD SCHEMATIC		
DRAWING BY:	WF.	DATE
DESIGN BY:	WF.	4/12/00
JOB: 657 BOWEN, P. 14 OF 11		

ELECTRONIC DESIGN LAB
 BETHEL, CT 06801
 203.333.1203

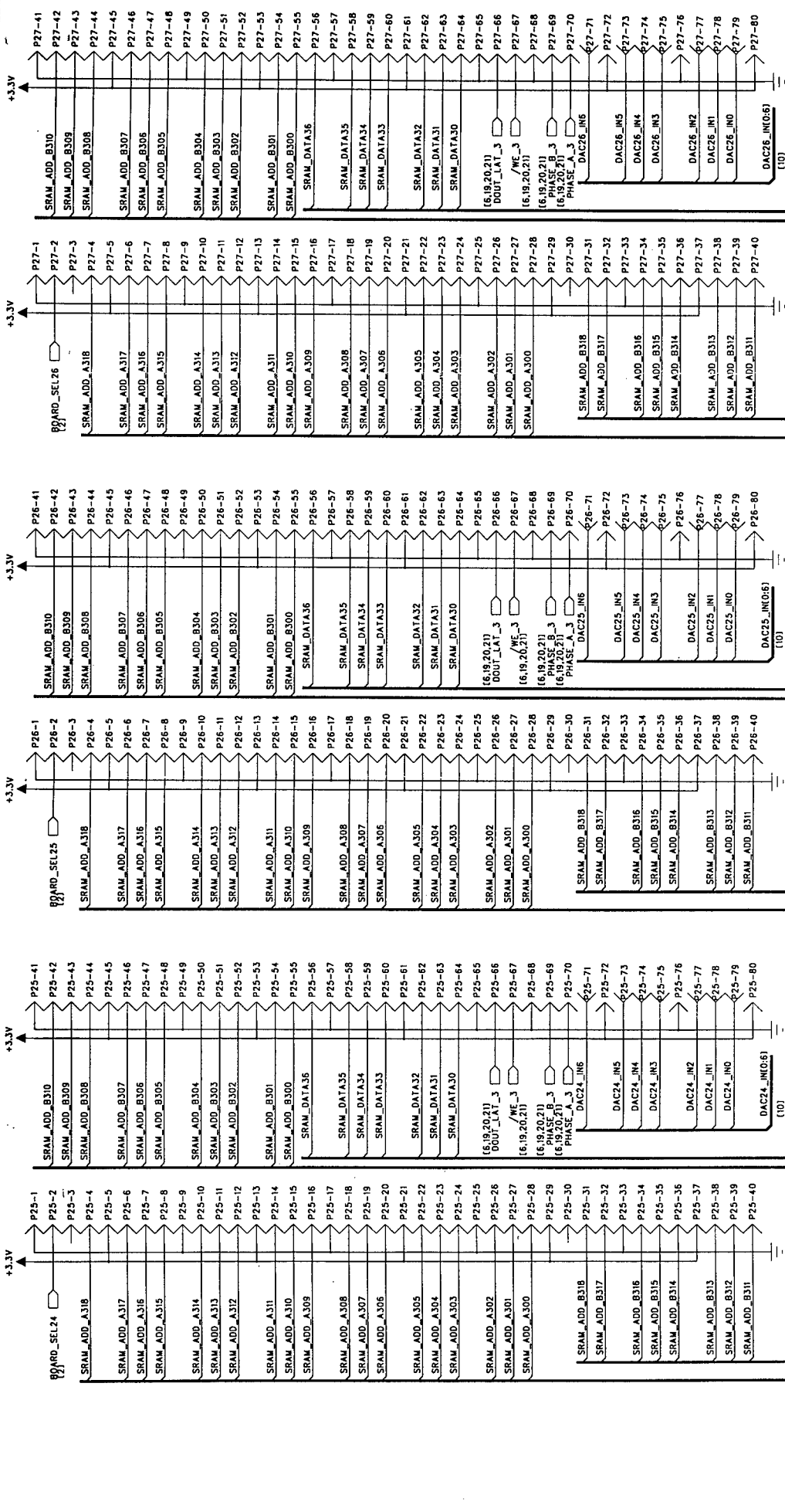

CLIENT	DIMENSIONAL MEDIA ASSOCIATES
PROJECT	SIM INTERFACE
MAIN BOARD SCHEMATIC	
DRAWING BY:	W.F.
DATE	4/19/00
DESIGN BY:	WF . JEP
INC. 007	10/10/00



ELECTRONIC DESIGN LAB
BETHEL, CT 06801
(203) ...

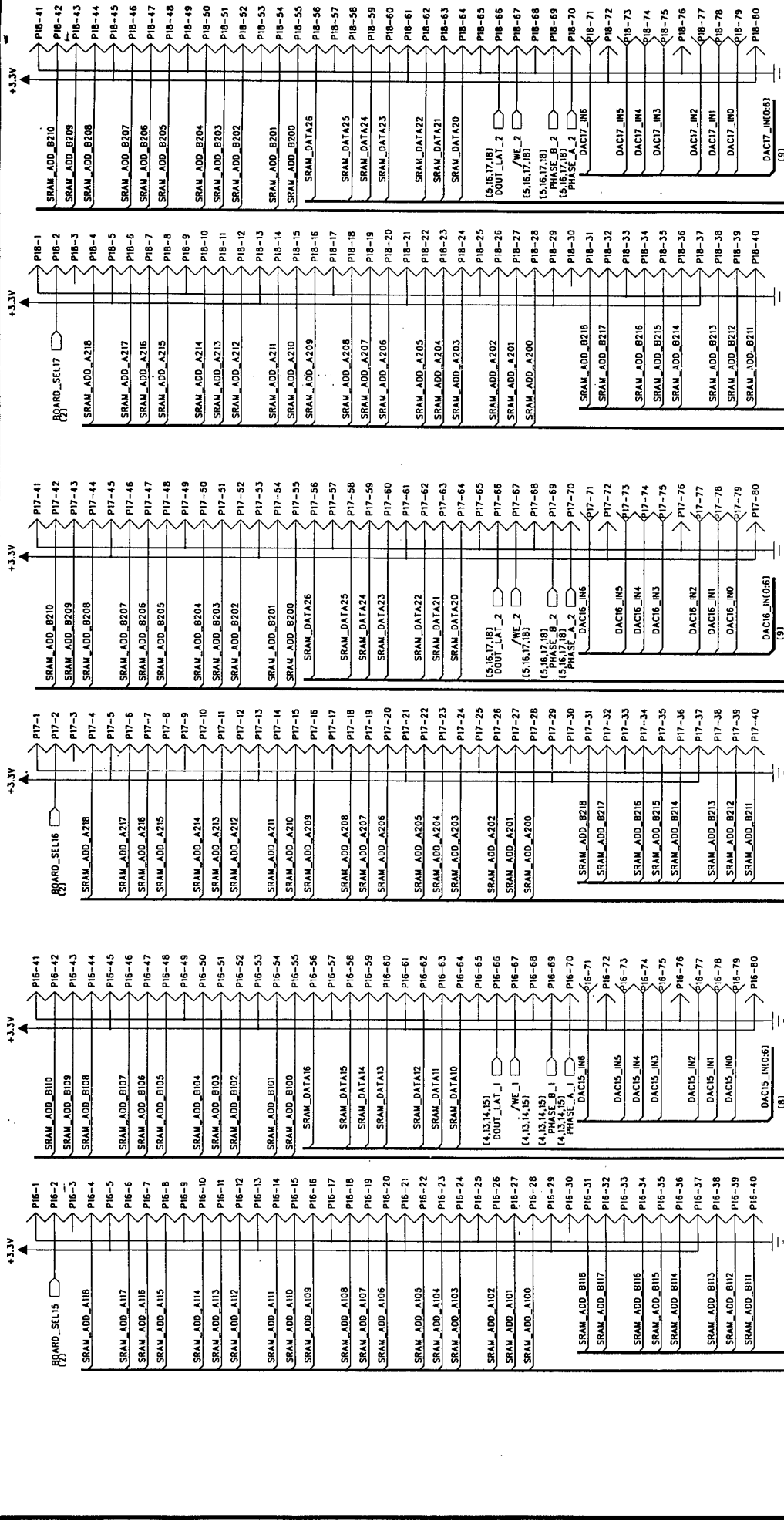

CLIENT DIMENSIONAL MEDIA ASSOCIATES		REV	DATE
PROJECT SLM INTERFACE			4/12/00
MAIN BOARD SCHEMATIC		DRAWING BY: W.F.	
DESIGN BY: W.F. JEP		06601	
DRAWING NO. 16R-667		P. 16 OF 31	

ELECTRONIC DESIGN LAB	
BETHEL, CT	
06601	
4/2000	

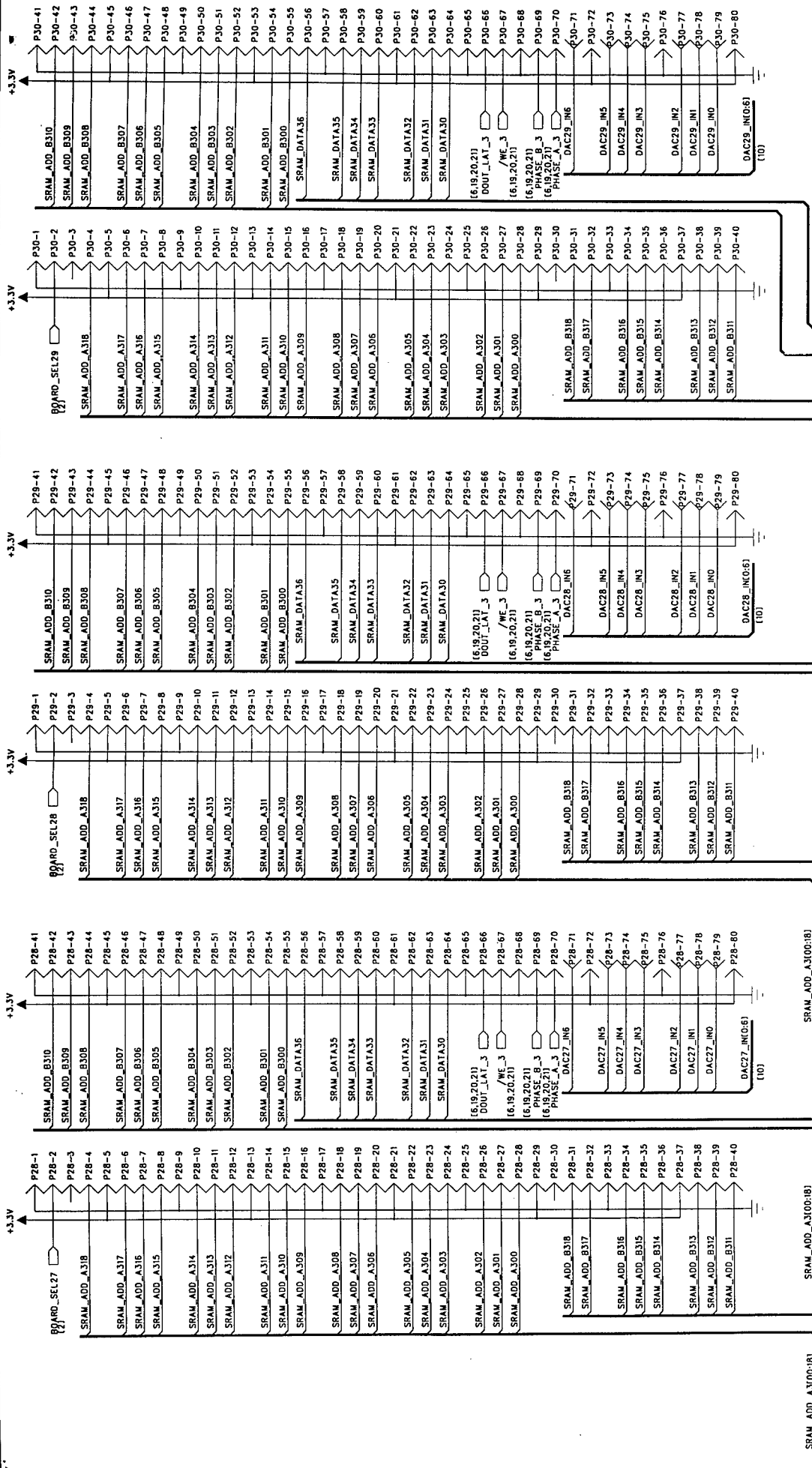

CLIENT: DIMENSIONAL MEDIA ASSOCIATES	
PROJECT: SLM INTERFACE	REV: _____
ELECTRONIC LAB DESIGN BY: W.F. DATE: 4/12/00	
DRAWING: 706-001-000	
DESIGN BY: WF . JEP	
JOB: 667 DRAWING: _____	
# 20 OF 31	

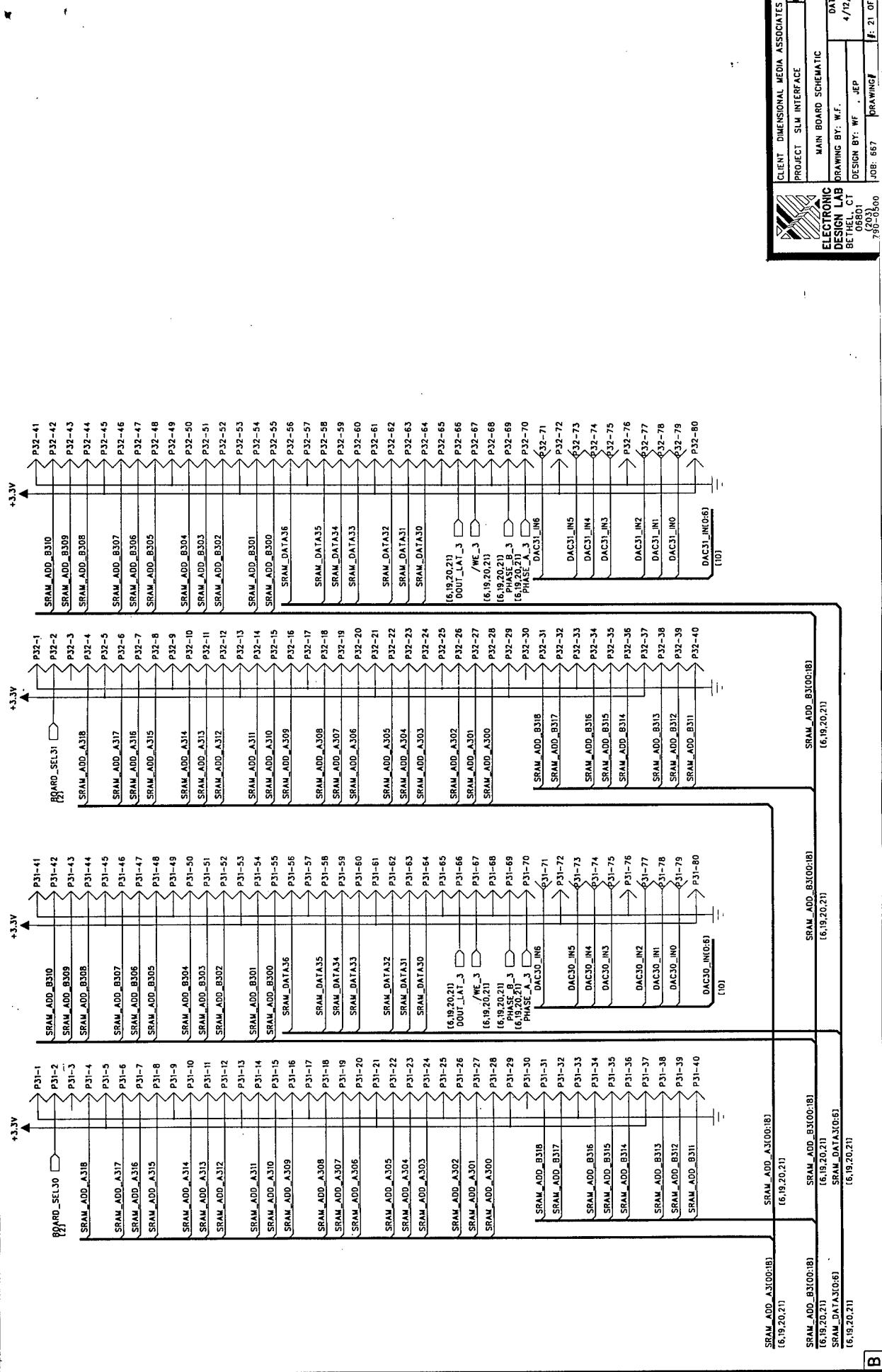

CLIENT: DIMENSIONAL MEDIA ASSOCIATES	
PROJECT: SLM INTERFACE	REV:
MAIN BOARD SCHEMATIC	
DESIGN BY: WF . JEP	DATE: 4/12/00
JOB: 667	DRAWING: F. 21 OF 31

ELECTRONIC DESIGN LAB
 BETHEL, CT 06801
 (203) 790-0500

B

FLEX 10K PROGRAM MEMORY

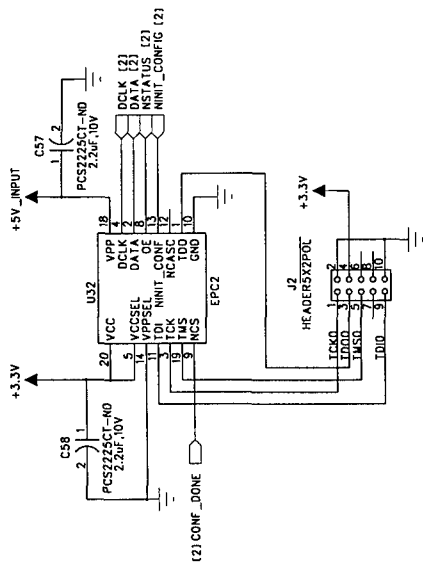

MICROCONTROLLER(MCU)

For RAMDAC programming and Power Supply Sequencing.

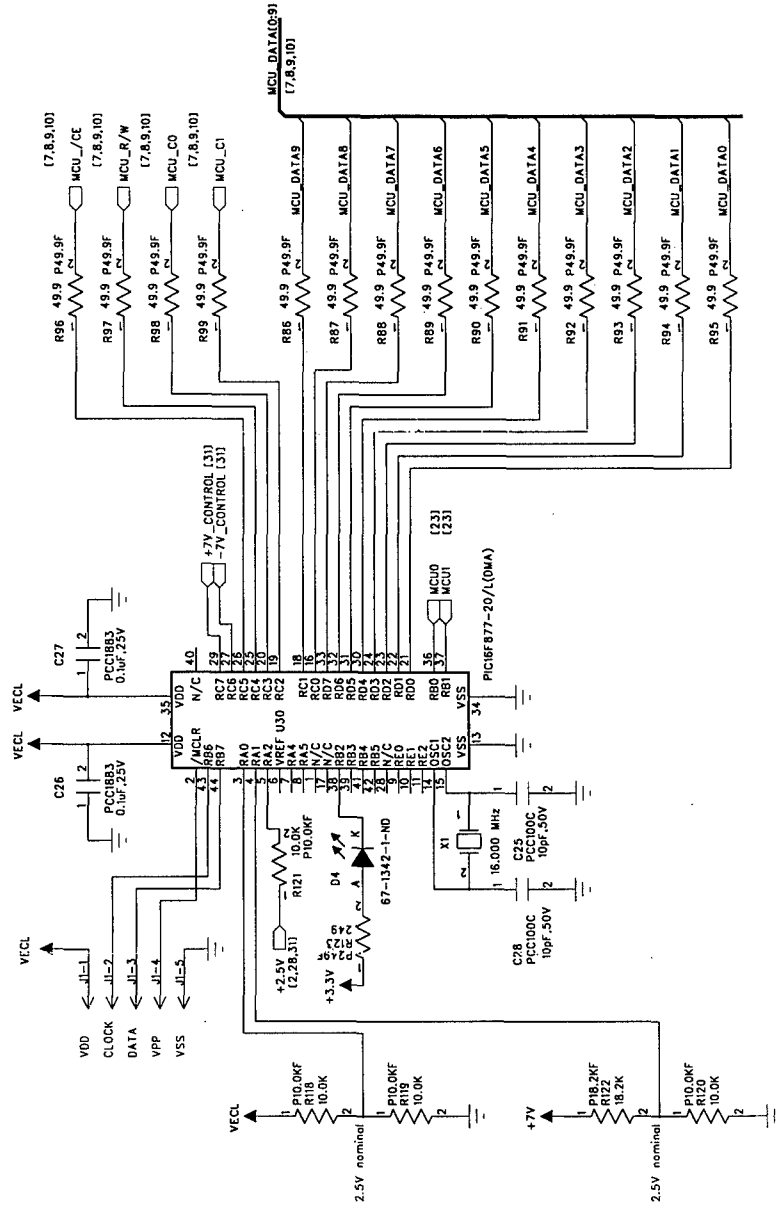

RESET SWITCH

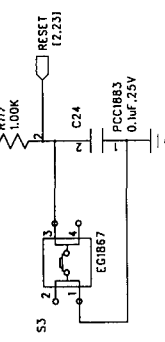

ELECTRONIC DESIGN LAB
 BEVERLY HILLS, CA 91601
 (310) 277-0000
 FAX: (310) 277-0000

CLIENT: DIMENSIONAL MEDIA ASSOCIATES
 PROJECT: SLM INTERFACE
 MAIN BOARD SCHEMATIC
 DRAWING BY: WF
 DATE: 4/12/00
 DESIGN BY: WF . JEP
 JOB: 667 DRAWING: 790-0500

SLM OUTPUT LOGIC

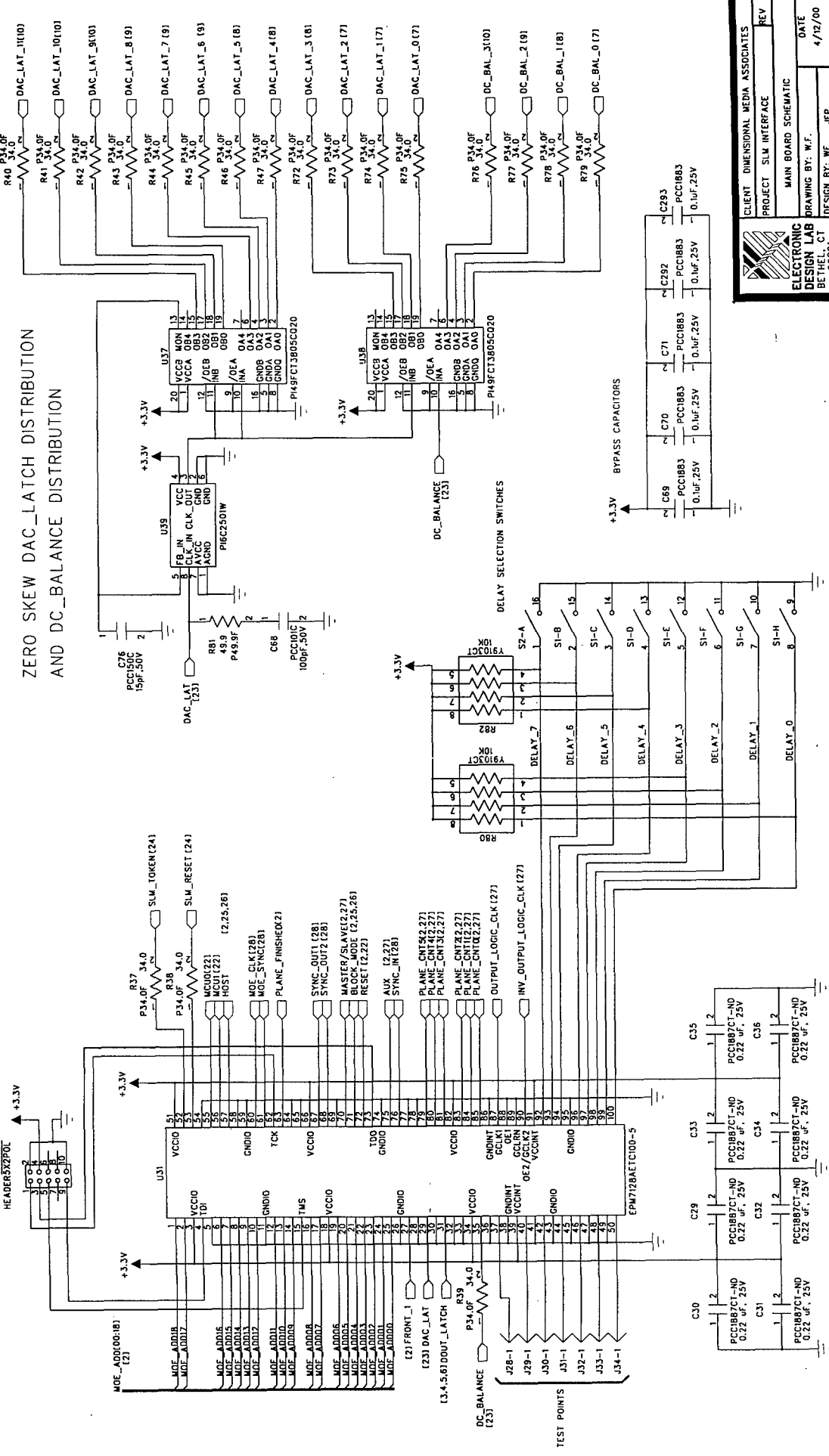

ZERO SKEW DAC_LATCH DISTRIBUTION AND DC_BALANCE DISTRIBUTION

CLIENT: DIMENSIONAL MEDIA ASSOCIATES
 PROJECT: SLM INTERFACE
 MAIN BOARD SCHEMATIC
 DRAWING BY: W.F.
 DATE: 4/12/00
 DESIGN BY: W.F.
 JOB: 667
 DRAWING#: 75025500
 # 23 OF 31

OUTPUT CONNECTOR, TRANSLATOR AND TERMINATIONS

SLM TTL TO PECL TRANSLATOR

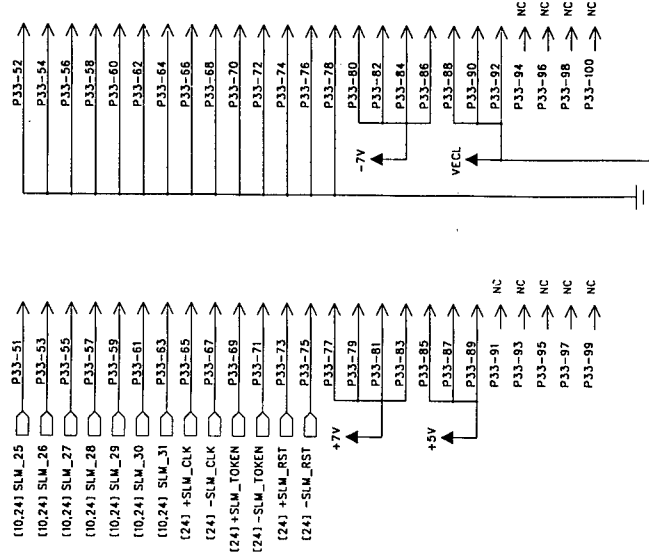
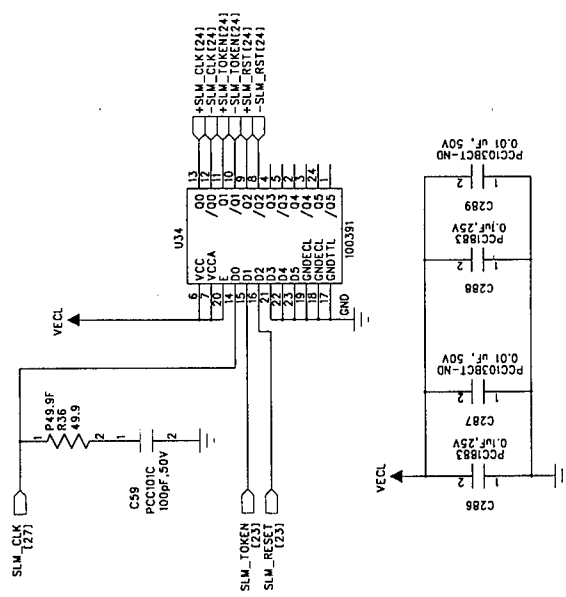

DATA SIGNAL SOURCE END TERMINATION RESISTORS

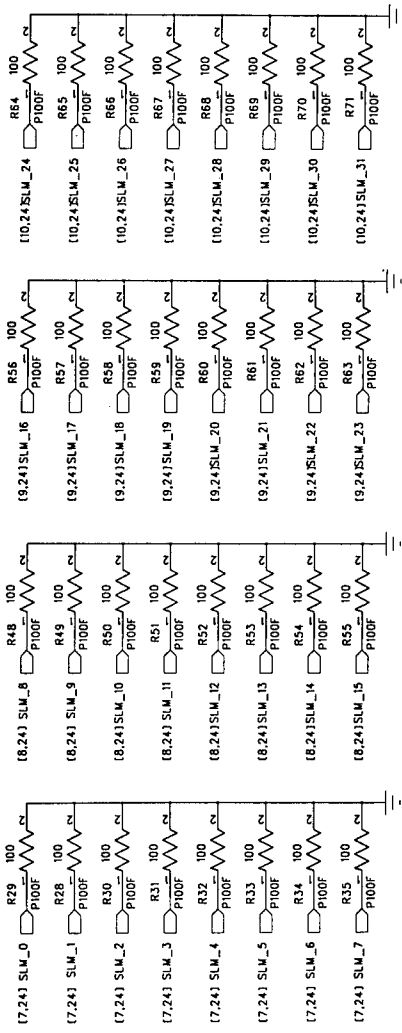

ELECTRONIC DESIGN LAB
 BETHEL, CT 06801
 (203) 261-8800

CLIENT: DIMENSIONAL MEDIA ASSOCIATES
 PROJECT: SLM INTERFACE
 DRAWING BY: W.F.
 DESIGN BY: WF .JEP
 DATE: 4/19/00

INPUT CONNECTOR AND TERMINATIONS

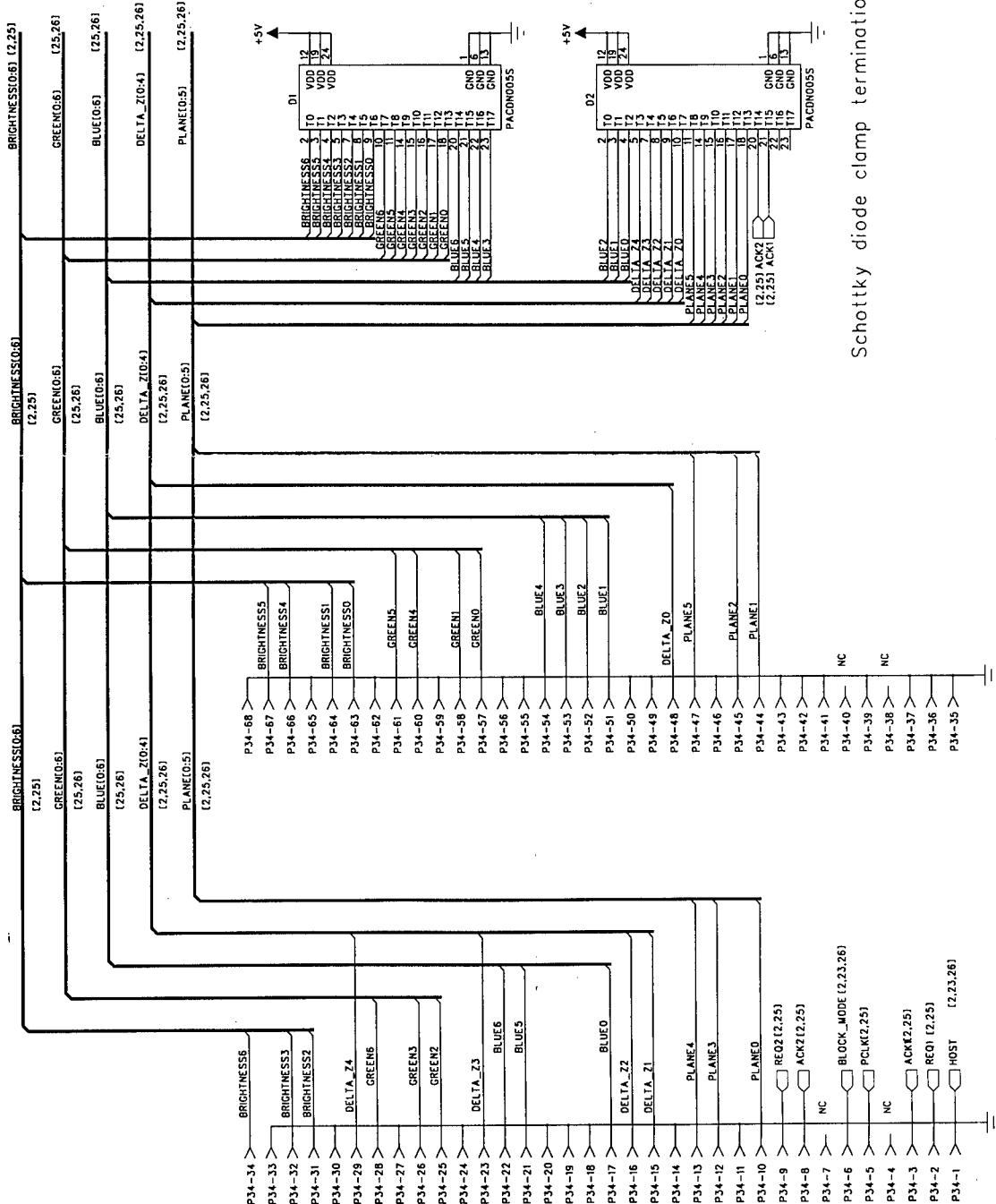

PULL UP RESISTORS

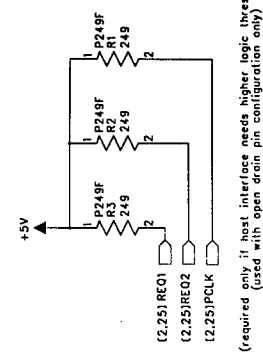

Schottky diode clamp terminations

	CLIENT	DIMENSIONAL MEDIA ASSOCIATES
	PROJECT	SLM INTERFACE
MAIN BOARD SCHEMATIC		REV
DRAWING BY: W.F.		DATE
DESIGN BY: WF . JEP		4/12/00
JOB: 657		DRAWING#
75623300		# 25 OF 31

DATE: 04.10.00 1:14:40 23.11.00 0000

OUTPUTS TO SLAVE CARDS

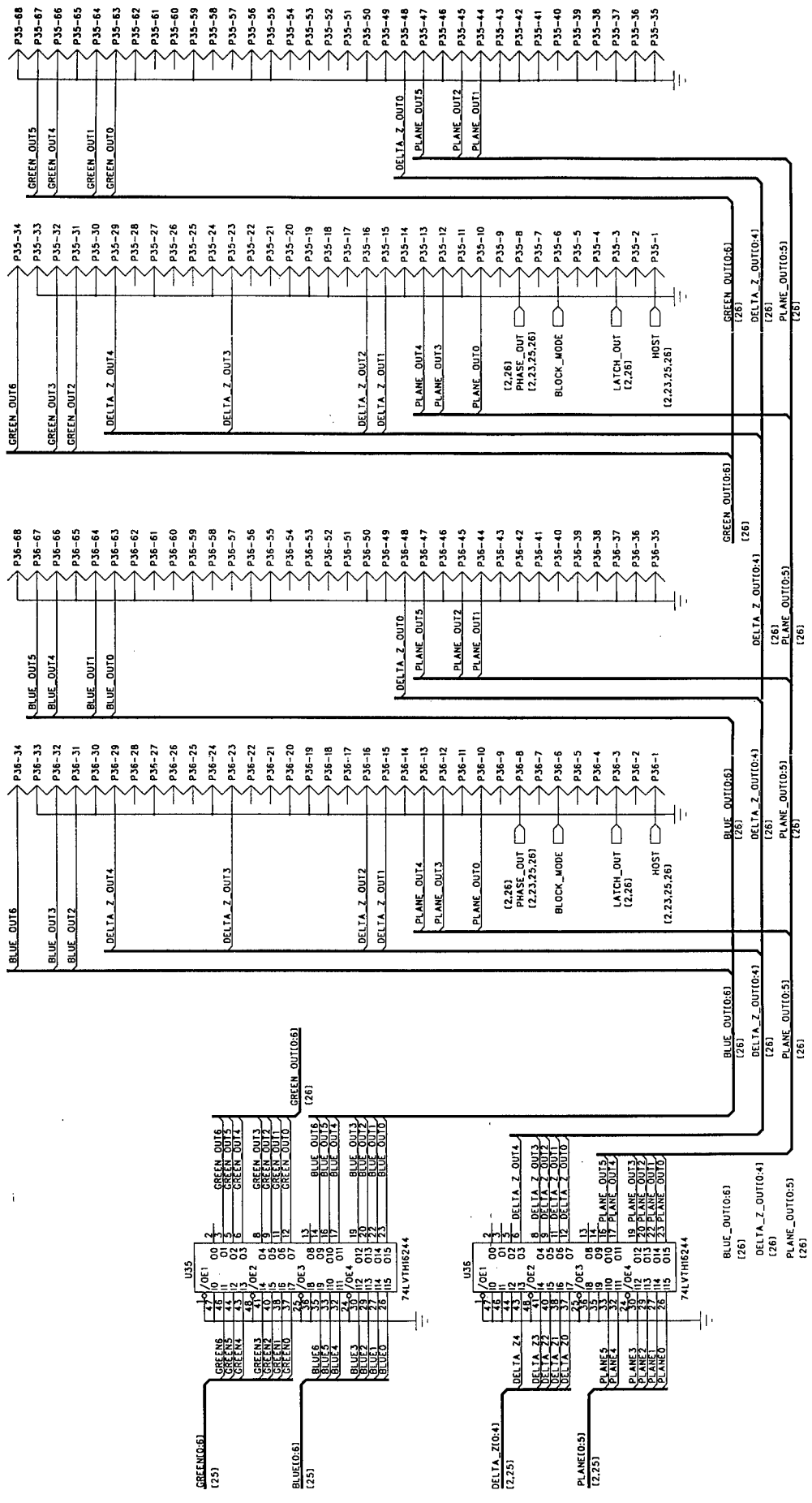

CLIENT DIMENSIONAL MEDIA ASSOCIATES

PROJECT SLM INTERFACE

DATE 4/12/00

DESIGN BY: WF . JEP

JOB: 667 DRAWING: 390-0500

741VTH6244

741VTH6244

ELECTRONIC DESIGN LAB

BETHEL CT 06801

741VTH6244

741VTH6244

MAIN BOARD SCHEMATIC

DATE 4/12/00

DESIGN BY: WF . JEP

JOB: 667 DRAWING: 390-0500

CLIENT DIMENSIONAL MEDIA ASSOCIATES

PROJECT SLM INTERFACE

DATE 4/12/00

DESIGN BY: WF . JEP

JOB: 667 DRAWING: 390-0500

ELECTRONIC DESIGN LAB

BETHEL CT 06801

741VTH6244

741VTH6244

MAIN BOARD SCHEMATIC

DATE 4/12/00

DESIGN BY: WF . JEP

JOB: 667 DRAWING: 390-0500

CLIENT DIMENSIONAL MEDIA ASSOCIATES

PROJECT SLM INTERFACE

DATE 4/12/00

DESIGN BY: WF . JEP

JOB: 667 DRAWING: 390-0500

ELECTRONIC DESIGN LAB

BETHEL CT 06801

741VTH6244

741VTH6244

MAIN BOARD SCHEMATIC

DATE 4/12/00

DESIGN BY: WF . JEP

JOB: 667 DRAWING: 390-0500

SLM CLOCK SOURCE AND DISTRIBUTION

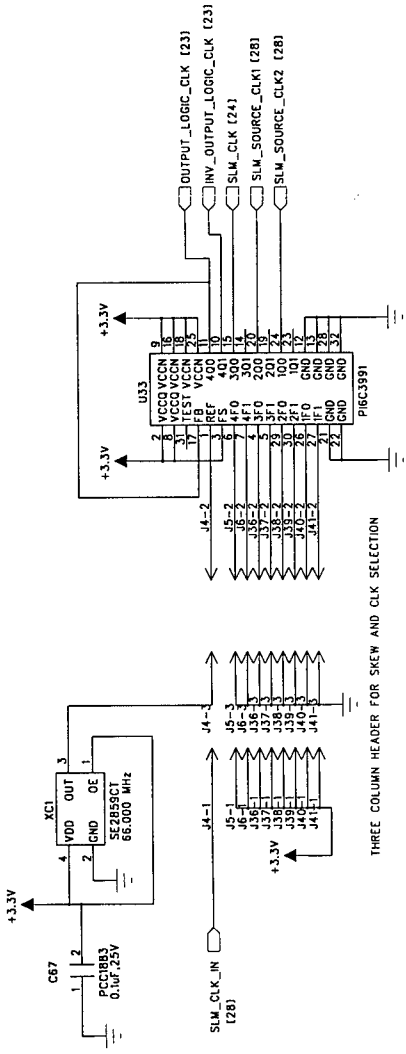

FRONT END CLOCK SOURCE AND DISTRIBUTION

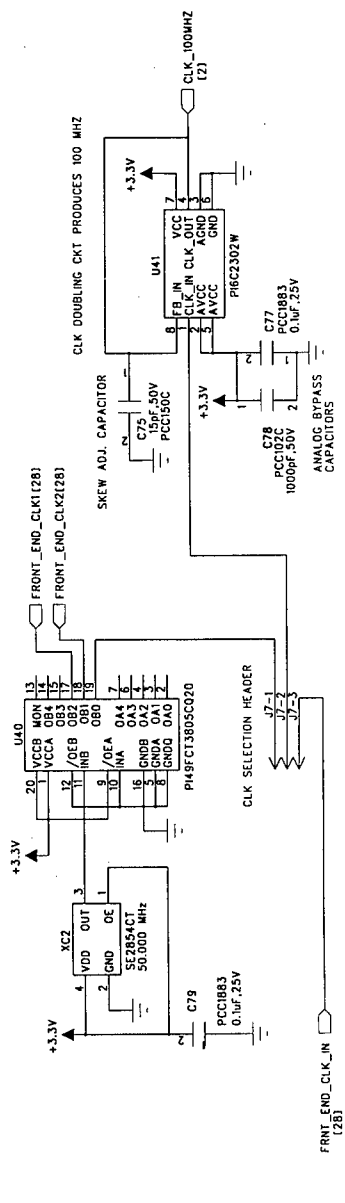

U33 BYPASS CAPACITORS

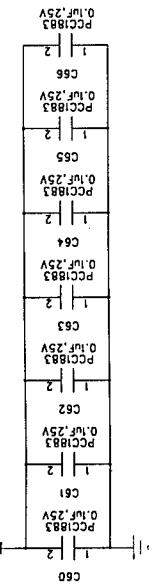

U40, U41 BYPASS CAPACITORS

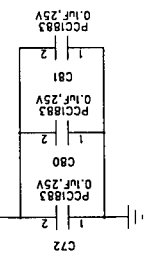

PLANE COUNT, MASTER/SLAVE AND AUX SELECTION SWITCHES

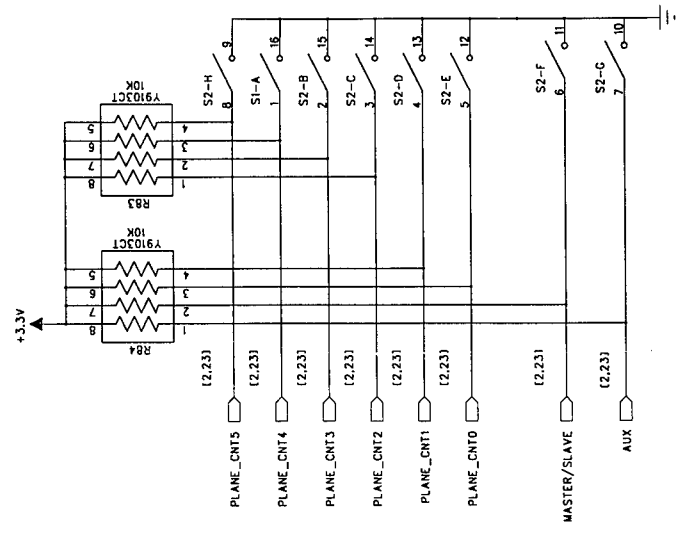

ELECTRONIC DESIGN LAB
 BE THEL, CT
 06801
 (203)
 790-0500

CLIENT: DIMENSIONAL MEDIA ASSOCIATES
 PROJECT: SLM INTERFACE
 MAIN BOARD SCHEMATIC
 DRAWING BY: W.F.
 DESIGN BY: W.F. JEP
 JOB: 667 DRAWING: 1

DATE: 4/12/00
 P: 27 OF 31

BNC CONNECTORS WITH TERMINATIONS

OUTPUTS

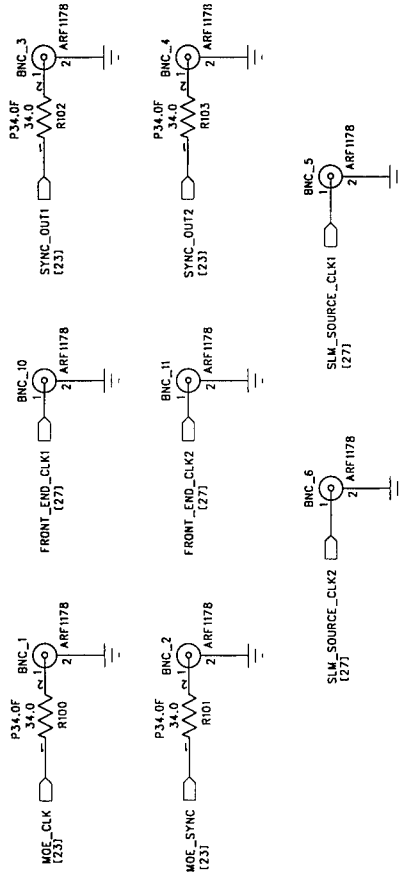

INPUTS

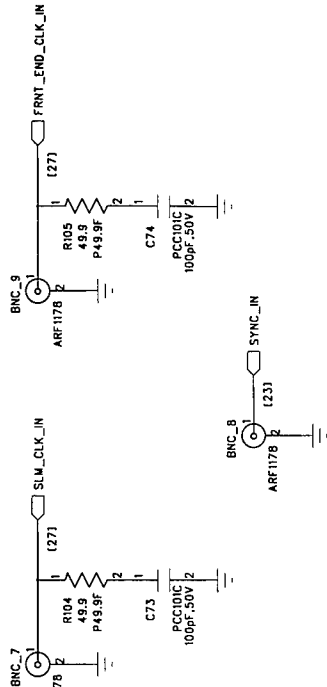

+3.3V POWER CONNECTORS AND FILTER CAPACITORS

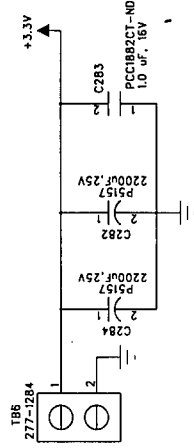
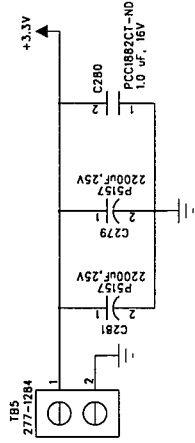
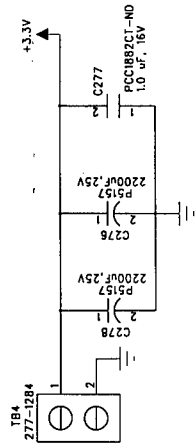

POWER INDICATORS

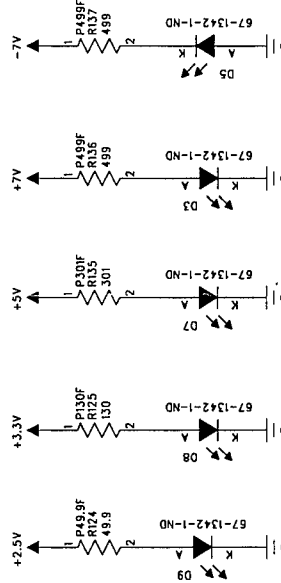

CLIENT: DIMENSIONAL MEDIA ASSOCIATES
 PROJECT: SLM INTERFACE
 MAIN BOARD SCHEMATIC
 DATE: 4/12/00
 DRAWING BY: W.F.
 DESIGN BY: W.F.
 JOB: 667
 DRAWING#: 790-05000
 [F: 28 OF 31]

SAMZ-SCN-62-77 - 111 JUL 20 13:47:14 2000

RAMDAC VAA BYPASS CAPACITORS

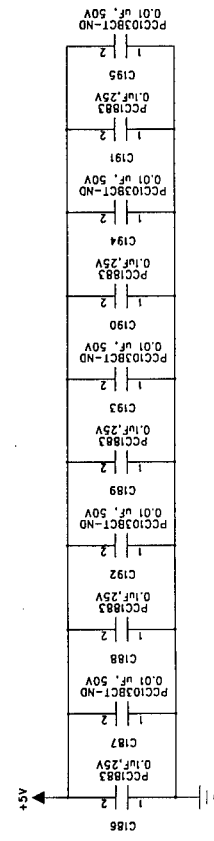
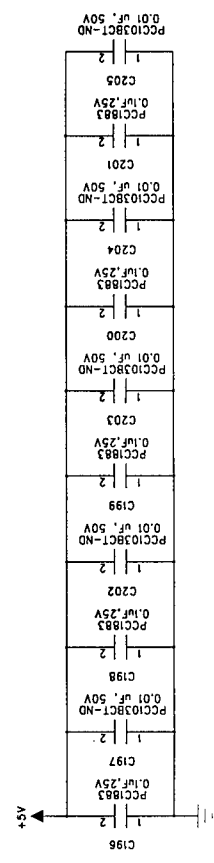
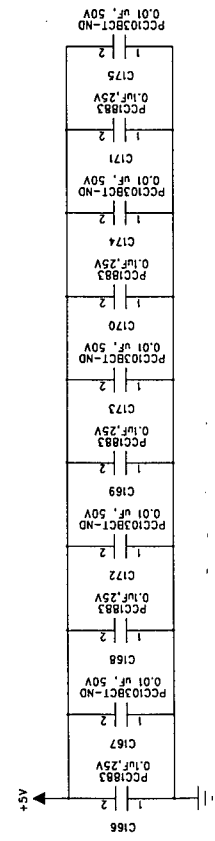
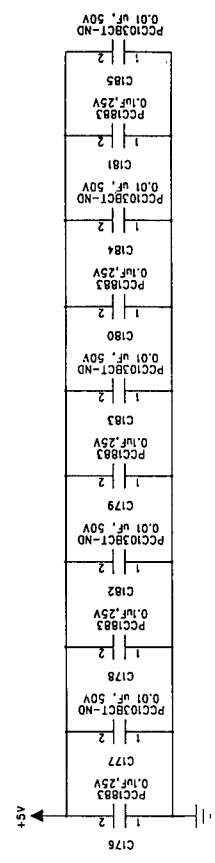
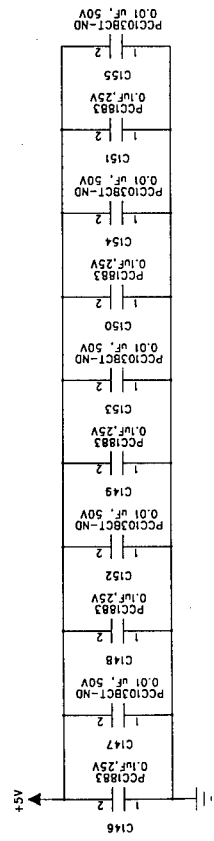
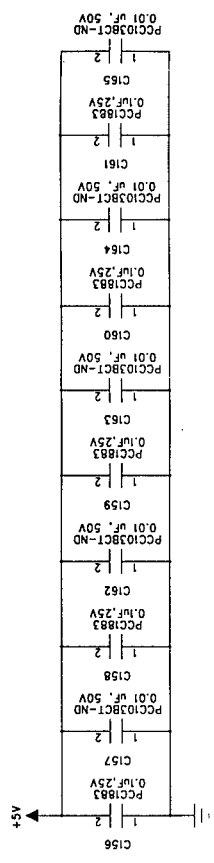

CLIENT: DIMENSIONAL MEDIA ASSOCIATES
 PROJECT: SLM INTERFACE
 MAIN BOARD SCHEMATIC
 DRAWING BY: W.F.
 DATE: 4/12/00
 DESIGN BY: W.F.
 JOB: 667
 DRAWING: 796-0500
 (203)

RAMDAC VAA BYPASS CAPACITORS

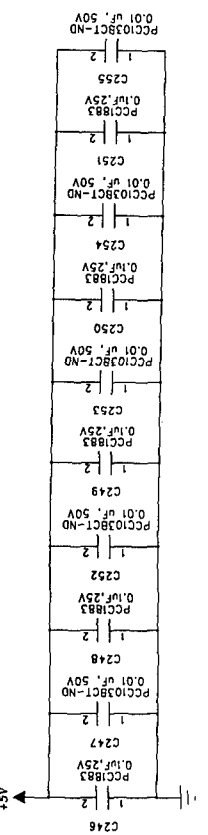
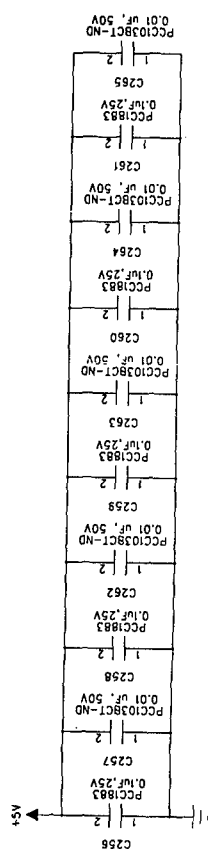
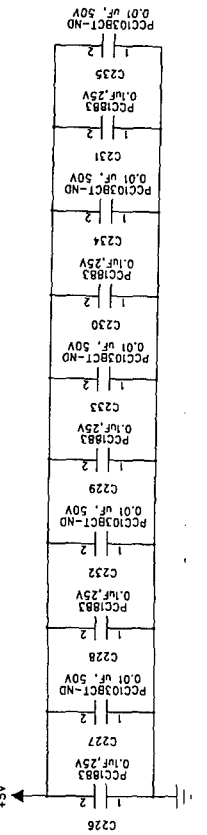
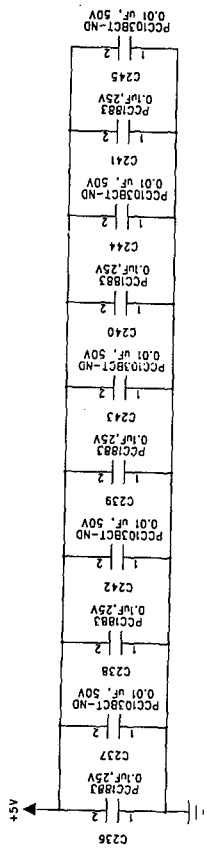
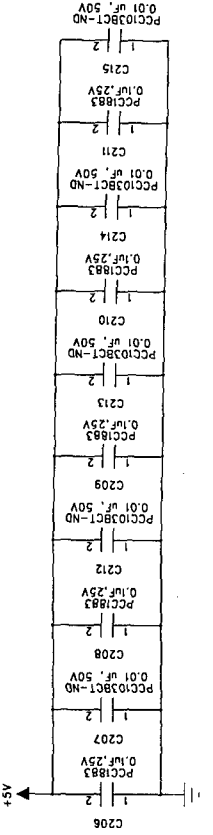
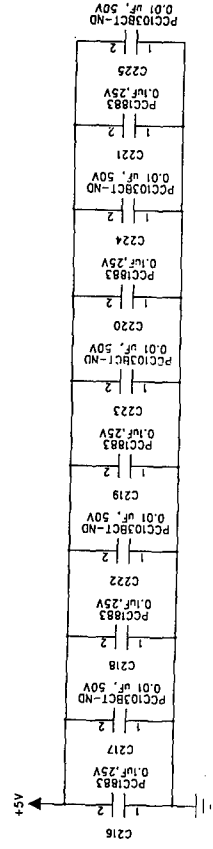

CLIENT: DIMENSIONAL MEDIA ASSOCIATES
 PROJECT: SLIM INTERFACE
 MAIN BOARD SCHEMATIC
 DRAWING BY: W.F.
 DATE: 4/12/00
 DESIGN BY: W.F. JEP
 08801
 ELECTRONIC DESIGN LAB
 BETHEL, CT

+5V ANALOG SUPPLY VOLTAGE FILTER

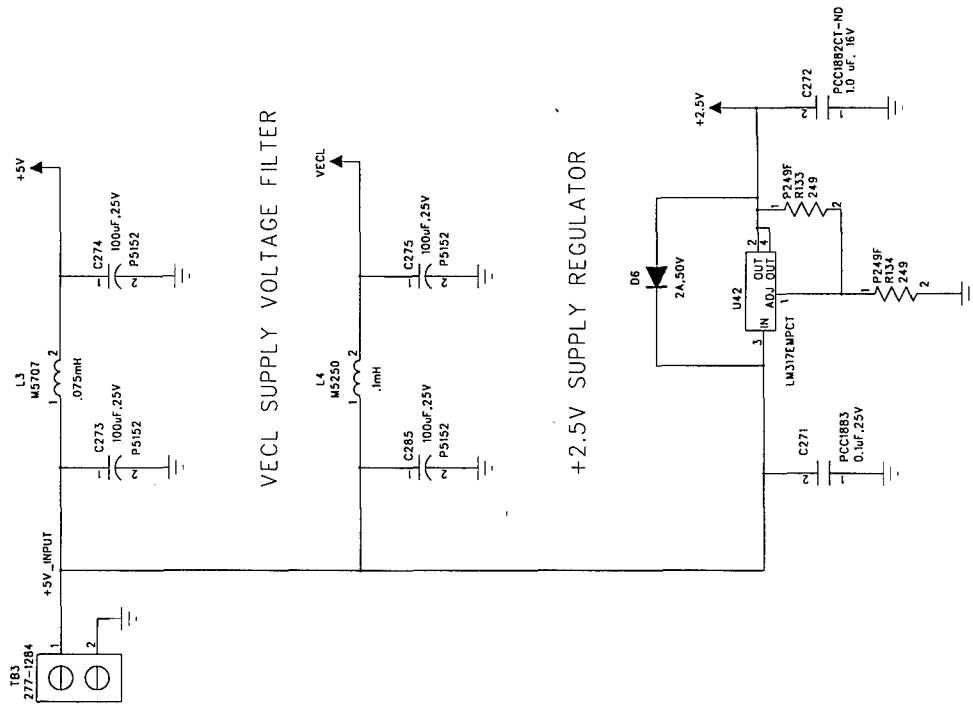

VECL SUPPLY VOLTAGE FILTER

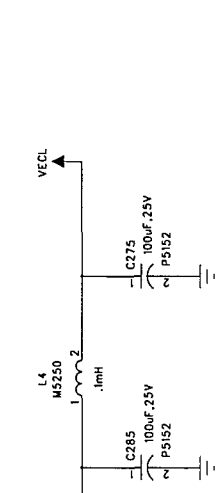

+2.5V SUPPLY REGULATOR

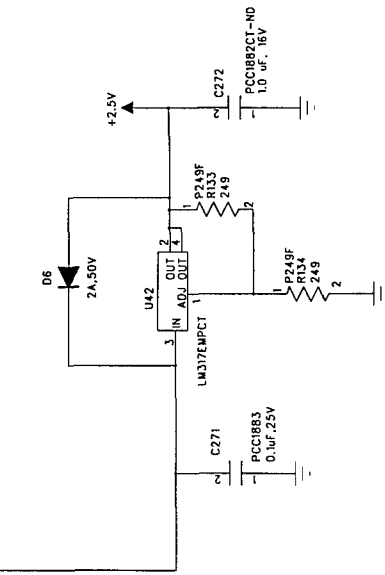

ANALOG SUPPLY VOLTAGE FILTERS AND SWITCHES

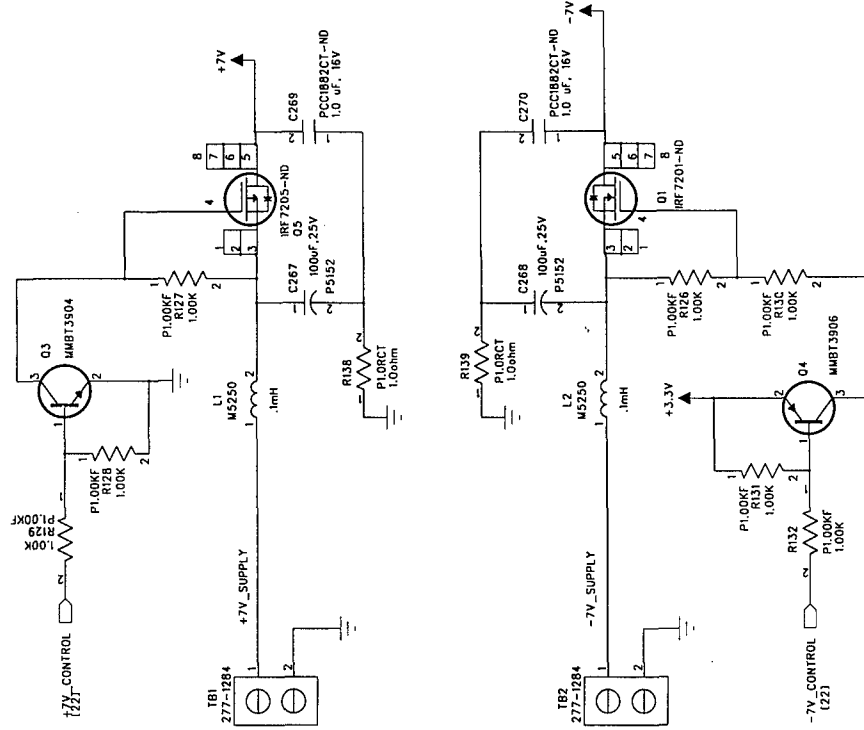

CLIENT: DIMENSIONAL MEDIA ASSOCIATES	
PROJECT: SLM INTERFACE	REV:
ELECTRONIC DESIGN LAB	
DRAWING BY: W.F.	
DATE: 4/12/00	
DESIGN BY: W.F.	
JOB: 667 DRAWING: 31	

BYPASS CAPACITORS

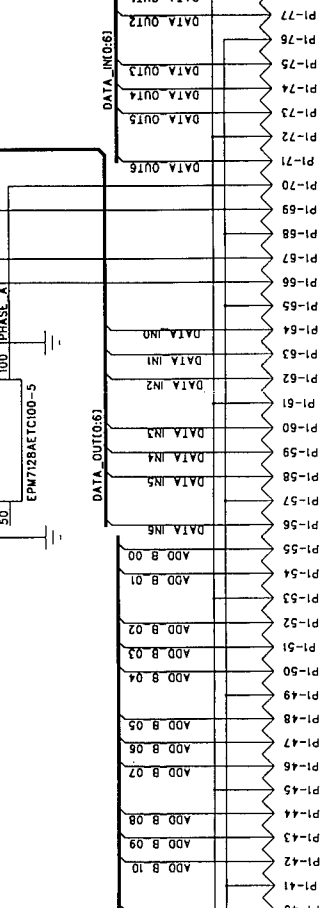
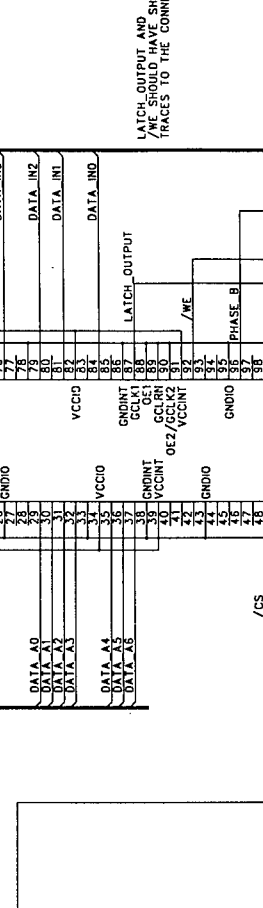
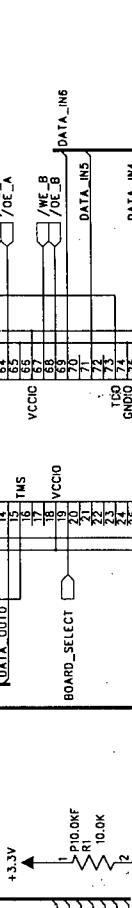
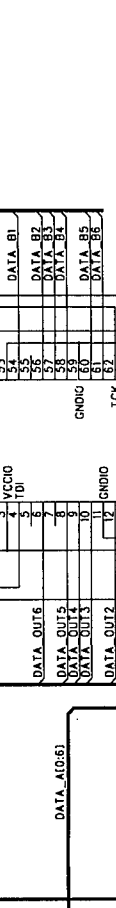
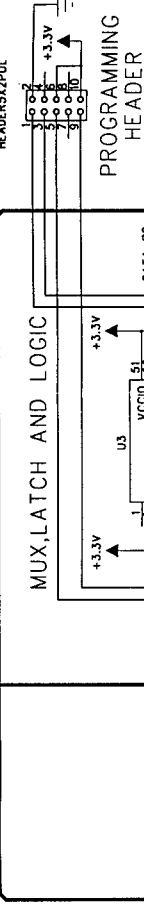

80 PIN EDGE CONNECTOR

CLIENT: Dimensional Media Associates
 PROJECT: SLM Interface
 Memory board
 DRAWING BY: W.F.
 DESIGN BY: W.F.
 DATE: 3/23/00
 ELECTRONIC DESIGN LAB
 BETHESDA, CT 06801
 (203) 780-0500
 DRAWING# F: 1 OF 1

F. Vacuum chamber mechanical drawings

The following pages contain the mechanical drawings of the vacuum chamber designed to be used for filling the large MOE liquid crystal shutter cells.

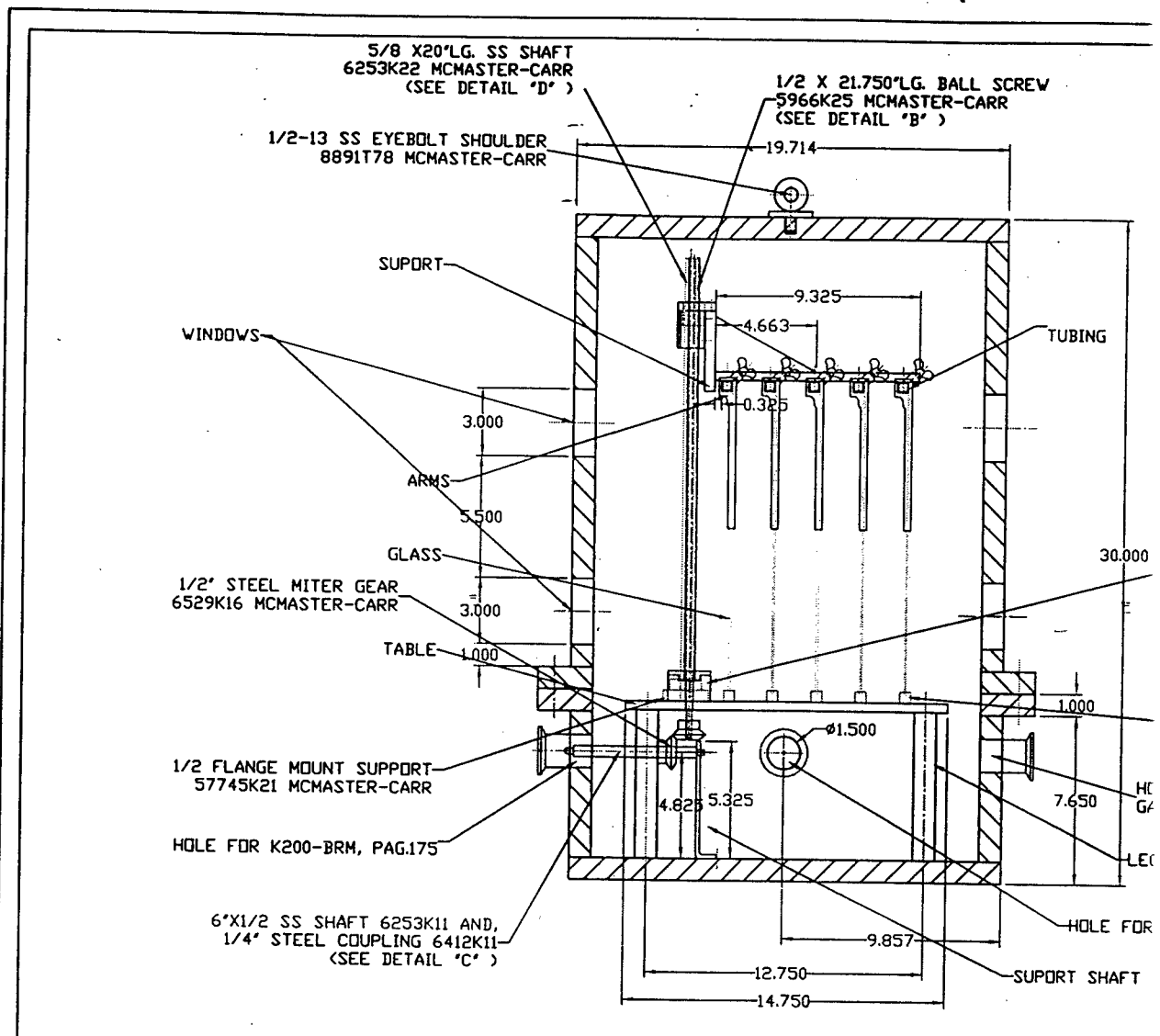

SECTION A-A

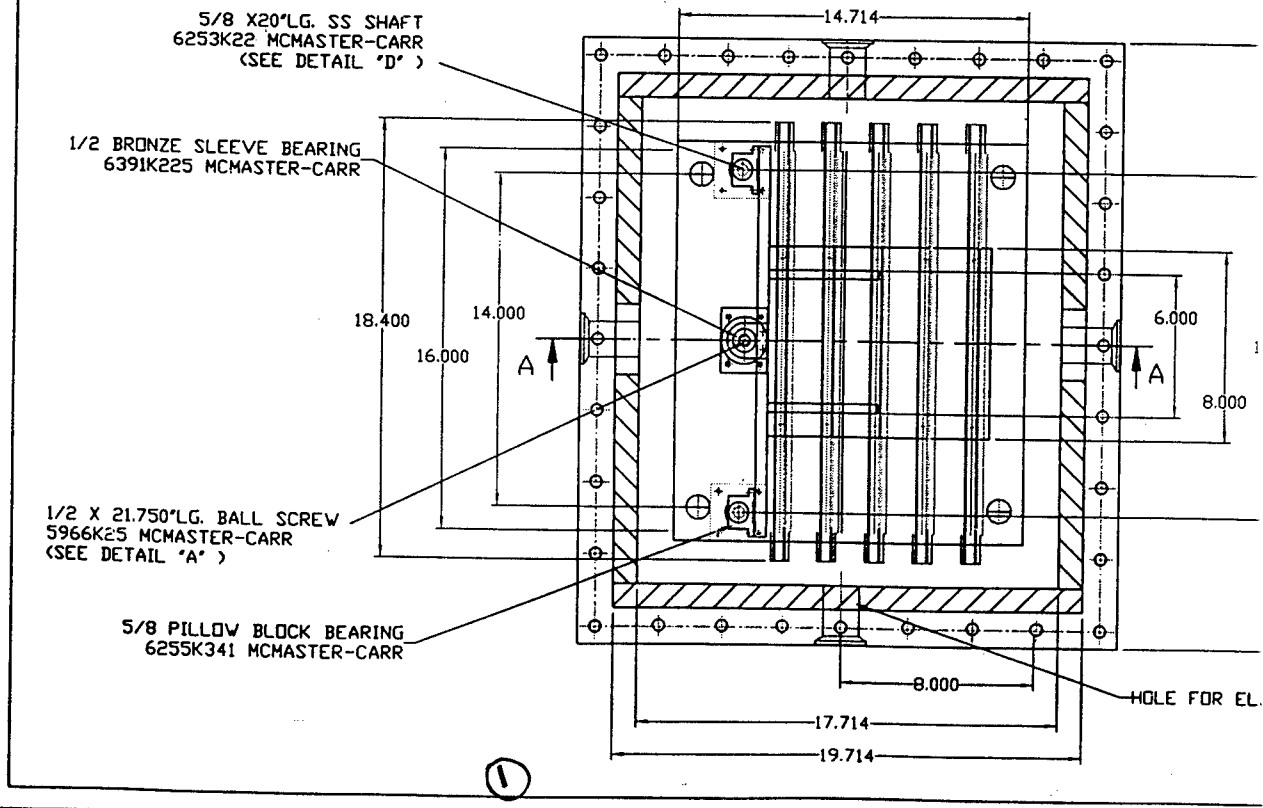

5/8 X 20" LG. SS SHAFT
253K22 MCMaster-CARR
(SEE DETAIL 'D')

1/2 X 21.750" LG. BALL SCREW
5966K25 MCMaster-CARR
(SEE DETAIL 'B')

1/4 X 20 ON 5/8 DEEP
BOTH ENDS

S EYEBOLT SHOULDER
1T78 MCMaster-CARR

SUPPORT

ARMS

GLASS

GEAR CARR

TABLE

SUPPORT ER-CARR

PAG.175

T 6253K11 AND,
UPLING 6412K11
(SEE DETAIL 'C')

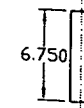
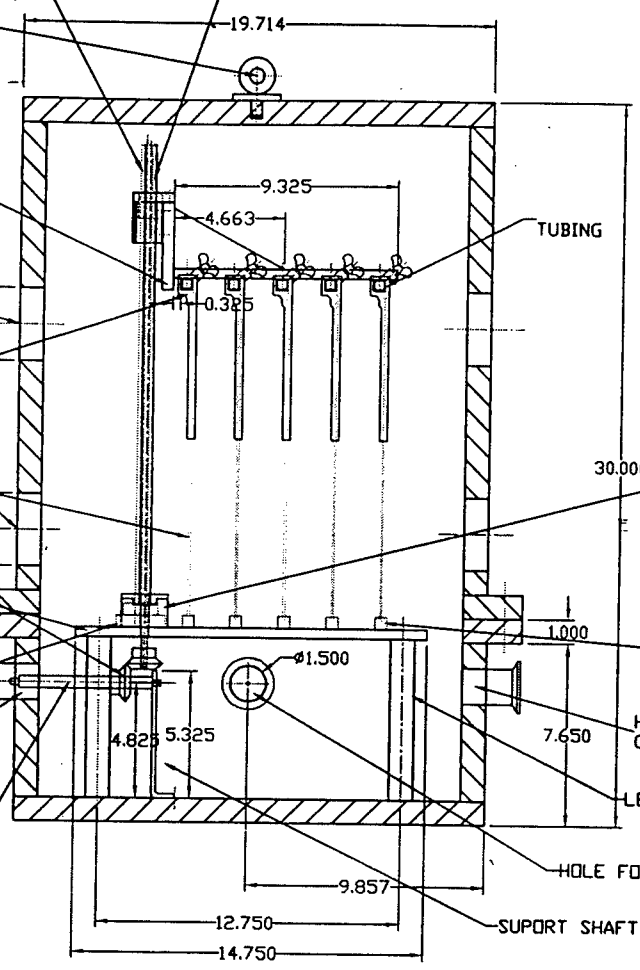

LEG 4 PCS./ASSY.

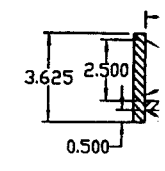

SECT

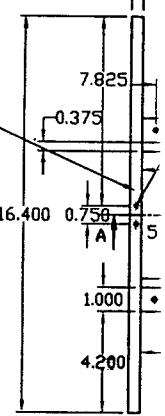

1 pc./assy.

1/2 END MOUNTING BLOCK
60755K12 MCMaster-CARR
1/2 FLANGE BALL NUT 5966K45

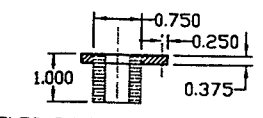

2 HOLES 3/16
R0.750

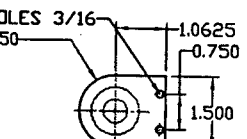

SCALE 2:1
SUPPORT BUSHING
1 PC./ASSY.

BAR

HOLE FOR INSTRUM.
GAGE PRESURE

LEGS

HOLE FOR VACUUM PUMP

SUPPORT SHAFT

SECTION A-A

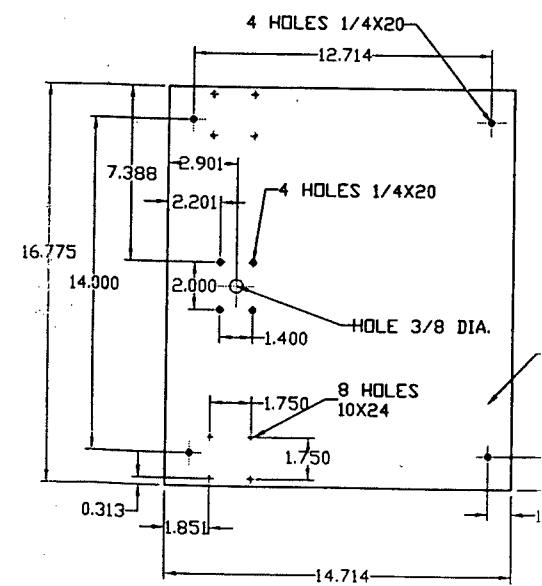
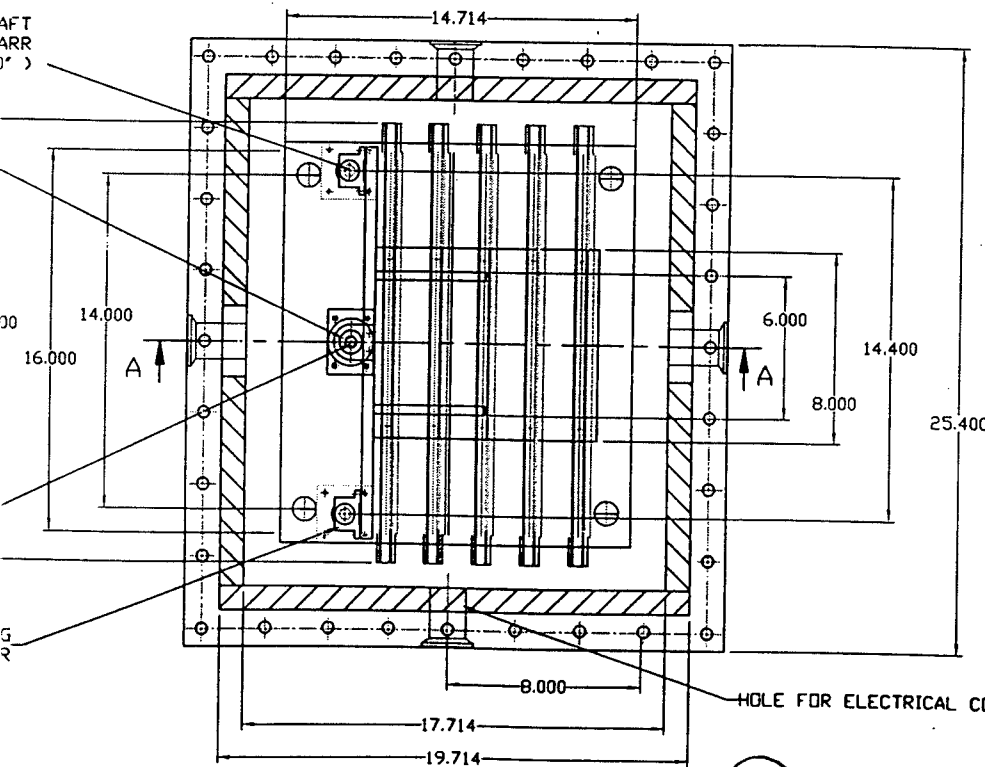
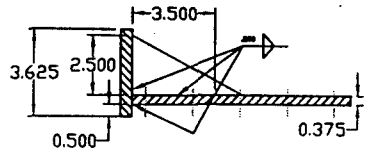

TABLE 1" THK.
1 PC./ASSY.

2

Rev	By	Date	Ap'd	Description
A	CP	24 JUL 98		INITIAL REL
<p>All information on this drawing is proprietary and must not be copied or disclosed without from Dimensional Media Associates, Inc. This is returned to Dimensional Media Associates, Inc. upon request.</p>				

.000



SECTION A-A

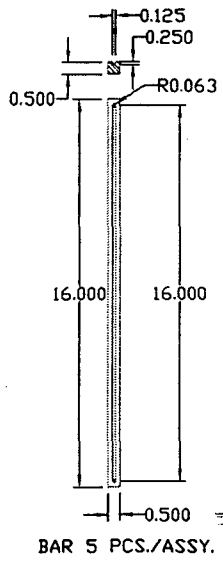
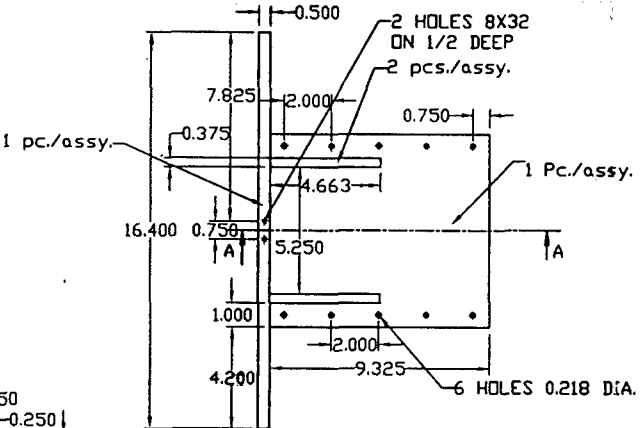

BAR 5 PCS./ASSY.

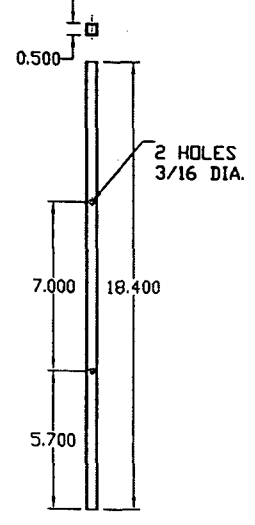

TUBING 5 PCS./ASSY.

.K45

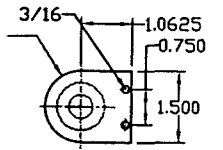
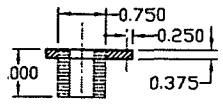

SCALE 2:1
SUPPORT BUSHING
1 PC./ASSY.

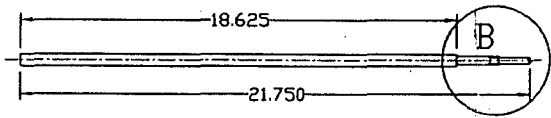

5/8X21.750 BALL SCREW
1PC./ASSY.

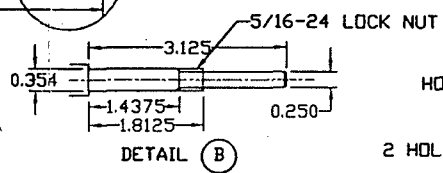

DETAIL B

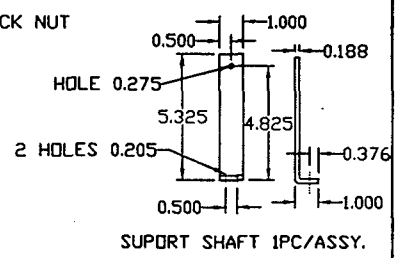

SUPPORT SHAFT 1PC./ASSY.

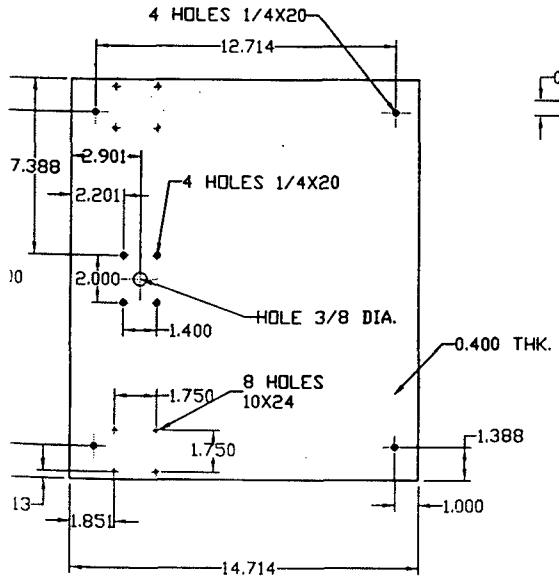
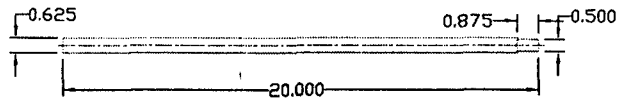
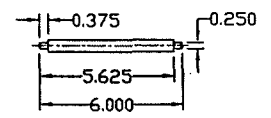

TABLE 1' THK.
1PC./ASSY.



SS GUIDE SHAFT
2PCS./ASSY.
DETAIL 'D'



DETAIL 'C' SS SHAFT
1PC./ASSY.

				Customer	Job Number	 DIMENSIONAL MEDIA ASSOCIATES, INC. New York, New York				
				Det#	Qty					Material
						MATL1 ALUMINUM		Break sharp edges		
						MATL2		Drawn CP 24JUL98 Check CP 24JUL98 App'd JB 24JUL98		
						MATL3		Scale Drawing Number Rev		
A	CP	24JUL98	INITIAL RELEASE					1:1	100100-01	A
Rev	By	Date	Ap'd	Description						
All information on this drawing is proprietary and confidential and must not be copied or disclosed without written authorization from Dimensional Media Associates, Inc. This document must be returned to Dimensional Media Associates, Inc. immediately upon request.										
Tolerances Unless Otherwise Noted: Whole Nos. and Fractions: ±1/32 Angles ±30° .XXX Decimals ±.010 .XX Decimals ±.020										

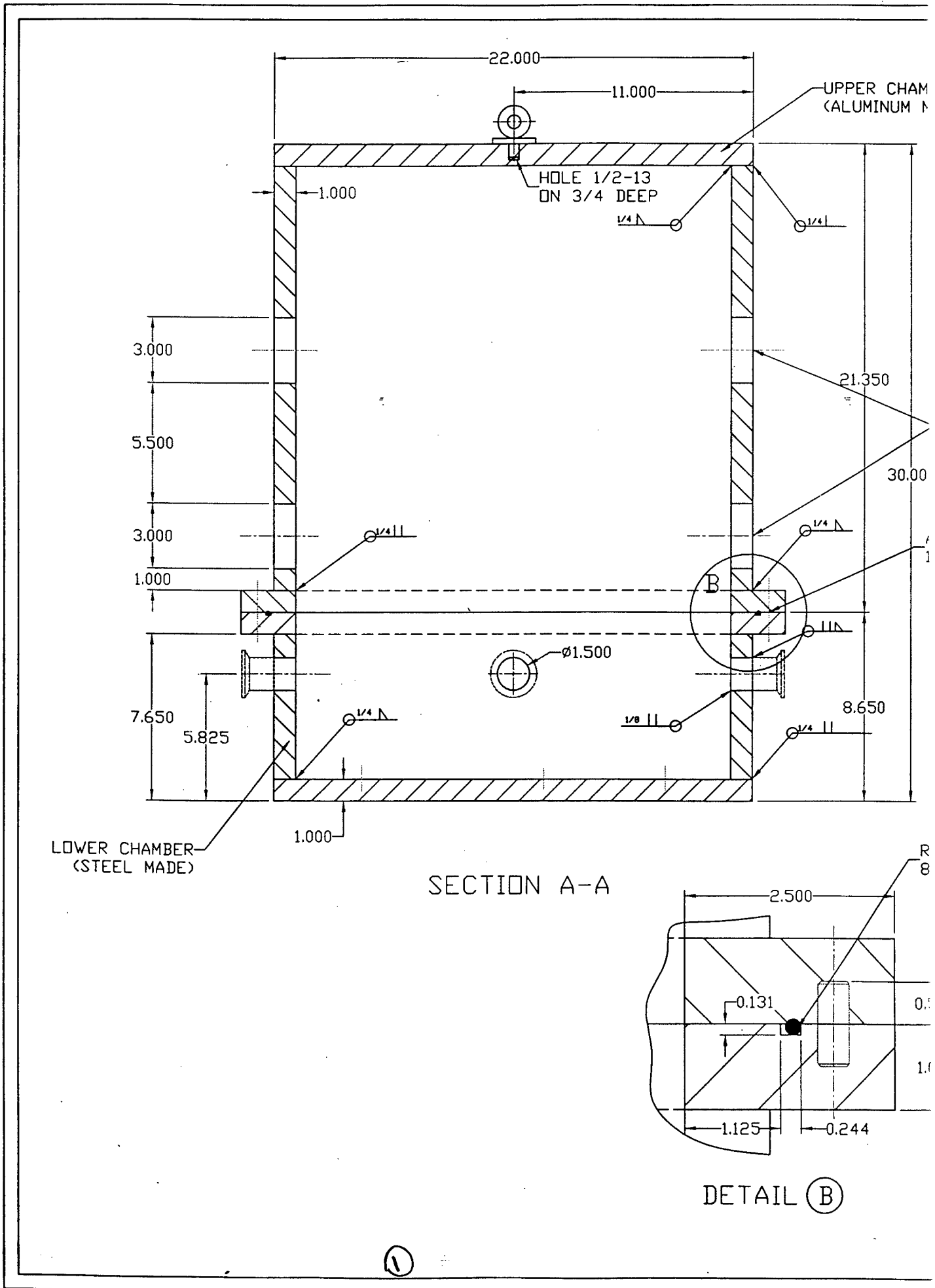

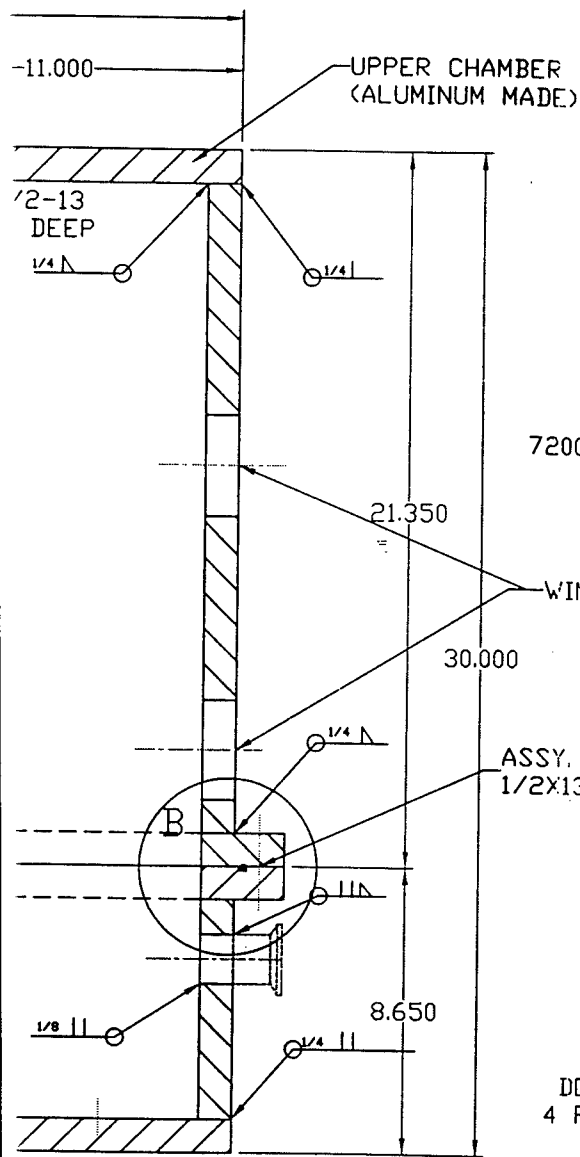

HALF NIPPLE NW40
720003 MDE 4PCS./ASSY.

DOWEL PINS 3/8 X 1" LONG
4 PCS./ASSY. 98381A624
MCMaster-CARR

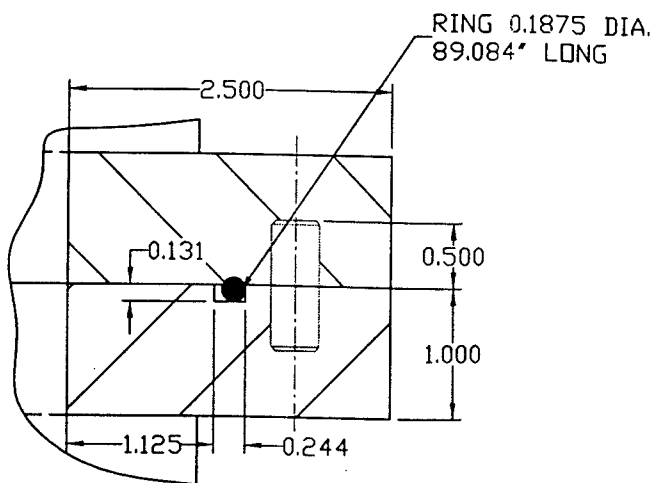

DETAIL B

2

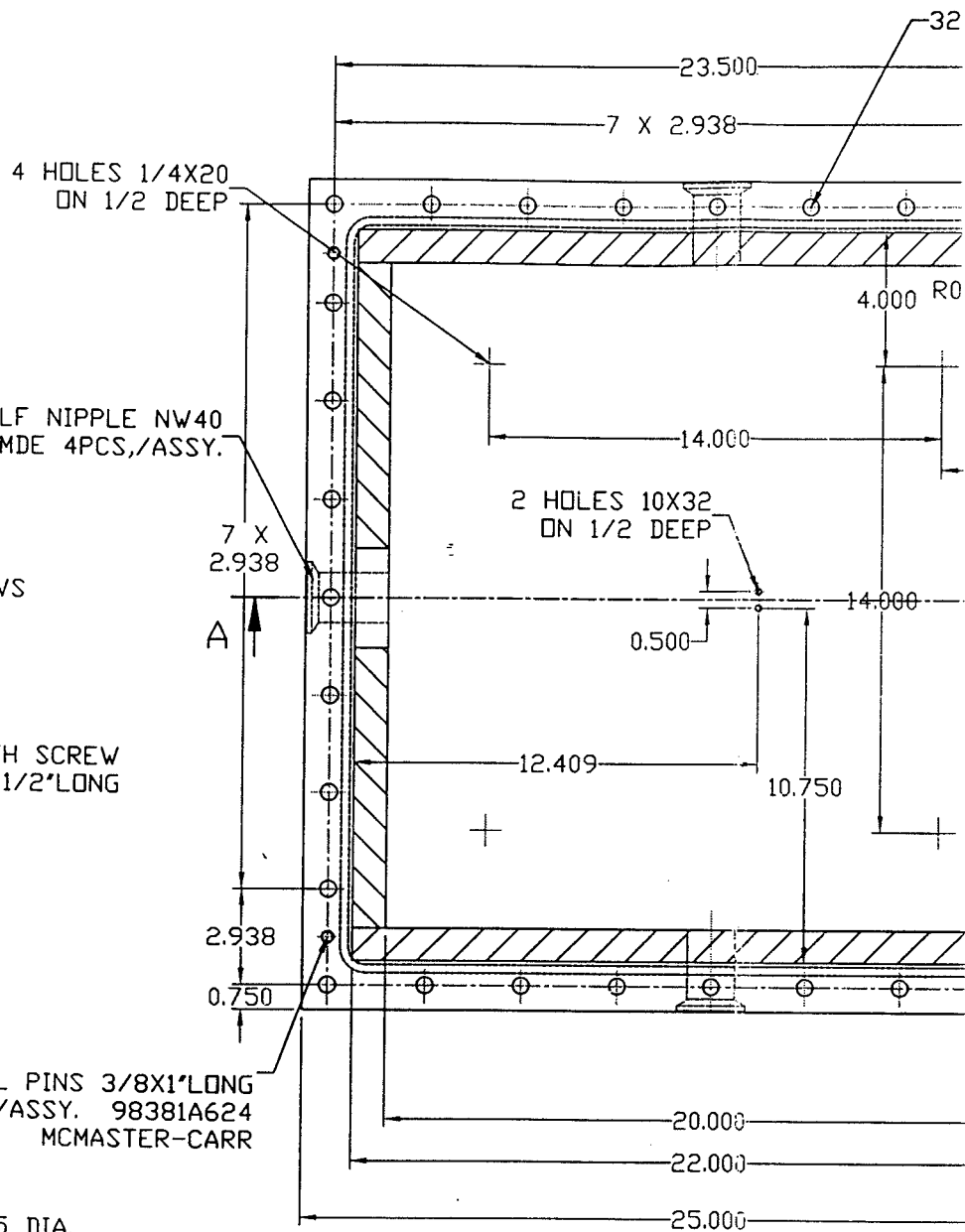

Customer				Job Number	
Det#	Qty	Material			
		MATL1			
		MATL2			
		MATL3			
A	CP	4AUG98	INITIAL RELEASE		
Rev	By	Date	Ap'd	Description	
All information on this drawing is proprietary and confidential and must not be copied or disclosed without written authorization from Dimensional Media Associates, Inc. This document must be returned to Dimensional Media Associates, Inc. immediately upon request.					
Intolerance Unless Otherwise Noted: Whole Nos. and Fractions: ±1/32 Angles ±30' .XXX Decimals ±.010 .XX Decimals ±.020					

100100-01 A

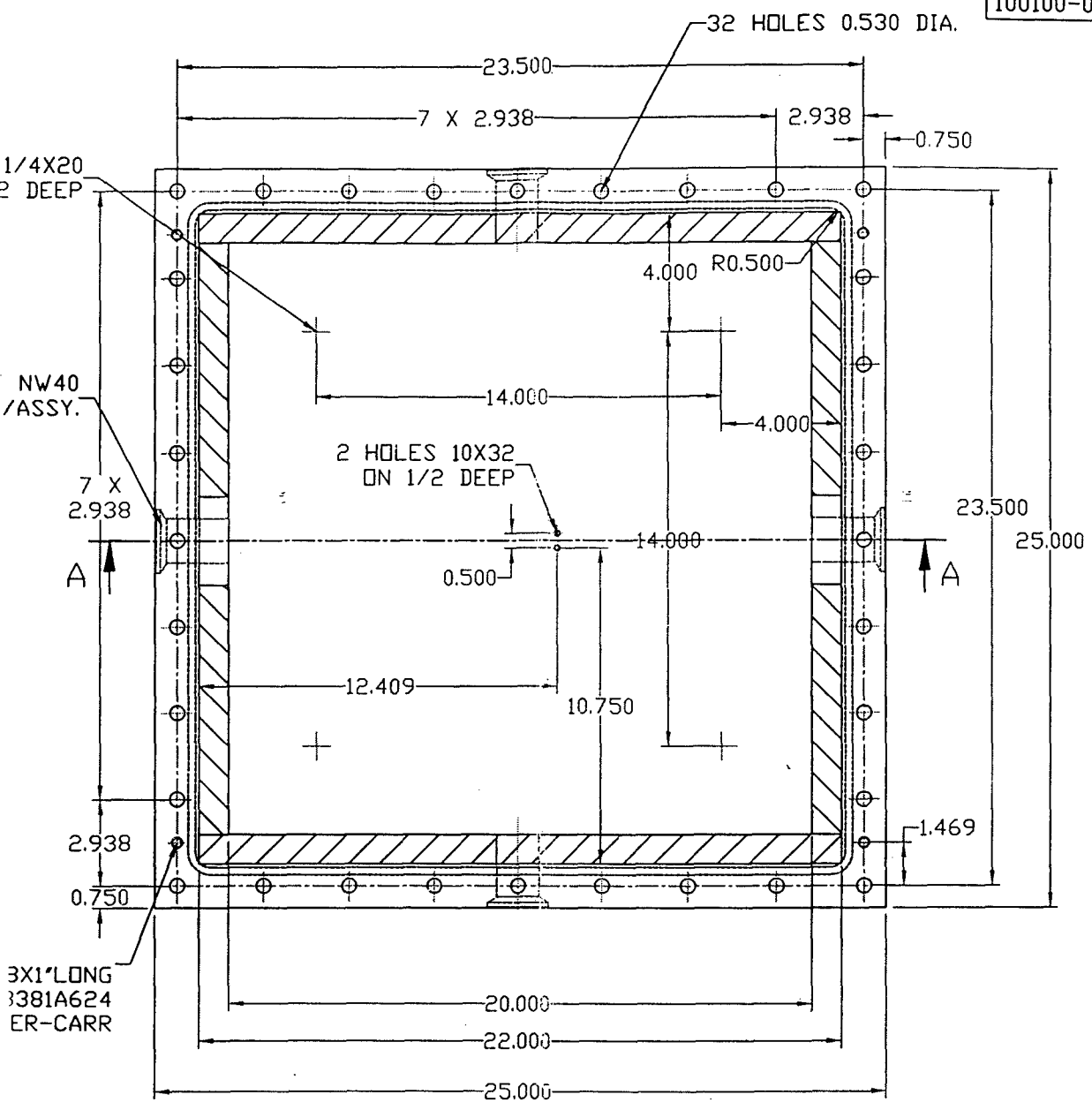

CP	4AUG98	INITIAL RELEASE
By	Date	Ap'd
		Description

Customer		Job Number	
Del#	Qty	Material	
		MATL1	
		MATL2	
		MATL3	

DIMENSIONAL MEDIA ASSOCIATES, INC.
New York, New York

125/ uos
 Break sharp edges

VACUUM CHAMBER

DESIGN #1

Drawn	CP	4AUG98
Check	CP	4AUG98
App'd	JB	4AUG98

Information on this drawing is proprietary and confidential and must not be copied or disclosed without written authorization from Dimensional Media Associates, Inc. This drawing must be returned to Dimensional Media Associates, Inc. immediately on request.

Tolerances Unless Otherwise Noted:
 Whole Nos. and Fractions: ±1/32 Angles ±30'
 .XXX Decimals ±.010 .XX Decimals ±.020

Scale	Drawing Number	Rev
1:1	100100-01	A

G. Cell press mechanical drawing

The following pages contain the mechanical drawings of the hydraulic cell press designed to press the MOE liquid crystal shutter cells down to a uniform thickness.

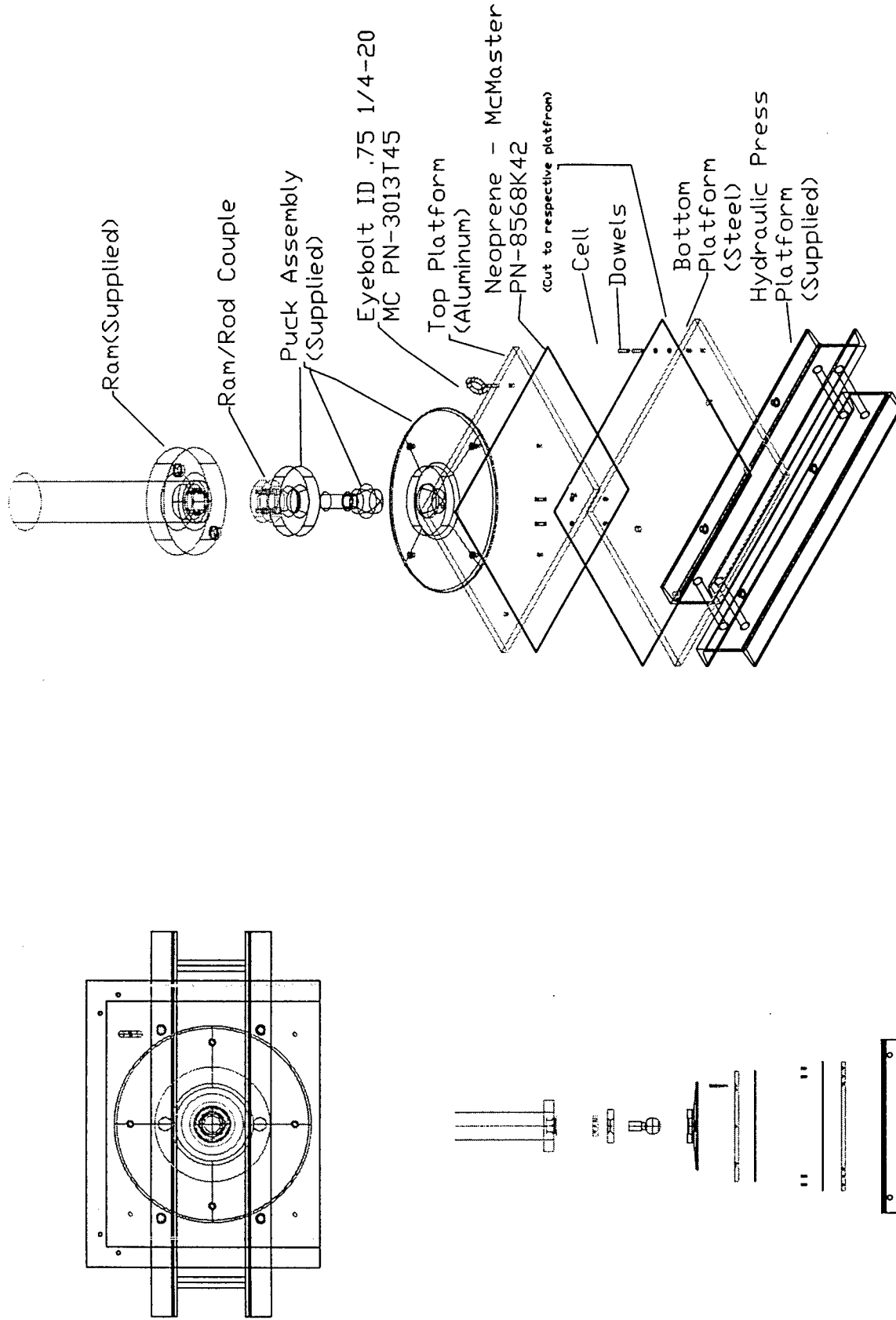

		DIMENSIONAL MEDIA ASSOCIATES, INC.	
Job No. JOBNO	Material	Date CUST	City
Title 1 TITLE1	Title 2 TITLE2	Title 3 TITLE3	Scale SCALE
Drawn DK	Check CHK	Date DATE	Scale SCALE
App'd REL	Date DATE	Title TITLE	Scale SCALE
Description Description			
All information on this drawing is proprietary and confidential and must not be copied or disclosed without written authorization. If you are not the intended recipient, you should not disseminate, distribute or take any action in reliance on the information herein. If you have received this information by mistake, please notify the sender immediately by telephone or return mail. Your cooperation in this matter is appreciated.			
Whole No. and Fraction 3/32			
JAC: December 2010 JAC: December 2010			

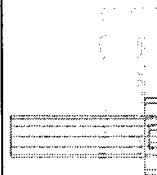
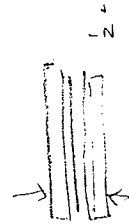
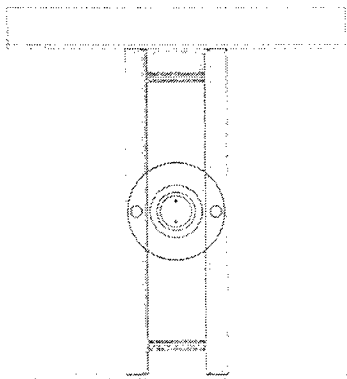
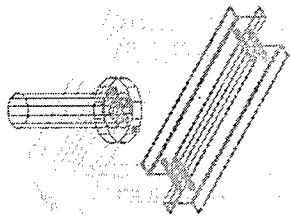

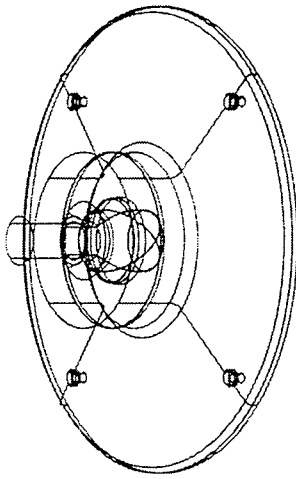
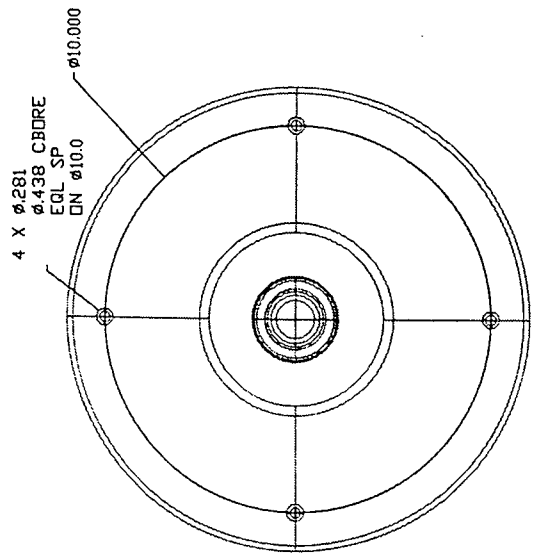

Cut to length

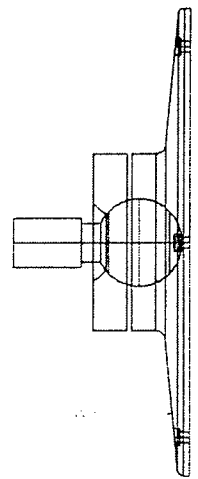
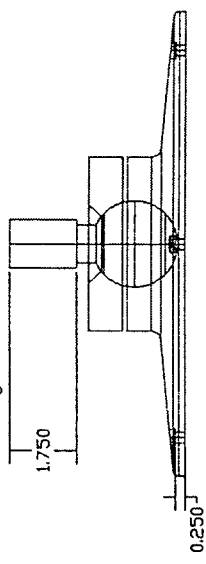

Rev	By	Date	Description

Drill & tap 4 holes.
Cut rod to length.

Customer	Job No	Job Name	Material
CUST			
Date	Qty		
		MAT.1	
		MAT.2	
		MAT.3	

Jobscope: Unions, Distributions, Joints:
Whole Sale and Fractional: 1/16" to 1/2"
JCC Distributor: 2010 JCC Distributor: 2020

Drawn	CHK	ORIGIN	Scale	Drawing Number	Rev
DJL					
Check	CHK	ORIGIN	Scale	Drawing Number	Rev
App'd	REL	DATE	SCALE	10005	

13/ use
PUNCH
TITLES
TITLES

DIMENSIONAL MEDIA ASSOCIATES, INC.

Ø2.750
1.25 - 7 UNC

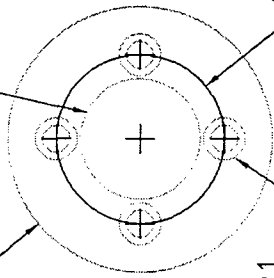

4 X Ø0.281
Ø0.438 CBDR
EQL SP DN Ø1.75

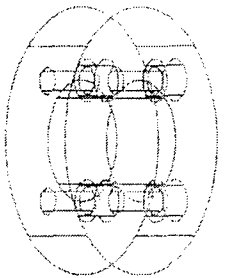

0.750
0.500

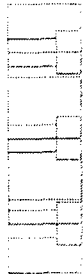
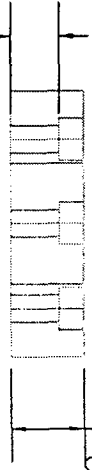

Steel		CUST		JOB NO		MATERIAL	
		DWF					
		CITY					
				STEEL			
				MATL2			
				MATL3			
Rev	By	Description					
<small>All dimensions on this drawing to be produced to tolerance and confirmation and must not be copied or modified without written authorization from Dimensional Media Associates, Inc. All dimensions are to be confirmed unless otherwise noted. The tolerance of Dimensional Media Associates, Inc. is standard unless otherwise noted.</small>							
Whole Nos. and Fractions 1/32				Angular .30			
.001 Decimals .010				.02 Decimals .020			
Drawn		CHK		CRDWT		Scale	
App'g		REL		REL		SCALE	
						1006	
						Drawing Number	
						Rev	

DIMENSIONAL MEDIA ASSOCIATES, INC.
 127 USE
 COUPLER
 TITLES
 TITLES
 Scale
 TITLE2
 TITLE1
 SCALE

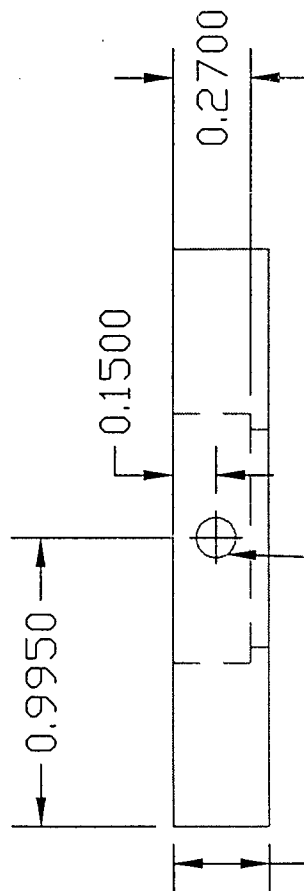
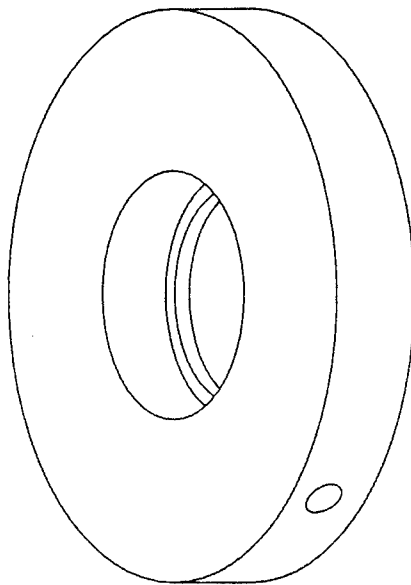
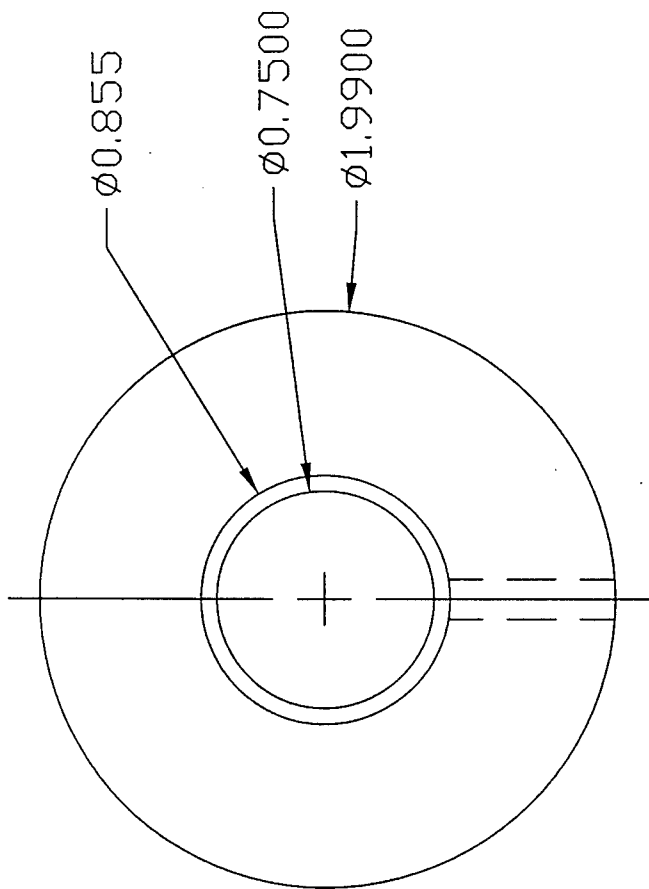

0.3325

Drill & Tap 6-32

Rev	By	Date	Description

All information on this drawing is proprietary and confidential. It is the property of Dimensional Media Associates, Inc. This document must be returned to Dimensional Media Associates, Inc. immediately upon request.

Customer	Job No	Job Name
CUST	JOBNO	Material
Date		
Qty		
	ALUMINIUM	
	MATL2	
	MATL3	

Dimensional Media Associates, Inc.
 10000 S. 10th St., Suite 200
 Tukwila, WA 98148
 Phone: (206) 835-1010
 Fax: (206) 835-1010
 E-Mail: sales@dimensionalmedia.com

DM
 DIMENSIONAL MEDIA ASSOCIATES, INC.
 10000 S. 10th St., Suite 200
 Tukwila, WA 98148

13/1008
 Drawn: DK
 Check: CHK
 App'd: REL

LENMOUNT
 DARPA02
 TITLE:3
 Scale: 1:1
 REVISION: 2-001

H. MOE Driver Schematics

The following pages contain the electronic schematics of the MVD framebuffer electronics.

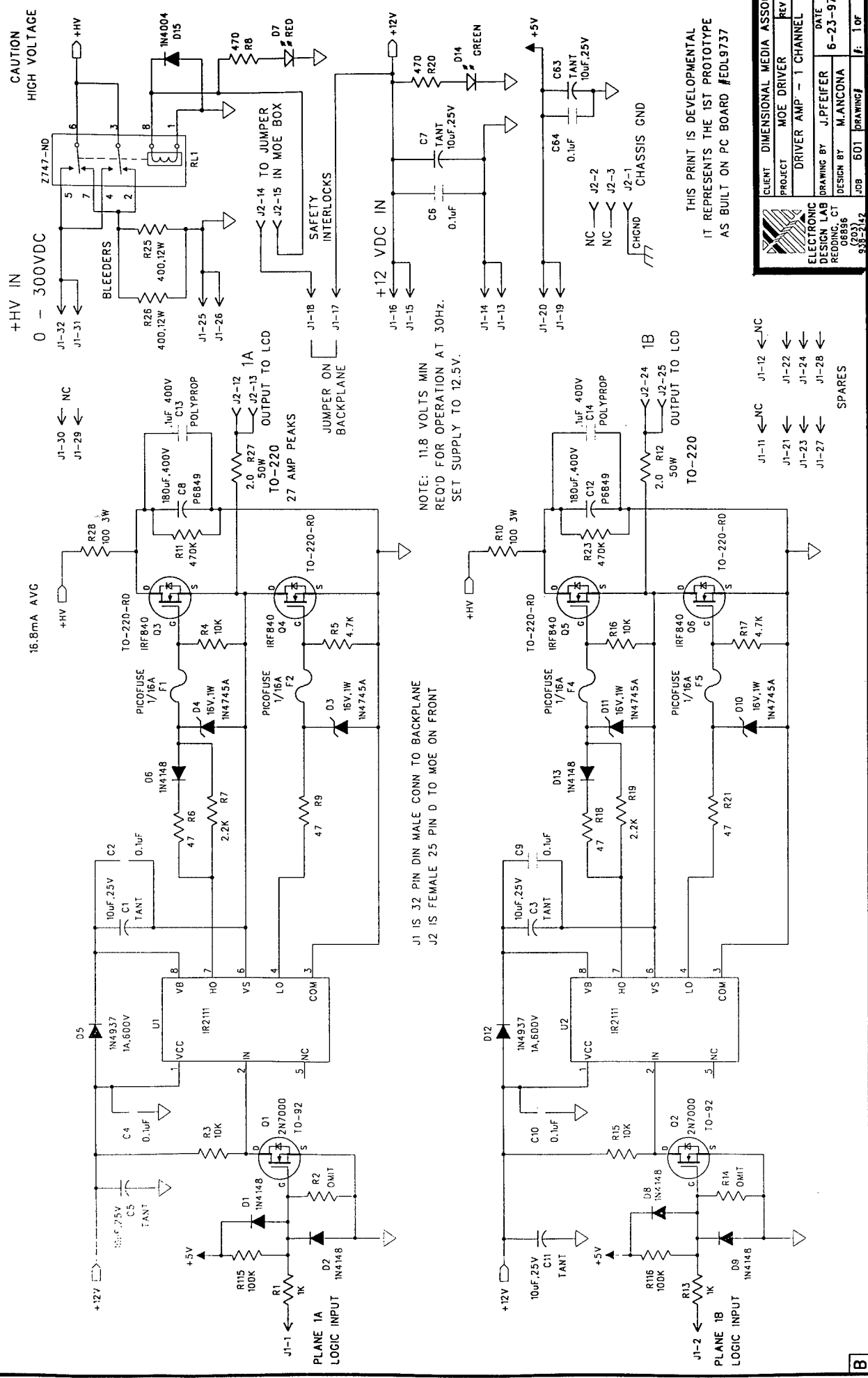

THIS PRINT IS DEVELOPMENTAL
IT REPRESENTS THE 1ST PROTOTYPE
AS BUILT ON PC BOARD #EDL9737

CLIENT	DIMENSIONAL MEDIA ASSOC
PROJECT	MOE DRIVER
DRIVER AMP	- 1 CHANNEL
ELECTRONIC DESIGN LAB	REDDING, CT
DESIGN BY	J. PFEIFER
DATE	6-23-97
JOB	601
REV	1 of 5

NOTE: 11.8 VOLTS MIN
REQ'D FOR OPERATION AT 30HZ.
SET SUPPLY TO 12.5V.

J1 IS 32 PIN DIN MALE CONN TO BACKPLANE
J2 IS FEMALE 25 PIN D TO MOE ON FRONT

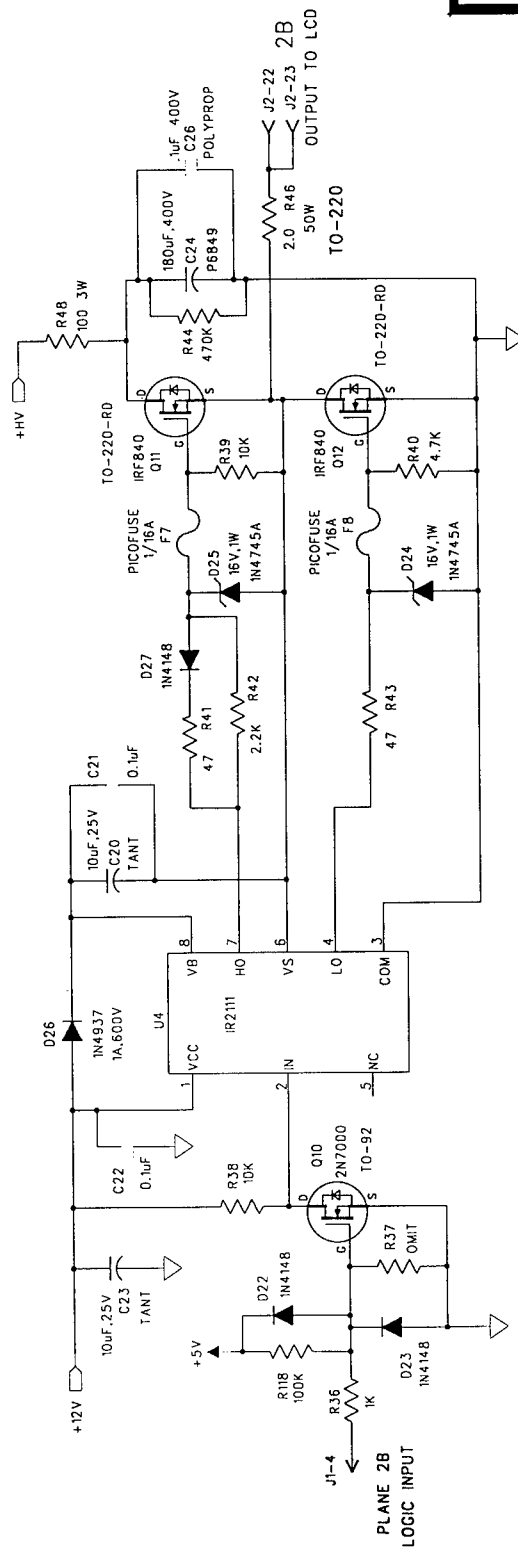
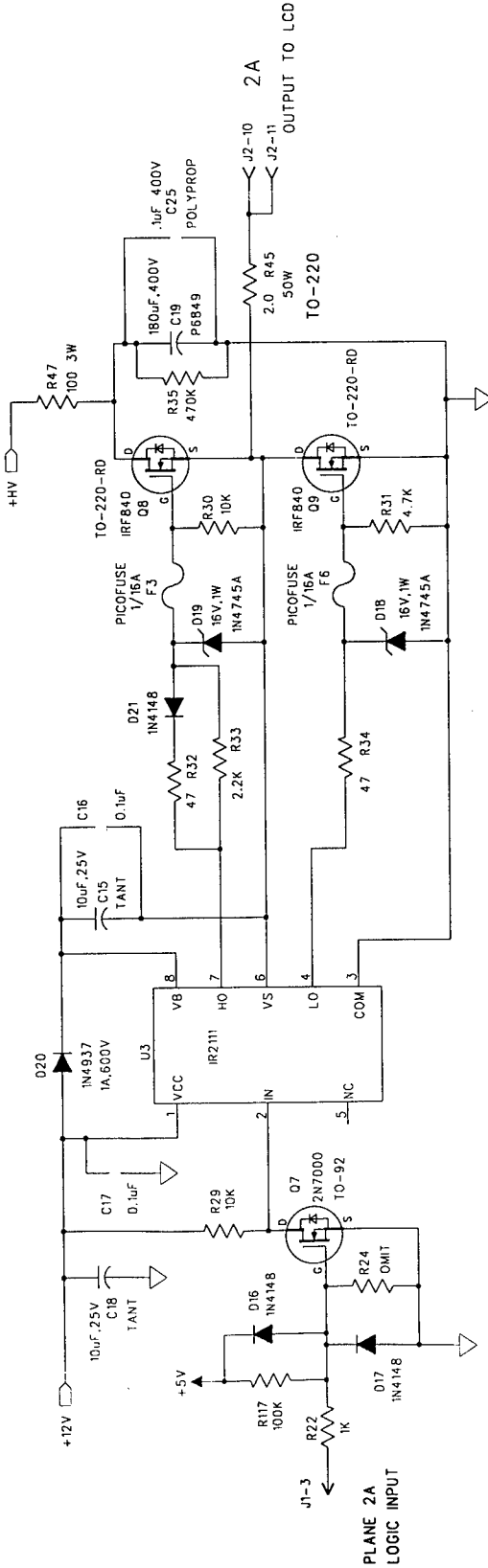

THIS PRINT IS DEVELOPMENTAL
 IT REPRESENTS THE 1ST PROTOTYPE
 AS BUILT ON PC BOARD #EDL9737

CLIENT	DIMENSIONAL MEDIA ASSOC
PROJECT	MOC DRIVER
DESIGN LAB	DRIVER AMP - 1 CHANNEL
REDDING, CT	DRAWING BY J.PFEIFER
06896	DESIGN BY M.ANCONA
(203)	JOB 601
938-242	DRAWING #
	DATE 6-23-97
	REV
	1 OF 5

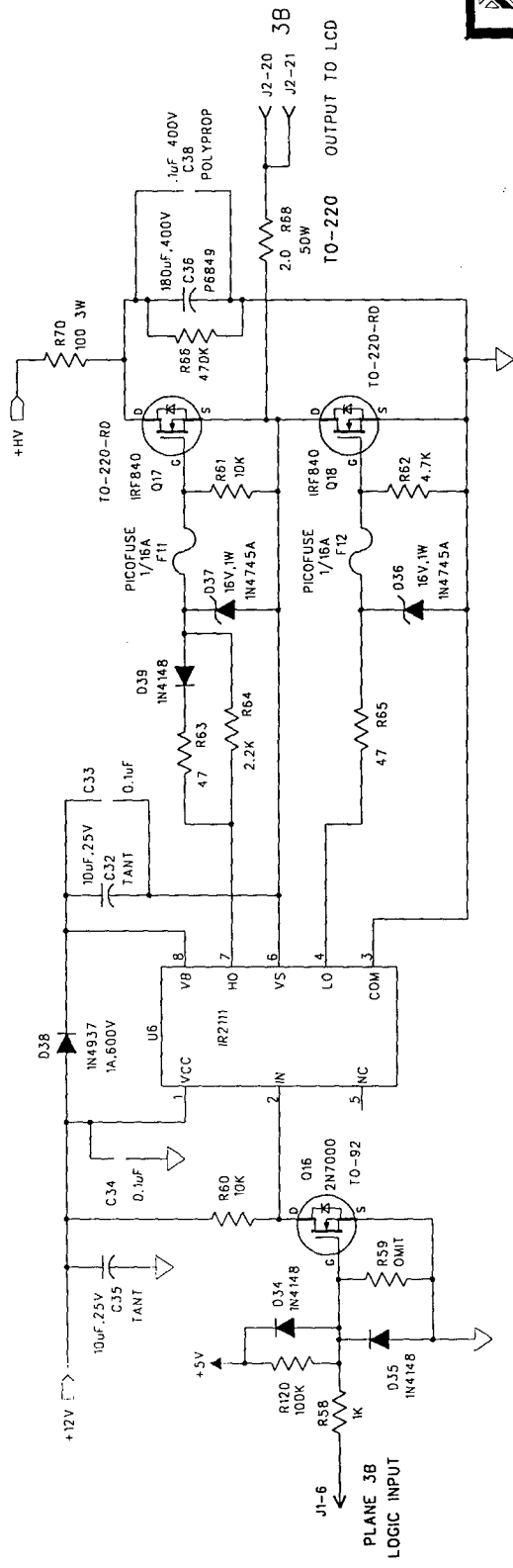
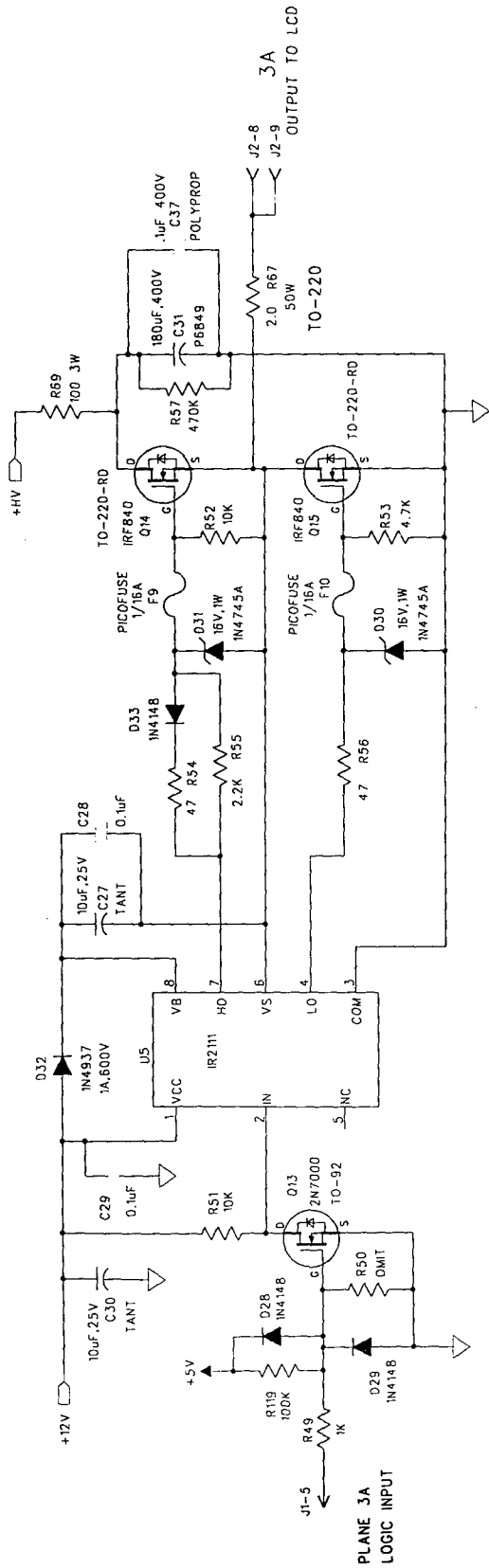

THIS PRINT IS DEVELOPMENTAL
IT REPRESENTS THE 1ST PROTOTYPE
AS BUILT ON PC BOARD #EOL9737

CLIENT	DIMENSIONAL MEDIA ASSOC
PROJECT	MOE DRIVER
REVISION	REV
DRAWING BY	J.PFEIFER
DESIGN BY	M.ANCONA
DATE	6-23-97
DESIGN LAB	06856 C1
JOB	601 DRAWING#
	938-21x2
	P. 3 of 5

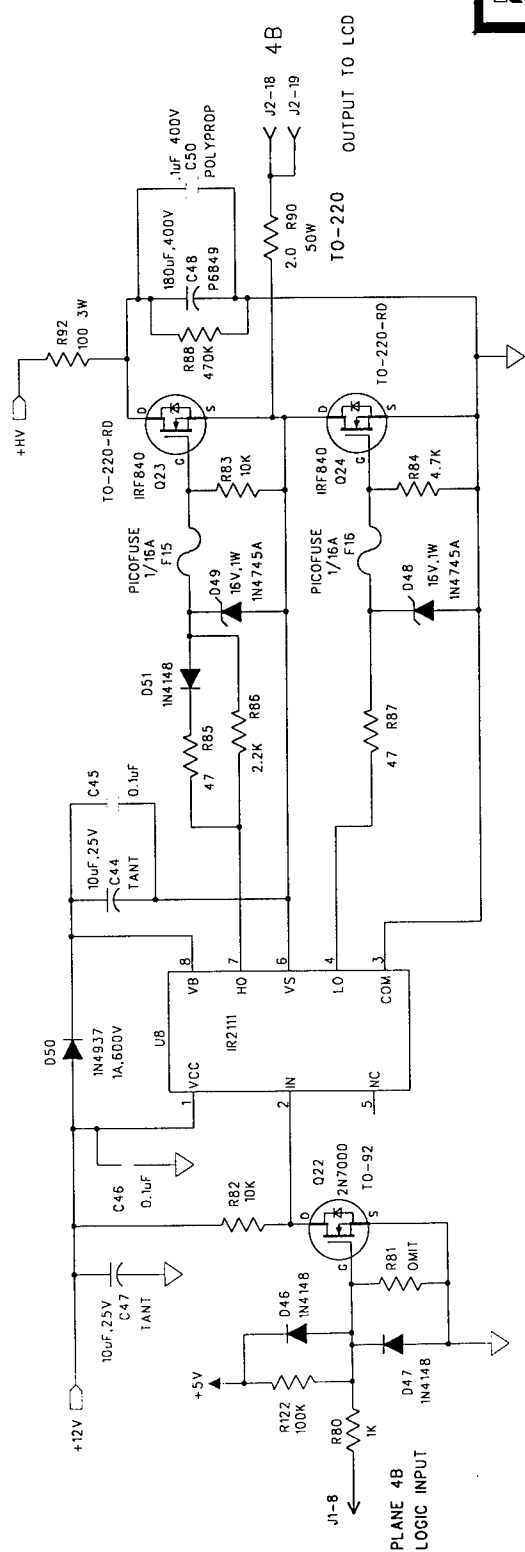
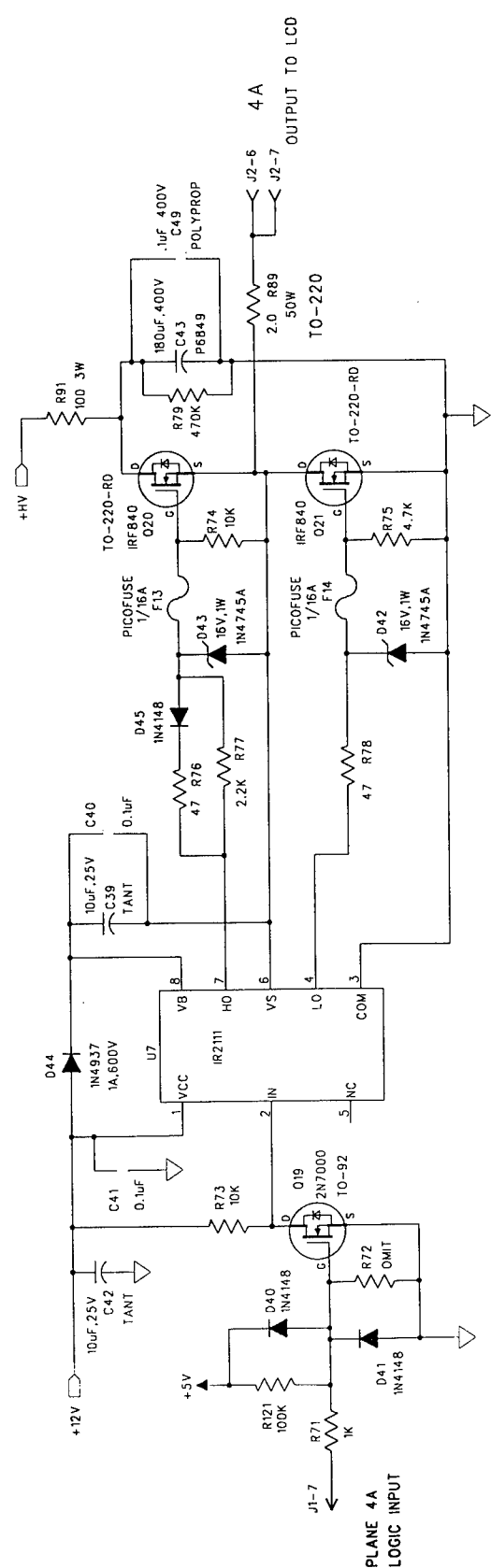

THIS PRINT IS DEVELOPMENTAL
IT REPRESENTS THE 1ST PROTOTYPE
AS BUILT ON PC BOARD #EDL9737

CLIENT	DIMENSIONAL MEDIA ASSOC
PROJECT	MOE DRIVER
DRIVER AMP	- 1 CHANNEL
DRAWING BY	J.PFEIFER
DESIGN BY	M.ANCONA
JOB	601 DRAWING#
DATE	6-23-97
REV	F: 4of 5

THIS PRINT IS DEVELOPMENTAL
IT REPRESENTS THE 1ST PROTOTYPE
AS BUILT ON PC BOARD #EDL9737

CLIENT	DIMENSIONAL MEDIA ASSOC
PROJECT	MOE DRIVER
DRIVER AMP	~ 1 CHANNEL
DESIGN BY	J.PFEIFER
JOB	601
DATE	6-23-97
DESIGNING	M.ANCONA
DRAWING #	9382142
#	5 OF 5

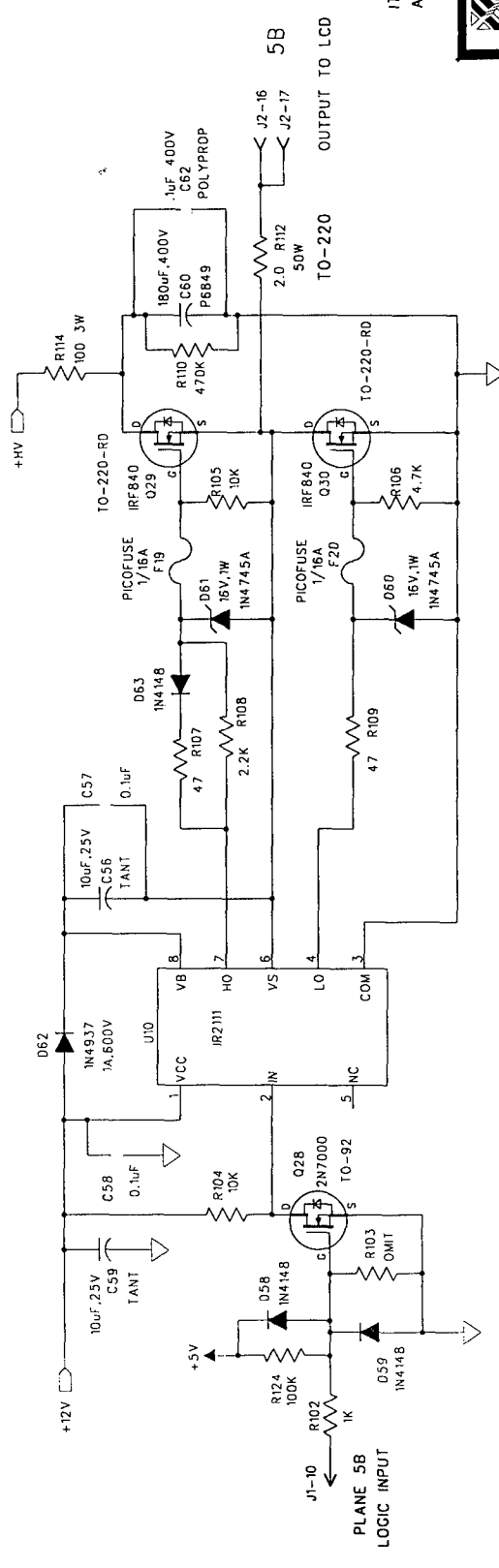
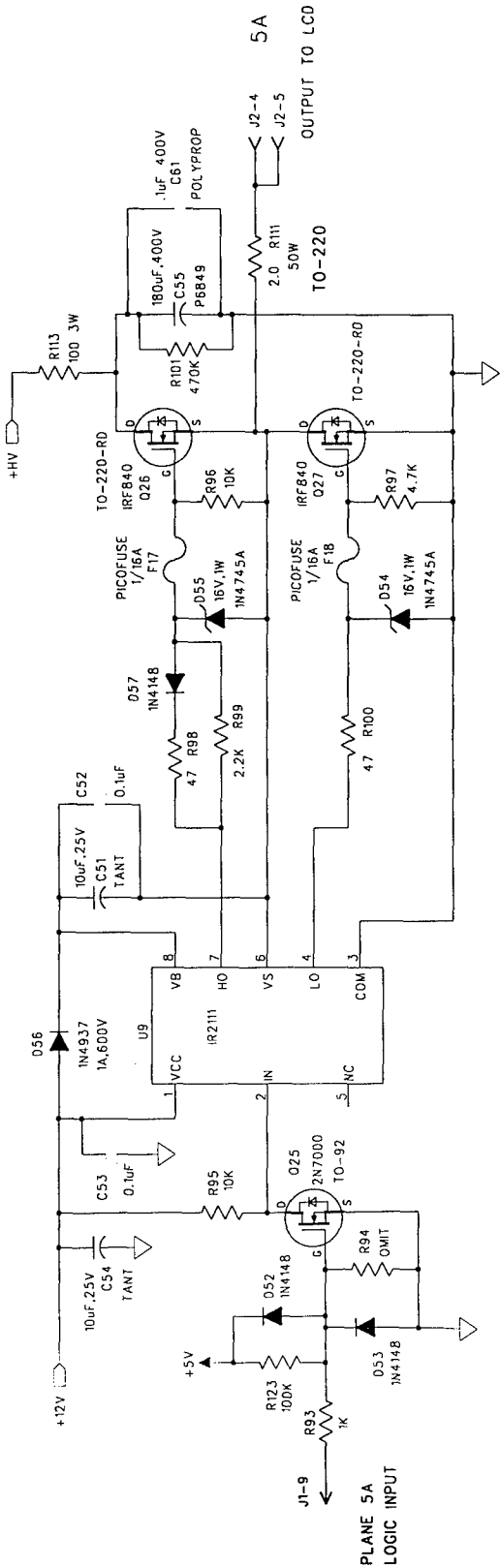

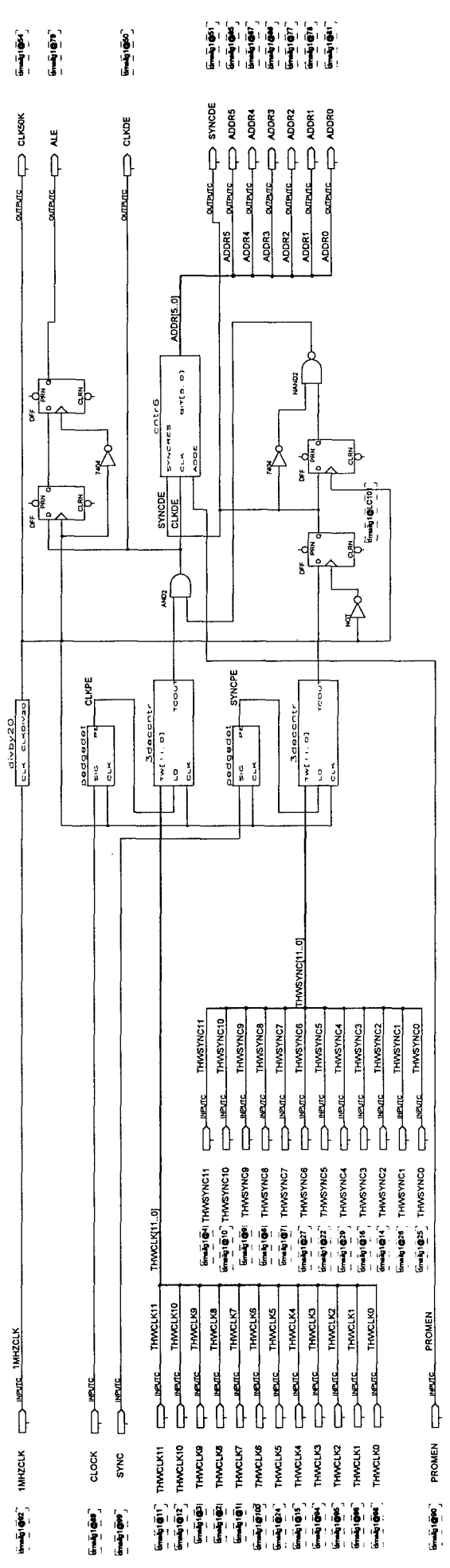

TITLE	LCD DRIVE ELECTRONICS FOR MOE
COMPANY	Dimensional Media Associates
DESIGNER	Electronics Design Lab
SIZE	D
DATE	10/06/81
REV	A
SHEET	142 OF 6

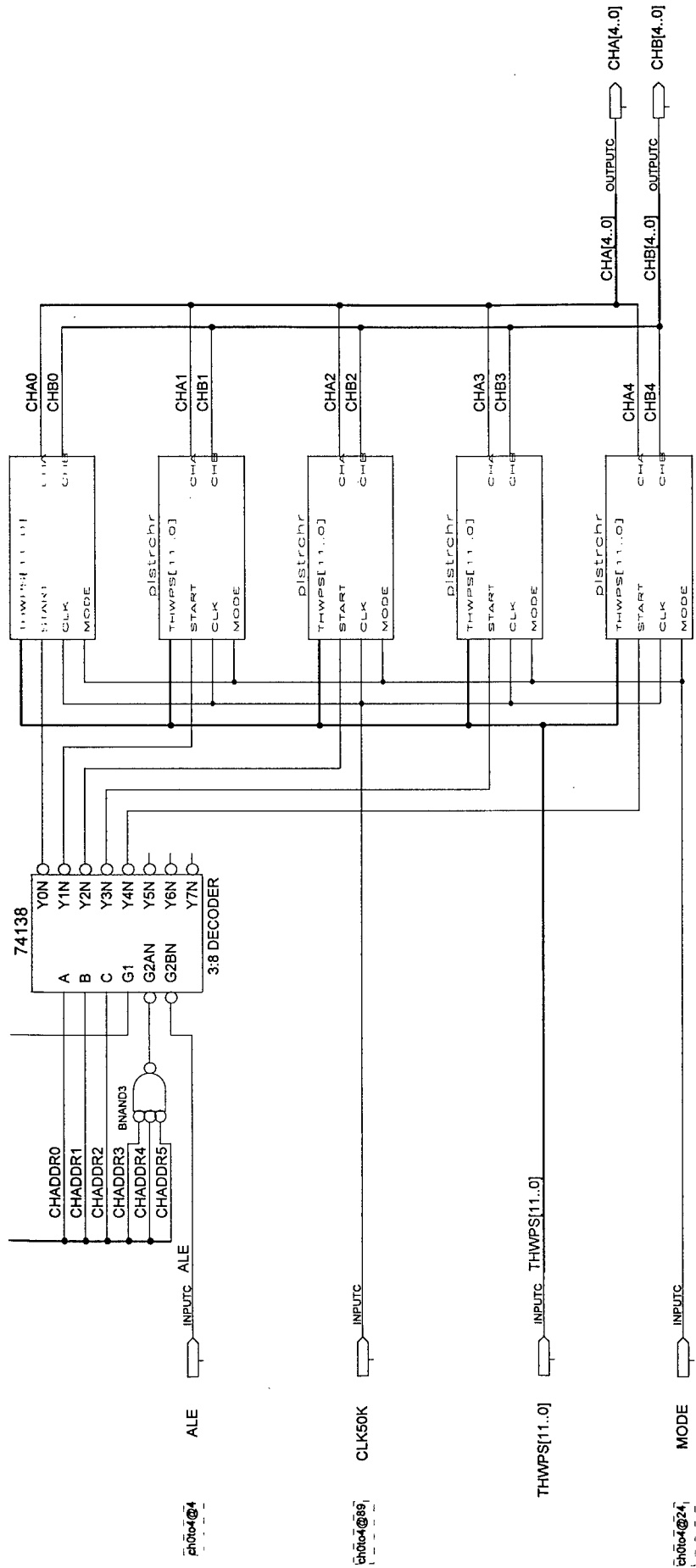

TITLE LCD DRIVER ELECTRONICS FOR MOE			
COMPANY Dimensional Media Associates			
DESIGNER Electronic Design Lab			
SIZE C	NUMBER	Channels 0 to 4	REV A
DATE 9:39a	6-26-1997	SHEET 1	OF 3

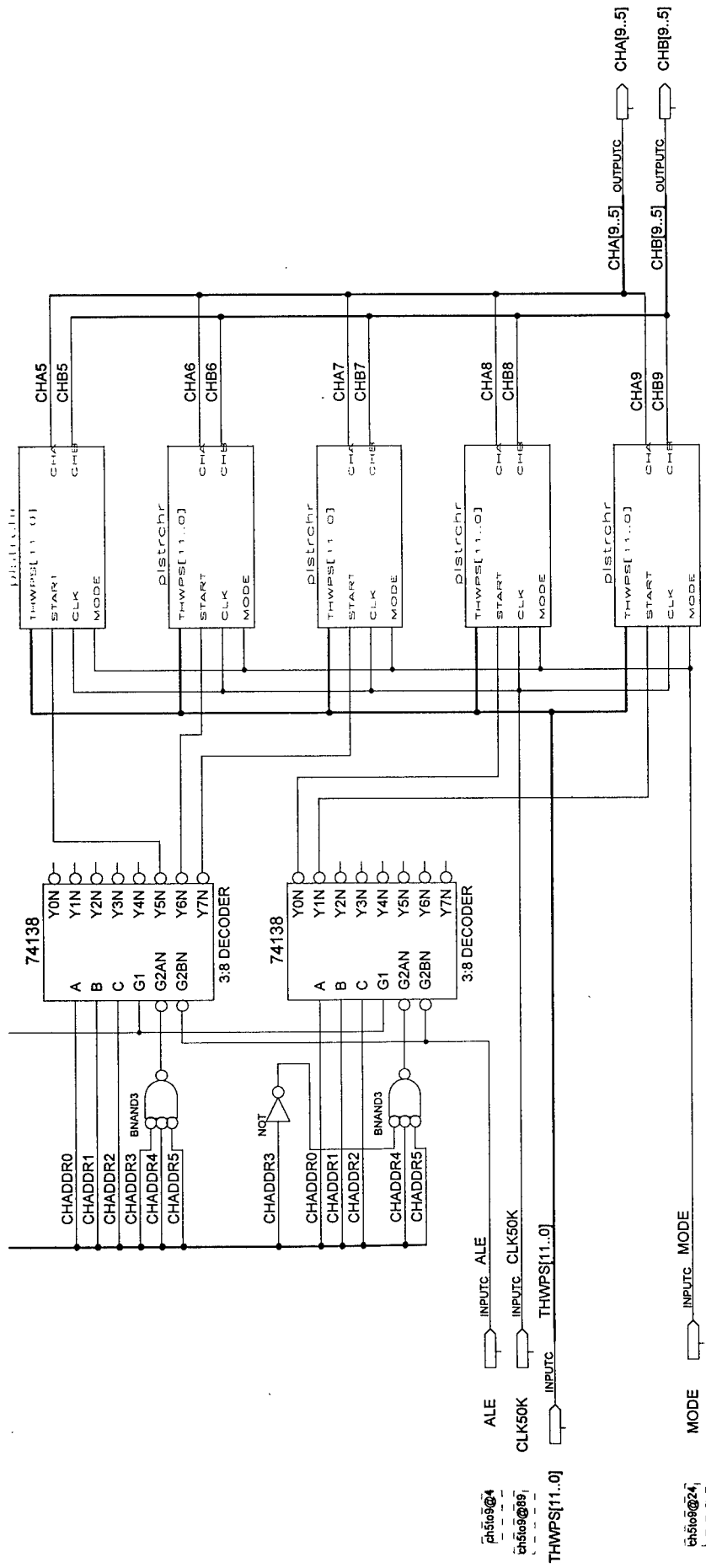

TITLE	LCD DRIVER ELECTRONICS FOR MOE		
COMPANY	Dimensional Media Associates		
DESIGNER	Electronic Design Lab		
SIZE	C	NUMBER	Channels 5 to 9
DATE	10:00a	REV	A
	6-26-1997	SHEET	1 of 3

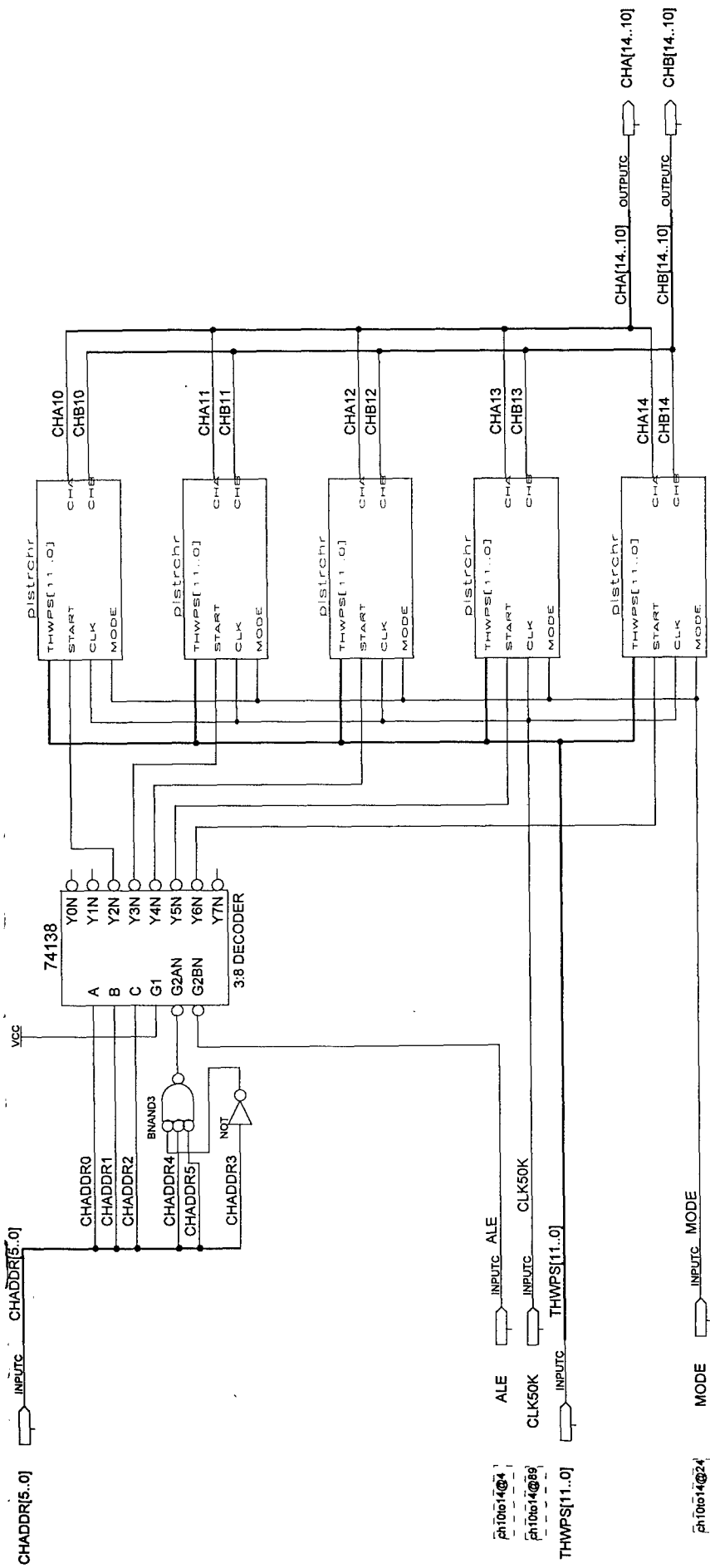

TITLE				LCD DRIVER ELECTRONICS FOR MOE			
COMPANY				Dimensional Media Associates			
DESIGNER				Electronic Design Lab			
SIZE	C	NUMBER	Channels 10 to 14	REV	A		
DATE	10:22a	6-26-1997	SHEET	1	OF	3	

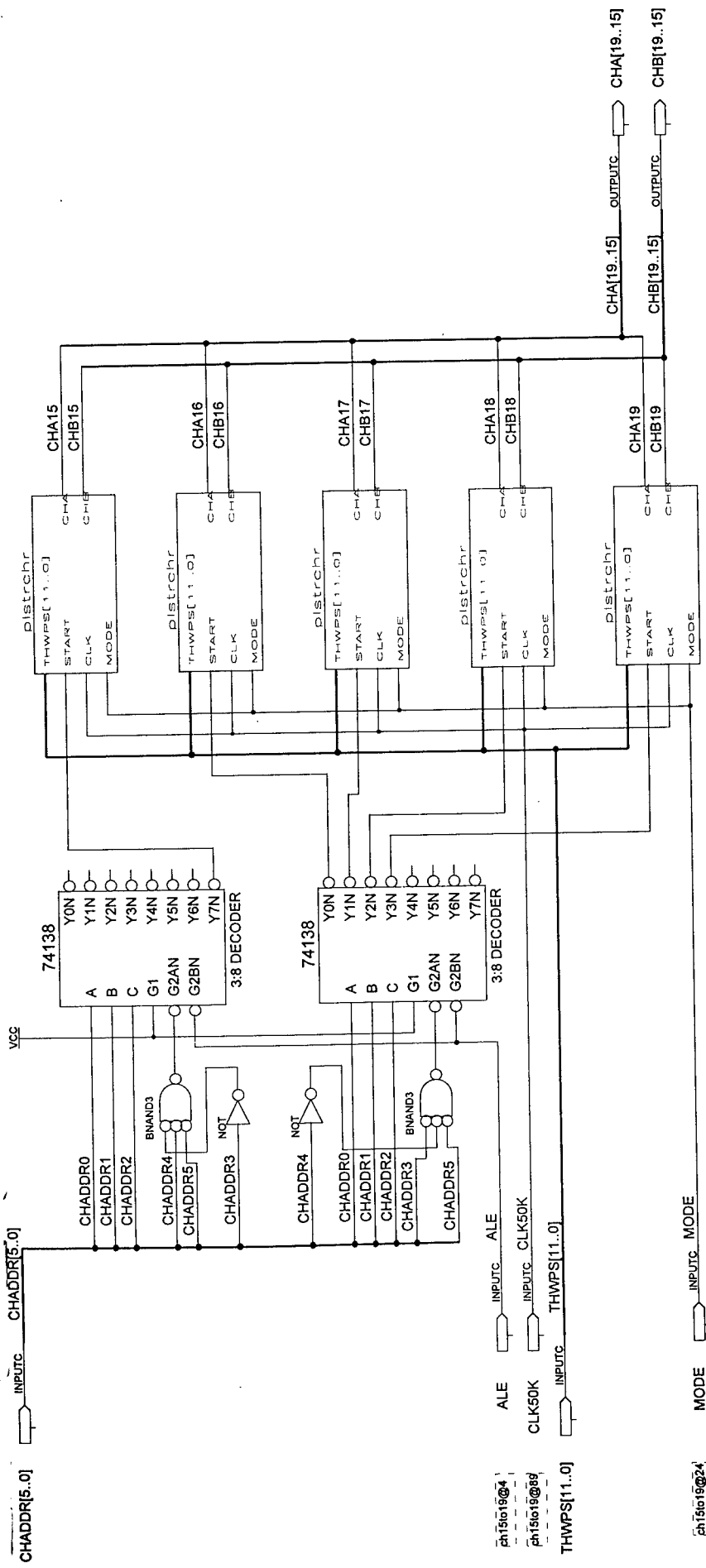

TITLE				LCD DRIVER ELECTRONICS FOR MOE			
COMPANY				Dimensional Media Associates			
DESIGNER				Electronic Design Lab			
SIZE	C	NUMBER	Channels 15 to 19	REV	A		
DATE	10:27a	6-26-1997	SHEET	1	OF	3	

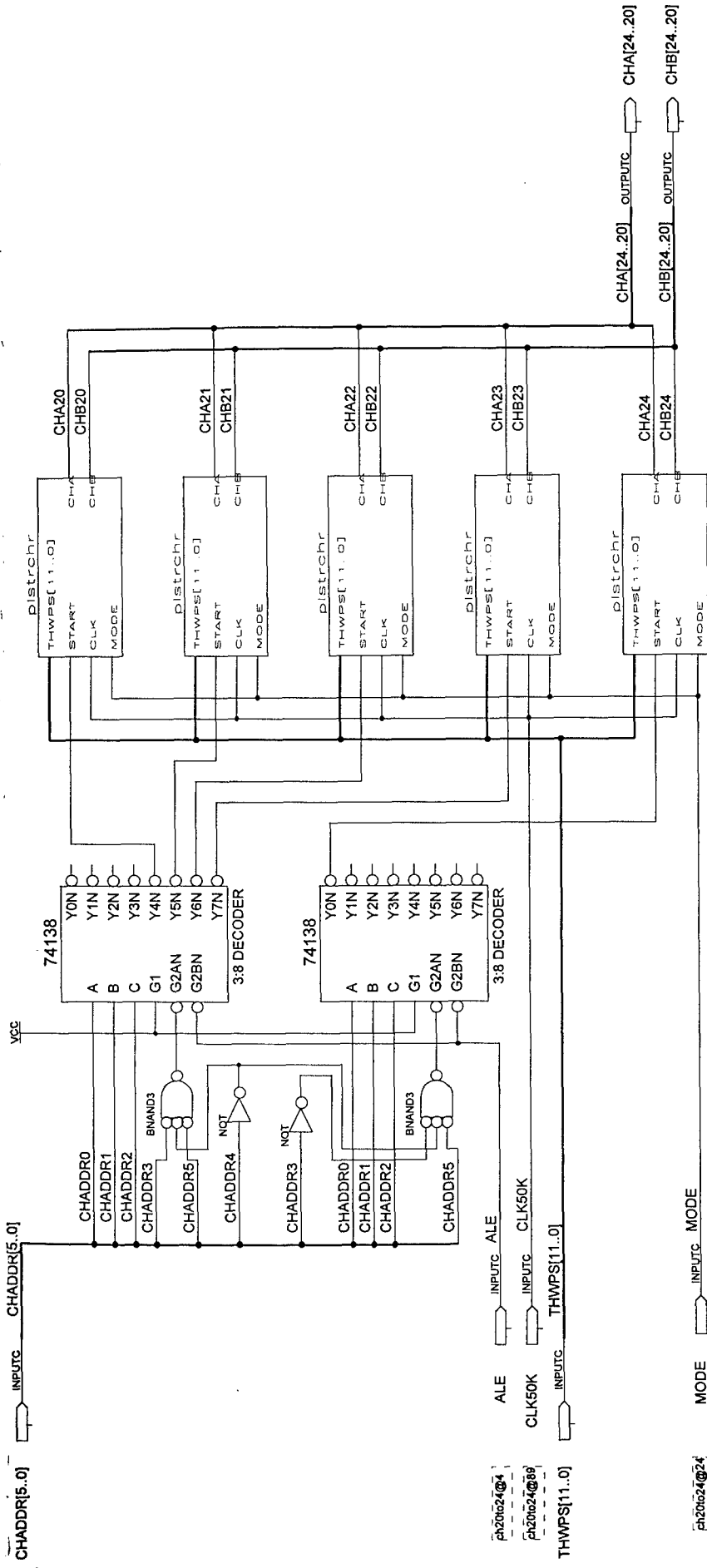

TITLE	LCD DRIVER ELECTRONICS FOR MOE		
COMPANY	Dimensional Media Associates		
DESIGNER	Electronic Design Lab		
SIZE	C	NUMBER	Channels 20 to 24
DATE	10:29a	REV	A
		SHEET	1 OF 3

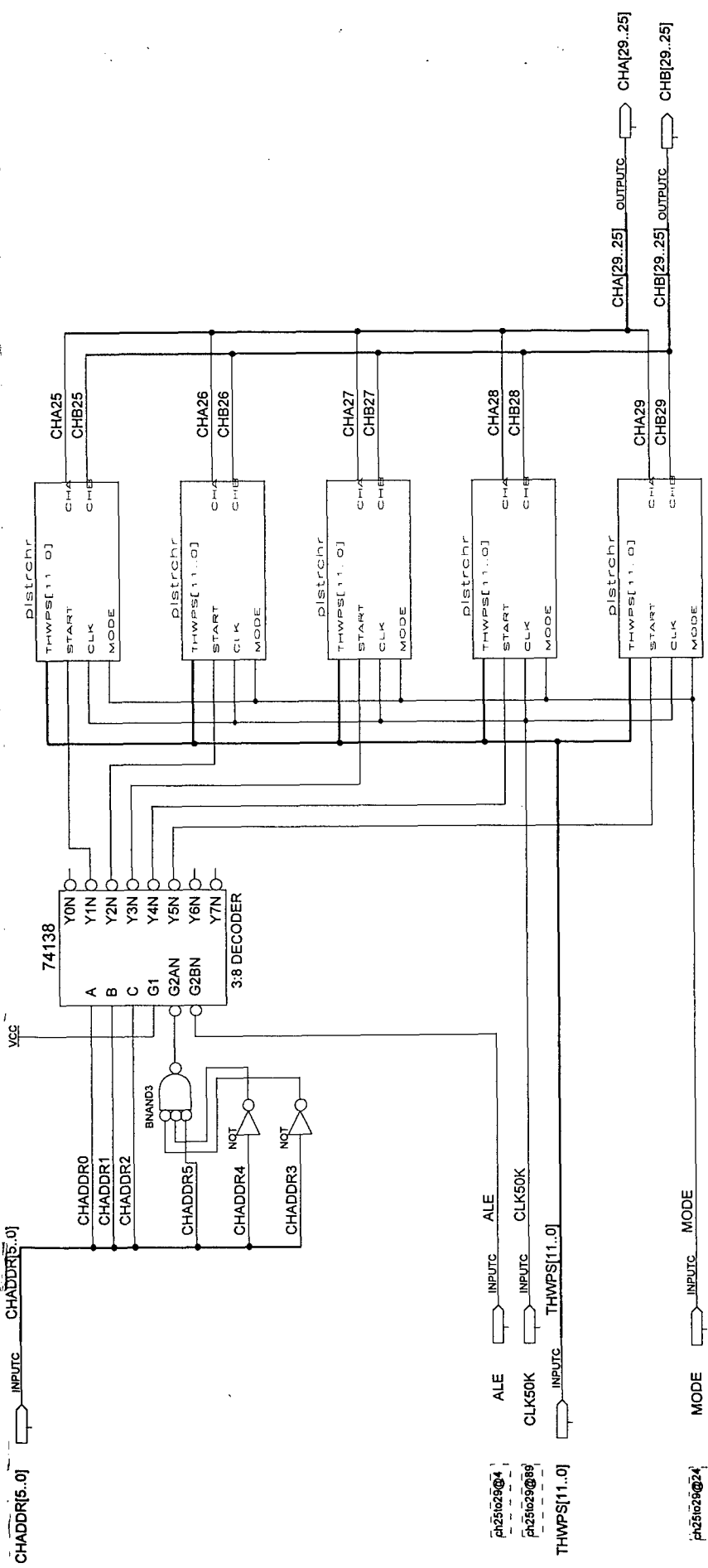

TITLE		LCD DRIVER ELECTRONICS FOR MOE	
COMPANY		Dimensional Media Associates	
DESIGNER		Electronic Design Lab	
SIZE	NUMBER	Channels 25 to 29	REV A
DATE	10:37a 6-26-1997	SHEET	1 OF 3

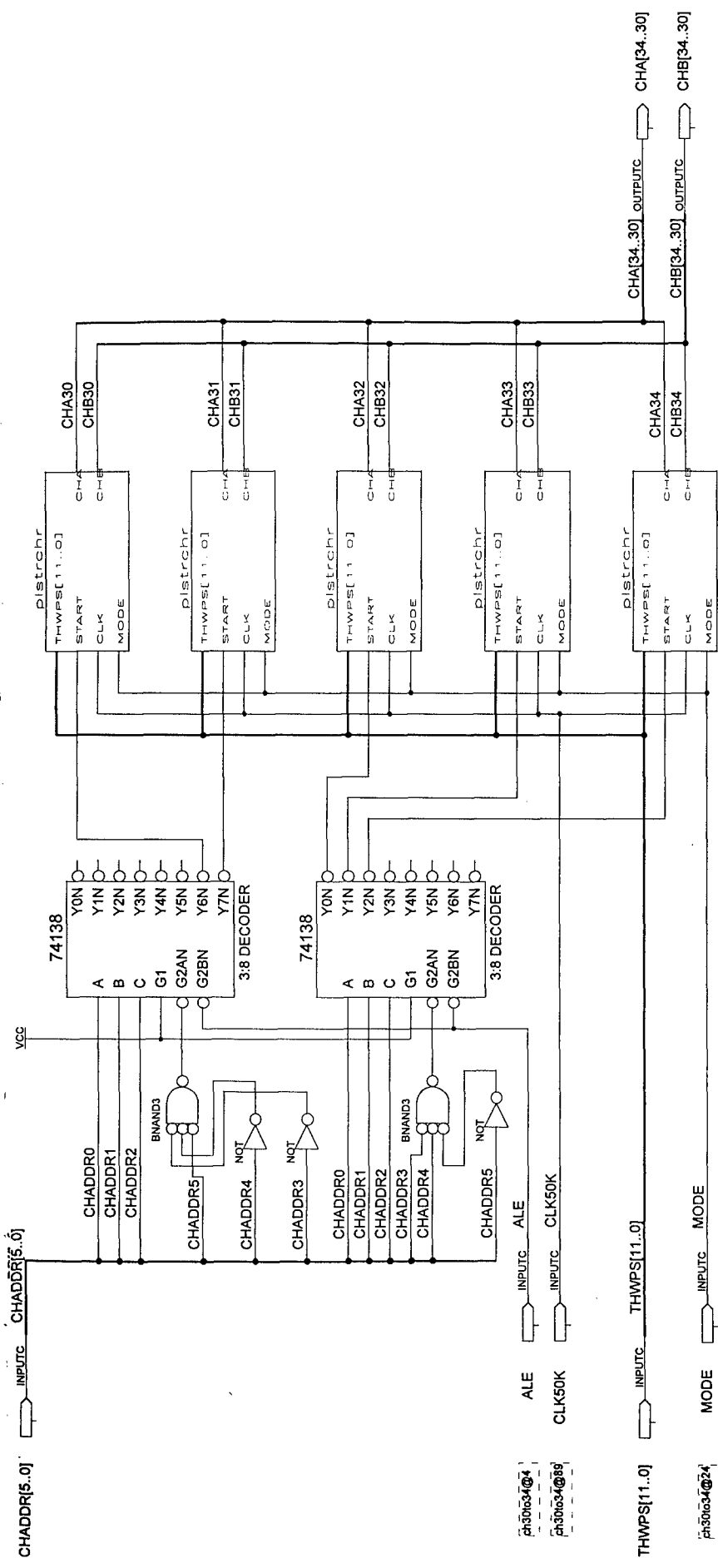

TITLE				LCD DRIVER ELECTRONICS FOR MOE			
COMPANY				Dimensional Media Associates			
DESIGNER				Electronic Design Lab			
SIZE	C	NUMBER	Channels 30 to 34	REV	A		
DATE	10:42a	6-26-1997	SHEET	1	OF	3	

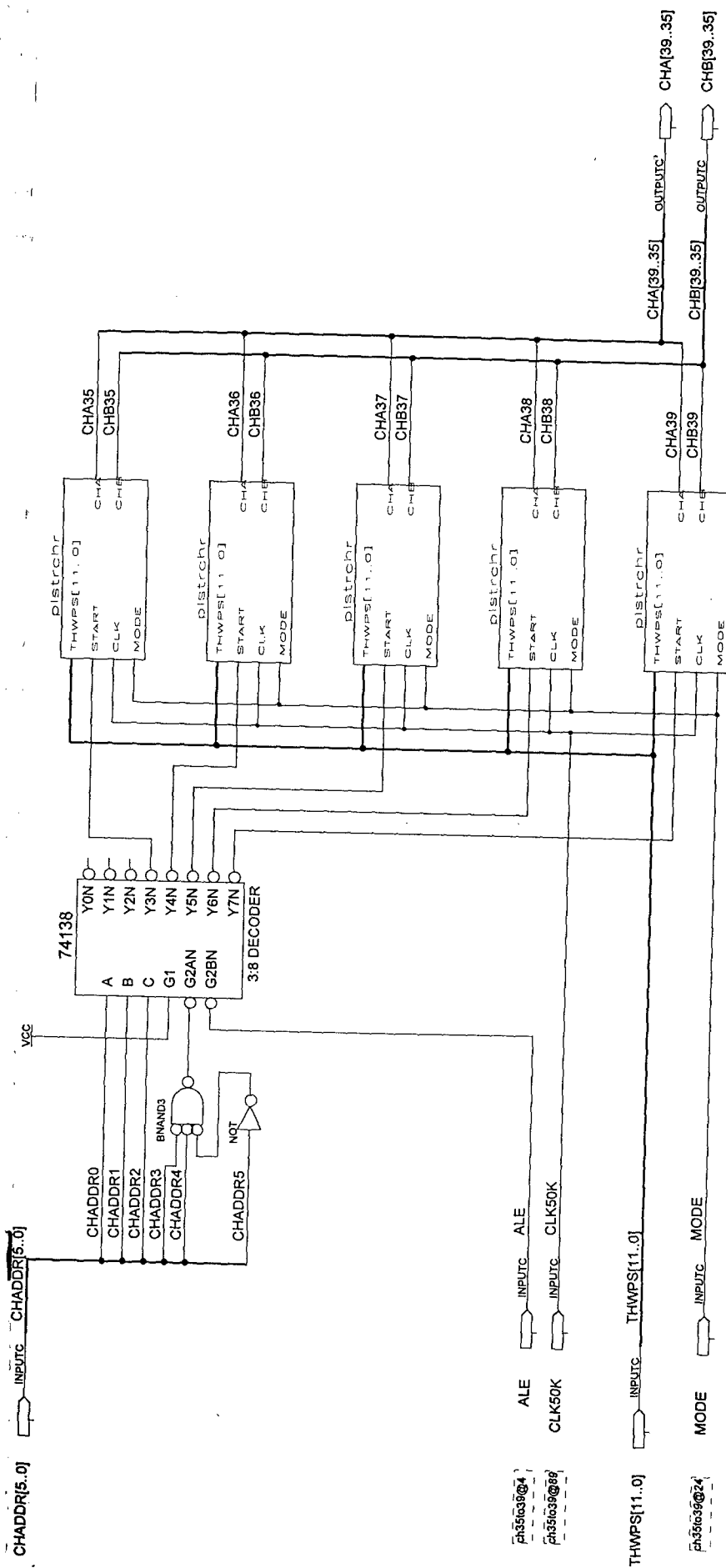

TITLE	LCD DRIVER ELECTRONICS FOR MOE		
COMPANY	Dimensional Media Associates		
DESIGNER	Electronic Design Lab		
SIZE	C	NUMBER	Channels 34 to 39
DATE	10:58a	REV	A
		SHEET	1 OF 2

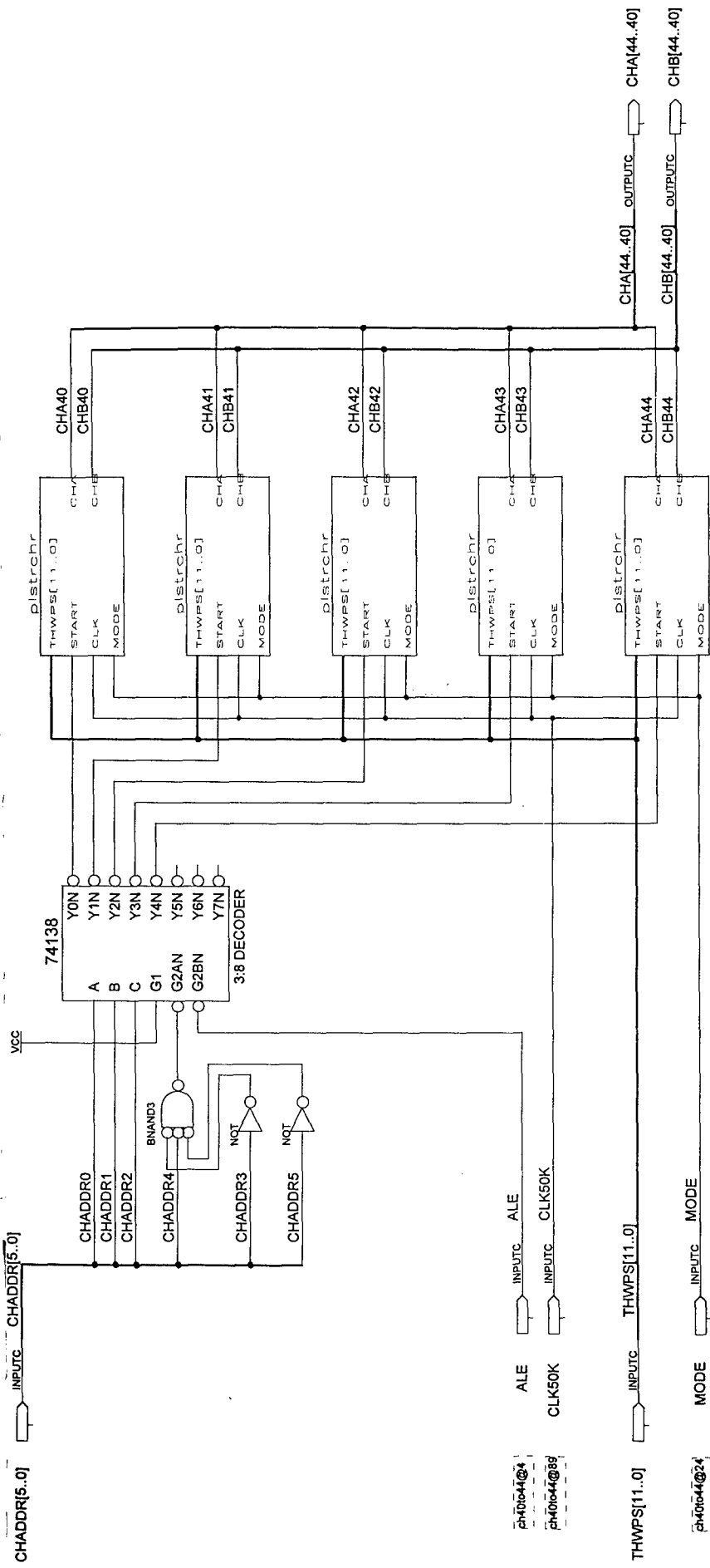

TITLE	LCD DRIVER ELECTRONICS FOR MOE		
COMPANY	Dimensional Media Associates		
DESIGNER	Electronic Design Lab		
SIZE	C	NUMBER	Channels 40 to 44
DATE	11:03a	REV	A
	6-26-1997	SHEET	1 OF 3

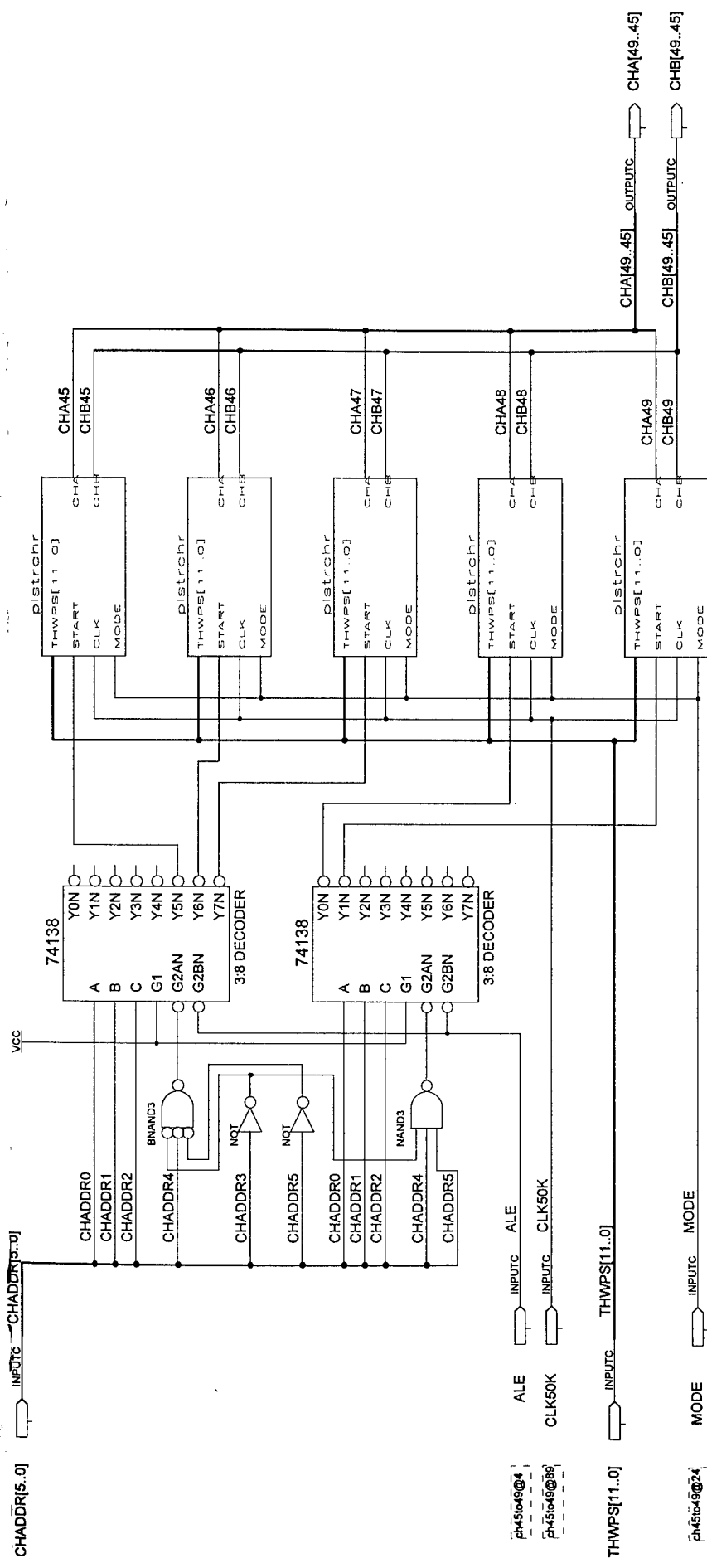

TITLE				LCD DRIVER ELECTRONICS FOR MOE			
COMPANY				Dimensional Media Associates			
DESIGNER				Electronic Design Lab			
SIZE	C	NUMBER	Channels 45 to 49	REV	A		
DATE	11:08a	6-26-1997	SHEET	1	OF	3	

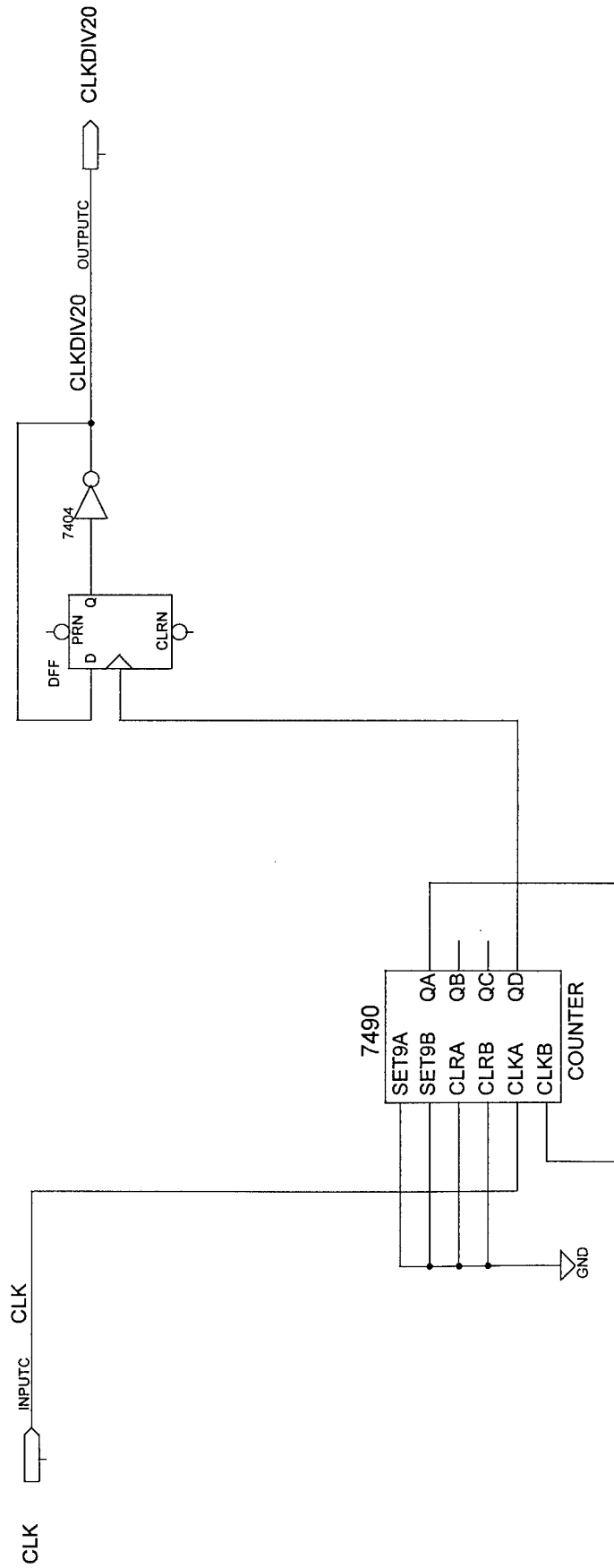

TITLE	LCD DRIVE ELECTRONICS FOR MOE				
COMPANY	Dimensional Media Associates				
DESIGNER	Electronic Design Lab				
SIZE	B	NUMBER	Divide by 20	REV	A
DATE	10:45p 10-27-1997			SHEET	3 OF 6

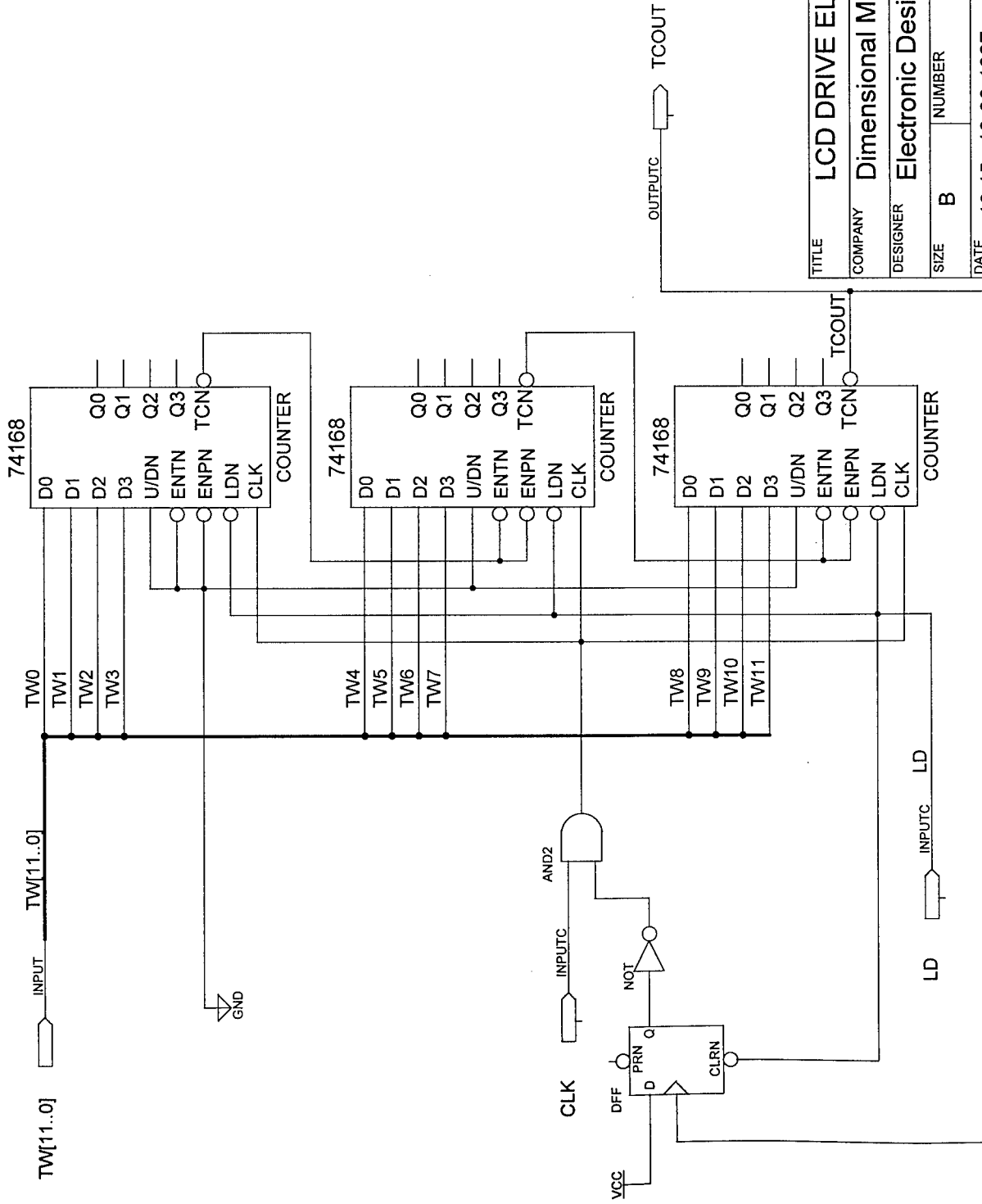

TITLE				LCD DRIVE ELECTRONICS FOR MOE			
COMPANY				Dimensional Media Associates			
DESIGNER				Electronic Design Lab			
SIZE	B	NUMBER	3	Decade counter	REV	A	
DATE	10:15a 10-30-1997		SHEET	3	OF	3	

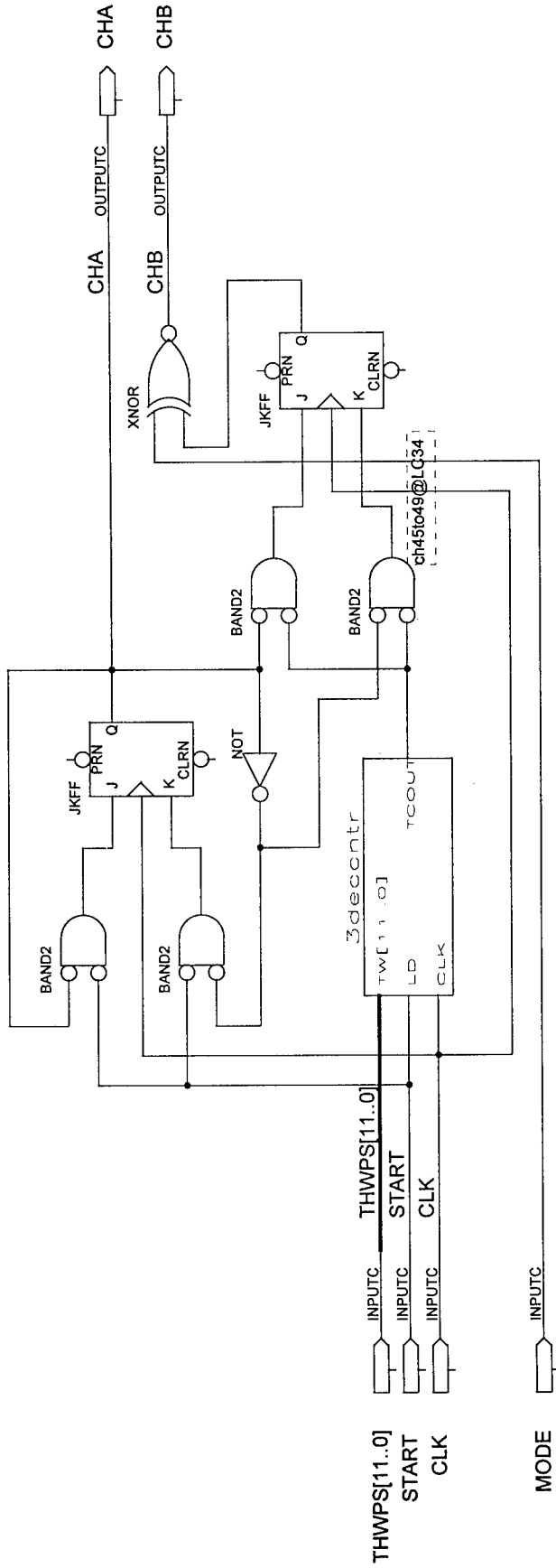

TITLE				LCD DRIVE ELECTRONICS FOR MOE			
COMPANY				Dimensional Media Associates			
DESIGNER				Electronic Design Lab			
SIZE	B	NUMBER	Output Logic	REV	A	SHEET	2 OF 3
DATE				10:01a 6-26-1997			

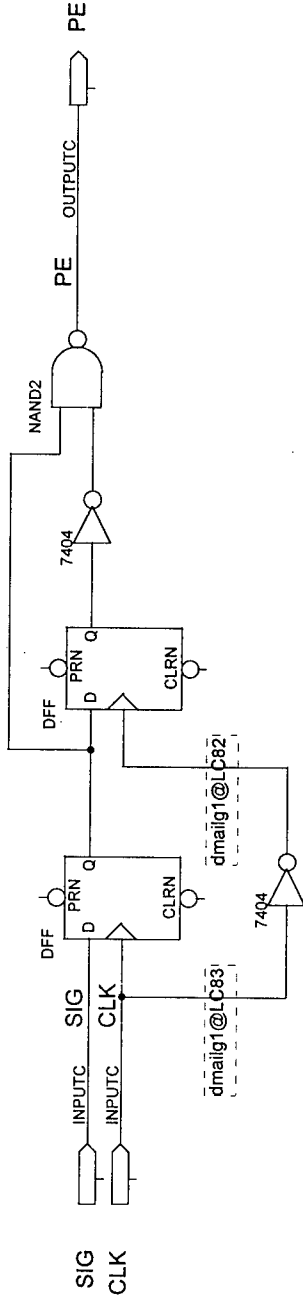

TITLE				LCD DRIVE ELECTRONICS FOR MOE			
COMPANY				Dimensional Media Associates			
DESIGNER				Electronics Design Lab			
SIZE	B	NUMBER	pos edge detector	REV	A		
DATE	3:55p 5-18-2000		SHEET	4	OF	6	

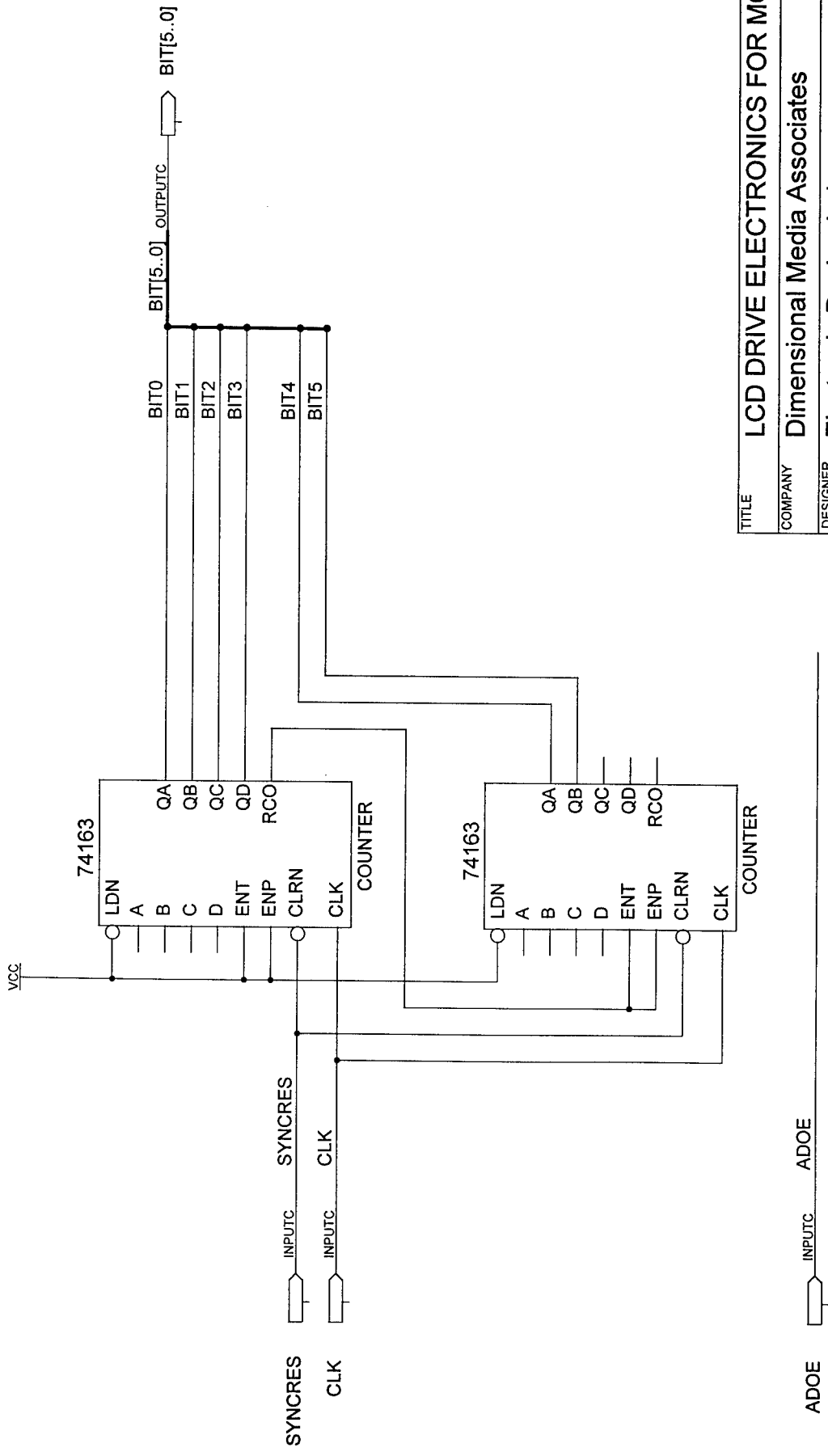

TITLE				LCD DRIVE ELECTRONICS FOR MOE			
COMPANY				Dimensional Media Associates			
DESIGNER				Electronic Design Lab			
SIZE	B	NUMBER	6 bit counter	REV	A		
DATE	10:05a 10-31-1997		SHEET	6	OF	6	

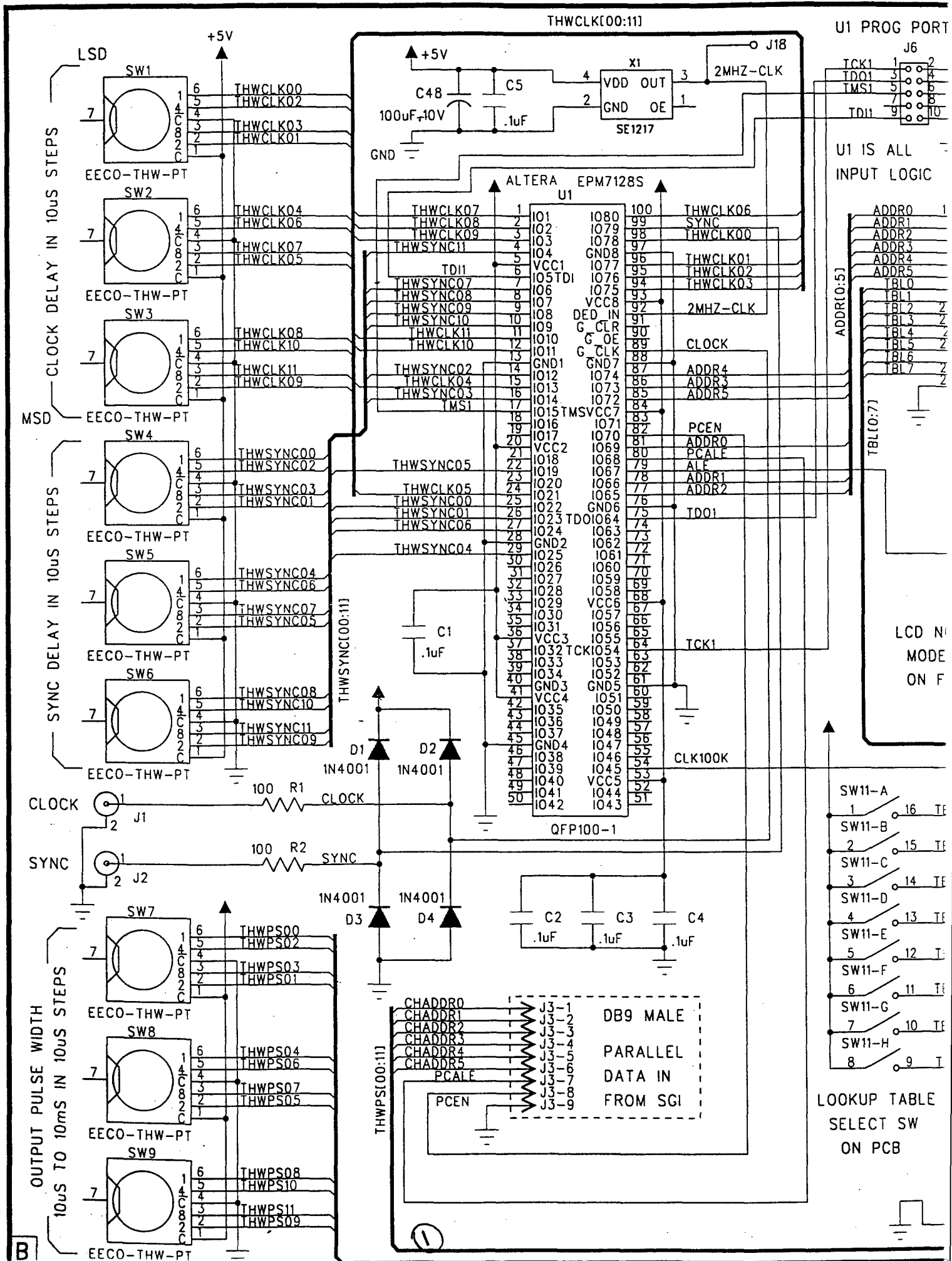

U1 PROG PORT

1ST UNIT DELIVERED
HAS JUMPERS IN PROM SOCKET
ADD TO D00, ETC

U2 HAS 5 PULSE WIDTH CKTS
AND SELECT LOGIC
(CH25 TO CH29)

U1 IS ALL
INPUT LOGIC

LOOK UP TABLE

U3 IN PROM

ALTERA
EPM7128S

U2

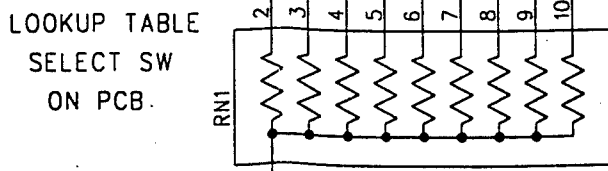
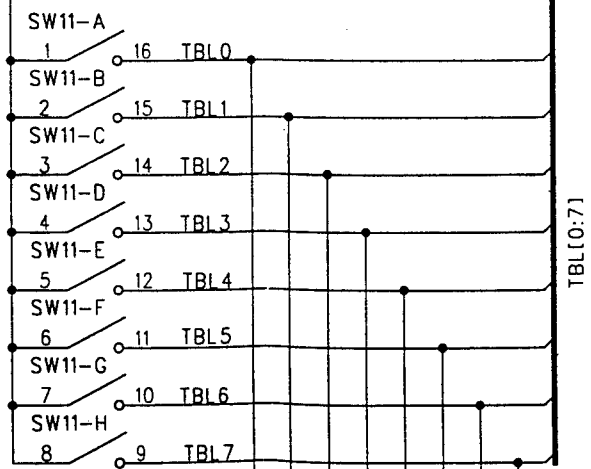
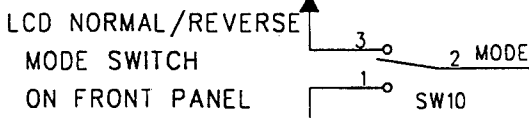
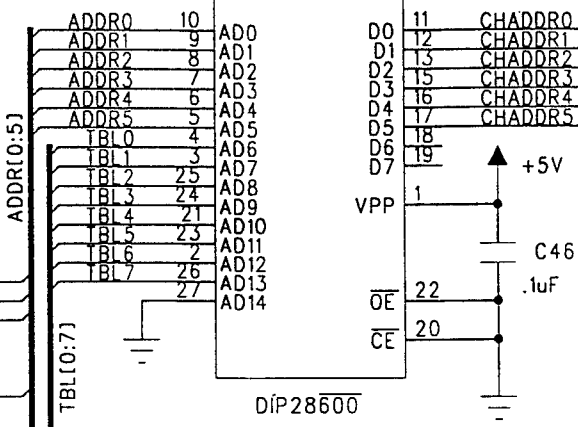
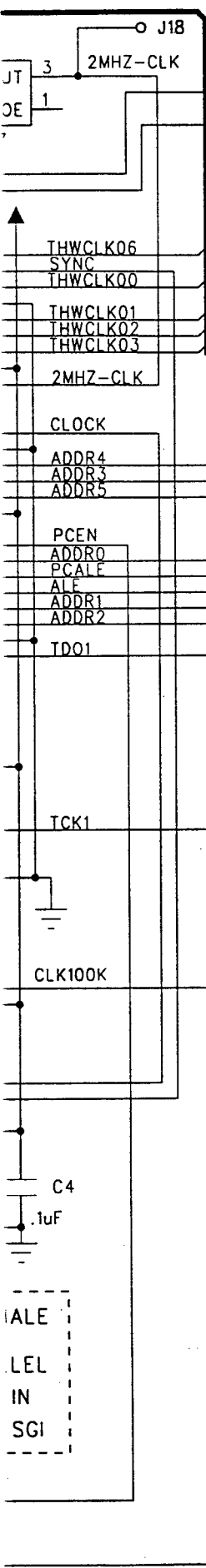

4.7K, 125mW

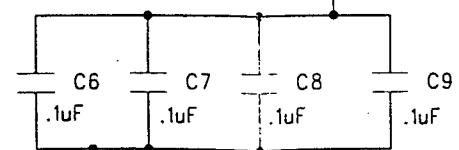
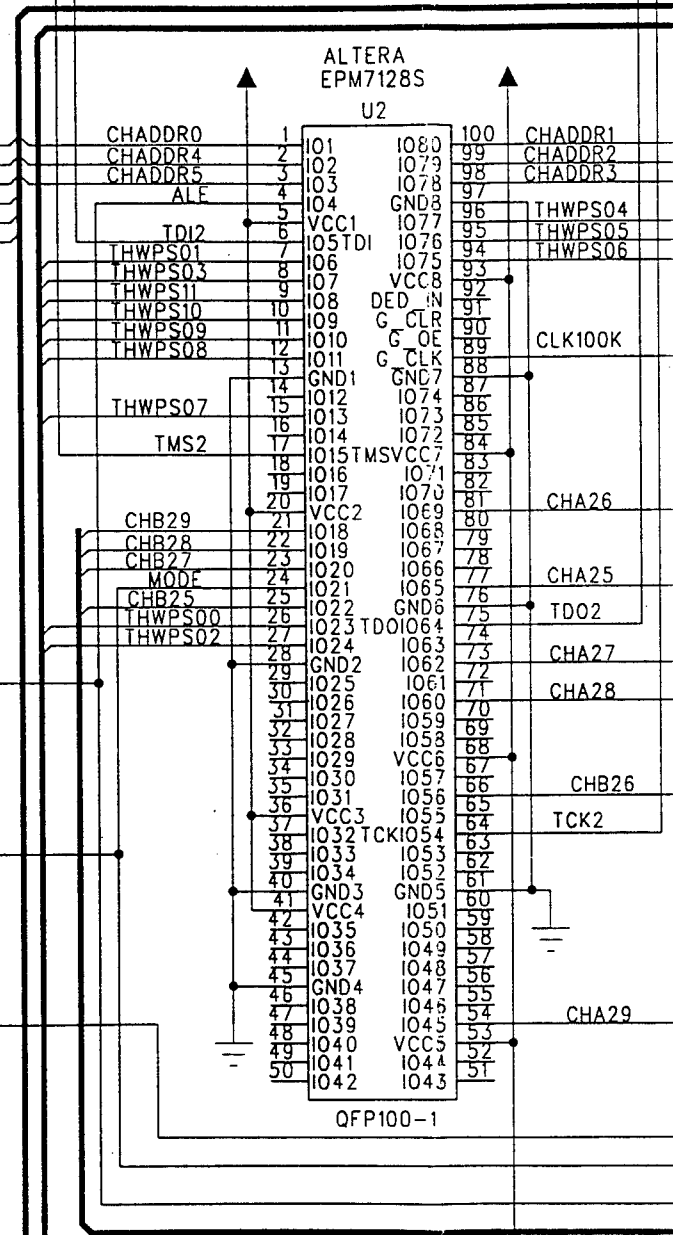

THIS PRINT IS
PC BOARD #ED1

- REVISION A NOTES:
- * CLK OSC. X1 SYMBOL WAS CORRECTED (PIN3 IS OUTPUT)
 - * CORRECTED SEQ. OF CHA AND CHB TO MATCH BACKPLANE (0-24 ARE NOW 25-49 AND VICE VERSA)



U2 HAS 5 PULSE WIDTH CKTS
AND SELECT LOGIC
(CH25 TO CH29)

CKET

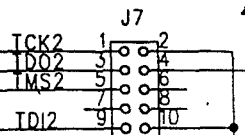

U2 PROG PORT

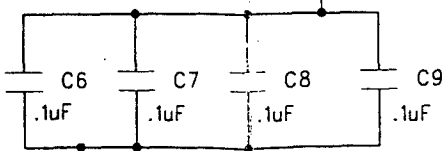
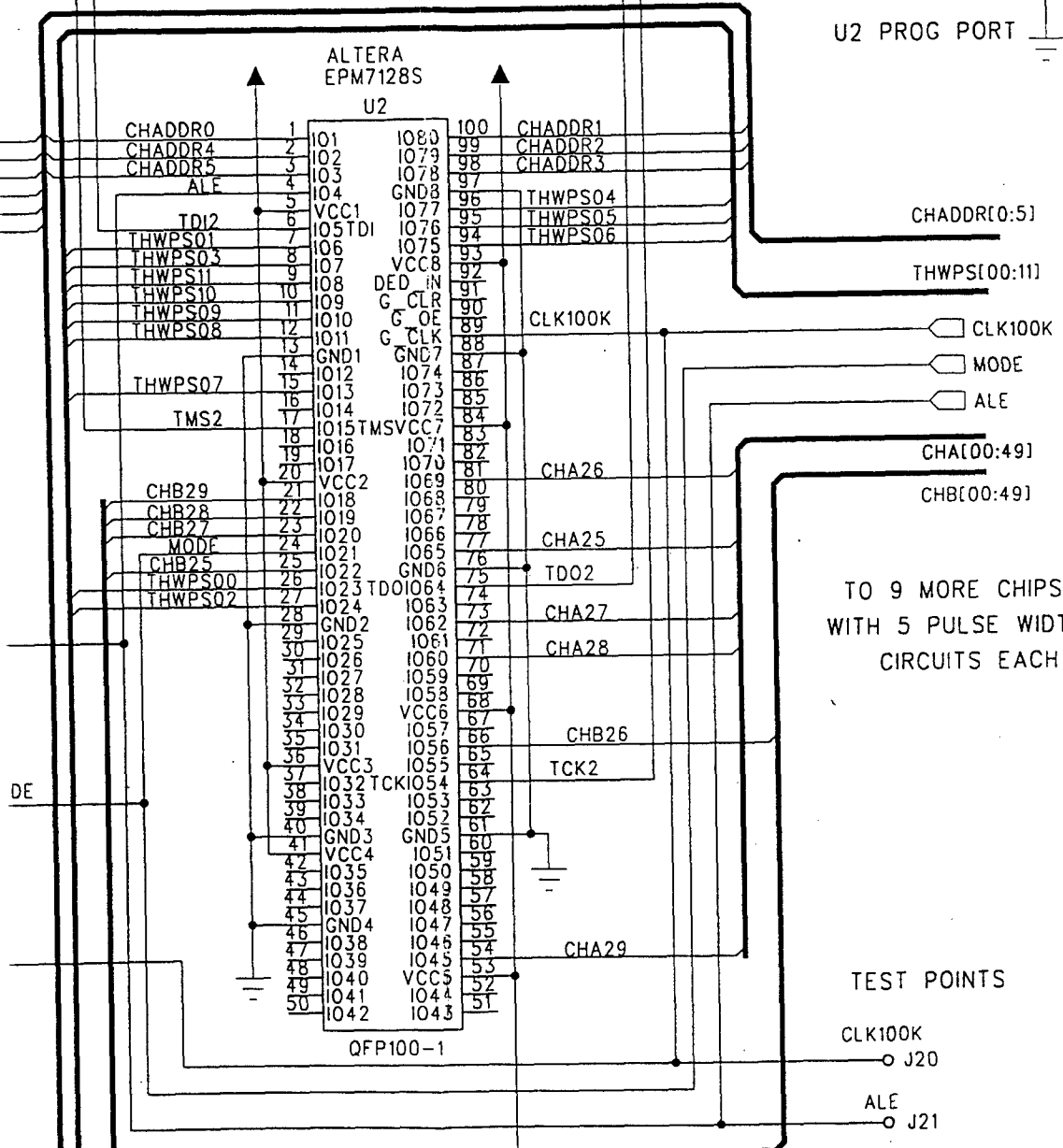

THIS PRINT IS AS BUILT ON THE FIRST PROTO
PC BOARD #EDL9742

REVISION A NOTES:

- * CLK OSC. X1 SYMBOL WAS CORRECTED (PIN3 IS OUTPUT)
- * CORRECTED SEQ. OF CHA AND CHB TO MATCH BACKPLANE (0-24 ARE NOW 25-49 AND VICE VERSA)

3

 ELECTRONIC DESIGN LAB REDDING, CT 06896 (203) 938-2142	CLIENT DIMENSIONAL MEDIA ASSOC	
	PROJECT MOE DRIVER	REV A
	LOGIC BOARD INPUT LOGIC AND PULSE STRETCHER CHANNELS 0 TO 4	
	DRAWING BY JEP	DATE 7-1-97
DESIGN BY JOG		
JOB 601	DRAWING#	#: 1 OF 5

EACH ALTERA FPGA CHIP CONTAINS 5 PUL (CH35 TO CH39)
(CH35 TO CH39)

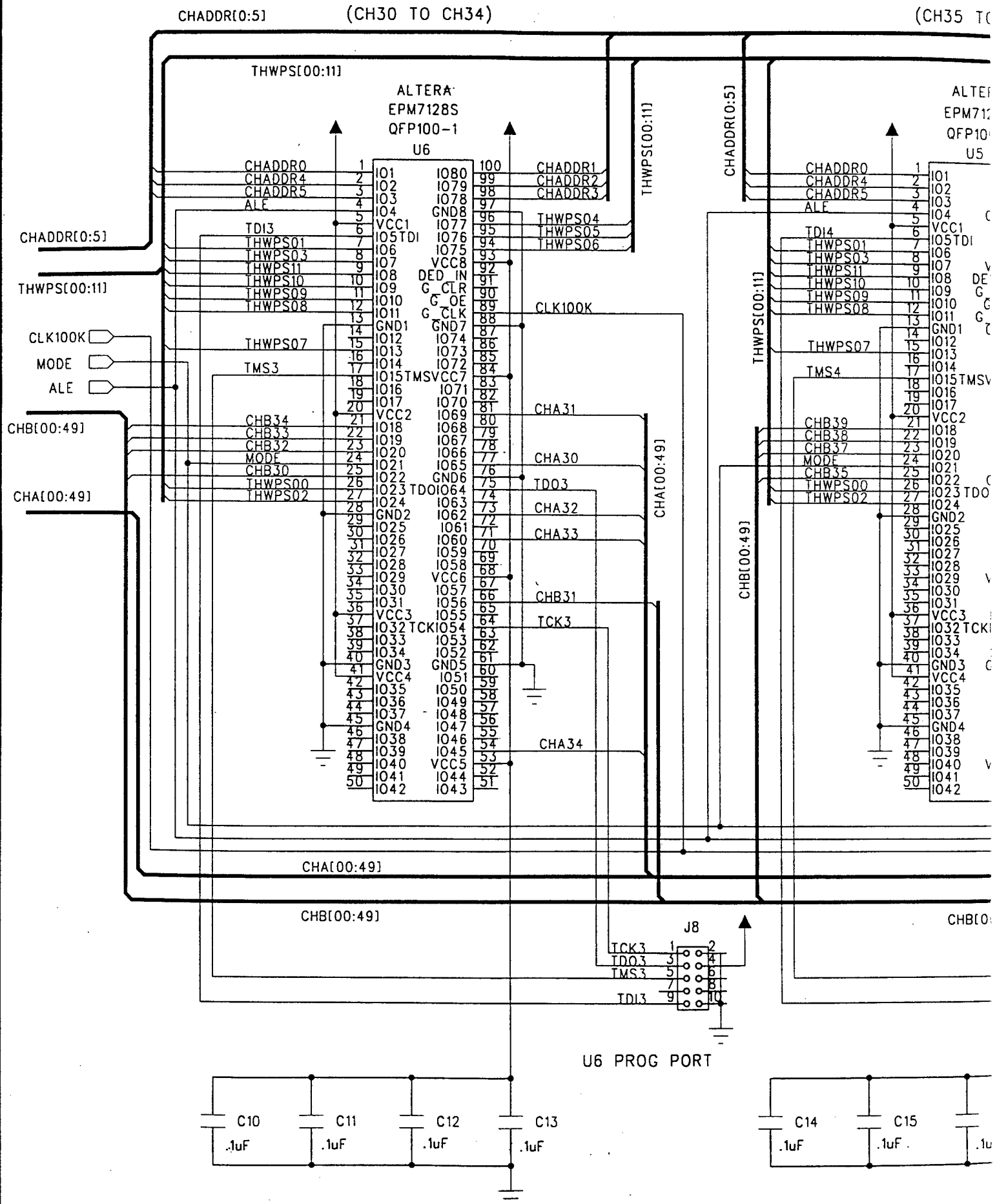

TERA FPGA CHIP CONTAINS 5 PULSE WIDTH CKTS AND SELECT LOGIC
(CH35 TO CH39)

CHADDR[0:5] (CH40 TO CH44)

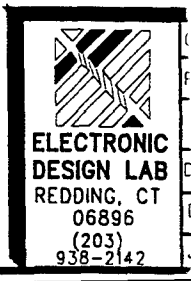
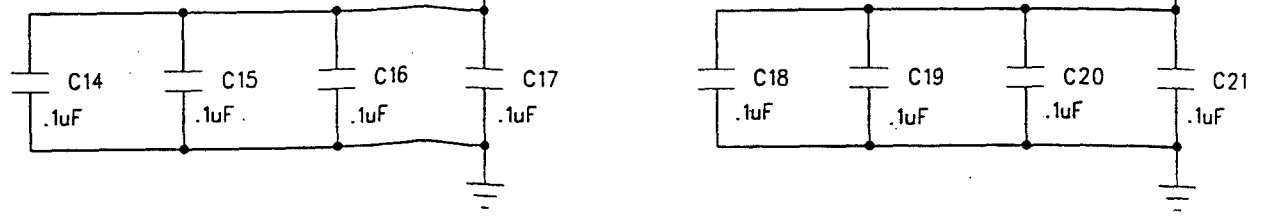
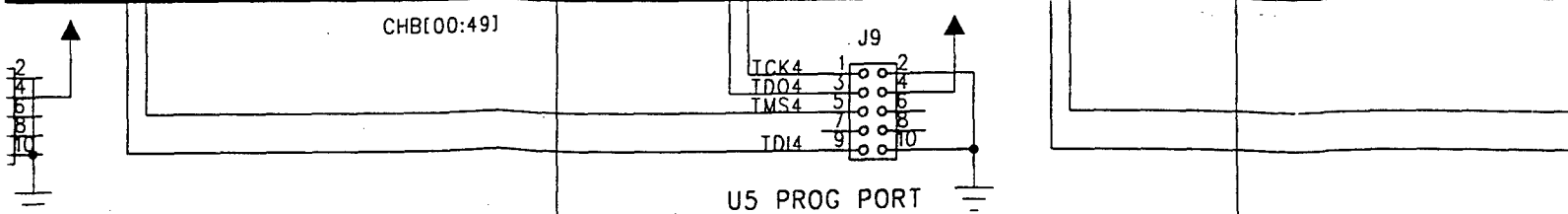
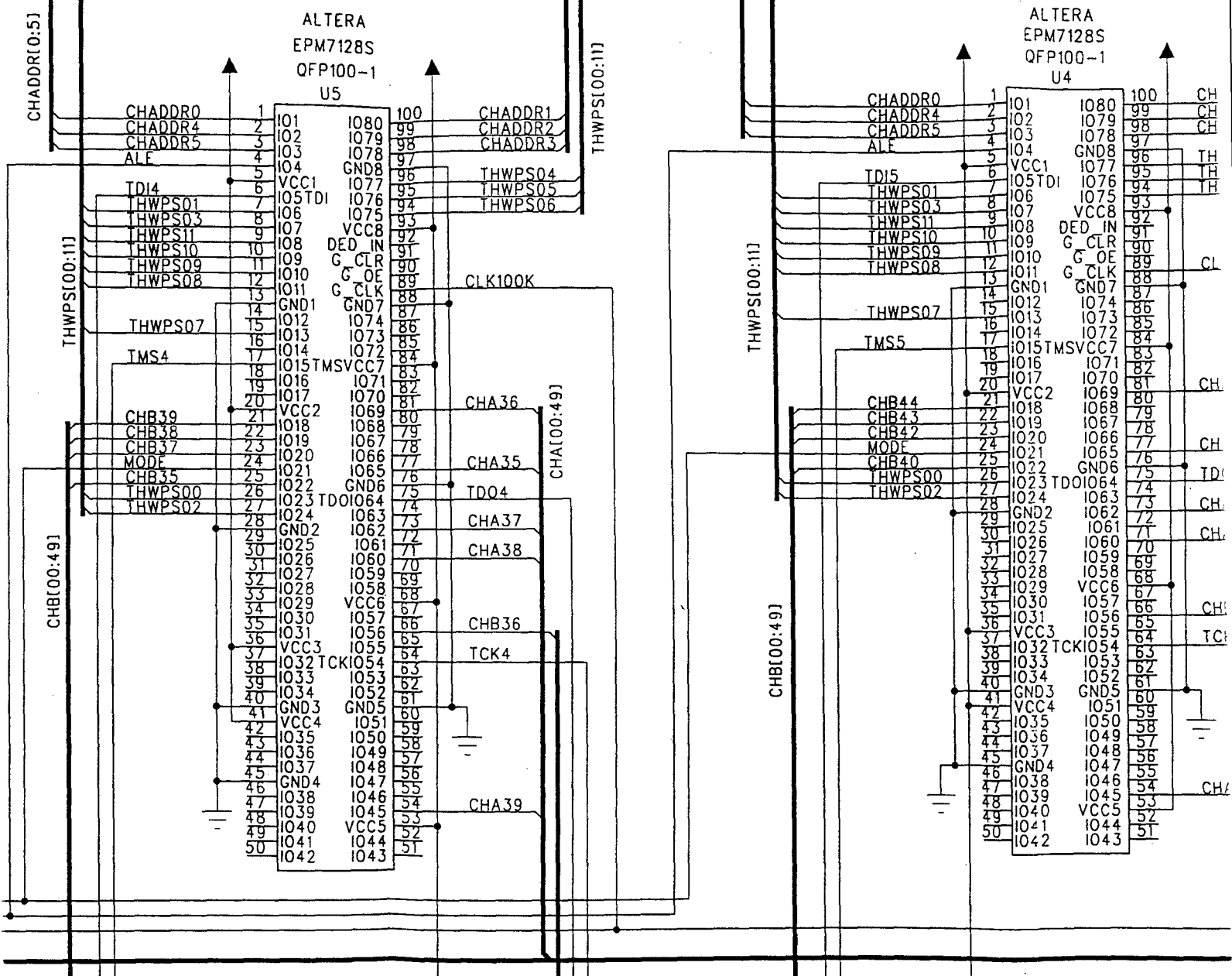

D SELECT LOGIC

CHADDR[0:5]

(CH40 TO CH44)

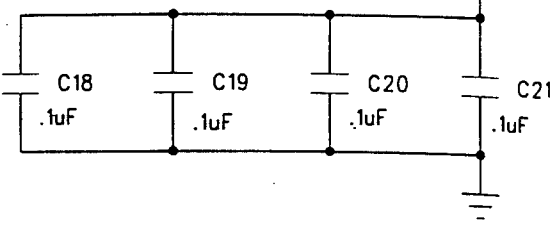
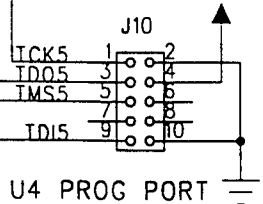
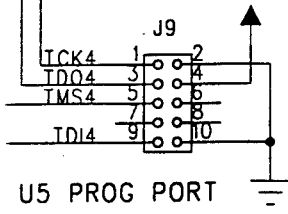
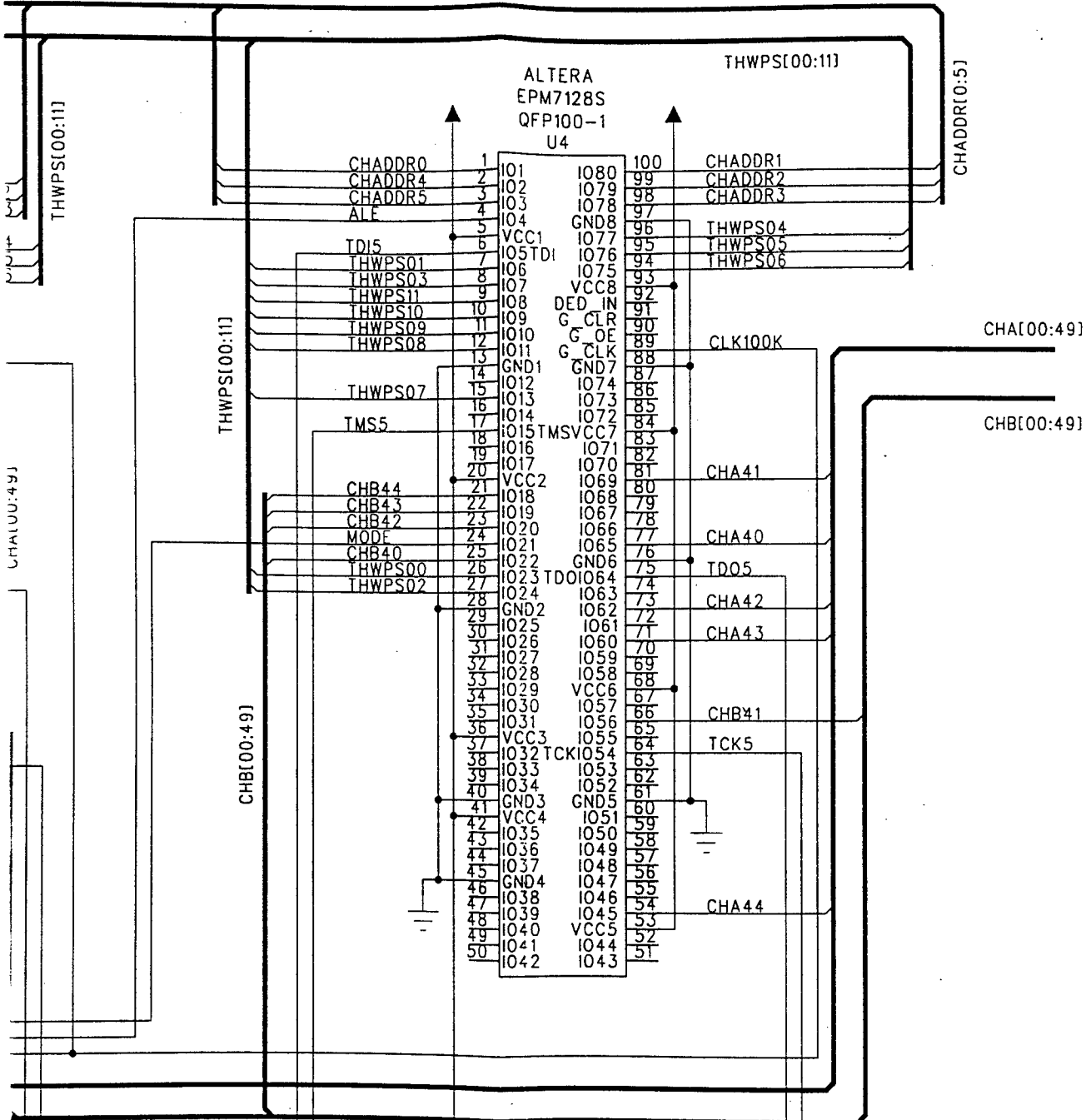

 ELECTRONIC DESIGN LAB REDDING, CT 06896 (203) 938-2142	CLIENT DIMENSIONAL MEDIA ASSOC	
	PROJECT MOE DRIVER	REV A
	LOGIC BOARD PULSE STRETCHER CHANNELS 5 TO 19	
	DRAWING BY JEP	DATE 7-1-97
	DESIGN BY JOG	
JOB 601	DRAWING#	#: 2 OF 5

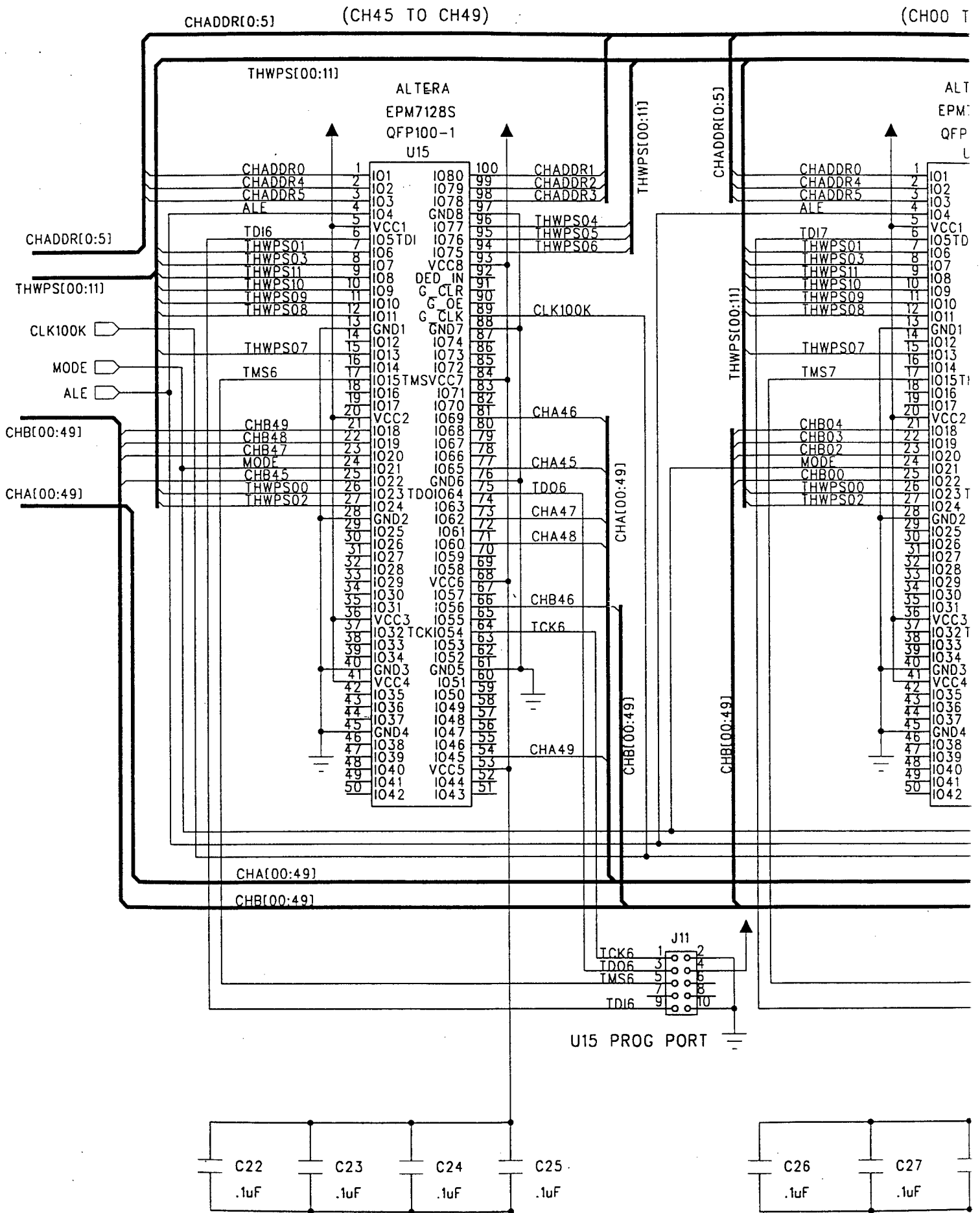

EACH ALTERA FPGA CHIP CONTAINS 5 PULSE WIDTH CKTS AND SELECT LOGIC

(CH00 TO CH04)

CHADDR[0:5]

(CH05 TO CH09)

U13

ALTERA
EPM7128S
QFP100-1
U13

ALTERA
EPM7128S
QFP100-1
U12

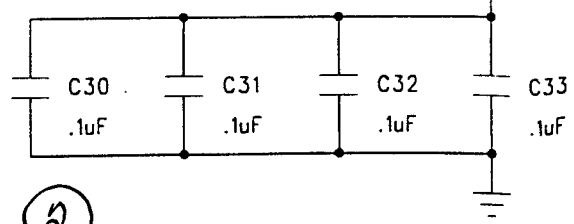
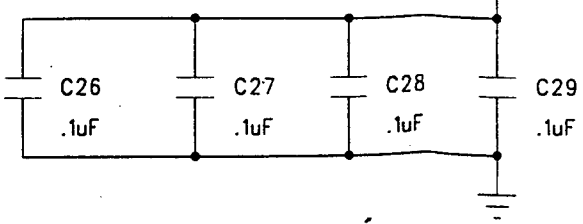
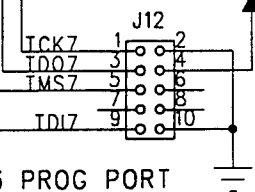
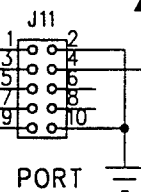
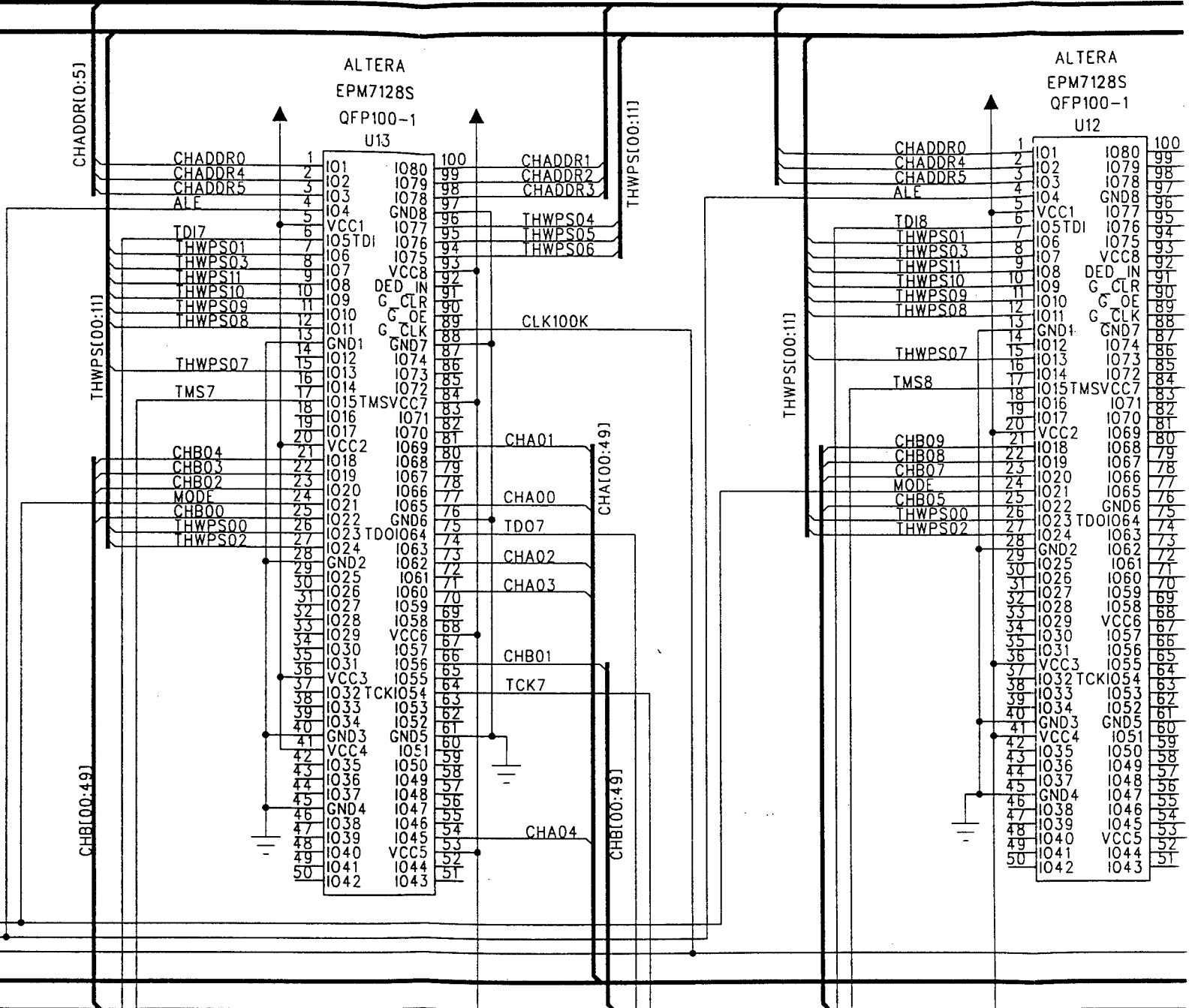

2



NO SELECT LOGIC

CHADDR[0:5]

(CH05 TO CH09)

THWPS[00:11]

ALTERA
EPM7128S
QFP100-1
U12

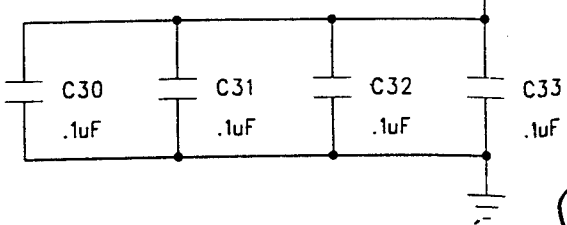
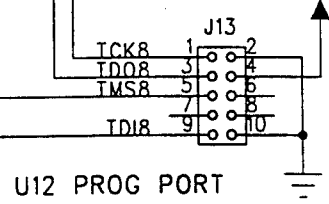
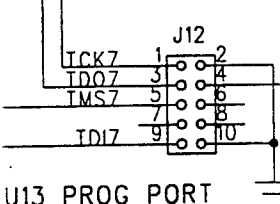
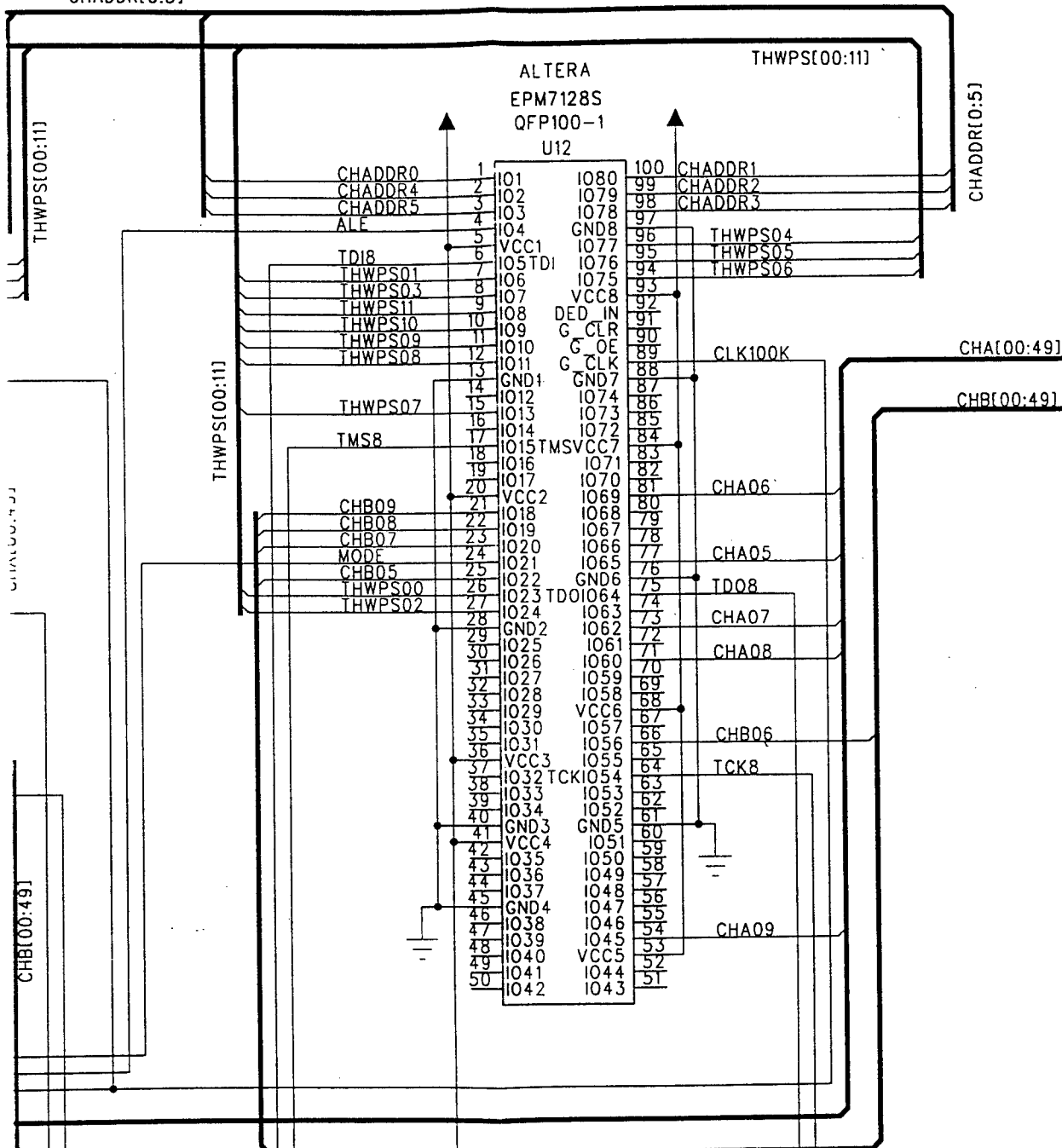

3

 ELECTRONIC DESIGN LAB REDDING, CT 06896 (203) 938-2142	CLIENT DIMENSIONAL MEDIA ASSOC	
	PROJECT MOE DRIVER	REV A
	LOGIC BOARD PULSE STRETCHER CHANNELS 20 TO 34	
	DRAWING BY JOG	DATE 7-1-97
DESIGN BY JOG	JOB 601	DRAWING# # 3 OF 5

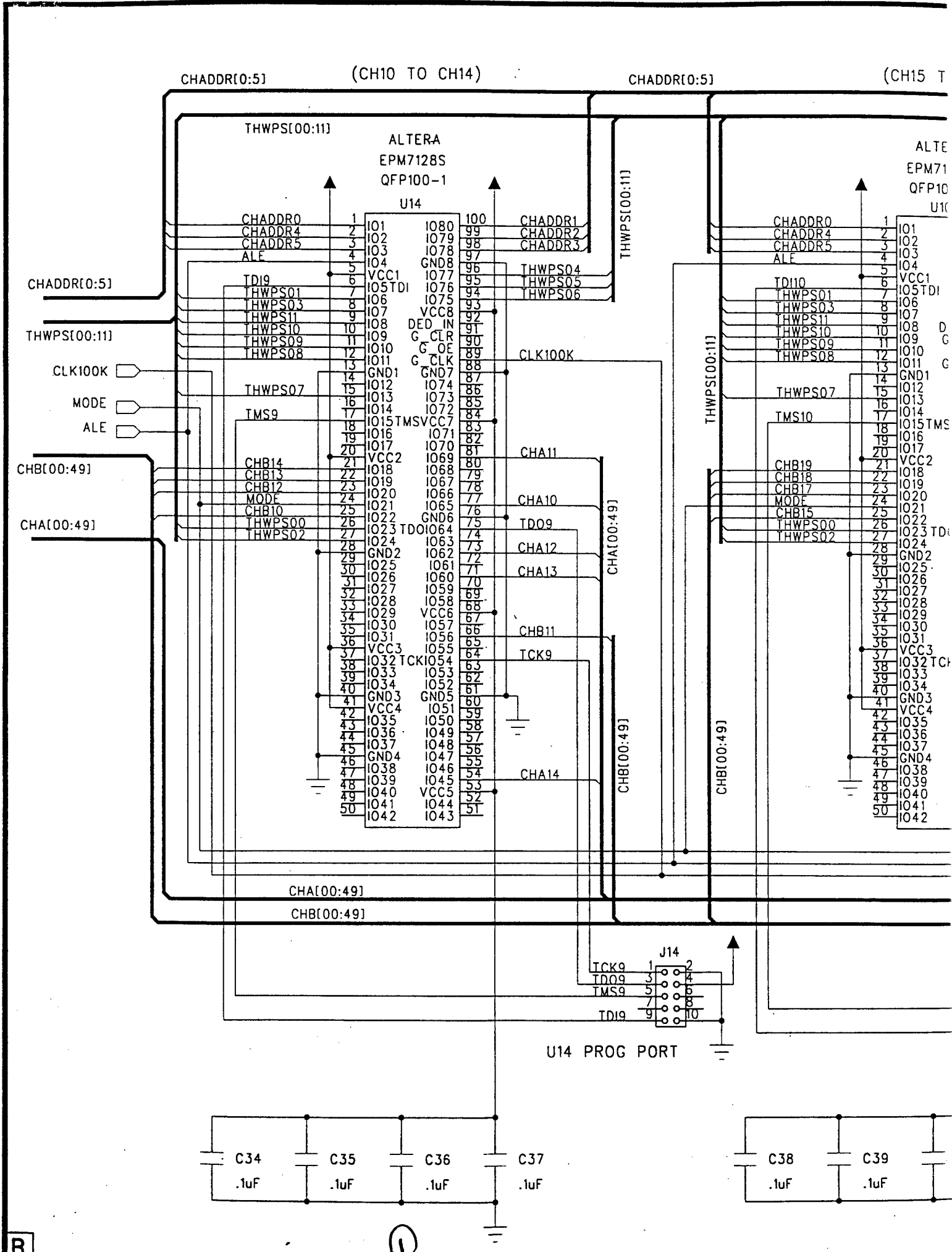

B

1

[0:5]

(CH15 TO CH19)

CHADDR[0:5]

(CH20 TO CH24)

ALTERA
EPM7128S
QFP100-1
U10

ALTERA
EPM7128S
QFP100-1
U7

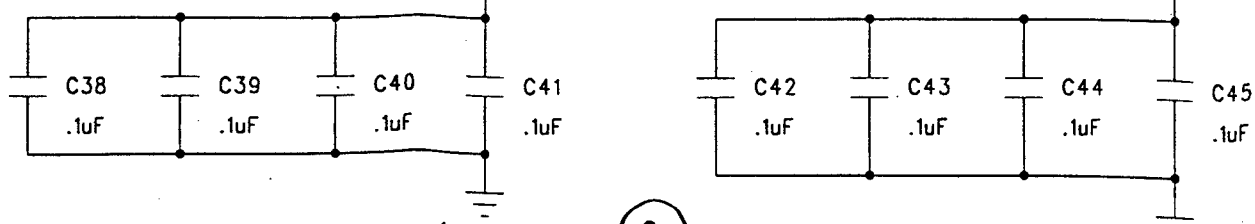
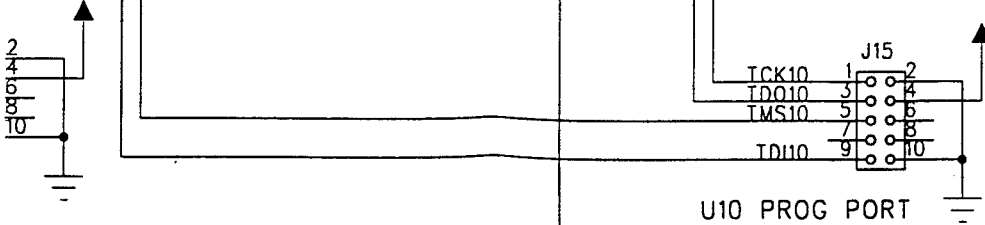
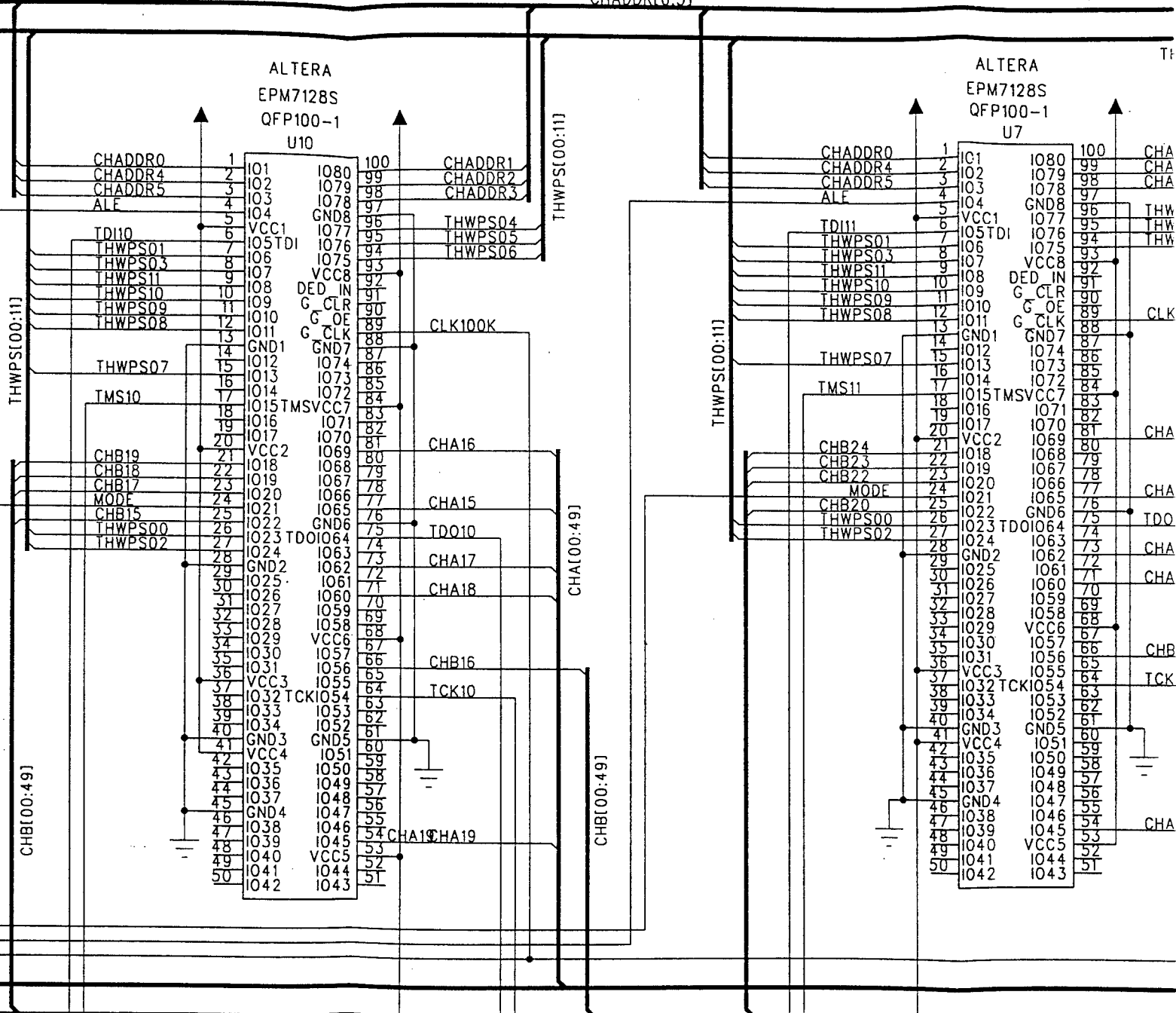

2

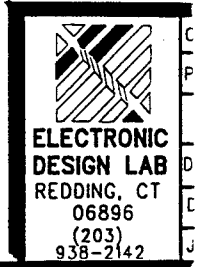

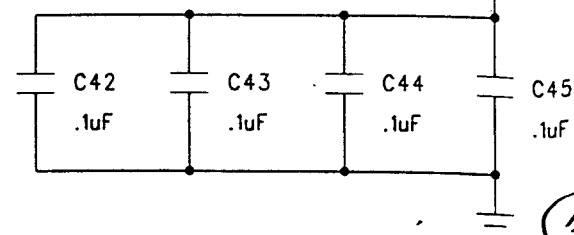
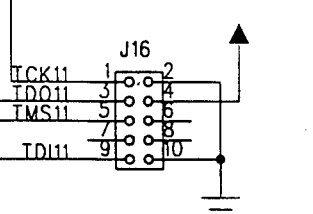
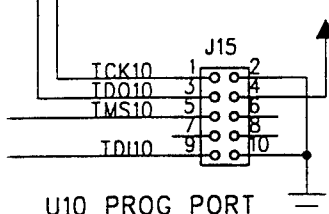
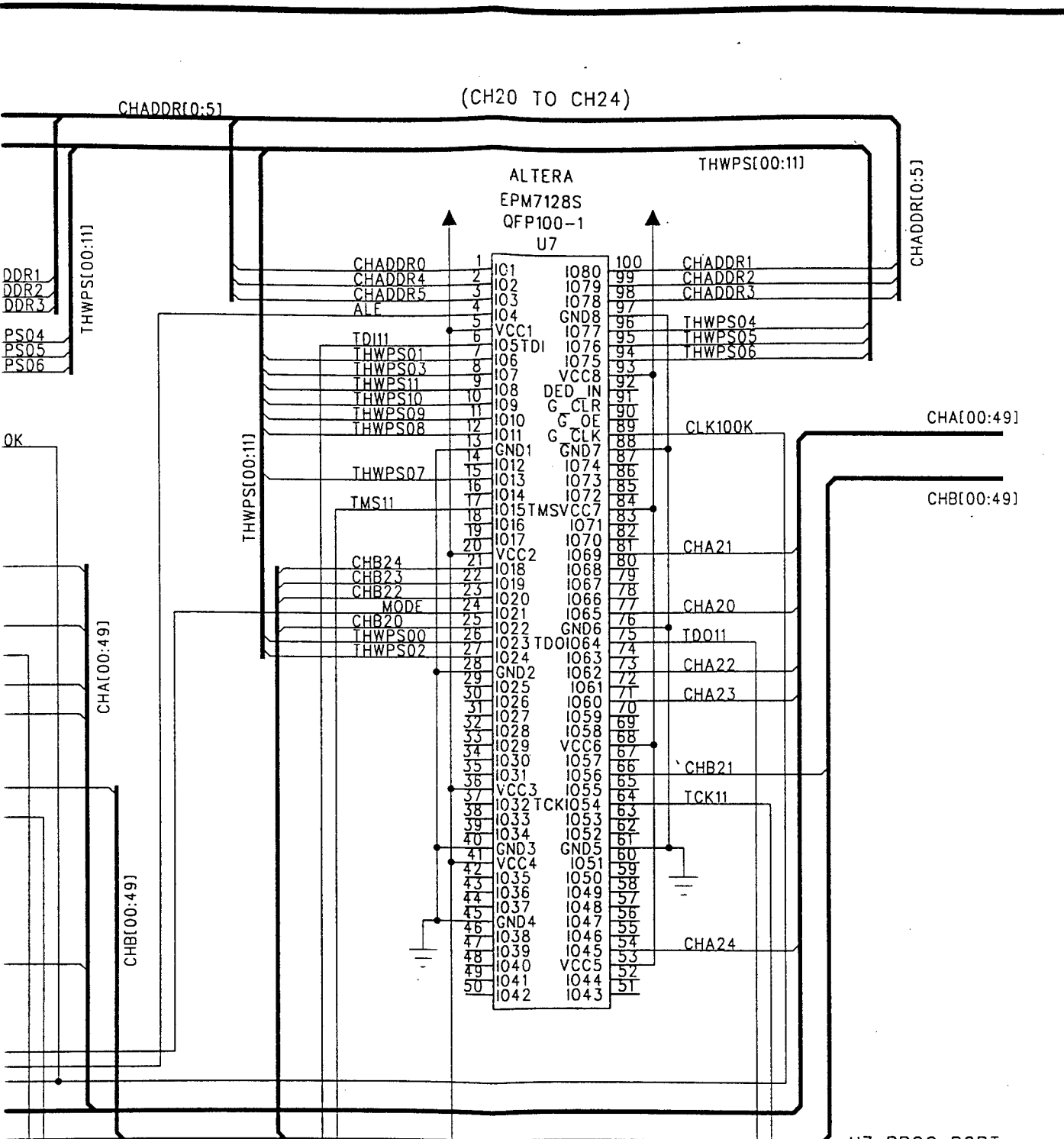

<p>ELECTRONIC DESIGN LAB REDDING, CT 06896 (203) 938-2142</p>	CLIENT DIMENSIONAL MEDIA ASSOC	
	PROJECT MOE DRIVER	REV A
	LOGIC BOARD PULSE STRETCHER CHANNELS 35 TO 49	
	DRAWING BY JOG	DATE 7-1-97
DESIGN BY JOG	JOB 601	DRAWING# #: 4 OF 5

3

UPPER BACKPLANE CONNECTOR

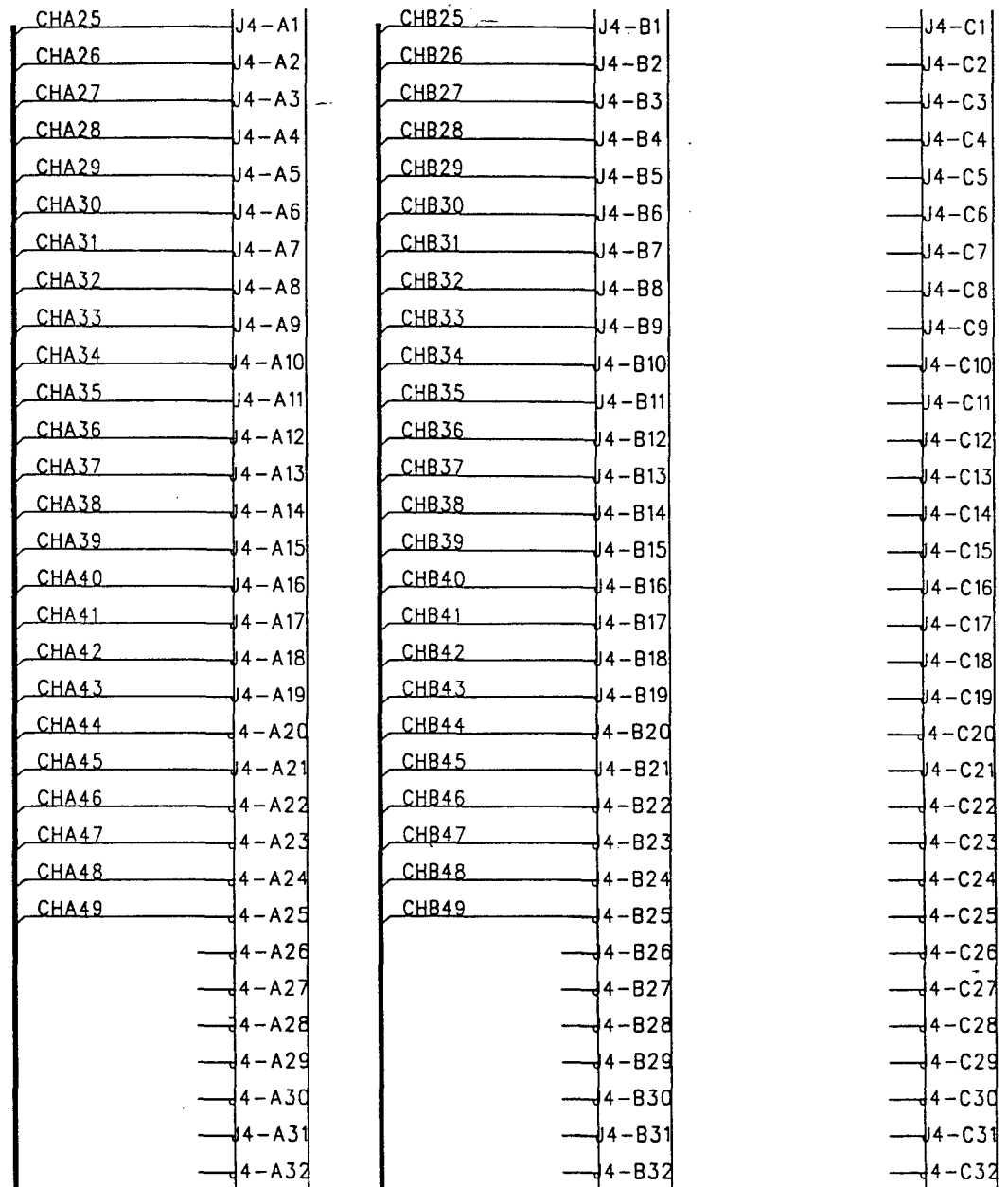

CHA[00:49]

CHB[00:49]

96 PIN MALE DIN CONNECTORS TO INTER

PLANE CONNECTOR

LOWER BACKPLANE

- J4-B1
 - J4-B2
 - J4-B3
 - J4-B4
 - J4-B5
 - J4-B6
 - J4-B7
 - J4-B8
 - J4-B9
 - J4-B10
 - J4-B11
 - J4-B12
 - J4-B13
 - J4-B14
 - J4-B15
 - J4-B16
 - J4-B17
 - J4-B18
 - J4-B19
 - J4-B20
 - J4-B21
 - J4-B22
 - J4-B23
 - J4-B24
 - J4-B25
 - J4-B26
 - J4-B27
 - J4-B28
 - J4-B29
 - J4-B30
 - J4-B31
 - J4-B32
- J4-C1
 - J4-C2
 - J4-C3
 - J4-C4
 - J4-C5
 - J4-C6
 - J4-C7
 - J4-C8
 - J4-C9
 - J4-C10
 - J4-C11
 - J4-C12
 - J4-C13
 - J4-C14
 - J4-C15
 - J4-C16
 - J4-C17
 - J4-C18
 - J4-C19
 - J4-C20
 - J4-C21
 - J4-C22
 - J4-C23
 - J4-C24
 - J4-C25
 - J4-C26
 - J4-C27
 - J4-C28
 - J4-C29
 - J4-C30
 - J4-C31
 - J4-C32

- CHA00
 - CHA01
 - CHA02
 - CHA03
 - CHA04
 - CHA05
 - CHA06
 - CHA07
 - CHA08
 - CHA09
 - CHA10
 - CHA11
 - CHA12
 - CHA13
 - CHA14
 - CHA15
 - CHA16
 - CHA17
 - CHA18
 - CHA19
 - CHA20
 - CHA21
 - CHA22
 - CHA23
 - CHA24
- J5-A1
 - J5-A2
 - J5-A3
 - J5-A4
 - J5-A5
 - J5-A6
 - J5-A7
 - J5-A8
 - J5-A9
 - J5-A10
 - J5-A11
 - J5-A12
 - J5-A13
 - J5-A14
 - J5-A15
 - J5-A16
 - J5-A17
 - J5-A18
 - J5-A19
 - J5-A20
 - J5-A21
 - J5-A22
 - J5-A23
 - J5-A24
 - J5-A25
 - J5-A26
 - J5-A27
 - J5-A28
 - J5-A29
 - J5-A30
 - J5-A31
 - J5-A32

- CHB00
- CHB01
- CHB02
- CHB03
- CHB04
- CHB05
- CHB06
- CHB07
- CHB08
- CHB09
- CHB10
- CHB11
- CHB12
- CHB13
- CHB14
- CHB15
- CHB16
- CHB17
- CHB18
- CHB19
- CHB20
- CHB21
- CHB22
- CHB23
- CHB24

MAIN POWER INPUT
+5V TIES TO LAYER 3 PLANE
AT C49

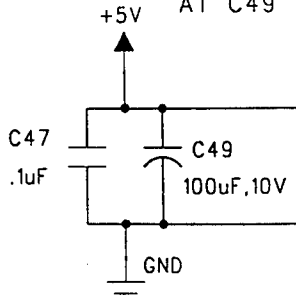

GND TIES TO LAYER 2 PLANE
AT C49

CHA[00:49]
CHB[00:49]

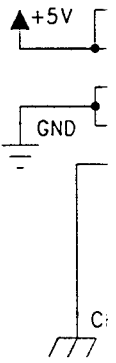
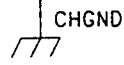

CHGND TIES ONLY TO FRONT

96 PIN MALE DIN CONNECTORS TO INTERFACE WITH VME SIZE 6U BACKPLANE

LOWER BACKPLANE CONNECTOR

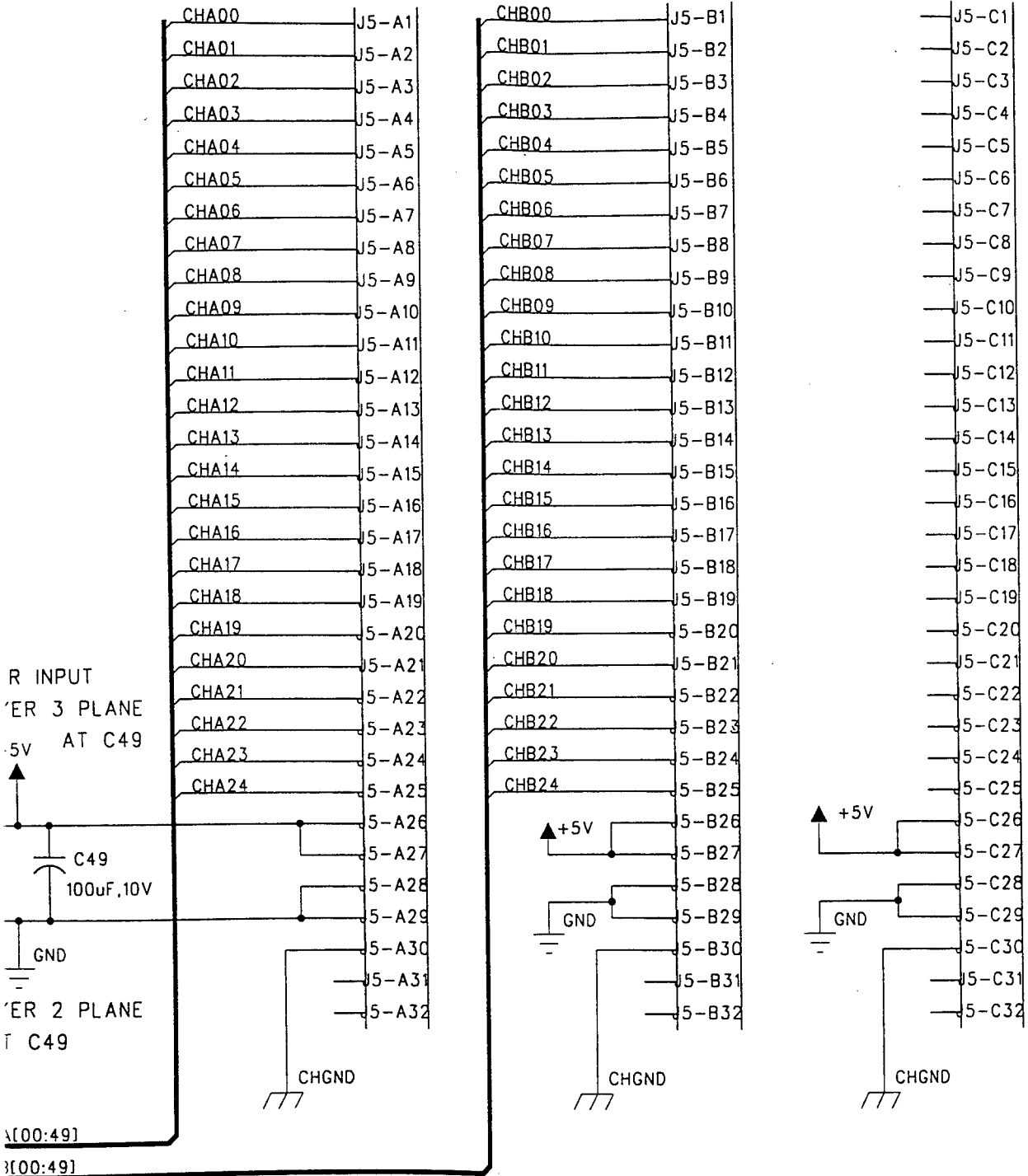

CHGND TIES ONLY TO FRONT PANEL BRACKET

6U BACKPLANE

AS BUILT ON PCB #EDL9742

 ELECTRONIC DESIGN LAB REDDING, CT 06896 (203) 938-2142	CLIENT DIMENSIONAL MEDIA ASSOC	
	PROJECT MOE DRIVER	REV A
	LOGIC BOARD CHANNELS 0 - 49 OUTPUT CONNECTORS	
	DRAWING BY JEP	DATE 7-1-97
	DESIGN BY JOG	
JOB 601	DRAWING#	# 5 OF 5

CHA[00:49]

CHB[00:49]

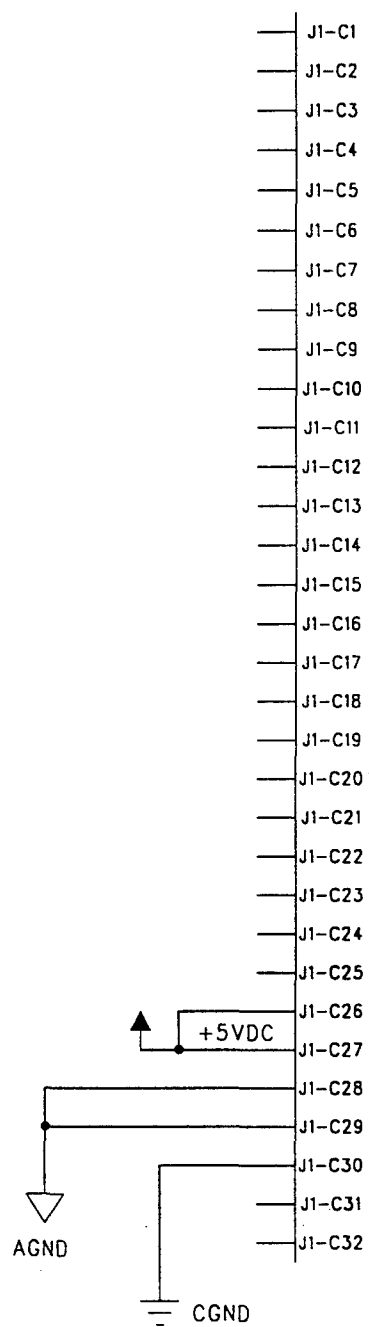
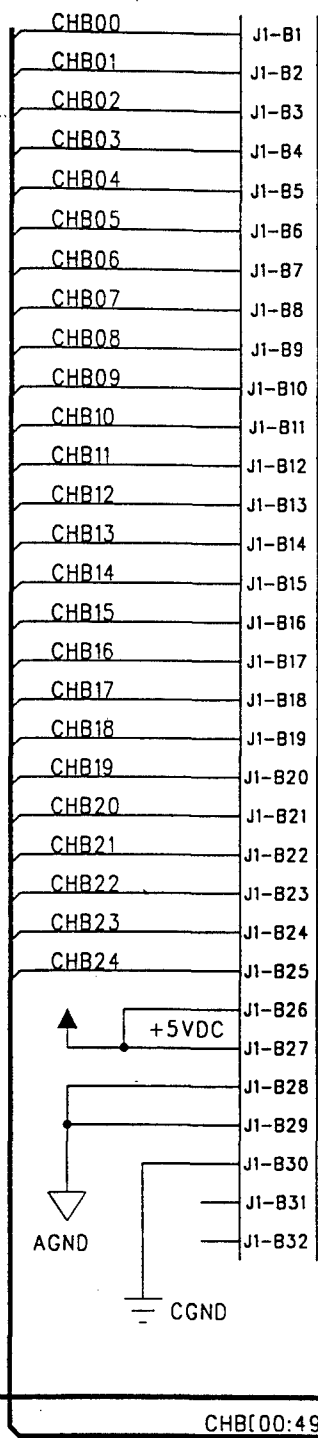
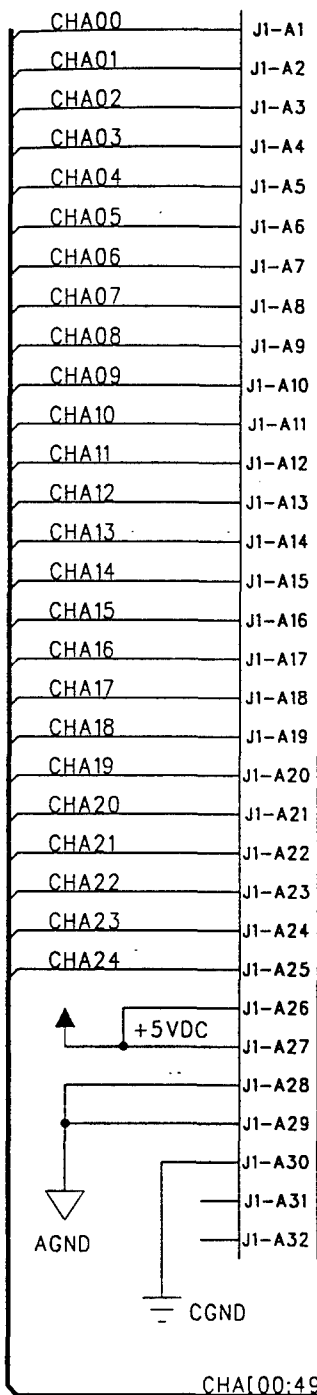

LOWER BACKPLANE CONNECTOR

CHA[00:49]

CHB[00:49]

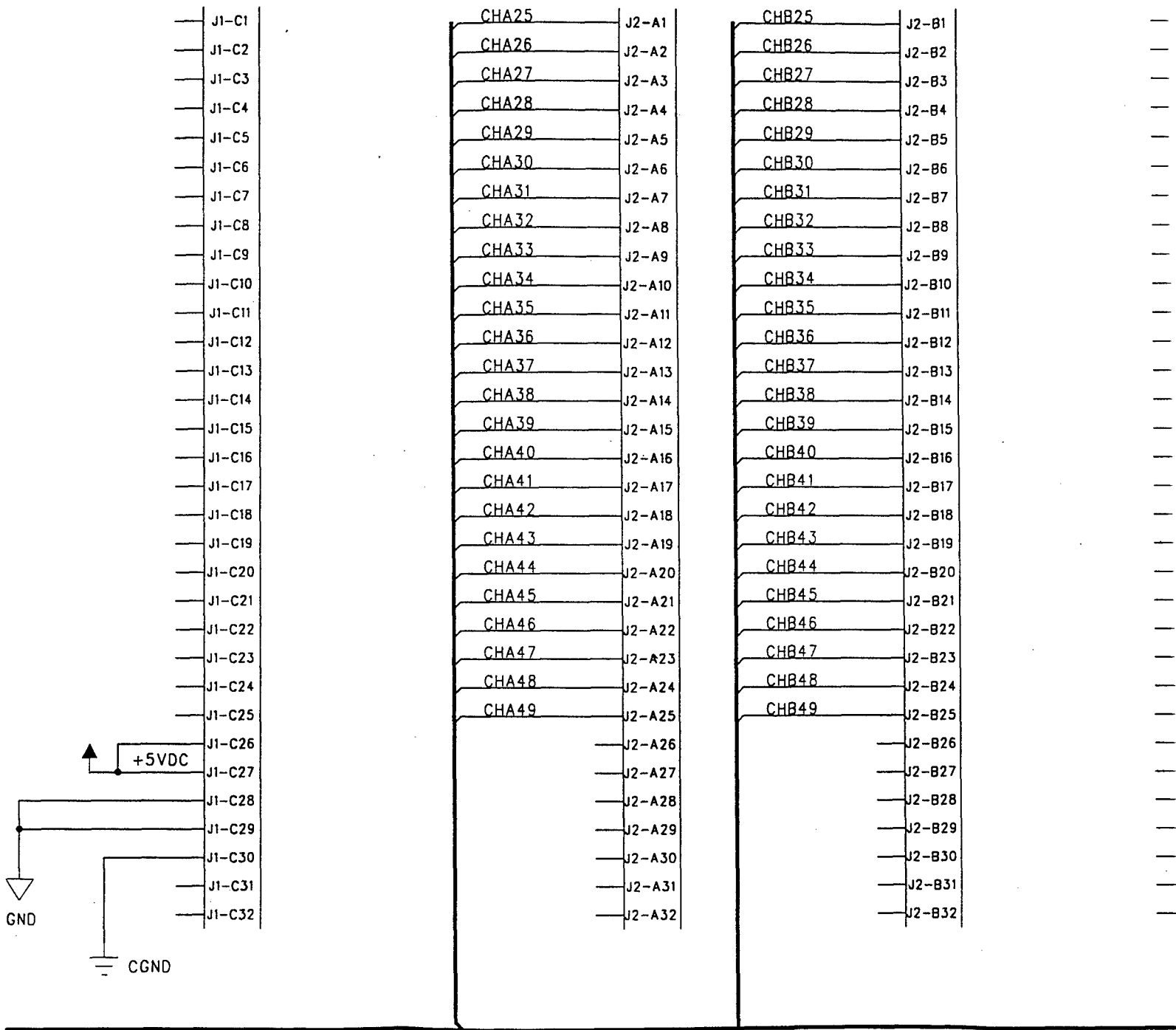

CONNECTOR

UPPER BACKPLANE CONNECTOR

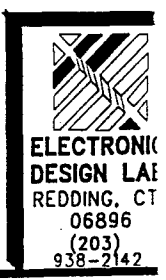

CHB(00:49)

J2-A1	CHB25	J2-B1	J2-C1
J2-A2	CHB26	J2-B2	J2-C2
J2-A3	CHB27	J2-B3	J2-C3
J2-A4	CHB28	J2-B4	J2-C4
J2-A5	CHB29	J2-B5	J2-C5
J2-A6	CHB30	J2-B6	J2-C6
J2-A7	CHB31	J2-B7	J2-C7
J2-A8	CHB32	J2-B8	J2-C8
J2-A9	CHB33	J2-B9	J2-C9
J2-A10	CHB34	J2-B10	J2-C10
J2-A11	CHB35	J2-B11	J2-C11
J2-A12	CHB36	J2-B12	J2-C12
J2-A13	CHB37	J2-B13	J2-C13
J2-A14	CHB38	J2-B14	J2-C14
J2-A15	CHB39	J2-B15	J2-C15
J2-A16	CHB40	J2-B16	J2-C16
J2-A17	CHB41	J2-B17	J2-C17
J2-A18	CHB42	J2-B18	J2-C18
J2-A19	CHB43	J2-B19	J2-C19
J2-A20	CHB44	J2-B20	J2-C20
J2-A21	CHB45	J2-B21	J2-C21
J2-A22	CHB46	J2-B22	J2-C22
J2-A23	CHB47	J2-B23	J2-C23
J2-A24	CHB48	J2-B24	J2-C24
J2-A25	CHB49	J2-B25	J2-C25
J2-A26		J2-B26	J2-C26
J2-A27		J2-B27	J2-C27
J2-A28		J2-B28	J2-C28
J2-A29		J2-B29	J2-C29
J2-A30		J2-B30	J2-C30
J2-A31		J2-B31	J2-C31
J2-A32		J2-B32	J2-C32

CHA(00:49)

CHB(00:49)

UPPER BACKPLANE CONNECTOR

3

 <p>ELECTRONIC DESIGN LAB REDDING, CT 06896 (203) 938-2142</p>	CLIENT DIMENSIONAL MEDIA ASSOC		
	PROJECT	MOE DRIVER	REV
	MOE ELECTRONICS BACKPLANE		
	DRAWING BY	MJA	DATE
DESIGN BY	MJA	10-20-97	
JOB	601	DRAWING#	#: 1 OF 2

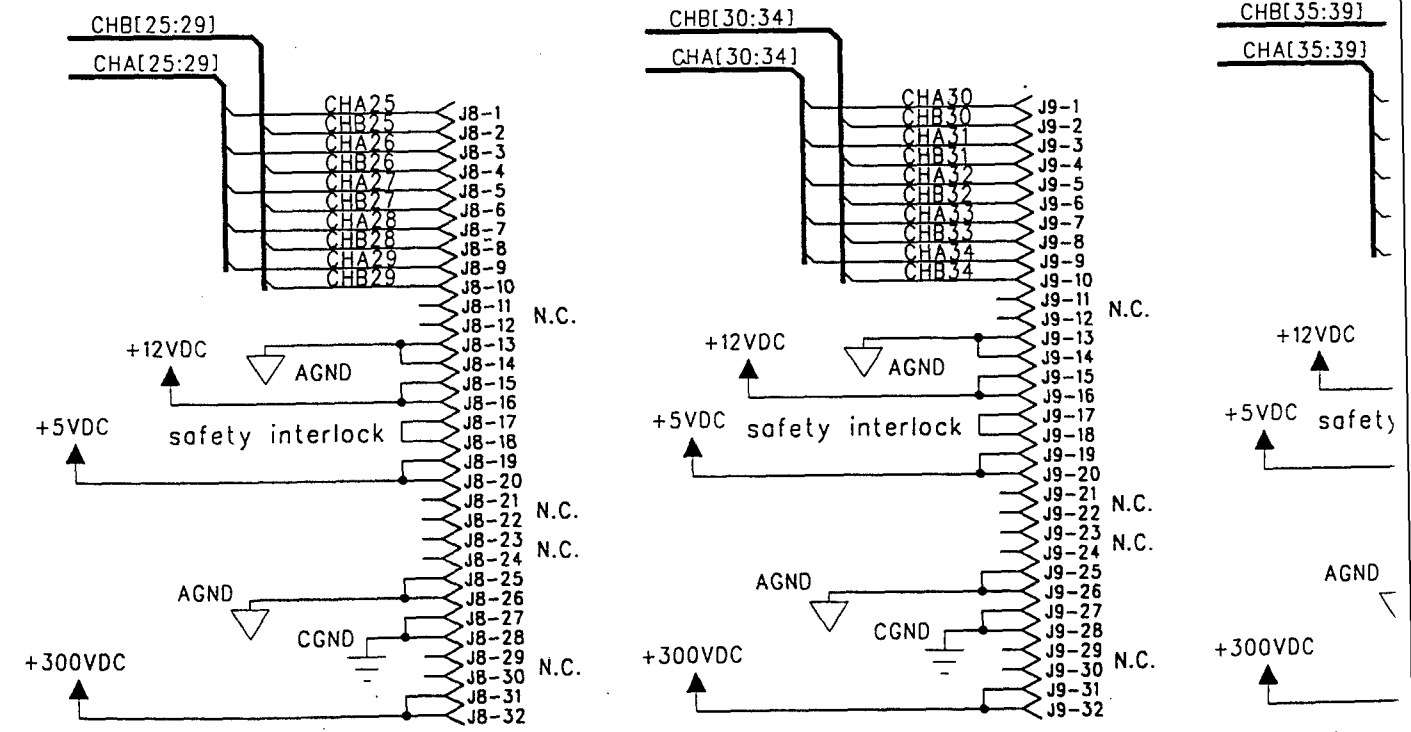
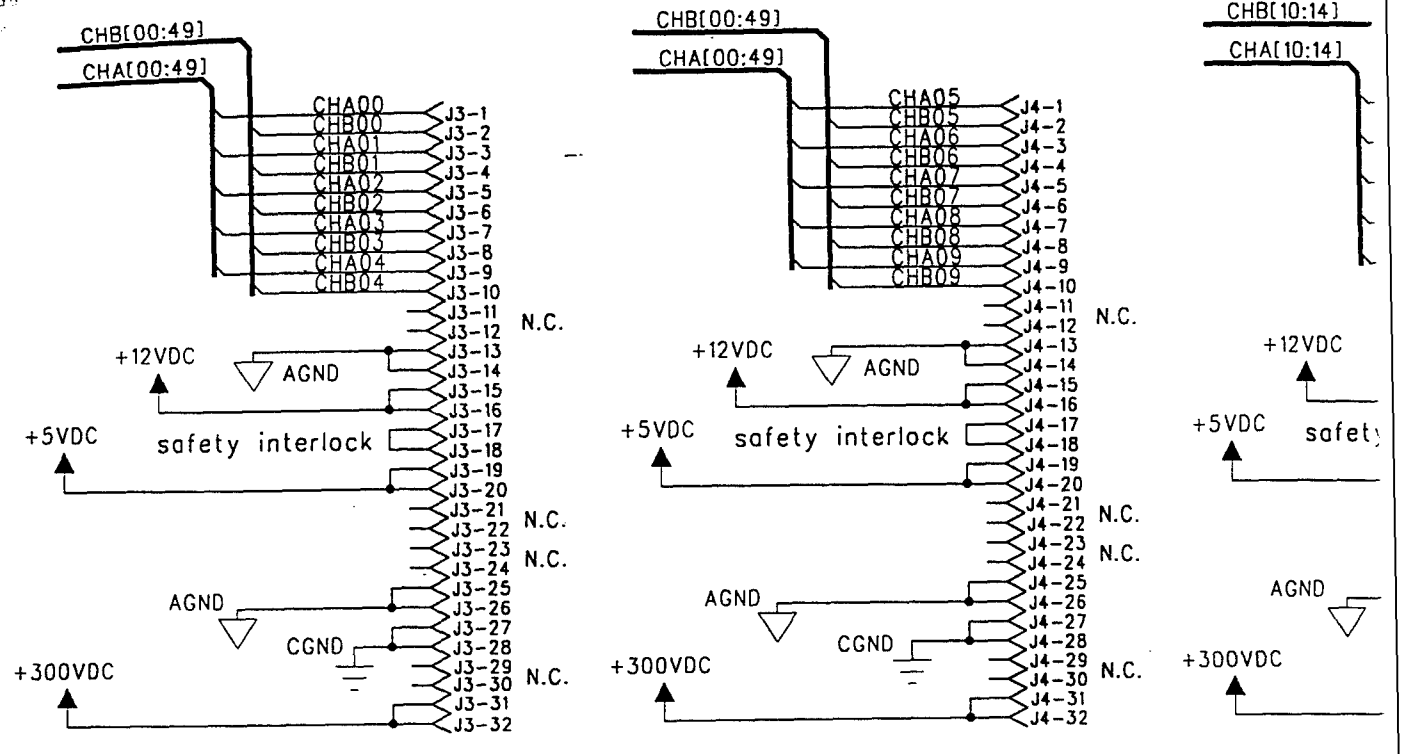

J13, 14, 16 connect to the linear power supply. J15 is a test point.

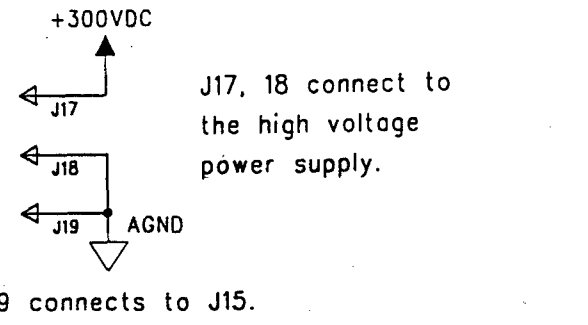
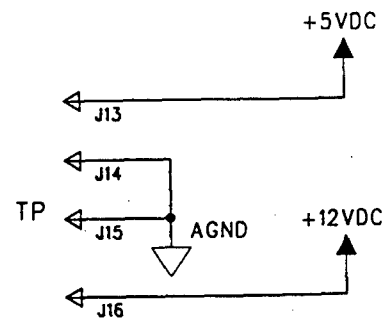

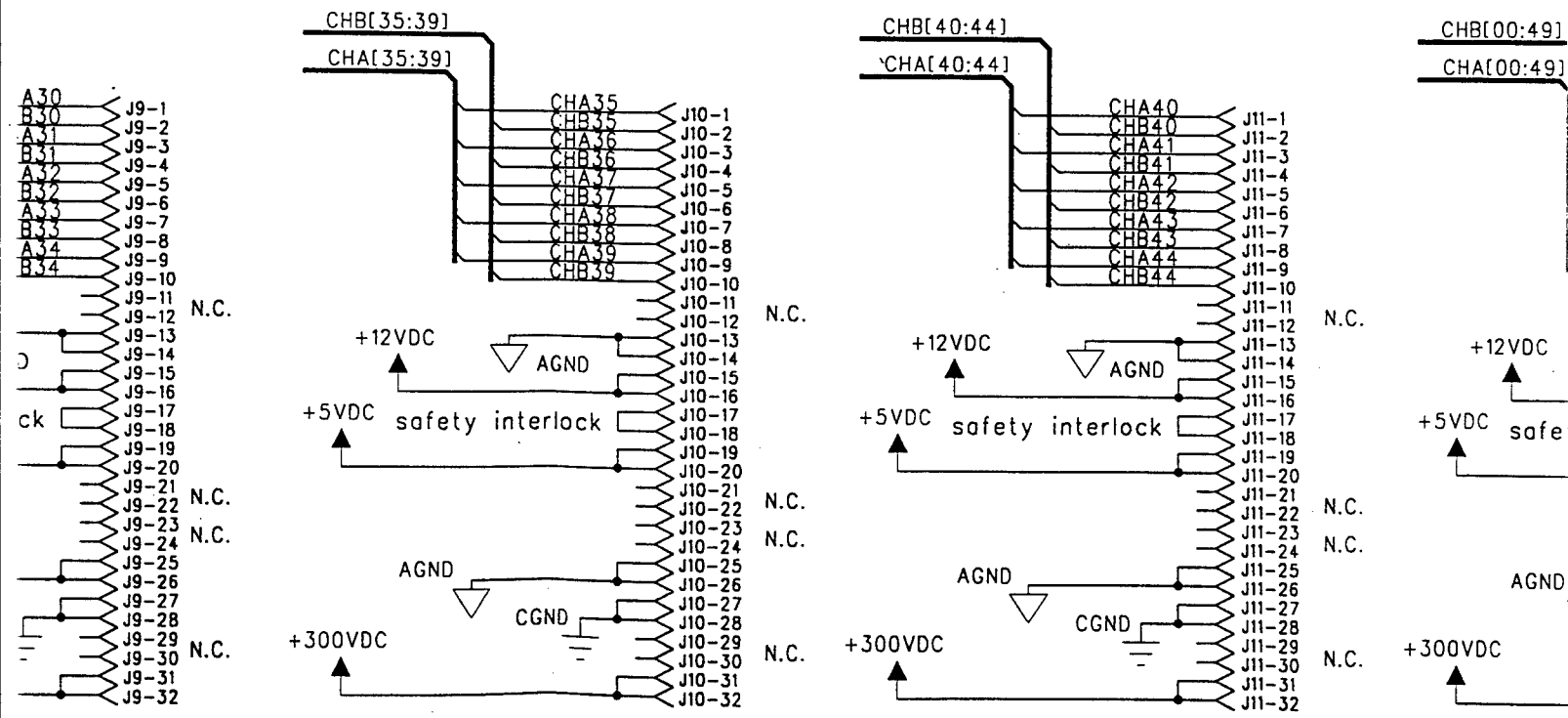
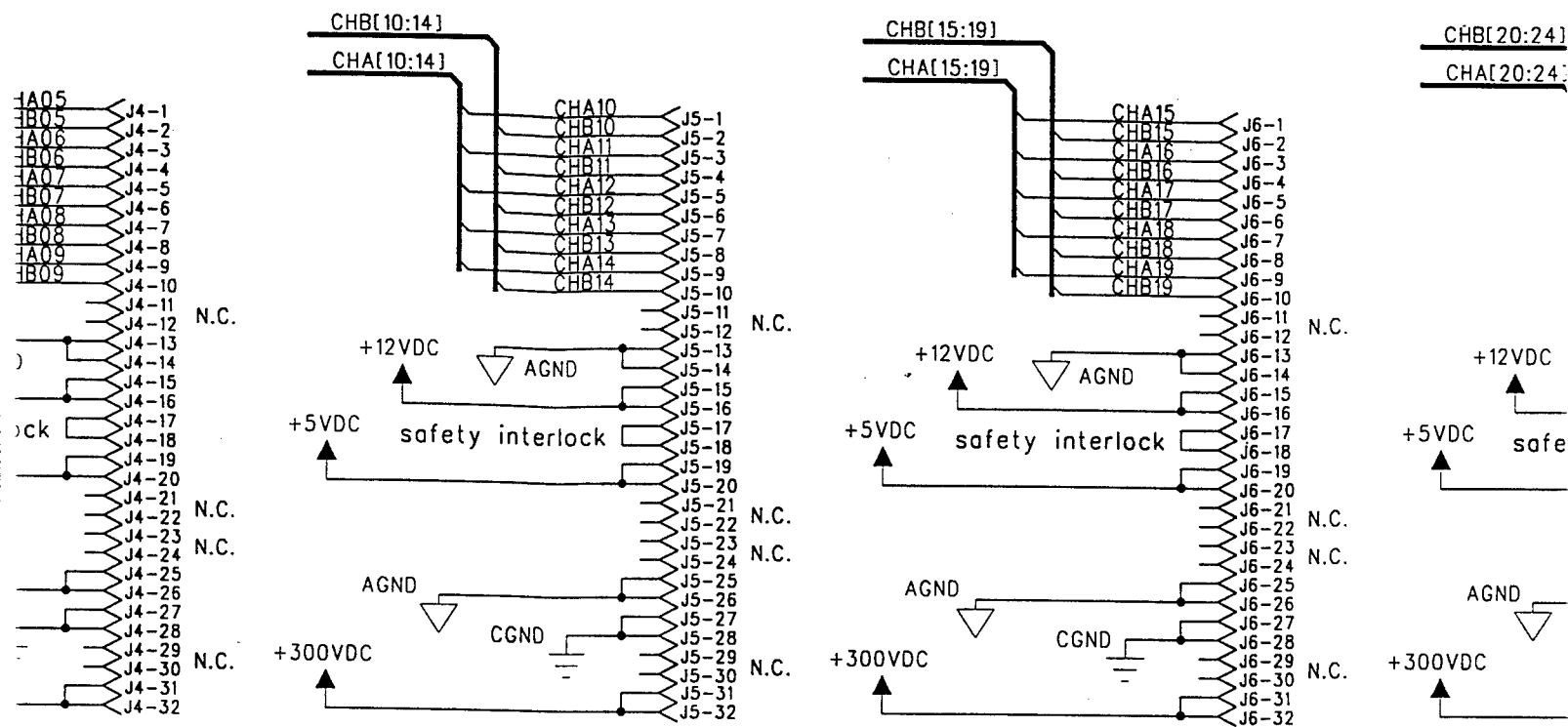

J17, 18 connect to the high voltage power supply.

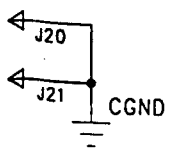

TP = Test Point
 CGND = Chassis Ground
 AGND = Analog Ground

AGND

connects to J15.

②

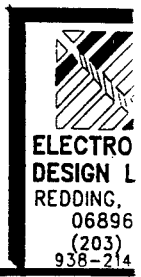

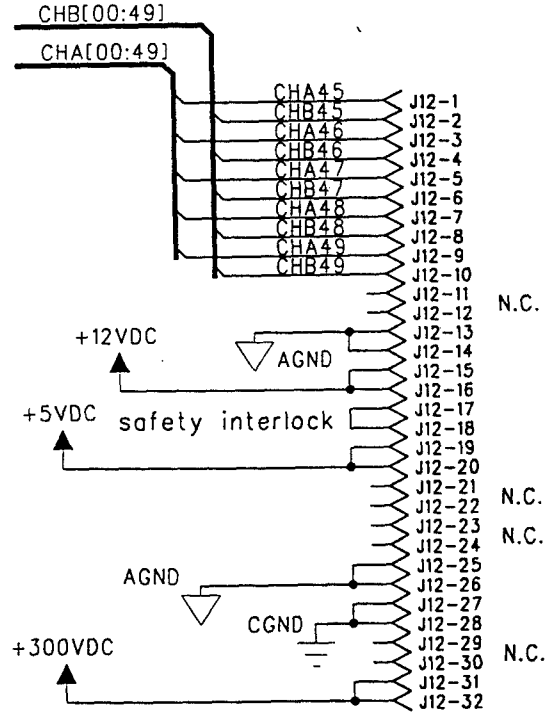
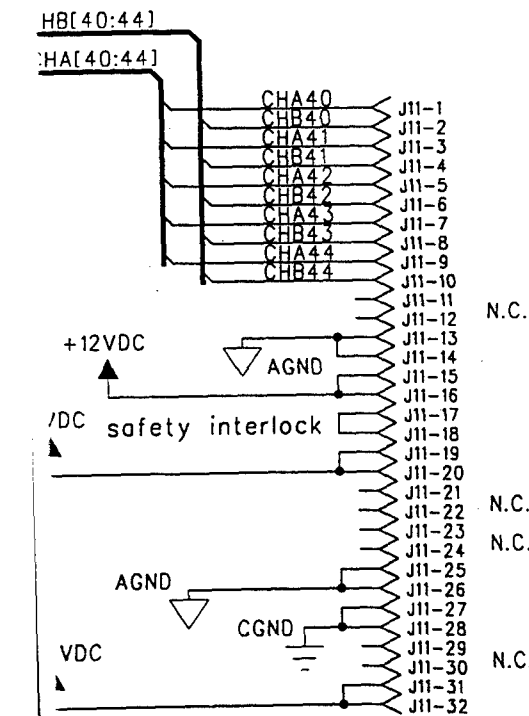
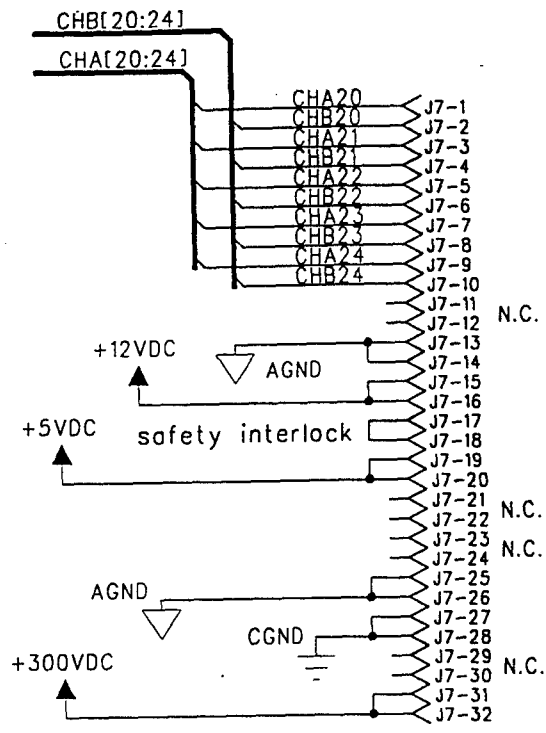
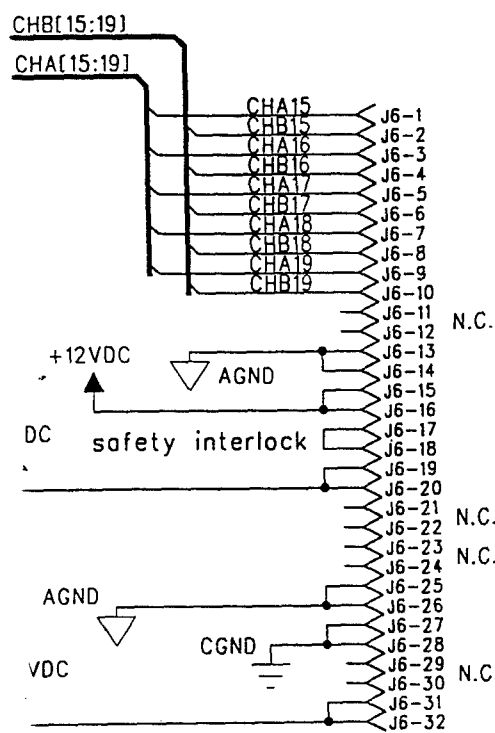

TP = Test Point
CGND = Chassis Ground
AGND = Analog Ground

3

 ELECTRONIC DESIGN LAB REDDING, CT 06896 (203) 938-2142	CLIENT DIMENSIONAL MEDIA ASSOC	
	PROJECT MOE DRIVER	REV
	MOE ELECTRONICS BACKPLANE	
	DRAWING BY MJA	DATE 10-20-97
DESIGN BY MJA		
JOB 601	DRAWING#	#: 2 OF 2