

UNCLASSIFIED

AD NUMBER

ADB809137

CLASSIFICATION CHANGES

TO: unclassified

FROM: confidential

LIMITATION CHANGES

TO:
Approved for public release, distribution unlimited

FROM:
Distribution authorized to DoD only;
Administrative/Operational Use; 1946.
Other requests shall be referred to Office
of Scientific Research and Development,
NRDC, Washington, DC.

AUTHORITY

Secretary of Defense memo dtd 2 Aug 1960;
OSRD ltr dtd 10 May 1966

THIS PAGE IS UNCLASSIFIED

UNCLASSIFIED

**SUMMARY TECHNICAL REPORT
OF THE
NATIONAL DEFENSE RESEARCH COMMITTEE**

This document contains information affecting the national defense of the United States within the meaning of the Espionage Act, 50 U.S.C., 31 and 32, as amended. Its transmission or the revelation of its contents in any manner to an unauthorized person is prohibited by law.

This volume is classified CONFIDENTIAL in accordance with security regulations of the War and Navy Departments because certain chapters contain material which was CONFIDENTIAL at the date of printing. Other chapters may have had a lower classification or none. The reader is advised to consult the War and Navy agencies listed on the reverse of this page for the current classification of any material.

**TECHNICAL LIBRARY
BLDG 313
ABERDEEN PROVING GROUND, MD.
STEAR-TL**

UNCLASSIFIED

UNCLASSIFIED

Manuscript and illustrations for this volume were prepared for publication by the Summary Reports Group of the Columbia University Division of War Research under contract OEMsr-1131 with the Office of Scientific Research and Development. This volume was printed and bound by the Columbia University Press.

Distribution of the Summary Technical Report of NDRC has been made by the War and Navy Departments. Inquiries concerning the availability and distribution of the Summary Technical Report volumes and microfilmed and other reference material should be addressed to the War Department Library, Room 1A-522, The Pentagon, Washington 25, D. C., or to the Office of Naval Research, Navy Department, Attention: Reports and Documents Section, Washington 25, D. C.

Copy No.

75

This volume, like the seventy others of the Summary Technical Report of NDRC, has been written, edited, and printed under great pressure. Inevitably there are errors which have slipped past Division readers and proofreaders. There may be errors of fact not known at time of printing. The author has not been able to follow through his writing to the final page proof.

Please report errors to:

JOINT RESEARCH AND DEVELOPMENT BOARD
PROGRAMS DIVISION (STR ERRATA)
WASHINGTON, 25, D. C.

A master errata sheet will be compiled from these reports and sent to recipients of the volume. Your help will make this book more useful to other readers and will be of great value in preparing any revisions.

UNCLASSIFIED

UNCLASSIFIED

SUMMARY TECHNICAL REPORT OF THE
APPLIED MATHEMATICS PANEL, NDRC

VOLUME 3

**PROBABILITY AND STATISTICAL
STUDIES IN WARFARE
ANALYSIS**

OFFICE OF SCIENTIFIC RESEARCH AND DEVELOPMENT
VANNEVAR BUSH, DIRECTOR

NATIONAL DEFENSE RESEARCH COMMITTEE
JAMES B. CONANT, CHAIRMAN

APPLIED MATHEMATICS PANEL
WARREN WEAVER, CHIEF

WASHINGTON, D. C., 1946

UNCLASSIFIED

NATIONAL DEFENSE RESEARCH COMMITTEE

James B. Conant, *Chairman*

Richard C. Tolman, *Vice Chairman*

Roger Adams	Army Representative ¹
Frank B. Jewett	Navy Representative ²
Karl T. Compton	Commissioner of Patents ³
Irvin Stewart, <i>Executive Secretary</i>	

¹Army representatives in order of service:

Maj. Gen. G. V. Strong	Col. L. A. Denson
Maj. Gen. R. C. Moore	Col. P. R. Faymonville
Maj. Gen. C. C. Williams	Brig. Gen. E. A. Regnier
Brig. Gen. W. A. Wood, Jr.	Col. M. M. Irvine
Col. E. A. Routheau	

²Navy representatives in order of service:

Rear Adm. H. G. Bowen	Rear Adm. J. A. Furer
Capt. Lybrand P. Smith	Rear Adm. A. H. Van Keuren
Commodore H. A. Schade	

³Commissioners of Patents in order of service:

Conway P. Coe	Casper W. Ooms
---------------	----------------

NOTES ON THE ORGANIZATION OF NDRC

The duties of the National Defense Research Committee were (1) to recommend to the Director of OSRD suitable projects and research programs on the instrumentalities of warfare, together with contract facilities for carrying out these projects and programs, and (2) to administer the technical and scientific work of the contracts. More specifically, NDRC functioned by initiating research projects on requests from the Army or the Navy, or on requests from an allied government transmitted through the Liaison Office of OSRD, or on its own considered initiative as a result of the experience of its members. Proposals prepared by the Division, Panel, or Committee for research contracts for performance of the work involved in such projects were first reviewed by NDRC, and if approved, recommended to the Director of OSRD. Upon approval of a proposal by the Director, a contract permitting maximum flexibility of scientific effort was arranged. The business aspects of the contract, including such matters as materials, clearances, vouchers, patents, priorities, legal matters, and administration of patent matters were handled by the Executive Secretary of OSRD.

Originally NDRC administered its work through five divisions, each headed by one of the NDRC members. These were:

- Division A—Armor and Ordnance
- Division B—Bombs, Fuels, Gases, & Chemical Problems
- Division C—Communication and Transportation
- Division D—Detection, Controls, and Instruments
- Division E—Patents and Inventions

In a reorganization in the fall of 1942, twenty-three administrative divisions, panels, or committees were created, each with a chief selected on the basis of his outstanding work in the particular field. The NDRC members then became a reviewing and advisory group to the Director of OSRD. The final organization was as follows:

- Division 1—Ballistic Research
- Division 2—Effects of Impact and Explosion
- Division 3—Rocket Ordnance
- Division 4—Ordnance Accessories
- Division 5—New Missiles
- Division 6—Sub-Surface Warfare
- Division 7—Fire Control
- Division 8—Explosives
- Division 9—Chemistry
- Division 10—Absorbents and Aerosols
- Division 11—Chemical Engineering
- Division 12—Transportation
- Division 13—Electrical Communication
- Division 14—Radar
- Division 15—Radio Coordination
- Division 16—Optics and Camouflage
- Division 17—Physics
- Division 18—War Metallurgy
- Division 19—Miscellaneous
- Applied Mathematics Panel
- Applied Psychology Panel
- Committee on Propagation
- Tropical Deterioration Administrative Committee

NDRC FOREWORD

AS EVENTS of the years preceding 1940 revealed more and more clearly the seriousness of the world situation, many scientists in this country came to realize the need of organizing scientific research for service in a national emergency. Recommendations which they made to the White House were given careful and sympathetic attention, and as a result the National Defense Research Committee [NDRC] was formed by Executive Order of the President in the summer of 1940. The members of NDRC, appointed by the President, were instructed to supplement the work of the Army and the Navy in the development of the instrumentalities of war. A year later, upon the establishment of the Office of Scientific Research and Development [OSRD], NDRC became one of its units.

The Summary Technical Report of NDRC is a conscientious effort on the part of NDRC to summarize and evaluate its work and to present it in a useful and permanent form. It comprises some seventy volumes broken into groups corresponding to the NDRC Divisions, Panels, and Committees.

The Summary Technical Report of each Division Panel, or Committee is an integral survey of the work of that group. The first volume of each group's report contains a summary of the report, stating the problems presented and the philosophy of attacking them, and summarizing the results of the research, development, and training activities undertaken. Some volumes may be "state of the art" treatises covering subjects to which various research groups have contributed information. Others may contain descriptions of devices developed in the laboratories. A master index of all these divisional, panel, and committee reports which together constitute the Summary Technical Report of NDRC is contained in a separate volume, which also includes the index of a microfilm record of pertinent technical laboratory reports and reference material.

Some of the NDRC-sponsored researches which had been declassified by the end of 1945 were of sufficient popular interest that it was found desirable to report them in the form of monographs, such as the series on radar by Division 14 and the monographs on sampling inspection by the Applied Mathematics Panel. Since the material treated in them is

not duplicated in the Summary Technical Report of NDRC, the monographs are an important part of the story of these aspects of NDRC research.

In contrast to the information on radar, which is of widespread interest and much of which is released to the public, the research on subsurface warfare is largely classified and is of general interest to a more restricted group. As a consequence, the report of Division 6 is found almost entirely in its Summary Technical Report, which runs to over twenty volumes. The extent of the work of a division cannot therefore be judged solely by the number of volumes devoted to it in the Summary Technical Report of NDRC; account must be taken of the monographs and available reports published elsewhere.

Perhaps the highest tribute which could have been paid to the role of mathematicians in World War II was the complete lack of astonishment which greeted their contributions. To the Applied Mathematics Panel of NDRC came urgent, varied, and formidable requests from every other group in NDRC and every military service. As expected, these requests were met; and, also as expected, the results were found invaluable in every phase of warfare from defense against enemy attack to the design of new weapons, recommendations for their use, predictions of their usefulness, and analysis of their effects.

To meet such obligations, the Applied Mathematics Panel under the leadership of Warren Weaver, together with members of its staff and of its contractors' staffs, made available the services of a group of men who were not merely able, competent mathematicians but also loyal, devoted Americans cooperating unselfishly in the defense of their country. The Summary Technical Report of the Applied Mathematics Panel, prepared under the direction of the Panel Chief and authorized by him for publication, is a record of their accomplishments and a testimonial to their scientific integrity. They deserve the grateful appreciation of the Nation.

VANNEVAR BUSH, Director
Office of Scientific Research and Development

J. B. CONANT, Chairman
National Defense Research Committee

FOREWORD

WHEN THE National Defense Research Committee was reorganized at the end of 1942, it was decided to set up a new organization, called the Applied Mathematics Panel [AMP], in order to bring mathematicians as a group more effectively into the work being carried on by scientists in support of the nation's war effort. At the time of the original appointment of the National Defense Research Committee by President Roosevelt, no mathematicians were included on the Committee, and it was not until the NDRC had been operating for more than a year that the need of a separate division devoted to applied mathematics was recognized. Although many of the operating Divisions of NDRC had set up mathematical groups to handle their own analytical problems, it was intended that the new Applied Mathematics Panel should supplement such groups and should furnish mathematical advice and service to all Divisions of the NDRC, carrying out requested mathematical analyses and remaining available as consultants after the original analyses had been completed. The Panel was organized too late to make possible a fully definitive trial of the success of this type of organization. That mathematics has a fundamental role to play in the science of warfare, I am sure; I have set forth some of the considerations which seem to me relevant and important in the last chapter of Volume 2 of the AMP Summary Technical Report.

The actual development of wartime scientific work proved to be such that the Applied Mathematics Panel has not only been called upon for assistance by NDRC Divisions but has also directly assisted many branches of the Army and Navy. Indeed, at the conclusion of hostilities, when approximately two hundred studies had been undertaken by the Panel, roughly one-half of these represented direct requests from the Armed Services. Furthermore, the consulting activities, growing out of studies originally undertaken to answer specific questions, turned out to be considerably more extensive and significant than was originally anticipated. I think that the importance of this phase of the work cannot be too strongly emphasized. But no account of such general consulting activities is given here, this report being restricted to the formally constituted studies.

The analytical work under AMP studies was carried on by mathematicians associated in groups at various universities and operating under OSRD contracts administered by the Panel. To the men who

served as technical representatives of the universities under these contracts, and to the technical aides who assisted the Chief in the administration of the Panel's scientific work, the Panel owes a large measure of whatever success it achieved. These men combined outstanding scientific competence with energy, resourcefulness, and a selfless willingness to devote their own efforts, as well as the efforts of their staffs, to the solution of other people's problems. The general plans for the Panel's activities were based upon the counsel of a group of eminent mathematicians, formally labeled the *Committee Advisory to the Scientific Officer*. This group, meeting every week and consisting of R. Courant, G. C. Evans, T. C. Fry, L. M. Graves, H. M. Morse, O. Veblen, and S. S. Wilks, had responsibility for the preliminary examination of requests which reached the Panel and for decisions on overall policy. The Chief relied heavily on their advice which, to a large extent, determined the effectiveness of the Panel's activities.

As the work of NDRC developed, the Panel was called upon for assistance by all of NDRC's nineteen Divisions. It is not, therefore, surprising that the scope of the Panel's activities covers a wide range, falling into four broad, though somewhat overlapping, categories:

1. *Mathematical studies based upon certain classical fields* of applied mathematics, such as classical mechanics and the dynamics of rigid bodies, the theory of elasticity and plasticity, fluid dynamics, electrodynamics, and thermodynamics.

2. *Analytical studies in aerial warfare*, including assessment of the performance of sights and anti-aircraft fire control equipment; studies relating to the vulnerability of aircraft to plane-to-plane and to anti-aircraft fire and the optimal defense of the airplane against these; and analyses of problems arising from the use of rockets in air warfare.

3. *Probability and statistical studies* concerned with the effectiveness of bombing; various aspects of naval warfare, including fire effect analysis and the performance of torpedoes; the design of experiments; sampling inspection; and analyses of many types of data collected by the Armed Services.

4. *Computational services* concerned with the evaluation of integrals; the construction of tables and charts; the development of techniques adapted to the solution of special problems; the nature and capabilities of computing equipment.

The work of the Panel in the first two of these

categories is summarized in Volumes 1 and 2 of the AMP Summary Technical Report. Volume 3, together with two monographs^a which the Panel has prepared dealing with sampling inspection and techniques of statistical analysis, provides a summary of the work in the third category. The fourth class of activities has been reported in AMP Note 25, *Description of Mathematical Tables Computed under the auspices of the Applied Mathematics Panel, NDRC*; in AMP Note 26, *Report on Numerical Methods Employed by the Mathematical Tables Project*; and in the reports published by the Panel under AMP Study 171, *Survey of Computing Machines*. No attempt has been made to report on work which will shortly be published as articles in scientific journals or on results which are deemed too special to be of continuing interest.

^a*Sampling Inspection and Techniques of Statistical Analysis*, published by McGraw-Hill Book Co., Inc.

The preparation of this Summary Technical Report was undertaken after the end of World War II, at a time when the members of the Panel's staff and of the contract groups were eager to return to their peacetime careers. Thus the preparation of these three volumes, solely for the purpose of recording for the Services, in easily accessible form the scientific results of the Panel's activities, was achieved at real personal sacrifice. I am greatly indebted to the authors of the several parts of these volumes and to the Editorial Committee, consisting of Mina Rees, I. S. Sokolnikoff, and S. S. Wilks, for the admirable job they have done in bringing together, under high pressure, a summary of the principal scientific accomplishments of the Panel.

WARREN WEAVER
Chief, Applied Mathematics Panel

P R E F A C E

THIS VOLUME furnishes a summary of the principal results of only a portion of the probability and statistical investigations made by the Applied Mathematics Panel during World War II. The work of the Panel in mathematical statistics may be classified into four major categories: (1) bombing accuracy studies, (2) development of statistical methods in inspection, research, and development work, (3) development of new fire effect tables and diagrams for the Navy, and (4) miscellaneous probability and statistical studies. As explained by the Chief of the Panel in his Foreword, the work done in category (2) has been declassified and is being prepared for publication in the form of two monographs; the work in category (3) has been transferred to a contract between Princeton University and the Navy for continuation, and many of the studies under category (4) are such that future interest in them is extremely limited.

Accordingly, the probability and statistical work of the Panel which is considered appropriate to summarize in Volume 3 of the Panel's Summary Technical Report consists of that in category (1) together with several studies in (4). Volume 3 is therefore divided into two parts, Part I: *Bombing Studies*, and Part II: *Miscellaneous Studies*.

The discussion and material presented in Part I—Chapters 1 through 5—is a résumé of the work of the Panel on the probability and statistical aspects of those bombing studies in which the Panel participated on a sufficient scale to warrant distribution of its own reports, memoranda, notes, and working papers. Because of the diverse interests and requirements of the organizations which initiated them, these studies relate to bombing operations of practically every kind, including such unusual items as air-to-air bombing, clearance of minefields, pitting of airfields, toxic-gas bombing, and controlled-missile bombing. In general, no attempt is made to cover activity carried out by Panel representatives acting as consultants for various agencies, some of which has been fully reported by these agencies. There are other omissions, notably, discussions of test programs, of operational and practice data, of odds-and-ends of theoretical investigations carried out by Panel personnel in conjunction with others. Many bombing accuracy investigations have been carried out by operational analysis sections and other groups in the Army and Navy, as well as British groups, but no attempt has been made in

this volume to integrate the work of the Panel into the entire field.

The work has been done at various stages of weapon and tactics development, ranging from that of pure a priori prognostication to that based fully on a posteriori assessment of combat operations. Work has rarely been done at the stage of the operations analyst, nor has it been practicable to do it at that stage. For, first, the Panel has not been in a position to obtain data as quickly as the operations analyst—indeed, the Panel has depended on the operations analyst as one of its prime sources of information; secondly, the Panel usually enjoyed more liberal time limits and better working facilities than did the operations analyst and hence could try for solutions to certain problems which were prohibitively formidable from the viewpoint of the analyst. Thus, there was virtually no duplication of effort between the Panel on the one hand and the various Operations Analysis Sections of the Army Air Forces and the Operational Research Group of the Navy on the other. It should not be inferred from these comments on time limits that the Panel work on bombing problems was a leisurely pursuit; the time limits, while generous compared to those faced by operations analysts, were very short when measured against the problems posed; indeed, deadlines frequently compelled that stop-gap solutions be sought, and, usually, the pressure of new work precluded an aesthetically satisfying clean-up of these problems.

The methodology of research varied from formal mathematical analysis, at one extreme, to synthetic processes and statistical experiments or models at the other. Formal analysis is the more precise and hence satisfying process, but the difficulties of formulating the problem in analytical terms and then (worse) of finding numerical solutions increase rapidly with the complexity of the bombing situation. For example, it is very easy to deduce almost all the probability consequences regarding the problem of aiming a single bomb at a rectangular target, but very few deductions can be made directly from the equations which describe the dropping of a train of as few as three bombs on a rectangular target. Since the problem of dropping a train of three bombs is itself extremely simple, compared to many common bombing operations, it is apparent that formal mathematical processes cannot alone be depended upon to carry the burden, but they are powerful when used in conjunc-

tion with synthetic methods and statistical models. These combined methods were being used more and more extensively and effectively toward the close of the war.

There has undoubtedly been some waste in the Panel's bombing research program, at least judged from the short-term viewpoint and with reference to the intended applications, for it occasionally happened that a great deal of effort was directed toward problems which had no large-scale counterpart in combat, i.e., toward problems which did not possess great potential yield compared to other unsolved problems. It is believed that this did not occur frequently, but it is annoying that it occurred at all. Part of it was unavoidable and may be ascribed to the natural waste of warfare. The real waste was incurred by continuing large-scale work after combat had clearly shown that quite different problems were of primary importance. This waste is attributable partly to the natural momentum of work under way and partly to insufficient liaison with the war theaters; the latter refers not only to the Panel's liaison, but to that of the agencies which requested studies of problems. This kind of difficulty was most pronounced in the early days of World War II; the situation improved with time as the Services' understanding of their needs increased and as the Panel's experience broadened to the point where it could better discriminate between merely unsolved problems and problems which were highly pertinent to current, projected, or likely operations.

The work of the Panel in bombing accuracy research was done by three research groups, namely, the Columbia University Bombing Research Group, the Princeton University Statistical Research Group, and the Statistical Laboratory of the University of California. The bombing research work of the Columbia group, under the direction of J. Schilt, consisted primarily in the computation of tables for the studies in train bombing and scatter bombing. The work of the Princeton group in bombing research, directed by J. D. Williams, consisted of a wide variety of investigations in pattern bombing, toxic gas bombing, air-to-air bombing, and so on. The California group, under the direction of J. Neyman, worked mainly on problems in area bombing, incendiary bombing, and to some extent train bombing. Members of these three Panel groups, and in particular the Princeton group, worked very closely with Army and Navy research groups interested in bombing problems. In fact, for periods varying from a few

months to nearly two years, members of these Panel groups acted as consultants on bombing accuracy problems to the following agencies: Army Air Forces Board; Proving Ground Command, Eglin Field, AAF; Combat Analysis Branch, Statistical Control Division, AAF; Navy Air Intelligence Group; Joint Army-Navy Target Group; Navy Operational Research Group; and Operational Analysis Division, Twentieth Air Force.

In Part II, Chapters 6, 7, and 8, a summary is presented of the principal results of the probability and statistical aspects of three torpedo studies, three land mine clearance investigations and an extensive statistical study of the performance of heat-homing devices. This is only a part of an extensive group of miscellaneous probability and statistical studies. The other studies in this category have been declassified or they are so highly specialized as to hold very little future interest, and hence are not included in Part II. The reader who might possibly be interested in such investigations can find brief accounts of the facts in the Panel's Final Summary Report of Projects.

The torpedo studies were done by the Columbia University Statistical Research Group and the remaining studies summarized in Part II were made by the Princeton University Statistical Research Group.

Except for a trivially small number of studies initiated by the Panel itself, all of the work summarized in this volume was requested by Army, Navy, or NDRC agencies. It would be difficult to give a list of all of the agencies with which the Panel had some contact with its probability and statistical research work described here, but the following, stated without reference to order, are the ones with which the Panel has had the greatest amount of association: Divisions 2, 3, 5, 7, 8, and 11 of NDRC; the Army Air Forces Board; the Joint Target Group; the Combat Analysis Branch, Statistical Control Division, AAF; the Proving Ground Command, AAF; the Armament Laboratory, Wright Field, AAF; the Ballistics Research Laboratory, Aberdeen Proving Ground; the Army Engineer Board; the Joint Army-Navy Experimental Testing Board; the Navy Air Intelligence Group; the Office of the Secretary of War; the Operations Analysis Divisions, Twentieth Air Force and USASTAF; the Navy Operational Research Group; and the Guided Missiles Committee of the Joint Chiefs of Staff.

The Panel is indebted to so many individuals in these agencies for information, counsel, and courte-

sics that it is highly impractical to attempt to list their names here.

In conclusion, the experience of the Panel in bombing accuracy analysis and closely related work as summarized in this volume indicates that this type of analysis is extremely effective in the development of weapons and tactics for their employment. It provides a powerful scientific method of evaluating the effectiveness of a weapon and improving it. Furthermore, it has become equally apparent from the Panel's experience that this analysis should be carried out in an orderly and integrated fashion all the way from the original conception of a new type of weapon to the use of this weapon in combat. Of course, in peacetime it is possible to follow the development of the weapon only through the field or proving ground testing stage. In this chain of development from conception to combat, there should be close coordination of the mathematical and statistical work on weapon accuracy and effectiveness at all stages, i.e., original design, development, early testing, advanced testing, production, and combat, as well as close coordination of the agencies involved—scientific, engineering, and military.

In view of the implications of the advent of the atomic bomb, a large amount of the type of accuracy analysis carried out for ordinary bombs becomes obsolete. This factor, however, serves essentially to change the emphasis of the work that needs to be

done from accuracy analysis of ordinary bombs, rockets, or gunfire with relatively small radii of effectiveness to that of controlled missiles of various kinds with extremely large radii of destruction, and the accuracy of defensive weapons against such missiles. It is believed that both the Army and Navy will do well to see to it that a carefully coordinated program of research of this type is set up and carried along in conjunction with the development of new weapons, whether they be slight variants of existing high explosive bombs or fantastic new controlled missiles with atomic payloads.

Finally, the editor of this volume wishes to express the thanks of the Panel and his own gratitude to J. D. Williams, Technical Aide of the Panel, for preparing the major portion of the volume, namely, Part I. He has done an excellent job under high pressure and a difficult deadline in bringing together a summary, necessarily rather highly condensed, of the principal accomplishments of the Panel in bombing research. He is uniquely qualified to do this work since he has played a central role in the Panel's bombing research work. Part II was prepared by the editor of the volume in consultation with various members of the Columbia University Statistical Research Group and the Princeton University Statistical Research Group.

S. S. WILKS
Editor

CONTENTS

CHAPTER	PAGE
Summary by <i>Warren Weaver</i>	1

PART I *BOMBING STUDIES*

1	General Considerations	9
2	Single-Release Bombing	14
3	Train Bombing	23
4	Pattern Bombing	46
5	Further Investigations	58

PART II *MISCELLANEOUS STUDIES*

6	Torpedo Studies	69
7	Statistical Studies in Mine Clearance	79
8	Statistical Analysis of the Performance of Heat-Homing Devices	88
	Bibliography	93
	OSRD Appointees	96
	Contract Numbers	97
	Service Project Numbers	99
	Index	101



SUMMARY^a

IN THIS Summary Technical Report of the Applied Mathematics Panel, a résumé is given of the principal scientific accomplishments of the Panel from its beginning in 1943 until the conclusion of hostilities. The activities here reported cover a wide range, dealing as they do with studies undertaken at the request of each of the nineteen Divisions of NDRC and of many branches of the Army and Navy. For the purpose of this report, that portion of the Panel's work which deals with specific military problems has been divided into three parts: Volume 1, *Mathematical Studies Relating to Military Physical Research*; Volume 2, *Analytical Studies in Aerial Warfare*; and Volume 3, *Probability and Statistical Studies in Warfare Analysis*. In addition to reporting on specific military problems, Volume 1 also indicates directions in which certain of the theories of fluid dynamics have been extended under AMP auspices as an aid in the planning and interpretation of military experiments, and in understanding the operation of enemy weapons. These three volumes contain no account of the new developments in statistical methods which have already been partially reported in a published article¹ and a published book² on sequential analysis, nor of certain important new applications of statistical theory which grew out of the Panel's attempt to solve problems presented to it by the Services. These latter are reported in two published monographs, *Sampling Inspection* and *Techniques of Statistical Analysis*, prepared under Panel auspices, which form part of the Panel's report of its technical activities. (Published by McGraw-Hill.)

Most AMP studies were concerned with the improvement of the theoretical accuracy of equipment by suitable changes in design; or with the development of basic theory, particularly in the field of fluid dynamics; or with the best use of existing equipment, particularly in fields like bombing and the barrage use of rockets. Two studies carried out under AMP auspices come closer to having general tactical or strategic scope than do most of the other work. I have myself given an account of these two studies in Part IV of Volume 2, where I have also set forth some incomplete and preliminary ideas of what a general analytical theory of air warfare could and should comprise and some arguments for and against

attempting to construct and use such a theory. I have there indicated how certain activities of the Applied Mathematics Panel and of other agencies relate to a scheme for a broad approach to the problems of air warfare and of warfare in general, and I have pointed out some of the contributions which mathematics can make to the field of national defense.

That part of the Panel's work which may be roughly described as classical applied mathematics is presented in Volume 1. Certain phases of this subject were developed under Panel auspices and adapted to problems of military interest, the principal emphasis being on problems of primary concern to the Navy.

In the early stages of the war, certain acoustic equipment employed in submarine detection by echo ranging used a "dome"—a streamlined convex shell filled with water or other liquid, such as oil. The presence of these domes caused interference with the directional pattern sent out from the projector, and in some of the equipment the disturbance was extremely serious. The Panel was asked to study the situation and to suggest changes in the domes which would minimize the disturbances. Practical conclusions were reached regarding desirable materials and design. It was found desirable for practical reasons to use thin shells reinforced by stiffening elements such as ribs and rods rather than to achieve strength by general thickness. Difficulties arising in direction finding due to annoying reflections were also analyzed, and suggestions were made for improving conditions, for example, by corrugations on the inner surface of the side walls of the domes. This dome study was one aspect of the work in wave propagation with which the Panel was concerned. There were others. For example, an investigation was made of the scattering of electromagnetic waves by spherical objects to assist in the analysis of smokes and fogs. A study of somewhat similar mathematical character (but dealing with electromagnetic disturbances rather than actual mechanical waves in a liquid) was undertaken at the request of the Fire Control Division (Division 7, NDRC), which had under development a predictor, the T-28, intended for use with the 40-mm gun. The computing mechanism used by this predictor included a sphere on which were placed electrical windings in such a way that the resulting field was one which corresponded to one simple dipole at the center of the sphere. Although

^aBy Warren Weaver

the theoretical way in which the winding should be distributed on the surface of this sphere was well known, it was necessary as a practical matter to substitute a winding in which the turns were located in grooves on the sphere. The formulas resulting from the Panel's study of this problem form a basis for practical applications which include ammeters, galvanometers, and direction finders. This mathematical study was of critical importance for the fire control instrument in question, for without it, it was impossible to obtain useful accuracy in the spherical "electromagnetic resolver" which carried out the essential steps in the target predicting process.

The Panel's work in gas dynamics, mechanics, and underwater ballistics is also reported in this first volume. The Panel's work in *gas dynamics* was principally concerned with the theory of explosions in the air and under water, and with certain aspects of jet and rocket theory. New developments were made in the study of shock fronts, associated with violent disturbances of the sort which result from explosions. An interesting and significant aspect of the work was concerned with Mach phenomena which frequently play a practical role in determining the destructive effects of shocks. For example, the advantages of air-bursting large blast bombs were suggested by a consideration of Mach waves. A request from the Bureau of Aeronautics for assistance in the design of nozzles for jet motors to be used for assisted take-off gave rise to an extended study of gas flow in nozzles and supersonic gas jets. As a result, suggestions were made not only for the design of nozzles for jet-assisted take-off, but also for "perfect" exhaust nozzles and compressors (of use in supersonic wind tunnels) and for various instruments to aid in rocket development and experimentation. The jet propulsion studies were related to Army and Navy interest in intermittent jet motors of the V-1 type. Jet propulsion under water was also studied, with results which should prove useful as a guide to experiment in this field where experimentation has thus far not reached the stage where the theoretical results can be fully put to test.

The problems in *mechanics* fall under two general headings: (1) those involving the mechanics of particles and rigid bodies and (2) those involving the mechanics of a continuum. For example, a study in the second category sought possible explanations of the break-up in cylindrical powder grains in the 4½-in. rocket to explain difficulties which were being encountered at the Allegheny Ballistics Laboratory, and an experimental program was outlined for the

testing of the most probable theories. One of the most interesting of the mechanical studies concerned the so-called spring hammer box used by the U. S. Navy in acoustic mine warfare. The dependence of the operation of this device on various physical parameters (for example, the mass of the hammer) was analyzed with the aid of a simple mechanical model, and of an electrical analog. Another problem of this type studied the dynamics of the gun equilibrator, or balancing system, when an Army gun was mounted on board a ship. The pitching and rolling of the ship naturally introduced special difficulties.

In the section on underwater ballistics, the problems involved are classified according to the various phases in the motion of the projectile: the impact phase, the development of the cavity, and the underwater trajectory. During the impact phase, forces act which are important partly because of their possible effects on the nose structure and mechanism of the projectile, partly because of their influence in determining the projectile's subsequent motion. It is during the impact phase that the greatest deceleration occurs. The theoretical analysis involves, among many other considerations, the direction of entry (vertical or oblique), and the shape of the projectile. Save when the speed of a missile is slow, its entry is accompanied by the formation of a cavity which becomes sealed behind the projectile and accompanies it to a greater or less extent during its underwater motion, influencing that motion in an important way. The underwater trajectory itself presents problems of great complexity. Frequently, slight changes in values of the parameters which determine the motion will cause a complete change in the type of motion. A mathematical discrimination among the several types of motion is made, part of the distinction depending on such things as the position of the center of gravity of the missile, the ratio of its length to its diameter, its density, its radius of gyration, and the manner of its entry. Throughout this treatment, an attempt has been made to integrate into a single report the results which have been obtained by the many agencies concerned with the several phases of the problem and thus to assist the theoretical and experimental studies which must be carried forward in future attempts to understand this difficult array of problems.

Many of the studies reported in Volume 2, as well as those contained in Volume 3, involve probability considerations, a field which is notoriously tricky and within which "common sense" is often quite helpless.

For example, what is the optimum mixture of armor-piercing and incendiary ammunition for the rear guns of a bomber? Specifications often designate such mixtures as five AP to two incendiary (we are neglecting tracers here). Why? The somewhat striking, and by no means obvious, fact is that, given any fixed type of target, it is better to have either *all* AP or *all* incendiary, depending on the nature of the target. The justification for any other intermediate mixture should be based on knowledge of the relative probability of encountering different targets, certain of which would be more vulnerable to AP and others more vulnerable to incendiary. This conclusion was reached as an incidental result of a study which was concerned with alternative fighter-plane armament and which arose out of the enthusiasm of a few persons associated with the Panel for two papers attributable to L. B. C. Cunningham, Chief of the Air Warfare Analysis Section in England, and his associates. Another study concerned with the practical effectiveness of equipment grew out of a request to NDRC from Headquarters, AAF, asking for collaboration with the AAF "in determining the most effective tactical application of the B-29 airplane." The results of this study, obtained on the basis of large-scale experiments in New Mexico and small-scale optical experiments by the Mt. Wilson Observatory staff at Pasadena, were concerned principally with the defensive strength of single B-29's and of squadrons of B-29's against fighter attack, and the effectiveness of fighters against B-29's. One indirect result of the optical studies was a set of moving pictures showing the fire power variation of formations as a fighter circles about them. Concerning such pictures the President of the Army Air Forces Board remarked that he "believed these motion pictures gave the best idea to airmen as to the relative effect of fire power about a formation yet presented." Certain of these pictures were flown to the Marianas and viewed by General Le May and by many gunnery officers at the front.

These two studies are reported in the last part of Volume 2. The first three parts of this volume report on special and detailed problems which arise when shots are fired against targets moving in the air or on the ground. The problem of shooting from an aircraft in motion against an enemy aircraft or against a ground target in motion and the problem of shooting from the ground or from a naval craft against an enemy aircraft all involve a number of considerations.

1. Whenever the target is in motion, its position at

the instant of firing is different from its position at impact, if impact occurs. For an effective shot, the motion of the target during the time of flight of the bullet or rocket or shell must therefore be predicted, at least approximately. The special character of this problem for the special cases which have come under the Panel's study are discussed for air-to-air warfare in Part I, for rocket fire from the air in Part II, and for ground or ship based antiaircraft fire in Part III.

2. When one's own ship is in motion, the apparent motion of the target is affected.

3. There are oscillations in aim as the gunner attempts to point continuously at the target. These oscillations are greater in air-to-air and in ship-to-air than in ground-to-air gunnery because of the vibrations, rotations, and bumpy motions of one's own ship.

4. There is the effect of gravity on the bullet. In air-to-air gunnery, for the short ranges used in World War II, this was of minor importance, but for rocket fire it introduced very considerable complications.

5. The resistance of the air varies with the altitude. Thus, at 22,000 feet above sea level the air is half as dense as it is at sea level. This will affect the average speed of a bullet, hence its time of flight, and hence the prediction referred to above.

A large part of Volume 2 is devoted to problems connected with so-called flexible gunnery, i.e., with the aiming of those guns, carried on aircraft, which can be pointed in various directions with respect to the aircraft (as contrasted with fixed guns in the wings or nose, which are aimed only by movement of the aircraft). In January 1944, Brigadier General Robert W. Harper, AC/AS (Training), wrote in a letter to Dr. Vannevar Bush, Director of OSRD, that "the problems connected with flexible gunnery are probably the most critical being faced by the Air Forces today. It would be difficult to overstate the importance of this work or the urgency of the need; the defense of our bomber formations against fighter interception is a matter which demands increasing coordinated expert attention." This situation arose because of the inadequate training and inadequate deflection rules given to the gunners who had to handle ring sights in bombers. The "relative speed" and "apparent motion" rules currently taught were not thoroughly learned by the gunners and in many cases were by no means adequate when they were properly applied. There were well authenticated cases of gunners who "led" the attacking fighters in a direction exactly opposite to that of the true lead!

The immediate proposal contained in General

Harper's letter was that the Applied Mathematics Panel should recruit and train competent mathematicians who had the "versatility, practicality, and personal adaptability requisite for successful service in the field;" it was planned that these men, after two months' training in this country, would be assigned to the Operations Research Sections in the various theaters to devote their attention to aerial flexible gunnery problems. The Panel was in a position to carry out this program because it had already been drawn into studies of rules for flexible gunnery training and because it had access to many of the ablest young mathematicians in the country. The assignment was completed promptly, and, as a partial result of this undertaking, the Panel found itself even more closely in touch with the Operations Analysis Division of the AAF (with which it had already established cordial working relations) and with the AAF Central School for Flexible Gunnery. Around this interest and the interest of the Army, the Navy, Division 7, and Division 14 in the improvement in the effectiveness of guns as well as gunnery, grew up a very considerable body of knowledge and experience which is reported in Part I of Volume 2. Here an attempt is made to bring together into a single account the state of the art of air-to-air gunnery, not only as that has been affected by the work of the Applied Mathematics Panel, but as it has reflected the activities of agencies in this country and abroad. The topics discussed are:

1. The motion of a projectile from an airborne gun, constituting that branch of exterior ballistics which is called *aeroballistics*.

2. A mathematical *theory of deflection shooting* considered first for the case of a target moving at constant speed on a straight line which lies in a plane with the gun-mount velocity vector; second, for a target which moves in a curved path; and third, for the case where mount and target move in arbitrary space paths.

3. *Pursuit curve theory*. Pursuit curves were important in World War II, since the standard fighter employed a heavy battery of guns so fixed in the aircraft as to fire sensibly in the direction of flight. Thus it was necessary to fly on such a correctly banked turn that a correct and changing aiming allowance was continuously made. This pursuit curve theory is also of importance in the study of guided missiles which continuously change direction under radio, acoustic, or optical guidance unwillingly supplied by the target.

4. The design and characteristics of *own-speed sights* which were introduced as devices designed for use against the special case of pursuit curve attack on a defending bomber. Simple charts which might be used in the air are given, based on optimum rules for determining deflection against an aerodynamic pursuit curve.

5. *Lead computing sights* which do not assume that the fighter is coming in on a pursuit curve but which basically assume that the target's track relative to the gun mount is essentially straight over the time of flight of the bullet. The mechanical sights of the Sperry series are considered in some detail.

6. The basic theory of a *central station fire control system*.

7. The analytical aspects of experimental programs for *testing airborne fire control equipment*. It is recognized that field tests, laboratory tests, and theoretical analyses all have an important place in such a program. Instrumentation for tests, reduction of data, measures of effectiveness, and optimum dispersion are discussed.

8. *New developments*, such as stabilization and the use of radar.

The second part of Volume 2 is devoted largely to a presentation of the results obtained by the Panel in a study intended to determine what sighting methods are feasible for airborne rockets. The essential problems involved in this question have to do with ballistic formulas, attack angle and skid, the effect of wind and target motion, how these various factors affect each proposed sighting method, and how tracking affects and is affected by them.

In Part III of Volume 2 certain special studies of antiaircraft equipment which were made under AMP auspices are discussed, and a report is given of the *flak analysis* and other *fragmentation and damage studies* carried on by the Panel. This report is concerned with some mathematical problems which arise in attempts to estimate the probability of damage to an aircraft or group of aircraft from one or many shots from heavy antiaircraft guns. Related problems arise in air-to-air bombing and in air-to-air or ground-to-air rocket fire, but the major part of the mathematical analysis so far performed has been devoted to problems of flak risk. The emphasis in the discussion is on the description of a method for treating problems of risk, since specific numerical conclusions are likely to become obsolete before further need for them arises, while the techniques by which the results were obtained will be useful as long as

weapons which destroy by means of flying fragments are in use. The original experimental information on which the Panel computations were based came from a variety of sources, principally Army, Navy, OSRD, and British reports. The Panel's chief contribution was the development of computational techniques which could be carried through before the project became obsolete, the selection of pertinent examples, and the applications of the computational techniques to the selected examples. Certain applications of the underlying theory to time-fuzed and proximity-fuzed shells, and to proximity-fuzed rockets are here reported.

Another major field of effort in the work of the Panel is that of *Mathematical Statistics*, reported in Volume 3. A remarkably wide variety of probability and statistical investigations was carried out by the Panel. These investigations ranged from the development of sampling inspection plans in connection with procurement of military matériel to extensive statistical analyses of combat data. Of the Panel's 194 studies, 53 related to problems in probability and statistical analysis.

The work of the Panel in mathematical statistics can be grouped into the following major categories:

1. *Bombing accuracy* research.
2. *Development of statistical methods* in inspection, research, and development work.
3. Development of new *fire effect tables* and diagrams for the Navy.
4. *Miscellaneous studies* relating to spread angles for torpedo salvos, lead angles for aerial torpedo attacks against maneuvering ships, land mine clearance, performance of heat-homing devices, search problems, verification of weather forecasting for military purposes, procedures for testing sensitivity of explosives, distribution of Japanese balloon landings, etc.

Of these four main categories of work, category 1 required by far the greatest amount of energy. This activity had its beginning in a fairly small study undertaken for the Armament Laboratory, Wright Field, on the design of a computer for determining the optimum spacing of bombs in a train of bombs dropped from a bomber in attacking a given target under specified conditions. The study was started in 1942 under Division 7, NDRC, and was transferred to the Panel when the Panel was organized. In pursuing this study the group working on it came in contact with individuals in more than a dozen Army, Navy, and NDRC groups interested in bombing accuracy problems. As the war progressed, an increas-

ing number of requests came from these groups for studies of all kinds of accuracy and coverage problems arising in train bombing, area bombing, pattern bombing, guided-missile bombing, incendiary bombing, and so on. By the end of the war the work in this field had grown to the point where the major effort of three Panel research groups was being spent on nineteen studies dealing with probability and statistical aspects of bombing problems.

The methods and results developed in category 2 are of much broader interest than that associated with their wartime applications. During the war, it was recognized by the Services that the statistical techniques which were developed by the Panel for Army and Navy use, on the basis of the new theory of sequential analysis, if made generally available to industry, would improve the quality of products produced for the Services. In March 1945, the Quartermaster General wrote to the War Department liaison officer for NDRC a letter containing the following statement:

By making this information available to Quartermaster contractors on an unclassified basis, the material can be widely used by these contractors in their own process control and the more process quality control contractors use, the higher quality the Quartermaster Corps can be assured of obtaining from its contractors. For, by and large, the basic cause of poor quality is the inability of the manufacturer to realize when his process is falling down until he has made a considerable quantity of defective items. . . . With thousands of contractors producing approximately billions of dollars' worth of equipment each year, even a 1% reduction in defective merchandise would result in a great saving to the Government. Based on our experience with sequential sampling in the past year, it is the considered opinion of this office that savings of this magnitude can be made through wide dissemination of sequential sampling procedures.

On the basis of this and similar requests, the Panel's work on sequential analysis was declassified, and the reports mentioned above were published. The Quartermaster Corps reported in October 1945 that at least 6,000 separate installations of sequential sampling plans had been made and that in the few months prior to the end of the war new installations were being made at the rate of 500 per month. The maximum number of plans in operation simultaneously was nearly 4,000.

Thus extensive use was made by the Army of sequential analysis as a basis for sampling inspection. It was at the request of several Navy bureaus that the Panel undertook to assemble a manual setting forth procedures to be used not only with sequential sampling but also with single and double sampling

plans. As an extension and expansion of this manual, the Panel undertook the preparation of its monograph, *Sampling Inspection*. The monograph, *Techniques of Statistical Analysis*, presents a variety of statistical methods which have been developed, or adapted from more general methods, for dealing with various statistical problems which have arisen in connection with research and development work.

The work done in category 3 was of highly specialized long-range interest to the Office of the Commander in Chief of the U. S. Fleet. After the work had been carried forward under the direction of the Panel for nearly two years, arrangements were made to transfer and continue the work under a contract, effective June 1, 1945, between the Navy and Princeton University. During the time this work was under the Panel's direction, a series of nine basic reports was submitted to the Navy. None of this work, which was only partially completed under the direction of the Panel, is reported upon in the Panel's Summary Technical Report.

Certain of the studies in category 4 are of such limited interest that it has been considered neither appropriate nor worth-while to report upon them here. Accounts are given of the work which relates to torpedoes, land mine clearance, and the performance of heat-homing devices.

An important adjunct of the probability and statistical work of the Panel was a statistical consulting service for various Army, Navy, and NDRC agencies. Although some of this consulting was done in connection with formal AMP studies and projects in such a way that the results are adequately reported in original Panel reports or the Panel's Summary Technical Report, a large fraction of it was informal and the results of it are to be found in reports and memoranda of many agencies, particularly Divisions 2, 5, 8, and 11 of NDRC; Joint Army-Navy Target Group, Army Air Forces Board; Proving Ground

Command, Eglin Field, AAF; Operational Analysis Division, Twentieth Air Force, AAF; Combat Analysis Unit, Statistical Control, AAF; Office of the Quartermaster General; Navy Air Intelligence Group; Navy Operational Research Group; and the Guided Missile Committee of the Joint Chiefs of Staff.

Men from several of the Panel's research groups acted as consultants to these various agencies for periods ranging from two months to two years. In my opinion some of the most useful service which the Panel was able to render came about through the work of these men in their capacities as consultants; the effectiveness of this work increased constantly until the end of the war. The work of these men varied widely: assistance in setting up sampling inspection plans for procurement of matériel, helping in the introduction of a quality control system in rocket production, working on designs of experiments for toxic gas bombing, testing controlled missiles, cooperation in the preparation of an incendiary manual, and dozens of other projects.

I cannot leave the topic of mathematical statistics without emphasizing the powerful yet severely practical role which this relatively young branch of applied mathematics has played in the work of the Panel. The tools of the probabilist and statistician have been applied to an almost unbelievably wide array of problems. Probability analysis played a fundamental part in a priori investigation of various kinds of weapons and tactics studied by the Panel. As the war progressed and these weapons and tactics were tested at the proving ground and tried out in combat, the analysis of the observational data became primarily statistical. The work of the Panel surely indicates that the Army and Navy will do well in their research, development, and testing of weapons and tactics to see to it that the tools of the mathematical statistician are not overlooked.

PART I
BOMBING STUDIES

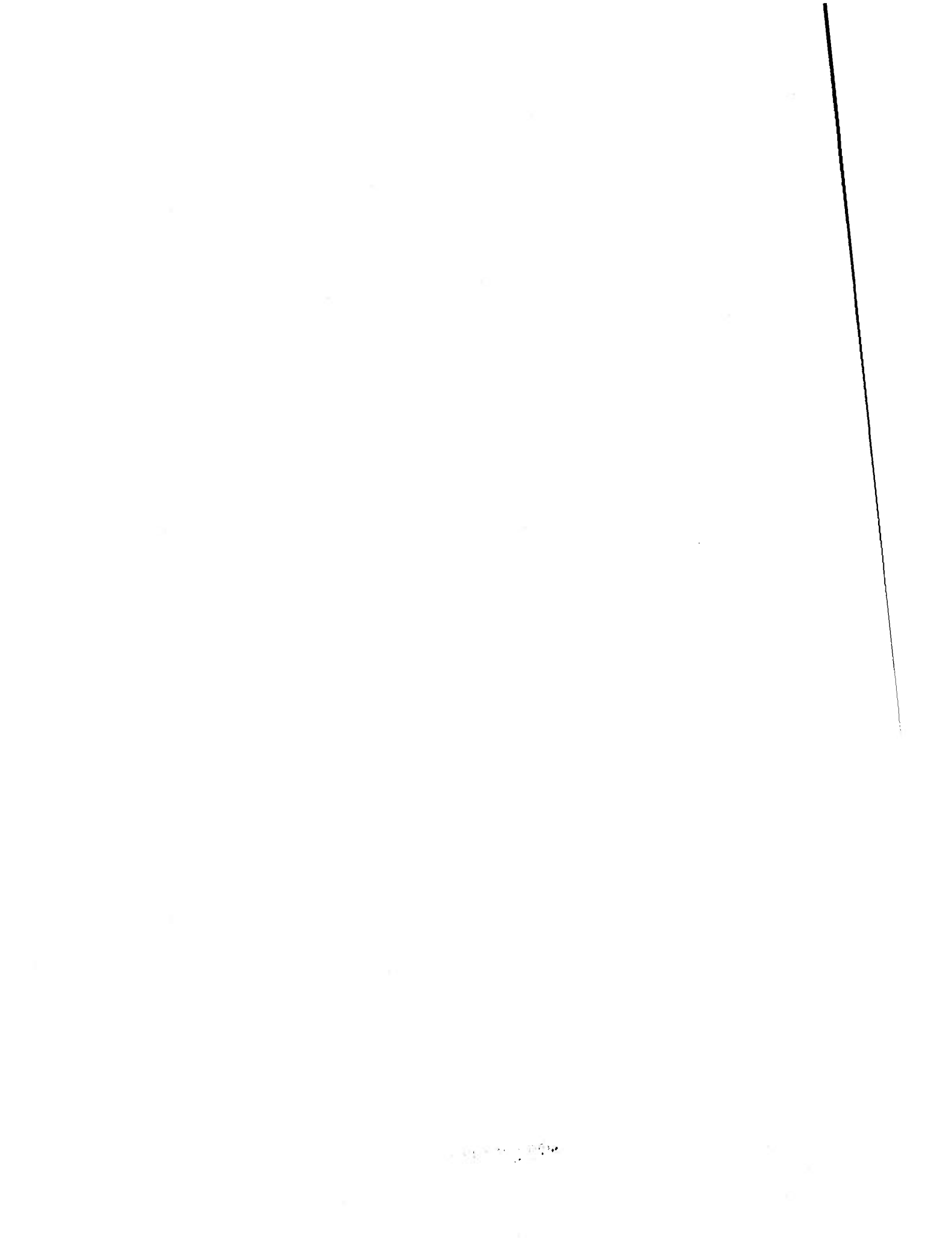

Chapter I

GENERAL CONSIDERATIONS

1.1 INTRODUCTION

IN CHAPTERS 1 to 5 are presented the principal results of probability and statistical studies of various bombing problems which have been carried out by the Applied Mathematics Panel [AMP]. It has proved difficult to choose an order of presentation which is consistent and logical, for there does not appear to be a completely natural order. The order finally chosen is a somewhat artificial one suggested by operating conditions in World War II. For example, if the basic assumptions underlying an investigation are such that they are at present most nearly realized in single-release bombing, the topic is discussed under that heading, and similar groupings of investigations are used for train and pattern bombing. A weakness of the scheme lies in the fact that the assumptions which accurately characterize one situation often constitute a useful idealization of quite a different operational problem; furthermore, in a number of instances the position of a study has been assigned almost arbitrarily. In view of this, it is recommended that the interested reader scan sections in addition to those which are obviously germane to his immediate problem.

1.2 THE BOMBING PROBLEM

In probability and statistical studies of bombing problems the two fundamental constituents are:

1. The *target*, which comprises a set of areas. In particular, it may be a single area and this may be, effectively, a point. The configuration is usually given.

2. The *bomb fall*, which comprises a set of impact areas. In particular, as in the case of the target, it may be a single area and this may be, effectively, a point. The configuration may or may not be fixed; if it is not, there can be any degree of statistical or geometrical dependence between the components of the bomb fall.

The first decision in solving a bombing problem involves the choice of an appropriate probability statement regarding the relationship between the target and the bomb fall. For example, it may be desired to know the proportion of the target which will, on the

average, be blanketed by the bomb fall, or to know the proportion of the bomb fall which will be contained within the target, or to know the probability that the target will be hit at least a specified number of times, or to know the probability that at least a specified number of target elements will be hit.

Making the best objective choice of the measure to use is one of the two truly difficult parts of the bombing problem, the other being to design tactics which are operationally feasible. Once the statistic which will measure success has been selected and the general domain of feasible tactics entered, it is simply a matter of technique and craftsmanship to arrive at some specific answers as expeditiously as possible. In the first part of the problem the military man is usually extremely weak and in the second part the scientist is usually extremely weak; in fact, they need each other more than either usually thinks.

There are many occasions when a thorough appreciation and knowledge of strategic plans, such as can only be supplied by military personnel, is needed in order to arrive at the proper formulation of the statement. For example, a uniquely important target, say the *von Tirpitz*, or a heavy-water plant, would require a different approach than would a campaign against an industry, say that of synthetic oil, even when the crucial installations are the same size as that of the unique target. Again, the proper statement may change as the result of changes in Air Force technique. For example, the early visual bombing operations in the European Theater of Operations were so ragged that there was little question that the average proportion of bomb fall contained within the target was a reasonable measure of performance, and that the performance could stand vast improvement. However, toward the end of the war, as a consequence of increased bomb loads and improved technique, there was some question whether preoccupation with the average proportion of hits was not leading, at least on occasion, to over-bombing, and whether one should not replace this criterion with a new one, say the number of target elements or cells hit. This particular issue is controversial, but the fact that it is controversial suggests that the operations may actually have been nearing a point where a re-evaluation of the criterion was in order.

1.3 DIGRESSION ON TWO STATISTICS

Although a full discussion of the two statistics briefly described here is beyond the scope of the present volume, it may not be inappropriate at this point to comment briefly on two criteria. In order to exemplify some of the considerations which enter the bombing problem, let us consider (1) the probability, say P_k , of at least k hits on a target, and (2) the expected number, say E , of hits on a target. The necessity to choose between these two criteria arises frequently.

Denoting by P'_k the probability of exactly k hits and by n the number of bombs, the two criteria are defined respectively, as follows.

$$P_k = \sum_{i=k}^n P'_i, \quad (1)$$

$$E = \sum_{i=1}^n iP'_i, \quad (2)$$

where P_k is the sum of certain P'_i 's and E is the weighted sum of all the P'_i 's from $i = 1$ to $i = n$, the weights being i . Thus, P_k assigns equal importance to any number of hits greater than or equal to k , whereas E values the hits according to their number.

Hence, it appears that to choose between the criteria, one must judge (1) that the situation is such that less than k hits has relatively little value and that more than k hits has little value in excess of that associated with k , in which case P_k is a desirable criterion, or (2) that the value of the operation is almost proportional to the number of hits, in which case E is a desirable criterion.

But this ignores the question of reliability of performance, which is best illustrated by reference to a special case, i.e., the comparison of P_1 and E , for here it is easy to demonstrate the point. Referring to equations (1) and (2), one observes that the first is, in this instance, the simple sum and the second the weighted sum of the same P'_i 's ($i = 1, \dots, n$). Suppose one seeks to maximize one of these expressions, say the one on the right of equation (2). Since the expression on the right of equation (1) will not, in general, be simultaneously maximized, it follows that the use of the criterion E , which leads to the greatest number of hits, in the long run will cause an unnecessarily large number of missions to be complete failures, since P_1 , which asks only that

there be some hitting, is smaller than it need be. Similarly, if P_1 is maximized, in the long run the total number of hits will be unnecessarily small.

But the choice between P_k and E may not be easy to make without further quantitative study. For example, suppose it is quite certain that E is the primary interest, but that completely sterile missions, i.e., missions in which there is no hitting, are somewhat undesirable from other viewpoints, such as morale. It may occur that the conditions which maximize E are very unfavorable for P_k , whereas those which maximize P_k are very nearly as good from the viewpoint of E as are the optimum conditions for the latter. In the train-bombing case illustrated by Figure 16 of Chapter 3, the use of the maximum- E criterion will reduce P_1 from a possible 0.110 to 0.015. On the other hand, if P_1 is maximized instead of E the cases of some hitting are increased more than sevenfold, while E falls below its maximum by but a few per cent. In this case the use of P_1 seems preferable to the use of E , even though the long-term number of hits is highly valued.

The criteria, P_k and E , are not the only possible ones of course. The problem of ship-sinking probabilities, discussed in Section 3.7 under *Method of Analysis*, illustrates another alternative. The ideal criterion, when the choice revolves about P_k and E , probably is a weighted sum of all P'_i 's, namely,

$$\sum_{i=0}^n c_i P'_i, \quad (3)$$

in which the c_i 's reflect accurately the value of i hits, including $c_0 < 0$ which measures the disadvantage of complete failure.

1.4 THE MATHEMATICAL MODEL FOR CALCULATION

Once the appropriate probability statement has been selected, the next step is to invent the mathematical model, or idealization, which will be employed for calculation. Here the desire to introduce as much realism as possible must be tempered by the knowledge that, unless complexities are built in with care, they will cause the labor of calculation to balloon seriously. Generally, increasing the accuracy of a model is more costly than increasing the precision of calculation, and of course the latter is not inexpensive. There are, unfortunately, situations in which certain of the probability expressions must be

determined quite realistically and within close limits, for example, when the quantities in question must be raised to high powers to obtain the final expression.

After the model is chosen, it is usually necessary to explore, via calculation, a substantial region in the parameter space in order to gain a sufficient and useful appreciation of the behavior of the function. The purpose of this exploration is twofold: (1) to discover whether the results depend sensitively on the parameters of the model, and (2) to discover which of the operationally controllable factors can most profitably be modified, and to forecast the value of attainable modifications; alternatively, if the situation is completely new, its probable worth compared to existing situations may be estimated.

The problem has been stated with considerably more generality than is useful in the applications, for even when the type of probability statement is agreed upon, the description of the general target and bomb-fall complexes mentioned earlier requires more parameters than it is feasible to introduce in a reasonable computing program. Since a description of the target and bomb-fall complexes, which would include both the shapes and positions of the regions, is extremely difficult, the problem must be attacked piecemeal. Moreover, one must become reconciled to solving only those cases to which the greatest interest attaches, for even the less general cases are often tedious.

The target and bomb-fall complexes treated in the various sections of the following chapters are specialized in so many different ways that few comprehensive observations can be made regarding them. The same is true of the probability statements incorporated in the various studies; they are too varied, in accordance with the needs of the immediate problems attacked, to fit into a summing-up statement.

1.5 THE AIMING-ERROR DISTRIBUTION

One element, however, is common to the great majority of the investigations and warrants some discussion. This element is the distribution of aiming errors. The distance from the intended mean point of impact [MPI] to the centroid of each independently aimed bomb fall is assumed to be a random vector from a two-dimensional Gaussian distribution. The dispersion of aim may or may not be the same in range as in deflection; the components may or may not be correlated; the intended MPI, or long-term average position, may or may not be at target center. This much latitude and variation occurs, but

otherwise the assumption regarding aiming-error distribution is fixed. Practically every investigation intended for direct application to bombing is based on the assumption that the aiming-error distribution is Gaussian, or normal. It is pertinent and important, therefore, to comment on this assumption.

There is abundant evidence from practically every type of bombing operation—practice and combat, single-release and pattern, conventional bomb and controlled missile, visual and radar sighting—which shows that bombing errors are not normally distributed and, in fact, from some viewpoints, that the Gaussian is not a particularly good approximation to the actual distribution.

Empirical bombing distributions usually have too many large deviations, measured from the mean, compared to normal distributions. These empirical distributions generally can be represented as the sum of two component distributions, of which at least one is normal, and this normal component usually comprises the major portion of the data. In fact, usually three-fourths or more of the observations fall in this category. The other component distribution, which, since it is often weakly represented and always unwelcome, may be called the contaminating distribution, plays a role of varying importance depending on whether the investigation is largely a priori or largely a posteriori. Some of the consequences of each type of investigation will be examined.

In many bombing problems it is of vital importance that the probability density in the neighborhood of the intended MPI, usually at target center, be reliably estimated, since the important target is often small and situated there. Suppose that, predominantly, the aiming errors, x and y , in range and deflection, respectively, may be represented by the circular-Gaussian density function centered at the intended MPI

$$\rho = \frac{1}{2\pi\sigma^2} e^{-(1/2\sigma^2)(x^2+y^2)}, \quad (4)$$

where σ is the standard deviation of aiming error in range or deflection, but that a fraction, say α , of the aimings are associated with some other density function. For the sake of an explicit example, let this too be a normal density function, centered at the intended MPI with standard deviation, $\sigma' = r\sigma$. Then the true density in the neighborhood of the origin is

$$\rho = \frac{1 - \alpha + \frac{\alpha}{r^2}}{2\pi\sigma^2}. \quad (5)$$

Suppose that an a priori investigation is undertaken and that the presence of the dominant distribution equation (4) is recognized and its standard deviation estimated to be σ_a , but that the contamination is not suspected, the estimated density might be

$$\rho_a = \frac{1}{2\pi\sigma_a^2}. \quad (6)$$

Now consider an a posteriori investigation in which one is presented with data, from s actual bombing operations, subject to the density law equation (4) plus a contamination term. Suppose again the existence of the contamination is not recognized and that one is willing to assume that the data are subject to a circular-Gaussian law. Suppose that the variance, σ^2 , is estimated from the s observations by efficient processes, e.g., by

$$\hat{\sigma}^2 = \frac{1}{2s-2} \left[\sum_{i=1}^s (x_i - \bar{x})^2 + \sum_{i=1}^s (y_i - \bar{y})^2 \right], \quad (7)$$

where \bar{x} and \bar{y} are the sample averages of the coordinates x and y . The expected value of this statistic,

$$E(\hat{\sigma}^2) = [1 - \alpha + \alpha r^2] \sigma^2, \quad (8)$$

indicates that the density estimate would be approximately

$$\rho_e = \frac{1}{2\pi\sigma^2} [1 - \alpha + \alpha r^2]^{-1}. \quad (9)$$

Taking the ratios of estimated to true density for the hypothetical a priori and a posteriori cases, i.e., equation (6) and equations (5) to (9), one finds

$$\frac{\rho_a}{\rho} = \frac{\sigma^2}{\sigma_a^2} \left(1 - \alpha + \frac{\alpha}{r^2} \right)^{-1}, \quad (10)$$

$$\frac{\rho_e}{\rho} = \left(1 - \alpha + \frac{\alpha}{r^2} \right)^{-1} \left(1 - \alpha + \alpha r^2 \right)^{-1}.$$

Even if the amount of contamination α and the relative magnitude r of its standard deviation are modest, ρ_e may be in error by a substantial factor. For example, with $\alpha = 0.1$ and $r = 5$, $\rho_e/\rho = 0.325$, i.e., ρ_e is in defect by a factor greater than 3.

The situation is illustrated in Figure 1 for a random sample of $s = 20$ items drawn from a circular-Gaussian population with standard error σ ; the arrows indicate the shifts which would affect the last two items drawn ($\alpha = 0.1$) if they were from a contaminating distribution in which $\sigma' = 5\sigma$.

The moral of the example is twofold: (1) that an a priori investigation is not seriously prejudiced by virtue of being based on the assumption of normality

when, in fact, the distribution is contaminated, and (2) that, in a posteriori evaluation of bombing data, an uncritical acceptance of the hypothesis of normality may result in very and unnecessarily poor estimates of aiming errors.

The question as to how such data may best be handled deserves more study than it has received to date. The task of decomposing an observed distri-

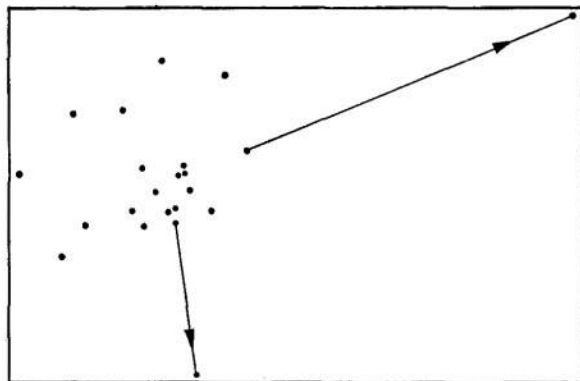

FIGURE 1. A random sample of 20 observations from a circular-Gaussian distribution with standard deviations of σ . The translations, indicated by arrows, show the change which takes place when the last two observations are drawn from a Gaussian distribution with standard deviation 5σ .

bution into component distributions, and of making unbiased, efficient estimates of their parameters, offers difficulties. It is, moreover, unsatisfying labor when the sample is small, as is so frequently the case. A technique which is rapid, and leads to unbiased estimates of probability, but is quite inefficient, is the following: Superpose the bomb fall on the target T of interest and count the hits. If there are H of these then the ratio $p = H/s$ is an unbiased estimate of the probability of hitting. Now assume that the distribution is normal and set

$$\frac{H}{s} = \frac{1}{2\pi\sigma^2} \iint_T e^{-(1/2\sigma^2)(x^2+y^2)} dx dy. \quad (11)$$

On solving for σ one obtains a value which can be used safely for calculating probabilities of hitting targets which do not differ radically from the T used in equation (11). But as mentioned above, the reliability of these estimates is often not as great as could be desired from a sample of s observations.

1.6 TERMINOLOGY AND NOTATION

The results summarized in the following chapters of Part I have been worked out over a period of

several years by a large number of individuals. The terminology and notation which appear in the original papers are quite naturally not consistent when these papers are viewed as a whole. Moreover, they are sometimes made cumbersome by the need to reflect the details of an argument, which are unnecessarily fine for a summary report such as this. Therefore an attempt is made, if only partly successful, to make the terminology and notation used in the following chapters simple and consistent to the extent that it is feasible to do so with reasonable labor, in order that the presentation may be largely self-contained, relatively easy to read, and not unnecessarily burdened by unending lists of definitions.

The following short list of symbols is not comprehensive, but does represent the general intention of the writer. A knowledge of them at the outset will probably make the reading easier.

- n Number of bombs released by an aircraft during one bombing run; in other contexts, the number of sections or cells in a target.
- N Number of bombs released by a formation of aircraft during one bombing run; in other contexts, the total number of bombs considered.
- s Number of attacks per target, by single aircraft or by formations of aircraft.
- s' Number of aircraft dispatched per target.
- σ_a Standard deviation of the aiming-error distribution in one dimension, either range or deflection. In case the standard deviations in range and deflection are unequal, the symbol σ_a is replaced by σ_{ar} and σ_{ad} , indicating the two components in range and deflection, respectively.
- σ_d Standard deviation of the bomb-dispersion distribution in one dimension, either range or deflection. In this presentation the components are immaterial; e.g., the range component in a lengthwise attack on a very long target.
- MRE The mean radial aiming error ($MRE = 1.2533\sigma_a$ for a circular-Gaussian distribution).
- CEP The so-called circular probable error; actually the median radial error ($CEP = 1.1772\sigma_a$ for a circular-Gaussian distribution).
- P_k The probability of at least k hits in a single attack.
- P'_k The probability of exactly k hits in a single attack.

- P_{ks} The probability of at least k hits in s independent attacks.
- P'_{ks} The probability of exactly k hits in s independent attacks.
- E The expected number (or proportion), or long-term average number, of hits.
- I Intended spacing usually of bombs in train, i. e., the spacing which would be obtained in train, if σ_d were zero.

A circumflex ($\hat{\cdot}$) over a symbol connotes the best value of the quantity discussed, from a viewpoint which is clear from the context. Thus \hat{I} may be the value of I which maximizes P_k ; this maximum may be indicated by \hat{P}_k . The circumflex is occasionally used to connote an estimate, e.g., $\hat{\sigma}^2$ as an estimate of σ^2 , which is a departure from the rule unless one is willing to consider best estimates as part of it.

The statistics MRE and CEP are used more often than σ_a by Service personnel, for these can be calculated from operational data by somewhat simpler formulas than that needed for the calculation of σ_a . However, the latter statistic is much more convenient for theoretical studies for much the same reason that MRE and CEP are preferred in practice—its use leads to less cumbersome theoretical formulas. It has certain other advantages, even in the practical field, when it is important to derive from the data as much information as possible (which is usually desirable, of course), but uncritical use of σ_a is more apt to give trouble than use of the simpler statistics. For example, an estimate of CEP obtained by counting is very little affected by contaminated data. This fact probably more than offsets the disadvantage of using an inefficient statistic.

It is of course not important that the quantities used to describe the geometry of a problem—the standard deviations of the aiming errors and of bomb dispersion, σ_a and σ_d , the dimensions of target and bomb fall—be expressed in feet, for only the ratios of these quantities to any one of their number are important. Thus a train-bombing problem involving a 100×600 -ft target, with $\sigma_a = 500$ ft, $\sigma_d = 50$ ft, and $I = 140$ ft, is essentially the same problem as one characterized by $T = 1 \times 6$, $\sigma_a = 5$, $\sigma_d = 0.5$, and $I = 1.4$. For this reason the unit of measurement can be left unspecified, and it is usually desirable to do so (1) because the results then flaunt the little generality to which they are entitled, and (2) because a large number of zeros are eliminated from text and tables. Usually, but not invariably, the target width or the aiming-error statistic is taken as the unit.

Chapter 2

SINGLE-RELEASE BOMBING

2.1 INTRODUCTION

SINGLE-RELEASE bombing has played a very small role in the level-bombing operations of World War II. Generally, the level bombers—light, medium, heavy and very heavy—have been eager, with good reason, to expend their loads on one bombing run, and usually in a formation release.

This inability to use single-release methods, although mildly inefficient, probably has not resulted in a catastrophic loss in hitting power, measured by the average number of hits on the target area, often 2,000 ft or more on a side. The above view is based on two items: (1) an hypothesis that single-release bombardiers' aiming errors would not give on the average a pattern which is much better, if any, than those achieved for patterns by lead bombardiers, who presumably are superior combat personnel, and (2) the fact that once the pattern is reduced to a size comparable to that of the target, the expected number of hits is relatively insensitive to further reductions, and then single-release bombing is simply a limiting case in which the pattern is zero.

In the war, single-release bombing has been almost exclusively the forte of the dive bomber, the fighter bomber, and the torpedo bomber. It is a wry situation which results in the single-release bombing being done exclusively by aircraft and tactics in which the sighting problem is solved crudely or with great difficulty, while the level bombers, with fine visual sights designed exclusively for single-release bombing, do none of it.

The AMP has had little contact with the single-release type of operation during the war and therefore has not analyzed some of the more interesting and difficult situations, such as the attack of maneuvering targets by carrier-based aircraft. Consequently, the studies made of single-release bombing have usually been rather special in character. Items such as guided-missile bombing and air-to-air bombing are the principal ones on the list.

However, despite the restricted application of single-release bombing, the theory of such bombing is often a good first approximation to more complex bombing operations. This theory, although sometimes a little onerous computationally, is so much simpler than that required for a good treatment of

the complex operation that it is profitable to use it for preliminary exploration and for the development of useful mnemonics. Therefore, additional space is devoted to it here.

2.2 FORMULAS AND APPROXIMATIONS

The probability of hitting a target of area T with a single bomb when the aiming errors in range and deflection are independently and normally distributed is

$$P = \frac{1}{2\pi\sigma_{ar}\sigma_{ad}} \int_T \int e^{-\frac{1}{2}(x^2/\sigma_{ar}^2 + y^2/\sigma_{ad}^2)} dx dy \quad (1)$$

where σ_{ar} and σ_{ad} are the standard deviations of the aiming error distribution in range and in deflection, respectively. The integration is conducted over the area of the target.

It is often difficult to use equation (1) because, in general, it requires numerical integration. The four exceptional target areas for which the necessary functions have been tabled are:

1. *Rectangular targets.* P may be computed using well-known single- and bi-variate normal probability tables.^{1,2}

2. *Right-triangle targets,* with the aiming point at an acute vertex. P has been tabulated by AMP.^{1,2}

3. *Circular targets.* P has been tabulated by AMP³ for the case $\sigma_{ar} = \sigma_{ad}$. When the center is the aiming point, the integration can be performed explicitly.

4. *Elliptical targets,* with the aiming point at the center and $\sigma_{ar} = \sigma_{ad}$. P is expressible in terms of the P for circular targets, which is tabled, as mentioned above.¹

These are the principal cases in which numerical integration may be avoided. It would obviously be desirable to have at hand a rapid method for computing P for regions of any shape and with the aiming point anywhere. A numerical method, usable when $\sigma_{ar} = \sigma_{ad} = \sigma_a$, is to evaluate

$$P = \frac{1}{2\pi} \int_c (1 - e^{-\frac{1}{2}[r(\theta)/\sigma_a]^2}) d\theta \quad (2)$$



integrating round the contour c , say $\phi(r, \theta) = 0$, of the target. This process is expedited by use of an inverse table of the integrand which has been prepared by AMP.²

In single-release bombing the quantities σ_{ar} and σ_{ad} include the components of variance associated with bomb-dispersion σ_a^2 , which must be explicitly accounted for in more complex operations, such as in train bombing.

There are several uses for equation (1). As stated, it is an exact expression (the assumptions being granted) for the probability of hitting with one bomb. The quantity sP is an exact expression for the expected number, E , of hits in a series of s single releases. The quantity nP is exact for the expected number E of hits in a scatter bombing attack, provided one uses standard deviations, say σ'_{ar} and σ'_{ad} , defined by

$$\begin{aligned} \sigma_{ar}^2 &= \sigma_{ar}^2 + \sigma_d^2 \\ \sigma_{ad}^2 &= \sigma_{ad}^2 + \sigma_d^2, \end{aligned} \tag{3}$$

in which the aiming-error and bomb-dispersion standard deviations are suitably combined. It is an approximate expression for the expected number, E/n or E/N , of hits per bomb in train and pattern bombing, useful when the dimensions of train or pattern are small compared to the aiming-error parameter, σ_a . In fact, it is exact for pattern bombing when the bombs in pattern are normally distributed.

2.3 APPROXIMATIONS TO P

There are useful approximations to equation (1). When the greatest dimension of the target is small compared to σ_{ar} and σ_{ad} , equation (1) yields

$$P = \frac{T}{2\pi\sigma_{ar}\sigma_{ad}}, \tag{4}$$

where T is the area of the target.

If $\sigma_a = \sigma_{ar} = \sigma_{ad}$, and if one makes use of the relationship between σ_a and the mean radial error, MRE , in a circular-Gaussian distribution, namely

$$MRE = \sqrt{\frac{\pi}{2}} \sigma_a, \tag{5}$$

equation (4) may be written

$$P = \frac{T}{4(MRE)^2} = \frac{T'}{4}; \tag{6}$$

i.e., for small targets the probability of hitting is approximately one-fourth the area of the target, provided the target dimensions are expressed in terms of

the mean radial error as unit. For example, the probability of hitting the target shown in Figure 1 is approximately $P = 3/(4 \times 8 \times 8) = 0.0117$, which

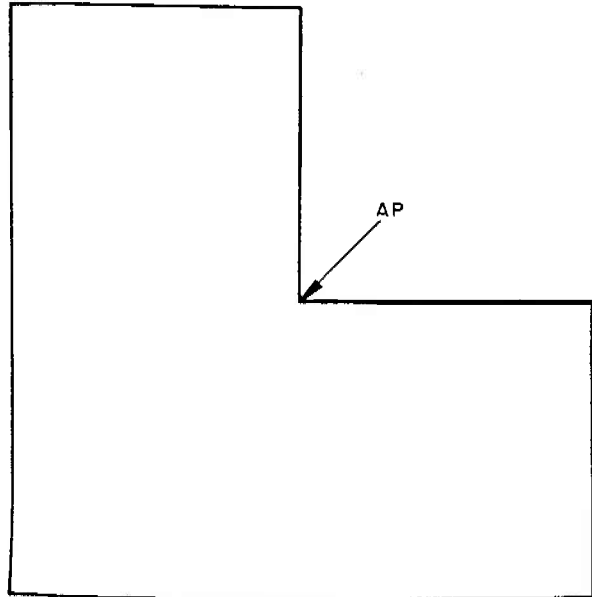

FIGURE 1. Illustrative target.

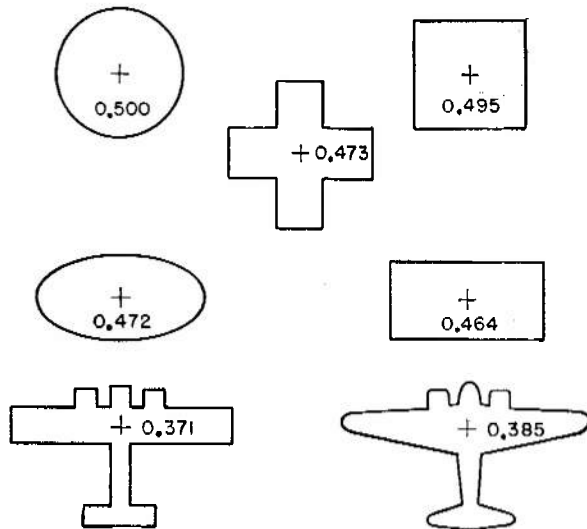

FIGURE 2. Illustration of the dependence of probability of hitting on shape of target. All of the above targets have the same area, namely the area enclosed by the CEP circle.

compares favorably with 0.0116 obtained by equation (1), when the sides at top and right are of unit length and when $MRE = 8$, and where the aiming point AP is at the corner indicated.

Of course, a formula which takes no account of target shape must be used only for small targets, for when the probabilities are substantial, they do de-

pend sensibly on the target's shape. This is apparent in the targets of Figure 2, which all have the same area.

The judgment of when equation (6) may be used with safety is assisted by reference to another approximate expression which may be used for rectangular targets ($T = L \times W$) of any size, namely

$$P = \left[(1 - e^{-\frac{L^2}{4}}) (1 - e^{-\frac{W^2}{4}}) \right]^2 \quad (7)$$

This expression is never wrong by more than one or two per cent if the aiming point is at the center. When equation (7) yields values closely approximating those obtained from equation (6), there is then no question regarding the applicability of equation (6).

As an example of the accuracy of equations (6) and (7), consider a 0.2×2 target and $MRF = 5$. Here $P = 0.003959$ and equations (6) and (7) err, in excess, by 4×10^{-5} and 10^{-6} , respectively.

It is generally appreciated, and evident from the equations, that the probability depends sensitively on the aiming-error parameter, σ_a , varying inversely with the square of σ_a when the target is small. It is interesting to see exactly how this dependence varies with the target dimensions. A particular way of displaying the effect is to answer the question: What is

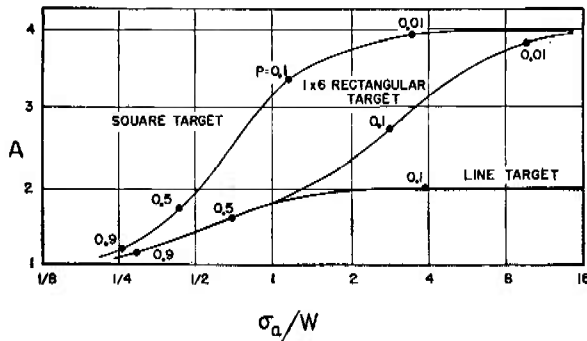

FIGURE 3. The advantage factor A vs σ_a/W . A refers to the case when the standard deviation of the aiming errors is reduced from σ_a to $\sigma_a/2$. The probabilities written along the curves are based on the value σ_a . W is the target width.

the advantage factor, A (i.e., ratio of new to old probability), when the aiming error is halved?

Figure 3 shows a plot of A versus σ_a/W (this is the original or unhalved value of σ_a), for 1×1 , 1×6 , and $1 \times \infty$ targets. The values along the curves are the original probabilities. It is clear that the four-fold advantage does not accrue unless σ_a is quite large compared to target dimensions. Indeed, in the

most favorable case, that of the square target, the advantage does not approach this value until $\sigma_a = 4$, for the 1×6 target σ_a must be greater than 8. For the $1 \times \infty$ target the maximum value of A is, of course, 2.

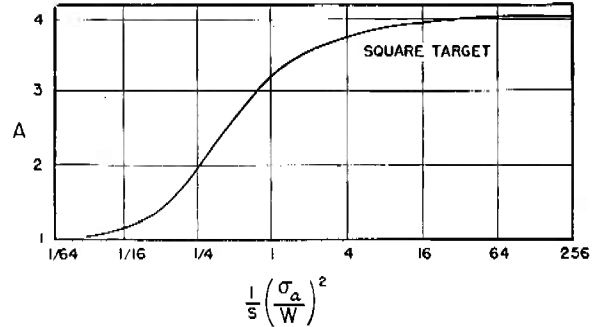

FIGURE 4. The advantage factor A vs $(1/s)(\sigma_a/W)^2$. A refers to the case when the standard deviation of the aiming errors is reduced from σ_a to $\sigma_a/2$. W is target width, and s is the number of independent attacks. Strictly, this plot should be a scatter chart, but on this scale the computed points are usually indistinguishable from the curve.

Figure 4 shows the advantage factor, when the value of σ_a is halved, for a square target subjected to independent attacks; the probability of at least one hit,

$$P_1 = 1 - (1 - P)^s \quad (8)$$

is the criterion. The plot is of A versus $(1/s)(\sigma_a/W)^2$. Strictly, this relationship yields a scatter chart, but the calculated points (for $s = 1, 10, 100$) are so close to a simple curve that only the empirical locus is shown in the figure.

2.4 GRAPHICAL ESTIMATION OF P

The need for a rapid method of estimating P in equation (1), for targets of any shape and for any choice of aiming point, was remarked upon earlier in this chapter. This need is met, in large part, by a graph paper designed by AMP, which is shown in Figure 5. This is a cell-diagram representation of the circular-Gaussian distribution. Each cell marks off a region in which the probability is 0.001, except for certain of the outer rings where the cells correspond to probabilities of 0.00025 and 0.0001, as indicated. The dots are at the cell medians.

To use the cell diagram, one first expresses the target's dimensions in units of σ_a and then draws the target on the diagram (or on a transparent overlay) in such a manner that the aiming point falls at

2.5 APPLICATION OF THE SLIDE RULE FOR SMALL-TARGET BOMBING PROBABILITIES

A slide rule, titled *Small-Target Bombing Probabilities*, is available for calculation of the expected number E of hits and the probabilities P_k of at least k hits ($k = 1, 2, 3, 4$) for attacks on small targets.

The important assumption made in designing the slide rule is: That in a region around the origin, of radius about half that of the circular probable error CEP circle, the distribution is statistically uniform, the density being equal to the central density of a

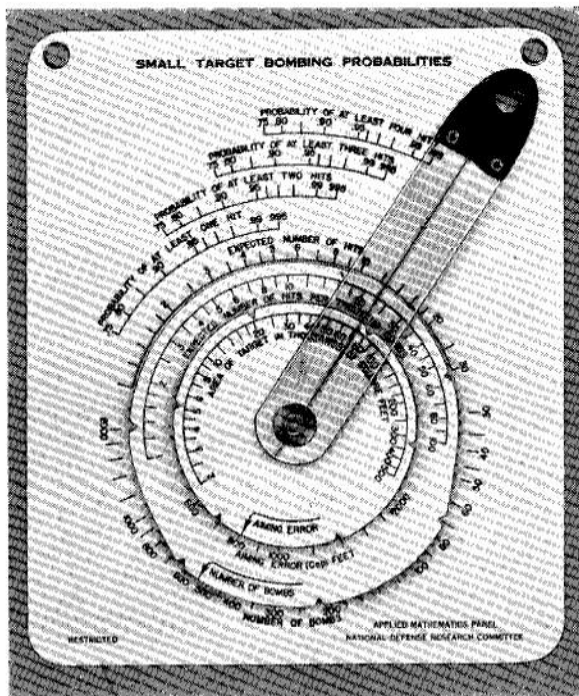

FIGURE 6. The AMP *Small-Target Bombing Probabilities Calculator*.

circular-Gaussian distribution. The answers of the slide rule are correct for a small centrally located target when the aiming-error statistic, CEP , is estimated on the assumption that the distribution is strictly Gaussian.

The slide rule, in effect, computes the probability that (1) a bomb will fall in this central region, and (2) it will hit a target in that region. The rule is shown in Figure 6.

The slide rule for small-target bombing probabilities has been manufactured in small quantities and distributed to some operations analysts and other personnel in the Services.

2.6 ESTIMATION OF CEP FROM STANDARD DEVIATIONS

The relationship between CEP and σ_a ,

$$CEP = \sigma_a \sqrt{2 \log_e 2} = 1.1772 \sigma_a, \quad (9)$$

is widely used to calculate the radius, $R = CEP$, of the 50 per cent circle in a circular-Gaussian distribution. Certain Army manuals advocate a formula equivalent to

$$CEP = \sqrt{2 \sigma_{ar} \sigma_{ad} \log_e 2} \quad (10)$$

for use when the standard deviations in range and deflection are not equal. The question arises: How may one approximate the radius R of any percentage circle, say p , and can something better than equation (10) be offered for the radius of the $p = 0.5$ circle?

The three formulas,

$$\begin{aligned} R_1 &= \sqrt{2 \sigma_{ar} \sigma_{ad} \log_e 1/(1-p)}, \\ R_2 &= (\sigma_{ar} + \sigma_{ad}) \sqrt{\frac{1}{2} \log_e 1/(1-p)}, \\ R_3 &= \sqrt{(\sigma_{ar}^2 + \sigma_{ad}^2) \log_e 1/(1-p)}, \end{aligned} \quad (11)$$

have been compared for $0.1 \leq p \leq 0.9$ and $0.5 \leq \sigma_{ar}/\sigma_{ad} \leq 1$. The result is that R_1 gives the closest approximation when $0.1 \leq p \leq 0.3$, R_2 when $0.4 \leq p \leq 0.75$, and R_3 when $0.8 \leq p \leq 0.9$. R_2 is the best overall approximation. Hence, for the radius of the 50 per cent circle the formula

$$CEP = (\sigma_{ar} + \sigma_{ad}) \sqrt{\frac{1}{2} \log_e 2} = 0.5887(\sigma_{ar} + \sigma_{ad}) \quad (12)$$

is recommended; it is more accurate than equation (10) and simpler to compute.

The tables of functions and other items cited in the text are contained in several documents prepared by AMP.^{1, 2, 3, 4}

2.7 SELECTION OF AIMING POINTS FOR IMPROVEMENT OF TARGET COVERAGE

When the target is large relative to the aiming errors, it may be desirable to use more than one aiming point. The study discussed here⁵ is concerned with this question. Since the mathematics used is preeminently that of single-release theory, it is included in this chapter; however, extension of the theory to certain classes of pattern bombing is justified.

Purposes of the Study. The purposes of the study are (1) to develop methods for estimating the number and position of aiming points which will maximize

the expected coverage of the target by the lethal areas associated with the bombs, and (2) to estimate the number of bombs required to achieve a specified expected value of the coverage in optimum attacks, in the above sense.

Method of Analysis. In brief, the method of analysis is to solve accurately an idealized problem in one dimension, i.e., the case in which bombs fall exactly on a line segment, and then to apply the criteria so discovered to each of two mutually perpendicular cross sections of an area target. This device avoids the intrinsic mathematical complexities of the two-dimensional case and, while the results therefore cannot be strictly accurate for that case, there is every reason to believe that they are excellent for practical purposes.

This belief is due in part to the fact that the results in the one-dimensional case suggest that substantial departures from the best spacing of aiming points I do not seriously affect the expected fraction F of the target covered. This is illustrated in Figure 7 for the case of two aiming points and a line target of length 6 ($\sigma_a = 1$). The family parameter is C , called the potential coverage, which is the number of times the target area T is contained in the sum of the lethal areas for all the bombs, i.e., $C = sa/T$, where $a =$ lethal area for a single bomb and $s =$ number of bombs.

Results. The results of the study give the optimum number n of aiming points for line targets of various

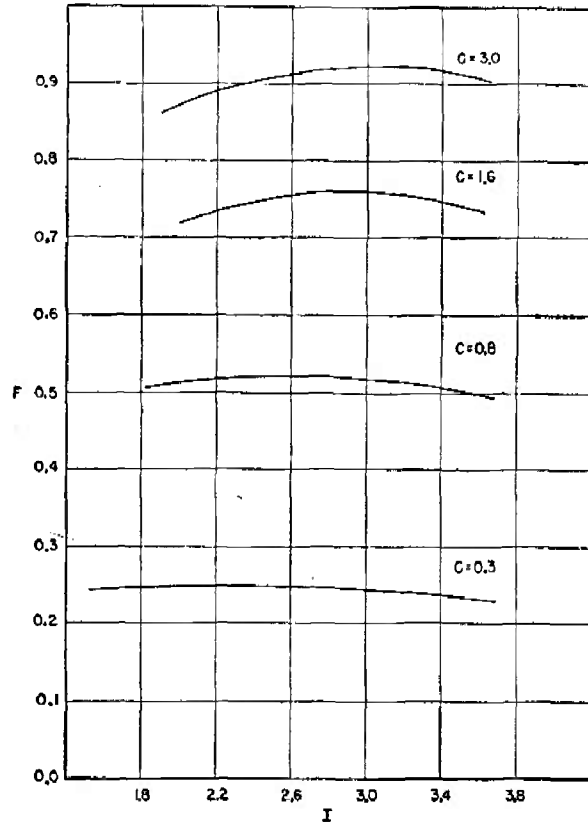

FIGURE 7. Illustrating the relatively weak dependence of proportion F of target covered on the spacing I between aiming points. In this case there are two aiming points and the target is six units long. $C = sa/T$, the potential coverage, where $s =$ number of bombs, $a =$ effective area of each bomb, $T =$ area of target.

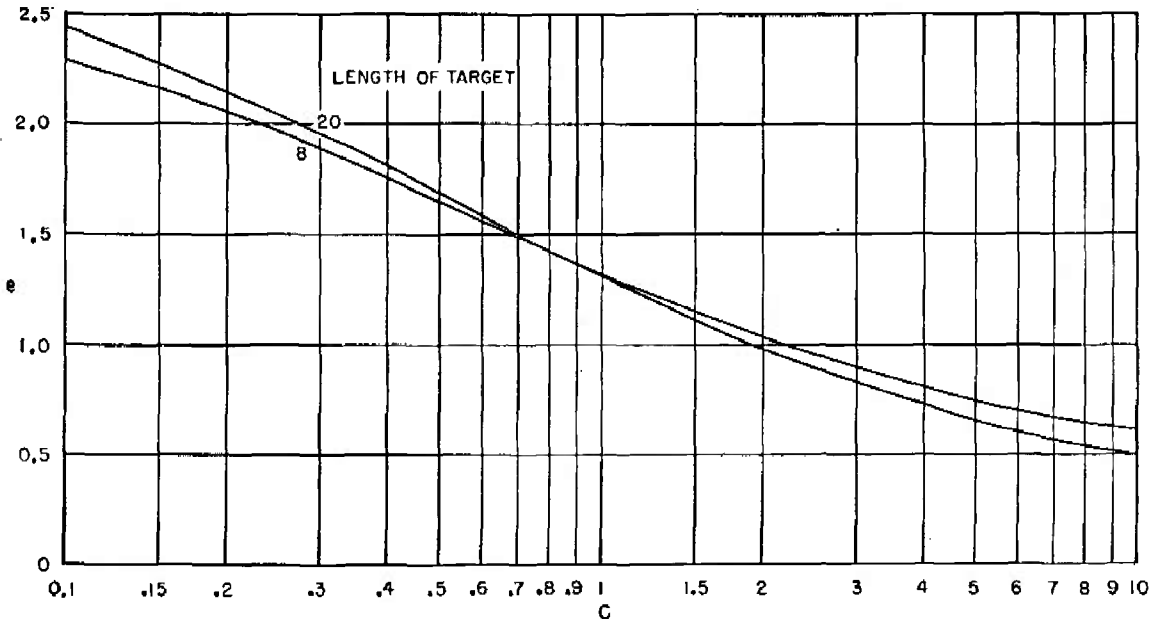

FIGURE 8. Best distance e from ends of target to aiming points (intermediate points spaced at $I = 2$) vs potential coverage $C = sa/T$. $s =$ number of bombs, $a =$ effective area of bombs, $T =$ area of target.

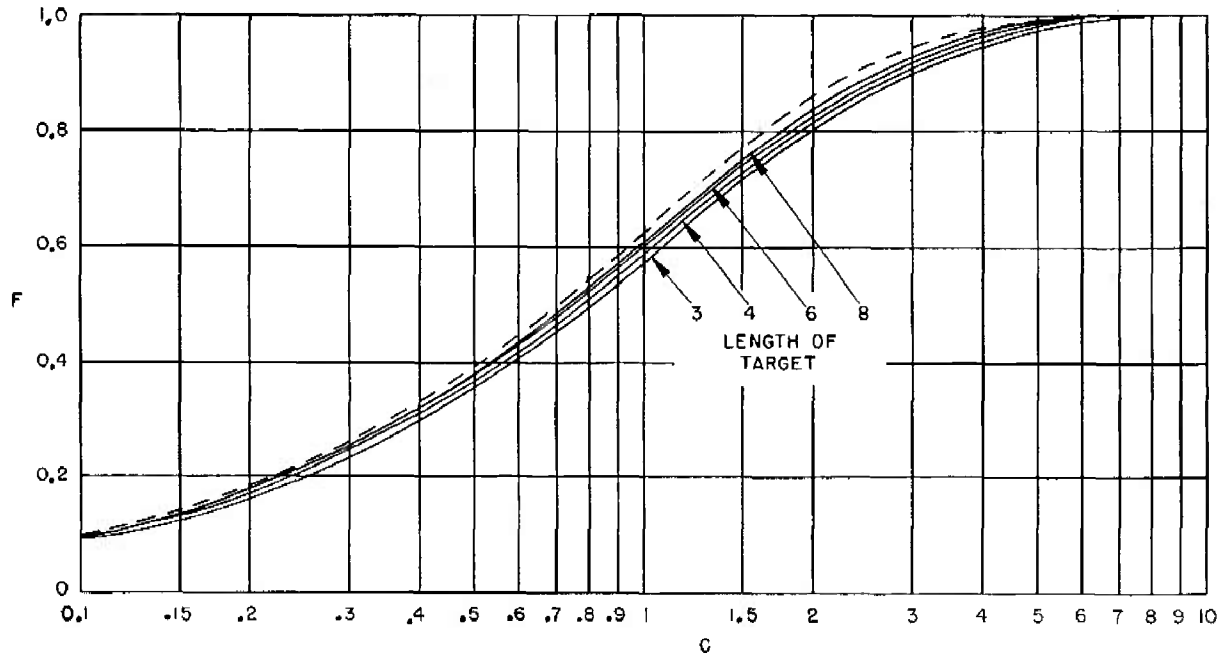

FIGURE 9. Expected proportion F of target covered, when optimum number of aiming points are used, potential coverage $C = sa/T$. s = number of bombs, a = effective area of bombs, T = area of target.

lengths, T , according to the following scheme, in which $\sigma_a = 1$ is the unit;

$$\begin{aligned} T \leq 6 & \quad n = 2 \\ 6 \leq T \leq 8 & \quad n = 3 \\ 8 < T & \quad n = 1 - e + T/2. \end{aligned}$$

The last expression is rounded to the nearest integer. The symbol e connotes the distance from an end of the target to the nearest aiming point; this is determined with sufficient accuracy by Figure 8.

As a simple rule-of-thumb, the spacing $I = 2$ is recommended.

The expected fraction F of target covered is shown in Figure 9 as a function of the potential coverage C , and hence as a function of the number of bombs s .

A detailed discussion of the theory and several worked examples, showing how to apply it to line and area targets, are given in an AMP paper.⁵

2.8 SELECTION OF AIMING POINTS FOR IMITATION OF COMBAT ERRORS

The following study⁶ is of interest in connection with proving-ground tests of guided missiles. It is a detail in the design of a test program for the missile RAZON.

Purpose of the Study. The purpose is to select a single-offset aiming point which will have this prop-

erty: The radial distribution of errors measured from target center, which results from having a proving-ground bombardier aim at the offset, should be the best approximation to the radial distribution which is obtained in combat. The weapon under test will thus be subjected to aiming errors whose magnitude and frequency are comparable to those which occur in the field.

Method of Analysis. The method of analysis is quite straightforward. The distribution of the radial errors, r , in combat is assumed to be circular Gaussian; the density is

$$\rho(r) = \frac{r}{\sigma_a^2} e^{-r^2/2\sigma_a^2}. \quad (13)$$

The proving-ground standard deviation, say σ'_a , together with an offset aiming point at the distance R , gives rise to the following probability density:

$$\frac{\rho'(r)}{R} = \frac{r}{2\pi\sigma_a'^2} \int_0^{2\pi} e^{-1/2\sigma_a'^2 [r^2 + R^2 - 2Rr \cos \theta]} d\theta. \quad (14)$$

ρ and ρ' are calculated and plotted for various values of r , for a trial value of R . The calculations are repeated using new values of R until, by trial, a satisfactory R is discovered. The process can be refined by adapting a mathematical criterion to describe the goodness of fit of ρ' to ρ .

Results. The preceding calculations lead to graphs of the form shown in Figure 10. Graph A shows

the usual distribution of radial errors in combat and in practice; graph B compares the distribution of radial errors in combat with those in practice with an offset. Although the fit in graph B is far from

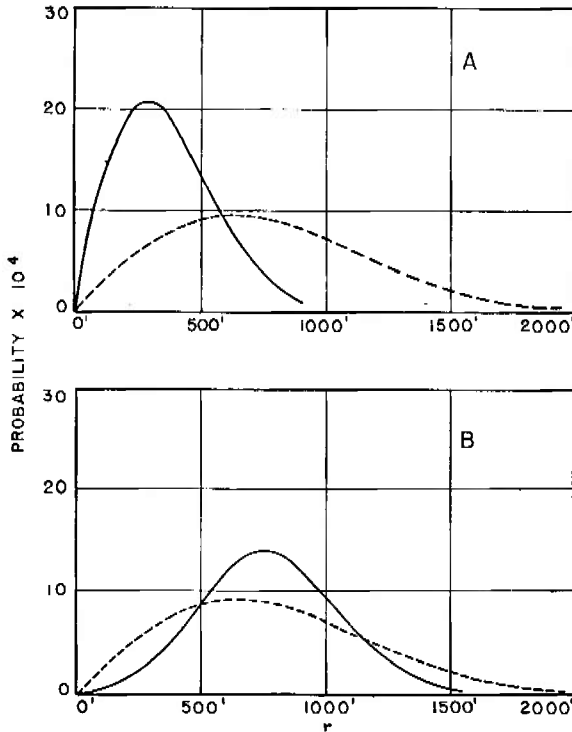

FIGURE 10. A. Distribution of radial aiming errors in practice (solid) and combat (broken) bombing, at altitude of 20,000 ft. B. Same, except that practice aiming point is offset 700 ft. The practice and combat mean radial errors, *MRE*, are assumed to be 370 ft and 800 ft, respectively.

excellent, it represents a worthwhile improvement over that in graph A.

In tests where the complexity can be tolerated, the use of two or more offset aiming points would facilitate a closer fit.

Further details and results are given in an AMP report.⁶

2.9 LATERALLY CONTROLLED MISSILES

The following discussion relates to work, sometimes of a very elementary nature, done during the development period of the laterally controlled missile AZON.

Purpose of the Study. The purpose of the study is to forecast the probable value of AZON compared to that of standard bombs in single-release attacks on non-maneuvering and maneuvering targets.

Method of Analysis. For non-maneuvering targets it is a simple matter to compute the probabilities for AZON and standard bombs, under various hypotheses regarding the aiming-error distributions.

The maneuvering target is a different matter. Since the study is intended to be exploratory rather than definitive, a very simple mathematical model is used (see Figure 11). The target is assumed to have three alternatives at an instant late in the bombing run, namely, it may remain on course, or initiate a hard turn to right or left. The probability of a turn is P_T . The bombardier may suspect, but cannot know, that the target will turn. If he gambles that it will, he aims short, at the point marked C; the probability that he aims short is P_B . Calculations are made covering all values of P_T and P_B in the ranges $0.25 \leq P_T \leq 0.75$ and $0 \leq P_B \leq 1$. The scale of the target and its maneuvers are intended to simulate a fast destroyer under attack from an altitude of about 15,000 feet.

Results. The principal results are shown in Figure 12, where the probability of hitting, P , is plotted,

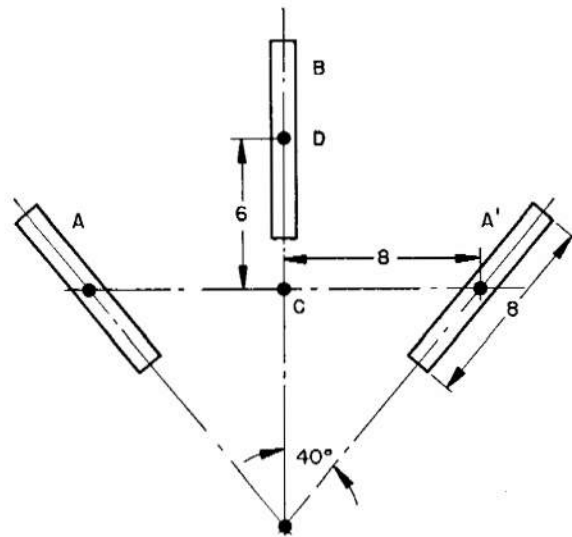

FIGURE 11. Model for maneuvering ship attacked when on course CD. If ship continues on course or if it turns to left (or right), it will arrive at B or at A (or A') when bombs strike. Bombardier aims at C if he forecasts a turn, otherwise at D. All distances in terms of target width.

not against W/σ_a , but against W/σ'_a , where $\sigma'_a = \sigma_a^2 + (W/2)^2$. For standard bombs the standard deviation of the aiming-error distribution in range and deflection is σ_a ; for AZON the range standard deviation is $\sigma_{ar} = \sigma_a$ and the deflection standard deviation is $\sigma_{ad} = W$.

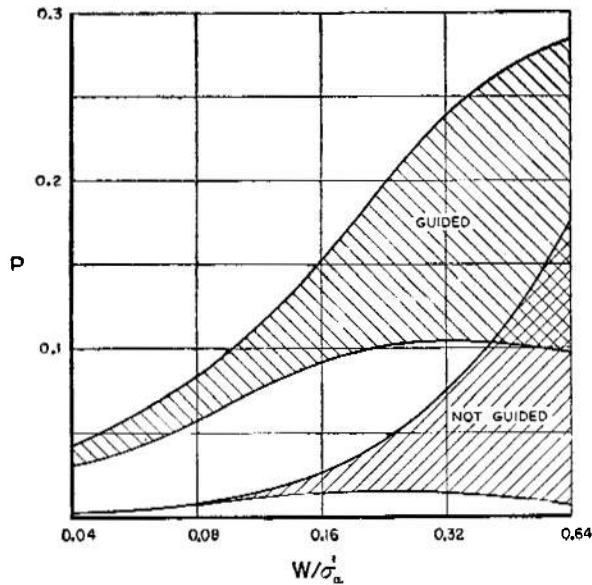

FIGURE 12. Probability P of hitting maneuvering target with guided (AZON) and standard bombs vs W/σ'_a ; W = target width, $\sigma'_a = \sqrt{\sigma_a^2 - (W/2)^2}$, where σ_a is the standard deviation of the aiming-error distributions in range and, for standard bombs, in deflection as well. The ranges of values indicated by the cross-hatching for a fixed value of W/σ_a correspond to various choices of the probabilities that the ship will turn and that the bombardier thinks it will turn.

That there are probability belts, rather than single curves in the figure, is due to the fact that probabilities P_i are calculated for ranges of values of P_T and P_B . The upper boundary of a belt corresponds to the most favorable pairs of values of P_T and P_B from the viewpoint of the bombardier, i.e., the probability is high that the bombardier will successfully anticipate the ship's maneuver. The lower boundary corresponds to the least favorable pairs.

2.10

AIR-TO-AIR BOMBING

The results presented in this section refer to a preliminary evaluation of the potentialities of air-to-air bombing.

Purpose of the Study. The purpose of the study^{7,8} is to estimate the probability of hitting a medium bomber (*Japanese Betty*: Mitsubishi Type 01), two tactics and three fuzings being considered. The tactics are (1) high attack (1,000–3,000 ft) from the rear and (2) low frontal attack (300–500 ft). The fuzings are (1) percussion fuze, (2) time-plus-percussion combination, and (3) proximity fuze.

Method of Analysis. The analysis is made in terms of the two tactics.

1. *High attack from rear.* For percussion fuze, the target is a plane contour similar to a plan-view of the aircraft. For time-plus-percussion fuze, the target is

assumed to comprise a vertical right-cylinder such that the walls and bases are at a distance r from the above-mentioned contour, but there is no target directly beneath the contour. For proximity fuze, the target is that horizontal cross section of the cylinder which contains the contour.

2. *Low level frontal attack.* For percussion fuze, the target is a plane contour similar to a frontal view of the aircraft. For time-plus-percussion fuze, it is a horizontal right-cylinder such that the walls and bases are at a distance r from the contour, and the cylinder is hollow immediately to the rear of the contour. For proximity fuze, the target is that vertical cross section of the cylinder which contains the contour.

For the high rear attack the aiming errors in range and deflection are measured by σ_a ; vertically, in the case of the time fuze, by σ_v . For the frontal attack the bomb trajectory is almost horizontal, so aiming errors are measured vertically and horizontally (and again characterized by σ_a); in the time-fuze case there is an error along the line of sight (strictly, along the trajectory) measured by, say, σ_h , which reflects fuzing and ranging difficulties.

The models used for targets and aiming-error distributions are the important items in this analysis; the rest is arithmetic.

Results. The results of the study are presented in a series of tables similar to Tables 1 and 2. If it is desired to compare the tactics, it is suggested that nearly equal values for σ_v and σ_h be chosen, but that values of σ_a , such as 200–400 ft, for the high attack will be most realistically compared with a value of σ_a of 25–100 ft for the low attack. The latter values imply very good instrumentation, of course, such as the angular-rate bombsights may afford.

Further details and results are contained in two working papers by one of the AMP research groups.^{7,8}

TABLE 1. Probability of hitting a medium bomber in a high level rear attack using contact fuze, or using proximity fuze which detonates at a distance r .

σ_a	Contact		Proximity	
	$r = 0$	$r = 25$	$r = 50$	$r = 100$
50	0.072	0.454	0.735	0.972
100	0.021	0.142	0.280	0.581
200	0.0045	0.038	0.080	0.198
400	0.0011	0.0096	0.020	0.055

TABLE 2. Probability of hitting a medium bomber in a low level frontal attack using contact fuze, or using proximity fuze which detonates at a distance r .

σ_a	Contact		Proximity	
	$r = 0$	$r = 25$	$r = 50$	$r = 100$
25	0.057	0.71	0.96	1.00
50	0.015	0.31	0.62	0.94
100	0.0037	0.096	0.23	0.52

Chapter 3

TRAIN BOMBING

3.1

INTRODUCTION

ALTHOUGH THE United States entered World War II with first-class single-release bombing equipment, such as the high-altitude synchronous bombsights designed by Norden (M-14) and Sperry (S-1), the thought given to the problem of train bombing had resulted only in the development of certain auxiliary equipment, notably the mechanical and electrical intervalometers of the A and B series, which had been installed in bombardment aircraft. In a strict sense, the resulting combination of bombsight and intervalometer constituted a makeshift solution to the train-bombing problem, for only the first bomb released, of those released in a train, could be aimed with the precision normally associated with the synchronous sight. Equipment explicitly designed for the train-bombing task would have aimed the center of the train with single-bomb precision. Actually, it is possible to aim the center of the train with this equipment, but only by falsifying the input data fed to the bombsight. Unfortunately, the bombsight is not completely fooled by this artifice and consequently the equipment does not, even under proving-ground conditions, aim trains as precisely as it aims individual bombs.

Thus our equipment and, incidentally, our training program for bombardiers emphasized the single-release bombing problem. On the other hand, it appeared, from the daily practices of the British and Germans, that in current warfare against a first-class opponent one could not afford to make more than one bombing run per sortie and hence that the problem of train bombing would be very much to the fore. Subsequent experience indicated that this viewpoint represented a step in the right direction, but a much too modest one, for by the time our daylight bombers appeared over Europe the opposition was so strong as to preclude anything except formation bombing.

Before combat experience showed that single-release bombing was not going to be the principal technique of bombing in the war, the Services and the National Defense Research Committee [NDRC] initiated work on the various theoretical aspects of the train-bombing problem. As a result, a considerable body of information on the subject is now in existence.

As early as 1932, the British had set up the fundamental equations which govern the probabilities in train bombing, but had abandoned these in favor of approximate formulas which were much more tractable, computationally. As a matter of fact, for aiming errors of the magnitude produced in British combat bombing operations, where area bombing was quite frankly the goal, the approximations used were entirely adequate. But for the level of accuracy achieved in practice operations with our single-release equipment, even when it was misused to lay trains, it appeared that the more precise mathematical formulation would be needed. Accordingly, the work of AMP was based on the computationally difficult formulas.

The theory of single-release bombing is usually quite simple; predictions can be based on a single distribution function, or probability-density function, and this is often of simple form. Train bombing, however, requires for its description the use of two distribution functions. The complexities of the problem are in large part due to the fact that these two distributions preserve their individuality to the end; not until the number of bombs in train is reduced to one do the functions combine nicely. These distribution functions are defined below.

Consider n equally spaced points lying on a line. These points mark the intended relative positions of the bombs in the train. The centroid of these points, the point midway between the first and last, is defined as the *train center*.

The position of the train center relative to the target, and the position of a bomb of the train at impact, relative to the point which marks its intended position in the train, are random variables (with two components). The distribution functions which measure the probability density of the variables at all points in the plane are called the aiming-error distribution and the dispersion-error distribution. They are usually postulated to be two-dimensional Gaussian distributions. Thus the aiming-error distribution has to do with the position of the train considered as a single unit, whereas the dispersion-error distribution has to do with the behavior of the bombs within the train, regardless of where the train has fallen.

3.2
**PROBABILITIES OF HITTING
 RECTANGULAR TARGETS WITH
 SINGLE ATTACKS**

The fundamental study of train-bombing probabilities was initiated by the Ballistic Research Laboratory [BRL] of the Aberdeen Proving Ground. BRL had computed train-bombing probabilities for the one-dimensional case, i.e., for very long targets, and requested that AMP extend the inquiry to the two-dimensional case.

This proved to be the most arduous computing task undertaken by AMP during the war, due to the large number of parameters involved and to the tediousness of the individual calculations. The calculations were done, in part, by hand machines, but the greater part was done on IBM punched-card equipment.

The fundamental formulas, and consequently the probability results, have application to fields other than train bombing; e.g., torpedo spreads, naval gunnery, aerial gunnery.

Purpose of the Study. The purpose of the study is to calculate probabilities of hitting with a train of bombs under various hypotheses concerning the aiming-error and dispersion-error distributions, the size of the target, the angle at which it is attacked, the number of bombs in train, and the spacing of bombs in train. The ultimate goal is to ascertain the importance of these factors and to discover the optimum values of the controllable inputs, particularly the optimum spacing in train, say I .

That there is such a thing as optimum spacing, in general not zero, may be appreciated from qualitative considerations. Suppose that the design is to try to achieve at least one hit on a long narrow target by attacking across it, which is usually the best course. If the bomb spacing is very small the train will be short in length and it is likely that, because of the aiming error of train center, none of the bombs will strike close to the target. Now suppose that the spacing between adjacent bombs is large: The train will be long and there is a much better chance now that the target will lie within the train; but the large spacing makes it likely that the target, while bracketed, will not be hit. Intuition suggests that there is some particular value of the spacing, say \hat{I} , which offers the best compromise, and this is indeed the case.

The problem of finding the value of the best spacing is too difficult to be solved by intuitive argu-

ments; in fact it is difficult to guess, usually, whether the best spacing is less than or greater than the target width.

Method of Analysis. A more rigorous method of analysis was followed. The probability P_k of hitting a rectangular target T at least k times in a single attack with a train of n bombs, may be written as

$$P_k = \int_{-\infty}^{\infty} \int_{-\infty}^{\infty} \rho_a G_k dX dY, \quad (1)$$

where

$$G_k = \sum_{j=k}^n (-1)^{j-k} \binom{j-1}{k-1} \sum_{i_1, \dots, i_j} p_{i_1} \dots p_{i_j}, \quad (2)$$

and

$$p_i = \iint_T \rho_d dx dy, \quad (3)$$

(X, Y) and (x_i, y_i) being coordinate systems, each oriented in the directions of range and deflection, with their origins at target center and train center, respectively.

Here G_k and p_i are the conditional probabilities for obtaining at least k hits with the train, and for hitting with the i th bomb of the train, respectively, given that the aiming error is (X, Y) . The right-hand summation in equation (2) is the overall combinations of the n values of p , taken j at a time.

Also, ρ_a and ρ_d are the aiming-error and dispersion-error densities, both assumed to be two-dimensional Gaussian functions. In almost all of the calculations it is assumed that these are circular distributions, i.e.,

$$\rho_a = \frac{1}{2\pi\sigma_a^2} e^{(-1/2\sigma_a^2)(X^2 + Y^2)} \quad (4)$$

and

$$\rho_d = \frac{1}{2\pi\sigma_d^2} e^{(-1/2\sigma_d^2)(x_i^2 + y_i^2)}. \quad (5)$$

The angle of attack θ measured from the long axis of the target, and the spacing I between bombs in train are contained implicitly in the limits of integration, T .

The form of P_k exhibited in equations (1) to (3) is not the one used for calculation. At the expense of some algebra it may be thrown into various less concise forms which, however, are much more useful in practice. The question as to the best form for calculation is a difficult one which requires and merits much time when an extensive computing program is undertaken.

Results. The results of the study are presented both in tables and graphs of which Table 1 and Fig-

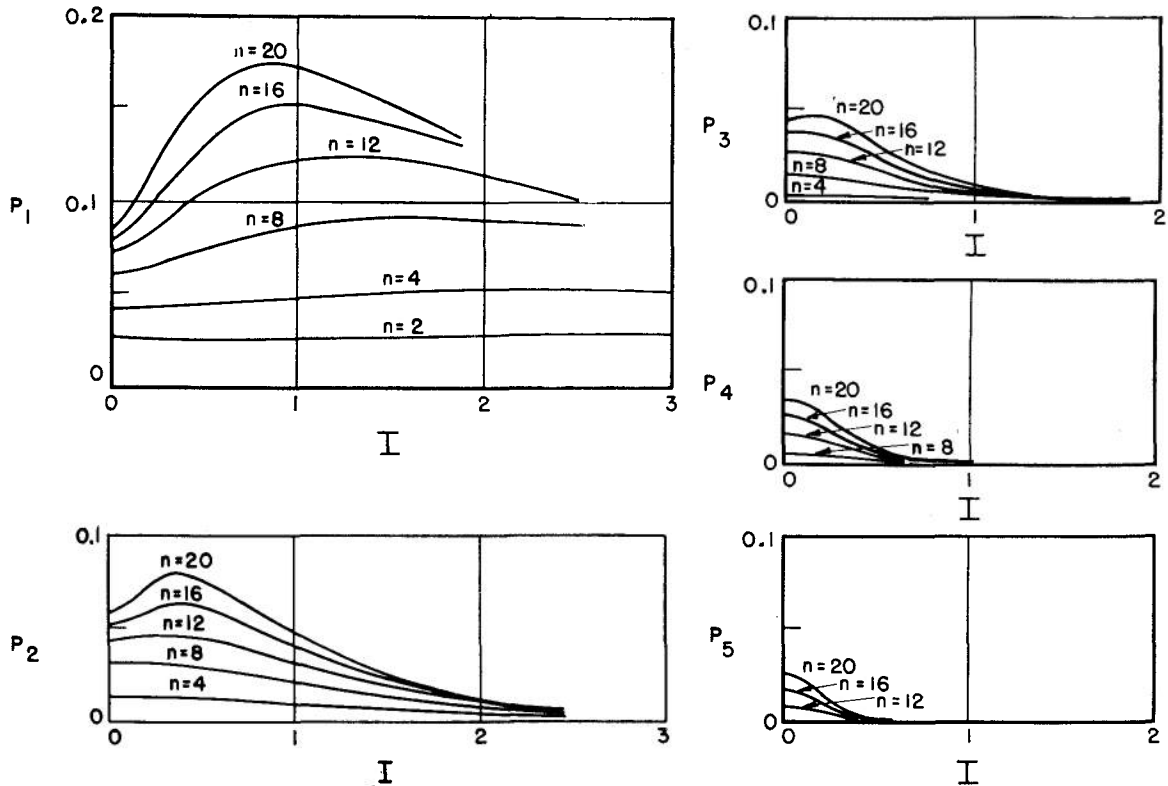

FIGURE 1. Probability P_k of at least k hits vs spacing I of bombs in train. Target 1×6 , $\theta = 90^\circ$, $\sigma_a = 8$, $\sigma_d = 1$. I is expressed in target width units.

ure 1 are typical examples. Here, for fixed values of the target dimensions, the angle of attack, the multiplicity of hits, the number of bombs in train, the aiming-error and dispersion-error distributions, are given the probabilities of success as a function of the spacing I in train; I is expressed in terms of target width as unit.

Tables and graphs have been prepared for the sets of conditions enumerated in Table 2 and may be found in AMP documents.¹⁻⁷

As anticipated, a characteristic of all this material is that there is always an optimum spacing \hat{I} , such that $P_k(\hat{I})$ is a maximum, say \hat{P}_k . Usually the curve is quite flat in the neighborhood of the maximum, so that small changes in the spacing have little effect on the probability. However, the maxima tend to become more peaked when the number n of bombs in train is increased, and when the aiming-error distribution becomes more compact, i.e., when the σ_a is decreased.

The maximum probability may occur for any value of the spacing, greater or less than target width, and including 0. Whether or not the value $I = 0$ corresponds to the maximum, the curve al-

ways has a turning point there, i.e., the tangent is horizontal when $I = 0$. This qualitative feature was not known when most of the curves, which often depend on relatively few ordinates, were drawn. Therefore, values read from curves showing high contact with the P_k axis should be discounted in that neigh-

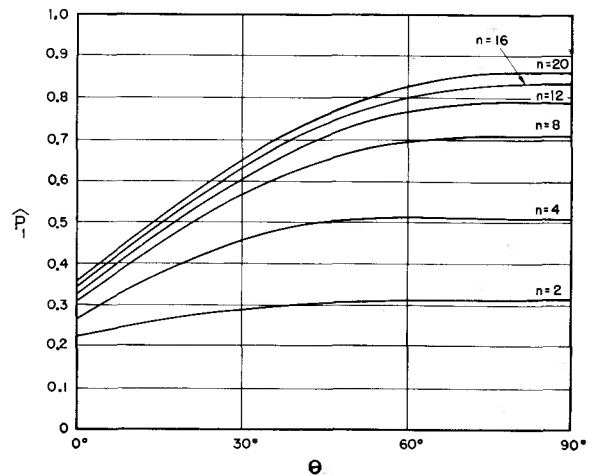

FIGURE 2. Maximum probability \hat{P}_1 of at least one hit vs angle of attack θ , for various values of n , the number of bombs in train. Target 1×6 , $\sigma_a = 2$, $\sigma_d = 0.25$.

TABLE 1. Probability P_k of at least k hits vs spacing I of n bombs in train; also maximum probability, \hat{P}_k and optimum spacing, \hat{I} . Target 1×6 , $\theta = 90^\circ$, $\sigma_a = 8$, $\sigma_d = 1$.

n	$k:$	1	2	3	4	5	n	$k:$	1	2	3	4	5
2	$\hat{I} \backslash \hat{P}$	3.45	0-0.60				8	$\hat{I} \backslash \hat{P}$	1.80	0-0.15	0	0	0-0.15
	$I \backslash \hat{P}$	0.028	0.003					$I \backslash \hat{P}$	0.091	0.031	0.015	0.006	0.002
	0.0	0.025	0.003					0.0	0.060	0.031	0.015	0.006	0.002
	0.15	0.025	0.003					0.15	0.062	0.031	0.014	0.005	0.002
	0.30	0.025	0.003					0.30	0.066	0.030	0.012	0.004	0.001
	0.45							0.45					
	0.60	0.026	0.003					0.60	0.077	0.027	0.007	0.001	0.000
	0.75							0.75					
	0.90							0.90					
	1.05							1.05					
	1.20	0.026	0.002					1.20	0.089	0.018	0.002	0.000	
	1.35							1.35					
	1.50							1.50					
	1.65							1.65					
	1.80	0.027	0.001					1.80	0.091	0.010	0.000		
	1.95							1.95					
	2.10							2.10					
2.25						2.25							
2.40	0.028	0.001				2.40	0.088	0.005					
2.55													
2.70													
2.85													
3.00	0.028												
3.15													
3.30													
3.45													
3.60	0.028												
4	$\hat{I} \backslash \hat{P}$	2.48	0-0.15	0-0.15	0-		12	$\hat{I} \backslash \hat{P}$	1.28	0.40	0	0	0
	$I \backslash \hat{P}$	0.052	0.013	0.003	0.000			$I \backslash \hat{P}$	0.123	0.047	0.027	0.016	0.008
	0.0	0.041	0.013	0.003				0.0	0.071	0.043	0.027	0.016	0.008
	0.15	0.042	0.013	0.003				0.15	0.076	0.045	0.026	0.014	0.007
	0.30	0.042	0.012	0.002				0.30	0.087	0.046	0.023	0.010	0.003
	0.45							0.45					
	0.60	0.044	0.011	0.002				0.60	0.108	0.043	0.013	0.003	0.000
	0.75							0.75					
	0.90							0.90					
	1.05							1.05					
	1.20	0.048	0.008	0.001				1.20	0.123	0.026	0.003	0.000	
	1.35							1.35					
	1.50							1.50					
	1.65							1.65					
	1.80	0.051	0.005	0.000				1.80	0.118	0.014	0.000		
	1.95							1.95					
	2.10							2.10					
2.25						2.25							
2.40	0.052	0.002				2.40	0.105	0.006					
2.55													
2.70													
2.85													
3.00	0.052												

borhood and re-estimated, making use of the information regarding the tangent.

By plotting the results in various ways, certain empirical generalizations may be made:

1. The maximum probability \hat{P}_1 (i.e., probability for best spacing) of at least one hit is greatest when the attack is directed across the target, i.e., $\theta = 90^\circ$. This rule is suggested by Figure 2. The rule, how-

TABLE 1. *Continued*

n	k :	1	2	3	4	5
16	\hat{I}	0.99	0-0.40	0-0.15	0	0
	\hat{P}	0.152	0.063	0.037	0.026	0.017
	0.0	0.078	0.052	0.037	0.026	0.017
	0.15	0.088	0.056	0.037	0.023	0.013
	0.30	0.107	0.062	0.033	0.015	0.006
	0.45					
	0.60	0.136	0.058	0.018	0.004	0.000
	0.75					
	0.90					
	1.05					
	1.20	0.148	0.033	0.003	0.000	
	1.35					
1.50						
1.65						
1.80	0.133	0.016	0.000			

n	k :	1	2	3	4	5
20	\hat{I}	0.84	0.40	0.16	0	0
	\hat{P}	0.173	0.079	0.046	0.033	0.025
	0.0	0.084	0.058	0.044	0.033	0.025
	0.15	0.100	0.066	0.046	0.031	0.020
	0.30	0.127	0.077	0.043	0.021	0.008
	0.45					
	0.60	0.162	0.071	0.023	0.005	0.001
	0.75					
	0.90					
	1.05					
	1.20	0.166	0.038	0.004	0.000	0.000
	1.35					
1.50						
1.65						
1.80	0.139	0.017	0.000			

TABLE 2. List of conditions for which the probabilities P_k of at least k hits with a train of n bombs have been computed. $k = 1, 2, \dots, 5; n = 2, 4, 8, 12, 16, 20$.

Target size	θ	σ_a	σ_d	I	
1 x 1	90°	0.25, 0.50, 1, 2, 4	0.125	0.0, 0.075, ..., 1.650	
1 x 3	90°	0.125, 0.25, 0.50, 1, 2	0.0625	0.0, 0.075, ..., 1.200	
1 x 6	90°	1, $\sqrt{2}$, 2, 2 $\sqrt{2}$, 4, 8	0.3	0.0, 0.2, ..., 2.2	
	0°	0.5, 1, 2	0.25	0.0, 0.225, 0.450, 0.675	
1 x 9	90°	1, 2, 4, 8, 16	0.5	0.0, 0.15, ..., 3.60	
	63°	1, 2, 4, 8, 16	0.5	0.0, 0.1675, ..., 2.3550	
	45°	1, 2, 4, 8, 16	0.5	0.0, 0.2125, ..., 4.2500	
	27°	1, 2, 4, 8, 16	0.5	0.0, 0.335, ..., 6.700	
	0°		1, 2, 4, 8, 16	0.5	0.0, 0.3, ..., 6.0

Note. The probabilities have not been computed for all possible combinations of the parameters.

ever, seems to be an outgrowth of the circumstance that the aiming-error distribution is characterized by equal standard deviations, σ_a , in range and in deflection. For if these standard deviations, say σ_{ar} and σ_{ad} , are unequal and if the bomb dispersion is negligible ($\sigma_d = 0$), then it can be demonstrated

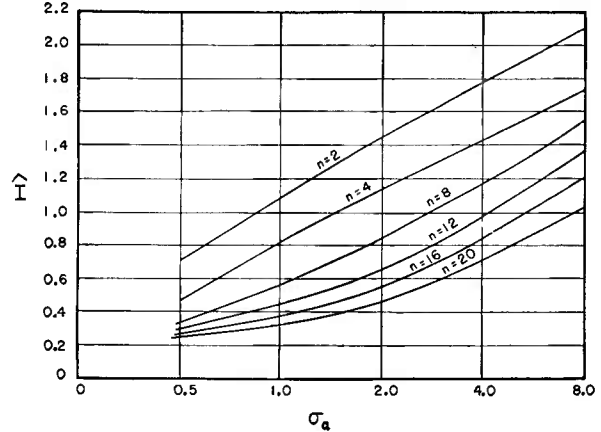

FIGURE 3. Optimum spacing \hat{I} for at least one hit vs standard deviation σ_a of aiming errors for various values of n , the number of bombs in train. Target 1×6 , $\theta = 90^\circ$, $\sigma_d = 0.3$.

that attacks along the target ($\theta = 0^\circ$) yield greater values of \hat{P}_1 than attacks across the target ($\theta = 90^\circ$) when $\sigma_{ar}/\sigma_{ad} > n$, and conversely when $\sigma_{ar}/\sigma_{ad} < n$, where $n =$ the number of bombs in train.

2. The optimum spacing \hat{I} of bombs in train increases when the standard deviation σ_a of the aiming errors increases. This is illustrated by Figure 3. The dependence of \hat{I} on the bomb-dispersion distribution is less simple. Consider a given set of conditions, including a non-zero value of σ_d ; \hat{I} will have a value which may be greater or may be less than the target width W . Now as σ_d approaches zero, \hat{I} approaches W .



3.3 PROBABILITIES OF HITTING
RECTANGULAR TARGETS WITH MULTIPLE
ATTACKS

Heretofore the discussion has concerned the probability of obtaining at least k hits as the result of a single attack with a train of n bombs. The extension to attacks in which more than one aircraft participates is now reviewed. It is likely, from qualitative considerations, that the probability of hitting, considered as a function of the spacing, depends in a non-trivial manner on the number of independent attacks.

Purpose of the Study. The present objective is to examine this question and, if the situation is as it is expected to be, to perform the necessary calculations leading to basic tables for multiple attacks against a

single target. Once these are at hand questions relating to the attack of several targets may be investigated. For example, the questions arise: How should a given number of aircraft be allocated among several targets? And how many aircraft can be dispatched, economically, against each target?

The qualitative considerations mentioned above are illustrated here. Suppose one wishes to maximize the probability of obtaining at least four hits when 4-bomb trains are used. If only one attack is to be made, it is not difficult to guess that the best spacing may be $I = 0$. But suppose that the best spacing to achieve at least *one* hit is quite different from $I = 0$, and suppose that the corresponding maximum probability \hat{P}_1 is substantially greater than the value of P_1 for spacing zero. Now, under these conditions, consider the problem of obtaining at least four hits

TABLE 3. Probabilities of at least k hits when s independent attacks are made, each with a train of 8 bombs spaced at the interval I . Target 1×6 , $\theta = 90^\circ$, $\sigma_a = 2$, $\sigma_d = 0.3$.

k	I	$s =$	1	2	3	4	5	6	7	8	9	10
1	0.0		0.318	0.535	0.683	0.784	0.853	0.900	0.931	0.953	0.968	0.978
	0.2		0.429	0.674	0.813	0.893	0.939	0.965	0.980	0.989	0.994	0.996
	0.4		0.577	0.821	0.924	0.968	0.987	0.994	0.998	0.999	1.000	1.000
	0.6		0.673	0.893	0.965	0.989	0.996	0.999	1.000	1.000	1.000	1.000
	0.8		(0.706)	(0.914)	(0.975)	(0.993)	(0.998)	(0.999)	(1.000)	(1.000)	(1.000)	(1.000)
	1.0		0.692	0.905	0.971	0.991	0.997	0.999	1.000	1.000	1.000	1.000
2	0.0		0.258	0.453	0.599	0.708	0.788	0.847	0.889	0.920	0.943	0.959
	0.2		0.336	0.568	0.723	0.825	0.890	0.931	0.958	0.974	0.984	0.990
	0.4		(0.414)	0.683	0.837	0.919	0.961	0.981	0.991	0.996	0.998	0.999
	0.6		0.360	(0.688)	(0.864)	0.945	0.978	0.992	0.997	0.999	1.000	1.000
	0.8		0.239	0.639	0.854	(0.945)	(0.980)	(0.993)	(0.998)	(0.999)	(1.000)	(1.000)
	1.0		0.129	0.558	0.810	0.925	0.972	0.989	0.996	0.999	1.000	1.000
3	0.0		0.218	0.395	0.536	0.644	0.733	0.799	0.850	0.888	0.919	0.939
	0.2		(0.256)	(0.467)	0.630	0.748	0.831	0.888	0.927	0.953	0.970	0.981
	0.4		0.190	0.467	(0.683)	0.822	0.905	0.951	0.975	0.987	0.994	0.997
	0.6		0.061	0.395	0.673	(0.840)	(0.927)	(0.968)	(0.987)	0.995	0.998	0.999
	0.8		0.010	0.286	0.602	0.809	0.916	0.966	0.987	(0.995)	(0.998)	(0.999)
	1.0		0.001	0.163	0.481	0.730	0.873	0.944	0.977	0.991	0.996	0.999
4	0.0		(0.183)	0.343	0.477	0.586	0.679	0.751	0.809	0.854	0.893	0.916
	0.2		0.172	(0.356)	(0.521)	0.654	0.756	0.831	0.885	0.917	0.948	0.966
	0.4		0.041	0.268	0.506	(0.691)	0.818	0.897	0.944	0.970	0.984	0.992
	0.6		0.002	0.169	0.439	0.672	(0.825)	(0.913)	(0.959)	(0.981)	(0.992)	(0.997)
	0.8		0.000	0.066	0.309	0.577	0.774	0.890	0.950	0.979	0.991	0.996
	1.0		0.000	0.018	0.169	0.428	0.662	0.821	0.912	0.960	0.982	0.993
5	0.0		(0.150)	(0.292)	(0.421)	0.527	0.623	0.701	0.764	0.816	0.864	0.889
	0.2		0.089	0.240	0.400	(0.544)	0.664	0.758	0.828	0.875	0.917	0.944
	0.4		0.002	0.136	0.342	0.543	(0.703)	(0.818)	0.893	0.939	0.966	0.981
	0.6		0.000	0.041	0.227	0.466	0.671	0.815	(0.902)	(0.951)	(0.976)	(0.989)
	0.8		0.000	0.005	0.104	0.321	0.559	0.745	0.866	0.934	0.969	0.986
	1.0		0.000	0.000	0.031	0.168	0.387	0.604	0.770	0.877	0.938	0.971

Note. Parentheses mark the probability which is greatest in each column.

TABLE 4. List of conditions for which the probability P_{ks} of at least k hits in s attacks with a train of n bombs have been computed. $k = 1, 2, \dots, 5$; $n = 2, 4, 8, 12, 16, 20$.

Target size	θ	σ_a	σ_d	I	s
1×1	90°	0.25, 0.50, 1, 2, 4	0.125	0.0, 0.075, \dots , 1.650	1, 2, \dots , 10
1×3	90°	0.125, 0.25, 0.50, 1, 2	0.0625	0.0, 0.075, \dots , 1.200	1, 2, \dots , 10
1×6	90°	$1, \sqrt{2}, 2, 2\sqrt{2}, 4, 8$	0.3	0.0, 0.2, \dots , 2.2	1, 2, \dots , 48
	0°	0.5, 1, 2	0.25	0.0, 0.225, 0.450, 0.675	1, 2, \dots , 25
1×9	90°	1, 2, 4, 8, 16	0.5	0.0, 0.15, \dots , 3.60	1, 2, \dots , 10
	63°	1, 2, 4, 8, 16	0.5	0.0, 0.1675, \dots , 2.3550	1, 2, \dots , 10
	45°	1, 2, 4, 8, 16	0.5	0.0, 0.2125, \dots , 4.2500	1, 2, \dots , 10
	27°	1, 2, 4, 8, 16	0.5	0.0, 0.335, \dots , 6.700	1, 2, \dots , 10
	0°	1, 2, 4, 8, 16	0.5	0.0, 0.3, \dots , 6.0	1, 2, \dots , 10

Note. The probabilities have not been computed for all possible combinations of the parameters.

in, say, four, five, or ten attacks with 4-bomb trains. Intuition suggests that it may be more profitable to space the bombs in each train so as to try to achieve the four hits one by one, rather than to try to get all four each time an attack is made.

Method of Analysis. The method of analysis was to let P'_k be the probability of exactly k hits with one train of n bombs (as distinct from P_k which has been used to designate the probability of at least k hits) and let P_{ks} be the probability of at least k hits with s trains of n bombs. Then

$$P_{ks} = 1 - \sum_{j=0}^{k-1} \frac{1}{j!} \left[\frac{d^j}{dx^j} \left(\sum_{i=0}^n P'_i x^i \right)^s \right]_{x=0} \quad (6)$$

It is easy to show that when $k = 1$ the spacing I which maximizes P_1 also maximizes P_{1s} , but that when $k > 1$, this is not true. Hence, the character of the probability curve, $P_{ks}(I)$, depends on s and it is necessary to perform additional calculations.

The questions regarding the best allocation of aircraft are investigated by calculating probability averages with respect to the mission, the bomber life-time, etc. Certain of these require quite elaborate mathematical descriptions and depend on a number of a priori hypotheses, the practical validity of which are unknown. However, the importance of this part of the study does not depend on the validity of the particular hypotheses adopted for discussion; rather, it stems from the light that is thus thrown on the subject of large-scale bombing, for it is brought out that the best bombing policy may depend sensitively on the exact formulation of the short- and long-term objectives of the Air Forces.

Results. The results of calculation for multiple attacks are presented in tables of the form of Table 3;

these are in fact identical with those for single attacks, except for the presence of the parameter s . Certain of the values in Table 3 are graphed in Figure 4.

Calculations have been made for the various sets of conditions itemized in Table 4. Actually this is a more restricted calculating program than that for single attacks, outlined in Table 2. There are two

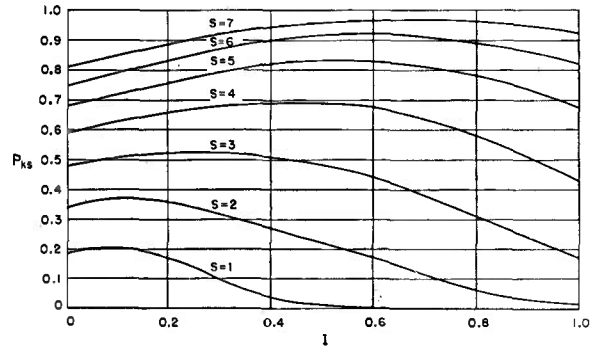

FIGURE 4. Probability P_{ks} of at least k hits with s trains of n bombs vs spacing I , when $k = 4$, $n = 8$, target 1×6 , $\theta = 90^\circ$, $\sigma_a = 2$, $\sigma_d = 0.3$.

reasons for this: (1) Many of the questions of primary interest could be answered satisfactorily from the probabilities at hand, and (2) in the field, the importance of train bombing had been, by then, completely overshadowed by that of pattern bombing, and in 1944 AMP curtailed its work on train bombing.

Figure 5 illustrates the fact that, as anticipated, the optimum spacing \hat{I} depends on the number s of attacks as well as on the number n of bombs in train. In this example $s_{0.90}$ is the number of attacks needed to yield a probability of 0.90 that at least 5 hits will be made on a 1×6 target, when the standard

deviations, σ_a and σ_d , are 4 and 0.3, respectively. Figure 6 illustrates the dependence of $s_{0.90}$ on the values of σ_a and n .

Consider the problem of allocating attacks so as to maximize the effectiveness (i.e., the number of targets hit at least k times) of the attacking force. If the force is fixed in size it is evident that this allocation will be such that the effectiveness of each attacking aircraft is a maximum, which suggests that a new table be prepared by dividing by s each of the maximum probabilities \hat{P}_{ks} in a list like Table 3. Table 5 has been prepared in this manner. From inspection of tables of this type it appears that single attacks are most efficient, according to the very simple criterion used, when the number n of bombs in train exceeds the number k of hits required, and that mul-

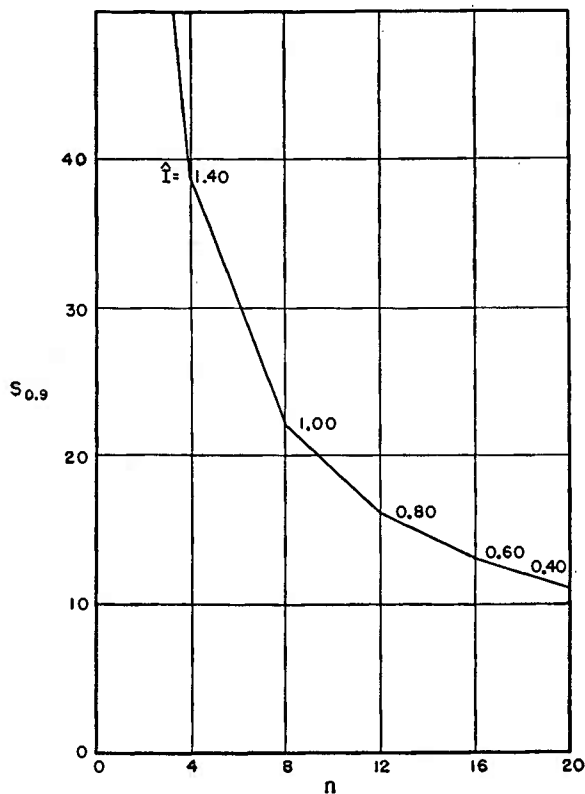

FIGURE 5. Plot of $s_{0.90}$ vs n , number of bombs in train. \hat{I} is the optimum spacing, and $s_{0.90}$ is the number of attacks needed to yield a probability of 0.90 that at least 5 hits will be made on a target. Target 1×6 , $\theta = 90^\circ$, $\sigma_a = 4$, $\sigma_d = 0.3$.

iple attacks are needed when the number n of bombs in train is less than or equal to the number k required.

The last result is not exactly a discovery, but it is saved from being trivial by the facts that the optimum number \hat{s} of attacks is not the least possible

and that the yield, \hat{P}_{ks}/\hat{s} , is sometimes spectacularly greater than that for other, and apparently reasonable, values of s . For example, with $n = 2$ and $k = 5$, threefold attacks ($s = 3$) yields $P_{5,3}/3 = 0.00185$, whereas the use of 21 attacks per target yields

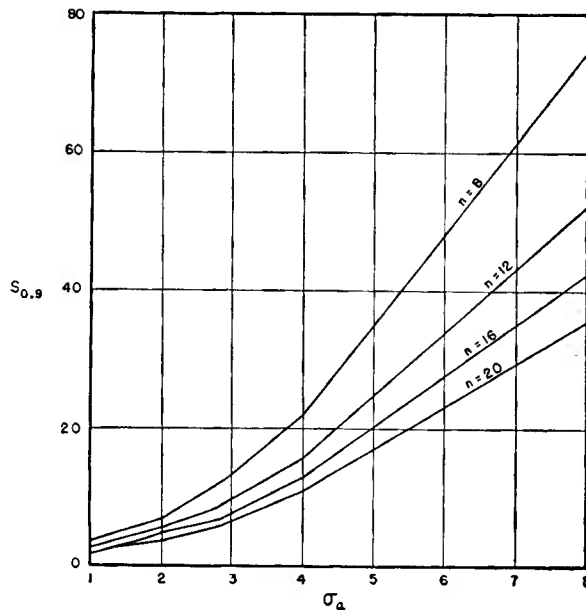

FIGURE 6. Plot of $s_{0.90}$ vs σ_a , where $s_{0.90}$ is number of attacks needed to make \hat{P}_{ks} ($k = 5$) equal to 0.90 for various values of n , the number of bombs in train. Target 1×6 , $\theta = 90^\circ$, $\sigma_d = 0.3$.

$P_{5,21}/21 = 0.04010$. Thus in this case it is more than 20 times as effective to allocate 21 aircraft to a target as it is to allocate 3 aircraft to each of 7 targets.

Analyses similar to the above have been made in which the optimum number s' of aircraft to dispatch to each target, as opposed to the number s to attack, is estimated on the basis of various assumptions regarding the loss-rates, and regarding short- and long-term values which depend on the replacement rate. As a single illustration of these more complex situations, consider the problem of determining the number s' of aircraft to dispatch to each target in order that each aircraft will destroy as many targets as possible, say $L_{ks'}$, during its lifetime. Assume that the probability that an aircraft will be lost at any moment depends linearly on the reciprocal of the number of aircraft present, during the combat phase of the mission, and that it is zero at other times. The expected number of targets destroyed is determined from

$$L_{ks'} = \frac{\sum_{s=1}^{s'} C_{s's} P_{ks}}{s'(1 - C_{s'})} \quad (7)$$

where C_s is the probability that a specified aircraft will survive a mission on which s' were dispatched, and $C_{s's}$ is the probability that it will be one of the s which will survive to the target. Table 6 gives the results for a sample computation.

The multiple-attack tables and related discussions are contained in a number of AMP documents.^{3,4,8-12}

3.4 EMPIRICAL RULES FOR BOMB SPACING IN HITTING RECTANGULAR TARGETS

The extensive sets of tables and graphs described in the two preceding studies are intended as basic reference material. They are not immediately useful, usually, for solving specific problems, for their use would involve interpolation (often nonlinear) in six dimensions. An attempt to use them in this way

would probably be a frustrating experience, climaxed by the discovery that one or another parameter had to be extrapolated.

However, this material is a uniquely valuable source of general information for train-bombing problems. An important use is for the discovery of approximate, but unbiased, rules which may be applied to a variety of situations.

As an example of this, AMP, at the request of the Armament Laboratory, Wright Field Proving Ground, undertook to develop a calculator which would indicate the optimum spacing for bombs dropped in train. This work is summarized in the following paragraphs.

Purpose of the Study. The purpose of the study is to determine the spacing \hat{I} for bombs in train, which will maximize the probability of achieving at least k hits on rectangular targets.

TABLE 5. Part of probability P_{ks}/s , of hitting at least k times, ascribable to each bomber of s attacking planes. (All values have been multiplied by 100.) Target 1×6 , $\theta = 90^\circ$, $\sigma_a = 2$, $\sigma_d = 0.3$.

n	k	$s =$	1	2	3	4	5	6	7	8	9	10	11
2	1	31.1	26.3	22.4	19.4	16.9	14.9	13.2	11.9	10.7	9.76	8.94	
	2	11.0	11.1	10.9	10.6	10.3	10.2	10.0	9.63	9.18	8.70	8.21	
	3		1.89	3.31	4.35	5.10	5.64	6.00	6.24	6.48	6.60	6.60	
	4		0.604	1.27	1.93	2.54	3.07	3.53	3.90	4.20	4.42	4.57	
	5			0.185	0.492	0.867	1.27	1.68	2.07	2.43	2.75	3.02	
4	1	51.2	38.1	29.5	23.6	19.4	16.4	14.2	12.5	11.1	10.0	9.09	
	2	21.1	20.2	19.2	18.4	16.9	15.2	13.6	12.2	10.9	9.92	9.05	
	3	13.4	13.2	12.8	12.4	12.3	12.3	11.8	11.2	10.4	9.62	8.89	
	4	6.39	7.66	8.41	8.87	8.95	8.99	9.27	9.35	9.17	8.84	8.41	
	5		2.26	3.92	5.17	5.92	6.51	6.90	7.24	7.50	7.59	7.55	
8	1	70.6	45.7	32.5	24.8	20.0	16.7	14.3	12.5	11.1	10.0		
	2	41.3	34.4	25.5	23.6	19.6	16.6	14.3	12.5	11.1	10.0		
	3	25.6	23.4	22.7	21.0	18.5	16.1	14.1	12.4	11.1	10.0		
	4	18.3	17.8	17.4	17.2	16.5	15.2	13.7	12.3	11.0	10.0		
	5	15.0	14.6	14.0	13.6	14.0	13.6	12.9	11.9	10.8	9.89		
n	k	$s =$	12	13	14	15	16	17	18	19	20	21	22
2	1	8.24	7.63	7.10	6.64	6.23	5.87	5.55	5.26	5.00	4.76	4.54	
	2	7.74	7.29	6.87	6.48	6.12	5.79	5.50	5.22	4.97	4.74	4.53	
	3	6.51	6.36	6.18	5.97	5.74	5.52	5.29	5.07	4.86	4.66	4.48	
	4	4.74	4.88	4.96	4.99	4.97	4.90	4.81	4.70	4.58	4.44	4.31	
	5	3.25	3.44	3.59	3.72	3.86	3.96	4.02	4.04	4.04	4.01	3.96	
4	1	8.33	7.69	7.14	6.67	6.25	5.88	5.56	5.26	5.00			
	2	8.31	7.68	7.14	6.66	6.25	5.88	5.56	5.26	5.00			
	3	8.22	7.63	7.11	6.65	6.24	5.88	5.55	5.26	5.00			
	4	7.94	7.47	7.02	6.60	6.21	5.86	5.54	5.26	5.00			
	5	7.34	7.07	6.76	6.44	6.12	5.80	5.52	5.24	4.99			

TABLE 6. Expected number of targets hit at least k times each by each bomber during its lifetime, when s' are dispatched on each mission. Risk to bomber at any moment of combat depends linearly on the reciprocal of the number of aircraft present; normalization such that probability of surviving a single-aircraft mission is 0.7. Target 1×6 , $\theta = 90^\circ$, $\sigma_a = 2$, $\sigma_d = 0.3$.

n	k	$s' =$	1	2	3	4	5	6	7	8	9	10	11	12
4	1		1.43	1.88	2.18	2.31	2.35	2.35	2.32	2.28	2.24	2.20	2.15	2.11
	2		0.59	0.98	1.39	1.76	2.01	2.15	2.20	2.22	2.20	2.18	2.14	2.10
	3		0.37	0.64	0.93	1.18	1.44	1.71	1.90	2.02	2.08	2.10	2.10	2.08
	4		0.18	0.37	0.60	0.84	1.05	1.24	1.47	1.67	1.82	1.91	1.97	2.00
	5			0.10	0.27	0.48	0.69	0.90	1.09	1.28	1.47	1.63	1.75	1.84
8	1		1.97	2.27	2.42	2.45	2.42	2.38	2.34	2.29	2.24	2.20		
	2		1.15	1.67	2.11	2.31	2.37	2.36	2.33	2.29	2.24	2.20		
	3		0.71	1.14	1.64	2.02	2.22	2.29	2.30	2.28	2.24	2.19		
	4		0.51	0.86	1.25	1.64	1.95	2.20	2.22	2.24	2.22	2.19		
	5		0.41	0.71	1.01	1.29	1.64	1.90	2.07	2.16	2.18	2.17		

Having determined the optimum spacing as a function of the various parameters, it is desired to present this in a form suitable for rapid calculation.

Method of Analysis. In the analysis, as an aid to the discovery of an approximate rule, two quantities are read from each graph of the type of Figure 1,

namely, the spacings, \underline{I} and \bar{I} , on either side of the optimum spacing \hat{I} , which correspond to probabilities of magnitude $0.99\hat{P}_k$. Then any value of the spacing in the range from \underline{I} to \bar{I} may safely be identified with the optimum spacing, \hat{I} , without missing the maximum probability by more than one per cent.

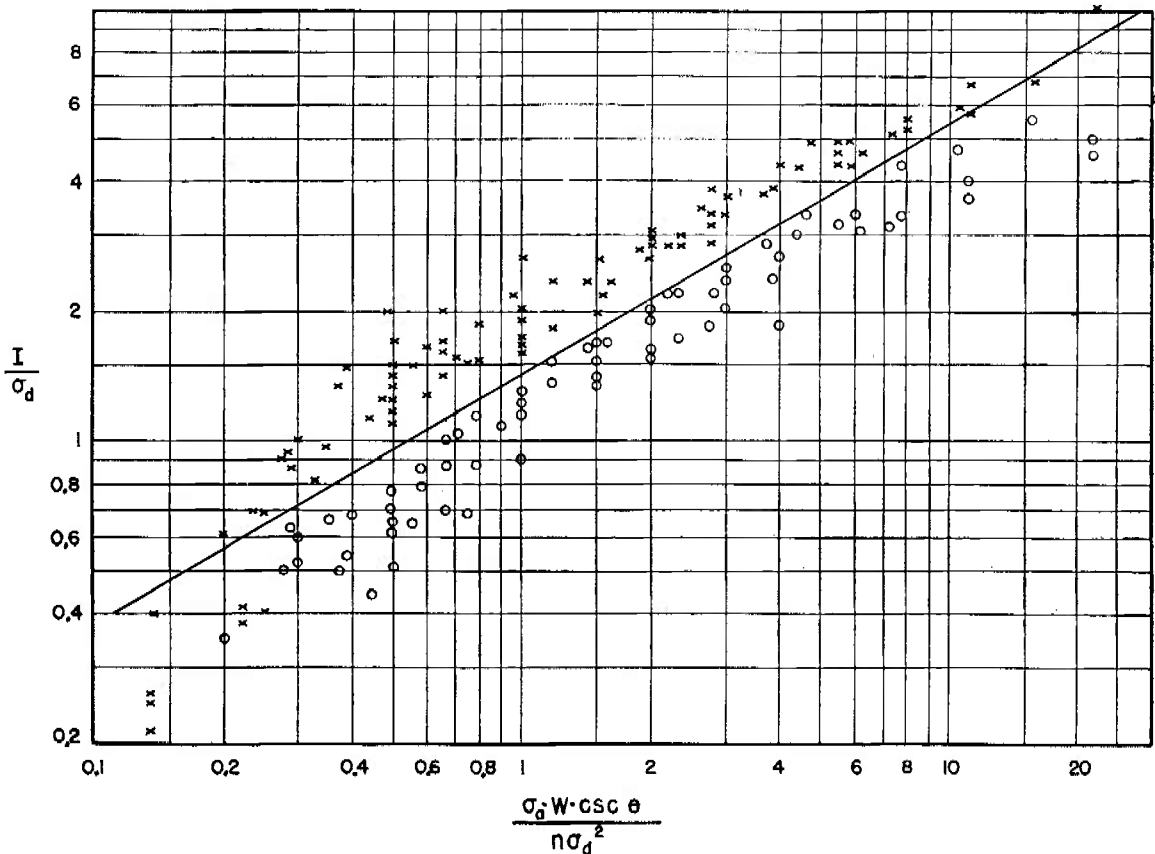

FIGURE 7. Scatter chart showing the empirical invariant on which the *Bomb-Spacing Calculator* is based. Circles and crosses correspond to the least and greatest spacings, respectively, which lead to probabilities of $0.99\hat{P}_k$.

One now tries to synthesize a rule, assisted by this latitude thus introduced into the definition of \hat{I} and by qualitative considerations. For example, it is evident that the spacing will increase as the target dimensions increase, as the angle of attack decreases,

dimensions expressed in terms of target width as unit), one obtains a scatter chart like Figure 7. From the chart one sees that, over substantial ranges of the variables, the two sets of points are nicely sorted by the straight line, which represents equation (8).

Results. The study resulted in the development of the *Bomb-Spacing Calculator* (see Figure 8), which mechanizes equation (8). It is a circular slide rule designed to provide estimates of the best spacing, i.e., that spacing which maximizes the probability of at least one hit, in any number of train attacks against rectangular targets. It has been calibrated with special reference to ship targets. A few of the details of the calibration follow. Figures 9 and 10

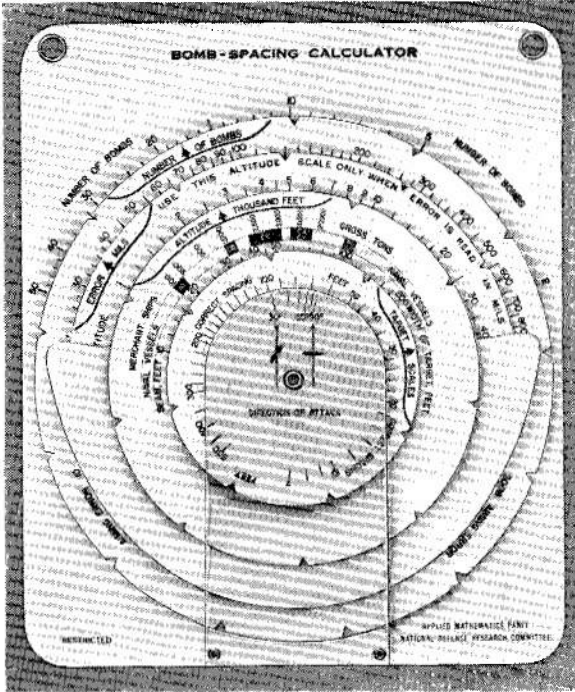

FIGURE 8. Photograph of AMP *Bomb-Spacing Calculator*.

as the standard deviation of the aiming-error distribution increases, and as the number of bombs decreases.

From this type of argument the following specific function has finally arisen for consideration:

$$\frac{\hat{I}}{\sigma_d} = C_1 \left(\frac{\sigma_a W \csc \theta}{n \sigma_d^2} \right)^{C_2} \quad (8)$$

Here the optimum spacing \hat{I} is expressed as an empirical function of the standard deviations, σ_a and σ_d , of the aiming-error and bomb-dispersion distributions; of the angle θ of attack, measured from the long target-axis to the track of the attacking aircraft; of the target width W ; of the number n of bombs in train; and of two constants, C_1 and C_2 , which will be so chosen as to give the best fit.

Plotting first \hat{I} and then \bar{I} against the expression in parentheses in equation (8) for all at-least-one-hit data on hand, namely, that corresponding to targets of the shapes 1×6 and 1×9 , $\frac{1}{2} \leq \sigma_a \leq 8$, $\frac{1}{4} \leq \sigma_d \leq 3$, $27^\circ \leq \theta \leq 90^\circ$, $2 \leq n \leq 20$ (all linear

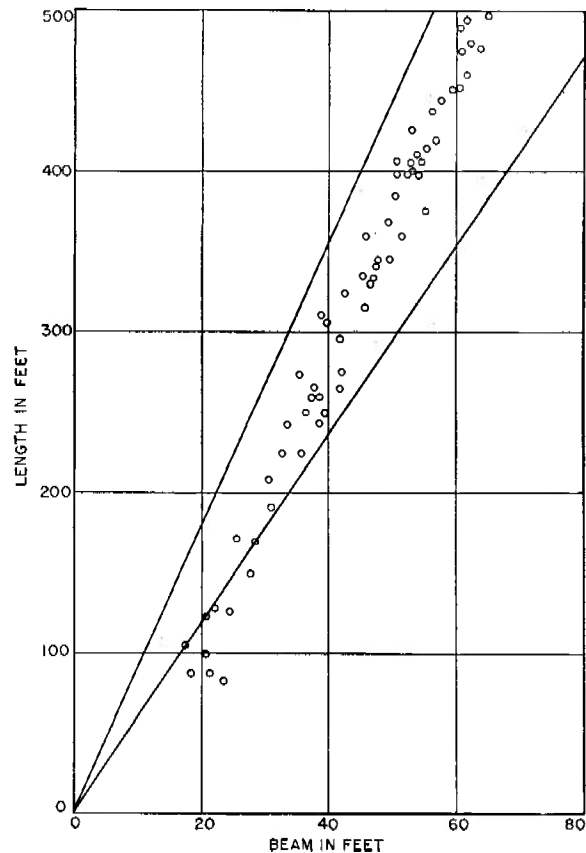

FIGURE 9. Scatter chart of length vs beam for a sample of Japanese merchantmen.

are scatter charts showing the relationship between length and beam, and gross tonnage and beam, for Japanese merchantmen. From the first, one sees that most of these ships have length-to-width ratios which fall comfortably within the target limits on which Figure 4 is based; the second provides a ready calibration based on tonnage.

The component standard deviations, σ_a , of the aiming-error distribution are replaced by a new aiming-error statistic whose value lies midway between that of the so-called circular probable error ($CEP = 1.18\sigma_a$) and that of the mean radial error

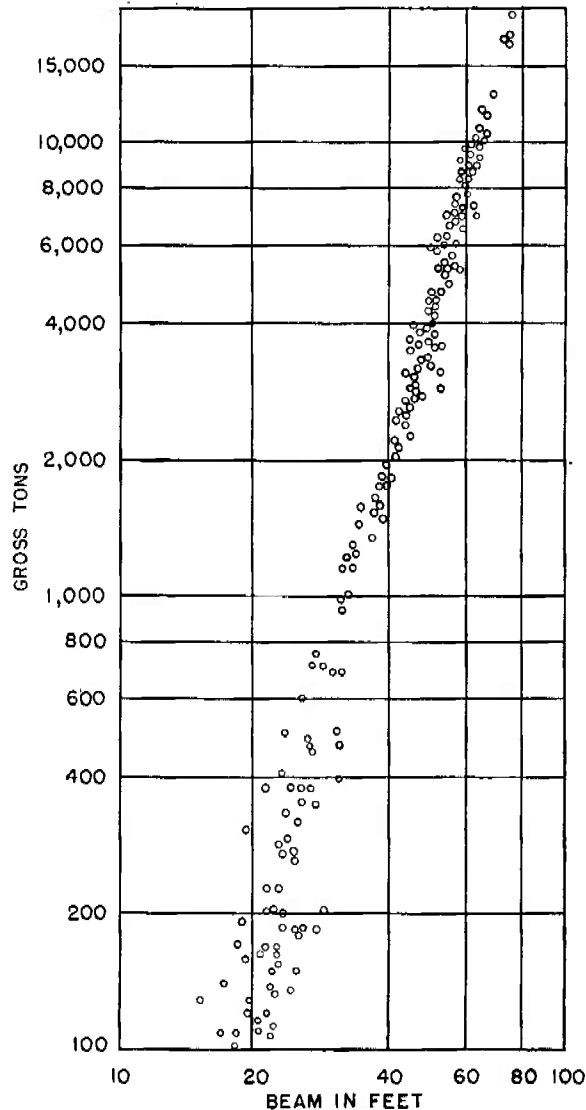

FIGURE 10. Scatter chart of gross tonnage vs beam for a sample of Japanese merchantmen.

($MRE = 1.25\sigma_a$). Thus the aiming-error statistic will not be biased by more than 3 per cent if the slide rule is entered with CEP or with MRE .

The bomb-dispersion statistic is contained implicitly: It is assumed that σ_d is proportional to the square root of the altitude (available data support this weakly, but then the slide rule depends only weakly on the assumption), the proportionality fac-

tor being chosen so as to yield $\sigma_d = 30$ ft when the altitude is 10,000 ft.

The bomb-spacing calculator has been manufactured in sufficient quantities to permit distribution to operations analysts and other personnel in the Services who have had use for the device.

The best spacing for at least k hits, when $k > 1$, has not been mechanized; indeed it has not been studied extensively. But from study of a limited set of calculations in which the bomb dispersion, σ_d , was substantially less than target width W , a few hints have been obtained. For single attacks and for $k > n/2$, the best spacing is zero; for $1 < k < n/2$ the best spacing is approximately W/k , but the best spacing is always less than that for $k = 1$. As the number s of attacks is increased, the best spacing increases, until it reaches the value for at least one hit; in the cases examined this occurred at moderate values of s , like $s = 10$ or 20.

An interesting side light on the single-attack case is provided by the following observation. The probability P_k of at least k hits may of course be written as

$$P_k = \sum_{i=k}^n P'_i, \quad (9)$$

where P'_i is the probability of exactly i hits. It has been observed that the spacing which maximizes P'_i does not depend on the aiming-error standard deviation, σ_a , except when $i = 1$. Hence, the best spacing in single attacks does not depend on the aiming-error statistic when $k > 1$.

For the basic probabilities, reference may be made to the reports listed in sections 3.2 and 3.3 of this chapter. Discussions, often brief, of the best spacing for at least k hits against a single target are contained in AMP working papers^{13,14,15} and an AMP report.³

3.5 EMPIRICAL RULES FOR DETERMINING THE PROBABILITIES OF HITTING RECTANGULAR TARGETS

The bomb-spacing calculator described in Section 3.4 under *Results* shows the best way to space a train of bombs, from the viewpoint of at least one hit, but it does not indicate how good this best way is, measured in probabilities. The present study concerns an attempt to provide such estimates. However, it was undertaken at a time when the importance of this phase of the work was judged to be

secondary; consequently, the specifications were not made very stringent.

Purpose of the Study. The purpose of the study is to try to provide a simple method, or device, for estimating the probability P_{ks} of at least k hits when s attacks are made on a single target, or, conversely, of the number s of attacks needed in order to have P_{ks} attain a specified value.

From the viewpoint of subsequent mechanization it is highly desirable that an empirical formula be developed which can be written as a product of factors, each of which depends on only one of the parameters $s, k, n,$ etc.

Method of Analysis. Two analyses of this type have been made, one based on

$$g_1(s) = g_2(P_{ks})g_3(k)g_4(n)g_5(\sigma_a), \quad (10)$$

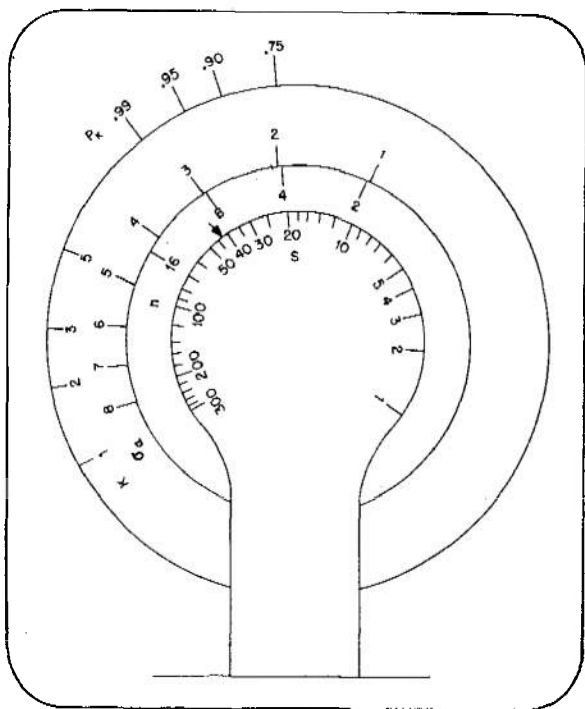

FIGURE 11. Design of multiple-attack multiple-hit slide rule. $T = 1 \times 6, \theta = 90^\circ, \sigma_d = 0.3.$

for a given target and σ_d , with emphasis on values of $P_{ks} \geq 0.75$; and one based on

$$P_{ks} = C_1 \left[\frac{nsW^2}{\sigma_d^2} \right]^{C_2}, \quad (11)$$

for $k = 1$, targets 1×6 and 1×9 , and for $\sigma_d \leq 2.$

Results. As a result of the study of spacing, the functions $g_i (i = 1, \dots, 5)$ in equation (10) have been determined empirically for the 1×6 target, $\sigma_d = 0.3$; and a mockup of a multiple-attack mul-

multiple-hit slide rule, based on that equation, has been constructed. This is exhibited in Figure 11. When used to estimate s the error rarely exceeds 20 per cent. To use the slide rule, the selected value of k on the k scale is matched against the selected value of P_k

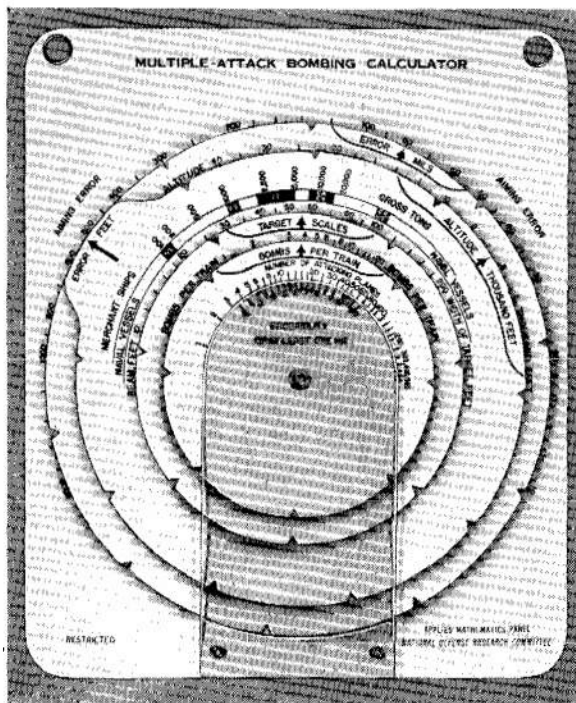

FIGURE 12. Photograph of AMP Multiple-Attack Bombing Calculator.

on the P_k scale. The appropriate value of n is then matched against the value of σ_a . The arrow will then indicate the value of s , the number of attacks to make.

The constants C_1 and C_2 in equation (11) have been determined from data covering a wider range of values of P_{ks} than was used in equation (10), and from all the data at hand regarding ship-like rectangular targets. The equation has been mechanized in a slide rule known as the *Multiple-Attack Bombing Calculator*, shown in Figure 12. When used to estimate s , errors as great as 50 per cent have been observed.

This slide rule was deliberately restricted to the problem of at least one hit ($k = 1$) in order that it could be used freely, with little danger of misuse, as a comparison instrument to the bomb-spacing calculator (see Section 3.4 under *Results*); the latter gives the spacing which maximizes the probability of at least one hit ($k = 1$).

The multiple-attack bombing calculator has been manufactured in quantities sufficient to permit dis-

tribution to operations analysts and other personnel in the Services who have need for the instrument.

Documents by AMP's Bombing Research Group [BRG] cover the study discussed in this section in greater detail.^{11,12,13.}

3.0 MISCELLANEOUS INVESTIGATIONS OF PROBABILITIES OF HITTING RECTANGULAR TARGETS

There are discussed here a number of auxiliary questions which arose in the course of the train-bombing investigations, questions which still seem to have value. No mention is made of those questions of transitory interest on which, in an extended investigation, time is inevitably dissipated.

Purpose of the Study. The object of the study was to answer the four auxiliary questions listed here:

1. *Efficiency.* How do the probabilities of hitting in train bombing compare with those for certain other

TABLE 7. The probabilities of at least one hit when n bombs are released 1, 2, 4, or n per bombing run. The train releases are made at optimum spacing. Target 1×6 , $\theta = 90^\circ$, $\sigma_a = 8$, $\sigma_d = 0.5$.

Total bombs n	Number of bombs released per bombing run			
	1	2	4	n
1	0.01			0.01
2	0.03	0.03		0.03
4	0.06	0.06	0.06	0.06
8	0.11	0.11	0.11	0.10
12	0.16	0.16	0.16	0.14
16	0.21	0.21	0.21	0.17
20	0.25	0.25	0.25	0.20

methods in which the same number of bombs and/or aircraft are employed?

2. *Offset.* How serious is the effect of aiming the first bomb of a train at target center instead of aiming the center of the train?

3. *Errors.* How seriously will mis-estimates of the standard deviation σ_a affect the planning and execution of a mission?

4. *Combat data.* How may these standard deviations σ_a be estimated from combat data?

Method of Analysis. The methods of analysis are either evident from the discussion of the preceding studies, or implicit in the results which will be exhibited.

Results. The results of the study are listed as answers to the four questions presented in *Purpose of the Study.*

1. *Efficiency.* We shall compare the probabilities of at least one hit when the same total of bombs is dropped in various ways (but under the same con-

TABLE 8. Comparison: 12-aircraft formation vs s independent attacks with trains of 12 bombs from point of view of probability of at least one hit. Modeled on high-altitude combat data, $\theta = 90^\circ$.

σ_a	σ_d	Target	12-aircraft formation				
			$s=1$	$s=5$	$s=6$	$s=7$	$s=8$
8	0.86	1×9	0.62	0.18	0.62		
		1×6	0.58	0.12	0.49	0.55	0.61
16	1.7	1×9	0.26	0.05		0.26	0.30
		1×6	0.19	0.03		0.18	0.20

ditions regarding aiming errors, etc.), namely, single releases, trains of two bombs each, trains of four, and a single train containing all the bombs.

The calculations show that the tendency is for the probability to decrease when there are fewer aiming operations. However, when n is small there is usually very little difference between the probability of at least one hit with n single releases and that with one train of n bombs; for large values of n the difference more often becomes sizeable. Also, there are cases in

TABLE 9. Probability of at least k hits with s trains of 8 bombs when (a) train center and (b) the first bomb are aimed at target center. Target 1×6 , $\theta = 90^\circ$, $\sigma_a = 2$, $\sigma_d = 0.3$.

k	I	$s = 1$		$s = 2$		$s = 4$		$s = 8$	
		(a)	(b)	(a)	(b)	(a)	(b)	(a)	(b)
1	0.4	0.58	0.48	0.82	0.73	0.97	0.93	1.00	1.00
	0.8	0.71	0.47	0.91	0.72	0.99	0.92	1.00	0.99
2	0.4	0.41	0.34	0.68	0.58	0.92	0.85	1.00	0.98
	0.8	0.24	0.14	0.64	0.38	0.94	0.73	1.00	0.96
3	0.4	0.19	0.15	0.47	0.37	0.82	0.71	0.99	0.96
	0.8	0.01	0.00	0.29	0.12	0.81	0.47	1.00	0.89
4	0.4	0.04	0.03	0.27	0.19	0.69	0.56	0.97	0.91
	0.8	0.00	0.00	0.07	0.02	0.58	0.24	0.98	0.75
5	0.4	0.00	0.00	0.14	0.09	0.54	0.40	0.94	0.85
	0.8	0.00	0.00	0.00	0.00	0.32	0.09	0.93	0.57

which a train is definitely better than the same number of bombs released singly, a point which has not been generally appreciated. Table 7 is a typical example selected from a set of similar tables.

Comparison may also be made between independently aimed trains and trains dropped on the leader's signal. Table 8 shows the number of independently aimed trains required to match a combat box of 12 aircraft dropping on the leader. This example is modeled on the Eighth Air Force's experience in the European Theater of Operations.

2. *Offset.* The effect on P_k , the probability of at least k hits, of aiming the first bomb of a train instead of aiming the train center is always deleterious and at times serious. However, no simple general

TABLE 10. Number s of attacks needed to insure that maximum probability \hat{P}_{ks} of at least k hits will exceed 0.90. Target 1×6 , $\theta = 0^\circ$, $\sigma_d = 0.25$.

k	$\sigma_a = 1$			$\sigma_a = 2$		
	$n = 2$	$n = 4$	$n = 8$	$n = 2$	$n = 4$	$n = 8$
1	4	3	3	10	8	7
2	6	4	4	14	10	8
3	8	5	4	18	12	9
4	10	6	4	23	14	10
5	11	7	5	>25	17	11

rule has been discovered for isolating the serious cases, in which the biased aiming operation may reduce P_k by one-half or more. Table 9 shows a sample comparison of the two methods of aiming.

It should be noted that these comparisons are based on the assumption that the aiming-error distribution, relative to its mean, is the same with each method of aiming. In view of the limitations imposed by our bombsights, the aiming-error statistic σ_a is probably larger when train center is aimed; hence, calculations such as those displayed in Table 9 tend at present to overestimate the importance of the effect.

3. *Errors.* Mis-estimates of the distribution-function parameters, σ_a and σ_d , can be expected to produce two effects: (1) the mission planning will be upset in that an improper force will be assigned to the target; (2) the force assigned will not, because of mis-information, do the best job of which it is capable.

The results of the study indicate that the first effect is generally the more serious; force requirements depend with particular sensitivity on the aiming-error distribution. This is illustrated in Table 10,

which indicates the number s of attacks needed to insure a probability of success equal to 0.90, when the standard error of aim, σ_a , is 100 ft and 200 ft, respectively. This table is based on the best spacing in each case. An overestimate of σ_a may be less serious (and an underestimate more serious) than

TABLE 11. Efficiency of attack when σ_a is mis-estimated, judged by ratio of probabilities of at least k hits. Target 1×6 , $\theta = 0^\circ$, $\sigma_d = 0.25$.

		True σ_a 200				100			
		Assumed 100				200			
k	n	1	2	4	8	1	2	4	8
	1		1.00	0.98	0.97	0.95	1.00	1.00	0.99
2		0.75	1.00	1.00	0.97	0.71	1.00	1.00	1.00
3		0.59	0.71	0.97	1.00	0.63	0.68	1.00	1.00
4		0.50	0.67	0.94	1.00	0.58	0.68	0.80	1.00
5		0.12	0.58	0.76	1.00	0.56	0.58	0.68	1.00

suggested by the table, for the mis-estimate will probably be accompanied by the use of other-than-optimum spacing, which will diminish (or enhance) the apparent difference.

The effect of mis-estimate on the execution of the mission is less pronounced, for here one is not concerned with the difference between what can be accomplished with one value of σ_a (or σ_d) and another value of σ_a (or σ_d), but only with the difference between what can be accomplished when it is and is not recognized that σ_a (or σ_d) has a certain

TABLE 12. Efficiency of attack when σ_d is mis-estimated, judged by ratio of probabilities of at least k hits. Target 1×6 , $\theta = 90^\circ$, $\sigma_a = 2$.

		True σ_d 0.3			0		
		Assumed 0			0.3		
k	n	1	2	4	1	2	4
	1		1.00	0.96	0.99	1.00	0.97
2		1.00	1.00	1.00	1.00	1.00	1.00
3		1.00	1.00	1.00	1.00	1.00	1.00
4		1.00	1.00	1.00	1.00	1.00	1.00
5		1.00	1.00	1.00	1.00	1.00	1.00

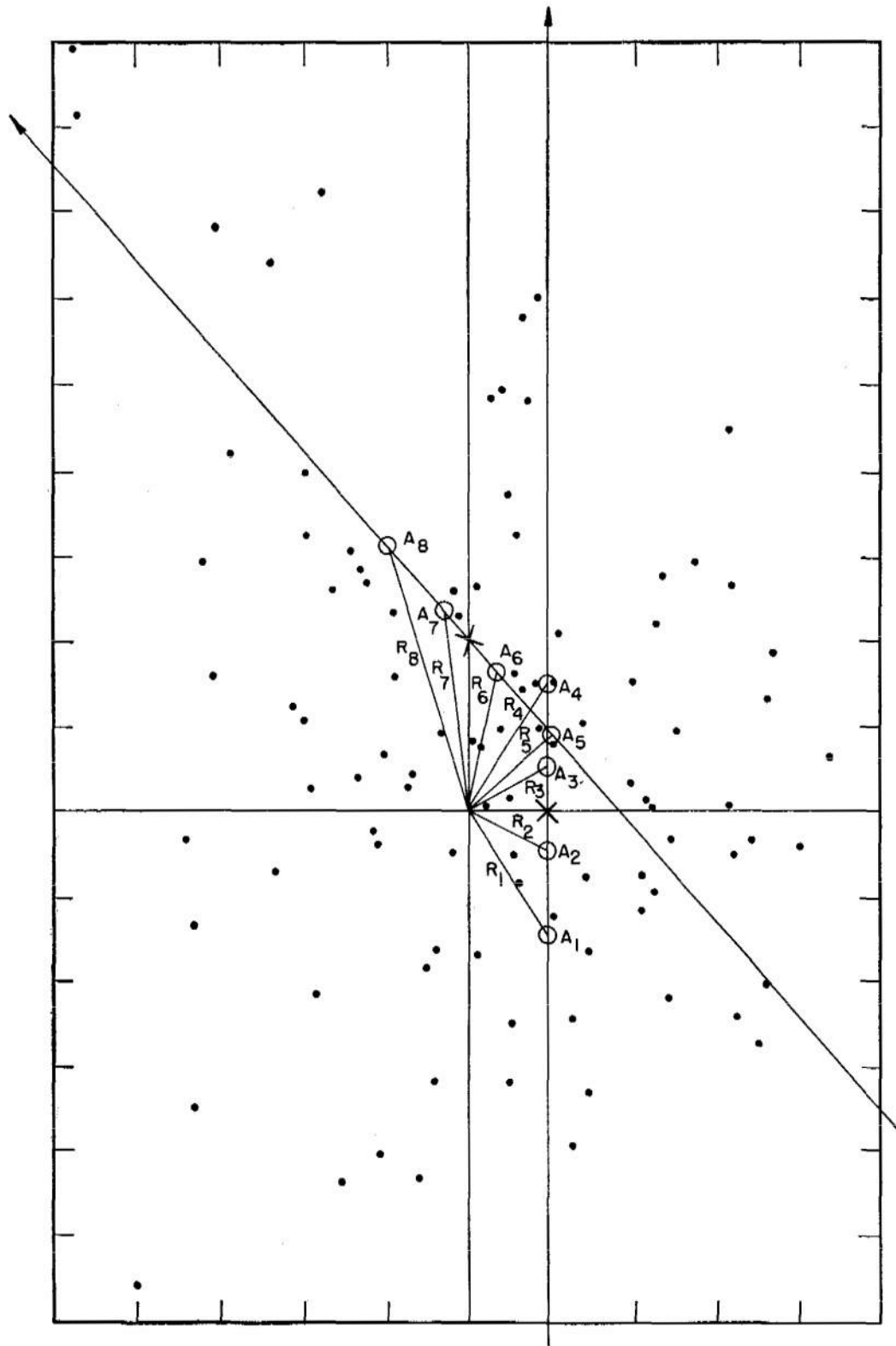

FIGURE 13. Synthetic bomb plot illustrating technique for measuring standard deviation of aiming errors from post-raid photograph.

value. Mis-information regarding σ_a (or σ_d) will cause one to use an incorrect spacing, but as observed earlier, the curves P_k versus I are generally so flat-topped that substantial departures from the optimum \hat{I} do not necessarily imply substantial changes in P_k . Illustrative cases are exhibited in Tables 11 and 12.

4. *Combat data.* A method of estimating combat aiming errors, applicable if the bomb plot is not biased, is given here. If each of s aircraft independently aims a train of n bombs and if a post-raid photograph shows some of the craters, say N , an estimate may be made of σ_a , the one-dimensional standard deviation of the aiming-error distribution, provided it can be assumed that the aiming-error distribution is circularly symmetric and that the parameter σ_d specifying the bomb-dispersion distribution is known. In fact, σ_a may be estimated from

$$\sigma_a^2 = \frac{1}{2}(\bar{r}^2 - \bar{R}^2) - \sigma_d^2, \quad (12)$$

where the symbols r and R are defined as follows: Choose an origin O near the center of the observed bomb fall; measure the distance, R_i , from O to A_i , the *intended* point of impact for the i th bomb; measure also the distance r_i from O to a_i , the *actual* point of impact of the i th observed crater. Then

$$\bar{R}^2 = \frac{\sum_{i=1}^{ns} R_i^2}{ns} \quad (13)$$

and

$$\bar{r}^2 = \frac{\sum_{i=1}^N r_i^2}{N} \quad (14)$$

(ns is the number of bombs dropped and N is the number of craters counted).

The situation is illustrated in Figure 13 which shows $N = 100$ craters selected at random from $ns = 4 \times 100$ bombs dropped by two waves of 50 aircraft, each aircraft carrying four bombs. The aiming points for the bombs in train are designated by A_1, A_2, A_3, A_4 for one wave, and by A_5, A_6, A_7, A_8 for the other. The plot was synthesized from a certain train-bombing experiment performed at Eglin Field. In this case equation (12) gave $\sigma_a = 217$ ft compared to the value 224 ft when all the data were used in the most efficient manner.

The details of the material here are contained in a number of AMP papers.^{1,17,18,19}

3.7 APPLICATIONS OF RECTANGULAR TARGET THEORY

The present section comprises reviews of several specific applications of train-bombing theory, applications both to high- and to low-altitude bombing.

The principal distinction between high- and low-altitude bombing, from the point of view of theory, is that in one case the target may be regarded as a planar region and in the other it usually may not, for at low altitudes the bomb trajectories at impact depart from the vertical to such an extent that the three-dimensional character of the target often cannot be neglected.

Another distinction, which frequently occurs when the Norden and Sperry synchronous bombsights are used, concerns the aiming-error distribution. This is almost a circular Gaussian at high altitudes, whereas at low altitudes the range component greatly exceeds the deflection component.

Purpose of the Study. The purpose of this investigation was to study the effect of rectangular target theory on four types of targets.

1. *Bridges.* To determine the probability P_1 of at least one hit and the best spacing \hat{I} in high-altitude attacks on bridge or viaduct-like targets.

2. *Ships: Hitting.* To determine the spacing best suited to produce at least one hit in low-altitude radar-sighting attacks on shipping targets.

3. *Ships: Sinking.* To determine the probability of *sinking*, as opposed to *hitting*, in attacks on shipping targets.

4. *Minefields.* To determine the number of bombers (light, medium, or heavy) which must attack a minefield in order that the probability of clearing a proportion F of a path shall be 0.5 or 0.9.

Method of Analysis. The analysis was done separately for each of the four categories.

1. *Bridges.* The basic tables for the probabilities of at least one hit are extended so as to provide information on $1 \times 6, 1 \times 9, 1 \times 13, 1 \times 20, 1 \times 30, 1 \times \infty$ targets. Nomograms are constructed from which the probability P_1 and the best spacing \hat{I} can be read for any high-altitude attack, on the assumption that $\sigma_a = 34$ mils ($CEP = 40$ mils) and $\sigma_d = 4$ mils.

2. *Ships: Hitting.* The best spacings \hat{I} to produce at least one hit are explored in the basic train-bombing tables, and then suitably averaged. Account is taken of the altitudes, aircraft speeds, aiming-error distributions, bomb ricochet, and ship types

all the nomograms, to the case $\sigma_a = 34$ mils, $\sigma_d = 4$ mils. To use it one places the index arrow of the detachable *altitude scale* against the horizontal *target-width scale*. Then, at the appropriate altitude mark, one erects a perpendicular which intersects the curves

are contained in a simple rule-of-thumb for bomb spacing, stated in Table 13. The probability of hitting when this rule is used is something like 25 per cent greater than when a spacing equal to target width is used.

TABLE 13. Rule-of-thumb for bomb spacing \hat{I} in APQ-5 attacks on shipping targets.

Bombing from a	Using as spacing the ship's beam multiplied by
PBY	2.1
PBM	2.3
PB4Y or PBJ	2.6
PV2	3.1

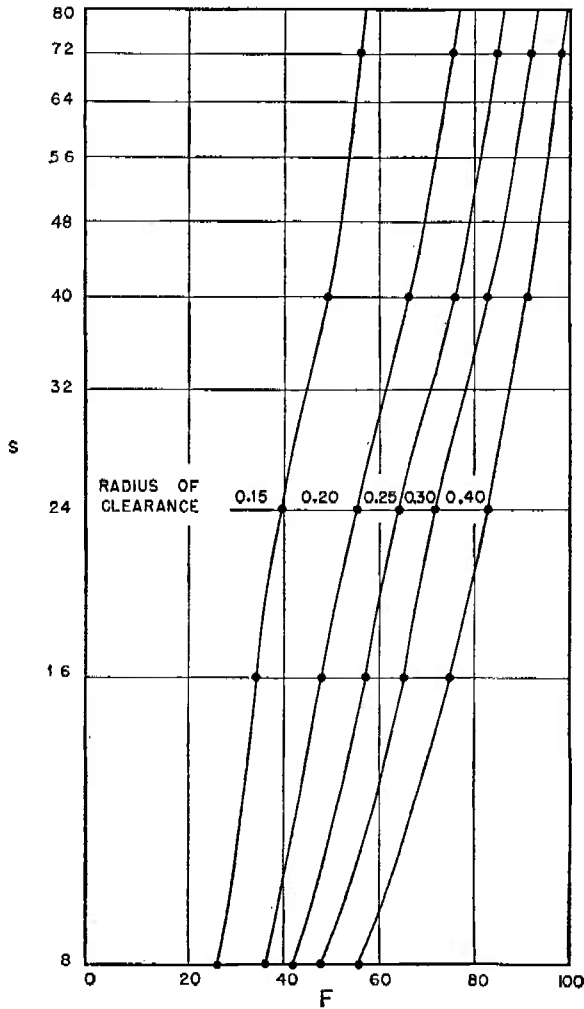

FIGURE 15. Percentage clearance F of best path through minefield vs number s of attacks by medium bombers needed to give 50 per cent confidence in result. Target $6 \times \infty$, $\theta = 90^\circ$, $\sigma_a = 6$, $\sigma_d = 0.3$, $I = 0.3$, $n = 6$, width of path = 0.3.

corresponding to various target ratios, 1×6 , 1×9 , etc. Opposite the appropriate intersection, on the vertical scale, one reads P_1 , the probability of at least one hit with a single train of 8 bombs. The numbers along the curves are the ratios of bomb spacing to altitude. An auxiliary table²⁰ gives P_{1s} , the probability of at least 1 hit with s trains, given P_1 .

2. *Ships: Hitting.* The results for low-altitude attacks (< 800 ft) using the APQ-5 radar bombsight

3. *Ships: Sinking.* The principal conclusion regarding ship-sinking probabilities is that the best spacing of bombs in train is somewhat smaller than \hat{I} required to maximize the probability \hat{P}_1 of at least one hit. While no general rule has been discovered, it appears that the best spacing usually lies in the range $\frac{3}{4} \hat{I}$ to \hat{I} . In view of the tendency for P versus I curves to be relatively flat-topped, the spacing \hat{I} which maximizes the probability of at least one hit often nearly maximizes the probability of sinking.

4. *Minefields.* The principal results are given in graphs like Figure 15. Here, for given conditions regarding the aiming-error and bomb-dispersion distributions, the number of bombs in train, aircraft type, width of path and of minefield, there is a plot of proportion F of clearance along best path versus number of aircraft, with radius of clearance as the family parameter.

The study includes similar results for pattern bombing.

Full discussions of these studies are contained in several AMP documents.^{20,21,22,23,24}

3.8 SCATTER-BOMBING THEORY

The process of releasing a number of bombs simultaneously from approximately the same position in space is sometimes called *scatter bombing*. This is, in a sense, a transition stage between train bombing and pattern bombing, for it may be regarded as train bombing in which the spacing I is zero, or it may be regarded as pattern bombing in which the dimensions of the formation of aircraft (the usual implement in pattern bombing) are negligible compared to the pattern dimensions.

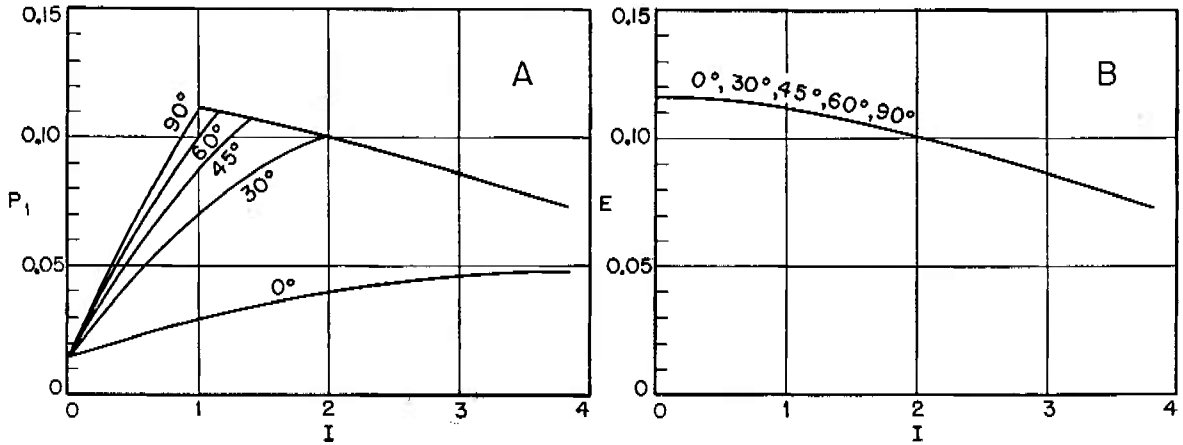

FIGURE 16. Probability P_1 of at least one hit (graph A) and expected number E of hits (graph B) vs spacing I of bombs in train, for various values of θ , the angle of attack. Target 1×6 , $\sigma_a = 8$, $\sigma_d = 0$, $n = 8$.

The theory presented below usually presupposes a quite limited number of bombs and always presupposes a circular-Gaussian distribution, characterized by σ_d , about the center of each cluster. Since these conditions are met more frequently in the case

and since it has been demonstrated that the optimum spacing \hat{I} which maximizes the probability P_k of at least k hits is not in general zero, the question may be asked: Why is there interest in scatter bombing? The answer is twofold: (1) It is not always possible to capitalize fully on the potentialities of train bombing, as when small bombs are released from a cluster. (2) It is not always desirable to do so, for scatter bombing maximizes the expected number of hits, or the long-term average number, say E .

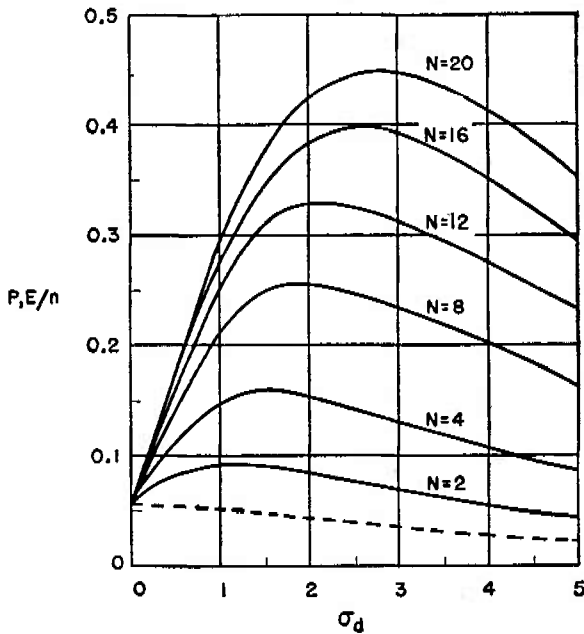

FIGURE 17. Probability P_1 of at least one hit and expected number E/n of hits per bombs vs standard deviation σ_d of bomb dispersion, for values of n , the number of bombs in salvo. E/n given by broken line. Target 1×6 , $\sigma_a = 4$.

of single aircraft, we have preferred to discuss scatter bombing in the present chapter on train bombing, rather than in Chapter 4, which is devoted to pattern bombing.

Since scatter bombing may be viewed as the limiting case of train bombing, in which the spacing $I = 0$,

The last point may be demonstrated by reference to Figure 16 where the graph A illustrates the familiar dependence of P_1 on I and θ (the discontinuities in the derivatives are characteristic of the special case where bomb dispersion σ_d is zero), and graph B shows the dependence of the expected number E of hits on I and θ ; E does not depend on the angle of attack and it attains its greatest value when $I = 0$.

Purpose of the Study. The purpose of the study is to provide basic values of the probability P_1 of at least one hit and of the expected number E of hits for rectangular and circular targets under conditions of scatter bombing.

Method of Analysis. The method of analysis is again that of formal probabilities. In fact, for the rectangular targets, equations (1) through (3) suffice if the spacing I is set equal to zero.

For circular targets the formulas may be written

$$P_1 = 1 - \frac{1}{\sigma_d^2} \int_0^\infty e^{-x^2/2\sigma_d^2} q^n x dx, \quad (17)$$

where

$$q = q\left(\frac{R}{\sigma_d}, \frac{x}{\sigma_a}\right) = \frac{1}{2\pi\sigma_d^2} \int_R^\infty \int_0^{2\pi} e^{(-1/2\sigma_d^2)(\rho^2 + x^2 - 2\rho x \cos \theta)} \rho d\theta d\rho. \quad (18)$$

Here, R is the radius of the target and n the number of bombs, and σ_a and σ_d are the standard deviations which characterize the circular-Gaussian distributions of the aiming errors and of bomb dispersion, respectively.

Extensive tables of q have been prepared in the course of the work and a number of approximate formulas have been developed.

Results. The principal results of the study are presented in the form of graphs. Figure 17 is a typical

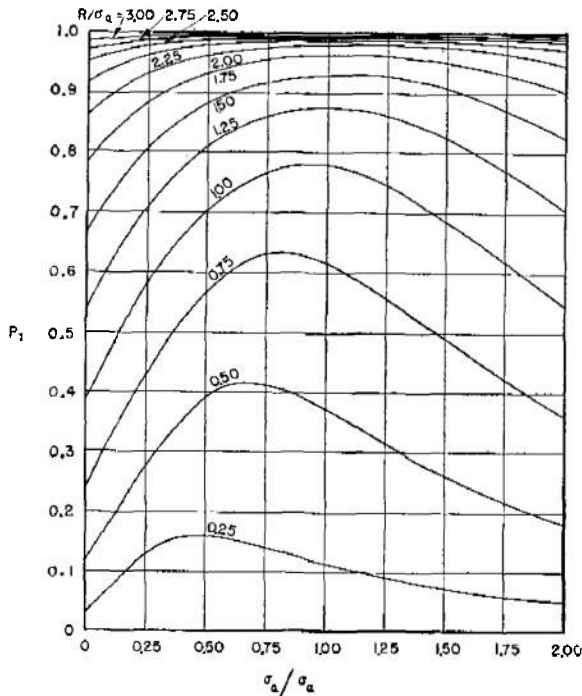

FIGURE 18. Scatter-bombing attack: Probability P_1 of at least one hit vs ratio, σ_d/σ_a , of standard deviations of bomb dispersion and aiming errors, for various values of R/σ_a ; $n = 8$.

example of the rectangular-target results, where the values of P_1 and of E are shown by solid and broken lines, respectively. It should be noted that E/n , rather than E , is plotted; the reasons for this choice being that E/n is invariant with respect to n and that this quantity may be plotted on a zero-to-one scale, as if it were a probability.

It will be observed that, in a certain sense, the bomb dispersion, σ_d , plays a role in scatter bombing analogous to the spacing I in train bombing. The spacing related to σ_d is, superficially, more of a statistical affair than is I , which is usually—and erroneously—thought of as a strictly geometrical effect. As in the case already discussed for I , there is an optimum value of σ_d , say $\hat{\sigma}_d$.

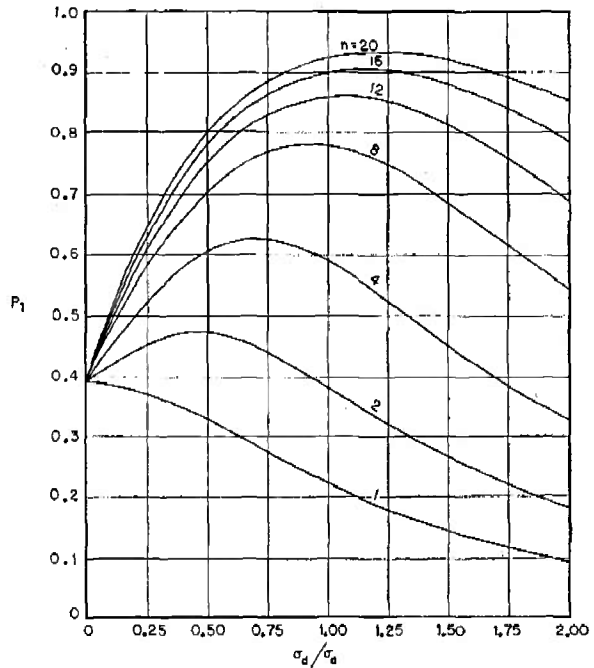

FIGURE 19. Scatter-bombing attack: Probability P_1 of at least one hit vs ratio, σ_d/σ_a , of standard deviations of bomb dispersion and aiming errors, for various values of n , the number of bombs in salvo; $R = \sigma_a$.

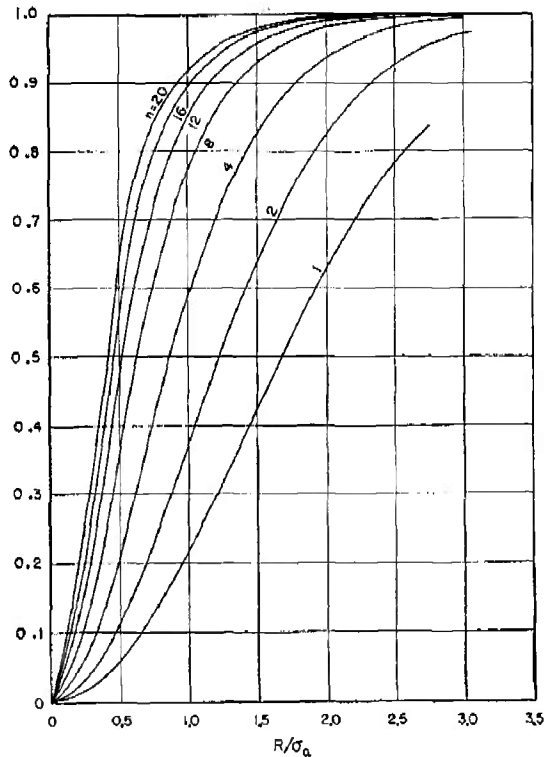

FIGURE 20. Scatter-bombing attack: Probability P_1 of at least one hit vs ratio, R/σ_a , of target radius to standard deviations of aiming errors, for various values of n , the number of bombs in salvo; $\sigma_d = \sigma_a$.

Calculations for the rectangular targets have been made for the following conditions: targets 1×1 , 1×3 , 1×6 , 1×9 ; $\sigma_a = 1,248$ (and 16 for 1×9 target); $n = 2, 4, 8, 12, 16, 20$.

The results for the circular targets are presented in

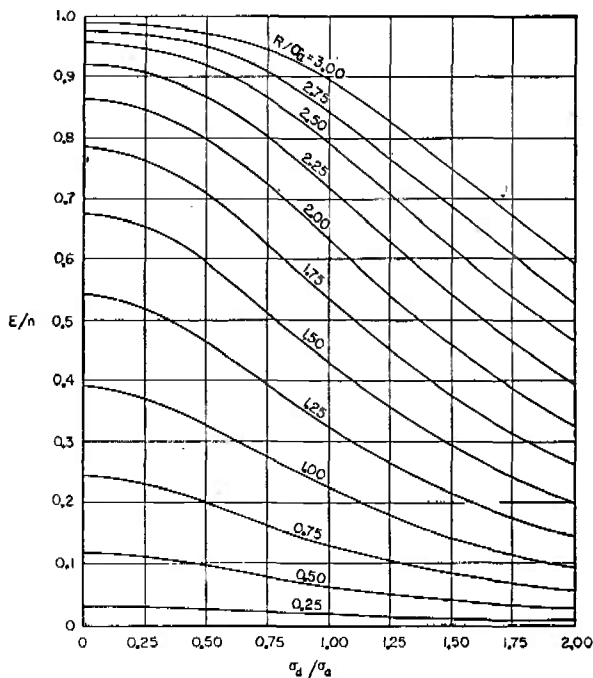

FIGURE 21. Scatter-bombing attack: Expected number E/n of hits per bomb vs ratio, σ_d/σ_a , of standard deviations of bomb dispersion and aiming errors, for various values of R/σ_a .

several sets of charts, Figures 18, 19, and 20 being typical examples of each. All sets are based on the same data, the various sets having been compiled as a convenience to the user, who may find that one or another set is best suited to his needs.

Figure 18 shows P_1 versus σ_d/σ_a , with R/σ_a as a family parameter; Figure 19 uses n as the family parameter. Figure 20 shows P_1 versus R/σ_a , with n as the family parameter. The ranges of the variables covered are 1 to 20 for n , $1/4$ to 3 for R , 0 to 2 for σ_d (the last two are in units of σ_a).

Figure 21 shows E/n versus σ_d/σ_a , with R/σ_a as the family parameter. This chart, thanks to the invariance of E/n with respect to n , displays all the results, concerning expected number of hits, calculated for circular targets.

Figure 22 is a special chart for the optimum dispersion, $\hat{\sigma}_d$, optimum with reference to the maximum probability \hat{P}_1 of at least one hit (the optimum value of σ_d is 0 with reference to E). Here is shown $\hat{\sigma}_d/\sigma_a$ versus R/σ_a , with n as the family parameter.

The theory and results outlined above are reported more fully in AMP publications.^{25,26,27}

3.9 APPLICATIONS OF SCATTER-BOMBING THEORY

Very few applications of the scatter-bombing theory discussed above have appeared in bombing operations during the course of World War II; for although bombs have frequently been dropped in clusters, e.g., the small incendiaries, these have almost invariably been employed as trains of clusters, or as patterns of clusters.

The theory has had applications, however, in the field of aerial gunnery and in the field of naval gunnery. As a matter of fact, the computations described in Section 3.8 were undertaken at the request of the Bureau of Ordnance.

The applications to bombing described below, namely air-to-air and guided-missile bombing, are somewhat special. In fact, they derive only minor assistance from the calculations reported above.

Purposes of the Studies. The purposes of the studies are:

1. *Air-to-air.* To obtain a rough estimate of P_1 where a single B-29, or a four-aircraft diamond of

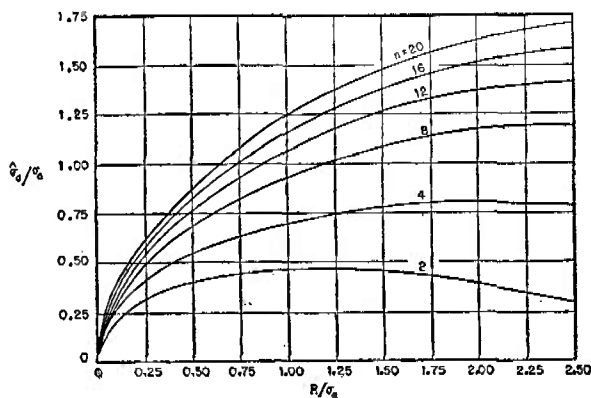

FIGURE 22. Scatter-bombing attack: Ratio, $\hat{\sigma}_d/\sigma_a$, of standard deviations of optimum bomb dispersion to aiming errors vs R/σ_a , for various values of n , the number of bombs in salvo.

B-29's, is attacked with a 50-bomb cluster, percussion fuzed.

2. *Guided missiles.* To obtain a rough estimate of P_1 when a long narrow target is attacked with several AZON (a missile whose position in deflection may be modified by remote control), released simultaneously from a single aircraft.

Method of Analysis. The analysis was done in terms of air-to-air and guided-missile bombing.

1. *Air-to-air.* The target area in the case of a B-29, or a diamond formation of B-29's, is extremely complicated compared to the simple rectangles and circles considered above. Therefore, no direct use may be made of the probabilities so far calculated. However, the latter can be made to yield a hint regarding the magnitude of the optimum dispersion, $\hat{\sigma}_d$.

Using an estimated value of σ_d and a table of random numbers, a pattern of 50 bombs is constructed. For the aiming-error distribution of interest (a circular Gaussian with components), σ_a , a sample of n aiming errors is constructed, again using a random-number table. The sample bomb pattern is now centered in turn at each of the aiming-error points, which are marked on a map of the target, and at each position of the pattern one observes

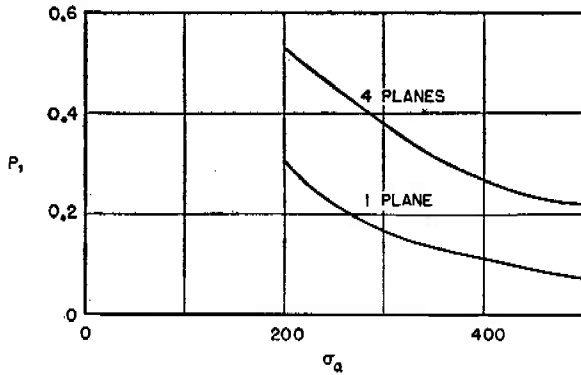

FIGURE 23. Probability P_1 of at least one hit vs standard deviation σ_a of aiming errors, for scatter-bombing attack on one B-29 and on a four-ship diamond of B-29's. Attack made with 50 percussion-fuzed bombs having approximately optimum dispersion. Diamond formation assumed to be 200 ft wide between centers; aircraft flying nose-to-tail.

whether or not there is a hit. The success ratio in a series of trials is an estimate of P_1 , i.e., $H/n \rightarrow P_1$, where H is the number of trials which yielded hits.

2. *Guided missiles.* The estimation of P_1 for a salvo of AZON is relatively easy under the circumstances postulated here. Several AZON, say n , are released simultaneously from an aircraft flying parallel to a long target and then controlled by a bombardier using a single control box; all AZON receive the same signals. Thus, the operator may guide the centroid of the cluster to a desired position, or he may attend to any particular member of the cluster,

but he cannot reduce the inherent scatter in deflection, measured by σ_d . Assume that he chooses a bomb at random and guides it to the line target. The aiming errors associated with this operation are measured by σ_a . It is an experimentally determined fact that $\sigma_a \ll \sigma_d$. Under these conditions the probability of at least one hit is approximately

$$P_1 = 1 - [1 - p(\sigma_a)] [1 - p(\sqrt{2}\sigma_d)]^{n-1}, \quad (19)$$

where $p(\sigma)$ is the probability of hitting with a single AZON when the standard error of aim is σ . The factor, $\sqrt{2}$, arises because we are now interested in the distribution of the cluster about an arbitrary member of the cluster, rather than in the distribution about its natural center.

Results. The principal results are given in tables and charts.

1. *Air-to-air.* The results of the study are summed up in a single graph, Figure 23, where the probability P_1 of at least one hit is plotted against the standard deviation σ_a of the aiming errors.

It appears that, with even a moderately good solution to the aiming problem, this tactic constitutes a real threat to bombardment aircraft. However, the probability for hitting can probably be diminished greatly if the target has any freedom for maneuver.

2. *Guided missiles.* Table 14 shows the result of three calculations based on equation (19). Experi-

TABLE 14. Probability P_1 of at least one hit with salvo of six AZON. For one AZON, $P_1 = 0.26$; for six independent attacks, $P_{16} = 0.84$. Target = $0.2 \times \infty$, $\sigma_a = 0.3$.

$\sqrt{2} \sigma_d$	P_1
100	0.51
200	0.40
400	0.33

mental data suggest that $\sqrt{2}\sigma_d$ is of the order of 300-400 ft.

Since the cost of bombs is a small part (a few per cent) of the overall cost of a bombing mission, it is definitely worth while to carry and use a full load of AZON even on single-bombing-run missions.

The work on air-to-air bombing is more fully described here than in the SRG-P working paper,²⁸ which is the only written record. The AZON work is discussed in an AMP report.²⁹



Chapter 4

PATTERN BOMBING

4.1

INTRODUCTION

THE PRINCIPAL bombing tactic used by the United States medium heavy and very heavy bombers in World War II employed the almost simultaneous release of all the bombs carried by a formation of aircraft, thus giving rise to a pattern of bombs affected, as a unit, by an aiming error. This pattern is the fundamental unit in terms of which such bombing is discussed.

The Army Air Forces developed this tactic to a surprisingly high state of efficiency in visual operations, considering the inherently difficult coordination requirements and the instrumental limitations. The ultimate in this kind of bombing would be represented by the ability to lay a pattern of the size wanted at the place wanted. The first requires precision flying by all pilots and prompt release by all bombardiers. (The radio-release operating from the lead aircraft was used in the last year of the war, but rarely even then.) The second requires a bombsight capable of accurately aiming a pattern, rather than a single bomb, and of aiming it at a target offset, if necessary, from a good aiming point. The radar operations, of course, have even greater need for such a bombsight.

Early in the war the bombing studies of AMP were, as the result of stimulus from the Army Air Forces, largely devoted to train bombing. As the war progressed and the Army Air Forces developed the art of pattern bombing, AMP, after some lag due to insufficient information from the Services as well as to a desire to finish the train-bombing work at hand, shifted the emphasis in its work to pattern bombing. By the time the war ended AMP's efforts, being devoted to the various kinds of bombing, bore a reasonable relationship to the relative frequencies of these forms in combat.

4.2 AVERAGE PROPORTION OF HITS WITH UNIFORM PATTERNS

The most common criterion of success in pattern bombing is the expected proportion, or long-term average proportion, of hits. Reference to scatter-bombing theory shows that this criterion is maximized by making the pattern as small as possible. It

is evident that one would become dissatisfied with this method of measuring success if the patterns were made very small, for it would then attach a premium to over-bombing. Probably a better criterion would be the proportion of target elements hit, but to capitalize on this concept would require tailoring the pattern to the target, a process which would have been very difficult with Army Air Force equipment of World War II vintage.

Purposes of the Study. The purposes of the study were to calculate the expected proportion $E(H)$ of hits and the standard deviation σ_H of the proportion for various values of the pattern dimensions and mean radial error *MRE* (or circular probable error *CEP* or standard deviation of aiming error, σ_a).

Method of Analysis. The mathematical model is that of a rectangular target, $l_T \times w_T$, and a uniform rectangular bomb pattern, $l_P \times w_P$, with the sides of the latter parallel to those of the former. The center of the pattern is subject to a Gaussian distribution of errors with its mean at the target center.

The expected proportion of hits is

$$E(H) = \frac{M_l M_w}{l_P w_P} \left[P(L_1) - P(L_2) \right] \left[P(W_1) - P(W_2) \right] \quad (1)$$

and the variance is

$$\sigma_H^2 = E(H^2) - E^2(H), \quad (2)$$

where

$$E(H^2) = \left(\frac{M_l M_w}{l_P w_P} \right)^2 \left[S(L_1) - S(L_2) - \frac{2l}{M_l} P(L_2) \right] \left[S(W_1) - S(W_2) - \frac{2w}{M_w} P(W_2) \right]. \quad (3)$$

The parameters so far undefined are identified below.

$$M = k \sigma_a$$

$$L_1, L_2 = \left| \frac{l_P \pm l_T}{M_l} \right|; \quad W_1, W_2 = \left| \frac{w_P \pm w_T}{M_w} \right| \quad (4)$$

$$l = \min(l_P, l_T); \quad w = \min(w_P, w_T).$$

The functions $P(x)$ and $S(x)$ are defined as follows when $k = 1$ (i.e., $M = \sigma_a$):

$$P(x) = \frac{x}{2}G\left(\frac{x}{2}\right) + 2G'\left(\frac{x}{2}\right), \tag{5}$$

$$S(x) = 2\left[1 + \left(\frac{x}{2}\right)^2\right]G\left(\frac{x}{2}\right) + xG'\left(\frac{x}{2}\right),$$

where

$$G(x) = \frac{1}{\sqrt{2\pi}} \int_0^x e^{-\frac{1}{2}t^2} dt, \tag{6}$$

$$G'(x) = \frac{1}{\sqrt{2\pi}} e^{-\frac{1}{2}x^2}.$$

Results. The functions, $P(x)$ and $S(x)$, in terms of which $E(H)$ and σ_H are expressed, have been tabulated by AMP for use with σ_a ($k = 1$), MRE ($k = 1.2533$), and CEP ($k = 1.1772$). Two or three Army research groups have independently tabulated either $P(x)$ or $E(H)$, for the one-dimensional case. Graphs and tables are available for $G(x)$ and $G'(x)$.

A nomogram for $E(H)$ is shown in Figure 1. While ostensibly designed for use exclusively for square patterns and square targets, it may be applied to rectangular patterns and rectangular targets by entering first with the lengths, say, then with the widths. The desired answer is the geometric mean of the two values of $E(H)$ so found, i.e., the square root of the product of the two values of $E(H)$. Errors as great as about 12 per cent have been observed in the nomogram, but generally the error is about 5 per cent.

Contour diagrams for $E(H)$, of the type shown in Figure 2, are available for square targets, rectangular patterns, and equal and unequal components of aiming error, σ_{ar} and σ_{ad} . The latter charts are of value in assessing pattern bombing with the controlled missile, AZON.

The graph in Figure 3 provides estimates of σ_H , but only for square patterns and square targets.

The tables and graphs referred to and more detailed presentation of the theory may be found in several AMP documents.^{1,2,3,4}

4.3 PROBABILITY DISTRIBUTION OF THE PROPORTION OF HITS WITH UNIFORM PATTERNS

The expected proportion, $E(H)$, of hits and the standard deviation, σ_H , calculated in the preceding study, do not tell the whole story. For example, one may wish to know the probability that at least a

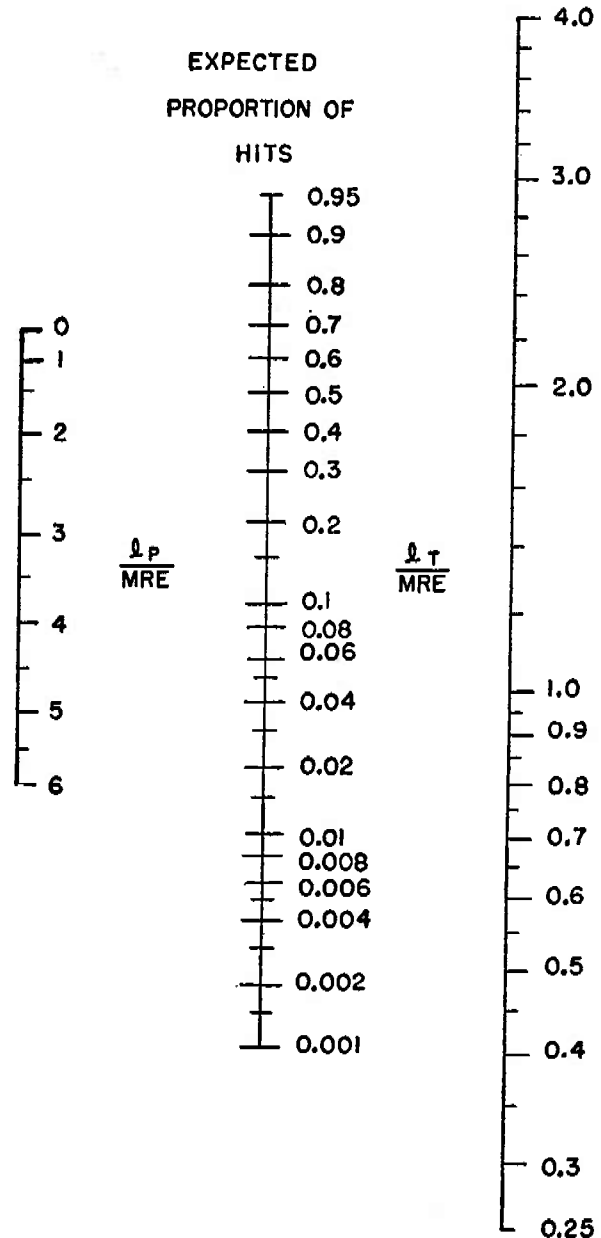

FIGURE 1. Nomogram for estimating the expected proportion of hits when square patterns (side = l_P/MRE) are released against square targets (side = l_T/MRE).

given proportion of hits, H , will occur, when H is assigned at pleasure. It was with this thought in mind that this study was undertaken.

Purpose of the Study. The purpose of the study was to compute the probability that the proportion of hits in a single attack with a uniform pattern would be at least (or at most) any assigned value H . These computations were done for those rectangular targets and square patterns specified by the Army group which initiated the study.

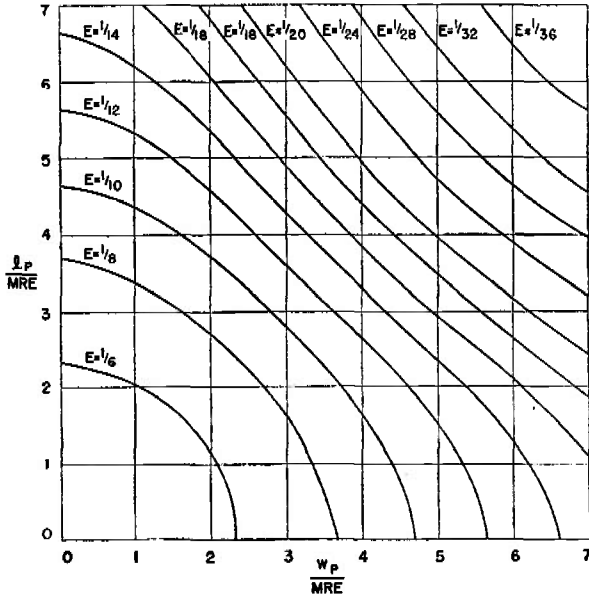

FIGURE 2. Contours for constant values of the expected proportion E , i.e., $E(H)$, of hits for rectangular patterns ($l_p/MRE \times w_p/MRE$) and square targets ($l_T/MRE = w_T/MRE = 1$).

Method of Analysis. There is a locus for pattern center in the target plane, say $\phi(R, \theta) = 0$ in polar coordinates, such that the proportion of hits is exactly H . The probability $P(H)$ that the proportion of hits will be at least H is found by numerical inte-

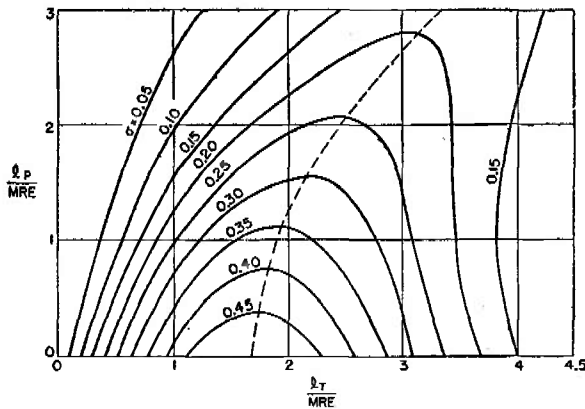

FIGURE 3. Contours for constant values of the standard deviation σ_H of the proportion of hits, for square patterns (side = l_p/MRE) and square targets (side = l_T/MRE).

gration within this contour which leads to the following formula:

$$P(H) = \frac{2\Delta\theta}{\pi} \sum_i (1 - e^{-R_i^2/2\sigma^2}). \quad (7)$$

Here $\Delta\theta$ is the interval in θ over which R is treated as a constant and R_i is the value of R corresponding to the i th value in the set of θ 's.

Simpler formulas apply in certain cases.

Results. The results were presented in charts of the form shown in Figure 4. Several values read from the curves, together with the expected proportion

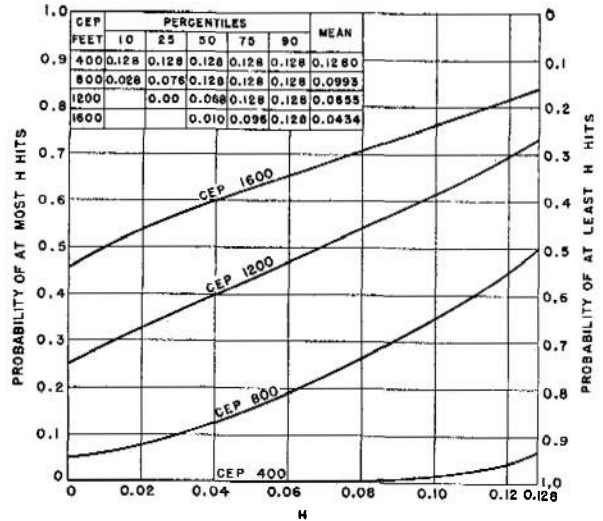

FIGURE 4. Probability that in a single formation attack the proportion of hits will be at most (or at least) H . Square pattern of area 5×10^6 sq ft and target 800×800 ft.

$E(H)$ of hits, were collected in a small table associated with each graph. Calculations have been extended to the sets of conditions which are itemized in Table 1.

Sets of tables and graphs and a full discussion of the theory are contained in a report⁵ by AMP.

1.4 PROBABILITY DISTRIBUTION OF THE PROPORTION OF COVERAGE WITH UNIFORM PATTERNS

The preceding study was concerned with the proportion of the *pattern* which falls on the target, the common criterion of success in World War II in bombing with high explosives. The present study was concerned with the proportion of the *target* covered by patterns, a subject which comes to the fore in toxic-gas bombing, or in bombing with any other area-covering weapon.

Purpose of the Study. The purpose of the study was to estimate the number of attacks, with specified aiming-error distributions and patterns, needed to give a probability of at least P that at least the proportion F of the target would be covered at least m times.

Method of Analysis. The method of analysis consisted of a model experiment in which a series of synthetic random-bombing operations were performed, with enough replications to permit the estimation of probability levels from order statistics. The data, so

met most of the theoretical conditions, it is not safe to apply the formula indiscriminately outside the observed range.

Results. The principal result of the study is the following rather formidable formula:

TABLE 1. Values of the parameters used in the study of the distribution of the proportion of hits, for uniform patterns. All 480 combinations of the values of the parameters were considered.

Targets		Square patterns (area)	CEP's
1 × 1	1 × 3	25	4
2 × 2	1 × 5	50	8
4 × 4	2 × 5	100	12
8 × 8	2 × 10	150	16
16 × 16	2 × 50	300	
		500	
		750	

$$s = \frac{4F}{5p^2} \cdot \frac{-5 \log(1-P) + (m-1)(2+5P)}{Fe^{-A_1} + P(1+2P)te^{-A_2}} \cdot e^{-(m-1)A_3} + 2(m-1)^{\frac{1}{3}} e^{-\frac{1}{5}t^2}, \quad (8)$$

where

$$A_1 = \frac{3}{2}t + \frac{10}{3}\left(F - \frac{1}{2}\right)\sqrt{t}, \quad (9)$$

$$A_2 = \frac{2}{5}P + F - \frac{1}{2} + \frac{7}{8}t, \quad (10)$$

$$A_3 = 5\left(\frac{2}{3} - P\right)e^{-\frac{3}{5}m} + \frac{11}{4m}\left(F - \frac{2}{3}\right) + \left\{\frac{3}{80}(2F-1)t[8(1-F)t^2 - 5(9-5F)t + 20(4-3F)] + \frac{2}{5}(22P^2 - 23P + 5) + \frac{5P + 14}{15,000}(4t-9)^4\right\} e^{4-2m-\sqrt{t}}. \quad (11)$$

accumulated, was then used as the basis for an empirical function whose general properties were suggested by theoretical considerations.

This work was brought to a hurried conclusion at the end of the war. The empirical formula obtained

Here p, t = side of pattern and target expressed in terms of the mean radial error MRE as unit,

F = least proportion of target covered, on the average,

m = number of times the fraction F of the target is covered,

P = least probability that the least coverage is F , and m -fold,

s = number of patterns required in order that the probability will be at least P that the m -fold coverage is at least F .

Sets of charts, of which Figure 6 is typical, are available. In these, equation (8) is mapped for almost all values of the arguments used in deriving it, and, consequently, for values of the arguments for which it can be guaranteed to produce good values of s . These values are:

$$F = 0.2, 0.5, 0.8$$

$$P = 0.2, 0.5, 0.8$$

$$m = 1, 2, 3, 4$$

$$t = 1, 2, 3, 4 \text{ (and 0 when } m = 1\text{)}.$$

The charts referred to, a detailed discussion of the theory, and all of the original data are contained in an AMP memorandum.⁶

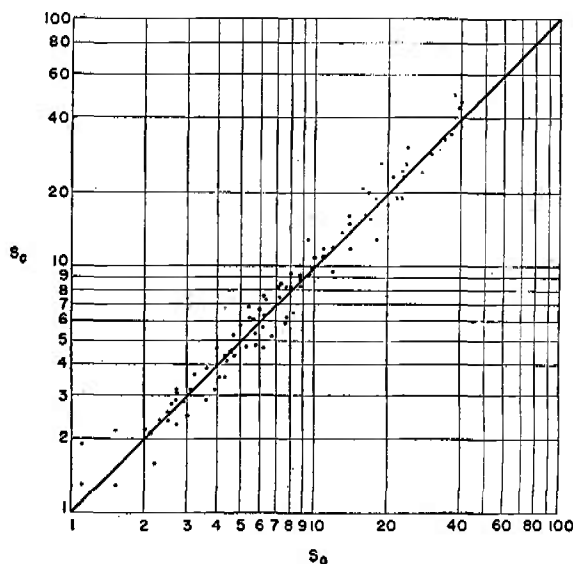

FIGURE 5. Typical scatter-chart showing computed, s_c , vs observed, s_o , values of s , the number of attacks needed to make the probability at least P that the proportion of m -fold coverage will be at least F .

met most of the theoretical conditions of adequacy, though it did not satisfy all of them, and fitted the data satisfactorily, as evidenced by the typical sample of observed versus computed values plotted in Figure 5. Because the empirical formula fails to

1.5 STATISTICALLY UNIFORM PATTERNS

In the preceding sections it has been assumed that the bomb pattern is a perfectly uniform area. In this study the assumption was modified; it was recognized that a pattern consists of a certain number N of bombs each having a radius R of effectiveness, and it was assumed that they constituted a sample from a statistically uniform distribution.

Purpose of the Study. The purpose of the study was to estimate the probability P'_{ks} that in s attacks there

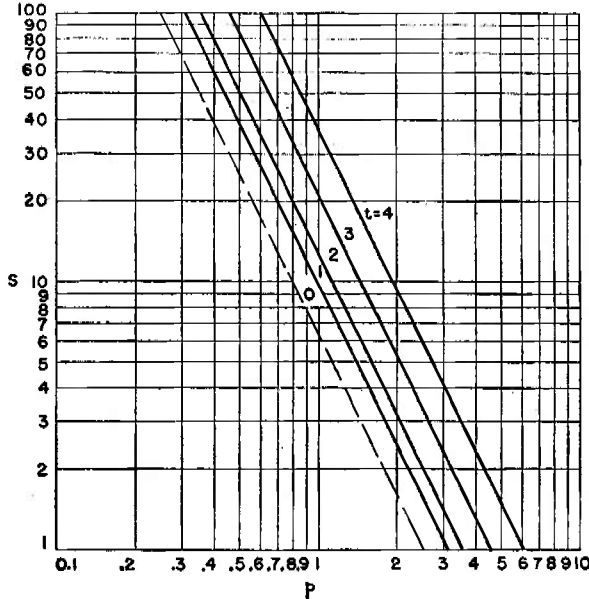

FIGURE 6. Chart of number s of attacks vs side p of square pattern needed to make the probability at least $P = 0.8$ that the proportion of single coverage will be at least 0.8, for square targets of side t ; all lengths are measured in terms of the mean radial aiming error MRE as unit.

would be exactly k hits (1) on a sub-target of radius R , or (2) on a point sub-target by bombs of effective radius R . Items (1) and (2) are alternative statements of the same mathematical problem.

Method of Analysis. The method of analysis is that of formal probability theory. The probability P'_{ks} of making exactly k hits in s attacks on a target at the point (x,y) , may be written

$$P'_{ks} = \frac{1}{k!} \left[\frac{d^k}{dZ^k} \left(\sum_{i=0}^N P'_{i1} Z^i \right)^s \right]_{Z=0} \quad (12)$$

where, for small values of R ,

$$P'_{i1} = \left[G \left(\frac{x + \frac{W}{2}}{\sigma_{ad}} \right) - G \left(\frac{x - \frac{W}{2}}{\sigma_{ad}} \right) \right]^i$$

$$\left[G \left(\frac{y + \frac{L}{2}}{\sigma_{ar}} \right) - G \left(\frac{y - \frac{L}{2}}{\sigma_{ar}} \right) \right]^i \cdot \frac{e^{-D} D^i}{i!},$$

$$D = \frac{N\pi R^2}{LW}; \quad (13)$$

G is given by equation (6).

Perhaps the quantity

$$P_{1s} = 1 - P'_{0s}, \quad (14)$$

the probability of at least one hit, is of greatest interest.

Results. The formulas of the preceding paragraphs were applied to the problem of finding the optimum pattern dimensions, \bar{L} and \bar{W} (measured in terms of σ_a , standard deviation of the aiming-error distribution), for a knock-out attack on a target comprising many important sub-targets. The criterion is that the probability defined in equation (14) of the destruction of a sub-target [at one corner (x',y') of the target area] be large. A nomogram is provided⁷ for the estimation of \bar{L} and \bar{W} .

Similar formulas were applied to the problem of determining the pattern, $L^* \times W^*$ (measured in

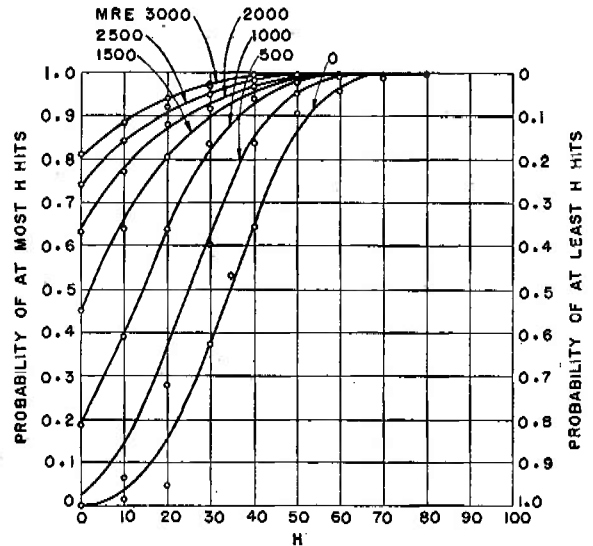

FIGURE 7. Graph showing the probability that the proportion of hits will be at most (or at least) H plotted against H . For single attacks ($s = 1$); for operational patterns of area 3×10^6 sq ft and circular target of radius 500 ft. Circles indicate observed points.

terms of σ_a , standard deviation of aiming-error distribution), which is optimum in the sense that it maximizes the expected number of sub-targets which may be hit in a single attack on a target area comprising many uniformly distributed sub-targets. A

nomogram is provided for the estimation of L^* and W^* .

This work is discussed at length in two AMP papers^{4,7} prepared by the Statistical Laboratory of the University of California.

4.6 DEPENDENCE OF PROPORTION OF HITS ON PATTERN AREA AND MRE AS DETERMINED BY OPERATIONAL PATTERNS

In the studies of the preceding sections attempts have been made to set up simple working models which would serve as satisfactory bases for pattern bombing theory. Comparisons between theory and practice indicate that even the simplest model is often quite successful.

However, there are certain difficulties in the way of bringing theory and practice into complete accord, simply because the physical situation is much more complex than a tractable, simple model. The present study sought to overcome some of these difficulties by letting data from a large number of past operations tell their own story, assisted very little by theory.

Purpose of the Study. The purpose of the study was to determine the probability distribution of the proportion H of hits, for specified values of the mean radial error (Gaussian distribution) and pattern area, on the basis of operational reports regarding the observed proportion of hits, pattern area, and individual values of aiming error. In this study one must watch carefully in order to distinguish between mean radial (aiming) error and aiming error; the distinction is crucial to an understanding.

TABLE 2. Percentiles of at most (at least) the proportion H of hits, the expected proportion $E(H)$ of hits, and the standard deviation σ_H of the proportion of hits for operational pattern of area 3×10^6 sq ft and circular target of radius 500 ft.

Number of attacks	MRE feet	Percentiles of at most H hits					$E(H)$	σ_H	
		10	25	50	75	90			
1	0	0.17	0.25	0.35	0.44	0.52	0.35	0.14	
	500	0.07	0.15	0.25	0.35	0.44	0.25	0.14	
	1,000	0.00	0.03	0.14	0.25	0.36	0.16	0.15	
	1,500		0.00	0.02	0.15	0.30	0.09	0.13	
	2,000			0.00	0.07	0.24	0.06	0.12	
	2,500				0.00	0.18	0.04	0.10	
	3,000					0.12	0.03	0.08	
2	0	0.22	0.28	0.35	0.41	0.47	0.35	0.10	
	500	0.13	0.18	0.26	0.32	0.39	0.25	0.10	
	1,000	0.03	0.09	0.16	0.23	0.30	0.16	0.11	
	1,500	0.00	0.01	0.07	0.16	0.23	0.09	0.09	
	2,000		0.00	0.02	0.11	0.19	0.06	0.08	
	2,500			0.00	0.07	0.15	0.04	0.07	
	3,000				0.04	0.11	0.03	0.06	
3	0	0.26	0.30	0.35	0.39	0.43	0.35	0.07	
	500	0.16	0.21	0.25	0.30	0.34	0.25	0.07	
	1,000	0.07	0.11	0.16	0.21	0.25	0.16	0.08	
	1,500	0.01	0.04	0.08	0.13	0.18	0.09	0.06	
	2,000	0.00	0.01	0.05	0.09	0.14	0.06	0.06	
	2,500		0.00	0.02	0.07	0.11	0.04	0.05	
	3,000			0.01	0.05	0.08	0.03	0.04	
			90	75	50	25	10		
			Percentiles of at least H hits						

Method of Analysis. In single attacks ($s = 1$) with the pattern, the target, and the aiming-error distribution all specified, the probability that the proportion of hits will equal or exceed the fraction H may be written as the Stieltjes integral

$$P(H) = 1 - \int_{-\infty}^{\infty} G\left(\frac{H}{r}\right) dQ(r). \quad (15)$$

Here

$$Q(r) = \int_0^r \frac{x}{\sigma_a^2} e^{-x^2/2\sigma_a^2} dx \quad (16)$$

and $G(H/r)$ is the probability that, given a specific value of the aiming error r the proportion of hits will be less than H . $G(H/r)$ is determined exclusively from the data.

Similar formulas are developed and evaluated for $s = 2$ and $s = 3$ attacks, and approximations for use with higher values of s are explained.

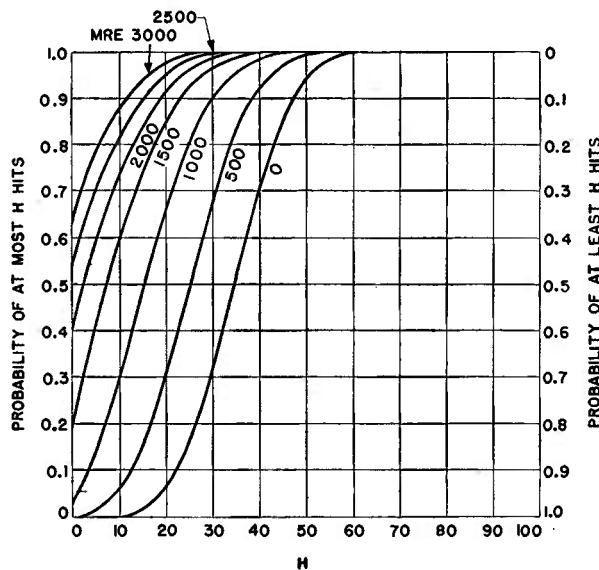

FIGURE 8. Graph showing the probability that the proportion of hits will be at most (or at least) H plotted against H . For double attacks ($s = 2$); for operational patterns of area 3×10^6 sq ft and circular target of radius 500 ft.

Results. The principal results are displayed in a set of tables and charts, of which Table 2 and Figures 7, 8, and 9 are typical. From these can be read the answers to almost any problem involving the proportion of hits in pattern bombing.

The tables and charts referred to above, and a detailed discussion of the procedure, appear in a report⁸ by AMP.

4.7 DEPENDENCE OF PATTERN AREA AND MRE ON OPERATING FACTORS AS DETERMINED BY OPERATIONAL PATTERNS

The preceding study went a long way toward establishing quantitatively the relationship between proportion of hits on the one hand and the pattern area and MRE on the other, but it did not indicate

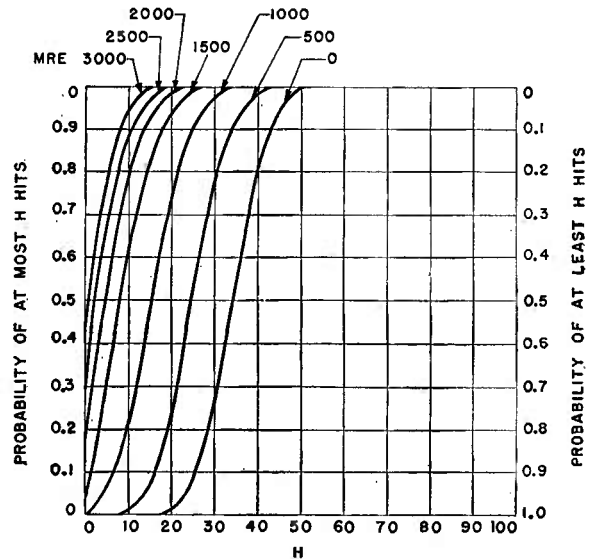

FIGURE 9. Graph showing the probability that the proportion of hits will be at most (or at least) H plotted against H . For quadruple attacks ($s = 4$); for operational patterns of area 3×10^6 sq ft and circular area of radius 500 ft.

the roles played by operating factors. In the present study that was attempted.

Purpose of the Study. The purpose of the study was to discover quantitative relationships between pattern statistics (length, width, area, etc.) and mean radial error on the one hand, and various operating factors (altitude, aircraft type, numbers of bombs and aircraft, etc.) on the other.

Method of Analysis. Regression equations were set up and solved using all of the suitable data compiled during the last year's operations of the Eighth Air Force in ETO.

Results. The principal results of the study are a series of regression equations. The coefficients in the regressions for various pattern statistics are given in equations (17) to (24) displayed in Table 3, and a regression for mean radial aiming error follows:

$$\log_{10}(MRE) = 0.514 + 0.0118T + 0.00573A + 0.278 \log_{10}(100LW) - 0.0672B_1 + 0.161B_2 + 0.0200B_3 + 0.00747B + 0.364f(t). \quad (25)$$

TABLE 3. Regression equations for various pattern statistics, based on operational patterns.

Equation	Regression	Coefficients of											Remarks
		<i>I</i>	<i>T</i>	<i>N</i> ₉	<i>N</i> ₁₂	<i>N</i> ₁₈	<i>A</i>	<i>N</i> _b	$(N_b-1)^{\frac{1}{4}}$	<i>t</i>	<i>t</i> ²	$t \cos \frac{\pi}{2}(t-4)$	
(17)	$\log_{10} \left(\frac{LW}{100} \right)$	0.0432		-0.455	-0.325	-0.164	0.0229	0.00670		0.0515	-0.00287		B-17's
(18)	$\log_{10} \left(\frac{LW}{100} \right)$	-0.0225		-0.342	-0.224		0.0278	0.00576		0.0604	-0.00409		B-24's
(19)	$\log_{10} \left(\frac{LW}{100} \right)$		0.122	-0.459	-0.295	-0.167	0.0242		0.216	-0.00656		-0.00633	B-17's, B-24's
(20)	$\log_{10} L$		0.059	0.668	0.733	0.788	0.0143		0.155	-0.00355		-0.00227	B-17's, B-24's
(21)	$\log_{10} W$		0.060	0.876	0.975	1.048	0.0098		0.061	-0.00314		-0.00402	B-17's, B-24's
(22)	$\log_{10} \left(\frac{L^*W^*}{100} \right)$		0.139	-0.761	-0.590	-0.402	0.0259		0.192	-0.0118		-0.00148	B-17's, B-24's
(23)	$\log_{10} L^*$		0.077	0.481	0.560	0.645	0.0153		0.158	-0.0070		0.00070	B-17's, B-24's
(24)	$\log_{10} W^*$		0.058	0.761	0.850	0.953	0.0105		0.035	-0.0048		-0.00218	B-17's, B-24's

In these equations the symbols have the following meanings: *L*, *W*, *L**, *W** are pattern length and width expressed in hundreds of feet, measured according to two criteria: *L*, *W* are measurements which include

is expressed in millions of square feet. *I* = 0 or 1 for salvo or minimum intervalometers. *T* = 0 or 1 for B-17 or B-24. *N*₉, *N*₁₂, *N*₁₈ = (1,0,0), (0,1,0), or (0,0,1) according as the formation is standard for 9, 12, or 18 aircraft. *A* = altitude in thousands of feet. *N*_b = number of bombs per aircraft. *B*₁, *B*₂, *B*₃ = (1,0,0), (0,1,0), (0,0,1) or (0,0,0) according as the order-over-target is 1, 2, 3 or > 3, while *B* is order-over-target without qualification over the range 1 ≤ *B* ≤ 9; *t* = months, beginning with April 1944 where *t* = 4; and *f*(*t*) is an arbitrary function of *t* to which seven values were assigned, based on graphs of the data.

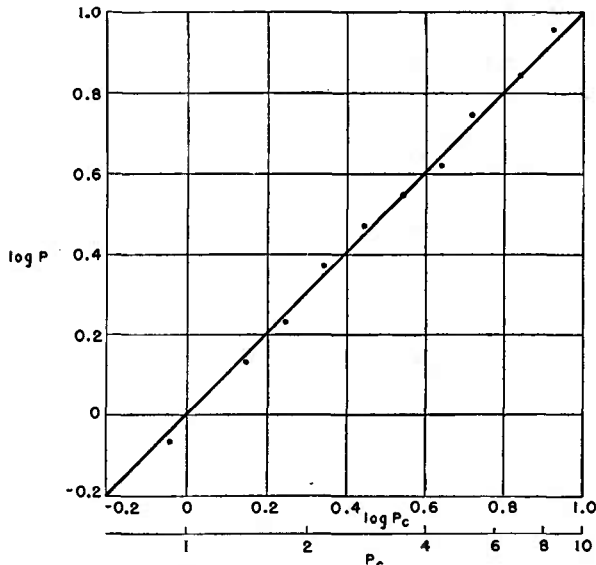

FIGURE 10. Graph showing the relationship between observed average values of $\log P$ and values of $\log P_c$, i.e., $\log_{10} (LW/100)$, computed from the regression equation (19).

Some notion regarding the goodness of fit of the equations to the data may be gained from Figures 10 and 11, where the observed values of pattern area and *MRE* are compared with those computed from equation (19) and equation (25).

It is not practicable to discuss the results adequately here. The reader is referred to an AMP paper⁹ for a full discussion. The data used are included therein.

roughly 90 per cent of all bombs in the pattern; *L**, *W** include 80 per cent of the bombs in range and 80 per cent in deflection, independently. *MRE* is expressed in hundreds of feet. Pattern area (*LW*/100)

4.8 PRACTICE PATTERNS WITH CONTROLLED MISSILES

The preceding studies of operational patterns were not based directly on the actual patterns, but on certain measurements made on those patterns. In a relatively few instances it has been possible to make

a detailed, accurate bomb plot of actual patterns, both in combat and in practice bombing. Several studies of these were in progress, but were abandoned, at the end of the war. However, the following small and highly specialized study was one of this type completed by AMP.

Purpose of the Study. The purpose of the study was to estimate the probability that the proportion of

respond to standard bombs, AZON excluding failures, and AZON including failures.

The method and results are given in full in a report^{2a} by AMP.

4.9 SYNTHETIC PATTERNS FOR CLEARANCE OF MINEFIELDS

A few studies have been carried out in which an attempt was made to synthesize patterns by putting together a geometrical array of trains, sometimes taking into account the variations in spacing between aircraft, in release times, etc. Some work of this kind has been done analytically, but it seems that when it is considered as a standard method for analyzing bombing problems, the rewards are not great enough to compensate for the labor. It has, however, served usefully as a verification of the approximate adequacy of simpler theory, such as that of statistically uniform patterns.

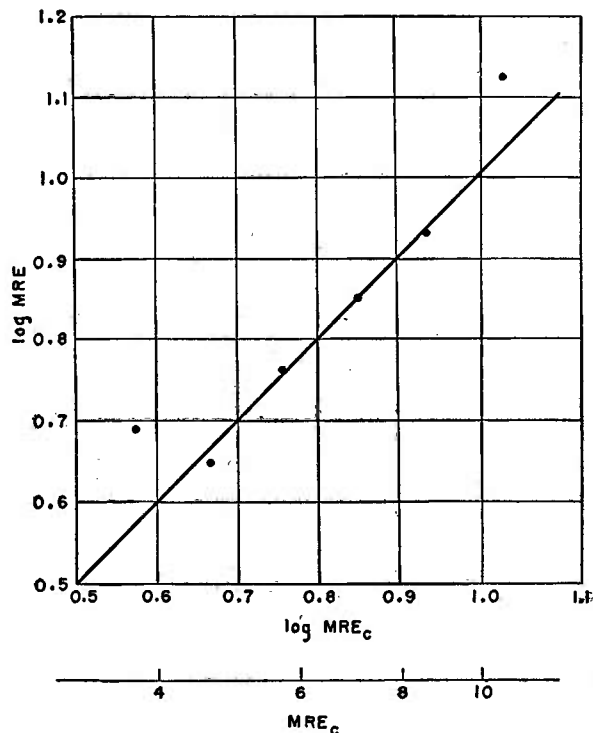

FIGURE 11. Graph showing the relationship between observed average values of $\log_{10} MRE$ and values of $\log_{10} MRE_c$ computed from the regression equation (25).

hits would exceed H , if the bombing were done in formation and with the controlled missile AZON.

Method of Analysis. Practice patterns of AZON and others of standard bombs were used in a model experiment. The pattern plots were dropped (figuratively) some hundreds of times at points determined by a table of random deviates from a Gaussian distribution. It was assumed that the standard bombs were affected by an error distribution in which $MRE = 600$ feet and that the AZON patterns were similarly affected but that the deflection component of the error was reduced effectively to zero.

Results. The results are displayed in a series of graphs of which Figure 12 is a typical example. Here the probability $P(H)$ that the proportion of hits will exceed H is plotted against H . The three curves cor-

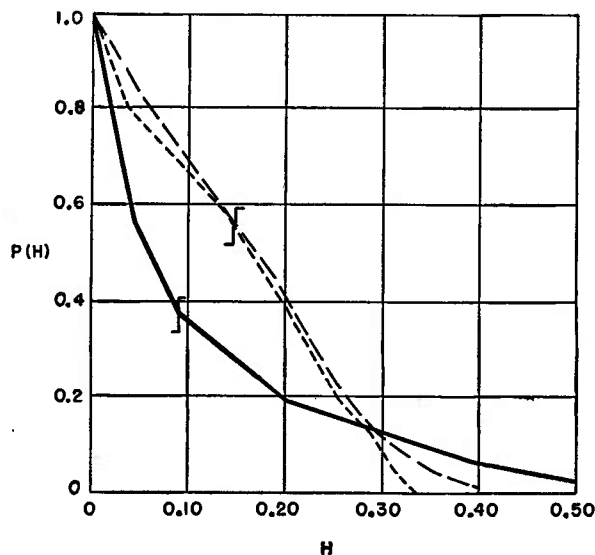

FIGURE 12. Probability $P(H)$ that the proportion of hits will be at least H vs the proportion H of hits, for standard bombs (solid), AZON excluding failures (broken), and AZON including failures (dotted); for attacks on circular target of radius 250 ft, from an altitude of 15,000 ft, with a 30-bomb pattern dropped by a formation of eight aircraft. $MRE = 600$ ft normally, but $\sigma_{nd} = 0$ for AZON. Vertical bars indicate positions of the means.

In the following studies such problems were solved by statistical experiments, or by graphical methods. They are discussed briefly here because of their value in bombing research. The methods are given in greater detail in Chapter 7.

Purpose of the Study. The purpose of the study was to determine the number of heavy-bomber formations which must attack a minefield in order that the probability of clearing a proportion F of a path be 0.5 or 0.9.

Inspections to determine the proportion F of clearance achieved along the best path; the radius of clearance, depending both on mine and bomb, is involved in this calculation. The complete experiment was replicated 30 times for each set of conditions.

Results. The principal results are displayed in graphs of which Figure 13 is typical. Here, for given conditions (aiming-error and bomb-dispersion distributions, number of bombs in train, width of path and of minefield) there is given a plot of proportion F of clearance along the best path versus number of aircraft, with radius of clearance as the family parameter.

The study includes similar results for train bombing. A full discussion of this problem appears in an AMP report.¹⁰

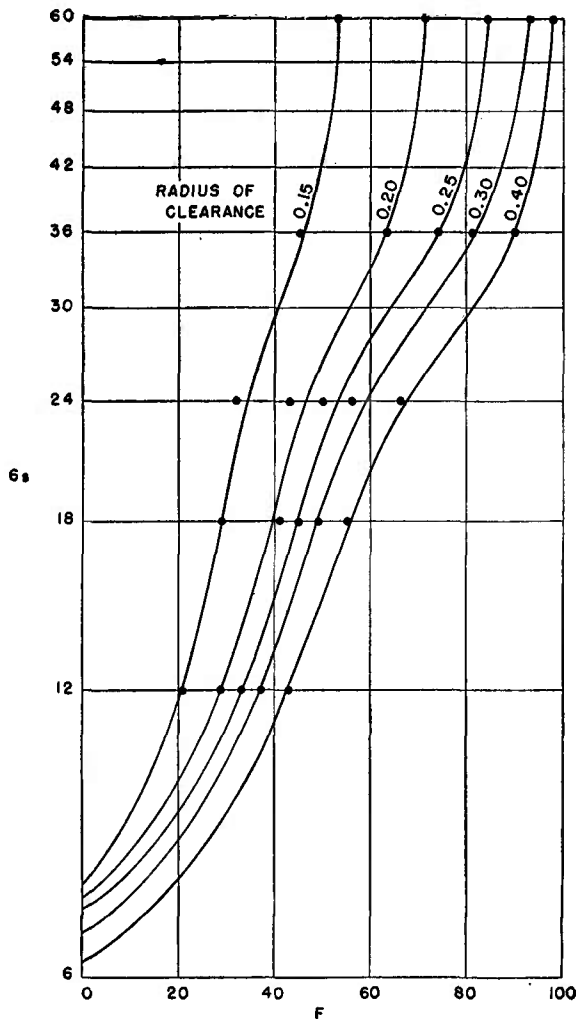

FIGURE 13. Number, $6s$, of aircraft attacks with 6-aircraft heavy-bomber formations vs proportion F of best path cleared. Probability, $P = 0.9$, that clearance is at least F . Minefield $6 \times \infty$, $\sigma_a = 6$, $\sigma_d = 0.3$, $I = 0.3$, path width = 0.3, $n = 12$. Dispersion of the train components of the pattern measured by $\sigma_t = 3.4$.

Method of Analysis. The problem was solved using a model experiment. Fifty synthetic train stencils (incorporating bomb dispersion) were prepared. A set of six stencils, selected at random, was placed on a map of the minefield in such a manner that the center of the set would fall on a mark indicating an aiming error drawn from a known Gaussian distribution. The process was continued, with periodic in-

4.10 SYNTHETIC PATTERNS FOR A MANEUVERING TARGET

So far as we know, no really satisfying analysis has been made of formation attacks against maneuvering targets. The following study, which is simply exploratory, relates to the secondary activity of anti-submarine patrol bombers, which must be prepared to congregate and mount attacks on enemy surface ships.

Purpose of the Study. The purpose of the study was to discover the spacing of aircraft and bombs and the direction of attack which will maximize the probability P_1 of at least one hit on a small warship; the attack being delivered by a small formation comprising five or six aircraft, each carrying eight bombs.

Method of Analysis. The standard deviations of the aiming-error distribution were assumed to be four and five times the target width; since a ship with beam of 50 ft is large for this problem, the standard deviations, σ_a , are not greater than 200–250 ft. These values were chosen early in the war before more realistic (larger) estimates came to hand.

The analysis was largely graphical and controlled by the following minimax principle: There is some course of action, i.e., maneuver, open to the target which, for any specified form of the attack, will minimize the probability of at least one hit. That attack is judged to be best which maximizes this minimum probability. This is illustrated in Figure 14 where the probability P_1 is plotted against a scale showing possible positions of a destroyer 30 sec after a decision to maneuver— A and A' correspond to hard left and right turns, B to no turn. The spacing I referred to

on the curves is the lateral spacing between aircraft. According to the criterion adopted, the curve for spacing $I = 4W$ identifies the best tactic shown

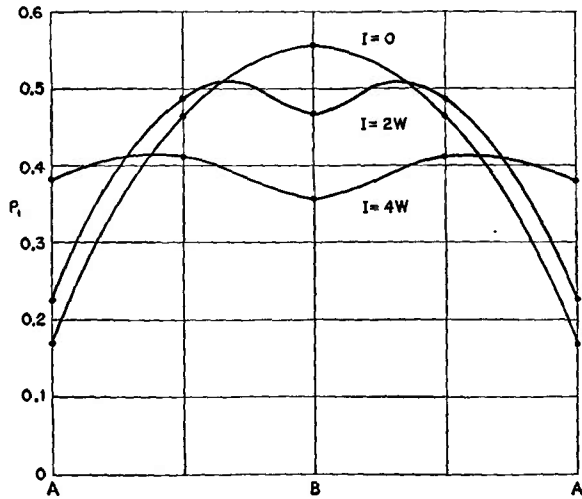

FIGURE 14. Probability P_i of hitting a maneuvering target, in a fore-and-aft attack by a 5-aircraft formation with lateral spacing I between aircraft, vs possible target positions. B corresponds to target remaining on original course, A (or A') to a hard left (or right) turn.

because the lowest point on this curve is higher than the lowest point on the others.

Results. Perhaps the principal results of the study are qualitative. For example, it seems quite clear that some types of attack are very much better than others, and that it is a reasonable undertaking to

isolate the better ones. Also, that even in problems such as this one, where the enemy has a great deal of choice in the matter of defensive countermeasures, attacks can be designed in which the probability of success is very stable and depends little on the countermeasures.

In the present case, the best attack discovered was a beam attack, with lateral spacing of twice target width between aircraft, each aircraft (in effect) aiming in range so as to place its train center on the theoretical locus of possible ship position; spacing in train is taken as $1.5W$.

The work is discussed at length in a report¹¹ of the AMP.

4.11 PHOTOELECTRIC ANALYSER FOR SYNTHETIC PATTERNS

Throughout this volume—indeed as recently as the study in Section 4.9—the reader will have encountered the model experiment, used as a means to solve certain bombing problems which would proceed tediously if approached by numerical integration. The present study concerns a device which mechanizes the work of a model experiment.

Purpose of the Study. The purpose of the study was to design an instrument, the *Photoelectric Analyser*, which, by mechanizing the procedures of a model experiment, would quickly estimate the probability of at least one hit or, alternatively, the expected proportion of hits, in formation attacks on irregular target areas.

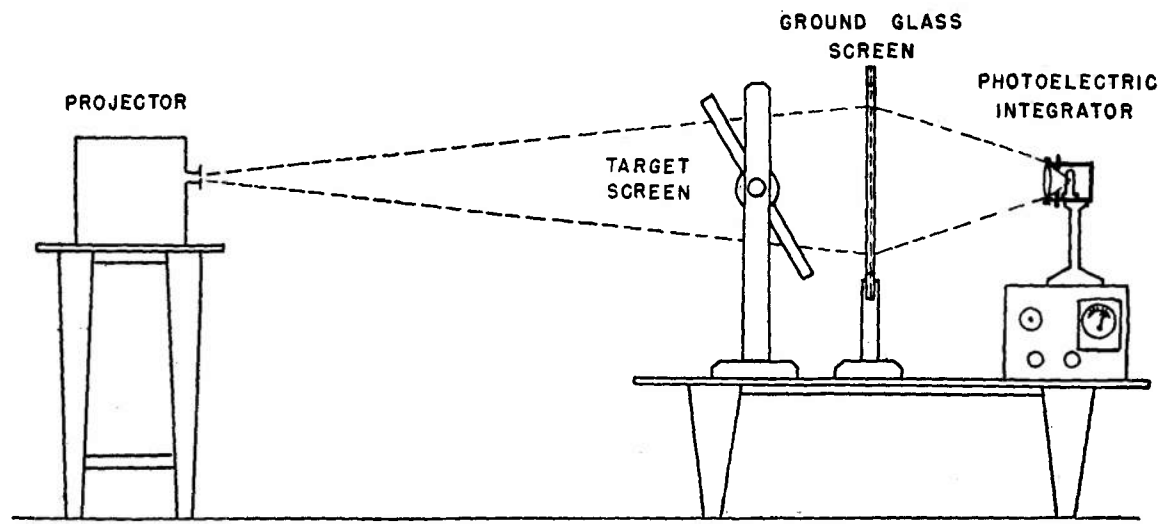

FIGURE 15. Diagram of *Photoelectric Analyser*. The principal function of the instrument is to estimate the proportion of hits on an irregular target.

Method of Analysis. The method of analysis was to measure, with a photoelectric receiver, the light from a ground-glass screen which is illuminated as follows. A white image, on a black background, of a synthetic bomb pattern was projected on the ground glass after passing through a diaphragm-stop cut out in the form of the target. Thus the screen was only illuminated by an image of that part of the bomb pattern which intersected the target. The light from the screen was focused on a photoelectric cell which was instrumented so as (1) to add the effect of successive images of bomb patterns, or (2) to count the cases which were not blank. A movie projector and a film with 1,500 frames were used. Each frame carried a

picture of the bomb pattern with its center displayed to represent a random deviate from a Gaussian distribution.

Results. The study has resulted in the design and construction of a simple photoelectric device which vastly expedites the estimation of the expected proportion of hits, as well as the probability of at least one hit, on irregular target areas. The photoelectric device is shown diagrammatically in Figure 15.

The construction and use of the photoelectric analyzer is discussed in detail in a document¹² written by one of AMP groups.

Shortly before the war ended it was planned to construct several of these instruments at Wright Field.

Chapter 5

FURTHER INVESTIGATIONS

5.1

INTRODUCTION

THE PRESENT chapter comprises investigations which, for one reason or another, do not seem to fit neatly into the classification adopted for determining the contents of the preceding chapters. This is evidence that the classification has its weaknesses, and in no way reflects on the importance of the studies discussed here, relative to those discussed in earlier chapters.

As an example of this difficulty, consider the study *Incendiary Bomb Attacks on German Targets* discussed in Section 5.5. It is concerned with incendiary attacks on German targets and draws its information from American and British attacks which featured, respectively, formation bombing, in which all the aircraft of a group released on the leader, and train bombing, in which each aircraft sighted independently. Thus, the study cuts squarely across the fundamental classification. Further, one of the principal objects of the study is to determine the vulnerability characteristic of fire divisions. So far as it is concerned with target vulnerability, the study is almost unique in AMP bombing work. For these reasons its review has been deferred to the present chapter.

The first few studies discussed immediately below relate to problems in which the mathematical model used for calculation is not necessarily a conscious idealization of one or another specific operational, or tactical, technique, that is, they are not offered as solutions to problems in which the tactics have been specified. Rather, the spirit of the approach is this: Here is a geometrical model which obviously bears a relationship to problems, or parts of problems, sometimes met in bombing investigations. Any time the tactics being considered promise to give rise to approximately this geometrical situation, and, further, when the probability statements made in connection with the situation are germane to the problem at hand, the results of the study may be applied. It is perhaps unnecessary to add that this kind of study is often one in which the mathematical work proceeds quite smoothly, or in which the results can be presented concisely, for these often constitute the motivation for the model. It should not be inferred that the studies under discussion did not arise in response

to specific problems, for they did; but the geometry of a military problem can sometimes be discussed before the tactics are selected.

5.2 CONDITIONAL PROBABILITY OF MISSING AT MOST r SECTIONS OUT OF n SPECIFIED SECTIONS FOR STATISTICALLY UNIFORM DISTRIBUTIONS

The present study was one of the first by AMP to be aimed at the problems of saturation bombing and the clearance of minefields by aerial bombardment. It provides the answers to several questions which, while not the most important ones in very many bombing situations, throw some light on several important problems.

The underlying assumption on which the study is based is that bombs are distributed over a region, called the *target area*, in the random manner associated with the term *statistical uniformity*, i.e., if the target area is subdivided into specific sections or cells of equal area, each bomb is as likely to fall in one section as in another. A variation of this statement, useful on occasion, is that with almost any distribution one may subdivide the target area into sections having equal probability of being hit, instead of into sections having equal area, without affecting the mathematical formulation.

Purpose of the Study. The purpose of the study was to answer the following questions, and to mechanize the solutions.

1. What is the expected number $E(M)$ of sections missed, provided N bombs hit a target area comprising n specified sections?
2. What is the probability $P(M \leq r)$ that the number of missed sections M will not exceed r ?
3. What number of bombs N is needed in the target area in order to achieve a specified probability, $P(0 \leq r)$, of hitting every section?

The emphasis is on large values of n and small values of r .

Method of Analysis. An exact expression for $E(M)$, the expected number of missed sections, is given by

$$E(M) = n \left(1 - \frac{1}{n} \right)^N ; \quad (1)$$

the variance σ_M^2 of the number M of missed sections is

$$\sigma_M^2 = n \left(1 - \frac{1}{n}\right)^N + n(n-1) \left(1 - \frac{2}{n}\right)^N - n^2 \left(1 - \frac{1}{n}\right)^{2N} \quad (2)$$

An exact solution for $P(M \leq r)$, the probability

then equations (1), (2), and (3) may be replaced by the following approximations:

$$E(M) \approx m \quad (5)$$

$$\sigma_M^2 \approx m \left(1 - \frac{m}{n}\right) \quad (6)$$

$$P(M \leq r) \approx e^{-m} \sum_{j=0}^r \frac{m^j}{j!}, \quad (7)$$

where

$$m = ne^{-\frac{N}{n}} \quad (8)$$

Results. The results of the study have been tabulated in ten charts, based on the exact expression, equation (3) which show the dependence of the probability, $P(M \leq r)$, that at most r sections will be missed, as a function of the number N of bombs in the target area. Each chart contains curves for $r = 0, \dots, 4$. The parameter running from chart to chart is n , the number of sections in the target area, which takes the values 10, 20, 50, 100, 200, 500, 1,000, 1,500, 2,000, and 5,000. A typical chart is reproduced in Figure 1.

When equation (7) is a satisfactory approximation, i.e., when $N/n > 3$ and the number n of sections is

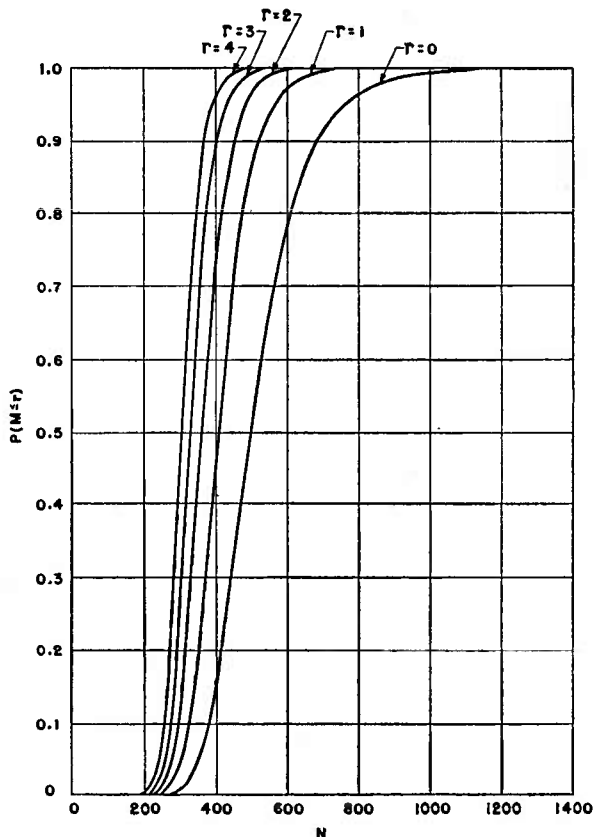

FIGURE 1. Probability, $P(M \leq r)$, of missing at most r sections out of $n = 100$ sections vs the number N of bombs.

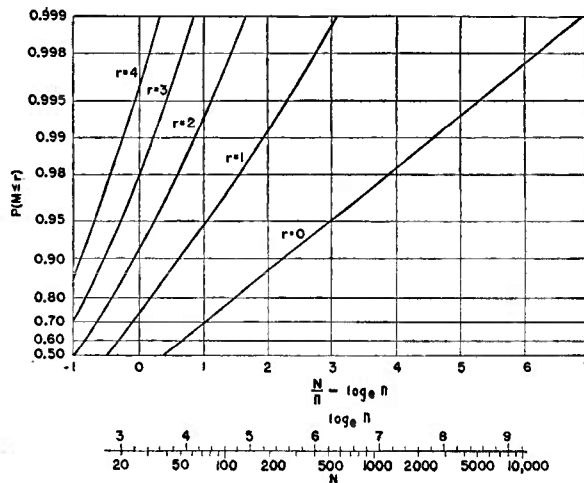

FIGURE 2. Probability, $P(M \leq r)$, of missing at most r sections out of n sections vs $N/n - \log_e n$, where N is the number of bombs. The auxiliary scale converts n to $\log_e n$.

that the number of missed sections M will be at most r , is given by

$$P(M \leq r) = 1 - \sum_{j=r}^{n-1} (-1)^{r+j} \binom{j}{r} \binom{n}{j+1} \left(1 - \frac{j+1}{n}\right)^N \quad (3)$$

An approximate solution for N , the number of bombs needed to achieve a specified probability, $P(0 \leq r)$, of hitting every section, is given by

$$N = -n \log_e [1 - P_n^{1/2} (0 \leq r)] \quad (4)$$

If the number n of sections is large and if the number N/n of bombs per section is greater than three,

sufficiently large, say greater than 20, then $P(M \leq r)$ is a function only of the variable m , and the above set of charts may be replaced by a single chart. This chart, shown in Figure 2, is drawn with the logarithm of minus m as abscissa:

$$\log_e (-m) = \frac{N}{n} - \log_e n \quad (9)$$

An auxiliary scale facilitates finding $\log_e n$ from n .

Both equations (6) and (7) have been mechanized in a circular slide rule version under the perhaps unfortunate title *Area-Bombing Probabilities*—unfortunate in that the unwary may be encouraged to apply it to a wider class of problems than is legitimate. This slide rule is shown in Figure 3.

It will be observed that the answers to several problems may be read at a single setting of the disk and/or radial index; also, that it is possible to read

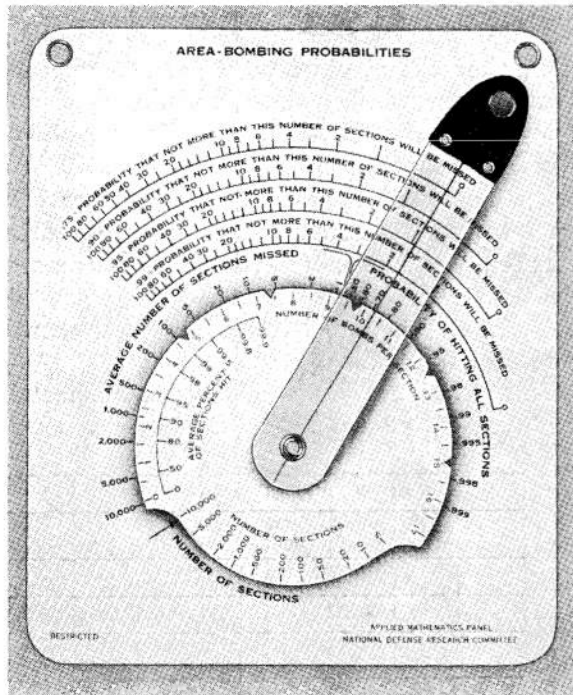

FIGURE 3. The AMP *Area-Bombing Probabilities* slide rule.

or set to values of n , the number of sections, and to values of N/n , the number of bombs per section, which are outside the range for which equation (7) is a good approximation. In this region the slide rule has been so calibrated as to overestimate the bomb requirement, N .

A person using the graphs, or the slide rule, should take care to apply the results only to situations in which the fundamental assumption—statistically uniform distribution of bombs over the target area—is at least reasonably well satisfied.

The formulas are developed and the charts are presented in an AMP report.¹

A small number of slide rules have been manufactured for distribution to operations analysts and other personnel in the Services.

5.3

PROBABILITY OF HITTING AT LEAST k OUT OF n SPECIFIED SECTIONS FOR STATISTICALLY UNIFORM DISTRIBUTIONS

This study is similar in principle to the one discussed above, but different in emphasis and in a detail or two. It is also, in a sense, an extension of the study discussed in Section 2.5, which was concerned with the slide rule for *Small-Target Bombing Probabilities*.

Its motivation may be traced to the need to estimate bomb requirements on targets which contain a number of especially important units, and where it is necessary or desirable that several of these units receive hits. As examples, one may cite the elements of a German V-1 installation, the compartments of a ship, or the units in a battery of coke ovens.

Purpose of the Study. The purpose of the study was to calculate the probability of hitting at least k out of n specific sections, when n is small. In contrast, the preceding study was concerned with the probability of hitting almost every specified section out of n , when n is large. But the major difference between the studies lies in the fact that here the probabilities are not conditional, i.e., account is taken of the probability that the bombs hit the target area, as well as of their distribution over the target area provided they hit it.

Method of Analysis. Let p be the single-shot probability of hitting any specified section in a target area comprising n sections. As in the above study, each section has an equal probability of being hit, but here $np \neq 1$ since p will be assigned values less than $1/n$. Then the probability, $P(H \geq k)$, that the number H of sections will exceed k is determined by

$$P(H \geq k) = 1 - \sum_{r=1}^k \binom{n-k+r-1}{n-k+r} [1 - (n-k+r)p]^N, \quad (10)$$

where N is the number of bombs.

Results. Values of $P(H \geq k)$ have been calculated from equation (10) for values of k , $n = 1, 2, \dots, 10$, and for $p = 0.1$ and 0.01 . Additional calculations suggest that if the value of p , say p' , is less than 0.01 , then

$$P_{p=p'} \approx \frac{0.01}{p'} P_{p=0.01}, \quad (11)$$

approximately.

It was planned to calculate equation (10) for more values of $p > 0.01$, so as to facilitate interpolation; however, this work ceased when the war ended.

The results are displayed on 20 charts, of which Figure 4 is an example. Each chart is for a fixed value of n and a fixed value of p . The probability, $P(H \geq k)$, of achieving hits on at least k of the n sections is

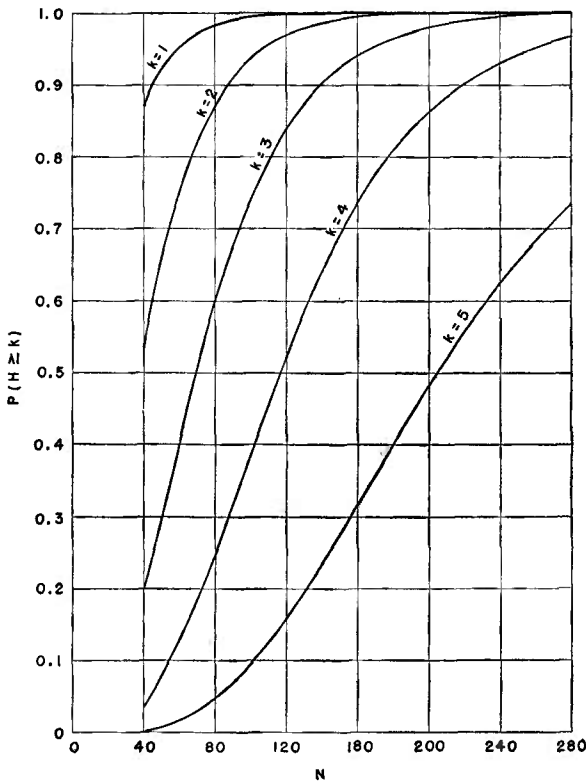

FIGURE 4. Probability, $P(H \geq k)$, that at least k out of $n = 5$ sections will be hit vs the number N of bombs, for the case where the probability of hitting a section is $p = 0.01$.

plotted against the number of bombs N . The various curves on a chart correspond to the values of k , which range from 1 to n .

The charts appear in a note² written by AMP.

5.4 CONDITIONAL PROBABILITY OF HITTING ALL UNSPECIFIED SECTIONS FOR STATISTICALLY UNIFORM DISTRIBUTIONS

This study differs from that discussed in Section 5.2 only in that the subdivision of the target area into sections is contemplated as an a posteriori event instead of as an a priori event. It arises, for example, in connection with the problem of neutralizing bomber runways so that they cannot immediately be used as fighter strips.

Purposes of the Study. The purposes of the study were:

1. To determine the number N of bombs, distrib-

uted with statistical uniformity, which must hit a bomber runway in order to preclude, with confidence α , the subsequent discovery and use of an undamaged section suited to fighter aircraft.

2. To determine, if possible, a rough rule-of-thumb by which the area-bombing probabilities slide rule (see Section 5.2 under *Results*) may be adapted to this problem.

Method of Analysis. The bomber runway is of length L and width W and one wishes to pit it so that the probability will be P that no fighter strip of length l and width w will remain. The problem is simplified by assuming that possible fighter strips must have their sides parallel to those of the bomber

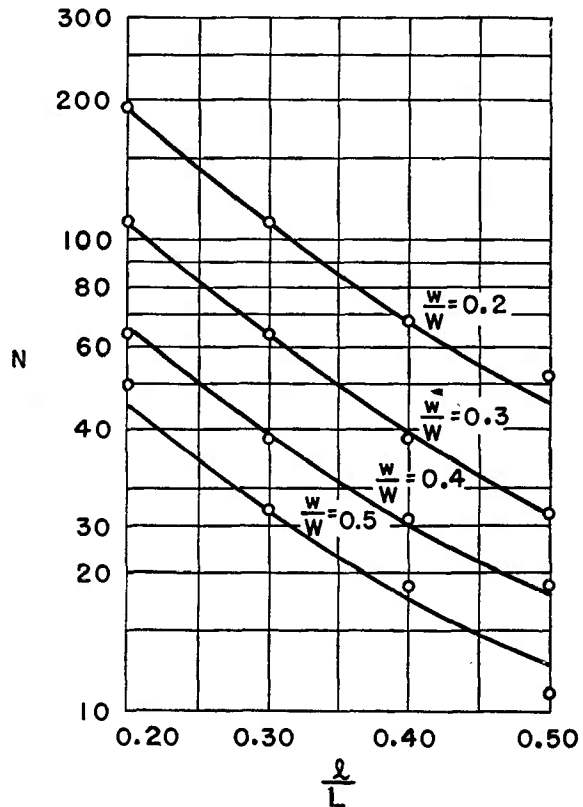

FIGURE 5. Number N of bombs required to give a 0.5 probability of eliminating all fighter strips of dimensions $l \times w$ from a bomber strip of dimensions $L \times W$, plotted against l/L .

runway. Since W is usually quite small compared to L , this is probably not a serious limitation.

The problem was solved by synthetic bombing. The coordinates of a bomb were taken from a two-digit table of random numbers, the impact point so found being marked on a chart comprising 100×100 lattice points. After each bomb was plotted the chart was examined to see whether all possible fighter

strips of given dimensions had been eliminated. When all rectangles of a given size had been eliminated, one noted the number N of bombs which had been plotted; this was continued until the smallest fighter strips of interest had been eliminated. This process was repeated until ten charts had been prepared, which yielded ten observations on the decisive values

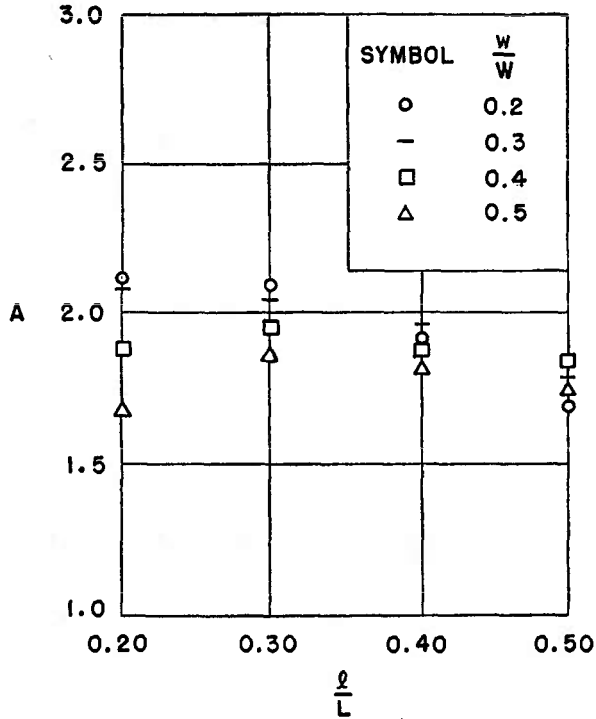

FIGURE 6. Correction factor A , indicated by the curves of Figure 5, to be applied to the slide-rule results, the purpose being to widen the class of problems to which the slide rule is applicable.

of N for each fighter-strip size of interest. In the present investigation the values 0.2, . . . , 0.5 for l/L , and for w/W , were considered.

If, for a given fighter-strip size, the ten observations are arranged in ascending order, say N_1, \dots, N_{10} , then a value midway between N_5 and N_6 is an estimate of the number of bombs required to give a probability P of success of 0.5. Similarly, a value midway between N_9 and N_{10} provides an estimate of N for $P = 0.9$.

Values of N determined from the area-bombing probabilities slide rule, by entering the number of a priori sections, $n = LW/lw$, and the desired value of the probability P of hitting every section, are compared with the empirically determined solutions to the present problem.

Results. The study resulted in preparation of a

set of graphs for each value of P , 0.5 and 0.9, in which N is plotted against l/L , for $w/W = \text{constant}$, and a family of consistent curves is drawn. One of these graphs is displayed in Figure 5.

From comparisons, of the type shown in Figure 6, of these values with those given by the just suggested use of the slide rule, one sees that a simple and accurate correction factor does not exist which can be applied to the slide rule results, for the factor depends on the value of w/W and, as a matter of fact, on the value of P . However, the factor usually lies in the range 1.5 to 2.0, and decreases as P increases.

If very much application arises for this type of problem, the present work can afford to be extended; the material covered here is a small exploratory study.

The work described above is reported as a working paper³ of AMP's Bombing Research Group at Columbia University.

5.5 INCENDIARY BOMB ATTACKS ON GERMAN TARGETS

In connection with Army-Navy Project 23 [AN-23] a study was made of the fire-raising effectiveness of the principal incendiary munitions used against German industrial targets. The data, derived from Eighth Air Force and Royal Air Force operations, were rather scanty; it was necessary to select for study those cases in which pre-raid and post-raid photo coverage, as well as information from Intelligence, were unusually complete and detailed. The munitions studied were the 4-lb magnesium bomb, M50, extensively used by the British and occasionally by us, and the 70-lb gel-filled (30 lb of gel) bomb, M47, the principal fire bomb used by the Eighth Bomber Command.

Purposes of the Study. The purposes of the study were threefold:

1. To study several assessable characteristics of fire divisions, notably the linear dimensions, type of roof, and occupancy rating, with the purpose of determining their influence on the vulnerability of buildings to fire.

2. To judge the fire-raising performance of the two types of incendiaries, M47 and M50, under comparable circumstances of target and attack, for Eighth Bomber Command tactics.

3. To determine the optimum loads of 500-lb general purpose [GP] bombs and M47 incendiary [IB]

bombs which would cause the greatest damage to German industrial targets.

Method of Analysis. The principal part of the work deals with the estimation of the conditional probability p_f that a single fire bomb will start a serious fire—serious to structure or contents—if it strikes a

TABLE 1. Definition of *medium height* fire division categories, in feet.

Data	Fire division width category		
	Narrow	Medium	Wide
M47 USAAF	11-12	12-19	20-33
M50 RAF	12-14	14-18	17-22

Note. The medium width category is 50-99 ft. The height categories were made to depend on the width categories so as to avoid having empty cells. The low and tall height categories are defined implicitly by the above.

fire division of a given category. The fire division, i.e., the smallest set of rooms within fire resistant boundaries, is classified according to the combustibility of the roof and to the occupancy rating, defined as the percentage of the floor area covered by combustible material; according to the width and height of the fire division, narrow, medium, or wide

TABLE 2. Estimates of p_f for M47 under other-than-combustible roofs.

HE hits	Occupancy rating	Fire division width		
		Narrow	Medium	Wide
None	Low	0.60	0.10	0.05
	High	1.00	0.40	0.10
Some	Low	0.00	0.00	0.00
	High	0.60	0.20	0.05

Note. The dividing line between low and high occupancy lies between 20 and 25 per cent floor coverage. The cumbersome phrase "other-than-combustible" is used instead of "non-combustible" because the latter is a technical phrase which does not include "fire resistant."

and low, medium, or tall, as defined in Table 1; according to the presence or absence of high explosive [HE] hits and to the density of the bomb fall.

Results. The principal results of the study are given below.

With regard to fire division vulnerability, the fire divisions under combustible roofs burn more easily than those under other roofs. But the results regarding combustible contents, i.e., occupancy rating, are mixed. The probability p_f of serious damage under other-than-combustible roofs increases markedly

with occupancy rating, as evidenced by Table 2, whereas p_f fluctuates erratically with occupancy rating when the roof is combustible. The suggestion is made that photo interpretation and intelligence may have been inadequate in the latter case.

The more narrow the fire division the more freely it burns; the effect is marked. The effect of height is somewhat similar, i.e., the lower fire divisions have a tendency to burn more freely than the taller ones, but there is an exception: If the fire division is narrow, or of medium width, and low, there may not be enough oxygen to support a destructive fire. Numerical results for the M47 are given in Table 3.

TABLE 3. Estimates of p_f for M47 under combustible roofs.

Roof	Fire division width		
	Narrow	Medium	Wide
Low	0.50	0.40	0.35
Medium	1.00	1.00	0.20
Tall	1.00	0.15	0.00

High explosive hits are somewhat beneficial if the roofs are combustible, and the opposite tendency is noted for other-than-combustible roofs. HE hits are beneficial in the case of the narrow, low fire division, where increased ventilation is needed. With regard to density of bomb fall, the probability of serious damage with a single hit in a fire division is enhanced

TABLE 4. Dependence of p_f on bomb-fall density, for narrow fire divisions under combustible roofs attacked with M50 by the RAF.

Bomb-fall density	Occupancy rating (per cent)		
	0-15	20-30	>30
0.98(2)	0.00	0.04	0.26
2.00(4)	0.05	0.39	0.78
2.85(3)	0.06	0.39	0.97

Note. The bomb-fall density represents the average number of 1B sticks whose centers lie within a 700 X 700-ft square; the numbers in parentheses indicate the number of industrial regions included in the average. The values of p_f in the body of the table are averages of calculated upper and lower limits.

when the density is high, indicating that events in neighboring fire divisions are not independent, contrary to the assumption in most calculations, including the present ones. See Table 4.

For formation attacks in which equal loads of M47 or M50 are carried, it appears that these types of bombs produce quite comparable results. If the roofs are combustible, the results with M50 are estimated to be somewhat more favorable, and the opposite holds when the roofs are in the other-than-combustible category, as may be seen from Table 5. This table is derived from data and calculations based on five targets attacked by the Eighth Bomber Command using M50-type bombs.

With regard to the optimum IB/HE mixture the conclusions are tentative. The position appears to be that pure IB attacks are generally most favorable.

TABLE 5. Comparison of number of fires *observed*, when M50 is used, with number *expected*, when M47 is used; based on five targets.

Fire division width	Combustible roof		Other-than-combustible roof	
	M50 bomb	M47 bomb	M50 bomb	M47 bomb
Narrow	17	13.5	4	6.7
Medium	16	15.0	3	5.1
Wide	4	5.1	3	2.9

However, in the case of difficult fire targets, say ones with wide fire divisions under other-than-combustible roofs and having low occupancy rating, pure HE attacks are judged to be as efficacious as pure IB attacks. Mixed attacks appear to be least favorable, but the effects of HE on fire fighters and water mains have been discounted in the analysis.

The details of the results are presented in several AMP papers.^{4,5,6} A number of the details of analysis, not given explicitly in the AMP papers may be found in two British documents,^{7,8} and in progress reports⁹ of the Statistical Laboratory of the University of California.

5.6 BLAST EFFECT VERSUS BOMB SIZE

This study, undertaken at the request of the Joint Target Group, AC/AS Intelligence, Hq AAF is based on a very limited set of data relating to American and British bombs.

Because the British normally used mixed loads of incendiary and blast bombs, it is only in the exceptional case that one can confidently identify observed damage with blast effect. When this identification is reasonably certain, the fact that a score or more of

blast-bomb types were commonly employed makes it difficult to identify the observed damage with the type which produced it. This latter identification was attempted initially by ascribing to each bomb type the incident of observed damage which, on the basis of inspection and calculation, seemed most likely. It later became obvious that these data should be abandoned when a study of the American data, involving a single blast-bomb type and without the incendiary complication, indicated very great variability in the effect of blast. Accordingly, the study was confined to the American data, supplemented by a handful of British data whose antecedents were fairly well established.

Because of the limited data, greater interest may attach to the method than to the numerical results.

Purpose of the Study. The principal purpose of the study was to estimate with reference to German housing the mean area of effectiveness, *MAE*, of various large blast bombs. While it was planned to obtain such estimates for each of the principal munitions used by the American and British Air Forces, paucity of data restricts the study to the American 500-lb GP, the British 4,000-lb HC, the British 4,000-lb M2, and the British 8,000-lb HC bomb. Even for these four types the quantity of data is so small as to preclude making very reliable determinations of the *MAE*'s.

Method of Analysis. In order to measure the damage in each incident a transparent overlay is prepared. This comprises a set of concentric circles, the radius of the k th being proportional to k , and several sets of radial line segments, $6k - 3$ in number in the k th ring, which subdivide the rings into regions of equal area.

This overlay is placed on a tracing of the incident, its center at the estimated point of burst. Readings are made for the i th incident, of the area of buildings damaged, Y_{ik} , and of the area of buildings exposed to risk, X_{ik} , within the k th ring.

In this manner, for each type of bomb, two series of values were obtained,

$$\begin{aligned} X_{ik}, Y_{ik} \quad i = 1, \dots, n \\ k = 1, \dots, s \end{aligned} \quad (12)$$

where n is the total number of incidents relating to the specified bomb type and s is the greatest value of k for which the damage, Y_{ik} , is not zero. On the assumption that the variance of Y_{ik} is proportional to X_{ik} and to σ_k^2 (defined below), the best unbiased

linear estimate of the mean effective area for a given bomb type is

$$MAE = \sum_{k=1}^s A_k q_k, \quad (13)$$

where

$$A_k = (2k - 1)A_1, \quad (14)$$

the area of the k th ring,

$$q_k = \frac{\sum_{i=1}^n Y_{ik}}{\sum_{i=1}^n X_{ik}}, \quad (15)$$

and the least-square estimate of the standard error of MAE , μ , is determined by

$$\mu^2 = \sigma_0^2 \sum_k \frac{A_k^2 \sigma_k^2}{\sum_{i=1}^n X_{ik}}. \quad (16)$$

The symbol σ_0^2 is determined by

$$(N - \nu) \sigma_0^2 = \sum_k \sum_i \sigma_k^{-2} \sum_j (Y_{ijk} - q_k X_{ijk})^2 X_{ijk}^{-1}, \quad (17)$$

where the outer summation is overall bomb types, N stands for the number of terms in the triple sum, and ν stands for the number of q_k 's in the double sum over k and bomb type. Zero values of σ_k^2 , X_{ijk} , and q_k , as well as $q_k = 1$, are excluded from equations (16) and (17). Estimates of σ_k^2 , namely, V'_k are calculated from

$$(n - 1) V'_k = \sum_i (Y_{ik} - q_k X_{ik})^2 X_{ik}^{-1}. \quad (18)$$

The values of V'_k are plotted against k , and a hand-smoothed curve drawn, from which estimates of σ_k^2 ,

now relatively free from sampling fluctuations, are read.

Results. Although numerical results are obtained for each of the four bomb types treated, internal evidence suggests that misidentifications of bomb type with damage and/or unrepresentative sampling affect even the small sample of incidents which are finally retained. The 500-lb GP is the exception to this, but, while the estimate of MAE is believed to be unbiased in this case, the quantity of data is so small as to lead to a weak determination. Also, in the case of the 8,000-lb HC, it is possible to estimate a lower bound for the MAE with which to compare the value calculated by methods described earlier, which may be considered as an upper bound.

The results for these two bomb types are given in Table 6. From these values, i.e., about half an acre of destruction per ton of bomb weight in each case,

TABLE 6. Estimates of the mean effective areas MAE and of the standard errors for two bomb types against German housing; in acres per ton.

Bomb type	MAE	σ_{MAE}
500-lb GP	0.49	0.06
8,000-lb HC	0.49-0.56	0.04

it appears to be a matter of indifference as to which bomb is used. However, a very definite trend could in fact exist and yet escape detection in the present analysis.

A detailed discussion of the data and method of analysis is given in a memorandum¹⁰ prepared by AMP.





Chapter 6

TORPEDO STUDIES

6.1 INTRODUCTION

THE AMP carried out three substantial analytical and statistical studies on miscellaneous problems of increasing the tactical effectiveness of torpedoes in naval warfare.

The first of these studies was made for the Navy Bureau of Ordnance and dealt with the determination of the optimum spread angles for salvos of torpedoes launched from destroyers for various ranges, target angles, and number of torpedoes per salvo. The spread angle is defined as the angle between adjacent torpedoes in a salvo, and the optimum value of this for a given range, target angle, and number of torpedoes per salvo is that for which the probability of at least one torpedo hit is a maximum. One of the principal findings in this study for the particular conditions provided by the Navy was that a 1-degree spread angle for all conditions produced probabilities of hitting almost as large as those yielded by the optimum angle in each case.

The second study was one of comparing the effectiveness of a proposed submarine-launched torpedo, which would automatically zigzag several times across the path of the target ship, with that of an ordinary straight-course torpedo. This work was done for the Navy Operations Research Group. The principal specific result of this study was that attacks with the proposed torpedo were about as effective for bow attacks as for 70-degree target angle attacks, whereas the ordinary straight-course torpedo is only about one-sixth as effective in bow attacks and about three-fourths as effective in 70-degree target angle attacks.

The third study was carried out for Division 7.2, NDRC, and consisted of the computation of lead angles for aircraft torpedo attacks against maneuvering ships. Tables of lead angles were computed for a variety of combinations of range, altitude, and airspeed of attacking planes against target ships of various classes for different speeds, target angles at moment of release, and directions of turning.

In the next few sections a brief sketch of the methodology used in these three studies will be presented, together with a short summary of the principal results obtained by applying the methods.

6.2 OPTIMUM SPREAD ANGLES FOR TORPEDO SALVOS

6.2.1 The Problem

The purpose of this investigation was to determine, under a variety of conditions regarding range, target angle, and number of torpedoes per salvo, the spread angles in destroyer torpedo salvos which would maximize the probability of at least one hit on a non-maneuvering target. The lead angles for such salvos were determined on the principle of the Mark XXVII *torpedo director*.

The need for such an investigation is intuitively evident from the following consideration. Errors are made in aiming a torpedo at a given target—errors due to failure to estimate correctly target angle, range, lead angle, and errors of the torpedo itself about its own aimed course and about its assumed speed. These errors all combine so that they would produce, in a large number of trials, a distribution of errors by which the torpedoes would miss the target (or more precisely the center of the target). Now if torpedoes fired in a salvo should be too closely clustered there would be too much probability of their all missing the target. Of course, if one torpedo should hit, there would be a large probability of others hitting also. By spreading out the torpedoes, the probability of all missing the target can be reduced only at the sacrifice of reducing the probability of multiple hits. So the question arises as to how much spread is required to yield the greatest probability of at least one hit.

The study was requested by the Navy Bureau of Ordnance (Navy Project NO-188) and was carried out under AMP Study No. 71. The principal results of this work were reported by AMP in two publications.^{1,2}

6.2.2 The Fundamental Torpedo Triangle

If there were no errors involved in the operation of aiming and firing a torpedo from a destroyer at a non-maneuvering target ship, the situation would be represented by the triangle in Figure 1 composed of the following three lines:

1. The range line R from point of launching to the center of the target at that instant.
2. The line of run r of the torpedo.
3. The target's path between time of launching and time of hitting.

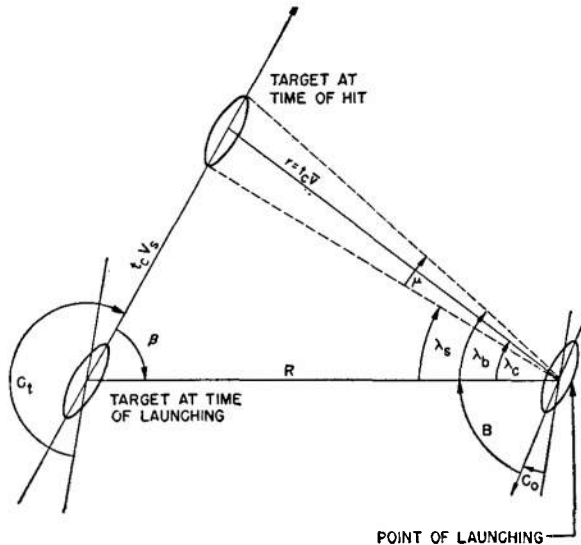

FIGURE 1. Diagram representing the firing of a torpedo from a destroyer at a non-maneuvering target ship.

The remaining symbols used in connection with Figure 1 are defined as follows:

- $2H$ = length of target ship
- β = target angle
- λ_c = lead angle for hit on center of target ship
- λ_b = lead angle for hit on bow of target ship
- λ_s = lead angle for hit on stern of target ship
- $\mu = \lambda_b - \lambda_s$ = angular aspect of target ship
- C_t = course angle of target ship, measured clockwise from an absolute meridian, as torpedo is fired
- C_0 = course angle of destroyer at instant torpedo is fired, measured similar to C_t
- B = bearing angle, i.e., the angle measured clockwise from the course of the destroyer to the range line
- v = actual water speed of torpedo
- \bar{v} = average water speed of torpedo
- v_s = speed of target ship
- $k = v_s/\bar{v}$
- t_c, t_b, t_s = times of torpedo run for hit on center, bow, and stern of target ship, respectively.

In the treatment of the problem, all distances are measured in yards and times in seconds.

If there were no errors of torpedo speed in deflection, the lead angle for a hit could lie anywhere be-

tween λ_b and λ_s . The lead angle λ_c for a hit on the center of the target ship will be approximately $\frac{1}{2}(\lambda_b + \lambda_s)$. This angle is given by the law of sines

$$\frac{\sin \lambda_c}{v_s} = \frac{\sin \beta}{\bar{v}}$$

or

$$\lambda_c = \arcsin (k \sin \beta) .$$

Under combat conditions the angle at which the torpedo is fired is measured from the attacking ship's axis. This angle is called the torpedo course angle, which is simply the sum of the lead angle and the bearing angle B . The target angle β is computed in the Mark XXVII torpedo director by the relation

$$C_t + \beta - 180^\circ = B + C_0$$

or

$$\beta = B + C_0 - C_t + 180^\circ .$$

6.2.3 The Probability of Getting a Hit with One Torpedo of a Salvo of Two Torpedoes

First, let us consider the problem of determining the probability of a hit with one torpedo of a salvo of two torpedoes. Let the fire control error have standard deviation, σ_f , and consider a fixed value, $F\sigma_f$, of the fire control error. The fire control error is the error made by the torpedo director in estimating the correct lead angle. If δ is the angular spread for the two torpedoes, then the angular errors (for the torpedo of the salvo having the larger lead angle) will be distributed about a mean $(\lambda_c + \delta/2 + F\sigma_f)$, with standard deviation σ_a . The torpedo speeds will be distributed about mean \bar{v} with standard deviation σ_v .

If the errors in speed and angle are assumed to be independent and normally distributed, then probability $p(\lambda, v)d\lambda dv$ that the angular and speed errors of a torpedo run will lie in the intervals $(\lambda, \lambda + d\lambda)$ and $(v, v + dv)$ is given by

$$p(\lambda, v)d\lambda dv = \frac{1}{2\pi\sigma_a\sigma_v} \exp \left\{ -\frac{1}{2} \frac{[\lambda - (\lambda_c + \frac{\delta}{2} + F\sigma_f)]^2}{\sigma_a^2} - \frac{1}{2} \frac{(v - \bar{v})^2}{\sigma_v^2} \right\} d\lambda dv .$$

Now the bow and stern lead angles, λ_b and λ_s , depend on the speed v of the torpedo in such a way that the greater the value of v the smaller the values of λ_b and λ_s . Denoting λ_b and λ_s therefore as $\lambda_b(v)$

and $\lambda_s(v)$, it is seen that the probability of a hit from the torpedo under consideration is obtained by performing the integration

$$\int_z \int p(\lambda, v) d\lambda dv, \quad (4)$$

where z is the region in the λv plane for which $\lambda_s(v) < \lambda < \lambda_b(v)$.

If the range R is large as compared with the length of the target ship and if the standard deviation of the torpedo speed is small compared with \bar{v} , the angular aspect of the target ship, i.e., $\mu = \lambda_b(v) - \lambda_s(v)$, is approximately constant over the range of values of λ and v pertinent to the problem. In fact, the value of μ is approximately given by

$$\mu = \frac{H}{R} \left\{ \frac{2 \sin \beta + (k \sin^2 \beta)}{\sqrt{1 - k^2 \sin^2 \beta}} \right\}. \quad (5)$$

A good approximation to the integral expression (4) can be obtained under these conditions. This approximation is obtained by replacing the two curves $\lambda = \lambda_b(v)$ and $\lambda = \lambda_s(v)$ which bound the region by the two parallel straight lines

$$\lambda = \frac{\mu}{2} + D(v - \bar{v})$$

$$\lambda = -\frac{\mu}{2} + D(v - \bar{v}),$$

where D is the slope of $\lambda_c(v)$ at $v = \bar{v}$ and where $\lambda_c(v)$ is given by equation (1) with \bar{v} replaced by v , i.e.,

$$D = \frac{-180k \sin \beta}{\sqrt{1 - k^2 \sin^2 \beta}} \cdot \frac{\pi \bar{v}}{2\pi}.$$

On the basis of the assumptions made above under which the angular aspect of the target ship is approximately constant, these two parallel lines are approximately the same as the tangent lines to the curves $\lambda = \lambda_b(v)$ and $\lambda = \lambda_s(v)$ at the points for which $v = \bar{v}$.

The approximation to the probability expression (4) under these conditions may be written as

$$\int_{-\infty}^{\infty} dv \int_{\frac{\mu}{2} + D(v - \bar{v})}^{\frac{\mu}{2} + D(v - \bar{v})} p(\lambda, v) d\lambda \quad (6)$$

which may be simplified by a relation in the λv plane and one integration

$$P(F, \delta) = \frac{1}{\sqrt{2\pi}} \int_{-z_1 - Fz_2 - \frac{1}{2}z_3}^{z_1 - Fz_2 - \frac{1}{2}z_3} e^{-\frac{t^2}{2}} dt \quad (7)$$

where

$$\begin{aligned} z_1 &= \frac{\mu}{2\sqrt{\sigma_a^2 + D^2\sigma_v^2}} \\ z_2 &= \frac{\sigma_f}{\sqrt{\sigma_a^2 + D^2\sigma_v^2}} \\ z_3 &= \frac{\delta}{\sqrt{\sigma_a^2 + D^2\sigma_v^2}}. \end{aligned} \quad (8)$$

6.2.4 Probability of at Least One Hit with a Salvo of Two Torpedoes

The probability expressed by equation (7) is that of obtaining a hit by the torpedo (in a salvo of two torpedoes) having the larger lead angle, for the given fire control error F . The expression for this probability is written as $P(F, \delta)$ to show that it is a function of the fire control error F and the spread angle δ .

The probability of getting a hit with the other torpedo in the salvo of two torpedoes is obtained by replacing δ by $-\delta$ in equation (7).

The probability of at least one hit is 1 minus the probability of failing to hit with either torpedo. But the probability of failing to get a hit with either torpedo if the fire control error is F is $[1 - P(F, \delta)] \cdot [1 - P(F, -\delta)]$. If we assume that fire control errors f are normally distributed with standard deviation σ_f as a unit, then the probability of failing to get a hit with either torpedo, whatever may be the fire control error, is given by

$$Q_2(\delta) = \frac{1}{\sqrt{2\pi}} \int_{-\infty}^{\infty} e^{-\frac{f^2}{2}} [1 - P(f, \delta)] [1 - P(f, -\delta)] df, \quad (9)$$

and hence the probability of getting at least two hits for a given spread angle δ is

$$P_2(\delta) = 1 - Q_2(\delta). \quad (10)$$

6.2.5 Probability of at Least One Hit with a Salvo of n Torpedoes

In the case of a salvo of n torpedoes, for which the spread angle is δ , the probability of at least one hit is a straightforward extension of equation (10) given by

$$P_n(\delta) = 1 - Q_n(\delta) \quad (11)$$

where

$$Q_n(\delta) = \frac{1}{\sqrt{2\pi}} \int_{-\infty}^{\infty} e^{-\frac{f^2}{2}} \prod_{i=1}^n [1 - P_i(f, \delta)] df \quad (12)$$

where

$$P_i(f, \delta) = \frac{1}{\sqrt{2\pi}} \int_{-z_{i1} - fz_{i2} - \frac{1}{2}(2i - n - 1)z_{i3}}^{z_{i1} - fz_{i2} - \frac{1}{2}(2i - n - 1)z_{i3}} e^{-\frac{t^2}{2}} dt. \quad (13)$$

6.2.6

Standard Deviation of Fire Control Errors

The quantity σ_f , the standard deviation of fire control errors, is an important quantity in the computation of $P_n(\delta)$, and it can be estimated from the standard deviations σ_B , σ_{C_t} , σ_{v_s} , and σ_t , respectively, of the bearing angle errors, target course errors, target speed errors, and errors in setting torpedo tubes relative to indicated torpedo course angle. For it will be recalled from the discussion in Section 6.2.2 that the target angle is estimated by the Mark XXVII torpedo director by the equation

$$\beta = C_0 + B - C_t + 180^\circ,$$

and if the torpedo course angle is T , then

$$\begin{aligned} T &= B + \lambda \\ &= B + \arcsin(k \sin \beta) \end{aligned} \quad (14)$$

or

$$T = B + \arcsin [k \sin (C_0 + B - C_T + 180^\circ)].$$

Expanding T in a Taylor series about the true torpedo course angle T_0 and neglecting terms of second order and higher,

$$(T - T_0) = (\Delta\beta) \frac{\partial T}{\partial B} + (\Delta C_T) \frac{\partial T}{\partial C_T} + (\Delta v_s) \frac{\partial T}{\partial v_s}. \quad (15)$$

Squaring this equation, averaging the squared errors, assuming independence of errors, and evaluating derivatives, one arrives at

$$\begin{aligned} \sigma_f^2 &= \sigma_B^2 \left[1 + 2k \frac{\cos \beta}{\cos \lambda} + k^2 \frac{\cos^2 \beta}{\cos^2 \lambda} \right] \\ &+ \sigma_{C_T}^2 k^2 \frac{\cos^2 \beta}{\cos^2 \lambda} + \sigma_{v_s}^2 \frac{(180)^\circ \sin^2 \beta}{\pi^2 \bar{v}^2 \cos^2 \lambda} + \sigma_t^2 \end{aligned} \quad (16)$$

where σ_t is the standard deviation of the errors involved in setting the torpedo tubes relative to the indicated torpedo course.

The principal difficulty in actually evaluating σ_f lies in the paucity of data on the errors involved in measuring B, C_t, v_s , and torpedo tube setting. However, some information exists in the "standards of proficiency" listed in a memorandum³ on torpedo training exercises. On the basis of this information, σ_f varies from $2^\circ 54'$ to $1^\circ 54'$ as the target angle β varies from 10° to 90° , and the average of σ_f for all target angles is approximately $2^\circ 30'$.

6.2.7 Principal Computational Results

A very extensive set of computations of values of $P_n(\delta)$ [see equation (11)], the probability of at least

one hit in a salvo of n torpedoes, was carried out for three values of σ_f , namely 1° , $2^\circ 30'$, and 4° . For each of these values the value of $P_n(\delta)$, was computed for the following values of parameters:

Target speed $v_s = 25$ knots

Mean torpedo speed $\bar{v} = 33.5$ knots

Torpedo speed error $\sigma_v = 0.7$ knot

Torpedo angular error $\sigma_t = 0^\circ 30'$ or 8.9 mils

Number of torpedoes per salvo $n = 2, 4, 6, 8, \text{ and } 10$

Target angles $\beta = 10^\circ, 30^\circ, 60^\circ, 90^\circ, 100^\circ, \text{ and } 120^\circ$

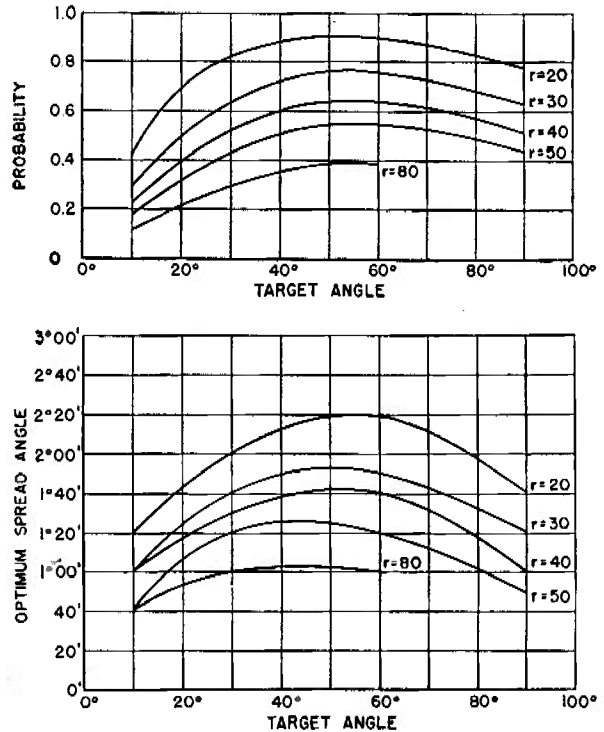

FIGURE 2. Optimum spread angle and probability of at least 1 hit with a salvo of 4 torpedoes for various values of r (range/target length) and for standard deviation of fire control errors equal to $2^\circ 30'$.

Ratio of range to target length $r = R/2H = 20, 30, 40, 50, \text{ and } 80$

Spread angles $\delta = 0^\circ$ to 4° , so as to include the optimum angle.

The results of these computations are given in both tabular and graphical form in an AMP report.² A typical graph is shown in Figure 2. On the basis of these calculations, numerous special tables and graphs are presented showing the effect of number of torpedoes, range, and standard deviation of fire control errors on optimum spread angles; effect of number of torpedoes, range fire control errors, and target angle on probability of obtaining at least one hit, and so on.

The most significant fact in connection with all these results is that although the optimum spread angle varies considerably from one set of conditions to another, the probability of securing at least one hit does not diminish much with small departures of spread angles from their optimum values. In fact it was found possible to select a single spread angle, namely 1° , which is relatively efficient for all conditions considered. More precisely, it was found that in about 80 per cent of the combinations of conditions under which $P_n(\delta)$ was computed the probabilities of at least one hit did not decrease by more than 6 per cent when the optimum angle was replaced by a constant spread angle of 1° .

All of these results apply to individual destroyer attacks. Brief consideration is also given to coordinated attacks of several destroyers on one or more target ships. The principal conclusion here was that effectiveness of such an attack can in general be maximized by having each attacking destroyer maximize the probability of getting at least one hit itself.

6.3 EFFECTIVENESS OF ZIGZAG TORPEDOES

6.3.1 The Problem

The problem here is to estimate the probability of hitting a target ship by a torpedo which would zigzag back and forth across the path of a target ship in a prescribed manner, as compared with the probability of hitting the target ship under the same conditions by using an ordinary straight-course torpedo. The proposed zigzag torpedo was considered for use in submarine operations against merchant ships.

Two types of zigzag torpedoes were proposed for consideration: (1) an efficient (ideal) one which could follow an intricate path with a minimum of overlap of its region of effectiveness, and (2) a more practically realizable one which would cross the prospective course of the target ship three times. In a torpedo of type (1) no restriction was placed on the path of the torpedo although torpedo range and speed, target speed, and the standard errors of estimates of target speed and course were specified.

6.3.2 Numerical Data

The problem considered was quite specific as far as numerical assumptions were concerned, and although the theory could be generalized without much

difficulty, it is convenient to consider the theory as specialized to the particular problem at hand.

The data provided for the problem was as follows.

Speed of torpedo = 30 knots

Maximum range = 4,000 yd

Range at firing = 1,500 yd

Loss in time and speed of torpedo at turns ignored

Estimated target speed = 10 knots

Target length = 420 ft

Standard deviation of estimate of target angle = 20°

Standard deviation of estimate of range = 10 per cent

Standard deviation of incidental errors = 4°

All errors assumed independent and normally distributed.

In order to make standard deviations of both course and speed errors unity, the following units were used.

1 linear unit (l.u.) = 1,688 yd

1 angular unit (a.u.) = 20° .

The torpedo speed is then 10 l.u./sec; the estimated ship's speed is $10/3$ l.u./sec; and half the ship's length is 41.445 l.u.

6.3.3 Method of Determining Efficient Unrestricted Torpedo Courses

It is convenient to use a stationary polar coordinate system with coordinates r (length of radius vector) and θ (angle measured from estimated course of ship). The origin of this coordinate system is the position of the center of the target at the moment of release of torpedo. We are concerned with the probability of hitting the ship at any point (r, θ) at time t , where t is measured in seconds from instant of release of torpedo. The relevant values of t lie between 0 and 237.

If v' denotes target speed, then, in order for the torpedo to hit the target at point (r, θ) at time t , the target course must be θ and the point (r, θ) must be not farther from the origin than the bow of the target nor nearer to the origin than the stern of the target. This means that v' must satisfy the inequality

$$v't - 41.445 \leq r \leq v't + 41.445. \quad (17)$$

If v is the error in estimating the target ship's speed, then

$$v = v' - \frac{10}{3}.$$

Substituting inequality (17) and using the fact that $r/t = v'$ if a hit occurs at (r, θ) then,

$$\frac{r}{t} - \frac{10}{3} - \frac{41.445}{t} \leq v \leq \frac{r}{t} - \frac{10}{3} + \frac{41.445}{t} \quad (18)$$

must be satisfied if a hit is to occur at (r, θ) .

The inequality (18) means that corresponding to an actual path of a torpedo in the three dimensional space (r, θ, t) , there is an area of effectiveness in the plane of θ and v which includes all of the points for which a hit would occur. This area is a belt whose center is $(\theta, r/t - 10/3)$ and whose length (parallel to the v axis) is equal to $2(41.445/t)$. For any given path, the probability of hitting the target is the integral of $(1/2\pi) \exp[-\frac{1}{2}(\theta^2 + v^2)]$ over this belt (assuming θ and the errors in the speed of the target ship to be independent and normally distributed). This probability is conditional upon given incidental (angular) and range errors. Different errors would give a different path in r, θ, t space and hence a different belt in θ, v space. The absolute probability of a hit is the integral with respect to range and incidental errors of the product of this conditional probability by the error function of the range and incidental errors.

Any actual path of the torpedo

$$\begin{aligned} r &= r(t) \\ \theta &= \theta(t) \end{aligned} \quad (19)$$

determines the center of its belt in the θ, v plane by the relations

$$\begin{aligned} \theta &= \theta(t) \\ v &= \frac{r(t)}{t} - \frac{10}{3} \end{aligned}$$

and conversely, the center of the belt in the θ, v plane determines the torpedo path. For the equation of the center of the belt in the θ, v plane the form is $v = v(\theta)$ which is equivalent to

$$\frac{r}{t} - \frac{10}{3} = v(\theta). \quad (20)$$

But since the speed of the torpedo is constant (10 l.u./sec) we can write the equation for velocity in terms of horizontal and vertical components in polar coordinates, as

$$\left(\frac{dr}{dt}\right)^2 + \frac{\pi^2}{81} r^2 \left(\frac{d\theta}{dt}\right)^2 = 100. \quad (21)$$

Thus, equations (20) and (21) are equivalent to equation (19), showing that a torpedo path in r, θ, t space determines a belt in θ, v space and conversely.

6.3.4 Application of the Method Described in Section 6.3.3

The application of the method described in Section 6.3.3 is very laborious when a distribution of range and incidental errors is used. Actually, the application of the method has been carried out only for a few special cases in which range and angular errors were assumed zero. In particular, work was carried out for a straight-course torpedo for a target angle of 30° and a torpedo speed of 30 knots, and for an unrestricted zigzag torpedo that followed a course described as follows. It was assumed that the torpedo remained on a straight course for 67 sec, then carried out a series zigzag involving seven turns.

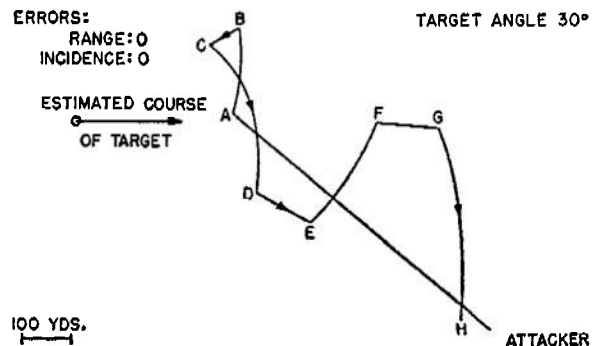

FIGURE 3. Path of zigzag torpedo when initial path is identical with that of straight-course torpedo. Target angle = 30° , range and incidental errors zero.

These turns were arranged so that the entire effective belt in the θ, v plane consisted of a series of rectangular strips so placed as to cover approximately a rectangle centered at the origin in such a way that there was no overlap nor any portion of the rectangle uncovered by the belt. The actual torpedo path in the water corresponding to this belt in the θ, v plane is very complicated. But the important point is that the path was an efficient one in the sense that the torpedo swept the area about the ship (as the ship moved) in such a way as to avoid both overlapped sweeping and "holes" of unswept area. The probabilities of a hit for this particular straight-course torpedo attack and the corresponding unrestricted zigzag torpedo attack were 0.22 and 0.57, respectively, (assuming range and incidental errors to be zero). The integration of $(1/2\pi) \exp[-\frac{1}{2}(\theta^2 + v^2)]$ over the belt in each example was approximated by counting elements of area of a grid of a two-dimensional circular normal distribution in which the probability was represented by small elements of area—each rectangle representing probability equal

to 0.001. The integral over any belt would be the sum of the number of elements of area which covered the belt. Figure 3 shows the actual path considered in the example, while Figure 4 shows the belts in the

θ, v space corresponding to the actual path shown in Figure 3. It should be noted that the belts for the zigzag path consists of approximately a series of non-overlapping rectangles.

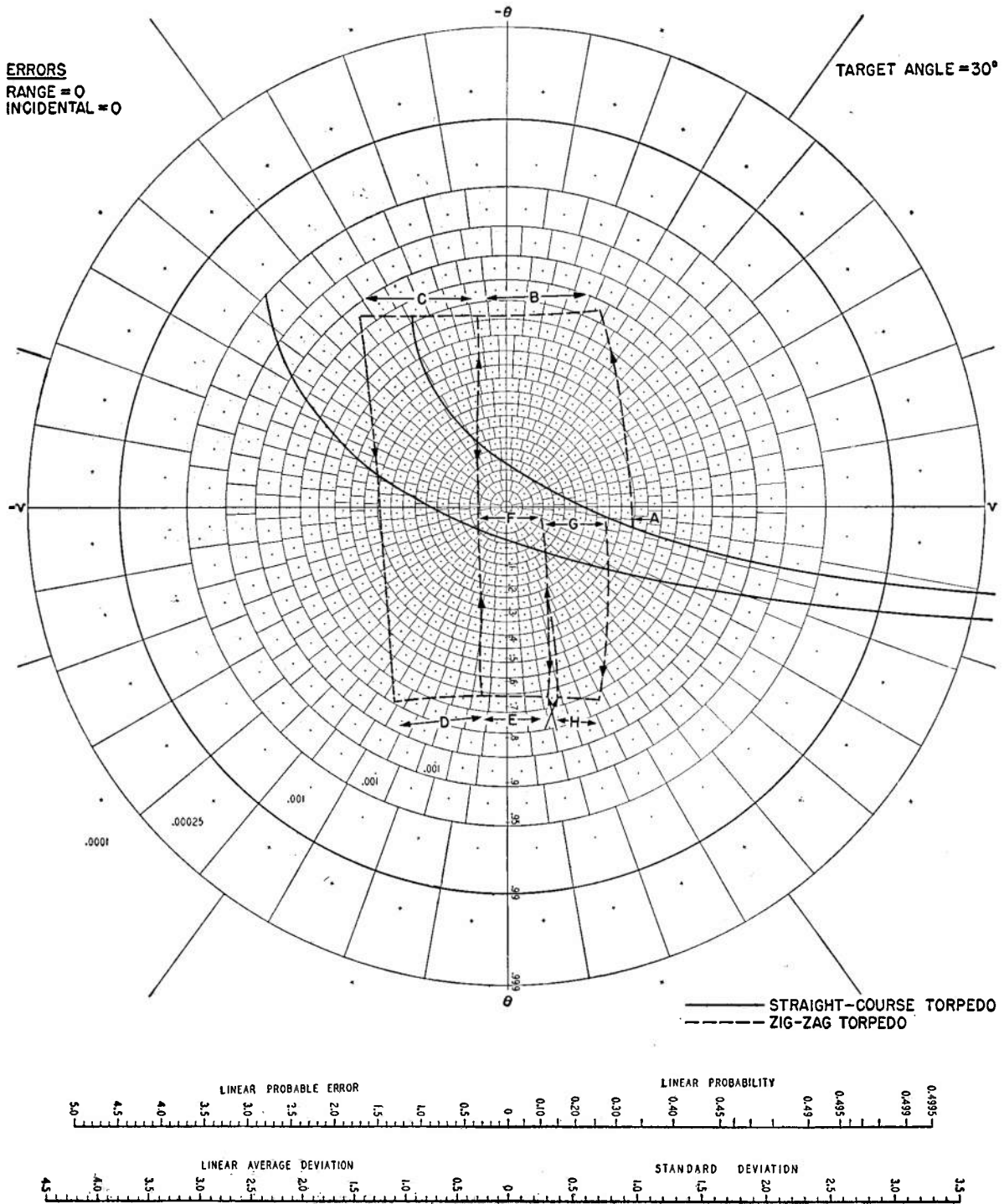

FIGURE 4. Belt covered in θ, v plane which corresponds to the path shown in Figure 3.

Using this procedure, a detailed study was made of the effectiveness of a zigzag torpedo fired from target angles, 71.6° and 0° (for the same conditions stated in Section 6.3.2) and restricted to cross the prospective course of the target ship three times almost at right angles. It was found that the probability of a hit from a zigzag torpedo in the 71.6° target-angle attack was about 35 per cent greater than that of a straight-course 71.6° target-angle attack, while for the 0° target-angle (bow) attack, the probability is about six times as large as that for the corresponding straight-course attack.

Bow attacks for a 60° saw-tooth zigzag torpedo path and a serpentine torpedo path made up of alternating semicircles were considered. These were found to be about half as effective as the zigzag path of three "almost" perpendicular crossings.

The details of this investigation, which was made at the request of the Navy Operations Research Group, have been discussed in an AMP report.⁴

6.4 AIRCRAFT TORPEDO LEAD ANGLES FOR ATTACKING MANEUVERING TARGET SHIPS

6.4.1 The Problem

The computation of lead angles for ship targets by existing American torpedo directors has been based on the assumption that the target ship moves ahead in a straight course at constant speed. This fact has restricted the usefulness of such directors against high-speed maneuverable warships. Combat reports from the Pacific indicated that evasive action was almost always being taken by Japanese warships by turning at maximum speed in the tightest possible circle. The problem then arose as to what lead angles should be used for aircraft torpedo attacks on maneuvering warships of various kinds and how much these lead angles differed from those for straight-course targets. AMP undertook a study of this problem at the request of Division 7.2, NDRC.

6.4.2 Numerical Conditions of Problem

Because of the absence of data on the maneuverability of Japanese warships, characteristics of ships' turns were obtained for several typical warships (CL, CV, and BB) of the United States Fleet from the David W. Taylor Model Basin. In the case of each ship the path of the ship is graphed from the time the execute order is given for a full over rudder

(35°) with a steady throttle. Initial speeds considered ranged from 15 to 30 knots. In graphing such a path, the position of the ship is located at the origin at the execute order with ship's axis coinciding with the y axis and turning to the right out into the first quadrant.

The location of the attacking plane is expressed in terms of its range and target angle relative to the ship as shown in Figure 5. The altitude of the plane

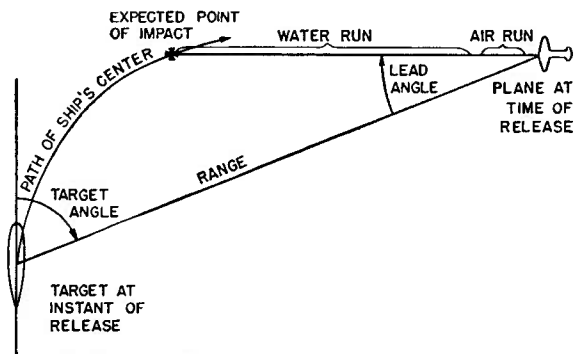

FIGURE 5. Position of target ship at instant torpedo is released, and expected point of impact.

and its airspeed are expressed in terms of a single parameter A , defined as the product of the torpedo's time of travel in air by the difference between its air and water speeds. As will be seen in Section 6.4.3, A was chosen because, for a given location of the plane, all combinations of altitude and airspeed yielding the same value of A require the same lead angle.

The following combinations of values of A and the range have been considered.

1. $A = 292$, Range = 1,000, 1,250, 1,500, 1,750, and 2,000 yd.

2. Range = 2,000, $A = 300, 600, 900$, and 1,200. For each case considered target angles were varied from 0° to 330° at intervals of 30° . The torpedo speed in water was assumed to be 33.5 knots.

If the position of a ship on a definite ship's characteristic curve is known, the position of the ship at future times is determined from the David W. Taylor Model Basin curves. If λ_s and λ_b are lead angles for a hit on the stern and bow of the ship, then any lead angle between λ_s and λ_b will result in a hit. In practice, however, aiming and running errors, and errors in estimating target ship's speed and target angle, will cause a distribution of errors of lead angle from a perfect lead angle which would deliver the torpedo at the center of the ship at the moment of impact. The problem then is to obtain an optimum estimate of lead angle.

6.4.3

Formula for Lead Angle

If the position of a ship on its characteristic curve is known at each instant of time t we may express the position of its center in the x,y plane described in Section 6.4.2 by means of the coordinates $x_c(t),y_c(t)$. In the analytical discussion of the problem of determining lead angle, the following notation will be used:

- t_0 = time interval between order to turn and time of sighting
- t_b, t_s = time intervals between time of sighting and times of hit on bow and stern, respectively
- t_a = time of torpedo's fall from plane to water
- R = range, i.e., distance from point of torpedo release to center of target at t_0
- U = distance from point of torpedo release to point of hit
- β = target angle at time t_0
- λ = lead angle for torpedo hit
- λ_b, λ_s = lead angle for hits on bow and stern, respectively
- $H(t)$ = ship's heading at time t , i.e., the angle measured clockwise between ship's axis and positive x axis
- h = height of plane at t_0 (in feet)
- a = airspeed of plane at t_0
- w = water speed of torpedo
- c,d = coordinates of plane at t_0
- θ_b = angle measured from negative direction of horizontal axis through (c,d) and measured clockwise to U for hit on target bow

$x_b(t), y_b(t)$ = coordinates of bow of ship at time t
 $x_c(t), y_c(t)$ = coordinates of center of ship at time t
 $x_s(t), y_s(t)$ = coordinates of stern of ship at time t .
 All distances not otherwise indicated are measured in yards, all times in seconds, and speeds in yards per second.

The situation from the time of sighting until a torpedo hit can be represented graphically as shown in Figure 6.

If we let $A = (a - w)t_a$, where $t_a = 2h/g$, then the total distance traveled by the torpedo is $A + t_b w$ for a hit on the bow and $A + t_s w$ for a hit on the stern. The condition for a hit on the bow is that the distance from c,d to the bow of the ship at time $t_0 + t_b$ be equal to the torpedo run, i.e.,

$$[x_b(t_0 + t_b) - c]^2 + [y_b(t_0 + t_b) - d]^2 = [A + t_b w]^2 \quad (22)$$

which is an equation for determining t_b . A similar

expression holds for a hit on the stern. The solution of equation (22) for t_b is carried out by trial and error and interpolation in any given case. Once the equation is solved for t_b , then the lead angle λ_b is determined from the expression (see Figure 6)

$$\lambda_b = \theta_b - [\beta - H(t_0)]$$

where

$$\theta_b = \arctan \left[-\frac{y_b(t_0 + t_b) - d}{x_b(t_0 + t_b) - c} \right]. \quad (23)$$

A completely similar procedure can be followed for determining the lead angle λ_s for a hit on the stern.

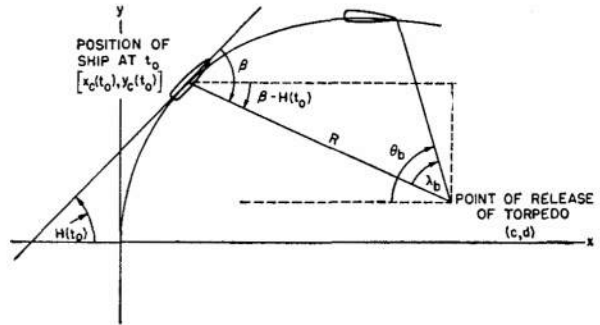

FIGURE 6. Diagram showing the coordinates and angles used in describing a torpedo plane attack against a ship.

The average of λ_b and λ_s in a single given case (corresponding to one characteristic curve) was taken as the lead angle λ .

Because of the fact that initial speed of a ship is unknown, the lead angle thus computed may be in error. To compensate for this possible error it was assumed that the maneuver is executed in such a way that the speed is increased three times out of four and decreased one time in four. The lead angle was computed for the characteristic curve for the decreased speed, and the two lead angles averaged in the ratio of 3:1. Investigation showed that the lead angle was not very sensitive to a variation of these weights from 1:1 to 3:1.

The theory of lead angles and methods of computing them have been presented in two AMP reports.^{5,6}

6.4.4 Extent of Applications of Procedure for Determining Lead Angle

Computations were carried out for lead angles in attacks on maneuvering light cruisers, heavy cruisers, and battleships under a wide variety of conditions. Speeds considered ranged from 15 to 30 knots. Some

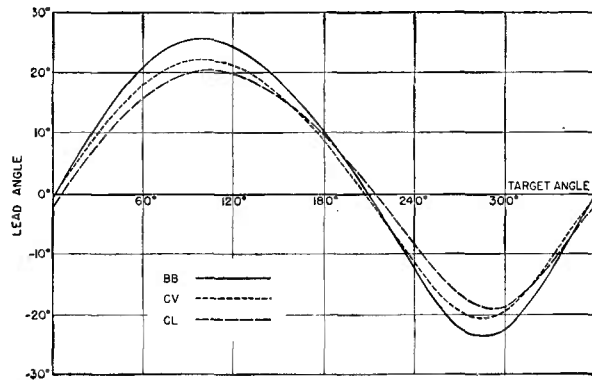

FIGURE 7. Optimum lead angles for an aerial torpedo attack on a battleship, a light cruiser, and an aircraft carrier. Range = 1500 yd, $A = 292$, torpedo speed = 33.5 knots, initial target speed = 20 knots, and observed speed = 20 knots.

cases were considered in which the speed was increased after the order for executing the maneuver was given, and cases were considered in which the

speed was decreased. Combinations of the quantity A and the range R mentioned in Section 6.4.2 were considered.

The lead angle has been presented in both tabular and graphical form as a function of target angle. Figure 7 shows a typical set of curves. Although the discussion has been presented in Section 6.4.3 in the case of a right turn by the ship, the same tables and graphs can be used in the case of a turn to the left by entering on the tables or graphs a target angle obtained by subtracting the actual target angle from 360° .

Tables and graphs are also presented showing the effect of each of the following factors on lead angle: target class, target speed, range, airspeed, and altitude. Comparisons of lead angles are made with lead angles computed on the assumption that the targets followed straight courses with constant speed. These tabulations and graphs have been presented in a report⁶ prepared by AMP.

Chapter 7

STATISTICAL STUDIES IN MINE CLEARANCE

7.1

INTRODUCTION

AMP WAS REQUESTED to make several statistical studies of the effectiveness of various explosive devices and procedures for clearing antitank and antipersonnel mines.

One of these studies was concerned with the design and statistical treatment of the results of an extensive experiment for testing the effectiveness of various linear explosive devices against several types of German and Japanese antitank and antipersonnel mines. In particular, curves were determined for the different mines buried at different depths, expressing the probability of detonation in terms of distance from the crater made by the explosive. This work was carried out in cooperation with the Land Mines Committee, NDRC, for the Army Engineer Board. A detailed description of the statistical methods used in the study are given in Section 7.2.

A second statistical study dealt with an investigation of the extent of clearance of mines to be expected by using against beach minefields 120-rocket barrages launched by a device known as the WOOFUS. This study was carried out by means of a miniature random number experiment, in which the radius of clearance of a single rocket and the errors involved in delivering the 120 rockets in a barrage were simulated. The principal conclusion of the study was that single barrages of rockets designed for the WOOFUS could not be expected to be effective against beach minefields. This study was carried out for the Joint Army-Navy Experimental Testing Board Section [JANET] and a description of the statistical methods used are described in Section 7.3.

A third statistical study in the field of mine clearance was an investigation of the effectiveness of aerial bombing in clearing paths through minefields which could be used by tanks. This work was also done by model experimental methods (described more fully in Section 7.4) in which radius of clearance and errors in placing bombs on the minefield were simulated. The principal result of the study was the fact that very large numbers of bombs would be required for clearing paths through minefields of the usual range of widths by this method. The work was done for the Army Engineer Board.

Most of the work in the second and third studies was done by experimental statistical methods in which model experiments simulating the conditions of the problem were repeated a number of times. The theory underlying the two studies can be formulated analytically in terms of appropriate mathematical formulas but the computation that would have been involved in the mathematical approach would have been prohibitive. The experimental methods developed are fairly simple but quite effective and the routine, once it is set up, can be made to operate at a clerical level. There are undoubtedly many other statistical problems of this type in military research which can be more effectively handled for practical purposes by experimental methods than by analytical methods.

7.2 CLEARANCE OF MINES BY LINEAR EXPLOSIVE DEVICES

During the war the Army Engineer Board carried out a testing program on several linear explosive devices for clearing paths through minefields. There were two classes of them. Devices of one class (Demolition Snakes M2, M2A1, and M3) were designed for clearing paths for tanks through antitank minefields, and devices of the other class (Carpet Roll, M1 Snake, Detonating Cable, and Bangalore Torpedo) were for similar use against antipersonnel mines. These devices ranged in length from five feet in the case of the Bangalore Torpedo, to 320 feet (of explosive) in the case of the Demolition Snakes.

The problem involved in testing these devices against mines was that of getting enough information about mine detonation produced by the devices to be able to state, with a reasonably high degree of confidence, the percentage of a large number of mines, of a given type planted at a given depth at a given distance from the device, which would be detonated by the device. To make such a test directly would require a prohibitive number of enemy mines or reproductions of them, even if they were available for such use in large quantities. The difficulty was largely overcome by developing a method of using the *Universal Indicator Mine* of the Army

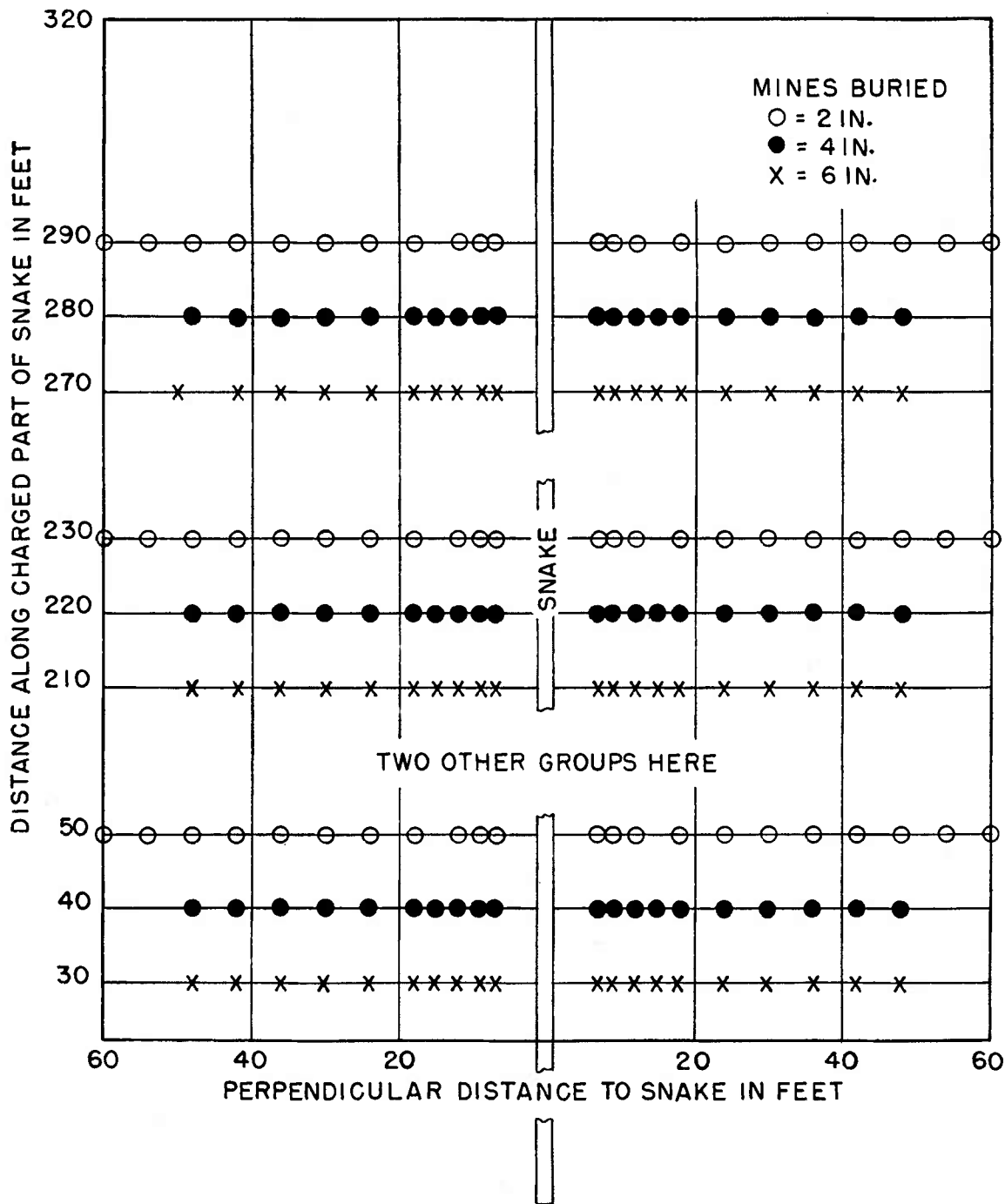

FIGURE 1. Universal Indicator Mine field pattern for M3 Snake.

Engineer Board, which was essentially a small gauge for recording peak pressure resulting from an explosion at any point where the gauge was placed. The relation between pressure measurements on this indicator and probability (or percentage) of detonation of any actual mine can be established on the basis of

a few mines. Accordingly, the indicator, being available in large numbers, could be used for studying the pressure field around a given explosive device at the moment of explosion. Also, one test with the indicators provided information about all mines which could be calibrated against the indicator. The prob-

lem therefore reduced to that of designing a field of Universal Indicator Mines around the device so that there were enough mines at each of several distances and at each of several depths to obtain a fairly reliable estimate of the average and variation of the pressure for each distance-depth combination. The experiment could be repeated for different soil conditions, e.g., dry or wet, and sand or clay.

A group of experiments of this type designed by AMP for testing three antitank mine Demolition Snakes and four antipersonnel mine-clearing devices

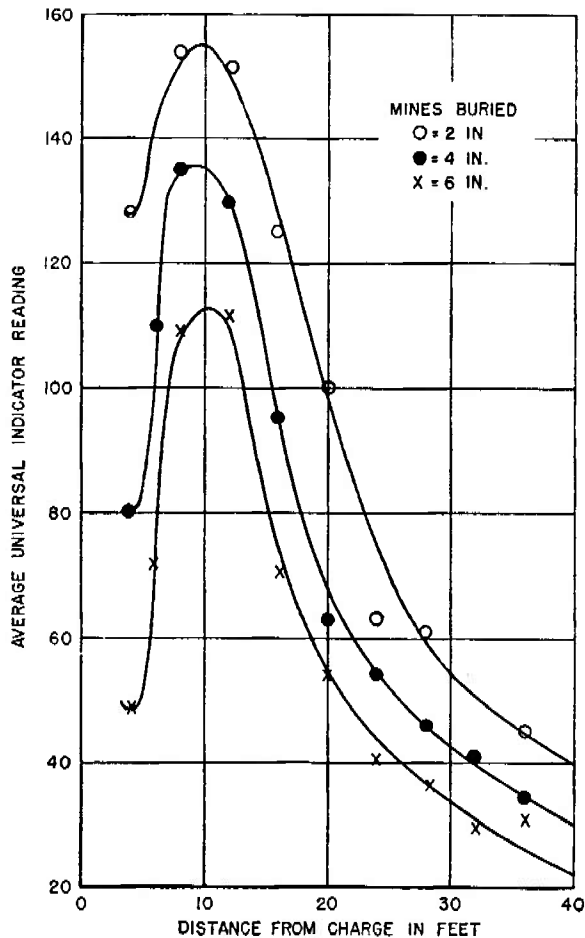

FIGURE 2. Average Universal Indicator Mine readings for 3-in. hose. Ground—wet. Detonation—high order.

were carried out at the Army Engineer Board Field Station at the A. P. Hill Military Reservation. In designing the experiment, a small amount of data was available from earlier preliminary experiments to indicate at what range of distances from the device the indicator mines should be planted in order to yield efficient results. It turned out that the indicator

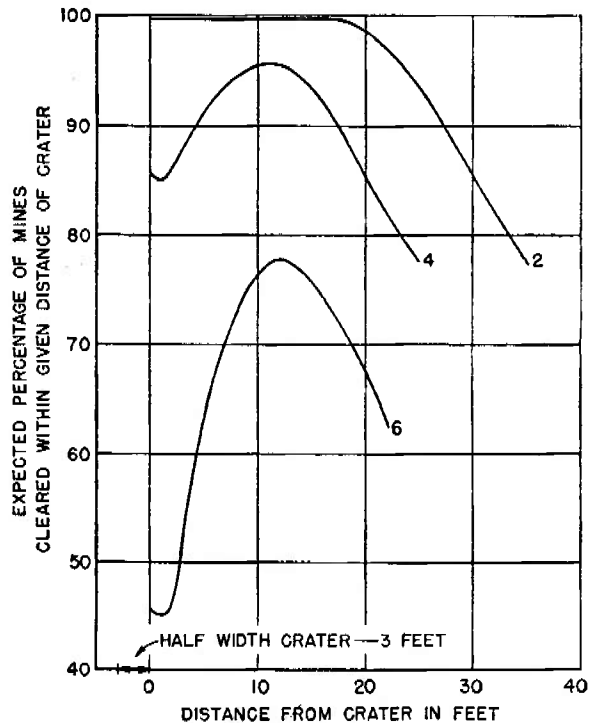

FIGURE 3. Expected percentage of German TM143 mines cleared by 3-in. hose in dry ground. Depth of burial (in inches) given at ends of curves.

mines had to be concentrated much more closely around the explosive device than originally thought necessary in order to get an efficient experiment. Figure 1 shows the layout of a typical experiment. The data from this group of experiments were an-

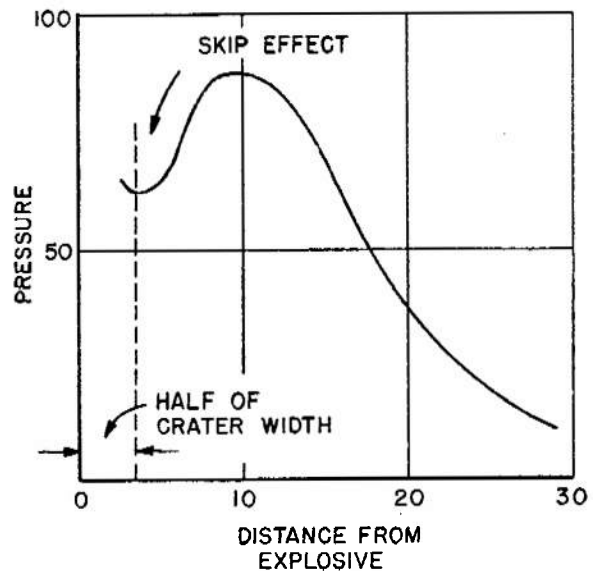

FIGURE 4. Diagram showing "skip effect" in pressure curve.

CONFIDENTIAL

alyzed and curves of average readings (pressure) for indicator mines buried at depths of 2, 4, and 6 in. against distance from center of crater were obtained for each of the six mine clearance devices under several soil conditions. Figure 2 shows a typical set of curves of average readings.

Enough German TMI43, Japanese J93, and Dutch Mushroom Top mines were available to be able to establish curves showing probability (or percentage) of detonation against pressure reading of the indicator mine. This made it possible to transform the curves described in the preceding paragraph to curves showing the expected percentage of detonation of TMI43, J93 or Dutch mines by each of the explosive devices at different depths of burial of the mines and for different soil conditions. Similar results were obtained for Schumines, Mustard Pots, and S mines, although the results were somewhat less reliable because of scarcity of the mines for testing purposes, and because these mines could not be calibrated accurately with the indicator mine. Figure 3 is an example of curves of expected percentage of detonation of German TMI43 mines.

An interesting by-product of this series of experiments was a great deal of quantitative information on the phenomenon of "crater effect" or "skip effect" in an explosion of the type produced by these devices. Skip effect manifests itself as a dip in the curve of pressure (plotted against distance from explosive) which occurs at the edge of the crater, as illustrated in Figure 4. The skip effect varies of course with explosive device, depth of burial, soil conditions, etc.

For complete details on the description of this group of experiments, together with graphs of the pressure curves and expected percentage clearance curves for the various linear explosive clearing devices, the reader is referred to a paper¹ published by AMP.

Only under exceptional circumstances would the explosion of a linear charge result in the detonation of 100 per cent of the mines in the crater or in a strip wide enough to accommodate a tank. Accordingly, under most circumstances there was a small probability that a tank track would hit a mine in passing through a minefield along a linear charge crater. At the request of the Army Engineer Board, a study was

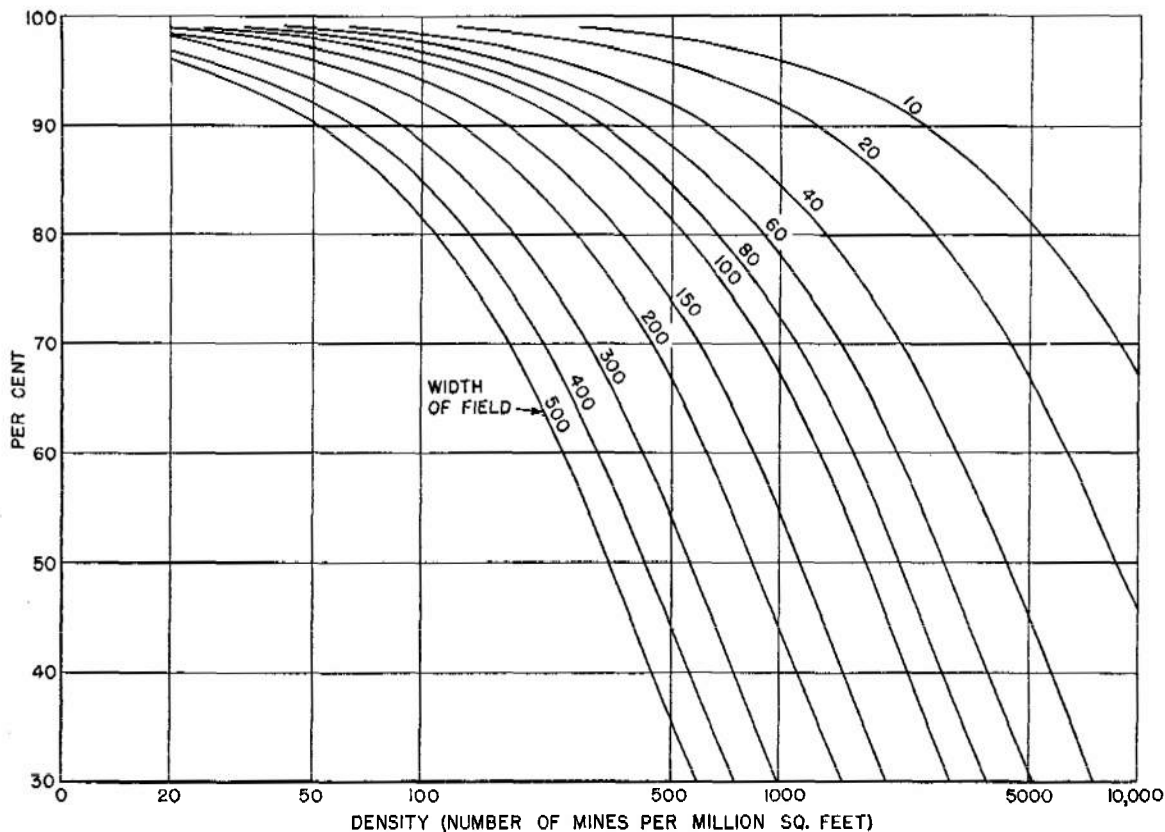

FIGURE 5. Curves for various field widths showing expected percentage of tanks passing through a minefield without striking mines, plotted against density of mines in minefield. Effective track width is 24 inches.

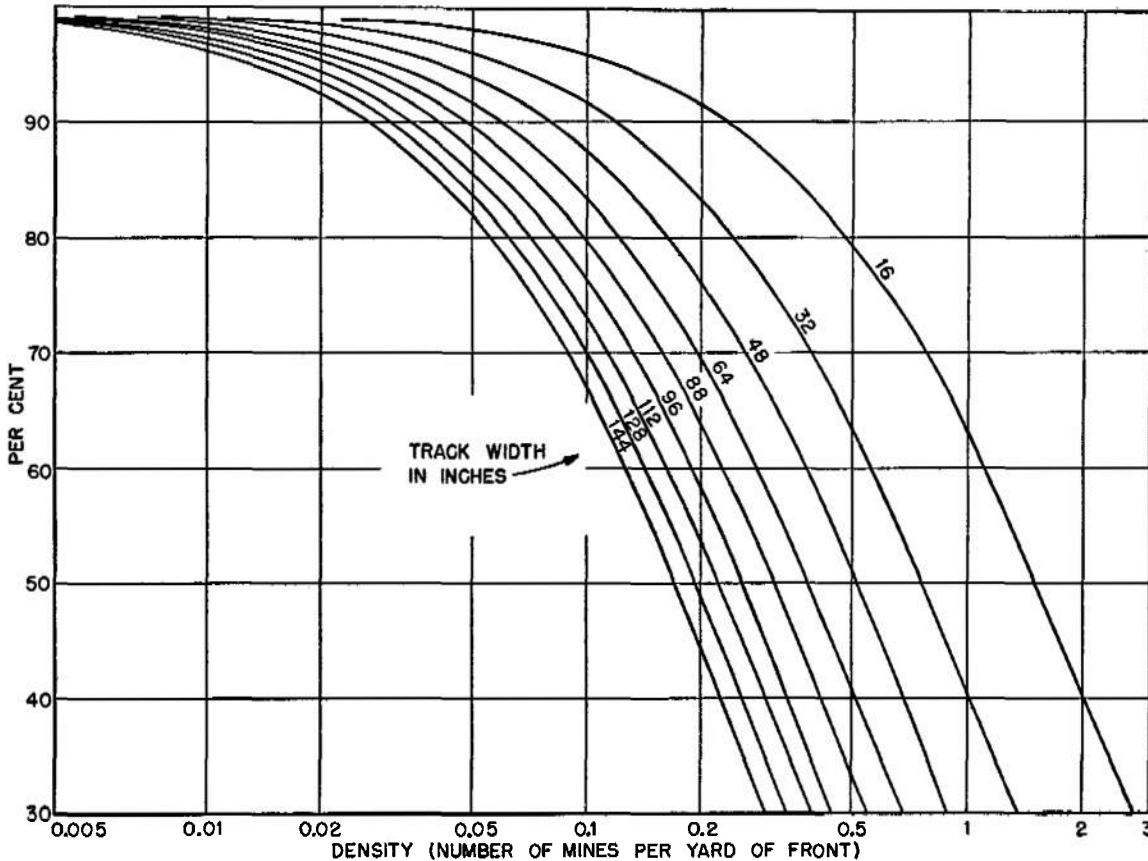

FIGURE 6. Curves showing expected percentage of tanks, of various total effective track widths, passing through a minefield without striking mines, plotted against density of mines when projected to front edge of minefield. (The label "Track Width" means "Total Effective Track Width.")

made of the probability of a tank, with given effective track widths, passing through a minefield of a given width without hitting a mine, or along the crater of a linear charge in which the density of mines had been reduced, without hitting a mine. Curves showing the probability of a successful crossing of a minefield plotted against mine density (in number of mines per million square feet) were prepared for effective track widths ranging from 8 to 40 in. and for field widths ranging from 10 to 500 ft. These curves of which Figure 5 is an example were presented in an AMP memorandum.² The same results were presented in a slightly different form in another AMP memorandum³ in which density of mines was expressed as number of mines per yard of front of the minefield. This amounted theoretically to considering all mines to be moved up to the front edge of the minefield, and then the density expressed as mines per yard. The effect of minefield width under this scheme showed up as increased density of mines per yard. Figure 6 shows the form in which these curves were issued.

7.3

CLEARANCE OF MINES BY ROCKET BARRAGES

Late in 1944, AMP was asked by the Joint Army-Navy Experimental Testing Board to make a statistical study of the effectiveness with which 120-rocket barrages launched by a newly developed device known as the WOOFUS could be used for breaching beach minefields. These launchers were mounted in a modified LCM(3). A few tests were made on an LCM in order to obtain information about errors due to roll, pitch, weave, and forward motion of the LCM.

Some static tests had been made on the 7.2-in. Mk5 demolition heads, with which the rockets were equipped, to find out how effective they were against Universal Indicator Mines (see Section 7.2). From these tests and from the known relationship between pressure readings on the indicator mines and probability of detonation of other mines, it was possible to estimate, for each type of mine, the relationship between the probability of detonation and distance

of mine from rocket at time of explosion. From this relationship an "equivalent radius of clearance" for the rocket head against any given mine buried at a given depth was determined. More specifically, suppose the probability of detonation of a mine at distance r is $f(r)$, and that the density of mines is constant. Then the equivalent radius of clearance r_0 is defined by

$$\pi r_0^2 = 2\pi \int_0^{\infty} r f(r) dr .$$

Range tables for the rockets for each of two sizes of launching motors (2.25-in. Mk3 for barrages at range of 200-250 yd, and 3.25-in. Mk1 for barrages at range of 400-500 yd) were available. The range of a rocket varies, of course, with the angle of elevation, and for a given motor there is inherent rocket dispersion in both range and deflection from one firing to another. The 120 rails in a WOOFUS launcher are set at angles of elevation varying from 25° to 45°. The statistical problem may now be briefly stated as follows. How can one combine the effects of the various factors which affect the accuracy with which a barrage is launched at a given area on the beach and simulate a launching enough times to determine reliably what fraction of the mines will be cleared on the average with one barrage, two barrages, three barrages, etc.? The area at which a barrage is aimed has been taken to be a rectangular one slightly smaller than the area covered by a barrage. For example, the rectangular area for short-range barrages is 120 by 240 ft and that for long-range barrages is 400 by 400 ft. It is perhaps worthwhile to restate that the factors which affect the accuracy and mine clearance effectiveness of a rocket barrage are: (1) inherent dispersion in range, (2) inherent dispersion in deflection, (3) pitch of ship, (4) roll of ship, (5) weaving of ship about a straight course, (6) speed of ship, (7) radius of clearance, and (8) ranging error of barrage as a whole.

A large number of model barrages were constructed to scale on paper to simulate the actual firing of barrages. In constructing each barrage, range tables were used for locating the theoretical points of impact, and these points were subjected to errors or displacements due to factors (1) to (6) above. More specifically the displacements due to (3), (4), (5), and (6) were applied to the theoretical impact points, the characteristics and magnitude of the displacements having been determined experimentally. After imposing displacements due to these factors the

resulting points of impact of a barrage were then subjected to random errors (1) and (2), the correct magnitude and randomness being controlled by tables of random numbers. After the final positions of the impact points had been determined in this manner, circles representing clearance were drawn. A large number of barrages were constructed for each of three sea conditions: No. 1, No. 2, No. 3. Sea conditions are reflected in magnitude (amplitude and period) of roll, pitch, and weave. The final factor (8) is an error which affects the barrage as a whole. It is the error caused by misjudging the proper time at which to release the barrage as the craft moves in toward the beach at full speed.

In actually simulating an attack on a given rectangular area on the beach, for a given sea state, a barrage is taken at random from the set corresponding to the given sea state, and its general position relative to the center of the area is determined by using random numbers which simulate the ranging error. By averaging the portion of the rectangular area (under attack) covered by circles of the barrage in a large number of attacks, one obtains an average or expected percentage of mines cleared for single barrages. Similarly by firing two independently aimed barrages at the same area, one can obtain an expected percentage of mines cleared by two barrages and so on for any number of barrages.

By using this method of analysis, curves giving the expected or average percentage of mines not cleared in the rectangular area attacked plotted against number of barrages aimed at the area, were obtained for seven types of mines (Flower Pot, Single Horn, Double Horn, Flower Pot with trip wire, Yardstick, J93, and TM43) for the twelve possible combinations obtainable from three sea states, two rocket motor sizes, and two types of explosive. These graphs, of which Figure 7 is an example, and the details of the analysis have been presented in an AMP report.⁴

7.4 CLEARANCE OF PATHS THROUGH MINEFIELDS BY AERIAL BOMBING

A problem in mine clearance in which there was a considerable amount of interest on the part of the Army Engineer Board, the Joint Army-Navy Experimental Testing Board, and the Land Mines Committee, NDRC, was that of the feasibility of breaching minefields by aerial bombing in circum-

stances where there would be no hazard to friendly troops. Experiments were made under the direction of the Army Engineer Board to test this method of breaching minefields. The results of these tests were rather inconclusive since it did not prove feasible to

make enough tests to determine the reliability of an estimate of the number of bombs required to breach a minefield under a given set of conditions. Accordingly, AMP was requested to undertake a statistical study for the purpose of obtaining reliable

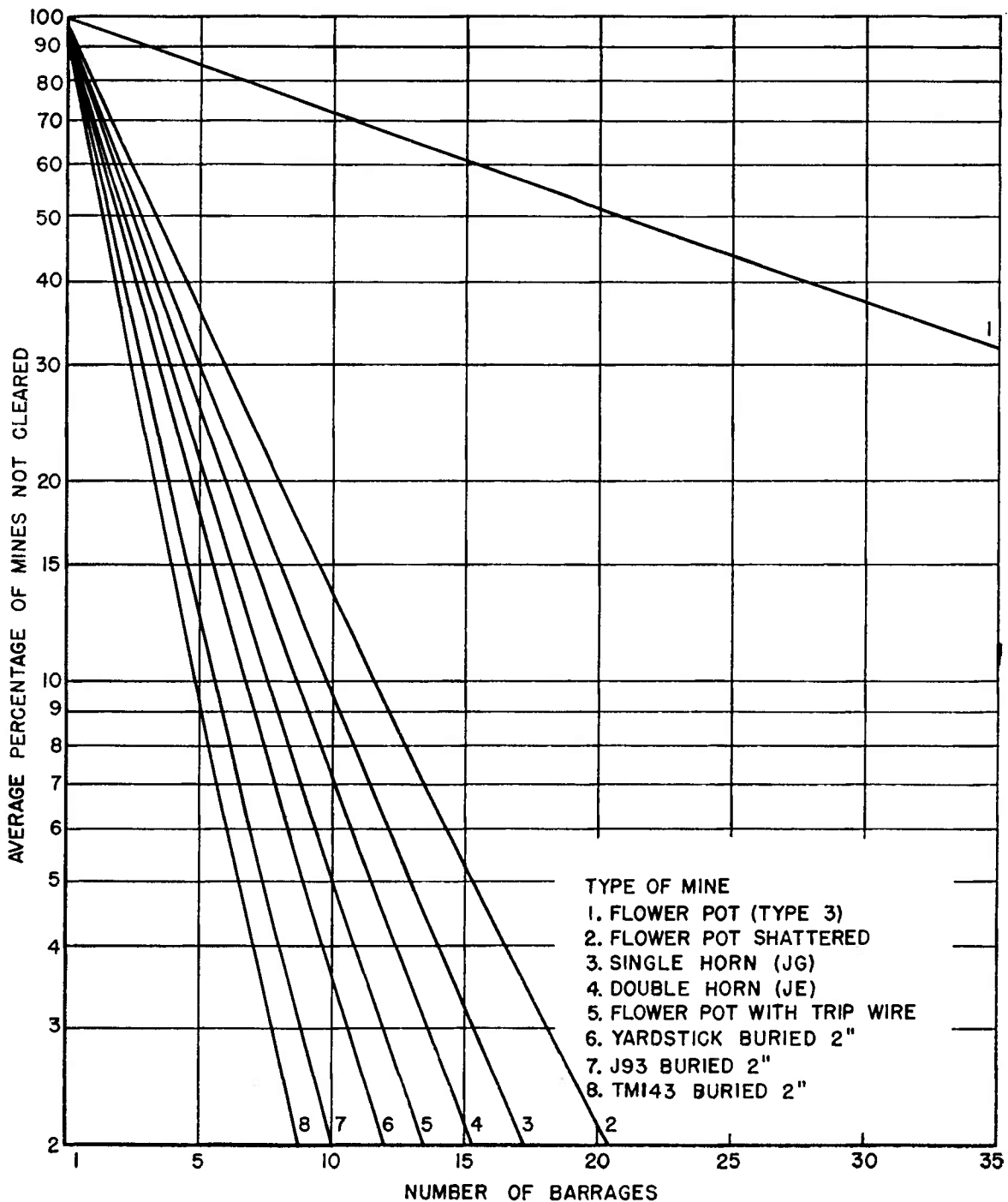

FIGURE 7. Graph showing average percentage of various types of mines not cleared by WOOFUS barrages. Rockets—TNT loaded, with 2.25-in. motors. Sea condition—No. 1. Target size—120 x 240 ft.

estimates of the number of bombs required for clearing paths through minefields under various conditions.

The general method of analysis used in dealing with this problem was similar to that employed in studying the effectiveness of rocket barrages. In other words, model experiments were carried out in which aiming errors and other factors affecting the location of bombs were simulated by random numbers, and regions of clearance for each bomb were idealized as circles. More specifically, for a given method of bombing, a given width of minefield, and a given radius of clearance a "bombing" experiment was carried out. A pattern of "bomb" points was gradually built up by continued "bombing." At various times in the experiment, i.e., after certain numbers of "planes" or "formations" had "attacked," an estimate was made as to what percentage of the best path (chosen by inspection) was cleared of mines. As an experiment progresses this percentage, of course, increases. The experiment was terminated after 40 to 80 "planes" had been "flown" (depending on the bombing conditions). Repeating this experiment a number of times yielded enough information to enable one to construct a curve showing the average or median percentage of clearance (called the 50 per cent curve) of the best path plotted against the number of "planes attacking." Similar curves based on any percentile (rather than median) percentage of clearance of the best path could also be drawn. In fact, the 90 percentile percentage curve (called the 90 per cent curve) is useful, since it gives a figure, for a given number of planes, representing the percentage of clearance which would be exceeded 90 per cent of the time in a large number of similar repeated attacks.

The details of this method of analysis have been presented in an AMP report.⁵ The method has been applied to five types of bombing, together with their associated bombing errors. They are:

1. Dive bombing with small aiming error.
2. Dive bombing with large aiming error.
3. Medium altitude bombing with single medium bombers.
4. Medium altitude bombing with single heavy bombers.
5. Formation bombing with heavy bombers.

The widths of minefields considered were 300, 600, and 900 ft. The radii of clearance used were 15, 20, 25, 30, and 40 ft. The path selected under each set of conditions as best is the one that would be most nearly covered by circles of the given radii.

The result of these statistical experiments were presented in thirty graphs.⁵ The thirty graphs correspond to the thirty possible combinations obtainable from the five bombing methods, the three minefield widths, and the two levels of confidence (50 per cent curves and 90 per cent curves) described earlier. On each graph are five curves corresponding to the five different radii of clearance considered. Each curve shows percentage clearance of mines in best path plotted against number of planes attacking, for the conditions specifying the chart and the particular curve in the chart. Figure 13 of Chapter 4 shows one of these thirty graphs.

The principal result of this study was the conclusion that a large number of bombs would be required to breach minefields satisfactorily, except possibly in the case of dive bombing against narrow minefields with AN Mk47 depth bombs equipped with air burst fuzes (40 ft radius of clearance).

An earlier study⁶ of the possibility of clearing paths through minefields by aerial bombing, under rather more restricted conditions, was carried out by AMP upon request of the Committee on the Demolition of Landing Obstacles. In this study two possibilities of clearance of path through a minefield were considered: (1) the release of a sufficient number of bombs to clear a path at a predetermined location across the minefield of width B , and (2) the release of several trains of sufficiently closely spaced bombs joined in a zigzag fashion so as to clear a zigzag path through the minefield.

In the case of possibility (1), the path across the minefield was laid out in advance. This is to be contrasted with the approach to the problem of land mine clearance taken in the study⁵ described earlier, in which the path was chosen after the bombing had been carried out, thus diminishing to some extent the number of bombs required. The types of bombing considered were formations of nine and eighteen planes, each plane carrying a specified number n of bombs to be dropped in train. The problem considered was that of detonating a mine at a designated place in the path by a specified number F of formations, where the planes in each formation were assumed to have dropped their bombs in formation from an altitude of 8,000 to 10,000 ft aiming at the center of the path. If the specified mine is located in a corner of the path, then P is smaller than the probability of detonation for a mine location anywhere else in the path. Thus, $100P$ represents the upper bound of the expected percentage of land mines

within the path which will be left unexploded by attacks from F formations. Thus, if P is very small it may be presumed that practically all mines within the path will be cleared. A nomogram was constructed which provided a relationship between B , R (radius of detonation), F , n , and P , so that any one of the variables could be determined for

specified values of the remaining four variables.

In considering possibility (2), i.e., the problem of establishing a path by joining tight strings (or trains) of bombs in a zigzag fashion, it was found that aiming errors and dispersion of bombs in train had to be of magnitudes too small to be realistic under combat conditions.

Chapter 8

STATISTICAL ANALYSIS OF THE PERFORMANCE OF HEAT-HOMING DEVICES

8.1

THE PROBLEM

IN 1944 an aerial experiment was carried out by the Optics Section, Bureau of Ordnance [BuOrd] to survey the thermal characteristics of various types of targets, and to determine the effectiveness of several newly developed heat-homing devices [HHD] in detecting these targets. The targets included factories and docks in various parts of the country and ships off shore. In carrying out these experiments the question arose as to what observations should be recorded and how they should be analyzed in order to determine the reliability with which a given device would indicate the presence and direction of the target under various conditions. AMP was requested to assist with the statistical aspects of this problem.

8.2

THE EXPERIMENTAL SET-UP

In setting up the experiment, provision was made for testing three types of HHD's namely Type A, Type B, and Type C.^a Type A was designed for measuring the thermal intensity of heat signals, while Type B and Type C were designed to indicate direction of thermal centers. Type B was gradually improved and used as the homing device for the FELIX (VB-6) heat-homing, high-angle bomb. These three experimental devices were mounted in an airplane in conjunction with a Farrand instrument and a 16-mm camera. The Farrand instrument was used to measure the heat intensity of a target and to indicate the thermal center of the target. The intensity was recorded on a waxed tape. The Farrand instrument and the camera (camera No. 1) were locked together so as to "see" the same picture on the ground. They could be rotated about an axis parallel to the line of flight, and hence could be tracked across the target simultaneously as the plane moved over the target. The three candidate instruments were free to be tracked "above" or "below" the target as seen by an observer oriented in the plane so as to be facing the right side of the plane and looking down. In this orientation, the left of the field of view was therefore the forward direction of flight. An instrument panel

^a Type A refers to the Aiken HHD, Type B to the Bemis HHD, and Type C to the Offner HHD.

was designed for recording the signals yielded by the three candidate instruments. For Type B and Type C there were, in each case, four lights arranged as shown in Figure 1. When either of these two instruments performed perfectly, then when it was aimed at a point up and to the left of the target (high thermal center) with respect to the oriented observer men-

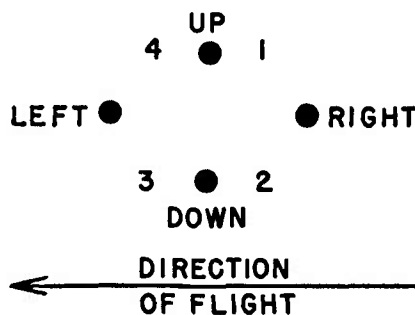

FIGURE 1. Diagram showing arrangement of lights for Type B and Type C heat-homing devices.

tioned above, the two lights marked down and right (or more briefly the pair 2) would flash on, thus indicating that the target was down and to the right. Similarly, this holds for other aimed positions with respect to the target. This instrument panel was photographed by a second camera (No. 2) which was synchronized with the camera aimed at the target.

Thus, as the plane flew over the target, camera No. 1 and the Farrand instrument would be aimed at the ground so as to track across the target from left to right. The Type A, Type B, and Type C instruments could be aimed "above" or "below" or "on" the target, independently of each other and of the Farrand and camera No. 1 set-up. Camera No. 2 photographed the instrument panel which showed the signals of the three candidate instruments. The operators of these three instruments signified whether on a given run they were tracking above or below the target, and by how much (in mils).

8.3

ANALYSIS OF THE DATA

The data on a given run across a given target was compiled from information on the two films taken by synchronized cameras No. 1 and No. 2, and



FIGURE 2. Photograph showing the direction of target indications in four runs across the Emerson Turret Plant. Runs 9005 (B) and 9006 (A) were traced below and above the target respectively, while runs 9004 and 9007 were traced on the target.

from a data sheet indicating whether the Type B (Type A or Type C) instrument was being tracked "above," "below," or "on" the target. A double projector was devised for running the two films simultaneously. A coordinate system was set up on the screen on which the target film was projected in such a way that each dimension of a single projected frame of the film was divided into five equal parts

(screen units)—the area of the frame therefore being divided into twenty-five equal rectangles. Thus, the position of the target could always be specified on each frame. Therefore, by running the films through the projector, one is able to reconstruct, for a given airplane run, the direction of thermal center indicated by Type B or Type C as it is being tracked "above," "below," or "on" the target. Figure 2 shows

an example of how these indicated directions can be reconstructed along a Type B or Type C track. The four tracks represent Type C runs corresponding to four airplane runs across the target North-South, South-North, East-West and West-East. The short spurs represent the directions of thermal centers indicated by Type C at various points of the path. The letters *A* and *B* after the numbers indicate Type C tracking above and below the target, respectively. The numbers are used to identify the runs. A number without *A* or *B* means tracking on the target.

In addition to being able to reconstruct a track for Type B or Type C with indicated directions of target (thermal centers) along the track, it was possible to determine the reliability with which either device would indicate direction of thermal centers of a given intensity as measured by the Farrand. In other

TABLE 1. Type C HHD target signals for a series of airplane runs.

Track	Up	Target position		
		Down	Right	Left
On target				
Right	1,604	999	1,023	1,580
Left	1,600	801	764	1,637
Total	3,204	1,800	1,787	3,217
Above target				
Right	123	104	79	148
Left	171	123	74	220
Total	294	227	153	368
Below target				
Right	251	81	166	166
Left	180	64	148	96
Total	431	145	314	262

words, one could make up a table showing frequency (number of frames) of indicated directions of thermal centers versus actual direction. Table 1 is an example of such a table for a series of airplane runs made in March 1944, using a model of the Type C device. It will be noted that Type C was tracked below the target in the case of a total of 576 frames and there are 431 "up" signals (correctly indicated signals). Similarly, this holds for other directions. The reliability of calling signals depends not only on the intensity of heat at the main target, but also on the presence of other thermal centers and on the sensitivity of the instrument. As may be expected, some targets were found to be thermally indistinguishable from the background, or even colder than background (for example ships early in the morning).

Reliabilities of direction signals of the Type B and

Type C instruments were statistically determined for a wide variety of targets, altitudes, times of day, and flight into or away from the sun. The relation between expected signal amplitude and percentage of correct signals as a function of distance from center was investigated. The behavior of signals for the thermal distribution found in land and water backgrounds was also thoroughly analyzed. The average duration of sustained signals from these two devices was determined under various conditions. The reproducibility of signal patterns for repeated airplane runs was studied. The results of these studies were reported in detail in several AMP reports.^{1,2,3,4,5} The main conclusions of the work reported in these reports, which pertain primarily to Type C, may be summarized as follows.

1. There was a distinct sun glare effect on all runs on which the HHD detector was focused in the direction of the sun.

2. There was a noticeable signal lag in indicating the target as the HHD swept over the target. This is an inherent feature of any electrical system.

3. The instrument clearly indicated the thermal differences between land and water. This difference was so great that it masked any thermal differences between the land and objects built on the land or ships anchored near the shore.

4. The results over ships at sea were much poorer than over land targets.

5. Almost perfect performance was obtained over very hot targets such as oil fire, and blast furnaces.

6. The results were definitely poorer at altitudes above 6,000 ft than below this altitude. Also poor results were obtained with heavy overcast skies.

7. Cold-homing might be feasible up to a few minutes after sunrise. Poor results could be expected for at least an hour after sunrise.

8. The target indications improved as the center of the HHD approached the heat center. The improvement closely paralleled the theoretical relative signal amplitude as a function of distance from the heat center.

8.4 STUDY OF IMPROVED TYPE B HHD

During the latter part of 1944 an improved model of the Type B HHD was constructed by Division 5, NDRC (the original designers of the Type B instrument), and tested early in 1945. AMP was requested to assist in the statistical analysis of data obtained in this experiment.

The performance of this improved device was evaluated in terms of the reliability of its production of direction signals in a 10° circle about the target when used at an altitude of 10,000 ft. The performance was found to be good for most of the targets considered. The experimental procedure used in the Division 5 tests was improved over that used in the earlier Bureau of Ordnance tests and the statistical analysis was accordingly modified. The essential changes in the new Type B tests were:

1. The FELIX eye and the camera which photographed the target area were synchronized and had the same field of view. On the BuOrd surveys a different person operated the camera and each HHD; hence, it was not possible to guarantee that the photographed area was actually the area at which a given HHD was directed.

2. Signal lights, which gave the HHD target indications, were photographed on the same film as the target area on the FELIX survey, while separate films were used on the BuOrd surveys.

3. The HHD and camera were moved only up and down on the BuOrd flights and were locked in azimuth; hence, only one crossover of the target area was obtained on a given run over the target. On the FELIX flights the operator repeatedly swept the camera (locked with FELIX) across the target both up-down and right-left on a given run. As a result of this latter innovation, much more information was collected on the relative stability of the HHD in indicating the target center. Also accurate data were then available on the actual lag in signaling. In order to utilize these data, the points of signal crossover (changing of lights from up to down, or right to left, or vice versa) were determined. The average center, the average variability of this center location, and the signal lag were easily determined for every target area surveyed.

In this experiment it was possible to estimate that the effect of the small signal delay (due to an electrical lag of 0.16 sec in the system) of the Type B HHD was about 3 frames of a 16-mm film. This created a corresponding small bias in the HHD's estimate of thermal center in the direction of flight over the target. Figure 3 shows graphically the effect of this signal lag. This figure represents the results of a laboratory calibration run in which the HHD was placed 15 ft above the heat source and was swept across the heat source from this fixed position. The coordinate system is in terms of screen units.

The details of the statistical analysis of the per-

formance of the improved Type B HHD have been reported in an AMP report.⁶ The principal results of the analysis may be summarized as follows.

1. Since the maximum area seen by the FELIX "eye" is approximately a circle on the ground of a 10° radius (e.g., at a 10,000-ft altitude, this radius

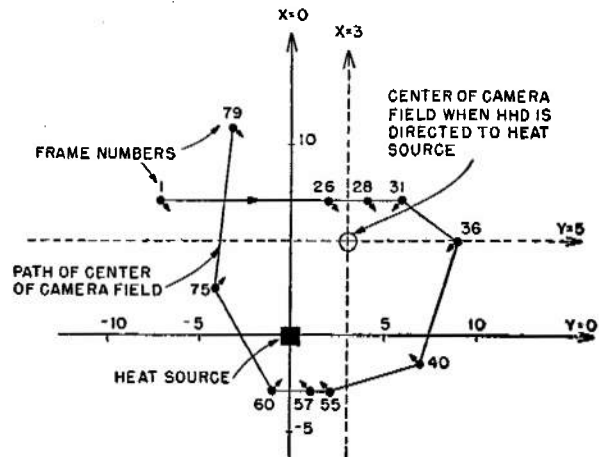

FIGURE 3. Target indications by FELIX when moved about a heat source.

The plotted path represents the course of the center of the field of the camera (and the Type B, which was locked to the camera). The arrows at the individual points of the path show the direction in which FELIX indicated the heat source. If there were no signal lags, the arrows should point towards the unshaded circle. The numbers at the points of the path are frame numbers when the film runs at the rate of 16 frames per sec.

would be about 1,750 ft), the success of the survey unit over a given target area was evaluated in terms of its operation within a 10° circle centered at the target center. For nine of the targets, the HHD was swept over the target areas in such a manner that the center of vision covered approximately a circular area of at least a 10° radius. Good results were obtained over five of the targets for a full 10° circle, over one target for a full 10° circle on six out of eight runs, and over two targets for a circle of somewhat less than the full 10° radius. Definitely bad results were obtained over one of these nine target areas. Over the other four target areas, the center of the HHD was swept over an area of less than a 10° radius. Correct target indications were obtained over all the area scanned for three of these targets, while good indications were given for a circle of only a 5° radius over the fourth target.

2. Overcast skies and snow on the ground tended to reduce the differential thermal effects between the target area and such areas as parking lots, cleared spaces, hillsides, and water.

3. Thermal differences between the target area and an adjacent water area were reversed at night unless the plant had much internal heat.

4. The variability of the HHD operation over a given target tended to be smaller if the background were relatively uniform, if the target consisted of one main building instead of several buildings, and if there were a large thermal differential between the target and the surrounding area. Also, of course, the signals are more consistent when the instrument is centered over a point near the thermal center of target.

5. There was insufficient data to make possible any general statements on the minimum thermal intensity necessary for successful HHD operation. However, successful daytime operation was obtained over one plant with a thermal intensity as low as 1.5 ergs per sq cm per sec.

6. The estimate of the center of a target area on a given run was generally slightly biased in the direction of flight over the target.

8.5 FURTHER POSSIBLE STATISTICAL STUDIES OF THE PERFORMANCE OF HHD'S

The experience of the AMP in the analysis of data regarding the performance of HHD's indicates that if further tests are carried out the following points, at least, should be considered.

1. Survey data are needed over such intense targets as steel mills and blast furnaces.

2. To further study the effect of fog and overcast sky, etc., more runs should be made over the same plant under varying weather conditions.

3. In tracking about a target, the instrument should be tracked counterclockwise part of the time. It was always tracked clockwise in the present surveys.

4. More information is needed on the effect of water near a factory area, especially as a function of time of day and sunlight.

5. The analysis of target areas could be much better applied to other targets if the radiation intensity were mapped over the region of the target.

Of course, final classification of targets with regard to their susceptibility to heat-homing devices must await actual bombing tests. In order to make such tests it seems necessary that radiation intensity maps of typical factory areas must be made and reproduced approximately for the bombing tests.

Also, the determination of the best lag must be done by means of experiments with actual bombs, since the adjustment of the lag in the bomb depends on the aerodynamic constants of the bomb itself (damping ratio and natural frequency). The lag of the survey unit was made small in the interests of convenience in film reading.

BIBLIOGRAPHY

Numbers such as AMP-11-M3 indicate that the document listed has been microfilmed and that its title appears in the microfilm index printed in a separate volume. For access to the index volume and to the microfilm, consult the Army or Navy agency listed on the reverse of the half-title page. The following abbreviations are used:

BuOrd	Bureau of Ordnance	AMP	Applied Mathematics Panel
SRG-P	Statistical Research Group—Princeton	SRG-C	Statistical Research Group—Columbia
BRG-C	Bombing Research Group—Columbia	AMG-P	Applied Mathematics Group—Princeton
AMG-C	Applied Mathematics Group—Columbia		

Summary

1. "Sequential Tests of Statistical Hypothesis," Abraham Wald, *The Annals of Mathematical Statistics*, Vol. XVI, No. 2, June 1945, pp. 117-186.
2. *Sequential Analysis of Statistical Data: Applications*, H. A. Freeman and Abraham Wald, prepared for AMP, Columbia University Press, Revised AMP Report 30.2R [OEMsr-618], SRG-C, Sept. 15, 1945. AMP-21.1-M4

Chapter 2

1. *Miscellaneous Probability Tables*, H. H. Germond, AMP Note 14, July 1944. AMP-11-M3
2. *Miscellaneous Probability and Statistical Tables and Graphs*, OEMsr-860, SRG-P 156, AMP Note 24, October 1945. AMP-11-M6
3. *Scatter Bombing of a Circular Target*, H. H. Germond and Cecil Hastings, Jr., OSRD 4572, OEMsr-818 and OEMsr-1007, BRG-C 120, AMG-C 302, AMP Report 10.2R, May 1944. AMP-803.4-M2
4. *Some Quantitative Information which Bears on the General Problem of Bombing Systems*. AMP Memorandum 11.13M, Sept. 30, 1943. AMP-806-M2
5. *Note on Determination of Aiming Points and Number of Bombs for Bombing Operations*, OSRD 5317, OEMsr-860, SRG-P 138, AMP Note 17, June 1945. AMP 806-M3
6. *Analytical and Statistical Studies of Certain Guided Missiles*, SRG-P 158, AMP Report 112.2R, October 1945, pp. 44-50. AMP-806-M4
7. *Air-to-Air Bombing, Memorandum No. 2 to Steering Committee for AC-92 from Sub-Committee on Bombing Effectiveness*, OEMsr-860, SRG-P 61, Sept. 23, 1944. AMP-803.5-M2
8. *Air-to-Air Bombing Probabilities for Three Types of Fuze*, OEMsr-1365, SRG-P 69, Oct. 26, 1944. AMP-704-M11

Chapter 3

1. *Preliminary Report on a Study of Train Bombing*, OSRD 1869, OEMsr-65, Service Project AC-27, Report to Services 33, Section D-2, Fire Control, NDRC, AMP Report 11.1R, Aug. 25, 1942. AMP-803.1-M1
2. *The Probabilities of Hitting, in Train Bombing, Rectangular Targets of Proportion One-by-Six or One-by-Nine*, OSRD 1278, Report to Services 53, Division 7, NDRC, AMP Report 11.3R, Mar. 10, 1943. AMP-803.1-M4
3. *The Theory of Multiple Hits on Multiple Targets in Train Bombing*, Appendices A and B, Jerzy Neyman, OSRD 1476, Report to Services 55, Division 7, NDRC, AMP Report 11.4R, May 10, 1943. AMP-803.1-M5
4. *Tables of Probabilities of at Least One, Two, Three, Four, and Five Hits on Rectangular Targets in Train Bombing*, OSRD 3882, OEMsr-818, BRG-C 108, AMP Report 11.10R, June 1944. AMP-803.1-M9
5. *Probabilities of at Least One, Two, Three, Four, and Five*

Hits on Rectangular Targets in Train Bombing when the Dispersion is Equal to the Target Width, OSRD 4644, OEMsr-818, BRG-C 122, AMP Report 11.13R, December 1944. AMP-801.1-M5

6. *The Character of the Train Bombing Probability Curve at the Point for Zero Spacing*, J. D. Williams, OEMsr-818, BRG-C 112, June 16, 1944. AMP-803.1-M10
7. *Note on the Direction of Attack with a Train of N Bombs when the Aiming Errors in Range and Deflection are Unequal*, Jan Schilt, OEMsr-818, BRG-C 116, July 1944. AMP-803.1-M11
8. *Train Bombing, Outline of Principal Results of Statistical Studies Conducted by the Applied Mathematics Panel*, OSRD 1784, AMP Report 11.5R, Aug. 12, 1943. AMP-803.1-M8
9. *An Empirical Verification of Tables on Multiple Hits*, Mark W. Eudey, OSRD 1810, OEMsr-817, AMP Report 11.7R, BRG-Statistical Laboratory, University of California, Aug. 10, 1943. AMP-801.2-M2
10. *Area Bombing Probabilities*, H. H. Germond, OSRD 4321, OEMsr-1007 and OEMsr-818, BRG-C 119, AMG-C 237, AMP Report 11.12R, July 1944. AMP-803.2-M4
11. *Note on Mission Planning Against an Important Target*, Jan Schilt, BRG-C 81, November 1943. AMP-801.1-M12
12. *Note on Mission Planning Against Multiple Targets*, Jan Schilt, OEMsr-818, BRG-C 82, November 1943. AMP-801.2M-4
13. *Note on Spacing for Group Attacks and Multiple Hits*, Jan Schilt, OEMsr-818, BRG-C 83, November 1943. AMP-801.2-M5
14. *Observations Concerning Multiple Attack and Multiple Hit Theory*, Jan Schilt, AMP Memorandum 11.12M, Columbia University, September 1943. AMP-801.2-M3
15. *Design of a Bomb Spacing Calculator*, H. H. Germond, OEMsr-818, (Rewrite of BRG 77), BRG 100, Apr. 26, 1944. AMP-801.3-M2
16. *Simplified Rule for Determining Spacing in Train Bombing on Stationary Targets*, Emma Lehmer, BRG 87, Statistical Laboratory, University of California, December 1943.
17. *A Study of the Seriousness of the Effects, in the Planning and Executing of Bombing Missions, of Mis-Estimates of the Standard Errors of Aiming and Dispersion*, OSRD 1149, Report to Services 46, Division 7, NDRC, AMP Report 11.2R, Jan. 12, 1943. AMP-803.1-M3
18. *On the Effects of Failing to Make a Correction of Trail in Train Bombing so as to Place the Center of Train on the Center of Target*, Evelyn Fix, OSRD 1800, AMP Report 11.6R, BRG-Statistical Laboratory, University of California, August 1943. AMP-803.1-M7
19. *Methods of Estimating Standard Errors of Aiming from Operational Data*, Jerzy Neyman, OSRD 3342, OEMsr-817, AMP Report 11.9R, BRG-Statistical Laboratory, University of California, January 1944. AMP-801.1-M3

20. *High Level and Medium Level Bridge Bombing*, R. I. Wolff, (Revised paper of BRG 105), BRG-C 115, AMP Memorandum 11.14M, July 1944. AMP-804.4-M2
21. *The Problem of Optimum Spacing in Low Altitude APQ-5 Train Bombing*, OEMsr-860, SRG-P 141, AMP Memorandum 11.15M, July 1945. AMP-803.3-M7
22. *Clearance of Paths Through Minefields by Aerial Bombing*, OSRD 6082, OEMsr-860, SRG-P 151, AMP Report 178.2R, August 1945. AMP-902-M4
23. *Proof that the Optimum Spacing for Sinking Probabilities is Independent of the Number of Attacks*, J. D. Williams, OEMsr-818, BRG-C 109, Feb. 6, 1944. AMP-804.2-M4
24. *Sinking Probabilities and Coefficients for at Least One Hit, at Least Two, etc.*, Jan Schilt, BRG-C 89, Dec. 27, 1943. AMP-804.2-M5
25. *Preliminary Report on Scatter Bombing*, H. H. Germond and Cecil Hastings, Jr., OSRD 904, Report to Services 34, Section D-2, Fire Control, NDRC, AMP Report 10.1R, September 1942. AMP-803.4-M1
26. *Scatter Bombing of a Circular Target*, H. H. Germond and Cecil Hastings, Jr., OSRD 4572, OEMsr-818 and OEMsr-1007, BRG-C 120, AMG-C 302, AMP Report 10.2R, May 1944. AMP-803.4-M2
27. *The Probability of at Least One Hit and the Average Number of Hits for Salvos with Various Dispersions Against Rectangular Targets*, OSRD 4804, OEMsr-818, BRG-C 123, AMP Report 10.3R, Jan. 1945. AMP-801.1-M6
28. *Air-to-Air Bombing, Memorandum No. 2 to Steering Committee for AC-92 From Sub-Committee on Bombing Effectiveness*, SRG-P 61, Sept. 23, 1944. AMP-803.5-M2
29. *Analytical and Statistical Studies of Certain Guided Missiles*, OEMsr-860, SRG-P 158, AMP Report 112.2R, October 1945, pp. 19-22. AMP-806-M4

Chapter 4

1. *Miscellaneous Probability and Statistical Tables and Graphs*, OEMsr-860, SRG-P 156, AMP Note 24, Oct. 1945. AMP-11-M6
2. *Analytical and Statistical Studies of Certain Guided Missiles*, OEMsr-860, SRG-P 158, AMP Report 112.2R, October 1945. AMP-806-M4
2a. *Ibid.*, pp. 50-63.
3. *Average Proportion of Hits on a Rectangular Target when Bombed by a Uniform Rectangular Pattern*, OEMsr-860 and OEMsr-618, SRG-P 96 and SRG-C 426, Jan. 22, 1945. AMP-801.1-M7
4. *Cooperative Study on Area Bombing*, Mark W. Eudey, Evelyn Fix, E. Lehman, D. H. Lehmer, Emma Lehmer, Jerzy Neyman, J. Robinson, M. Shane, and E. L. Scott, OEMsr-817, (Report submitted to AMP, NDRC), Statistical Laboratory, University of California, Oct. 1944. AMP-803.2-M3
5. *Distribution of the Percentage of Hits when Uniform Square Bomb Patterns are Dropped on Rectangular Targets*, OSRD 5212, OEMsr-860, SRG-P 119, AMP Report 184.1R, April 1945. AMP-803.2-M6
6. *A Coverage Problem Associated with Bombing*, OEMsr-860 SRG-P 157, AMP Report 173.1M, October 1945. AMP-803.2-M8
7. *Cooperative Study on Probability of Exploding Land Mines by Bombing*, Mark W. Eudey, Evelyn Fix, Emma Lehmer, Jerzy Neyman, and E. L. Scott, OEMsr-817, (Summary Report submitted to Division 2 and AMP, NDRC), Statistical Laboratory, University of California, April 1, 1944. AMP-902-M2
8. *Dependence of the Percentage of Hits on Pattern Area and Mean Radial Error, Derived from Operational Data on Formation Bombing*, OSRD 5416, OEMsr-860, SRG-P 130, AMP Report 174.1R, July 1945. AMP-803.2-M7
9. *An Empirical Determination of the Dependence of Pattern Area and Mean Radial Aiming Error on Certain Operating Factors in Formation Bombing*, OEMsr-860, SRG-P 159, AMP Report 174.2R, October 1945. AMP-803.2-M9
10. *Clearance of Paths Through Minefields by Aerial Bombing*, OSRD 6082, OEMsr-860, SRG-P 151, AMP Report 178.2R, August 1945. AMP-902-M4
11. *Attacks on a Maneuvering Target by a Small Number of Level Bombers*, J. D. Williams, OSRD 1905, AMP Report 11.8R, Columbia University, September 1943. AMP-804.4-M1
12. *A Photo-Electric Instrument for Rapid Bomb-Fall Analysis and Damage Prediction*, D. H. Lehmer, OSRD 5641, OEMsr-817, AMP Report 190.1R, University of California, May 1945. AMP-804.4-M4

Chapter 5

1. *Area Bombing Probabilities*, H. H. Germond, OSRD 4321, OEMsr-1007 and OEMsr-818, BRG-C 119, AMG-C 237, AMP Report 11.12R, July 1944. AMP-803.2-M4
2. *Miscellaneous Probability and Statistical Tables and Graphs*, OEMsr-860, SRG-P 156, AMP Note 24, October 1945, pp. 1-19. AMP-11-M6
3. *Scatter Bombing of Bomber Strips*, J. D. Williams, BRG-C 106, May 28, 1944. AMP-803.4-M3
4. *A Study of the Effectiveness of IB Aerial Attacks on German Industrial Targets, [Part] I. Probability of M47 Starting a Serious Fire in an Industrial Building*, E. W. Barankin, E. R. Dempster, and others, OEMsr-817, AMP Memorandum 190.1M, University of California, September 1945. AMP-804.3-M2
5. *A Study of the Effectiveness of IB Aerial Attacks on German Industrial Targets, [Part] II. Analysis of RAF Area Attack of 22/23 October 1943, on Kassel, with Special Reference to Effectiveness of the M50 Magnesium Bomb in Setting Fire to Industrial Buildings*, Evelyn Fix, OEMsr-817, AMP Memorandum 190.2M, University of California, September 1945. AMP-804.3-M3
6. *A Study of the Effectiveness of IB Aerial Attacks on German Industrial Targets, [Part] III. Summary Report on Fire Raising Effectiveness of Incendiary Bombs M47 and M50 Used Against German Industrial Targets*, Leo A. Aroian, E. W. Barankin, and others, OEMsr-817, AMP Memorandum 190.3M, University of California, September 1945. AMP-804.3-M4
7. *A New Vulnerability Equation in the Analysis of Incendiary Raids*, J. Bronowski and Jerzy Neyman, OSRD WA-3924-14, REN Report 471, Research and Experiment Dept., Ministry of Home Security, Great Britain, Dec. 1, 1944. AMP-804.1-M1
8. *Effect of Cluster Spacing on IB Densities in Area Attacks*, F. Garwood and J. Bronowski, OSRD II-5-5777(S), REN Report 372, Research and Experiment Dept., Ministry of Home Security, Great Britain, April 28, 1944. AMP-803.2-M1
9. *Bomb Damage*, Mary L. Shane, Progress Report 2, Feb. 16, 1945. AMP-804.4-M3
[A Stochastic Model of Incendiary Raids] Jerzy Neyman, Progress Report 3, Feb. 28, 1945. AMP-803.2-M5
[Distribution of Bombs] Progress Report 4, Mar. 9, 1945; AMP-801.1-M8
[Distribution of Bombs] Jerzy Neyman, Progress Report 5, Mar. 14, 1945. AMP-801.1-M9
Estimates of the Frequency Constants of the Distribution of Bombs, Jerzy Neyman, OEMsr-817, Service Project AN-

- 23, Progress Report 6, (Submitted to the Joint Target Group AC/AS Intelligency Hdqs. AAF), Statistical Laboratory, University of California, Mar. 20, 1945. AMP-801.1-M10
10. *The Effectiveness of Large Blast Bombs Against German Housing*, Jerzy Neyman, OEMsr-817, AMP Memorandum 190.4M, University of California, September 1945. AMP-804.3-M1

Chapter 6

1. *Optimum Angle off the Bow for Torpedo Attacks*, OEMsr-618, SRG-C 102, AMP Memorandum 71.2M, Nov. 1, 1943. AMP-405.2-M1
2. *Optimum Spread Angles for Destroyer Torpedo Salvos*, OSRD 3939, OEMsr-618, SRG-C 266, AMP Report 71.1R, July 1944. AMP-405.2-M2
3. *Torpedo Training Exercises*, Serial 1074, issued by Commander Destroyers, Pacific Fleet, Mar. 2, 1943.
4. *Efficient Paths for a Zig-Zag Torpedo*, OEMsr-618, SRG-C 338, AMP Report 105.1R, October 1944. AMP-405.5-M2
5. *Lead Angles for Aerial Torpedo Attacks Against Turning Ships*, OSRD 3867, OEMsr-618, SRG-C 190, AMP Report 8.1R, July 1944. AMP-405.1-M6
6. *Tables of Aircraft Torpedo Lead Angles*, OSRD 5097, OEMsr-618, SRG-C 453, AMP Report 8.2R, May 1945. AMP-405.1-M9

Chapter 7

1. *Expected Clearance of German and Japanese Antitank and Antipersonnel Mines by Explosive Mine Clearing Devices*, OEMsr-860, SRG-P 136, AMP Report 178.1R, June 1945. AMP-902-M3
2. *Curves Showing Expected Percent of Tanks which Will Cross Minefields without Striking Mines*, OEMsr-860, SRG-P 121a, AMP Memorandum 178.1M, April 1945. AMP-901.2-M1
3. *Expected Percent of Tanks Passing Through Minefields*

- without Striking Mines*, OEMsr-860, SRG-P 122, AMP Memorandum 178.2M, May 1945. AMP-901.2-M2
4. *Clearance of Mines by Rocket Barrages from the Woolfus*, OSRD 5640, SRG-P 150, AMP Report 161.1R, Aug. 1945. AMP-902-M5
 5. *Clearance of Paths Through Minefields by Aerial Bombing*, OSRD 6082, SRG-P 151, AMP Report 178.2R, Aug. 1945. AMP-902-M4
 6. *Cooperative Study on Probability of Exploding Land Mines by Bombing*, Mark W. Eudey, Evelyn Fix, Emma Lehmer, Jerzy Neyman, and E. L. Scott, OEMsr-817, (Summary Report submitted to Division 2 and AMP, NDRC), Statistical Laboratory, University of California, Apr. 1, 1944. AMP-902-M2

Chapter 8

1. *Analysis of Operation of Heat-Homing Devices during March, 1944*, First AMP Report on BuOrd Flight Project 70, SRG-P 38, AMP Report 127.1R, June 1944. AMP-805-M1
2. *Analysis of Operation of Heat-Homing Devices near St. Louis and Nashville on April 25, 1944*, Second AMP Report on BuOrd Flight Project 70, SRG-P 47, AMP Report 127.2R, August 1944. AMP-805-M2
3. *Analysis of Operation of Heat-Homing Devices during May, 1944*, BuOrd Flight Project 70, Report 3, SRG-P 59, AMP Report 127.3R, September 1944. AMP-805-M3
4. *Analysis of Operation of Heat-Homing Devices May 31 to June 24, 1944*, BuOrd Flight Project 70, Report 4, SRG-P 71, AMP Report 127.4R, November 1944. AMP-805-M4
5. *Analysis of Operation of Heat-Homing Devices after April, 1944*, BuOrd Flight Project 70, Report 5, SRG-P 92, AMP Report 127.5R, January 1945. AMP-805-M5
6. *Analysis of Operation of Felix Heat-Homing Device over Targets Near Boston, Massachusetts, during October 1944 and January 1945*, OSRD 5006, OEMsr-860, SRG-P 120, AMP Report 112.1R, April 1945. AMP-805-M6

OSRD APPOINTEES
APPLIED MATHEMATICS PANEL

Chief

WARREN WEAVER

Deputy Chief

THORNTON C. FRY

Acting Chief, May 29, 1945 to April 5, 1946

Technical Aides

B. H. COLVIN

H. H. GERMOND

CECIL HASTINGS, JR.

MYRTLE R. KELLINGTON

MARGARET S. PIEDERM

MINA S. REES

I. S. SOKOLNIKOFF

D. C. SPENCER

S. S. WILKS

J. D. WILLIAMS

Members

L. J. BRIGGS

R. COURANT

J. H. DELLINGER

G. C. EVANS

L. M. GRAVES

R. F. MEHL

H. M. MORSE

P. M. MORSE

H. P. ROBERTSON

A. H. TAUB

O. VEBLEN

CONTRACT NUMBERS, CONTRACTORS, AND SUBJECTS OF CONTRACTS FOR THE
APPLIED MATHEMATICS PANEL

<i>Contract Number</i>	<i>Name and Address of Contractor</i>	<i>Subject</i>
OEMsr-444	The Franklin Institute Philadelphia, Pa. Technical Representative, H. B. Allen	Computations.
OEMsr-618	Columbia University New York, N. Y. Official Investigator, H. Hotelling Director: W. Allen Wallis	Statistical methods applied to air combat analysis, torpedo tactics, acceptance inspection, research and development, and related problems.
OEMsr-817	University of California Berkeley, California Technical Representative, J. Neyman	Statistical analysis applied to bombing research concerned with problems of land mine clearance, the theory of pattern bombing and the bombing of maneuvering ships, and the theory of bomb damage.
OEMsr-818	Columbia University New York, N. Y. Technical Representative, J. Schilt	Mathematical and statistical studies of bombing problems; the application of IBM computing techniques to statistical problems in warfare analysis.
OEMsr-860	Princeton University Princeton, N. J. Technical Representative, S. S. Wilks	Statistical methods applied to miscellaneous problems in warfare analysis and to (1) verification of various long-range weather forecasting systems; (2) a study of fire effect tables and diagrams for warships; (3) bombing accuracy studies, analysis of guided missiles, and the performance of certain heat-homing devices; and (4) the clearance of mine fields by explosive devices.
OEMsr-944	New York University New York, N. Y. Technical Representative, R. Courant	Investigations in shock wave theory.
OEMsr-945	New York University New York, N. Y. Technical Representative, R. Courant	Research in problems of the dynamics of compressible gases, hydrodynamics, thermodynamics, acoustics, and related problems.
OEMsr-1007	Columbia University New York, N. Y. Technical Representatives, E. J. Moulton S. MaeLane A. Sard	Miscellaneous studies in mathematics applied to warfare analysis with emphasis upon aerial gunnery, studies of fire control equipment, and rocketry and toss bombing.
OEMsr-1066	Brown University Providence, R. I. Technical Representative, R. G. D. Richardson	Problems in classical dynamics and the mechanics of deformable media.
OEMsr-1111	Institute for Advanced Study Princeton, N. J. Technical Representative, John von Neumann	Studies of the potentialities of general-purpose computing equipment, and research in shock wave theory, with emphasis upon the use of machine computation.
OEMsr-1365	Princeton University Princeton, N. J. Technical Representative, Merrill M. Flood	Coordination of activities under Project AC-92 at the University of New Mexico, Carnegie Institution of Washington at Pasadena, Columbia University, and Brown University.

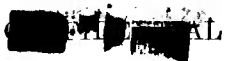

CONTRACT NUMBERS, CONTRACTORS, AND SUBJECTS OF CONTRACTS FOR THE
APPLIED MATHEMATICS PANEL (*Continued*)

<i>Contract Number</i>	<i>Name and Address of Contractor</i>	<i>Subject</i>
OEMsr-1379	Northwestern University Evanston, Ill. Technical Representatives, E. J. Moulton Walter Leighton	Studies in aerial gunnery, particularly the camera assessment of the performance of sights and of airplanes.
OEMsr-1381	Carnegie Institution of Washington Pasadena, Calif. Technical Representative, Walter S. Adams	Studies and experimental investigations in connection with the defensive fire power of various bomber formations by means of model planes with their guns replaced by suitable light sources, the total fire power being estimates of the light intensity.
OEMsr-1384	Harvard University Cambridge, Mass. Technical Representative, Garrett Birkhoff	Studies of the principles which determine the dynamic behavior of a projectile entering water and the application of these principles quantitatively to the prediction of under-water trajectories and ricochet.
OEMsr-1390	The University of New Mexico Albuquerque, N. M. Technical Representative, E. J. Workman	Studies and experimental investigations in collaboration with the Army Air Forces of the most effective formations and flight procedures for the B-29 airplane. Emphasis, originally upon the tactical use of the B-29, was later changed to a study of the defense of the B-29.
Transfer of Funds	National Bureau of Standards	Computations by the Mathematical Tables Project for various agencies concerned with war research.

SERVICE PROJECT NUMBERS

The projects listed below were transmitted to the Office of the Executive Secretary, OSRD, from the War or Navy Department through either the War Department Liaison Officer for NDRC or the Office of Research and Inventions (formerly the Coordinator of Research and Development), Navy Department.

*Service
Project Number*

Subject

ARMY PROJECTS

AC-27 Design data for bombardier's calculator.
AC-91 Statistical problems of combat bombing accuracy.
AC-92 Collaboration of the NDRC with the AAF in determining the most effective tactical application of the B-29 airplane (continuing under AAF Proving Ground Command, Fire Power Analysis Project).
AC-95 Analysis of Waller trainer film.
AC-109 Textbook on flexible gunnery.
AC-115 Study of data accumulated in sight evaluation tests.
AC-122 Study of gun camera film scoring in order to devise a scoring computer.
AN-23 Studies of HE-IB attack on precision target.
CE-33 Checking of hydraulic tables.
OD-143 Study of fuze dead-time correction in AA director.
OD-179 Statistical assistance in rocket propellant tests and specifications.
OD-181 Study of relative destructive effect of machine gun fire against airplane structures.
QMC-35 Food storage data statistics.
QMC-38 Studies of various statistical problems encountered at the Climatic Research Laboratory.
QMC-43 Statistical consultation for Quartermaster Corps inspection service.
SC-81 Rapid solution of linear equations with up to twenty-six unknowns.
SC-100 Binomial distribution calculations.
SOS-2 Probability theory of balloon barrages.

NAVY PROJECTS

N-110 Mathematical studies of lead-computing sights for use with gunnery training.
N-112 Study and evaluation of sighting methods of instruction used in U. S. Naval Aviation free gunnery training.
N-120 Preparation of instruction course for quality control and statistically based sampling procedures.
NA-167 Study of nozzle design for jet motors.
NA-177 An analytical method of determining ships' speeds in turns from photographs of ships' wakes.
NA-195 Study of jet propulsion devices operating at subsonic and supersonic velocities (continuing under Contract NOa(s)-7370).
ND-2 Assistance to the Air Technical Division—studies of aircraft weapon effectiveness.
NO-108 Probability and statistical study of plane-to-plane fire.
NO-130 Air testing of Mark 15 bombsight.
NO-131 Probability studies desired in connection with estimating hits made by close-range AA gun fire at head-on airplane targets.
NO-136 Mathematical studies of dive-bomber and bomb trajectories in connection with Alkan dive-bombsight.
NO-145 Mathematical studies of bombing.
NO-145 Ext. Train probability calculations for bombing, November 1944.
NO-145 Ext. Probability curves for use in connection with gunnery salvo fire, June 1945.
NO-158 Antitorpedo-harbor defense nets.
NO-161 Theoretical studies of water entry phenomena (continuing under Contract NOa(s)-7370 with New York University and under Navy Contract with Harvard University).
NO-188 Study of torpedo spreads and their use against maneuvering targets.
NO-206 Studies of acceptance tests on ordnance material.
NO-237 Determination of depth of underwater explosions from surface observations (continuing under Contract NOa(s)-7370).

SERVICE PROJECT NUMBERS (Continued)

<i>Service Project Number</i>	<i>Subject</i>
NO-261	Statistical analysis of the data on thermal characteristics of targets and the relative performance of candidate heat-homing equipment.
NO-264	Gun equilibrators.
NO-269	B-scan radar plotting device.
NO-270	Computation services (continuing under a transfer of funds from the Office of Research and Inventions to the Bureau of Standards).
NO-272	Computation of dynamic performance of AA computer (continuing under Contract NOrd-9153).
NO-280	Statistical assistance in rocket propellant tests and specifications.
NO-294	Study of tactical utilization of offset guns in fighter aircraft.
NR-101	Probability study of a proposed type of antiaircraft projectile.
NR-105	Fire effect tables (continuing under Contract NOrd-9240).
NS-165	Nonlinear mechanics.
NS-166	Gas globe phenomena in underwater explosions.
NS-302	High-temperature metals.
NS-364	Investigation of wave patterns created by surface vessels (continuing under Contract NOa(s)-7370).

INDEX

The subject indexes of all STR volumes are combined in a master index printed in a separate volume. For access to the index volume consult the Army or Navy Agency listed on the reverse of the half-title page.

- Aerial bombing, minefield clearance, 84-87
 conclusions, 86
 early experiments, 86-87
 statistical method of analysis, 86
- Aiming error distribution, 11-12, 23
- Aiming error estimates, train-bombing
 combat data estimates, 39
 effect of misestimates on efficiency, 37
 misestimates, 37-39
- Aircraft allocation, large-scale bombing, 29-30
- Aircraft torpedo attacks on warships, 76-78
- Air-to-air bombing
 high attack from rear, 22
 low level frontal attack, 22
 scatter-bombing, 44-45
- AMP, NDRC, summary of work, 1-6
- Angle of attack, train-bombing, 24
- Antitank mine clearance by linear explosive devices, 79-82
- Applied Mathematics Panel, NDRC, summary of work, 1-6
- APQ-5 radar bombsight used in ship-bombing, 40, 41
- AZON (guided missile)
 pattern-bombing, 53-54
 probability of hits, 45
 probability study, 21-22
 scatter-bombing, 44-45
- Ballistic Res. Lab., Aberdeen Proving Ground, train-bombing probability, 24
- Bangalore torpedo (mine clearance device), 79
- Beach minefield clearance by rocket barrages, 83-84
- Blast bombs, mean area of effectiveness, 64-65
- Bomb fall, definition, 9
- Bomb patterns, uniform, 50-51
- Bombing, statistical studies, 58-62, 64-65
see also Probability of hitting targets *a priori* and *a posteriori* investigations, 12
 aiming error distribution, 11-12, 23
 choice of criterion, 9-10
 dispersion error distribution, 23
 mean area of effectiveness, large blast bombs, 64-65
 models used for calculations, 10-11, 58
 probability of hitting target sections, 58-62
 terminology and notation, 12-13
- Bombing methods
 aerial bombing for minefield clearance, 84-87
 air-to-air bombing, 22
 distinction between high- and low-altitude bombing, 39
 heat bombing, 88-92
 incendiary bomb attacks, 62-64
 pattern bombing, 46-57
 scatter bombing, 41-45
 single-release bombing, 14-22
 train-bombing, 23-45
- Bombing probability slide rules
 area-bombing, 60
 bomb-spacing, circular slide rule, 31-34
 multiple-attack bombing, 35-36
 small-target bombing, 18, 60
- Bomb-spacing rules, train-bombing, 31-35
 aiming-error statistic, 34
 bomb-dispersion statistic, 34
 calculator for optimum spacing, 31-34
- Bridge-bombing, 39-41
- British combat bombing operations, 23
- Carpet roll (minefield clearance device), 79
- Cell diagram, graphical estimation of probability in bombing, 16-17
- Circular probable error (CEP) in bombing statistics, 13, 18
- Circular targets, probability of hitting, 14
- Crater effect, mine explosions, 82
- Demolition snakes (antitank minefield clearance device), 79-82
- Detonating cable (antipersonnel minefield clearance device), 79
- Dispersion-error distribution, definition, 23
- Elliptical targets, probability of hitting, 14
- Expected number of hits, bombing studies criterion, 10
- Explosive pressure gauge, universal indicator mine, 79-82
- Felix (VB-6) heat-homing bomb, 91
- Fire control errors, standard deviation, 72
- "Fire division" (vulnerability of buildings to fire), 62-64
- Gauge for explosive pressure, universal indicator mine, 79-82
- Gaussian distribution, bombing statistics, 11-12
- Guided missile AZON
see AZON (guided missile)
- Guided missile Razon, aiming point selection, 20
- Heat-homing devices, statistical analysis, 88-92
 conclusions, 90
 experimental set-up, 88
 Farrand instrument for thermal measurement, 88
 Felix bomb eye, 91
 improved type B device, 90-92
 problem, 88
 reliability of target signals, 90
 research recommendations, 92
- Hit probability
see Probability equations; Probability of hitting targets
- IBM equipment used in train-bombing probability calculations, 24
- Incendiary bomb attacks, 62-64
 "fire division" categories, 63
 M-47 bomb performance, 64
 M-50 bomb performance, 63, 64
 vulnerability of buildings to fire, 62-64
- Lead angles for aircraft torpedo attacks on maneuvering warships, 76-78
 essential problem, 76
 formulae, 77-78
 numerical conditions, 76
- Linear explosive devices for minefield clearance, 79-83
 Bangalore torpedo, 79
 crater effect, 82
 curves of expected percentage of detonation, 82-83
 problem, 79
 skip effect, 82
 universal indicator mine, 79-82
- M-1 Snake (antipersonnel minefield clearance device), 79
- M-47 incendiary bomb, 64
- M-50, incendiary bomb, 64
- MAE (mean area of effectiveness), large blast bombs, 64-65
- Mark XXVII torpedo director, 69
- Mine clearance, statistical studies, 79-87
 aerial bombing, 84-87
 general discussion, 39-41
 linear explosive devices, 79-83
 pattern bombing, 54
 rocket barrages, 79, 83-84
- MPI (mean point of impact), bombing, 11-12
- MRE (mean radial aiming error) bombing, 13
- Multiple attack train-bombing, probability, 28-31
- Offset, effect of mis-aiming, 36, 37
- Path clearance through mine fields, 84-87
- Pattern-bombing, 46-57
 average proportion of hits, 46-47

- controlled-missile patterns, 53
 probabilities determined from operational reports, 51-53
 probability of hits, 47-49
 probability of target coverage, 48-49
 regression equations, 53
 scatter-bombing, 41-45
 uniform bomb patterns, 50-51
- Pattern-bombing, synthetic patterns, 54-57
 maneuvering targets, 54-55
 mine field clearance, 54
 photoelectric analyzer, 56-57
- Probability equations
 average proportion of hits, pattern bombing, 46-47
 circular target coverage, scatter bombing, 42
 density, aiming error distribution, 11-12
 density, radial error distribution, 20
 expected hits on target, 10
 mean effective area, given bomb type, 65
 probability of at least n hits, 10
 probability of at least n hits, multiple attack train-bombing, 28, 49-50
 probability of hitting target with single bomb, 14
 proportion of target coverage, uniform patterns, 49
 ship sinking, 41
 standard deviation, fire control errors, 72
 statistically uniform distributed target area, probability of hits, 58-61
 torpedo salvo hits, 70-71
- Probability of hitting target with single bomb, 14-18
 approximations of probability, 15-16
 circular probable error, 18
 graphical estimation cell diagram, 16-17
 slide rule for computing probability, 18
 target areas, 14-15
- Probability of hitting targets, multiple attack train-bombing, 28-31
 aircraft allocation, 29-30
 calculations, 28
 conditions calculated, 28
 individual bomber effectiveness, 31
 optimum hits per aircraft lifetime, 32
 optimum number of aircraft per attack, 30-31
 slide rule, 35-36
- Probability of hitting targets, single attack train-bombing, 24-27
 angle of attack, 24
 maximum probability, 26
 optimum spacing, 24-25, 27
- RAZON (guided missile), aiming point selection, 20
- Rectangular targets, probability of hitting, 14
- Regression equations, pattern bombing statistics, 52-53
- Research recommendations for heat-homing devices, 92
- Right-triangle targets, 14
- Rocket barrages, beach mine field clearance, 79, 83-84
 factors determining effectiveness, 84
 probability of clearance with given number of barrages, 84
 rocket launching device, 83-84
- Saturation bombing, 58
- Saw-tooth zigzag torpedo path, 74-78
- Scatter-bombing, 41-45
 applications, 44-45
 theory, 41
- Serpentine torpedo path, 74-76
- Ship maneuverability in turns, 76
- Ship-bombing, 39-41
 hitting of ships, 41
 sinking of ships, 41
- Single attack train-bombing, probability, 24-27
- Single-release bombing, 14-22
 aiming point selection, 18-21
 air-to-air bombing, 22
 application, 14
 imitation of combat errors, 20-21
 improvement of target coverage, 18-20
 laterally controlled missile, AZON, 21-22
 probability of hitting target, 14-18
- Skip effect, mine explosion, 82
- Slide rules for computing bombing probabilities
 area-bombing, 60
 bomb-spacing, circular slide rule, 31-34
 multiple-attack bombing, 35-36
 small-target bombing, 18, 60
- Spacing bombs in train-bombing, 24-27, 31-35
- Spread angles for torpedo salvos
see Torpedo salvos, spread angle
- Standard deviation
 aiming error, 11, 13
 bomb dispersion, 13
 fire control errors, 72
- Synthetic bomb patterns, 54-57
- Target areas, hit probabilities, 14
- Target in statistical studies, definition, 9
- Taylor Model Basin, maneuverability characteristics of ships, 76
- Torpedo attacks on maneuverable targets, 76-78
- Torpedo bombing, statistical studies
 lead angles for aircraft attacks on maneuvering warships, 76-78
 single-release bombing, 14
 terminology, 69
 torpedo salvos, spread angle, 69-73
 zigzag torpedo effectiveness, 73-76
- Torpedo salvos, spread angle, 69-73
 computational results, 72-73
 conclusion from studies, 73
 considerations affecting angle, 69-70
 probability of getting hits, 70-71
 problem, 69
 standard deviation of fire control errors, 72
- Train-bombing, 23-45
 aiming-error distribution, 23
 applications of theory, 39-41
 bomb spacing rules, 31-35
 dispersion-error distribution, 23
 efficiency compared with other bombing methods, 36-37
 equipment problems, 23
 problem analysis, 23
 scatter-bombing, 41-45
- Train-bombing, applications, 39-41
 bridge bombing, 39-41
 mine fields, 39-41
 ships, hitting, 39-41
 ships, sinking, 39-41
- Train-bombing, probability, 24-31, 34-39
 aiming errors estimated from combat data, 37, 39
 comparison with other bombing methods, 36
 efficiency, 36-37
 mis-estimates of aiming-error, 37-39
 number of attacks necessary for maximum probability, 37
 offset, 36-37
 probabilities of hitting targets with multiple attacks, 28-31
 probabilities of hitting targets with single attacks, 24-27
 rules for determining probability, 34-36
- Universal indicator mine (gauging device for explosive pressure), 79-82
- VB-6 (Felix) heat-homing bomb, 91
- Woofus, rocket launching device, 83-84
- Zigzag torpedo, effectiveness, 73-76
 numerical data, 73
 problem, 73
 saw-tooth torpedo path, 74-76
 serpentine torpedo path, 74-76
 unrestricted torpedo course, 73-76

FORM 88-B (18 MAR 47)		CONFIDENTIAL		C-22-8-5		ATI- 12116	
National Defense Research Committee		DIVISION: Ordnance and Armament (22)		SECTION: Bombing Systems (4)		ORIG. AGENCY NUMBER	
AUTHOR(S)		AMER. TITLE: Bombing studies		FORG'N. TITLE:		REVISION	
ORIGINATING AGENCY: O.S.R.D., N.D.R.C., Washington, D. C.							
TRANSLATION:							
COUNTRY	LANGUAGE	FORG'N. CLASS	U. S. CLASS.	DATE	PAGES	ILLUS.	FEATURES
U.S.	Eng.		Conf'd'l	1946	78	71	photos, tables, diagrs, graphs
ABSTRACT							
Principal results of probability and statistical studies of various bombing problems are presented. Types of bombing covered are single-release bombing, train bombing, scatter bombing, and pattern bombing. Rules for bomb spacing and for determining probabilities of hitting are given. Principal bombing tactic used by U.S. medium heavy and very heavy bombers during World War II was pattern bombing. This type of bombing employed almost simultaneous release of all bombs carried by a formation of aircraft.							
T-2, HQ, AIR MATERIEL COMMAND		AIR TECH CONFIDENTIAL		WRIGHT FIELD, OHIO, USAAF WF-O-31 MAR 47 15M			

ATI-12115, ATI-12116, ATI-12117

*Confidential to
Unclassified per auth:
Sec of Def memo, 2 Aug 60*

AD-B809 137

FORM 88-B (18 MAR 47)		CONFIDENTIAL		C-22-9-8		ATI- 12117	
National Defense Research Committee		DIVISION: Ordnance and Armament (22)		SECTION: Torpedoes and Mines (4)		ORIG. AGENCY NUMBER	
AUTHOR(S)		AMER. TITLE: Miscellaneous studies		FORG'N. TITLE:		REVISION	
ORIGINATING AGENCY: O.S.R.D., N.D.R.C., Washington, D. C.							
TRANSLATION:							
COUNTRY	LANGUAGE	FORG'N. CLASS	U. S. CLASS.	DATE	PAGES	ILLUS.	FEATURES
U.S.	Eng.		Conf'd'l	1946	33	16	photo, table, diagrs, graphs
ABSTRACT							
Three substantial analytical and statistical studies on miscellaneous problems of increasing tactical effectiveness of torpedoes are presented. Studies were made to determine optimum spread angles for salvos of torpedoes launched from destroyers for various ranges, target angles, number of torpedoes per salvo, comparing effectiveness of submarine-launched torpedo which would zigzag across target with straight-course torpedo, and computation of lead angles for aerial torpedo attacks against maneuvering ships.							
T-2, HQ, AIR MATERIEL COMMAND		AIR TECH CONFIDENTIAL		WRIGHT FIELD, OHIO, USAAF WF-O-31 MAR 47 15M			

TITLE: Probability and Statistical Studies in Warfare Analysis - Vol III		CONFIDENTIAL		C-24-6-8		ATI- 12115	
AUTHOR(S) : (Not known)		ORIG. AGENCY : Office of Scientific Research and Development, Washington, D. C.		PUBLISHED BY : (Same)		REVISION : (None)	
DATE : 1946		DOC. CLASS. : Conf'd'l		COUNTRY : U.S.		LANGUAGE : English	
PAGES : 118		ILLUSTRATIONS : photos, tables, diagrs, graphs		ABSTRACT:			
<i>Bound Together</i>							
Summary of principal results of a portion of probability and statistical investigations made by Applied Mathematics Panel during World War II. Investigations include statistical studies of various bombing problems, summary of principal results of probability and statistical aspects of three (torpedo) studies, three mine clearance investigations, and an extensive study of performance of heat-homing devices.							
DISTRIBUTION: Copies of this report obtainable from CADO.							
DIVISION: Military Operations (24)				SECTION: Strategy and Tactics (6)			
SUBJECT HEADINGS: Warfare, Aerial (97720); Bombing systems (16681.18); Torpedoes, Aerial (94525); Torpedoes, Naval (94535); Target seekers (91900)				ATI SHEET NO.: C-24-6-8			
Central Air Documents Office Wright-Patterson Air Force Base, Dayton, Ohio				AIR TECHNICAL INDEX CONFIDENTIAL			