

749
NACA TM No. 1210

7871

NATIONAL ADVISORY COMMITTEE FOR AERONAUTICS

TECHNICAL MEMORANDUM

No. 1210

DEVELOPMENT OF SPOILER CONTROLS FOR REMOTE
CONTROL OF FLYING MISSILES

By G. Ernst and M. Kramer

Translation of ZWB Forschungsbericht Nr. 1717, January 1943



Washington

March 1949

AFMEO
TECHNICAL LIBRARY
APL 2511

0144647



TECH LIBRARY KAFB, NM



NATIONAL ADVISORY COMMITTEE FOR AERONAUTICS

TECHNICAL MEMORANDUM NO. 1210

DEVELOPMENT OF SPOILER CONTROLS FOR REMOTE
CONTROL OF FLYING MISSILES*

By G. Ernst and M. Kramer

SUMMARY

The present report deals with the aerodynamic, constructive, and instrumental development of a spoiler control for remote control of flying missiles.

I. INTRODUCTION

The mode of operation of the spoiler control consists, in principle, of inducing separation of flow at an appropriate point of the airfoil by a controllable spoiler and through it introduces a variation in the lift, hence a control effect. The spoiler control has become known through the attempts to remove the defects of the normal aileron control of airplanes. (See references 1, 2, and 3.) As simple and convincing as the spoiler principle appears at first, a number of difficulties were encountered during the development of a spoiler aileron control for normal airplanes, which up to now prevented its practical application.

In the remote control of flying missiles, such as bombs, special conditions are involved, which again posed the question whether or not a spoiler control would offer any advantage over the control with conventional control surfaces. Attractive characteristics of the spoiler are, in principle, its low power requirement and its low inertia, both of which rest on the fact that, compared to the conventional control surfaces, only very small masses (hinged spoilers) need to be actuated which can be easily designed with neutral aerodynamic balance.

*"Entwicklung der Unterbrechersteuerung für ferngesteuerte Flugkörper." Zentrale für wissenschaftliches Berichtswesen der Luftfahrtforschung des Generalluftzeugmeisters (ZWB) Berlin-Adlershof, Forschungsbericht Nr. 1717, January 6, 1943.

Once a practically inertia-free control of low power requirement is available, substantial technical simplifications, particularly in connection with remotely controlled flying missiles, are possible, which collectively have a beneficial effect on the space required, the weight, the costs and the operational safety of the control. Practice demands simple and robust devices. Hence, the attempts of the DVL to develop a spoiler control suitable for remotely controlled flying missiles.

The aerodynamic and structural development of a spoiler control element up to its present stage is described and its possible application discussed.

II. AERODYNAMIC DEVELOPMENT

From the very first it was clear that the difficulties of the development and the completion of a new type of control had to be simplified by reason of the fact that an over-all design of the flying missile was chosen so that the same control element could be uniformly utilized for the control about all three axes, so that no separate development for aileron, elevator, and rudder was required. The result was a tail-unit structure of the missile as shown in figure 1, consisting of six identical control elements. To prevent interference effects and also to suppress the angle-of-yaw effect, the control elements were, at first, fitted with end plates.

Known up to then was the mounting of a spoiler on the upper surface of the wing at about 43 percent of the chord (fig. 3(a)). This arrangement ensures adequate spoiler effectiveness at high angles of attack, but unsatisfactory at low angles. Since the angles of attack at the tail unit are small because of the downwash of the wings, and because constant effectiveness of control in the positive and negative range of angles is imperative, a thick symmetrical profile was chosen first for the control element (25 percent thick with the maximum thickness at 40 percent of the chord) and a spoiler provided on the upper and lower surface (figs. 3(b) and 14). Tests established the position of the spoiler of maximum efficiency at about 50 percent of the wing chord. In view of construction difficulties only one spoiler width, 50 percent of the control element span, was chosen at first.

The fundamental behavior of such a spoiler is indicated in figure 2. It is seen how up to a certain spoiler height the spoiler is ineffective (boundary-layer effect) and frequently even produces a slight counter effect following a steep rise

in action until, after complete breakdown of flow, the effect of a further increase in spoiler height is small. The height at which practically full aerodynamic action is attained, is hereinafter termed the "required spoiler height" and the height at which no positive action occurs yet, the "permissible spoiler height."

The spoiler paths required proved themselves too great for the arrangement of figure 3(a) and for electrical operation; that is, the power required and the inertia of the spoiler did not yet permit the subsequently described extremely simple remote control design. At this stage of development the following reflection resulted in some progress (Fig. 3(c)): by connecting the spoilers of both profile sides and letting them in rest position extend the profile by the permissible spoiler height plus half the spoiler path, it yields for each magnet only half the lift, that is, at least a doubled rating factor

$$W = \frac{\Delta c_a K}{U L}$$

- Δc_a aerodynamic action of the spoiler
- K actuating force of spoiler
- U change-over period at sudden change of command
- L power input of driving unit

The improvement is secured by an increase in aerodynamic resistance at neutral spoiler setting, hence, applicable only where the drag of the control is unimportant (reference 4).

If the development had involved a control element for normal flying speeds only, then the arrangement of figure 3(c) would have given satisfactory results, since it afforded practically useful spoiler paths even at low Mach numbers ($M < 0.6$). But the design problem on which the control was to be used called for a speed range starting at $M \approx 0.3$ and ultimately extending beyond sonic velocity. Experiments at high flow velocity disclosed a relationship between the required and the permissible spoiler height and the Mach number in the sense that both values decrease at high Mach numbers; that is, less height is necessary at high Mach numbers to secure complete separation of flow, but also only a lesser spoiler height is permissible, if no disturbance is to occur. This relationship is shown in figure 4 on the basis of test data. Figure 4 also shows the critical Mach number at which the flow, even without

spoiler, breaks away from the rear portion of the profile, hence, where the control fails for aerodynamic reasons.

At this stage a way to remove these difficulties was found in the aerodynamic fixing of the body design. The consideration initiating this improvement rested on the observation that even at the highest Mach number involved for the particular profile small spoiler heights were still consistently overcome without disturbance. Accordingly, it had to be possible to increase the permissible, that is, nondisturbing spoiler height (in terms of the original profile contour), when the spoiler is faired in neutral position, that is, given an aerodynamically beneficial profile step at the spoiler location (fig. 3(d)). Such a profile step protruding in the highest point of the step was bound to make the spoiler more efficient because it lowers the thickness of the boundary layer and produces a higher increase of speed. The only problem was to find the height of this step without inducing separation at the highest Mach numbers permissible for the particular profile. Figure 5 represents the result for the best step adapted to this profile. Comparison of the results, with and without step, discloses the marked improvement secured by the step (fig. 6). The required spoiler path was reduced to about one third of the value without step (reference 5).

Aside from the principal improvement of the spoiler the usual means for reducing the Mach effect - such as reducing profile thickness and camber - were tested step by step and adapted to the spoiler requirements. Thus the original profile thickness of 25 percent with 40 percent chord location of maximum thickness was modified by an extension in a 16.6-percent-profile maximum thickness at 60 percent of the chord, the profile camber near the trailing edge being removed by appropriately increased trailing-edge thickness (fig. 7). Figures 4, 5, and 6 indicate measurements with this profile. The increase in trailing-edge thickness is involved only where the additional resistance of the control plays no part. Elsewhere the thickening up of the trailing edge must be replaced by an increase in profile chord.

It took a number of preliminary tests to find a suitable shape of the swept-back control element. At first the element was swept back as a whole (fig. 8) and it was found that the sweepback makes the spoiler very quickly ineffective. At 30° sweepback of the total fin, the span of spoiler had to be doubled and the deflection increased by 50 percent to come anywhere near the effect of the original element. At 45° sweepback no appreciable action is attainable even with doubled deflection. Any hope of worthwhile increase in the critical Mach number based on the sweepback was abandoned.

Faced by these facts, the fin design (fig. 9), was chosen; the leading edge had a 45° sweepback. The end disk in the forward portion of the profile was removed and the outer edge suitably rounded off. The then unrestricted lateral flow-off together with the 45° swept-back leading edge and the additional decrease in profile thickness of the inner part produced favorable approach flow conditions. But as the required critical Mach number could still not be reached with this arrangement, the trailing edge was thickened up more and so the fundamental behavior of figure 10 ascertained; that is, a thick trailing edge promises adequate spoiler effectiveness beyond the test range (subsonic wind tunnels permit measurements only up to $M \approx 0.9$), a thin trailing edge sufficient effectiveness within the range of measurement. The same holds for a corresponding variation of the height of the step (fig. 11) although not to the same extent. The next stage of development involved the steady variation of the trailing-edge thickness and the step height within the span of the control element, which yield a practical control characteristic for high and low Mach numbers, since the characteristic of the different profiles is superposed. As the superposition is at the expense of control element action, it may not be pushed beyond the requirements for design accuracy and reaction time of the particular missile. Figure 12 presents the result of a measurement on a control element with continuously varying trailing-edge thickness and height of step. Comparison with figure 6 discloses the extension of the practical speed range at the expense of the action (reference 6).

In the measurements represented in figures 4, 5, 6, 10, 11, and 12, the spoiler was reproduced by superimposed angles. The effect of the slot necessary for the exit of the spoiler from the profile contour is indicated in figure 13. It is seen that the slot smoothes the action curves, that is, the action peak occurring at certain Mach numbers is moderated and a practically more useful characteristic is attained.

The measurements for the figures 4, 5, 6, 10, 11, 12, 13, and 24 are reproduced only for angle of attack $\alpha = 0^\circ$, since the heavy demands on the high-speed tunnel of the DVL permitted no systematic variation over the angle-of-attack range. Sampling at $\alpha = 3^\circ$ and $\alpha = 5^\circ$ disclosed no appreciable relation between spoiler action and angle of attack.

A control element designed on this basis was flight-tested (two flight tests) and proved satisfactory beyond the test range of the high-speed tunnel up to the terminal velocity of 335 meters per second reached thus far, that is, up to a Mach number of 0.98.

III. CONSTRUCTION OF SPOILER ELEMENT

Figure 14 represents a sectional drawing of the spoiler tendered by the DVL in 1939 to a manufacturer for a missile of 1500 kilograms total weight; figure 15 shows the corresponding control elements according to the state of development at that time.

The element (fig. 16) consists in both cases of two bell-shaped magnets and the oscillating armature between the magnets, the casing, and the elastically supported parallel linkage. All moving parts were designed for minimum weight. In the first version the spoiler casing stamped from 0.5 millimeter sheet iron. The safe loading of the spoiler plate was 10 kilograms. The total weight of the moving parts amounted to about 50 grams. For a spoiler path of ± 3 millimeters this element changes over from complete deflection of one side to the other in about 1/100 second, provided that magnetic lag is avoided by appropriately designed magnetic circuit. The power input required is 5 watts, and the smallest magnetic elevator force, 0.3 kilogram. The spoiler is aerodynamically indifferent; that is, there is no measureable variation of the actuating force of the spoiler by aerodynamic forces within a dynamic pressure range of 0 to 5000 kilograms per meter².

Essential was the problem of the necessary actuating force which defines the power input required for given spoiler path. Since no difficulties are involved in the design of an aerodynamically indifferent spoiler, it requires, in principle, only the magnetic force which safely overcomes the elastic restoring forces of the frictionless parallel linkage. The rigidity of the elastic parallel linkage itself is governed largely by the change-over period required and the elevator masses.

The first version (fig. 16) was developed from these points of view. That is, it was aerodynamically neutral; the parallel linkage avoided every bearing friction; a hot-air heating system exhausting at the spoiler slots prevented icing and penetration of foreign objects within certain limits; and the magnetic elevator force of 0.3 kilogram minimum value was safely able to overcome the elastic forces of the parallel linkage.

Although extensive flight testing of this control element has so far given no occasion for it, it may be objected that penetrating dirt might cause the spoiler to stick or at least impede its freedom of movement. The DVL has therefore checked the ways in which the operating safety of the spoiler can be

enhanced against fouling without vitiating the other, already attained performances. One possibility consists in improving the magnetic system of the spoiler by changing from flat to dipping armature (fig. 17). Under otherwise identical assumptions the ratio of actuating force to power required can be raised by about four times the value.

But an increase in elevator force alone is not capable of preventing an obstruction of the spoiler through penetrating dirt; therefore the DVL checked this problem from the constructive side and reached the solution represented in figure 18. In this constructive solution the edges of the profile step, between which the spoiler moves at about 1 millimeter clearance, are designed comblike of elastic material, through which a sticking of the elevator due to penetration of foreign bodies is prevented. The design of the teeth of the elastic comb ensures adequate rigidity relative to the applied air loads. Figure 18 also shows an originally not provided housing of the magnet slots. Penetrating dirt can thus not obstruct the magnet armature and cause sticking at the spoiler slots. Since the elastic support of the elevator was from the very first insensitive to dirt, all sensitive points of the spoiler are thus protected and the danger to operating safety due to dirt is precluded. (See reference 7.)

Considering that the weight of the moving parts can still be considerably decreased by the use of light alloys and in the latest version the spoiler path was lowered from ± 3 millimeters to ± 2 millimeters, it seems entirely possible to design a spoiler element of the described order of magnitude with 1-watt to 2-watt horsepower for about 5/1000 second switch-over time.

IV. POSSIBLE APPLICATIONS OF A PRACTICALLY NON-INERTIAL

ELEVATOR WITH LOW-POWER REQUIREMENT

a. Remote Control of Flying Missiles

The use of the practically inertia-free elevator on remotely controlled flying missiles affords a fundamental simplification of the remote control. The normal elevator must, with regard to its inertia, be controlled in relation to the deflection; that is, to each signal (or command) of the remote control there corresponds a definite elevator deflection. A continuous variation of the elevator action therefore requires a device that transforms the oncoming electric command in corresponding elevator settings.

On the practically non-inertial elevator, however, every desired intermediate value of elevator action can be formed from a suitable time sequence of full elevator deflections (fig. 19). The sole premise is that the frequency of the periodic elevator change is chosen large enough so that the flying missile, owing to its low natural frequency, transmits the periodically rapidly varying full elevator deflections satisfactorily. Such a control therefore requires for consistent variation of control action no intermediate device for transforming the order in the desired elevator setting, as the practically inertia-free elevator by utilization of the inertia of the flying missile takes over the transformation itself. In other words, on the practically inertia-free elevator the consistent control in contrast to the elevator afflicted with inertia requires no more effort than a simple "yes" - "no" control. Thus the receiver can be cut in direct at the elevator as in the simple "on - off" control (reference 8).

The previously described spoiler mechanism (fig. 16) was installed on a flying missile of 1500 kilograms total weight and the receiver cut in direct at the elevator. The modulation frequency was 5 Hz; the maximum natural frequency of the missile, about 1 Hz. The measurements indicated satisfactory functioning of the control and extensive flight tests disclosed no objections (reference 11).

b. Artificial Stabilization of Flying Missiles

Remotely controlled flying missiles frequently require artificial stabilization of one body axis, preferably the longitudinal axis, when they go intentionally or unintentionally in a dive, because the pure aerodynamic stabilization of the longitudinal axis - due to gravity - fails in a vertical dive. The simplest form of such an artificial stabilization of the longitudinal axis consists in connecting a "position" gyroscope in the aileron. The elementary form of stabilization is indicated when the always available air damping is sufficient to damp out external disturbances quick enough and the elevator reversal interval is short enough so that the phase displacement between the command of the gyroscope and the response to the command by the elevator results in low and permissible amplitudes of the stationary rolling oscillation accompanying this type of stabilization.

For an abrupt connecting control corresponding to the spoiler the stationary amplitude of the roll oscillation with

stabilization of the longitudinal axis without artificial damping is:

$$\phi = 114.4 \frac{M_Q \Delta t}{M_D}$$

- ϕ amplitude of stationary stabilization oscillation ($^\circ$)
- M_Q aileron moment of elevator coupling abruptly to maximum value (mkg)
- Δt time interval between switch-over command of gyroscope and actual reversal of aileron moment (s)
- M_D aerodynamic constant of damping in roll (mkg) at $(\dot{\phi} = 1)$

The necessary aileron moment and the attainable aerodynamic damping in roll are usually fixed within narrow limits for each project. But the switching-over period can be considerably lowered with the introduction of the spoiler in place of the normal control. This explains why the simplest form of stabilization of the longitudinal axis by position gyroscope and aileron with the spoiler is applicable even in cases where with the use of a normal control this would not be permissible.

In the numerical comparison of this possibility for specific projects it is to be borne in mind that the normal elevator aerodynamically couples almost free from inertia, while the spoiler has an aerodynamic lag (reference 3). The ideal value for the airtight spoiler is

$$\Delta t = \Delta t_{\text{mech}} + \Delta t_{\text{aerody}} = \Delta t_{\text{mech}} + 10 \frac{a}{v}$$

- Δt_{mech} mechanical lag (s)
- Δt_{aerody} aerodynamic lag (s)
- a distance spoiler-profile trailing edge (m)
- v flying speed (m/s)

This aerodynamic inertia of the spoiler does in no way, however, balance its lowered mechanical inertia, but simply

reduces the gain secured on the mechanical side a little. In case of necessity the aerodynamic inertia can be considerably lowered without other drawbacks by the interrupter permeable to air (references 3, 9, and 12).

c. Artificial Stabilization of Control Direction

On flying missiles with axially symmetrical effective wing system, such as cross or annular wings, the stabilization of the longitudinal axis can be avoided in certain conditions in favor of stabilization of the control direction. For instance, on a bomb such as in figure 20, it is completely immaterial whether the missile turns about its longitudinal axis in flight or maintains a certain position. The sole essential is that the required control direction be maintained independent of the rotation, that is, at any instant assured by actuation of the correct elevator. Such a control requires no aileron, but merely a position gyroscope fitted with an elevator selector (fig. 21), hooked up correctly in the control of the flying missile. To obtain with the two control directions prescribed by the tail unit an exact position of the resulting control directions without additional equipment, the missile must turn fast enough through corresponding twist of the wing incidence and thus give a satisfactory average value formation adapted to the duration of the command. The position gyroscope is so connected between receiver and interrupter elements that, for instance, at the simplest version (fig. 21) the elevator remains switched on as long as it remains in the quadrant of $\pm 45^\circ$ while the missile turns. If the missile turns further, the gyro stabilized collector actuates the elevator entering in these quadrants. In the design of the collector of figure 21, the adaptation of the control direction to the expected direction is still stepped very abruptly and corresponds in no way to the theoretically required sine law. In the arrangement of figures 22 and 23 the adaptation to the theoretically required sinusoidal force distribution is further advanced and sufficient, as a rule, for practical demands in combination with the stationary rotation about the longitudinal axis.

The use of a normal elevator with this control introduces difficulties due to the relatively great inertia of the elevator, while the spoiler control with its lower inertia usually offers no obstacle to the application of the artificial stabilization of the control direction. One can even go further and superimpose the simplest remote control with the artificial stabilization of the control direction, which then gives the simplest imaginable

stabilized remote control for axially symmetrical effective wing systems. This control requires only the receiver and a position gyroscope; aileron, damping gyroscope, command transmitter for the elevators and, in case of necessity, the servomotor of the elevators are eliminated through utilization of the low inertia and the small power requirements of the spoilers. Since a position gyroscope in its functioning is substantially less susceptible to revolutions per minute decrease than a damping gyroscope, the previously started gyroscope can, for short flights, be made to run free. The elimination of the damping gyroscope in this case also obviates the gyroscope battery and the gyroscope transformer (reference 10). The unusually low power required of the control and the absence of all auxiliary equipment make it possible to use batteries of large storage capacity, which fulfills an urgent wish of practice. This rotatory control has the added property of removing trimming errors due to design defects in consequence of rotation of the whole missile.

All of these factors described were realized in a subsequent development of the 1500 kilogram missile (fig. 20). Its maximum rate of revolution was chosen at 1 revolution per second. The simple design is represented in the wiring diagram (fig. 21).

V. AERODYNAMIC RESISTANCE OF THE SPOILER CONTROL

For reasons of principle the opinion may be held that the spoiler control could achieve importance only when the aerodynamic resistance of the control is of no significance or even desired (that is, for inferior gliders or diving missiles). For appraisal of this problem, the lift/drag ratio ($\Delta c_a / \Delta c_w$) of the control element of figures 5 and 7 is shown plotted against the Mach number in figure 24; Δc_w is the additional drag at full spoiler deflection over the drag without spoiler, that is, the sum of induced drag and additional drag produced by separation of flow; Δc_a is the lift produced by the spoiler. It is seen that a suitable spoiler arrangement attains a lift/drag ratio of over 4:1 even for the unfavorable aspect ratio of the explored control element. The spoiler can, of course, be so controlled also by increasing the spoiler paths that it disappears in the profile when in neutral position, hence produces no additional drag. Moreover, it is known from earlier experiments that the aerodynamic resistance (and the aerodynamic switch-over period) of the normal spoiler can be improved without loss of efficiency by proper perforations in the spoiler plates (references 12 and 9). Furthermore,

for a missile with good L/D a more favorable aspect ratio of the control element will be chosen than in the present case and the cited thickening up of the profile trailing edge replaced by a corresponding lengthening of the profile. Other possibilities of lowering the additional drag of the control include increased fuselage length, hence, reduced tail-plane requirement, and substitution of one of the conventional two-axes control for three-axes control.

11
Translated by J. Vanier
National Advisory Committee
for Aeronautics

REFERENCES

1. Weick, F. E., Soulé, H. A., and Gough, M. N.: A Flight Investigation of the Lateral Control Characteristics of Short Wide Ailerons and Various Spoilers with Different Amounts of Wing Dihedral. NACA Rep. No. 494, 1934.
2. Weick, F. E., and Wenzinger, C. J.: Preliminary Investigation of Rolling Moments Obtained with Spoilers on Both Slotted and Plain Wings. NACA TN No. 415, 1934.
3. Kramer, M., Zobel, Th., and Esche, G. G.: DVL-Unterbrechersteuerung. FB Nr. 964.
4. Secret patent 845/40 - 10/19/39.
5. Patent application D 87 371/XI 62b - 3/28/42.
6. Patent application D 89 149/XI 62b - 11/10/42.
7. Bock, H., and Fischer, W.: Vorschlag zur Erhöhung der Betriebssicherheit des Unterbrecher-Magnetsystems des Geräts "Fritz X." DVL-ZLB - 10/30/42.
8. Secret patent 149/41 - 5/8/40.
9. Secret patent 138/41 - 6/24/40.
10. Patent application D 89 130/XI 62c - 11/7/42.
11. Bock, H., Ernst, G., and Kramer, M.: Ergebnis der "Fritz X" - Erprobung der DVL bei der Erprobungsstelle Süd in Foggia (3/15 to 4/10/42). DVL - ZLB - 7/1/42. This report contains a bibliography of papers on the device "Fritz X."
12. Kramer, M., and Zobel, Th.: Modellversuche zur Verbesserung der Unterbrecherquersteuerung. FB 583.

THE HISTORY OF THE

REPUBLIC OF THE UNITED STATES

OF AMERICA

FROM THE FIRST SETTLEMENTS TO THE PRESENT TIME

BY

W. H. RICHMOND

NEW YORK

1850

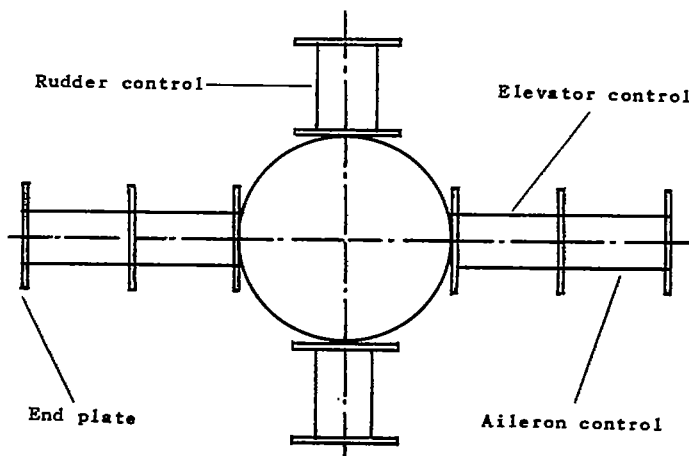

Figure 1.- Tail-plane design of remotely controlled missile of high flying speed.

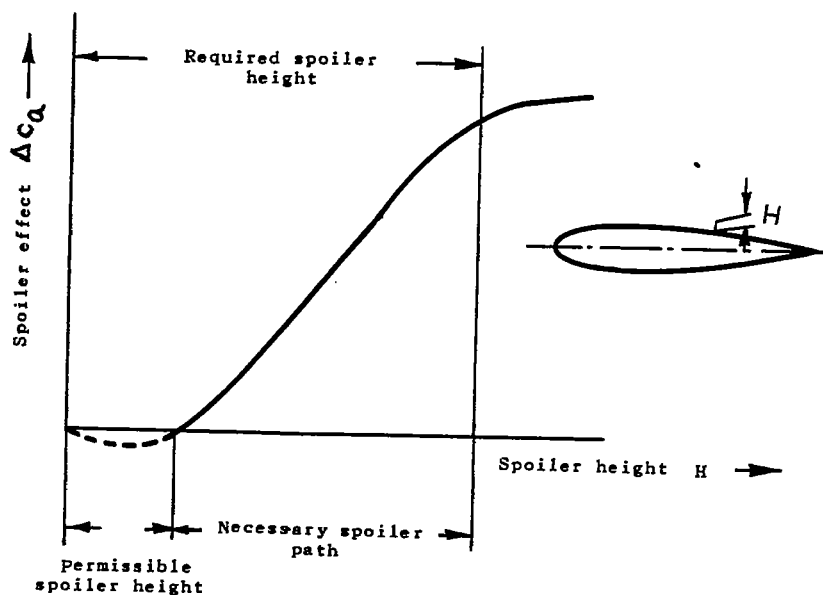

Figure 2.- Fundamental variation of the spoiler effect with the height of the spoiler.

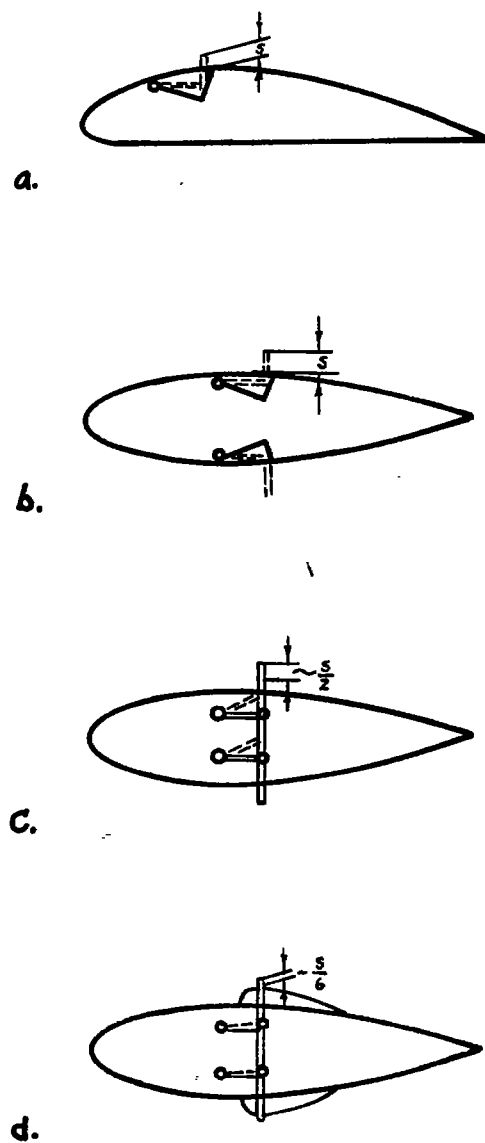

Figure 3.- Development of spoiler control for reducing the spoiler path s .

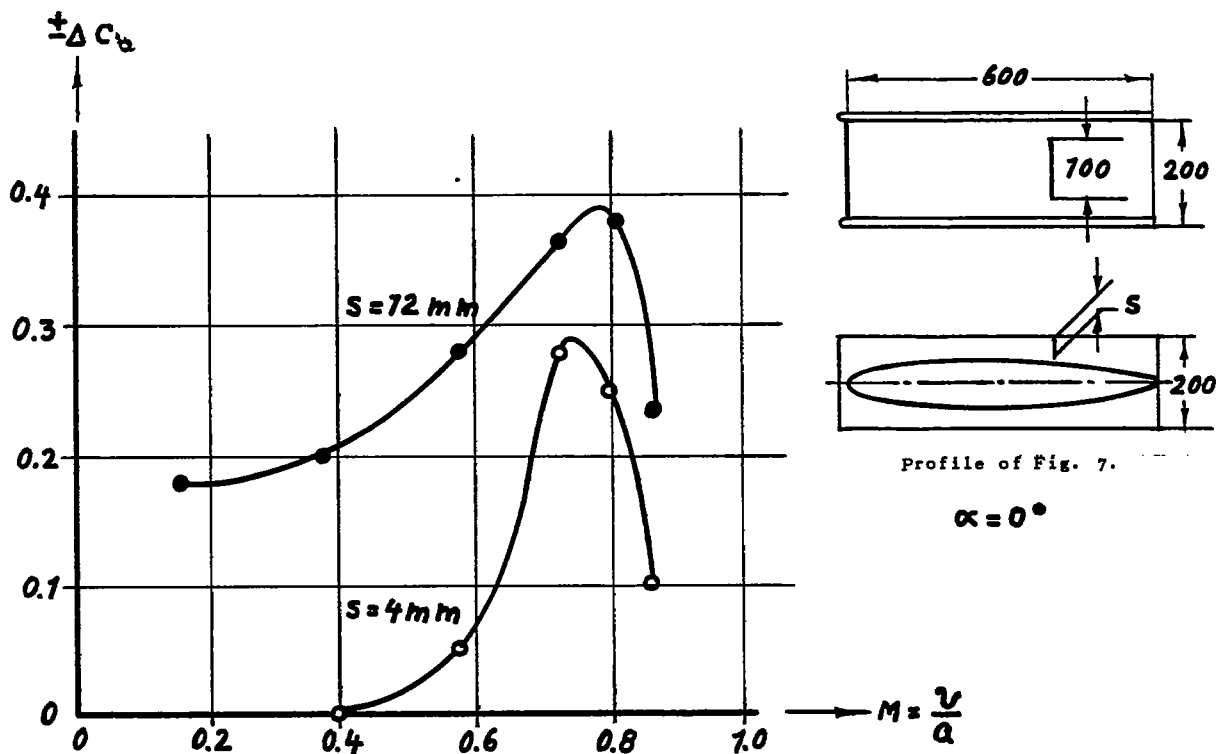

Figure 4.- Variation of spoiler action with the Mach number for different spoiler heights without profile step.

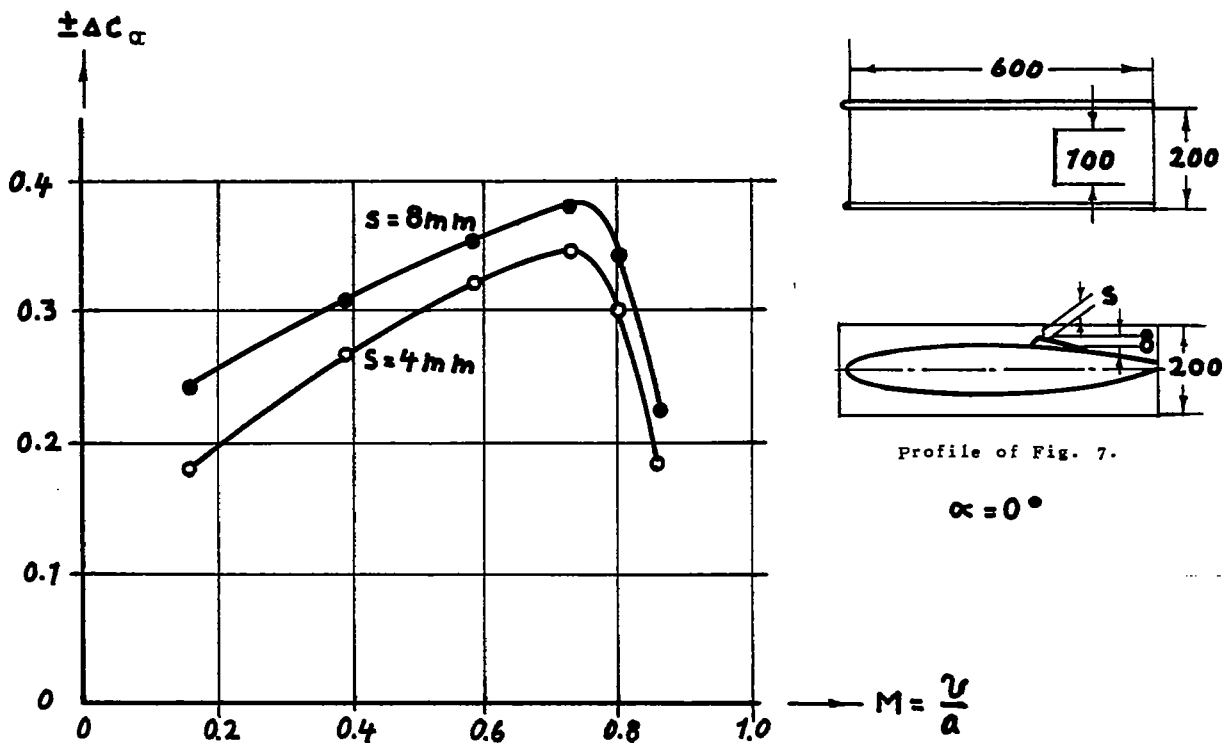

Figure 5.- Variation of spoiler action with the Mach number for different spoiler heights - with profile step.

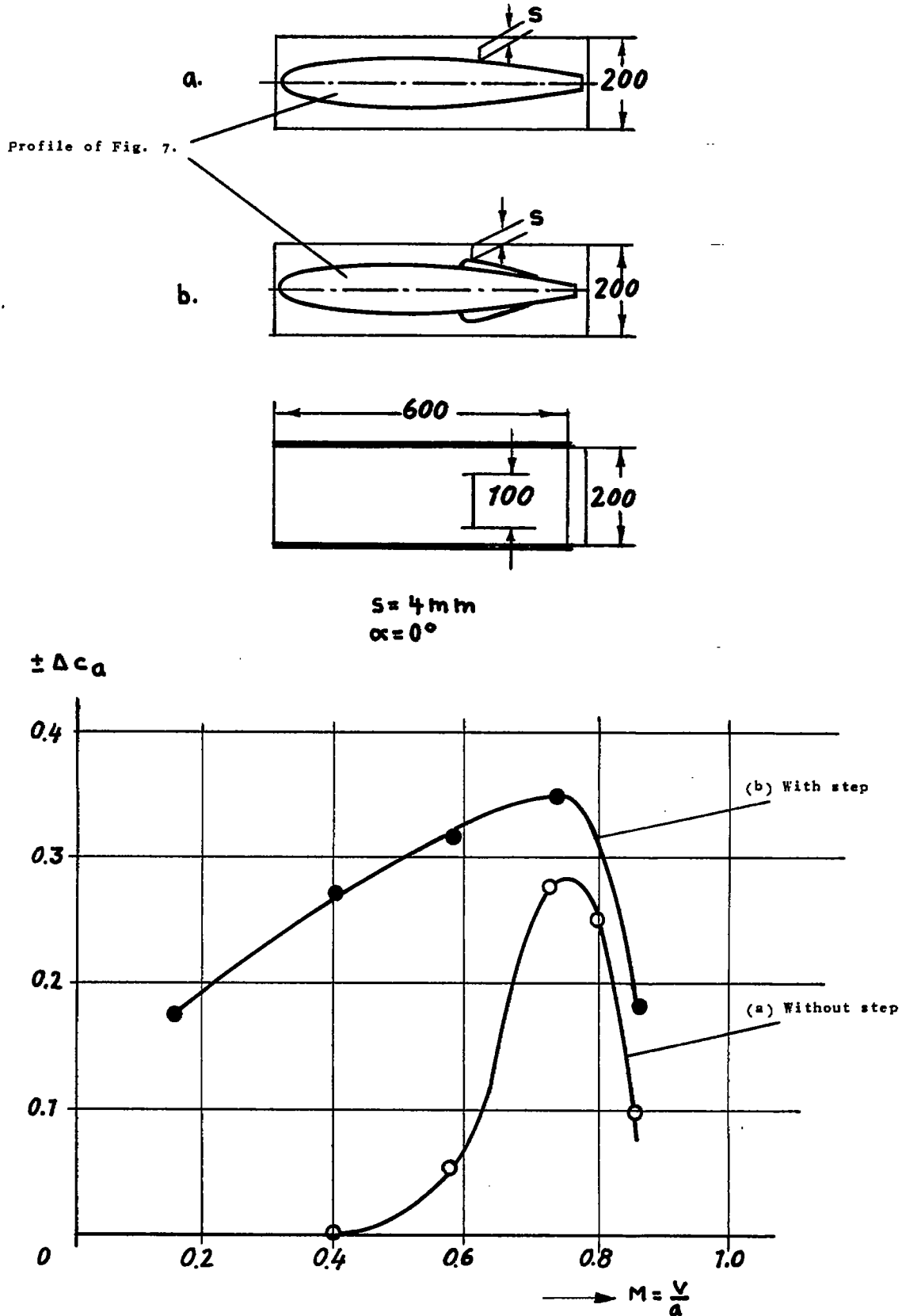

Figure 6.- Comparison of spoiler action on profile with and without step plotted against Mach number.

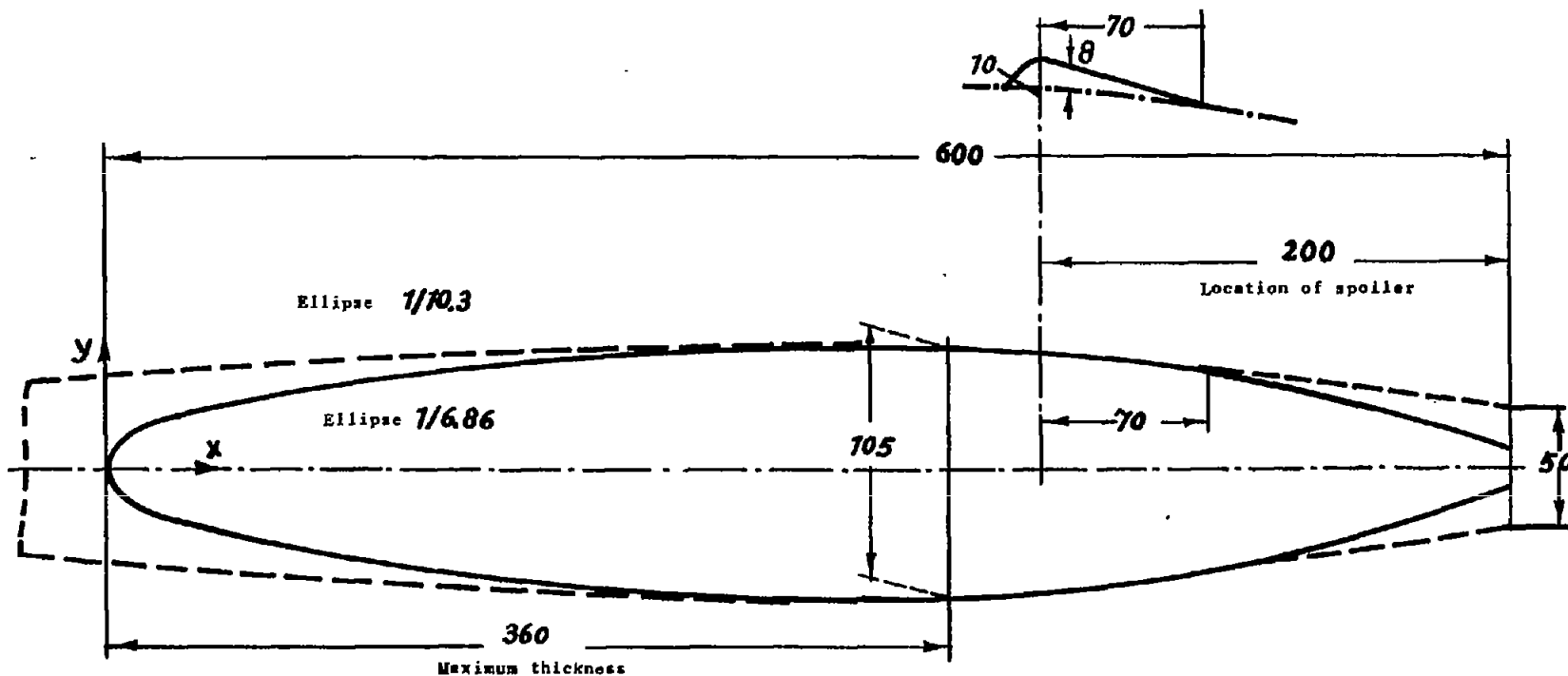

Table of basic profile

X	0	11.25	22.5	45	67.5	90	135	180	225	270	360	400	440	480	520	600
Y	0	14.2	19.7	25.6	30.4	34.3	40.5	45	48.3	50.5	52.5	51.5	47.5	40.1	29.3	7.5

Figure 7.- Investigated profile.
 Thickness 16.6 percent
 Maximum thickness 60 percent back
 Trailing edge thickened

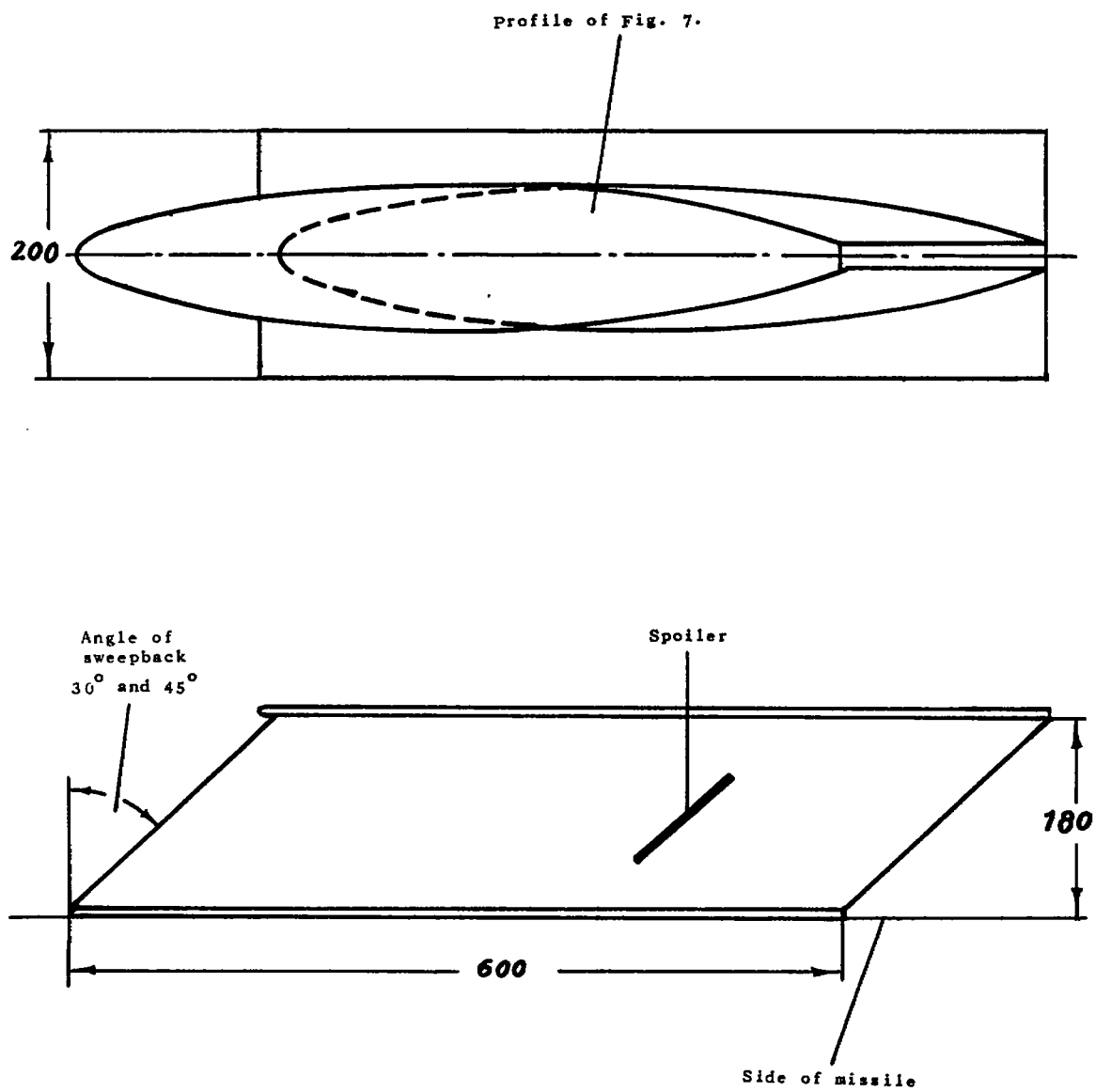

Figure 8.- Experimental design of a sweptback control element.

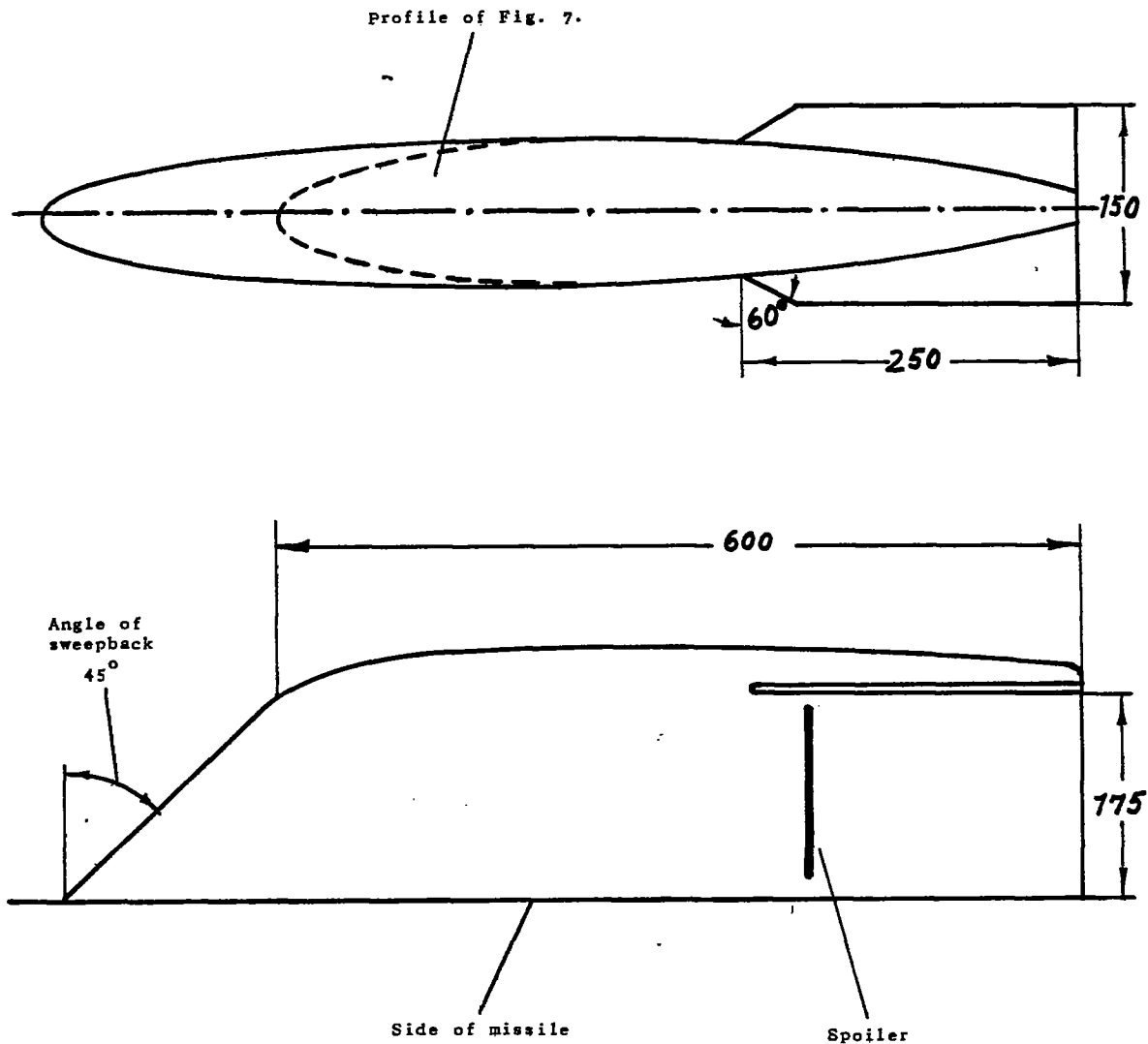

Figure 9.- Control element - leading edge 45° sweepback, trailing edge straight.

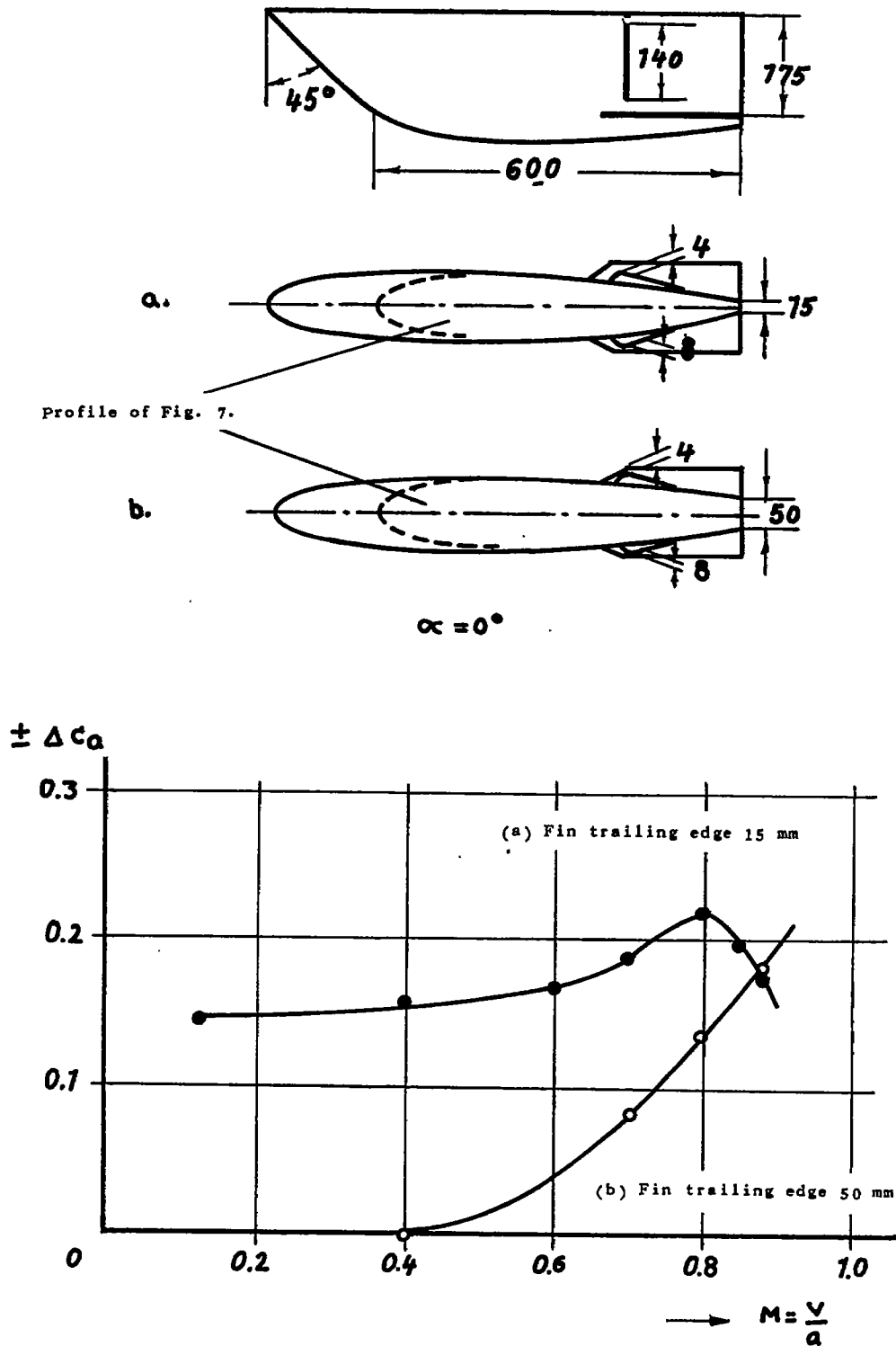
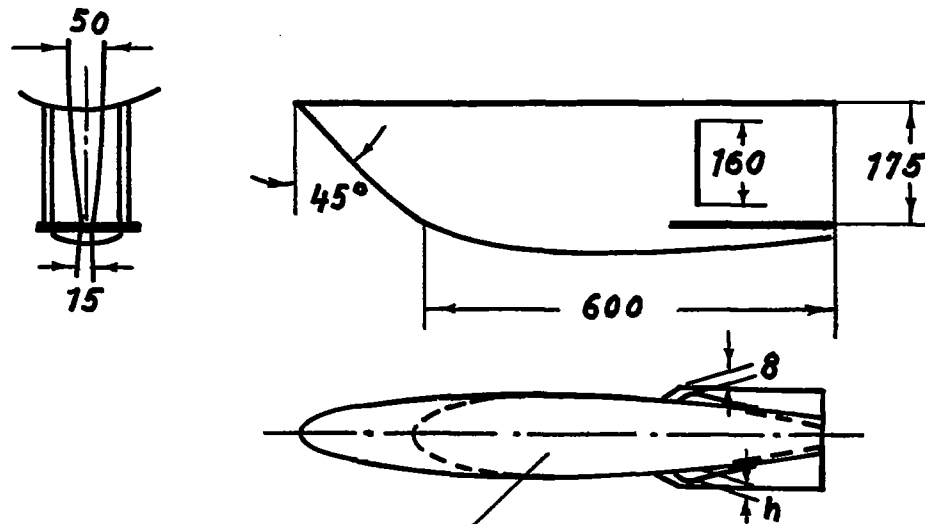

Figure 10.- Variation of elevator action with the Mach number for fin trailing edge of varying thickness.



Profile of Fig. 7.

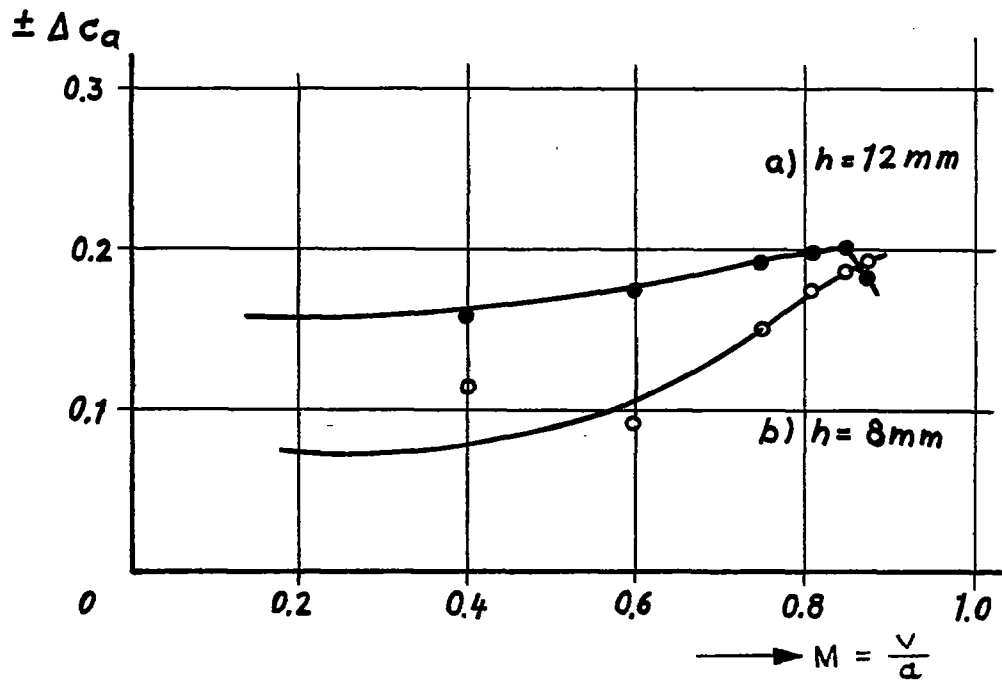

Figure 11.- Variation of elevator action with the Mach number for several heights of step of the profile.

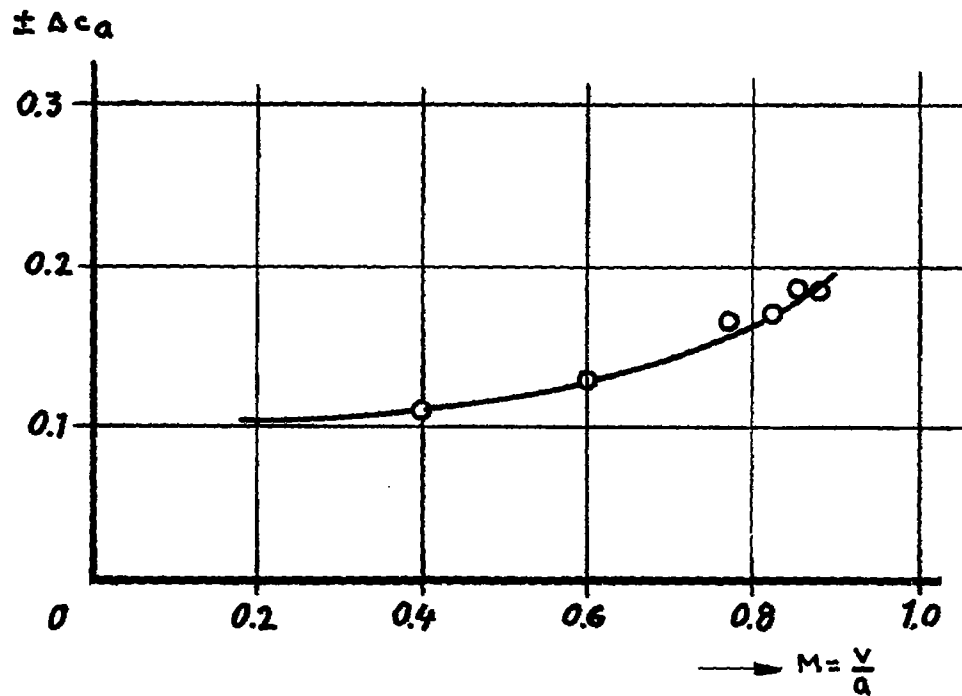
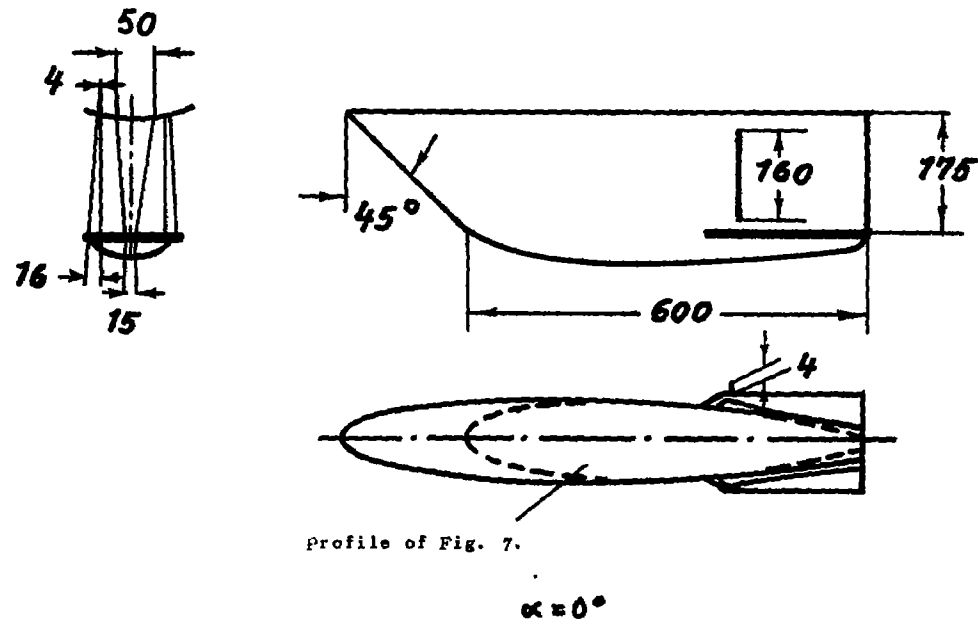
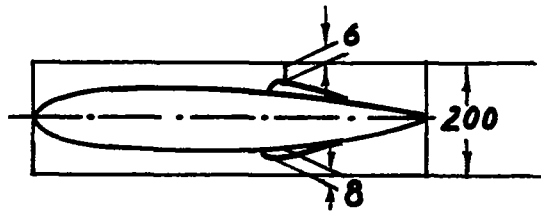
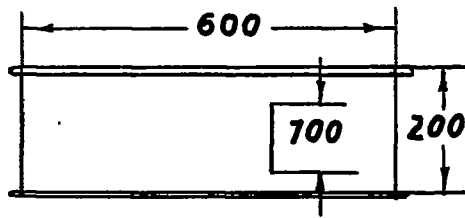

Figure 12.- Variation of elevator action with the Mach number for continuously varied trailing-edge thickness and step height.



Profile of Fig. 7.

$\alpha = 0^\circ$

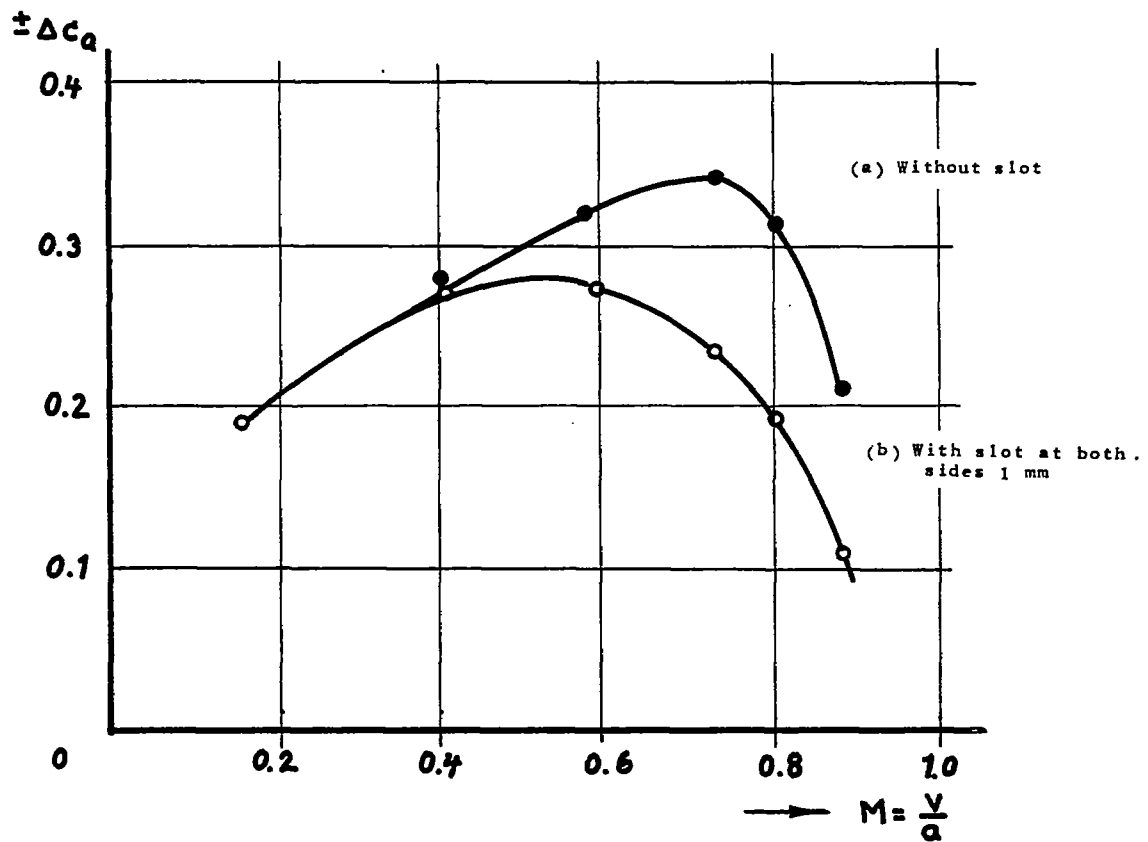

Figure 13.- Variation of elevator action with the Mach number for an arrangement with and without elevator slot.

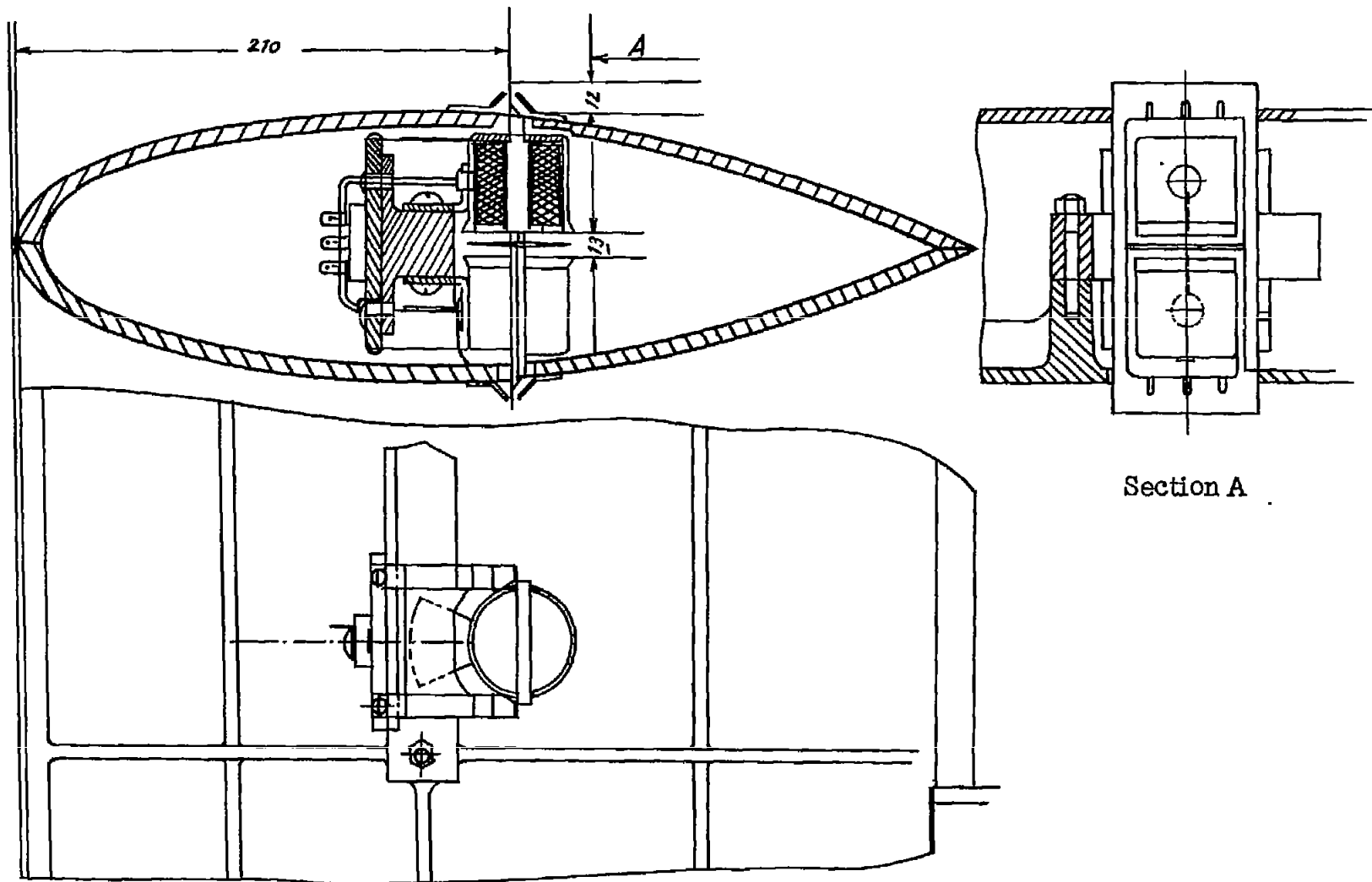
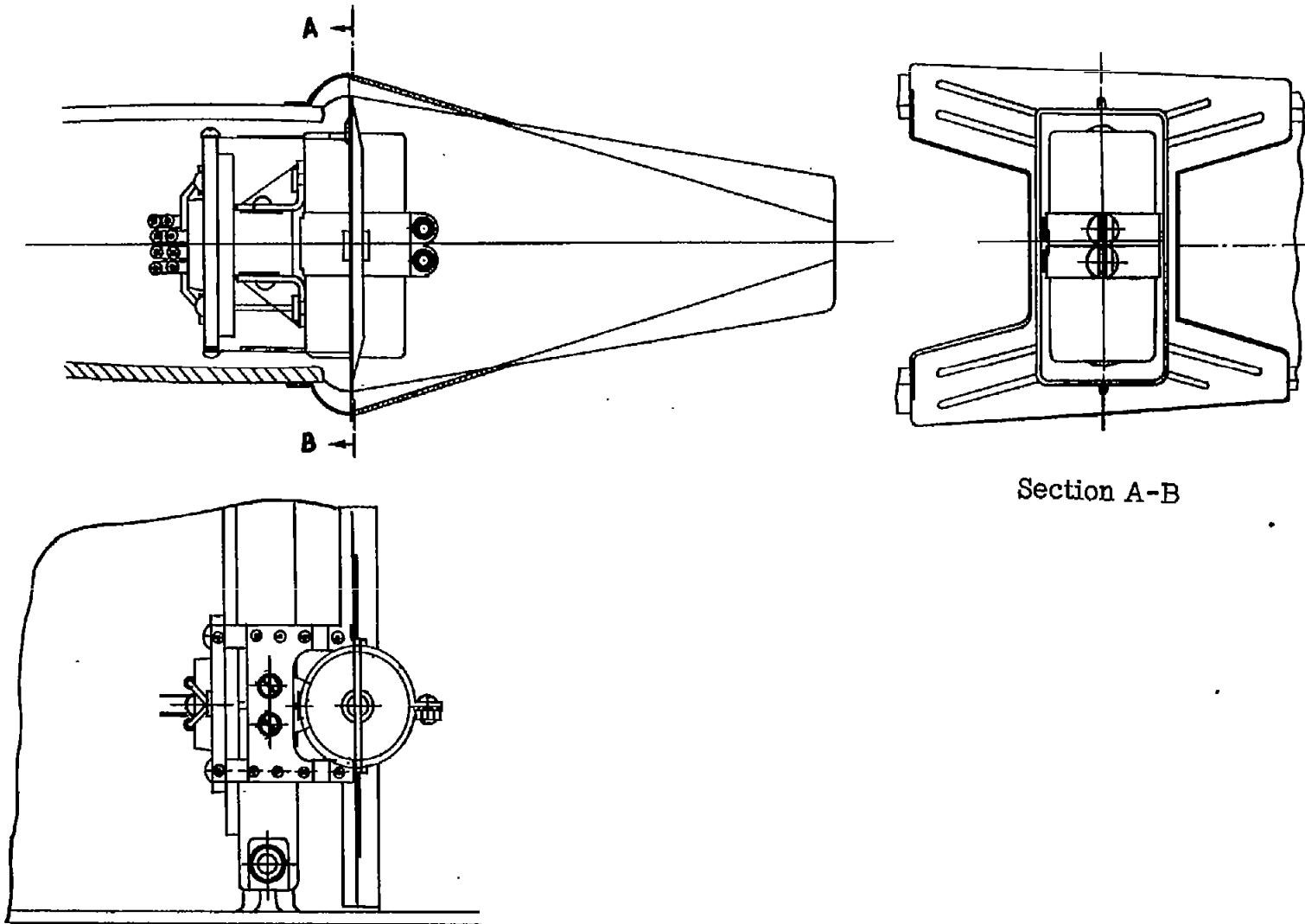
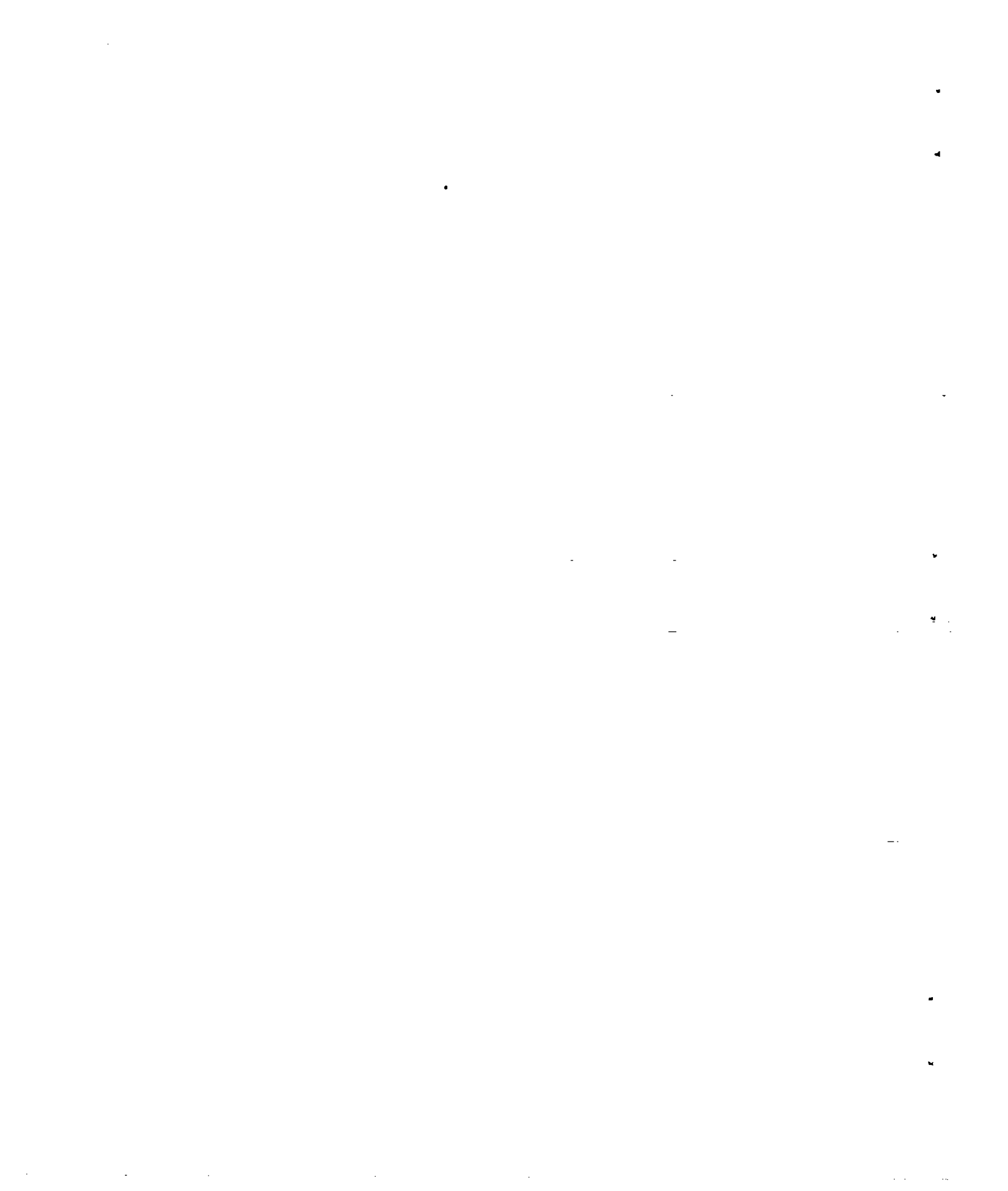

Figure 14.- One of the original drawings of the spoiler transmitted October 15, 1939 for quantity production to the industry.



Section A-B

Figure 15



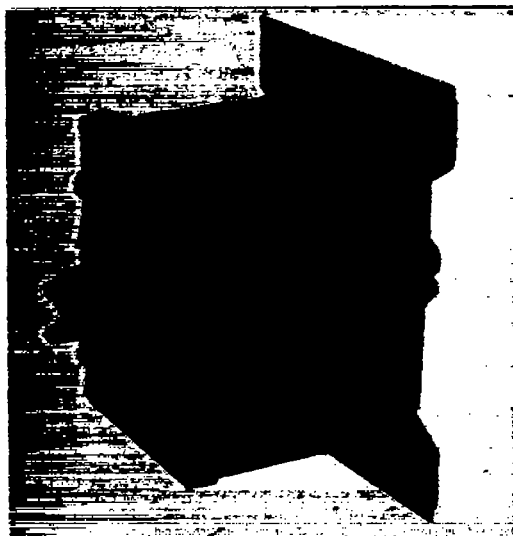

Figure 16.- Spoiler setting mechanism for figure 15.
[The German figure from which this figure was made
was indistinguishable.]



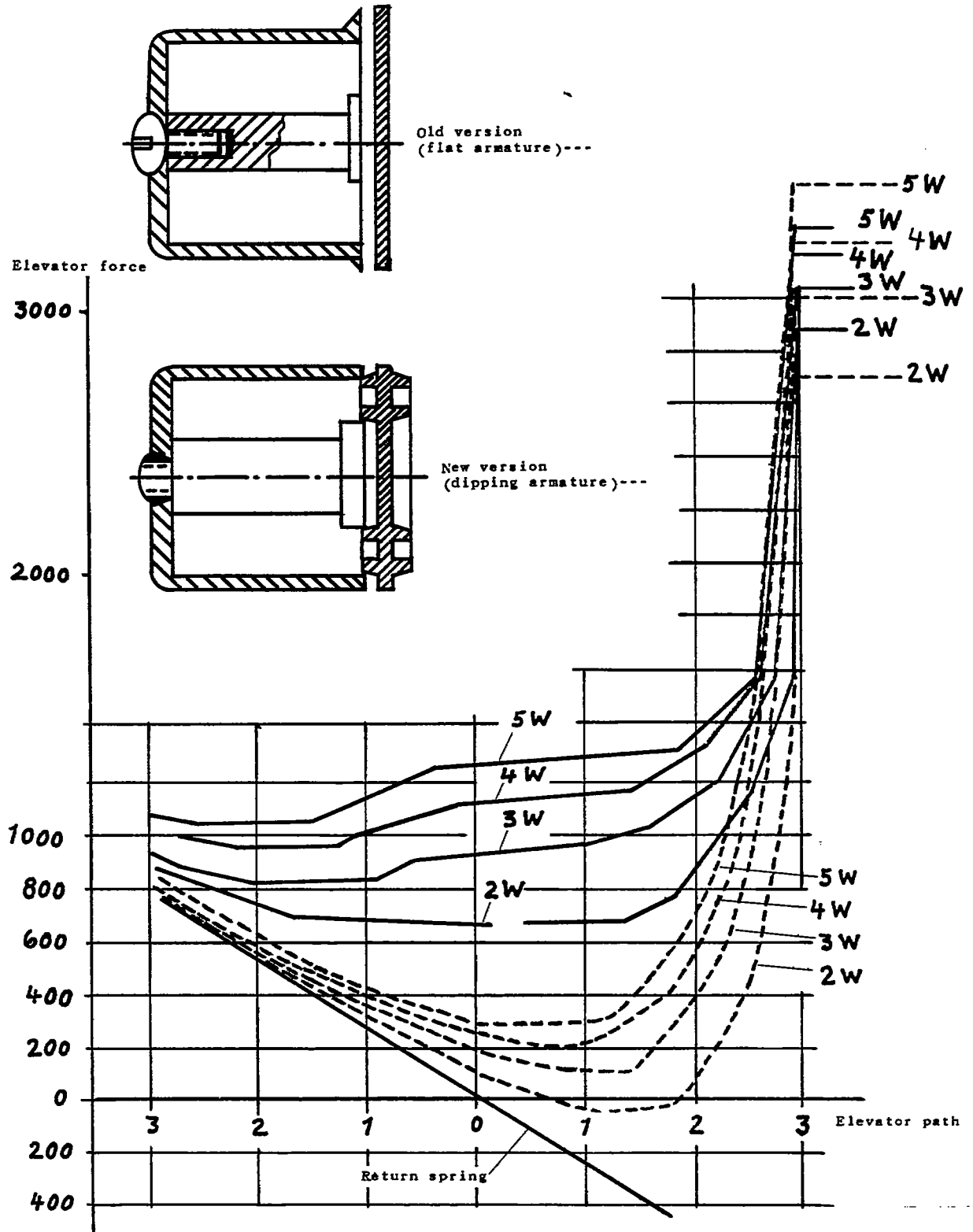
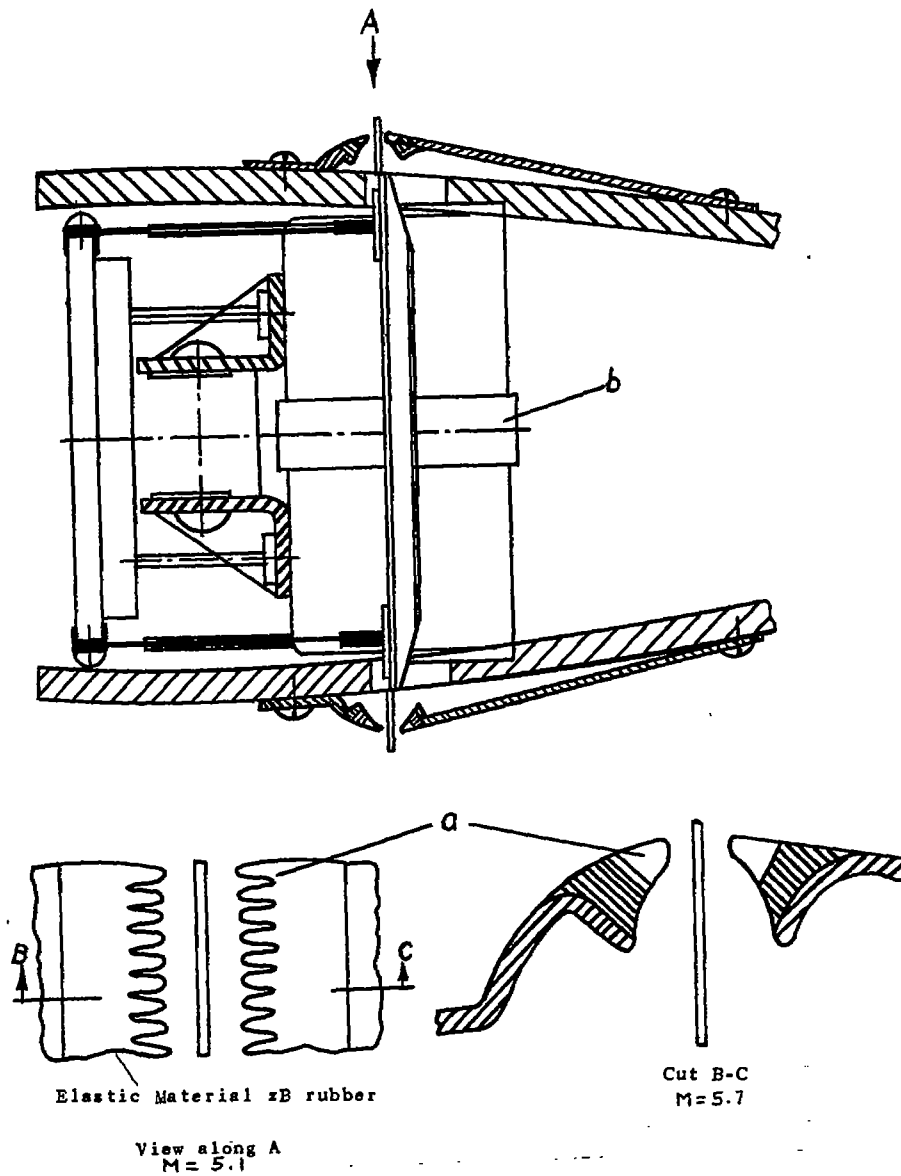

Figure 17.- System of magnets improved by change from flat to dipping armature.



- (a) Elastic edges of the spoiler.
 (b) Guard ring for the protective packing of the magnet slots.

Figure 18.- Protection of sensitive parts of spoiler against dirt.

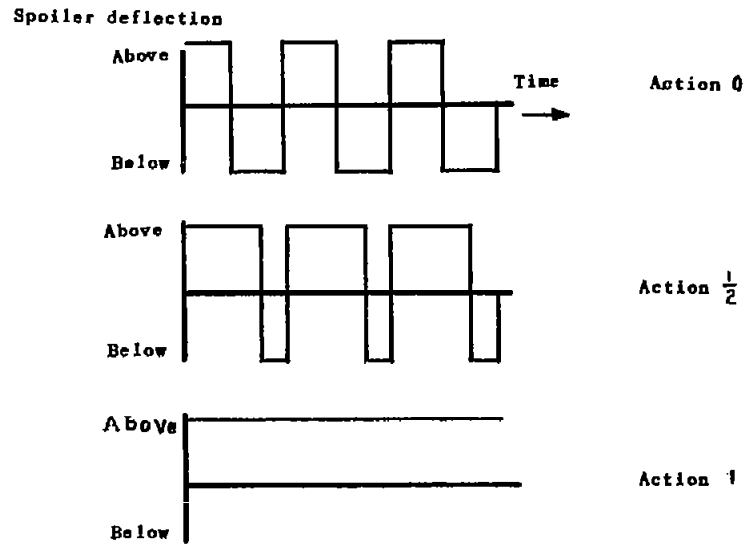

Figure 19.- Continuous command transmission by periodical reversal of full spoiler deflections.



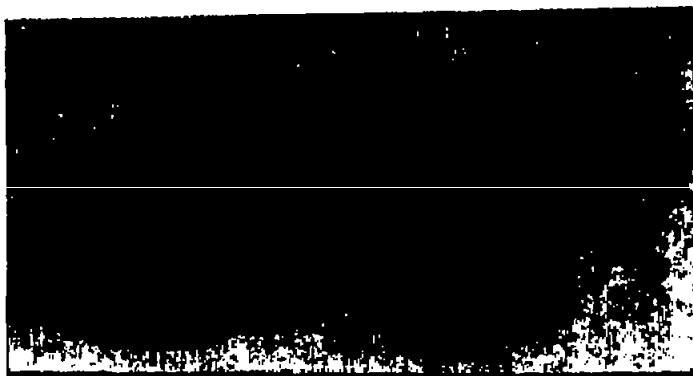

Figure 20.- Aerodynamic-axially symmetrical missile of 1500 Kg total weight with remotely controllable spoiler-rotation control for application at high Mach number range. [The German figure from which this figure was made was indistinguishable.]



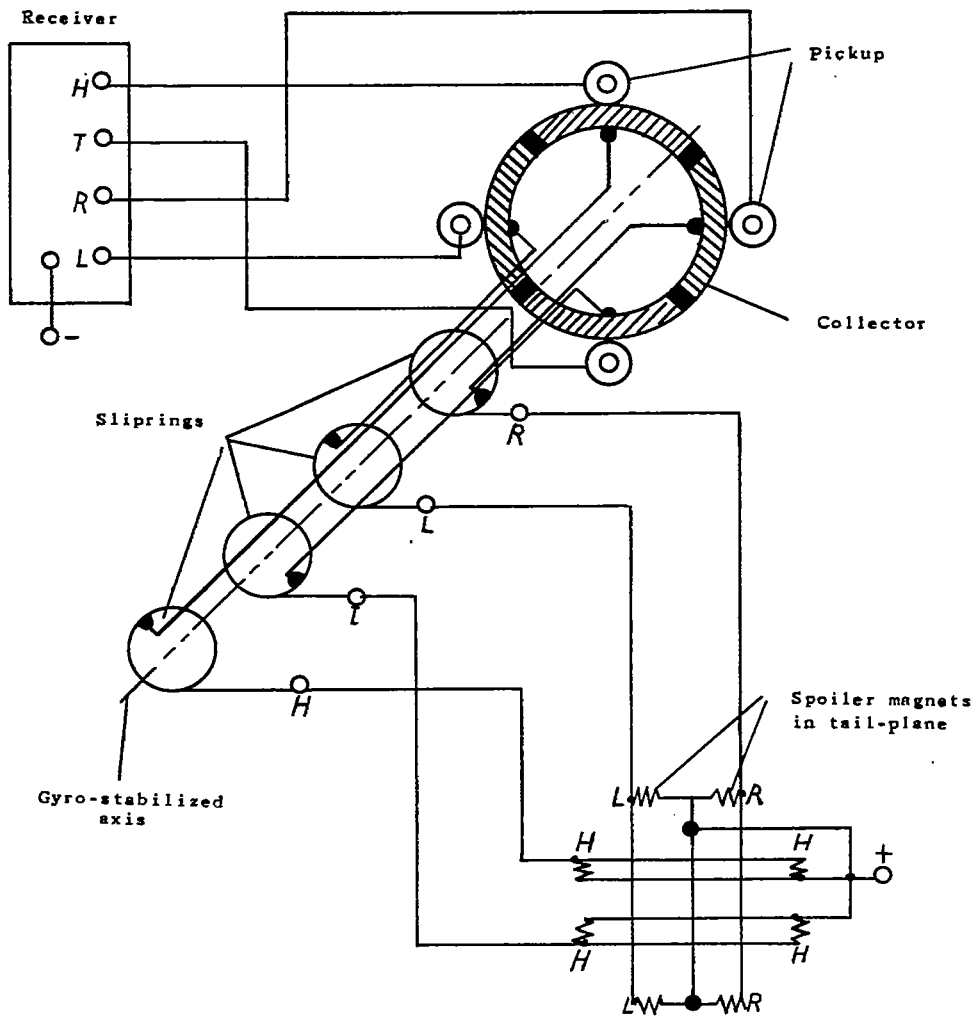
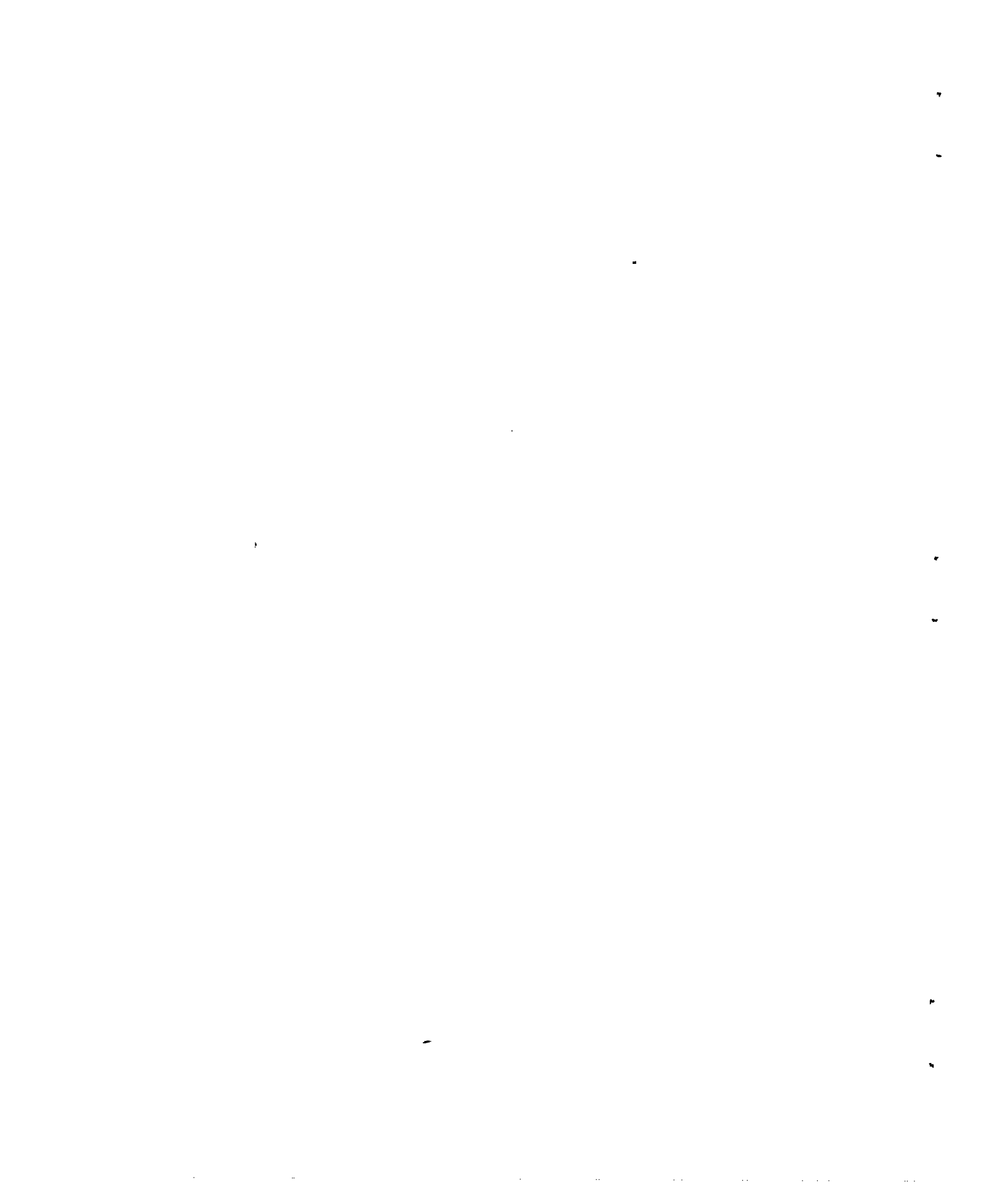

Figure 21.- Wiring diagram of spoiler-rotation control.



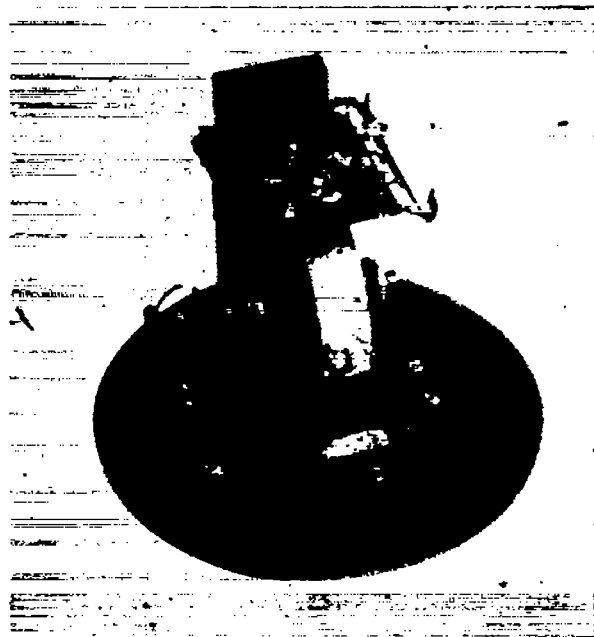
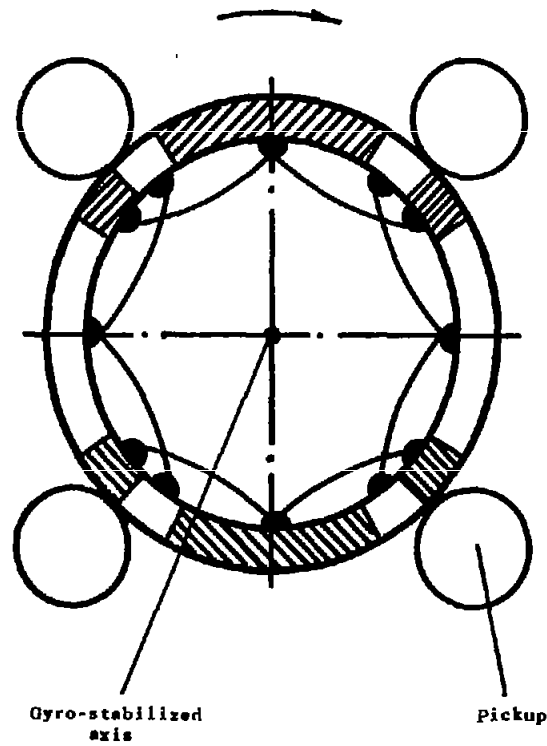

Figure 22.- Position gyroscope for spoiler rotation control (experimental version). [German figure from which this figure was made was indistinguishable.]





This arrangement satisfies the expected direction exact every 45° , while by Fig. 21 the direction is maintained only every 90° .

Figure 23.- Design of collector of figure 21 for better agreement of the control direction to the expected direction.

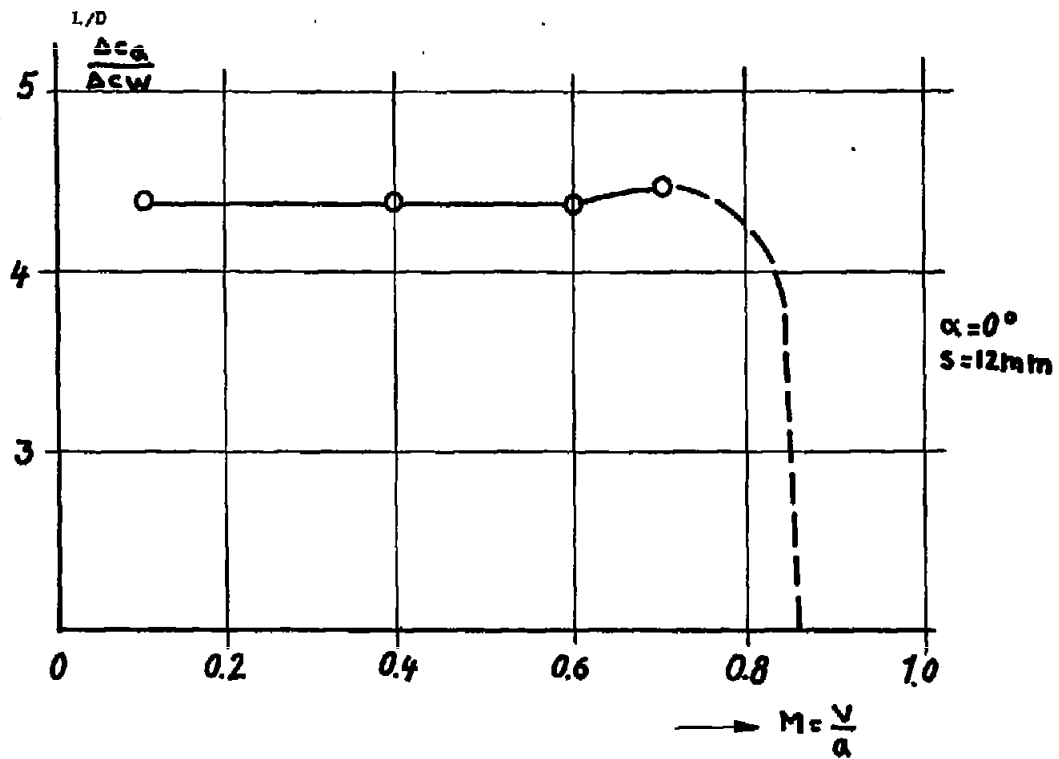

Figure 24.- Variation of L/D for a spoiler element of figure 4 plotted against the Mach number.

TITLE: Development of Spoiler Controls for Remote Control of Flying Missiles

ATI- 3167

DATE:

5 June 1949

AUTHOR(S) : Ernst, G.; Kramer, M.

ORIG. AGENCY: Deutsche Versuchsanstalt fuer Luftfahrt

ORIG. AGENCY NO.

(None)

PUBLISHED BY : Zentrale fuer wissenschaftliches Berichtswesen Berlin-Adlershof

PUBLISHING AGENCY NO.

FB-1717

DATE	DOC. CLASS.	COUNTRY	LANGUAGE	PAGES	ILLUSTRATIONS
Jan '43	Unclass.	Germany	German	39	photos, diagrs, graphs

FOREIGN TITLE: Entwicklung der Unterbrechersteuerung fuer ferngesteuerte Flugkoerper

TRANSLATION BY: National Advisory Committee for Aeronautics, Washington, D.C.

NO. TM-1210

ABSTRACT:

A discussion is presented on the aerodynamic, structural, and instrumental development of a spoiler control for guided missiles. The spoiler was made to operate satisfactorily up to a Mach number 0.9 by increasing the airfoil trailing-edge thickness, thereby reducing the boundary layer; and by projecting the spoiler from a faired "step" which eliminated the dead spot at low deflections. There is no indication that the spoiler will be effective at supersonic speeds. Details of the construction and instrumentation are outlined.

DISTRIBUTION: SPECIAL. All requests for copies must be addressed to Trans. Agency (5)-

DIVISION: Guided Missiles (1)
SECTION: Aerodynamics and Ballistics (4)

SUBJECT HEADINGS: Spoilers (88700); Control systems (26100); Missiles - Guidance and control (62030)

x5180 111650

AD-B810 240

TECHNICAL INDEX

Previously Cataloged as Captured Document No. ZWB/FB/RE/1717