

UNCLASSIFIED

AD NUMBER

ADB814089

CLASSIFICATION CHANGES

TO: unclassified

FROM: restricted

LIMITATION CHANGES

TO:  
Approved for public release; distribution is unlimited.

FROM:  
Distribution authorized to DoD only; Administrative/Operational Use; JAN 1943. Other requests shall be referred to National Aeronautics and Space Administration, Washington, DC. Pre-dates formal DoD distribution statements. Treat as DoD only.

AUTHORITY

NACA list dtd 28 sep 1945; NASA TR Server website

THIS PAGE IS UNCLASSIFIED

FILE COPY  
NO 8

TECHNICAL NOTES

NATIONAL ADVISORY COMMITTEE FOR AERONAUTICS

NO. 382

TESTS OF FLAT PANELS WITH FOUR TYPES OF STIFFENERS

By Alfred S. Niles  
Stanford University

**NASA FILE COPY**

Loan expires on last  
date stamped on back cover.  
**PLEASE RETURN TO  
REPORT DISTRIBUTION SECTION  
LANGLEY RESEARCH CENTER  
NATIONAL AERONAUTICS AND  
SPACE ADMINISTRATION  
Langley AFB, Virginia**

THIS DOCUMENT ON LOAN FROM THE FILES OF

NATIONAL ADVISORY COMMITTEE FOR AERONAUTICS  
LANGLEY RESEARCH CENTER  
LANGLEY FIELD STATION, VIRGINIA

IT IS TO BE USED FOR

RESEARCH PURPOSES ONLY AND IS NOT TO BE REPRODUCED  
OR TRANSMITTED IN ANY FORM OR BY ANY MEANS

NATIONAL ADVISORY COMMITTEE FOR AERONAUTICS  
1215 AVENUE B  
WASHINGTON 25, D.C.

Washington  
January 1943

NATIONAL ADVISORY COMMITTEE FOR AERONAUTICS

-----  
TECHNICAL NOTE NO. 882  
-----

TESTS OF FLAT PANELS WITH FOUR TYPES OF STIFFENERS

By Alfred S. Niles

SUMMARY

Fifty-one aluminum-alloy panels were tested as flat-end columns. The test specimens included all possible combinations of two lengths, four stiffener spacings, and four stiffener designs, and were mostly in duplicate pairs. The test data include the maximum loads carried, action of the panels after the maximum loads carried, action of the panels after the maximum load had been passed, amount of twisting of the stiffeners, photographs showing the character of failure of many of the panels, and other pertinent items.

Supplementary tests were made on 11 of the panels in simple bending and on 6 individual stiffeners in compression.

INTRODUCTION

In 1938, Carah and Park (reference 1) made a number of tests to determine the ultimate loads of channels acting as cantilever beams subjected to concentrated forces at the free ends. The ultimate loads obtained when the line of action of the force passed through the centroid of the section were found to be from 20 to 43 percent lower than those obtained when the force was applied through the shear center. This considerable reduction in the ultimate load suggested the possibility that the load-carrying capacity of sheet-stiffener combinations would be a maximum if the stiffeners were so designed that the line of action of the forces due to interaction of sheet and stiffener would pass through the shear center of the stiffener and be parallel to one of the principal axes of its cross section.

To explore the validity of this hypothesis and to obtain additional data regarding the general problem of stiffener design, the four stiffener sections shown in figure 1 were selected. For easier comparisons all four

sections were of the same sectional area and three, C, Z, and S, had equal moments of inertia about the centroidal axis parallel to the flanges. The fourth section, U, was identical with the C section except that, when employed in combination with sheet, it was attached at the center of the web rather than at the flange. Study of figure 1 will show the following relations to exist when the four sections are used as stiffeners in connection with flat sheet. In all four cases the load imposed on the stiffener by the tendency of the sheet to buckle is assumed to act normal to the plane of the sheet and along the line of rivets. In the case of the C section, this force will be parallel to a principal axis of the section but will pass to one side of the shear center, that point being "behind" the web. The shear center of the Z section will coincide with the centroid because of point symmetry, but the force will not be parallel to a principal axis. When the U section is used, the force will act along an axis of symmetry of the section and will thus act along a principal axis and pass through the shear center.

The S section was developed by Brown and Van Every, who originated the project covered by this report. Although this section was devised independently by Brown and Van Every, its prior existence is shown by sketches in reference 2. This section was devised to meet the requirements that the load should pass through the shear center in a direction parallel to a principal axis and that the moment of inertia  $I$  about a centroidal axis parallel to the sheet should be the same as for the C and Z sections. It was impossible to satisfy these conditions with a section similar to the U section without increasing the sectional area.

Actually the S section was first proportioned to the approximate area and moment of inertia desired. An angle between the web and the flanges and a distance between flanges were selected arbitrarily. The angular position of the principal axes was then varied by changing the flange width and the results were plotted to determine the proper value that would make the principal axes parallel and normal to the flanges. Since the section has point symmetry, its shear center is at the centroid. Thus, if the sheet is riveted at the location indicated in figure 1, the load imposed on the stiffener by the sheet passes through the shear center and is parallel to a principal axis of the section.

After the S section had been designed, the C and Z sections were developed so that they had the same area and moment of inertia about centroidal axes parallel to the flanges. Because the thickness and the developed width were fixed by the design of the S section, the only independent design variable remaining was the distance between flanges. The variation of  $I$  with this quantity was plotted in a figure from which the necessary depth of section was determined.

Originally the four stiffener sections were designated by the letters A, B, C, and D, and those letters are used throughout this report to identify individual test specimens. When attached to the panels, the assembly is identified as PA, PB, PC, and PD. During the test program it was found helpful to refer to the original "A" and "D" as "C" and "U" sections since they suggest those letters (see fig. 1) when the sheet to which they are attached is in a horizontal position. When not attached to a sheet, they are both referred to at times as the "channel" section, because of their similarity to the structural channel. Similarly the original B section came to be known as the Z section on account of its similarity to the structural Z section. The original C section was then named the S section since, when reversed, it suggests the letter S, and it was undesirable to attempt to distinguish between two different Z sections. The original designations are shown in parentheses in figure 1.

Although all four sections had the same area and three of them had the same moment of inertia about an axis parallel to the flanges, it was realized that their behavior under load might be quite different. To ascertain these differences and to aid in the interpretation of the action of the sheet-stringer combinations, individual stiffener specimens were tested as cantilever beams, as beams in pure bending, as beams in simple bending, and as flat-end columns. The tests of the specimens as beams indicated nothing of significance for interpreting the action of the panels except what could easily be deduced from accepted beam theory. Detailed accounts of these tests, therefore, are not included in this report.

In order to bring out more clearly any differences in the stiffening effects of the four sections used, the panels were made of relatively heavy stiffeners and light sheet. The panels were made in two lengths and with four stiffener spacings that allowed information to be obtained on some of the other problems of panel design.

Although all the test material was obtained at one time, the tests extended over two school years and were made in three groups, and there were minor differences in technique among the groups. In the first year, the tests on individual stiffeners and compression tests on 20 panels were made by Brown and Van Every. In the second year, compression tests on 15 panels and bending tests on 11 panels were made by H. A. Miner. At the end of the second year, compression tests were made on 16 panels by the writer. With the exception of the data obtained in the third group of tests, the data in this report are taken from the theses and test logs of the students mentioned.

The writer received assistance from many sources in carrying out at Stanford University the study on which this report is based. Special acknowledgment is due the Consolidated Aircraft Company for the gift of the test specimens, and to the National Advisory Committee for Aeronautics for the financial assistance that made possible a more thorough study than could otherwise have been contemplated. Acknowledgment is also made to Messrs. Russell W. Brown, Milton A. Miner, and Permit E. Van Every, former graduate students on whose theses this report is largely based, as well as to the students who assisted them in making their tests; Normal Christensen, Roy P. Jackson, and Milton A. Miner are to be thanked for their assistance in carrying out the third group of tests of panels in axial compression and for the calculation of the results of the tests. Messrs. Roy A. Miller and K. R. Jackman of the Consolidated Aircraft Corporation and Professors Merrill S. Hugo, S. Timoshenko, and Harry A. Williams of Stanford University are to be thanked for technical advice and assistance, and Messrs. O. G. Warm, W. H. Cadwell, F. D. Banham, R. H. Harcourt, W. W. Young, and T. J. Palmateer of Stanford University for assistance in the design and construction of test apparatus.

#### TEST MATERIAL

All stiffeners were formed on a brake from strips of 24S-0 material 0.064 inch thick and 2.52 inches wide. The dimensions of the stiffener sections and the corresponding section characteristics are shown in figure 1. The stiffeners tested individually were in lengths of 16 and 24 inches.

The stiffeners were heat treated, age hardened three days, and stretched to 3 percent permanent set in the straightening operation. The material then had the following properties:

|   |            |
|---|------------|
| Yield stress in tension, lb/sq in. . . . .    | 56,000     |
| Ultimate stress in tension, lb/sq in. . . . . | 68,000     |
| Elongation in 2 in., percent . . . . .        | 15 to 17   |
| Young's modulus, lb/sq in. . . . .            | 10,300,000 |

These values were supplied by the Consolidated Aircraft Corporation and verified at Stanford University within one-half of 1 percent by a standard tensile test. In this test two Huggenberger tensometers with 1-inch gage lengths were used to measure the strains of a carefully milled specimen cut from stiffener D-2. Load was applied by a 20,000-pound Tinius Olsen universal testing machine.

The panels were fabricated with 0.025-inch 24S-T sheet with the grain parallel to the stiffeners. Each panel had three stiffeners riveted to the sheet with 3/32-inch A 17S-T rivets (Lockheed Standard - Brazier - LS - 1100 - 7/32 inch long, age hardened eight days before driving). The rivet spacing was 3/4 inch with the end rivets 1/4 inch from the end of the specimen. Stiffener spacings of 4, 6, 8, and 10 inches (rivet line to rivet line) were provided. Panel lengths of both 16 and 24 inches were used. The panels were supplied in "duplicate" pairs, but one of the 24-inch panels and 12 of the 16-inch panels were not tested. The other panels, 31 of 24-inch length and 20 of 16-inch length, were tested in compression. At least one panel of each size was tested. In each panel the sheet was trimmed flush with the outside of the edge stiffeners, and the ends were carefully ground plane to within 0.002 inch over the entire width and as nearly parallel to each other as possible.

Both sheet and stiffeners were weighed prior to drilling and the sectional areas of each were computed, a density of 0.1 pound per cubic inch being assumed. The observed weights and computed sectional areas are listed in table 1. During the tests, numerous check measurements were made on the test material. Measurements of thickness, over-all width, and height of the section were taken at 4-inch intervals along the lengths of the individual stiffeners and, in the case of the S section, the angle between web and flanges was also measured. For many of the panels, these measurements were supplemented by measurement of sheet thickness taken along the panel width and

length. The results were averaged and used for an independent computation of sectional areas. Most of the linear dimensions of each specimen were within 2 percent of the average, but the angle of the web of the S section was not under such close control. It varied as much as 4 percent within a specimen and also 4 percent from the value needed to make one principal axis parallel to the flanges.

The computed areas based on these measured dimensions and the areas based on weights were usually in close agreement, the maximum difference being 0.038 square inch and the median difference 0.009 square inch.

In addition to variations within a specimen the dimensions differed from the nominal. Study of half of the 24-inch panels revealed variations in sheet thickness between -4.4 and +8.8 percent from the nominal, the median figure being +1.6 percent. Stiffener thickness deviated between -2.5 and +7.8 percent from the nominal and there was no deviation of the median. The moments of inertia of the stiffener showed somewhat larger deviations from the nominal, which amounted in some cases to as much as 12 percent. The deviations from nominal dimensions of the other specimens were of the same order of magnitude. The action of the panels under test, however, indicated that the deviations, from nominal in moment of inertia were of much less influence on the results than those in sectional area. Although some of these deviations from nominal may appear rather large, they are less than deviations likely to be encountered in actual construction and are representative of good shop practice. Although they prevent too fine distinctions being drawn from the test results, they do not prevent useful practical conclusions being drawn.

#### APPARATUS AND TEST PROCEDURE

Simple bending tests.— Eleven of the 24-inch panels were tested as simply supported beams with concentrated loads at the midspan. The test apparatus is shown in figures 2 to 5. The entire testing equipment was set up on the heavy plywood base mounted on a pair of wood horses shown in figure 2. The plywood base was drilled to allow steel rods to transmit the load from the lever system below the base to the panel, which was supported on rods resting in V blocks. These end-support rods were of

1-inch diameter cold-rolled steel. They were properly spaced under the ends of the panel by steel templates, which located each end support  $10.75 \pm 0.05$  inches from the center of the specimen. One of the support rods was mounted on small roller pads to permit horizontal travel; the other rod was fixed.

Figure 4 shows diagrammatically the method of loading a panel in simple bending. The load is divided into three equal parts by a lever arrangement, the loads being 25-pound bags of shot. This lever system was designed to fit all four stiffener spacings (from 4 to 10 in.) by relocating the hinge pins in the levers. When panels reinforced by C and S stiffeners with the skin in compression were being tested, the loading rods could not be fastened directly to the steel blocks. The loads were therefore transmitted through the C-shape fittings shown in figure 5.

Deflections of the stiffeners were measured by dial gages. The gages at the ends (directly above the end supports) were individually mounted on adjustable stands and those measuring deflections near the center were mounted on a single large hanger, likewise adjustable. This large standard provided also a means of mounting the scale for measuring stiffener twist with the aid of aluminum-alloy pointers. The pointers, about 10 inches long, were glued to each stiffener at the center of the panel, as shown in figures 2 and 3. In some preliminary tests it had been found that local deformation near the points of load application seriously affected the validity of the deflection readings taken at the center of the span. The center-deflection readings were therefore taken at points  $1\frac{1}{2}$  inches from midspan.

In the panel bending tests, the dial gages were set to zero and the initial pointer readings were made with the specimen under a tare load of 26 pounds. Load was then applied in increments, usually of 100 pounds, until the total load amounted to from 226 to 376 pounds, depending on the stiffness of the specimen. The load was then removed in 50 pound decrements. Dial-gage and pointer readings were taken after each change in load, but only those readings obtained in the unloading process were used to plot the curves from which the panel stiffnesses were computed.

Compression tests.— Three sets of compression tests to destruction were made on panels. In the first set one

each of the 24-inch panels and one each of the 16-inch panels with 4-inch stiffener spacing, 20 in all, were tested. In the second set, the duplicates of the 24-inch panels, with the exception of the panel with U stiffeners and 4-inch spacing, a total of 15 panels, were tested. The third set was composed of one of each of the 16-inch panels, 16 in all. Those panels with the 4-inch stiffener spacing were duplicates of panels of the first set; the others were panels of which duplicates were not tested.

All the compression tests were made in a Tinius Olsen, hand-operated, 30,000-pound universal testing machine equipped with extension rods. In order to adapt this machine for panel testing, two case-hardened platens, shown in figure 6, were made. The upper platen was finished from a mild steel block 4 by 4 by 28 inches and the lower platen from a mild steel block 1 by 4 by 28 inches. Both pieces were milled approximately plane, case-hardened ground plane and parallel within 0.001 inch, and lapped plane and parallel using a third surface.

A system of bracing to stabilize and guide the motion of the upper platen was run from the upper platen to a nearby H column, as shown in figure 6. This bracing was chiefly effective in preventing rotation and movement of the upper platen normal to the plane of the panel. No special provision was necessary to prevent movement of the upper platen parallel to the plane of the panel. Although this arrangement was crude and left much to be desired, it afforded reasonably satisfactory stability. To check on the behavior of the upper platen during the tests, deflection measurements relative to the lower platen were taken at three points on the under surface. Thus, the deviation of the two platens from parallelism could always be determined. These measurements also provided a means of measuring the total strain and the corresponding apparent average stress at each stage of the test.

One of the chief objectives of the tests was to determine any differences in the tendencies of the different types of stiffeners to twist under load. For this purpose aluminum pointers about 1 foot long were glued to each stiffener near midheight, and a scale placed in a convenient position for measuring the movements of their free ends. These pointers and the scale are shown in figure 7.

When possible, stiffener elongations were obtained by Huggenberger tensometers having a gage length of 1 inch.

The movement of the pointers of these gages were read to 0.01 inch, which indicated a strain of  $1/120,000$ .

Some secondary apparatus and gages, which appear in figures 7 and 8, were used for measurements from which it was hoped to be able to compute the actual degree of restraint of the stiffeners considered as columns. As this phase of the investigation, however, produced no results suitable for publication, the data obtained and the methods used for obtaining them are omitted from this report.

The methods of positioning the specimen and carrying out the tests varied in detail among the three sets of tests. In all three sets, however, the specimen was first placed between the platens and held with a light load while its position was checked for continuity of contact with the platens. The load was next increased several thousand pounds and then reduced to an initial load of from 2000 to 3000 pounds. If, during this process of loading and unloading, the indications of lack of uniform distribution were not excessive in magnitude, the position of the specimen was considered satisfactory. The criteria for satisfactory specimen location differed quantitatively between the test groups, but, in general, a difference of 0.002 inch between the readings of the gages measuring the vertical movement of the upper platen with respect to the lower was the maximum allowed. Because two of these gages were nearly 28 inches apart, the permissible relative rotation of the platens about an axis normal to the plane of the specimen was very small. In the second and third groups of tests, tensometers were also attached to the edge stiffeners and the permissible difference between their readings was held to a fraction of a scale division. If the difference in platen movement or tensometer readings indicated excessive differences between the loads carried by the edge stiffeners, the position of the specimen was changed until a satisfactory position was obtained.

When the specimen had been satisfactorily placed in the testing machine, all measuring devices not previously applied were attached and the main test run was started. At first, loads were imposed in equal increments of 1000, 1500, or 2000 pounds, but, as the ultimate load was approached, the testing machine was kept balanced as nearly as possible and stopped for observations after selected increments of specimen shortening or when the beam dropped suddenly because of the yielding of the panel. Before the ultimate load was reached, the tensometers and such dial gages as might be injured by the failure of the specimen were removed.

In the first set of tests, relatively little attention was paid to the action of the panels after the maximum load had been reached. In the second and particularly in the third set of tests, much more attention was paid to the action of the panels at that stage.

After failure of one or more elements of the panel, travel of the loading head was continued to permit observation of the action of the other elements. The variations of load carried as failure progressed were recorded and notes were taken of the types and locations of failure. For a few specimens of the second set (24-inch panels with 10-inch stiffener spacing) photographs were taken of the panel under the initial load of 3,000 pounds, at failure, and after failure when the load had been reduced to 3,000 pounds. These photographs give evidence of the type and magnitude of the failure. In the third set of tests, after the load had dropped to about three-quarters of the ultimate (in three cases it suddenly dropped to a much smaller fraction), the test was stopped and a photograph was taken of the panel to illustrate the character of the deformation.

One 16-inch and one 24-inch length of each stiffener section was tested to failure as a flat-end column. The apparatus and procedure used in these tests were the same, as far as applicable, as for the compression tests of panels. More detailed description of these tests is therefore considered unnecessary.

#### PRECISION

To assure uniform distribution of the load, the platens were lapped plane within 0.0005 inch. During the tests of the first two groups the relative movements of the ends of the platens (about 28 in. apart) did not differ by more than 0.0030 inch prior to yielding of the specimen, which represented a relative angular movement of only about 0.0001 radian, or 0.006°. For a panel with 4-inch stiffener spacing and 16-inch length, this condition would represent an increase in the axial stress of 0.0001 by 4 by  $10,300,000/16 = 258$  pounds per square inch. In the third group of tests of the platens were not kept so closely parallel, but the uniformity in stiffener stresses was continuously checked by the tensometers and the results of the tests of 16-inch panels with 4-inch stiffener spacing are in such close agreement with those

of the corresponding panels of the first group as to give confidence in them. Measurement of the twist of the stiffeners as obtained from the pointer readings was precise to within  $\pm 0.002$  radian. This value was an appreciable fraction of most of these rotation readings, since the latter were so small, but the precision was adequate for qualitative results and conclusions.

The Tinius Olsen testing machine was graduated to the nearest 5 pounds, but difficulty of keeping the beam in exact balance reduced the precision of the load readings to about  $\pm 50$  pounds when the beam had to be kept in balance while the strain was being increased. The machine itself was known to be accurate to within plus or minus one-half of 1 percent. On the whole, the precision of total loads may be assumed to be  $\pm 0.75$  percent; whereas differences between loads of about the same magnitude recorded for a given test are correct to within  $\pm 50$  pounds if it were in motion when the reading was taken.

#### SYMBOLS

|          |   |
|----------|---|
| b        | width of panel between stiffeners, inches                       |
| L        | length of panel, inches   |
| s        | developed length of center line of stiffener, inches            |
| t        | thickness of stiffener, inch                                    |
| A        | stiffener cross-sectional area, square inches                   |
| r        | inside radius of bends, inches                                  |
| I        | moment of inertia about stiffener centroid, inches <sup>4</sup> |
| $\delta$ | panel deflection in bending, at panel center, inches            |
| E        | modulus of elasticity   |
| P        | compressive load, pounds  |
| W        | bending load, pounds  |
| EI       | flexural rigidity   |

## TEST RESULTS

Panel bending tests.— In the panel bending tests the deflection of a point near the center of each stiffener from a line joining the points of support was determined by subtracting the gage reading at that point from the average of the gage readings at the supports. The resulting center-stiffener deflections were plotted as shown in figure 9 against load per stiffener and straight lines fitted as closely as possible to the plotted points. The slope of this line for each stiffener was then determined, to find the ratio of load to deflection  $W/\delta$ . For the dimensions of the test set-up, the ordinary formula for beam deflection reduced to  $EI = 201.6 W/\delta$ . The values of  $EI$  obtained from this expression are recorded in table 2, in which  $EI_1$  and  $EI_3$  are the observed stiffnesses of the edge stiffeners and  $EI_2$  that of the center stiffener. For purposes of comparison the table includes the computed values of  $EI$  for the center stiffener based on measurements of the actual cross section and an assumed value of 10,300,000 pounds per square inch for  $E$ . This table includes also the maximum load imposed on the panel in each test.

In addition to the measurements of deflection, the movements of the free ends of the pointers glued to the stiffener webs were recorded in order to obtain information regarding the tendency of the stiffeners to twist. For most of the panels, this procedure was followed only when the panel was tested with the skin in tension, on account of the difficulty of obtaining the information when the stiffeners were below the sheet. With panel PA 16, however, these readings were taken for the two edge stiffeners. Table 3 shows the length of the pointer, and the total movement of the free end of the pointer in inches. The plus and minus signs indicate whether the reading of the pointer on the scale increased or decreased with increase in load. In some cases, the movement of the pointer changed in direction and this change is indicated by the symbol  $\pm$ .

Panel compression tests.— The maximum axial loads carried and the types of failure exhibited by the various panels are summarized in tables 4 and 5. These tables include also two values of unit stress corresponding to each ultimate load. One is the average stress obtained by dividing the load by the total sectional area of the panel from table 1. The other is the load divided by the sectional area of the

stress carried by the panel because the first computation uses too much and the second, too little of the area of the sheet.

For each test the recorded readings of the gages that measured the movement of the upper platen were used to obtain curves of average panel shortening against axial load, as shown in figure 10. First the actual gage readings were plotted against load and the movements of the three gages were shown by curves 1, 2, and 3. These curves were extrapolated to zero load to determine the shortening which took place between zero load and the load at which the first measurements were taken. Since the lower portions of the basic curves were quite straight, this extrapolation could be done with satisfactory precision. The readings for each load were then averaged, the estimated shortening at the initial load added, and the "average curve" drawn. Since two gages were at one end of the platen and only one was at the other end, the reading of the single gage was given double weight in computing the average. The average shortenings of the different panels under a group of representative loads, as obtained from these curves, are listed in tables 6 and 7.

The approach of failure of all the panels was indicated by definite signs. The sheet used in their fabrication was so thin that, even under the initial loads, it normally exhibited buckles in the areas between stiffeners. These buckles grew as the load increased, but little attention was paid to the details of the development, since that type of action has been studied more carefully by Ramberg, McPherson, and Levy in reference 3 and by other experimenters. Since this buckling was present throughout the tests, it could hardly be considered a true indication of impending failure.

The first sign of impending failure was usually the buckling of the skin between rivets connecting it to the stiffeners. This buckling could seldom be seen at the center stiffener, but was easily visible at the edge stiffeners. Often this condition became noticeable on both edges at the same load, though in many tests it was seen on one edge before on the other. These buckles developed so gradually that it was difficult to know just when they began to appear. The loads at which they were noted in the third set of tests are recorded in table 8. The corresponding data for the other two sets of tests are not so complete, but there appeared to be little difference in the range of loads at which this wrinkling first became noticeable between the 16- and the 24-inch panel groups.

As the strain was further increased the free edges of the stiffeners on some specimens began to appear wavy and later developed definite buckles, at which points failure subsequently took place. This waviness did not become apparent on many of the panels, however, until after the maximum load had been passed. The loads at which it was first noticed on each of the stiffeners of panels of the third group are listed in table 8. The approach of maximum load of some panels was warned by visible twisting of one or both of the edge stiffeners. The load at which this twisting was first noticed is also recorded in table 8 for the third test group. On many of the panels, however, no such stiffener twisting was noticeable, even at the end of the test. Practically no information on these points was recorded in connection with the tests of the first two groups of panels.

The best indications of approaching failure were the drop in load while the testing machine was stopped to take readings and the decrease in the rate of change of load while the testing machine was in motion. Under low loads there was no drop in the load on the specimen while a set of readings was being taken. As the loads increased, however, it was found that during the time to obtain a set of readings the equilibrium load of the panel decreased, although there was no change in the position of the upper platen. At first this decrease would be a matter of only 10 pounds or so, but with increased strain, it became progressively greater, and before a test was completed might amount to as much as 100 pounds. These effects can be seen from figure 11, which shows to enlarged scale the upper portion of a curve of representative load against axial shortening. The same figure shows how the slope of the curve progressively decreases as the maximum load is approached. In the tests this action seemed more pronounced than it does in the figure and was the most obvious sign of approaching failure.

The action of the panels of the third group of tests as the maximum load was approached and after it had been passed was closely observed. In the typical cycle of action, as the strain increased, the equilibrium load increased to a maximum and then began to decrease. At times some part of the panel gave way suddenly when the load was at a maximum, but usually there was some gradual decrease in load with increase in strain before a partial failure and sudden drop in the equilibrium load occurred. If the testing machine were stopped to permit the taking of gage

readings, as was done after each sudden drop in load or when the amount of increase in strain made such action appear advisable, the equilibrium load was found to have decreased further while the readings were being taken. As the strain was increased after the readings were taken, the cycle was repeated, starting with an increase in equilibrium load, except that, after the panel had been very badly deformed, the equilibrium load might show no such increase. The action of these panels under large strain can be followed from the record of table 9.

In this table four phases of the typical cycle are recognized and the corresponding loads are recorded. Those recorded for phase A are the ones at which the equilibrium load reached a maximum. The phase B loads are the equilibrium loads just prior to a sudden drop in that quantity. When the testing machine was stopped for readings although there had been no sudden drop in load, no figure is entered for that phase. The phase C loads are the equilibrium loads when the taking of a set of dial gage and pointer readings was started and the phase D loads, those when the set of readings had been taken and the straining of the specimen was resumed. In order to emphasize the few cycles in which there was no drop in load from the phase A maximum to the phase B load at which there was a sudden drop, the corresponding phase B loads are indicated by footnotes.

The failure history of panel PD-8 can thus be read from the table as follows: The equilibrium load increased to 20,725 pounds and then gradually decreased to 20,530 pounds, at which point the machine was stopped for readings. When the readings had been taken, it was found that the load had dropped to 20,480 pounds. With increase of strain, the load gradually rose to 21,630 pounds and then slowly dropped to 21,430 pounds when a new set of readings was taken. When these readings had been completed the load had decreased to 21,380 pounds, but with increased strain it rose to 22,020 pounds and again began to decrease gradually. At 21,895 pounds, however, there was a sudden drop of load to 20,310 pounds due to some failure in the panel. After readings of strain had been taken, the equilibrium load had further decreased to 20,270 pounds. With further increase of strain the load rose to 20,760 pounds, at which point there was a sudden failure that caused the load to drop to 6,200 pounds. The story of this panel failure is further illustrated by figure 11, which shows graphically the variation in equilibrium load with increased strain. In this figure the only fully validated points on the curve

are those plotted from the readings for phases C and D. The location of the curve between such points is hypothetical, but is believed to be, at least qualitatively, correct. The broken line in the figure indicates the slope of the load-shortening curve in the neighborhood of zero load.

For a more complete understanding of the action of the third group of panels under large strain, table 10 gives selected excerpts from the test logs. The loads at which the various events are shown in this table are those corresponding to phase C of table 9, that is, the equilibrium loads noted just before the data were recorded.

The data on the equilibrium loads after the ultimate had been passed are much less complete and reliable for the panels of the first two groups than for those of the third. Table 11 is a record of such data as could be obtained from the logs of the second group of tests. In these logs the loads for phase D are seldom entered, and no clear distinction is made between the loads for phases A and B, because the decision to make a detailed study of the question was not made until after the second group of tests had been completed.

Because of the difficulty of adequately describing the appearance of the panels at failure, a set of sequence photographs was taken of the 10-inch spacing specimens of the second test group. These photographs are shown in figures 12 to 15. The panel ready for testing and subjected to the initial load, usually 3000 pounds, is shown in each of these figures in (a). In (b) the panel is shown just after failure, and in (c) the degree to which the specimen returned to its original state is shown. Figures 16 and 17 are additional views of the failure of panel PD-16, taken at the same time as the view in figure 15(b). In the third series of tests (most of the tests of 16-in. panels), a group of photographs (figs. 18 to 33) was taken to illustrate the action of the panels after the ultimate load had been passed. After the ultimate load had been reached, the shortening was continued until the load had considerably decreased. Usually the load was reduced to about 15,000 pounds, but the amount depended somewhat on the magnitude of the ultimate. Sometimes, the panel would suddenly fail with a loud noise and the load drop to about one-half or two-thirds of the amount that it had been carrying. The photograph was then taken to show the deformation under this condition.

For a number of the tests the angular rotations of the pointers glued to the stiffeners were computed from the measured movements of their free ends and plotted against load. These curves for the third set of panels are shown in figure 34 to 37. Corresponding curves for the other panels would be very similar. In addition, the pointer rotations for each panel under three loads, including the last load before the ultimate was reached, termed the "sub-critical load" in this report, were computed and recorded in tables 12 and 13. When the pointer rotations were recorded, no correction was made for possible movement between actual zero load and the first load at which readings were taken. This omission was justified by the negligible movements recorded for the first few increments of load in every test.

The manner in which the stiffeners of each type failed when used in the panels appeared to be a characteristic of the design, which depended to some extent on the length of the panel. With only one exception, and that questionable, the failures of the Z, S, and U section stiffeners in the 16-inch panels were primarily of the local buckling type. As the load approached the ultimate, bulges formed in the flanges, eventually gave way, and thus caused the total load to drop. In panels PB-1 and PC-1, which had Z and S section stiffeners with flanges parallel to the sheet, it was noticed that the buckles in the flange adjacent to the sheet were the more pronounced and gave indications of having occurred first, although in all instances both flanges buckled in approximately the same relative location. In the other 16-inch panel tests, few notes were taken regarding the relative magnitudes of the buckles in the two flanges of a stiffener, but in several tests it was noted that the bulge in the riveted flange was larger than that in the free flange. The failures of nearly all of the C section stiffeners in the 16-inch panels, on the other hand, were primarily torsional. In the test of panel PA-8, however, the local buckling appeared to be the primary cause of failure with the twisting secondary.

In the tests of 24-inch panels, the C section stiffeners uniformly failed primarily in torsion, though in the panels with the wider stiffener spacings (panels PA-14 and PA-16) local buckling was noted as a contributory factor. In this length, the Z section (PB series) also appeared to fail primarily by twisting, though normally with accompanying local buckling. The stiffeners of S and U sections failed normally by local buckling, though twisting was also noticed in a number of the tests.

On the whole, the U section stiffeners showed the least evidence of twisting, in spite of the method used to measure that action. With the other sections, the pointers were attached to the webs and measured rotations of the whole stiffener. The pointers were attached to stiffener flanges of the U section and in some tests appeared to measure flange rotation due to local buckling rather than rotation of the stiffener section as a whole.

The failures of most of the panels after passing maximum load were gradual, the panels exhibiting a remarkable ability to be deformed without much drop in the equilibrium load. Some of the panels with U section stiffeners, however, failed rather suddenly. The failures of the two 24-inch panels with 10-inch stiffener spacing (PD-15 and PD-16) were very similar. At maximum load the edge stiffeners suddenly twisted in toward the center stiffener. The failure was accompanied by a loud noise and a much larger drop in equilibrium load than was experienced for any of the other 24-inch panels. In the 16-inch panel tests, also, the U section panels showed a tendency to complete and sudden collapse at final failure, such behavior shown by three of the five panels tested. In this length tendency to the explosive type of failure took place with spacings of 4, 6, and 10 inches and did not take place with the 8-inch or the duplicate 4-inch spacing panel. In one respect the violent failures of the shorter panels differed from those of the longer ones. Instead of taking place under the maximum load, failure did not occur until the equilibrium load had passed the maximum and had experienced an appreciable drop.

Column tests of individual stiffeners.— The ultimate loads and corresponding unit stresses of the individual stiffeners tested as flat-end columns are listed in table 14. In these tests measurements of midpoint rotation and change in slope near the ends were made in order to determine from them the actual degree of end restraint, but the applicability of the method proved questionable and those data were not used.

The shorter Z (E-1) failed by local buckling following some plastic bending about its axis of minimum stiffness. The S section of the same length (C-1) showed a gradual plastic bending over a considerable portion of its length. The shorter channel (D-1) failed primarily by twisting. The ends of this specimen remained flat against the platens and the distorted column axis formed a single

large symmetrical sinusoidal wave with rather definite points of inflection. In the longer lengths both the Z and S sections (E-5 and C-5) failed in the manner characteristic of long columns, deflecting in the directions of the minor axes of the cross sections and exhibiting little tendency to twist. The longer channel (D-5) failed torsionally in the same manner as the shorter one (D-1).

Stanford University,

Stanford University, Calif., July 29, 1942.

#### REFERENCES

1. Carah, A. J., and Park, J. W.: Elastic Properties of Light Alloy Channels. Standard Univ. Thesis, 1938.
2. Younger, John H., Fonnelle, Allen F., and Ward, Hairne, F.: Airplane Maintenance. McGraw-Hill Book Co., Inc., 1937.
3. Ramberg, Walter, McPherson, Albert E., and Levy, Sam: Experimental Study of Deformation and of Effective Width in Axially Loaded Sheet-Stringer Panels. T.N. No. 684, NACA, 1959.

TABLE 1.- PANEL WEIGHTS AND DIMENSIONS.

| Panel | Type<br>Stiff-<br>ener | Length<br>(in.) | Stiff-<br>ener<br>spacing<br>(in.) | Weight<br>(grams) |                | Sectional area<br>(sq in.) |                |       |
|-------|------------------------|-----------------|------------------------------------|-------------------|----------------|----------------------------|----------------|-------|
|       |                        |                 |                                    | Sheet             | Stiff-<br>ener | Sheet                      | Stiff-<br>ener | Total |
| PA -1 | C                      | 16              | 4                                  | 177               | 345.5          | 0.244                      | 0.475          | 0.719 |
| PA -2 | C                      | 16              | 4                                  | 165               | 344            | .228                       | .474           | .702  |
| PA -4 | C                      | 16              | 6                                  | 236               | 343.5          | .324                       | .472           | .796  |
| PA -6 | C                      | 16              | 8                                  | 324               | 345.5          | .446                       | .475           | .921  |
| PA -8 | C                      | 16              | 10                                 | 389               | 343.5          | .536                       | .472           | 1.008 |
| PA- 9 | C                      | 24              | 4                                  | 233               | 513.5          | .214                       | .471           | .685  |
| PA-10 | C                      | 24              | 4                                  | 242               | 507.5          | .222                       | .466           | .688  |
| PA-11 | C                      | 24              | 6                                  | 339.5             | 512            | .311                       | .470           | .781  |
| PA-12 | C                      | 24              | 6                                  | 345               | 515.5          | .316                       | .472           | .788  |
| PA-13 | C                      | 24              | 8                                  | 477.5             | 523.5          | .438                       | .480           | .918  |
| PA-14 | C                      | 24              | 8                                  | 472               | 507.5          | .433                       | .466           | .899  |
| PA-15 | C                      | 24              | 10                                 | 591.5             | 511.5          | .543                       | .463           | 1.012 |
| PA-16 | C                      | 24              | 10                                 | 580               | 515.5          | .532                       | .472           | 1.004 |
| PB -1 | Z                      | 16              | 4                                  | 169               | 331            | .234                       | .455           | .689  |
| PB -2 | Z                      | 16              | 4                                  | 168.5             | 331.5          | .232                       | .456           | .688  |
| PB -4 | Z                      | 16              | 6                                  | 238.5             | 349.5          | .328                       | .481           | .809  |
| PB -6 | Z                      | 16              | 8                                  | 330               | 331            | .455                       | .455           | .910  |
| PB -8 | Z                      | 16              | 10                                 | 393.5             | 332.5          | .543                       | .458           | 1.001 |
| PB -9 | Z                      | 24              | 4                                  | 250               | 491            | .229                       | .450           | .679  |
| PB-10 | Z                      | 24              | 4                                  | 226.5             | 493.5          | .208                       | .453           | .661  |
| PB-11 | Z                      | 24              | 6                                  | 343.5             | 495            | .315                       | .454           | .769  |
| PB-12 | Z                      | 24              | 6                                  | 347               | 500            | .318                       | .459           | .777  |
| PB-13 | Z                      | 24              | 8                                  | 463.5             | 500            | .425                       | .459           | .884  |
| PB-14 | Z                      | 24              | 8                                  | 467               | 496.5          | .429                       | .456           | .885  |
| PB-15 | Z                      | 24              | 10                                 | 583               | 501.5          | .535                       | .460           | .995  |
| PB-16 | Z                      | 24              | 10                                 | 581               | 497            | .533                       | .456           | .989  |
| PC -1 | S                      | 16              | 4                                  | 159.5             | 347.5          | .220                       | .478           | .698  |
| PC -2 | S                      | 16              | 4                                  | 164               | 346.5          | .226                       | .477           | .703  |
| PC -4 | S                      | 16              | 6                                  | 235.5             | 342            | .325                       | .471           | .796  |
| PC -6 | S                      | 16              | 8                                  | 309               | 333.5          | .427                       | .459           | .886  |
| PC -8 | S                      | 16              | 10                                 | 372.5             | 346            | .514                       | .473           | .990  |
| PC -9 | S                      | 24              | 4                                  | 232               | 517            | .213                       | .474           | .687  |
| PC-10 | S                      | 24              | 4                                  | 235               | 516.5          | .215                       | .474           | .690  |
| PC-11 | S                      | 24              | 6                                  | 348.5             | 515            | .319                       | .473           | .792  |
| PC-12 | S                      | 24              | 6                                  | 352               | 511            | .325                       | .469           | .792  |
| PC-13 | S                      | 24              | 8                                  | 456               | 513.5          | .418                       | .473           | .890  |
| PC-14 | S                      | 24              | 8                                  | 457.5             | 517            | .420                       | .474           | .894  |
| PC-15 | S                      | 24              | 10                                 | 576.5             | 504.5          | .529                       | .463           | .992  |
| PC-16 | S                      | 24              | 10                                 | 578               | 500.5          | .530                       | .459           | .980  |
| PD -1 | U                      | 16              | 4                                  | 164               | 348            | .226                       | .479           | .705  |
| PD -2 | U                      | 16              | 4                                  | 163.5             | 353            | .230                       | .485           | .715  |
| PD -4 | U                      | 16              | 6                                  | 237.5             | 345            | .328                       | .473           | .803  |
| PD -6 | U                      | 16              | 8                                  | 290               | 344            | .400                       | .474           | .874  |
| PD -8 | U                      | 16              | 10                                 | 396               | 345            | .546                       | .473           | 1.021 |
| PD -9 | U                      | 24              | 4                                  | 240               | 520            | .220                       | .477           | .697  |
| PD-11 | U                      | 24              | 6                                  | 369               | 509            | .339                       | .467           | .806  |
| PD-12 | U                      | 24              | 6                                  | 345.5             | 501            | .317                       | .461           | .778  |
| PD-13 | U                      | 24              | 8                                  | 464               | 513.5          | .428                       | .472           | .898  |
| PD-14 | U                      | 24              | 8                                  | 471               | 514            | .432                       | .472           | .904  |
| PD-15 | U                      | 24              | 10                                 | 589               | 515            | .541                       | .473           | 1.014 |
| PD-16 | U                      | 24              | 10                                 | 593               | 513            | .544                       | .471           | 1.015 |

TABLE 2.- PANEL STIFFNESS FROM SIMPLE BENDING TESTS.

| Stiffener spacing (in.) | Panel | Measured $I_2$ (a) | Computed $EI_2$ (b) | Maximum load | Experimentally determined EI values <sup>c</sup> |        |        |                      |        |        |
|-------------------------|-------|--------------------|---------------------|--------------|--|--------|--------|----------------------|--------|--------|
|                         |       |                    |                     |              | Sheet in tension                                 |        |        | Sheet in compression |        |        |
|                         |       |                    |                     |              | $EI_1$   | $EI_2$ | $EI_3$ | $EI_1$               | $EI_2$ | $EI_3$ |
| 4                       | PA-10 | 0.0291             | 300                 | 276          | 130  | 202    | 181    | 134                  | 173    | 144    |
|                         | PB-10 | .0307              | 316                 | 376          | 350  | 379    | 389    | 270                  | 319    | 347    |
|                         | PC-10 | .0319              | 329                 | 276          | 430  | 442    | 439    | 387                  | 419    | 419    |
| 6                       | PA-12 | .0312              | 321                 | 326          | 153  | 237    | 201    | 169                  | 200    | 147    |
|                         | PB-12 | .0328              | 338                 | 326          | 357  | 451    | 418    | 389                  | 352    | 262    |
|                         | PC-12 | .0323              | 335                 | 351          | 464  | 507    | 447    | 439                  | 445    | 410    |
|                         | PD-12 | .0118              | 122                 | 276          | 175  | 196    | 179    | 164                  | 171    | 165    |
| 8                       | PA-14 | .0279              | 287                 | 276          | 155  | 194    | 179    | 113                  | 186    | 173    |
|                         | PC-14 | .0341              | 351                 | 376          | 427  | 550    | 422    | 409                  | 432    | 389    |
|                         | PD-14 | .0115              | 118                 | 276          | 149  | 185    | 161    | 169                  | 169    | 157    |
| 10                      | PA-16 | .0311              | 320                 | 226          | 143  | 211    | 185    | 127                  | 224    | 142    |

<sup>a</sup>"Measured  $I_2$ " in column 3 is the moment of inertia of the center stiffener about a centroidal axis parallel to the sheet, computed from measurements of the actual stiffener.

<sup>b</sup>"Computed  $EI_2$ " in column 4 is the value in column 3 multiplied by 10,300. Tabulated values are in thousands of pound-inch units.

<sup>c</sup>"Experimentally determined EI values" in columns 6 to 11 are computed from the slopes of the load-deflection curves of the individual stiffeners, using the relation  $EI = 201.6W/\delta$ .  $EI_1$  and  $EI_3$  pertain to the edge and  $EI_2$  to the center stiffener. Tabulated values are in thousands of pound-inch units.

TABLE 3.- STIFFENER TWIST OF PANELS IN BENDING.

[Rotation is positive when pointer readings increase with increase in load. Plus or minus sign indicates that a change in direction of motion was noted.]

| Panel                | Arm length (in.) | Total load (lb) | Movement of end of pointer |              |              |
|----------------------|------------------|-----------------|----------------------------|--------------|--------------|
|                      |                  |                 | 1 (in.)                    | 2 (in.)      | 3 (in.)      |
| Sheet in Tension.    |                  |                 |                            |              |              |
| PA - 10              | 10-5/8           | 276             | +0.80                      | +0.40        | +0.47        |
| PB - 10              | 10-1/4           | 350             | - .05                      | <u>±</u> .04 | <u>±</u> .05 |
| PC - 10              | 10               | 326             | + .05                      | + .09        | + .02        |
| PA - 12              | 10               | 326             | + .99                      | + .46        | + .50        |
| PB - 12              | 9-3/4            | 326             | <u>±</u> .09               | <u>±</u> .03 | - .10        |
| PC - 12              | 10-3/4           | 351             | <u>±</u> .02               | <u>±</u> .01 | - .12        |
| PD - 12              | 9-3/4            | 276             | + .11                      | - .03        | - .05        |
| PA - 14              | 10-3/4           | 276             | + .90                      | + .49        | + .53        |
| PC - 14              | 10               | 376             | + .23                      | + .09        | - .16        |
| PD - 14              | 8-3/4            | 276             | + .22                      | + .08        | <u>±</u> .05 |
| PA - 16              | 10-1/4           | 226             | + .75                      | + .40        | + .40        |
| Sheet in Compression |                  |                 |                            |              |              |
| PA - 16              | 4-1/2            | 226             | +0.37                      | not recorded | +0.37        |

TABLE 4.- ULTIMATE LOADS AND UNIT STRESSES ON 24-INCH PANELS.

| Panel                     | Ultimate load<br>(lb) | Stiffener area<br>(sq in.) | Average stiffener stress<br>(lb/sq in.) | Total area<br>(sq in.) | Average ultimate stress<br>(lb/sq in.) | Percentage variation |                | Test group | Type of failure <sup>a</sup> |
|---------------------------|-----------------------|----------------------------|---|------------------------|--|----------------------|----------------|------------|------------------------------|
|                           |                       |                            |   |                        |  | Ultimate load        | Average stress |            |                              |
| 4-inch stiffener spacing  |                       |                            |   |                        |  |                      |                |            |                              |
| PA- 9                     | 16,200                | 0.471                      | 34,400                                  | 0.685                  | 23,600                                 | -1.2                 | -1.3           | 1          | T                            |
| PA-10                     | 16,000                | .466                       | 34,300                                  | .688                   | 23,300                                 |                      |                | 2          | T                            |
| PB- 9                     | 17,200                | .450                       | 38,200                                  | .679                   | 25,300                                 | - .5                 | 2.4            | 1          | T,L                          |
| PB-10                     | 17,120                | .453                       | 37,800                                  | .661                   | 25,900                                 |                      |                | 2          | T,L                          |
| PC- 9                     | 20,800                | .474                       | 43,900                                  | .687                   | 30,300                                 | -1.7                 | -2.3           | 1          | L                            |
| PC-10                     | 20,450                | .474                       | 43,100                                  | .690                   | 29,600                                 |                      |                | 2          | L,T                          |
| PD -9                     | 18,400                | .477                       | 38,600                                  | .697                   | 26,400                                 |                      |                | 1          | L                            |
| 6-inch stiffener spacing  |                       |                            |   |                        |  |                      |                |            |                              |
| PA-11                     | 14,600                | .470                       | 31,100                                  | .781                   | 18,700                                 | 8.9                  | 8.0            | 1          | T                            |
| PA-12                     | 15,900                | .472                       | 33,700                                  | .788                   | 20,200                                 |                      |                | 2          | T                            |
| PB-11                     | 16,500                | .454                       | 36,300                                  | .769                   | 21,400                                 | 6.1                  | 5.1            | 1          | T,B                          |
| PB-12                     | 17,500                | .459                       | 38,100                                  | .777                   | 22,500                                 |                      |                | 2          | T,L                          |
| PC-11                     | 21,000                | .473                       | 44,400                                  | .792                   | 26,500                                 | -2.6                 | -2.6           | 1          | L                            |
| PC-12                     | 20,450                | .469                       | 43,600                                  | .792                   | 25,800                                 |                      |                | 2          | L,T                          |
| PD-11                     | 18,400                | .467                       | 39,400                                  | .806                   | 22,800                                 | -2.3                 | 1.3            | 1          | L                            |
| PD-12                     | 17,985                | .461                       | 39,000                                  | .778                   | 23,100                                 |                      |                | 2          | L                            |
| 8-inch stiffener spacing  |                       |                            |   |                        |  |                      |                |            |                              |
| PA-13                     | 17,100                | .480                       | 35,600                                  | .918                   | 18,600                                 | -11.7                | -9.7           | 1          | T                            |
| PA-14                     | 15,100                | .466                       | 32,400                                  | .899                   | 16,800                                 |                      |                | 2          | T,L                          |
| PB-13                     | 17,900                | .459                       | 39,000                                  | .884                   | 20,200                                 | - .9                 | -1.0           | 1          | T,L                          |
| PB-14                     | 17,740                | .456                       | 38,900                                  | .885                   | 20,000                                 |                      |                | 2          | T,L                          |
| PC-13                     | 20,800                | .472                       | 44,000                                  | .890                   | 23,400                                 | 1.6                  | .9             | 1          | L,T                          |
| PC-14                     | 21,135                | .474                       | 44,600                                  | .894                   | 23,600                                 |                      |                | 2          | L                            |
| PD-13                     | 18,000                | .472                       | 38,100                                  | .898                   | 20,000                                 | 1.2                  | 1.0            | 1          | L                            |
| PD-14                     | 18,210                | .472                       | 38,600                                  | .904                   | 20,200                                 |                      |                | 2          | T,L                          |
| 10-inch stiffener spacing |                       |                            |   |                        |  |                      |                |            |                              |
| PA-15                     | 15,600                | .469                       | 33,300                                  | 1.012                  | 15,400                                 | -4.6                 | -3.9           | 1          | T                            |
| PA-16                     | 14,875                | .472                       | 31,500                                  | 1.004                  | 14,800                                 |                      |                | 2          | T,L                          |
| PB-15                     | 17,300                | .460                       | 37,600                                  | .995                   | 17,400                                 | 5.7                  | 6.3            | 1          | T                            |
| PB-16                     | 18,280                | .456                       | 40,100                                  | .989                   | 18,500                                 |                      |                | 2          | T,L                          |
| PC-15                     | 20,000                | .463                       | 43,200                                  | .992                   | 20,200                                 | - .2                 | 0              | 1          | L,T                          |
| PC-16                     | 19,950                | .459                       | 43,500                                  | .989                   | 20,200                                 |                      |                | 2          | L                            |
| PD-15                     | 17,500                | .473                       | 37,000                                  | 1.014                  | 17,500                                 | .6                   | 0              | 1          | L,T                          |
| PD-16                     | 17,600                | .471                       | 37,300                                  | 1.015                  | 17,300                                 |                      |                | 2          | L,T                          |

<sup>a</sup>Notation of types of failure:

B, bending

L, local buckling

T, torsional

Where two types of failure were observed in the same test, the one that seemed to be the primary type is listed first.

TABLE 5.- ULTIMATE LOADS AND UNIT STRESSES FOR 16-INCH PANELS.

| Panel                     | Ultimate load<br>(lb) | Stiffener area<br>(sq in.) | Average stiffener stress<br>(lb/sq in.) | Total area<br>(sq in.) | Average ultimate stress<br>(lb/sq in.) | Percent variation |                | Test group | Type of failure<br>(a) |
|---------------------------|-----------------------|----------------------------|---|------------------------|--|-------------------|----------------|------------|------------------------|
|                           |                       |                            |   |                        |  | Ultimate load     | Average stress |            |                        |
| 4-inch stiffener spacing  |                       |                            |   |                        |  |                   |                |            |                        |
| PA-1                      | 19,500                | 0.475                      | 41,000                                  | 0.719                  | 27,100                                 | -1.5              | 1.1            | 1          | T                      |
| PA-2                      | 19,200                | .474                       | 40,500                                  | .702                   | 27,400                                 |                   |                | 3          | T                      |
| PB-1                      | 19,000                | .455                       | 41,800                                  | .689                   | 27,600                                 | .3                | .4             | 1          | L                      |
| PB-2                      | 19,050                | .456                       | 41,800                                  | .688                   | 27,700                                 |                   |                | 3          | L,T                    |
| PC-1                      | 21,700                | .478                       | 45,400                                  | .698                   | 31,100                                 | .5                | .3             | 1          | L                      |
| PC-2                      | 21,800                | .477                       | 45,700                                  | .703                   | 31,000                                 |                   |                | 3          | L                      |
| PD-1                      | 21,400                | .479                       | 44,700                                  | .705                   | 30,300                                 | 2.9               | 1.6            | 1          | L                      |
| PD-2                      | 22,020                | .485                       | 45,400                                  | .715                   | 30,800                                 |                   |                | 3          | L                      |
| 6-inch stiffener spacing  |                       |                            |   |                        |  |                   |                |            |                        |
| PA-4                      | 18,800                | .472                       | 39,800                                  | .796                   | 23,600                                 |                   |                | 3          | T                      |
| PB-4                      | 21,100                | .481                       | 43,800                                  | .809                   | 26,100                                 |                   |                | 3          | T,L                    |
| PC-4                      | 21,475                | .471                       | 45,600                                  | .796                   | 27,000                                 |                   |                | 3          | L                      |
| PD-4                      | 22,225                | .475                       | 46,800                                  | .803                   | 27,700                                 |                   |                | 3          | L                      |
| 8-inch stiffener spacing  |                       |                            |   |                        |  |                   |                |            |                        |
| PA-6                      | 19,520                | .475                       | 41,100                                  | .921                   | 21,200                                 |                   |                | 3          | T                      |
| PB-6                      | 19,895                | .455                       | 43,700                                  | .910                   | 21,900                                 |                   |                | 3          | L                      |
| PC-6                      | 20,250                | .459                       | 44,100                                  | .886                   | 22,900                                 |                   |                | 3          | L                      |
| PD-6                      | 21,610                | .474                       | 45,600                                  | .874                   | 24,700                                 |                   |                | 3          | L                      |
| 10-inch stiffener spacing |                       |                            |   |                        |  |                   |                |            |                        |
| PA-8                      | 19,770                | .472                       | 41,900                                  | 1.008                  | 19,600                                 |                   |                | 3          | L,T                    |
| PB-8                      | 19,720                | .458                       | 43,000                                  | 1.001                  | 19,700                                 |                   |                | 3          | L                      |
| PC-8                      | 21,510                | .476                       | 45,200                                  | .990                   | 21,700                                 |                   |                | 3          | L                      |
| PD-8                      | 22,020                | .475                       | 46,400                                  | 1.021                  | 21,600                                 |                   |                | 3          | L                      |

<sup>a</sup>Notation for types of failure:

L, local buckling

T, torsional

Where two types of failure were observed in the same test, the one which seemed to the observers to be the primary type is listed first.

TABLE 6.- AVERAGE SHORTENING OF 24-INCH PANELS UNDER VARIOUS LOADS.

| Panel                     | Shortening in inches/10,000 under load P of |                |                |                  |                |                |                | Sub-critical load <sup>a</sup> | Sub-critical load <sup>a</sup> |
|---------------------------|---|----------------|----------------|------------------|----------------|----------------|----------------|--------------------------------|--------------------------------|
|                           | 5,000<br>(1b)                               | 10,000<br>(1b) | 12,000<br>(1b) | 14,000<br>(1b)   | 15,000<br>(1b) | 16,000<br>(1b) | 18,000<br>(1b) |                                |                                |
| 4-inch stiffener spacing  |   |                |                |                  |                |                |                |                                |                                |
| PA -9                     | 201   | 401            | 488            | 584              | 641            | --             | --             | 721                            | 15,830                         |
| PA-10                     | 212   | 423            | 508            | 596              | 658            | --             | --             | 695                            | 15,415                         |
| PB -9                     | 205   | 411            | 496            | 589              | 640            | 702            | --             | 813                            | 16,990                         |
| PB-10                     | 213   | 427            | 515            | 612              | 661            | 715            | --             | 815                            | 16,730                         |
| PC -9                     | 206   | 411            | 494            | 586              | 635            | 686            | 806            | 1044                           | 20,425                         |
| PC-10                     | 210   | 422            | 510            | 604              | 655            | 710            | 835            | 1146                           | 20,450                         |
| PD -9                     | 192   | 389            | 474            | 561              | 606            | 655            | 784            | 805                            | 18,140                         |
| 6-inch stiffener spacing  |   |                |                |                  |                |                |                |                                |                                |
| PA-11                     | 201   | 400            | 483            | 583              | --             | --             | --             | 585                            | 14,040                         |
| PA-12                     | 202   | 404            | 485            | 575              | 633            | --             | --             | 715                            | 15,600                         |
| PB-11                     | 222   | 404            | 489            | 584              | 635            | 705            | --             | 712                            | 16,215                         |
| PB-12                     | 190   | 394            | 480            | 570              | 615            | 665            | --             | 750                            | 17,100                         |
| PC-11                     | 201   | 399            | 484            | 572              | 619            | 669            | 786            | 922                            | 19,675                         |
| PC-12                     | 192   | 400            | 495            | 590              | 638            | 687            | 805            | 986                            | 20,070                         |
| PD-11                     | 196   | 389            | 467            | 556              | 599            | 648            | 793            | 798                            | 18,035                         |
| PD-12                     | 207   | 415            | 498            | 589              | 637            | 687            | --             | 812                            | 17,500                         |
| 8-inch stiffener spacing  |   |                |                |                  |                |                |                |                                |                                |
| PA-13                     | 190   | 380            | 458            | 544              | 590            | 647            | --             | 748                            | 16,835                         |
| PA-14                     | 195   | 399            | 505            | 684              | --             | --             | --             | 760                            | 14,500                         |
| PB-13                     | 193   | 383            | 466            | 554              | 601            | 653            | --             | 741                            | 17,355                         |
| PB-14                     | 210   | 415            | 496            | 585              | 631            | 685            | --             | 767                            | 17,220                         |
| PC-13                     | 203   | 403            | 486            | 575              | 620            | 670            | 783            | 978                            | 20,305                         |
| PC-14                     | 205   | 405            | 485            | 570              | 615            | 667            | 793            | 1090                           | 20,110                         |
| PD-13                     | 198   | 393            | 473            | 561              | 609            | 661            | --             | 763                            | 17,485                         |
| PD-14                     | 195   | 385            | 463            | 550              | 600            | 655            | 775            | 757                            | 17,705                         |
| 10-inch stiffener spacing |   |                |                |                  |                |                |                |                                |                                |
| PA-15                     | 189   | 376            | 454            | 543              | 601            | --             | --             | 678                            | 15,400                         |
| PA-16                     | 199   | 397            | 477            | 519 <sup>b</sup> | --             | --             | --             | 584                            | 13,785                         |
| PB-15                     | 191   | 380            | 459            | 545              | 591            | 639            | --             | 770                            | 17,355                         |
| PB-16                     | 190   | 390            | 470            | 560              | 610            | 660            | --             | 750                            | 17,450                         |
| PC-15                     | 199   | 397            | 481            | 567              | 611            | 663            | 782            | 953                            | 19,790                         |
| PC-16                     | 216   | 426            | 508            | 596              | 646            | 700            | 833            | 966                            | 19,310                         |
| PD-15                     | 192   | 385            | 468            | 553              | 599            | 648            | --             | 731                            | 17,200                         |
| PD-16                     | 186   | 380            | 465            | 555              | 602            | 660            | --             | 710                            | 17,060                         |

<sup>a</sup>Sub-critical load is last load before the ultimate.

<sup>b</sup>Reading for P = 13,000 lbs.

TABLE 7.-- AVERAGE SHORTENING OF 16-INCH PANELS UNDER VARIOUS LOADS

| Panel                     | Shortening in inches/10,000 under load P of |                |                |                |                |                |                |                                | Sub-critical load <sup>a</sup> |
|---------------------------|---|----------------|----------------|----------------|----------------|----------------|----------------|--------------------------------|--------------------------------|
|                           | 5,000<br>(lb)                               | 10,000<br>(lb) | 15,000<br>(lb) | 16,500<br>(lb) | 18,000<br>(lb) | 19,000<br>(lb) | 20,000<br>(lb) | Sub-critical load <sup>a</sup> |                                |
| 4-inch stiffener spacing  |   |                |                |                |                |                |                |                                |                                |
| PA-1                      | 138   | 277            | 431            | 485            | 553            | 625            | --             | 627                            | 19,015                         |
| PA-2                      | 145   | 287            | 438            | 491            | 566            | --             | --             | 650                            | 18,920                         |
| PB-1                      | 142   | 284            | 438            | 496            | 571            | --             | --             | 639                            | 18,875                         |
| PB-2                      | 140   | 280            | 432            | 480            | 555            | --             | --             | 655                            | 18,770                         |
| PC-1                      | 136   | 271            | 423            | 477            | 538            | 585            | 643            | 769                            | 21,335                         |
| PC-2                      | 138   | 275            | 425            | 478            | 535            | 580            | 638            | 750                            | 21,310                         |
| PD-1                      | 137   | 271            | 416            | 466            | 522            | 566            | 616            | 743                            | 21,405                         |
| PD-2                      | 130   | 262            | 410            | 460            | 515            | 555            | 600            | 710                            | 21,625                         |
| 6-inch stiffener spacing  |   |                |                |                |                |                |                |                                |                                |
| PA-4                      | 130   | 262            | 407            | 452            | 532            | --             | --             | 580                            | 18,360                         |
| PB-4                      | 125   | 256            | 400            | 450            | 508            | 550            | 604            | 705                            | 20,660                         |
| PC-4                      | 118   | 245            | 398            | 452            | 518            | 568            | 622            | 700                            | 20,960                         |
| PD-4                      | 128   | 258            | 395            | 441            | 498            | 540            | 585            | 690                            | 21,525                         |
| 8-inch stiffener spacing  |   |                |                |                |                |                |                |                                |                                |
| PA-6                      | 125   | 250            | 395            | 446            | 500            | 560            | --             | 620                            | 19,320                         |
| PB-6                      | 125   | 250            | 402            | 457            | 520            | 582            | --             | 622                            | 19,480                         |
| PC-6                      | 130   | 260            | 416            | 470            | 530            | 582            | --             | 690                            | 19,985                         |
| PD-6                      | 130   | 261            | 403            | 455            | 513            | 558            | 608            | 725                            | 21,280                         |
| 10-inch stiffener spacing |   |                |                |                |                |                |                |                                |                                |
| PA-8                      | 128   | 255            | 390            | 438            | 491            | 538            | --             | 575                            | 19,350                         |
| PB-8                      | 130   | 259            | 403            | 456            | 520            | 570            | --             | 590                            | 19,300                         |
| PC-8                      | 122   | 251            | 400            | 450            | 505            | 549            | 600            | 680                            | 21,100                         |
| PD-9                      | 125   | 250            | 385            | 430            | 480            | 518            | 560            | 638                            | 21,410                         |

<sup>a</sup>The sub-critical load is the last load at which readings were taken before the ultimate load.

TABLE 8.- LOADS AT INCIPIENT FAILURES OF TEST GROUP 3.

| Panel | Skin buckles |              | Stiffener waviness  |                     |                     | Stiffener twist     |                     |              |
|-------|--------------|--------------|---------------------|---------------------|---------------------|---------------------|---------------------|--------------|
|       | Stiff-ener 1 | Stiff-ener 3 | Stiff-ener 1        | Stiff-ener 2        | Stiff-ener 3        | Stiff-ener 1        | Stiff-ener 2        | Stiff-ener 3 |
| PA-2  | 12,015       | 12,015       | 18,700 <sup>a</sup> | 18,700 <sup>a</sup> | 18,700 <sup>a</sup> | 18,520              | 17,300 <sup>a</sup> | 18,520       |
| PA-4  | 15,000       | 15,000       | 16,380 <sup>a</sup> | 18,330 <sup>a</sup> | 16,445              | 18,330 <sup>a</sup> | -                   | 17,910       |
| PA-6  | 13,495       | 14,970       | 17,020 <sup>a</sup> | 19,340              | 19,160              | 18,320 <sup>a</sup> | 18,320 <sup>a</sup> | 19,340       |
| PA-8  | 17,010       | 12,010       | 17,795 <sup>a</sup> | 18,970 <sup>a</sup> | 17,795 <sup>a</sup> | 18,770              | -                   | 19,370       |
| PB-2  | 15,000       | 15,000       | 18,300 <sup>a</sup> | 18,300 <sup>a</sup> | 18,630              | 18,770 <sup>a</sup> | -                   | -            |
| PB-4  | 13,530       | 16,455       | -                   | 20,660              | 20,660              | 20,660              | -                   | -            |
| PB-6  | 13,520       | 18,670       | 19,180 <sup>a</sup> | 18,670              | 19,180 <sup>a</sup> | 19,180 <sup>a</sup> | -                   | -            |
| PB-8  | 14,995       | 18,020       | 19,100 <sup>a</sup> | 18,745              | 19,100 <sup>a</sup> | -                   | 15,680 <sup>a</sup> | -            |
| PC-2  | 16,470       | 10,530       | 20,680              | 19,040              | 19,040              | -                   | -                   | -            |
| PC-4  | 14,965       | 14,965       | 20,960              | 20,960              | 20,435 <sup>a</sup> | -                   | -                   | -            |
| PC-6  | 14,960       | 11,990       | 19,090              | 19,985              | 18,260 <sup>a</sup> | -                   | -                   | -            |
| PC-8  | 10,575       | 9,070        | 20,680 <sup>a</sup> | 20,680 <sup>a</sup> | 13,420 <sup>a</sup> | -                   | -                   | -            |
| PD-2  | 12,015       | 12,015       | 21,100              | 19,140              | 21,100              | -                   | -                   | -            |
| PD-4  | 10,520       | 10,520       | 21,525              | 21,525              | 22,225              | -                   | -                   | -            |
| PD-6  | 10,475       | 10,475       | 20,350 <sup>a</sup> | 21,280              | 14,980              | -                   | -                   | -            |
| PD-8  | 12,000       | 15,020       | 20,530              | 20,530              | -                   | -                   | -                   | -            |

<sup>a</sup>After maximum load had been passed.

TABLE 9.- PANEL ACTION OF TEST GROUP 3 IN FAILURE.

| Cycle | Phase<br>(a) | PA-2   | PA-4   | PA-6                | PA-8   | PB-2   | PB-4   | PB-6                | PB-8                |
|-------|--------------|--------|--------|---------------------|--------|--------|--------|---------------------|---------------------|
| 1     | A            | 19,200 | 18,160 | 19,520              | 19,770 | 19,000 | 21,100 | 19,895              | 19,720              |
|       | B            | -      | -      | -                   | -      | -      | -      | -                   | 19,720              |
|       | C            | 18,920 | 17,910 | 19,340              | 18,970 | 18,770 | 20,660 | 19,180              | 19,100              |
|       | D            | 18,860 | 17,890 | 19,280              | 18,890 | 18,700 | 20,600 | 19,120              | 19,035              |
| 2     | A            | 19,200 | 18,580 | 19,520              | 18,220 | 19,050 | 20,950 | 19,520              | 19,320              |
|       | B            | 18,700 | -      | -                   | -      | -      | 18,450 | -                   | -                   |
|       | C            | 18,300 | 18,360 | 19,070              | 18,780 | 18,300 | 17,310 | 18,140              | 18,920              |
|       | D            | 18,230 | 18,320 | 19,000              | 18,720 | 18,260 | 17,250 | 18,060              | 18,850              |
| 3     | A            | 18,600 | 18,800 | 19,320              | 19,020 | 18,475 | 18,000 | 18,420              | 19,120              |
|       | B            | -      | -      | 19,320 <sup>b</sup> | -      | -      | 15,200 | 18,280              | -                   |
|       | C            | 17,300 | 18,330 | 18,320              | 18,260 | 17,550 | 14,820 | 17,520              | 18,180              |
|       | D            | 17,250 | 18,300 | 18,260              | 18,110 | 17,500 | 14,685 | 17,410              | 18,120              |
| 4     | A            | 17,600 | 18,750 | 18,720              | 18,420 | 17,900 | -      | 17,670              | 18,360              |
|       | B            | 17,320 | -      | -                   | -      | -      | -      | 17,670 <sup>b</sup> | 18,360 <sup>b</sup> |
|       | C            | 17,000 | 17,500 | 17,020              | 17,795 | 16,800 | -      | 16,820              | 15,395              |
|       | D            | 16,950 | 17,400 | 16,920              | 17,855 | 16,740 | -      | 16,790              | 15,335              |
| 5     | A            | 17,300 | 17,800 | 17,320              | 18,020 | 17,100 | -      | 17,220              | 15,920              |
|       | B            | -      | -      | 16,850              | 17,410 | 16,610 | -      | -                   | 15,680              |
|       | C            | 16,180 | 16,380 | 15,820              | 16,950 | 16,000 | -      | 15,970              | 15,140              |
|       | D            | 16,110 | 16,300 | 15,770              | 16,840 | 15,970 | -      | 15,880              | -                   |
| 6     | A            | 16,400 | 17,000 | 16,120              | 17,320 | 16,300 | -      | 16,220              | -                   |
|       | B            | -      | 16,350 | -                   | -      | 15,750 | -      | -                   | -                   |
|       | C            | 15,150 | 15,500 | 15,220              | 14,420 | 15,300 | -      | 14,980              | -                   |
|       | D            | 15,100 | 15,380 | -                   | 14,020 | 15,250 | -      | 14,870              | -                   |
| 7     | A            | 15,500 | -      | -                   | -      | 15,600 | -      | -                   | -                   |
|       | B            | 14,800 | -      | -                   | -      | -      | -      | -                   | -                   |
|       | C            | 14,570 | -      | -                   | -      | 13,780 | -      | -                   | -                   |
|       | D            | 14,460 | -      | -                   | -      | 13,700 | -      | -                   | -                   |

<sup>a</sup>Phase A is maximum load of cycle.

Phase B is load just before failure.

Phase C is load just after failure.

Phase D is load after taking dial readings and just before starting next cycle.

<sup>b</sup>No decrease in load between phases A and B.

TABLE 9.- PANEL ACTION OF TEST GROUP 3 IN FAILURE- (CONTINUED.)

| Cycle | Phase | PC-2   | PC-4                | PC-6   | PC-8                | PD-2                | PD-4   | PD-6   | PD-8                |
|-------|-------|--------|---------------------|--------|---------------------|---------------------|--------|--------|---------------------|
| 1     | A     | 21,800 | 21,475              | 20,250 | 21,510              | 22,020              | 21,700 | 21,610 | 20,725              |
|       | B     | -      | -                   | -      | -                   | -                   | -      | -      | -                   |
|       | C     | 21,190 | 20,750              | 19,550 | 20,680              | 21,670              | 21,525 | 21,280 | 20,530              |
|       | D     | 21,150 | 20,700              | 19,490 | 20,620              | 21,550              | 21,450 | 21,240 | 20,480              |
| 2     | A     | 21,600 | 21,100              | 19,950 | 21,020              | 22,000              | 22,225 | 21,750 | 21,630              |
|       | B     | -      | -                   | -      | 19,380              | -                   | -      | -      | -                   |
|       | C     | 20,890 | 20,435              | 18,260 | 18,680              | 20,840              | 20,935 | 20,350 | 21,430              |
|       | D     | 20,790 | 20,385              | 18,210 | no rec              | 20,700              | 20,900 | 20,250 | 21,380              |
| 3     | A     | 20,900 | 20,900              | 18,700 | 19,020              | 21,100              | 21,400 | 20,500 | 22,020              |
|       | B     | -      | -                   | -      | 19,020 <sup>b</sup> | 19,600              | -      | -      | 21,895              |
|       | C     | 19,250 | 19,140              | 16,160 | 16,320              | 18,510              | 19,450 | 15,860 | 20,310              |
|       | D     | 19,190 | 19,060              | 15,980 | no rec              | 18,450              | 19,320 | 15,780 | 20,270              |
| 4     | A     | 19,600 | 19,400              | 16,300 | 16,920              | 18,830              | 19,700 |        | 20,760              |
|       | B     | 18,110 | 19,400 <sup>b</sup> | 16,180 | -                   | 18,830 <sup>b</sup> | 19,130 |        | 20,760 <sup>b</sup> |
|       | C     | 17,425 | 18,580              | 13,570 | 13,420              | 8,950               | 7,525  |        | 6,200               |
|       | D     | 17,350 | 18,530              |        |                     | 8,950               |        |        |                     |
| 5     | A     | 17,800 | 18,950              |        |                     |                     |        |        |                     |
|       | B     | 17,150 | 18,150              |        |                     |                     |        |        |                     |
|       | C     | 16,520 | 17,400              |        |                     |                     |        |        |                     |
|       | D     | 16,470 | 17,350              |        |                     |                     |        |        |                     |
| 6     | A     | 15,900 | 17,800              |        |                     |                     |        |        |                     |
|       | B     | -      | 17,800 <sup>b</sup> |        |                     |                     |        |        |                     |
|       | C     | 14,550 | 16,600              |        |                     |                     |        |        |                     |
|       | D     | 14,400 | 16,550              |        |                     |                     |        |        |                     |
| 7     | A     |        | 17,000              |        |                     |                     |        |        |                     |
|       | B     |        | -                   |        |                     |                     |        |        |                     |
|       | C     |        | 14,240              |        |                     |                     |        |        |                     |
|       | D     |        | 14,120              |        |                     |                     |        |        |                     |

<sup>b</sup>No decrease in load between phases A and B.

TABLE 10 - EXCERPTS FROM LOGS OF PANEL COMPRESSION TESTS

| Panel | Load<br>(lb) | Remarks   |
|-------|--------------|---|
| PA-2  | 18,300       | Stiffener 1 failing torsionally with secondary local buckling. Same action, but not so pronounced in stiffener 3. Stiffener 2 shows local buckling with secondary twist.                                    |
|       | 17,300       | All deformations much increased and deformation of stiffener 2 now appears primarily torsional and secondarily local buckling.  |
|       | 15,150       | Deformations have been increasing continuously.   |
| PA-4  | 17,910       | Slight noise due to sheet buckling. Stiffener 3 definitely twisting.  |
|       | 18,360       | Stiffener 3 twisting considerably. Stiffeners 1 and 2 show no distress.   |
|       | 18,330       | Stiffener 2 now has a buckle. Stiffener 1 shows no real distress, but is starting to twist.   |
|       | 17,500       | Same deformations more pronounced.  |
|       | 16,380       | Stiffener 1 now badly twisted. Both 1 and 3 are primarily twisting; whereas 2 exhibits primarily local buckling. Stiffener 1 also has a local buckle, but stiffener 3 has none.                             |
|       | 15,500       | Loud noise as buckles increase with sudden drop in load.  |
| PA-6  | 19,340       | No particular action at maximum load. Stiffener 2 shows signs of buckling of riveted flange. Stiffener shows combination of twisting and local buckling.  |
|       | 18,320       | Stiffener 3 failed with sharp noise. Stiffener 2 is buckled on riveted flange and to less extent on outer flange. It is also somewhat twisted. Stiffener 1 is twisted, but shows no serious local buckling. |
|       | 17,020       | Stiffener 1 now shows local buckling as well as considerable twist.   |
|       | 15,820       | Stiffener 2 failed noisily.   |
| PA-8  | 18,970       | Edge stiffeners are considerably twisted, but have not failed. Stiffener 2 has failed by local buckling of flanges near midheight.  |
|       | 17,795       | Edge stiffeners showing local buckling as well as twisting.   |
|       | 16,950       | Drop of load probably due to increased buckling of stiffener 2.   |
|       | 14,420       | Stiffener 1 is bearing against testing apparatus. The panel is badly deformed with edge stiffeners twisted and all three buckled locally. No rivets had failed.   |
| PB-2  | 18,300       | Stiffener 3 appears to have failed, primarily by local buckling.  |
|       | 17,550       | Stiffeners 1 and 2 appear to have failed primarily by local buckling.   |
| PB-4  | 17,720       | Slight noise from sheet buckling, no other change.  |
|       | 20,660       | Stiffener 1 twisting. Stiffener 2 has wavy outer flange. Stiffener 3 has buckle in outer flange.  |
|       | 17,310       | Loud noise with pronounced failure. Stiffener 1 twisted with secondary local buckle. Stiffeners 2 and 3 have fairly large buckles with secondary twisting. One rivet failed on stiffener 3.                 |
| PB-6  | 19,500       | (Before max. load.) Outer flange of stiffener 2 buckling locally and appears ready to fail.   |
|       | 19,180       | Buckle in flange of stiffener 2 slightly larger. Stiffener 3 appears to have failed by local buckling of both flanges near midheight. Stiffener 1 shows twist and incipient local buckling. No noise.       |
|       | 18,140       | Same failures more pronounced.  |
|       | 17,520       | Sharp noise due probably to change in buckle pattern of sheet.  |
|       | 16,820       | Sharp noise with intensification of stiffener buckles.  |

TABLE 10.- EXCERPTS FROM LOGS OF PANEL COMPRESSION TESTS (Contd.)

| Panel | Load<br>(lb) | Remarks  |
|-------|--------------|--|
| PB-8  | 19,100       | Noise at failure not loud. Definite local buckling of outer flange of stiffener 1 and incipient failures of outer flanges of stiffeners 2 and 3.   |
|       | 15,395       | Two noises heard before load reading could be taken. Bad local buckling of stiffener 1 and moderate failure of stiffener 2. Stiffener 3 shows distress but is in fairly good shape. Rotation pointer knocked off stiffener 1 in the failure of that stiffener. |
|       | 15,140       | Stiffener 2 rotated until pointer struck test apparatus. Stiffener 2 also badly buckled, but stiffener 3, although buckled locally, is still holding considerable load.  |
| PC-2  | 21,800       | Buckle forming in stiffener 3.   |
|       | 20,890       | Stiffener 3 appears to have failed by local buckling.  |
|       | 17,425       | Stiffeners 1 and 2 appear to have failed by local buckling. A rivet has failed in stiffener 3.   |
| PC-4  | 20,750       | Stiffener 1 appears to have failed by local buckling with secondary twist.   |
|       | 18,580       | Stiffeners 2 and 3 show considerable distress, but have not completely failed.   |
|       | 17,400       | Stiffener 2 has failed by local buckling.  |
|       | 16,600       | Stiffener 3 has failed by local buckling with secondary twist.   |
| PC-6  | 19,985       | (Before max. load.) Three waves in outer flange of stiffener 1, one on flange of stiffener 2, no definite buckling of stiffener 3.   |
|       | 19,550       | Failure of outer flange of stiffener 1.  |
|       | 18,260       | Bad bulges in outer flanges of stiffeners 1 and 2. Smaller bulge on flange of stiffener 3.   |
|       | 16,160       | All stiffeners show large buckles.   |
|       | 13,570       | Loud noise accompanied failure. Principal failure that of stiffener 1.   |
| PC-8  | 20,680       | Local buckles in both flanges of stiffeners 1 and 2. None on stiffener 3.  |
|       | 18,680       | Bad local buckling of stiffener 1, moderate buckling of stiffener 2, none on 3.  |
|       | 16,320       | More failure of stiffener 1, but stiffener 3 still holds.  |
|       | 13,420       | Stiffener 3 buckled near upper end. No sudden failure of this stiffener during the test.   |
| PD-2  | 21,670       | Stiffener 3 appears to have failed by local buckling.  |
|       | 20,840       | Stiffener 2 appears to have failed by local buckling.  |
|       | 18,510       | Stiffener 1 appears to have failed by local buckling.  |
|       | 8,950        | The panel failed with a loud noise and suddenly greatly increased deformation. The load drop was from 18,830 to 8,950.   |
| PD-4  | 19,450       | Stiffeners 1 and 2 appear to have failed by local buckling.  |
|       | 7,525        | When the load was 19,130, the panel failed completely with a loud noise. After this failure stiffener 3, although much twisted, appeared in relatively fair shape, but stiffeners 1 and 2 were badly buckled.  |
| PD-6  | 20,350       | Buckle in stiffener 2 fairly large. Stiffener 1 showing waviness. Buckles in stiffener 3 considerably increased in size.   |
|       | 15,860       | All three stiffeners are buckled near each end and equilibrium load is decreasing as strain increases. At no time in this test did anything give way with a noise.   |
| PD-8  | 20,310       | Platen dial no. 1 suddenly dropped back from 0.057 to 0.053. Stiffener 1 suddenly buckled, followed shortly by stiffener 2. Stiffener 3 showed no distress.  |
|       | 6,200        | When the load was 20,760, stiffeners 1 and 2 failed with a loud noise, but stiffener 3 showed no distress. The load dropped to 6,200.  |

TABLE 11.- PANEL ACTION OF TEST GROUP 2 IN FAILURE.

| Panel | Ulti-<br>mate<br>load<br>(lb) | Load at<br>first<br>failure<br>(lb) | Load<br>after<br>failure<br>(lb) | Ratio | Stiffener<br>that<br>failed <sup>a</sup> | Load at<br>second<br>failure<br>(lb) | Load<br>after<br>failure<br>(lb) | Stiffener<br>that<br>failed <sup>a</sup> | Load at<br>third<br>failure<br>(lb) | Load<br>after<br>failure<br>(lb) | Stiffener<br>that<br>failed |
|-------|-------------------------------|-------------------------------------|----------------------------------|-------|--|--------------------------------------|----------------------------------|--|-------------------------------------|----------------------------------|-----------------------------|
| PA-10 | 16,000                        | 16,000                              | 14,885                           | 0.93  | 3T                                       | 15,250                               | 15,000                           | 2T                                       | 15,350                              | 13,650                           | 1T                          |
| PA-12 | 15,900                        | 15,900                              | 15,850 <sup>b</sup>              | .98   | 3T                                       | 15,850                               | 15,640                           | 1T                                       | 15,000                              | 12,900                           | 2T                          |
| PA-14 | 15,100                        | 14,650                              | 14,500                           | .99   | 3T                                       | 15,100                               | ---                              | 2L                                       | ---                                 | ---                              | ---                         |
| PA-16 | 14,875                        | 14,875                              | 14,000                           | .94   | 2TL, 1T                                  | ---                                  | ---                              | ---                                      | ---                                 | ---                              | ---                         |
| PB-10 | 17,120                        | 16,715                              | 15,150                           | .90   | 3T                                       | ---                                  | ---                              | ---                                      | 12,725                              | 9,965                            | 1, 2                        |
| PB-12 | 17,500                        | 17,500                              | 16,975                           | .97   | 1T, 3T                                   | 16,500                               | 15,000                           | 3L, 2T                                   | ---                                 | ---                              | ---                         |
| PB-14 | 17,740                        | 17,610                              | 17,000                           | .96   | 3L                                       | 17,225                               | 16,730                           | 2LT                                      | 17,050                              | 16,625                           | 1LT                         |
| PB-16 | 18,280                        | 18,280                              | 17,700                           | .97   | 2T                                       | 18,200                               | 17,880                           | 1T                                       | 17,240                              | 16,150                           | 3LT                         |
| PC-10 | 20,450                        | 20,450                              | 13,430                           | .65   | 2L, 3LT                                  | ---                                  | ---                              | ---                                      | ---                                 | ---                              | ---                         |
| PC-12 | 20,450                        | 20,450                              | 17,370                           | .85   | 3L                                       | 17,250                               | ---                              | 2L                                       | ---                                 | ---                              | ---                         |
| PC-14 | 21,135                        | 21,135                              | 17,800                           | .84   | 3L, 2L                                   | 18,600                               | 15,000                           | 1L                                       | ---                                 | ---                              | ---                         |
| PC-16 | 19,950                        | 19,950                              | 19,225                           | .96   | 2L, 3L                                   | 19,700                               | ---                              | 2L, 3L                                   | ---                                 | ---                              | ---                         |
| PD-12 | 17,985                        | 17,985                              | 16,600                           | .92   | 3L, 2L                                   | ---                                  | 13,280                           | 1L                                       | ---                                 | ---                              | ---                         |
| PD-14 | 17,700                        | 15,500                              | 14,000 <sup>b</sup>              | .91   | 2L                                       | 14,000                               | ---                              | 1L, 3L                                   | ---                                 | ---                              | ---                         |
| PD-16 | 17,600                        | 17,600                              | 7,770 <sup>c</sup>               | .44   | 1T, 3T, 2L                               | ---                                  | ---                              | ---                                      | ---                                 | ---                              | ---                         |

<sup>a</sup>L indicates local and T torsional failure.<sup>b</sup>Reading not definite.<sup>c</sup>Violent failure.

TABLE 12.- POINTER ROTATIONS FOR 24-INCH PANELS

[Measured in radians/1,000]

| Panel | Sub-critical load<br>(lb) | Stiffener 1   |                |                   | Stiffener 2   |                |                   | Stiffener 3   |                |                   |
|-------|---------------------------|---------------|----------------|-------------------|---------------|----------------|-------------------|---------------|----------------|-------------------|
|       |                           | 8,000<br>(lb) | 12,000<br>(lb) | Sub-critical load | 8,000<br>(lb) | 12,000<br>(lb) | Sub-critical load | 8,000<br>(lb) | 12,000<br>(lb) | Sub-critical load |
| PA -9 | 15,830                    | -             | -              | -                 | 0             | +2             | +5                | -             | -              | -                 |
| PA-10 | 15,415                    | -11           | -26            | -129              | 0             | -4             | -5                | +1            | +11            | +80               |
| PB -9 | 16,990                    | -             | -              | -                 | +3            | +6             | -4                | -             | -              | -                 |
| PB-10 | 16,730                    | -6            | -22            | -141 <sup>a</sup> | -1            | -4             | -103              | +4            | +15            | +218              |
| PC -9 | 20,425                    | -             | -              | -                 | +1            | -1             | -23 <sup>b</sup>  | -             | -              | -                 |
| PC-10 | 20,450                    | -5            | -15            | -51 <sup>b</sup>  | 0             | 0              | -7 <sup>b</sup>   | 0             | +1             | +25 <sup>b</sup>  |
| PD -9 | 18,140                    | -             | -              | -                 | +3            | +5             | +35               | -             | -              | -                 |
| PA-11 | 14,550                    | -10           | -30            | -209              | -4            | -3             | +14               | +10           | +32            | +400              |
| PA-12 | 15,600                    | -5            | -14            | -172              | +7            | +16            | +65               | +5            | +26            | +227              |
| PB-11 | 16,160                    | -10           | -29            | -145              | 0             | 0              | +6                | -14           | -22            | -165              |
| PB-12 | 17,100                    | -4            | -5             | -67               | -2            | -7             | -65               | +3            | +11            | +129              |
| PC-11 | 20,580                    | -5            | -16            | -141              | -4            | -9             | -64               | -1            | +2             | +90               |
| PC-12 | 20,070                    | -9            | -14            | -111              | +1            | -1             | -10               | +5            | +9             | +152              |
| PD-11 | 18,035                    | -7            | -7             | -6                | 0             | -2             | -16               | +14           | +23            | +49               |
| PD-12 | 17,500                    | -2            | +1             | -14               | -4            | -10            | -28               | +2            | +7             | +10               |
| PA-13 | 16,835                    | -11           | -24            | -226              | +3            | +4             | -4                | +9            | +23            | +185              |
| PA-14 | 14,500                    | -5            | -13            | -27               | -4            | +1             | +48               | +28           | +240           | +535              |
| PB-13 | 17,355                    | -7            | -16            | -122              | -4            | -6             | +11               | +1            | +8             | +78               |
| PB-14 | 17,220                    | 0             | -1             | -45               | +12           | +12            | +13               | +21           | +42            | +179              |
| PC-13 | 20,305                    | -2            | -10            | -97               | -1            | -4             | -36               | +3            | +9             | +125              |
| PC-14 | 20,110                    | -4            | -15            | -66               | -5            | -13            | -48               | -1            | +4             | +65               |
| PD-13 | 17,485                    | +9            | +15            | +34               | +6            | +8             | +22               | -12           | -24            | -86               |
| PD-14 | 17,705                    | -4            | -4             | -12               | -1            | -5             | -15               | -7            | -4             | 0                 |
| PA-15 | 15,400                    | -12           | -38            | -239              | -5            | -10            | -135              | -3            | +3             | +90               |
| PA-16 | 13,785                    | -7            | -28            | -51               | 0             | 0              | +6                | +7            | +31            | +216              |
| PB-15 | 17,215                    | -8            | -26            | -124              | -3            | -6             | -34               | -1            | -5             | -23               |
| PB-16 | 17,450                    | -2            | -8             | -42               | -5            | -13            | -61               | +5            | +7             | +54               |
| PC-15 | 19,860                    | 0             | -5             | -59               | -4            | -12            | -64               | +5            | +11            | +154              |
| PC-16 | 19,310                    | +3            | 0              | -55               | +3            | +9             | +48               | +3            | +13            | +78               |
| PD-15 | 17,250                    | +3            | +5             | +16               | +2            | +1             | +11               | -6            | -7             | -18               |
| PD-16 | 17,060                    | +32           | +55            | +258              | -6            | -15            | -37               | -8            | -10            | -14               |

<sup>a</sup> Under 16,715 pounds, pointer knocked off before next reading could be taken.

<sup>b</sup> Under 18,000 pounds, no readings were recorded for higher loads.

TABLE 13.- POINTER ROTATIONS FOR 16-INCH PANELS

[Measured in radians/1,000]

| Panel | Sub-critical load<br>(lb) | Stiffener 1    |                |                   | Stiffener 2    |                |                   | Stiffener 3    |                |                   |
|-------|---------------------------|----------------|----------------|-------------------|----------------|----------------|-------------------|----------------|----------------|-------------------|
|       |                           | 15,000<br>(lb) | 18,000<br>(lb) | Sub-critical load | 15,000<br>(lb) | 18,000<br>(lb) | Sub-critical load | 15,000<br>(lb) | 18,000<br>(lb) | Sub-critical load |
| PA-1  | 19,015                    | -              | -              | -                 | +2             | -3             | -20               | -              | -              | -                 |
| PA-2  | 18,920                    | -8             | -38            | -108              | -7             | -25            | -81               | +8             | +27            | +62               |
| PB-1  | 18,450                    | -              | -              | -                 | -6             | -17            | -26               | -              | -              | -                 |
| PB-2  | 18,770                    | -5             | -11            | -33               | +3             | +3             | +17               | +13            | +42            | +140              |
| PC-1  | 21,335                    | -              | -              | -                 | -5             | -12            | -37               | -              | -              | -                 |
| PC-2  | 21,310                    | -3             | -8             | -38               | -3             | -8             | -22               | +5             | +8             | +50               |
| PD-1  | 21,405                    | -              | -              | -                 | +5             | +10            | +31               | -              | -              | -                 |
| PD-2  | 21,625                    | -5             | -10            | -40               | 0              | 0              | -10               | +5             | +8             | +30               |
| PA-4  | 18,360                    | -12            | -22            | -28               | 0              | -10            | -16               | +28            | +120           | +206              |
| PB-4  | 20,660                    | -5             | -11            | -105              | 0              | 0              | +15               | +8             | +18            | +40               |
| PC-4  | 20,960                    | 0              | -2             | +17               | -6             | -10            | -18               | +5             | +9             | +14               |
| PD-4  | 21,525                    | +5             | +8             | +15               | 0              | 0              | 0                 | 0              | +3             | +12               |
| PA-6  | 19,320                    | -12            | -21            | -45               | -2             | +5             | +40               | +16            | +40            | +144              |
| PB-6  | 19,480                    | -12            | -23            | -50               | +15            | +34            | +75               | +13            | +25            | +52               |
| PC-6  | 19,985                    | -4             | -5             | -25               | 0              | 0              | +10               | 0              | 0              | -17               |
| PD-6  | 21,280                    | +8             | +10            | +20               | 0              | 0              | -4                | -14            | -23            | -40               |
| PA-8  | 19,350                    | -15            | -40            | -74               | 0              | 0              | +15               | 0              | -6             | -18               |
| PB-8  | 19,300                    | -5             | -5             | -12               | 0              | -5             | -21               | 0              | 0              | -30               |
| PC-8  | 21,100                    | -5             | -7             | -10               | 0              | 0              | +12               | 0              | 0              | -12               |
| PD-8  | 21,410                    | +9             | +11            | +18               | -4             | -8             | -13               | -3             | -4             | -7                |

TABLE 14.- ULTIMATE STIFFENER LOADS UNDER AXIAL COMPRESSION.

| Specimen         | Shape | Ultimate load<br>(lb) | Ultimate stress<br>(lb/sq in.) | Thickness, t<br>(in.) | I, minimum<br>(in. <sup>4</sup> ) | <sup>2</sup> EI/L <sup>2</sup><br>(lb) |
|------------------|-------|-----------------------|--------------------------------|-----------------------|-----------------------------------|--|
| 16 - inch Length |       |                       |                                |                       |                                   |  |
| B - 1            | Z     | 5,080                 | 32,400                         | 0.0642                | 0.00520                           | 2070                                   |
| C - 1            | S     | 5,900                 | 37,600                         | 0.0647                | 0.00622                           | 2480                                   |
| D - 1            | C     | 4,730                 | 30,000                         | 0.0649                | 0.01105                           | 4400                                   |
| 24 - inch Length |       |                       |                                |                       |                                   |  |
| B - 5            | Z     | 2,940                 | 19,000                         | 0.0635                | 0.00515                           | 910                                    |
| C - 5            | S     | 3,960                 | 24,300                         | 0.0641                | 0.00616                           | 1080                                   |
| D - 5            | C     | 3,240                 | 20,300                         | 0.0656                | 0.01118                           | 1970                                   |

Figure 1

NOMINAL SPECIMEN DIMENSIONS

Typical Panel

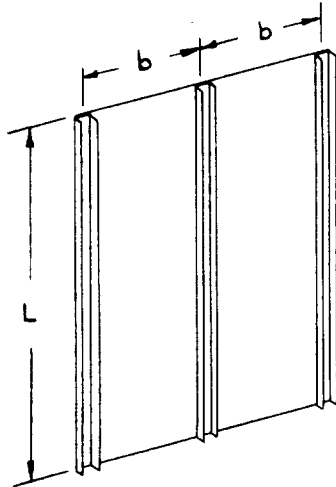

Material  
 Sheet - 24S-T  
 Stiffeners - 24S-RT

Sheet thickness - 0.025 in.  
 Stiffener thick.- 0.064 in.

Rivets - 3/32" d. brazier head  
 Al7S-T Al. Alloy  
 3/4 in. pitch

b = 4, 6, 8, and 10 in.  
 L = 16 and 24 in.

Typical Stiffeners

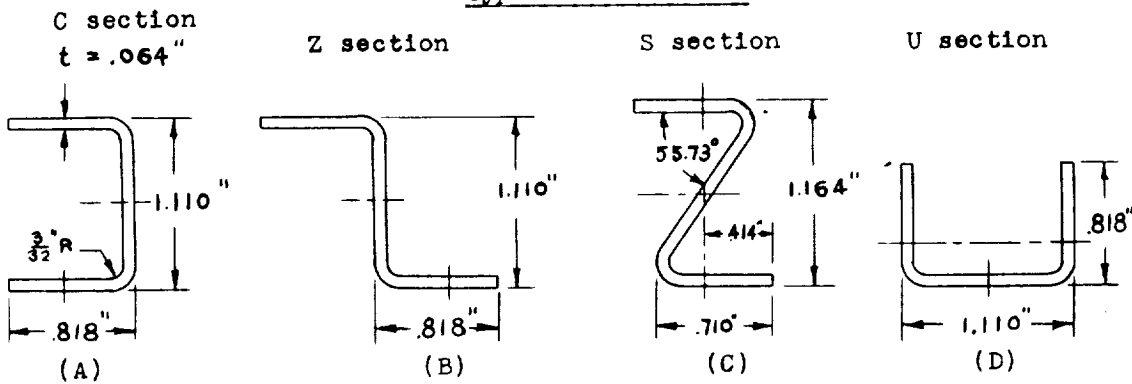

Stiffener Sections

|                                    | Section A, B, and C    | Section D              |
|------------------------------------|------------------------|------------------------|
| Developed length of center line, s | 2.52 in.               | 2.52 in.               |
| Thickness, t                       | .064 in.               | .064 in.               |
| Cross-section area, A              | .161 sq.in.            | .161 sq.in.            |
| Inside radius of bends, r          | 3/32 in.               | 3/32 in.               |
| Moment of inertia, I (about c.g.)  | .0316 in. <sup>4</sup> | .0109 in. <sup>4</sup> |

Note: Rivet center line is in the center of the flange flat except for stiffener C; for C the position of rivet center line is given above.



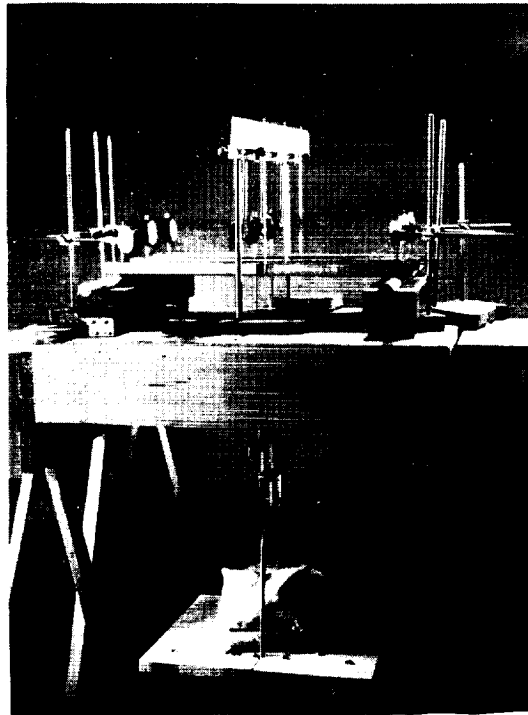

Figure 2.- Panel bending test, side view.

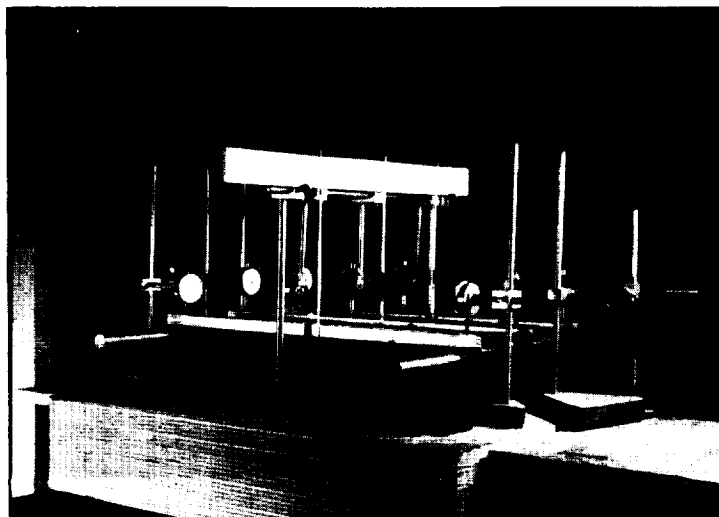

Figure 3.- Panel bending test, three-quarter view.



Figure 4

LOADING DEVICE FOR PANEL BENDING TESTS

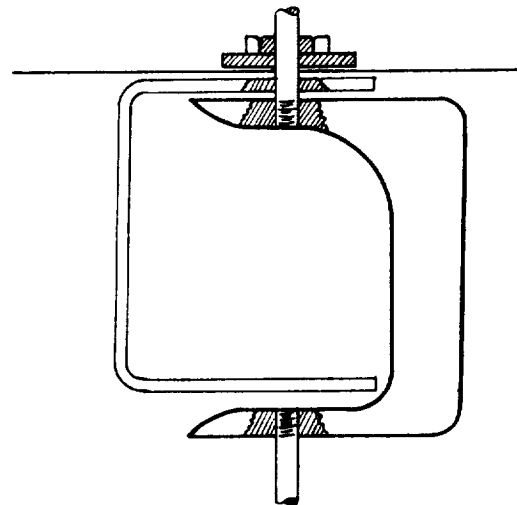
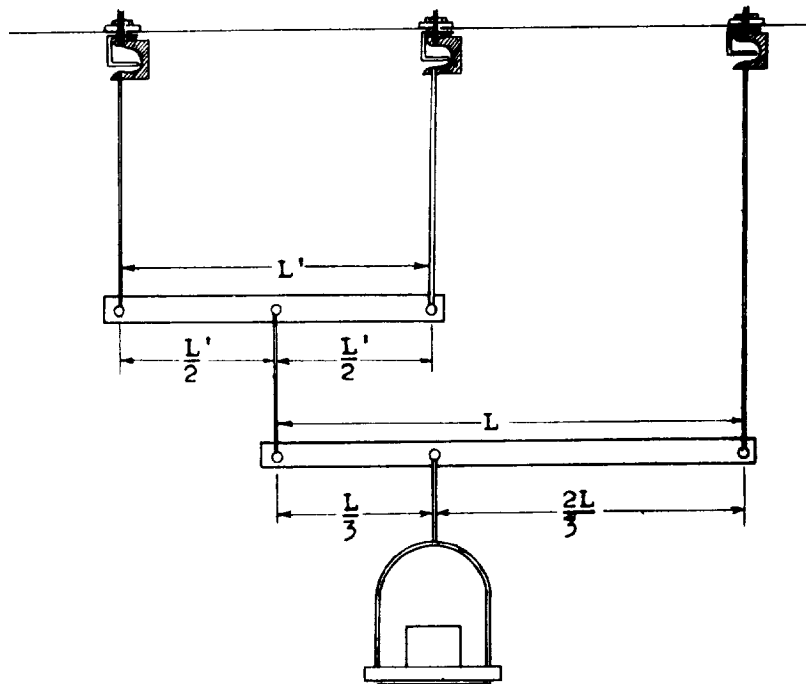

Figure 5

SKETCH OF OFF SET FITTING

Figures 4 and 5.



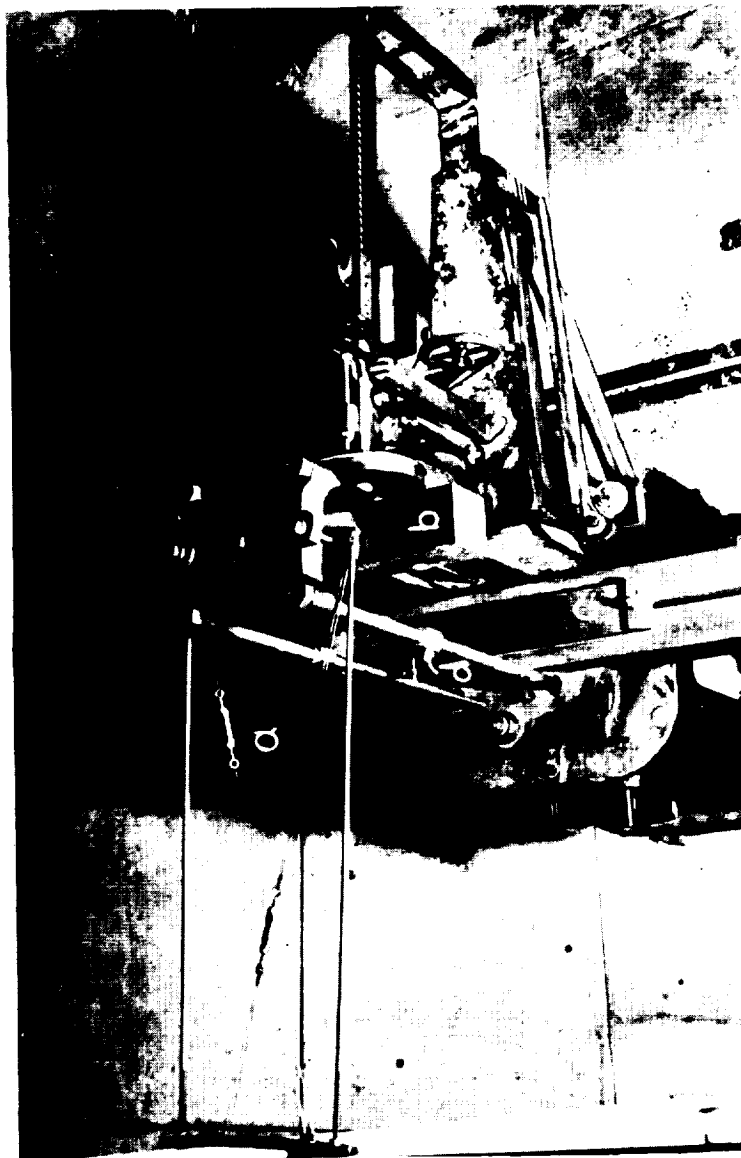

Figure 6.- Plan view of testing machine. (a) Bracing to stabilize upper platen. (b) Upper platen. (c) Lower platen. (d) Extension rods.



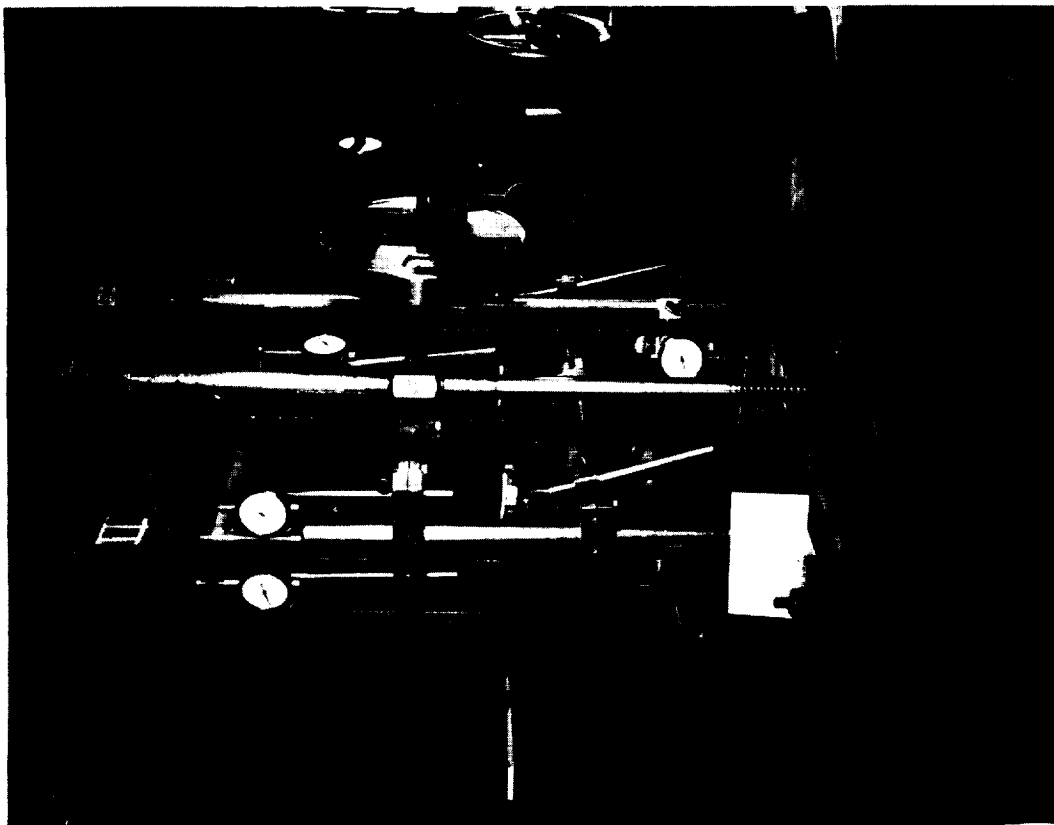

Figure 8.- Panel compression test,  
rear view.

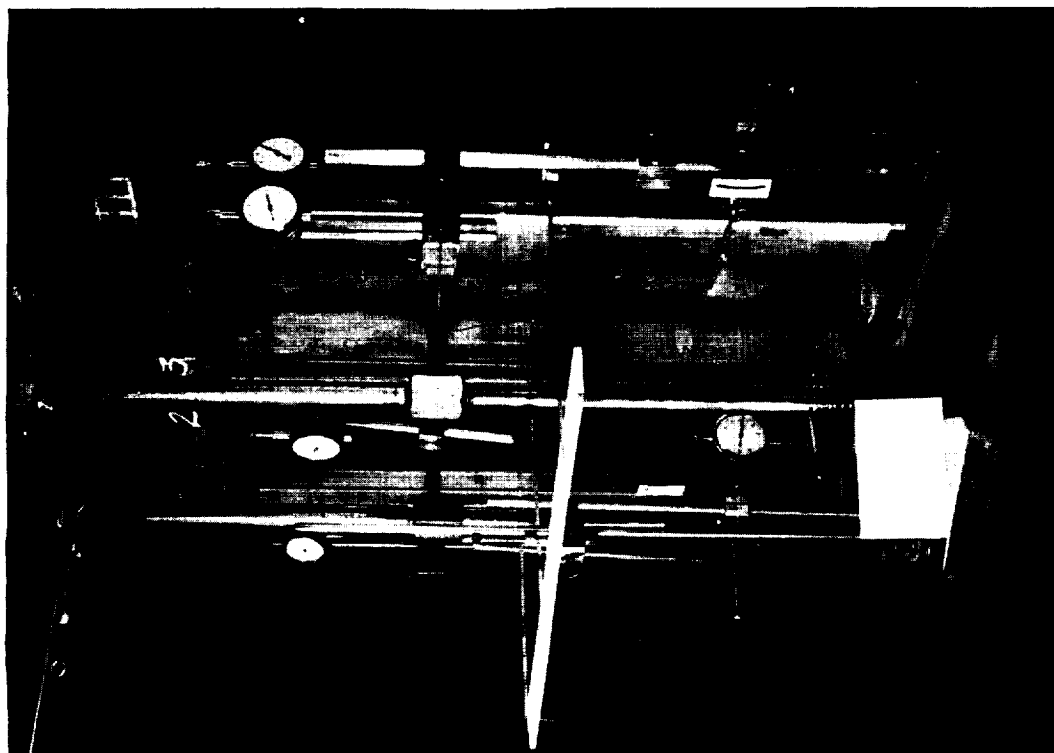

Figure 7.- Panel compression test,  
front view.



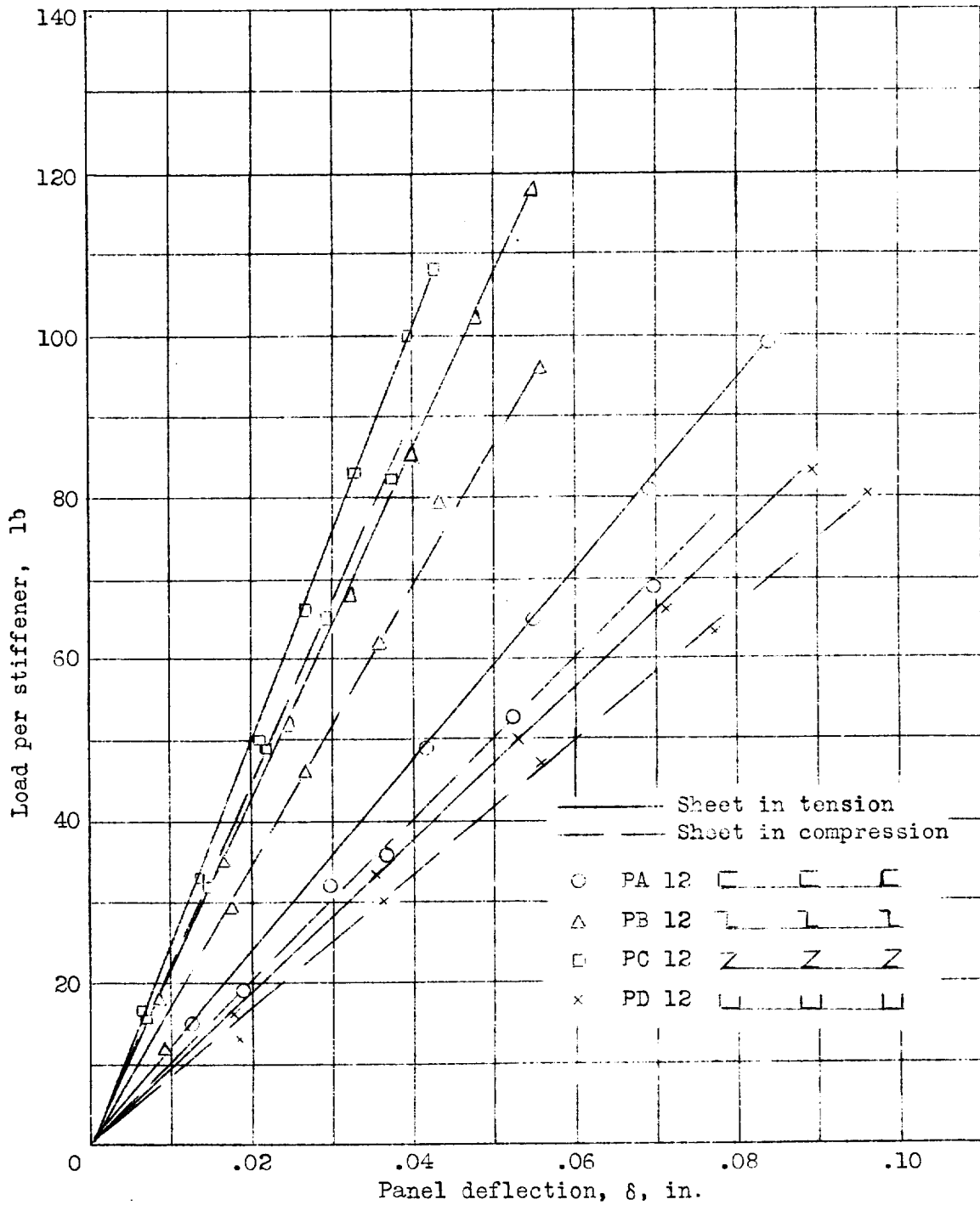
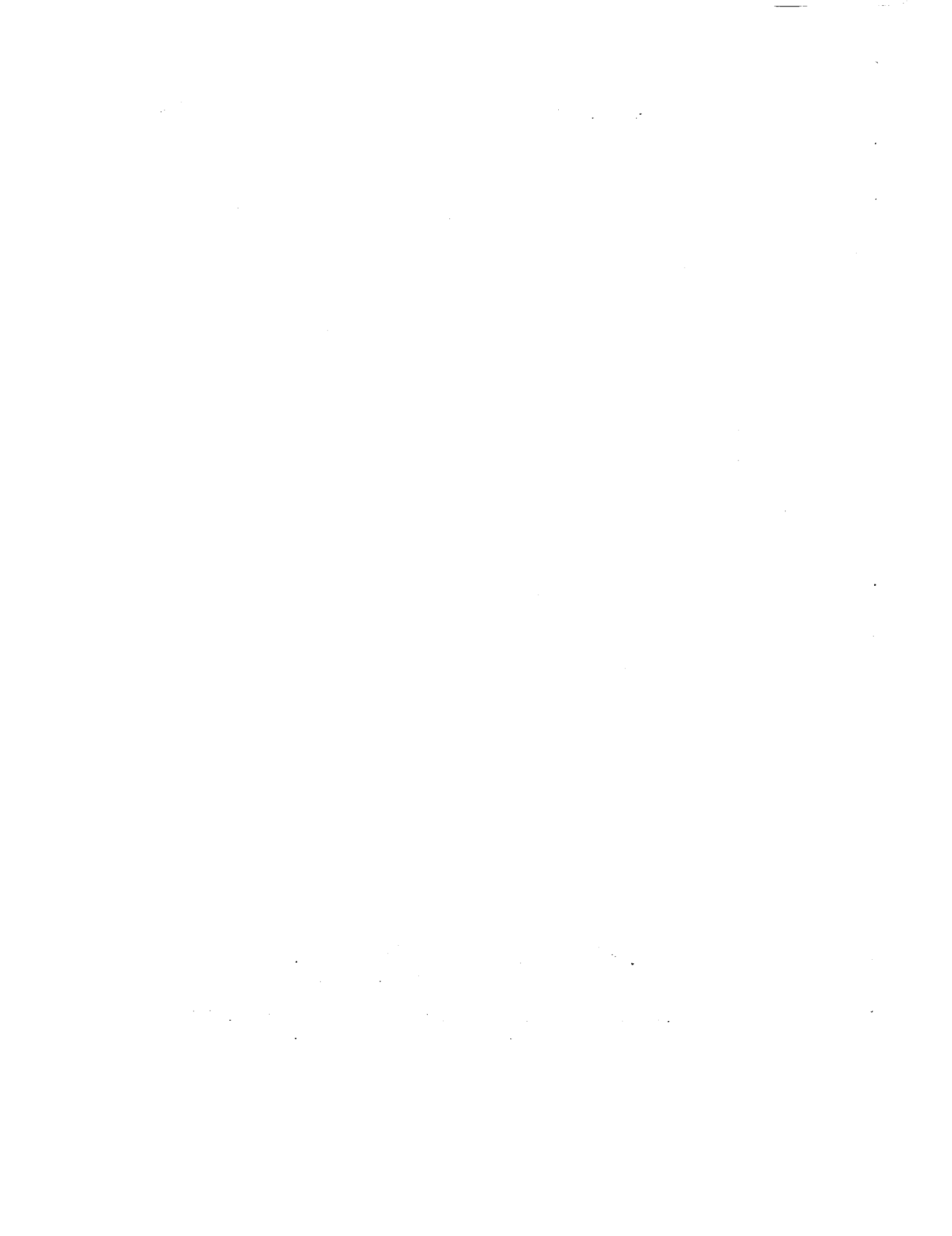

Figure 9.- Load deflection curves for panels in bending, 6-inch circle spacing, center stiffener only.



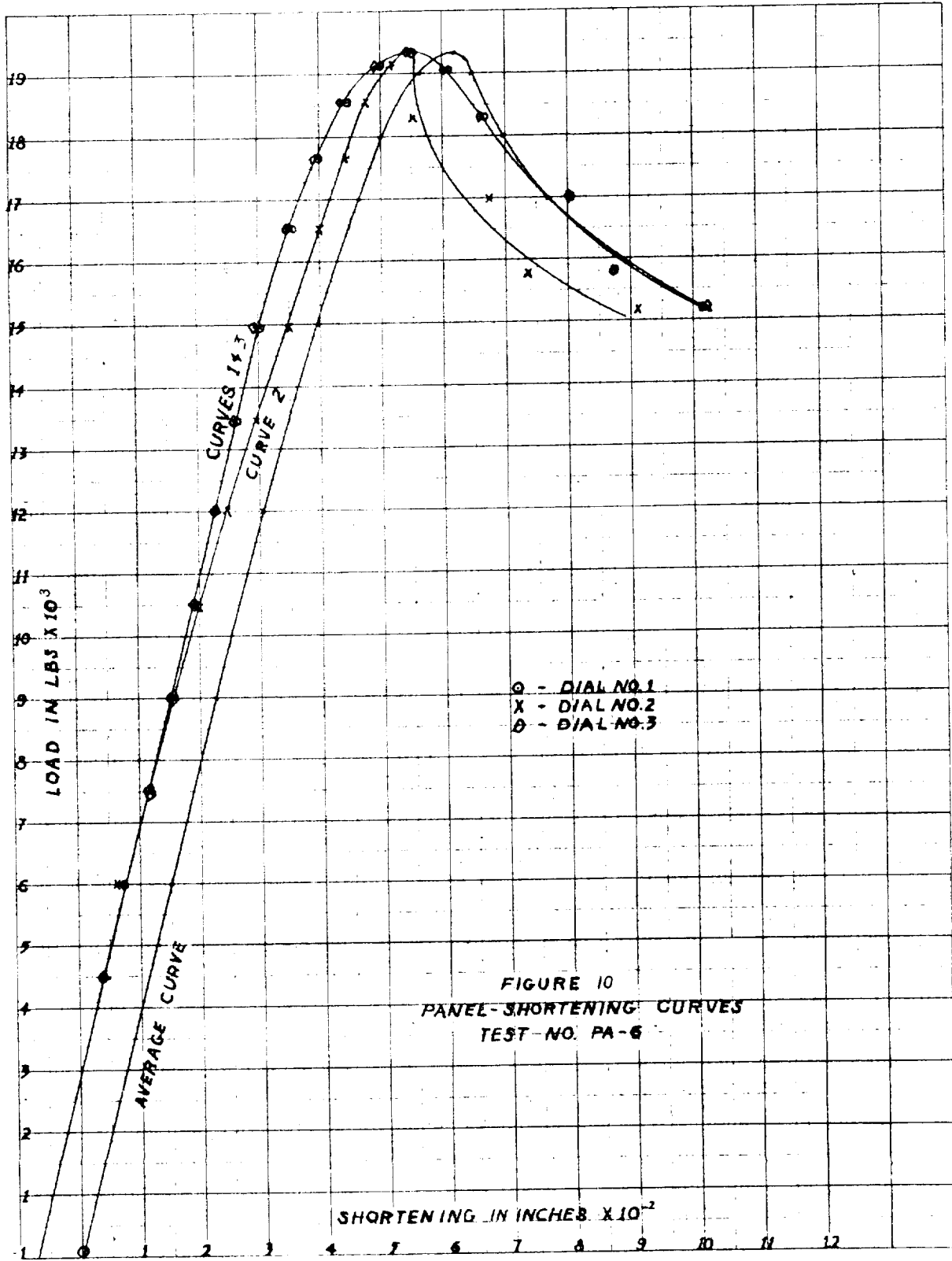
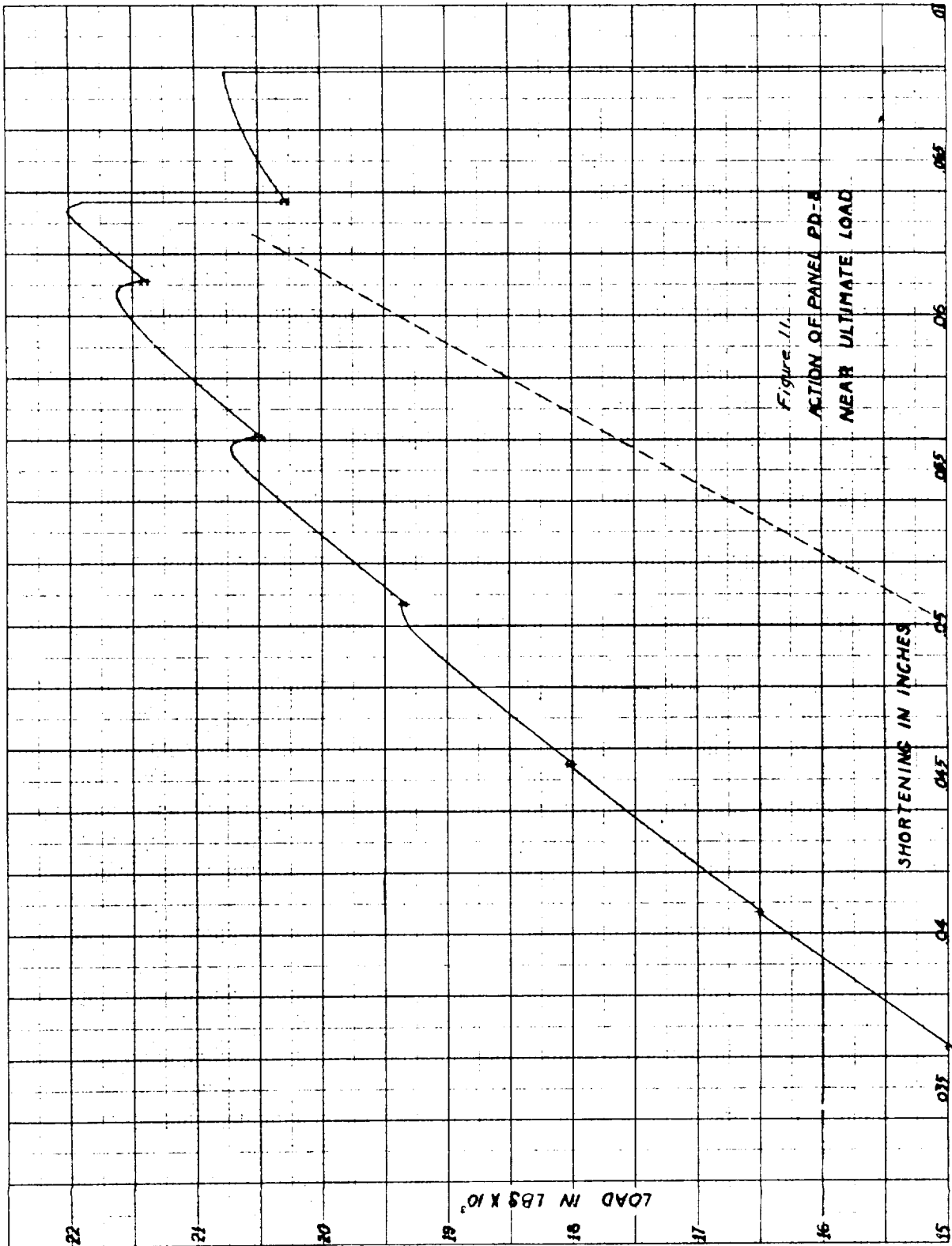
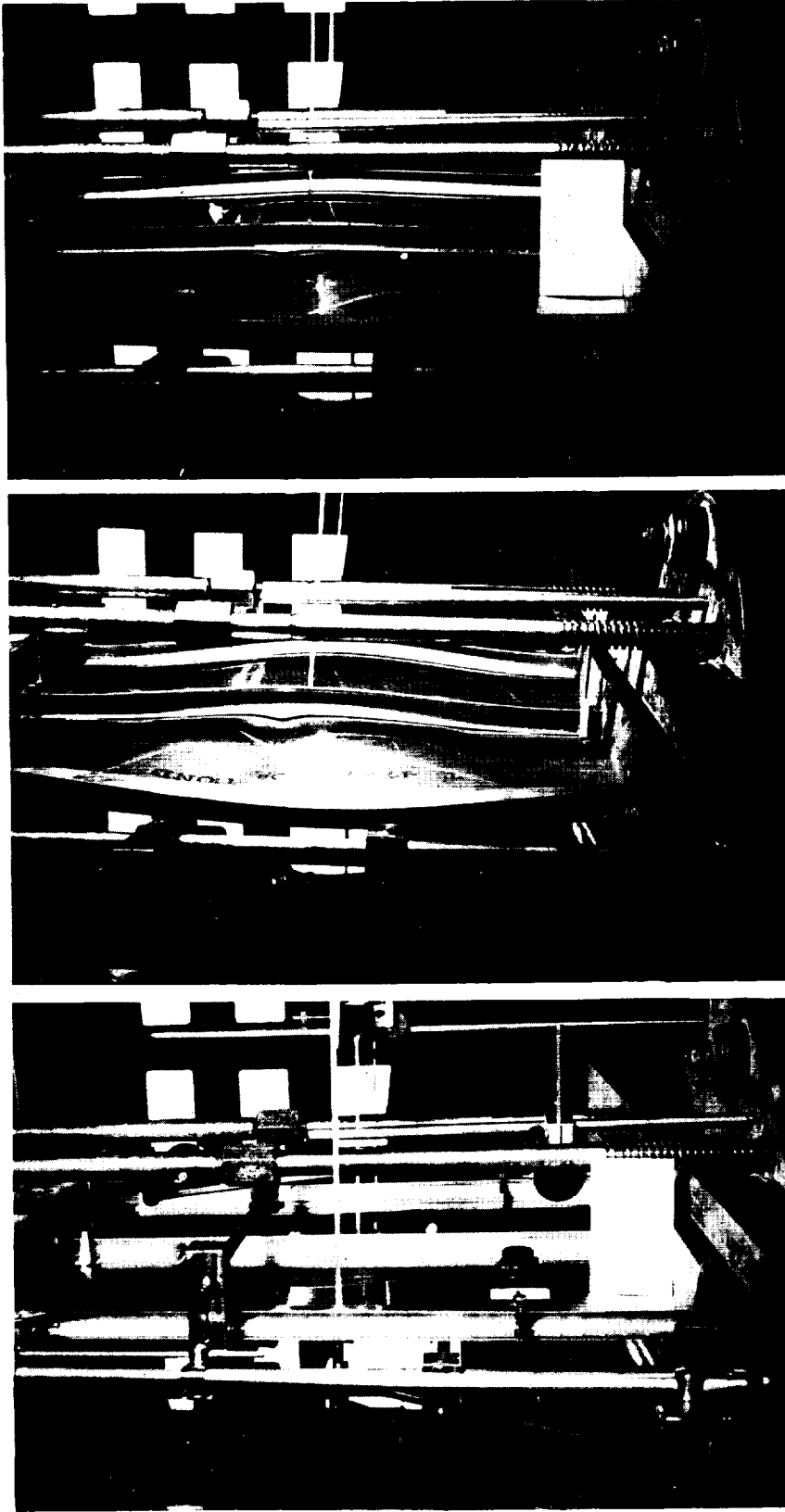

FIGURE 10  
PANEL-SHORTENING CURVES  
TEST-NO. PA-6









(a) Under initial load.

(b) Under maximum load.

(c) Under initial load as moving head of testing machine was raised.

Figure 12.- Sequence photographs panel PA-16.



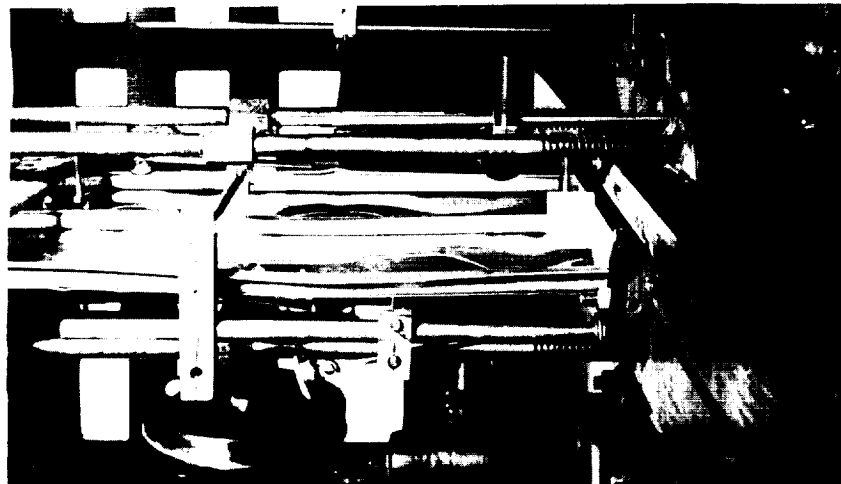

(a) Under initial load.



(b) Under maximum load.

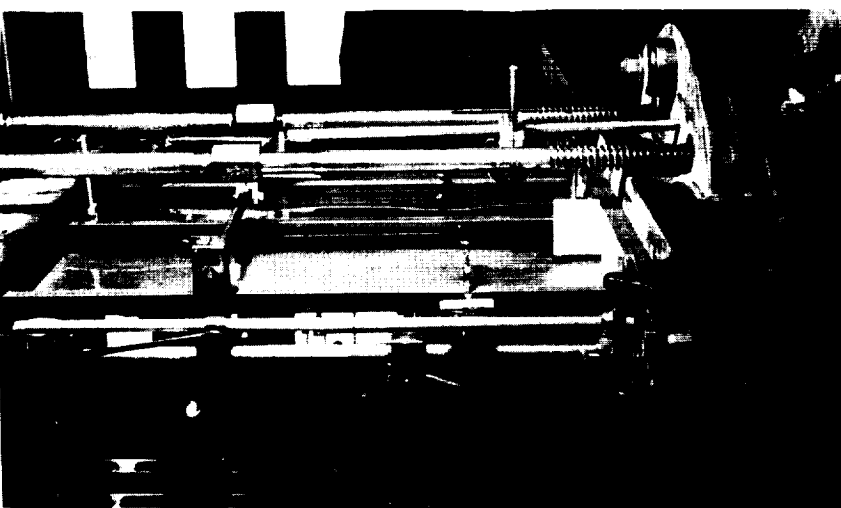

(c) Under initial load as moving head of testing machine was raised.

Figure 13.- Sequence photographs panel PB-16.



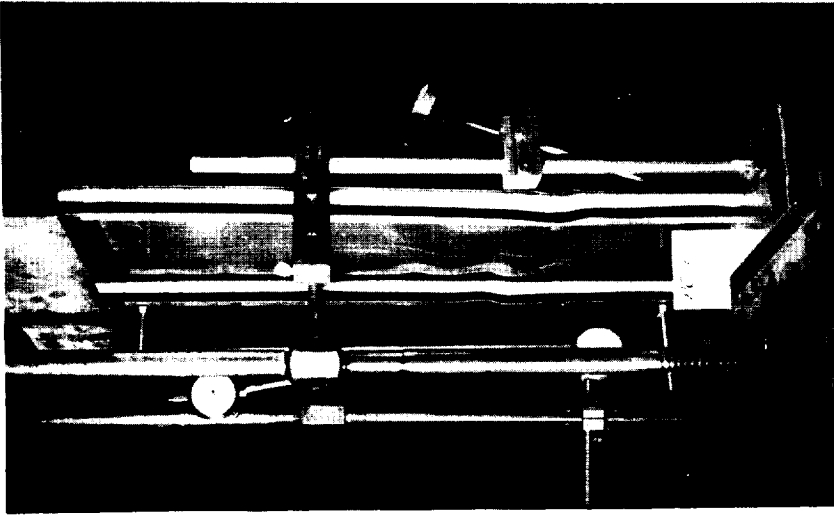

(c) Under initial load as moving head of testing machine was raised.

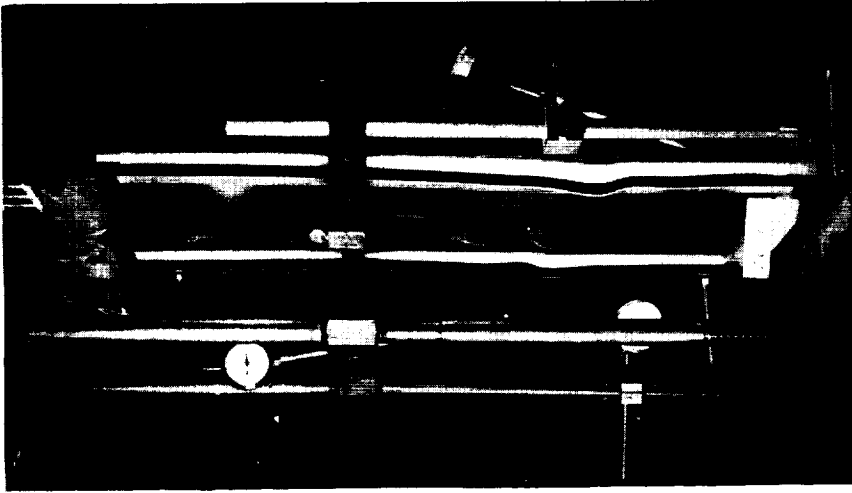

(b) Under maximum load



(a) Under initial load.

Figure 14.- Sequence photographs panel PC-16.



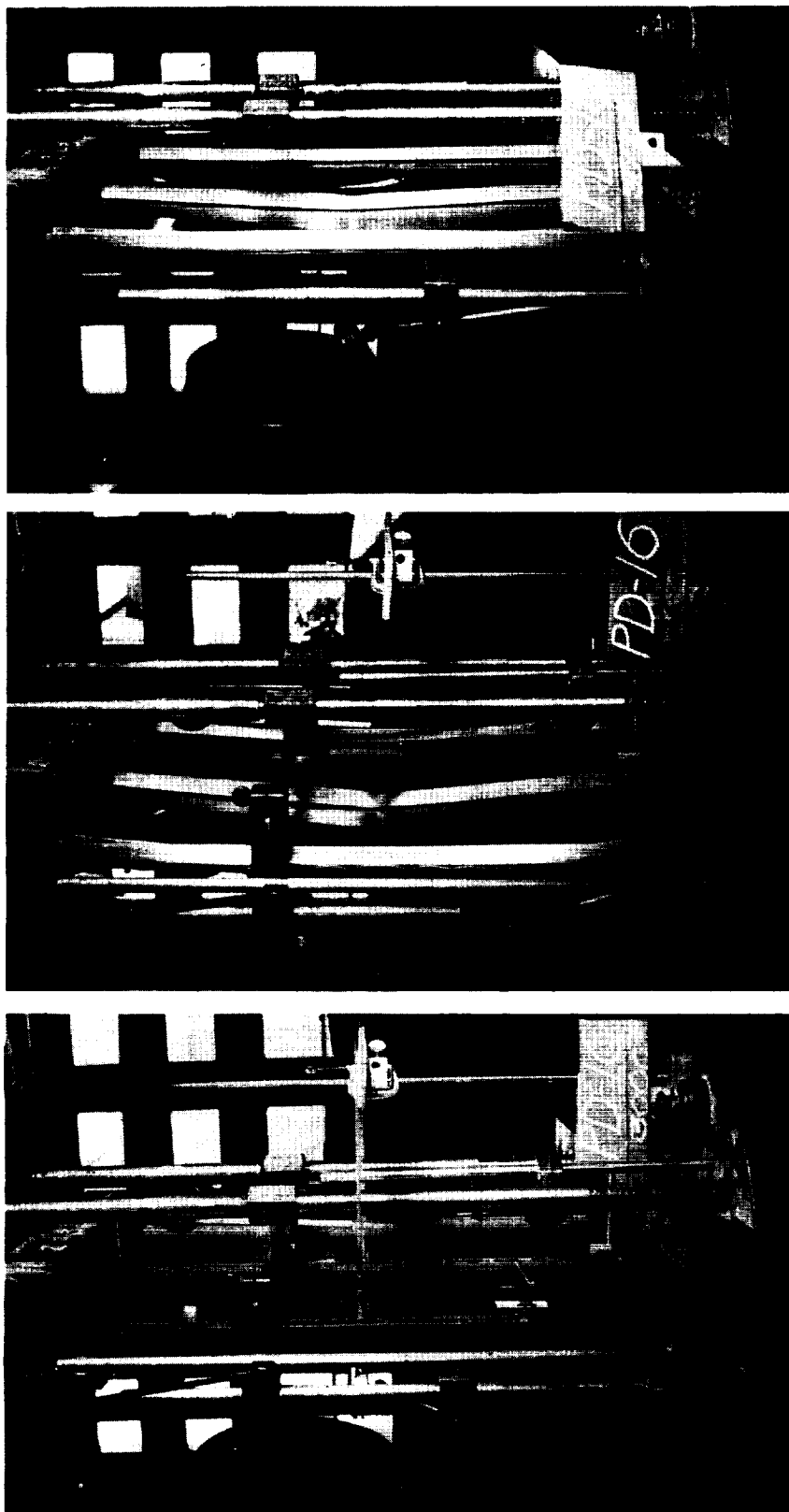

(a) Under initial load. (b) Under maximum load. (c) Under initial load as moving head of testing machine was raised.

Figure 15.- Sequence photographs, panel PD-16.



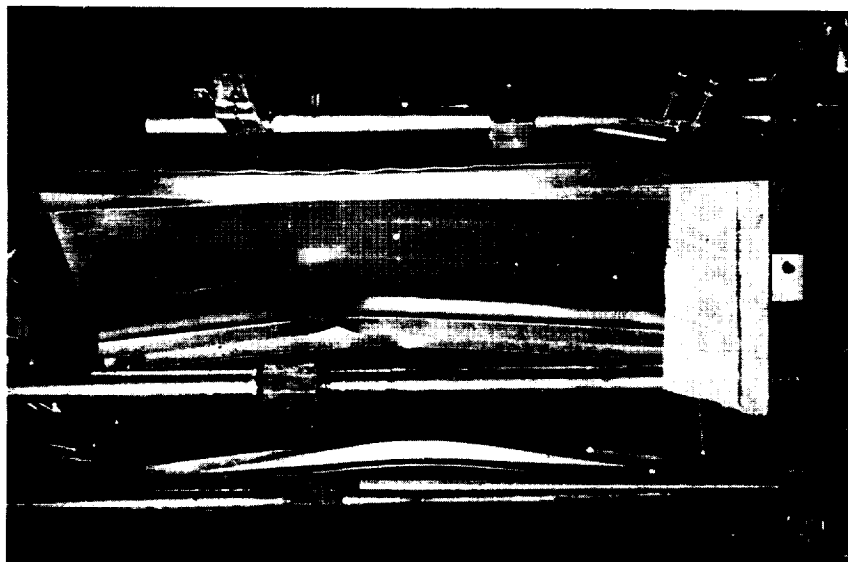

Figure 17.- Panel PD-16 under maximum load.



Figure 16.- Panel PD-16 under maximum load.



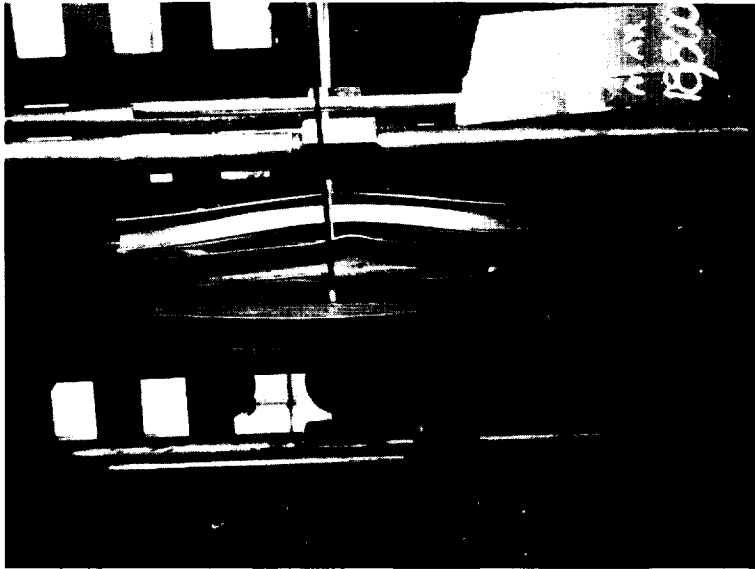

Figure 19.- Panel PA-4 under  
15,380 pounds  
after subjecting to 18,800  
pounds.

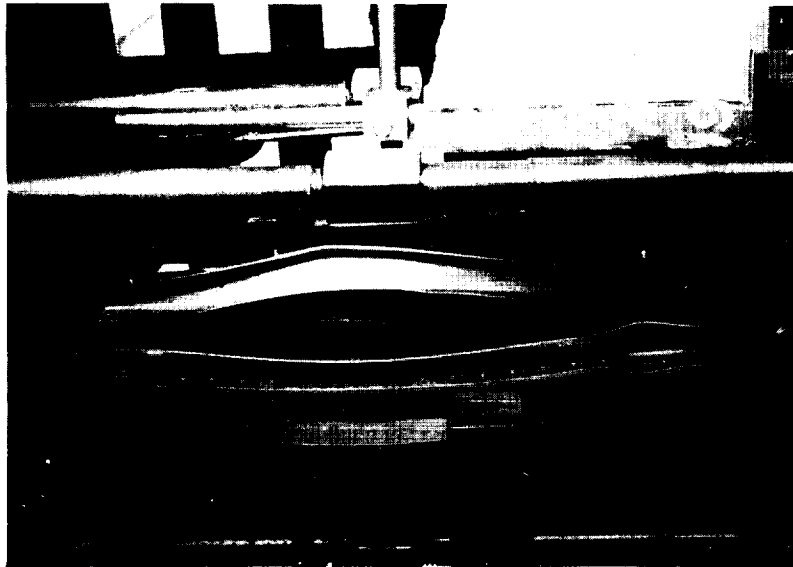

Figure 18.- Panel PA-2 under  
14,460 pounds  
after subjecting to 19,200  
pounds.



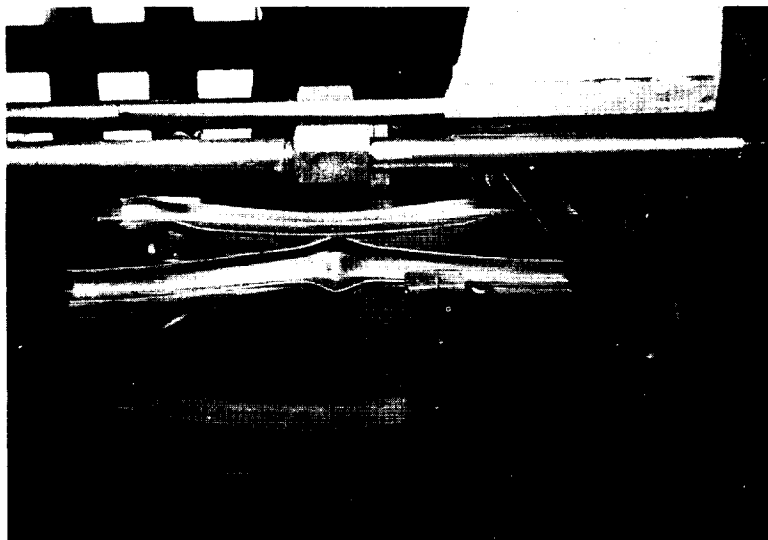

Figure 21.- Panel PA-8 under  
14,000 pounds  
after subjection to 19,750  
pounds.

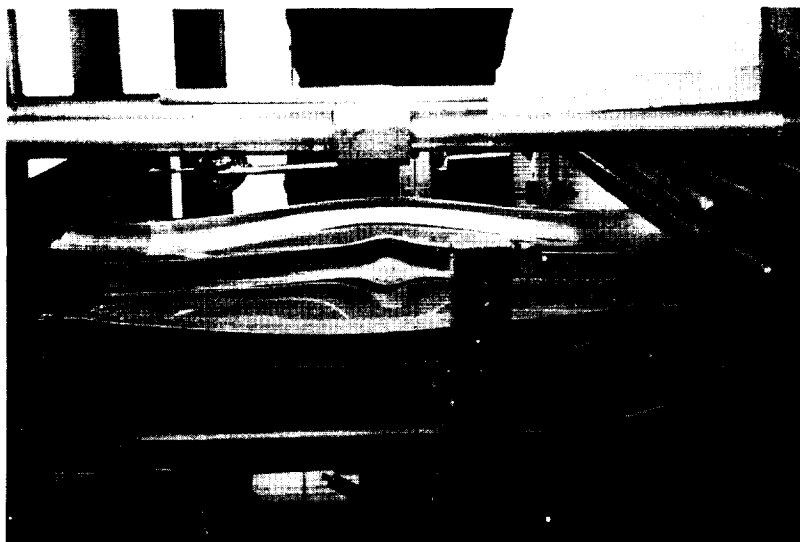

Figure 20.- Panel PA-6 under  
15,100 pounds  
after subjection to 19,500  
pounds.



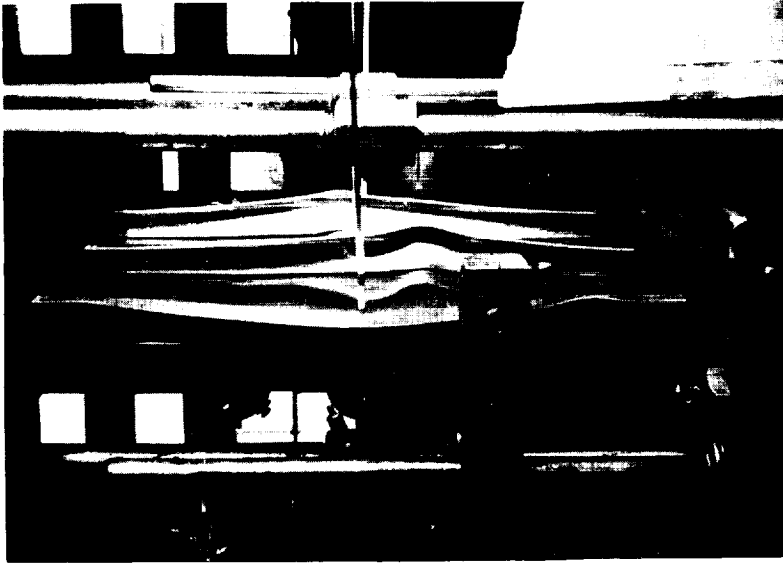

Figure 23.- Panel PB-4 under  
14,685 pounds  
after subjecting to 21,100  
pounds.

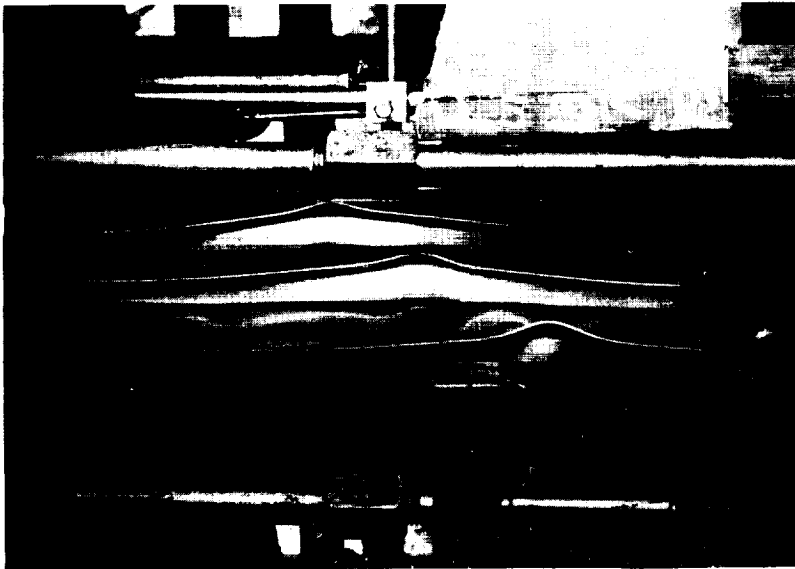

Figure 22.- Panel PB-4 under  
13,700 pounds  
after subjecting to 19,050  
pounds.



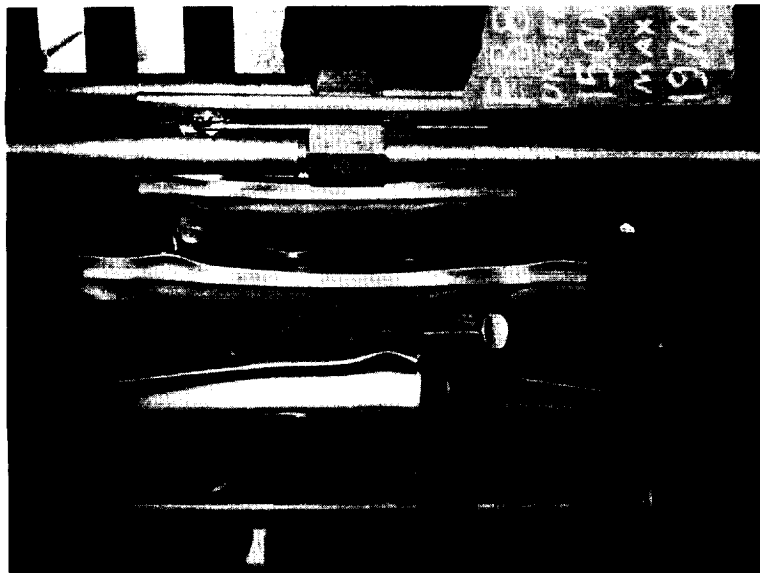

Figure 25. - Panel PB-8 under 15,000 pounds after subjecting to 19,700 pounds.

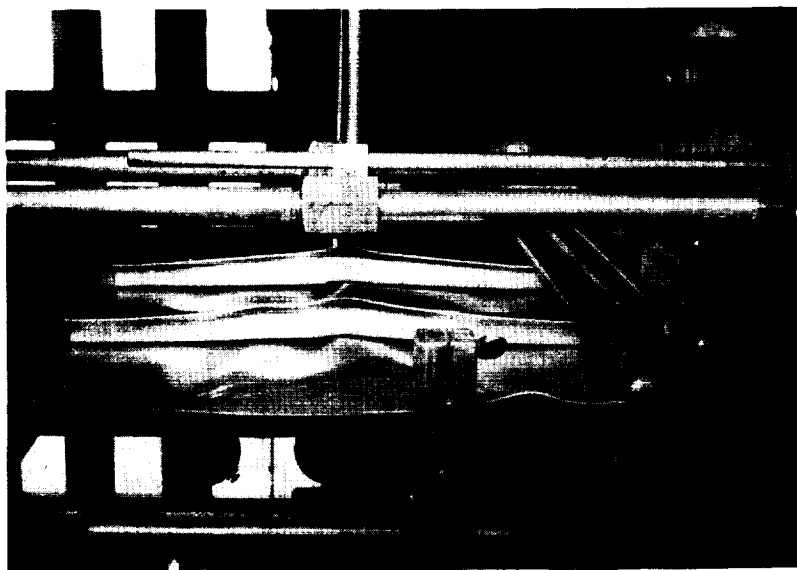

Figure 24. - Panel PB-6 under 14,850 pounds after subjecting to 19,875 pounds.



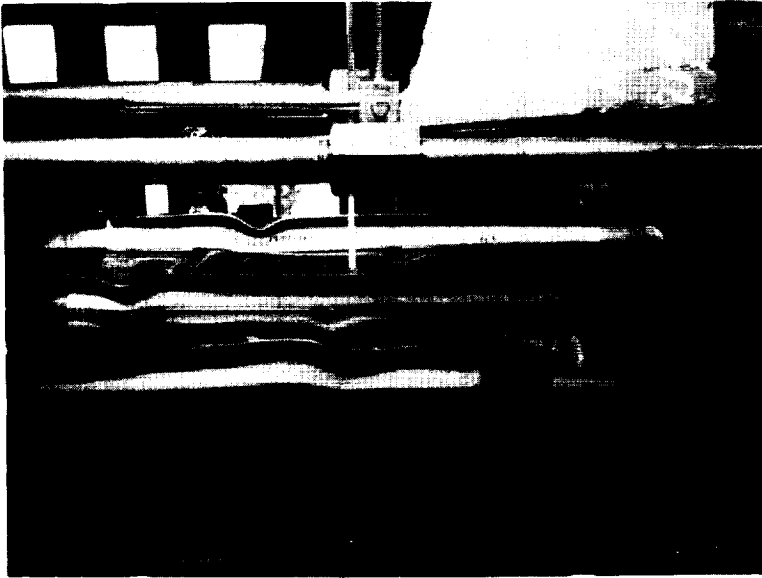

Figure 27.- Panel PC-4 under  
14,120 pounds  
after subjection to 21,475  
pounds.

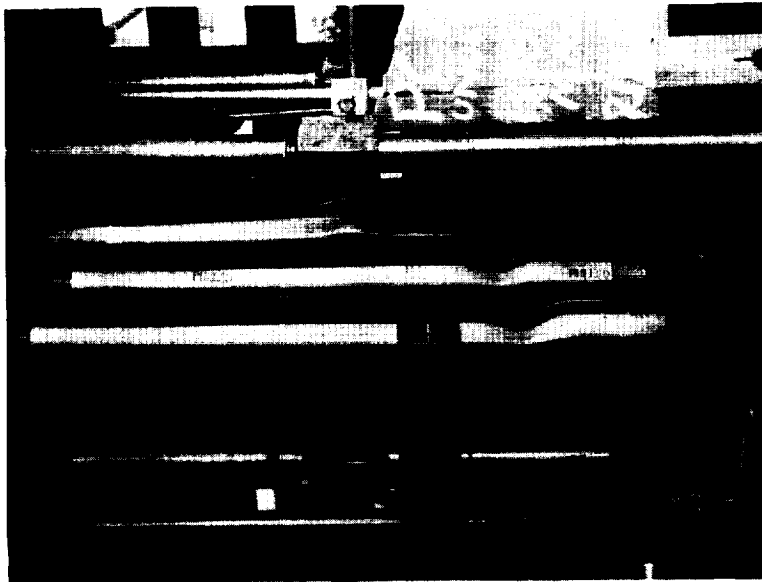

Figure 26.- Panel PC-2 under  
14,395 pounds  
after subjection to 21,800  
pounds.



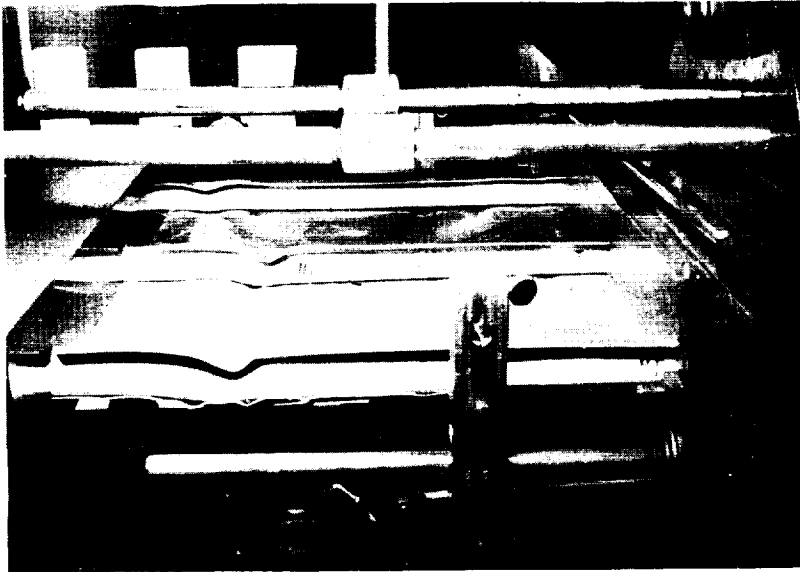

Figure 29.- Panel PC-8 under  
13,400 pounds  
after subjection to 21,490  
pounds.

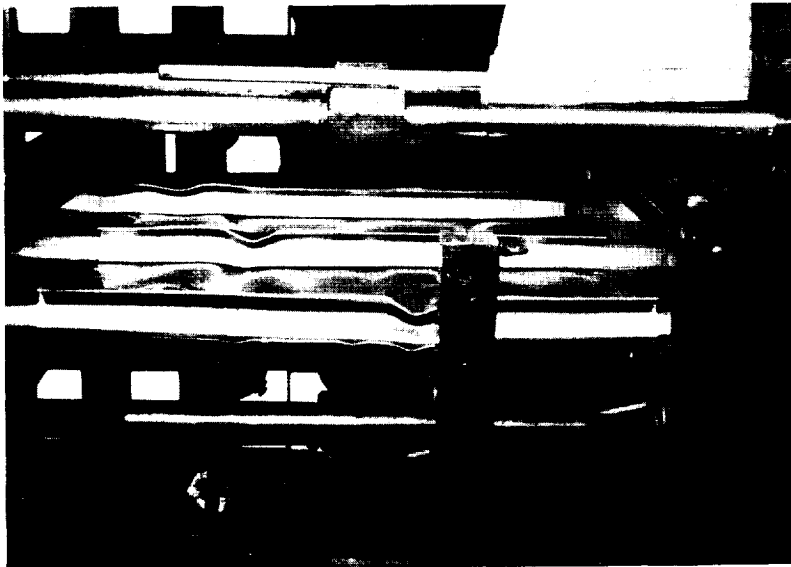
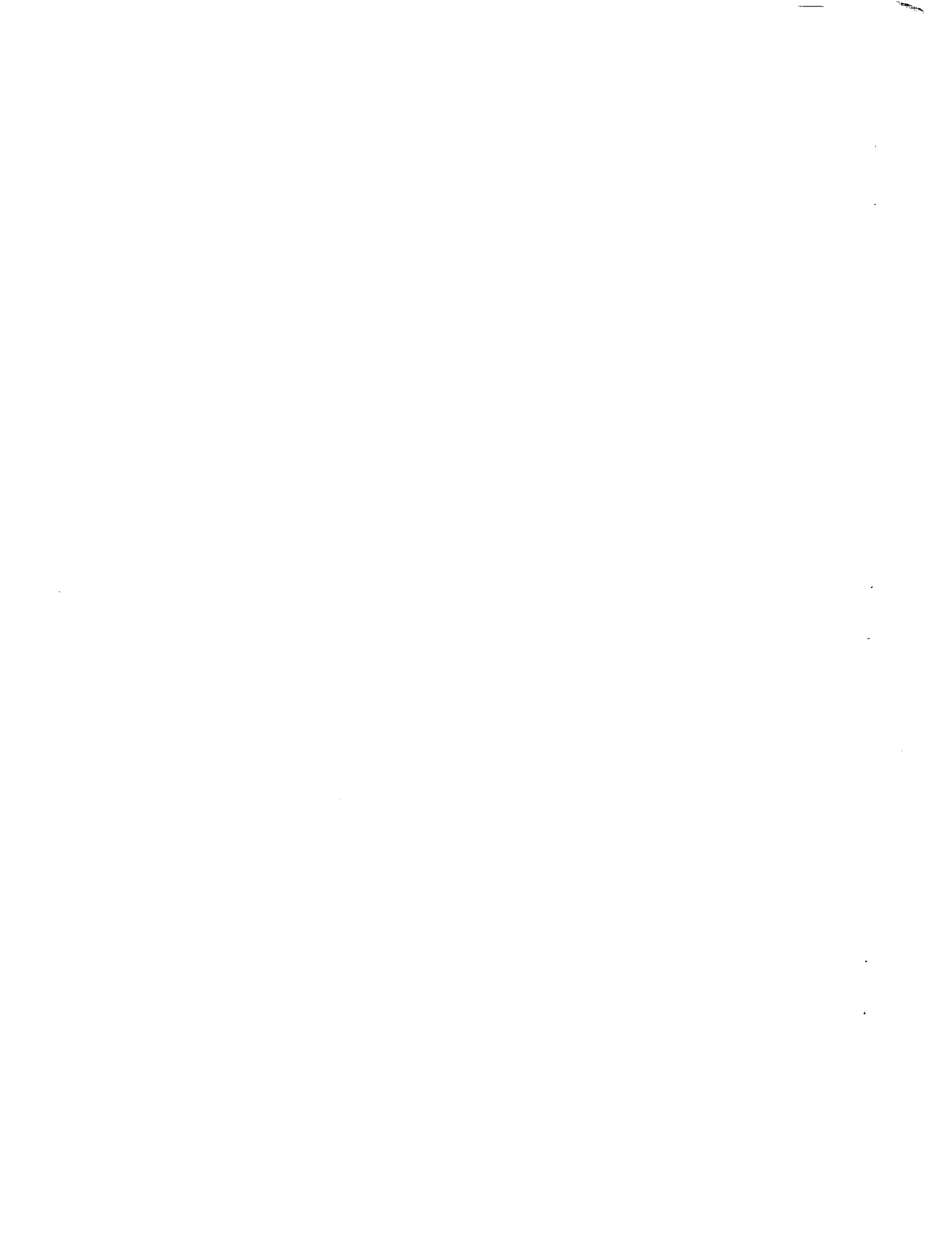

Figure 28.- Panel PC-6 under  
13,570 pounds  
after subjection to 20,250  
pounds.



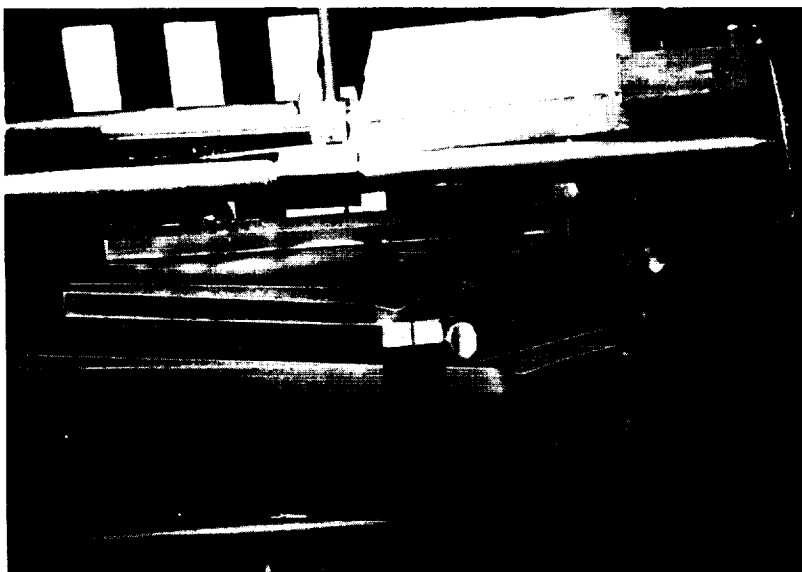

Figure 31.- Panel PD-4 under  
7,525 pounds  
after subjecting to 22,225  
pounds.

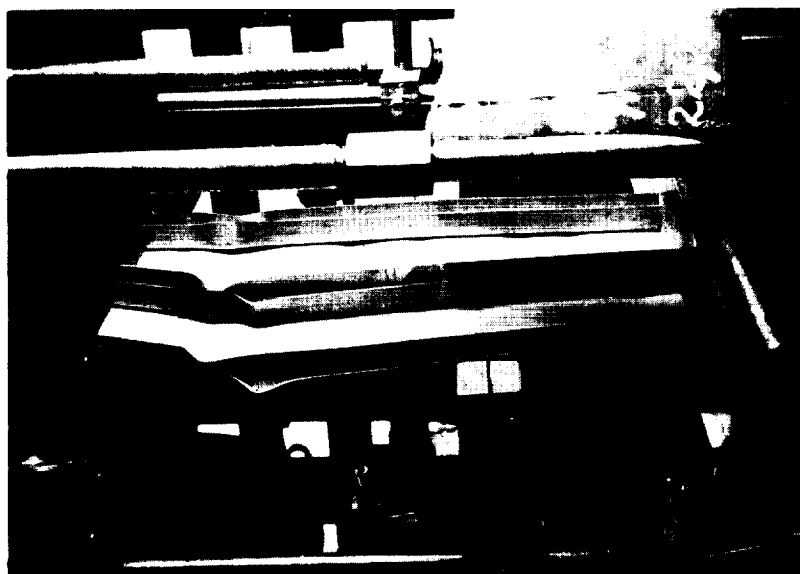

Figure 30.- Panel PD-2 under  
8,950 pounds  
after subjecting to 22,020  
pounds.



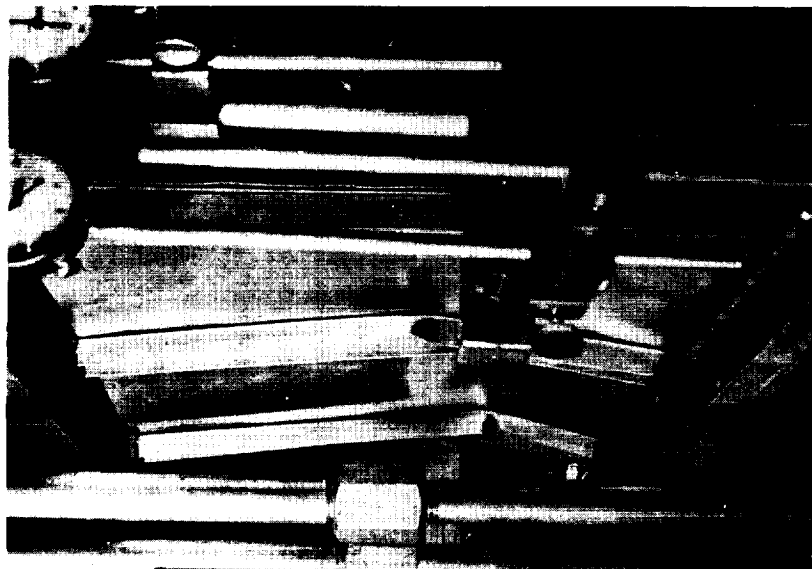

Figure 33.- Panel PD-8 under 6,185 pounds after subjection to 22,000 pounds.

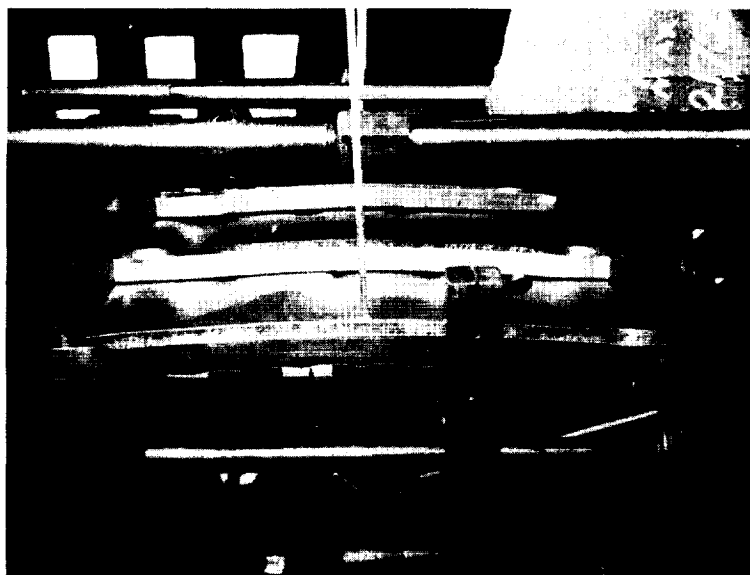

Figure 32.- Panel PD-6 under 15,780 pounds after subjection to 21,750 pounds.



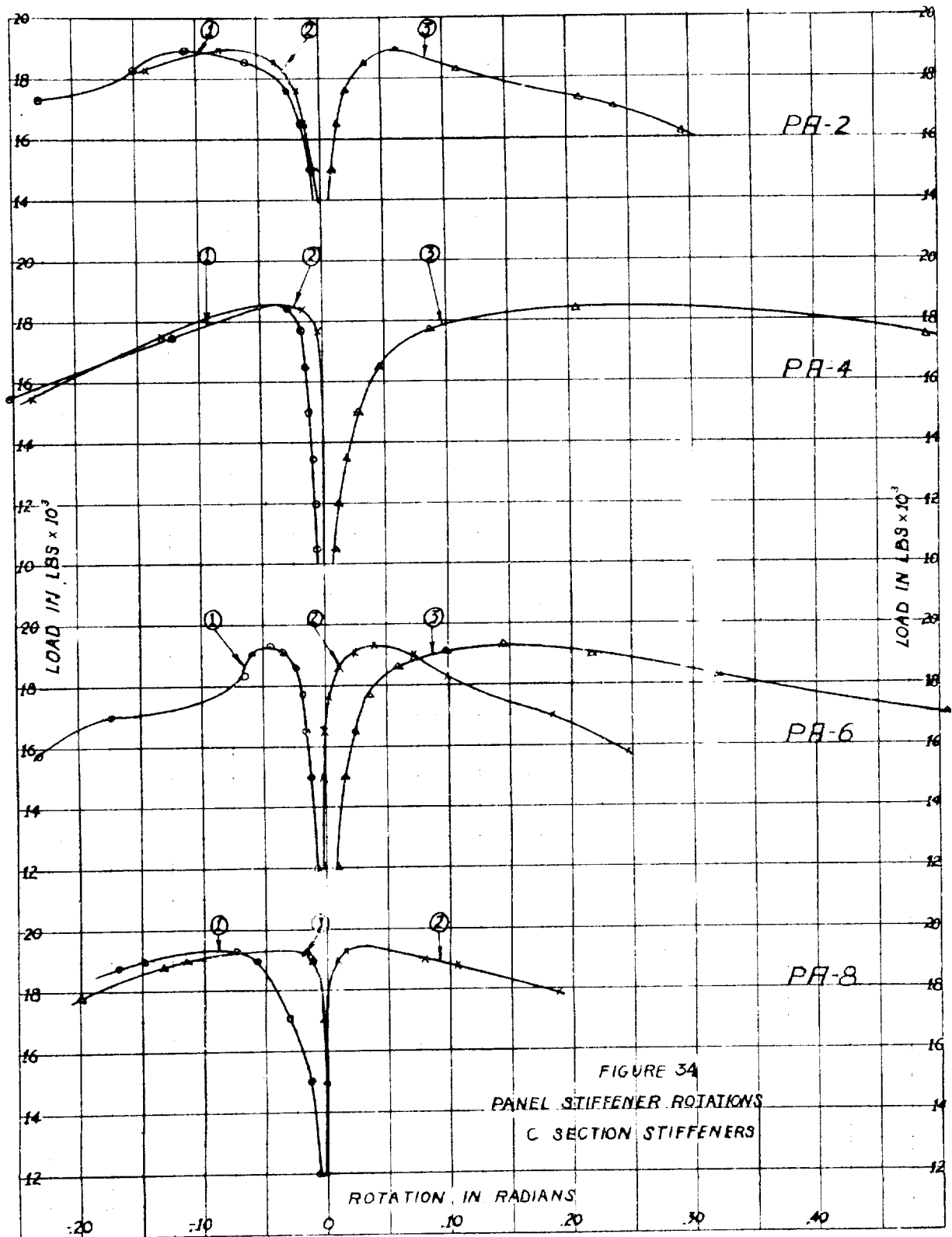
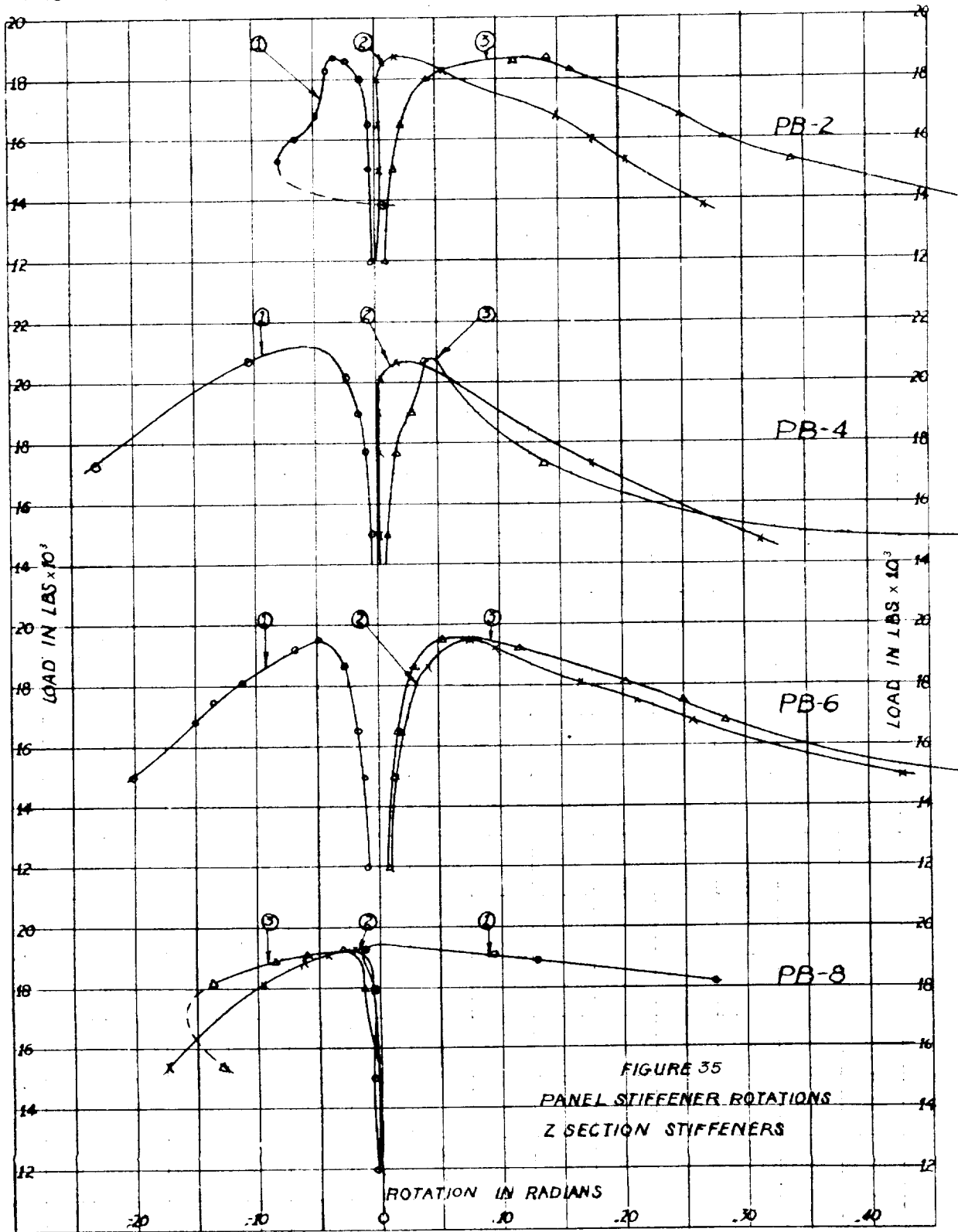
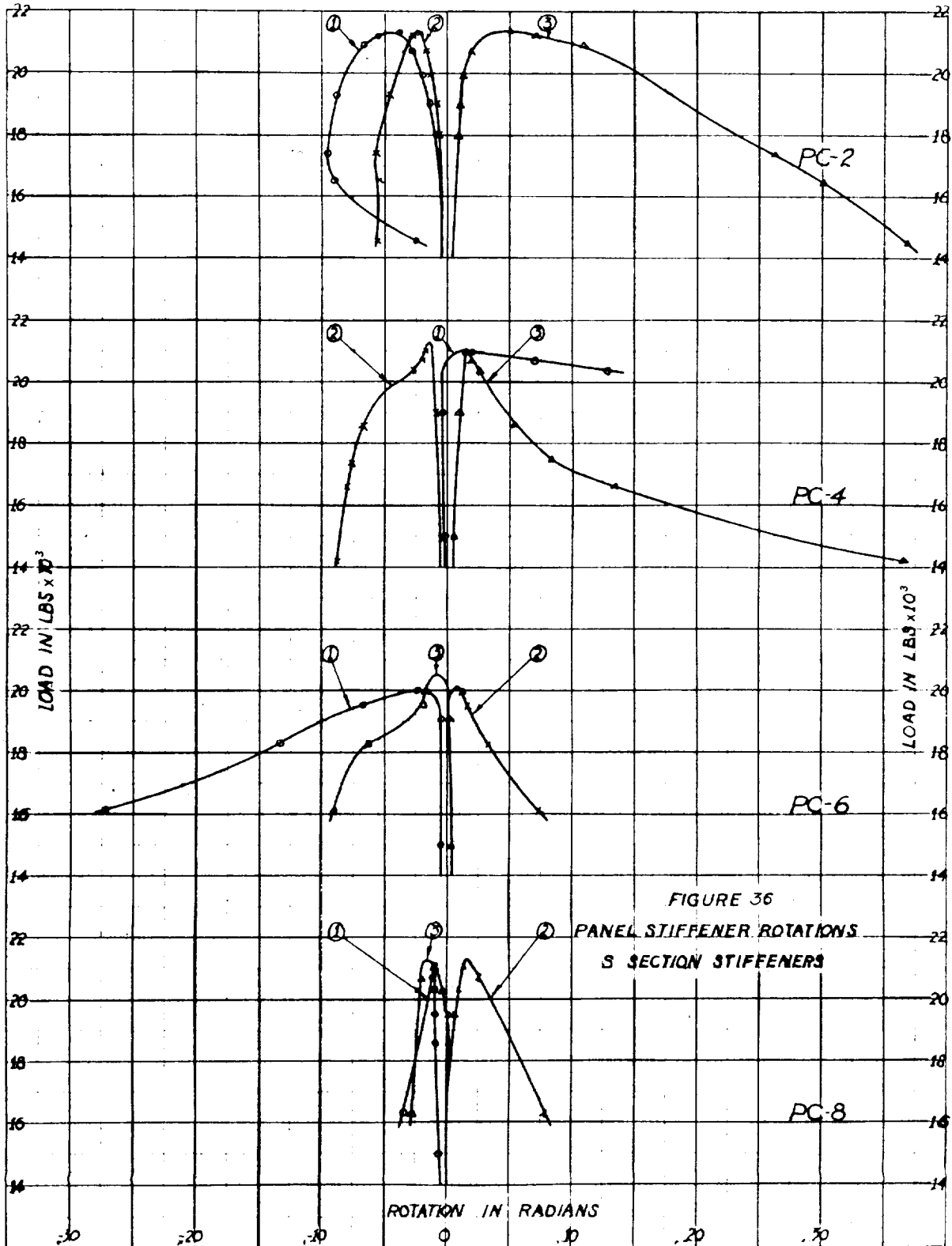

FIGURE 34  
PANEL STIFFENER ROTATIONS  
C SECTION STIFFENERS











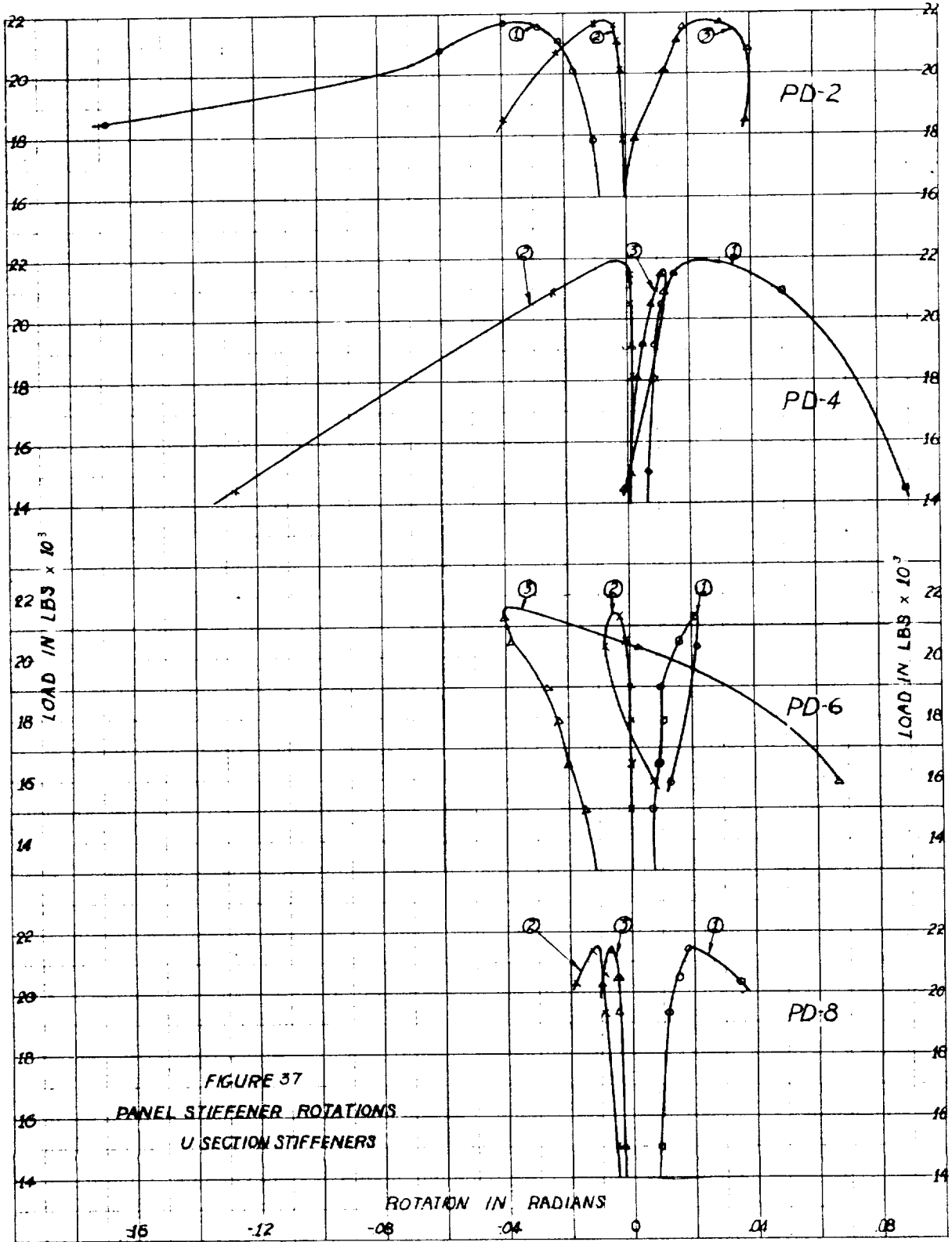

~~RESTRICTED~~

**TITLE:** Tests of Flat Panels with Four Types of Stiffeners

**ATI- 7509**

REVISION

(None)

**AUTHOR(S):** Niles, A. S.

**ORIGINATING AGENCY:** National Advisory Committee for Aeronautics, Washington, D. C.

ORIG. AGENCY

TN

**PUBLISHED BY:** (Same)

PUBLISHING AGE

U.S.

**DATE**  
Jan'43

**DOC. CLASS.**  
Restr.

**COUNTRY**  
U.S.

**LANGUAGE**  
Eng.

**PAGES**  
59

**ILLUSTRATIONS**  
photos, tables, diagr, graphs

**ABSTRACT:**

Specimens were flat-end columns of different lengths. C-, U-, S-, and Z-stiffeners were used in duplicate pairs. The test data include the maximum loads carried, action of the panels after the maximum load had been passed, amount of twisting of the stiffeners, and photographs showing the character of failure of many of the panels.

**DISTRIBUTION:** Request copies of this report only from Originating Agency

**DIVISION:** Stress Analysis and Structures (7)

**SECTION:** Structural Design and Details (3)

**SUBJECT HEADINGS:** Panels, Stiffened - Strength (68747.7)

**ATI SHEET NO.:** R-7-3-4

Air Documents Division, Intelligence Department  
Air Materiel Command

**AIR TECHNICAL INDEX**

Wright-Patterson Air Force Base  
Dayton, Ohio

Classification cancelled

APR 29 1949

Classification cancelled per authority  
of List NACA dd. 28 Sept 1945  
*George R. Jordan, USCO. 29 Apr 1949*