

UNCLASSIFIED

AD NUMBER

ADB814183

CLASSIFICATION CHANGES

TO: unclassified

FROM: restricted

LIMITATION CHANGES

TO:
Approved for public release, distribution unlimited

FROM:
Distribution authorized to DoD only;
Administrative/Operational Use; JUL 1940.
Other requests shall be referred to
National Aeronautics and Space
Administration, Washington, DC. Pre-dates
formal DoD distribution statements. Treat
as DoD only.

AUTHORITY

E.O. 10501 dtd 5 Nov 1953; NASA TR Server website

THIS PAGE IS UNCLASSIFIED

Reproduced by
AIR DOCUMENTS DIVISION

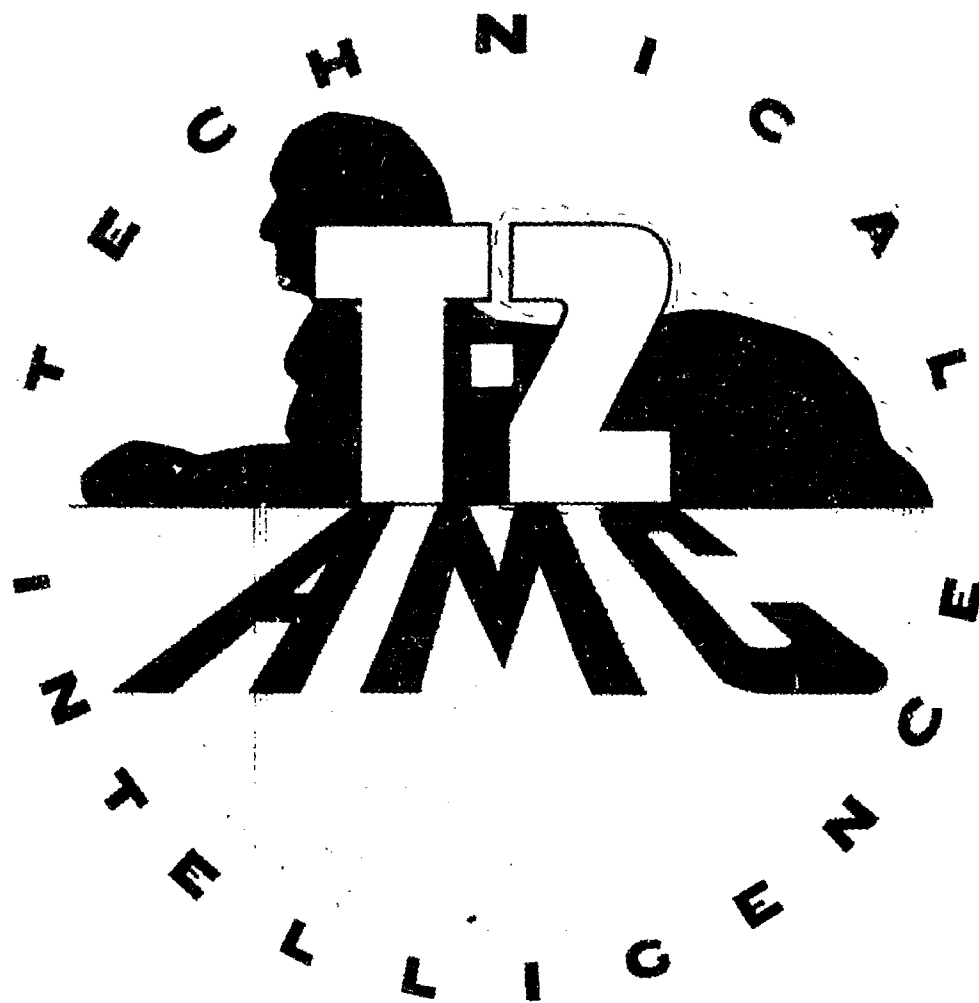

HEADQUARTERS AIR MATERIEL COMMAND

WRIGHT FIELD, DAYTON, OHIO

U.S. GOVERNMENT

IS ABSOLVED

FROM ANY LITIGATION WHICH MAY

ENSUE FROM THE CONTRACTORS IN -

FRINGING ON THE FOREIGN PATENT

RIGHTS WHICH MAY BE INVOLVED.

HEADQUARTERS AIR MATERIEL COMMAND

WRIGHT FIELD, DAYTON, OHIO

RESTRICTED

D52.417 / 74

TECHNICAL NOTES

NATIONAL ADVISORY COMMITTEE FOR AERONAUTICS

ATL No. 7227

No. 766

A STUDY OF THE AIR MOVEMENTS IN
TWO AIRCRAFT-ENGINE CYLINDERS

By Dana W. Lee
Langley Memorial Aeronautical Laboratory

REPRODUCED FROM
NATIONAL BUREAU OF STANDARDS LIBRARY
Washington, D.C.

Washington
July 1946

NATIONAL ADVISORY COMMITTEE FOR AERONAUTICS

TECHNICAL NOTE NO. 766

A STUDY OF THE AIR MOVEMENTS IN
TWO AIRCRAFT-ENGINE CYLINDERS

By Dana W. Lee

SUMMARY

Studies were made of the air movements in the N.A.C.A. glass-cylinder apparatus using cylinder heads similar to those on the Wright R-1820-G engine and the Pratt & Whitney Wasp engine as modified by the Eclipse Aviation Corporation to use fuel-injection equipment. The air movements were made visible by mixing small feathers with the air; high-speed motion pictures were then taken of the feathers as they swirled about inside the glass cylinder. The test-engine speeds were 350, 500, and 1,000 rpm. Motion pictures were also taken of gasoline sprays injected into the cylinder during the intake stroke.

The air flow produced by each cylinder head is described and some results of the velocity measurements of feathers are presented. The apparent time intervals required for vaporization of the gasoline sprays are also given.

INTRODUCTION

In the design of spark-ignition engines employing fuel injection, the principle is well established that air movement greatly assists the mixing of the fuel and the air and thereby improves engine performance. (See reference 1.) In a previous report (reference 2) it was shown that air movements in an engine cylinder could be controlled to a large extent by the use of shrouded valves and to a lesser extent by the shape of the intake-air passage. The purpose of the present tests was to determine the direction and velocity of the air flow in an engine cylinder when heads similar to those on two modern radial aircraft engines were used. One of the heads was similar to that used on the Wright R-1820-G engine, and the other was similar to that developed by the Eclipse Aviation Corporation for use with

a Pratt & Whitney Wasp engine equipped with a fuel-injection system. Previous tests had indicated that the R-1820-G engine had an unusually high degree of air turbulence, and the Wasp engine had been modified for the express purpose of creating a certain air movement.

The tests described in this report were made in 1939 with the N.A.C.A. glass-cylinder apparatus at the Committee's Langley Field laboratories.

APPARATUS

The glass-cylinder apparatus used for this investigation has been described in reference 2. Briefly, it consists of a single-cylinder test engine modified by the insertion of a glass cylinder between the top of the steel cylinder and the lower edge of the cylinder head. The inside diameter of the glass cylinder is the same as that of the steel one, and its length is equal to the stroke of the engine. A hollow aluminum extension of the engine piston moves within the glass cylinder with a radial clearance of 0.016 inch.

The mechanical details of the apparatus have been somewhat altered for the present tests. As shown in figure 1, the valves are now operated by push rods and rocker arms. A single steel casting forms the engine cylinder and the support for the glass cylinder. Four openings in the casting permit observation of the inside of the glass cylinder during operation.

Sectional and plan views of the two cylinder heads used are shown in figures 2 and 3. All dimensions for the insides of the heads, the valves, and the intake and exhaust passages were obtained by scaling down the dimensions of the corresponding aircraft engine by the ratio of the bore of the glass cylinder to the bore of the aircraft-engine cylinder. Outside dimensions of the heads are of no importance in this case. The aircraft-engine heads themselves were not used because it was impracticable to obtain new glass cylinders, steel cylinders, and pistons of the proper diameters.

The head shown in figure 2, typical of those used on present air-cooled radial engines, has a hemispherical head and two large valves. In this head, however, the angle be-

tween the center line of the intake passage and the plane containing the center lines of the valve stems is only 36° instead of the usual 90° . Spark-plug holes were omitted, but an extra hole in the center of the head was made so that a fuel-injection valve could be installed.

The head shown in figure 3 was scaled down from a Pratt & Whitney Wasp modified by the Eclipse Aviation Corporation for use with their fuel-injection equipment. The intake-valve seat is higher than the exhaust-valve seat, and a ledge (marked A in fig. 3) protrudes inward at the bottom of the head and extends for about 50° on either side of the plane shown in the sectional view. Spark-plug holes were again omitted, but in this case the hole for the injection valve is in the same position as in the aircraft-engine head, to one side of the center and slanting inward. The only prominent feature of the aircraft engine not copied in the glass-cylinder apparatus is a series of concentric grooves in the top of the piston. Their purpose is to catch and vaporize any liquid fuel from the injection valve reaching the piston, and their effect on the air flow within the cylinder is negligible.

The bore of the glass-cylinder apparatus is 5 inches, the stroke is 7 inches, and in these tests the connecting-rod length was $14\text{-}\frac{3}{4}$ inches. The valve timing was adjusted for each head to be as near as possible to that of the corresponding aircraft engine.

The fuel-injection valve used for both heads is that supplied by the Eclipse Aviation Corporation for use with their modification of the Wasp engine. It produces a hollow conical spray with a divergent angle of about 30° . A valve-opening pressure of 600 pounds per square inch was used.

The timing of the intake and the exhaust valves and of the injection valve is given in table I for each of the two heads.

TABLE I

Valve and Fuel-Injection Timings

Conditions	R-1820-G	Eclipse-Wasp
Intake valve opens	20° B.T.C.	27° B.T.C.
Intake valve closes	30° A.B.C.	81° A.B.C.
Exhaust valve opens	90° A.T.C.	100° A.T.C.
Exhaust valve closes	10° B.T.C.	14° A.T.C.
Fuel injection begins	50° A.T.C.	50° A.T.C.
Fuel injection ends	95° A.T.C.	130° A.T.C.

TESTS

The test method was the same as that described in reference 2. The engine was driven at a constant speed by a large electric motor, and small particles of white goose down were mixed with the incoming air. A high-speed motion-picture camera, taking pictures at a rate of more than 2,000 frames per second, recorded the motion of the feathers as they passed through the engine. When these pictures were projected at the usual rate of 16 per second, the velocities of the feathers appeared to be less than 1 percent of their actual velocities, and their motion could be studied and analyzed. Pictures were also taken of gasoline sprays injected into the cylinders. Engine-test speeds were 350, 500, and 1,000 rpm.

For the R-1820-G head, motion pictures were taken with the camera axis in the plane of the valve stems, but for the Eclipse-Wasp head, pictures were taken from that position and also from a position at right angles to it.

RESULTS AND DISCUSSION

R-1820-G Head

The results of some of the tests described in reference 2 led to the expectation that the unusual angular position of the intake passage of the R-1820-G head would result in rapid rotation of the air about the cylinder axis, but the motion pictures showed that only a very slow rotation of the charge was built up during the second half of the intake stroke and that the rotation continued at a slowly reducing rate for the rest of the cycle. The rate of rotation was not measured, but it was not more than once per engine revolution. The air in the cylinder was in a very turbulent state, however, during the intake stroke but most of the turbulence died out during the compression stroke.

Air-flow velocities were determined by projecting the motion pictures one at a time and measuring the distances that various feathers had moved in the interval between pictures. The results are shown for the three test speeds in figure 4. A discussion of the errors involved in this method of measuring the air velocity is given in reference 2. In the computation of the air velocity at the inlet valve, the air was assumed to be inelastic. A comparison of figure 4 with the figures in reference 2, which give air velocities in the N.A.C.A. universal test-engine head, shows that both the air velocity at the inlet valve and the feather velocities were about 20 percent higher for the R-1820-G head than for the test-engine head.

Motion pictures of gasoline sprays injected from a valve in the center of the head showed that the sprays did not impinge on the piston or the cylinder walls, and that the turbulence of the air broke up the spray very quickly after the end of the injection period. Complete clearing of all fuel mist from the air in the cylinder was taken as an indication of complete fuel vaporization; the crank angles at which such clearing occurred are given in table II.

TABLE II

Crank Angles for Fuel Vaporization

Engine	Engine speed (rpm)	Crank angle at which cylinder clears (deg B.T.C. on compression stroke)	Time after end of injection	
			Crank deg	sec
R-1820-G	350	97	136	0.065
	500	84	144	.048
	1,000	63	166	.028
Eclipse- Wasp	350	129	133	.055
	500	121	146	.048
	1,000	99	167	.028

Eclipse-Wasp Head

The Eclipse-Wasp head employs a partially masked inlet valve. The air movement in the cylinder was, therefore, expected to be similar to that obtained with the N.A.C.A. universal test-engine head when both inlet valves were turned so that the shrouds on them were nearest the cylinder wall. (See arrangement F or G of reference 2.) The motion pictures showed that the air movement obtained with the Eclipse-Wasp head was very similar to that obtained with the shrouded valves in the universal head. After leaving the intake port, the air moved across the top of the cylinder towards the exhaust-valve head, thence down to the piston, across it, and back up to the top of the cylinder again. The movement was less rapid than it was with the universal head and more turbulence was present. The air movements created during the intake stroke continued throughout the compression stroke but at reducing velocities. During the last two strokes of the cycle, however, the only air movement was a slight turbulence.

Gasoline sprays injected from the position in the

cylinder head shown in figure 3 were broken up in about the same time as they were in the R-1320-G head; and the data in table II indicate, at each test speed, that the vaporization time was about the same in the two cylinder heads.

Air velocities at the three test speeds are shown in figure 5. The velocities through the inlet valve and the measured air velocities are both about 30 percent lower than for shroud arrangement F in the universal test-engine head (reference 2).

CONCLUSIONS

1. The air movement in an engine cylinder using a head similar to those on a Wright R-1320-G engine was very turbulent during the intake stroke. During the second half of the intake stroke, a very slow rotation of the air about the cylinder axis began. The turbulence died out during the compression stroke, but the rotation continued at a reducing rate until the end of the cycle.

2. The air movement in an engine cylinder using a head similar to those on an Eclipse modified Wasp engine took the form of a vertical loop during the intake and the compression strokes; some turbulence was also present. The loop movement died out before the beginning of the expansion stroke, leaving only a slight turbulence.

3. There appeared to be no difference in the time required for vaporization of gasoline sprays injected into the cylinder when the R-1320-G and the Eclipse-Wasp heads were used.

Langley Memorial Aeronautical Laboratory,
National Advisory Committee for Aeronautics,
Langley Field, Va., May 24, 1940.

REFERENCES

1. Schey, Oscar W.: Performance of Aircraft Spark-Ignition Engines with Fuel Injection. (Paper presented before S.A.E., Detroit, Nov. 20, 1939, Washington, Mar. 14, 1940).
2. Lee, Dana W.: A Study of Air Flow in an Engine Cylinder. T.R. No. 653, N.A.C.A., 1939.

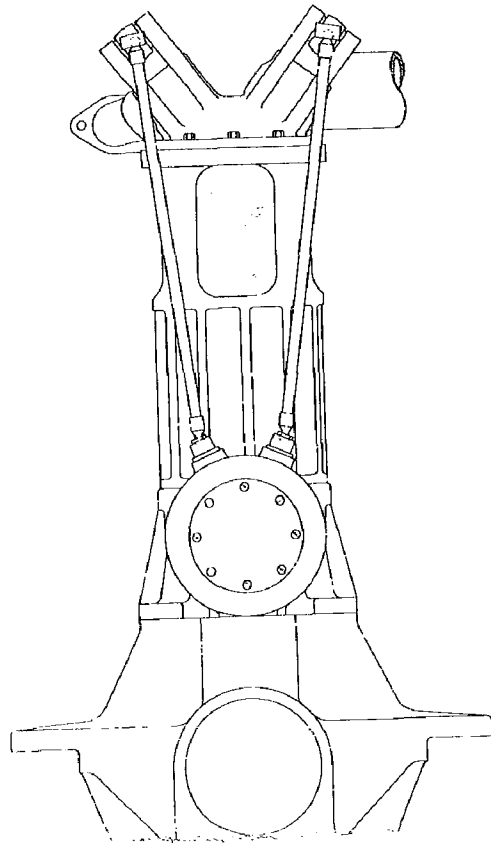

Figure 1. Dual cylinder separator with swirl-inducing head.

Figs. 2,3.

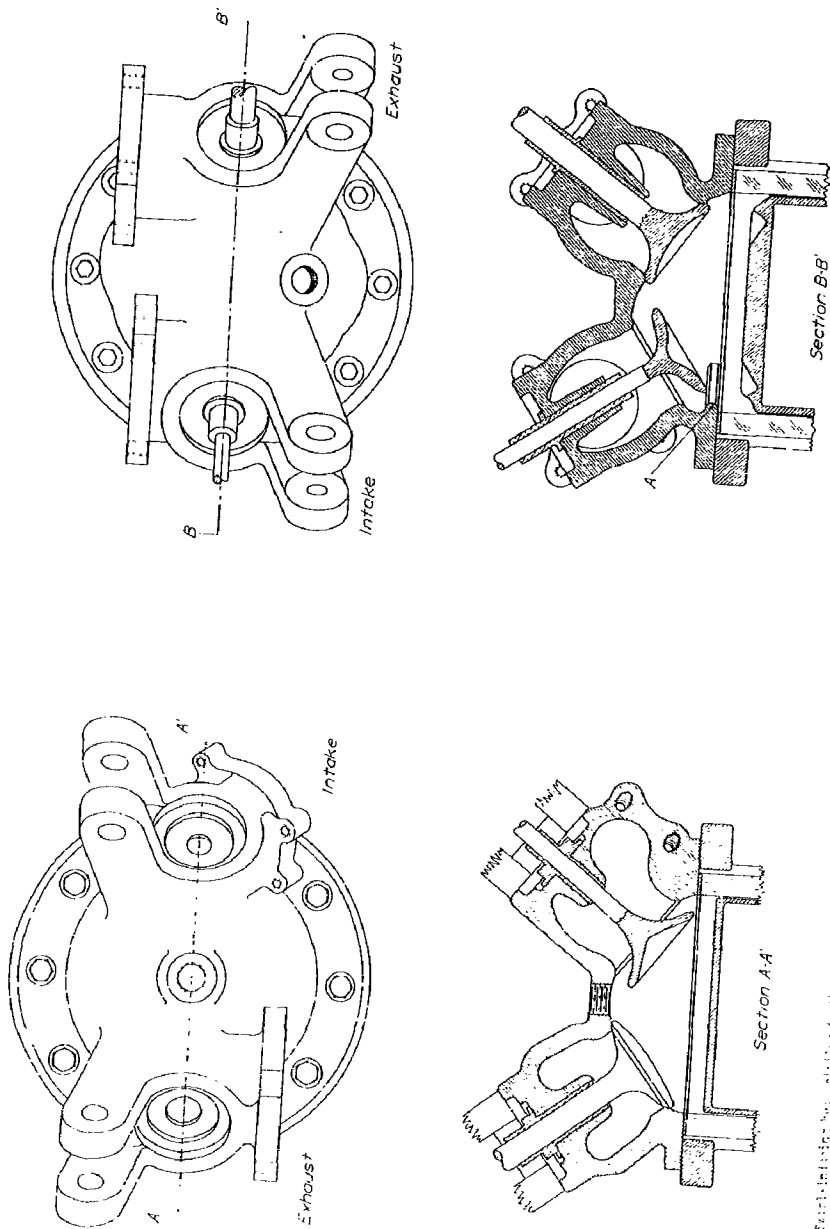
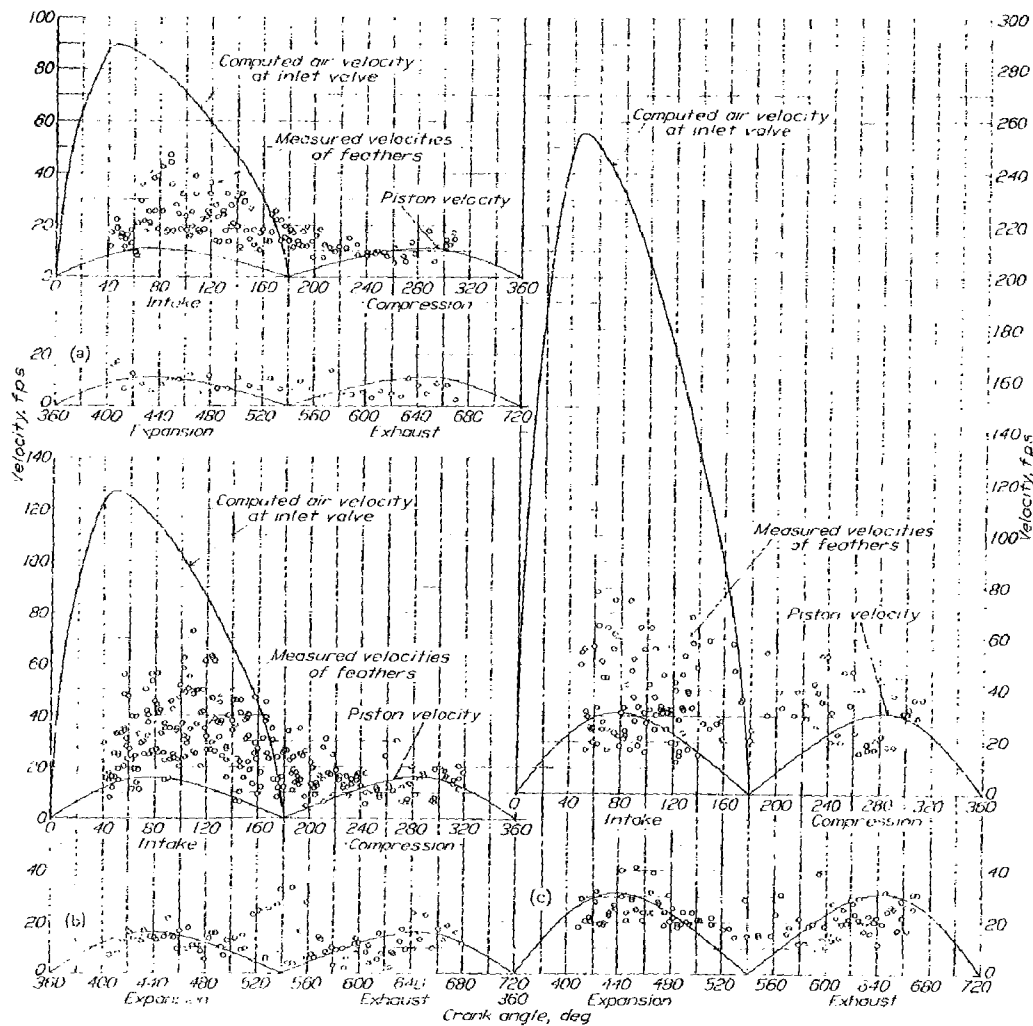

Figure 2. - Split-inductor head similar to that developed by the Eclipse Aviation Corporation for use with the Pratt & Whitney gas engine.

Figure 3. - Split-inductor head similar to that developed by the Eclipse Aviation Corporation for use with the Pratt & Whitney gas engine.



(a) Engine speed, 360 r.p.m. (b) Engine speed, 500 r.p.m. (c) Engine speed, 1,600 r.p.m.

Figure 4 a to c. - Velocities of feathers when using F-1R20-G head.

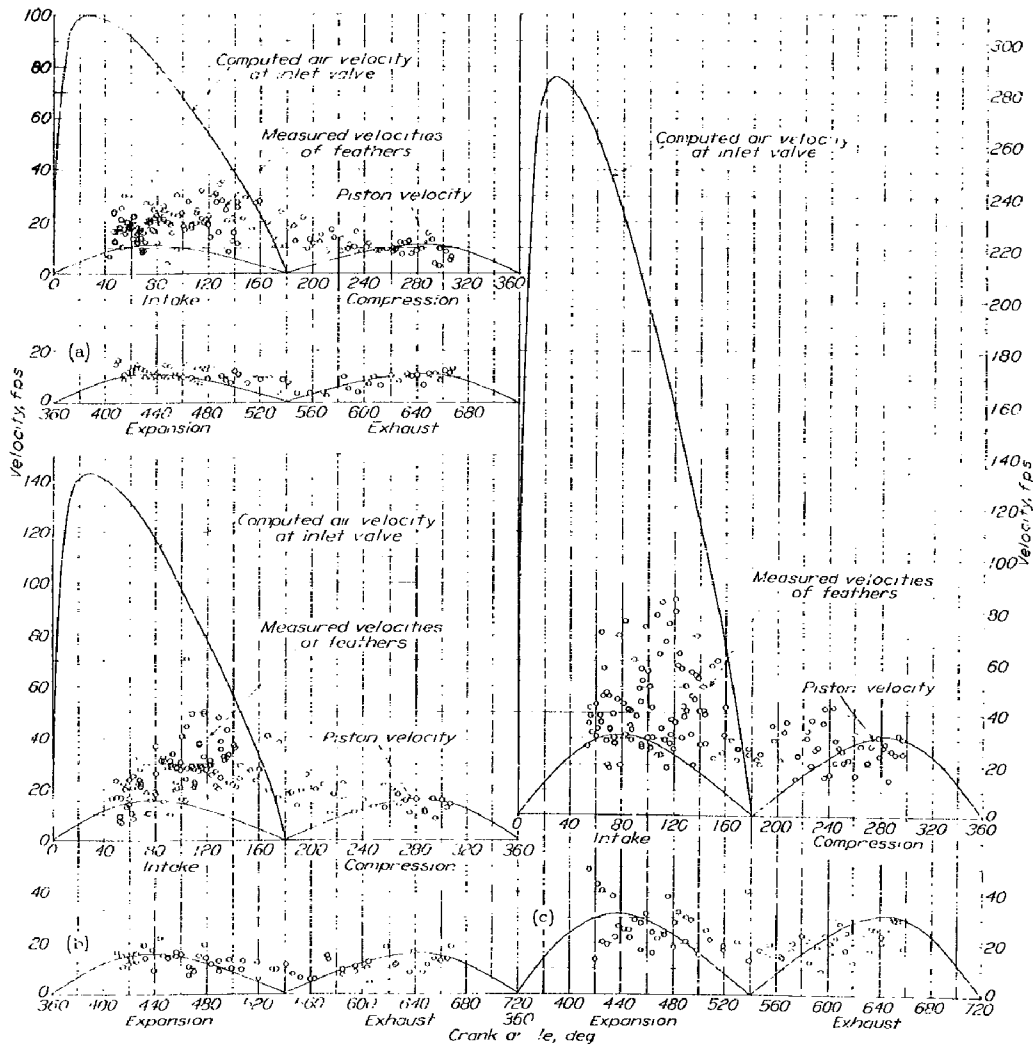

(a) Engine speed, 750 r.p.m. (b) Engine speed, 500 r.p.m. (c) Engine speed, 1,000 r.p.m.

Figure 5 a to c. - Velocities of feathers when using Eclipse-Wasp head.

RFFI - C

306

A.T.I.

7794

FORM 800 A (10 FEB 47)

Lee, Dana W.

~~RESTRICTED~~
DIVISION: Power Plants, Reciprocating (6) 7-6-14-8
SECTION: Testing (14) 11741-13-5
CROSS REFERENCES: Combustion Chambers - Turbulence
(23902)

ATI- 7794
ORIG. AGENCY NUMBER
TN-766

REVISION

AUTHOR(S)

AMER. TITLE: A study of the air movements in two aircraft-engine cylinders

FORG'N. TITLE: EO 10501 dd 5 NOV 1953

ORIGINATING AGENCY: National Advisory Committee for Aeronautics, Washington, D.C.

TRANSLATION:

COUNTRY	LANGUAGE	FORG'N. CLASS	U. S. CLASS.	DATE	PAGES	ILLUS.	FEATURES
U.S.	Eng.		Restr.	Jul '40	12	7	tables, graphs, drwgs

ABSTRACT

Tests were made to determine direction and velocity of air flow in a glass engine cylinder when cylinder heads similar to those on two radial engines were used. Air movements were made visible by mixing small feathers with the air. Motion pictures were taken of the feathers and of gasoline sprays injected into the cylinder. Velocities of feathers at various engine speeds are charted. Nature of air movement is discussed.

NOTE: Requests for copies of this report must be addressed to: N.A.C.A., Washington, D. C.

T-2, HQ, AIR MATERIEL COMMAND

AIR TECHNICAL INDEX
RESTRICTED

WRIGHT FIELD, OHIO, USAAF

WF-O-31 MAR 47 23,500