

UNCLASSIFIED

AD NUMBER

ADB814415

CLASSIFICATION CHANGES

TO: unclassified

FROM: restricted

LIMITATION CHANGES

TO:
Approved for public release; distribution is unlimited.

FROM:
Distribution authorized to DoD only; Administrative/Operational Use; JUL 1944. Other requests shall be referred to National Aeronautics and Space Administration, Washington, DC. Pre-dates formal DoD distribution statements. Treat as DoD only.

AUTHORITY

NACA list dtd 28 Sep 1945; NASA TR Server website



JUL 15 1944

RESTRICTED

NATIONAL ADVISORY COMMITTEE FOR AERONAUTICS

TECHNICAL NOTE

No. 933

APPLICABILITY OF SIMILARITY PRINCIPLES TO STRUCTURAL MODELS

By J. N. Goodier and W. T. Thomson
Cornell University



NACA LIBRARY
LANGLEY MEMORIAL AERONAUTICAL
LABORATORY
Langley Field, Va.

Washington
July 1944

CLASSIFIED DOCUMENT

This document contains classified information affecting the National Defense of the United States within the meaning of the Espionage Act, USC 50:31 and 32. Its transmission or the revelation of its contents in any manner to an unauthorized person is prohibited by law. Information so classified

may be imparted only to persons in the military and naval Services of the United States, appropriate civilian officers and employees of the Federal Government who have a legitimate interest therein, and to United States citizens of known loyalty and discretion who of necessity must be informed thereof.

RESTRICTED

RESTRICTED

NATIONAL ADVISORY COMMITTEE FOR AERONAUTICS

TECHNICAL NOTE NO. 933

APPLICABILITY OF SIMILARITY PRINCIPLES TO STRUCTURAL MODELS

By J. N. Goodier and W. T. Thomson

I. SIMILARITY PRINCIPLES FOR STRUCTURAL AND DYNAMICAL MODELS

SUMMARY

A systematic account is given in part I of the use of dimensional analysis in constructing similarity conditions for models and structures. The analysis covers large deflections, buckling, plastic behavior, and materials with nonlinear stress-strain characteristics, as well as the simpler structural problems.

1. INTRODUCTION

Similarity principles for guidance and interpretation of model tests in engineering frequently have been based on the differential equations of the problem or on more or less intuitive conceptions of what similarity means, as, for example, in fluid mechanics when similarity is taken to mean that the ratios of inertia, viscous, and gravity forces at corresponding points are the same, or that the streamline patterns are geometrically similar. It is now recognized, however, that it is much more satisfactory to apply the general dimensional analysis of E. Buckingham (reference 1) and P. W. Bridgman (reference 2). This method has been thoroughly developed in general physics and fluid mechanics, but apparently not in structural mechanics.

The question as to what is meant by structural similarity frequently can be answered in a very simple manner. But the complications implied by the use of several materials in a single structure, the use of models not made of the same material as the prototype, buckling and related behavior, plastic flow, thermal stress, and the

RESTRICTED

various combinations of these, besides the problems of fluid-structure combinations, as for instance in dams, wind vibrations in suspension bridges, and flutter, require an analysis more comprehensive than immediate intuitive notions can well supply. Such an analysis can be as readily made, by the methods of Buckingham and Bridgman, in solid mechanics, or for solid plus fluid problems, as in fluid mechanics. Nonlinear problems, buckling criterions, plastic flow, all can be dealt with, although at first sight the lack of adequately defined physical constants to characterize the inelastic properties of materials seems to put obstacles in the way of dimensional analysis, with its primary requirement that a list of symbols concerned be drawn up.

The author is indebted to Drs. Tuckerman, Ramberg, and Osgood for the suggestion that an investigation of similarity under affine stress-strain relations would be desirable.

2. DIMENSIONAL ANALYSIS AND SIMILARITY PRINCIPLES - NONDIMENSIONAL QUANTITIES - DIMENSIONAL CONSTANTS

Only a brief introductory account of dimensional analysis is given here. For a full account the reader is referred to references 1 and 2.

As Bridgman (reference 2) emphasizes, the first object of dimensional analysis is to make sure that the formula for a required quantity, as the solution of a definite physical problem, will be valid no matter what system of units is used to give numerical values to the quantities concerned, just as the bending stress formula $\sigma = Mc/I$ yields the same physical stress in tons per square foot, if tons and feet are used as units for M , c , and I , as it does in pounds per square inch, if pounds and inches are used as units.

This validity in all unit systems is, of course, equally well expressed by the statement that $\frac{\sigma I}{Mc}$ is the

same in all unit systems, and this is what is meant by "dimensionless."

Let the list of symbols concerned in a problem be $x_1, x_2, x_3, \dots, x_n$ being sought in terms of the others.

There usually will be several dimensionless groups (products of powers of the symbols), say $\Pi_1, \Pi_2,$ and so forth, and it may be shown that the number of independent groups is equal to the number of original symbols less the number of fundamental units. Buckingham's Π -theorem states that, when there is only one relation between the symbols, it must, in order to be valid in all unit systems, take the form

$$\Pi_1 = f(\Pi_2, \Pi_3, \dots) \quad (1)$$

with $f(\)$ as a constant if there is only one dimensionless group Π_1 . When there is more than one relation between the symbols, the requirement of validity in all unit systems can be satisfied without dimensional homogeneity, as Bridgman illustrates by adding $v = gt$ to

$$s = \frac{1}{2}gt^2 \quad \text{to obtain} \quad v + s = gt + \frac{1}{2}gt^2.$$

The problem contemplated so far is the following: Given a set of symbols, representing the numerical measures of the corresponding physical quantities (as soon as a unit system is selected), what restrictions on the functional relation between them are implied by the requirement that it shall be valid in all unit systems? In contemplating a change of units, of course, only a single feature of a definite physical system is considered - for example, the stress of a given kind at a given point of a given structure with given loads. This, however, is to be obtained from a formula of the type of equation (1). In such a formula it is supposed that all quantities which may be represented by variable numbers, including physical variables and physical "constants" which may change in numerical value with change of unit system, and so are not dimensionless, are represented by symbols. The functional relation then holds for variations of its arguments, no matter how produced. The form (equation (1)) so arranges the relation that in fact no variations in the Π 's, and thus in the value of the function, occur when the numerical value of the original symbols changes by change of unit system.

But the functional relation (equation (1)) is valid

for all values of the symbols in the ranges permitted by physical considerations, just as $\sigma I/Mc = 1$ is valid for all permitted values of σ , I , M , c . Changes can thus be contemplated in the values of the symbols corresponding not to a change of units for a given physical system, say a structure with given loads, but to a passage from this to another structure with other loads, of course, within the class of structures and loads covered by the contemplated formula, as, for instance, the class of beams and loads covered by $\sigma I/Mc = 1$. Then without knowing the functional form f in equation (1), it can be said that if the groups Π_2 , Π_3 - - + in equation (1) have the same values in the two systems, then $f(\)$ and therefore Π_1 will have the same value for the two systems.¹ The equality of the groups in $f(\)$ thus provides a set of "similarity conditions" governing the construction of a model, and equality of the Π_1 's for model and structure then provides a similarity relation by which a measurement on the model can be made to yield the corresponding quantity for the structure. This analysis is applied in what follows to various types of structural problem.

In making such applications it is necessary, of course, to be able to assign "dimensions" to all quantities concerned. An angle is commonly regarded as a dimensionless quantity, radian measure being obtained by dividing length by length. The significance of "dimensionless" here is merely that radian measure does not change when the length unit is changed. But "angle" is not dimensionless: it changes to degrees or revolutions are contemplated, and such changes should, of course, be considered if anything can be deduced therefrom. This is sometimes the case, as appears later. However, if this is done, the equation relating angular measure θ to arc s and radius r must be written

$$\theta = C \frac{s}{r} \quad (2)$$

where C has the value 1 when the radian is the angular unit, $\frac{180}{\pi}$ when the degree is the unit, and so on.

¹This assumes that the function is single-valued in all its arguments. Stress is not a single-valued function of strain beyond the elastic range, where the curve of rising stress is not the same as the curve of falling stress. Thus, results based on such a relation are not necessarily subject to the present analysis. This is discussed further in sec. 8.

Otherwise any calculation involving such a relation is not valid in all unit systems. The "constant" C is a "dimensional constant" and has the dimension of an angle.

Strain, as inches extension per inch of length, or centimeters per centimeter, and so on, is also commonly treated as dimensionless. It can, however, also be measured in centimeters per inch, or if the use of two length units is objectionable, in any arbitrary unit such as the "microstrain" - 10^{-6} centimeter per centimeter. It is then necessary to write the strain e in terms of extension δ on a length l as

$$e = C \frac{\delta}{l} \quad (3)$$

where C is a dimensional constant, having the same dimension as strain, with the value 1 when strain is measured in the usual manner.

Dimensional constants of this kind, as well as "physical constants," must be included in the list of symbols for any problem the solution of which requires the equation in which they occur, for the final formula will not, in general, be valid in all unit systems unless the equations used in deriving it had this property. Of course, the C of equation (2) usually is not included in dimensional analyses. It usually is fixed as unity by the tacit decision not to consider any change of angle unit from the radian. As will appear in a later section, the omission of the C of equation (3) from an inelastic structural problem, thus preventing the consideration of any change of strain unit, may result in the deduction of unnecessarily restricted similarity conditions.

3. SIMILARITY OF STRUCTURES IN EQUILIBRIUM

Consider first a structure made of homogeneous isotropic material which obeys Hooke's law. Let it be specified in size and shape by a necessary and sufficient set of linear dimensions a, b, c, \dots , and let the loads on it be $P^2, \alpha P, \beta P, \gamma P$, and so forth, where α, β, γ are dimensionless numbers. Young's modulus and Poisson's ratio will be denoted by E and μ .

²The loads are taken as forces. If they are couples (ii) or pressures (p), it is merely necessary to write M/a or pa^2 instead of P wherever P occurs.

These variables define the system. It will be required to determine certain features of its state, usually a force R , such as a redundant reaction, a force in a member, or a stiffener, a stress σ , strain e , or displacement δ . The lengths a, b, c, \dots , will be supposed to contain those necessary to specify the point at which any of these are to be found. Then each of the quantities

$$\left. \begin{array}{l} R \\ \sigma \\ e \\ \delta \end{array} \right\} \begin{array}{l} \text{can be expressed in terms of } P, \alpha, \beta, \gamma \dots, \\ a, b, c \dots, E, \mu \end{array} \quad (4)$$

Let there be n quantities, counting one of the column on the left. There are only two fundamental measuring units involved, since each of the quantities in equation (4) can be measured when, for instance, units of force and length are given. Denoting these units by F and L , the dimensions of the quantities in equation (4) may be written in terms of these units, in order, as

$$\left. \begin{array}{l} F \\ FL^{-2} \\ 0 \\ L \end{array} \right\} F, 0, 0, 0 \dots, L, L, L \dots, FL^{-2}, 0 \quad (5)$$

Since there are two fundamental units $n-2$ dimensionless products from any of the four sets of variables in equation (4) can be formed, according to Buckingham's theorem. It is easily seen by inspection that these may be taken as³

$$\left. \begin{array}{l} R/P \\ \sigma a^2/P \\ e \\ \delta/a \end{array} \right\} \frac{P}{Ea^2}, \alpha, \beta, \gamma \dots, b/a, c/a \dots, \mu \quad (6)$$

³The constitution of the dimensionless groups is not unique. For instance, P/Ea^2 might be replaced by P/P_{cr} or $\frac{Pl^2}{\pi^2 EI}$ for a column problem.

There is one relation between any one of the dimensionless groups in the column, and all the dimensionless groups in the row. Thus it is possible to write

$$\left. \begin{aligned} \frac{R}{P} &= f_1 \left(\frac{P}{Ea^2}, \alpha, \beta, \gamma \text{ --- } \frac{b}{a}, \frac{c}{a} \text{ --- } \mu \right) \\ \frac{\sigma a^2}{P} &= f_2 \left(\frac{P}{Ea^2}, \alpha, \beta, \gamma \text{ --- } \frac{b}{a}, \frac{c}{a} \text{ --- } \mu \right) \\ e &= f_3 \left(\frac{P}{Ea^2}, \alpha, \beta, \gamma \text{ --- } \frac{b}{a}, \frac{c}{a} \text{ --- } \mu \right) \\ \frac{\delta}{a} &= f_4 \left(\frac{P}{Ea^2}, \alpha, \beta, \gamma \text{ --- } \frac{b}{a}, \frac{c}{a} \text{ --- } \mu \right) \end{aligned} \right\} \quad (7)$$

where $f_1()$, $f_2()$, $f_3()$, $f_4()$, represent definite functional forms. These relations in fact stand for the solution of the problem in general form, covering, with invariable functional forms, all systems which can be got by giving particular values to the variables (4), and, of course, covering also all possible systems of measuring units. Thus in particular they cover a structure and its scale model. The conditions of similarity are the conditions that the functions on the right of equations (7) shall have the same numerical value when calculated for the structure as they have when calculated for the model, and the similarity relations are then expressed by the equality of the groups on the left of equations (7) calculated for structure and model.⁴

The functions (supposed single-valued) will have identical values for structure and model if the arguments have identical values. The ratios $\alpha, \beta, \gamma \text{ ---}$ are the same if the several loads of the model bear the same ratios to one another as the several loads of the structure. The ratios $\frac{b}{a}, \frac{c}{a} \text{ ---}$, are the same for a model which is to scale in every significant dimension.⁴

⁴It is often possible to relax these conditions by the use of knowledge of the problem beyond that afforded by dimensional analysis. Examples are given later.

Poisson's ratio μ must be the same (unless as in the case of trusses and rigid frames free of torsional action, it is known to be without influence on the behavior considered). Finally, it is necessary to make

$$\left(\frac{P}{Ea^2}\right)_m = \left(\frac{P}{Ea^2}\right)_s \quad (8)$$

where the subscript m stands for "model" and s for "structure." Thus when the model loads are scaled down according to

$$\frac{P_m}{P_s} = \frac{E_m a_m^2}{E_s a_s^2} \quad (9)$$

it will be true, by equating the left sides of equations (7), that

$$\frac{R_m}{R_s} = \frac{P_m}{P_s}; \quad \frac{\sigma_m}{\sigma_s} = \frac{P_m a_s^2}{P_s a_m^2} = \frac{E_m}{E_s} \quad (\text{by equation (8)});$$

$$\frac{e_m}{e_s} = 1; \quad \frac{\delta_m}{\delta_s} = \frac{a_m}{a_s} \quad (10)$$

These results may be expressed in an alternative way by observing that since, (the other similarity conditions being already fulfilled) if any given value of P/Ea^2 is taken, the corresponding values of R/P , $\sigma a^2/P$, e , δ/a are then the same whether model or structure is considered, the curves of R/P , $\sigma a^2/P$, e , δ/a plotted against P/Ea^2 from measurements on the model, at various loads P_m , are also valid for the structure.

It is evidently permissible to make the model and the structure of different materials, so long as the Poisson's ratios, if these are significant in the problem, are kept the same.

The dimensionless number P/Ea^2 plays a part here which is analogous to that of Reynolds number (or the other characteristic numbers of fluid systems) in fluid

mechanics. It is proposed to call it, or any like quantity, the "strain number."

4. LINEAR AND NONLINEAR STRUCTURES

The foregoing results are not restricted, as most of the calculations of structural theory are, to small displacements. They cover flexible structures, such as very thin rings, or very slender beams and columns, where the deflections are too large to have a linear relation to the loads, although the strain components themselves are small and the stress-strain relations are linear. The departure from linearity arises from the changing shape of the structure as it is loaded. There are also structures in which the displacements, though small, significantly affect the action (e.g., the moment arms) of the loads, as in the beam under simultaneous lateral load and axial thrust - the "beam-column," or the elastic cable, initially just taut, under lateral load, which has a displacement proportional to the cube root of the load at first. All such cases are grouped under the "nonlinear" designation.

On the other hand, there is the extensive linear group, where the displacements are linear functions of the loads, and the method of superposition is valid. This group, of course, includes the majority of stress problems. When this linearity can be assumed, it can be said that redundant reactions (unless the support is of a peculiar kind, such as a nonlinear spring), stresses, strains, and displacements will all be proportional to the load - that is, to P .

Reconsidering equations (7) will lead then to the requirement that R/P is to be independent of P , and this requires that the function f_1 should be independent of the group P/Ea^2 , or

$$R/P = f_1 \left(\alpha, \beta, \gamma \text{ ---}, \frac{b}{a}, \frac{c}{a} \text{ --- } \mu \right) \quad (11)$$

Since Young's modulus does not appear in any other group, it follows that R is independent of it; R may, however, still depend on Poisson's ratio,

Usually, in the linear type of structure, σ , e and

δ will be proportional to P , so that instead of the last three of equations (7) the following equations may be written:

$$\left. \begin{aligned} \frac{\sigma a^2}{P} &= f_2 \left(\alpha, \beta, \gamma \text{ --- } \frac{b}{a}, \frac{c}{a} \text{ --- } \mu \right) \\ e &= \frac{P}{Ea^2} f_3 \left(\alpha, \beta, \gamma \text{ --- } \frac{b}{a}, \frac{c}{a} \text{ --- } \mu \right) \\ \frac{\delta}{a} &= \frac{P}{Ea^2} f_4 \left(\alpha, \beta, \gamma \text{ --- } \frac{b}{a}, \frac{c}{a} \text{ --- } \mu \right) \end{aligned} \right\} \quad (12)$$

The conditions of similarity are now merely the obvious ones of geometrical similarity and similar distribution of loads (α, β, γ the same for structure and model), and equal Poisson's ratio if this is of significance in the problem. With these fulfilled,

$$R = K_1 P, \quad \sigma = K_2 \frac{P}{a^2}, \quad e = K_3 \frac{P}{Ea^2}, \quad \delta = K_4 \frac{P}{Ea} \quad (13)$$

where K_1, K_2, K_3, K_4 are constants, the same for both structure and model. Thus in linear structures one measurement of each kind, at a single load, on the model is in principle all that is necessary for the complete analysis of the structure.

Alternatively it may be said that if the curves of $R/P, \sigma a^2/P, e, \delta/a$ against P/Ea^2 are plotted from measurements on the model, the first two will be straight lines parallel to the P/Ea^2 axis and the last two will be straight lines through the origin, and the diagrams will be equally valid for the structure.

When the load includes the weight of the structure itself, represented by a specific weight w , a further dimensionless group, for instance $\frac{wa}{E}$, must be introduced. It is then convenient to replace the first two groups in the column on the left of equation (6) by $\frac{R}{Ea^2}, \frac{\sigma}{E}$, which gives, in general,

$$\left. \begin{array}{l} \frac{R}{Ea^2} \\ \frac{c}{E} \\ e \\ \frac{\delta}{a} \end{array} \right\} = \begin{array}{l} f_1 \left(\frac{P}{Ea^2}, \frac{wa}{E}, \alpha, \beta, \gamma, \frac{b}{a}, \frac{c}{a}, \mu \right) \\ f_2 \left(\right) \\ f_3 \left(\right) \\ f_4 \left(\right) \end{array} \quad (14)$$

But if the structure is a "solid" one, such as a dam (reference 3), having small deformations which do not affect the action of the loads, it will be linear both as to P and w , and the problem divides itself into two, one to determine the effects of the gravity loading only, the other to determine the effects of surface loading only. In the dam problem the surface loading would be water pressures, which can be described by a maximum pressure p , together with dimensionless ratios to describe the distribution of pressure. These may be omitted. Then instead of P/Ea^2 , p/E may be used. Consider, in particular, the stress σ , which represents any chosen component at any particular point. Since this is to be linear in both w and p , it is necessary that

$$\frac{\sigma}{E} = \frac{wa}{E} f_2 \left(\frac{b}{a}, \frac{c}{a}, \mu \right) + \frac{p}{E} F_2 \left(\frac{b}{a}, \frac{c}{a}, \mu \right) \quad (15)$$

The E now cancels, and it follows that the stress is independent of E , but depends on μ . A model should have the same Poisson's ratio, if it is significant, and must be geometrically similar. The functions f_2 and F_2 then have the same value for both model and structure, and may be replaced by constants c_1 and c_2 , so that

$$\sigma = c_1 wa + c_2 p \quad (16)$$

The two parts may be determined by separate tests, using model material of any convenient density, or producing w centrifugally, (or replacing the body force problem by a surface load problem (reference 4)).

Different models, of different materials may be used for the two tests, so long as μ is kept the same. The object of the model tests may be regarded as the determination of c_1 and c_2 . It is evidently not necessary to put any restrictions on the manner by which the pressure p on the model is created, although at first sight, if the system is taken as a single fluid-solid system, it might appear that the specific weight of the fluid should be included in the list of variables, and then that a fluid of a suitably different density must be used. Of course, a change from the dimensionless relation (equation (15)) to the dimensional form (equation (16)) implies that the same measuring units will be used for both structure and model.

In many cases it will be obvious that the condition of strict geometrical similarity may be dispensed with without loss of exactness. In simple trusses only the areas, not the individual dimensions, of cross sections are significant. When there is simple bending, the proper moment of inertia, and for torsion, the proper torsional rigidity, may be provided without regard to shape. Here, of course, knowledge obtained from detailed analyses of bars as structural elements is employed. Considerations of this kind underlie Theodorsen's discussion of similarity of propellers (reference 5) (as to vibrational frequencies) obtained by lengthening in one proportion and changing cross-sectional dimensions in another, for the differential equation of free flexural vibration of a bar may be written

$$\frac{\partial^2}{\partial x^2} \left(EI \frac{\partial^2 y}{\partial x^2} \right) + \rho A \frac{\partial^2 y}{\partial t^2} = 0$$

where ρ is the density, EI the flexural rigidity, and A the area of cross section, as functions of x . The process of solving this for the nonuniform bar to find the deflection y as a function of the axial coordinate x , and determining the fundamental frequency, can be readily envisioned, even if not easily carried out, by anyone familiar with the process for the uniform bar.

Let I be written as $A_0 k_0^2 f_1 \left(\frac{x}{l} \right)$ and A as $A_0 f_2 \left(\frac{x}{l} \right)$ where A_0 , k_0 are the area and radius of gyration of the base section, and l the length, $f_1 f_2$

being given functions, involving only dimensionless - that is, invariable, - parameters. Then the equation can be written

$$\frac{\partial^2}{\partial x^2} \left[f_1 \left(\frac{x}{l} \right) \frac{\partial^2 y}{\partial x^2} \right] + \frac{\rho}{E k_0^2} f_2 \left(\frac{x}{l} \right) \frac{\partial^2 y}{\partial t^2} = 0$$

The frequency will then depend on the quantities $\frac{\rho}{E k_0^2}$ and l , and on no other quantities. There is only one dimensionless combination of these quantities and the frequency f . It is the left member of

$$\frac{f l^2}{k_0} \sqrt{\frac{\rho}{E}} = C$$

(or any power of it) and this equation must hold with C a constant (for a given mode) for all systems expressible by means of l , k_0 , ρ , E , $f_1\left(\frac{x}{l}\right)$, and $f_2\left(\frac{x}{l}\right)$. Since f_1 and f_2 are invariable functional forms, the ratios of the l 's and the ratios of the A 's for corresponding sections (x/l the same) must be the same for all the systems. But there is no restriction to any particular shape of cross section, as by the proportional enlargement of all dimensions of the cross section.

Without the auxiliary information contained in the differential equation other dimensionless arguments, such as l/k_0 would have appeared, and the conclusions would have been more restrictive.

Dimensional analysis alone gives a basic form of similarity. Further knowledge may give more general forms. It is a matter of obtaining the most detailed formula possible - and there is at least that yielded by dimensional analysis - and considering what is the broadest class of systems to which it applies. The members of this class are then "similar" on the basis of the formula considered.

5. COMPOSITE STRUCTURE

If the structure is not all of the same material, it will be necessary to include in the row of independent variables in equation (4) the several Young's moduli and Poisson's ratios. Let these be E, E_1, E_2 ---, and so forth, and μ, μ_1, μ_2 ---. Then to the row of dimensionless groups in (6) must be added $E_1/E, E_2/E$ ---, and so forth, and μ_1, μ_2 ---, and the same additions must be made to the arguments of the functions in equations (7). The conditions of similarity now include the identity of $E_1/E, E_2/E$ ---, μ_1, μ_2 --- for structure and model. The similarity relations (equation (10)) then remain valid for the nonlinear type of structure, when the strain numbers P/Ea^2 are made the same for model and structure. Correspondingly, the treatment of the linear structure is modified merely by the addition of the requirement of identity of $E_1/E, E_2/E$ ---, μ_1, μ_2 ---, in both model and structure, to the set of similarity conditions.

6. PRESCRIBED DISPLACEMENTS

So far, the problem has been considered as one in which the loads are all given, and it is required to find reactions, stress, strain, and displacement. Consider now given displacements, not necessarily small, the problem being to determine these same four quantities. Instead of the variables in (4) there are now

$$\left. \begin{array}{l} R \\ \sigma \\ e \\ \delta \end{array} \right\} \begin{array}{l} \text{depending on } U, \alpha', \beta', \gamma' \text{ ---,} \\ a, b, c \text{ --- } E, \mu \text{ ---} \end{array} \quad (17)$$

where the prescribed displacements are $U, \alpha'U, \beta'U, \gamma'U$, and so forth. Again the number of dimensionless groups must be two less than the number of variables in (17), counting only one of the column on the left. It is evident that they may be taken as

$$\left. \begin{array}{l} R/Ea^2 \\ \sigma/E \\ e \\ \delta/a \end{array} \right\} \left(\frac{U}{a}, \alpha', \beta', \gamma' \dots, \frac{b}{a}, \frac{c}{a} \dots, \mu \right) \quad (18)$$

and it is necessary to have

$$\left. \begin{array}{l} R/Ea^2 = f_1 \left(\frac{U}{a}, \alpha', \beta', \gamma' \dots, \frac{b}{a}, \frac{c}{a} \dots, \mu, \dots \right) \\ \sigma/E = f_2 \left(\dots \right) \\ e = f_3 \left(\dots \right) \\ \delta/a = f_4 \left(\dots \right) \end{array} \right\} \quad (19)$$

The similarity conditions now include identity of μ for model and structure, if it is significant, and also

$\frac{U_m}{a_m} = \frac{U_s}{a_s}$ - that is, the imposed displacements must be to scale. The similarity relations are then

$$\frac{R_m}{R_s} = \frac{E_m a_m^2}{E_s a_s^2}, \quad \frac{\sigma_m}{\sigma_s} = \frac{E_m}{E_s}, \quad \frac{e_m}{e_s} = 1, \quad \frac{\delta_m}{\delta_s} = \frac{a_m}{a_s},$$

and, alternatively, curves of R/Ea^2 , σ/E , e , u/a against U/a obtained from the model by varying U_m are also valid for the structure.

It may be observed that E does not appear at all in the last two of equations (19). There is no other quantity containing the force unit with which it can be combined to give a dimensionless group. It follows then that the distributions of strain and displacement are independent of the Young's modulus. This is evident from the well-known differential equations of Lamé for the special case of the linear structure, but perhaps not so evident for the nonlinear structure.

In the case of the linear structure R , σ , e , and δ are proportional to U . Hence equations (19) must take the form

$$\left. \begin{aligned} R/Ea^2 &= \frac{U}{a} f_1 \left(\alpha', \beta', \gamma' \text{ --- } \frac{b}{a}, \frac{c}{a} \text{ --- } \mu \text{ ---} \right) \\ \sigma/E &= \frac{U}{a} f_2 \left(\right) \\ e &= \frac{U}{a} f_3 \left(\right) \\ \delta/a &= \frac{U}{a} f_4 \left(\right) \end{aligned} \right\} (20)$$

or $R = K_1 aU$, $\sigma = K_2 E \frac{U}{a}$, $e = K_3 \frac{U}{a}$, $\delta = K_4 U$, valid for both model and structure where K_1 , K_2 , K_3 , and K_4 are constants, the same for both model and structure.

The additional arguments, E_1/E , E_2/E , and so forth, and μ_1 , μ_2 , and so forth, will be required in the functions of equations (20) when the structure is composite, and the additional similarity conditions are as before.

7. MIXED CONDITIONS

When there are prescribed loads at some points, prescribed displacements (nonzero) at others, the set of variables consists of (4) and (17) combined, and the general relations can be taken in the form

$$\left. \begin{aligned} \frac{R}{P} &= f_1 \left(\frac{P}{Ea^2}, \alpha, \beta, \gamma \text{ --- } \frac{U}{a}, \alpha', \beta', \gamma' \text{ --- } \frac{b}{a}, \frac{c}{a} \text{ --- } \mu \text{ ---} \right) \\ \frac{\sigma_{ax}}{P} &= f_2 \left(\right) \\ e &= f_3 \left(\right) \\ \frac{\delta}{a} &= f_4 \left(\right) \end{aligned} \right\} (21)$$

The similarity conditions are now geometrical similarity (b/a , c/a , etc., the same for structure and model), similar distribution of loads and prescribed displacements (α , β , γ --- α' , β' , γ' --- the same), identity of the Poisson's ratios if significant, and also

$$\frac{P_m}{E_m a_m^2} = \frac{P_s}{E_s a_s^2}, \quad \frac{U_m}{a_m} = \frac{U_s}{a_s} \quad (22)$$

These being fulfilled, the similarity relations (equations (10)) will again hold. The surfaces of R/P , $\sigma a^2/P$, e , δ/a plotted against P/Ea^2 and U/a , determined from the model, are also valid for the structure.

8. CURVED STRESS-STRAIN RELATIONS

LOADING BEYOND THE PROPORTIONAL

AND ELASTIC LIMITS

If the ordinary tensile or compressive stress-strain diagram of the material of the structure is curved, it is customary to retain the term "Young's Modulus," for the slope of the curve. It is no longer a constant but a function of the stress or the strain. The strain number P/Ea^2 now ceases to have any definite value characteristic of the whole structure and its load. Buckingham's theorem cannot be applied unless definite numerical values can, at least in principle, be given to all the variables involved, and it does not necessarily hold unless there is just one relation between these variables. (See reference 2.) In the set (4), with σ on the left, there would be a relation between σ and E as well as the relation between all the symbols which is the required formula for σ .

In order to overcome these difficulties, it is appropriate to reconsider the whole process of determining stress-strain relations experimentally, putting them in a form valid in all unit systems, and combining them with the equations of compatibility and equilibrium, and the boundary conditions, necessary for the solution of the problem. It is the stress-strain relations which require particular attention, no special measures being required to put the other equations in a form valid for all unit systems. In an experimental determination the stress and

strain will be recorded in definite units, and the six components of stress σ_1 , σ_2 , and so forth, will be found as functions of the six components of strain (not necessarily small) e_1 , e_2 , and so forth, say⁵

$$\sigma_1 = \phi_1(e_1, e_2 \text{ ---}), \sigma_2 = \phi_2(e_1, e_2 \text{ ---}) \text{ etc.} \quad (23)$$

These relations involve only specific numbers q besides the σ and e symbols, and they are, of course, true only in the units selected.

Consider now the relations

$$\frac{\sigma_1}{E_1} = \phi_1\left(\frac{e_1}{\epsilon_{11}}, \frac{e_2}{\epsilon_{12}}, \text{ ---}\right), \frac{\sigma_2}{E_2} = \phi_2\left(\frac{e_1}{\epsilon_{21}}, \frac{e_2}{\epsilon_{22}}, \text{ ---}\right) \text{ etc.} \quad (24)$$

where E_1 , E_2 ---, and the ϵ 's are as yet merely arbitrary parameters. When they are given the value 1, the relations (equations (24)) become identical with equations (23). They are now assigned the value 1 in the experimental unit system. Let E_1 , E_2 be assigned the dimensions of stress (i.e., their values in new unit systems are defined to be those obtained by applying the conversion factors appropriate to stress) and let the ϵ 's be assigned the dimensions of strain (as discussed in sec. 2). Then equations (24) are stress-strain relations of the material valid in all unit systems. For they are true in the original unit system. In a changed unit system the E 's change by the same factor as the σ 's and the e 's by the same factor as the ϵ 's, so that the ratios σ/E and e/ϵ remain the same, and the equations remain valid. The numbers q involved in the functional forms ϕ are, of course, not changed when the unit system is changed. That is, they are dimensionless numbers.

The problem of determining a stress component σ in a structure with loads P , αP , βP , and so forth, and linear dimensions a , b , c --- now involves (as dimensional constants) the E 's and ϵ 's, the list being

$$\sigma, P, \alpha, \beta \text{ ---}, a, b, c \text{ ---}, E_1, E_2, E_3, \text{ ---}, \epsilon_{11}, \epsilon_{12}, \epsilon_{22} \text{ ---} \quad (25)$$

Symbols E_i , ϵ_{ij} , $i = 1, \text{ --- } 6$, $j = 1, \text{ --- } 6$ have been added and one additional fundamental unit (that of strain) is admitted.

⁵Creep, effects of rate of strain, etc. are not taken into account.

There are consequently three fewer arguments than symbols, and they may be taken as those appearing in the functional relation

$$\frac{\sigma a^2}{P} = f\left(\frac{P}{E_1 a^2}, \alpha, \beta \text{ ---}, \frac{b}{a}, \frac{c}{a} \text{ ---}, \frac{E_2}{E_1}, \frac{E_3}{E_1} \text{ ---}, \frac{\epsilon_{12}}{\epsilon_{11}}, \frac{\epsilon_{22}}{\epsilon_{11}} \text{ ---}\right) \quad (26)$$

This is the form the stress formula must take to be valid in all unit systems, when the material has the stress-strain relations (23) in the original unit system and the E 's and ϵ 's are defined as above.

It is necessary now to redefine the E 's and ϵ 's, allowing them to assume any values in the original unit system. Then equations (24) define a family of stress-strain laws. The E 's and ϵ 's may change on account of a change of unit system, or on account of a change to another material. The general problem is now to find a stress formula to cover all systems obtainable by varying the symbols in (25) (omitting σ as the dependent variable). The dimensional analysis of this problem results in equation (26) again. Let there be a structure with definite values (in the original units) of all the symbols, including the E 's and ϵ 's, which are, of course, determined by the material used. A model then may be constructed of a different material belonging to the family (equations (24)). To be able to interpret its behavior in the absence of further knowledge, it will be necessary to make all the arguments on the right of equation (26) the same as for the prototype. This again, of course, leads to geometrical similarity, similarity of load distribution, equality of the strain numbers $P/E_1 a^2$, but also

$$\left(\frac{E_2}{E_1}\right)_m = \left(\frac{E_2}{E_1}\right)_s, \left(\frac{E_3}{E_1}\right)_m = \left(\frac{E_3}{E_1}\right)_s, \left(\frac{\epsilon_{12}}{\epsilon_{11}}\right)_m = \left(\frac{\epsilon_{12}}{\epsilon_{11}}\right)_s, \left(\frac{\epsilon_{22}}{\epsilon_{11}}\right)_m = \left(\frac{\epsilon_{22}}{\epsilon_{11}}\right)_s, \text{ etc.} \quad (27)$$

That is, the E 's of the model material must be those of the structure material multiplied by some number λ , and the ϵ 's similarly with an independent factor μ .⁶ Thus if the stress-strain relations of the structure material are

$$\sigma_1 = \Phi_1 (e_1, e_2, \text{ ---}), \quad \sigma_2 = \Phi_2 (e_1, e_2, \text{ ---}), \text{ etc.} \quad (28)$$

⁶Not Poisson's ratio.

in a definite unit system, those of the model material must be

$$\frac{\sigma_1}{\lambda} = \Phi_1 \left(\frac{e_1}{\mu}, \frac{e_2}{\mu}, \dots \right), \quad \frac{\sigma_2}{\lambda} = \Phi_2 \left(\frac{e_1}{\mu}, \frac{e_2}{\mu}, \dots \right), \text{ etc.} \quad (29)$$

These may be described as obtained by an affine transformation from the former. In a two-dimensional problem where the variables are limited to those explicitly shown in equations (29) (except for a third relation, such as that of incompressibility, yielding a third strain component in terms of e_1, e_2), σ_1 in equations (28) could be represented as a surface over an e_1, e_2 plane. Then the σ_1 surface in equation (29) is obtained by deforming this surface by uniform extension in the σ_1 direction by the proportion λ , and uniform extension in the e_1, e_2 directions by the proportion μ . The scales of σ_1, e_1, e_2 remain undeformed. The σ_2 surface is treated similarly. In one dimension the stress-strain curve (equation (29)) may be imagined obtained by drawing that of the structure material (equation (28)) on a rubber sheet, on which is placed a rigid axis frame bearing the rigid scales, then stretching the rubber sheet under the frame to μ times its original length parallel to the strain axes, λ times its original length parallel to the stress axis. The factors λ and μ may, of course, be arbitrarily chosen. There is thus no necessity to make a model of the same material as the structure, even when curved stress-strain relations, elastic or plastic, are involved. But, in the plastic case, the functions Φ in equations (28) are not, in general, single-valued, and, as pointed out in section 2, the dimensional analysis does not then necessarily hold. However, the functions become single-valued if a definite mode of loading and unloading is prescribed. Thus the values of $P/E_1 a^2$ for the model must go through the same values in the same order as the values of $P/E_1 a^2$ for the structure, for the above similarity rules to apply.

When the same material is used in both model and structure, the ratios E_2/E_1 , and so forth, e_{12}/e_{11} , and so forth, in equation (26) are all unity. Similarity then requires, besides geometric similarity ($b/a, c/a \dots$)

and similar distribution of load (α, β ---), equality of the strain numbers $P/E_1 a^2$. Since the use of the same units for both model and structure is now contemplated, this means equality of P/a^2 . It then follows from equation (26) that $\sigma a^2/P$ is the same for both - for example, stresses at corresponding points are equal.

The arguments of this section may easily be extended to cover problems other than those of prescribed loads, such as those of prescribed displacements, or "mixed" problems, which have been discussed in preceding sections for the ideal elastic material only. The modifications of the preceding treatments are merely that E_1 replaces E , in strain numbers P/Ea^2 , or R/Ea^2 and the affine connection must hold between the stress-strain relations of model and structure material.

It will be observed that the numerical value of E_1 in equations (24) can be chosen at will in a given unit system. Different choices will result in compensating differences in the numerical coefficients. Once E_1 has been chosen in the selected system, however, its value is fixed in all other unit systems since it has the dimensionality of stress. It will sometimes be convenient to choose E_1 as the elastic Young's modulus of the material, for the sake of continuity with the elastic range in plotting.

An example of a problem of nonlinear stress-strain relations is provided by rubber springs, the rubber being attached to steel mountings which may be regarded as undeformable. This, as a problem of given load, is one involving two materials, steel and rubber, but no symbols need be introduced for the properties of the steel, since it is rigid. The preceding theory shows that a simple similarity relation can exist when the same materials are used for two such springs which are geometrically similar. In particular, when the same rubber is used in two geometrically similar springs the curve of U/a against P/a^2 is the same for both, the same units being used. Curves of this type have been published. (See reference 6.) The present discussion shows that they contain no "size effect."

An example of similarity in the plastic range is afforded by the simple tensile test. The similarity of the deformed shapes and the identity of the stress-strain

curves, for specimens geometrically similar but of different sizes, has been experimentally confirmed, and is known as Barba's law. (See, for instance, reference 7.) The dimensional analysis made shows that such similarity exists generally (the stress depending only on the strain).

It is of interest to compare the deformed shapes of two test pieces, or other structures, of the same size but of two different materials with affinely related stress-strain laws (equations (28) and (29)). A displacement formula must correspond to equation (26) with δ/a on the left instead of $\sigma a^2/P$. Then the values of δ/a for the two pieces are the same - that is, their deformed shapes are the same - when their values of $P/E_1 a^2$ are the same. If the pieces are of different sizes and geometrically similar in the undeformed state, they are also geometrically similar in the deformed state at equal values of $P/E_1 a^2$.

Nadai (reference 8) quotes as an example of similarity in elastic-plastic systems, which, of course, are included in the theory of this section as well as fully plastic systems, the case of a series of balls indenting blocks. If the material is the same for all the balls and for all the blocks, and if the loads are as the squares of the ball diameters, the stresses will be the same at corresponding points and the depths of the indentations and the diameters of the plastic zones on the block surface will be as the diameters of the balls, provided the effects of time of loading are negligible. A time variable could be included in the dimensional analysis and the similarity conditions correspondingly extended.

9. BUCKLING

Returning to the problem of prescribed loads of sections 2 and 7, in order to consider questions of stability, it is appropriate to review the several types of buckling which are now recognized. There is the idealized buckling of geometrically perfect struts, illustrated by the load deflection curve of figure 1(a), where no deflection at all occurs until the critical load is reached at A, and above the critical load there is an unstable straight form B and a stable deflected form C. Secondly, there is actual buckling of a geometrically imperfect strut, of a

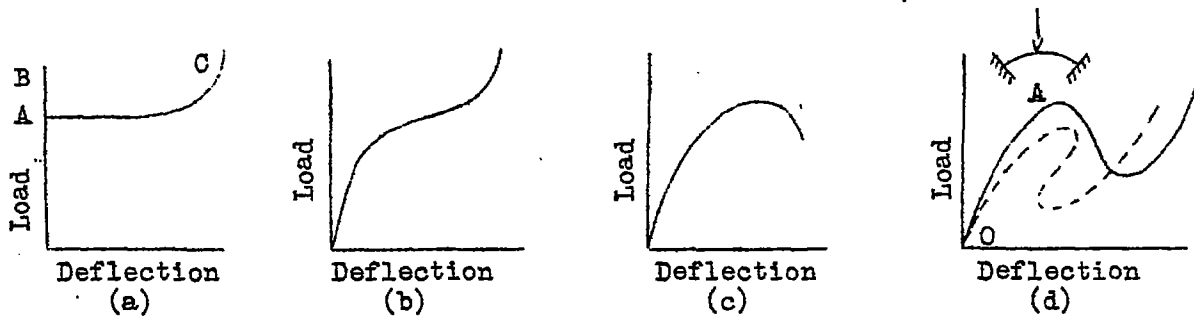


Figure 1.

slenderness such that there is no failure of proportionality until well beyond buckling. This behavior is illustrated by figure 1(b). There is a unique deflection at each load, and no instability in the sense of figure 1(a). The sense of "buckling" here is, of course, the inordinately rapid increase of deflection when the load is in the neighborhood of the Euler critical value.

Thirdly, there is buckling after the proportional limit has been exceeded (see, for instance, reference 9), characterized by the type of load deflection curve shown in figure 1(c). Here there is true mechanical instability at and beyond the maximum load point, and this maximum load is the critical load.

Finally, there is buckling of the snap-over, or "oil-canning," type of which the kinds of curve shown in figure 1(d) are characteristic. The sketch in figure 1(d) of a slightly curved bar or plate with rigid or stiff end or edge constraints and a transverse load illustrates one way of realizing such a curve. (See reference 10.) It appears that the buckling of shells may belong to this type rather than to that of figure 1(a) or 1(b). Points on the rising part of the curve OA represent stable forms, but there are alternative forms at larger deflections, to which the system may jump when assisted over the peak by a suitable impulse. (See reference 11.)

Instead of load-deflection curves (P against δ)

$\frac{P}{Ea^2}$ may be plotted against $\frac{\delta}{a}$, regarding them as examples of the $\frac{\delta}{a}$ against $\frac{P}{Ea^2}$ curve discussed in section

3. These curves are then valid for both a model and its prototype. However the critical load in figures 1(a), 1(b), 1(c), and 1(d) may be defined, it will be done by singling out a particular point of this curve, and this point will characterize the buckling for both model and structure. Thus buckling will be characterized by a definite strain number P/Ea^2 whether the displacements concerned can be regarded as small or not. This is evidently analogous to the characterization of turbulence by a definite Reynolds number. The critical loads P_{mcr} and P_{scr} of model and structure are related by

$$\frac{P_{mcr}}{P_{scr}} = \frac{E_m a_m^2}{E_s a_s^2}$$

Where curved stress-strain relations, elastic or inelastic, must be considered, the discussion in section 8 permits making the same statement about the strain number $P/E_1 a^2$. If model and structure are of the same material

$$\frac{P_{mcr}}{a_m^2} = \frac{P_{scr}}{a_s^2}$$

(the same units being used for both) and the critical stresses are the same whether the buckling is within the elastic range or not.

II. TESTS ON BUCKLED THIN SQUARE PLATES IN SHEAR, WITH AND WITHOUT HOLES

SUMMARY

In order to test the validity of similarity principles for structures involving buckling and plastic flow, measurements of strains and displacements were made, at Cornell University, on square thin sheets in shear, with and without holes. With certain exceptions, the measurements follow closely the indications of the similarity principles. The results are shown in figures 5 to 12,

which are dimensionless plots of the measurements. For similarity the points in each figure should fall on a single curve.

10. THE TEST PROGRAM

It appears from the engineering literature that the possibility of drawing such conclusions as those of part I is frequently overlooked, and that unnecessarily elaborate and expensive model testing has been carried out in recent years. Similarity in the plastic range is well known to some, but others have denied the possibility of it on the grounds that the physical constants required for the specification of plastic behavior in metals are not defined. Barba's investigation of similarity in the tensile test has been referred to in section 8. No record has been found of investigations of similarity in plastic bending or torsion, but in view of the dimensional analysis of section 8 there can be little doubt that it would be found to exist. No tests of this kind were therefore included in the program.

The aircraft problems of chief interest are those of thin-walled structures. The difficulty of making satisfactory thin-walled models has been emphasized by Saunders and Windenburg (reference 12), and others. The wall thicknesses in the prototype being already small, those of a small model will be very small, and lack of flatness of the sheets becomes proportionately more important.

11. TEST SPECIMEN AND QUANTITIES TO BE MEASURED

The structure chosen for the tests was the square panel of thin sheet 24S-T aluminum alloy confined in a hinged frame of "rigid" bars (heavy angle irons were employed) and subjected to shear, as indicated diagrammatically by figure 2. Specimens with and without central lightening holes were tested. Three sizes of frame (designed as nearly as possible to be geometrically similar - see fig. 3, table I), two sizes of hole, and five thicknesses of sheet were used. This structure presents certain of the fundamental problems of the thin web beam - the strength of the panel and its mode of wrinkling, which are important in themselves - and affords a

convenient trial of the possibility of making reliable small scale tests when thin flat sheets are involved. As treated here, it is essentially a problem of large displacements going beyond the elastic limit.

Taking the bars of the hinged frame as rigid, the problem involves deflections (δ), stresses (σ), and strains (e), in a plate defined by the following quantities:

The side of the square (a) (inside dimension of angle frame)

The thickness of the sheet (t)

The diameter of the central hole (D)

under a "shearing load" P (fig. 2).

The dimensional analysis then indicates relations of the form

$$\frac{\delta}{a} = f_1 \left(\frac{P}{Ea^2}, \frac{t}{a}, \frac{D}{a}, \mu \right)$$

$$\frac{\sigma}{E} = f_2 \left(\frac{P}{Ea^2}, \frac{t}{a}, \frac{D}{a}, \mu \right)$$

$$e = f_3 \left(\frac{P}{Ea^2}, \frac{t}{a}, \frac{D}{a}, \mu \right)$$

where E is a dimensional constant as defined in section 8 if there is plastic deformation, or a curved stress-strain relation, or merely Young's modulus below the elastic limit. In any case, when the model is of the same material as the prototype, the curves of $\frac{\delta}{a}$ against $\frac{P}{a^2}$, of σ against $\frac{P}{a^2}$, and of e against $\frac{P}{a^2}$ are the same for all panels in which $\frac{t}{a}$, $\frac{D}{a}$ are the same. For this investigation, Young's modulus of 10.5×10^6 was used for

E , and all curves were plotted against $\frac{P}{Ea^2}$. Since the strain, not the stress, can be measured directly, the test curves are of $\frac{\delta}{a}$ and e .

The measurements of the panels proposed for the tests are shown in table II. The entries connected by broken lines are groups with the same values of both t/a and D/a , but represent panels of different size. The choice of these was governed by the available thicknesses of sheet. Similarity is established if points of all members of each group fall on the same dimensionless curve.

TABLE I (See fig. 3)

FRAME DIMENSIONS

Dimensions	Large frame	Medium frame	Small frame
a	28"	17.4"	8.75"
b	31.5"	19.58"	9.81"
c	36.0"	22.4"	11.25"
d	1 $\frac{1}{4}$ "	3/4"	3/8"
e	$\frac{1}{8}$ "	3/8"	3/16"
f	3 $\frac{1}{2}$ "	2.0"	1 $\frac{3}{16}$ "
g	4 x 3 $\frac{1}{3}$ x $\frac{1}{2}$	2 $\frac{1}{2}$ x 2 x 5/16	1 $\frac{1}{4}$ x 1 $\frac{1}{2}$ x 3/16

12. EXPERIMENTAL PROCEDURE AND APPARATUS

The hinged frame holding the plate was supported laterally and loaded by means of a hydraulic jack. (See fig. 2.) The deflection δ was measured across the long

diagonal by means of a dial gage, this measurement being independent of any rotation of the supporting wall.

The strain measurements were made with the SR-4 type A-1 Baldwin Southwark electrical strain gages. The gages were connected in the dummy-gage temperature-compensated bridge circuit shown in figures 4 and 25. The bridge sensitivity was 0.000026 inch per inch per millimeter on a graduated slide wire for null balance of the bridge.

In plates without holes, the electric strain gages were placed along the center line of the diagonal tension fold, which appeared at approximately 42° with the horizontal sides. Two of the gages were placed in a direction perpendicular to this line, one on each side of the sheet, so as to measure the bending and direct compression. In plates with holes, the gages were placed at the edge of the hole at the positions of maximum bending and maximum tension. These positions can be seen in the photographs of the test specimens (figs. 26 to 40).

In addition to the preceding measurements, the maximum amount of lateral buckling y was measured from the initial plane of the plate. This appeared at the middle of the center diagonal tension fold for specimen without holes, and at the edge of the hole along a line approximately 42° with the horizontal sides for specimen with holes.

13. TEST RESULTS

Measurements of the specimens tested are given in table III. Because of the variation in actual sheet thickness from values contemplated, it was not always possible to obtain exact duplication of numbers given in table II.

Four sets of curves were drawn for each similarity group. (See figures 5 to 12.) They are:

Curve (a)	Tensile strain	e_t	against	P/Ea^2
Curve (b)	Bending strain	e_b	against	P/Ea^2
Curve (c)	Diagonal displacement	δ/a	against	P/Ea^2
Curve (d)	Lateral displacement	y/a	against	P/Ea^2

The direct compressive strain in each case was found to be quite small and was therefore not plotted. The following symbols were used in drawing the curves.

Δ values for small frame

X values for medium size frame

o values for large frame

Figures 13 to 24 represent a summary of the average curves grouped in such a way to show the variations due to different values of t/a and D/a .

Photographs of the specimens are shown in figures 25 to 42. Tabulated data for the curves are given in the appendix.

TABLE II.- PROPOSED TEST SPECIMENS

Similarity group	$\frac{D}{a}$	t	36" frame	22.4" frame	11.25" frame
			a = 28.0"	a = 17.4"	a = 8.75"
			$\frac{t}{a} \times 10^5$	$\frac{t}{a} \times 10^5$	$\frac{t}{a} \times 10^5$
I	0	0.064	228	368	
	0	.051	182		
	0	.040		230	
	0	.032	114	184	366
	0	.020		115	229
II	0.428	0.064	228	368	
	.428	.051	182		
	.428	.040		230	
	.428	.032		184	366
	.428	.020			229
III	0.643	0.064	228		
	.643	.040		230	
	.643	.020			229

(Key to Curves, Figs. 5 to 24)

Group	$\frac{D}{a}$	$\frac{t}{a} \times 10^5$	Tensile strain	Bending strain	Diagonal displacement	Lateral displacement
I	0	364	Fig. 5 (a)	(b)	(c)	(d)
	0	238	Fig. 6 (a)	(b)	(c)	(d)
	0	183	Fig. 7 (a)	(b)	(c)	(d)
	0	117	Fig. 8 (a)	(b)	(c)	(d)
II	0.428	364	Fig. 9 (a)	(b)	(c)	(d)
	.428	229	Fig. 10 (a)	(b)	(c)	(d)
	.428	182	Fig. 11 (a)	(b)	(c)	(d)
III	0.643	228	Fig. 12 (a)	(b)	(c)	(d)

SUMMARY CURVES

Group	$\frac{D}{a}$	Figure	Ordinate	Abscissa	Parameter
I	0	13	$\frac{P}{a^2 E}$	e_T	$\frac{t}{a}$
	0	14	$\frac{P}{a^2 E}$	e_b	$\frac{t}{a}$
	0	15	$\frac{P}{a^2 E}$	δ/a	$\frac{t}{a}$
	0	16	$\frac{P}{a^2 E}$	y/a	$\frac{t}{a}$
II	0.428	17	$\frac{P}{a^2 E}$	e_T	$\frac{t}{a}$
	.428	18	$\frac{P}{a^2 E}$	e_b	$\frac{t}{a}$
	.428	19	$\frac{P}{a^2 E}$	δ/a	$\frac{t}{a}$
	.428	20	$\frac{P}{a^2 E}$	y/a	$\frac{t}{a}$
I II III	$\frac{t}{a}$	21	$\frac{P}{a^2 E}$	e_T	$\frac{D}{a}$
	230	22	$\frac{P}{a^2 E}$	e_b	$\frac{D}{a}$
	230	23	$\frac{P}{a^2 E}$	δ/a	$\frac{D}{a}$
	230	24	$\frac{P}{a^2 E}$	y/a	$\frac{D}{a}$

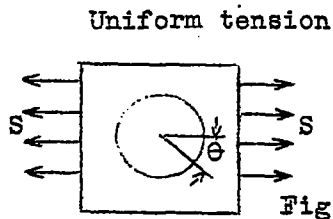
TABLE III.- SPECIMENS TESTED

Similarity group	$\frac{D}{a}$	t nominal	36" frame	22.4" frame	11.25" frame
			a = 28.0"	a = 17.4"	a = 8.75"
			$\frac{t}{a} \times 10^5$	$\frac{t}{a} \times 10^5$	$\frac{t}{a} \times 10^5$
I	0	0.064	228	368	
	0	.051	182		
	0	.040		230	
	0	.032	114	184	360
	0	.020		121	240
II	0.428	0.064	228	368	
	.428	.051	182		
	.428	.040		230	
	.428	.032		181	360
	.428	.020			229
III	0.643	0.064	228		
	.643	.040		230	
	.643	.020			228

14. EXPECTED ERRORS

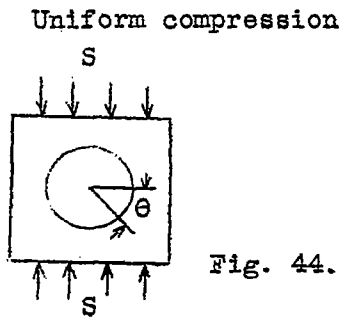
Similarity measurements must be made over geometrically similar regions. This requires that the strains be measured over geometrically similar gage lengths as well as geometrically similar positions. Since the size of the electrical strain gages used for strain measurements was invariable, the strain areas covered by these gages were proportionately larger for the small specimen compared to the large specimen. In regions where the variation in strain is large - that is, near the edge of the central lightening hole - this deviation from similarity may be expected to introduce large variations in the strains measured. To investigate the magnitude of such variations, the following analysis was made.

Stresses in the radial and θ directions near the edge of the hole, due to shear, are first obtained by superimposing uniform tension and compression, equations for which are given by Timoshenko. (See reference 13, p. 77.)



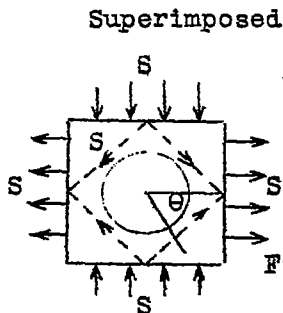
$$\sigma_{\theta} = \frac{S}{2} \left(1 + \frac{b^2}{r^2} \right) - \frac{S}{2} \left(1 + \frac{3b^4}{r^4} \right) \cos 2\theta$$

$$\sigma_r = \frac{S}{2} \left(1 - \frac{b^2}{r^2} \right) + \frac{S}{2} \left(1 + \frac{3b^4}{r^4} - \frac{4b^2}{r^2} \right) \cos 2\theta$$



$$\sigma_{\theta} = -\frac{S}{2} \left(1 + \frac{b^2}{r^2} \right) - \frac{S}{2} \left(1 + \frac{3b^4}{r^4} \right) \cos 2\theta$$

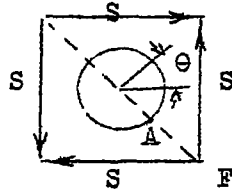
$$\sigma_r = -\frac{S}{2} \left(1 - \frac{b^2}{r^2} \right) + \frac{S}{2} \left(1 + \frac{3b^4}{r^4} - \frac{4b^2}{r^2} \right) \cos 2\theta$$



$$\sigma_{\theta} = -S \left(1 + \frac{3b^4}{r^4} \right) \cos 2\theta$$

$$\sigma_r = S \left(1 + \frac{3b^4}{r^4} - \frac{4b^2}{r^2} \right) \cos 2\theta$$

Stresses at A due to shear.



$$\sigma_{\theta} = S \left(1 + \frac{3b^4}{r^4} \right)$$

$$\sigma_r = -S \left(1 + \frac{3b^4}{r^4} - \frac{4b^2}{r^2} \right)$$

Strain in the θ direction at A due to shear.

$$e_{\theta} = \frac{1}{E} \left(\sigma_{\theta} - \mu \sigma_r \right)$$

$$\frac{E e_{\theta}}{S} = (1 + \mu) \left(1 + \frac{3b^4}{r^4} \right) - 4\mu \frac{b^2}{r^2} = \text{strain concentration}$$

The strain concentration as a function of the radial distance is plotted nondimensionally in figure 47. The position and dimensions of the strain gages are shown in figure 48. For each case, the center line of the tensile gage was 0.34 inch from the edge of the hole. The strain concentration for the various panels and the calculated variations are given in table IV. The analysis indicates a possible strain variation of 39 percent. Variations of this magnitude were found only in one test. However, it should be remembered that in all tests the load was carried well beyond the proportional limit; while the analysis holds only below the proportional limit.

TABLE IV.- STRAIN CONCENTRATION FACTOR FROM FIGURE 47

$\frac{D}{a}$	b (in.)	$r = b + 0.34$	$\frac{b}{r}$	$\frac{E\epsilon}{S}$	Ratio	Variation (percent)
0.428	1.88	2.22	0.846	2.43	1.00	-----
.428	3.73	4.07	.916	3.04	1.25	25
.428	6.00	6.34	.947	3.37	1.39	39
.643	2.81	3.15	.891	2.81	1.00	-----
.643	5.60	5.94	.942	3.31	1.18	18
.643	9.00	9.34	.963	3.56	1.27	27

15. DISCUSSION OF TEST RESULTS

In the test curves (figs. 5 to 12), similarity in the behavior of the specimens of different sizes is demonstrated if the test points for the different specimens fall on a single curve. In several cases this occurs very accurately. In several others there is considerable scatter, raising the question whether this is due to incorrect expectations of similarity, to causes which prevent satisfactions of similarity, or to errors of measurements.

The answer to this question cannot be made with any assurance. No reason can be found for the alinement of test points for one group of specimens and the scatter of points for the same measurements of another group. However, some possible causes for this lack of uniformity can be listed as follows:

1. Possible variation in the properties of the different sheets
2. Variation of sheet thicknesses
3. Sheets were cut and used without reference to the direction of rolling
4. Clearance in the bolt holes, both in the sheets and the frames, is approximately the same for the three sizes of specimen, thereby being proportionately larger for small specimens compared to the large specimens.
5. Exact duplication of similar positions for the electrical strain gages was difficult to obtain.
6. Size effect of electrical strain gages (discussed under errors)
7. Because of large differences in range of loads between large and small specimens, it was necessary to use two different sizes of hydraulic jacks for loading. The release load at the end of each stroke is different for different jacks.
8. The method of measuring lateral deflection of sheets was not entirely satisfactory. A heavy bar was placed across the frame and the distance between it and the sheet was measured. This method was found to be somewhat unreliable in that the frame edges were not always free from rotation.
9. Yielding of test jig is greater for larger specimens and although the diagonal displacement should be independent of any small rotation of the supporting wall, if such rotation produces bending of the frame, it could result in errors of the diagonal measurement.

The average curves of figures 5 to 12 were replotted in figures 13 to 24 to show the variations resulting from changes in t/a and D/a . The results appear reasonable in that none of the curves crossed out of order from their proper domain.

The results as a whole indicate a reasonable degree of similarity attained in most specimens. An average of the probable error of the various measurements was estimated from the curves to be as follows:

	(percent)
e_T	- 8
e_b	- 10
$\frac{\delta}{a}$	- 10
$\frac{y}{a}$	- 15

Variations of at least twice the average errors may be expected in individual measurements. Improvement in the technique of testing and measurement should result in greater accuracy.

16. CONCLUDING REMARKS

The test program was carried out with the degree of accuracy usually met by aircraft industries, and no effort was made to go beyond this in refinements. Considering the difficulty of satisfying accurately to every detail the similarity conditions for thin-walled section, the test results indicate a fair degree of similarity established. It is the authors' opinion that greater accuracy can be obtained with further refinements.

APPENDIX TO PART II

SYMBOLS

- t thickness of sheets
- a inside dimensions of sheet (See fig. 3.)
- D diameter of hole (See fig. 3.)
- P load pounds (See fig. 2.)
- δ displacement along diagonal (See fig. 2.)
- $e_1 e_2 e_3 e_4$ strains
- e_T strain parallel to tension fold
- e_b bending strain \perp to tension fold $\left(\frac{e_3 + e_4}{2}\right)$
- e_c compressive strain \perp to tension fold $\left(\frac{e_3 - e_4}{2}\right)$
- y lateral displacement of sheet

College of Engineering,
 Cornell University,
 Ithaca, N. Y., January 26, 1944.

REFERENCES

1. Buckingham, E.: Phys. Rev. 4, 1914, p. 345; Trans. A.S.M.E., vol. 37, 1915.
- ✓ 2. Bridgman, P. W.: Dimensional Analysis. Yale Univ. Press, 1922.
3. Karpov, A. V., and Templin, R. L.: Model of Calderwood Arch Dam. Trans. ~~Am. Soc. Civ. Eng.~~, vol. 100, 1935, p. 185.
4. Biot, M.: *He presents a method and the resulting formulae for two-dimensional elasticity* *Replaced by* Jour. Appl. Mech., 1935, p. A-41. *Trans. A.S.M.E., vol. 2, no. 2*
- ✓ 5. Theodorsen, T.: Propeller Vibrations and the Effect of the Centrifugal Force. NACA TN No. 516, 1935.
6. Downie-Smith, J. F.: Rubber Springs - Shear Loading. Jour. ~~of~~ Appl. Mech., Dec. 1933, p. A-159; Rubber Mountings. Jour. ~~of~~ Appl. Mech., March 1938, p. A-13.
- ✓ 7. Dalby, W. E.: Strength and Structure of Steel and Other Metals, 1923, p. 72.
8. Peterson, R. E.: Model Testing as Applied to Strength of Materials. Paper APM-55-11, Trans. A.S.M.E., 1933.
- ✓ 9. Timoshenko, S.: Theory of Elastic Stability. McGraw-Hill Book Co., Inc., 1936, p. 58.
10. Marguerre, K.: *on buckling strength of a slightly curved beam.* Die Durchschlagskraft eines schwach gekrümmten Balkens. Sitzungsberichte der Berliner Mathematischen Gesellschaft, vol. 37, 1938, pp. 22.
- ✓ 11. von Kármán, T., Dunn, Louis G., and Tsien, Hsue-Shen: The Influence of Curvature on the Buckling Characteristics of Structures. Jour. ~~of~~ Aero. Sci., vol. 7, no. 7, May 1940, pp. 276-289.
12. Saunders and Windenburg: *D. F.* The Use of Models in Determining the Strength of Thin-Walled Structures. Paper APM-54-25, Trans. A.S.M.E., 1932.
- ✓ 13. Timoshenko, S.: Theory of Elasticity. McGraw-Hill Book Co., Inc., 1934.

$$t = .0325$$

$$a = 8.75^m$$

$$D = 0^m$$

$$\frac{t}{a} = 360 \times 10^{-5}$$

$$\frac{D}{a} = 0$$

P	δ	e_1	e_3	e_4	γ
f	10^{-3}	10^{-3}	10^{-3}	10^{-3}	inch
0	0	0	0	0	0
720	13	.576	- 1.15	.445	
1350	25	.970	- 1.89	.943	.091
1890	41	1.49	- 2.72	1.42	.110
2590	65	2.10	- 3.67	1.97	.130
3300	96	2.75	- 4.64	2.52	.139
3920	111	3.25	- 5.50	2.96	.154
4470	134	3.93	- 7.00	3.75	.179
5100	171	4.75	- 8.60	4.48	.200
5480	193	5.63	-10.10	5.03	.217
5880	226	6.66	-11.50	5.45	.222
6260	262	7.80	-13.1	5.75	.230

$$t = .064$$

$$a = 17.4^m$$

$$D = 0$$

$$\frac{t}{a} = 368 \times 10^{-5}$$

$$\frac{D}{a} = 0$$

P	δ	e_1	e_3	e_4	γ
f	10^{-3}	10^{-3}	10^{-3}	10^{-3}	inch
0	0	0	0	0	0
2000	20	.288	- .629	.210	
4000	43	.734	- 1.42	.655	
6000	68	1.15	- 2.20	1.18	.203
8000	99	1.57	- 2.96	1.76	
10000	124	1.99	- 3.80	2.31	
12000	157	2.41	- 4.58	2.80	.312
14000	192	2.88	- 5.55	3.38	
16000	220	3.38	- 6.84	4.08	.391

P/a^2E	$\frac{\delta}{a}$	e_1	e_3	e_4	$\frac{\gamma}{a}$
10^{-6}	10^{-3}	10^{-3}	10^{-3}	10^{-3}	10^{-3}
0	0	0	0	0	0
.89	1.49	.58	- .35	.80	
1.68	2.86	.97	- .48	1.42	10.4
2.35	4.69	1.49	- .65	2.07	12.6
3.22	7.43	2.10	- .85	2.82	14.9
4.10	11.0	2.75	-1.06	3.58	15.9
4.88	12.7	3.25	-1.27	4.23	17.6
5.56	15.4	3.93	-1.63	5.38	20.2
6.35	19.5	4.75	-2.06	6.54	23.8
6.83	22.0	5.63	-2.54	7.57	24.8
7.32	25.8	6.66	-3.03	8.48	25.4
7.80	29.9	7.80	-3.68	9.43	26.3

P/a^2E	$\frac{\delta}{a}$	e_1	e_3	e_4	$\frac{\gamma}{a}$
10^{-6}	10^{-3}	10^{-3}	10^{-3}	10^{-3}	10^{-3}
0	0	0	0	0	0
.63	1.15	.29	- .21	.42	
1.26	2.47	.73	- .39	1.04	
1.89	3.91	1.15	- .51	1.69	11.7
2.51	5.72	1.57	- .60	2.36	
3.14	7.30	1.99	- .75	3.06	
3.78	9.05	2.41	- .89	3.69	15.4
4.40	11.0	2.88	-1.09	4.47	
5.03	12.6	3.38	-1.38	5.46	22.4

t = .040
 a = 17.4
 D = 0

t = 230 x 10⁻⁵
 a = 0
 D = 0

P	δ	e_1	e_2	e_3	e_4	γ
#	10 ⁻³	10 ⁻³	10 ⁻³	10 ⁻³	10 ⁻³	inch
0	0	0	0	0	0	0
1000	8	.13	.21	-.31	.0	
2000	19	.42	.50	-.84	.34	
3000	40	.71	.79	-1.34	.53	
4000	67	1.10	1.18	-1.95	.97	.203
5000	80	1.36	1.44	-2.41	1.31	
6000	88	1.68	1.78	-3.10	1.78	
7000	122	2.05	2.15	-3.88	2.28	
8000	140	2.41	2.54	-4.53	2.65	.328
9000	158	2.78	2.94	-5.22	3.04	
10000	177	3.20	3.36	-6.01	3.43	
11000	196	3.59	3.78	-6.87	3.88	
12000	220	4.12	4.30	-7.86	4.35	.422
13000	246	4.67	4.90	-8.97	4.85	
14000	276	5.40	5.63	-10.2	5.35	
15000	311	6.35	6.53	-11.6	5.88	.469

P/a^2R	$\frac{\delta}{a}$	e_1	e_2	e_3	$\frac{\gamma}{R}$
10 ⁻⁶	10 ⁻³	10 ⁻³	10 ⁻³	10 ⁻³	10 ⁻³
0	0	0	0	0	0
.31	.46	.17	-.15	.15	
.63	1.09	.46	-.25	.59	
.94	2.29	.75	-.36	.99	
1.26	3.84	1.14	-.49	1.46	11.7
1.57	4.59	1.40	-.55	1.86	
1.89	5.05	1.73	-.66	2.44	
2.2	7.00	2.10	-.80	3.08	
2.52	8.05	2.48	-.94	3.59	18.8
2.83	9.08	2.86	-1.09	4.13	
3.14	10.2	3.28	-1.29	4.72	
3.46	11.3	3.68	-1.49	5.38	
3.77	12.6	4.21	-1.76	6.11	24.2
4.08	14.1	4.78	-2.06	6.91	
4.40	15.8	5.52	-2.43	7.78	
4.72	17.8	6.44	-2.86	8.74	26.9

t = .021
 a = 8.75
 D = 0

t = 240 x 10⁻⁵
 a = 0
 D = 0

P	δ	e_1	e_2	e_3	e_4	γ
#	10 ⁻³	10 ⁻³		10 ⁻³	10 ⁻³	inch
0	0	0		0	0	0
283	6	.21		-.34	-.10	
665	16	.71		.39	-1.18	.048
1048	34	1.23		.73	-1.94	.065
1430	54	1.70		.79	-2.36	.099
1810	69	2.18		1.18	-3.07	.110
2240	87	2.65		1.63	-3.93	.122
2530	101	3.02		2.02	-4.62	
2640	105	3.09		2.10	-4.77	.133
3020	123	3.64		3.30	-6.45	.140
3380	142	4.20		3.88	-7.50	.146
3530	155	4.56		4.20	-8.19	.156
3650	168					
3730	179					
3830	190					

P/a^2R	$\frac{\delta}{a}$	e_1	e_2	e_3	$\frac{\gamma}{R}$
10 ⁻⁶	10 ⁻³	10 ⁻³	10 ⁻³	10 ⁻³	10 ⁻³
0	0	0	0	0	0
.35	.69	.21	-.22	.12	
.63	1.83	.71	-.39	.79	5.5
1.31	3.88	1.23	-.60	1.33	7.4
1.78	6.17	1.70	-.79	1.58	10.1
2.25	7.89	2.18	-.95	2.13	12.6
2.79	9.95	2.65	-1.15	2.78	13.9
3.15	11.6	3.02	-1.30	3.32	
3.29	12.0	3.09	-1.34	3.41	15.2
3.76	14.1	3.64	-1.57	4.88	16.0
4.21	16.2	4.20	-1.81	5.69	16.7
4.40	17.7	4.56	-1.99	6.20	17.8
4.55	19.2				
4.65	20.5				
4.77	21.7				

$$t = .064$$

$$a = 28^{\circ}$$

$$D = 0$$

$$\frac{t}{a} = 230 \times 10^{-5}$$

$$\frac{D}{a} = 0$$

P	δ	e_1	e_3	e_4	γ
#	10^{-3}	10^{-3}	10^{-3}	10^{-3}	inch
0	0	0	0	0	0
4000	25	.42	-.64	.37	.063
8000	57	.94	-1.57	.79	.235
12000	101	1.34	-2.10	1.00	.297
16000	148	1.76	-2.49	1.13	.328
20000	192	2.20	-3.04	1.44	.407
24000	232	2.65	-3.75	1.78	.438
28000	280	3.20	-4.51	2.20	.498
32000	322	3.78	-5.20	2.62	.545

$P/a^2 E$	$\frac{\delta}{a}$	e_T	e_c	e_b	Z_a
10^{-6}	10^{-3}	10^{-3}	10^{-3}	10^{-3}	10^{-3}
0	0	0	0	0	0
.49	.90	.42	-.24	.61	2.2
.97	2.04	.94	-.39	1.18	8.5
1.45	3.62	1.34	-.55	1.55	10.6
1.94	5.30	1.76	-.68	1.80	11.7
2.42	6.85	2.20	-.80	2.24	14.5
2.90	8.3	2.65	-.99	2.77	15.7
3.38	10.0	3.20	-1.05	3.25	17.8
3.87	11.5	3.78	-1.3	3.90	19.5

$$t = .032$$

$$a = 17.4$$

$$D = 0$$

$$\frac{t}{a} = 184 \times 10^{-5}$$

$$\frac{D}{a} = 0$$

P	δ	e_1	e_3	e_4	γ
#	10^{-3}	10^{-3}	10^{-3}	10^{-3}	inch
0		0	0	0	0
1000		.26	-.52	.26	
2000		.58	-.92	.44	
3000		.94	-1.47	.73	
4000		1.39	-1.97	.99	.172
5000		1.76	-2.41	1.26	.203
6000		2.10	-2.88	1.49	
7000		2.46	-3.77	1.97	.250
8000		2.96		2.38	
9000		3.40	-5.42	2.78	.282
10000		3.96	-6.52	3.20	.297
11000		4.64	-7.89	3.75	.313
12000		5.80	-9.96	4.58	.375
13000		7.02	-11.8	5.14	
14000		8.46	-13.5	5.48	.406
15000		10.4	-15.5	5.61	.422

$P/a^2 E$	$\frac{\delta}{a}$	e_T	e_c	e_b	Z_a
10^{-6}	10^{-3}	10^{-3}	10^{-3}	10^{-3}	10^{-3}
0		0	0	0	0
.31		.26	-.13	.39	
.63		.58	-.24	.68	
.94		.94	-.37	1.10	
1.26		1.39	-.49	1.48	9.9
1.57		1.76	-.58	1.84	11.7
1.89		2.10	-.69	2.24	
2.20		2.46	-.90	2.87	14.4
2.51		2.96			
2.83		3.40	-1.32	4.10	16.2
3.14		3.96	-1.66	4.86	17.1
3.46		4.64	-2.07	5.82	18.0
3.77		5.80	-2.69	7.27	21.5
4.08		7.02	-3.33	8.47	
4.40		8.46	-4.01	9.49	23.3
4.72		10.40	-4.95	10.56	24.2

$$t = .051$$

$$n = 28$$

$$D = 0$$

$$\frac{t}{E} = 182 \times 10^{-5}$$

$$\frac{D}{E} = 0$$

P	δ	σ_1	σ_3	σ_4	γ
+	10^{-3}	10^{-3}	10^{-3}	10^{-3}	inch
0		0	0	0	0
1000		.18	.136	-.236	
2000		.31	.262	-.472	
4000		.63	.456	-.865	.218
6000		.92	.734	-1.34	
8000		1.21	.918	-1.68	.312
10000		1.47	1.10	-2.02	
12000		1.78	1.26	-2.36	.344
14000		2.02	1.44	-2.65	
16000		2.28	1.57	-3.10	.375
18000		2.49	1.76	-3.30	
20000		2.80	1.94	-3.70	.420
22000		3.04	2.05	-4.04	
23000		3.22	2.15	-4.32	
24000		3.44	2.28	-4.59	
25000					.476

$P/2E$	σ_1	σ_3	σ_4	γ
10^{-6}	10^{-3}	10^{-3}	10^{-3}	10^{-3}
0	0	0	0	0
.12	.18	-.05	.18	
.24	.31	-.11	.37	
.48	.63	-.21	.66	7.8
.72	.92	-.30	1.04	
.97	1.21	-.38	1.30	11.1
1.20	1.47	-.46	1.66	
1.45	1.78	-.55	1.81	12.3
1.70	2.02	-.61	2.05	
1.94	2.28	-.76	2.34	13.4
2.18	2.49	-.77	2.53	
2.42	2.80	-.88	2.82	15.0
2.67	3.04	-1.00	3.05	
2.79	3.22	-1.09	3.24	
2.97	3.44	-1.16	3.44	17.0
3.03				

$$t = .021$$

$$n = 17.4$$

$$D = 0$$

$$\frac{t}{E} = 121 \times 10^{-5}$$

$$\frac{D}{E} = 0$$

P	δ	σ_1	σ_3	σ_4	γ
+	10^{-3}	10^{-3}	10^{-3}	10^{-3}	inch
0	0	0	0	0	0
1000	2	.393	-.665	.21	
2000	41	.916	-1.39	.55	.110
3000	65	1.52	-2.20	.944	.156
4000	82	2.10	-2.80	1.13	
5000	104	2.64	-3.54	1.49	.172
6000	132	3.14	-4.19	1.78	.219
7000	165	3.85	-5.24	2.18	
8000	202	4.69	-6.16	2.33	.281
9000	266	6.16	-7.86	2.67	
10000	390	9.10	-10.85	3.06	.328
10500	437	10.5	-11.95	2.96	

$P/2E$	σ_1	σ_3	σ_4	γ
10^{-6}	10^{-3}	10^{-3}	10^{-3}	10^{-3}
0	0	0	0	0
.31	1.11	.39	-.23	.44
.63	2.36	.92	-.42	.87
.94	3.73	1.52	-.63	1.57
1.26	4.71	2.10	-.84	1.97
1.57	5.98	2.64	-1.03	2.52
1.89	7.58	3.14	-1.20	2.98
2.20	9.48	3.85	-1.53	3.71
2.51	11.6	4.69	-1.92	4.25
2.83	15.3	6.16	-2.59	5.26
3.14	22.4	9.10	-3.89	6.96
3.30	25.1	10.5	-4.49	7.46

$$t = .032$$

$$a = 26.0$$

$$D > 0$$

$$\frac{t}{a} = 114 \times 10^{-5}$$

$$\frac{D}{a} = 0$$

$$t = .064$$

$$a = 17.4$$

$$D = 7.45$$

$$\frac{t}{a} = 368 \times 10^{-5}$$

$$\frac{D}{a} = .428$$

P	δ	ϵ_1	ϵ_2	ϵ_3	ϵ_4	γ
#	10^{-3}	10^{-3}	10^{-3}	10^{-3}	10^{-3}	inch
0	0	0		0		0
2000	16	.21		-.472		
3000	27	.42		-.655		.127
4000	37	.63		-.865		
6000	55	1.05		-1.15		.250
8000	75	1.47		-1.55		
10000	95	1.91		-1.91		.296
12000	115	2.33		-2.31		
14000	143	2.83		-2.83		.375
16000	185	3.28		-3.46		
17000	212	3.59		-3.90		
18000	240	3.88		-4.24		.453
19000	283	4.32		-4.58		

P	δ	ϵ_1	ϵ_2	ϵ_3	ϵ_4	γ
#	10^{-3}	10^{-3}	10^{-3}	10^{-3}	10^{-3}	inch
0	0	0	0	0	0	0
1000	12	.262	.262	-.367	0	
2000	28	.708	.681	-1.13	.603	.0715
3000	44	1.21	1.21	-1.91	1.31	
4000	62	1.84	1.84	-2.75	2.02	.190
5000	73	2.38	2.38	-3.41	2.62	
6000	84	2.99	2.99	-4.09	3.22	.274
7000	94	3.85	3.85	-4.98	4.06	
8000	107	4.74	4.76	-5.87	4.90	.345
9000	117	5.85	5.90	-6.92	5.87	
10000	139	7.44	7.52	-8.36	7.26	.429
11000	164	9.65	9.77	-10.2	9.00	
12000	191	12.0	12.2	-11.9	10.7	.524
13000	223					
14000	247					
15000	299					
16000	353					

P/a^2	$\frac{\delta}{a}$	ϵ_1	ϵ_2	ϵ_3	$\frac{\gamma}{a}$
10^{-6}	10^{-3}	10^{-3}	10^{-3}	10^{-3}	10^{-3}
0	0	0			0
.24	.57	.21			5.7
.36	.96	.42			
.49	1.32	.63			8.9
.73	1.96	1.05			
.97	2.67	1.47			10.6
1.21	3.38	1.91			
1.45	4.21	2.33			13.4
1.70	5.10	2.83			
1.94	6.60	3.28			16.2
2.06	7.55	3.59			
2.18	8.55	3.88			
2.30	10.10	4.32			

P/a^2	$\frac{\delta}{a}$	ϵ_1	ϵ_2	ϵ_3	$\frac{\gamma}{a}$
10^{-6}	10^{-3}	10^{-3}	10^{-3}	10^{-3}	10^{-3}
0	0	0	0	0	0
.31	.69	.26	-.18	.18	4.1
.63	1.61	.69	-.26	.87	10.9
.94	2.52	1.21	-.30	1.61	15.7
1.26	3.56	1.84	-.36	2.39	19.8
1.57	4.19	2.38	-.39	3.02	24.6
1.89	4.82	2.99	-.43	3.66	30.1
2.20	5.40	3.85	-.46	4.52	35.6
2.52	6.15	4.75	-.48	5.39	
2.83	6.72	5.87	-.52	6.39	
3.14	7.98	7.48	-.55	7.81	
3.46	9.42	9.71	-.60	9.60	
3.77	11.0	12.10	-.60	11.3	
4.08	12.8				
4.40	14.2				
4.71	17.2				
5.03	20.3				

$$t = .0315$$

$$n = 8.75^{\circ}$$

$$D = 3.75^{\circ}$$

$$t = 360 \times 10^{-5}$$

$$n = .428$$

$$t = .020$$

$$n = 8.75^{\circ}$$

$$D = 3.75^{\circ}$$

$$t = 229 \times 10^{-5}$$

$$n = .428$$

F	δ	ρ_1	ρ_2	ρ_3	ρ_4	F
f	10^{-3}	10^{-3}	10^{-3}	10^{-3}	10^{-3}	inch
0	0	0	0	0	0	0
718	15	1.07	2.786	1.47	-1.76	
1460	37	2.46	2.20	3.14	-3.59	.116
1970	63	3.86	3.62	4.70	-5.26	.160
2480	91	5.03	5.82	6.37	-7.05	.204
3140	129	10.3	9.90	8.77	-9.60	.276
3770	166			10.7	-11.6	.305
3920	194			12.1	-13.2	.366
4230	230					.389
4380	265					
4620	292					.434

F	δ	ρ_1	ρ_2	ρ_3	ρ_4	F
f	10^{-3}	10^{-3}	10^{-3}	10^{-3}	10^{-3}	inch
0	0	0	0	0	0	0
400	12	- .944	.653	1.23	-1.91	.051
800	25	+ 1.81	1.65	2.36	-3.14	.100
1200	52	3.28	3.17	3.64	-5.00	.159
1600	77	5.35	5.50	4.76	-6.45	.214
2000	105	8.72	9.11	5.90	-7.76	.262
2200	126	11.4	12.5	6.70	-8.70	.292
2400	154	12.9	13.1	6.73	-9.90	.326

$F/2$	δ	ρ_1	ρ_2	ρ_3	Z	
10^{-6}	10^{-3}	10^{-3}	10^{-3}	10^{-3}	10^{-3}	
0	0	0	0	0	0	
.49	1.7	.93	2.15	1.62	13.3	
1.82	4.23	2.33	2.23	3.36	18.3	
2.45	7.20	3.74	1.22	4.68	23.3	
3.03	10.4	5.92	1.34	6.21	23.3	
3.91	14.6	10.1	1.42	9.19	31.5	
4.44	19.0	11.2	1.45	12.7	34.8	
4.88	22.2				41.8	
5.27	26.3				44.4	
5.45	30.3				49.6	
5.75	33.4					

$F/2$	δ	ρ_1	ρ_2	ρ_3	Z	
10^{-6}	10^{-3}	10^{-3}	10^{-3}	10^{-3}	10^{-3}	
0	0	0	0	0	0	
.50	1.37	- .14	.34	1.57	6.0	
1.00	2.86	1.73	.39	2.75	11.3	
1.49	5.94	3.22	.68	4.32	18.0	
1.99	8.80	5.42	.85	5.61	24.2	
2.45	12.0	8.92	.93	6.83	29.6	
2.74	14.4	11.9	1.00	7.70	33.0	
2.99	17.6	13.0	1.09	8.82	36.8	

$$t = .04$$

$$a = 17.4^{\text{in}}$$

$$D = 7.45^{\text{in}}$$

$$\frac{t}{a} = 230 \times 10^{-5}$$

$$\frac{D}{a} = .428$$

P	δ	e_1	e_3	e_4	γ
#	10^{-3}	10^{-3}	10^{-3}	10^{-3}	inch
0	0	0	0	0	0
1000	7	.183	.455	-.735	
2000	27	1.07	1.36	-1.76	.125
3000	54	2.07	2.23	-2.67	
4000	85	3.38	3.09	-3.51	.344
5000	108	4.53	3.70	-4.17	
6000	136	6.27	4.53	-5.03	
7000	165	9.05	5.43	-5.92	
8000	197	12.1	6.25	-6.73	.656
9000	241		7.16	-7.68	

$$t = .064$$

$$a = 26.0^{\text{in}}$$

$$D = 12.0^{\text{in}}$$

$$\frac{t}{a} = 228 \times 10^{-5}$$

$$\frac{D}{a} = .428$$

P	δ	e_1	e_2	e_3	e_4	γ
#	10^{-3}	10^{-3}	10^{-3}	10^{-3}	10^{-3}	inch
0	0	0	0	0	0	0
1000	5	.445	.525	-.131	-.341	
2000	12	.262	.340	-.865	.341	
3000	20	.996	1.05	-1.26	.812	
4000	31	1.36	1.47	-1.62	1.18	.281
6000	51	—	—	-2.12	1.76	
8000	70	—	—	-2.52	2.26	.391
10000	89	4.62	4.80	-2.91	2.65	
12000	111	5.58	5.80	-3.28	3.10	.563
14000	132	6.24	6.47	-3.64	3.51	
16000	156	7.65	7.91	-4.06	3.93	.720
18000	183	9.25	9.57	-4.43	4.35	
20000	217	11.7	12.0	-4.88	4.90	.798

P/a^2E	$\frac{\delta}{a}$	e_1	e_3	e_4	$\frac{\gamma}{a}$
10^{-6}	10^{-3}	10^{-3}	10^{-3}	10^{-3}	10^{-3}
0	0	0	0	0	0
.31	.40	.18	-.14	.60	
.63	1.55	1.07	-.20	1.56	7.2
.94	3.10	2.07	-.22	2.45	
1.26	4.28	3.38	-.21	3.30	19.8
1.57	6.20	4.53	-.23	3.94	
1.88	7.81	6.27	-.25	4.78	
2.20	9.48	9.05	-.25	5.68	
2.52	11.3	12.1	-.24	6.49	37.7
2.83	13.8		-.26	7.42	

P/a^2E	$\frac{\delta}{a}$	e_1	e_3	e_4	$\frac{\gamma}{a}$
10^{-6}	10^{-3}	10^{-3}	10^{-3}	10^{-3}	10^{-3}
0	0	0	0	0	0
.12	.18	.49	-.24	.24	
.24	.43	.30	-.26	.60	
.36	.72	1.02	-.22	1.04	
.49	1.11	1.42	-.22	1.40	10.0
.73	1.82	—	-.18	1.94	
.97	2.50	—	-.13	2.39	13.9
1.21	3.18	4.71	-.13	2.78	
1.45	3.96	5.69	-.09	3.13	20.1
1.70	4.75	6.36	-.07	3.58	
1.94	5.57	7.78	-.07	3.99	25.7
2.18	6.54	9.40	-.04	4.39	
2.42	7.75	11.9	+ .01	4.89	28.5

$t = .0315$
 $a = 17.4^{\circ}$
 $D = 7.45^{\circ}$

$\frac{t}{a} = 181 \times 10^{-5}$
 $\frac{D}{a} = .428$

P	δ	e_1	e_2	e_3	e_4	γ
$\frac{P}{a^2}$	10^{-3}	10^{-3}	10^{-3}	10^{-3}	10^{-3}	inch
0	0	0	0	0	0	0
1000	34	.94	1.49	.888	-1.41	
2000	68	2.38	2.12	1.78	-2.30	.266
3000	103	3.82	3.12	2.58	-3.05	.359
4000	129	4.80	4.80	3.21	-3.73	
5000	161	6.97	6.90	4.10	-4.65	.515
6000	196	10.45	10.3	4.80	-5.38	
7000	260	16.02	17.0	5.75	-6.32	.703
8000	325			6.58	-7.21	
9000	413			7.55	-8.23	.920
10000	511			8.50	-9.10	
11000	626			9.50	-10.14	

$t = .051$
 $a = 28$
 $D = 12^{\circ}$

$\frac{t}{a} = 182 \times 10^{-5}$
 $\frac{D}{a} = .428$

P	δ	e_1	e_2	e_3	e_4	γ
$\frac{P}{a^2}$	10^{-3}	10^{-3}	10^{-3}	10^{-3}	10^{-3}	inch
0	0	0	0	0	0	0
1000	3	.314	-.446	.42		
2000	26	.865	-1.18	1.13	.234	
3000	43	1.49	-1.81	1.76		
4000	61	2.10	-2.23	2.18		
5000	74	2.52	-2.49	2.46		
6000	90	3.04	-2.75	2.72	.485	
8000	122	4.17	-3.25	3.22		
10000	158	5.76	-3.75	3.70	.640	
12000	206	7.97	-4.22	4.20		
14000	246	10.4	-4.58	4.58	.813	
16000	302					
18000	370					
20000	448					

$\frac{P}{a^2}$	$\frac{\delta}{a}$	e_1	e_2	e_3	$\frac{\gamma}{a}$
10^{-6}	10^{-3}	10^{-3}	10^{-3}	10^{-3}	10^{-3}
0	0	0	0	0	0
.31	1.95	1.22	-.26	.58	
.63	3.90	2.25	-.26	2.04	15.3
.94	5.82	3.42	-.23	2.82	20.6
1.26	7.74	4.80	-.26	3.47	
1.57	9.25	6.94	-.28	4.38	29.6
1.88	11.3	10.4	-.29	5.09	
2.20	14.9	16.5	-.29	6.04	40.3
2.51	18.7		-.32	6.90	
2.83	23.7		-.34	7.89	52.8
3.14	29.3		-.30	8.80	
3.46	35.9		-.30	9.82	

$\frac{P}{a^2}$	$\frac{\delta}{a}$	e_1	e_2	e_3	$\frac{\gamma}{a}$
10^{-6}	10^{-3}	10^{-3}	10^{-3}	10^{-3}	10^{-3}
0	0	0	0	0	0
.12	.11	.31	-.01	.43	
.24	.93	.87	-.02	1.16	8.4
.36	1.54	1.49	-.02	1.79	
.49	2.18	2.10	-.02	2.21	
.61	2.64	2.52	-.02	2.48	
.73	3.21	3.04	-.02	2.74	17.3
.97	4.36	4.17	-.02	3.24	
1.21	5.65	5.76	-.02	3.73	22.8
1.45	7.36	7.97	-.01	4.21	
1.70	8.80	10.4	0	4.58	29.0
1.94	10.8				
2.18	13.2				
2.42	16.0				

$$t = .040$$

$$a = 17.4$$

$$p = 11.2^{\circ}$$

$$\frac{t}{a} = 230 \times 10^{-5}$$

$$\frac{D}{a} = .643$$

P	δ	e_1	e_3	e_4	γ
#	10^{-3}	10^{-3}	10^{-3}	10^{-3}	inch
0		0	0	0	0
1000		.58	-1.07	.79	
2000		1.57	-1.92	1.63	.242
3000		3.41	-3.12	2.83	
4000		4.35	-4.20	3.85	.438
5000		8.40	-5.48	5.06	
6000		12.0	-6.81	6.30	.592
7000			-8.52	7.86	
8000			-10.4	9.62	.783

$$t = .064$$

$$a = 28^{\circ}$$

$$p = 18^{\circ}$$

$$\frac{t}{a} = 228 \times 10^{-5}$$

$$\frac{D}{a} = .643$$

P	δ	e_1	e_3	e_4	γ
#	10^{-3}	10^{-3}	10^{-3}	10^{-3}	inch
0	0	0	0	0	0
1000	11	.87	.34	-.45	
2000	27	1.86	.86	-.92	
4000	57	2.70	1.62	-1.65	.468
6000	88	3.59	2.15	-2.10	
8000	121	4.98	2.67	-2.56	.687
10000	154	6.78	3.21	-3.04	
12000	193	9.60	3.77	-3.54	.843
14000	246		4.50	-4.19	
16000	312		5.37	-5.03	1.090
18000	398		6.45	-5.95	

P/a^2E	δ	e_1	e_3	e_4	γ
10^{-6}		10^{-3}	10^{-3}	10^{-3}	10^{-3}
0		0	0	0	0
.31		.58	-.14	.93	
.63		1.57	-.15	1.78	13.9
.94		3.41	-.15	2.98	
1.26		4.35	-.18	4.03	25.2
1.57		8.40	-.21	5.27	
1.88		12.0	-.26	6.56	34.0
2.20			-.33	8.19	
2.52			-.39	10.01	45.0

P/a^2E	δ	e_1	e_3	e_4	γ
10^{-6}	10^{-3}	10^{-3}	10^{-3}	10^{-3}	10^{-3}
0	0	0	0	0	0
.12	.39	.87	-.06	.40	
.24	.97	1.86	-.03	.89	
.49	2.04	2.70	-.02	1.64	16.7
.73	3.14	3.59	+0.03	2.13	
.97	4.32	4.98	+0.06	2.62	24.5
1.21	5.50	6.78	+0.09	3.13	
1.45	6.90	9.60	+0.12	3.66	30.1
1.70	8.80		+0.16	4.35	
1.94	11.2		+0.17	5.20	39.0
2.18	14.2		+0.25	6.20	

$$t = .020$$

$$\frac{t}{a} = 228 \times 10^{-5}$$

$$a = 8.75''$$

$$D = 5.62''$$

$$\frac{D}{a} = .643$$

P	δ	e_1	e_2	e_3	e_4	y
#	10^{-3}	10^{-3}	10^{-3}	10^{-3}	10^{-3}	inch
0	0	0	0	0	0	0
95	3	.340	.21	-.445	.445	
203	7	.603	.445	-.813	.786	
284	11	.865	.708	-1.18	1.11	.028
410	16	1.23	1.05	-1.57	1.47	.055
590	26	1.81	1.60	-2.15	1.99	.105
870	42	2.67	2.44	-2.91	2.67	.158
1077	52	3.46	3.22	-3.48	3.20	.179
1410	79	5.23	5.13	-4.58	4.22	.240
1690	104	7.75	7.68	-5.66	5.22	.290
1840	123	9.78	9.67	-6.35	5.85	.310
1910	134	11.10	11.10	-6.72	6.24	.338
2060	158			-7.44	6.84	

$P/a^2 E$	$\frac{\delta}{a}$	e_T	e_c	e_b	$\frac{y}{a}$
10^{-6}	10^{-3}	10^{-3}	10^{-3}	10^{-3}	10^{-3}
0	0	0	0	0	0
.12	.34	.26	0	.44	
.25	.80	.52	-.01	.80	
.35	1.26	.79	-.04	1.15	3.2
.51	1.83	1.14	-.05	1.52	6.3
.74	2.97	1.70	-.08	2.07	12.0
1.08	4.58	2.56	-.14	2.79	18.1
1.34	5.95	3.34	-.14	3.34	21.5
1.76	9.04	5.18	-.18	4.40	27.4
2.10	11.9	7.72	-.22	5.44	33.1
2.29	14.1	9.73	-.25	6.10	35.4
2.38	15.3	11.10	-.24	6.48	38.6
2.56	18.1		-.30	7.14	

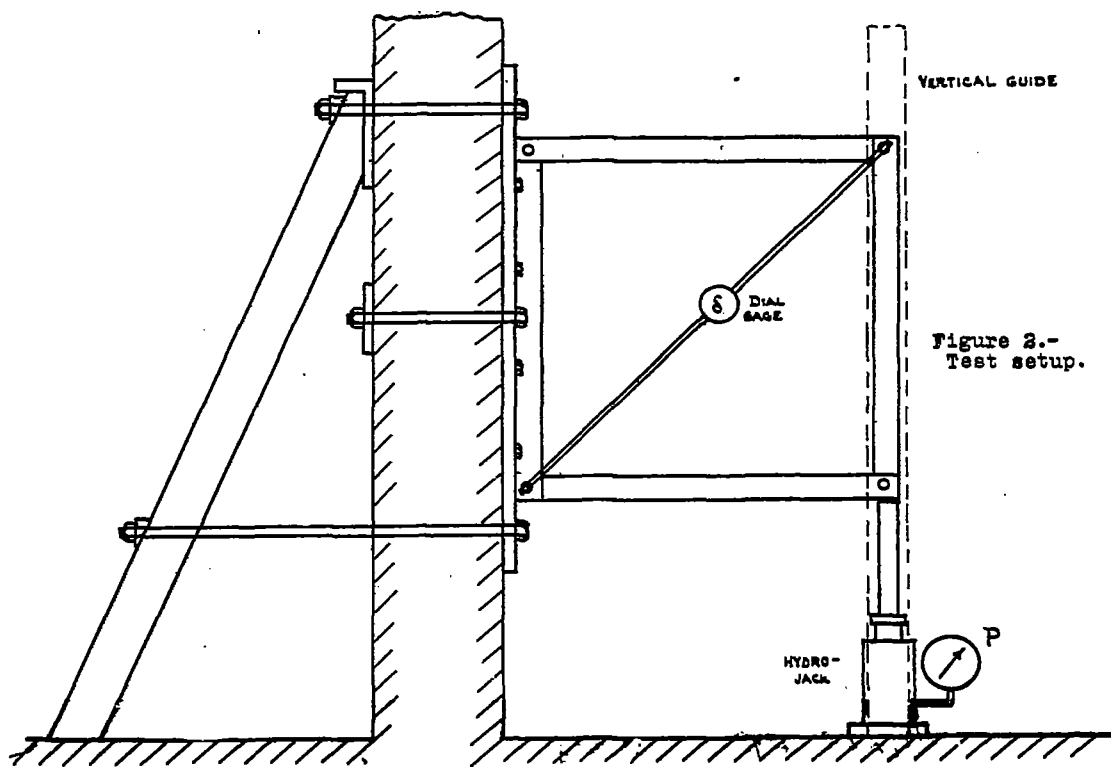


Figure 2.-
Test setup.

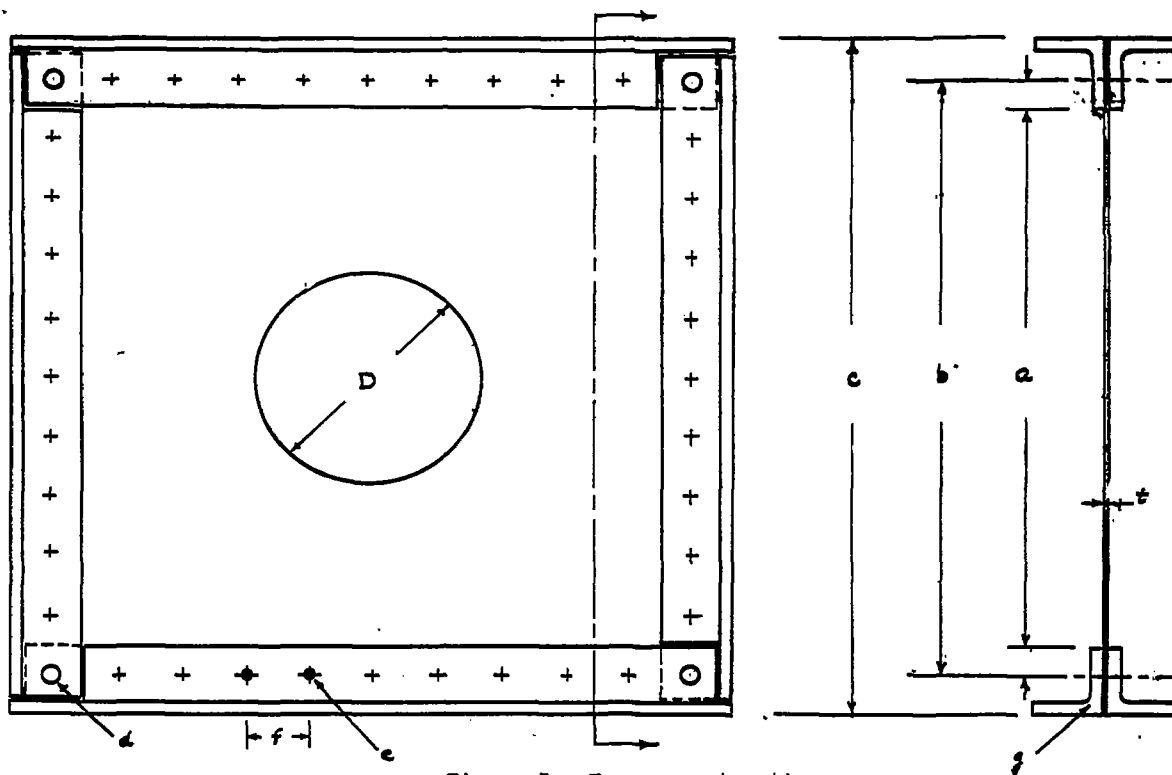


Figure 3.- Frame construction.

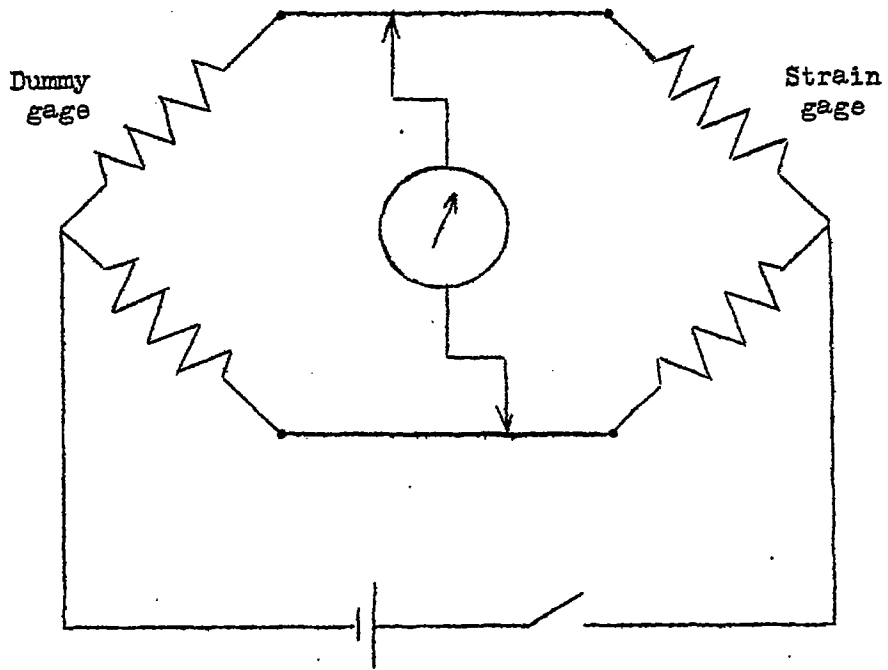
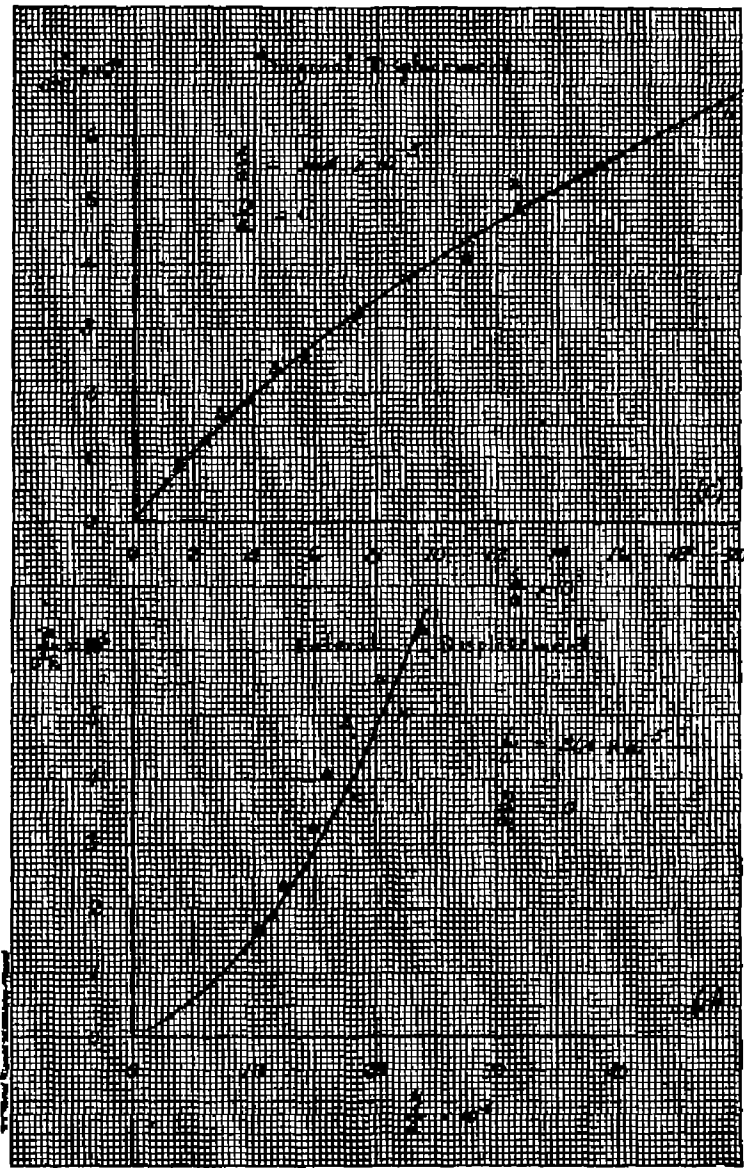
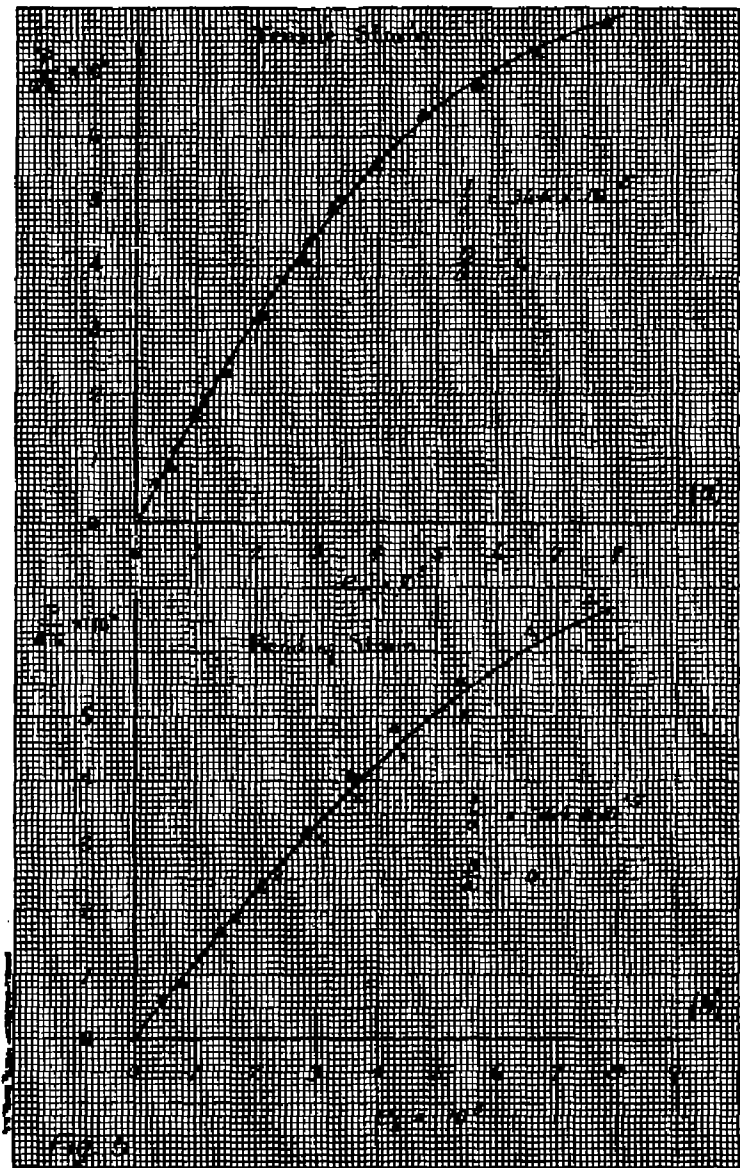
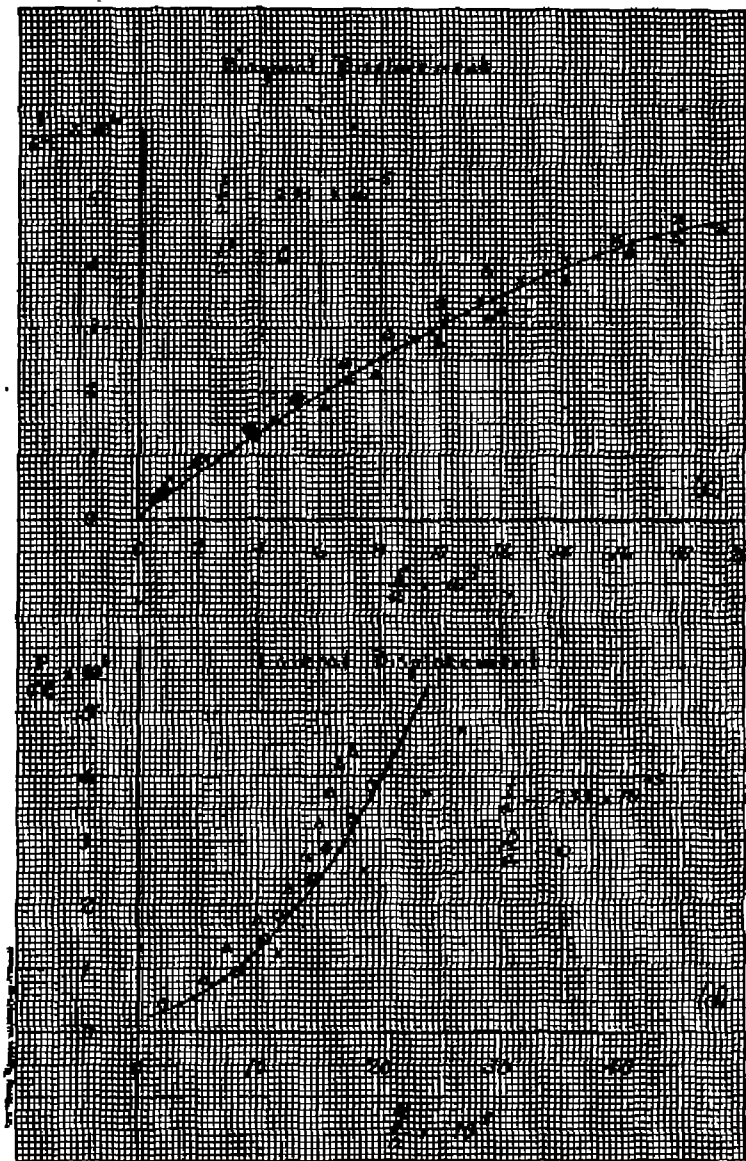
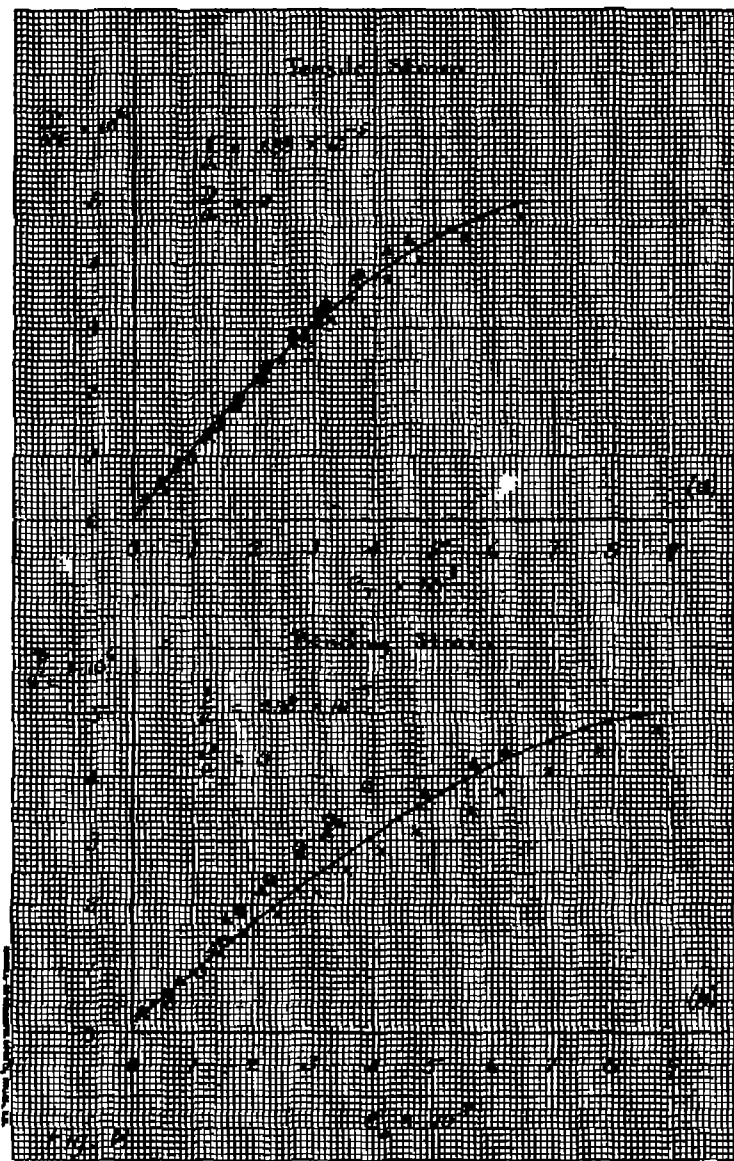
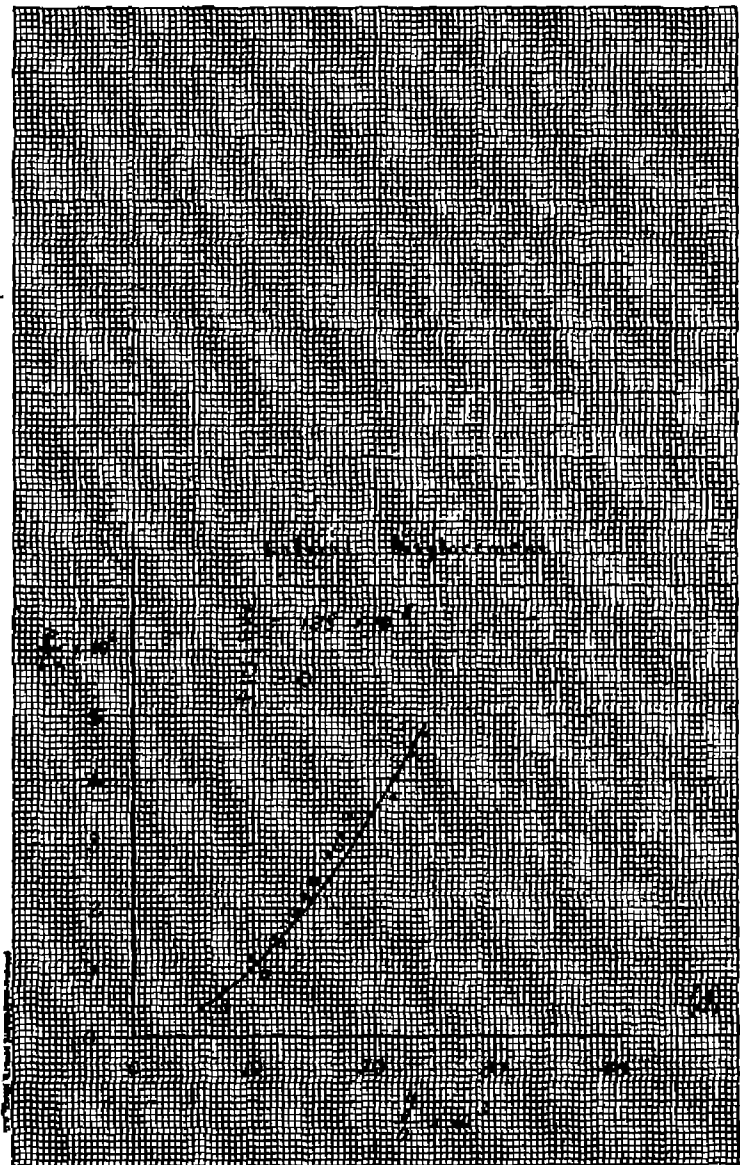
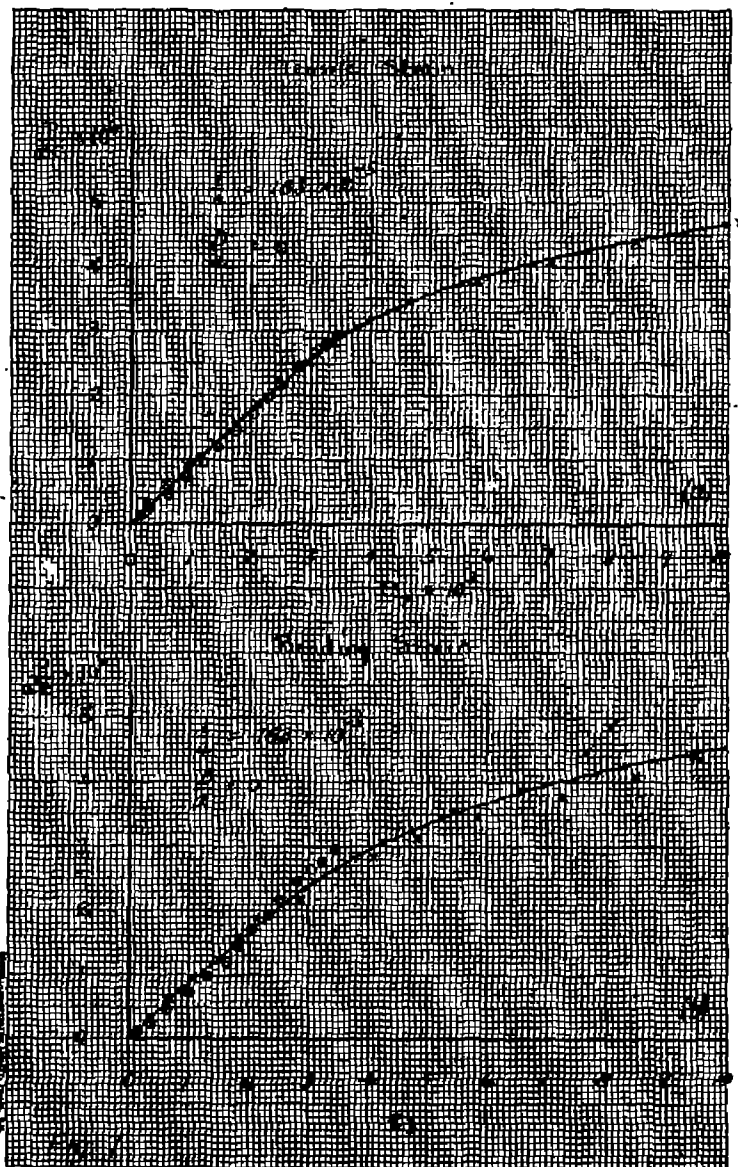
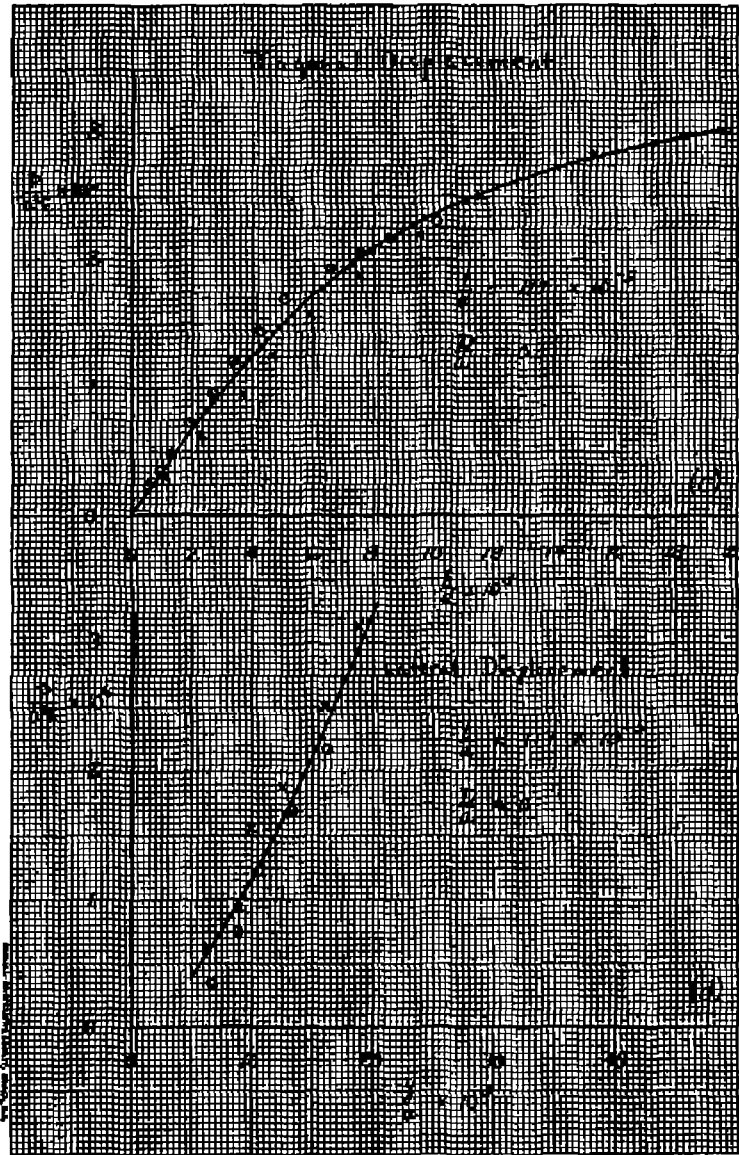
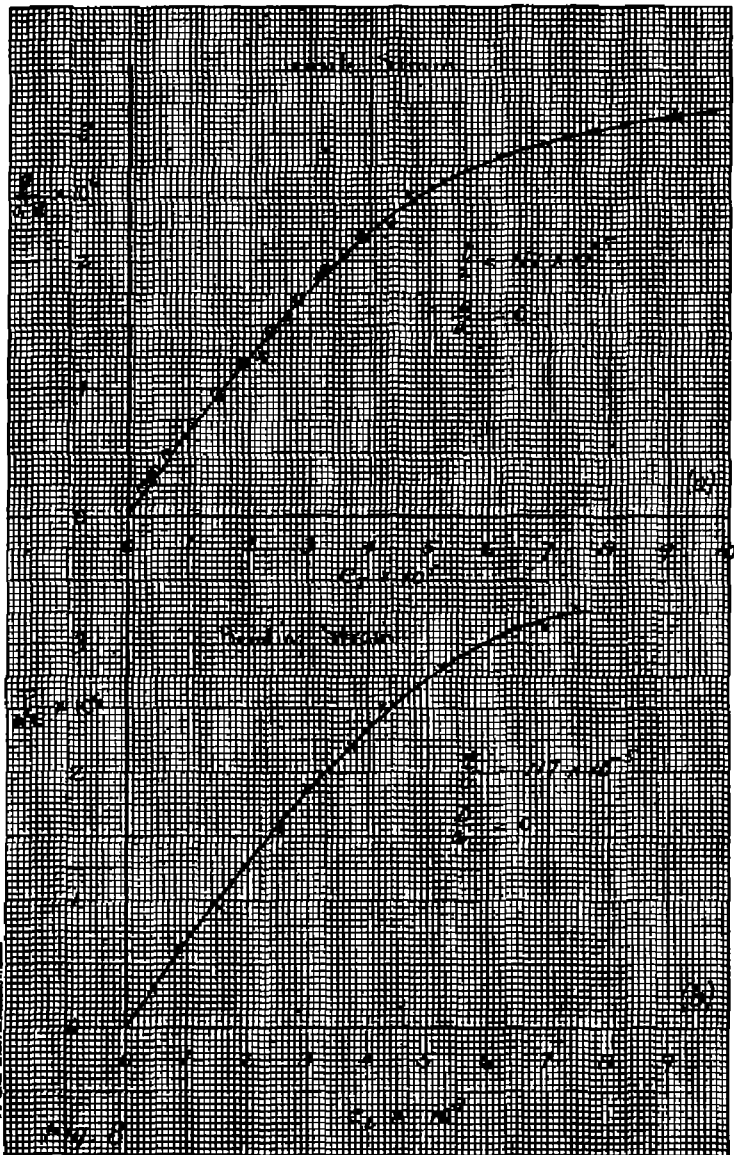


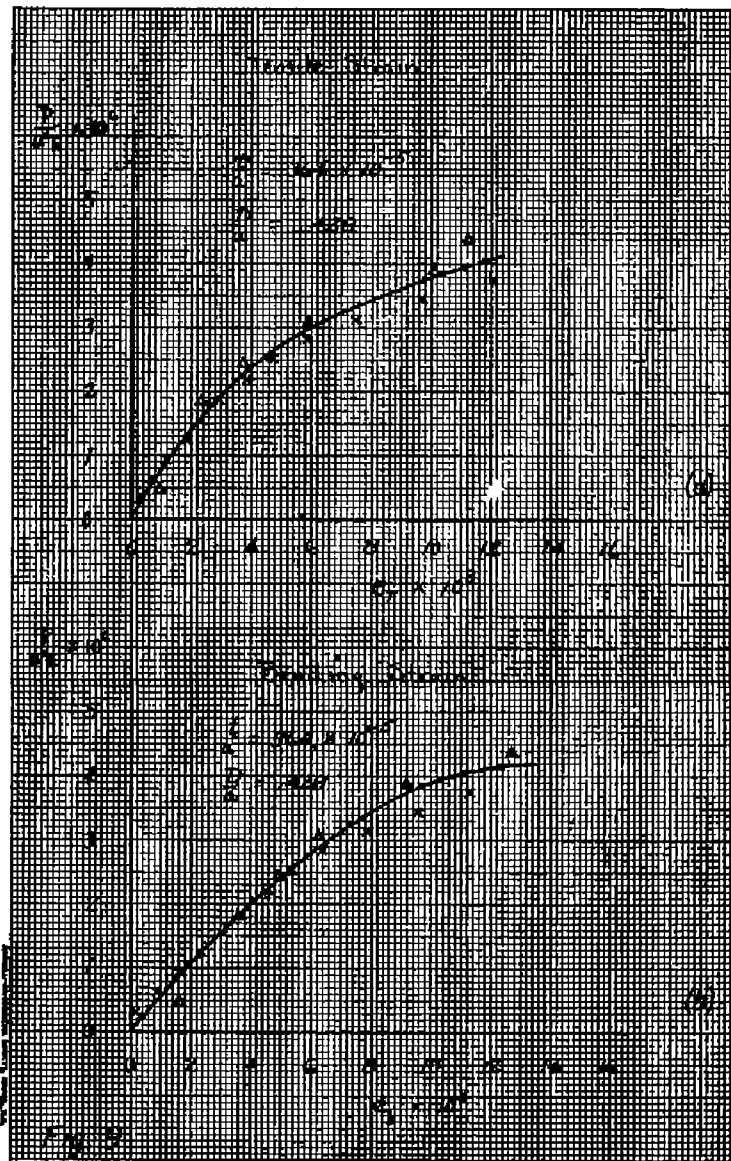
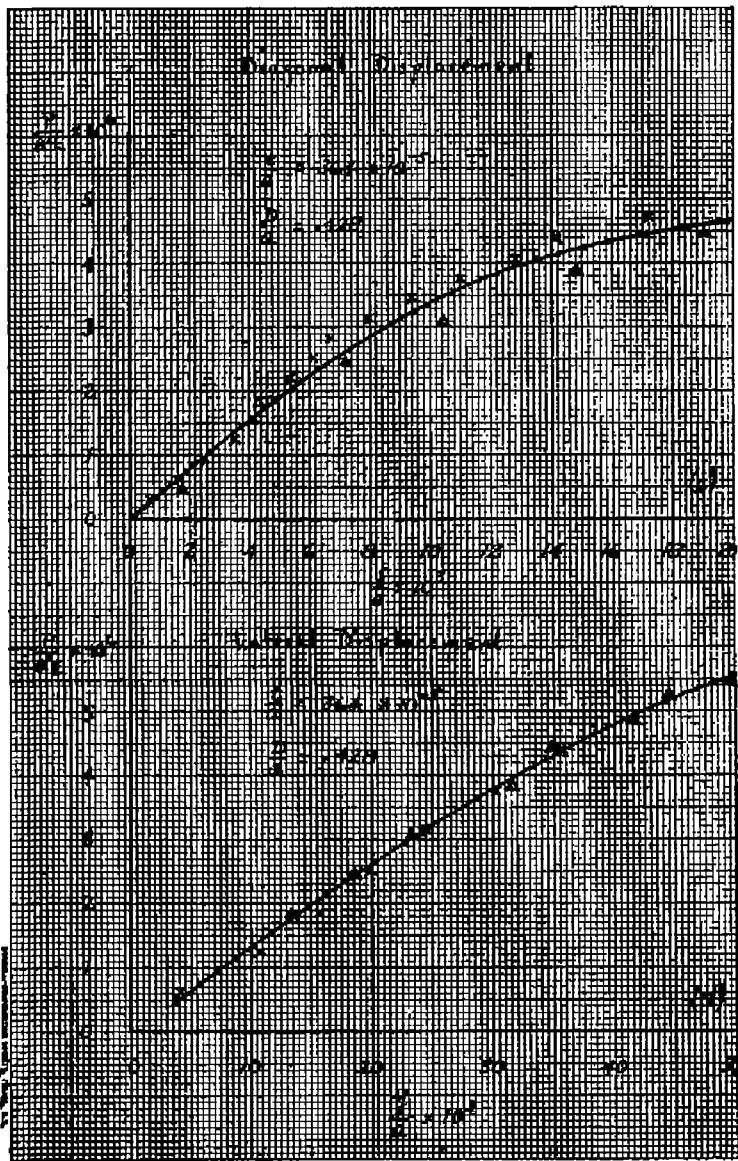
Figure 4.- Electrical strain gage circuit.

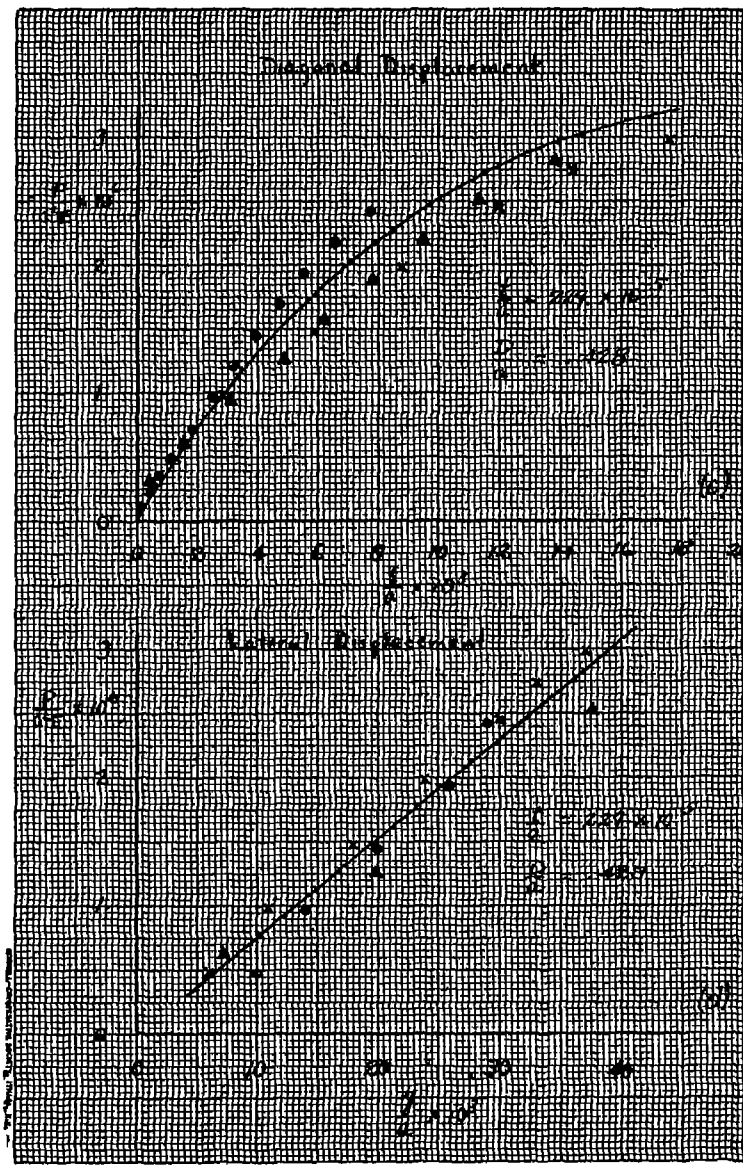
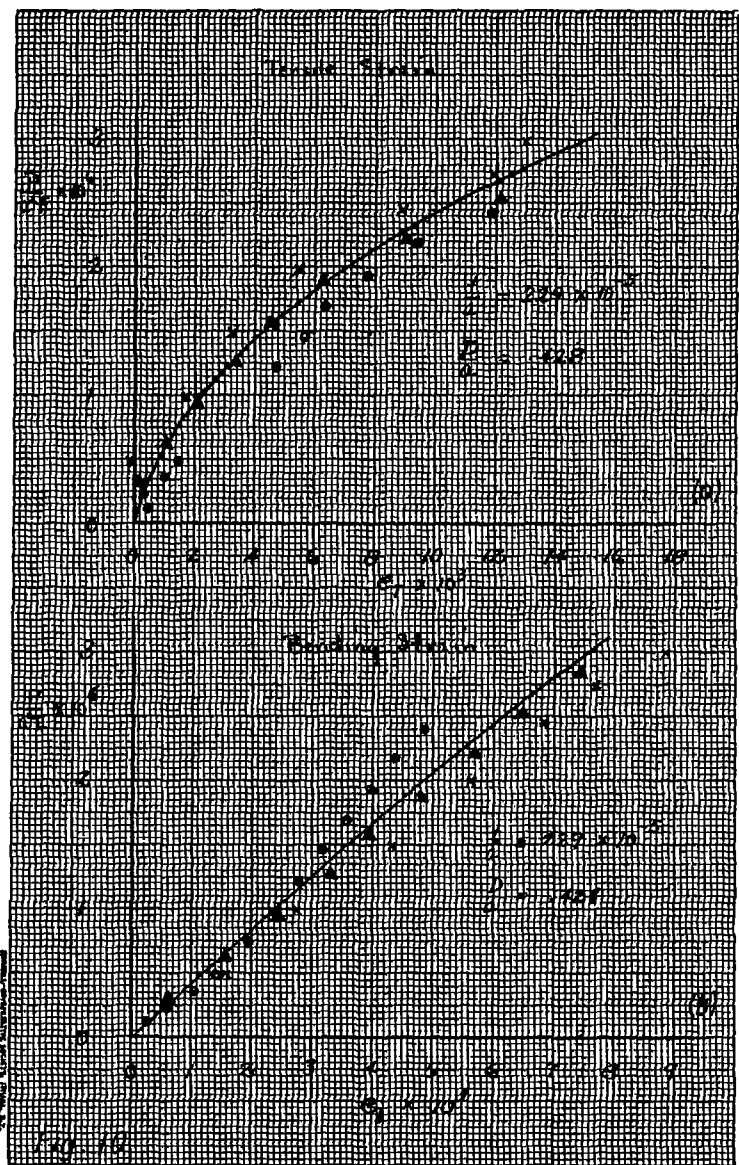












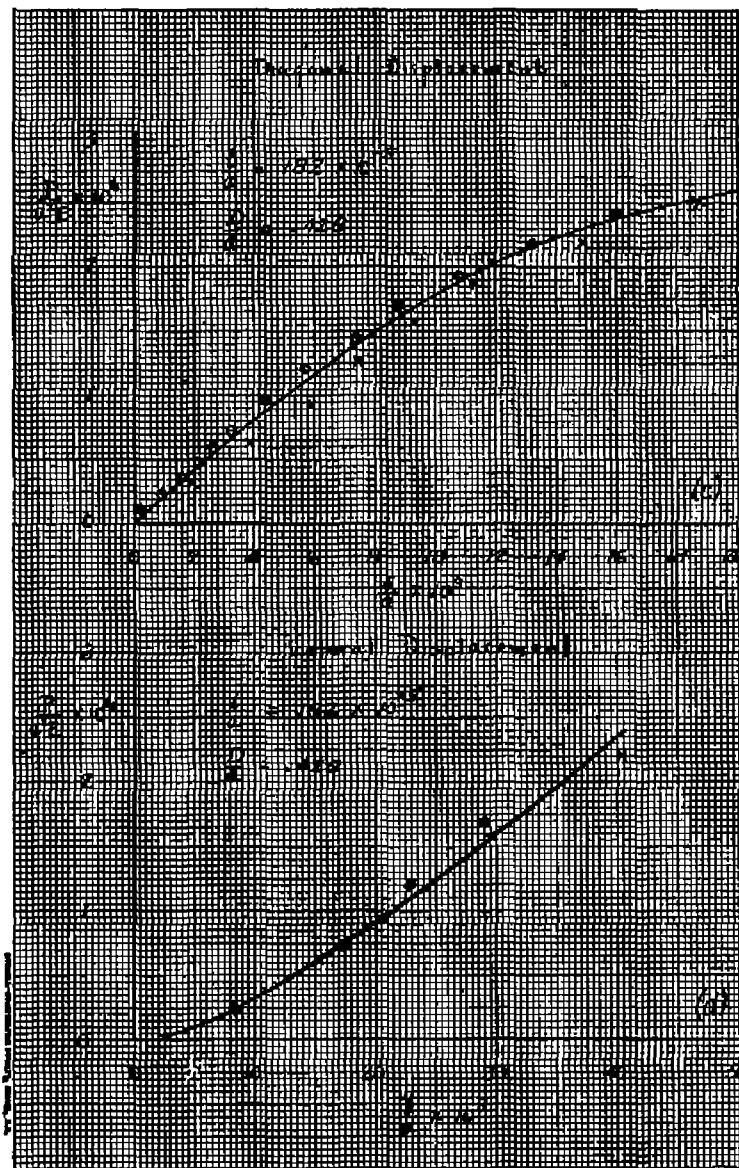
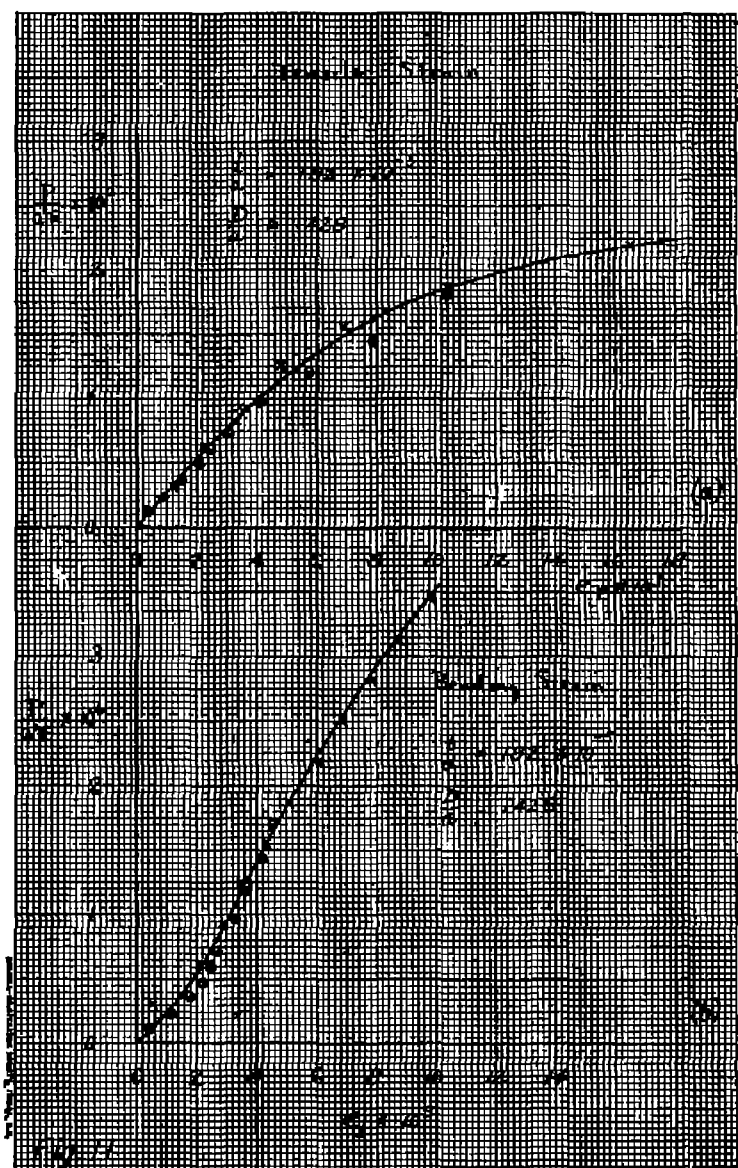
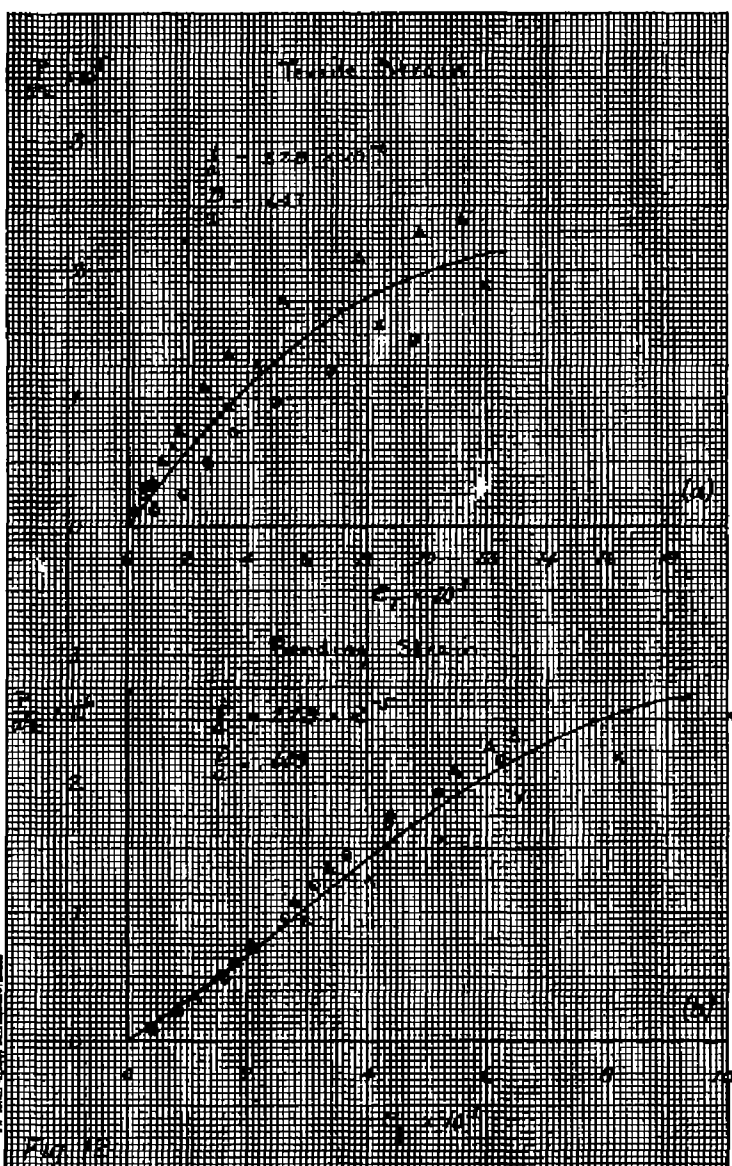
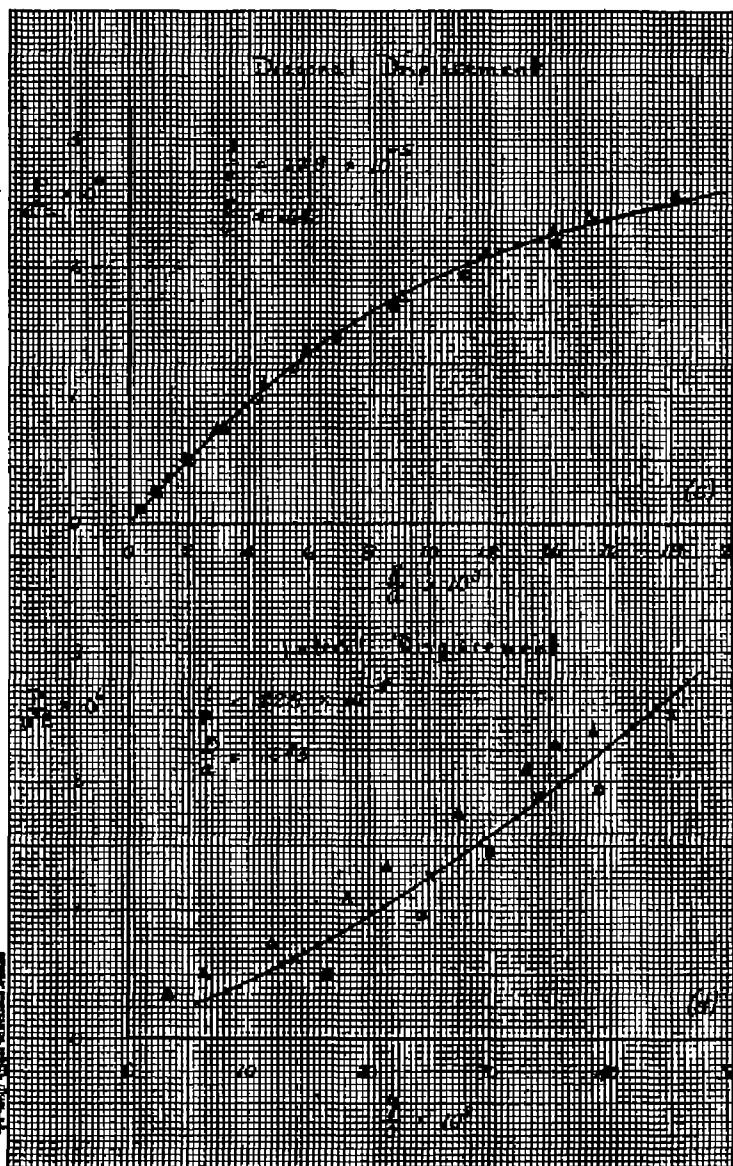
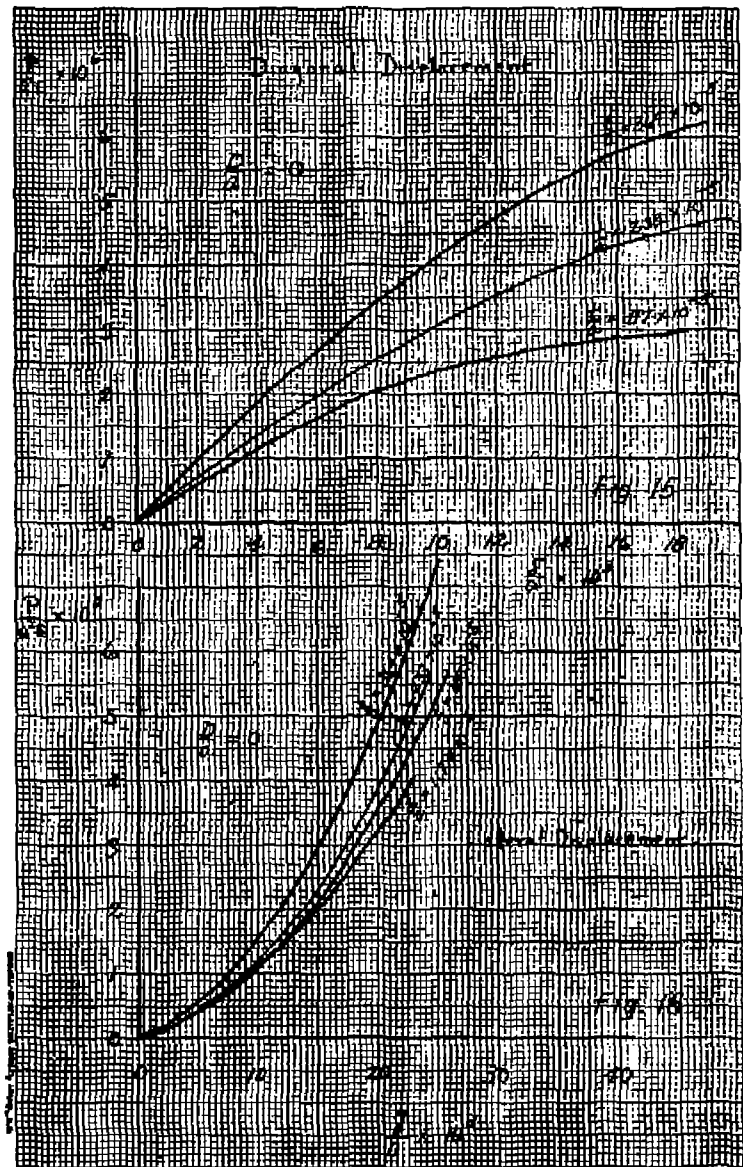
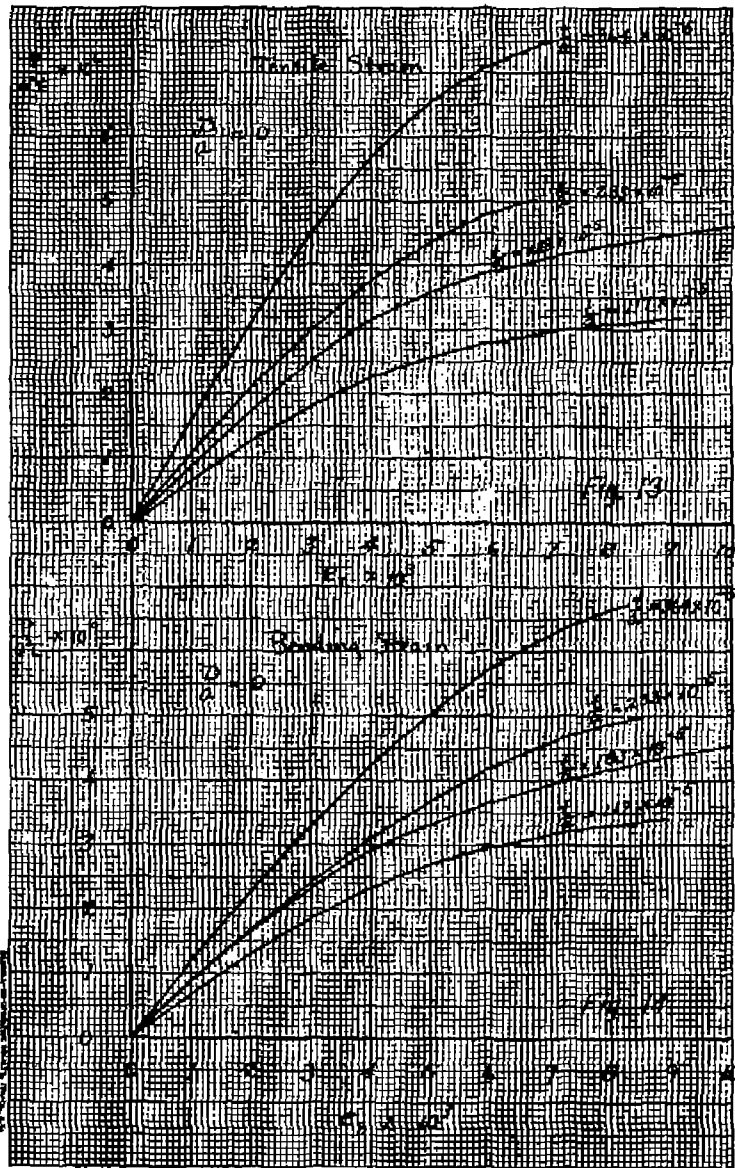
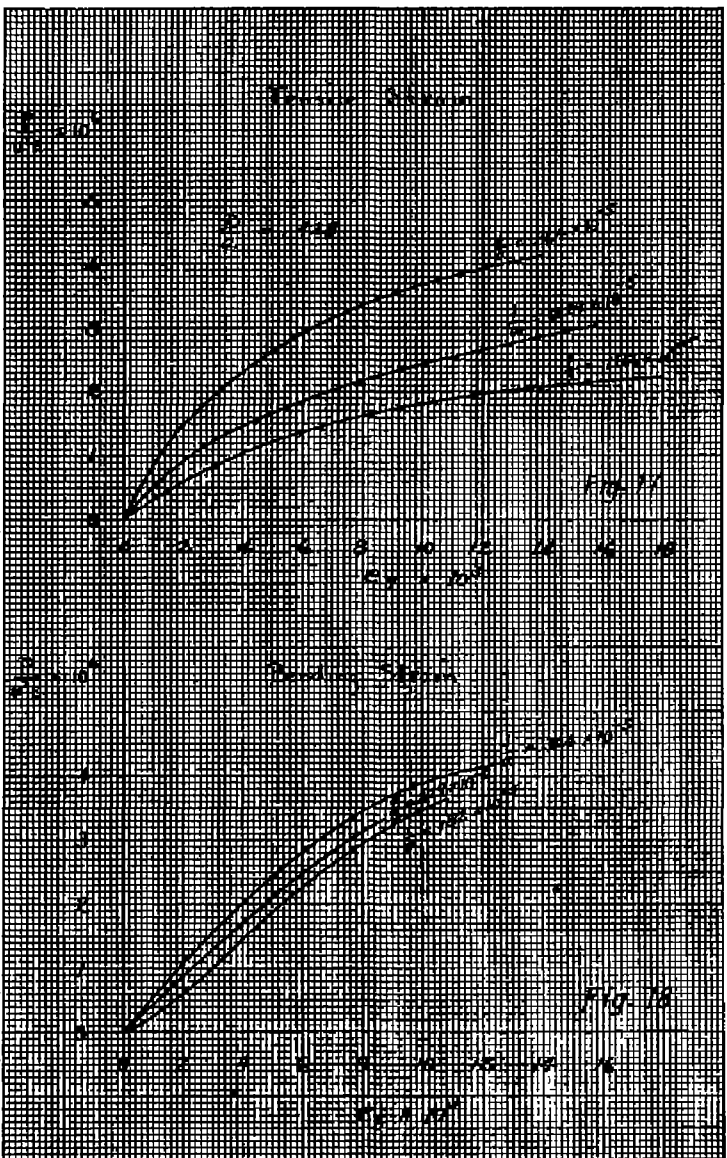
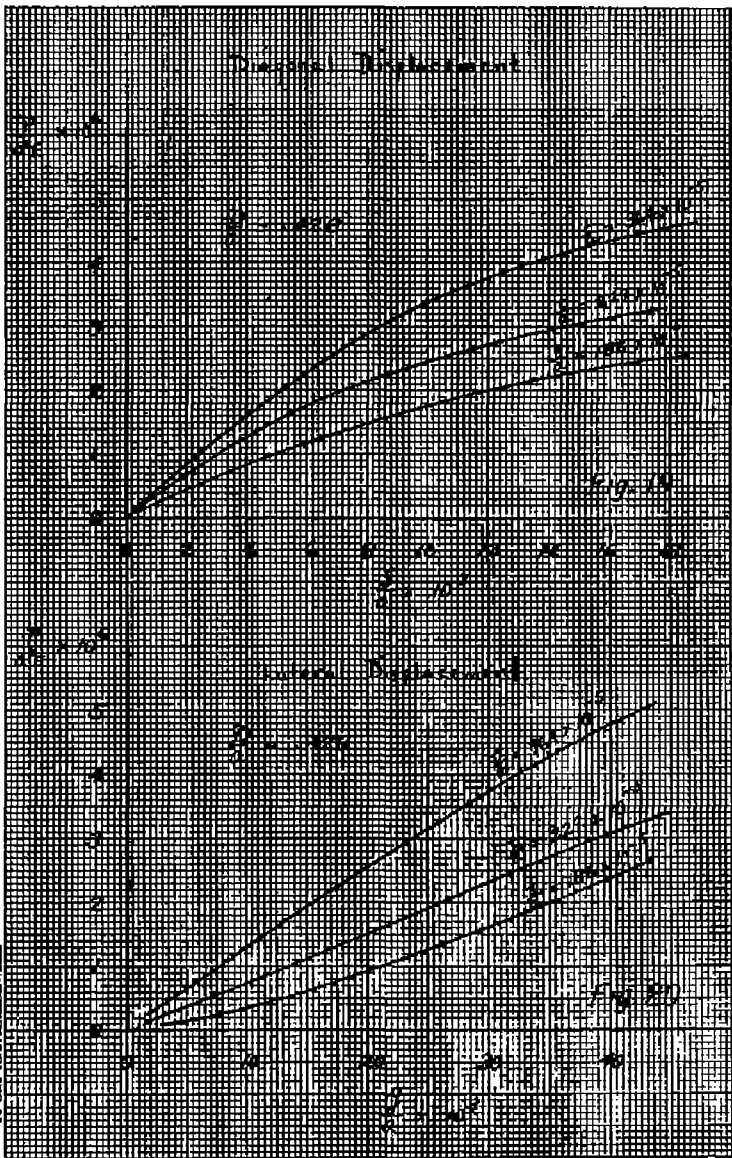


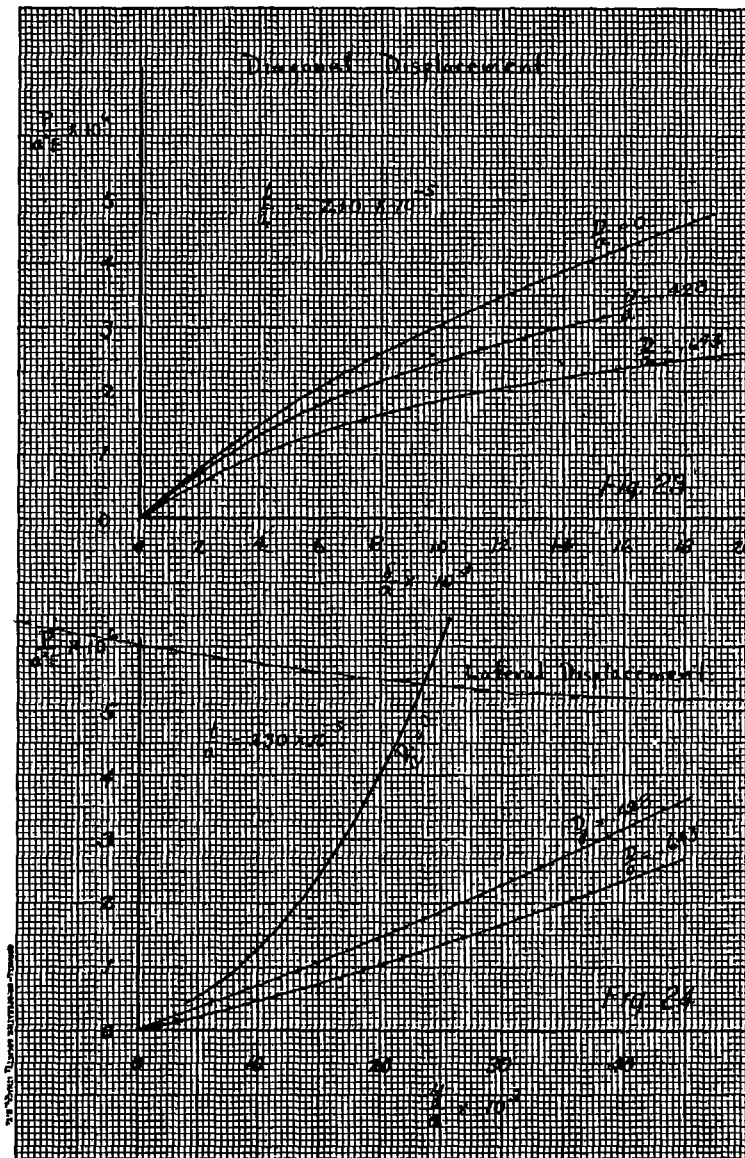
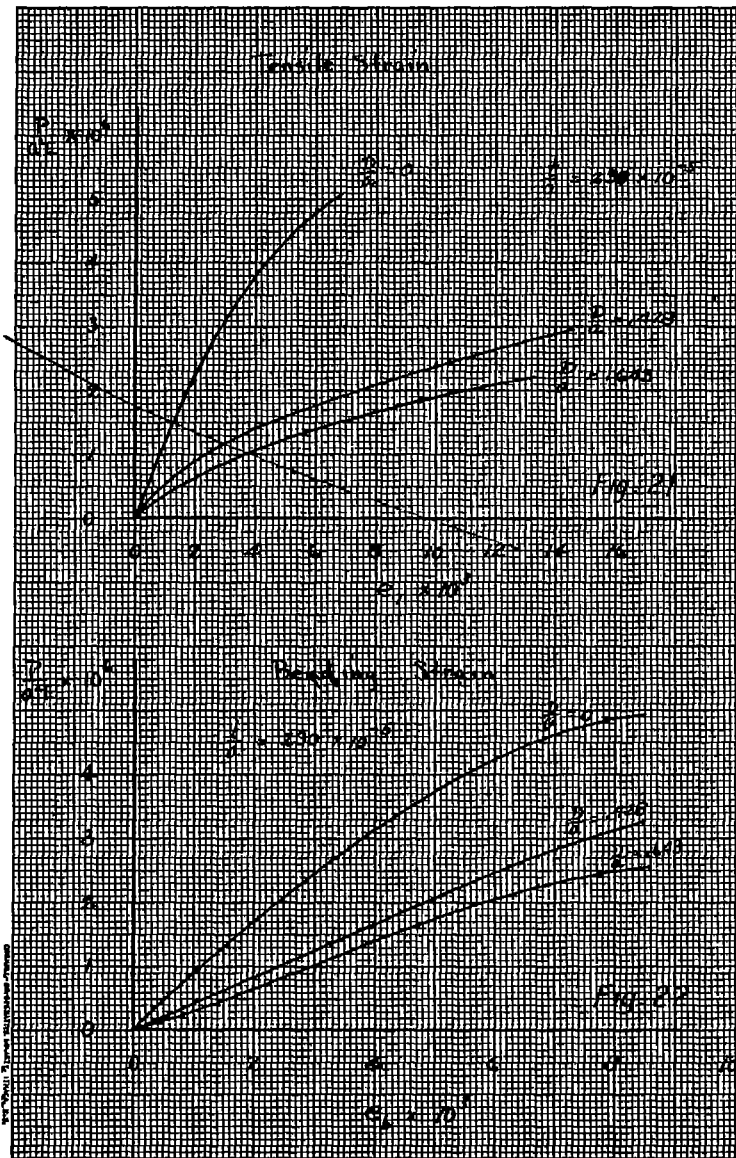
FIG. 11













$a = 17.4''$
 $t = .021''$
 $D = 0$

$t/a = 121 \times 10^{-5}$
 $D/a = 0$

Figure 27.



$a = 28.0''$
 $t = .032''$
 $D = 0$

$t/a = 114 \times 10^{-5}$
 $D/a = 0$

Figure 26.



Laboratory set-up
 17.4" frame

Figure 25.



$a = 17.4''$
 $t = .032''$
 $D = 0$

$t/a = 184$
 $D/a = 0$

Figure 30.



$a = 28.0''$
 $t = .051''$
 $D = 0$

$t/a = 182$
 $D/a = 0$

Figure 29.



Laboratory set-up

28.0" frame

Figure 28.



$a = 8.75''$
 $t = .021''$
 $D = 0$

$t/a = 240 \times 10^{-5}$
 $D/a = 0$

Figure 30.



$a = 28.0''$
 $t = .064''$
 $D = 0$

$t/a = 228 \times 10^{-5}$
 $D/a = 0$

Figure 31.



$a = 8.75''$
 $t = .0315''$
 $D = 0$

$t/a = 360 \times 10^{-5}$
 $D/a = 0$

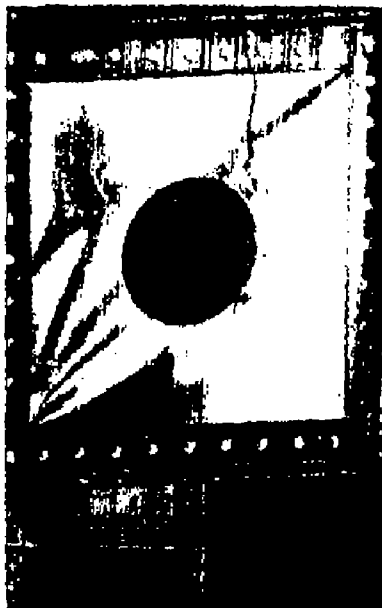
Figure 32.



$$\begin{aligned}a &= 8.75'' \\t &= .0315'' \\D &= 3.75''\end{aligned}$$

$$\begin{aligned}t/a &= 360 \times 10^{-5} \\D/a &= .428\end{aligned}$$

Figure 36.



$$\begin{aligned}a &= 17.4'' \\t &= .0315'' \\D &= 7.45''\end{aligned}$$

$$\begin{aligned}t/a &= 181 \times 10^{-5} \\D/a &= .428\end{aligned}$$

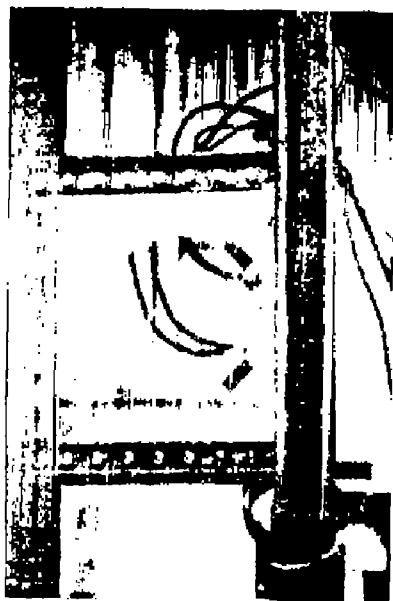
Figure 35.



$$\begin{aligned}a &= 17.4'' \\t &= .040'' \\D &= 7.45''\end{aligned}$$

$$\begin{aligned}t/a &= 230 \times 10^{-5} \\D/a &= .428\end{aligned}$$

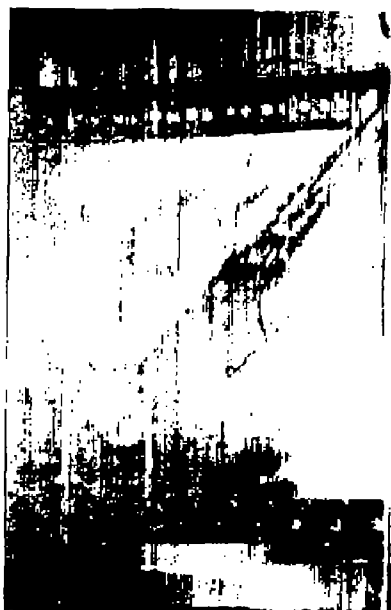
Figure 34.



$$\begin{aligned} a &= 8.75'' \\ t &= .020'' \\ D &= 5.62'' \end{aligned}$$

$$\begin{aligned} t/a &= 228 \times 10^{-5} \\ D/a &= .643 \end{aligned}$$

Figure 39.



$$\begin{aligned} a &= 17.4'' \\ t &= .040'' \\ D &= 11.2'' \end{aligned}$$

$$\begin{aligned} t/a &= 230 \times 10^{-5} \\ D/a &= .643 \end{aligned}$$

Figure 38.



$$\begin{aligned} a &= 28.0'' \\ t &= .064'' \\ D &= 18.0'' \end{aligned}$$

$$\begin{aligned} t/a &= 228 \times 10^{-5} \\ D/a &= .643 \end{aligned}$$

Figure 37.

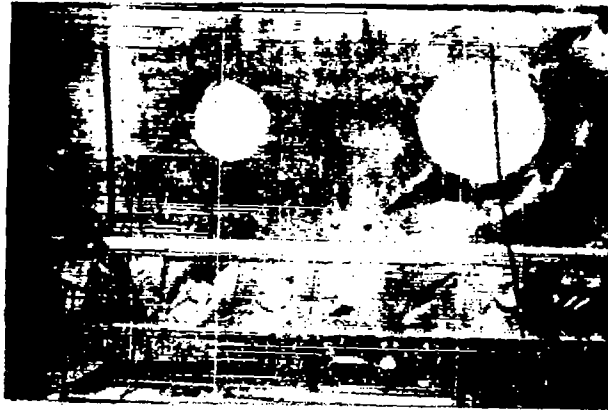


Figure 40.- Tested panels.



Figure 41.- Tested panels.

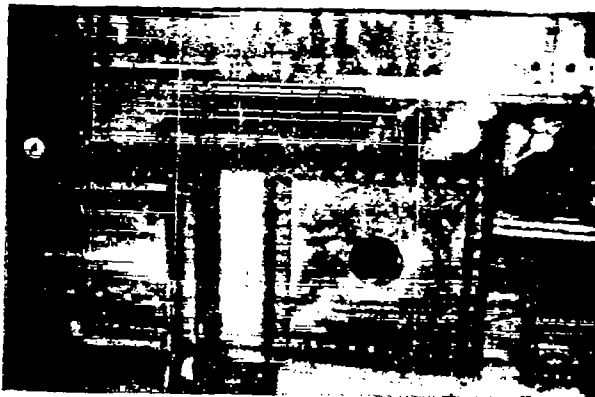


Figure 42.- Relative sizes of frames.

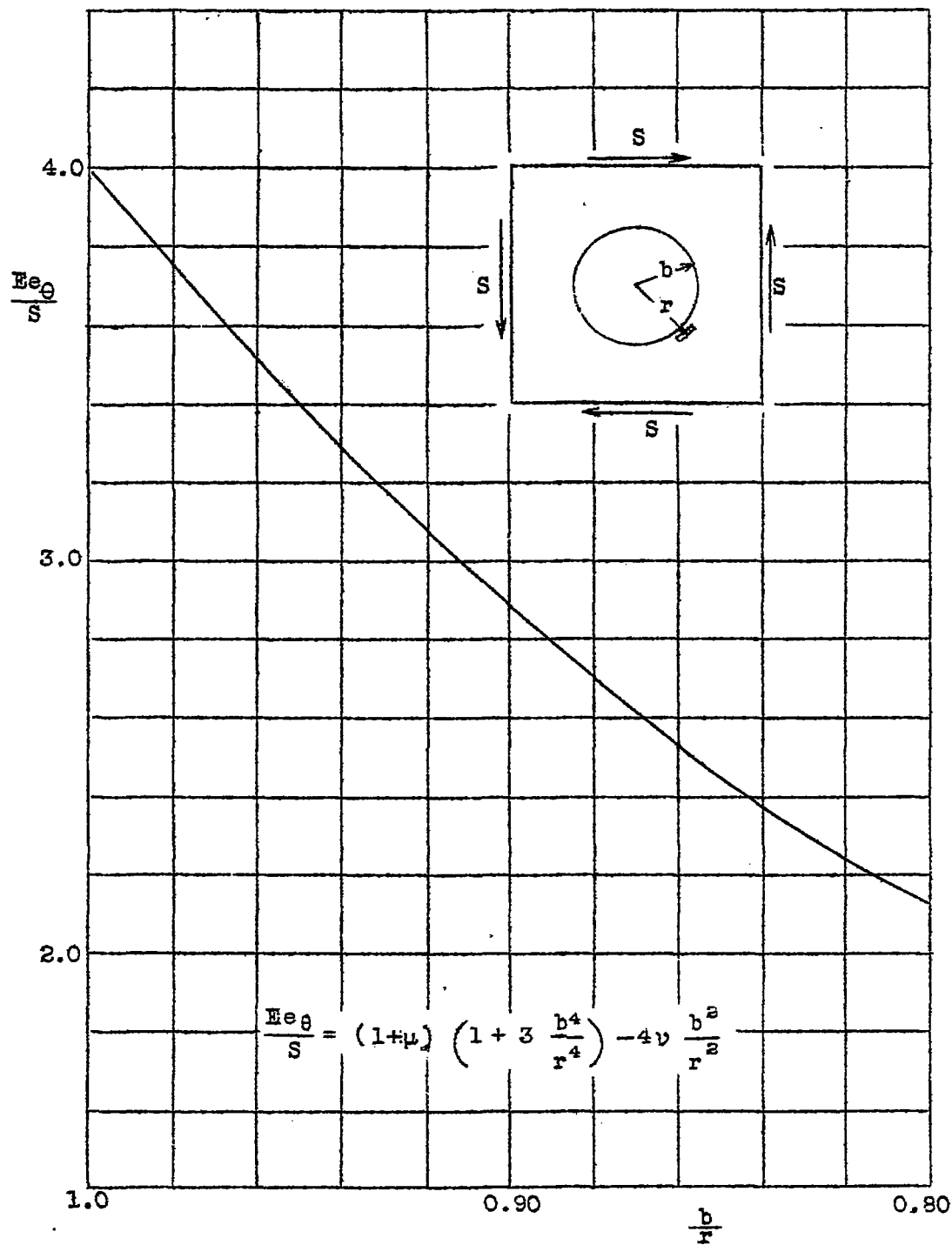


Figure 47.- Strain concentration factor.

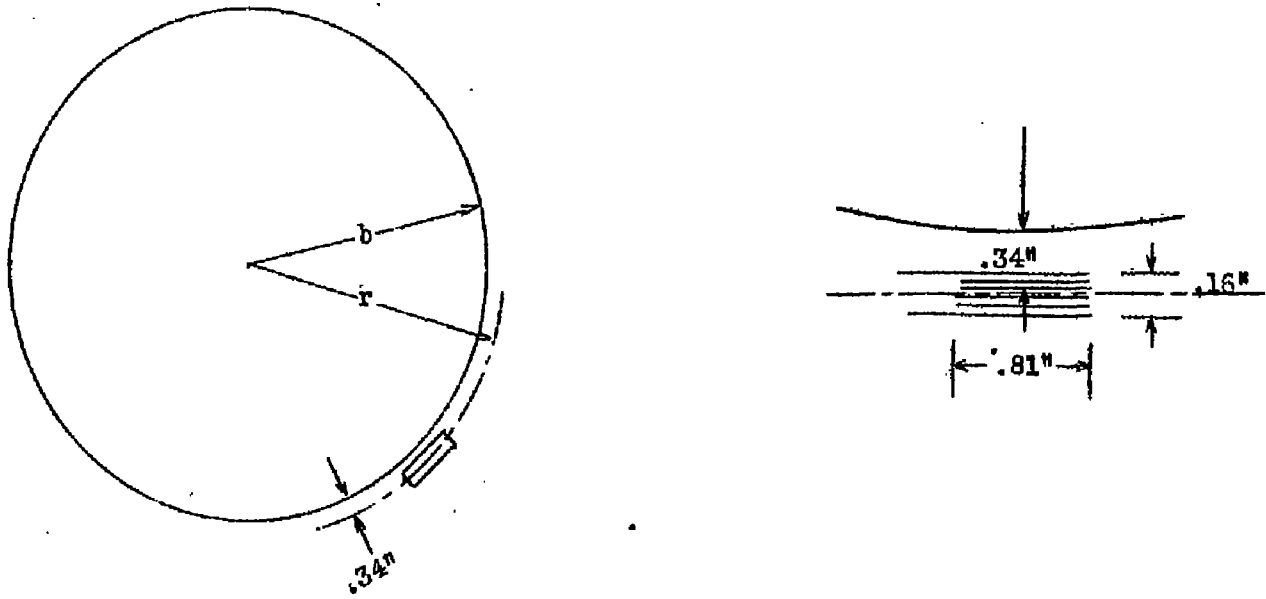


Figure 48.- Electrical strain gage position.

RESTRICTED

TITLE: Applicability of Similarity Principles to Structural Models

ATI- 8054

REVISION

(None)

AUTHOR(S): Goodier, J. N.; Thompson, W. T.

ORIGINATING AGENCY: National Advisory Committee for Aeronautics, Washington, D. C.

ORIG. AGENCY NO.

TN-933

PUBLISHED BY: (Same)

PUBLISHING AGENCY NO.

DATE	DOC. CLASS.	COUNTRY	LANGUAGE	PAGES	ILLUSTRATIONS
July '44	Restr.	U.S.	Eng.	88	photos, tables, diagr, graphs

ABSTRACT:

This is a systematic account of the use of dimensional analysis in constructing similar conditions for models and structures. Analysis covers large deflections, buckling, plastic behavior, and materials with non-linear stress-strain characteristics as well as simpler structural problems. To test validity of similarity principles for structures involving buckling and plastic flow, measurement of strains and displacements were made on square thin sheets in shear with and without holes. With certain exceptions, measurements follow indications of similarity principles.

DISTRIBUTION: Request copies of this report only from Originating Agency

DIVISION: Stress Analysis and Structures (7)

SECTION: Structural Theory and Analysis
Methods (2)

SUBJECT HEADINGS: Structural members - Stress analysis
(90859)

ATI SHEET NO.: R-7-2-15

Air Documents Division, Intelligence Department
Air Materiel Command

AIR TECHNICAL INDEX
RESTRICTED

Wright-Patterson Air Force Base
Dayton, Ohio