

12 10

1

Serial Number 079,729  
Filing Date 28 Sept 1979  
Inventor WILLIAM H. HICKLE

6 Ammunition Separator Tray.

NOTICE

The Government-owned invention described herein is available for licensing. Inquiries and requests for licensing information should be addressed to:

14 PAT-APPL-079 729

U.S. DEPARTMENT OF THE NAVY  
Office of Naval Research  
Assistant Chief for Patents  
Arlington, Virginia 22217

9 Patent Application, \*Filed 28 Sep 79

DDC FILE COPY, ADD 006905

|                    |                                     |
|--------------------|-------------------------------------|
| Accession For      |                                     |
| NTIS GRA&I         | <input checked="" type="checkbox"/> |
| DDC TAB            | <input type="checkbox"/>            |
| Unannounced        | <input type="checkbox"/>            |
| Justification      |                                     |
| By _____           |                                     |
| Distribution/      |                                     |
| Availability Codes |                                     |
| Dist               | Avail and/or special                |
| A                  |                                     |

LEVEL II  
DTIC ELECTE  
S MAR 5 1980 D  
E

DISTRIBUTION STATEMENT A  
Approved for public release;  
Distribution Unlimited

3/18/75

110050 JW

012/KGP:clw  
714-939-3733  
China Lake, CA 93555

Navy Case No. 62446

AMMUNITION SEPARATOR TRAY

ABSTRACT OF THE DISCLOSURE

✓  
5 A tray concept is used to stack rounds of ammunition in layers which alternate in direction. Maximum packing density is achieved through use of separators which are contoured on both sides with altering layering arrangement. The projectile end of the tray cavity is open which allows the contents of the tray to be dumped into ammunition loading equipment. By making the trays of stiff plastic, it is possible to ensure ease in handling for shipboard use.

10 Appropriate materials for fabrication include cellulose acetate butyrate, cellulose acetate, and cellulose acetate propionate. The above compounds avoid corrosive properties commonly experienced in current packing techniques.

80 3 4 051

012/KGP:clw  
714-939-3733  
China Lake, CA 93555

Navy Case No. 62446

AMMUNITION SEPARATOR TRAY

BACKGROUND OF THE INVENTION

Field of the Invention:

This invention pertains to packing devices. In particular,  
it relates to packing devices designed for cartridges and  
5 shells.

Description of the Prior Art:

Present packing techniques consist of cardboard tubes  
placed over each projectile and then placing the rounds  
individually into ammunition containers with the associated  
10 dunnage. All packing and unpacking operations have been  
performed manually and thereby consume both time and space.  
Disposal of the dunnage is difficult and time consuming.  
These factors are undesirable ashore and even more so on  
board ship. It has also been found that the use of cardboard  
15 tubes will include recycled paper which contains sulfur.  
When combined with atmospheric moisture the sulfur containing  
paper creates a corrosive element which attacks cartridge  
cases.

Alternate attempts to secure packing for cartridges  
20 have been shown in U. S. Patent No. 2,750,028 to Bode et  
al. and U. S. Patent No. 2,990,945 to Smith. Both of these

Navy Case No. 62446

prior art patents rely on contoured paper designed to fold over the cartridge and encase it. In addition to the waste problem in removing such packing the use of paper in such devices results in corrosion for reasons described above.

5 Furthermore, while efficiency and packing of adjacent cartridges is claimed in these patents, it is clear that symmetrical arranging of cartridges does not provide maximum packing density.

#### SUMMARY OF THE INVENTION

10 Contoured plastic forms designed to provide alternate layers of cartridges are used to achieve maximum packing density. Each layer of cartridges is thus separated by a single form.

15 The cartridges are stacked in rows alternating direction between the rows. The use of cellulose plastics for the packing separator avoids corrosive properties found in prior art patents utilized previously.

20 The separator can be made of either flexible or stiff plastic. While flexible plastic in general will require less thickness and therefore less weight, a stiff plastic which permits all cartridges to be carried as if on a tray without flexing under the weight is preferred for ease of handling on ships.

Navy Case No. 62446

BRIEF DESCRIPTION OF THE DRAWINGS

Fig. 1 is a figure of a preferred embodiment;

Fig. 2 is a cross section of a preferred embodiment along the line 2-2;

5 Fig. 3 is a cross section along the line 3-3 of the preferred embodiment;

Fig. 4 is a cross section along the line 4-4 of the preferred embodiment;

10 Fig. 5 is a cross section along the line 5-5 of the preferred embodiment;

Fig. 6 is an end on view of the preferred embodiment;

Fig. 7 is an end on view of the preferred embodiment showing hidden lines;

15 Fig. 8 shows the alternate layer arrangement of the Fig. 1 embodiment; and

Fig. 9 shows a maximum density packing arrangement.

DESCRIPTION OF THE PREFERRED EMBODIMENT

20 Fig. 1 shows a possible embodiment of the present invention designed to contain twenty-five rounds of ammunition. The ammunition is arranged in a 13 by 12 alternate layered configuration. For purposes of example, row 10, the twelve shell row, will be an empty bottom layer. Each of oblong shapes 14 are slightly domed plastic configurations in a single

Navy Case No. 62446

sheet which are cupped facing downward. Molded into the same sheet as layer 10 is another row 12 of shapes 14 which are facing upward. Across from each of the shapes 14 is a continuing ridge 16 which is concave upward or downward such that it always forms a peak or valley between adjoining shapes 14 to each side of it. When an ammunition round 18 is placed in one of shapes 14 it will extend over and also partially fill adjoining shape 16 as shown. Making the overall tray 20 a single piece of plastic, such as cellulose acetate butyrate, cellulose acetate or cellulose acetate propionate permits tray 20 to be of sufficient strength to permit it to be carried holding either 12 or 13 rounds depending on which side of tray 20 is upright. It is also easily understood that depending on the thickness of tray 20, tray 20 can either be flexible or rigid. The rigid form can frequently be used to advantage to carry it full of ammunition in less than ideal environments, such as moving ships. The depth of tray 20 should be the minimum needed to hold shells in place. Ammunition loading equipment can handle a tray load at a time. Thus, deep trays, which tend to hold cartridges more securely, would slow the unloading process during periods of combat.

A cross section of tray 20 along cross section 2-2 is shown in Fig. 2. A similar cross section along 3-3 is shown in Fig. 3. As can be seen by the comparison of Figs. 2 and

Navy Case No. 62446

3, the depressions created by sections 14 and 16 alternate with similar shaped elevations 14 and 16 as one goes along center lines 17 shown in Fig. 1. Also shown in Figs. 2 and 3 is thickness 22 of tray 20.

5           In Fig. 3 a characteristic dimension 24 is shown, which represents the effective stacking height of layers of ammunition. As can be clearly seen, height 24 is less than the thickness of the major diameter of an ammunition cartridge. This is possible because the staggered arrangement of rows permits  
10 the narrower diameters of ammunition rounds to overlap. This permits maximum effectiveness in stacking and packing density to be obtained. Such a feature is of significant consequences in ships, tanks or aircraft where the amount of fire power possible is frequently proportional to the  
15 amount of ammunition which can be stored.

Fig. 4 is a cross sectional view of tray 20 along line 4-4.

Fig. 5 is a cross sectional view along line 5-5 of tray 20.

20           Fig. 6 shows a segment of tray 20 shown edgewise. As can be seen, sections 14 and 16 alternate. Peak 16 is slightly higher than the adjoining sections 14. Also shown for comparison is the effective stacking thickness 24.

Navy Case No. 62446

Fig. 7 shows a similar section of an edge on view of tray 20 except that dashed lines show the hidden surfaces representing the overall configuration of alternating sections 14 and 16.

5 Fig. 8 shows two trays 20 alternating with two rows of ammunition rounds 18.

Fig. 9 shows a container in cut-away using the effective stacking of the present invention for multiple rows of ammunition 18. As can be seen, each row of ammunition is separated  
10 by a tray 20. Also shown is the effective stacking distance 24 between trays 20. As can be seen this permits each row of ammunition to average a thickness less than the maximum diameter of each round.

In view of above discussion it is clear that other variations  
15 can be made depending upon the specific nature and shape of the ammunition desired to be packed. It is also clear that such a stacking method can be used for similar shaped items which might not be properly described as ammunition.

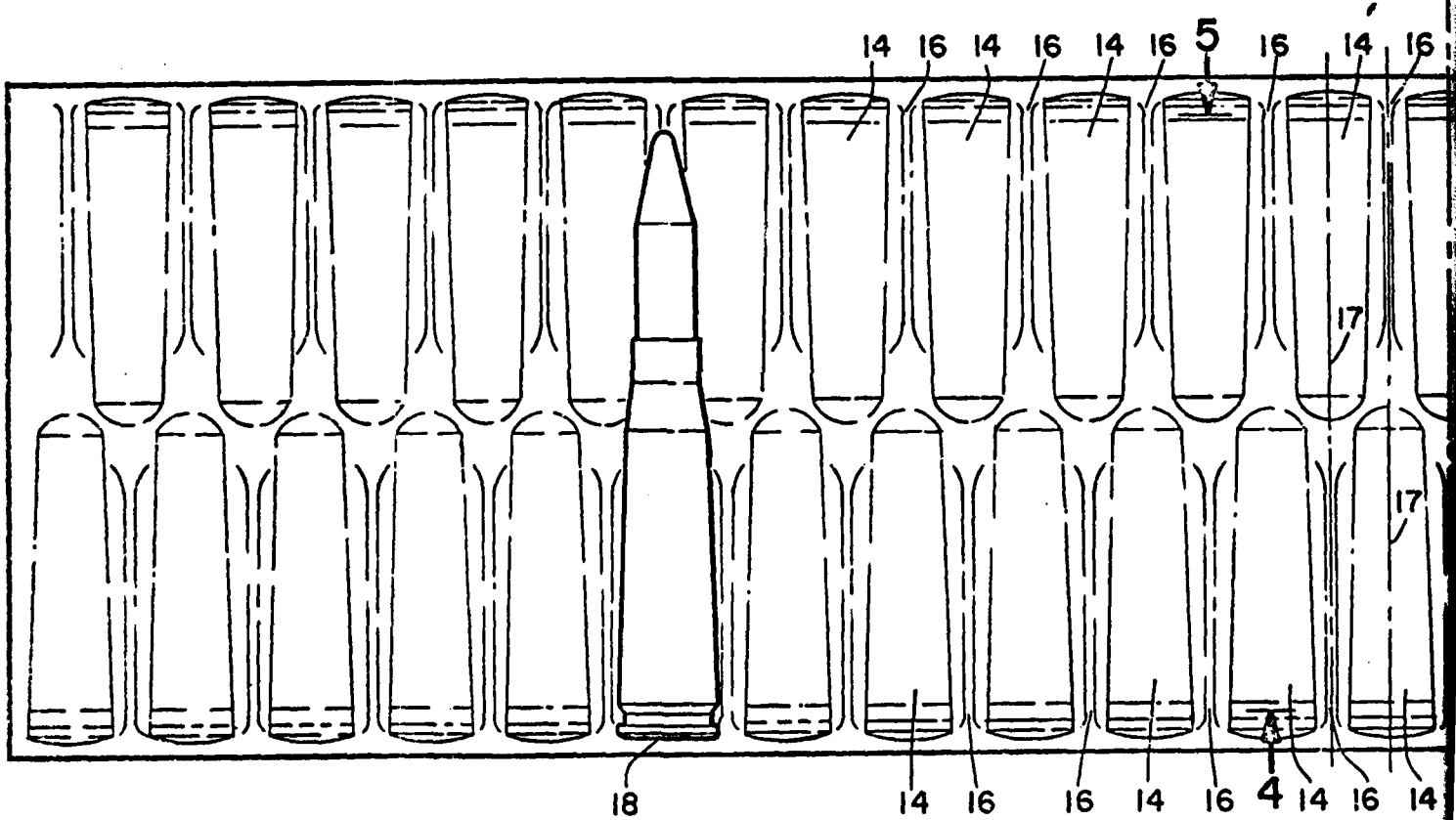

FIG. 1

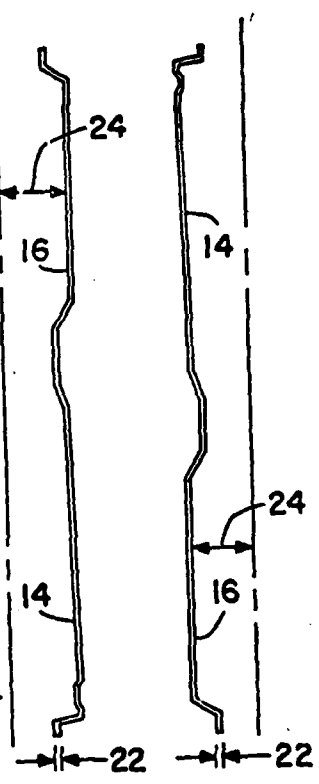
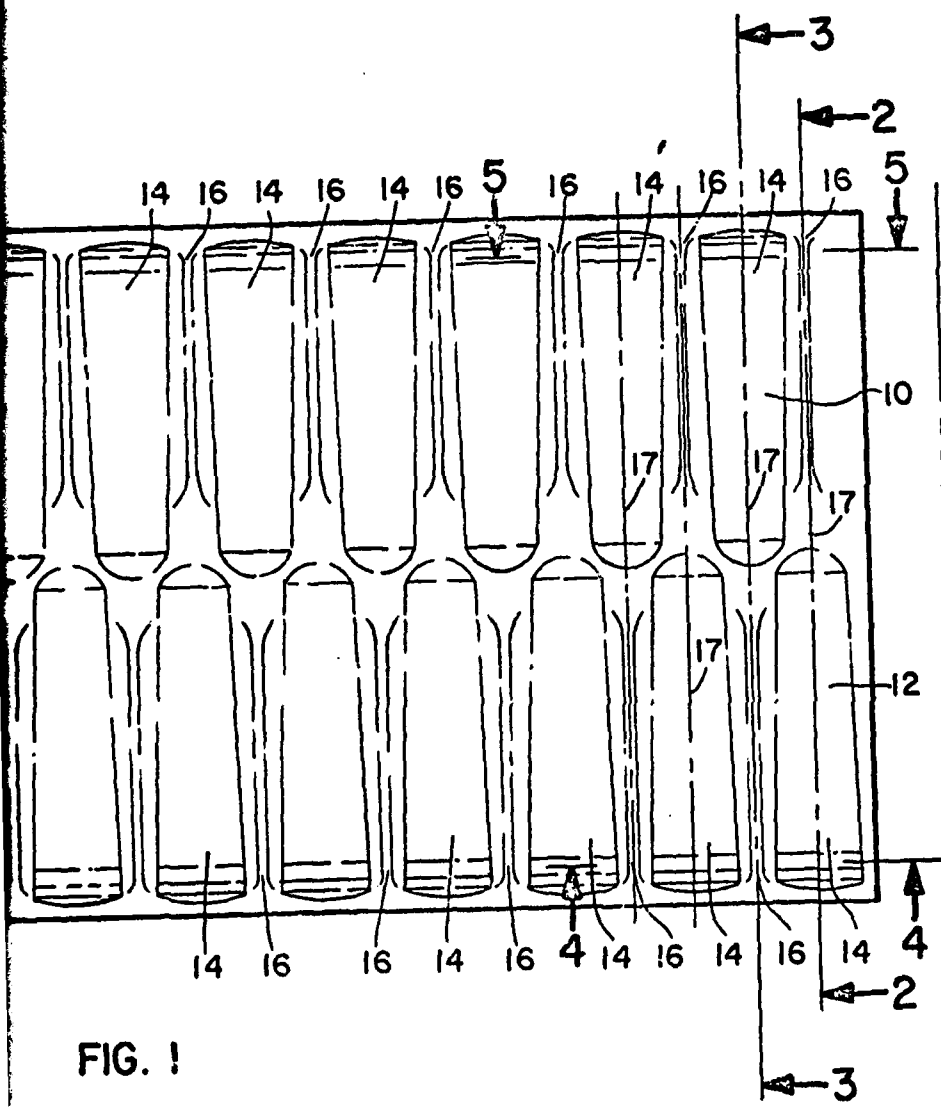

FIG. 2 FIG. 3

FIG. 1

Separated by ...  
 ...  
 ...

2

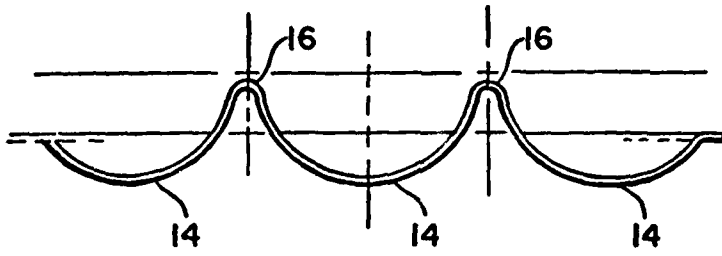

FIG. 4

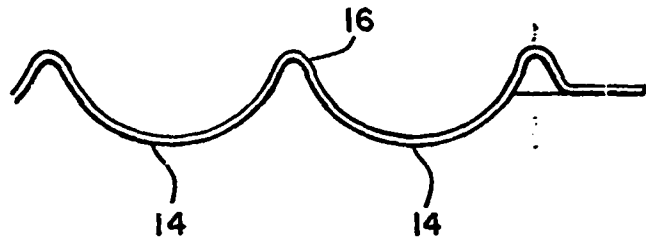

FIG. 5

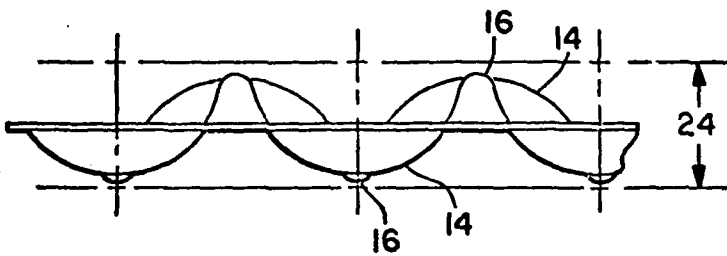

FIG. 6

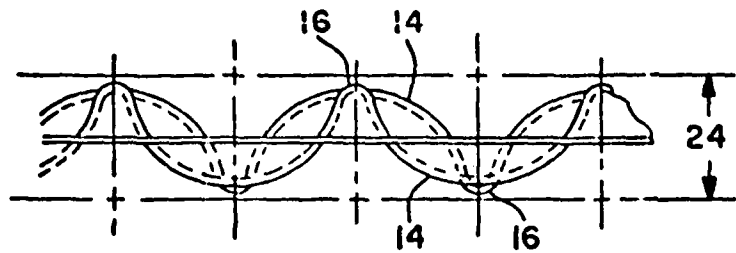

FIG. 7

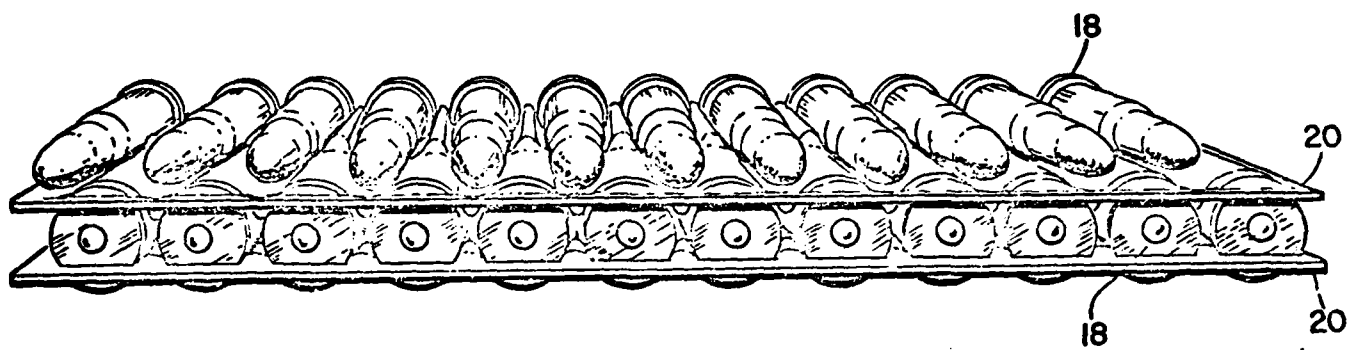

FIG. 8

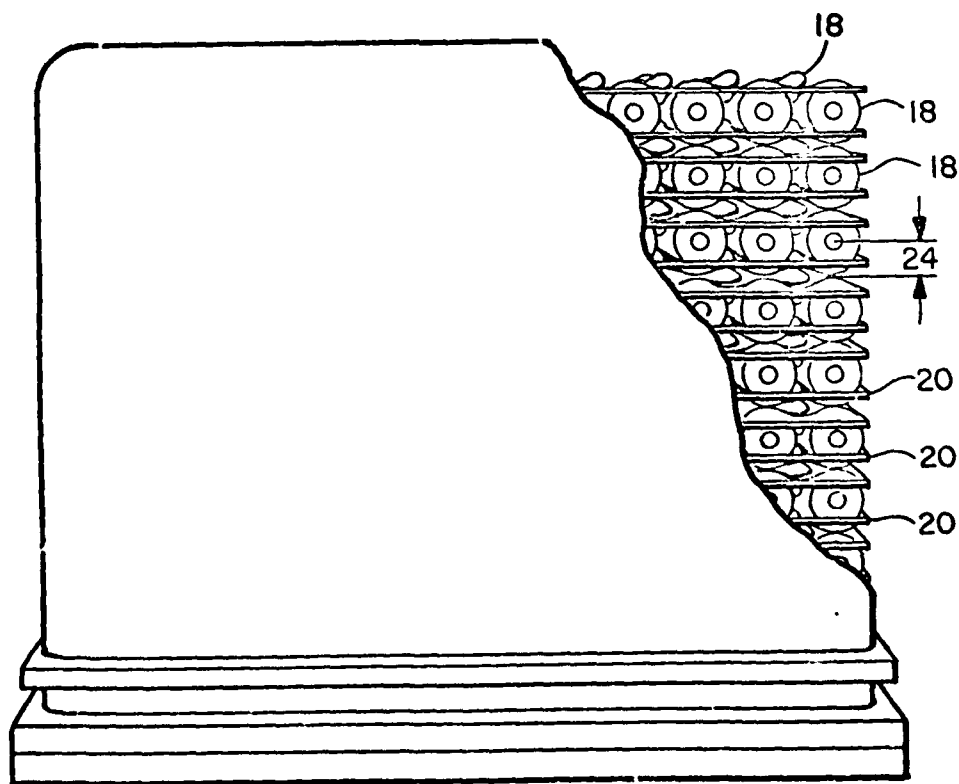

FIG. 9