

①



DEPARTMENT OF THE ARMY
HEADQUARTERS US ARMY COMMUNICATIONS-ELECTRONICS COMMAND
AND FORT MONMOUTH
FORT MONMOUTH, NEW JERSEY 07703

REPLY TO
ATTENTION OF:

24 September 1984

AMSEL-LG-LS

SUBJECT: Patent Applications Available for Licensing
U.S. Serial No. 647,767 filed 6 September 1984
entitled "A Single Optical Fiber Telephone System"
by Nathan W. Feldman
CECOM D-3248

AD D O I I 2 9 3

Defense Technical Information Center
ATTN: DDC-TC
Cameron Station
Alexandria, Virginia 22314

The enclosed patent application is submitted in duplicate
for publication by NTIS as being available for licensing and
publication.

FOR THE COMMANDER:

Michael Zelenka

MICHAEL ZELENKA
Acting Chief, Patent Law Division

DTIC FILE COPY

Enclosure
Application(2)

Copy furnished:
AMC
HQDA (JALS-PC)

Accession For	
NTIS CEAS1	<input checked="" type="checkbox"/>
DTIC TR	<input type="checkbox"/>
Unannounced	<input type="checkbox"/>
Initial Distribution	<input type="checkbox"/>
By _____	
Distribution _____	
Special _____	
Dist _____	
Special _____	

COPIES
INSPECTION

DTIC
ELECTE
OCT 16 1984
S E D

DISTRIBUTION STATEMENT A
Approved for public release;
Distribution Unlimited

A SINGLE OPTICAL FIBER TELEPHONE SYSTEM

The invention described herein may be manufactured, used and licensed by or for the Government for governmental purposes without the payment to me of any royalties thereon.

5

BACKGROUND OF THE INVENTION

This invention relates to communication by means of optical fibers, and more particularly to a novel all optical telephone which is connected to a switchboard or central office by means of a single optical fiber which provides full duplex operation as well as supervisory and dialing functions.

The advantages of communicating by means of modulated light transmitted through optical fibers are well known. For example, an optical system exhibits lower attenuation than a comparable system which transmits modulated electrical signals over a wire or cable system and hence fewer repeaters are required with an optical system. Also, optical systems have significant security advantages which make them highly desirable in military communication systems. For example, optical fibers are difficult to tap, and since they contain no metal and carry no electrical current, they cannot be detected by such things as metal detectors or radar. Also, optical fibers and optical telephones can be made entirely of lightweight, inexpensive plastic. Optical systems are not subject to electrical interference caused by such things as static, sunspots, or the electromagnetic pulse due to nuclear explosions, or jamming signals.

Optical communication systems of various types have been known throughout history; for example the smoke signals of the American Indians, the semaphores of the preceding century which used either flags or illuminated symbols, and the photophones developed by A. G. Bell and his colleagues. The recent advent of light generators in the form of light emitting diodes (LEDs) and laser

30

diodes and the development of thin, lightweight optical fibers has spurred the development of many types of fiber optic communication systems. Such systems in the past have usually utilized the optical fiber as the transmission medium only, with the terminal
5 equipment at both ends of the fiber optic link being conventional electrical or electronic equipment, e.g., electrical telephones or teletypes, etc. Such systems require electro-optic interface units at both ends of the fiber optic link.

All-optical telephones have been developed which use optical
10 fibers for transmission of both intelligence, or voice signals, and supervisory signals as well. These optical telephones contain no electrical components and hence need not contain any metal parts, batteries or electrical contacts. For these reasons such telephones do not present any explosion hazard from electrical
15 sparks in contrast to conventional telephones. Examples of all-optical telephones are found in patent application Serial No. 385,640, entitled OPTICAL TELEPHONE APPARATUS, filed on June 7, 1982, now abandoned. All but one of the optical telephones disclosed in that application utilize two or more optical fibers
20 for communicating with the central office or switchboard. Figure 8 therein shows a single optical fiber telephone which is described on page 26 of the specification. Although not explicitly stated on that page, it is apparent that the single fiber optic telephone of Figure 8 is designed to utilize a single optical wavelength for
25 both the hear and talk modulated light signals which are propagated in opposite directions over the same optical fiber. This is apparent from the sentence starting on line 19 of page 26 wherein it is stated that optical fiber reflection can cause interference. This interference would obviously be crosstalk between the two
30 voice signals travelling in the two directions on the same fiber

and could only be present if only a single wavelength were used for both of the voice traffic signals. The inventor of the cited abandoned application seems to imply in his specification that the single fiber optical telephone is not practical with the
5 then state of the art.

The present invention comprises an all-optical telephone which utilizes a single optical fiber but utilizes two different wavelengths for the two voice or traffic signals. This wavelength multiplexing prevents crosstalk caused by reflections
10 such as occurred with the prior art single telephone described above and also makes it simple to separate the two directions of voice traffic so that the telephone can interface with a conventional telephone system. The optical fiber used is one which exhibits two transmission windows where the attenuation is low
15 and the two optical wavelengths are selected to fall into these two transmission windows.

The novel optical telephone of the present invention can be connected to a conventional electrical or electronic switchboard or central office so that connection can be made to any
20 telephone which can be connected to the central office, be it another optical telephone or a conventional electrical one. Such a hybrid optical-electrical telephone system requires that an opto-electrical interface unit be located at the central office at the end of each single optical fiber which is connected
25 to a remote optical telephone. Other terminal equipment such as an optical teletype may be co-located with the optical telephone and also connected to the single optical fiber.

Opto-electric interface units are two way devices which con-

vert optical traffic or voice signals, as well as supervisory signals, into analogous electrical signals which are compatible with conventional telephone systems, and vice versa. Such devices are known in the prior art and several different types are shown and described in a co-pending application, Serial No. 527,054, entitled, OPTICAL INTERFACE TO AN ELECTRICAL CENTRAL OFFICE, filed on August 29, 1983. All of the interface units described therein are designed for connection to optical telephones which use more than one fiber for connection to the switchboard or central office. The system of the present invention uses a novel opto-electrical interface unit which is especially adapted to interface with the novel single fiber optical telephone described above.

All-optical telephone systems are conceivable, but this would require an all-optical central office or switchboard which is either beyond the state of the present art or would be impractically expensive. Also, the hybrid optical-electrical system of the present invention is the most practical at this time, since it permits connection between all telephones be they optical or electrical. The overwhelming majority of telephones today are of the conventional electrical type.

The single fiber optical telephone of the present invention is analogous to the two wire (or single pair) electrical telephone since in each of these two types of telephones all of the voice and supervisory signals are carried by a single transmission medium. Thus the present invention represents the ultimate simplification of a fiber optical telephone system.

It is thus an object of the invention to provide an all-optical telephone which is adapted for use with a single optical fiber which carries the two directions voice traffic signals as modulated light at two different wavelengths.

Another object of the invention is to provide an all-optical telephone system comprising an optical telephone which is connected by a single optical fiber to an opto-electrical interface unit located at a conventional telephone central office, said fiber
5 having two transmission windows, said interface unit comprising means to convert the voice and supervisory signals on said single fiber to electrical signals useable with conventional electric telephones which are also connected to said central office, and said interface unit also comprising two light generators for
10 supplying unmodulated light at the wavelengths of said two transmission windows of said optical fiber.

A further object of the invention is to provide an all-optical telephone which comprises means to receive on a single optical fiber voice traffic on a first wavelength and to direct said
15 received voice traffic to an opto-acoustic transducer which comprises the earphone of the telephone, and means to receive unmodulated light on said single fiber at a second wavelength, a microphone means to modulate said unmodulated light in accordance with sound waves applied to said microphone means, and means to
20 apply the modulated output of said microphone means to said single fiber, and wherein said optical fiber is chosen with two transmission windows at said first and second wavelengths.

Another object of the invention is to provide an optical telephone system which provides full duplex operation on a single
25 optical fiber by multiplexing the voice and supervisory signals on said single optical fiber at two different wavelengths.

SUMMARY OF THE INVENTION

The invention comprises an all-optical telephone which need not contain any metallic parts and does not utilize electricity,
30 electrical conductors or contacts and is adapted to be connected

to a central office or switchboard by means of a single optical fiber which carries both directions of traffic as modulated light at two different wavelengths, with the single optical fiber chosen to have transmission windows at said two different wavelengths.

5 The supervisory and ringing signals are also appropriately multiplexed onto the single fiber at one or the other of the two wavelengths.

The invention also comprises an optical telephone system comprising the aforementioned optical telephone combined with
 10 an opto-electric interface unit which is located at a conventional electrical central office or switchboard, the said interface unit comprising means for converting optical signals received from said optical telephone on the single optical fiber to analogous electrical signals and also converting electrical signals
 15 from other telephones and from said central office to analogous optical signals which are applied to said single optical fiber for transmission to the remote optical telephone. Thus analog electrical signals are converted to analog optical signals and digital electrical signals to digital optical signals, and vice
 20 versa.

A still^l further feature of the present invention comprises a hybrid telephone system composed of optical telephones of the type described as well as conventional electrical telephones, the optical telephones being connected to a conventional
 25 electrical central office or switchboard by means of a single optical fiber with double transmission windows, each of the single fiber optical telephone lines being terminated ~~at~~ by an opto-^{must} electrical interface unit located at the central office. The interface units convert the optical signals on each of the fiber
 30 optic lines to electrical signals compatible with said electrical telephones and also convert electrical telephone signals received

NY 10/12/84
10/12/84

from said central office to optical signals which are transmitted over said fiber optic lines to the optical telephones.

The invention also comprises a novel opto-electrical interface unit which is useful in connecting single optical fiber telephone lines with wavelength multiplexed signals thereon to conventional electrical telephone switchboards or central offices.

BRIEF DESCRIPTION OF THE DRAWINGS

Figure 1 is a block diagram of the hybrid telephone system of the present invention.

10 Figure 2 is a diagram of the novel optical telephone system of the present invention.

Figures 3 and 4 show an illustrative hook switch which may be used with the optical telephone of Figure 2.

15 Figure 5 shows one type of microphone or acousto-optic converter which may be part of the optical telephone of this invention.

Figure 6 is a graph illustrating the operation of the microphone of Figure 5.

20 Figure 7 shows one type of earphone or hear mechanism which may be part of the handset of the optical telephone shown in Figure 2.

DETAILED DESCRIPTION OF A PREFERRED EMBODIMENT

Conventional electrical telephone systems comprise a central office or switchboard with each of the connected telephones linked thereto by means of a single pair of wires. The wire pair comprises only a single transmission path since the current in each wire is the same. Both directions of voice traffic as well as all necessary supervisory signals are carried on the single metallic pair. This is known as full duplex operation. The use of electrical hybrids at central offices permits the two directions

of voice or other signals on the single pair to be separated based on their different directions of flow. At the present state of the art, no practical optical analog exists for the electrical hybrid and hence the optical telephone system of the present invention uses multiplexing techniques to separate the two directions of traffic on the single optical fiber. The recent development of optical fibers with at least two transmission windows substantially separated in wavelength has made this wavelength multiplexing possible. At each of these windows the attenuation of the optical fiber is sufficiently low to permit the use of fiber lines several kilometers long with the use of only moderate amounts of optical power and state of the art acousto-optical, and opto-acoustic converters at the optical telephone and at the interface units.

The hybrid telephone system of Figure 1 permits one or more optical telephones (OPT), 17, to be interconnected with a conventional electrical central office or switchboard 9, so that any one of the connected telephones, be they optical or electrical, may communicate with any other telephone. Each of the single optical fibers 15 connected to an optical telephone terminates in an optical-electrical interface unit 13, which is co-located with the central office 9 and serves to convert all signals on the single optical fibers to compatible two wire electrical signals which can be processed by the conventional central office. The metallic pairs connecting the interface units to the central office are indicated by the numeral 14. The conventional telephones (ETP) are indicated at 21, with the metallic pairs thereof 19 connecting these telephones to the central office. With this arrangement the optical telephones appear to the switchboard or central office to be conventional telephones.

The optical telephone system comprising the elements 13, 14, 15 and 17 of Figure 1 may be implemented with apparatus such as that shown in Figure 2, wherein the same reference numerals are used to designate the major components. The optical telephone
5 of the present invention comprises the components within the dashed-line box 17, and the opto-electric interface unit the components within the box 13. The two components being connected by the single optical fiber 15 as in Figure 1.

The optical telephone system comprises, at the interface
10 unit, a pair of light generators which produce steady or dc light at the two wavelengths at which the system operates. This light may be coherent light produced for example by injection laser diodes or it may be non-coherent light produced for example by light emitting diodes. The output of the first of these generators
15 is applied to an electro-optical modulator, which is a device for converting electrical analog signals, for example telephone voice signals, to modulated light signals for transmission to the optical telephone. The voice modulated optical signal will comprise the output of the aforementioned first light generator modulated by
20 the voice signal to be transmitted to the remote optical telephone. The output of the second of the light generators at the interface unit is multiplexed onto the single optical fiber as a steady or dc light signal which is transmitted to the remote optical telephone where it is applied to the telephone's microphone where it
25 is amplitude modulated by the sound waves spoken into the microphone by the telephone's user. The modulated light from the microphone, which is at the wavelength of the second light generator, is then sent to the interface unit along the fiber where it is converted to analog electrical signals which can be applied
30 to the electrical telephone system comprising the central office and all connected electrical equipment. Supervisory and ringing

signals are also provided for. For example electrical ringing signals comprising the standard 20 Hz tone of the conventional telephone systems will pass through the interface unit from the adjacent central office and will be converted to an equivalent modulated light signal therein. The hook switch of the optical telephone when in the on-hook position will direct this ringing signal to the telephone's ringer.

At the optical telephone, when the handset is off-hook, the incoming light signals comprising the modulated traffic at the wavelength of the aforementioned first light generator as well as the steady light output of the aforementioned second light generator are applied to a dichroic filter which will separate these two light signals based on their different wavelengths, and the incoming modulated traffic signal will be directed to the earphone of the telephone. This earphone comprises an opto-acoustic converter or hear device which can directly convert audio modulated optical signals to acoustic signals which can be heard by the telephone user. The dichroic filter directs the unmodulated light from the second light generator to the microphone where it is modulated by the user's voice, as explained above.

The telephone also includes a dialing capability comprising a conventional rotary dial arranged to make and break the optical fiber connection between the aforementioned microphone and the directional coupler which applies the microphone's output to the single optical fiber. The light dialing pulses are then transmitted to the interface unit where they are converted to identical electrical pulses which are applied to the central office for switching purposes.

Referring now to Figure 2, the optical telephone 17 comprises a hook switch 35 which has three optical fibers 15, 36 and 37 con-

5 nected thereto, all of which have similar characteristics. The
fiber 15 is the transmission fiber which connects the telephone
to the interface unit 13 located adjacent to the electrical central
office. When the telephone is "on-hook", the weight of the hand-
set resting on its cradle which is part of the telephone's base
will depress the hook switch and thereby connect the optical
fiber 15 to the fiber 37 which is connected to ringer 39. Ringer
39 is an opto-acoustic converter which converts optical ringing
signals from the central office to an audible tone which alerts
10 persons in the vicinity of the telephone that a call is waiting
to be answered. The structure of the ringer 39 may be similar to
that of the earphone 25 which will be described in detail in con-
nection with Figure 6. When the handset is lifted, the hook
switch connects the fiber 15 to the fiber 36 and disconnects the
15 fiber 37 therefrom. The output of the aforementioned second light
generator at the interface unit will then be applied to fiber 36
which passes through optical directional coupler 33 and thence to
dichroic filter 29 via fiber 32. The dichroic filter is arranged
to direct the wavelength of the aforementioned second light
20 generator to the microphone 53 via fiber 47 where it is modulated
by voice signals applied thereto by the user. The modulated
light signals at the second wavelength (or that of the second light
generator) are then applied to optical fiber 49 and thence to a
special form of an optical directional coupler 45 which bleeds
25 off a small percentage of the outgoing modulated voice signal as
a sidetone, and applies it to the earphone 25 via optical fiber 31
and directional coupler 27. The directional coupler 45, for
example may bleed off 10% of the output of microphone 53 and use
it for sidetone. The outgoing voice signal is then applied to
30 rotary dialing device 43 which is the optical equivalent of a

conventional electrical telephone dialer in that it is closed while idle and when operating it opens and closes at a fixed rate to produce optical dialing pulses. The outgoing voice signals pass through the closed dialer 43 and are applied to optical directional coupler 33 via fiber 41. As indicated by the curvature of fiber 41 as it is connected to the directional coupler this device directs the outgoing voice and dialing pulses to the fiber 15 through the hook switch which is in its "off-hook" position. The dichroic filter 29 also directs the incoming modulated voice traffic at the wavelength of the first light generator to earphone 25 via directional coupler 27 and optical fiber 26.

In the interface unit 13, components to the left of the vertical dashed line 84 are optical and those to the right thereof are electrical with the electro-optical components straddling the line, except for ring generator 20 and metallic pair 18. The incoming voice traffic and supervisory signals from fiber 15 are applied to directional coupler 57. These signals pass through this component with little attenuation and are applied to dichroic filter 61 which is similar to the filter 29 of the telephone 17. The voice signals at the wavelength of the second light generator 85 plus any supervisory signals at this wavelength are directed from filter 61 via fiber 63 to opto-electrical converter 65, which converts these optical signals to electrical signals. This can easily be achieved by means of a photodetector or the like. The electrical voice signals are then amplified by amplifier 66 and applied to one input 76 of the electrical hybrid 73. These received signals are then transmitted to the central office 9 via the metallic pair 14. The dialing pulses from the telephones follow the same path as the incoming voice traffic.

The off-hook detector 81 detects any dc or voice signals in

the output of converter 65 and operates closure generator 79 in
 response thereto. When the optical telephone user goes "off-hook",
 the output of the second light generator is applied to the micro-
 phone 53, as previously explained, and even in the absence of any
 5 acoustic or voice waves spoken into the microphone, a portion of
 the steady light from the interface unit will appear in the micro-
 phone output and be transmitted back to the interface unit. This
 supervisory signal indicates that the user ^{is} ~~is~~ ^{about to dial.} ~~is~~ ^{off-hook" and perhaps} ~~is~~ ^{the} ~~is~~ ^{hook}
 closure generator may comprise for example, a relay, the points of
 10 which bridge the metallic pair 14 with a choke so that voice
 frequencies are not shorted out. This bridging will draw dc
 current from a battery in the central office which will provide
 an indication of the off-hook condition at the optical telephone.
 The unmodulated light output of the second light generator 55 is
 15 applied to optical fiber 15 via fiber 86 and directional coupler
 57.

Voice and other traffic, for example data or video traffic
 for transmission to the optical telephone flows from the central
 office over metallic pair 14 to hybrid 73 which applies it from
 20 hybrid output 78 to limiter 71 and amplifier 69, in cascade, as
 shown, and thence to the input of electro-optical converter 67,
 wherein the electrical traffic and supervisory signals from the
 central office are converted to equivalent or analogous optical
 signals. The output of the first light generator 87, which is at
 25 a first wavelength corresponding to one of the transmission windows
 of the optical fibers used in this system, is applied to converter
 67 and this steady light is converted therein into an amplitude
 modulated light signal which is applied to directional coupler 57
 via optical fiber 68. The mode of operation of converter 67 can
 30 be similar to that of microphone 53 which will be explained in

connection with Figure 5, except that the moving diaphragm can be moved by means of an electrically driven coil which functions like the voice coil of a speaker.

5 The ringing signals from the central office are too powerful
to pass through the converter 67, and the limiter 71 prevents these
high power signals from reaching converter 67. The ringing signals
from the central office are applied to the interface unit via
metallic pair 14 and are detected by ring detector and sender 52
10 which applies an electrical signal onto metallic pair 18 in response
thereto. The electro-optic ring generator 20 is connected as shown
to the output of directional coupler 57 and to metallic pair 18 and
this device generates optical ringing pulses on optical fiber 15,
for example by making and breaking the steady light output of the
second light generator, in response to the electrical signals
15 applied thereto over metallic pair 18. The ring generator 20 is
closed in its idle condition so that all the other optical signals
can pass therethrough.

The electrical components of the interface unit are powered
by means of power supply 83 which is connected to the various
20 electrical components therein via leads 89 and 91, and the leads
branching therefrom. The element 74 connected to hybrid 73 is an
impedance matching termination.

As indicated by the curvature of the optical fibers 68 and 86
at the directional coupler 57, the light from the converter 67 and
25 the second light generator 85, are directionally applied to fiber
15 for transmission to the optical telephone. The straight
through connection of fiber 59 to filter 61 means that all incoming
light from fiber 15 is applied to filter 61.

30 The hook switch 35 of the optical telephone 17 may comprise
a simple mechanical device which lines up the optical fiber 15

to the tube 101 by several screws such as 105. The optical fiber 47, which carries unmodulated light from the dichroic filter 29 of the telephone 17 to microphone 53 thereof, passes through the ring 102 and is attached thereto by a bonding agent 107 which may
5 be epoxy. The fiber 47 then runs radially inward across diaphragm 103 and is bonded to the diaphragm near its center by the binding agent 107. The output or fixed fiber 49 is mounted in confronting relation to the end of fiber 47 by means of a thin tube 106
10 radially mounted along the surface of the diaphragm from a point diametrically opposite from that where the fiber 47 passes through ring 102. The fixed tube 106 may be the point of ^ahypodermic ^{W.H.F.} ^{9/30/64} needle with the fiber 49 inserted therein. The tube is fixed in place by bonding agent 107 which attaches it to ring 102. The diaphragm 103 may be mylar plastic. In the idle condition the
15 two confronting fibers are offset slightly so that a portion of the dc light passes through the microphone. This is necessary to prevent distortion of the voice signal which would occur if the fibers were perfectly aligned in the idle condition. This is illustrated by the graph of Figure 6, which shows as the ordinate
20 the amount of light transferred between the confronting fibers as a function of the amount of offset between the fiber centers. Zero offset or perfect alignment is represented by the abscissa of 0. In order to avoid distortion in the output modulated light represented by the sine wave 119, the fibers are offset slightly
25 in the idle state so that the voice signal 125 which vibrates the diaphragm and the input fiber 47 is not of sufficient amplitude to bring the fibers to the aligned position of "0". In the graph the fibers are misaligned to the right by 20 microns in the idle state and the amplitude of input vibration is 10 microns so that
30 the diaphragm and input fiber move between 10 and 30 microns

positive amplitude to produce the undistorted output modulated light signal 119.

The electro-optical converter 67 of the interface unit 13 of Figure 2 may comprise a pair of confronting optical fibers like those of the microphone of Figure 5, however the moveable fiber such as 47 would not be attached to a diaphragm but would be connected to and be driven by an electro-mechanical transducer such as piezoelectric crystal or an electrical coil similar to a speaker voice coil. The electrical signal to be converted would be applied to the electrical coil or crystal and would cause the moveable coil or crystal to move in synchronism with the analog electrical signal. The stationary fiber would then produce a modulated light signal just as does the microphone of Figure 5.

The earphone 25 of the present optical converter, developed by S. Edelman, comprises an absorptive optical fiber network which branches off from the fiber which carries the modulated optical signal to be converted. The absorptive fibers are of the type which can expand and contract efficiently at audio frequencies in proportion to the light energy absorbed thereby. The absorptive fibers are acoustically matched to a diaphragm to produce the sound output. The fibers must have a large Young's modulus, a high coefficient of thermal expansion, and a low specific heat.

Another device which can be used as the earphone was built by Kleinman and Nelson of the Bell Telephone Laboratories and is known as a photophone. Such a photophone is shown in Figure 7. It comprises a small chamber 111 which is filled with an optically absorptive material 113, which may be carbonized cotton fiber. A photo-acoustic effect takes place when light interacts with absorptive material of this type. The absorption raises the material's temperature to a level which depends on its absorption

coefficient, thermal conduction and the convection and radiation
 processes in the chamber 113. The carbonized cotton suspended in
 air in the small chamber may be regarded as a pseudo gas and if
 the chamber dimensions are small compared to the smallest acoustic
 5 wavelength of interest, modulated light applied to the chamber,
 for example from optical fiber 26, which terminates at the entrance
 to chamber 113, will be converted therein to acoustic waves. The
 small chamber which has a volume of approximately one cubic milli-
 meter has a high acoustic impedance which produces sound waves
 10 of high pressure and low flow. This high acoustic impedance must
 be transformed to a lower impedance if the sound is to be effi-
 ciently applied to the much larger volume of the external human ear.
 This acoustic impedance transformer may comprise a ~~long~~ tapered ^{mu-9} tube, for example an exponential horn such as 115 of Figure 7,
 15 with its small end opening into chamber 113 and its large end
 being terminated by earpiece 117 which is adapted to fit against
 the user's ear. With modifications, a device of this type can be
 used as the ringer 39 of the present optical telephone. For
 example, if the ringing signal is at the standard 20 Hz rate, the
 20 tapered horn should be designed to encourage spurious or harmonic
 sound waves at overtones of the 20 Hz signal. These overtones will
 be within the audible range. Instead of carbonized cotton fibers,
 the earphone may utilize dark colored metal filings or ^{other} fibers. ^{mu-9}
 The earphone or photophone of Figure 7 is similar to ^{that} ~~these~~ ^{mu-9}
 25 shown in Figure 4A and 4B of the aforementioned abandoned patent
 application. The exponential horn 115 will normally be 20-30 cm
 in length and would thus be too long to fit into a telephone hand-
 set, however the horn can be folded or coiled to accommodate the
 space available in a typical handset.

The mode of operation of the telephone systems of Figures 1 and 2 will now be summarized. In the idle condition the hook switch is "on-hook" so that the transmission fiber 15 is
5 connected to the ringer 39 which is awaiting a ringing signal. The interface unit is constantly sending to the telephone 17 the steady output of the second light generator 85 at the second wavelength through directional coupler 57 and fiber 15. When the user lifts the handset preparatory to dialing, the hook switch
10 transfers the connectivity of fiber 15 to fiber 36 and the steady light signal on fiber 15 is applied to the microphone 53 via fiber 36, directional coupler 33, fiber 32, filter 29 and fiber 47. A portion of this steady light signal passes through the microphone to its output fiber 49, through directional coupler 45
15 and then to dialer 43. Prior to dialing, this steady light signal is sent back to the interface unit via fiber 41, directional coupler 33, fiber 36, the hook switch and fiber 15, where it is detected by "off-hook" detector 81 which notifies the central office via closure generator 79 that the user is off-hook
20 and should soon be dialing. On receiving a dial tone from the central office, the user dials the desired number and dialer 43 will produce a series of dialing pulses having the carrier frequency of the second wavelength, which pulses will be sent to the interface unit 13 via fiber 41, directional coupler 33, fiber
25 36, the hook switch 35, and fiber 15. At the interface unit, the dialing pulses pass through directional coupler 57 to converter 65 where they are converted to a train of electrical pulses which are applied to the "off-hook" detector 81, the closure generator 79, and metallic pair 77, which connects to metallic pair 14 for
30 connection to the central office. At the central office the dialing pulses perform a switching function which connects the remote called telephone to the metallic pair 14, and the

conversation proceeds. The user's voice waves at the telephone 17 are converted into modulated optical waves as explained above, and sent to the interface unit 13 via fiber 41, directional coupler 33, fiber 35, and fiber 15. At the interface unit, the modulated light passes through the directional coupler 57 to converter 65 where it is converted to electrical energy and applied to input 76 of the hybrid circuit 73 for connection to metallic pair 14 and connection to the central office. The dialer 43, when idle during the conversation, will be closed so that the voice signals can pass through it. Voice traffic from the remote connected telephone will pass through it. Voice traffic from the remote connected telephone will pass through the central office and to the interface unit via metallic pair 14, thence through the hybrid 73, limiter 71, and amplifier 69 to converter 67 where it is converted to a modulated light signal at the first wavelength of the first light generator 87. This modulated light signal is then sent to the optical telephone 17 via fiber 68, directional coupler 57 and fiber 15. It passes through the hook switch to fiber 36, directional coupler 33, fiber 32, filter 29, directional coupler 27 and fiber 26 to earphone 25. When the user goes on-hook at the end of the conversation, the initial idle condition is restored.

If a remote telephone user wishes to converse with someone at telephone 17, the central office will transmit the ringing signal over metallic pair 14 and this will be applied to ring detector and sender 52, metallic pair 18, ring generator 20, fiber 15, hook switch 35 and fiber 37 to ringer 39 which will operate in response to the received ringing signal. When the telephone is answered the hook switch will disconnect the ringer from the fiber 15 and connect the microphone and earphone thereto, as previously explained.

Commercially available optical fibers have transmission windows at 850 and 1300 nanometers (nm), with attenuation in

the order of 3.0 dB/km at the shorter wavelength and 1.0 dB/km at the longer wavelength. Dichroic filters designed for these wavelengths can provide 35 dB of separation. Also, the literature indicates that optical directional couplers of the type used in the present invention can provide 25 dB of separation. Nelson and Kleinman have reported that their photophone will produce the required sound power level (SPL) of 81 dB with a modulated optical power input of 2 milliwatts (or 2.8 dBm). Thus, for example, an optical telephone system like that of Figure 2, using the aforementioned commercially available fiber, and with the first light generator 87 selected to generate light in the 1300 nm wavelength region, and with a fiber optic link 15, 5 km in length, and coupling losses of 5.0 dB in addition to the fiber optic link attenuation, the electro-optical converter 67 at the interface unit must have a modulated optical power output of plus 12.8 dBm, or approximately 20 milliwatts to deliver a sound level of 81 db at the end of the 5 km line.

The energy budget for the talk direction depends on the sensitivity of the opto-electrical converter 65 of the interface unit. Using a converter having a sensitivity of minus 40.0 dBm, and allowing a 10.0 dB safety factor, the received optical modulated light signal at the interface unit is minus 30.0 dBm. With the second light generator 85 generating light at the second transmission window in the 850 nm region, the required output of generator 85 would be plus 10.0 dBm of unmodulated light energy, which, at microphone 50 would be minus 10.0 dBm. At different lengths of optical fiber, the received power levels would be different.

While the invention has been described in connection with illustrative embodiments, obvious variations therein will be apparent to those skilled in the art, without departing from the spirit of this invention, accordingly the invention should be limited only by the scope of the appended claims.

A SINGLE OPTICAL FIBER TELEPHONE SYSTEM

ABSTRACT

A hybrid telephone system comprising a plurality of optical telephones and a plurality of electrical telephones all connected to a conventional central office. The optical telephones are all provided with opto-electrical interface units co-located with the central office, for converting optical signals received from the optical telephones to electrical telephone signals, and for converting electrical telephone signals from said central office to optical signals for transmission to the optical telephones. The optical telephones are connected to the interface units by means of a single optical fiber which carries both directions of traffic as well as supervisory signals at one of two wavelengths. The optical telephones include means for separating these two wavelengths as well as opto-acoustic and acousto-optic converters.

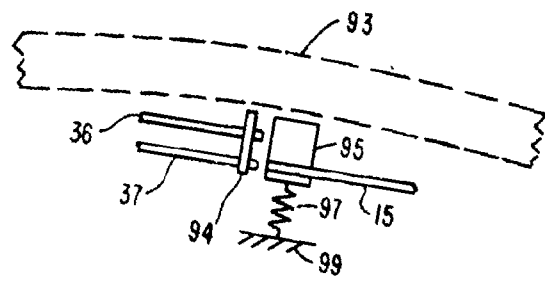

FIG. 3

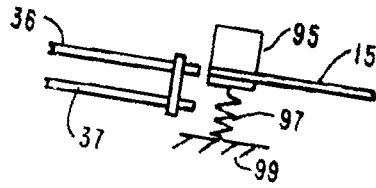

FIG. 4

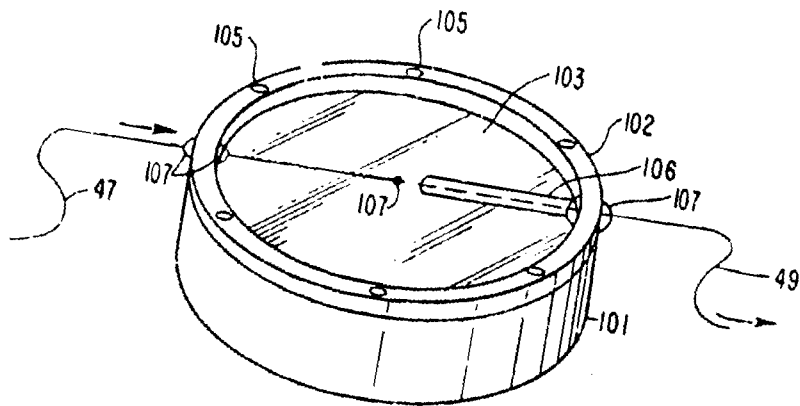

FIG. 5

FIG. 6

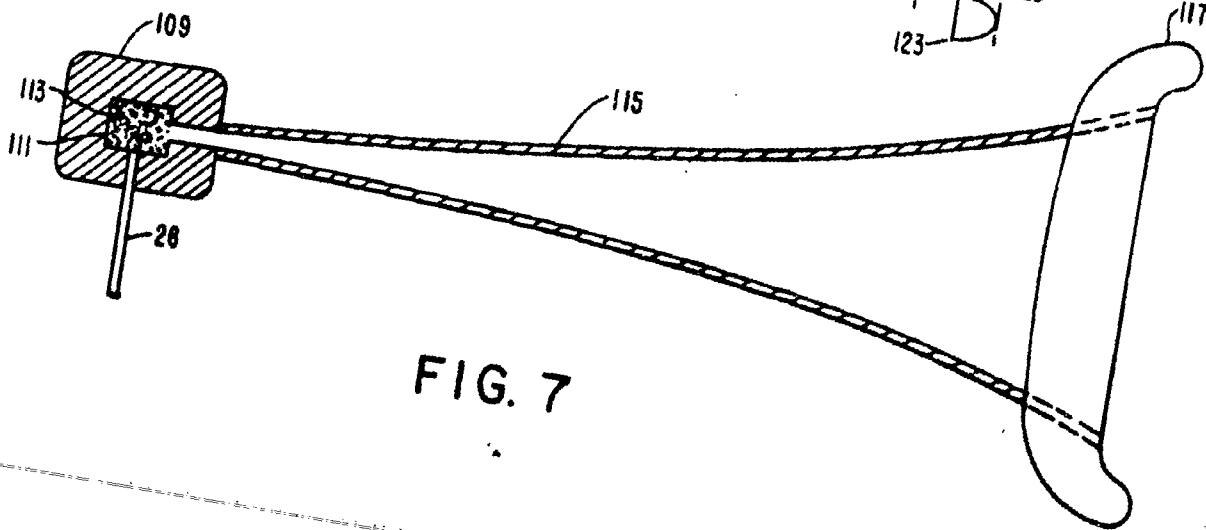
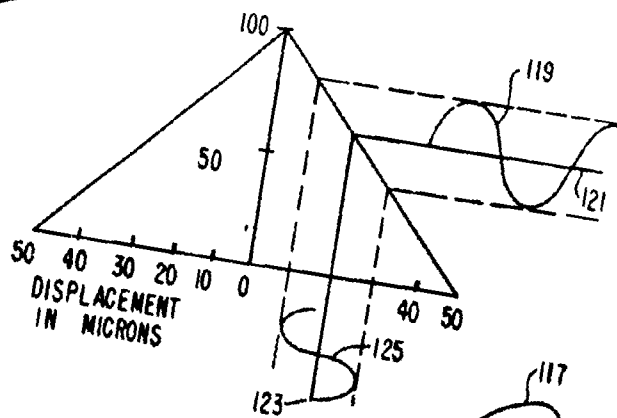

FIG. 7

**IN THE UNITED STATES PATENT AND TRADEMARK
OFFICE COMBINED DECLARATION AND
POWER OF ATTORNEY**

ATTORNEY'S DOCKET NO. CECOM D-3248

As a below named inventor, I hereby declare that:
 My residence, post office address and citizenship are as stated below next to my name,
 I believe I am the original, first and sole inventor (if only one name is listed below) or an original, first and joint
 inventor (if plural names are listed below) of the subject matter which is claimed and for which a patent is sought on
 the invention entitled A SINGLE OPTICAL FIBER TELEPHONE SYSTEM

the specification of which

(Check one) is attached hereto
 was filed on _____ as
 Application Serial No. _____
 and was amended on _____
(if applicable)

I hereby state that I have reviewed and understand the contents of the above identified specification, including the
 claims, as amended by an amendment referred to above.

I acknowledge the duty to disclose information which is material to the examination of this application in accord-
 ance with Title 37, Code of Federal Regulations, §1.56(a).

I hereby claim foreign priority benefits under Title 35, United States Code, §119 of any foreign application(s) for
 patent or inventor's certificate listed below and have also identified below any foreign application for patent or in-
 ventor's certificate having a filing date before that of the application on which priority is claimed

PRIOR FOREIGN APPLICATION(S)

APPLICATION NUMBER	COUNTRY	DATE OF FILING (day, month, year)	PRIORITY CLAIMED	
_____	_____	_____	<input type="checkbox"/> YES	<input type="checkbox"/> NO
_____	_____	_____	<input type="checkbox"/> YES	<input type="checkbox"/> NO
_____	_____	_____	<input type="checkbox"/> YES	<input type="checkbox"/> NO

I hereby claim the benefit under Title 35, United States Code, §120 of any United States application(s) listed below
 and, insofar as the subject matter of each of the claims of this application is not disclosed in the prior United States
 application in the manner provided by the first paragraph of Title 35, United States Code, §112. I acknowledge the
 duty to disclose material information as defined in Title 37, Code of Federal Regulations, §1.56(a) which occurred
 between the filing date of the prior application and the national or PCT international filing date of this application:

_____	_____	_____
<i>(Application Serial No.)</i>	<i>(Filing Date)</i>	<i>(Status)</i>
		<i>(patented, pending, abandoned)</i>
_____	_____	_____
<i>(Application Serial No.)</i>	<i>(Filing Date)</i>	<i>(Status)</i>
		<i>(patented, pending, abandoned)</i>

And I hereby give irrevocable control of this application for Letters Patent to the Government of the United States,
 as represented by the Secretary of the Army, and appoint

ANTHONY T. LANE, #19,964; ROBERT P. GIBSON, #19,577;
 JEREMIAH G. MURRAY #20,533; MAURICE W. RYAN #20,159
 or any of them, our attorneys or agents, with full power of substitution and revocation, to prosecute this applica-
 tion, to make alterations and amendments therein, to sign the drawings, to receive the patent, and to transact all
 business in the Patent and Trademark Office connected therewith.

Direct telephone calls to MAURICE W. RYAN (201) 532-3187

Direct correspondence to ANTHONY T. LANE, Assistant Command Counsel,
 Patent Law Division, 5001 Eisenhower Ave., Alexandria, VA 22333
 Wherefore I pray that Letters Patent be granted to me for the invention or discovery described and claimed in the
 foregoing specification and claims, and I hereby subscribe my name to the attached specification and claims, declara-
 tion, power of attorney, and this petition.

DECLARATION CONTINUATION FORM
(Use this form as a continuation page)

ATTORNEY'S DOCKET NO.

CECOM D-3248

201	FULL NAME OF INVENTOR	LAST NAME FELDMAN	FIRST NAME NATHAN	MIDDLE NAME W.
	RESIDENCE & CITIZENSHIP	CITY OR OTHER LOCATION LONG BRANCH	STATE OR FOREIGN COUNTRY NEW JERSEY	COUNTRY OF CITIZENSHIP USA
	POST OFFICE ADDRESS	POST OFFICE ADDRESS 910 VAN COURT AVE	CITY LONG BRANCH	STATE & ZIP CODE/COUNTRY N.J. 07740 USA
202	FULL NAME OF INVENTOR	LAST NAME	FIRST NAME	MIDDLE NAME
	RESIDENCE & CITIZENSHIP	CITY OR OTHER LOCATION	STATE OR FOREIGN COUNTRY	COUNTRY OF CITIZENSHIP
	POST OFFICE ADDRESS	POST OFFICE ADDRESS	CITY	STATE & ZIP CODE/COUNTRY
203	FULL NAME OF INVENTOR	LAST NAME	FIRST NAME	MIDDLE NAME
	RESIDENCE & CITIZENSHIP	CITY OR OTHER LOCATION	STATE OR FOREIGN COUNTRY	COUNTRY OF CITIZENSHIP
	POST OFFICE ADDRESS	POST OFFICE ADDRESS	CITY	STATE & ZIP CODE/COUNTRY

I further declare that all statements made herein of my own knowledge are true and that all statements made on information and belief are believed to be true; and further that these statements were made with the knowledge that willful false statements and the like so made are punishable by fine or imprisonment, or both, under section 1001 of Title 18 of the United States Code, and that such willful false statements may jeopardize the validity of the application or any patent issue thereon.

SIGNATURE OF INVENTOR 201 <i>N. Feldman</i>	SIGNATURE OF INVENTOR 202	SIGNATURE OF INVENTOR 203
DATE <i>8/30/84</i>	DATE	DATE