

Serial No. 605243
Filing Date 12 February 1996
Inventor Promode R.Bandyopadhyay

NOTICE

The above identified patent application is available for licensing. Requests for information should be addressed to:

OFFICE OF NAVAL RESEARCH
DEPARTMENT OF THE NAVY
CODE OCCC3
ARLINGTON VA 22217-5660

19960614 039

DTIC QUALITY INSPECTED 1

DISTRIBUTION STATEMENT A

Approved for public release;
Distribution Unlimited

1 Navy Case No. 76309

2
3 A BRISK MANEUVERING DEVICE FOR UNDERSEA VEHICLES

4
5 STATEMENT OF GOVERNMENT INTEREST

6 The invention described herein may be manufactured by or for
7 the Government of the United States of America for Governmental
8 purposes without the payment of any royalties thereon or
9 therefor.

10
11 BACKGROUND OF THE INVENTION

12 (1) Field of the Invention

13 The invention relates generally to the field of nautical
14 vehicles and more particularly to arrangements for use in
15 connection with nautical vehicle which providing for brisk
16 maneuvering of such vehicles.

17 (2) Description of the Prior Art

18 In a number of areas, it is desirable to provide a brisk
19 ("rapid") maneuvering capability for nautical vehicles, such as
20 small, manned or unmanned undersea vehicles, torpedoes and the
21 like, moving below the surface in a fluid environment. Brisk
22 maneuvering may be used, for example, as a defense mechanism, to
23 enable a vehicle to avoid destruction in a combat situation, or
24 to steer a vehicle away from an unexpected obstruction. Brisk
25 maneuvering can enable the vehicle to rapidly turn with a
26 relatively small turning radius, and with relatively low noise.

1 A brisk maneuvering device can also be used for so called
2 "station keeping" of small unmanned underwater vehicles buffeted
3 with streams in various directions.
4

5 SUMMARY OF THE INVENTION

6 It is therefore an object of the invention to provide a new
7 and improved brisk maneuvering arrangement for use in connection
8 with a nautical vehicle.

9 In brief summary, the invention provides a nautical vehicle
10 for traveling in a fluid environment, the nautical vehicle
11 comprising a body having a dorsal fin mounted thereon. The body
12 comprises a sidewall, a forward nose and a rear propulsor for
13 propelling the vehicle in an axial direction. The dorsal fin is
14 mounted on the sidewall, and includes a dorsal fin surface and
15 camber generating element for generating a camber to provide a
16 sideways thrust on said body to facilitate brisk maneuvering of
17 the vehicle in the fluid environment.
18

19 BRIEF DESCRIPTION OF THE DRAWINGS

20 This invention is pointed out with particularity in the
21 appended claims. The above and further advantages of this
22 invention may be better understood by referring to the following
23 description taken in conjunction with the accompanying drawings,
24 in which:

25 FIG. 1 is an end view of a nautical vehicle including a
26 brisk maneuvering arrangement in accordance with the invention;

1 FIG. 2 is a side view of the vehicle depicted in FIG. 1;
2 FIG. 3 is a top view of the vehicle depicted in FIG. 1;
3 FIG. 4 is another end view of the nautical vehicle depicted
4 in FIG. 1, useful in understanding the invention;

5 FIG. 5A depicts a plan view of a nautical vehicle including
6 a second embodiment of a brisk maneuvering arrangement in
7 accordance with the invention; and

8 FIGS. 5B and 5C are sectional views helpful in understanding
9 the operation of the embodiment depicted in FIG. 5A.

10
11 DESCRIPTION OF THE PREFERRED EMBODIMENT

12 FIGS. 1 through 3 are respectively end, side and top views
13 of a nautical vehicle 10 including a brisk maneuvering
14 arrangement in accordance with the invention. With reference to
15 FIGS. 1 through 3, nautical vehicle 10 includes a generally
16 cylindrical sidewall 11 having a blunt forward nose 12 and a rear
17 propulsor 13 such as a propeller and an upper dorsal fin 14 which
18 provides for brisk maneuvering in accordance with the invention.
19 In addition, the vehicle 10 may include an anal fin 15. The
20 propulsor 13 will normally propel the vehicle 10 through a fluid
21 environment in an axial direction that is represented by an arrow
22 20 as shown in FIG. 2, which it turn results in a relative flow
23 of the fluid over the vehicle in a direction represented by arrow
24 21.

25 The vehicle's dorsal fin 14 may be used to facilitate the
26 brisk, relatively low-noise maneuvering of the vehicle 10 in an

1 emergency situation, in particular in assisting the vehicle to
2 turn or otherwise diverting its direction of travel from the
3 forward direction. The dorsal fin 13 may normally be positioned
4 in a retracted position which is flush with the cylindrical
5 surface of the sidewall 11, and may be lifted into a deployed
6 position as represented by the arrow 16 depicted in FIG. 1. In
7 addition, the anal fin 15, if present, may be positioned flush
8 with the cylindrical surface of sidewall 11, along the lower
9 portion of the vehicle 10, and lifted into a deployed position as
10 represented by the arrow 17.

11 To facilitate the brisk, relatively low-noise maneuvering of
12 the vehicle 10 in an emergency situation, the dorsal fin 14 is
13 given a camber that interacts with the fluid environment to
14 generate a side thrust which assists the vehicle 10 to turn or
15 otherwise diverting its direction of travel from the forward
16 direction. To accomplish the camber, the dorsal fin 14 is
17 supported by hinges at several positions along its length (that
18 is, in three positions along the length of the vehicle 10), in
19 particular at its forward point 30, at its rear point 32, and at
20 an arm 31 positioned intermediate therebetween. The arm 31
21 extends generally outwardly from the vehicle's sidewall 11, and
22 is attached to the dorsal fin 14 along its length. The arm 31
23 may pivot in a plane generally transverse to the axis of vehicle
24 10 (as shown in FIGS. 3 and 4), and therefore transverse to the
25 direction of travel when the vehicle 10 is traveling in a forward
26 direction. The rear point 32 is mounted in a slot 33 (shown in

1 FIG. 3), which is generally parallel to the axis of the vehicle
2 10, and therefore parallel to the direction of travel when the
3 vehicle 10 is traveling in a forward direction. Preferably, the
4 dorsal fin 14 will be constructed of a relatively stiff but
5 flexible material, or a material such as fiberglass, rubber or
6 cloth or synthetic material with similar flexibility
7 characteristics, so that the fin 14 may be retracted, deployed,
8 and provided with the camber necessary to provide the sideways
9 thrusts as described herein. It should be noted that if the
10 material of dorsal fin 14 is reasonably stiff like fiber glass,
11 cambering by sliding arm 31 will result in a circular arc (FIG.
12 3) rather than a triangle as shown in FIG. 3.

13 The dorsal fin 14 is provided with a camber, to provide the
14 vehicle with a sideways thrust to assist in maneuvering, by
15 suitable manipulation of the arm 31 (as shown in FIGS. 3 and 4)
16 and rear hinge 32 in slot 33. In particular, by moving the arm
17 31 in one direction relative to the direction of travel, and
18 moving the rear hinge 32 forwardly in slot 33, a sideways thrust
19 is provided in the opposite direction. Accordingly, when the
20 direction of travel of vehicle 10 is to be diverted toward, for
21 example, the right, the arm 31 will be moved to the right thereby
22 to provide a sideways thrust in a rightward direction. On the
23 other hand, when the direction of travel is to be diverted to the
24 left, the arm 31 will be moved to the left thereby to provide a
25 sideways thrust in a leftward direction.

1 It will be appreciated that the amount of sideways thrust
2 which the dorsal fin 14 will preferably provide will generally be
3 related to the radius of the vehicle's turn, so that, for larger
4 turning radii small amounts of sideways thrust will suffice but
5 for smaller radii it is preferable to provide larger amounts of
6 sideways thrust. In addition, the amount of sideways thrust
7 provided by the dorsal fin 14 is directly related to the amount
8 which the arm 31 pivots from the normal (that is, from a
9 direction orthogonal to the surface of sidewall 11, as shown in
10 FIGS. 3 and 4), so that for a pivot of a relatively small angle a
11 relatively small amount of sideways thrust will be generated by
12 the dorsal fin 14, but for a pivot of a larger angle a larger
13 amount of sideways thrust will be provided. Accordingly, it will
14 be appreciated that, when it is desired to turn the vehicle 10
15 with a relatively large radius, it may suffice to pivot arm 31
16 only a small degree from the normal, but for turns of smaller
17 radius it may be preferable to pivot arm 31 a larger extent to
18 provide a greater sideways thrust. The thrust due to the
19 cambered fin is generally proportional to the area of the fin and
20 the speed of the vehicle (more particularly, roughly the square
21 of the vehicle's speed).

22 The camber provided for dorsal fin 14 will also provide
23 another benefit, namely, shedding of large scale vortices which
24 may otherwise form proximate the vehicle 10 when its direction of
25 travel deviates from the forward direction, which may increase
26 drag on movement of vehicle 10, and may also generate noise

1 proximate the vehicle 10. By providing a cambered surface for
2 dorsal fin 14, the vortices are displaced further from the
3 sidewall of the vehicle 10 and are reduced in size, both of which
4 will reduce potential drag forces created thereby on the vehicle.
5 In addition, reduction in vortex size will result in a reduction
6 in noise. Because the trailing edge of the cambered fin 14 is at
7 an angle to the axis of the vehicle's cylindrical sidewall 11,
8 the wake of the vortex generated by the fin will spiral around
9 the tail cone of the vehicle 10. This will help stabilize the
10 brisk maneuvering motion which is another advantage of the
11 cambered dorsal fin 14.

12 While the invention has been described in connection with a
13 dorsal fin 14 mounted exteriorly of the sidewall 11 of vehicle
14 10, it will be appreciated that other means may instead be
15 provided to generate a sideways thrust for assisting in brisk
16 maneuvering in a generally similar manner. For example, sideways
17 thrusts may be generated by injection of fluid outwardly along a
18 direction similar to the contour of the fin 14. In such an
19 operation, a number of perforations may be provided at various
20 radial positions along the sidewall 11, through which fluid may
21 be selectively injected. Alternatively, magnetohydrodynamic
22 forces may be generated in connection with the surrounding fluid
23 environment to generate the sideways thrusts.

24 In another alternative, which will be described in
25 connection with FIGS. 5A through 5C, instead of using a fin 14
26 described above in connection with FIGS. 1 through 4, a finlet 40

1 is provided which has a much smaller height than that of fin 14.
2 FIG. 5A depicts a plan view of the vehicle 10', and FIGS. 5B and
3 5C depict a portion of a cross section of vehicle 10' taken along
4 a plane generally perpendicular to the axis of the cylindrical
5 sidewall, showing a detail of the sidewall 11' proximate the
6 finlet 40. The finlet may be mounted on an interior wall 41
7 which generally conforms to the interior surface of sidewall 11'.
8 When a brisk maneuvering operation is not required, the interior
9 wall 41 may maintain finlet 40 in a retracted position in a slot
10 44 (FIGS. 5B and 5C). When a brisk maneuvering operation is
11 required, the interior wall 41 may deploy the finlet 40 by moving
12 it out radially through the slot 44 (reference FIG. 5C). At that
13 time a vortex, identified by reference numeral 43, will be formed
14 by separating and rolling up the spanwise vorticity in the
15 boundary layer proximate the sidewall 11 into a well-defined
16 vortex 43. With the finlet 40 (FIGS. 1 through 4), the flow over
17 the finlet 40 is generally laminar, and the fin's camber provides
18 the required sideways thrust, and with the finlet 40 (FIGS. 5A
19 through 5C) the vortex 43 provides the required sideways thrust.
20 One advantage of the finlet 40 over the fin 14 is that the finlet
21 40 occupies much less radial space than that for fin 14. Also,
22 the amount of sideways thrust provided by the finlet 40 may be
23 adjusted by adjusting the distance by which the finlet 40 extends
24 into the boundary layer, whereas sideways thrust provided by fin
25 14 is determined by the amount of camber of the fin 14.

1
2
3
4
5
6
7

The preceding description has been limited to specific
embodiments of this invention. It will be apparent, however,
that variations and modifications may be made to the invention,
with the attainment of some or all of the advantages of the
invention. Therefore, it is the object _____ to
cover all such variations and modifications as come within the
true spirit and scope of the invention.

1 Navy Case No. 76309

2
3 A BRISK MANEUVERING DEVICE FOR UNDERSEA VEHICLES

4
5 ABSTRACT OF THE DISCLOSURE

6 A nautical vehicle for traveling in a fluid environment, the
7 nautical vehicle comprising a body having a dorsal fin mounted
8 thereon. The body comprises a sidewall, a forward nose and a
9 rear propulsor for propelling the vehicle in an axial direction.
10 The dorsal fin is mounted on the sidewall, and includes a dorsal
11 fin surface and camber generating element for generating a camber
12 to provide a sideways thrust on said body to facilitate brisk
13 maneuvering of the vehicle in the fluid environment.

FIG. 2

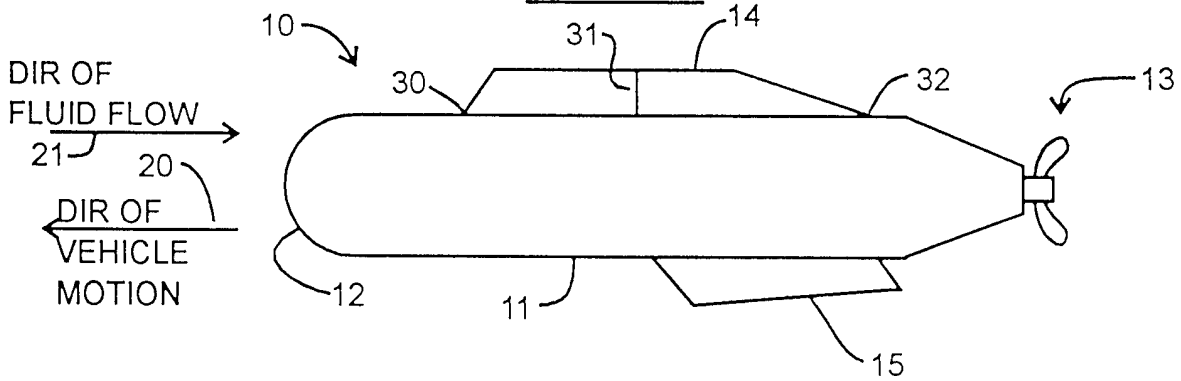

FIG. 3

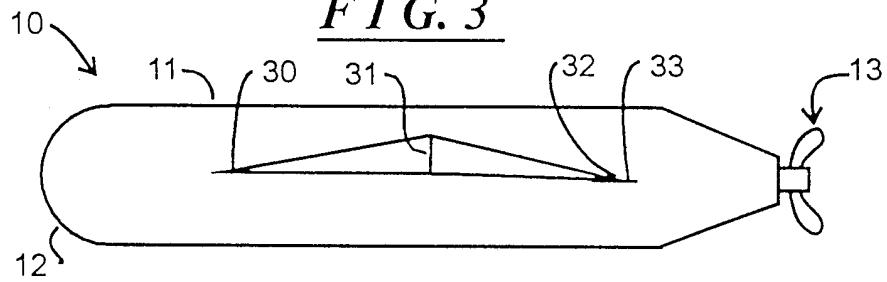

FIG. 1

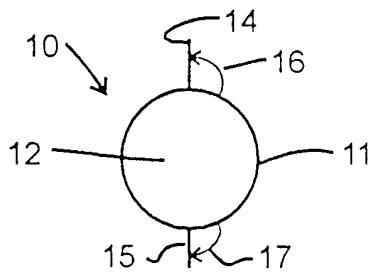

FIG. 4

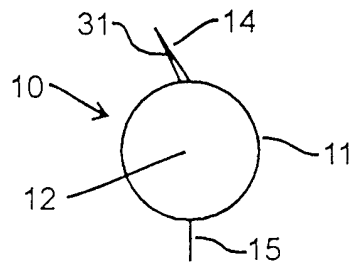

FIG. 5B

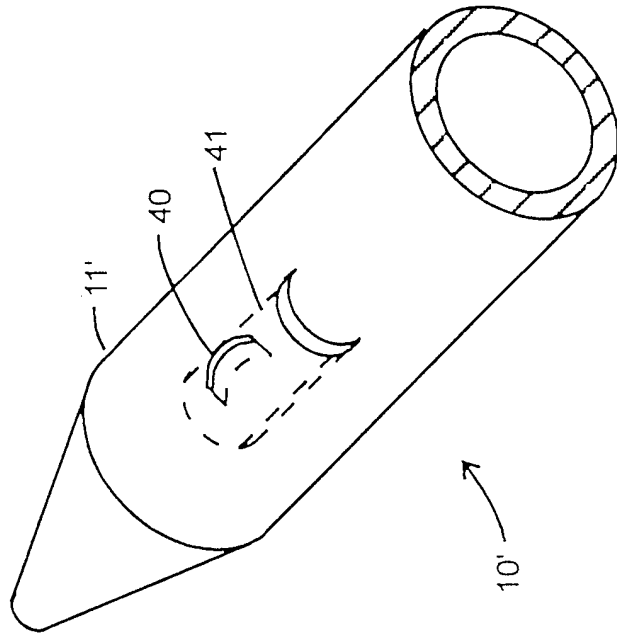
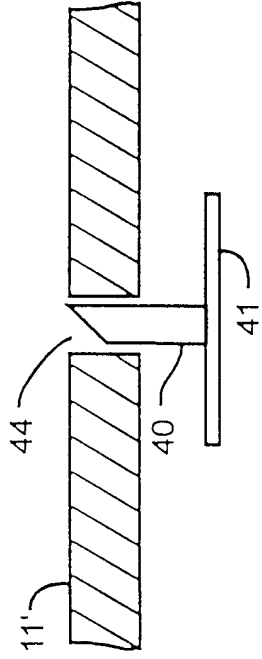

FIG. 5A

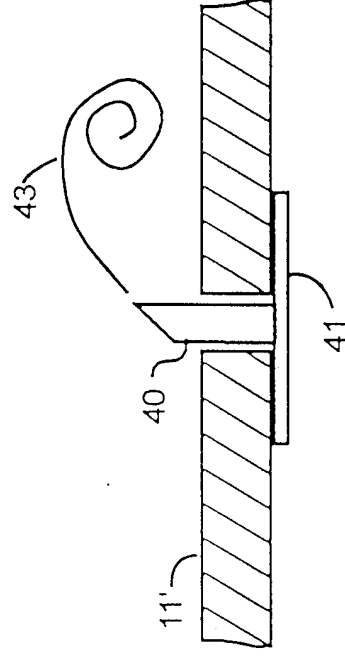

FIG. 5C