

Serial Number                    09/372,108  
Filing Date                      11 August 1999  
Inventor                         Vincent J. Vendetti  
                                       Michael M. Canaday

NOTICE

The above identified patent application is available for licensing. Requests for information should be addressed to:

OFFICE OF NAVAL RESEARCH  
DEPARTMENT OF THE NAVY  
CODE 00CC  
ARLINGTON VA 22217-5660

**DISTRIBUTION STATEMENT A**  
**Approved for Public Release**  
**Distribution Unlimited**

19990915 048

DTIC QUALITY INSPECTED 4

**SHOCK ABSORBING MOUNT FOR ADJUSTABLE BARREL**

**ORIGIN OF THE INVENTION**

5       The invention described herein was made in the performance of official duties by an employee of the Department of the Navy and may be manufactured, used, licensed by or for the Government for any governmental purpose without the payment of any royalty thereon.

10

**BACKGROUND OF THE INVENTION**

**1.0 Field of the Invention**

15       The present invention relates to firearm technology and, more particularly, to a releasable mount, which when loosened allows for spherical adjustment of the barrel of a spotting rifle and, which when tightened, firmly maintains the desired barrel orientation.

**2.0 Description Of the Prior Art**

20       Spotting rifles have means for adjusting the orientation of the barrel of the rifle so as to accurately position the barrel to bring to bear the fire power thereof onto a target. For such adjustment, the barrel needs to be allowed to pivot relative to the rifle, more particularly, relative to the receiver portion of the spotting rifle.

5 Spotting rifles are also used in conjunction with other  
firearms, such as a rocket launcher. In such applications, the  
rifle receiver is rigidly connected to the launch tube of the  
rocket launcher. Using the weapon is as follows: tracer rounds are  
fired from the spotting rifle until the gunner, controlling the  
10 rocket launcher, feels that he is accurately hitting the target.  
At this point, the gunner switches the weapon to launch mode and  
fires the rocket. The rocket and the spotting rounds have the same  
trajectory allowing the rocket launcher to hit the same target as  
the tracers.

15

Prior art spotting rifles used in conjunction with rocket  
launchers have allowed the barrel to pivot relative to the receiver  
portion of the spotting rifle, but did so without firmly securing  
the barrel to the receiver portion of the spotting rifle. Because  
20 the barrel was not firmly mounted, the barrel would "jump" when the  
spotting rifle was fired causing a large group, that is, scattering  
of bullets, onto the target. The prior art spotting rifles secured  
the barrel to the receiver portion by using set screws to improve  
the accuracy of the rifle and, thus, the rocket launcher, but it  
25 was determined that the set screws would back out of their  
capturing holes from the vibration caused by the firing of the  
spotting rifle and the rocket launcher. In addition, analysis was  
performed that showed high levels of stress were being encountered  
at the barrel/set screw interface which caused the loosening of the  
30 set screws from their capturing holes. It is desired that a

5 releasable mount be provided which when loosened allows for the adjustment of the orientation of the barrel and, which when tightened, firmly maintains the orientation of the barrel during firing of the spotting rifle and the rocket launcher.

10

#### SUMMARY OF THE INVENTION

Accordingly, it is a primary object of the present invention to provide for mounting means such, when loosened, allows for the adjustment of a barrel of spotting rifle, and when tightened, 15 maintains the desired orientation of the barrel, while at the same time absorbs high stress that normally occurs during the firing of the spotting rifle and also during the firing of the associated rocket launcher.

20 It is another object of the present invention to provide for mounting means that allows for spherical adjustment for the barrel of the spotting rifle so that the spotting rifle may be more effectively used with a rocket launcher.

25 It is yet another object of the present invention to provide for an adjustable means for the mounting of a barrel that has shock absorbing capabilities so as to maintain the desired orientation of the barrel of the spotting rifle.

5        It is a further object of the present invention to provide for adjustable mounting means that can be tightened and pinned to the receiver portion of the spotting rifle.

10        In accordance with these and other objects, the invention provides a firearm comprising a barrel, a receiver portion, a mount, and shock absorbing means. The barrel has first and second ends and serves as a discharge tube for the firearm. The receiver portion of the firearm has means for receiving and holding the second end of the barrel. The mount has means for releasably  
15        connecting to the receiver portion. The shock absorbing means is lodged in the mount and interposed between the barrel and the mount.

#### BRIEF DESCRIPTION OF THE DRAWINGS

20

The foregoing objects and advantages of the present invention will be more fully understood from the following detailed description having reference to the appended drawings wherein:

25        Fig. 1 is an overall view of the launcher/spotter rifle assembly of the present invention.

Fig. 2 is a sectional drawing illustrating the adjustable mount of the present invention; and

5            Fig. 3 is a section of the drawing taken along line 3-3 of Fig  
2, illustrating some of the details for connecting the adjustable  
mount to the launcher/spotter rifle assembly of Fig. 1.

#### DETAILED DESCRIPTION OF THE PREFERRED EMBODIMENTS

10

Referring to the drawings, wherein in the same reference  
number indicates the same element throughout, there is shown in  
Fig. 1 an overall view of a typical launcher/spotter rifle assembly  
designated generally by the reference number 10. The rocket  
15 launcher/spotter rifle assembly 10 has a handle 12 that is used in  
the operation of a trigger 14. The launcher/spotter rifle assembly  
10 further comprises a barrel 16 that is connected on the muzzle  
end thereof to a front bracket 18 of the launcher/spotter rifle  
assembly 10 by means of bore sighting adjustment device 20, to be  
20 further described with reference to Fig. 3, and on the other end  
thereof to a receiver assembly 22 of the launcher/spotter rifle  
assembly 10. The barrel 16 is connected to the receiver assembly  
22 by means of a mount assembly 100 which is of particular  
importance to the present invention and may be further described  
25 with reference to Fig. 2.

Fig. 2 illustrates the barrel 16, which serves as the  
discharge tube for a spotting rifle of Fig. 1 and has a first or  
muzzle end (previously mentioned with regard to Fig. 1) 16A and a  
30 second end (previously mentioned with regard to Fig. 1) 16B, as

5 well as having a centerline 24 along which is located a center 26  
about which the barrel 16 is rotated in a spherical manner to be  
described. The spotting rifle is interchangeably referred to  
herein as simply a rifle or, more generally, as a firearm.  
Similarly, the launcher/spotter assembly 10 is sometimes referred  
10 to herein as a firearm. Although the practice of the invention is  
particularly suited for a spotting rifle operated in conjunction  
with a launcher both forming the launcher/spotter rifle assembly  
10, the practice of the invention is also applicable to other type  
firearms. The launcher/spotter assembly 10 further comprises the  
15 receiver portion 22, having first and second ends 22A and 22B,  
respectively.

The mount assembly 100 of Fig. 2 has a threaded insert 102  
which interconnects the receiver portion 22 to a barrel clamp 104  
20 of the mount assembly 100. If desired, the threaded insert 102 can  
be eliminated if the receiver portion 22 is provided with external  
threads so that the barrel clamp 104 may threadly engage with the  
receiver portion 22. The barrel clamp 104 has first and second  
ends 106 and 108, with the first end 106 being threadedly engaged  
25 with the threaded insert 102.

The mount assembly 100 further comprises a barrel bushing 110  
which provides a shock absorbing means that is interposed between  
the barrel 16 and the barrel clamp 104. In one preferred  
30 embodiment, the shock absorbing means 110 is a urethane compression

5 spring preferably having a spring constant of about 12,000 lbs. per  
inch. If desired, materials other than urethane may be used for  
the preferred embodiment so long as the spring constant of 12,000  
lbs. per inch or less is maintained. For other embodiments for  
totally different weapon systems, the barrel bushing 110 may  
10 require a higher or lower spring constant than the 12,000 lbs., per  
inch. For all embodiments, the stiffness of the barrel bushing 100  
should be less than that of the surrounding steel.

The mount assembly 100 further preferably comprises a slide  
15 washer 112 and a barrel collar 114. The slide washer 112 and the  
barrel collar 114 have faces 112A and 114A, respectively, that are  
curved in a complementary manner to each other. The faces 112A and  
114A are spherically curved by means of their respective spherical  
radius relative to the center 26 of rotation of the barrel 16.

20

The first end 16A of the barrel 16 mates with the barrel  
sighting adjustment device 20 which is positioned inside of the  
front bracket 18. The front bracket 18 and barrel sighting  
adjustment device 20 orient the barrel 16 which is rigidly fixed by  
25 the barrel clamp 104. The sighting adjustment device 20 has set  
screws 20A which may be further described with reference to Fig. 3  
which is a sectional view taken along line 3-3 of Fig. 2.

Fig. 3 illustrates three set screws 20A each connected to the  
first bracket 18 by means of respective self-locking helicoils 20B.

5 Each of the set screws 20A is adjustable to orient the muzzle end  
16A to its desired line of sight.

#### OPERATION OF MOUNT ASSEMBLY 100

10 In operation, and with reference to Figs. 2 and 3, the mount  
assembly 100 is connected to the associated launcher/rifle assembly  
10 via the threaded insert 102. More particularly, the threaded  
insert 102 threads to the receiver portion 22 on one end and to the  
barrel clamp 104 on the other end. The barrel clamp 104 houses the  
clamp bushing 110, the slide washer 112 and the barrel collar 114.  
15 The second end 16B of the barrel 16 has a spherical face 16C which  
rests against a spherical face 22C on the receiver portion 22 as  
shown in Fig. 2. The barrel 16 is rigidly fixed by tightening the  
barrel clamp 104.

20 The barrel 16 is adjusted by loosening the barrel clamp 104  
which allows the barrel 16 to pivot spherically about the center of  
rotation 26. Three set screws 20A (shown most clearly in Fig. 3)  
which are mounted to the front bracket 18 at the muzzle end 16A of  
the barrel 16 are adjusted to locate the barrel 16 based on bore  
25 sighting. The barrel clamp 104 is then tightened fixing the barrel  
16 to the receiver portion 22.

In actual operation, when the barrel 16 is firmly attached to  
the receiver portion 22, the clamp bushing 110, preferably in the  
30 form of an urethane spring, acts as the shock absorbing means to

5 absorb the high stress from the firing shock typically created by  
the discharge of the launcher/spotter rifle assembly 10.

10 It should now be appreciated that the practice of the present  
invention provides for the releasably attachable mount, which when  
loosened, allows for the spherical adjustment of the barrel of a  
spotting rifle and, which when attached, firmly mounts the  
adjustment means to the receiver portion of the launcher/spotter  
rifle assembly 10, while at the same time has shock absorbing means  
which absorbs the high stress commonly created by the firing shock  
15 experience when discharging the launcher/spotter rifle assembly 10.

Although the invention has been described relative to a  
specific embodiment thereof, there are numerous variations and  
modifications that will be readily apparent to those skilled in the  
20 art in light of the above teaching. It is, therefore, understood  
that the invention may be  
practiced other than as specifically described.

ABSTRACT OF THE DISCLOSURE

5 Disclosed is a mount releasably attached to a launcher/spotting rifle assembly. The mount, when released, allows for the barrel of the spotting rifle of the launcher/spotting rifle assembly to be adjusted in a spherical manner, and when tightened, rigidly affixes the barrel to the launcher/spotting rifle assembly,  
10 while at the same time provides shock absorbing means which absorbs high stress from the firing shock typically created by the discharge of the launcher/spotting rifle assembly. The shock absorbing means acts to preserve the rigid and accurate attachment of the barrel to the launcher/spotting rifle assembly.

DOCKET : NAVY CASE 79668  
INVENTOR : VINCENT J VENDETTI

10  
11  
12

100 (SEE FIG. 2)

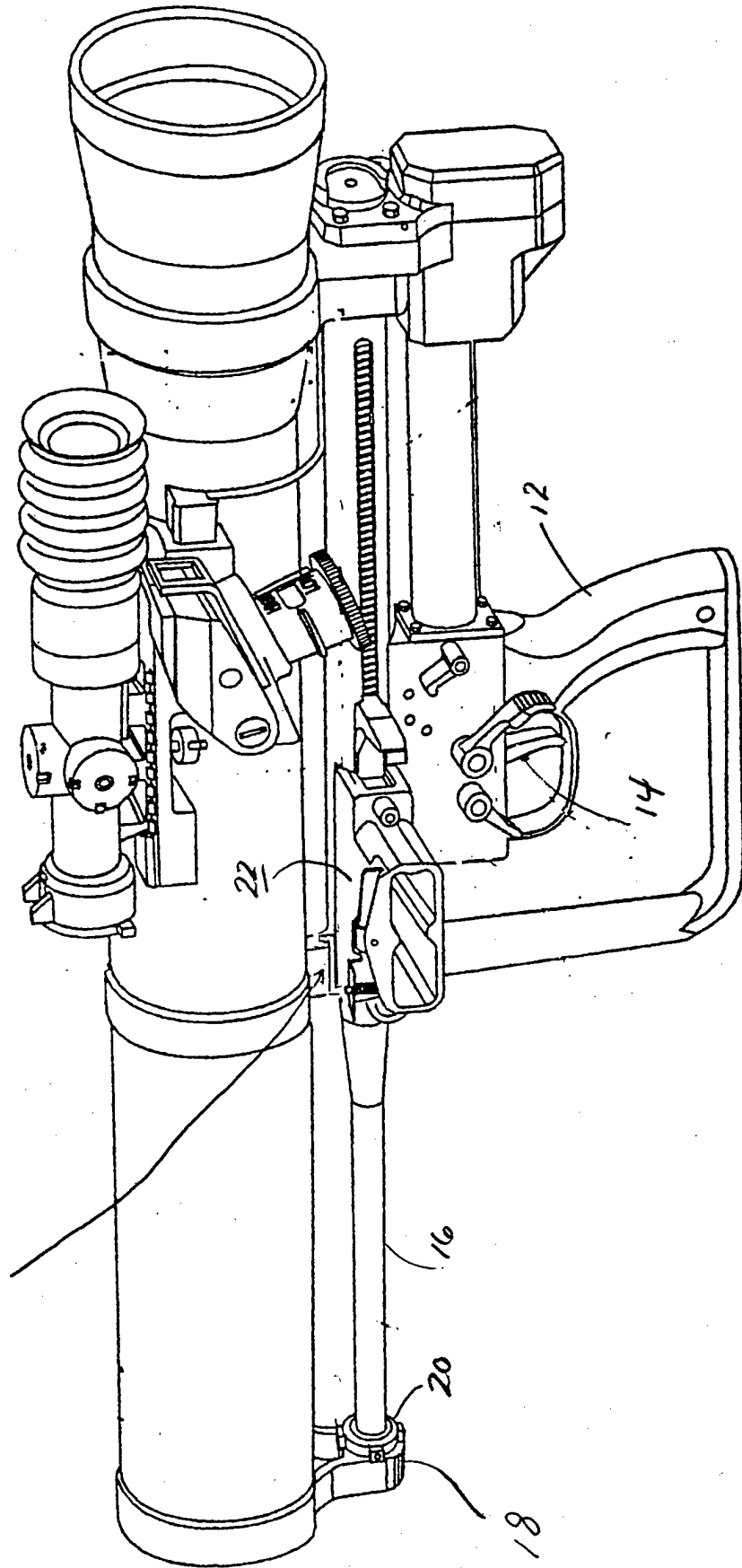

FIG 1

DOCKET: NAVY CASE 79668

INVENTOR: VINCENT J VENDETTI

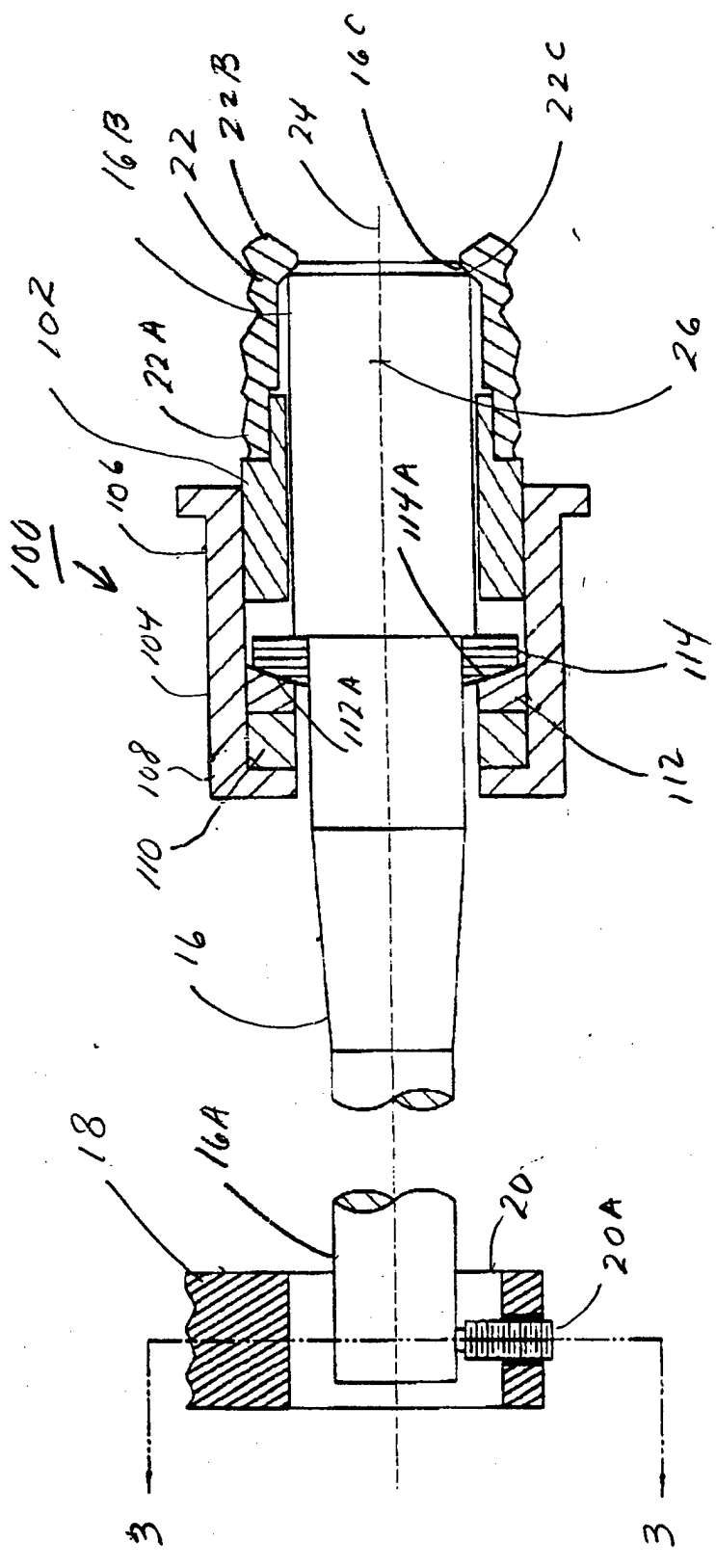

FIG 2

DOCKET: NAVY CASE 79668

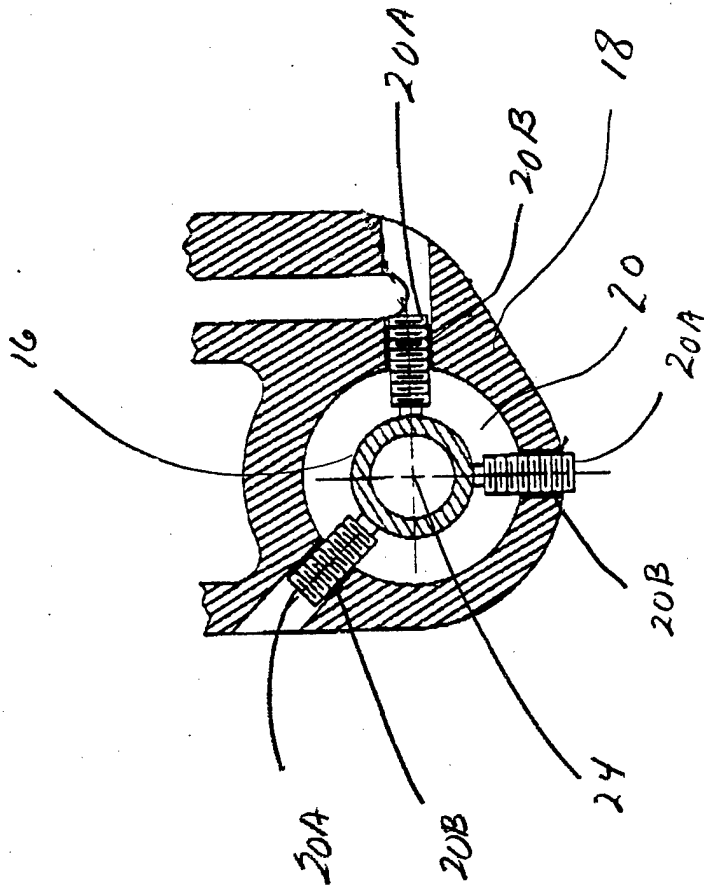

FIG 3