

AD P 002168

TOPOLOGICAL GROUNDING ANOMALIES



W. Graf and J. E. Nanevich  
SRI International, Menlo Park, California

ABSTRACT

Two principal anomalies found in current grounding practices are discussed: The ground conductor penetrating a shield, and a grounded but open shield. Good grounding practices are simple when viewed from the topological viewpoint. A system is divided into different zones, each separated from the other by an electromagnetically impervious barrier, and each zone has its own ground system. Because lightning is a broadband phenomenon, the separation of the zones must also be achieved over a broadband if a system is to be protected against the effects of lightning. It is well understood that aircraft avionics systems do not require a connection to earth to be protected against lightning. This is much less recognized for ground equipment and ground facilities. Here, the practice of connecting the signal reference ground to the earth electrode has serious consequences (in the event of a lightning strike) for the equipment connected to it, unless the ground rod has zero impedance. In the topological approach, such a connection is only permitted if the grounding conductor does not penetrate the barrier surfaces that separate the different zones of the system. Experimental data to support this approach are discussed.

WHEN A COMPLEX SYSTEM such as a new computer is delivered to a customer, the field engineer frequently spends one or more days working with the system--moving grounds from place to place--until he comes up with the magic arrangement that renders the system self-compatible. After the first local thunderstorm often he must return to continue working his magic until the system also becomes hardened to externally-generated transients. Questions naturally arise as to why ground connections should be so critical to the proper functioning of the system and why it is so difficult to design and install the ground system properly the first time.

In considering this problem, it appears that much of the difficulty is caused by deviating from modern topological interference control principles<sup>(1,2)\*</sup> in the design of the grounding system. A consequence of the deviation is that the grounding system is thereby forced to perform inappropriate functions and to meet standards almost impossible to achieve. Furthermore, it appears that these deviations frequently are a consequence of the perception that somehow grounding, bonding, and shielding are intertwined and that together that constitute the array of techniques available to the EMC engineer. Actually, the proper roles of grounding and bonding have so little to do with interference control design that they should not be considered interference control tools. Of course, poor bonding or the improper application of grounding can compromise an otherwise good design. In this paper, we will discuss topological interference control techniques, the role of grounding in their application, and how improperly applied grounding can degrade system immunity to lightning and other forms of broadband interference.

#### BASIC TECHNIQUES AVAILABLE FOR INTERFERENCE CONTROL

In its most elementary form an interference control problem reduces to a source of interference, a potential victim, and the intervening space and structure as shown in Fig. 1. If the source can be eliminated or if the victim can be rendered immune, the problem is solved. Generally, however, as in the case of lightning, the engineer is powerless to affect the source. Similarly, the sensitivity of the victim usually cannot be changed appreciably. Thus, one is left with modification of the coupling path as the primary viable interference control technique.

Fig. 2 shows the three general methods by which electromagnetic waves emanating from the source can be prevented from coupling to, and interacting with, the victim:

- (1) The separation between the source and victim is made infinite (Fig. 2a).
- (2) The sensitivity of the victim is

orthogonal (i.e., cross polarized) to the source (Fig. 2b).

- (3) The source and the victim are separated by an electromagnetically impervious barrier (Fig. 2c).

All passive interference control techniques that do not operate directly on the source rely on one or more of these methods. Separation and orthogonalization can, in fact, be incorporated into the barrier concept. Therefore, of the three listed concepts, the barrier concept is the most fundamental one, and is the one we will consider here. (The ideal conditions listed above are only approximated in practice, but this does not detract from the utility of these concepts since perfect isolation is rarely needed.)

For practical reasons, it is found that the barrier cannot be a closed, flawless shield. In general, the shields will have imperfections such as those illustrated in Fig. 3. The penetrating conductor guides waves to the interior of the barrier, and the aperture and the joint in the shield also allow excitation of the interior.

Thus, the designer must devise ways to close off the openings and imperfections in the shield to achieve an impervious barrier. An example of a fruitful way of thinking about the problem is shown in Fig. 4. In Fig. 4(a), the surge limiter in its normal condition allows current to flow unimpeded along the penetrating conductor to the protected circuit. If a surge occurs that exceeds the threshold voltage, the surge arrester fires and closes the barrier as shown in Fig. 4(b), and diverts the surge current to the outside surface of the shield. Accordingly, a surge arrester may be thought of as a device that closes the barrier when the signal amplitude on a penetrating conductor exceeds a predetermined level. Similarly, a filter may be thought of as a device that closes the barrier at all frequencies outside the passband. Conceptually, the barrier is an electromagnetically closed surface composed of a number of various elements, e.g., filters, surge limiters, metal meshes, joint bonds, etc., in addition to the metallic shield.

The various elements of a typical barrier are shown in Fig. 5. Here, the principal natural boundary of the barrier is defined by the metal case of the system. Bonding is applied at the joint, and the circular opening is filled with one of several possible aperture treatments to assure closure of the surface. An appendage system is included in the barrier by connecting the two systems with a closed conduit. The penetrating conductor is treated using a filter, limiter, and/or isolator. It is very important to note that the ground wire has not been allowed to penetrate the barrier. Instead, the external ground is connected to the exterior of the case. Internal ground

\*Numbers in parentheses designate References at end of paper.

connections are returned to the interior of the case. In this way, noise currents induced on the external ground by lightning and other transient sources are not carried to the interior of the barrier.

For a number of reasons, it is not desirable to achieve all of the required isolation between the source and the victim by means of a single, high-performance barrier, especially when isolation of 60 dB or greater is required. Usually, it is preferable to use two or more less perfect barriers nested one inside the other as indicated in Fig. 6. Here, the outer barrier is defined by the skin of the aircraft. The second barrier level is the equipment cabinet, and the third barrier level is a shielded box within the cabinet. The successive barriers enclose progressively more benign topological zones ranging from the harsh environment in the untreated region of Zone 0 to the triply-shielded environment of Zone 3.

Penetrating conductors are treated at every level, and great care is taken to prohibit ground conductors from penetrating barrier surfaces.

#### GROUNDING ANOMALIES AND THEIR CONSEQUENCES

Many grounding anomalies and interference problems result from expecting the grounding system to perform inappropriate functions substantially beyond its capability. The development of grounding practices evolved in connection with consideration of safety for personnel, equipment, and buildings. The National Electric Code (NEC) definition of grounding is as follows:

"Grounding: A conducting connection, whether intentional or accidental, between an electric circuit or equipment and the earth, or to some conducting body that serves in place of the earth."

Note that grounding does not necessarily involve a connection to earth. For example, systems in the aircraft of Fig. 6 operate quite well when the aircraft is airborne and the earth connection is broken even when the aircraft is struck by lightning and its potential is raised to millions of volts.

Standard functions of grounding are shown in Fig. 7. By conducting away fault currents in (a), the ground system protects personnel from shock or electrocution. In (b), the ground system prevents the accumulation of static charge on elements of a facility thereby avoiding shock to personnel or damage to components that might otherwise be overstressed. Finally, in (c), the ground system reduces the differences in potential between the objects constituting a facility. It should be noted that these functions of a grounding system are achieved in the topologically zoned system of Fig. 6. However, ground wires do not cross topological zones but are generated anew on each side of the barrier.

Grounding gradually began to be associated

with the additional role of interference control sometime after World War II. Today many engineers believe that they can "ground out" interference. In this same context, they feel that a shield should be "grounded" when, in fact it should be closed.

Some of these attitudes stem from certain of the misconceptions regarding ground systems illustrated in Fig. 8. In (a) we see that the ground system cannot be expected to prevent potential rise. A practical ground system has a non-zero impedance (ohms or tens of ohms) so that the currents associated with a lightning stroke will raise the potential of the external ground terminal to thousands of volts. Even nearby lightning produces substantial pulses in the ground terminal. Thus, any system whose proper functioning depends on a zero-impedance ground connection is doomed to failure. Such a design is also entirely inappropriate because the systems of the aircraft of Fig. 6 operate perfectly well with an infinite-impedance earth connection when the aircraft is airborne.

In Fig. 8(b), we note that the ground system cannot provide an infinite current sink for noise signals originating within the system. Here, again, the non-zero impedance of the ground connection and of the grounding system wiring implies that noise currents within the system can generate substantial voltages on the grounding system.

Finally, in Fig. 8(c), we observe that simple grounding of the source does not control interference at the victim. As is discussed in a comparison paper<sup>(3)</sup>, the "grounding" of shields to control interference is better considered as an effort to "close the barrier" around the victim system.

One of the consequences of permitting a ground conductor to penetrate the barriers surrounding a system is illustrated in Fig. 9. From the foregoing discussion, we note that the ground wire cannot be treated as a benign entity capable of extracting all of the noise from a system. Instead, it must be recognized as a conductor that can carry noise from the harsh exterior environment to the interior. Thus, topologically, the penetrating ground conductor transforms the doubly-shielded volume into an unshielded volume.

A further consequence of an ill-conceived grounding system is shown in Fig. 10. Here, we note that the "signal reference ground" has been brought out through one or more layers of shielding and connected to the facility ground rod. Also connected to the ground rod are the power neutral (white wire) and the safety ground (green wire). Switching the power circuits within the facility induces transients in the power ground wiring. Since the ground is not an infinite current sink, a portion of the transient current will flow on the signal reference ground directly to the low-level circuitry within the system. Essentially, the grounding system of Fig. 10 serves to collect the transients generated within the system and apply them to the most susceptible circuits.

Some commonly encountered grounding anomalies are illustrated in Figs. 11(a), (c), and (e). In Fig. 11(a), the building shield is violated by routing a separate ground wire from the equipment cabinet to the earth electrode outside the building, thus contaminating the building environment. More serious violations are illustrated in Figs. 11(c) and (e); in these examples, small-signal ground (signal common) is connected to a conductor exposed to the raw outside environment. Although such grounding arrangements have been used, they have been the source of much objectionable interference in digital systems--at least upset and often damage. The correct shielding and grounding topology is illustrated in Fig. 11(b), where it is seen that no grounding conductor penetrates a system shield. An alternative such as that shown in Fig. 11(d) can be used to correct the severe violation of Fig. 11(c), but this is usually a more expensive and less reliable approach. Another acceptable alternative is shown in Fig. 11(f), in which the grounding conductor is continuous through both shields but the hole through which the conductor passes is filled by welding, brazing, or soldering the conductor to the shield material. As in the case of the filtered ground penetration, there is no particular advantage to the continuous conductor fused to the shields; hence, these methods are not usually recommended. Irrational applications of single-point grounding such as those illustrated in Fig. 11(c) have caused equipment damage and high upset rates during thunderstorms. The grounding arrangement of Fig. 11(e) was found to be a probable cause for upset in an EMP environment in a weapon system.

To quantify the degree to which a barrier may be degraded by penetrations, a set of experiments was conducted using the setup illustrated in Fig. 12. A chamber, roughly a cube 2.5 m on a side, made of mild sheet steel 0.8-mm thick was used to establish an arbitrary but well-defined electromagnetic barrier. The seams were bolted together with an equivalent overlap of about 2 cm. The chamber was set up 13 cm above a ground plane of aluminum sheets riveted together. The wall thickness of the chamber was approximately five times the skin depth at 1 MHz. The average shielding effectiveness as measured by the amplitude reduction of a double exponential driving pulse was about 60 dB. While this is not a high-performance barrier, it is perfectly adequate for the experiments described below.

The chamber was driven near the center of one side wall, with the return conductor connected to the center of the opposite wall and the ground plane. A high-voltage pulse generator was used to produce a driving pulse with a rise time of about 40 ns and a decay time of about 2  $\mu$ s so that it had adequate spectral energy in the HF band to simulate modern lightning models.

Many different sensors could have been used to measure the response on the inside of the chamber. We used the largest loop that could be

installed in the chamber. The rationale for this choice of sensor was that it produces a response at least as large as could be obtained on a system conductor in the chamber. Both open-circuit voltage and short-circuit current (peak value) were measured.

To simulate a penetrating ground conductor, the return lead was connected to the inside of the wall using pigtailed of various lengths as is detailed in Table 1. In (a), a small pigtail with a radius of 5 cm was used. The peak value of the short-circuit current induced in the test loop in this configuration was 25 mA, whereas in the basic configuration it was only 5 mA. The open-circuit voltage increased only by a factor of 2, but a large amount of ringing (presumably due to direct coupling between the pigtail and the loop) made an exact reading impossible. The resonance could not be excited when the return conductor was connected to the outside of the chamber, that is, when the barrier was closed.

The dependence of the induced signal strength on the length of the pigtail was investigated using the configurations of (c), (d), and (e) of Table 1. The results of the measurements for these five configurations with a test loop are presented in the table.

The results shown in Table 1 should be interpreted with caution; the numbers represent typical losses in performance, but, of course, they are dependent on the geometry of the entire experiment. However, they can be taken as being indicative of the degree to which a shielded system can be degraded by penetrating ground conductors.

#### SUMMARY AND CONCLUSIONS

Historically, grounding systems were evolved for reasons of personnel safety, and they served primarily to tie together the components making up a system to protect personnel from shocks resulting from static charge accumulation or from ground fault currents. More recently, grounding has emerged as an interference-control technique. Although the application of improper grounding procedures can degrade an otherwise well-designed system, grounding should not be thought of as an interference-reduction technique. For example, one should not expect a grounding system to "ground out" interference. In fact, grounding systems designed with this premise generally serve as "interference distributors" within a facility.





It is possible to design facilities highly immune to lightning interference by applying modern topological zoning concepts. It is necessary to prohibit the penetration of a barrier by an untreated conductor to maintain the integrity of these facilities. Unfortunately, designers frequently consider the ground wire to be at least benign and possibly endowed with magic powers, so that it is allowed to thread its way through all levels of the facility. This procedure is entirely inappropriate; each shielded region (topological zone) should have a separate grounding system

making contact with both the inner and outer shield defining the zone. This approach allows the grounding system to perform its safety function, and it also prevents the distribution of noise from one topological level to the other on the grounding system.

#### REFERENCES

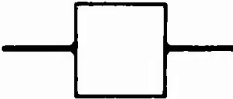
1. E. F. Vance, "Electromagnetic-Interference Control," "IEEE Trans. on Electromagnetic Compatibility," Vol. EMC-22, No. 4, November 1980.
2. W. Graf and E. Vance, "A Topological Approach to the Unification of Electromagnetic Specifications and Standards," "Proc. of the IEEE 1982 National Aerospace and Electronics Conference," May 1982.
3. W. Graf, J. Hamm, and E. F. Vance, "Relative Importance of Electromagnetic Shield Violations," International Aerospace and Ground Conference on Lightning and Static Electricity, June 21-23, 1983.

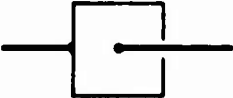
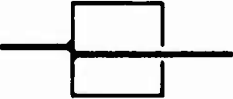
**Table 1 - Loss of Shielding Effectiveness Due to Conductor Penetration**  
 (Open-circuit voltage  $V_{oc}$ , and short-circuit current  $I_{sc}$  are shown for loop 1)

Experiment*		$V_{oc}$	$I_{sc}$
a. Basic Configuration		80 mV	5 mA
b. Pigtail 5 cm Radius		150 mV	25 mA
c. Pigtail 1 m Long		2 V	200 mA
d. Pigtail 2 m Long		16 V	0.6 A
e. Pigtail 4 m Long		>16 V	1.5 A

\*The setup is shown schematically. Only the location of the ground return is varied. In all but the first experiment the driver was connected to the outside of the shield and the return to the inside of the shield as shown.

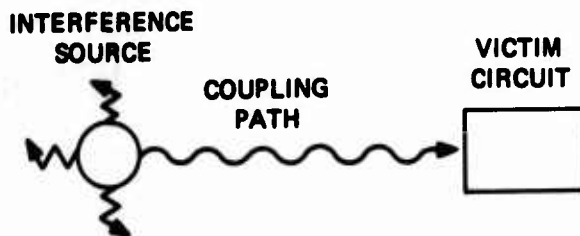

**Fig. 1 - Schematic characterization of the interference coupling process**

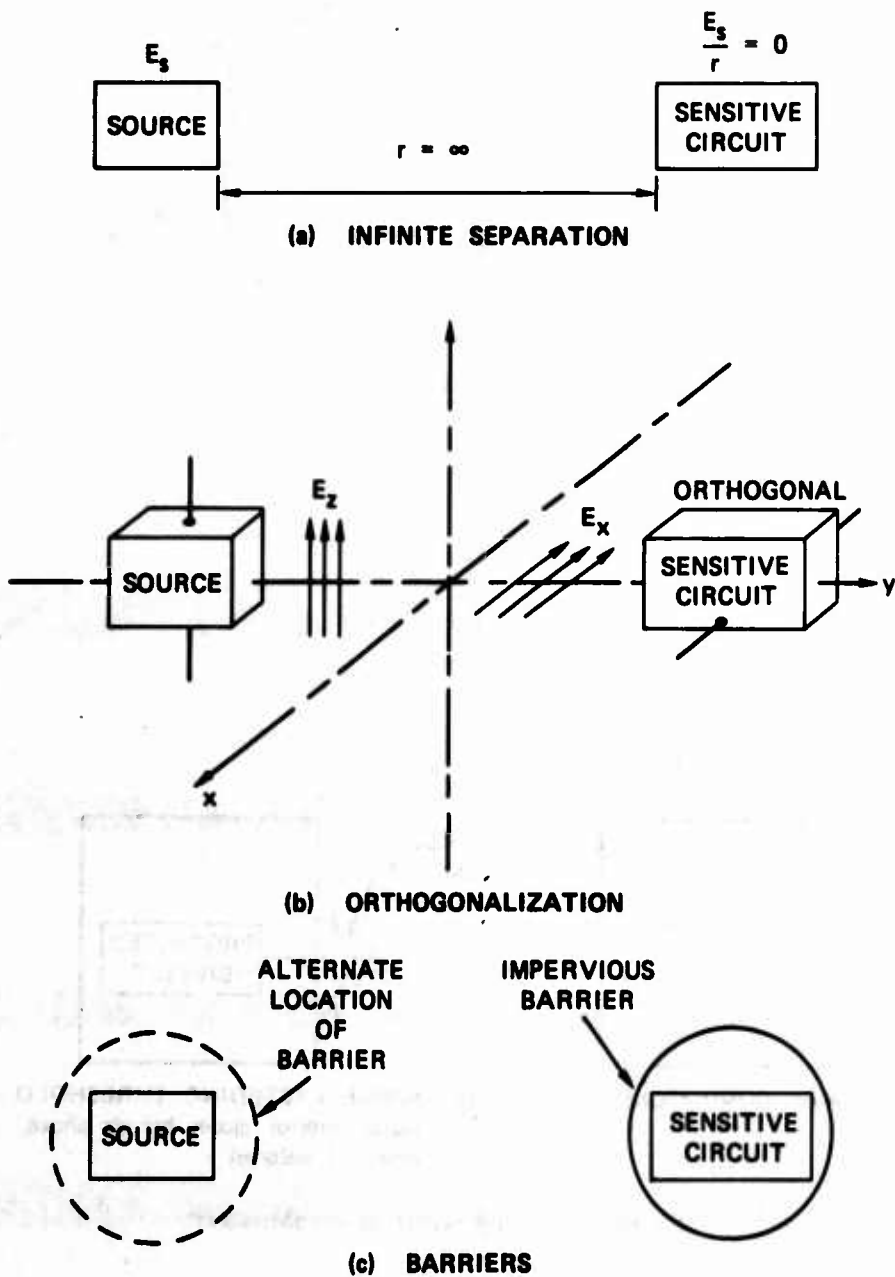

Fig. 2 - Methods of eliminating the interaction of an interference source with a sensitive circuit

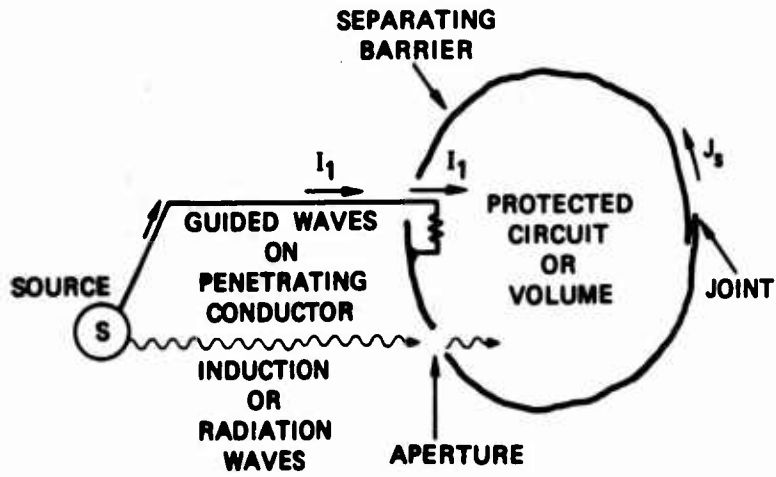

Fig. 3 - Typical imperfections in a practical barrier

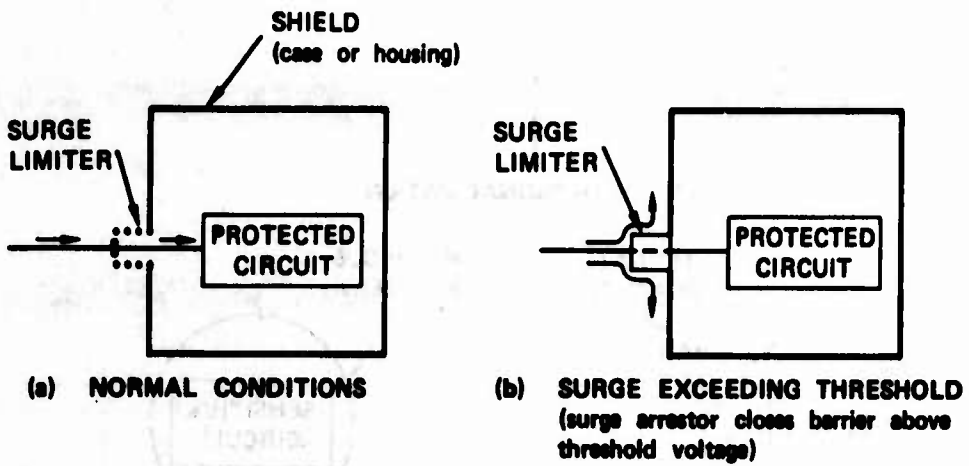

Fig. 4 - Concept of closing barrier at a penetration

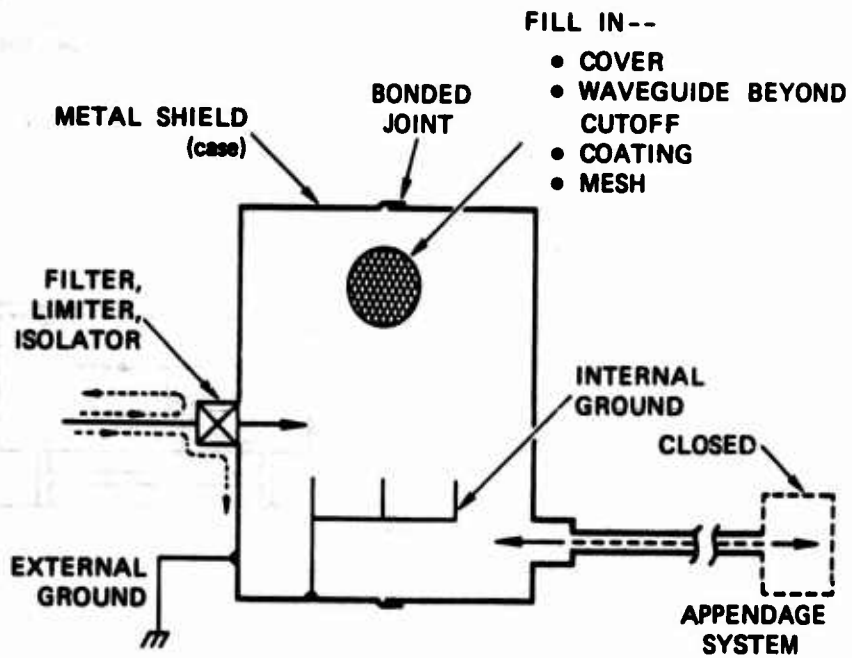

Fig. 5 - Elements of a typical closed electromagnetic barrier

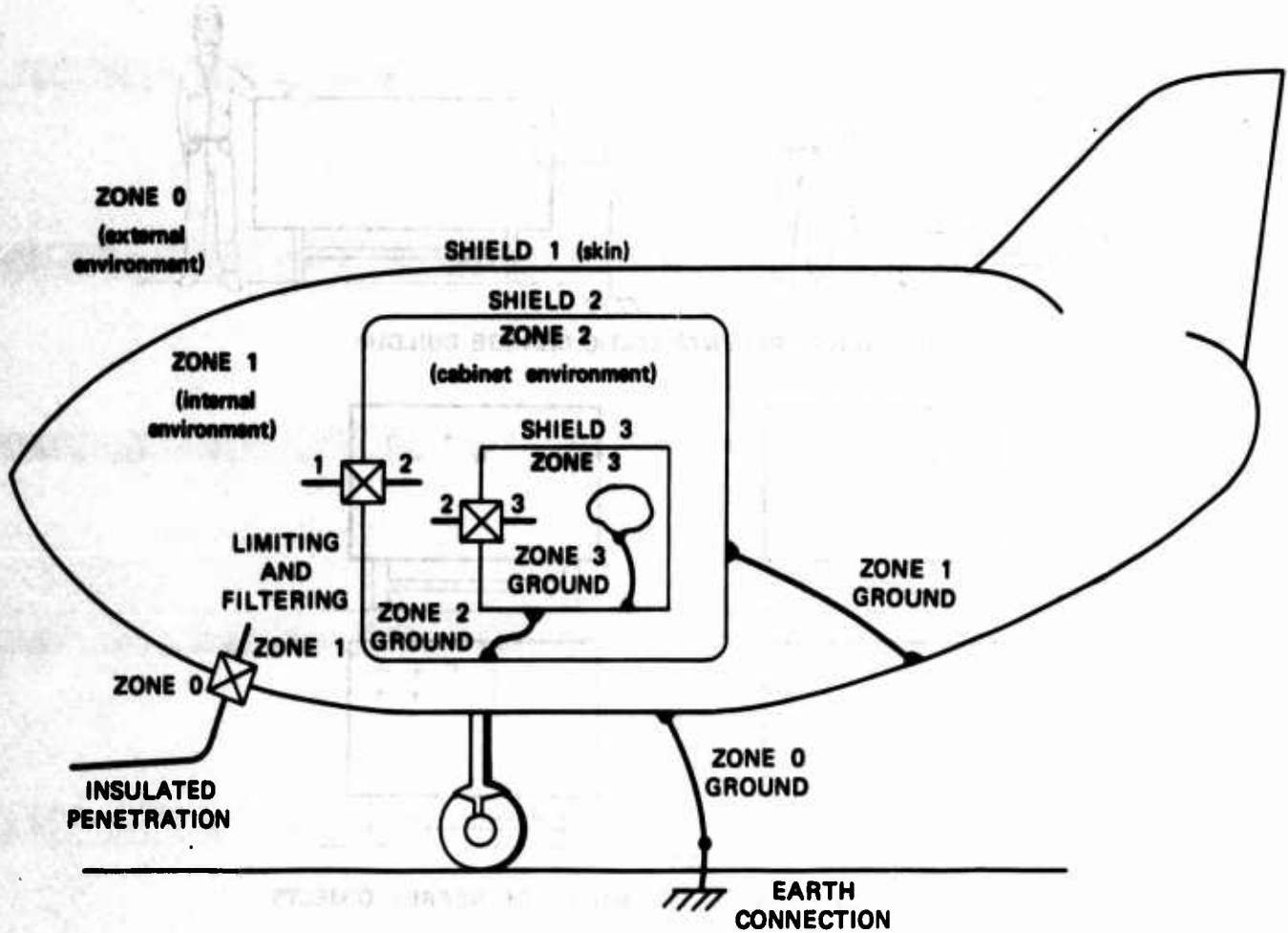
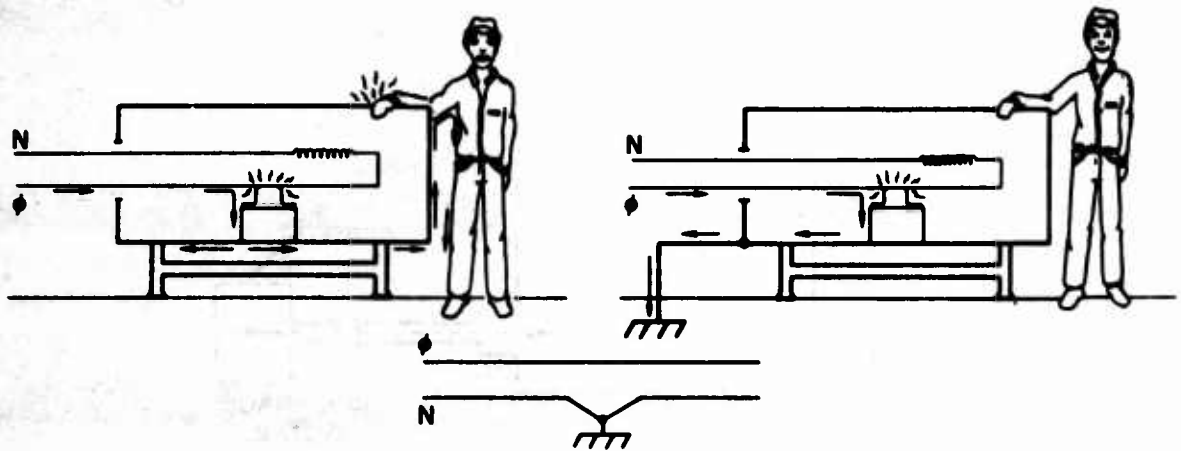
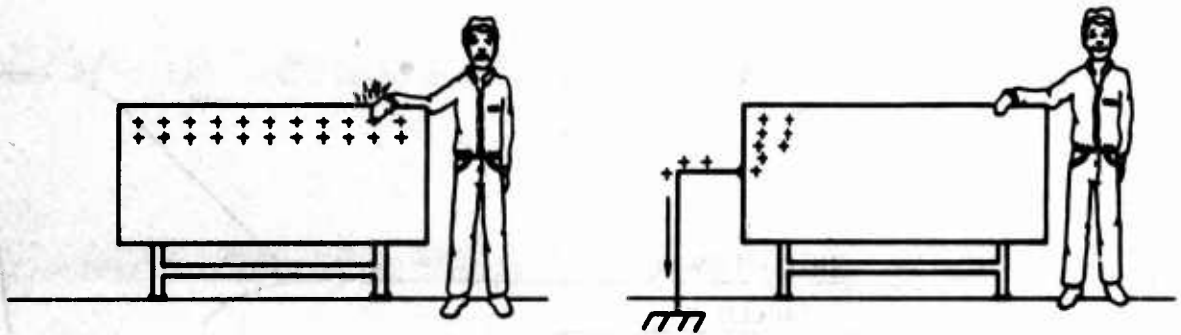

Fig. 6 - Environmental zones in a complex facility such as an aircraft



**(a) GROUNDING PROVIDES A PATH FOR FAULT CURRENTS**



**(b) GROUNDING PREVENTS STATIC CHARGE BUILDUP**

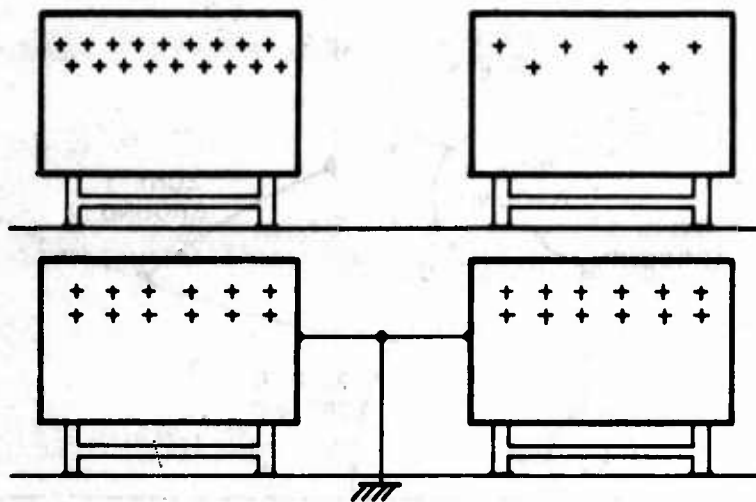

**(c) GROUNDING CAN EQUALIZE POTENTIALS OF NEARBY OBJECTS**

**Fig. 7 - Appropriate functions for a grounding system**

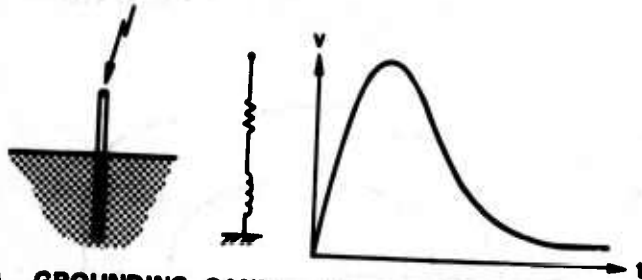

(a) **GROUNDING CANNOT PREVENT POTENTIAL RISE**

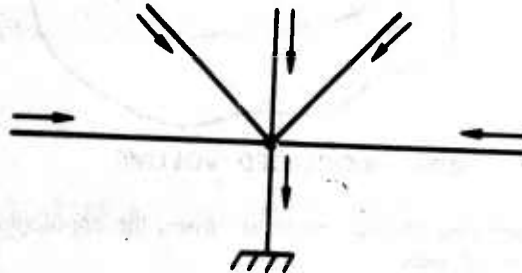

(b) **GROUNDING CANNOT PROVIDE INFINITE CURRENT SINK**

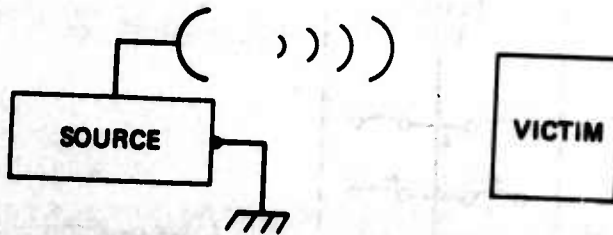

(c) **GROUNDING SOURCE OR VICTIM STRUCTURE DOES NOT CONTROL INTERFERENCE**

Fig. 8 - Some popular misconceptions regarding grounding

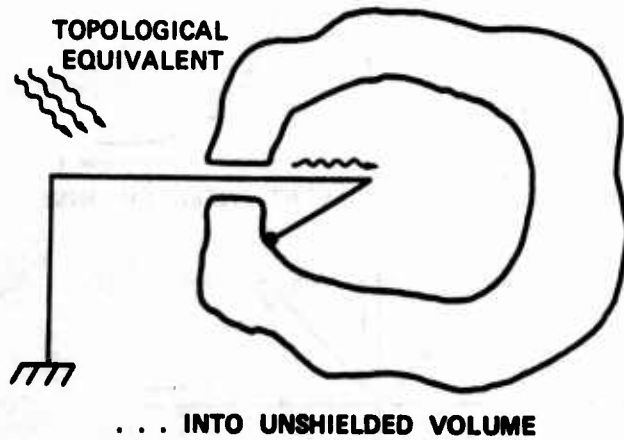
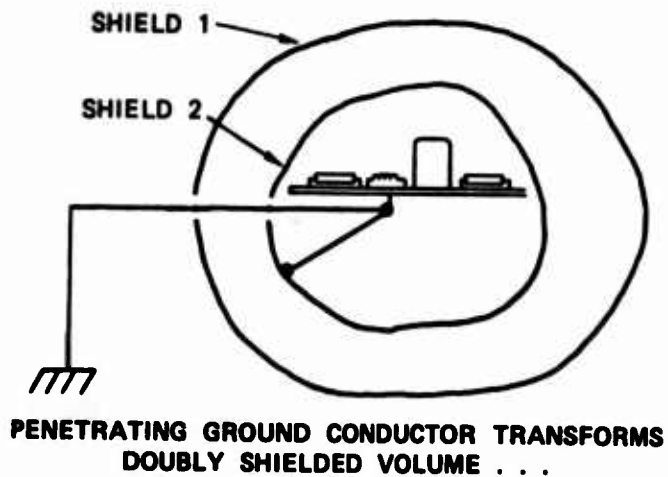

Fig. 9 - Penetrating ground connector from the topological point of view

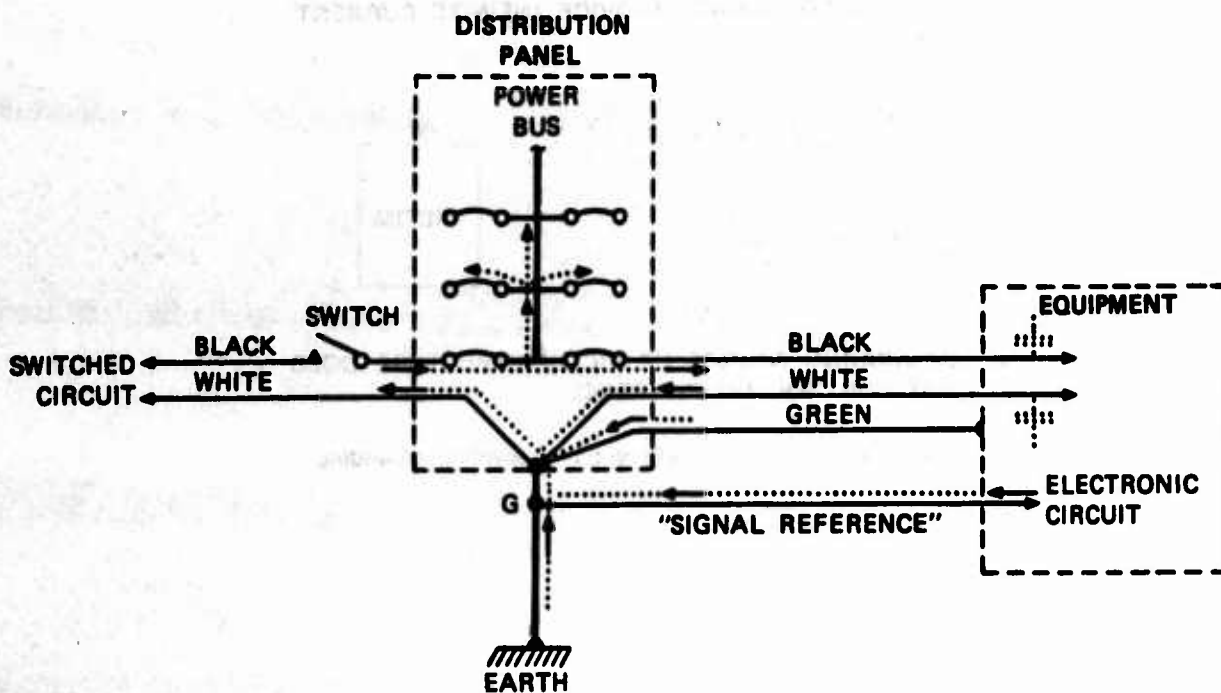

Fig. 10 - Interference distribution through an ill-conceived grounding system

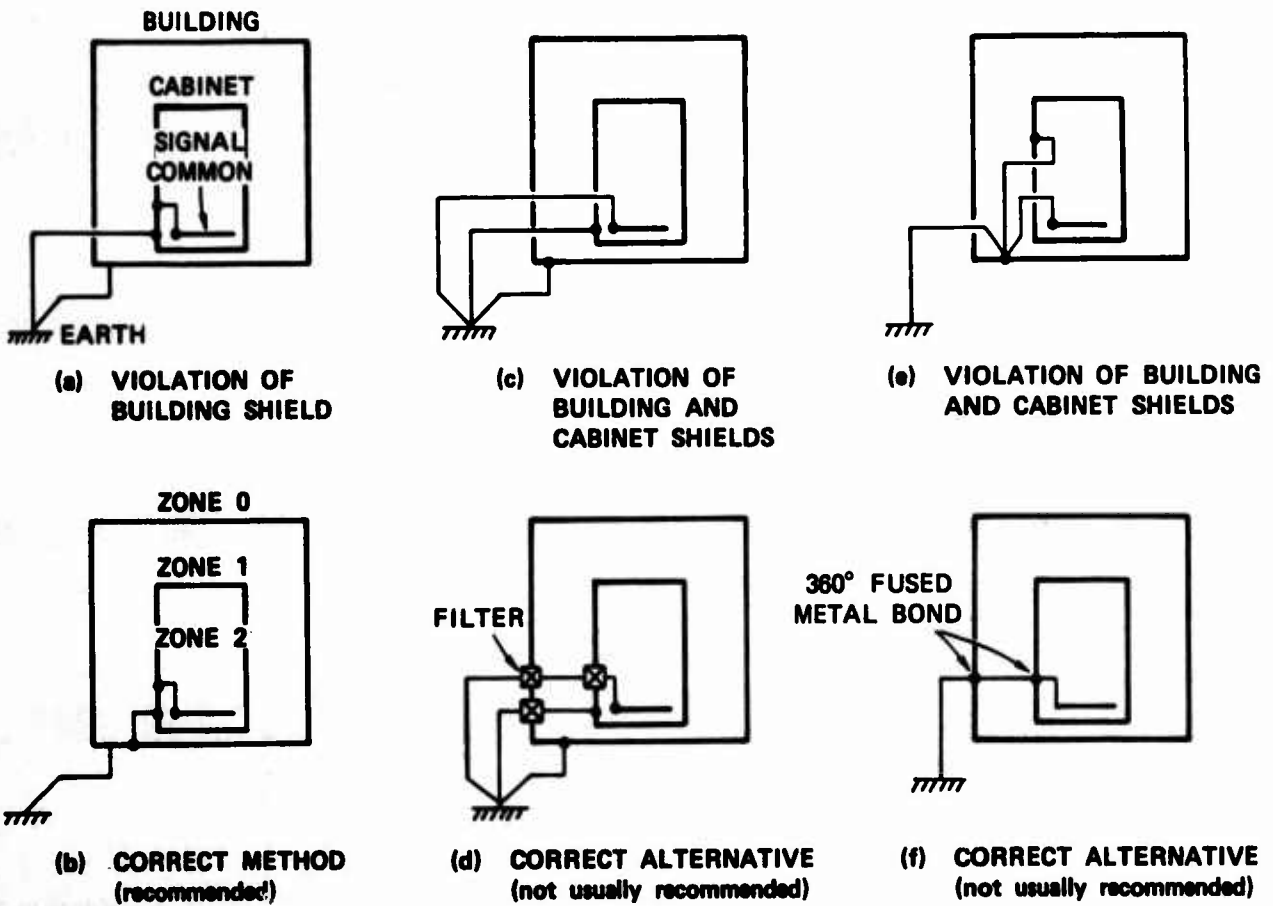

Fig. 11 - Typical grounding anomalies encountered in practice and some correct alternatives

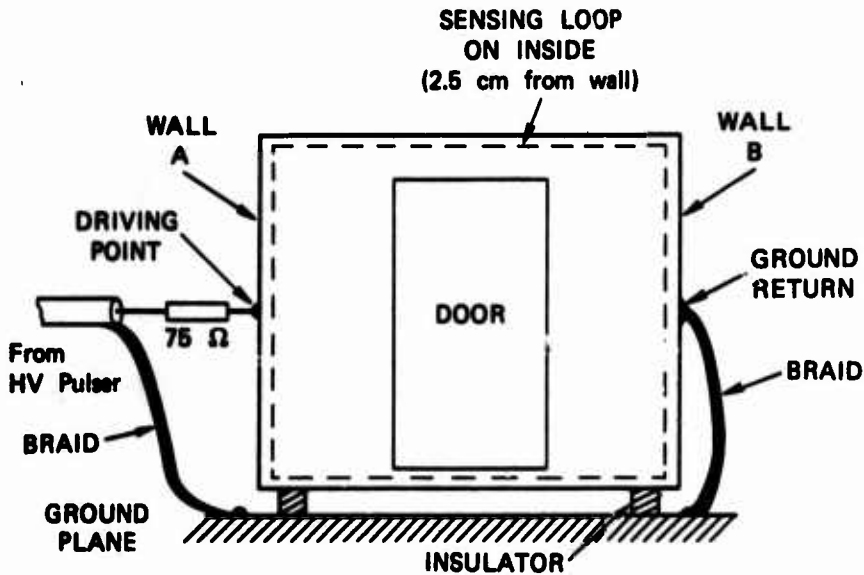

Fig. 12 - Test setup for penetration experiments

