

AD P 002182

EARTH ELECTRODES FOR GROUNDING NEMP TYPE LIGHTNING

David P. Millard
Georgia Institute of Technology, Atlanta, Georgia

ABSTRACT

An investigation was conducted into the properties of earth electrode systems over a frequency range covering the NEMP type lightning (rise times faster than 2 microseconds) power spectrum. Since this power spectrum extends well into the VHF region, conventional low frequency (less than 100 Hz) and historic impulse measurement techniques were not adequate to describe the electrode system's response to NEMP type lightning. Therefore, initial emphasis was placed on the development of a measurement technique that could be used to both: (1) Assess the performance of a given ground electrode; and (2) conduct a site survey to determine the best location for ground electrodes. Then the technique was used to evaluate the performance of various common ground electrode configurations (the subject of a companion paper to be published at a later date).

THE RESPONSE OF AN EARTH ELECTRODE to an NEMP type lightning pulse is determined by the properties of the soil and the electrical characteristics of the particular electrode system geometrical configuration. Thus, the first step in establishing an adequate ground is to determine the dielectric properties (conductivity, permittivity, and permeability) of the soil. (This step is important because it dictates the geometrical configuration (i.e., number of ground rods, method of interconnection, etc.) required to establish a good ground in a given area.)

Historically, soil parameter identification started with a laboratory analysis of soil samples and then moved to sophisticated on-site analyses of the soils and underlying strata at the planned location. Recent advances in on-site techniques have been made. One of these, the Resonant Linear Antenna Method [1] appears to be the most suitable for NEMP type lightning grounding studies. (The method is accurate over a broad frequency range, is easily transportable, and is generally in use by geophysicists for geological surveying.) From the input admittance and the geometry of a probe antenna, the soil parameters can be calculated. This method requires only a resonant monopole antenna, a signal source covering the desired frequency range, and a display device complete with necessary coaxial voltage and current probes. An adaption of this technique was employed to examine the behavior of selected earth electrodes up to frequencies reflective of fast risetime responses applicable to NEMP type lightning waveforms.

The grounding of power circuits (25-60 Hz) and grounding for lightning protection (impulse) is the primary concern for structures and power lines. Thus, many studies were performed to determine the volt-ampere characteristics of a driven ground rod using direct current or low frequency (< 100 Hz) alternating current instruments to determine power frequency properties [2]. Impulse generators were used to determine the response to lightning strokes [3].

The typical impulse generator was capable of producing 50 KV and 800 A with a 1 to 2 microsecond rise time. From these tests, a resistive, inductive and capacitive (RLC) model of a ground rod was developed [4] (Figure 1) that reflected the geometry of the rod, the soil parameters, and the climatic conditions at the time of the test.

Within the last several years lightning pulses faster than the traditional 2 microsecond rise time have been recorded [5]. Thus, development of a new technique for measuring ground electrode impedances at these extended frequencies was necessary. After careful consideration of existing instrumentation capabilities, it was determined that a technique could be devised to display the response of an electrode system up to 500 MHz which covers the NEMP type lightning and much of the NEMP spectrum (Figure 2). Three different measurement techniques must be used to cover the entire frequency range from DC up to 500 MHz. The frequency ranges covered by each are: (1) low (DC to 100 Hertz), (2) medium (100 Hz to 500 KHz), and (3) high (500 Hz to 50 MHz). The design and construction of a standardized test probe along with a description of the test techniques for these three frequency regions are discussed in the next sections.

STANDARD TEST PROBE

A rod of 1.25 cm (0.5 inches) in diameter and 81 cm (32 inches) in length was chosen for the standard test probe. (Brass was used although steel, copper, or any other metal of sufficient strength is adequate.) This length is long enough to provide effective soil contact but not so long as to require extensive work to place the rod in the ground.

An adapter was then constructed to interface the ground rod to the test instruments (see Figure 3). The adapter consists of a tapered coaxial line transition with a male type N connector on the top. The taper maintains 50 ohms impedance down to the point of attachment to the rod. (The impedance characteristics of the connector from

0.5 to 500 MHz are shown in Figure 4.) The adapter is fastened to the ground rod via a threaded connection.

HIGH FREQUENCY MEASUREMENTS

The high frequency impedance characteristics of the test probe were measured with the aid of a General Radio 1710 RF Network Analyzer. The analyzer was connected to the type N connector as shown in Figure 3, calibrated (Figure 5), and an impedance plot of the probe in earth was photographed (see Figure 6). It is noted that there is a great deal of ringing associated with both the magnitude and phase of the rod impedance. The ringing is due to the non-uniform imaging of the rod with the soil, the inductance and capacitance of the test leads to earth, and the standing waves at the surface [6]. By increasing the reference plane area of the probe, the standing waves and reflections were reduced, yielding a more acceptable plot of the ground rod impedance. The reference plane area was increased by attaching auxiliary grounds and an aluminum plate to the test connector shield (see Figure 7). A series of plots, Figures 8 to 13, were taken with different auxiliary grounds. The figures reveal that the rod impedance ringing decreased and displayed an overall capacitive nature at high frequencies as expected. These results indicated that this approach can be used to determine the impedance of the reference probe up to frequencies of 500 MHz. From this impedance characteristic, determination of the equivalent circuit of the probe can be made [7].

A computer run was made to calculate the input impedance of the equivalent circuit (Figure 1) with the test rod geometry and soil conditions of the particular test area. The input impedance of the ground rod equivalent circuit is given by:

$$Z = \frac{Z_L Z_C}{Z_L + Z_C} \quad (1)$$

where

$$Z_L = R + j \omega L$$

$$Z_C = \frac{1}{j \omega C}$$

$$R = \frac{\rho}{2 \pi \ell} \ln \frac{2 \ell}{a} \quad \text{ohms}$$

$$L = 2 \ell \ln \frac{2 \ell}{a} 10^{-7} \quad \text{H}$$

$$C = \frac{\epsilon_r \ell}{2 \ln 2 \ell} \frac{10^{-9}}{9} \quad \text{F}$$

ℓ = length of rod

a = radius of rod

ρ = 97.67 Ω m

$10 < \epsilon_r < 13$

A graph of the results is shown on Figure 14. For this second order system, the resonant frequency is approximately 15 MHz. The response of the final test configuration (Figure 13) reveals a resonance around 8 to 9 MHz with ringing from 100 to 500 MHz.

LOW FREQUENCY MEASUREMENTS

The impedance of an earth electrode at low frequencies is dominated by the properties of the soil. Analytically the resistance of a ground rod can be determined if the soil resistivity, ρ , and the rod geometry are known, i.e.,

$$R = \frac{\rho}{2 \ell} \ln \frac{2 \ell}{a} \quad \text{ohm} \quad (2)$$

where ℓ = length of the rod and a = its radius.

Experimentally the ground rod resistance was accurately measured by the Fall-of-Potential Method (see Figure 15) [8]. This is a simple voltage drop measurement relating the current injected to the resistance of the ground rod. (The injected current usually has a frequency of 70 to 100 Hz so as not to be confused with stray 60 Hz ground currents.) The ground rod resistance

was found by recording the resistance on a Biddle Meggar-Earth Tester* as distance, d (distance between the ground rod and probe C_2), was varied. The potential probe, P_2 , must be placed 62% of d , between the ground rod and probe C_2 . By using this method a plot was made of ground rod resistance versus separation distance, d (see Figure 16). From this graph the test ground rod resistance was determined to be 107 ohms.

The four probe technique can also be used to find soil resistivity, ρ . The resistivity of the soil at the test site was measured using the test setup shown in Figure 17. This resistivity was determined to be 97.67 ohm-meter. With this resistivity, the resistance of the ground rod should be 98.6 ohms, which is within 10% of the Fall-of-Potential Method. (This result is considered to represent reasonable accuracy, given the high degree of dependence of the tests on environmental conditions.)

MID-FREQUENCY MEASUREMENTS

The mid-frequency range, 100 Hz to 500 KHz, impedance measurement proved to be the most difficult to obtain because of instrumentation limitations. Most off-the-shelf impedance measuring devices require that the object of the test not be grounded. (Specifically the HP 4800A Vector Impedance Meter has "DO NOT GROUND" printed under the input terminals.) Therefore, measuring the impedance of a grounded rod proved impossible with this type of instrument.

An approach was developed which relied strictly on network theory and the fact that the magnitude of the impedance is equal to the ratio of the magnitude of the voltage across and the current through the rod. Several attempts were made to obtain a suitable measurement. Since most oscilloscopes use "ground" as a reference and have a high impedance input, there was no problem with making voltage measurements on the source end of the ground rod. A problem arose in trying to

measure the current into the ground rod, however. The first approach was to measure the voltage drop across a one ohm resistor in series with the ground rod. Problems were encountered when the oscilloscope probe shield was connected to the terminal of the resistor thereby adding another "ground" to the circuit. Attempts were made to isolate the oscilloscope from ground, but this only served to increase the noise in the measurement. Obviously, a method of measuring the current was needed which would provide isolation from ground and provide noise rejection.

An HP current probe and amplifier provided just such a solution (see Figure 18). This test setup worked well in measuring the ground rod impedance over the mid-frequency range. The results match the low and high frequency impedance measurement of the rod and allowed measurements of impedance over the low end of the NEMP type lightning spectrum. Figure 19 is a plot of the test probe impedance to ground using the mid-frequency setup. The highest frequencies are compared to the high frequency test and the results are within the measurement error.

The test procedure consisted of varying the frequency of the HP 651A Test Oscillator, while maintaining constant output voltage, and measuring the voltage at the terminal of the ground rod and the current through the lead to the ground rod. The test probe configuration was the same as for the high frequency measurements technique. The ground plate and auxiliary ground points were used to provide an effective reference contact with the soil.

SUMMARY

This research has demonstrated how difficult it is to predict and measure the high frequency characteristics of a ground electrode. Without the aid of a network analyzer the impedance of a ground electrode is hard to measure at high frequency. The impedance will vary greatly with the parameters of the soil and the environmental conditions. At high frequencies the coupling mode

*James G. Biddle Co., Plymouth Meeting, PA 19462

for the earth electrode is capacitive, therefore, the contact area at the ground surface should be as large as possible (relative geometric mean area) to dissipate an, transient energy.

ACKNOWLEDGEMENTS

This work [9] was sponsored by the Defense Nuclear Agency under RDT&E RMSS Code B3630 80462 G52AAXEX40602 H2590D contract number DNA001-80-C-0294 and performed by the Engineering Experiment Station of the Georgia Institute of Technology, Atlanta, Georgia 30332.

REFERENCES

1. Smith, G. S., and King, R. W. P., "The Resonant Linear Antenna as a Probe for Measuring the In Situ Electrical Properties of Geological Media", Journal of Geophysical Research, Vol. 79, No. 17, June 10, 1974, pp. 2623-2628.

2. Curdts, E. B., "Some of the Fundamental Aspects of Ground Resistance Measurements", AIEE Transactions, Communications and Electronics, Vol. 77, No. 39, November 1958, pp. 767-770.

3. Gaddy, O. L., "A Simple Method of Measuring Fractional Millimicrosecond Pulse Characteristics", IRE Transactions on Instrumentation, Vol. 1-9, No. 3, December 1960, pp. 326-333.

4. Mukhedkar, D., Gervais, Y., and De Jean, J. P., "Modeling of a Grounding Electrode", IEEE Transactions on Power Apparatus and Systems. Vol. PAS 92, No. 1, January-February 1973, pp. 295-297.

5. Weidman, C. D. and Krider, E. P., "Submicrosecond Rise Times in Lightning Radiation Fields", Proceedings of the Lightning Technology Symposium, sponsored by the FAA and NASA at NASA Langley Research Center, Hampton, VA, April 22-24, 1980.

6. Lee, K. M., and Smith, G. S., "Measured Properties and Insulated Antennas in Sand", IEEE Transactions on Antennas and Propagation, Vol. AP-23, No. 5, September 1975, pp. 664-70.

7. Lytle, R. J., "Properties of the Ground Inferred from Electromagnetic Measurements", IEEE Transactions on Antennas and Propagation, Vol. AP-27, No. 6, November 1979, pp. 899-902.

8. Denny, H. W., Holland, L. D., Robinette, S. L., and Woody, J. A., "Grounding, Bonding, and Shielding Practices and Procedures for Electronic Equipments and Facilities," Volume 1, Final Report, Contract DOT-FA72WA-2850, Engineering Experiment Station, Georgia Institute of Technology, December 1975, AD A022 332.

9. Denny, H. W., Acree, D. W., Melson, G. B., and Millard, D. P., "Supplemental Grounding of Extended EMP Collectors", Georgia Institute of Technology, Engineering Experiment Station, for the Defense Nuclear Agency, 31 January 1982.

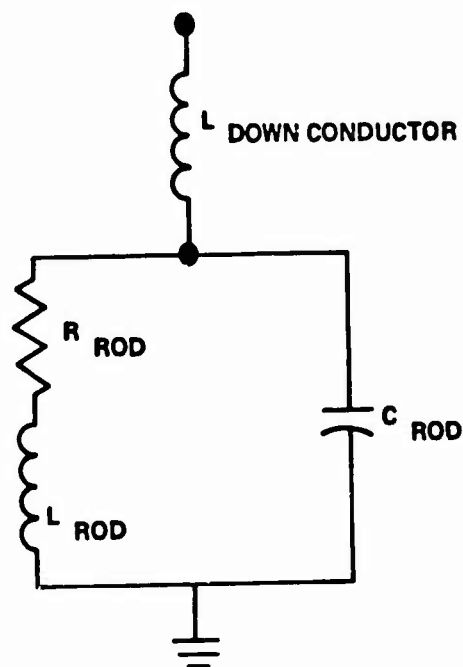

Fig. 1 - Ground rod model.

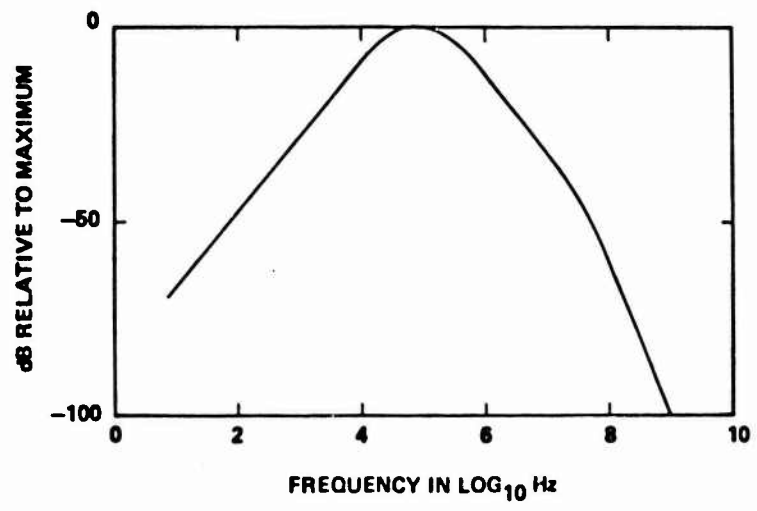
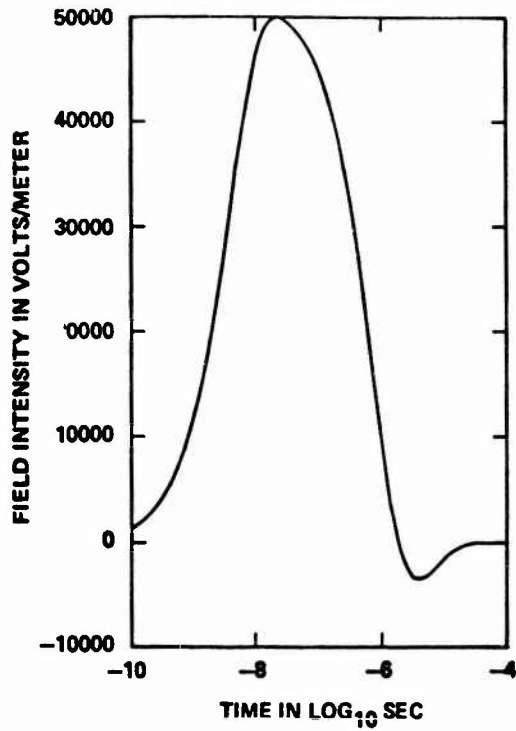

Fig. 2 - EMP time waveform and power spectrum representations.

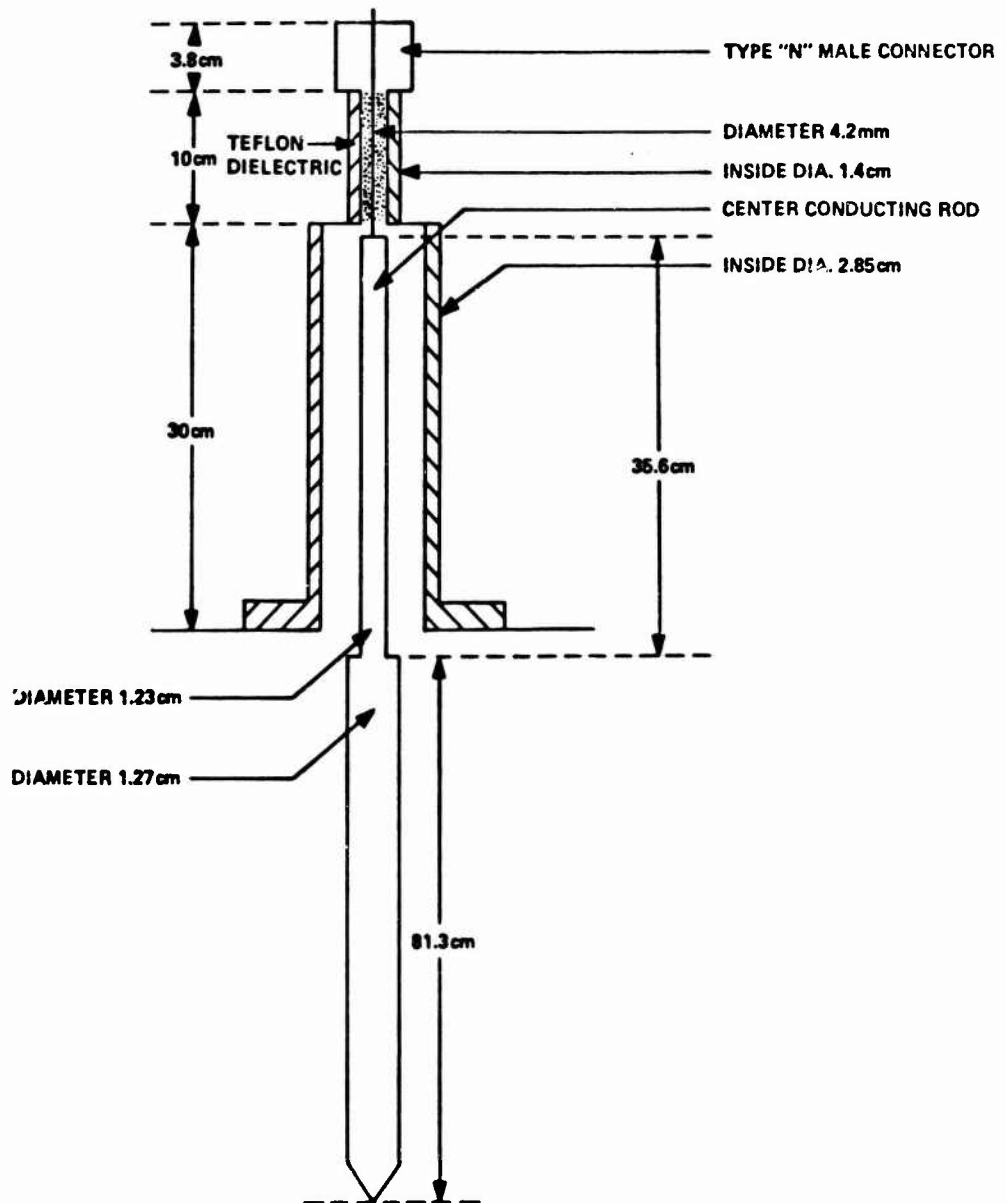

Fig. 3 - Standard test probe details.

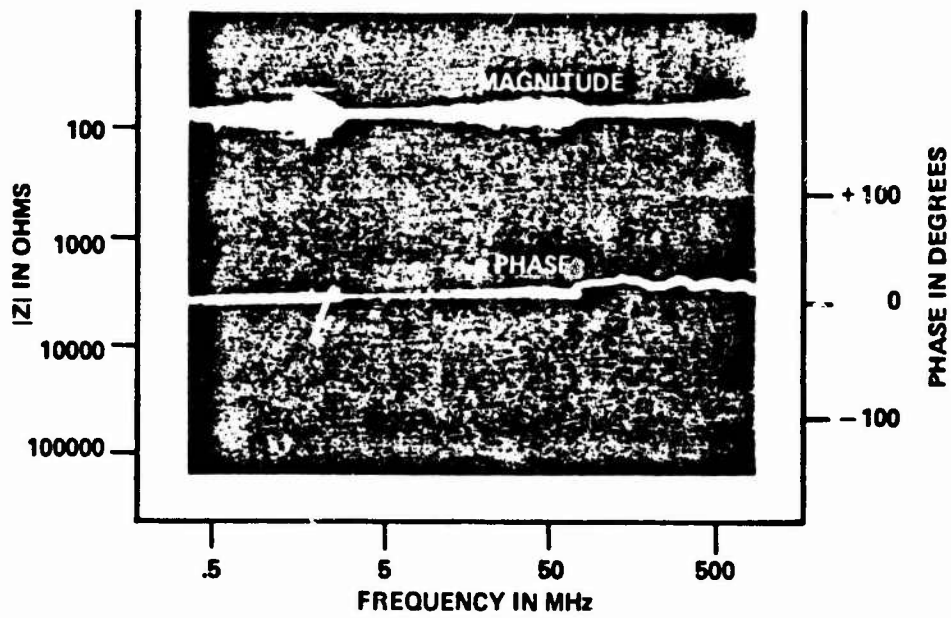

Fig. 4 - Connector input impedance.

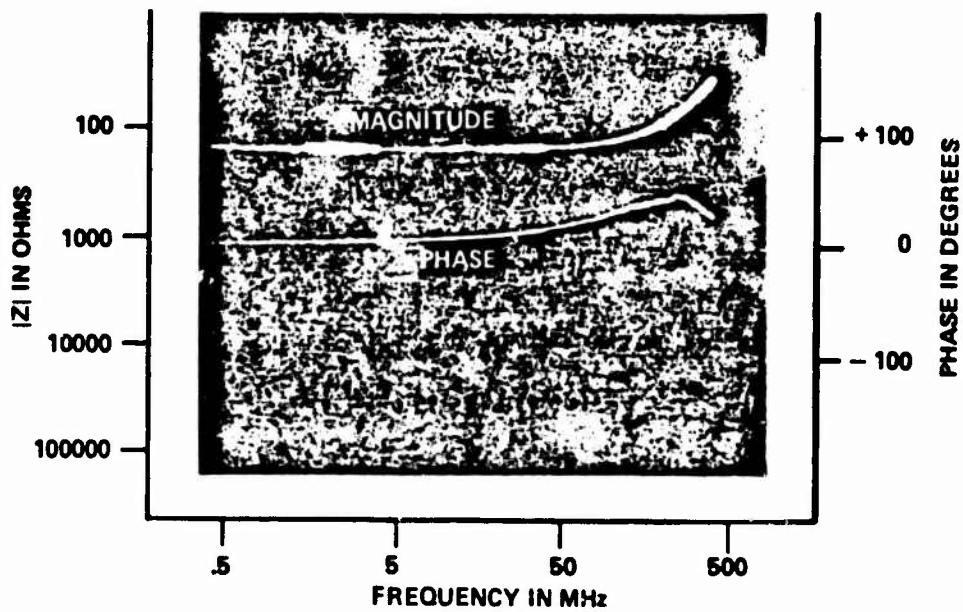

Fig. 5 - Connector output impedance for calibrated 100 ohm load.

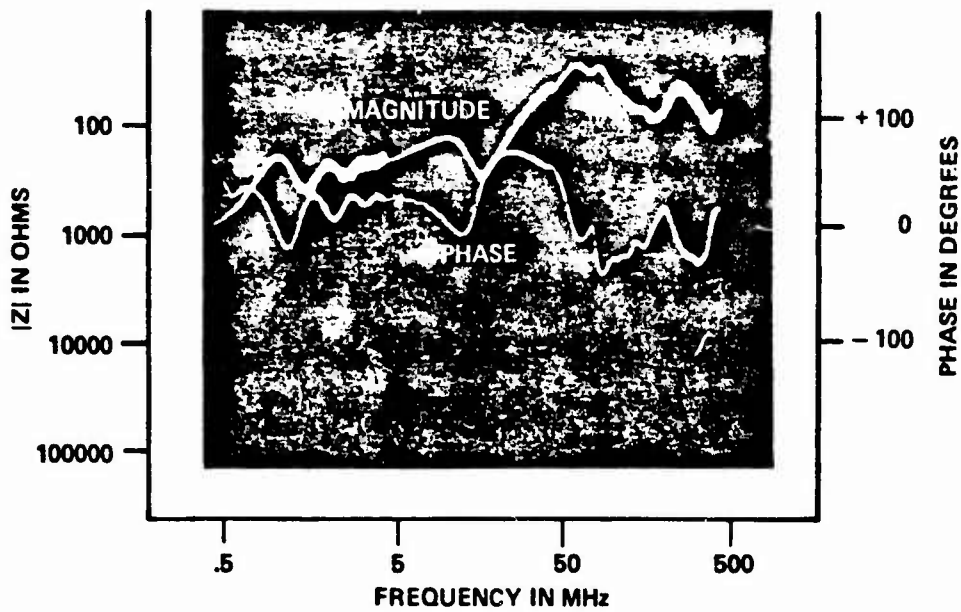

Fig. 6 - Simple ground rod impedance.

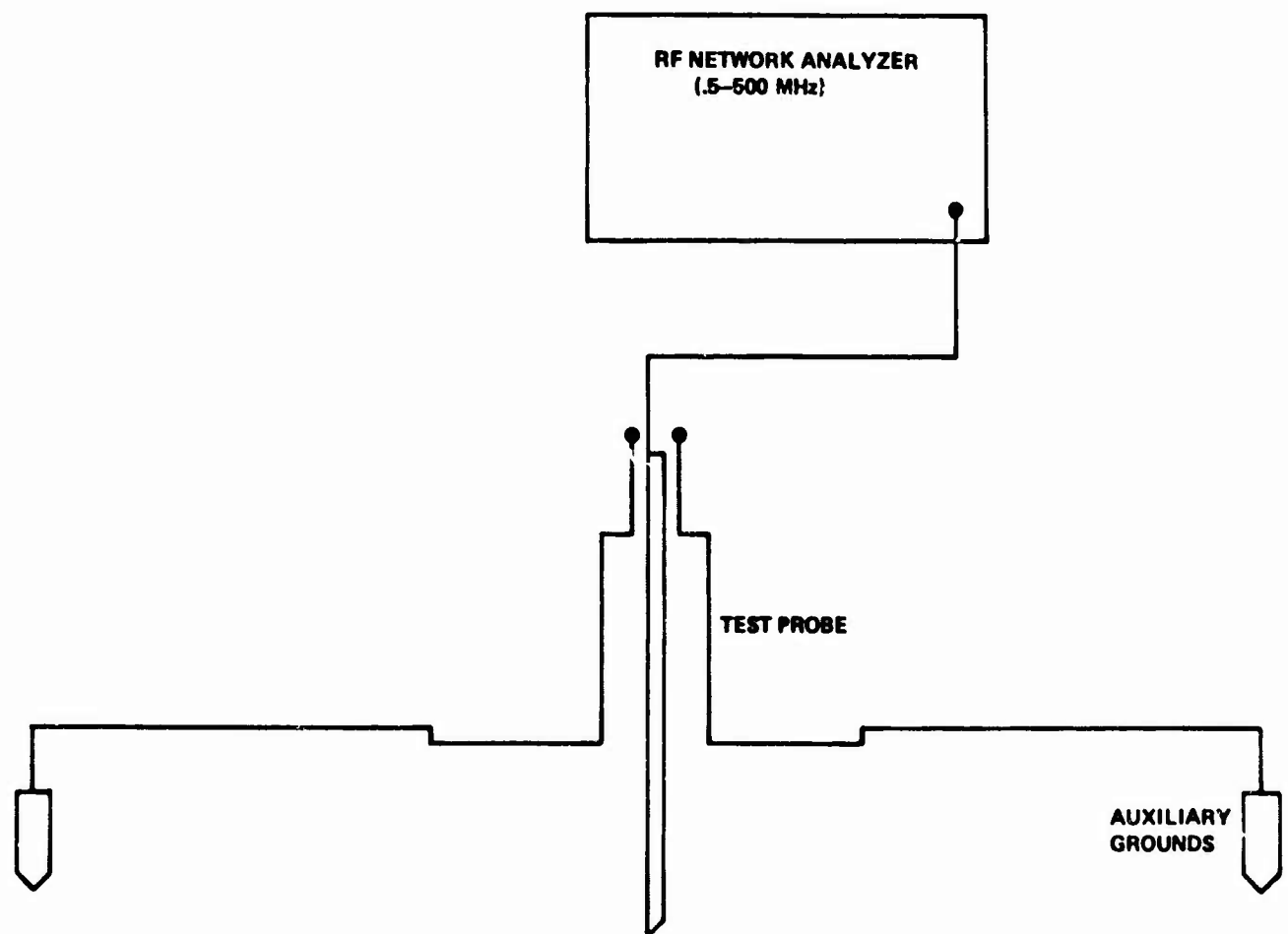

Fig. 7 - Test setup for high frequency measurements.

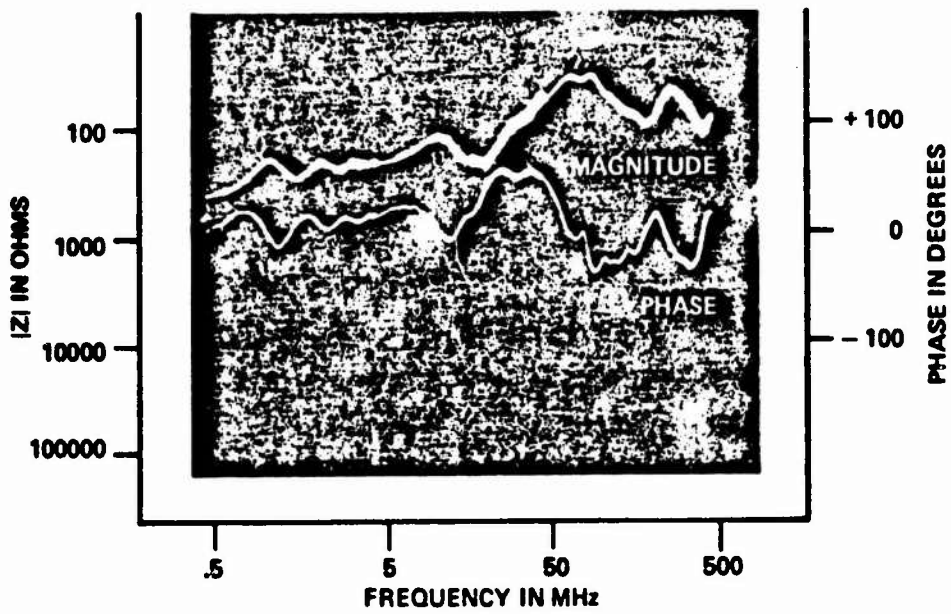

Fig. 8 - Impedance of ground rod and one auxiliary ground.

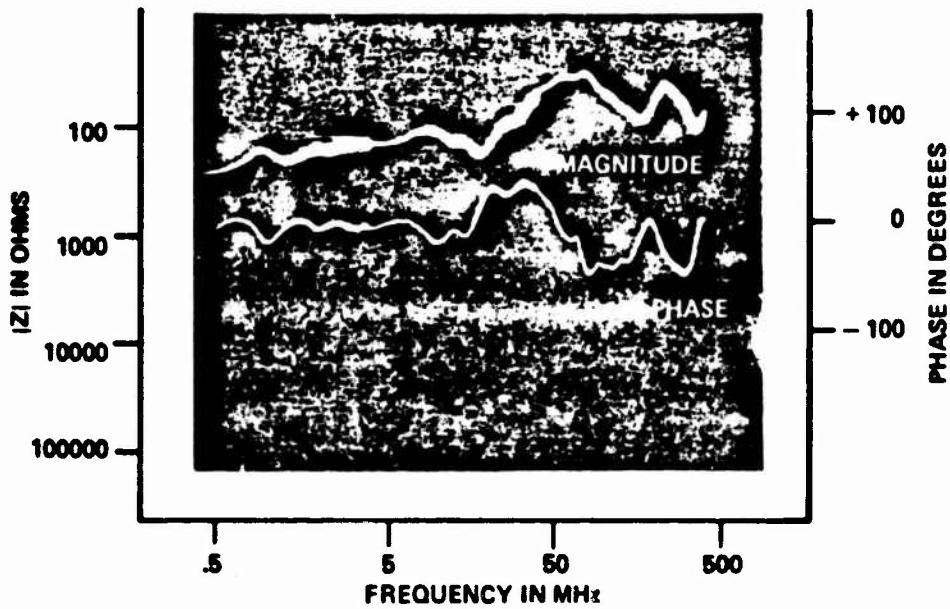

Fig. 9 - Impedance of ground rod and two auxiliary grounds.

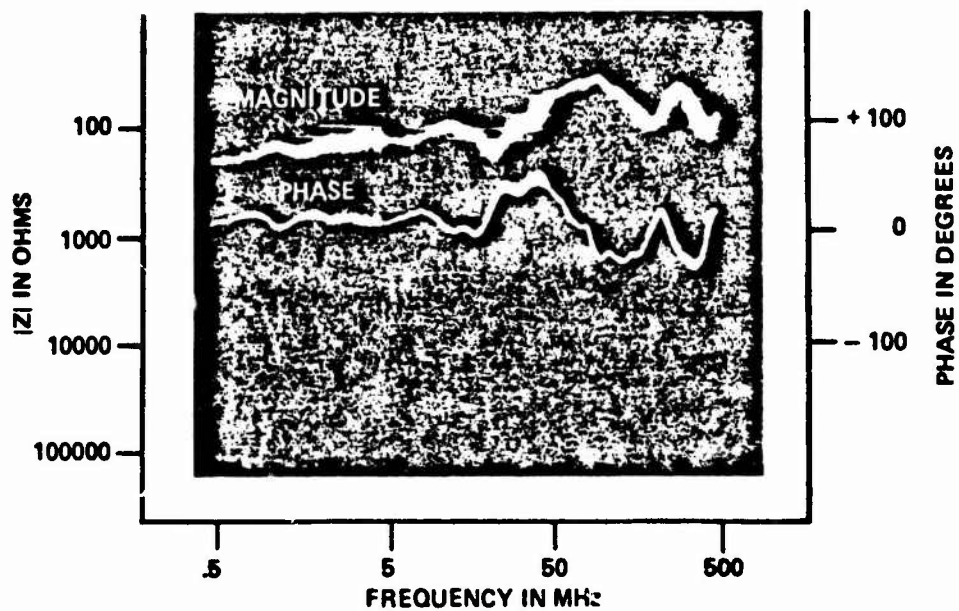

Fig. 10 - Impedance of ground rod and three auxiliary grounds.

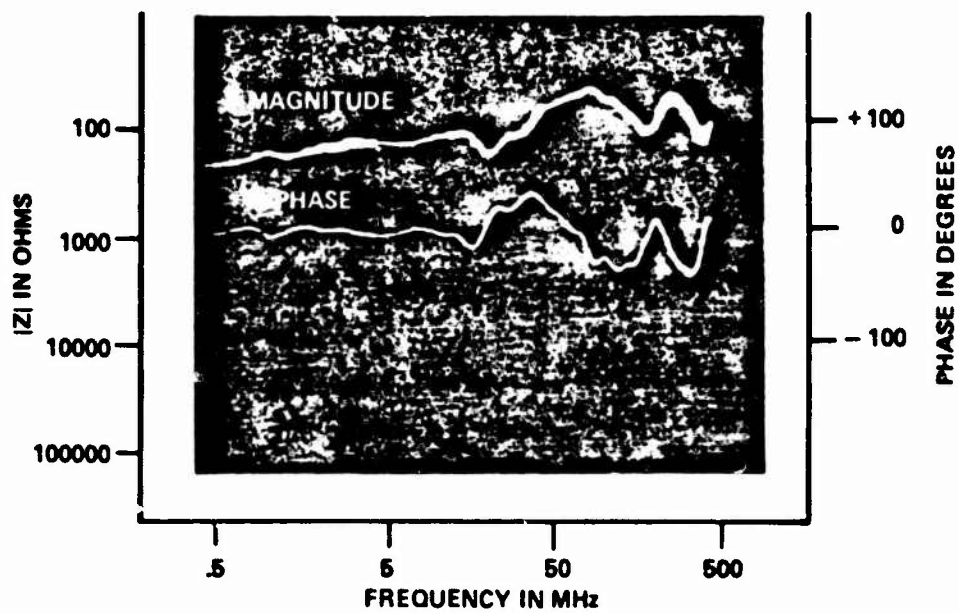

Fig. 11 - Impedance of ground rod and four auxiliary grounds.

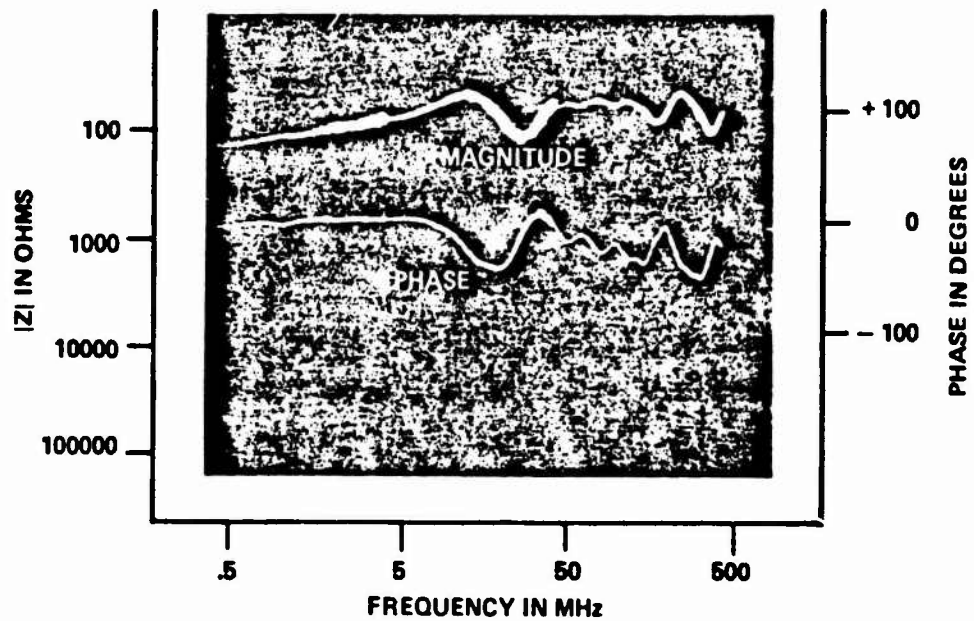

Fig. 12 - Impedance of ground rod, four auxiliary grounds, and an aluminum ground plate.

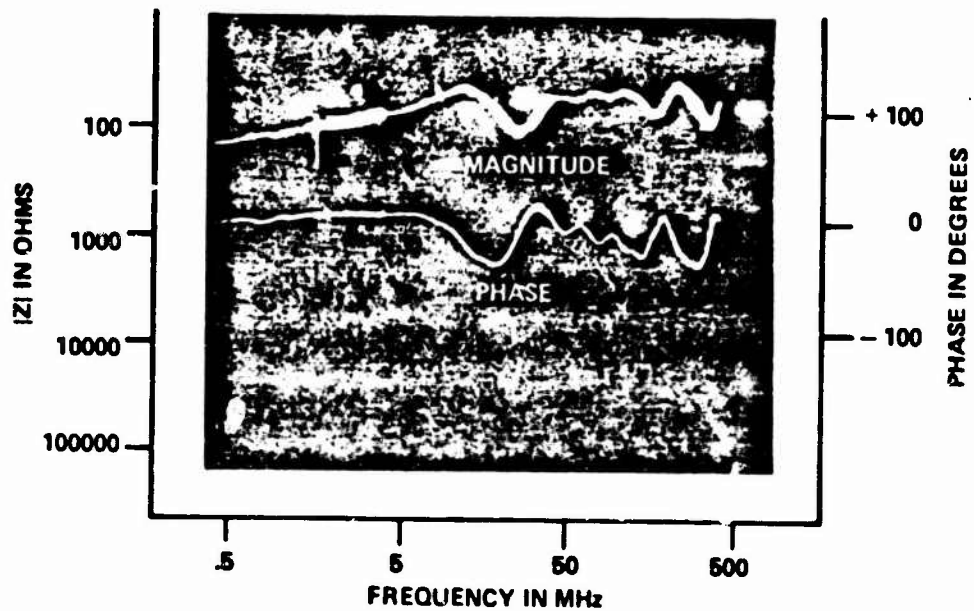

Fig. 13 - Impedance of ground rod, four auxiliary grounds, and a buried aluminum ground plate.

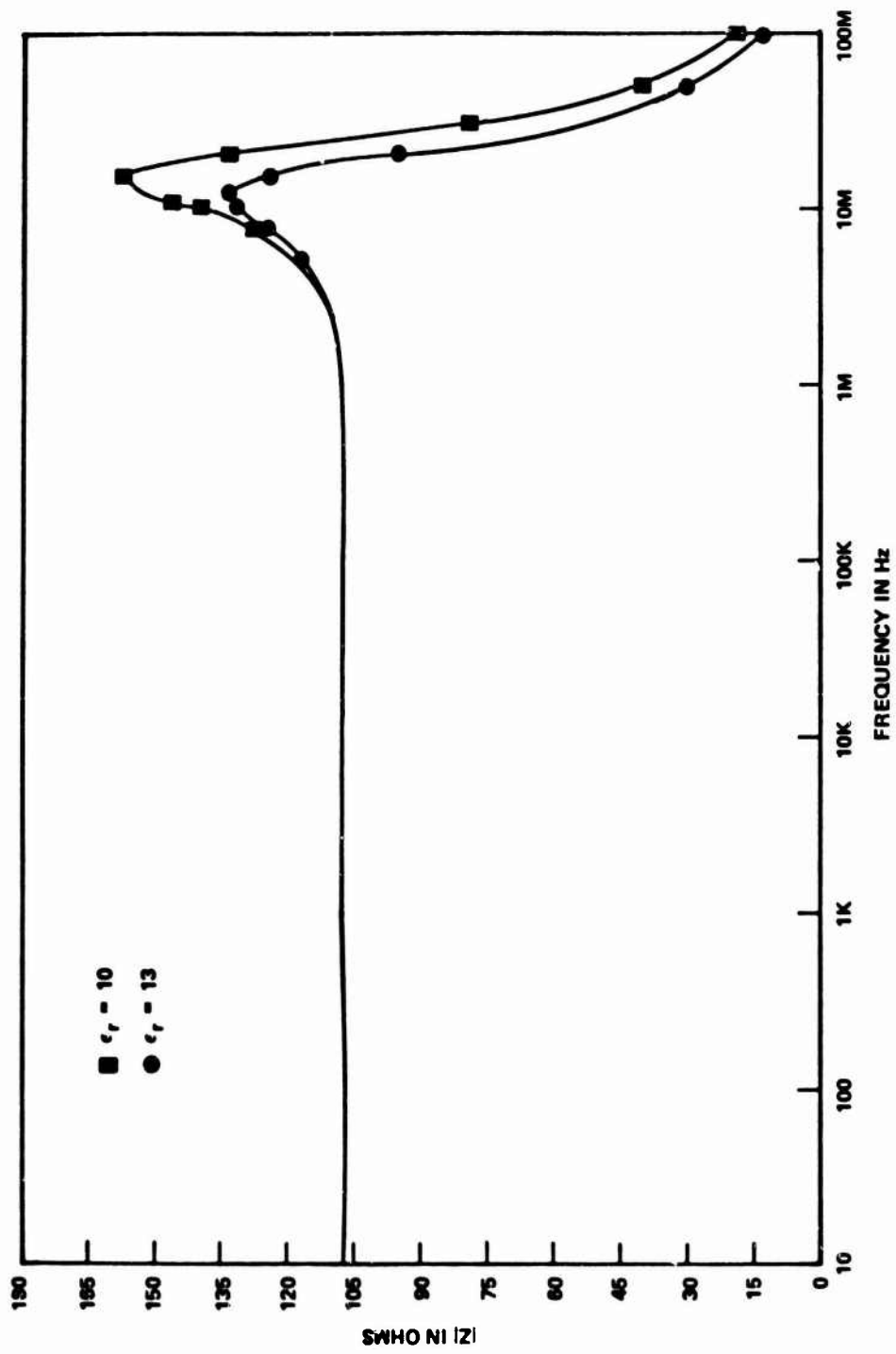

Fig. 14 - Computer simulation of impedance of ground electrode model.

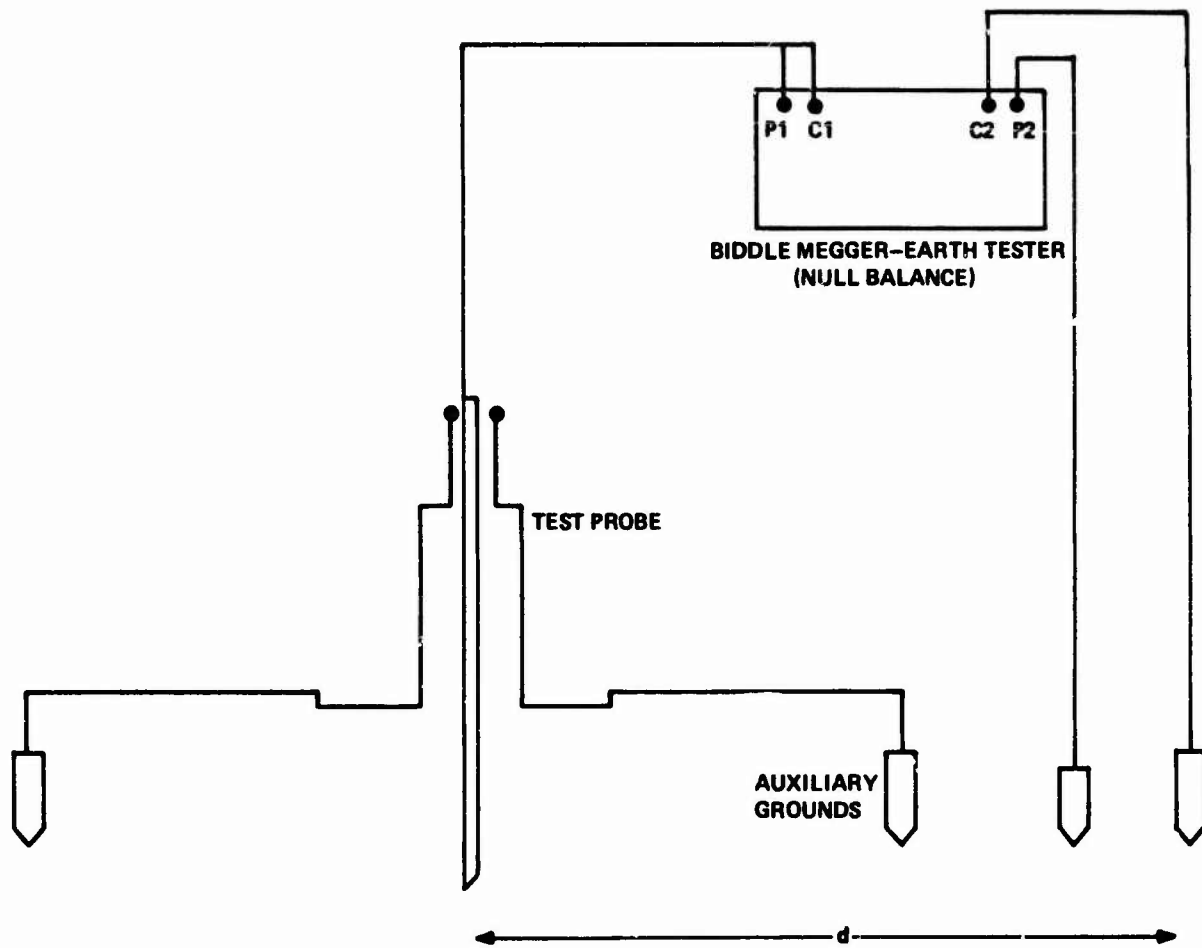

Fig. 15 - Test setup for low frequency measurements.

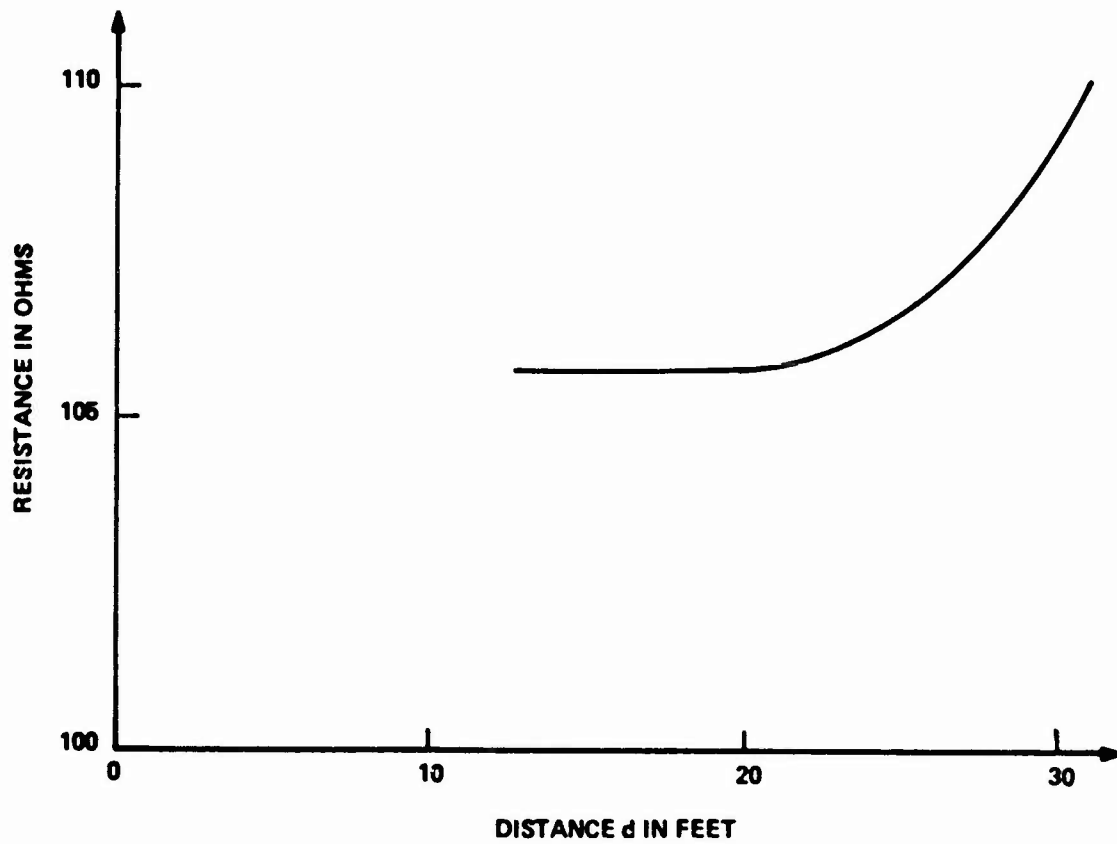

Fig. 16 - Test probe resistance characteristics.

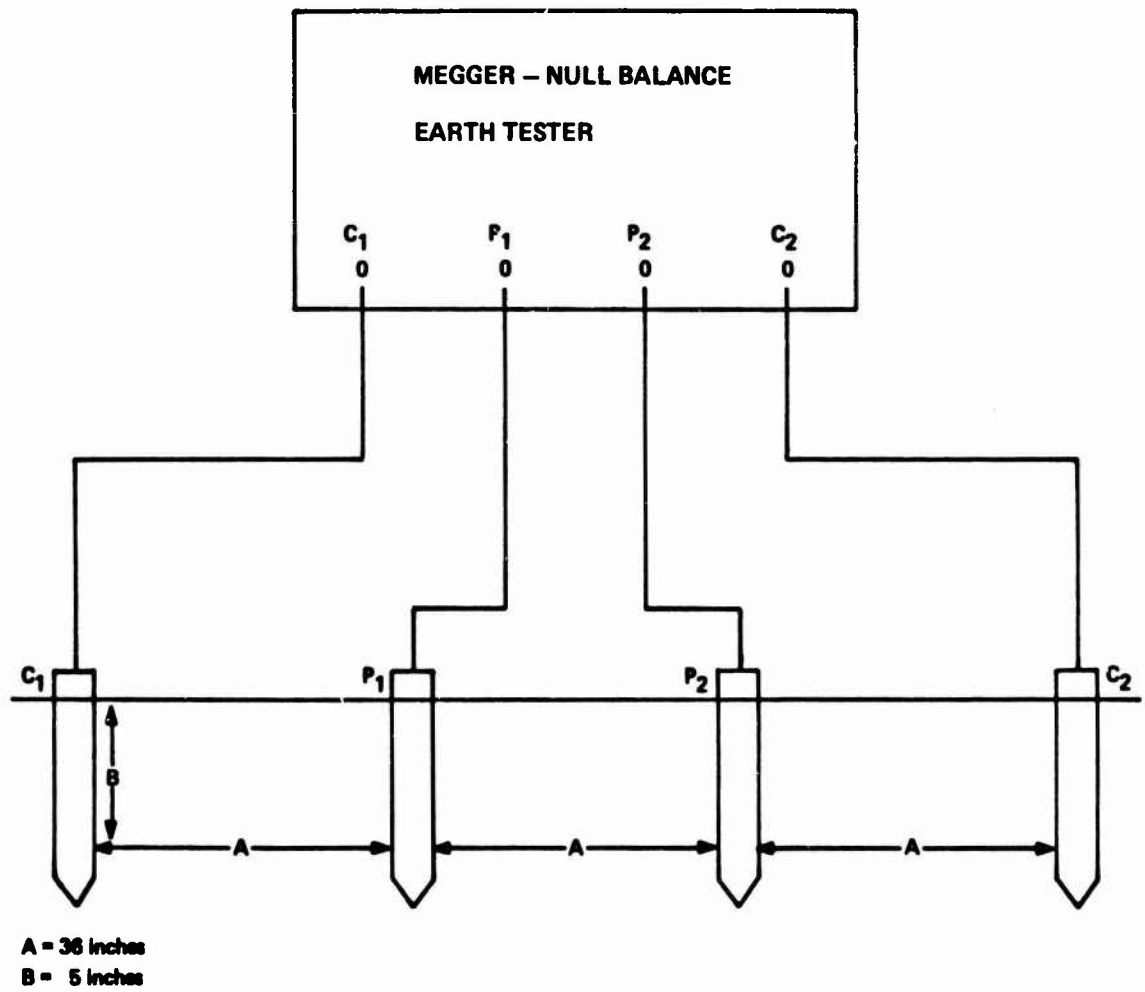

Fig. 17 - Soil resistivity measurement setup.

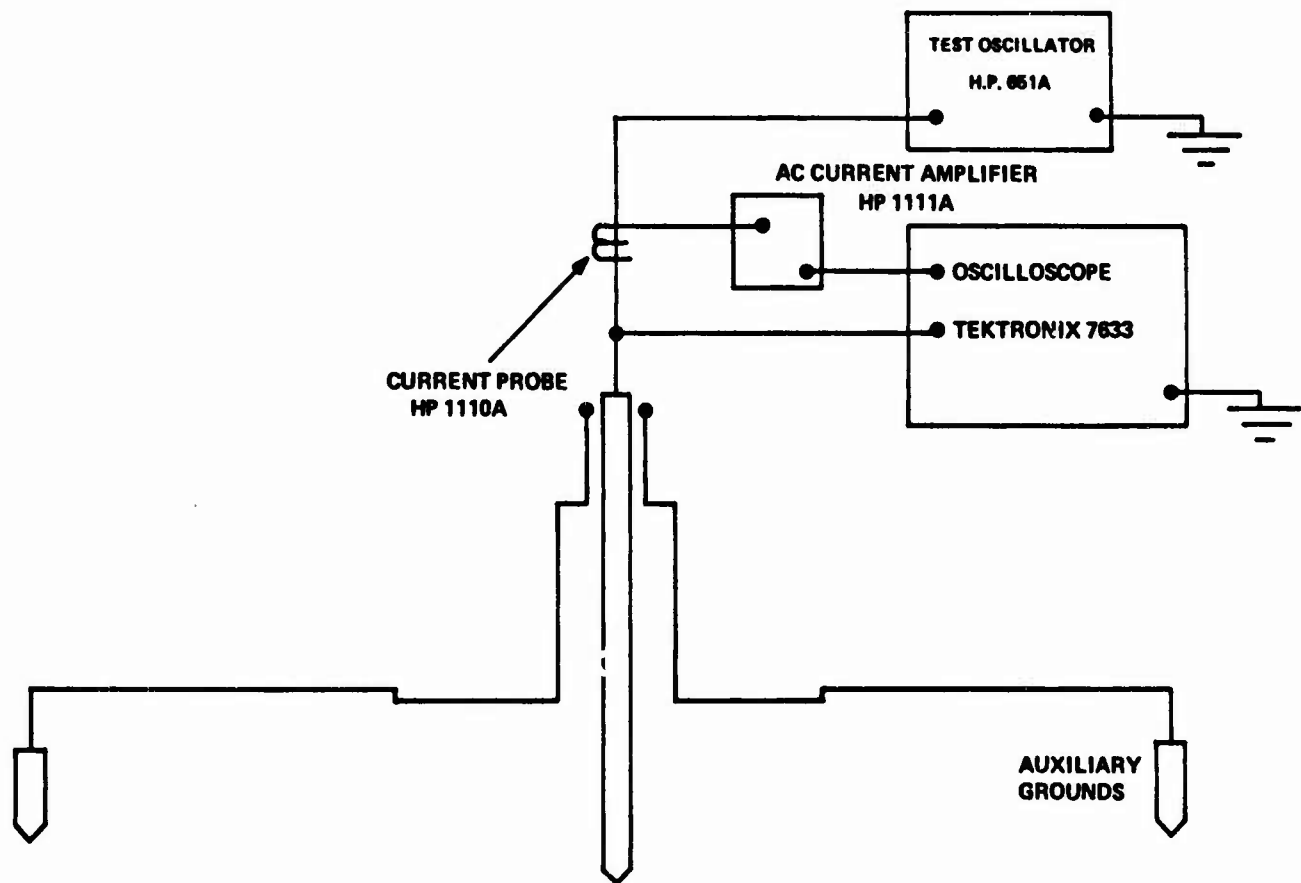

Fig. 18 - Test setup for mid-frequency measurements.

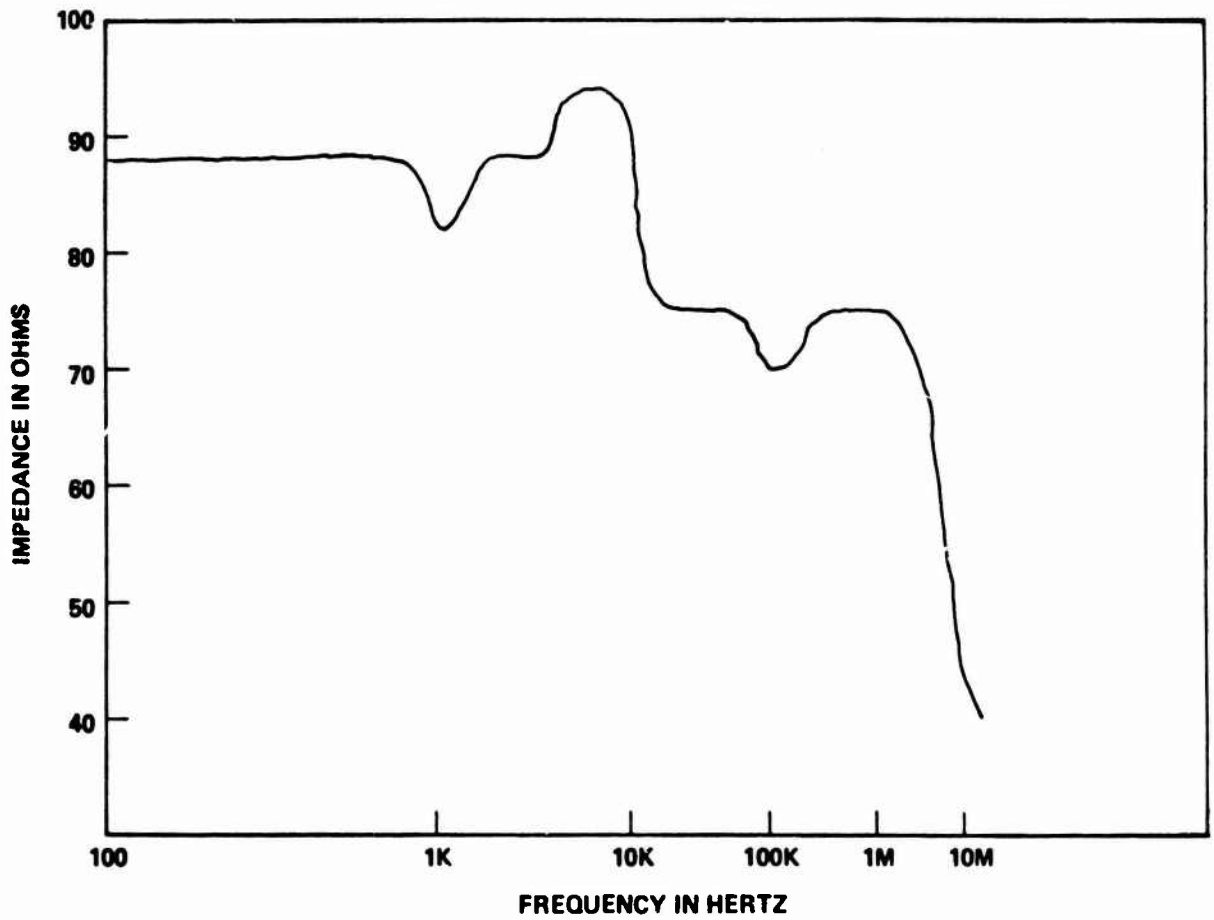

Fig. 19 - Mid-frequency ground electrode impedance behavior.