

AD P 002193

RECENT LIGHTNING INDUCED VOLTAGE TEST TECHNIQUE INVESTIGATIONS



Keith E. Crouch
Lightning Technologies, Incorporated, Pittsfield, Massachusetts

ABSTRACT

Lightning induced voltage testing has evolved over the past several years. Recent efforts into investigating the cause/effect relationships associated with technique procedures has generated a better understanding of test circuit behavior.

The aircraft under test must have a spaced set of return conductors around the aircraft to maintain a realistic electromagnetic field condition. The aircraft, the return conductors, and the facility where the tests are conducted form sets of short transmission lines. The travelling waves propagate in a transverse electromagnetic (TEM) mode at the speed of light. However, due to reflections and refractions at the junctions of different impedance sections of the aircraft (i.e., wing and tail attachments) the bulk of the wave energy travels distances considerably farther than the nose-to-tail dimension. Consequently, the wave appears to take longer to reach the tail, which had been interpreted as a slower propagation velocity.

Travelling electromagnetic waves reflecting and refracting on the aircraft transmission lines control the response of the system during the initial few microseconds of the test. For slowly rising test current waves, ($> 5 \mu\text{s}$) the transmission line characteristics of the test circuit can be ignored. At current risetimes of $1-5 \mu\text{s}$, the aircraft can be represented by a single impedance transmission line which can be terminated in a characteristic resistance. At very fast risetimes ($< 0.5 \mu\text{s}$) the aircraft system looks like a connected set of short transmission lines of different impedances. In the limit, the system itself will govern the current risetime which can be injected due to the reflection/refractions and the low pass filter characteristics of the system. With present configurations, current risetimes faster than 100ns do not appear possible.

= MICROSECS

BACKGROUND

More and more flight critical control functions are being performed by solid state electronic systems. The effects of adverse environments on the systems has been of concern. One of the more potentially damaging environments is generated by lightning strikes to the aircraft. In addition to using micro-circuitry, many new high performance aircraft utilize advanced composite structural materials which can increase the electromagnetic levels around the aircraft electrical wiring system.

These potential problems are not new and NASA sponsored efforts to understand and develop test techniques to measure lightning induced voltages were started almost 15 years ago. This work identified two areas of need, 1) an analytical technique which could be applied during the aircraft design phase to reveal potential problems and 2) a non-destructive test technique to verify that the aircraft met its design goals. Further work in the first areas has been carried out by a number of investigators from various organizations.

NASA sponsored work in the second area resulted in the Lightning Transient Analysis (LTA) test which has been applied to several aircraft systems. Work is still needed in both areas since the efforts to date have not resulted in techniques which are widely accepted. The work reported in this paper is in the second area.

Before exposing new aircraft systems containing advanced composite structural materials and solid state micro-circuit controls to in-flight lightning, it is desirable to have some assurances in the form of test data available to indicate that the systems will survive.

The original non-destructive test technique (LTA) was published in 1974(1)*. Measured induced voltages were extrapolated to full threat level using a ratio of the applied peak current to a selected threat level (30kA or 200kA). The applied current waveshapes were chosen to fit the average and severe current models generated by the Cianos and Pierce data. An average stroke of 30kA peak and 22kA/ μ s rate of current rise can be represented by a current pulse rising to crest in 1 μ s. A severe stroke of 200kA peak, 100kA/ μ s can be extrapolated from a current pulse with a 2 μ s crest time. Data obtained from these tests showed that the peak induced voltages, especially in single point ground circuits, occurred in the first 1/2 μ s, considerably before the crest of the applied current (usually at 2 μ s). This apparent lack of correlation between the stimulus and the response caused many to question the validity of the test.

To investigate the fundamental cause/effect relationships, NASA funded further efforts in technique evaluation. The results of those efforts are contained in NASA CR 3329, 1980 (2), and LT-82-132, 1982 (3). This paper summarizes part of the work covered in those reports.

TEST CIRCUIT RESPONSE

The LTA test technique does not stipulate the circuit return conductor configuration. Early tests were conducted using a single return wire, usually laid under the center line of the aircraft (4). As the effects due to return wires were recognized, the returns were split and routed around the perimeter of the aircraft (5). Later work indicated that the return wires should be distributed around the aircraft in a pattern which follows the electric field lines (6). All of these changes improved

*Numbers in parenthesis designate references at the end of the paper.

the electromagnetic field configuration around the aircraft and hopefully made it more representative of the inflight fields.

In flight, the lightning current has a return which is effectively at infinity. The aircraft also exhibits a surge impedance which is governed by the physical dimensions of the aircraft alone. When the aircraft is positioned in a hangar and surrounded by return conductors, the electromagnetic environment is greatly altered. Viewed at the current input point (attachment point), the test circuit looks like a short electrical transmission line, with a surge impedance of 75 to 150 ohms. Due to the close proximity of the return conductors, this surge impedance level is probably much lower than the corresponding inflight situation. But, from a practical standpoint, not much can be done about it. If the return conductors are moved away, two problems arise. The total circuit impedance goes up, reducing the applied current, and the aircraft must be raised off of the hangar floor. The second problem will establish limits long before the first has much effect.

Unfortunately, during the ground test more than one set of transmission lines affect the circuit response. The circuit return conductors will also set up effective transmission lines between themselves and other conductors in the near vicinity (rebar in the hangar floor, steel walls and roofs, electrical conduits and conductors in the area). All of these other conductors make up a building or facility ground

plane. Whenever a signal is introduced into the primary transmission line (between the aircraft and its return line) some response will be induced into the secondary transmission lines. As travelling waves propagate on these primary and secondary transmission lines, they interact with each other and both contribute to the final waveshapes observed in measurements taken in the primary system.

Tests conducted on both the F-8 and the relative geometric scale model verified the transmission line performance of the test circuit. To minimize the effects of waves propagating in the secondary transmission lines, resistors were connected between the return lines and building ground. The improvement in circuit behavior is shown in Fig. 1. These termination resistors do not prevent energy coupling into the secondary lines, but they absorb it to prevent reflections.

When the switch between the generator capacitor and the test circuit is closed, the capacitor voltage will be impressed across the circuit impedances. The voltage impressed across the primary transmission line will be a function of the transmission line surge impedance and the series impedance between the capacitor and the transmission line. At that time, voltage and current travelling waves will begin propagating down the transmission line. The voltage and current rates of rise will be a function of the switch operating time. In general, arcing switches are used and the risetimes are quite short. This means that a low magnitude current pulse (<10% of the final peak) but with a very fast rise time (<0.1 μ s) as shown in Fig. 2, could be inducing voltages in the electrical wiring. These voltages, due to the fast risetimes involved, could be an order of magnitude higher than the response to the 2 μ s risetime current. This phenomena could very definitely account for the observed discrepancy between applied current risetime and the induced voltage response.

In an attempt to resolve this problem, the test circuit was redesigned to have a resistor between the aircraft and the return lines equal to the approximate surge impedance of the system as shown in Fig. 3. This provides two changes; first, the transmission line is terminated and no reflections can occur. Secondly, the series inductor value is increased ($L/R = 2\mu$ s) since R increased, so the magnitude of the first current pulse is decreased. Although it may not completely eliminate the induced voltage response due to travelling waves, it will reduce it to at least the same magnitude as voltages caused by the applied current pulse.

TRAVELLING WAVE VELOCITIES

If the termination of the aircraft is removed and the aircraft isolated from the return lines, measurements of the travelling waves on the airframe can be made. When a transmission line is open circuited on one end and shorted on the other (source capacitor) the reflected waves will result in a damped oscillation with a frequency equal to four times the electrical transit time as shown in Fig. 4. Tests conducted on both the F-8 and the relative geometric scale model resulted in calculations predicting transit times corresponding to wave velocities less than the speed of light.

A test fixture was designed and tests specifically conducted to measure and understand the phenomena observed. Originally, it was theorized that the diameter of the center conductor in an array of wires (fuselage) could affect the wave propagation due to its reduced inductance per unit length. Measurements of transit times on the fixture (20 ft. long, 4 ft. dia.), shown in Figs. 5 and 6, were made using a two wire system and a nine wire system (8 return wires and a center tube). The results of the tests, shown in Fig. 7 and Table I, revealed that transit times corresponded to the speed of light within the accuracy of the measurements.

Table I - Summary of Transit Times Determined From Open Circuit Ringing Frequencies

Test No.	Description	Frequency MHz	Transit Times ns
69	Two Wire	10.3	24.2
80	8 Wires & Center Wire	10.8	23.2
105	12.5cm & 8 Wires	10.8	23.2
-	6.15m	calc. from speed of light	20.5
-	6.9m	speed of light	23.0

To evaluate the response further, aluminum foil wings and a vertical fin were added to the fixture in the same proportion as the F-8 dimensions as shown in Fig. 8. As each of the three items were added, the oscillation frequency decreased as shown in Fig. 9. The final tests showed a frequency reduction of 45%, very close to the 50% values observed during the F-8 tests. A set of measurements were made of the time of arrival of the voltage and current wavefronts. These measurements are shown in Fig. 10 and indicate that the waves are indeed travelling at the speed of light.

The aircraft is not a constant impedance transmission line. For fast rising pulses, it probably looks more like a series of several short transmission lines of different impedance. When the generator switch is closed, the travelling waves start down the pitot boom. At the junction between the boom and the forward fuselage, the impedance drops slightly. At the junction of the wings and the fuselage, a more significant impedance change occurs. The travelling waves reflect and refract at each of these junctions. The bulk of the wave energy travels down the fuselage, out of the wings, back to the fuselage, up the vertical fin and back to the tail. The total distance travelled is much longer than the length of the aircraft and the period of oscillation will be related to this length. Observations of the oscillograms in Fig. 10 does show evidence of reflections that could be associated with the wing attachment point.

FAST RISING CURRENT TESTS

Cianos and Pierce (7) provides data to substantiate the use of a $2 \times 50\mu\text{s}$ waveshape for lightning strokes reaching the ground. Recent data has been provided by other researchers who report current risetimes of considerably shorter durations. Risetimes of 25 to 50ns have been observed using the indirect measurement technique (8,9). To generate current pulses with risetimes of these magnitudes, generators with different characteristics are required. An LC ladder network (LCLN) generator was designed to represent a portion of the lightning stroke channel and has a source surge impedance nominally equal to the aircraft test surge impedance. The generator is shown schematically in Fig. 11.

Tests conducted with this generator, which has 24 stages, resulted in current pulses with risetimes of 100 to 125ns. At high voltages, 20-50kV, considerable variation in the applied voltage waveshape was noted from pulse to pulse as shown in Fig. 12. Since the generator was configured to operate on a repetitive pulse basis of 5-20 pulses per second, variations in succeeding pulses were quite obvious in the oscillograms taken of the applied voltage and current. Tests showed that the variations appeared to be related to switch breakdown characteristics. A standard high voltage triggered sparkgap was used for this work. After triggering, the rate at which the gap switches will be a function of several variables, including spacing, voltage, air density, presence of free electrons, etc. Consequently, the closing time will be a statistical distribution about some nominal value. If that time is on the same order of magnitude as the required risetime of the current pulse, then variations will result. A study of the oscillograms show that the switch is closing faster than the risetime but not at uniform rates. Using lower voltages and a mer-

cury wetted relay switch resulted in perfectly repeatable applied waves. However, the waveshapes are somewhat different. Comparisons are shown in Figs. 13 and 14.

The most important point observed was the inability to inject current pulses with risetimes faster than $\sim 100\text{ns}$. It is known that a mercury wetted switch will apply risetimes well below 1ns. It appears that the varying input surge impedance characteristics of the airframe must be controlling the shape of the applied wave. As faster and faster risetimes are applied, reflections and refractions from aircraft structural shape changes become more pronounced. The boom to nose cone junction and the front wheel reflections must be involved in the observed waveshape. Depending on the magnitude changes involved in the surge impedances, magnitude changes of 20-50% in the applied wave will result from these reflections. Such changes will distort the wavefront and make the definition of the applied wave risetime very difficult to interpret. Secondly, and just as important, is the fact that shape of the applied current at the injection point will bear little resemblance to the wave further back along the fuselage where the wires being tested may be located. If the wave risetime has slowed to 100ns by the time it reaches the midpoint of the aircraft after starting at 20ns, what is the rate of rise of the test? The majority of the cable runs are not at the nose but further back along the fuselage. A transmission line will act as a low pass filter for fast rising injected pulses, so the rate of rise will always decrease along the length of the line.

INDUCED VOLTAGE RESPONSE TO FAST RISING PULSES

During the F-8 test technique evaluations, induced voltage measurements were taken on a pair of flight control cable wires. The wires were connected to airframe at the base of the vertical fin and measurements were made at the pallet area just aft of the cockpit. Voltages in these wires were monitored throughout the test program using a battery powered Tektronix 475 oscilloscope installed inside the aircraft.

Measurements were made as the injected current waveshape was changed. With a $2 \times 50\mu\text{s}$ waveshape applied, as shown in Figure 15, two identifiable frequencies are observed in the induced voltage oscillograms; one at 750-800kHz and a low level oscillation at 10-11MHz. Using the LCLN generator, a 120ns risetime pulse was applied. The resulting induced voltage, shown in Fig. 16, now contains a significant contribution at 10.6MHz. Modifying the LCLN generator (removing inductors) yielded a risetime of 90ns. Induced voltage measurements made with this applied pulse, shown in Fig. 17, resulted in voltages very similar to the 120ns pulse except that the 10.6MHz amplitude increased significantly.

A final test was conducted using a 0.1 μ F capacitor at 1177 dc and a mercury switch. The applied current pulse was found to be double humped. The first portion raised in about 50ns. In attempting to increase the current rate of rise some changes were made in the return circuit connections. The induced voltage shown in Fig. 18 now has a predominate response 11.8MHz with low level oscillations of 40-80MHz present.

To investigate the response of the flight control wires, they were excited by pulsing them at the base of the vertical fin using the 0.1 μ F capacitor and the mercury relay. Except for some steps at 100ns on the front, the response shown in Fig. 19 was approximately 2.5MHz. None of these frequencies or times correspond to the responses obtained during the induced voltage tests. Therefore, it can be concluded that the cables are not excited and/or oscillating during the induced voltage test, so they must be responding to electromagnetic fields inside the airframe. These fields are related to the aircraft external environment. It had been postulated that the aircraft dimensions would limit the upper frequency. This does not appear to be correct.

CONCLUSIONS

Significant developments in the LTA test technique have evolved in the past few years. More representative electromagnetic environments can be simulated due to the use of spaced multiple return conductors around the aircraft. A better understanding of the interaction of the return conductors and the facility grounds allows steps to be taken to reduce the problems in that area.

Perhaps the most significant achievement in understanding the test has been the identification of the role played by travelling electromagnetic waves. The aircraft and its return conductors represent an interconnected set of differing impedance transmission lines. The response of these transmission lines to the applied stimulus governs the tests that can be applied successfully as well as the induced voltage responses that occur.

Specifically, the transmission line travelling wave theories have resulted in the following conclusions:

- Travelling waves do propagate at the speed of light but travel distances further than the nose-to-tail dimensions.
- The airframe appears to behave like a collection of short, different impedance transmission lines. The induced voltage frequency content will reflect these frequencies rather than a frequency related to the major aircraft dimension.
- The airframe geometry will limit the practical risetime of the applied current pulse.

- The LCLN type of generator will provide the fastest input current pulse which appears to be on the order of 100ns.

However, in light of presently available data, most lightning induced voltage tests should be conducted using a 2 x 50 μ s test current which can successfully be generated using the resistively terminated return circuit configuration.

REFERENCES

1. L.C. Walko, "A Test Technique for Measuring Lightning-Induced Voltages on Aircraft Electrical Circuits", NASA CR-2348, 1974.
2. J.A. Plumer, and K.E. Crouch, "Improved Test Methods for Determining Lightning-Induced Voltages in Aircraft". NASA CR-3329, 1980.
3. K.E. Crouch, "Aircraft Lightning-Induced Voltage Test Technique Developments", Lightning Technologies, Inc. Report No. LT-82-132, 1982.
4. J.A. Plumer, F.A. Fisher and L.C. Walko, "Lightning Effects on the NASA F-8 Digital Fly-by-Wire Airplane". NASA CR-2524, 1975.
5. J.A. Plumer, "YF-16 #1 Lightning Transient Analysis Test Report". General Dynamics Report 16PR051, 1975.
6. P.F. Little, A.W. Hanson, and B.J.C Burrows, "Tests Techniques for Simulating Lightning Strikes to Carbon (Graphite) Fibre Composite Structures". Proceedings of the 1979 Federal Aviation Administration-Florida Institute of Technology Workshop of Grounding and Lightning Technology.
7. N. Cianos and E.T. Pierce, "A Ground-Lightning Environment for Engineering Usage", Stanford Research Institute, SRI Project 1834, 1972.
8. M.A. Uman, et al., "Calculations of Lightning Return Stroke Electric and Magnetic Fields Above Ground". Lightning Technology, NASA Conference Publication 2128, FAA-RD-80-30, April 1980. p.21.
9. C.E. Baum, et al., "Measurement of Electromagnetic Properties of Lightning With 10 Nano-second Resolution", Lightning Technology, NASA Conference Publication 2128, FAA-RD-80-30, April 1980. p. 39.

ACKNOWLEDGEMENTS

The author would like to acknowledge the support and encouragement of Calvin R. Jarvis and Wilton Lock of NASA Ames Research Center, Dryden Flight Research Facility. Work on the Digital Fly-by-Wire F-8 Aircraft has been instrumental in the developments reported here.

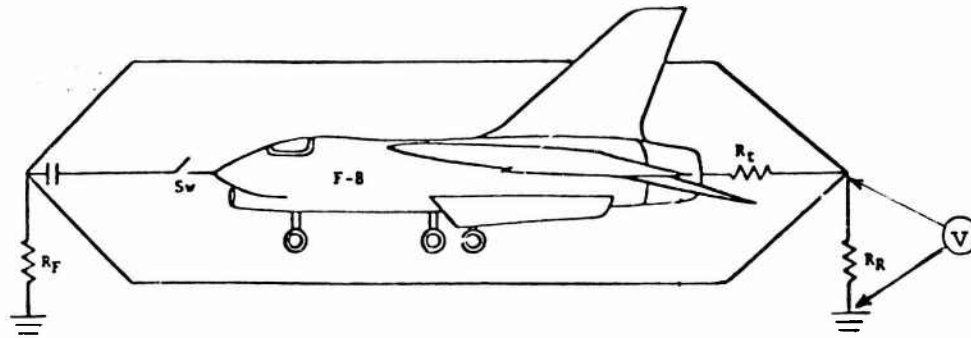

R_F (Ω)	Model	R_R (Ω)
-----------------------	-------	-----------------------

0		∞
---	--	----------

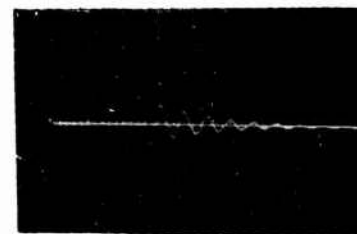

20 V 306 0.1 μ s

117		117
-----	--	-----

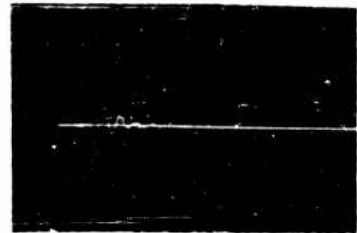

20 V 310 0.1 μ s

Full Scale

0		∞
---	--	----------

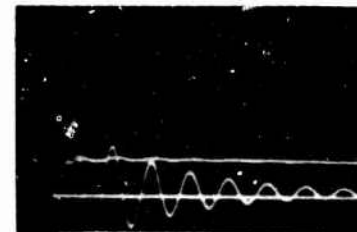

2.5 V 136 1.0 μ s

144		132
-----	--	-----

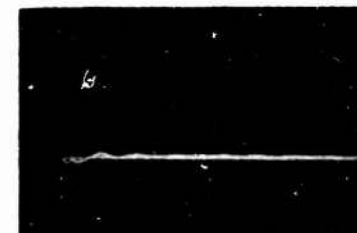

2.5 V 141 1.0 μ s

Fig. 1 - Typical return line-to-building voltages before and after termination

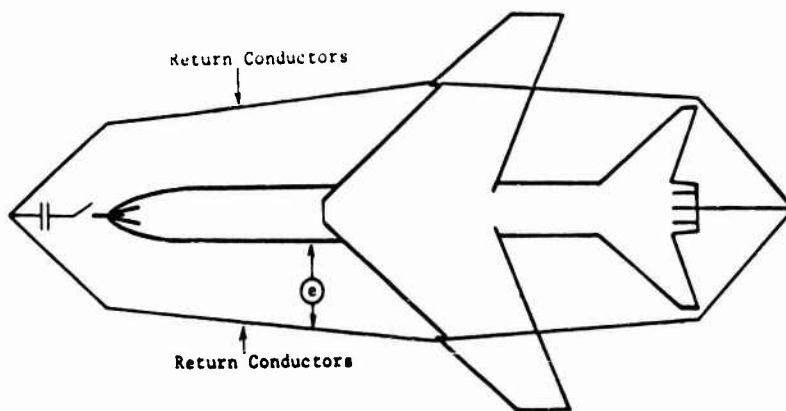

Idealized Test Circuit

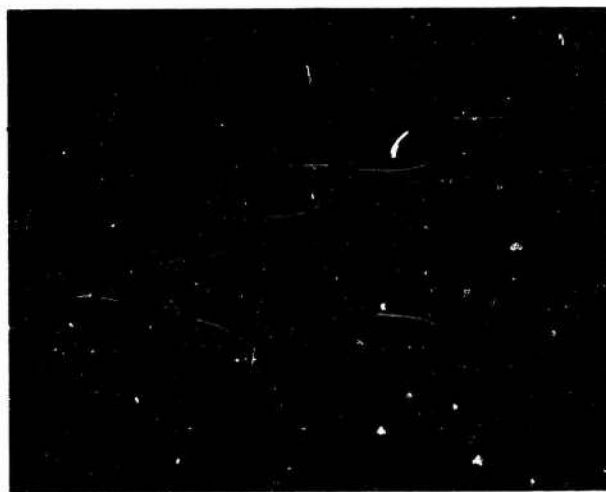

Voltage

Current

Figure 2 - Voltage and Current Travelling Waves on an Idealized Test Circuit; as Observed at the Center of the Fuselage.

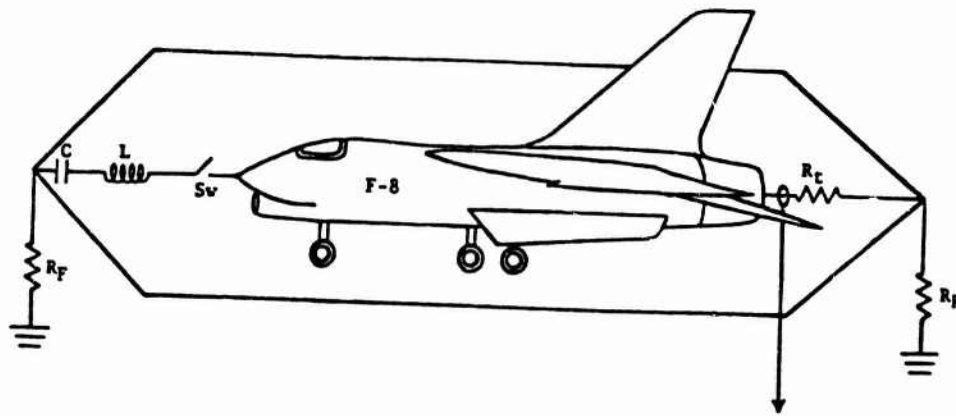

Model

1.08 A -

L = 7.1 μ H
 C = 0.04 μ F
 R_t = 100 Ω
 E = ~ 110 V



0.2 A 14A 0.1 μ s

Full
Scale

198 A -

L = 90 μ H
 C = 0.5 μ F
 R_t = 124 Ω
 E = 25 kV

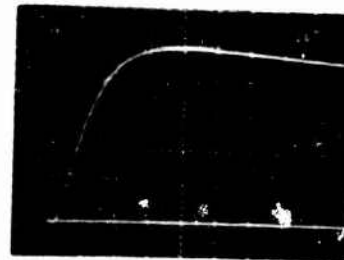

40A 680 1.0 μ s

Fig. 3 - 2 x 50 μ s Return Stroke into Aircraft Terminated with $R_t = Z_o$

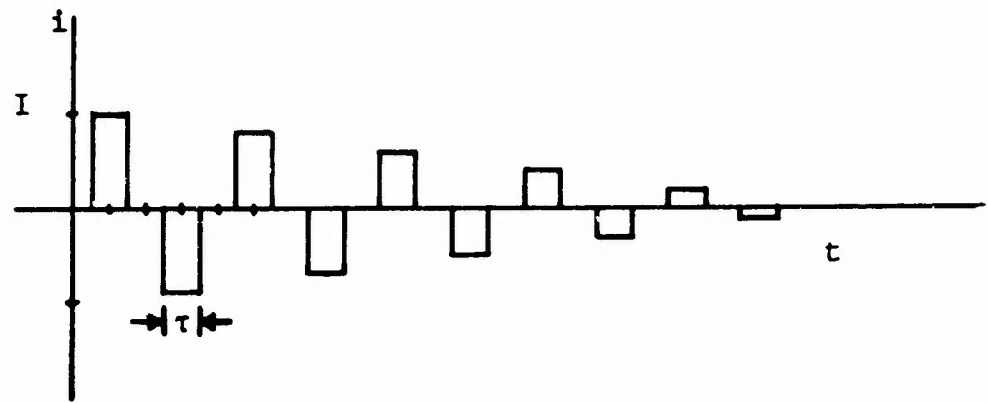
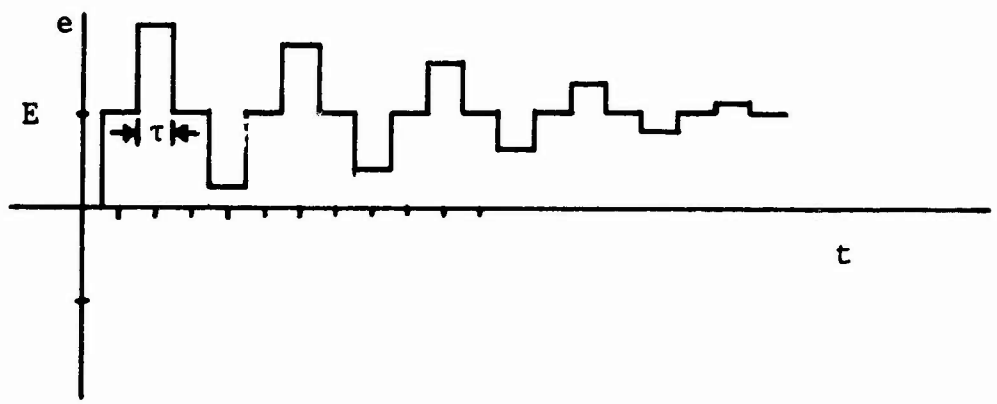
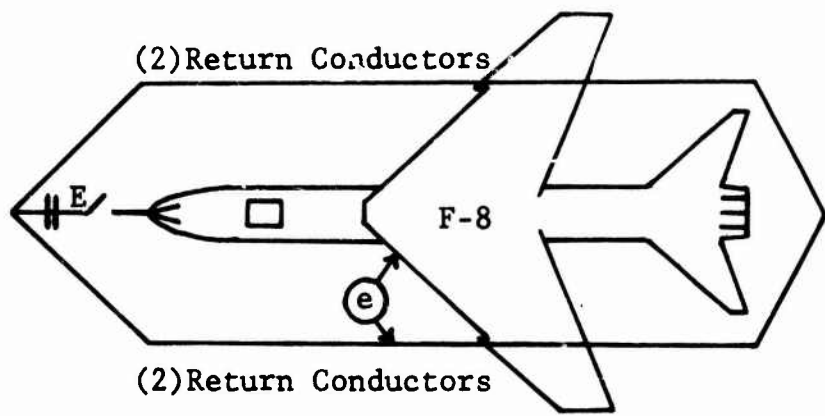

Fig. 4 - Voltage and current traveling waves on an idealized test circuit; as observed at the center of the fuselage

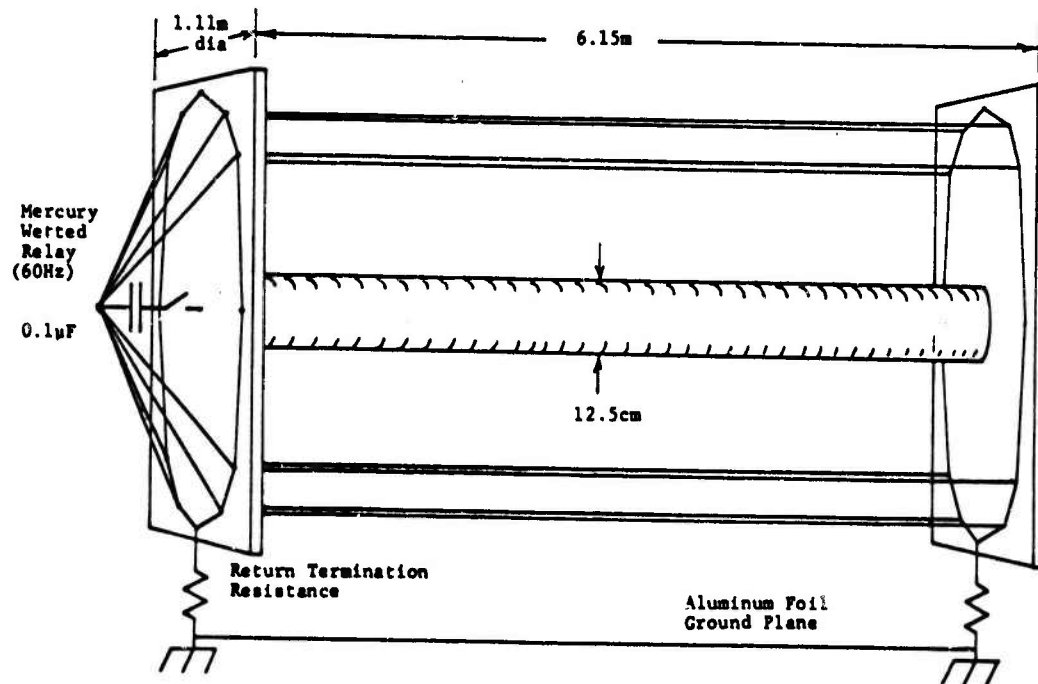

Fig. 5 - Diagram of transit time test fixture

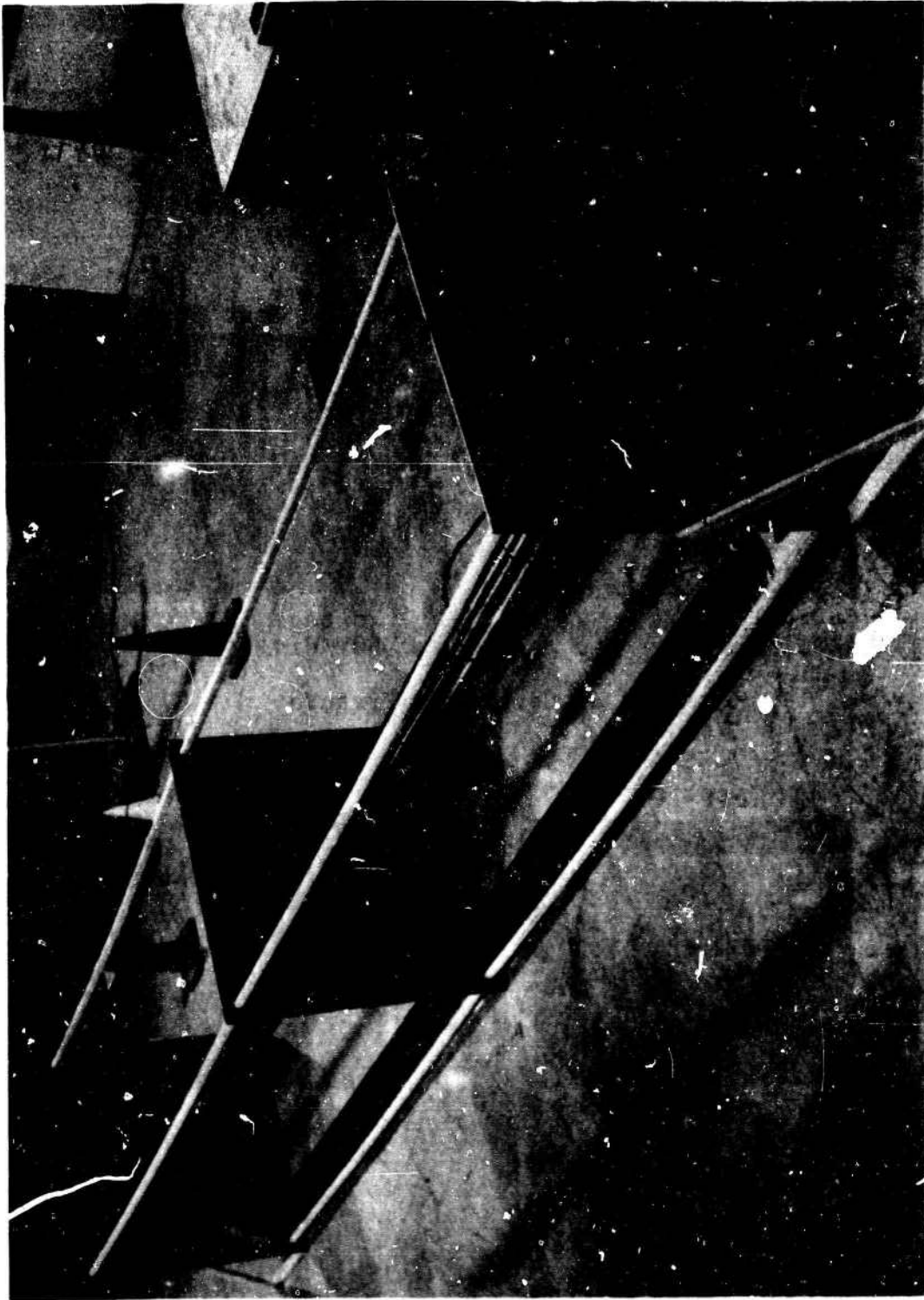
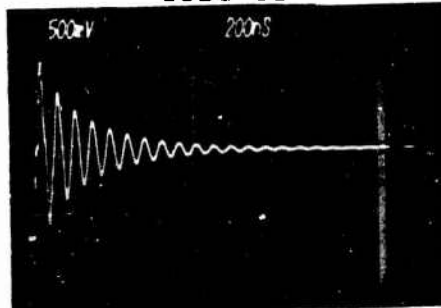

Figure 6 - Transit Time Test Arrangement

Test 68



Voltage
50V/div

Test 69

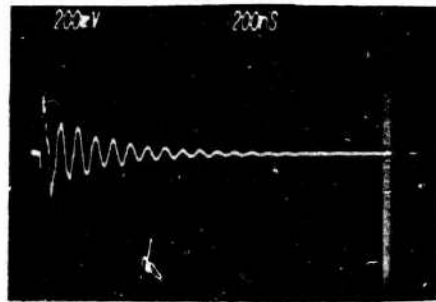

Current
4A/div

Measured at Center of Fixture

Test 79

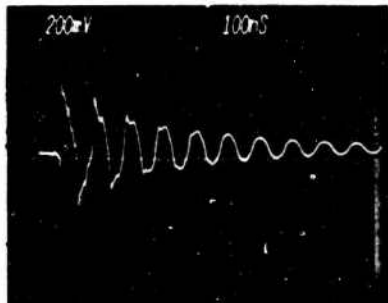

Current
4A/div

Test 80

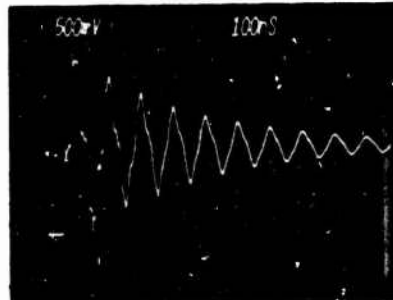

Voltage
50V/div

Measured at Center of Fixture

Test 101



Voltage
50V/div

Measured at
Center of
Fixture

Test 105

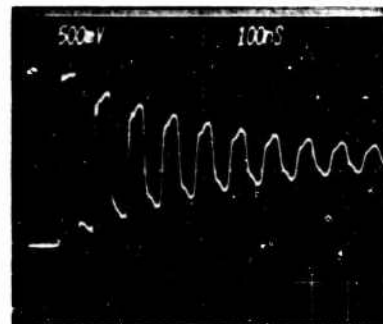

Voltage
50V/div

Measured at
the Far End
of Fixture

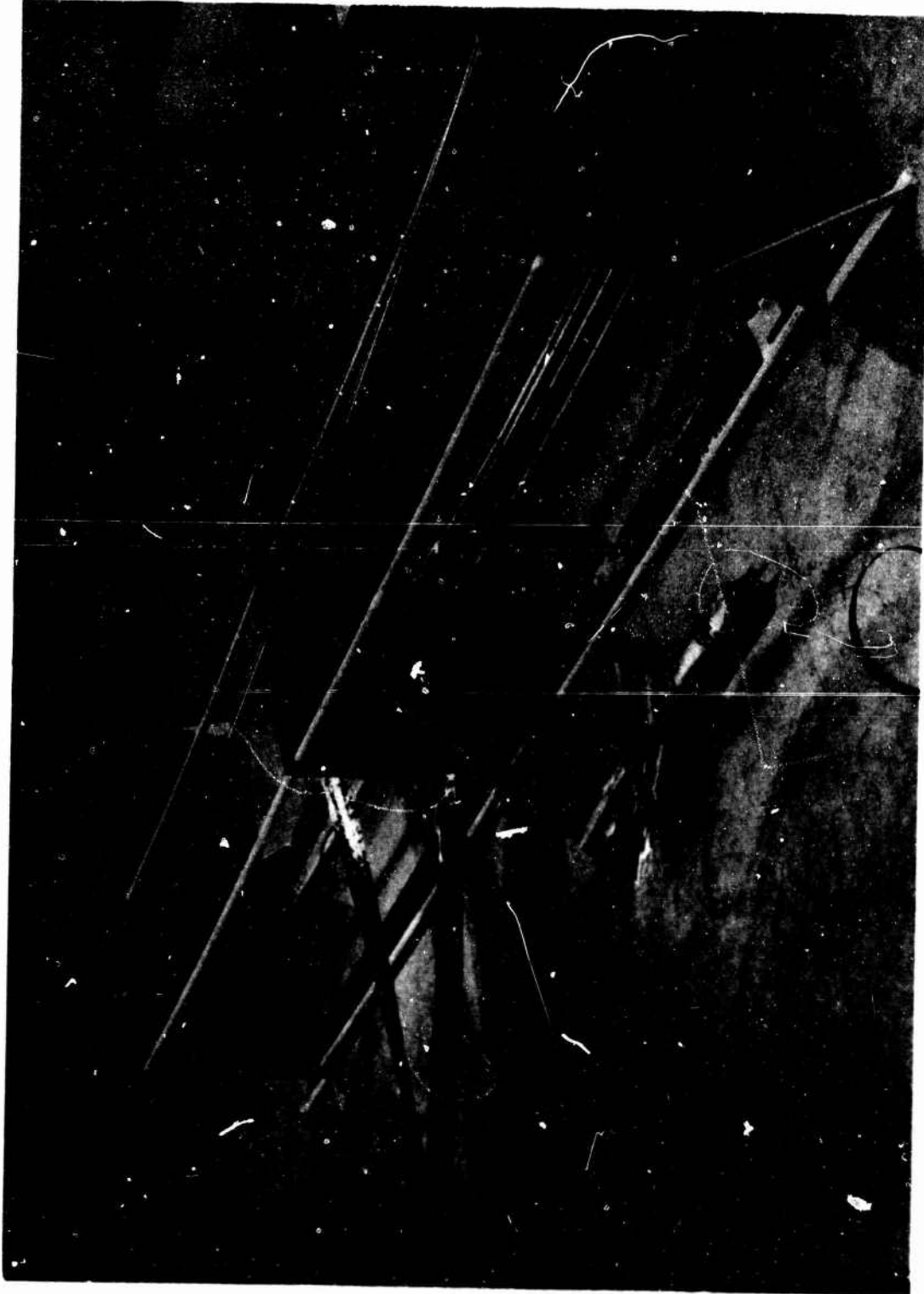
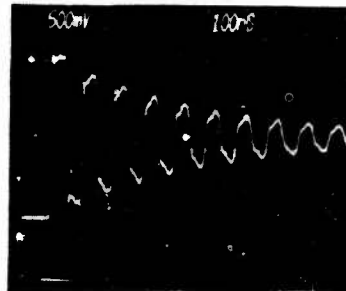

Figure 8 - Transit Time Test Fixture With Simulated Aircraft Wings & Tail

Tube & Returns
 $t = 23.3 \text{ ns}$

Test 105



50V/div 100ns/div
 Test 104

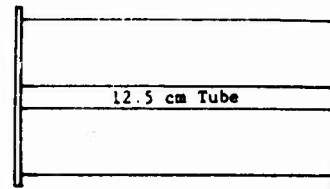

Add 1 Wing
 $t = 27.9 \text{ ns}$

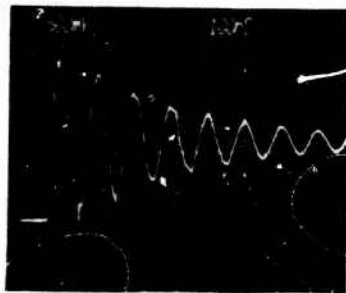

50V/div 100ns/div
 Test 106

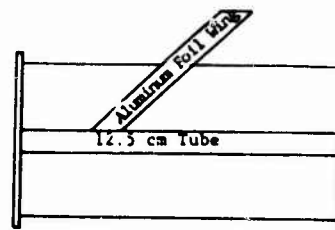

Add 2nd Wing
 $t = 31.9 \text{ ns}$

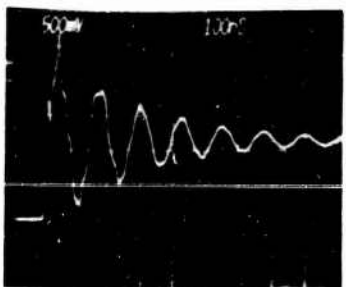

50V/div 100ns/div
 Test 108

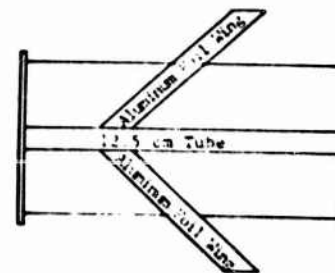

Add Tail
 $t = 32.8 \text{ ns}$

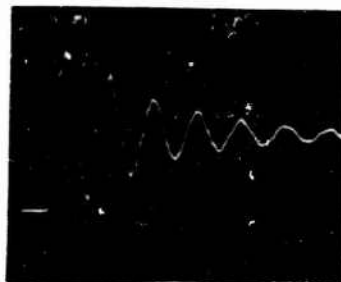

50V/div 100ns/div

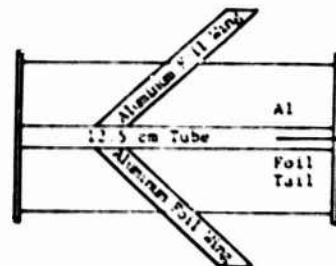

Note: All measurements at Rear of Fixture

Figure 9 - Comparison of Ringing Frequencies as a Function of Added Parts

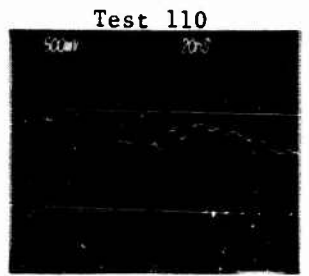

Voltage 20ns/div
50V/div

Front of the
Test Fixture

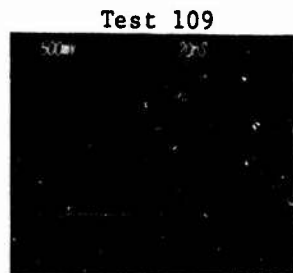

Voltage 20ns/div
50V/div

Rear of the
Test Fixture

Fig. 10 - Comparison of Travelling Wave Voltages at the Front and Rear of the Fixture With Simulated Wings

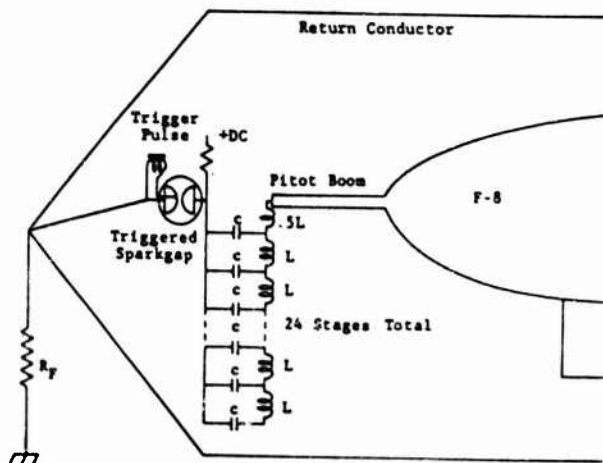
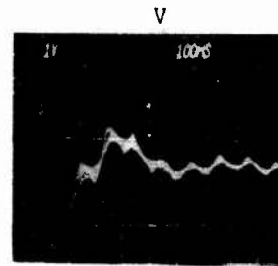

Fig. 11 - Schematic Diagram of the LCLN Repetitive Pulse Generator Configuration

Test 216



4900V/div 100ns/div

I

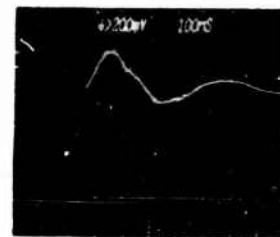

>200A/div 100ns/div

Fig. 12 - Fast Rise Voltage and Current Oscillograms at the F-8 Pitot Boom

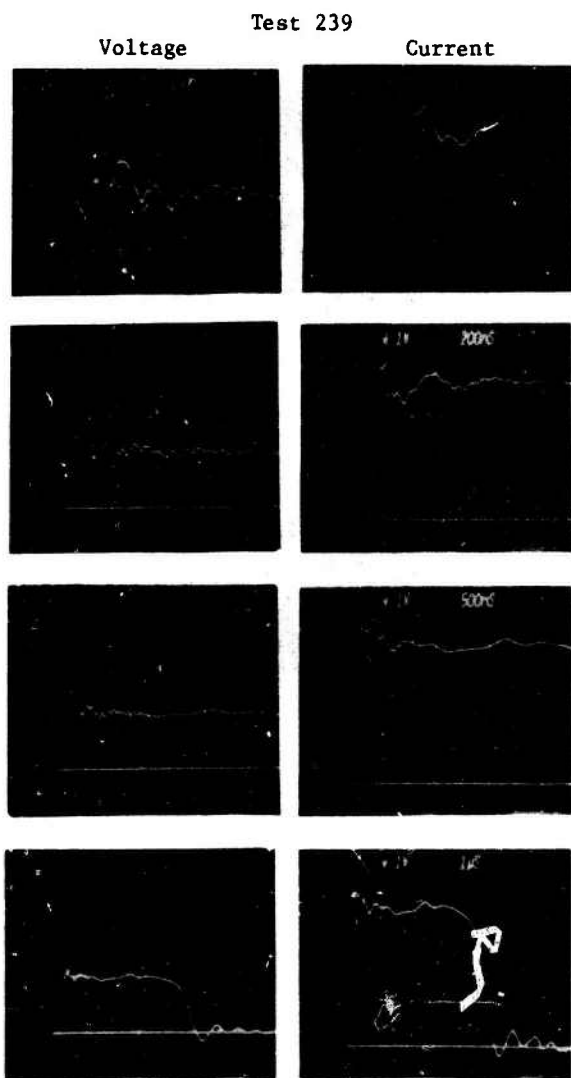

Note: Voltage Oscillograms are 5190V/div
 Current Oscillograms are 20A/div

Fig. 13 - High Voltage Triggered Sparkgap
 Switch LCLN Generator Oscillograms

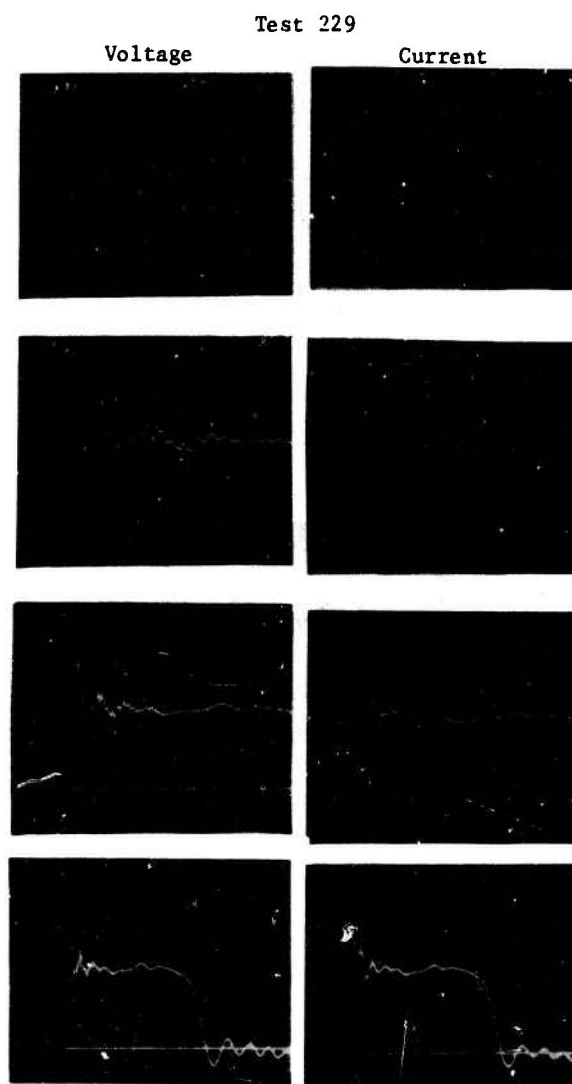

Note: Voltage Oscillograms are 22.5V/div
 Current Oscillograms are 0.2A/div

Fig. 14 - Low Voltage Mercury-Wetted Switch
 LCLN Generator Oscillograms

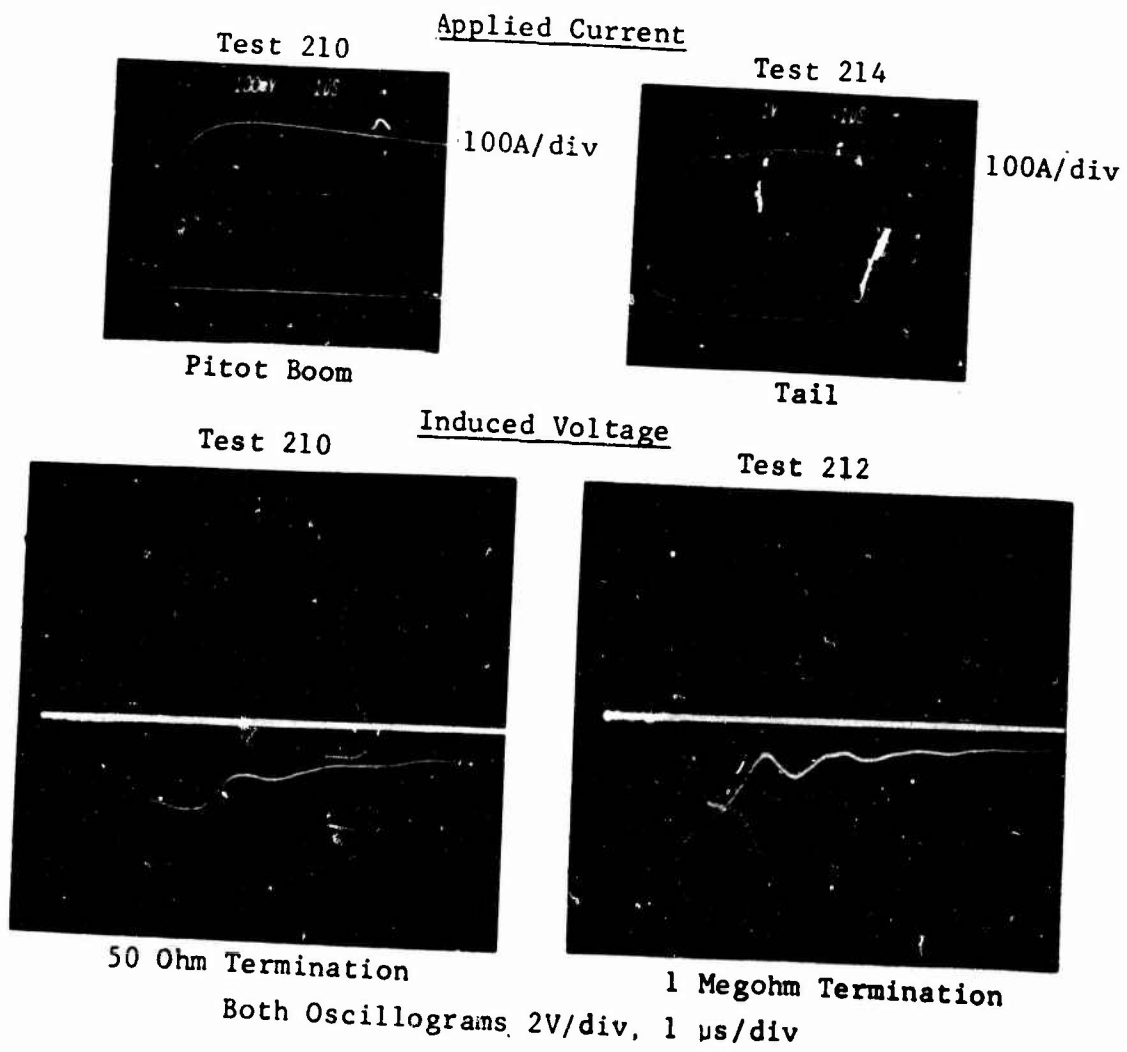

Fig. 15 - Induced Voltage Measurements 2 x 50 μs Wave

Test 235

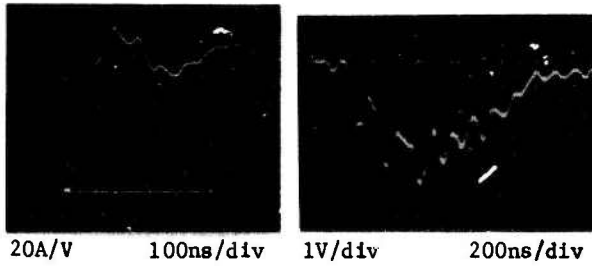
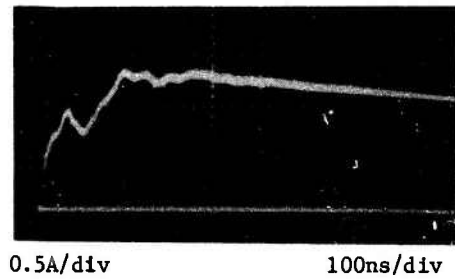

Fig. 16 - LCLN Applied Current and Induced Voltage (120 ns risetime)

Test 252



0.5A/div 100ns/div
Input Current (pitot boom)

Test 253

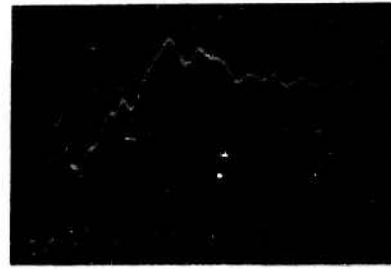

0.5A/div 100ns/div
Return Current (return conductor)

Test 238



20A/div 100ns/div

Test 238

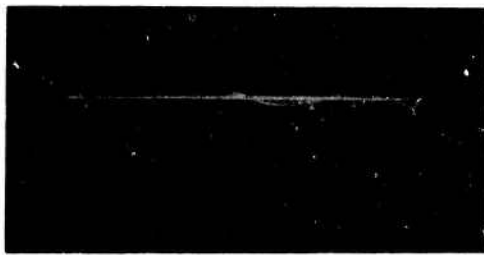

1V/div 200ns/div

Test 240

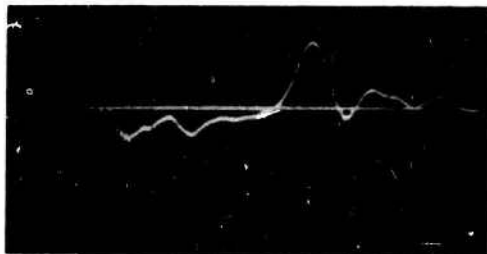

1V/div 1µs/div

Test 253

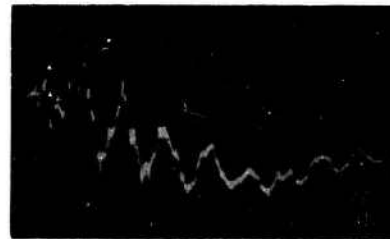

0.010V/div 100ns/div
Induced Voltage

Fig. 18 - Fast Rise Current and Induced Voltage Test

Fig. 17 - LCLN Fast Applied Current and Induced Voltage (90 ns risetime)

Test 246

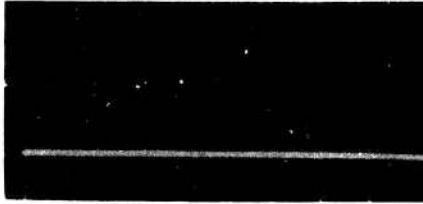

50V/div 500ns/div
50 ohm Termination

Test 248



50V/div 500ns/div
1 Megohm Termination

Test 243



50V/div 100ns/div
1 Megohm Termination

Fig. 19 - Induced Voltage Measurement Wire
Natural Frequency Tests

