

UPDATING THE MCAIR LIGHTNING
SIMULATION LABORATORY

E.H. Schulte

McDonnell Aircraft Company
McDonnell Douglas Corporation
St. Louis, Missouri 63166

AD P 0 0 2 2 2 2

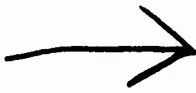

ABSTRACT

The goal of lightning simulation testing of aircraft is to ensure flight safety. The realism of each simulation is limited by the complexities of both the lightning environment and the aircraft itself. As the natural threat becomes better understood and improved test techniques are developed, the modern lightning laboratory must continually upgrade its equipment and facilities to meet the need for more accurate test simulation. This paper describes the major test improvements incorporated in the McDonnell Aircraft Company (MCAIR) lightning laboratory.

THE MCDONNELL AIRCRAFT COMPANY lightning simulation laboratory was initially developed in 1968 to provide the minimum test capability needed to qualify fighter aircraft under then existing military specifications. Over the years, the laboratory has been gradually upgraded and enlarged to include the simulation of all the important aspects of the natural lightning environment, as well as other related high-voltage and high-current phenomena. This paper summarizes the major laboratory improvements which have been implemented during the past five years to keep pace with the expanding threat definition and advanced design trends.

REASONS FOR UPDATING

Several factors have influenced the continued updating of the MCAIR lightning laboratory:

- (1) Knowledge of the natural lightning characteristics has improved.
- (2) Lightning qualification test specifications have changed. (References to lightning test components listed in this paper refer to MIL-STD-1757).
- (3) Advanced microelectronic systems pose new lightning susceptibility problems which must be evaluated by test.
- (4) New composite materials and construction techniques must be tested to verify design concepts and safety margins.
- (5) Better test realism is needed to ensure that all important test parameters are simulated.

Natural lightning is a complex and variable phenomenon which is not easily characterized. The advancements in electronic instrumentation, fast transient recorders, radar, and computing systems have enabled researchers to obtain better information about the natural lightning environment. Research flight programs and computer modeling are further extending this knowledge to encompass the interaction of lightning with aircraft in flight. One significant result of the recent research is that very fast (≈ 90 ns) rise times have been observed for the fast portions of some return strokes [1].

These submicrosecond current and field changes may present a significant hazard to aircraft because they can efficiently excite aircraft resonances which could be coupled into sensitive interior electronic systems. Flight programs have confirmed that aircraft resonances are excited by direct and nearby lightning strikes. Lightning test techniques must therefore be modified to both excite and measure the impact of such resonances.

As a result of the better understanding of lightning and its interaction with aircraft, lightning testing specifications have been revised in recent years. The major aircraft/spacecraft specifications are now MIL-STD-1757 for military aircraft [2], JSC-07636 Rev A for NASA spacecraft [3], and AC 20-53 for civilian aircraft [4]. Although these documents impose new testing requirements not previously required, they do not stipulate all of the testing which may be necessary to verify a specific protection system. A large number of tests are for research or development purposes for which test procedures and waveforms other than qualification specifications are used. Table 1 lists the wide variety of lightning tests which are conducted in a comprehensive lightning laboratory [5]. When test facilities and equipment are updated, system versatility and flexibility must be stressed so that the modified equipment can be used in a variety of tests without major changes.

Modern aircraft are becoming much more complex and sophisticated electronically. New solid-state microelectronic circuits are very sensitive to damage or upset by transients, and they are used in almost all flight control and weapon systems. In addition, the advanced composite materials used in modern aircraft have higher electrical resistances and lower electromagnetic shielding capability. The increased sensitivity of the avionics and the reduced shielding protection afforded by the aircraft structure complicate the design of lightning protection schemes. Therefore, lightning tests are required to evaluate proposed designs and to verify the protection of the final design.

The newer aircraft are using composite materials in ever increasing amounts for skins and other structural components. Airframes are thus becoming mechanically simpler because there are fewer components to be bolted, riveted, and welded together. However, they are still very complicated to design because there are now numerous selections of composite materials and layups available. There are bonded (glued) composite to composite joints, and there are bolted and riveted composite to metal joints. These new construction techniques pose new lightning protection problems not only at the strike point but all along the lightning current path through the composite and metal airframe. Although lightning protection schemes can usually be developed to protect the various composite structures, they must be evaluated by test, and the test must be closely controlled because of the different damage mechanisms of composites as compared to metals [6].

Table 1 - Lightning Simulation Test Issues

Type of Test	Test Issues	Diagnostics Required
Model Attach Point Test	Voltage Rate-of-Rise; Polarity; Gap Size; Scaling	Voltage Waveform, Photography
Full-Scale Hardware Puncture/Flashover Test	Voltage Waveform; Number of Shots; Gap Size	Voltage Waveform, Photography
Corona/Streamer Test	Voltage Waveform; Film Sensitivity; Electrode Geometry	Voltage Waveform, Photography
High-Current Damage Test	Peak Current; Action Integral; Gap Size; Electrode Geometry	Current Waveform
Continuing Current Test	Electrode Geometry; Spacing; Field Interaction; Action Integral	Current Waveform, High-Speed Photography
Swept-Stroke Test	Airstream Quality; Restrike Waveform; Continuing Current Decay	Air Uniformity; Restrike/Continuing Current Waveforms; Still/High-Speed Photography
Fuel Ignition/Spark Test	Film Sensitivity; Current Waveform; Fuel/Air Ratio	Current Waveform, Photography; Fuel/Air Mixture
Indirect Effects/Components	Peak Current; di/dt ; J_{in} ; Scaling; Component Installation; Noise-free Instrumentation; Load Impedance	Current Waveform, Induced Voltage/Current
Indirect Effects/Full Vehicle	Vehicle Isolation; di/dt ; dV/dt ; Scaling; Diagnostic Technique; Arc Channel Impedance; Wire Access	Current, Voltage Waveforms, Induced Voltage/Current

GP21-0782-2

In lightning simulation testing, the desire is always to make the test as realistic as possible. This has practical limitations, but the test must at least simulate the natural environment well enough to assure confidence in the test conclusions. Several examples of improving test realism are: (1) combining high current components A, B, C and D into one test waveform (as opposed to applying them individually to a test sample and allowing the sample to cool between tests), (2) combining components A and E or D and E (to evaluate non-linear effects such as arcing between adjacent sections on a test sample resulting from the fast rate-of-rise of the current waveform), (3) using unipolar test waveforms (as opposed to oscillatory waveforms to evaluate damage), and (4) using long arcs to the test sample (to eliminate probe effects caused by the probe being too close to the test sample).

The desire for realism has also led to the use of large aircraft sections or complete aircraft for simulated lightning tests. The use of the whole aircraft is often necessary in order to evaluate resonance effects. This has meant increasing the size of test areas to accommodate larger test sections. It has also resulted in the construction of portable generators so that tests could be conducted at remote sites when it was not possible to accommodate the aircraft in the laboratory.

A further desire of realism is to combine environments in a test. This has led to the construction and modification of equipments to obtain this test realism. For example, a swept stroke test combines the lightning arc and air blown over the aircraft surface. The lightning current should encompass the full-width current components, and the wind source should provide laminar air flow along the aircraft surface. As another example, live fuel has been used to evaluate hot spot and sparking of integral fuel tank skins struck with simulated lightning.

The MCAIR lightning laboratory has met the changing test specifications and the need for more realistic test simulation by modifying existing generators, developing and

procuring new generators, developing new test methods, procuring new electronic and photographic instrumentation, and enhancing the lightning test facilities [7]. A condensed listing of generators and equipment is given in Tables 2 and 3. The more prominent changes are described in the following sections.

ONE-MEGAJOULE/THREE-MEGAWATT LIGHTNING SIMULATOR

High-current testing at MCAIR has undergone extensive changes since it began in 1968 with only one 30-kJ, 12-kV capacitor bank. The one-megajoule/three-megawatt lightning simulator in use today is the result of gradual improvements in high-current simulation of both direct damage and induced voltage effects. Some of the simulator modifications during the past five years have included: (1) expanding individual generators and improving their operation, (2) coupling several capacitor systems together to produce the combined high-current threat waveform, (3) adding a fast current rise time to the high-peak current pulse, and (4) adding a large, pulsed DC power supply for continuing current simulation. The individual improvements are not historically described, but, instead, the operation of the present system is detailed.

The 1-MJ (actually 1.4-MJ)/3-MW lightning simulator consists of four capacitor banks (660 kJ, 192 kJ, 72 kJ, and 480 kJ) and a 3-MW pulsed DC power supply. The separate generators and the power supply are extremely versatile. They may be operated individually or in many combinations. When they are all coupled together, they readily meet or exceed the requirements of the complete MIL-STD-1757 direct-damage waveform in a single test. Figure 1 is a schematic of the combined operation. After all capacitor banks are charged and the 3-MW supply turned on, the 660-kJ bank is triggered and presents a high-voltage at its output spark gap. This spark gap closes and applies the high-voltage to the output probe. As the arc from the output probe propagates to the test sample, the 72-kJ bank triggers, so that the output of these

Table 2 - MCAIR Lightning Simulation Sources

High Current Generators ¹			
Energy (kJ)	Voltage (kV)	Current (kA)	Usage and Characteristics
660	240	300	High Peak Current Damage Tests ²
192	96	150	High Peak Current/Restrike Tests; Portable ²
72	480	200	Fast-Risetime, High-Current Tests; Portable ²
480	12	10	Intermediate and Continuing Current Tests ²
High Voltage Generators			
Voltage (kV)	Current (kA)	Energy (kJ)	Usage and Characteristics
4,000	15	40	Full-Scale Component and Large Model Tests; 20 ft Spark; Outdoor
1,650	5	4	Induced Voltage Studies; Portable
1,500	10	2.4	Remote Site Induced Voltage Tests; Modular Construction
800	25	24	Arc Attach Point Tests; Adjustable Voltage Ramp
480	20	240	Higher-Current Induced Voltage Tests; Portable
400	2	1	General Lab Use
Swept Stroke Testing			
<ul style="list-style-type: none"> ● Outdoor, 250 Knot Swept Stroke Facility Uses 240 kJ Capacitor Bank and Portable High Current Generators ● Portable, 160 Knot Blower for Low Speed Testing Used With Any High Current Generators 			
DC Power Supplies ³			
Voltage (kV)	Current (A)	Power Rating (kW)	Principal Usage
6	500	3,000	Continuing Current Damage Tests (High Coulomb) for Large Composite Structures
0.3	300	90	Continuing Current Damage Tests for Conductive Test Articles
Static Electricity Equipment			
French Injeco Device Blown Dust 400 kV DC Rectifier		<ul style="list-style-type: none"> — Compressed Air Charge Spray Gun, up to 80 μA Current — Dry Nitrogen Driven, Triboelectric Charging of Panels — Corona Spray for Electro Static Charging 	

Notes:

- 1) Smaller high current generators are available for general lab use
- 2) Generators can be integrated together to provide combined current component A, B, C and D full-thrust waveform with 2 μ sec risetime
- 3) Generator charging power supplies up to 120 kV are also available

OPS-0075.1

Table 3 - MCAIR lightning laboratory instrumentation and data processing equipment.

Item	Characteristics
Pulse Sensors <ul style="list-style-type: none"> ● EG&G: MGL-S7, MGL-6, HSD-4, CFD-1, CPM-1. ● Pearson Current Transformers: 110A, 411, 1025, 1049, 3025 ● Bell DC Current Transformer ● T&M Research Coaxial shunts: F-5000-20, F10000-40 	Skin Current, \dot{B} , \dot{D} , \dot{I} Sensors 5 kA to 250 kA 1 kA, 150 μ s Response Time 0.001, 0.0005 ohm
Fiber Optic Data Links <ul style="list-style-type: none"> ● Six MCAIR Built Units 	Battery Powered Transmitter; 25 MHz Bandwidth; Differential, High Impedance Input; Variable Voltage Gain to 150 X; Receiver Drives 50 Ω Load.
Transient Recorders <ul style="list-style-type: none"> ● Biometion B100 ● Biometion 6500 (2 Each) ● Tektronix 7612D (2 Each) ● Tektronix 7S12 	8 Bit Resolution, 2,048 Data Points, 10 ns Minimum Sampling Interval 6 Bit Resolution, 1,024 Data Points, 2 ns Minimum Sampling Interval 2 Channels, 8 Bit Resolution, 4,096 Data Points, 5 ns Minimum Sampling Interval 512 x 512 Point Matrix, 200 MHz Bandwidth
Laboratory Computers <ul style="list-style-type: none"> ● Hewlett Packard (HP) 9825 with Floppy Disk Storage, Plotter, and Printer ● Hewlett Packard (HP) 9825 with Plotter, and Printer ● North Star 	64 K Bytes of Memory; Integrated with Fiber Optic and Transient Recording Systems to Provide Computer Controlled Data Acquisition; Modem to DEC PDP 11/40 Computer 64K Bytes of Memory; Integrated with Transient Recorders for Automated Data Acquisition. 16 K Bytes of Memory; Disk Storage
Photographic Equipment <ul style="list-style-type: none"> ● Cordin Model 200 ● Cordin Model 351/326 ● Image Converter System ● Photec IV ● Four Still Cameras 	High-Speed Streak and Framing; 1 μ s Interframe Interval Streak and Framing Camera; 25,000 Frames/sec Electronic Image Intensifier Camera Both Streak and Framing Modes; (In Procurement) Movie Camera, 10,000 Frames/sec 4 in. x 5 in. Frame Size, Numerous Lenses and Associated Equipment

Note: Besides the above listed specialized equipment, the lightning laboratory has a large quantity of general purpose test equipment such as oscilloscopes, pulse generators, time domain reflectometers, etc

GP21-0471-6

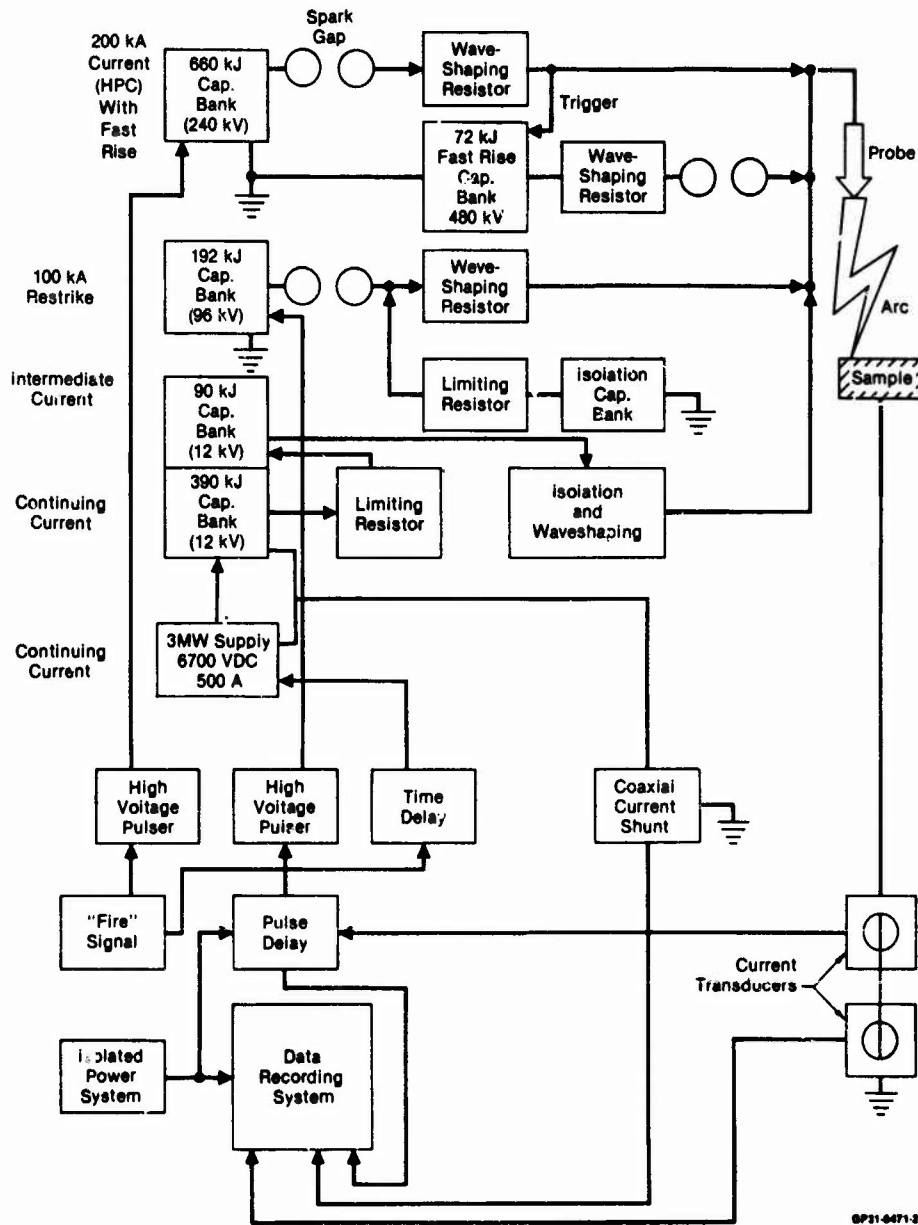

Fig. 1 - 1MJ/3MW high current simulator configured for multicomponent strike

two banks reaches the test sample at the same time. The segmented 480-kJ bank and the 3-MW supply then discharge through the established arc to the sample. The 192-kJ restrike bank is fired upon command after a preset time delay. Its output spark gap breaks down, and the generator also discharges into the test sample through the established arc path.

660-kJ CAPACITOR BANK - The 660-kJ capacitor bank consists of 220 energy storage capacitors (each 42 μF , 12 kV) connected in a Marx surge arrangement. Normally the bank is used as a ten-stage Marx generator with a per stage capacitance of 231 μF and a charge voltage of 24 kV, yielding an output voltage of 240 kV. The generator output is, however, not restricted to these values. Capacitors, or whole

stages, are easily disconnected from the electrical circuit to permit extreme flexibility in obtaining a full range of output voltages, peak currents, and pulse widths.

Because of the layout of the capacitors, the 660-kJ bank is easily separated into two five-stage Marx generators which may be used individually or paralleled to increase the output capacitance four-fold over the ten-stage configuration. The paralleled configuration (Figure 2) produces the 200-kA, $2 \times 10^6 \text{ A}^2\text{s}$ (Component A) pulse with the total energy being delivered in the first half cycle. The high output voltage of the generator permits the use of added damping resistance to control the peak current and waveshape regardless of the test article's size or resistance.

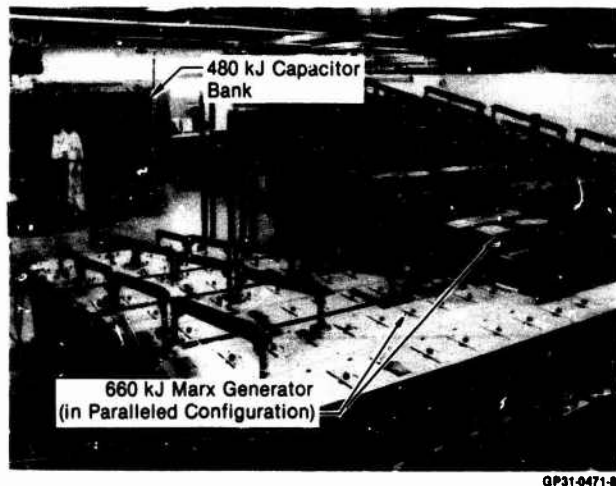

Fig. 2 - High current generators and test area

192-kJ CAPACITOR BANK - The 192-kJ (96-kV) capacitor bank is essentially a smaller portable version of the 660-kJ bank and uses the same capacitor type, charge voltage, and triggering methods. This capacitor bank is principally used to provide the 100-kA restrike current pulse (Component D) and is often combined with the 72-kJ generator when a fast current rise time is needed. Each of the generator's four stages is assembled on its own cart, so that the generator may be transported to any test location.

72-kJ FAST RISE CAPACITOR BANK - The 72-kJ, 480-kV capacitor bank is a low inductance, portable Marx generator. Each of its eight stages contain three 15 μ F 20-kV capacitors connected in series. When operated independently, the 72-kJ generator can deliver a 200-kA pulse with a 2- μ sec rise time. However, this generator is normally operated in a combined mode with either the 660- or the 192-kJ generator to provide a fast rising high-energy pulse. This bank is also useful for induced coupling tests at medium-current levels where a moderately wide waveform is needed.

480-kJ CAPACITOR BANK - The 480-kJ capacitor bank consists of 160 high-energy capacitors connected in parallel. Thirty of the capacitors are normally used to provide the intermediate current portion of a simulated lightning strike (Component B) with the remainder being used to provide a portion of the continuing current (Component C). As with the other capacitor banks, not all the capacitors or the maximum charge voltage need be utilized in all applications. The 480-kJ bank may be used independently, but it is usually utilized in conjunction with the 660-kJ bank.

3-MW POWER SUPPLY - The 3-MW high-voltage/high-current supply has a floating 6700 V DC output and is capable of providing an output of 500 amps for one second or up to 1500 coulombs in five seconds. This supply is located near the 1-MJ facility and is normally used in conjunction with it, but it can also be used independently.

The 3-MW supply requires large external resistors for current limiting. This has the advantage of making the supply appear as a constant current source to more closely approximate the characteristics of a natural lightning strike. Because of the high voltage available from this supply, the test probe can be located several inches from the test sample. The long

arc eliminates erroneous results which may be encountered when the probe is located too close to the test sample.

REMOTE LOCATION HIGH-CURRENT TESTS

High-current tests in locations other than the 1-MJ/3-MW test cell have been necessary for very large test articles or when other specialized test environments have been required. For many of these remote applications, the combination of two portable generators (the 192- and 72-kJ banks) has met the test needs. The combined system produces a 100-kA restrike pulse (Components D and E) with a 2- μ s rise time.

Figure 3 shows a portion of the high-current test setup used in tests of a full-scale mock-up of the MX missile's post-boost vehicle. (The 9-m-tall missile mock-up was housed in the large coaxial current return structure partially shown at the far right of the photo.) The purpose of the tests was to measure the external current distribution, the interior magnetic field distribution, and the induced voltage on the antennas when the missile was hit with a fast-rising, 100-kA strike.

The combination of the 192- and 72-kJ banks has also been beneficial in remote swept stroke and live fuel tests. Although the swept stroke facility and the explosion-proof test cell are located in the same building which houses the 1-MJ/3-MW simulator, safety considerations and the long cable lengths prevent the effective utilization of the 660-kJ bank with these facilities. Full-threat restrike tests (Components D, B, and C) are conducted in these facilities using the portable generators for the high-current pulse in combination with the 480-kJ bank and the 3-MW supply for the intermediate and continuing current components.

HIGH-VOLTAGE/INDUCED-VOLTAGE SIMULATORS

Although numerous high-voltage generators have been added to the lightning laboratory through the years, only the 1500-kV modular generator and the 800-kV Haefely generator are recent additions. The 1500-kV generator was developed to conduct shock-excitation induced-voltage tests on full aircraft at remote sites. The 800-kV generator was procured to conduct variable waveshape attach point tests.

1500-kV MODULAR GENERATOR - The modular Marx generator is used in induced-voltage tests and has produced 10-kA current pulses with 200 ns rise times on test articles as large as the MX missile mock-up and the AV-8B carbon epoxy wing. The generator (Figure 4) is built in 100-kV modules with each shelf being an interchangeable generator stage. Up to 15 stages can quickly be assembled using only the shelves and nylon rods for mechanical support. Each shelf contains a capacitor, three resistors, a spark gap switch, a trigger electrode, and a grading ring. Interchangeable 40-k Ω copper sulfate resistors interconnect the capacitor terminals and trigger electrodes from one stage to the next. Each stage is triggered with an electrode biased at approximately half the potential between the copper-sphere spark gap electrodes. A grading ring is used on each shelf to suppress corona and produce a smoother electric field distribution. Control of the generator system is provided by a pneumatically-operated charge/dump switch which totally isolates the generator from ground potential during firing. This switch minimizes ground loops and coupling to the power supply and provides excellent operator safety.

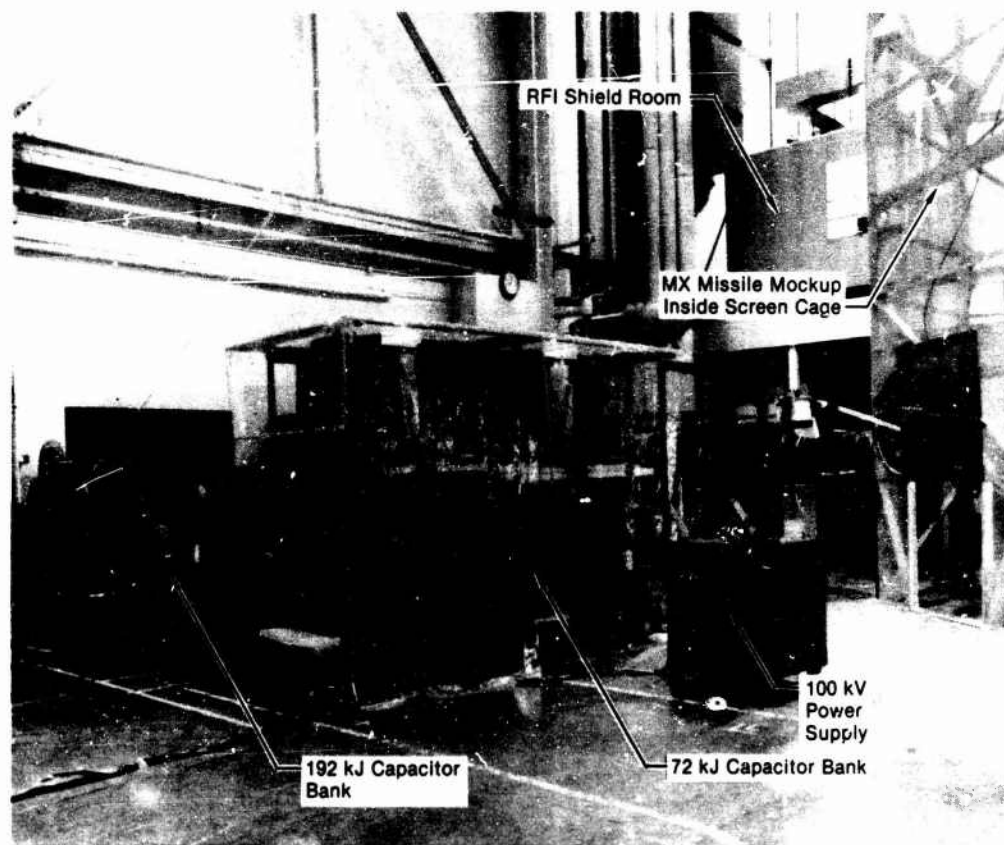

GP21-0762-8

Fig. 3 - MX missile test setup in the high voltage laboratory

800-kV HAEFELY GENERATOR – Lightning model attach point studies continue to be a controversial area of lightning testing. Many test parameters such as electrode polarity and shape, model size, arc distances, and voltage waveshape are known to affect the test results. The Haevely generator was designed to study arc propagation and the statistical arc attachment distributions as a function of the voltage rate-of-rise. The generator uses a capacitive waveshaping/voltage divider and various inductors to adjust the voltage rate-of-rise over a wide range.

REMOTE LOCATION INDUCED-VOLTAGE TESTS

In the late 1970's, the MCAIR lightning laboratory developed the shock-excitation test technique to more realistically simulate the induced-voltage responses of interior aircraft circuits to a lightning transient. The shock-excitation test technique differs from other induced-voltage test methods in that both high-voltage and high-current stimuli are applied. In the test setup, an output spark gap is inserted between the test article and the current return conductors. The test article is first charged to a high potential by a high-voltage Marx generator. Once the test article is charged, streamers form and then break down the output spark gap which quickly discharges the test article and allows the generator current to flow through the test article. The charging/discharging sequence better simulates the natural lightning strike process of the stepped leader attachment followed by a current return stroke.

The early test development centered on equipment needs, such as high-voltage dielectric insulators to isolate the test article from ground potential and fiber optic data links to measure millivolts induced-voltage responses in a test article charged to several hundred kilovolts. After this equipment was built and the test technique demonstrated in our laboratory, NASA and the US Air Force wanted several aircraft tested at remote locations. The need to conduct tests outside our laboratory required the development of the 1500-kV modular Marx generator (to replace our large high-voltage generators) and a computer-controlled data acquisition system (to simplify data taking and storage). The completely portable induced-voltage test system has been used to test the space shuttle orbiter [8], YF-16 [9], F-106B [10], and C-130 aircraft at remote locations ranging from Florida to California. The system is readily assembled in a day and is highly flexible to meet diverse test requirements.

FACILITIES AND INSTRUMENTATION

The MCAIR lightning simulation laboratory is separated into two areas. The high-voltage facility is primarily housed in a 17x26 meter high bay area of a large hangar building. With the exception of the outdoor 4-MV generator, all the generators used in this facility are movable so that facility modifications have not been required to meet changing test needs. The high-current test facility is located in a nearby building and includes the 1-MJ/3-MW test cell, a 250-knot swept stroke facility, and an explosion-proof test cell.

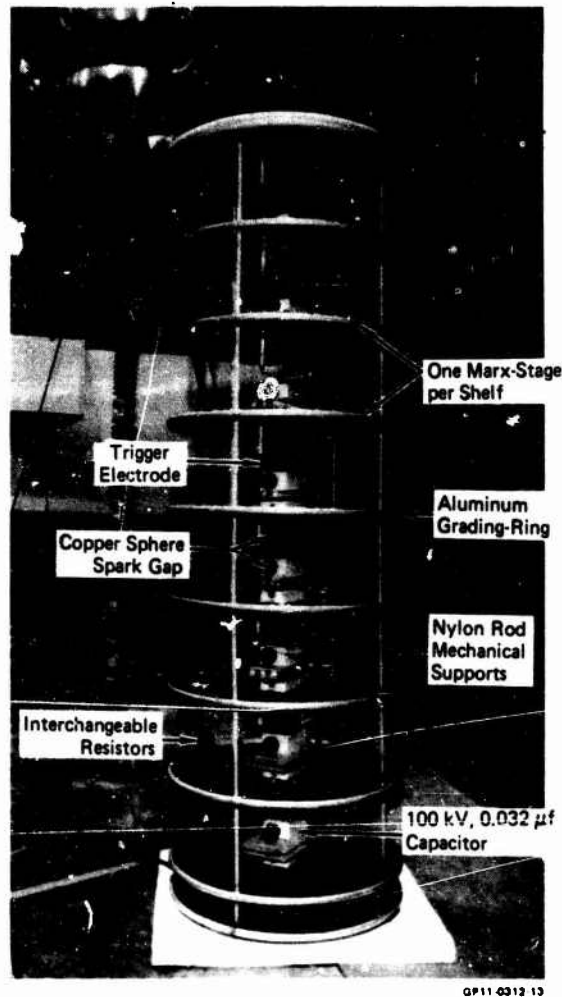

Fig. 4 - Modular high-voltage generator

The high-current lightning test area is presently being modified and enlarged to that shown in Figure 5. The facility changes are necessary to accommodate additional capacitor banks and power supplies and to increase the floor area available for large test setups. The lab area is being increased to 13x17 meters, and a 3.6 m wide door is being added to permit direct access of large test articles.

Figure 5 also shows the location of the explosion-proof test cell which is utilized when lightning tests require the use of live fuel. For these tests the portable 192- and 72-kJ high-current generators are moved to the screened test area, and the generator power supplies are moved into the test cell control room. The output of the 480-kJ capacitor bank and the 3-MW power supply are routed overhead to the screened area to provide the continuing current component of the waveform.

The 250-knot outdoor, swept stroke test facility with its 25- x 76-cm output nozzle area has not been changed. However, a portable blower system has been built for low-speed swept stroke tests up to 160 knots. The new system is powered by a 50-hp electric motor and has a large stilling chamber with a 30- x 30-cm fiber glass output nozzle. This portable system has recently been used in conjunction with the

1-MJ/3-MW lightning simulator to conduct full-energy restrike swept stroke tests on composite and aluminum wing skin panels.

The lightning laboratory has also continually updated its test instrumentation. A large variety of electromagnetic sensors, high-frequency oscilloscopes, and digital transient recorders are available. The test instrumentation is housed in either permanent or portable RFI shielded enclosures and run on isolated power lines. Still and high-speed movie cameras with numerous lens systems are used for photographic data, and computer-based acquisition systems are used for transient data taking and storage.

SUMMARY

As the knowledge of the lightning threat improves and more realistic test simulations are desired, the laboratory must change to meet these needs. The MCAIR lightning simulation laboratory has continually been upgraded to meet these needs both in the generation of the lightning test waveforms and in the measurement of the responses of the test samples.

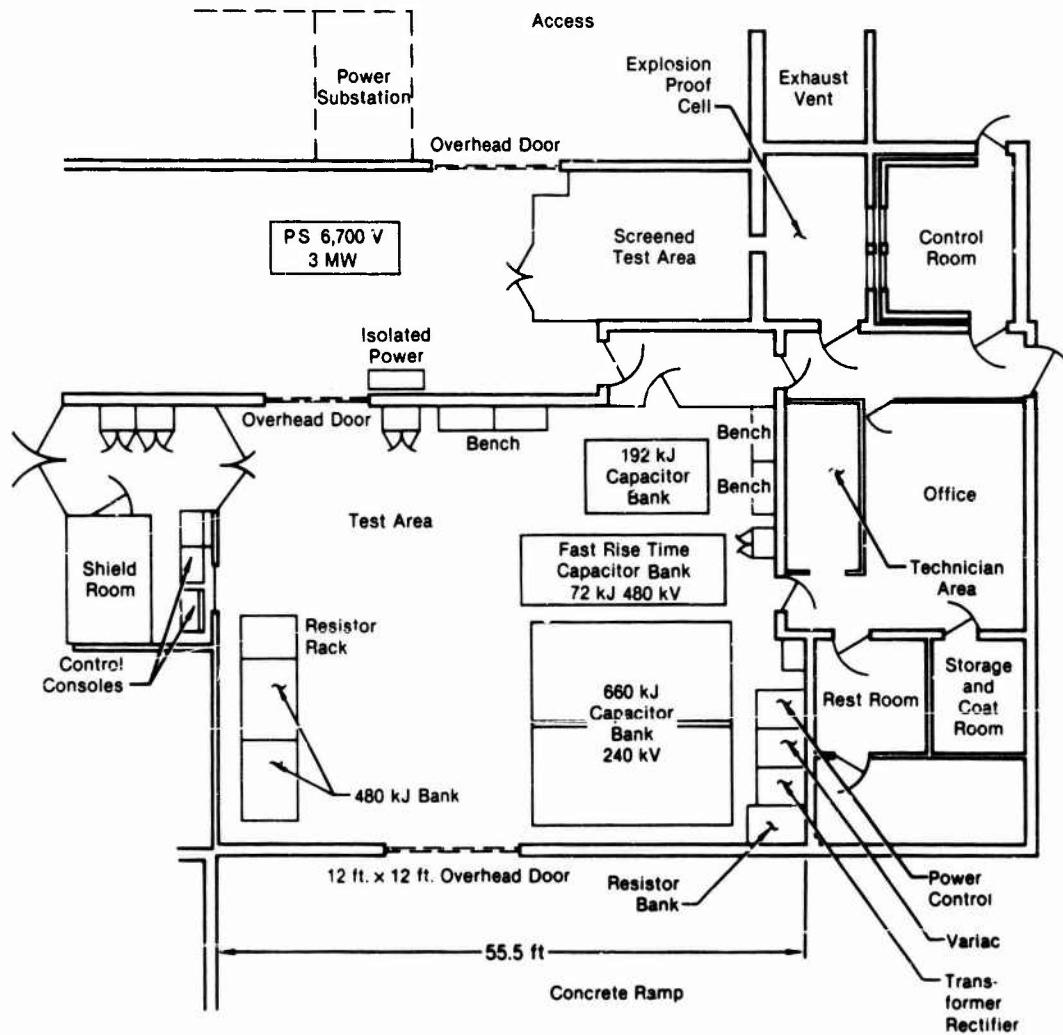

Fig. 5 - High current test areas

GP91-0471-3

REFERENCES

1. E. P. Krider and C. D. Weidman, "Submicrosecond Rise Times in Lightning Return-Stroke Fields," Geophysical Research Letters, Volume 7, page 955, November 1980.
2. "Lightning Qualification Test Techniques for Aerospace Vehicles and Hardware," MIL-STD-1757, June 17, 1980.
3. "Space Shuttle Program Lightning Protection Criteria Document," JSC-07636, Revision A, November 4, 1975.
4. "Protection of Aircraft Fuel Systems Against Lightning," FAA Advisory Circular 20-53, October 1967.
5. D. W. Clifford, K. E. Crouch, and E. H. Schulte, "Lightning Simulation and Testing," IEEE Transactions on Electromagnetic Compatibility, Vol. EMC-24, No. 2, May 1982.
6. E. H. Schulte, "Effects of Lightning Waveform Components on Graphite/Epoxy Material" Society for the Advancement of Material and Process Engineering, 23rd National Symposium, Anaheim, California, May 1978.
7. E. H. Schulte, "The MCAIR Lightning Simulation Laboratory," MCAIR Report, Revised October 1982.
8. W. G. Butters, D. W. Clifford, J. E. Lenz, and K. P. Murphy, "OV101 Orbiter Lightning Test," Report MDC A6547, August 1980.
9. W. G. Butters, D. W. Clifford, K. P. Murphy, and K. S. Zeisel, "Assessment of Lightning Simulation Test Techniques," USAF Report AFWAL-TR 3075, August 1981.
10. B. D. Heady and K. S. Zeisel, "NASA F-106B Lightning Tests," NASA Report CR-166057, January 1983.

