

UNCLASSIFIED

Defense Technical Information Center
Compilation Part Notice

ADP010422

TITLE: Supportability in Design and Low Life
Cycle Cost [LCC]: The MIRAGE 2000 Example

DISTRIBUTION: Approved for public release, distribution unlimited

This paper is part of the following report:

TITLE: Design for Low Cost Operation and Support
[la Conception en vue d'une exploitation et d'un
soutien a cout reduit]

To order the complete compilation report, use: ADA388024

The component part is provided here to allow users access to individually authored sections of proceedings, annals, symposia, ect. However, the component should be considered within the context of the overall compilation report and not as a stand-alone technical report.

The following component part numbers comprise the compilation report:

ADP010418 thru ADP010432

UNCLASSIFIED

Supportabilité en conception et faible coût global : l'exemple du MIRAGE 2000

Supportability in Design and low Life Cycle Cost (LCC) : the MIRAGE 2000 example

Louis Lemaigren, Franck Huet, Maleck Rajabaly
DASSAULT AVIATION
78, Quai Marcel Dassault
CEDEX 300
92552 Saint-Cloud Cedex
France

Résumé : Bien qu'il n'ait pas été complètement conçu, comme le RAFALE l'a été ultérieurement, à travers la démarche Soutien Logistique Intégré (SLI), le MIRAGE 2000 a bénéficié d'une forte implication de ses futurs utilisateurs dès le début de sa conception et a tiré profit du retour d'expérience opérationnelle des programmes précédents de Dassault Aviation pour lui donner les "aptitudes" d'un avion à disponibilité élevée et à très bonne maintenabilité.

L'approche globale de la "Supportabilité en conception" est présentée et la façon dont les "aptitudes" de l'avion ont été introduites au cours de sa conception est mise en relief. Les principaux choix techniques et leurs qualités de "Supportabilité" sont présentés. Les caractéristiques de soutien démontrées opérationnellement montrent comment les objectifs ont été satisfaits.

Pour une définition technique donnée, il existe plusieurs solutions logistiques pour optimiser le coût global selon les moyens du client et la taille de sa flotte sans gêner l'emploi opérationnel de sa flotte. Une optimisation de ce type à partir de simulations de coût global est présentée.

Summary : Though not fully designed, as later the RAFALE was, through a true Integrated Logistic Support (ILS) methodology, the MIRAGE 2000 received, during its design phases, a strong involvement of the future Users and took benefit of Dassault Aviation's experience and operational feedback from previous programmes to give it the "abilities" of a highly available and maintainable aircraft.

The overall approach of "Supportability in Design" is presented and the way the "capabilities" have been incorporated in the A/C definition and its evolution are highlighted. The major technical choices and their "Supportability" aspects are presented. The field-demonstrated Support characteristics show how the objectives have been met.

For a given design, different logistic solutions are possible, depending on the specific Customer and the size of his fleet, to reduce the Life Cycle Cost (LCC) without impairing the operational use of the fleet. Such an optimisation, using an LCC tool, is presented.

1 - The Integrated Logistic Support Approach

For the operational people, the quality of Support is measured through the **Availability** of the fleet (the number of aircraft ready for a mission compared to the initial number and the time it takes to perform servicing or maintenance tasks) and the amount of resources (hardware

and personnel) necessary to operate them (deployed means or **Logistic Footprint**).

For the program deciders, the quality of Support is measured through the overall cost of the function : the Life Cycle Cost (LCC).

In both cases, what is judged is not the Support alone but the efficiency of the overall System : Flying **and** Support Systems. Therefore, a good design has to consider both aspects simultaneously : it is the commonly accepted approach of Integrated Logistic Support. As Weapon and Support systems are interdependent, the process needs to be iterative and because the main choices affecting the LCC are made in the early phases of design, it is essential to apply the ILS methodology to the Preliminary Definition phases in order to incorporate Supportability into Design.

The main Measures of Effectiveness for Support are Availability, Logistic Footprint and LCC, as seen above ; they are Mission Efficiency and Vulnerability for the Flying System. Figure 1 represents the principle of the ILS process.

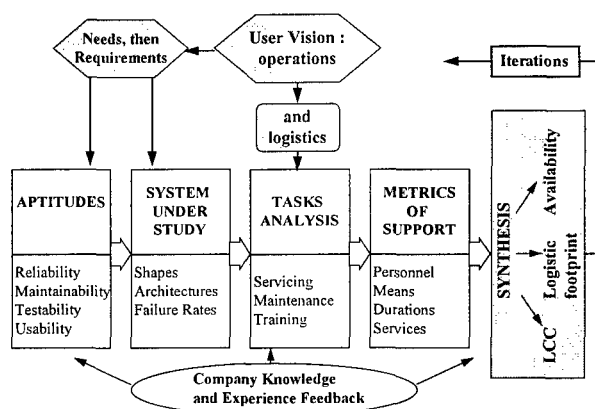

Figure 1 : The iterative process of ILS

The initial loops of the process analyse the Customer vision in terms of **needs** and **aptitudes** (or qualities) of potential systems to satisfy them with the highest Measures of Effectiveness (MoE). The next iterations, in which the needs start to become **requirements**, try to define concepts (virtual products) which could satisfy these requirements and to quantify the consequences of the technical choices on Support. The integration of the Support metrics of this virtual product allows to calculate its MoEs and to iterate either on the concept (optimisation) or on the requirements (when not achievable).

The aptitudes are the recognised **Reliability**, **Maintainability**, **Testability** (which is becoming more

important with the increasing complexity of the weapon systems) and **Usability** which is the aptitude to an easy training of the pilots and of the technicians (it affects the amount of resources, skills and time needed to be able to operate the system).

The **System under study** is a Virtual Product (digital product assembly) containing a definition of the shapes, main structural elements, floors and doors and a preliminary definition of the subsystems architectures (with reliabilities of the envisaged technologies).

The **Tasks Analysis** consists in analysing all the actions needed to operate and maintain the system. The Servicing tasks include the mission preparation and the weapon loading or replacement ; they set the product in a condition of Operational Readiness. The Maintenance tasks restore this readiness condition. The training tasks include all necessary actions to allow the personnel to properly operate the system and maintain it with the dedicated hardware. This Tasks analysis generates the **Metrics of Support** (durations of the tasks, skills of personnel, Ground Support Equipment and consumables, training means and services) allowing their integration with the proper tools into the Measures of Effectiveness **to assess the Supportability** of the concept.

The **Company knowledge** and experience feedback is used to introduce the proper Support aptitudes in the product concept and then the design rules in the product definition. Ideally, simplified formulas, based on past programs experience and on technology evaluations, should allow a fast estimation of the complexity (needed resources) and duration of the different tasks and of their costs. We are presently working on such a modelling.

Finally, the **LCC** is calculated from the list of necessary hardware, consumables and salaries established in the tasks analysis and from costs data bases ; the **Availability** is calculated from the architectures definition and the critical reliabilities (the logistic flow of spares must be simulated to have access to the dynamic availability during a campaign) and the **Logistic Footprint** is the simple integration of the resources and skills needed for a given deployment scenario.

The same sequence of tasks is performed in the Detailed Design phase but with a deeper level of definition and with additional variations on logistic scenarios to define all necessary Support components for the different potential customers. During the "In-Service" phase, iterations on the Support System options are performed to optimise the selection (logistic solution) to the Customer environment and to the size of his fleet.

2 – Supportability in the MIRAGE 2000 design :

When the MIRAGE 2000 was designed, the methodology described above was not yet formalised (and the tools necessary to perform a fast assessment of a virtual product were not available) but, in its principle, it was applied in the key decision process as shown below.

In complement to the usual involvement of the Operational pilots, as seen in the previous programs, to tailor the program requirements to the "Armée de l' Air Française" (AAF) needs, the MIRAGE 2000 program received a much stronger involvement of the Support specialists (for the requirements definition and the development), thus achieving a different balance between Performance and Support requirements.

2.1 - The needs and the aptitudes : MIRAGE 2000 program started in 1976 after the MIRAGE F1 had cumulated a significant operational experience and after the preliminary studies of the Avion de Combat Futur (ACF) which, in fact, were the feasibility studies allowing to transform the needs into requirements. Based on a different aerodynamic concept and an improved engine (the ATAR 9K50), the MIRAGE F1 had inherited most of the reliable vehicle systems of the famous Delta wing MIRAGE 3. Its operation, including the use of an Automatic Failure Localisation System called SDAP (Système de Détection Automatique de Pannes), had shown the advantages and drawbacks of different technologies and Support concepts. The needs for the new aircraft, based on the new M53 SNECMA engine, were bright performances (among which **Agility** was at the first row) but also **Robustness** (like the MIRAGE 3), **Ease of handling** (like the MIRAGE F1), **Flexibility** and variety of stores, **Reliability** and **Ease of maintenance**, including **on-board Testability** of the Weapon Delivery and Navigation System and (already !) **Affordability**. For this last essential parameter the ACF study was stopped (the AAF considered it could not afford a fleet of big twin-engines) and the specification evolved towards an agile single engine airplane. The MIRAGE 2000 development program was starting with an integration of AAF pilots and technicians and Ministry of Defence engineers in the industrial team.

2.2 - The aptitudes in the Design :

The Airframe : To satisfy these new requirements, the well proven robust and versatile Delta configuration was selected (the 58° leading edge angle selection taking benefit of the variable geometry MIRAGE G8 flight tests). Owing to the mastering of a carefree handling Fly-by-Wire flight control system able to cope with an unstable platform and to allow ease of flight and landing, an aerodynamically unstable definition was selected to give the aircraft bright manoeuvring characteristics. This platform was able to carry the required variety of loads without difficult flight envelope extension tests and able to be the basis of different versions to meet the various mission requirements, thus giving the AAF a **common affordable core for its different needs** (later the RAFALE approach will be even more ambitious allowing the replacement of different aircraft by one single versatile platform). Twin-seater versions were decided at the beginning of the program for the purpose of training or complex missions requiring a crew of two (tactical nuclear version). Structural design and doors arrangement gave a good **accessibility** to the main equipment (see figure 2 below) based on their frequency of

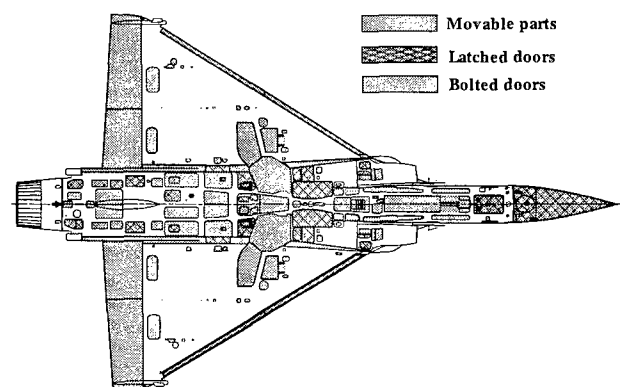

Figure 2 : MIRAGE 2000 access doors.

removal (linked to reliability) and taking into account the compromise of a low wing concept.

For the first time also the Manufacturing team was involved in the design with the first simultaneous use of CATIA in design and in manufacture, thus leading to a structural design much **cheaper to produce** than the MIRAGE 3 which looks similar in shapes. The structural dimensioning rules and the corrosion protection plan (company **robustness** tradition) gave the airframe a good Safe Life expectancy. In the prototype phase, the integrated team simulated the potential maintenance tasks and reoriented the design for an improved serviceability and maintainability. A specific effort was performed for a good **repairability** through access doors and interchangeability of major subassemblies. Later, in the flight test phase, Visits of Aptitude to "Mise en Oeuvre" (=servicing) and Maintenance (called **VAMOMs**) were performed to optimise the Supportability of the production aircraft.

The Engine : The single core/double flow M53 engine is modular by design and its replacement on the A/C had to be shorter than 2 hours with three technicians (in fact trained mechanics have demonstrated not more than 1 hour - it happened recently in a foreign country where a presentation was made).

The modular design allows a reduction in cost of spares and allows to perform most of the maintenance at O/L and I/L levels. The modules are geometrically and functionally interchangeable.

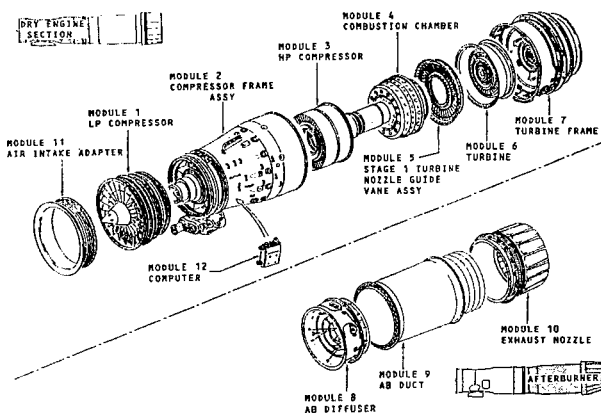

Figure 3 : Exploded view of SNECMA M53 engine

The Vehicle Systems : They were designed with the fundamental Dassault Aviation philosophy of robustness "Safe and Simple, Reliability first!" and with mostly NATO **Interoperability** requirements. The main choices are linked to a single engine configuration and the classical distribution of the primary energy source (here hydraulics for high manoeuvrability) on the engine itself and on the AMAD (Aircraft Mounted Accessory Drive). Autonomous engine start by a Turbo-Starter mounted on the AMAD.

Hydraulic redundant servoactuators for all primary flight controls (elevons and rudder) and servomotors on secondary controls (slats) with quadruplex, triplex or duplex redundancy (depending on the criticality) for the Electrical Flight Control System (EFCS) and its electrical generation.

Hydraulic system based on two 4000 PSI pumps and an electrical emergency pump and electrical shutoff valve on ancillary functions ; one circuit is dedicated to the flight

controls and nose wheel steering with a purely hydraulic irreversible emergency landing gear extension (as it is the tradition for all Dassault Aviation fighters).

Carbon brakes with hydraulic progressive control valve and redundant antiskid servovalves.

AC current delivered by two 25 kVA variable speed constant frequency (400 Hz) alternators (Varioalternators) and a standby inverter. The varioalternators take benefit of many improvements from the previous programs (MIRAGE 3, MIRAGE F1, JAGUAR, etc.). Their reliability has reached a good level though they remain complex electromechanical machines (two differential gear boxes and an Eddy current clutch to insure constant speed of the alternator). Note that, for RAFALE, as the speed ratio of the engine was smaller, a technology step was performed with the use of the variable frequency (very reliable alternators).

DC current delivered by a 40 A/hr battery and two transformer-rectifiers.

Fuel system using two forms of energy to feed the engine (electrical pumps and pressurisation) and using pressurisation for transfer. The hydro-pneumatic principle of most refuelling and transfer valves was kept from the previous programs because of its demonstrated very high reliability and safety of operation. The aircraft can carry three drop tanks and flight refuelling is performed via a STANAG 3105 refuelling probe.

Physiological protection system based on Liquid Oxygen converter (LOX) for breathing and Anti-g with purely pneumatic demand regulators (excellent demonstrated reliability). At the time, it was the only credible choice for long duration flights with refuelling. Today, to improve the maintenance aspects (logistic footprint and LCC) an On-Board Oxygen Generating System (OBOGS) is the proper choice and is the standard on RAFALE. The study of its adaptation to future versions of MIRAGE 2000 has been performed recently (the difficulties to find the proper pressure conditions to feed an OBOGS have been overcome).

Escape system based on a Martin-Baker Mk 10 seat fitted with the very good GQ Aeroconical parachute and operated by a Dassault pyrotechnic Sequence System together with the zero-delay fragilization of the transparency. Its maintenance aspects are fairly good but primary desarming is still needed for seat removal. This constraint has disappeared on RAFALE with its specific version of Mk 16 having Dassault Patent "Autoconnectors" (including pyrotechnic transfer - see Ref. 2) allowing the removal or installation of the seat with just the Safety lever raised (no connection to perform).

Environmental Control System derived from the MIRAGE F1 with the classical well proven "bootstrap" design and using as cold sources Ram Air (precooler, primary and secondary heat exchangers) and the water of an evaporator (for topping at high Mach number). Cockpit pressurisation based on purely pneumatic redundant pressure regulators. For RAFALE a much higher power demand will lead to the choice of a better performance "High Pressure water separation" principle.

To reduce the ground diagnosis time of electronic equipment, an On-board Integrated Maintenance (automatic self tests) was selected for the WDNS and for the EFCS computers as explained below. Interestingly, it was not considered necessary for all Vehicle Systems (except EFCS) in reason of the technical choices (reliability, comprehensive flight alarms, pilot reporting) and of the

previous programs experience (testability more difficult for "physical" systems and avoidance of false defects).

The Weapon Delivery and Navigation System (WDNS) :

As in any other program, it is by far the most evolutive system and the description of the different versions and their evolution towards the up-to-date MIRAGE 2000-5 and 2000-9 Systems would require a specific presentation. Without being an expert, it is obvious that the performances and mission capabilities of the initial MIRAGE 2000 C with RDM RADAR and the MIRAGE 2000-9 with RDY RADAR are very different. What is common, in terms of Supportability, is the use of Multiplex Data exchange Bus (MDB), the **On-board Integrated Testability** of the system, decided from the beginning to avoid the need of the SDAP, the Maintenance principles and organisation with 2nd level Automatic Test Equipment.

The Integrated Testability principles are the following :

- using integrity checks for every component of a unit or a functional link, rather than operation simulation
- using a centralised process to enable real-time or delayed localisation of faulty elements for on-line maintenance and, through the use of specific procedures for some I/L maintenance.

These principles have allowed :

- a drastic reduction in specific ground means for O/L maintenance (limited now to sensors and open loops)
- a very quick localisation of faulty LRUs with a very low false diagnosis rate

Two different phases can be distinguished in this Integrated "Maintenance" :

- real-time monitoring, during operational functioning, which is focused on self-tests in the units without disturbing normal operation
- on-ground complementary tests, with a specific functioning mode, allowing the execution of tests which would be too disturbing during flight.

These complementary roles of integrated maintenance have proven to be very efficient.

3 - The Maintenance Program :

3.1 - The Maintenance Development : its aim was to offer the User the maximum Availability at a minimum Life Cycle Cost by reducing the ground logistic Support through a better use of the on-board systems.

This Maintenance development was performed in four steps :

- a- **Maintainability study** including analysis on drawings and equipment of the potential maintenance actions and checking the User's rules and with operations performed on the mockups and on the prototypes (as explained above). It is the most important phase because it incorporates Supportability in the Aircraft itself (accessibility, interchangeability, removability, trouble-shooting, etc.). It allows also the specification of the Support equipment.
- b- **Analytic study of the maintenance program :** It is based on the MSG3 methodology and was called MAPIE (Méthode Analytique de définition du Plan Initial d'Entretien).

For the systems and the engine, it consists in classifying each failure consequence (depending whether it is visible or not) as critical for safety or mission or as only economic and in specifying an efficient maintenance action to prevent the failure with a given probability if it is needed and in programming this action with a periodicity in relation with

the probability of occurrence. Today we use the same methods except they are Computer Assisted (CECILIA failure Trees coming directly from the safety analyses and MAPIE AO).

For the Airframe, the study is based on Fatigue Tests (airframe and samples), on measurements and fatigue Index calculations on the aircraft and periodic inspections with Non Destructive Testing (NDT). For corrosion, the principle is similar except the theoretical projection on the future is more questionable and periodic inspections are probably unavoidable (the trick being to associate them with other maintenance actions, thus becoming nearly "transparent" for the user). The tolerance to accidental damage approach is applied mostly beyond the "Safe Life". Each type of main structural element has its inspection logic. As an example, the diagram below shows a grid for selecting the periodicity of NDT on a carbon composite structure as a function of criticality and exposure.

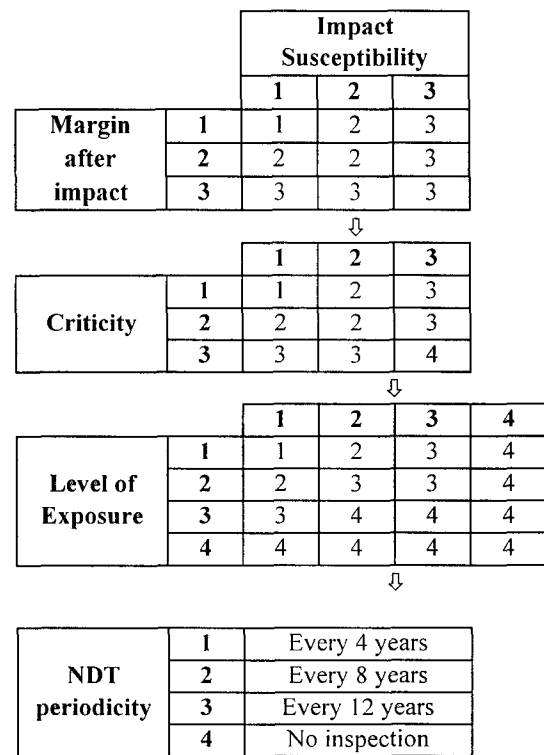

Inspections to apply on 10% of the fleet.

Figure 4 : Selection grid for impact damage

c- **Experimentation** by the AAF on the first production aircraft : it essentially validates the equipment and procedures.

d- **Program update** through technical monitoring of the customers fleets : as seen above, the maintenance program is relying on probabilities of occurrence, condition monitoring and aging studies. **Experience feedback** is a fundamental factor in its validation and improvement. The high number of flight hours in different countries and climatic conditions has led to a significant improvement of the Maintenance Program by reduction of its cost without impairing the safety.

3.2 - The Maintenance Plan :

The maintenance operations are performed at three levels :

- Organisation Level (O/L) : inside the squadron
- Intermediate Level (I/L) : specialised workshops on the Air Base
- Depot or industry Level (D/L)

Depending on the customer fleet size and existing facilities the distribution of work between I/L and D/L can be varied to optimise the LCC (see §5). The O/L activities are always flight inspections, daily servicing, operational check-out, lubrication, trouble-shooting and replacement of Line Replaceable Units (LRUs).

The I/L, which is mostly dependent on Logistic concept choice, deals with periodic inspections and minor structural repairs and replacement of Shop Replaceable Units (SRUs) or consumables.

The Maintenance Program is divided into two categories of tasks :

- "Hard Time" maintenance which is essentially preventive and which is progressively reduced with the experience feedback

- "On Condition" maintenance which is corrective and takes more and more the first place. It requires the evidence of a defect (wear, deterioration or failure) either by visual checks or by On-Board Integrated Testability or measurement of significant parameters. As explained before, for the MIRAGE 2000 vehicle systems the "Integrated Maintenance" was not selected : fault localisation is performed from alarms, indicators, the pilot's flight report and a good knowledge of simple reliable systems in which the types of failures are now well known. On RAFALE, because of different technical choices (computers for all vehicle systems, increasing pilot workload requiring an automatic management of the platform functions- see Ref.2) the On-board Integrated Maintenance is applied to the whole flying System.

Airframe maintenance : with the experience feedback from all our customers and internal studies (showing the excellent airframe behaviour), its organisation (basic, minor and reinforced inspections) has evolved to better fit the specificity of foreign customers. The inspections are performed at Intermediate Level (not at D/L). The figures below show the **present** schedule of inspections .

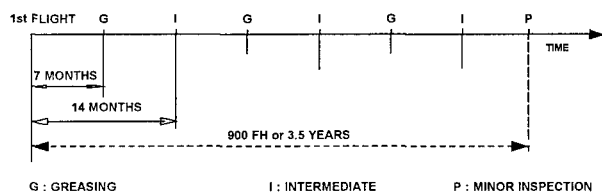

Figure 5 : Basic and minor inspections

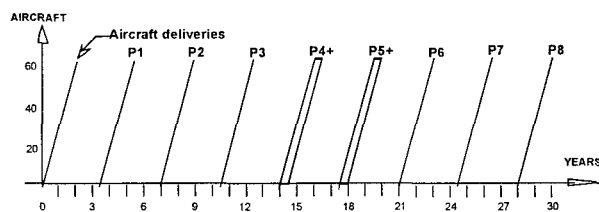

Figure 6 : Split of minor and reinforced inspections

An other important evolution under way is the transition from "fixed periodicity" P visits to flight hours related P visits, the calendar inspections being distributed on the different basic inspections.

Systems maintenance : its organisation can be varied according to customer needs. Because of their needed limited investment and their frequent use, the minimum shops are : wheels and brakes, batteries, oxygen and flight equipment, escape system and weapons. Additional shops are : FCS and hydraulics, ECS, Fuel systems, Electrical systems and turbostarter.

An Automatic Test Equipment (ATEC) can be proposed for trouble-shooting and SRU replacement and repair validation of Electronic equipment.

Engine maintenance : it consists in visual inspections on the installed engine at O/L every 150 operating hours and periodical inspections on modules at I/L (engine workshop) at 600 operating hours and then every 300 hours. The modules are replaced according to their **condition** or their remaining potential.

Engine life monitoring computers (HUMS) are now offered to take benefit of the maximum potential of the modules (and not the "safe potential" independent of what they have actually experienced). This option is clearly a cost saver. The potential is computed as a function of the mechanical fatigue, the thermal fatigue and the oligocyclic fatigue. Such a computer not only allows a reduction of maintenance cost (reduced consumption of spares), but also gives a warning of expiring potential to the mechanics.

The depth of maintenance performed by the Customer is adapted to his requirements and facilities. It includes at least engine overhaul and repairs using conventional equipment but repairs with advanced or sophisticated equipment can be proposed with SNECMA approval and confidentiality agreements.

4 - The field - proven Supportability characteristics :

Traditionally, the Air Forces do not like to see their operational parameters published. Similarly the AAF takes part to NATO exercises or joint operations which have stringent confidentiality rules . Therefore we are obliged to give only anonymous synthesized information to simply show how our systems behave. This paragraph is the shortest of the presentation but by far the most important because it gives **demonstrated** results.

After more than 750 000 hours flown, we can state that **Safety** , **Reliability** and **Maintainability** are the most obvious qualities of MIRAGE 2000 :

- Attrition rate smaller than 0.5 for 10 000 flight hours, which is excellent for a single engine aircraft. Within this rate, **only 25%** of the accidents are due to **technical** reasons, the remaining 75% being due to Human Factors (surprisingly, this distribution is similar on Civil Aircraft).

- Mean Flight Hours Between Failures MFHBF = 6.8

- Mean number of sorties without failure (France) : 5

- Direct Maintenance Hours/Flight Hour for O/L and I/L DMMH/FH= 8 to 10 depending on the exact definition of the maintenance cycle applied (about 11 demonstrated in the AAF with its organisation - see Ref 1- but with A/C towing tasks included in the servicing, 8 with the new Export Maintenance Plan based on the same tasks durations).

Another obvious measure of the overall MIRAGE 2000 Supportability is the small volume of Hardware and People deployed to operate it . Without revealing military secrets, the MIRAGE 2000 behaviour in RED FLAG exercises is

our main pride : the highest number of laurels with the smallest team and logistic footprint.

Several above figures largely exceed the qualitative Supportability Requirement which was to improve by 50% the MIRAGE F1 characteristics. They compare favorably with what we know about the competing aircraft of similar performance. They are not in contradiction with some comparisons made in open publications but the hypothesis of which must be checked carefully. For instance we saw a comparison of DMMH/FH for the highly respectable F18 and the older design MIRAGE 3 : they are simply not of the same generation and not in the same Supportability Requirements class.

5 - Optimisation of LCC :

5.1 - LCC approach

Many manuals, including LSA guides, describe the Life Cycle Cost analysis tasks, and everybody agrees on the following general decomposition of program costs :

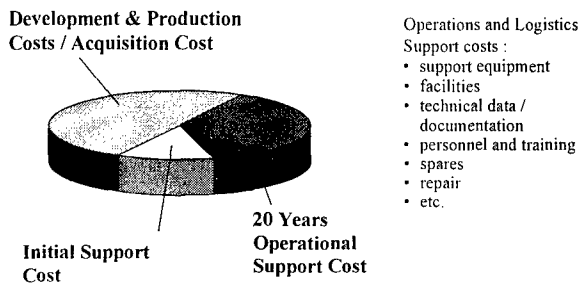

Figure 7 : Life Cycle Costs

Nowadays, most Air Forces need the cheapest operations and logistics support during the operational phase of the aircraft life without impairing the operational readiness. This is achieved with a progressive Life Cycle Cost approach through each stage of the product development. During the predevelopment phase, the operations and logistics support costs are estimated to determine at least the trends in costs evolution. Feedback of in-use systems support costs and technology evaluations are used for such an analysis.

This assessment of the system supportability would mainly call the specified aptitudes in question again. So, both the main system and its support are optimised.

At the detailed definition level, the architecture, testability and maintainability of equipment are optimised and some detailed cost models can be used for the critical equipment, mostly the less reliable.

Finally, models are used to achieve a better optimisation of the support solution for specific customer's operations and organisation in order to reduce the support costs.

5.2 - Customer Support Solution optimisation

We try to use COTS tools or models when they are not dealing with our core activity. CESAR model (Coût Efficacité du Soutien d'un système d'ARmes), developed by the "Délégation Générale pour l'Armement" (part of French MoD), is such a model.

One potential use of this steady state model is to assess the **trade-offs** between the cost of Intermediate Level facilities (electronics workshop,...) and the cost of spares and industrial services (repair, inspection,...) **allowing the user to have the same availability level.**

Entries for the calculation are :

- the aircraft logistic tree : Line Replaceable Units (LRU), Shop Replaceable Units (SRU), components,... with their aptitudes (default rate, discard rate, inspection rate,...),
- the support tasks at Organisational, Intermediate or Depot Level with their metrics (ground crew, ground support equipment, documentation, training, durations, costs,...),
- the user operations and logistics environment : aircraft's activity, aircraft's and workshops' organisation with their metrics (movement time, turn-around time,...).

It computes the level of stocks according with a security rate, the mean availability according with the average waiting time due to spares shortage and the support costs per flight hour.

The following figures show the study of trade-offs between a workshop cost and other support costs.

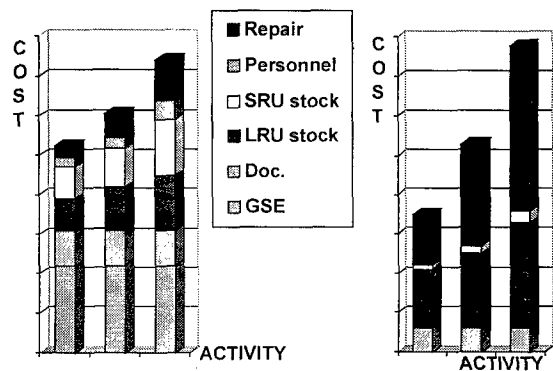

Costs with workshop Costs without workshop

Figure 8 : Electronic equipment support costs on a 15 years period

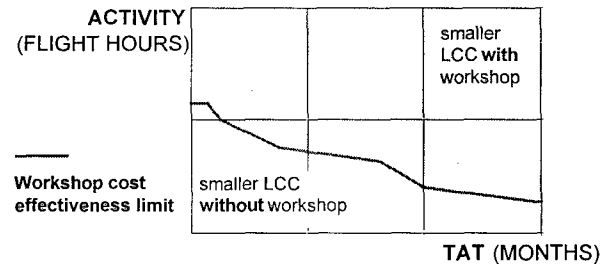

Figure 9 : Workshop cost effectiveness limit on a 15 years period

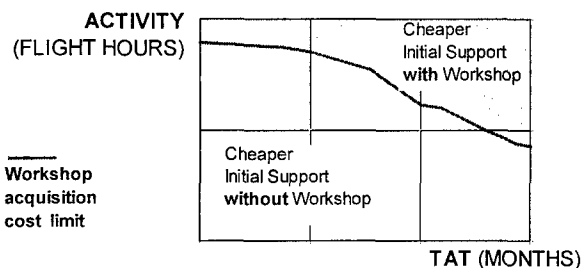

Figure 10 : Workshop acquisition cost limit for initial support

The following figure shows the study of trade-offs for different configurations of a workshop.

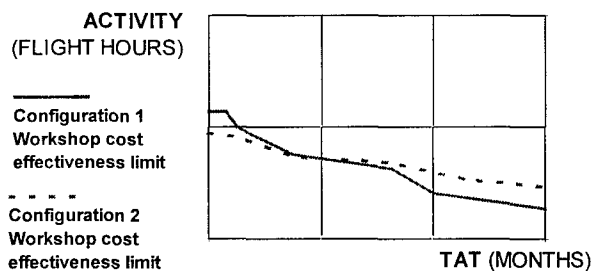

Figure 11 : Workshop's options cost effectiveness limit on a 15 years period.

With these figures, the program managers are able to decide the better purchase within economic constraints and operational needs :

- to implement the workshop as soon as possible,
- to postpone the acquisition of the workshop until a second batch of aircraft,
- to choose the best configuration of a workshop,
- or to buy industrial services.

5.3 – Cost modelling limitations.

The modelling quality depends heavily on support and costs data base.

Support data are compiled from the tasks analysis study, but you can't afford to wait for detailed data to analyse costs in the first design phases.

Likewise some approximation is used for costs because it's difficult, and expensive, to maintain up-to-date costs for all items.

For those reasons, two types of models are used :

- complete model to analyse the main factors for costs (with low level of details).
- detailed (but limited) model to optimise the important costs for the customer, among others the expense in foreign currency as opposed to local costs (personnel,...).

6- Conclusion :

Theoreticians of Logistic Support Analysis will have the satisfaction to see that this presentation does not contradict the MIL - STD - 1388-1A methodology for ILS. It has shown the importance of the user involvement and of the Support consideration in the early phases of Specification and Design. Though the methodology was not strictly formalised in documents, MIRAGE 2000 **took benefit** of this involvement for a **good Supportability in design** which has been **demonstrated** on the operational field. It has also shown that a Maintenance Plan is a living document which receives its value from experience feedback allowing to reduce the Maintenance costs without impairing safety and that further cost reductions are coming from the optimisation of the Logistic Solution to the Customer needs.

Today, owing to these actions, **MIRAGE 2000 is a proven low LCC weapon system with superb Availability**. Tomorrow, taking benefit of a true ILS Methodology, MIRAGE 2000 experience feedback and improved technologies, the twin-engine **RAFALE will rank better** in terms of Supportability. And for the day after tomorrow, as **Affordability** has to be proven before the program starts, we build the **tools** to prove the Customer that our virtual flying objects are their best future investment.

References :

- 1 - La réduction des coûts de maintenance des cellules d'avions de combat (AGARD conference - April 1997)
- 2 - The safe pilot environment of the RAFALE fighter (French Aerospace 90 conference - Washington June 1990)