

UNCLASSIFIED

Defense Technical Information Center
Compilation Part Notice

ADP010480

TITLE: An Integrated Design Procedure for
Aircraft Structure Including the Influence of
Flight Control System on Aircraft Flutter

DISTRIBUTION: Approved for public release, distribution unlimited

This paper is part of the following report:

TITLE: Structural Aspects of Flexible Aircraft
Control [les Aspects structuraux du controle
actif et flexible des aeronefs]

To order the complete compilation report, use: ADA388195

The component part is provided here to allow users access to individually authored sections of proceedings, annals, symposia, ect. However, the component should be considered within the context of the overall compilation report and not as a stand-alone technical report.

The following component part numbers comprise the compilation report:

ADP010474 thru ADP010498

UNCLASSIFIED

An Integrated Design Procedure for Aircraft Structure Including the Influence of Flight Control System on Aircraft Flutter

W. Luber, J. Becker

Daimler Benz Aerospace AG
 Military Aircraft MT24
 D-81663 Munich, Germany
 Tel.: +49-89-607-26996
 Fax: +49-89-607-28707
 email: Wolfgang.Luber@m.dasa.de

Abstract

Modern fighter aircraft are using high sophisticated power control and automatic flight control systems, which basically are designed to maneuver the airplane and to provide sufficient damping for the rigid body modes. Since the sensors are attached to the flexible structure, motions of the elastic aircraft will be measured and may influence the control system. In order to avoid instabilities it is necessary to predict the response of the aircraft with the control system and to correlate with flight test data. An analytical approach for the complete system including flight mechanics and unsteady aerodynamic forces is presented. The elastic structure is described by a set of normal modes which have been updated by results of ground resonance survey tests. Flutter calculations in open and closed loop on different flight conditions as well as incidence variations are demonstrated as common flutter plots. For the flutter analysis a set of notch filter is required, which should be determined in an integrated design step.

1. Introduction

The Eurofighter EF2000 will be developed and produced within a four national cooperation. Such a multi national cooperation requires special agreements of system design responsibilities (SDR). The design and development of a component is done by the partner company (PC) who manufactures this component. The overall design activities are shared between partners with SDR for e.g. flutter with and without FCS and with and without carrying stores. The structural design of an aircraft evolves through several stages where the conflicting requirements of weight, stiffness, flight control system, flutter, cost,

serviceability, etc. are matched to the required degree.

During this period a number of structural models might be created to assist in the design and development process. Each model would use the best available information on structural configuration and sizes, aerodynamic loads, the distribution of mass, flight parameters etc.

Once the design has stabilized a final model of the complete aircraft structure is created to verify structural integrity and the flexural characteristics.

The final model for the development phase the checkstress model was to embody the 'best possible representation of the actual aircraft'. The procedure of assembling the components to the dynamic model will be described.

Figure 1 shows the two side view of the aircraft.

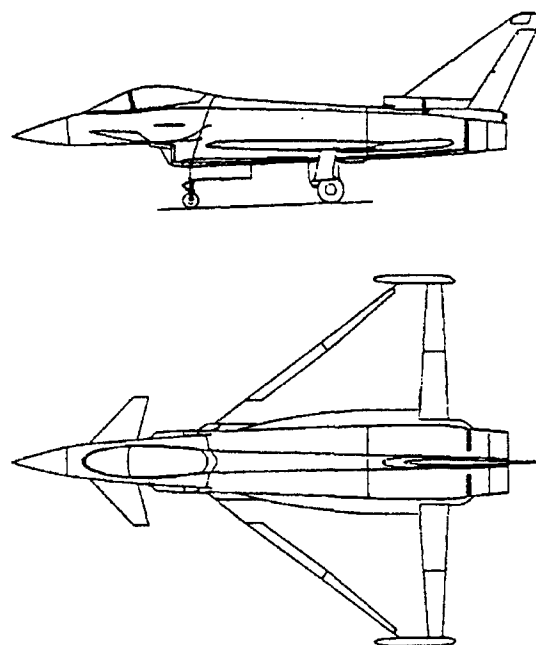

Figure 1: Two side view of the Aircraft

Due to the fly by wire system the advanced digital flight control system for a modern military aircraft is strongly influenced by aeroservoelastic effects. The flexible aircraft behavior especially for artificial unstable aircraft configurations with outer wing missiles, tip pods and heavy under wing stores and tanks has significant effects on the flight control system. The signals of the Aircraft Motion Sensor Unit (AMSU) - the gyro platform - contain besides the necessary information of rigid aircraft rates and accelerations also flexible aircraft rates and accelerations in the frequencies of the aircraft elastic modes. The 'flexible' aircraft rates and accelerations measured by the inertia measuring unit (IMU) are passed through the flight control system control paths, they are multiplied by the FCS gains and FCS filters and inserted in the control surface actuator input which then drives the controls in the frequencies of the elastic modes of the aircraft. The flexible aircraft is excited by the high frequency control deflections and might also experience aeroservoelastic instabilities i.e. flutter or limit cycle oscillations may occur, and dynamic load and fatigue load problems can arise. The FCS design therefore has to minimize all structural coupling effects through the available means like optimum sensor positioning, notch filtering and additional active control. This paper describes the aeroservoelastic work and problem areas which must be considered during the clearance work for an artificial unstable aircraft. Many of the design and clearance aspects have been published in previous papers, Ref.'s ^(1,4,8-11,15,16). For integrated design of notch and phase advanced filters see Ref.⁽²⁾, for unsteady aerodynamic see Ref. ^(8,12-14) and for testing and qualification Ref. ^(3,5-7)

2. Aeroservoelastic design requirements, Philosophy to get certification

2.1 Design Requirements

2.1.1 Flutter Requirements

Analyses, wind tunnel tests, and airplane ground and flight tests up to design limit speeds shall demonstrate that flutter, buzz, divergence and other related aeroelastic or aeroservoelastic instability boundaries occur outside the 1.15 times design limit speed envelope.

Figure 2 summarizes the requirements and evidence required for qualification and certification of a typical military aircraft.

D:\DGLR98\require3a.flo

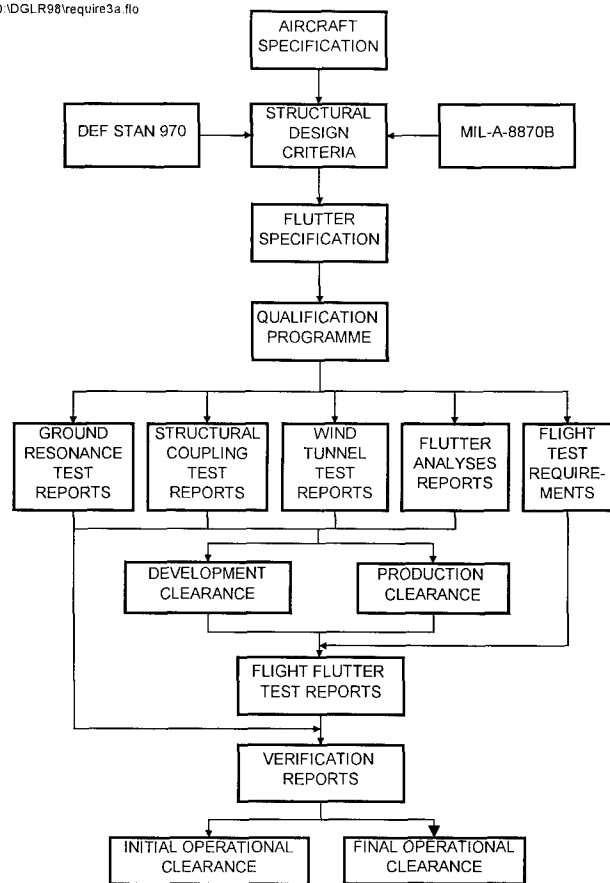

Figure 2: Requirement for Qualification

The flutter requirements are mainly derived from the U.S.-MIL-SPEC and the British DEF-STAN documents.

From these documents specific requirements for airspeed margins, aeroelastic and aeroservoelastic stability requirements can be derived.

Therefore the aircraft shall meet the following stability design requirements for both normal and emergency conditions.

- **Margin:**
Fifteen percent equivalent airspeed margin on the applicable design limit speed envelope, both at constant altitude and constant Mach number.
- **Clean Aircraft Damping:**
The damping coefficient g (structural damping) for any critical flutter mode or for any significant dynamic response mode shall be at least three percent for all altitudes on flight speeds up to design limit speed.

- Aircraft with Stores Damping:
Critical flutter modes whose zero airspeed damping is less than 3% 'g', the damping coefficient 'g' need only be greater than the zero airspeed damping coefficient in that mode.

The full requirements of the specification are subjected to the MIL-A-8870B, Airplane Strength and Rigidity Vibration, Flutter, and Divergence.

For the first flight standard the DEF-STAN was adapted:

The clean aircraft shall be allowed to fly up to half calculated flutter speed for any critical flutter mode. The aircraft with stores shall be allowed to fly up to the minimum of half calculated flutter airspeed and half required airspeed.

It should be mentioned that the calculated flutter airspeed includes validation of the theoretical model by ground testing. After first flight the expansion of the flight envelope is based on theoretical analysis with flight test results.

2.1.2 Aeroservoelastic Stability Requirements

Interaction of the control system with aircraft elastic modes shall be controlled to preclude any structural coupling. Structural coupling is a phenomenon associated with the introduction of the closed loop control system into flexible aircraft structure.

The equivalent airspeed margin and damping requirements shall be met with the FCS open and closed loop. In addition, the stability margin of the flutter system shall respect the structural frequency stability margins in the flight control system requirements.

The aeroservoelastic design requirements are primarily stability requirements for all flight control rigid/flexible aircraft modes. The stability is achieved by the introduction of notch filters. The open loop frequency response requirements are demonstrated in Figure 3, which describes gain and phase margins for production aircraft for configurations which are flight tested on prototypes including structural coupling flight tests. In contrary to the production criteria a more conservative clearance requirement was established for the prototype aircraft, Figure 4. For the initial phases of the prototype program the decision was made to a 9 dB stability margin requirement for all structural mode frequencies. The first frequency of the low flexible modes are phase stabilized and higher frequency flexible modes are gain stabilized.

The Military Specification MIL-F-9490 D for FCS requirements shall be met, the design boundaries, which include rigid aircraft motion, structural elastic modes and system modes.

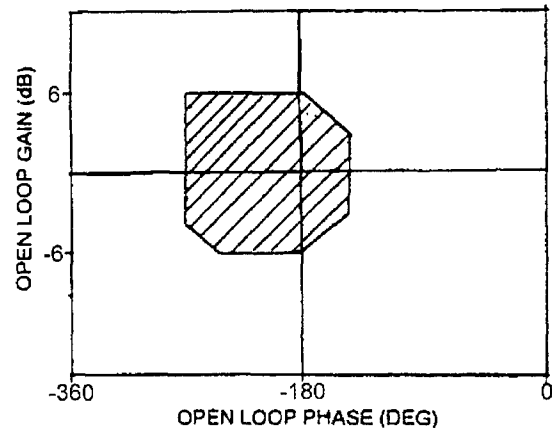

Figure 3: Production Stability Margin Criteria for Open Loop Frequency Response Function

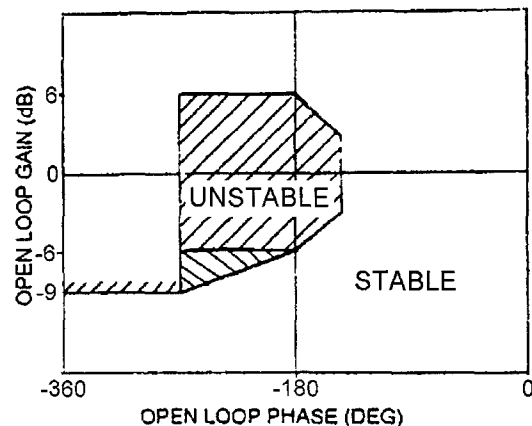

Figure 4: Prototype Stability Margin Criteria for Open Loop Frequency Response Function

2.1.3 Vibration/Dynamic Loads Requirements

In addition to the stability requirements for the structural coupling unacceptable vibration levels must be avoided including noise levels. The vibration levels induced by structural coupling might create high fatigue loads to actuators and to aircraft structure. The notch filters together with noise filters have to be designed to meet the specific vibration requirements.

2.1.4 Backlash Requirements

Aircraft backlash ground tests are required on all control surfaces to meet the flutter MIL-SPEC Requirements:

Flaperons: Outboard 0.0022 Radians (pitch)
Inboard 0.0200 Radians (pitch)

Foreplane: 0.0006 Radians (Pitch)

Rudder: 0.0022 Radians (yaw)

For normal operation and during steady flight, the flight control system induced aircraft residual oscillations at the crew station shall not exceed 0.04 g's vertical acceleration. For a typical unstable aircraft configuration the FCS backlash requirement for the flaperon and foreplane is 0.0006 Radians.

2.2 Design philosophy for aeroservoelasticity

Aeroservoelasticity or also called FCS-structural coupling is a phenomenon associated with the introduction of a closed loop flight control system into a flexible airframe. The system might be provided to enhance the natural stability of the aircraft, or, to provide artificial stability to a configuration which has been designed to be unstable to achieve the aerodynamic system specification.

For solution of the structural coupling problem, attenuation of the high frequency oscillatory signal introduced into the flight control system by the flexible aircraft motion should be provided and notched, such that the closed loop is stable and degradation of the performance of the flight control system, or damage of the aircraft structure, is avoided.

Therefore an integrated design shall include the derivation of FCS gains, phase advance filters and notch filters to minimize structural coupling in one combined optimization process. The FCS shall be designed to cover the full rigid, flexible aircraft frequency range with respect to aircraft rigid mode and structural mode coupling stability requirements for each control system individual loop for on ground and in flight. The structural coupling influences shall be minimized by FCS notch filters. The FCS shall be designed to be as robust as possible with respect to all possible aircraft configurations and configuration changes, (missiles on, off, tanks on and off etc.). That includes that all structural coupling changes with configuration should be covered by a constant set of notch filters to avoid system complexity due to configuration switches for different sets of notch filters. In addition any scheduling of notch filters with flight conditions should be avoided in a wide range of the flight envelope but not excluded for critical

structural coupling areas. In order to avoid problems in the notch filter design due to non-linear unsteady elastic mode and control surface aerodynamics and non-linear actuator dynamics the elastic mode stability requirements should mainly be based on gain stabilization of the flexible modes. Phase stabilization shall only be applied to low frequency elastic modes in order not to create too complex design and clearance procedures. Phase stabilization of low frequency elastic modes might not be avoided, it is used as tool to meet handling requirements.

The notch filter design can be based upon an analytical model of the aircraft structure including a linear FCS model. The analytical model must however be verified through ground test results both from ground resonance and structural coupling testing and from in flight flutter and structural coupling testing. The model should be updated by the test results for different configurations. Due to restrictions in the accuracy of the analytical model predictions on ground and in flight mainly at high frequency elastic modes where the prediction becomes more and more unrealistic the analytical model data with respect to inertia shall be replaced by on ground measured data. In order to cover all possible sets of aircraft store configurations a selection of critical configuration has to be established by analytical model investigation in advance.

The most critical selected configurations have to be introduced into the design of the structural filters.

The integrated FCS gain, phase advance filter and notch filter design shall cover the full range of stores and fuel states for the absolute worst case of FCS gain for trimmed aircraft conditions and shall also take into account worst gain situations in out of trim conditions.

2.3 Qualification and Certification

For flutter and structural modes coupling stability it is required to provide evidence of Qualification to prove that the aircraft is free from structural instabilities and to ensure safe flight, necessary for the flight testing task and verification against the specification.

As mentioned before, qualification is to demonstrate that the aircraft shall be free from flutter and aeroservoelastic instabilities at speed up to 1.15 times the maximum airspeed and the maximum Machnumber for all flight conditions.

Flutter and Aeroservoelastic qualification is achieved by:

- **Theoretical calculations:**
Including the characteristics of the Flight Control System for all possible configurations (clean and with external stores) as well as failure cases.
Supported by:
 - **Ground Tests:**
Ground vibration and resonance tests on components and completed aircraft, structural mode coupling tests, actuator impedance tests, static stiffness tests and backlash tests.
 - **Wind tunnel Tests:**
Flexible and rigid model testing, with dynamic similar models
 - **Flight Tests:**
Vibration and flutter flight tests and inflight structural mode coupling tests.

Figure 5 shows in principle the aeroelastic stability qualification route to flight clearance.

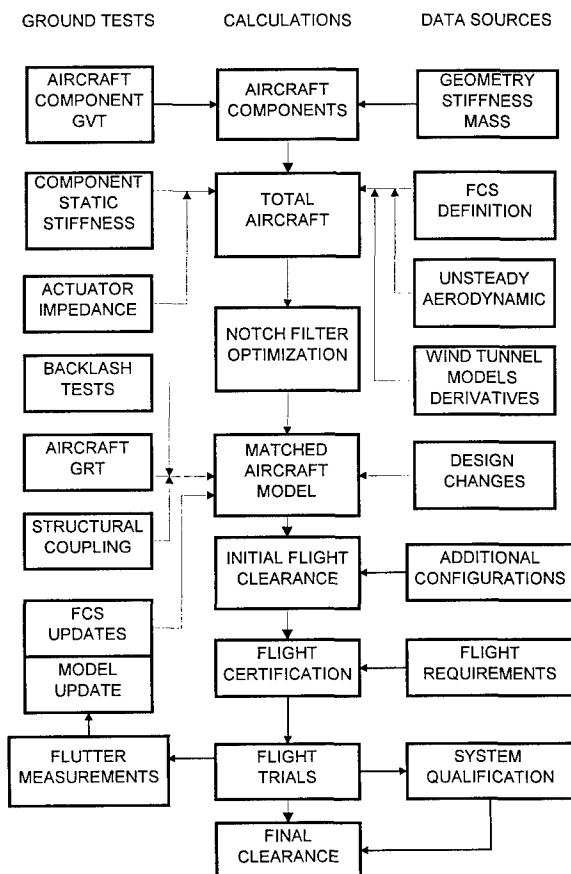

Figure 5: Flight Certification Route

Theoretical Models

The aeroelastic and aeroservoelastic models are based on a theoretical finite element model representative of the stiffness and mass characteristics of the actual aircraft, by means of dynamic assembly. The complete flutter model is assembled using the dynamic model by components and includes unsteady aerodynamic forces to analyze the aeroelastic stability characteristics of the aircraft. Sensitivity studies are performed to investigate parameter and failure variations (e.g. store and fuel mass, attachment stiffness and FCS configurations).

Validation of Models by Ground Testing

Stiffness and mass data of the theoretical aircraft model will be validated by component and total aircraft ground vibration tests. Ground vibration testing is performed on components, like wing, fin, foreplane, pylons and on fully assembled aircraft a ground resonance test (including hydraulic system) is performed.

Static stiffness testing is performed on selected combinations of pylon and store configurations and impedance actuator testing covering single and dual hydraulic system working as well as failure cases. Where any definite difference exists between the tests and predictions derived from the theoretical models, the models are updated to account for the results of the ground testing.

In general, the result of ground testing will be a validated aeroelastic model which is the basis for predicting flutter characteristics for selected key configurations.

Validation of Models by Flight Testing

The main validation of the flutter model is made with flight flutter testing, and this model is used to derive clearances up to the required 115% of the design speed envelope. The flight flutter tested key configurations establish measured data, which are compared with the theoretical results. Where any differences reveal, the models will be adjusted to account for the results of the measurements. The flight envelope expansion is done by a Machnumber/airspeed survey. In the beginning phase of flight flutter testing, the test will be concentrated on areas with high flutter stability. When the measurement of frequency and damping shows a more conservative flutter onset or confirms the predicted flutter point, the test in of more critical points will be performed. In case of fundamental differences to the predictions, the test will be interrupted and the differences are investigated and the models are updated.

2.4 Aeroservoelastic Design Tools

The integrated FCS design for the flexible aircraft is possible with the assumption that the aircraft characteristics are predictable to the necessary accuracy to optimize notch filters which meet the requirements. The characteristics of the controlled flexible aircraft shall be described in the form of open loop frequency transfer functions of the FCS control path feedback loops to a sufficient high frequency, see block diagram in Figure 9 for longitudinal and Figure 10 for lateral control. In detail for the longitudinal control system the pitch rate, the normal acceleration and the flow sensor α open loop signal at the control opening point has to be known. For the lateral control the roll rate -, yaw rate-, lateral acceleration - and flow sensor signal β open loop signal has to be described. The open loop signal consists of the transfer function of the aircraft due to control surface input sensed at the inertia measuring unit (rates and accelerations) and at the flow sensors, and the transferfunction of the FCS from the sensor to the opening point and from the opening point to the actuators.

The individual transfer function can be derived from two different methods the first using the analytical dynamic model calculation, the second using on ground measured sensor to actuator input transfer functions from the structural coupling test superimposed with calculated magnitudes of unsteady aerodynamic transfer functions. The applicability of the analytical dynamic model calculation depends on the accuracy of the modeling and its verification. Both methods depend on the accuracy of the unsteady aerodynamic transfer functions which are in both methods derived from theoretical predictions of unsteady aerodynamics for elastic modes and control surface deflection.

3. Analytical Model of the Flexible Aircraft with Flight Control System

The analytical model of the flexible aircraft with FCS consists of the linear dynamic description of the flight mechanic equations of motion, the description of the flexible aircraft through modal description using generalized coordinates, generalized masses, stiffness and model structural damping and generalized aerodynamic forces of the flexible modes and generalized control surface inertia and unsteady aerodynamic terms, the FCS is described through linear differential equations. In addition hardware and software, i.e. all sensors,

actuators, computer characteristics are described by differential equations. The flexible aircraft with FCS can be demonstrated in a matrix form.

Assuming linear behavior of the structure the flutter equations of an non-augmented aeroelastic system can be written in matrix differential equation form:

$$m_r b_r^2 \begin{bmatrix} M_{q\dot{q}} & M_{q\delta} \\ M_{\dot{q}q} & M_{\dot{q}\delta} \end{bmatrix} \begin{Bmatrix} \dot{q} \\ \dot{\delta} \end{Bmatrix} + \frac{s_R}{kV} \left\{ \omega_r^2 m_r b_r^2 \begin{bmatrix} gK_{q\dot{q}} & 0 \\ 0 & K_{\delta\delta}'' \end{bmatrix} + \frac{\rho}{2} V^2 F s_R \frac{b_r}{s_R} \begin{bmatrix} C_{q\dot{q}}'' & C_{q\delta}'' \\ C_{\dot{q}q}'' & C_{\dot{q}\delta}'' \end{bmatrix} \right\} \begin{Bmatrix} \dot{q} \\ \dot{\delta} \end{Bmatrix} + \left\{ \omega_r^2 m_r b_r^2 \begin{bmatrix} K_{q\dot{q}} & 0 \\ 0 & K_{\delta\delta}' \end{bmatrix} + \frac{\rho}{2} V^2 F s_R \frac{b_r}{s_R} \begin{bmatrix} C_{q\dot{q}}' & C_{q\delta}' \\ C_{\dot{q}q}' & C_{\dot{q}\delta}' \end{bmatrix} \right\} \begin{Bmatrix} q \\ \delta \end{Bmatrix} = \{Q(t)\} \quad [1]$$

where m_r , b_r and ω_r are the reference mass, length and frequency and M , K and C are referred to as the generalized mass, stiffness and aerodynamic matrices which are nondimensional. The generalized mass and stiffness matrices are calculated using a finite element mode (FEM) of the total aircraft. For dynamic response calculation the FEM is reduced to representative generalized dynamic DOF's. The true airspeed V and semispan s_R of the reference plane are used to form the reduced frequency $k = (\omega s_R)/V$. F is the area of reference plane and g is the structural damping of the elastic modes. The generalized forces $Q(t)$ are equal to zero for the conventional flutter problem. The generalized coordinate q describes the amplitude of the elastic airplane modes including elastic control surface modes for a system with actuators whereas δ_0 denotes the rotation of the rigid control surface according to the complex actuator stiffness represented by the impedance function of equation (2).

$$K_{\delta_0, \delta_0} = K'_{\delta_0, \delta_0} + iK''_{\delta_0, \delta_0} \quad [2]$$

For the controlled aircraft the servo-induced control deflection $\Delta\delta$ has to be introduced as an additional degree of freedom for each control surface. The generalized forces generated by the servo induced control deflections $\Delta\delta$ can be described as the right-hand term of equation (1) by

$$\{Q(t)\} = -m_r b_r^2 \begin{Bmatrix} M_{q\Delta\delta} \\ M_{\delta_0\Delta\delta} \end{Bmatrix} \Delta\ddot{\delta} - \frac{\rho}{2} V^2 F s_R \frac{b_r}{s_R} \frac{s_R}{k \cdot V} \begin{Bmatrix} C_{q\Delta\delta}'' \\ C_{\delta_0\Delta\delta}'' \end{Bmatrix} \Delta\dot{\delta} - \frac{\rho}{2} V^2 F s_R \frac{b_r}{s_R} \begin{Bmatrix} C_{q\Delta\delta}' \\ C_{\delta_0\Delta\delta}' \end{Bmatrix} \Delta\delta \quad [3]$$

Assuming normalized rigid control surface modes δ_0 and $\Delta\delta$, the rotation of each control surface can be superimposed by

$$\delta = \delta_0 + \Delta\delta \quad [4]$$

δ is used here as abbreviation of foreplane, inboard and outboard flap or for rudder, and differential inboard and outboard flap.

Closed loop analysis:

For each control loop the motion of the structure picked up by the sensor can be expressed in terms of the gyro station and the generalized coordinates.

$$x_s = \Phi_{xs} \cdot \dot{q} \quad [5]$$

The relation between the servo induced control surface deflections and the structural displacements sensed by the IMU are described as:

$$\Delta\delta = F_{Servo} \cdot F_{FCS} \cdot F_{Servo} \cdot x_s \quad [6]$$

where the transferfunction of the FCS also includes existing interfaces between the individual control loops. Combination of the above equations, the control surface deflection $\Delta\delta$ can be expressed by a transfer matrix which contains the properties of the interconnected control loops and the modal velocities, or displacements or accelerations at the sensor station.

With the assumptions

$$q(t) = \hat{q} \cdot e^{pt} \quad [7]$$

the equation can be transformed into frequency domain.

Open loop analysis:

In case of open loop analysis the signal is cut off behind the sensor. This means for the flutter analysis no feedback of the control surface motion and the classical solution can be applied, and for the structural coupling analysis a harmonic oscillating electrical input signal with constant amplitude for different frequencies. The deflection of the single input can then be calculated.

With the inclusion of the flight control system into the flutter stability calculation, analysis methods and aspects of control engineering have to be introduced. These methods are considerably different from the classical aeroelastic methods.

The state-space-description of the dynamic equation describing the aeroservoelastic behavior is as follows:

$$\{\dot{X}\} = [A]\{X\} + [B]\{x_i\} \quad [8]$$

where:

A	Dynamic matrices
B	Input matrices
u	Input quantities
X	State Vector

The matrix in equation (1) describing the flexible aircraft with FCS is enlarged by linearized rigid flight mechanic equations. For example the state vector for longitudinal control includes then rigid aircraft state variables

$$X = [\Delta V/V; \Delta\alpha; \Delta\omega; \Delta\theta; \dot{q}; \dot{\delta}_0; \Delta\dot{\delta}; q; \delta_0; \Delta\delta] \quad [9]$$

The flight mechanic equations may in a first approximation contain elastified aerodynamic derivatives as function of incidence, Mach number and they are for low frequency assumed to be decoupled from the flexible aircraft equations. In another approximation the flight mechanic equations are fully rigid and theoretical inertia and unsteady aerodynamic coefficients are introduced. The flight mechanic equations for longitudinal control are described below:

Rigid aircraft equation with flexible coupling terms Normal Force equation

$$\begin{aligned} \sum Z = & -\frac{\rho}{2} V^2 F [C'_{z\alpha}(\omega) \cdot \alpha + C''_{z\alpha}(\omega) / \omega \cdot \dot{\alpha}] \\ & - mV \cos(\alpha\omega_y) - \frac{\rho}{2} V^2 F \cdot \bar{c} [C'_{zq}(\omega) \cdot \omega_y + C''_{zq}(\omega) \cdot \dot{\omega}_y] \\ & - mg \sin(\alpha\theta) \\ & - \frac{\rho}{2} V^2 F [C'_{z\delta}(\omega) \cdot \delta + C''_{z\delta}(\omega) / \omega \cdot \dot{\delta}] - Z_{m\delta} \cdot \ddot{\delta} \\ & - \frac{\rho}{2} V^2 F \left[\sum_j C'_{zqj}(\omega) q_j + \sum_j C''_{zqj}(\omega) \dot{q}_j \right] = 0 \quad [10] \end{aligned}$$

Elastified normal force 'rigid' aircraft equation

$$\begin{aligned} \sum Z = & -\frac{\rho}{2} V^2 F \cdot C_{zq}(\alpha) \alpha - mV \cos(\alpha\omega_y) \\ & - \frac{\rho}{2} V^2 F \cdot \bar{c} C_{zq} \omega_y - mg \sin(\alpha\theta) - \frac{\rho}{2} V^2 F \cdot C_{z\delta}(\alpha) \delta = 0 \quad [11] \end{aligned}$$

Pitch Moment equation with flexible coupling terms

$$\begin{aligned}
\sum M = & -\frac{\rho}{2}V^2F \cdot \bar{c} [C'_{m\alpha}(\omega)\alpha + C''_{m\alpha}(\omega)\dot{\alpha}] \\
& -I_y\dot{\omega}_y - \frac{\rho}{2}V^2F \cdot \bar{c}^2 [C'_{mq}(\omega)\omega_y + C''_{mq}(\omega)\dot{\omega}_y] \\
& -\frac{\rho}{2}V^2F \cdot \bar{c} [C'_{m\delta}(\omega)\delta + C''_{m\delta}(\omega)/\omega \cdot \dot{\delta}] - M_{m\delta}\ddot{\delta} \\
& -qFs \left[\sum_j C'_{mqj}(\omega)q_j + C''_{mqj}(\omega)/\omega \cdot q_j \right] = 0 \quad [12]
\end{aligned}$$

Elastified Pitch Moment 'rigid' aircraft equation

$$\begin{aligned}
\sum M = & -\frac{\rho}{2}V^2F \cdot \bar{c}C_{m\alpha} + \alpha + I_y\dot{\omega}_y - \frac{\rho}{2}V^2F \cdot \bar{c}C''_{m\delta}(\alpha)\delta \\
& -\frac{\rho}{2}V^2F \cdot \bar{c}^2C_{mq}\omega_y - \frac{\rho}{2}V^2F \cdot \bar{c}^2C_{m\dot{\alpha}} \cdot \dot{\alpha} = 0 \quad [13]
\end{aligned}$$

- C' Real part of calc. aerodynamic coefficient
 C'' Imag. part of calc. aerodynamic coefficient
 $\frac{\rho}{2}V^2$ dynamic pressure
 F Reference area
 \bar{c}, s Reference length
 q_j generalized coordinate

It should be mentioned that at DASA structural dynamics in principle the same software for structural coupling and flutter is applied. Input datasets for both programs are common. Different solutions are used, because the flutter problem will be solved as a linear algebraic eigenvalue, whereas the structural coupling will be solved as a response problem with right hand side by inversion of the matrix. Therefore some general remarks for both solutions are summarized:

Structural Modeling

The assumptions to be made for dynamic modeling including hardware have to be conservative in order to cover any system failure.

Consideration of the full travel of the flexible mode frequencies with flight condition, fuel contents and actuator failure cases is necessary. The minimum experienced structural damping shall be applied. In order to be accurate, the analytical model has to be updated from ground resonance test results mainly with respect to mode frequencies.

In addition the aircraft identification test results from structural coupling test shall be adopted. Flexible mode frequency shifts with actuator demand amplitude shall be adopted to the modeling to represent minimum and maximum possible mode frequency.

The transfer function of the actuators shall meet the upper gain boundary. The actuator phase characteristic shall include both extremes for minimum and worst phase boundaries. Non-linear actuator characteristics with amplitude reduce structural coupling.

The actuator phase characteristic is important for the phase stabilization concept.

The transfer function of the sensor platform IMU (Inertial Measuring Unit) has to describe the upper gain boundary and the minimum and maximum phase boundary. Only the upper linear boundary is necessary to be represented.

Approximated measured flow sensor transfer functions shall be used.

Unsteady Aerodynamic Modeling

The unsteady forces used in the dynamic model calculation shall be represented in a conservative manner.

The magnitude (modulus) of the unsteady forces of the flexible modes and of the control surface deflection shall be predicted to represent a realistic high value for all Mach numbers and incidences. Since flow separation at higher incidences is leading to alleviation in the motion induced pressure distributions of the flexible modes and of the control surface deflections the introduction of unsteady aerodynamic forces from pure linear theory is regarded to be conservative. Special attention has to be put to transonic effects on the unsteady aerodynamic forces. Since, however, the structural coupling critical conditions which are related to the worst gain condition of the FCS are high incidence conditions, because the FCS gains result from low control surface efficiencies at high incidence, the assumption of linear unsteady subsonic and supersonic aerodynamics derived by linear theory or numerical Euler code calculations Ref ⁽¹⁰⁾ in the linear range is believed to be conservative throughout the full flight envelope.

The magnitude for the unsteady aerodynamic forces is sufficient for the design of high frequency elastic mode notch filters, because only a gain margin requirement is requested.

It shall be stated that the unsteady forces must be calculated for a number of reduced frequencies to cover the full frequency range.

For the phase stabilization of low frequency flexible modes like the first wing/fin bending the unsteady

aerodynamic phase shall be represented in a conservative manner. A reasonable approach for the phase of the first elastic mode is again the application of linear theory. The augmentation is that at high incidence and combined high FCS gains the aerodynamic damping is increased compared to low incidence from experience found for different wing configurations. In terms of phase stability margin Ref. (8) explains the difference in a Nichols diagram, where linear theory shows the more critical condition.

FCS Model

In order to design in a robust manner the calculation of open loop transfer functions shall consider the worst FCS gain conditions. The worst trimmed end to end gain conditions have to be included into the model calculations. Special consideration shall be also put to the maximum out of trim gain conditions with respect to structural coupling criticality.

4. Theoretical Modeling of the Structure

Figure 6 depicts the general layout of the EF2000. The aircraft was dynamically modeled by a 6 degree of freedom finite element model which fully representative of the total aircraft stiffness and mass.

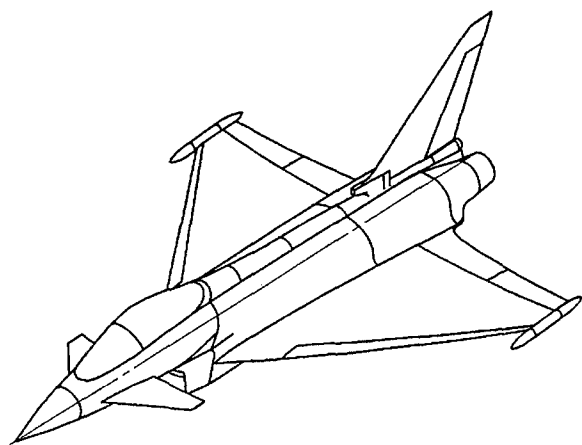

Figure 6: EF2000 General Layout

The clean aircraft was split up into different substructures, namely, foreplane, wing with flaps and slats, fuselage, fin and rudder. All substructures stiffness matrices were calculated with MSC NASTRAN, starting with a very fine static finite element model Figure 7 by applying a dynamic condensation to a coarse dynamic model, see Figure 8. For the fuselage generalized and equipment points were generated.

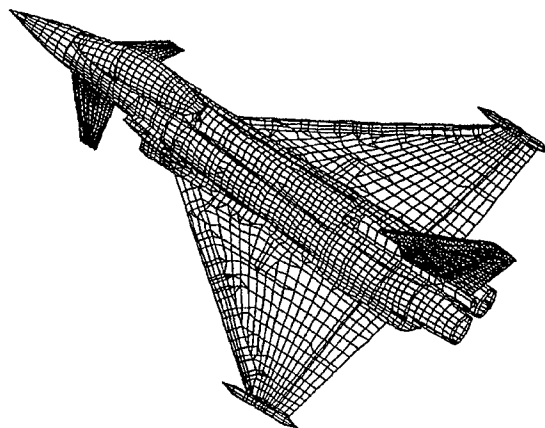

Figure 7: Finite Element Model Aircraft, static fine mesh

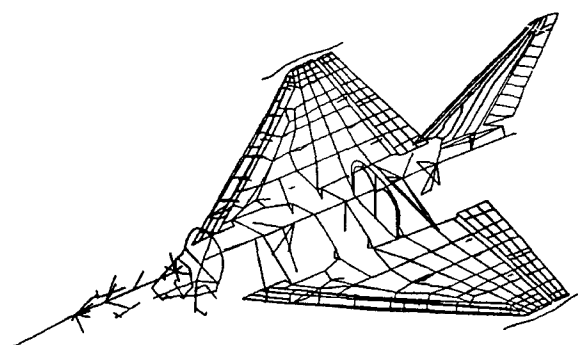

Figure 8: Finite Element Model Aircraft, dynamic coarse mesh

Definition of a fuselage Generalized Point

For each chosen fuselage section, a point was required, such that its motion would be representative of the section as a whole. Thus for a series of such points distributed along the length of the fuselage, the reduced stiffness and mass matrices could be obtained and hence the mode shapes and frequencies. The generalized point for the section was located at the center of gravity of the set of grid points to which it was connected. This generalized point was then connected, using an NASTRAN RBE3 element, to this set of points, each of which was a local hard point and had stiffness in X, Y and Z directions at least. The RBE3 element defines the motion as the weighted average of this set of points on the section. This method eliminates the local eigenmodes which are inside the fine grid system.

Fuselage Equipment points

Special grid points were created at the center of gravity of large items (greater than 30 kg) of non-structural mass, such as engines, undercarriage, gun, or avionics etc. where inertia loads were applied or

mass and inertia properties allocated. Each equipment point was connected back to the structure, using either elastic or rigid elements, in a manner representative of the actual installation.

Vibration normal modes of each substructure were produced and compared with and adjusted to available component tests.

In order to check the flutter mechanisms sensitivity to changes in structural stiffness and mass, actuator impedance etc. on investigated components and total aircraft using the branch mode model method. Using this method it is possible to identify flutter parameter which are sensitive to components (e.g. wing, foreplane) and control surfaces or store attachments.

The branch mode model is based on separate component stiffness and concentrated masses for the wing box, slats, flaps, fuselage, foreplane and fin and rudder. Basis for the calculation of the branch mode model is the NASTRAN component analysis. Additional coupling, junction and direct loads data are required to assemble the complete aircraft model. The coupling data for instants are actuator impedance, foreplane spigot bearing and back up stiffness, wing to fuselage attachment stiffness, fin to fuselage attachment stiffness, flap, slat, rudder attachment stiffness, pylon and pylon to wing attachment stiffness.

The branch mode method allow very easy the selection of symmetric and antisymmetric calculations.

The vibration modes of all substructures were used as branch modes and dynamically coupled together with rigid body modes to produce free-free total airplane vibration modes. Starting with 283 branch modes for the complete clean aircraft for the symmetric calculation 42 normal modes were used together with the rigid body modes for and aft, heave and pitch and rigid surface mode for inboard, outboard and foreplane rotation. For the antisymmetric calculation also 42 normal modes were used together with rigid body modes of side translation, roll and yaw and the surface rigid rotation of inboard, outboard and rudder.

Vibration Modes – modal analysis

As mentioned before for the flutter analysis the model was divided into a symmetric and antisymmetric dynamic half model. The fundamental normal modes at zero airspeed are described in Table 1.

Description of symmetric Modes	Frequency [Hz]
1st sym. wing bending	6.53
1st vertical fuselage bending	12.35
radome vertical mode	16.42
engine pitch symmetric	19.63
2nd sym. wing bending	20.33
tip pod pitch symmetric	21.54
1st wing torsion	23.88
engine lateral	25.04
chordwise wing bending sym.	29.97
1st sym. foreplane bending	32.80

Description of antisymmetric Modes	Frequency [Hz]
1st antisym. wing bending	7.27
1st fin bending	10.61
1st lateral fuselage bending	13.33
engine pitch antisymmetric	17.35
engine fore and aft	19.42
flap rotation	21.10
tip pod pitch antisymmetric	22.61
1st foreplane bending	23.42
1st wing torsion antisym.	26.81
foreplane bending	27.09

Table 1: Symmetric and Antisymmetric Mode Shapes of the clean Aircraft.

This modeshapes were use for calculating the unsteady aerodynamic forces for flutter analysis.

5. Flutter Calculations

The flutter calculations are produced using a modified in-house p-k method. The results are performed for different mission configurations, Mach number, altitudes and the corresponding flight control laws, by interpolation of frequency, flutter speed and unsteady aerodynamics. No interpolation was made between the investigated Mach number and the flight control data, because the change in flutter speed should be shown as functions of different gains. 2.5% structural damping (g) was introduced into the calculation.

In general, we have to look for three flutter modes:

- wing bending mode on antisymmetric / symmetric calculation. The flutter onset is very high and above the flight envelope at sub and supersonic speed
- foreplane torsion in the symmetric flutter calculation
- flap mode in the antisymmetric calculation

Figures 11-14 depicts v-g plots for sub and supersonic analysis for longitudinal investigation. The flutter onset is nearly unchanged for the wing bending mode at subsonic speed. Whereas the flutter point of the foreplane mode decreases about 50 Kts in closed loop at supersonic analysis. At high α ($\alpha=15'$ or $-3'$) an additional decrease of about 50 kts were calculated showing the same flutter behaviour. Some practical remarks about the flutter calculation including FCS. The analysis is divided into an open loop and a closed loop analysis. Zero speed eigenfrequencies were used as a starting point for the closed loop analysis because the calculation should show the influence of FCS on elastic modes. Later, all modes (elastic and system) were calculated to understand more the behaviour of the elastic modes. In the longitudinal analysis the notch filters were phase stabilized which includes some active control parts into the elastic system area. The result of phase stabilization is an increase of damping for the wing bending mode at unchanged flutter point. The antisymmetric calculations are not shown in this paper, because the flutter mechanism and the flutter point is almost the same with and without FCS.

6. Flight Flutter Testing

For flutter it is necessary to provide evidence of qualification or verification of fitness of purpose to ensure safe flight, adequacy for the flight test task and verification against the specification.

Flight flutter test were performed applying a FBI (Frequency Bias Injection) signal input by the flight test group of British Aircraft Corporation. First data evaluations show that differences in frequency and damping of the conditions are within the measuring accuracy, Ref. 3.

7. Conclusion

This paper describes briefly the flutter experience gained on a modern fighter project including the Flight Control System. The theoretical work which describes the expansion of the dynamic equation with the control equation of the classical flutter solution is shown. The following points should be highlighted:

- It is absolutely necessary to have a reliable dynamic model of the elastic aircraft which must be verified by ground vibration tests.

- Ground tests to check structural mode coupling interaction must be performed to assure stability and to compare with analytical predictions. If correlation is achieved variation of parameters such as external stores, fuel content can be investigated pure analytically
- Open and closed loop flutter calculations have to be done to cover the full flight envelope. Calculations have shown negligible influence of FCS on flutter at lg flight, but an decrease of flutter onset at high a conditions.
- Using phase stabilized notch filter, the damping of the first wing bending mode increases substantially by nearly unchanged flutter point.

8. References

- [1] Lotze A., Sensburg O., and Kühn M. Flutter Investigations on a Combat Aircraft with a Command and Stability Augmentation System AIAA Paper No. 75-1025, AIAA 1975 Aircraft Systems and Technology Meeting, Los Angeles
- [2] Becker J., Luber W. Flight Control Design Optimization with Respect to Flight and Structural Dynamics Requirements AIAA 96-4047, 6th AIAA/NASA Symposium on Multidisciplinary Analysis and Optimization, MDO Bellevue, WA, USA, Sept. 1996
- [3] Ramsay R. B. Flight Flutter Testing of Combat Aircraft AGARD Structure and Material Panel Meeting, Rotterdam, The Netherlands, 8-10 May 1995, AGARD CP-566
- [4] Luber W. Flutter Investigation of a Fighter Aircraft Including Flight Control System International Forum on Aeroelastic and Structural Dynamics, Rome, Italy June 1997
- [5] Ramsay R. B. Flutter Certification and Qualification of Combat Aircraft International Forum on Aeroelastic and Structural Dynamics, Manchester, UK, June 1995
- [6] Ramsay R. B. In-Flight Structural Mode Excitation System for Flutter Testing AGARD Conference Proceedings 519 Chania, Crete, Greece, 11th-14th May 1992

- [7] Vaccaro V., Becker J.
Ground Structural Coupling Testing and Model Updating in the Aeroservoelastic Qualification of a Combat Aircraft.
AGARD, Meeting on Advanced Aeroservoelastic Testing and Data Analysis,
Rotterdam, The Netherlands, 8-10 May 1995.
- [8] Becker J., Luber W.
Unsteady Aerodynamic Forces at High Incidence and their Application in Structural- and Flight Control Design.
International Forum on Aeroelasticity and Structural Dynamics; Manchester, UK; 26-28 June 1995
- [9] Becker J., Vaccaro V.
Aeroservoelastic Design, Test Verification and Clearance of an Advanced Flight Control System.
AGARD Meeting on Advanced Aeroservoelastic Testing and Data Analysis,
Rotterdam, The Netherlands, 8-10 May 1995
- [10] Hönlinger H., Zimmermann H.,
Sensburg O., Becker J.
Structural Aspects of Active Control Technology
AGARD Conference Proceedings on Active Control Technology, FMP Symposium held at Turin, Italy, May 1994
- [11] Caldwell B.D.
The FCS-Structural Coupling Problem and its Solution.
AGARD Conference Proceedings on Active Control Technology, FMP Symposium held at Turin, Italy, May 1994
- [12] Heller G., Kreiselmeier E.
Eulerluftkräfte für Klappenschwingungen
TUM-FLM-96/05; Lehrstuhl für Fluidmechanik, Technische Universität München
- [13] Bennekens B.
Description of the computer programs for the calculation of aerodynamic loads on oscillating wing-body configuration in subsonic flow (NLRI-Method)
NLR-TR-76120 C
- [14] Roos F., Bennekens B., Zwaan T.
Calculation on unsteady subsonic flow about harmonically oscillating wing/ body configurations
Journal of Aircraft Vol. 14. No. 5. May 1977
- [15] Becker J., Weiss F., Sensburg O.
Compatibility of active control technologies with aircraft structure design.
International Symposium on Structural Control University of Waterloo/Ontario (Canada), July 1985
- [16] Försching H.
Introductory survey of aeroelastic problems in separated and transonic flow
Von Karman Institute for Fluid Dynamics Lecture Series 1981-4

D:\FLOWD3E.AF3

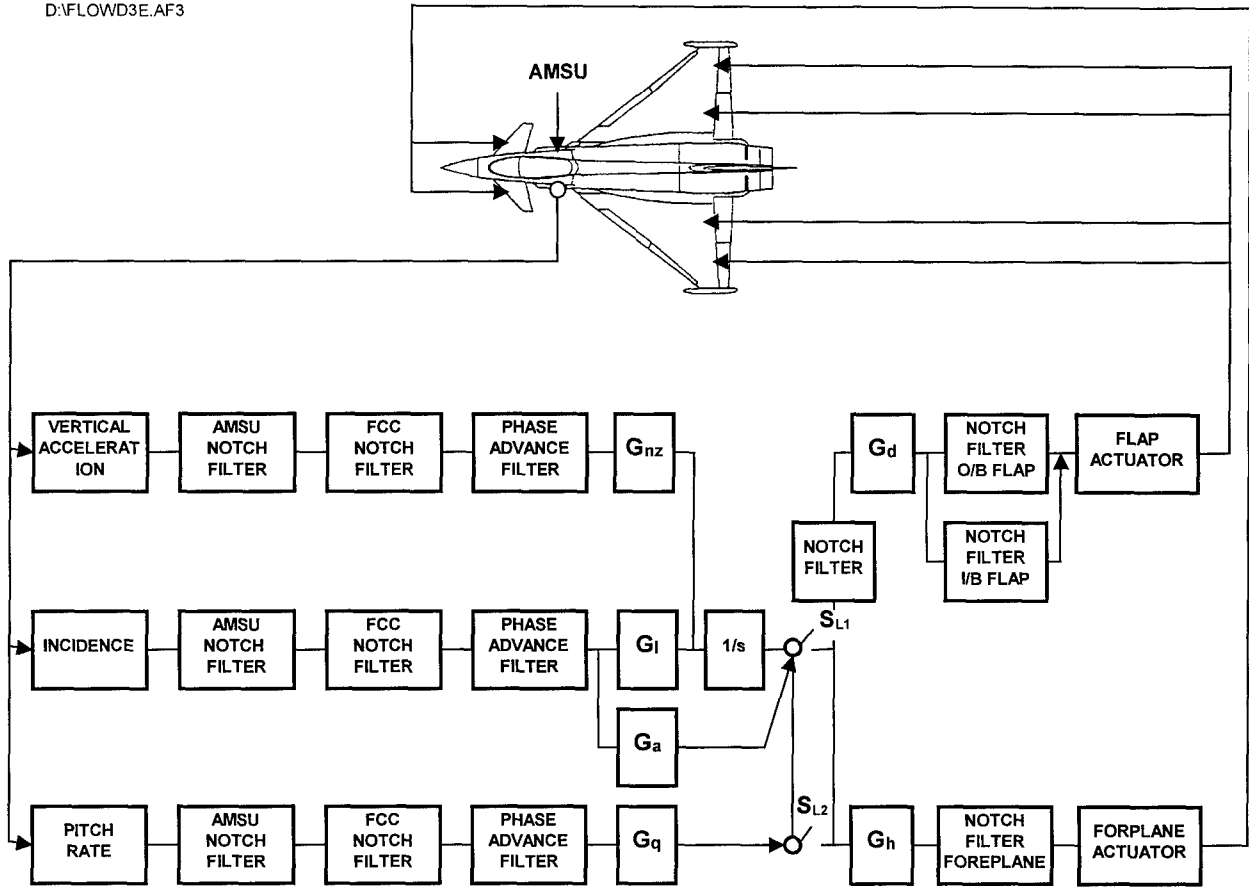

Figure 9: Flow chart of longitudinal control

D:\FLOWD2.AF3

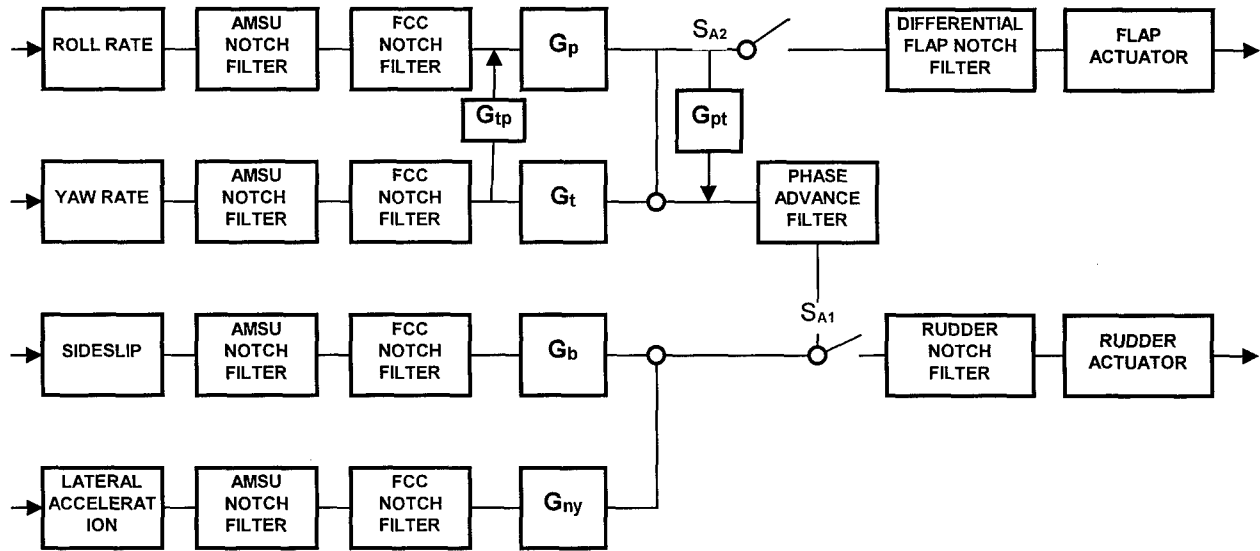

Figure 10: Flow chart of lateral control

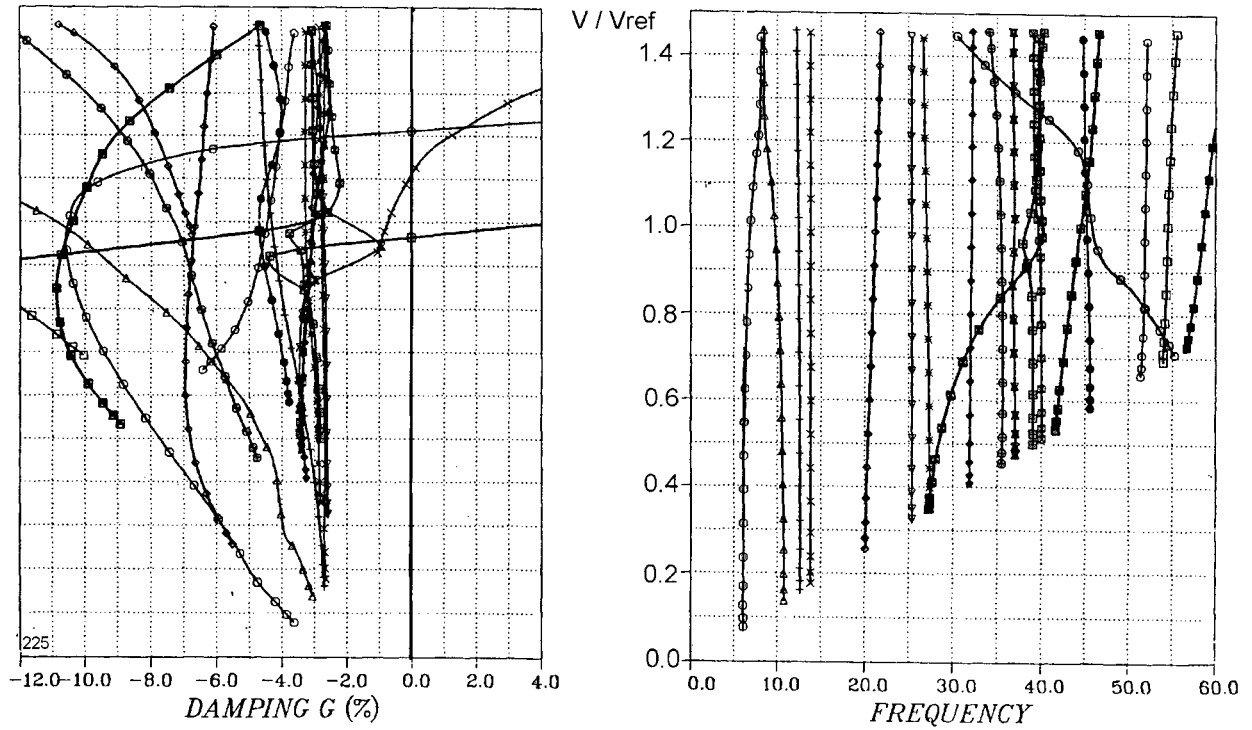

Figure 11: Damping and Frequency versus Flutterspeed, Mach=0.9, Symmetric, sea level, open loop

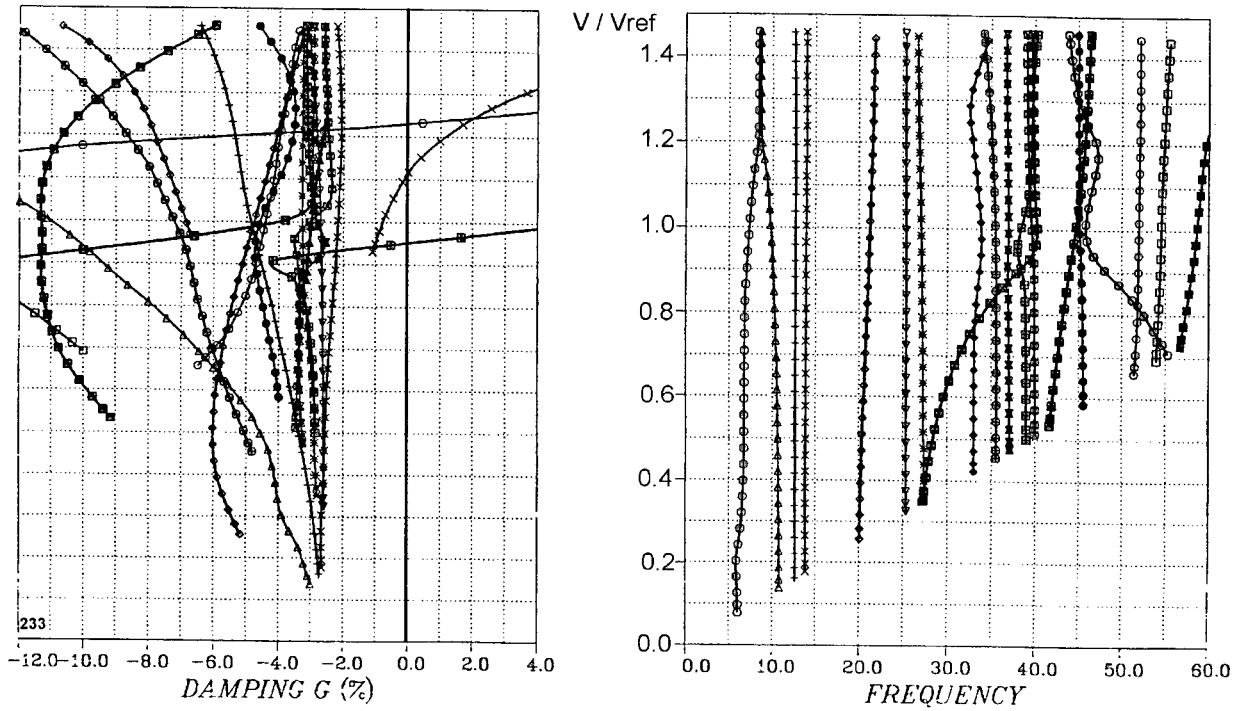

Figure 12: : Damping and Frequency versus Flutterspeed, Mach=0.9, Symmetric, sea level, closed loop

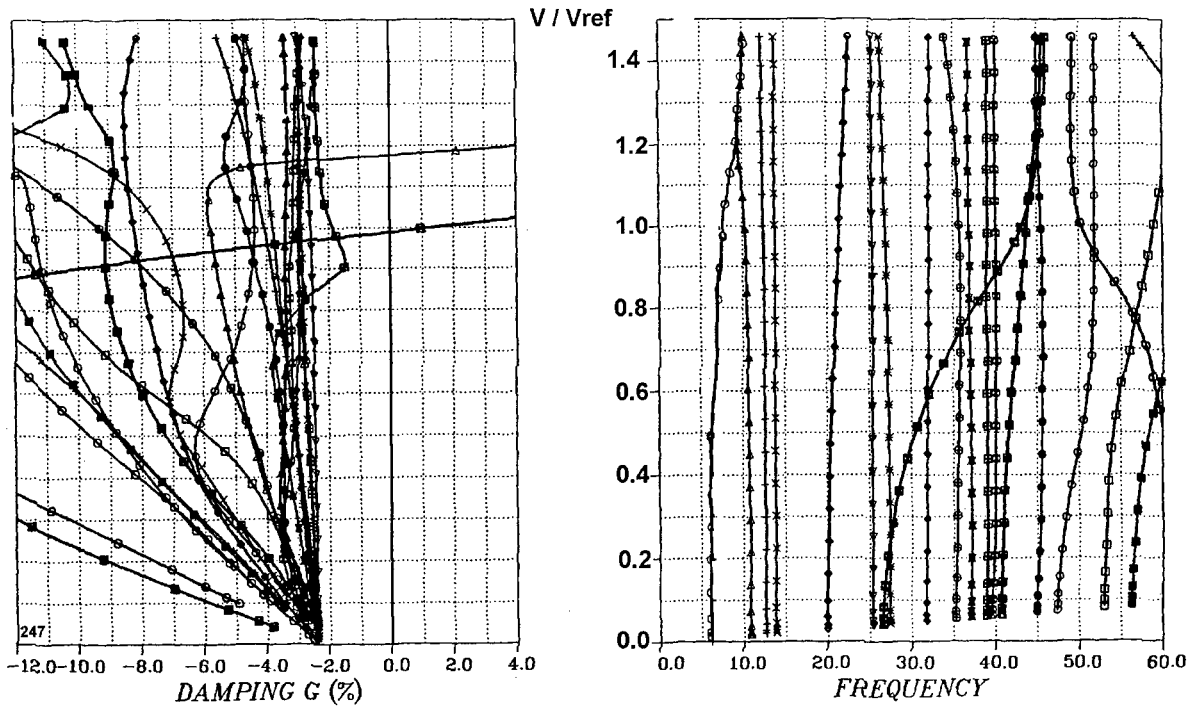

Figure 13: : Damping and Frequency versus Flutterspeed, Mach=1.2, Symmetric, sea level, open loop

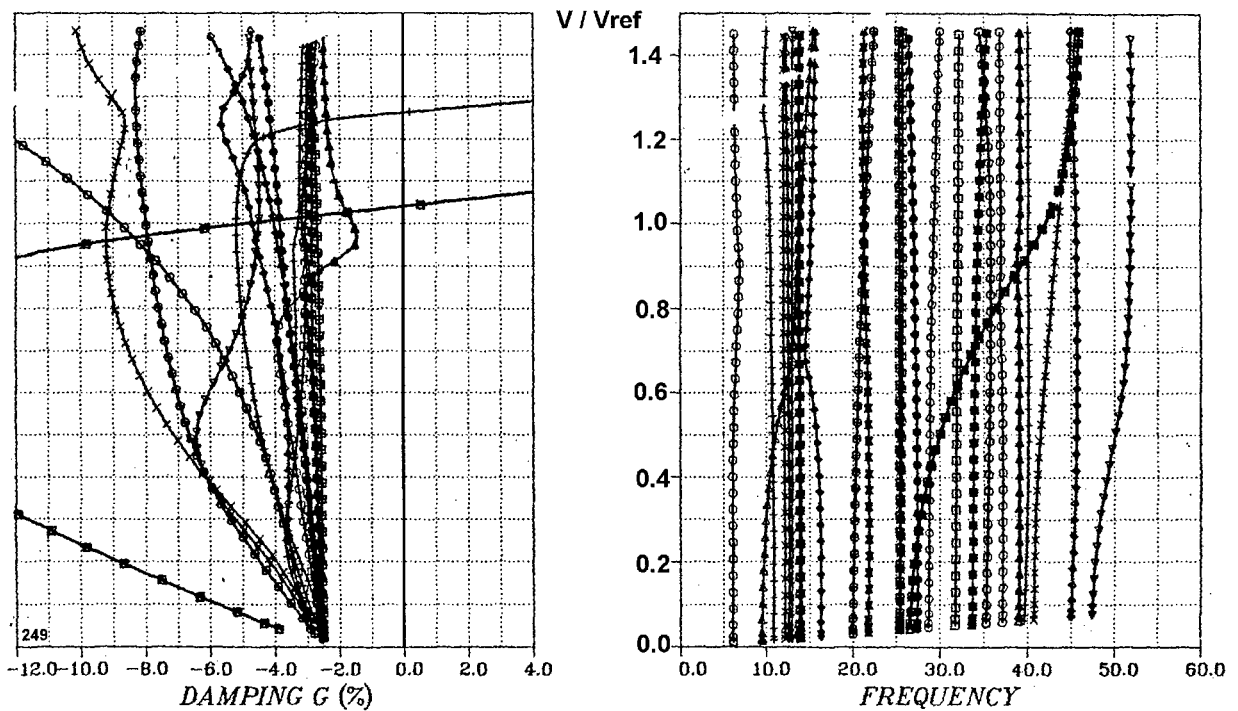

Figure 14: : Damping and Frequency versus Flutterspeed, Mach=1.2, Symmetric, sea level, closed loop