

UNCLASSIFIED

Defense Technical Information Center
Compilation Part Notice

ADP014990

TITLE: Radiofrequency Glow Discharges Used for Optical Emission Spectroscopy: An Experimental and Analytical Approach

DISTRIBUTION: Approved for public release, distribution unlimited

This paper is part of the following report:

TITLE: International Conference on Phenomena in Ionized Gases [26th]
Held in Greifswald, Germany on 15-20 July 2003. Proceedings, Volume 4

To order the complete compilation report, use: ADA421147

The component part is provided here to allow users access to individually authored sections of proceedings, annals, symposia, etc. However, the component should be considered within the context of the overall compilation report and not as a stand-alone technical report.

The following component part numbers comprise the compilation report:

ADP014936 thru ADP015049

UNCLASSIFIED

Radiofrequency glow discharges used for optical emission spectroscopy : an experimental and analytical approach

L. Therese, Ph. Guillot, and Ph. Belenguer

Centre de Physique des Plasmas et Applications de Toulouse,
Université Paul Sabatier, 118 route de Narbonne, 31062 Toulouse Cedex, France

1. Introduction

Glow discharge optical emission spectroscopy (GD-OES) is an analytical technique widely used for elemental and depth profiling analysis of materials [1]. The technique is based on the analysis of the optical emission of atoms sputtered from the cathode and excited in the plasma. Radio frequency excitation of the glow discharge (RF-GD-OES) is developed for quantitative analysis of non-conductive samples.

Capacitively coupled radio frequency discharges have been extensively studied both experimentally and theoretically over the past decade in the context of plasma processing for the microelectronics industry and thus these discharges are fairly well understood [2-3].

The operating conditions used in RF-GDOES are, however, different than those standardly used in plasma processing, leading to a discharge behavior quite unusual and it is our aim to understand this behavior.

2. Experimental set-up

The experimental set-up is based on the industrial Jobin Yvon Horiba RF-5000 instrument on which the optical components have been removed, as material analysis is not considered here. The source used is a 4 mm diameter cylindrical copper electrode facing a plane electrode. The plane electrode is the sample itself and the gap space between the two electrodes is maintained by a toroidal joint. The 13.56 MHz radiofrequency voltage is applied on the back of the sample with a cylindrical applicator through a blocking capacitor. A matching box insures the coupling between the generator and the source. A Pirani gauge is used to monitor the pressure inside the reactor.

One problem of major concern in measuring the discharge current in radiofrequency discharges is removing the capacitive current due to the reactor capacitance. Applying a radiofrequency voltage of the form $V = V_{rf} \cos(\omega t)$, to the back of the sample, give rise to a capacitive current ($C_s dV/dt$), where C_s is the system capacitance. This current is much higher than the total discharge current. The method for suppressing this capacitive current in the GD-OES instrument is based on the technique perfected on the GEC (Gaseous Electronics Conference) reference cell. More detailed information can be found in reference [4]. Similar measurements for lower frequency discharges have been performed by Hoffmann' group using a different technique [5].

A diagram of the plasma reactor and electrical measurement system is shown figure 1. The two current probes used are Solar 9323-1 of Rogowski type. The windings of the probes are essentially the secondary windings of a toroidal transformer. The RF cable, carrying the current to be measured, acts as the primary winding of the transformer. The voltage probe is a Tektronix P5100, 100x. A high performance oscilloscope, Tektronix TDS 7104 is used. The vacuum variable capacitor is a Jennings C/GCS -100-15 picofarads.

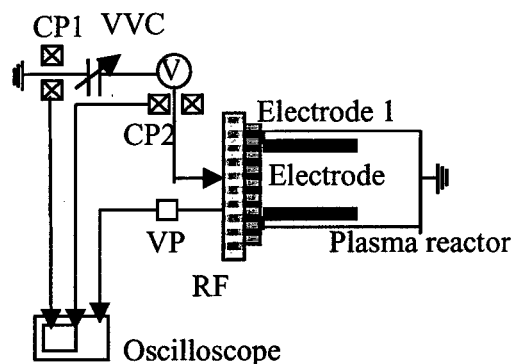

Figure 1: Schematic diagram of the electrical measurement technique. CP1 and CP2, Current Probes, VVC, Vacuum Variable Capacitor, VP, Voltage Probe.

3. Results

In this section, we will study the results obtained for a radiofrequency discharge in argon at 950 Pascal, 13.56 MHz and for a titanium sample at 10 watts. In the first part of this chapter we will show the experimental measurements of the current and voltage, in the second part we will analyze the results with the help of an analytical approach.

Figure 2 shows the current and voltage measured on the two lines (reactor and variable capacitor) for a radiofrequency cycle. We can see on this figure that the measured currents are capacitive currents; the phase shift between the currents and the voltage is close to 90 degrees. We notice that the two currents are very similar, therefore the total discharge current will be only a small part of the total current. The amplitude of the total current is about 1.2 A. The current on the two electrodes has to be identical over a radiofrequency cycle. The surface of the two electrodes being different,

the voltage exhibits a large bias, the voltage is shifted to negative values. The voltage and the current are measured on the back of the sample, the small electrode. The measured voltage is of the form $V(t) = V_{rf} \cos(\omega t) + V_{bias}$, under our conditions we find $V_{rf} = -350$ V, $V_{bias} = -260$ V. That means that the sample is a cathode for most of the cycle. It is during the cathodic part of the cycle when the voltage is negative on the sample that the electrode is sputtered.

On figure 3, we present the total discharge current obtained by subtracting the 2 previous measured currents. The maximum amplitude is about 0.25 A, at half cycle.

The discharge current is the sum of three terms corresponding to the electron, ion and displacement current. It is possible to extract the displacement current from the measured total current if we assume that the electric field contracts and expands in a similar way.

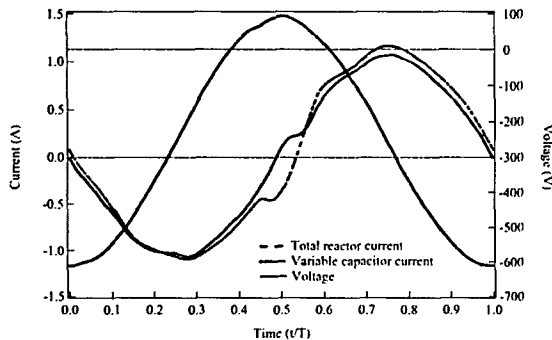

Figure 2 : Voltage and current time variations over a radiofrequency cycle. Titanium, 950 Pa, 13.56 MHz, 10 Watts.

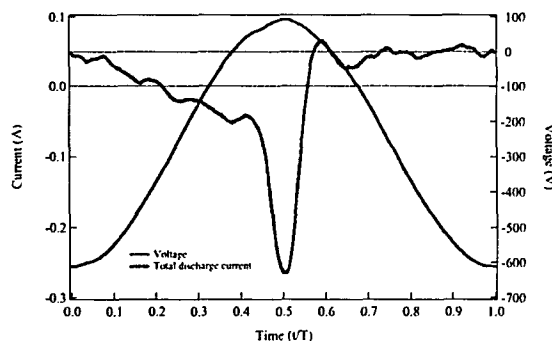

Figure 3 : Voltage and total discharge current time variations over a radiofrequency cycle.

4. Analytical Considerations

To calculate analytically the displacement current, we need to make an assumption on the temporal variation of the electric field on the electrode. We assume a linear decrease of the electric field in the sheath and a parallel slope decrease and increase of the sheath. The last assumption is to consider that all the applied potential is

completely distributed in the sheath; there is no positive column.

The applied potential $V(t) = V_{rf} \cos(\omega t) + V_{bias}$. At time $t=0$, $V = V_{rf} + V_{bias}$

If all the potential is distributed in the sheath we have $E_0 = -2(V_{rf} + V_{bias})/d_0$, E_0 being the electric field on the electrode and d_0 the sheath length at time $t=0$. E_0 and d_0 are the maximal values of $E(t)$ and $d(t)$ as the applied potential is maximal at $t=0$. As we have a constant slope at any time we have $E(t)/E_0 = d(t)/d_0$. We can easily get the following relation:

$$E(t) = E_0 \left(\frac{V(t)}{V_{rf} + V_b} \right)^{0.5}$$

We can calculate the displacement current:

$$I_d = S \epsilon_0 \frac{dE}{dt} \quad \text{where } S \text{ is the sample surface}$$

The best agreement between the calculation and the experimentally deduced displacement current is obtained for $E_0 = 65 \text{ kV cm}^{-1}$. Knowing E_0 , and the displacement current it is possible to have access to important information on the discharge characteristics, we will present here these results.

5. Conclusion

We measured the total current and the voltage time variations for a radiofrequency discharge using a titanium sample at 13.56 MHz, 950 Pa and 10 watts in argon. From these measurements, we were able to electrically characterize the discharge and to get information on the plasma. We found that the plasma is only extended a few millimeters from the sample surface, 2.6 mm, and has a rather high density.

Acknowledgements: The authors would like to thank L.C. Pitchford, J.P. Boeuf, G. Gozadinos, P. Chapon, and R. Payling for stimulating discussions on radiofrequency discharges. This work has been supported by Jobin Yvon Horiba Group, France.

6. References

- [1] *Glow Discharge Optical Emission Spectroscopy*, eds. Payling R., Jones D. and Bengston A., John Wiley Sons, New York, 1997.
- [2] *Nonequilibrium Processes in Partially Ionized Gases*, eds. Capitelli M. and Bardsley J. N., Plenum Press, New York, 1990; 220: 155.
- [3] *Modeling Collisional Low-Temperature Plasmas*, Special Issue, IEEE Trans. Plasma Sci, 1991; 2. Press, London, 1998.
- [4] Hargis P. J. *et al.*, Rev. Sci. Instrum., 1994; 65: 140.
- [5] Bogaerts A., Wilken L., Hoffmann V., Gijbels. and, Wetzig K., Spectrochimica acta: part B, 2001; 56: 551.